

[The page contains extremely faint, illegible text, likely bleed-through from the reverse side of the document. The text is arranged in vertical columns and is too light to transcribe accurately.]

LIBRARY OF CONGRESS.

Chap. *AE5* Copyright No.

Shelf *N56*

UNITED STATES OF AMERICA.



SECOND COPY,
1899.

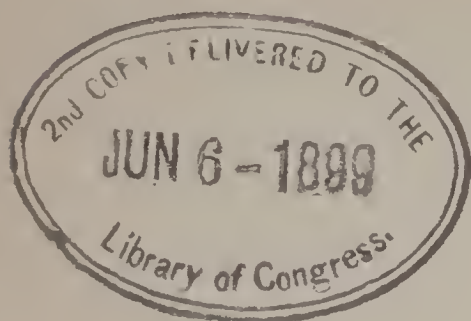

SECOND COPY,
1899.

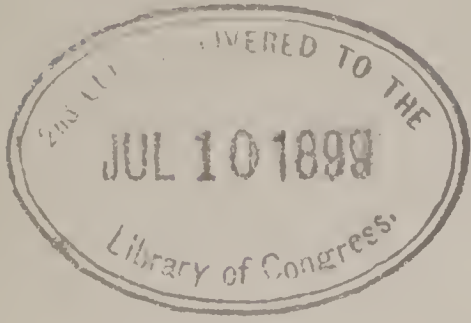

FEB 27 1899

THE NEW
NATIONAL CYCLOPÆDIA

THE NEW
NATIONAL CYCLOPÆDIA
AND TREASURY OF KNOWLEDGE.

A HANDY BOOK OF READY REFERENCE FOR SCHOOLS.

THE ARTICLES RELATING TO AMERICA EDITED BY

AINSWORTH R. SPOFFORD, LATE LIBRARIAN OF CONGRESS,

AND EDITOR OF THE "LIBRARY OF CHOICE LITERATURE."

THE ARTICLES RELATING TO EUROPE EDITED BY

CHARLES ANNANDALE, M.A., LL.D.,

EDITOR OF THE "IMPERIAL DICTIONARY," ETC.

—THE WORK COMPRISES—

A CYCLOPÆDIA OF GENERAL KNOWLEDGE.

A DICTIONARY OF HISTORICAL EVENTS.

A COMPLETE ATLAS OF AUTHORIZED MAPS.

A LIBRARY OF BIOGRAPHY.

A GAZETTEER OF THE WORLD.

Vol. III.

TOLEDO, OHIO :

THE BROWN, EAGER AND HULL CO.

1899.

L

AE3-
N56

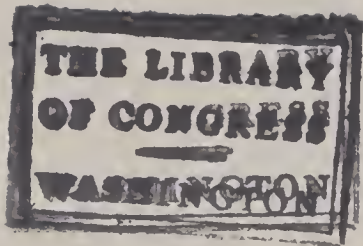

35666

COPYRIGHT, 1899, BY
THE GEBBIE PUBLISHING CO., Limited.

TWO COPIES RECEIVED.

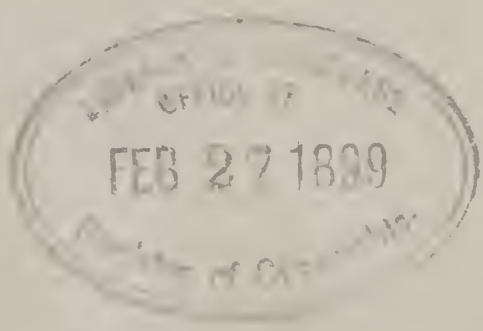

15150 *
Feb. 25. 99.

7.

KEY TO THE PRONUNCIATION.

The pronunciation of the words that form the titles of the articles is indicated in two ways: 1st, By *re-writing* the word in a different form and according to a simple system of transliteration. 2d, By marking the syllable on which the chief *accent* falls. Entries which simply have their accentuation marked are English or foreign words that present little difficulty, and in regard to which readers can hardly go far wrong. A great many of the entries, however, cannot be treated in this way, but must have their pronunciation represented by a uniform series of symbols, so that it shall be unmistakable. In doing this the same letter or combination of letters is made use of to represent the same *sound*, no matter by what letter or letters the sound may be represented in the word whose pronunciation is shown. The key to the pronunciation by this means is greatly simplified, the reader having only to remember one character for each sound. Sounds and letters, it may be remarked, are often very different things. In the English language there are over forty sounds, while in the English alphabet there are only twenty-six letters to represent them. Our alphabet is, therefore, very far from being adequate to the duties required of it, and still more inadequate to represent the various sounds of foreign languages.

The most typical *vowel* sounds (including diphthongs) are as shown in the following list, which gives also the characters that are used in the Cyclopaedia to show their pronunciation, most of these being distinguished by diaeritical marks.

<p>ā, as in <i>fate</i>, or in <i>bare</i>.</p> <p>ä, as in <i>alms</i>, Fr. <i>âme</i>, Ger. <i>Bahn</i>=á of Indian names.</p> <p>â, the same sound short or medium, as in Fr. <i>bal</i>, Ger. <i>Mann</i>.</p> <p>a, as in <i>fat</i>.</p> <p>â, as in <i>fall</i>.</p> <p>ɑ, obscure, as in <i>rural</i>, similar to <i>u</i> in <i>but</i>, é in <i>her</i>: common in Indian names.</p> <p>ē, as in <i>me</i>=<i>i</i> in <i>machine</i>.</p> <p>e, as in <i>met</i>.</p> <p>ê, as in <i>her</i>.</p> <p>ī, as in <i>pine</i>, or as <i>ei</i> in Ger. <i>mein</i>.</p> <p>i, as in <i>pin</i>, also used for the short sound corresponding to ē, as in French and Italian words.</p>	<p>eu, a long sound as in Fr. <i>jeune</i>, = Ger. long ö, as in <i>Söhne</i>, <i>Goethe</i> (Goethe).</p> <p>eu, corresponding sound short or medium, as in Fr. <i>peu</i>=Ger. ö short.</p> <p>ō, as in <i>note</i>, <i>moan</i>.</p> <p>o, as in <i>not</i>, soft—that is. short or medium.</p> <p>ö, as in <i>move</i>, <i>two</i>.</p> <p>ū, as in <i>tube</i>.</p> <p>u, as in <i>tub</i>: similar to é and also to a.</p> <p>u, as in <i>bull</i>.</p> <p>ü, as in Sc. <i>abune</i>=Fr. <i>û</i> as in <i>dû</i>, Ger. <i>ü</i> long as in <i>grün</i>, <i>Bühne</i>.</p> <p>û, the corresponding short or medium sound, as in Fr. <i>but</i>, Ger. <i>Müller</i>.</p> <p>oi, as in <i>oil</i>.</p> <p>ou, as in <i>pound</i>; or as <i>au</i> in Ger. <i>Haus</i>.</p>
--	--

Of the *consonants*, b, d, f, h, j, k, l, m, n, ng, p, sh, t, v, z, always have their common English sounds, when used to transliterate foreign words. The letter e is not used by itself in re-writing for pronunciation, s or k being respectively used instead. The only consonantal symbols, therefore, that require explanation are the following:—

<p>ch is always as in <i>rich</i>.</p> <p>d, nearly as <i>th</i> in <i>this</i>=Sp. <i>d</i> in <i>Madrid</i>, &c.</p> <p>g is always hard, as in <i>go</i>.</p> <p>h represents the guttural in Scotch <i>loch</i>, Ger. <i>nach</i>, also other similar gutturals.</p> <p>ñ, Fr. nasal <i>n</i> as in <i>bon</i>.</p> <p>r represents both English <i>r</i>, and <i>r</i> in foreign words, which is generally much more strongly trilled.</p>	<p>s, always as in <i>so</i>.</p> <p>th, as <i>th</i> in <i>thin</i>.</p> <p>th, as <i>th</i> in <i>this</i>.</p> <p>w always consonantal, as in <i>we</i>.</p> <p>x=ks, which are used instead.</p> <p>y always consonantal, as in <i>yea</i> (Fr. <i>ligne</i> would be re-written <i>lëny</i>).</p> <p>zh, as <i>s</i> in <i>pleasure</i>=Fr. <i>j</i>.</p>
--	--

THE NEW CABINET CYCLOPÆDIA

VOL. III.

Cone, as used in geometry, generally means a right circular cone, which may be defined as the solid figure traced out when a right-angled triangle is made to revolve round one of the sides that contain the right angle. A more comprehensive definition may be given as follows:—Let a straight line be held fixed at one point, and let any other point of the line be made to describe any closed curve which does not cut itself; the solid figure traced out is a cone. When the curve which the second point describes is a circle, the cone is a right circular cone. The cubical content of a right circular cone is one-third of that of a cylinder on the same base and of the same altitude, and is therefore found by multiplying the area of the base by the altitude, and taking one-third of the product. See also *Conic Sections*.

Cone, in botany, a dry compound fruit, consisting of many open scales, each with two seeds at the base, as in the conifers; a strobilus.

Conegliano (ko-nel-yä'nō), a town, Italy, province of Treviso, 28 miles north of Venice. It has a castle and cathedral with paintings by Cima da Conegliano. Manufactures: silk and woollen cloths. Pop. 5191.

Cone-shell. See *Conus*.

Conessi-bark, the bark of *Wrightia antidysenterica*, an apocynaceous plant of India, used as a tonic, a febrifuge, and an astringent in diarrhœa.

Coney Island, a small island 9 m. south-east of New York, at the west end of Long Island, a favourite summer bathing resort, having a fine beach, splendid hotels, and numerous other attractions and accommodations for visitors.

Confederate States, the name given to eleven of the Southern States of America, which attempted to secede from the Union on the election of Abraham Lincoln, the Republican candidate, to the presidency in

November, 1860, thus leading to the great civil war which lasted till 1865. See *United States*.

Confederation, GERMANIC. See *Germany*.

Confederation of the Rhine, the league of Germanic states formed by Napoleon Bonaparte in 1806, and including Bavaria, Wurtemberg, Baden, Hesse-Darmstadt, the Kingdom of Westphalia, &c. It extended over 125,160 sq. miles, and comprised 14,608,877 inhabitants. The princes undertook to raise collectively a large body of troops in event of war, and established a diet at Frankfort; but the failure of Napoleon's Russian campaign of 1812 shook the structure, and the league soon after broke up. It was succeeded by a new league, the Germanic Confederation.

Conference, (1) a meeting of the representatives of different foreign countries for the discussion of some question. (2) A meeting between delegates of the two houses of parliament called to discuss the provisions of a bill with regard to which they are disagreed, with the object of effecting an agreement between them. (3) The annual meetings of Methodist Episcopal Church for deliberation on its affairs.

Conferva'ceæ, a family of marine or fresh-water algæ having green fronds which are composed of articulated filaments simple or branched. The cells are shortish and cylindrical, and they are reproduced not by conjugation, but by zoospores formed from the cell-contents and furnished with two or four cilia. The typical genus *Conferva* is found, either attached to various bodies or floating, swollen up with bubbles



Conferva (*Cladophora nuda*). a, branched filament magnified.

of gas in dense masses on ponds. The well-known marine delicacy, laver (*Porphyra laciniata* and *P. vulgaris*), with the green laver (*Ulva latissima*), belongs to this tribe of plants.

Confession, a term sometimes applied to a profession of faith; for instance, the Confession of Augsburg. It sometimes also signifies a religious sect; as the three Christian confessions—the Roman Catholic, the Lutheran, and the Calvinistic. *Confiteor* (I acknowledge) is the confession which the Catholic priests make before the altar when beginning mass or public worship.

Confession, **AURICULAR**, in the strictest sense, the disclosure of sins to the priest at the confessional, with a view to obtain absolution for them. The person confessing is allowed to conceal no sin of consequence which he remembers to have committed, and the father confessor is bound to perpetual secrecy. The practice of a public acknowledgment of great sins was altered by Pope Leo the Great, in 450, into a secret one before the priest, and the fourth general Lateran council (1215) ordained that every one of the faithful, of both sexes, come to years of discretion, should privately confess all their sins at least once a year to their own pastor, an ordination still binding on members of the R. Catholic Church. Confession is a part of the sacrament of penance.

Confessional, in Roman Catholic churches and chapels, a kind of inclosed seat in which



Confessional, Cathedral of St. Gudule, Brussels.

the priest sits to hear persons confess their sins. The confessional is often not unlike a sentry-box, the priest sitting within and the penitent kneeling without and speaking through an aperture. Many confessionals

are in three divisions or compartments, the centre, which is for the reception of the priest, being closed half-way up by a dwarf door, and having a seat within it. The side compartments, which communicate with the centre by grated apertures, are for the penitents.

Confession of Augsburg. See *Augsburg Confession*.

Confession of Faith, a statement of religious beliefs, a kind of elaborate creed. (See *Creed*.) What is most distinctively known by this name is the document prepared by the Assembly of Divines which met at Westminster in obedience to an ordinance of parliament issued June 12, 1643. The whole number of the assembly amounted to 174 members, mostly Puritans, thirty-two being members of parliament. There were also six Scottish commissioners appointed to consult and deliberate, but not to vote. One of the chief results of the deliberations was the framing of the Confession of Faith, which, on the return of the Scottish commissioners, was adopted by the Assembly of the Church of Scotland, August 27, 1647.

Confidential Communication, in law, a communication made by one person to another which the latter cannot be compelled to give in evidence as a witness. Generally all communications made between a client and his agent, between the agent and the counsel in a suit, or between the several parties to a suit, are treated as confidential. The privilege of confidentiality does not extend to disclosures made to a medical adviser, and in England it has been decided also that confessions made to a priest are not to be treated as confidential.

Confirma'tion, the ceremony of laying on of hands by a bishop in the admission of baptized persons to the enjoyment of Christian privileges, the person confirmed then taking upon himself the baptismal vows made in his name. It is practised in the Greek, Roman Catholic, Lutheran, and English churches. In the Roman Catholic churches a delay of 7 years is interposed after baptism, in the Lutheran from 13 to 16, and in the English Church from 14 to 18, though in the latter there is no fixed period. The Lord's supper is not taken by these sects until after confirmation.

Confisca'tion, the act of condemning as forfeited, and adjudging to the public treasury, the goods of a criminal in part punishment of a crime.

Confor'mable, in geol., lying in parallel or nearly parallel planes, and having the same dip and changes of dip; said of strata, the opposite term being *unconformable*.

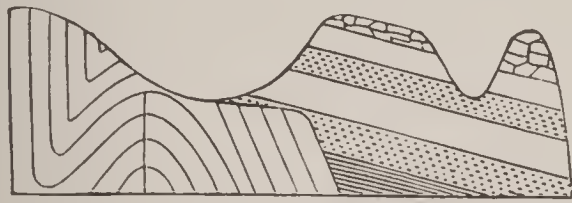

Conformable Strata *a* and *b*, Unconformable at *c*.

Confu'cius, or KONG-FU-TSE, that is, 'the teacher, Kong,' the famous Chinese sage, born about 550 B.C. in the province of Shantung, then belonging in part to the small vassal kingdom of Lu. His father, Shuh-liang-heih, who was of royal descent, died three years later, and the boy was reared in comparative poverty by his mother, Ching-tsai. At the age of seventeen he was made inspector of corn-markets, at nineteen he married, and after about four years of domesticity, in which a son and two daughters were born him, he commenced his career as a teacher. In 517 B.C. he was induced by two members of one of the principal houses in Lu, who had joined his band of disciples, to visit the capital with them, where he had interviews with Lao-tze, the founder of Taouism. Though temporarily driven from Lu to Tsi by a revolution, he soon returned thither with an increasing following, and at the age of fifty-two was made chief magistrate of the city of Chung-too. So striking a reformation was effected by him that he was chosen for higher posts, became minister of crime, and with the aid of two powerful disciples elevated the state of Lu to a leading position in the kingdom. Its marquis, however, soon after gave himself up to debauchery, and Confucius became a wanderer in many states for thirteen years. In 483 he returned to Lu, but would not take office. The deaths of his favourite disciples Yen Hwin and Tze-lu in 481 and 478 did much to further his own, which took place in the latter year. Confucius left no work detailing his moral and social system, but the five canonical books of Confucianism are the Yih-king, the Shu-king, the Shi-king, the Le-king, and the Chun-t sien, with which are grouped the 'Four Books,' by disciples of Confucius, the Ta-hëo or Great Study, the Chung-Yung or Invariable Mean, the Tun-yu or 'Philosophical Dialogues,' and the Hi-tse, written by Meng-tse or Mencius. The teaching of

Confucius has had, and still has, an immense influence in China, though he can hardly be said to have founded either a religion or a philosophy. All his teaching was devoted to practical morality and to the duties of man in this world in relation to his fellow-men; in it was summed up the wisdom acquired by his own insight and experience, and that derived from the teaching of the sages of antiquity. It is doubtful if he had any real belief in a personal god.

Congé d'Elire (kōn-zhā dā-lēr), the Norman French for 'leave to elect,' designates the sovereign's license authorizing the dean and chapter of a vacant see in England to proceed with a new election. Though nominally choosing their bishop, yet the dean and chapter are bound to elect, within a certain time, such person as the crown shall recommend, otherwise they incur the penalties of a *præmunire*.

Conger-eel (kong'gër), a genus of marine eels characterized by a long dorsal fin beginning near the nape of the neck, immediately above the origin of the pectoral fins, and by having the upper jaw longer than the lower. The best-known member of this genus is the *Conger vulgāris*, sometimes as thick as a man's thigh, frequently attaining a length of 10 feet and more than 100 lbs. in weight. It is pale-brown above, grayish-white below, with whitish dorsal and anal fins fringed with black. Its flesh is eaten, but is somewhat coarse.

Conges'tion, in medicine, an excessive accumulation of blood in an organ, which thereby becomes disordered. Among the causes of congestion are the different periods of development of the human body, each of which renders some particular organ unusually active; diseased conditions; and the accidental exertions of certain organs. Again, if the current of blood to one organ is checked the blood tends to accumulate in another; and the vessels which bring back the blood to the heart—that is the veins—are sometimes obstructed, as by external pressure, by tumours, &c. Congestion sometimes lasts a short time only; but if not early cured, and its return, which would otherwise be frequent, prevented, it is only the beginning of other diseases. Sometimes it terminates in bleeding, which is a remedy for it; sometimes it increases into inflammation; sometimes it becomes a chronic disease, that is, the blood accumulates for a long time and expands the veins, the expansion becomes permanent, and dropsy may result.

Cong'leton, a market town of England, Cheshire, in a deep valley on the Dane, 22 miles s. of Manchester. It has cotton and silk manufactures, the latter forming the principal industry. Pop. 1891, 10,774.

Conglom'erate, a term applied by geologists to rocks consisting mostly of water-worn pebbles cemented together by a matrix of siliceous, calcareous, or other cement, often called also *plum-pudding stone*.

Congo, or **ZAIRE**, one of the great rivers of the world, in Southern Africa, having its embouchure in the South Atlantic. The mouth of the river was known to the Portuguese in 1485, but the lower part of its course was first explored by an English expedition under Captain Tuckey in 1816, which ascended it for about 172 miles. In 1867, however, Livingstone discovered a considerable river called the Chambezi, rising in the Chibalé Hills, and having followed it to Lake Bangweolo traced it thence as the Luapula to Lake Moero, and thence again as the Lualaba to Nyangwe. From this point its exploration was taken up in 1876-77 by Stanley, who proved its identity with the Congo. It carries more water to the ocean than the Mississippi, its volume being next to that of the Amazon. Its total length is perhaps 3000 miles. Its chief tributaries are the Aruwimi and the Mobangi from the right, and the Ikelemba and Kwa from the left, which latter represents the collected waters of immense rivers from the south, such as the Kassai, the Kwango, &c. It is navigable for about 110 miles from its mouth, after which the navigation is interrupted by cataracts. See next article.

Congo Free State, a state recently founded on the river Congo, in Central South Africa, stretching by a kind of narrow neck of territory to the river's mouth, but expanding inland so as to cover an immense area, mainly lying south of the river. The obvious advantages of the Congo as a waterway in opening up the continent led to the formation at Brussels in 1878 of a Comité d'Études du Haut Congo, under the patronage of Leopold II., having as its aim the internationalization and development of the Congo area. Under its auspices Stanley returned in 1879 (see preceding art.) to open up the river and form a free state under European auspices. He established a first station at Vivi, the limit of maritime navigation, 110 miles above the mouth of the river, constructed roads past the Yelala and Livingstone cataracts, and hauled

steamers up to the higher reaches of the Congo, where in 1882 the station of Leopoldville was formed on Stanley Pool. Of the 223 miles between Vivi and Leopoldville only 88 are navigable water; but from the latter station to Stanley Falls the Congo itself is continuously navigable for 1000 miles, to which its great affluents already explored add no fewer than 5000 miles of serviceable water-way. Above the Stanley Falls station (destroyed by Arab slave-dealers in Nov. 1886) the river is again navigable for a distance of 385 miles to Nyangwe, which is about 1300 miles from the Chambezi sources. The work having been thus initiated by Stanley, and the feasibility of the project made manifest, the association in 1884-85 entered into treaties with all the European powers and the United States for the recognition of its sovereign power. The boundaries of the new CONGO FREE STATE were settled at the same time, it being agreed that the basin of the Congo and its tributaries should be free to all nations, that no duties should be levied on imports, and that the slave-trade should be suppressed. The central government is at Brussels, consisting of the King of Belgium as sovereign, and three departmental chiefs. Arrangements are being made for the construction of a railway past the falls obstructing navigation. A number of stations have been formed on the river, the chief of which is Boma, about 70 miles from its mouth. The revenue at present largely consists of a subsidy from King Leopold. The exports forming the staple of present trade are palm-oil, caoutchouc, ivory, orchilla, copal, ground-nuts, camwood, wax, &c. Area estimated at 1,000,000 sq. miles; pop. 17,000,000.

Congo Pea. See *Pigeon Pea*.

Congrega'tionalists, formerly called Independents, a Christian sect claiming to continue the primitive form of church government; founded by the moderate party among the Brownists and Barrowists early in the 17th century. Under the Commonwealth they rapidly developed, and though they suffered after the Restoration, in common with their rivals the Presbyterians, they speedily recovered after the Revolution, and soon outstripped the latter sect so far as England was concerned. The name Independent, as it was frequently adopted by other bodies with which they had no sympathy, was discarded in favour of the name of Congregational Brethren, which appeared

to express a leading feature in their polity. This is the government of each congregation by all the members of that congregation, and not, as in the Presbyterian church, by a session of the pastor and ruling elders only. Moreover each congregation is autonomous and wholly independent of extraneous jurisdiction, the union of Congregational churches having only such indirect authority as attends the cumulative expression of opinion. In doctrine the majority are evangelical, though in individual churches considerable latitude is shown. The number of Congregational churches and mission stations in the British Islands is about 4600, of which more than 4300 are in England and Wales. The body has about 2800 accredited ministers and upwards of 300 evangelists, and it raises a sum of more than £1,000,000 annually for religious and charitable purposes. Congregationalism is also a leading form of church life in many of the British dependencies and in the United States.

Congregations, in the Papal government, meetings or committees, consisting of cardinals and officers of the pope, to administer the various departments, secular and spiritual, of the Papal dominion, *e.g.* the congregation of the Holy Office (Inquisition), the congregation of the Index, &c. Congregation also signifies a society of several convents of the same rule, which together form an organized corporation, hold chapters, and elect superiors.

Con'gress, in international politics, a meeting of the rulers or representatives of several states, with a view of adjusting disputes between different governments.

Congress, the name given to the legislative assembly of the United States of America, consisting of two houses—a Senate and a House of Representatives. The Senate consists of two members elected by each state for a period of six years, one-third of whom are elected every two years. The representatives in the lower house are elected by the several states every two years, and their number varies in each state in proportion to the population as determined by the decennial census. The united body of senators and representatives for the two years during which the representatives hold their seats is called one Congress. See *United States*.

Con'greve, WILLIAM, English dramatist, born 1670, educated at Kilkenny, and at Trinity College, Dublin, from which he entered the Middle Temple, London. A novel

entitled the *Incognita*, under the pseudonym of Cleophil, was followed, at the age of twenty-one, by his comedy of the *Old Bachelor*, the success of which procured for him the patronage of Lord Halifax, who made him a commissioner for licensing hackney-coaches; soon after gave him a place in the pipe office; and finally conferred on him a very lucrative place in the customs. He afterwards received an additional sinecure in the appointment of secretary to the island of Jamaica. His next play, the *Double Dealer*, was less successful; his third comedy, *Love for Love*, and his tragedy *The Mourning Bride* (1679), were both popular; but after the cold reception of his *Way of the World*, in 1700, he ceased altogether to write for the stage. He, however, continued to write occasional verses on public subjects; and in 1710 published a collection of his plays and poems, which he dedicated to his early patron, Lord Halifax, to whose person and party he remained attached in all fortunes. He died in 1729. His plays belong to the artificial school of comedy, which aimed rather at the production of a sustained flow of wit than at the precise delineation of character.

Congreve, SIR WILLIAM, BART., inventor of the Congreve rocket, was born in 1772, and entered the army, from which he retired in 1816 with the rank of lieutenant-colonel of artillery and entered the House of Commons. He invented the rocket about 1804. It was first used in active service in the attack on Boulogne, 1806, and on Copenhagen, 1807. He took out patents also for the manufacture of gunpowder and of bank-note paper, and wrote treatises on the mounting of naval ordnance and on the hydro-pneumatic lock. He died at Toulouse in 1828.

Congreve Rocket. See *Rocket*.

Coni, or CU'NEO, a town of North Italy, capital of the province of Coni, charmingly situated on a hill, at the confluence of the Stura and the Gesso, 47 m. s. Turin. Formerly all merchandise passing from the seaport of Nice to Lombardy, Switzerland, and Germany went by this route, but the railway has confined its trade to Turin and neighbouring towns. It has manufactures of silks and woollens. Pop. 12,413.

Conia, CONIINE, CICUTINE (C₈H₁₇N), a volatile alkaloid, the active poisonous principle of hemlock. It exists in all parts of the plant, but especially in the not quite ripe seed. When pure it is a colourless oily

CONIC SECTIONS — CONJUGAL RIGHTS.

liquid, specific gravity 0.878, changing by exposure to air to a brown fluid, and ultimately to a resinous bitter mass, insoluble in water but soluble in alcohol, and when purified yielding a jelly with a butyric odour. It has a nauseous taste and very disagreeable odour, sharp and choking when strong, but in small quantity like that of mice. It is exceedingly poisonous, appearing to cause death by inducing paralysis of the muscles used in respiration.

Conic Sections, three curves, the hyperbola, the parabola, and the ellipse, so called because they are formed by the intersection

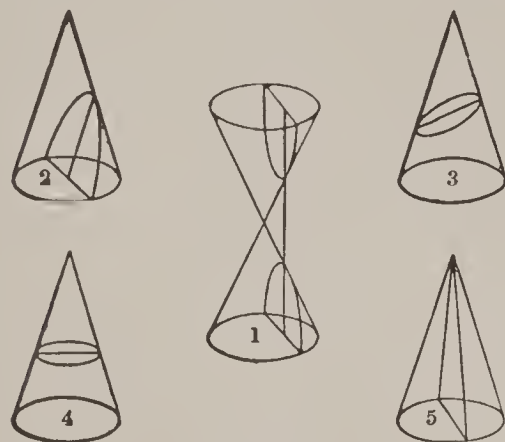

Conic Sections.

of the surface of a cone with planes that cut the cone in various directions. If the cutting-plane be parallel to the axis the curve formed is the hyperbola (1); if parallel to the slope of the cone the curve is a parabola (2); if passing through both sides of the cone obliquely the section is an ellipse (3). A section perpendicular to the axis of the cone forms a circle (4), which may also be considered one of the conic sections. A perpendicular plane through the apex gives a triangle (5).

Conid'ia, in botany, the simple dust-like asexual reproductive cells produced on some lichens and fungi, as in the potato blight.

Conif'eræ, the pines, firs, and their allies, a natural order of gymnospermous exogens, the essential character of which consists in the manner in which the ovules, not inclosed in an ovary, receive directly the action of the pollen without the intervention of a stigma. The ovules in these plants are borne on scales or modified leaves, which are spread out, not folded, and generally grouped in such a manner as to form a *cone* composed of a greater or smaller number of these leaves, of which only a portion may be fertile and bear ovules. The disposition of the ovules in relation to these scales permits of

a division of the Coniferæ into three distinct families or tribes. In the *Cupressineæ*, which include the juniper, cypress, &c., the cones are formed of simple scales, each of which bears towards the base of its superior surface the ovules erect and sessile. The second family, *Abietineæ*, has in place of simple scales, scales actually double or formed of two parts; the lower one usually designated the bract; the other bearing at its base the ovules reversed. This family includes the pines, firs, and larches, the araucarias, Wellingtonias, dammaras, &c. In these two families the ovules are completely covered by the scales which constitute the cones, which unite after fecundation, and inclose the seed till their maturity. In the *Taxineæ*, which constitute the third family, the scales are short, imperfect, and partly sterile, and neither cover the ovules at the period of fecundation nor at that of maturation. The ovules are usually set in the same manner as in the *Cupressineæ*. The yew, the ginkgo, &c., belong to this family. The Coniferæ are found in large forests in the north of Europe and America, and are of great importance as timber trees. They abound also in resinous juices and yield turpentine, pitch, tar, succinic acid, &c. The leaves are usually alternate, and awl or needle shaped, the naked flowers are monœcious or diœcious, the male flowers being in deciduous catkins, the female in cones.

Coniine (kon'i in). See *Conia*.

Coniros'tres, in ornithology, a subdivision of the order Insectores or Passeres, consisting of genera having a stout conical beak. The best-known genera are the larks, tits, finches, sparrows, goldfinches, linnets, bullfinches, crossbills, starlings, crows, and birds of parad' e.

Conium, a genus of umbelliferous plants. See *Hemlock*.

Conjev'eram, a town of Hindustan, presidency of Madras, district of Chingleput. It stands in a valley, is irregularly built, and from 5 to 6 miles long. It possesses two famous pagodas dedicated to Vishnu and Siva, and the inhabitants are mostly Brahmans. The name 'Benares of the South' has been sometimes given to it. Cottons are manufactured in the town, in which there is a large Free Church of Scotland mission school. Pop. 37,275.

Con'jugal Rights, in law, the right which husband and wife have to each other's society, comfort, and affection. A suit for res-

titution of conjugal rights is competent by either party.

Conjugation. See *Verb*.

Conjunct'ion, in grammar, a connective indeclinable particle serving to unite words, sentences, or clauses of a sentence, and indicating their relation to one another. They are classifiable into two main groups: (1) Co-ordinating conjunctions, joining independent propositions, and subdivisible into copulative, disjunctive, adversative, and illative conjunctions; (2) Subordinating conjunctions, linking a dependent or modifying clause to the principal sentence. The only active influence which the conjunction can be said to exercise grammatically in a sentence is in respect of the mood of the verb following it in dependent sentences, the rule being to employ the subjunctive where futurity and contingency are implied, the indicative where they are not; as 'I will do it though he be there' (which he may or may not be); or 'I will do it, though he is there' (which he is).

Conjunct'ion, in astronomy, the position of two of the heavenly bodies, as two planets, or the sun and a planet, when they have the same longitude (are in the same direction from the earth). When it is simply said that a planet is *in conjunction*, conjunction with the sun is to be understood. *Superior* conjunction and *inferior* conjunction are terms used of the planets whose orbits are nearer to the sun than that of the earth, according as the sun is between us and them, or they between us and the sun.

Conjuncti'va, the mucous membrane which lines the inner surface of the eyelids and is continued over the fore-part of the globe of the eye.

Con'juring. See *Legerdemain*.

Conn, LOUGH, a lake in the north of Mayo county, Ireland, separated from Lough Cullin by a narrow channel. The two extend for about 13 miles and are studded with islands.

Connaught (kon'nat), the smallest of the four provinces of Ireland, situated between Leinster and the Atlantic; area, 4,392,086 acres. Its west coast is much broken up by numerous bays and inlets, and is thickly studded with islands. The central parts are comparatively level and of limestone formation, while the surrounding and picturesque mountains are formed of sandstone, clay-slate, granite, and quartz. A large proportion of the province is bog, and, generally,

it is the least fertile of all the provinces. It is divided into five counties—Galway, Mayo, Roscommon, Leitrim, and Sligo. Pop. 1891, 723,573.

Connecticut (kon-net'i-kut), a river, U. States, the west branch of which forms by treaty the boundary between the U. States and Canada to lat. 45° N. It rises on the north border of New Hampshire; forms the boundary between Vermont and New Hampshire, passes through the west part of Massachusetts and the central part of Connecticut, and falls into Long Island Sound. It is navigable for vessels drawing from 8 to 10 ft. for about 300 miles from its mouth, subsidiary canals, however, being required above Hartford; total length, 450 miles. It is famed for its shad fisheries.

Connecticut, one of the original thirteen states of the American Union; bounded by New York, Massachusetts, Rhode Island, and Long Island Sound; length, east to west, about 95 miles; greatest breadth, north to south, about 72 miles; area, 4990 sq. miles. It contains several distinct ranges of hills, but none of them have any great elevation. Its principal river is the Connecticut, which divides it into two nearly equal parts. The coast is indented with numerous bays and creeks, which furnish many harbours. Its minerals comprise iron, copper, lead, cobalt, plumbago, marble, free-stone, porcelain-clay, and coal. Lime is produced in large quantities, and there is abundance of building-stone. The soil is in general better suited for grazing than tillage, abounding in fine meadows. But where agriculture is practised there are ample crops of Indian corn, rye, wheat, oats, barley, buckwheat, potatoes, &c.; and fruits, particularly apples, flourish. The manufactures consist chiefly of woollen, cotton, and silk goods, metal goods, paper, clocks, hats and caps, leather goods, pottery-ware, glass, and machinery, firearms, sewing-machines, soap, candles, bricks, carriages, &c. The principal exports consist of agricultural produce and manufactures. The foreign commerce is nearly all carried on through New York and Boston, but there is a considerable coasting trade, and a large amount of tonnage engaged in the cod fisheries. Fish-culture has received special attention, many millions of shad ova and young salmon having been introduced into the rivers. The number of miles of railway in operation is over 1000. The chief educational institution is Yale College, one of the most cele-

brated in the States. Connecticut is divided into eight counties; the seat of government is Hartford. The state at first consisted of two colonies—Connecticut, with its seat of government at Hartford; and Newhaven, at Newhaven. Connecticut was settled in 1633 by emigrants from Massachusetts. Hartford was settled by English in 1635, the Dutch having previously built a fort there. The colony of Newhaven was settled by English

in 1638, and the two colonies were united in 1665. Pop. 1890, 746,258.

Connellsville, Pa., manufactures immense quantities of the best coke. Pop. 5623.

Connema'ra ('the Bays of the Ocean'), a boggy and mountainous district occupying the west portion of county Galway, Ireland; about 30 miles in length and 15 to 20 miles in breadth. Its coasts are very broken, and there are numerous small lakes. It is sub-



Scene in Connemara—Going to Market.

divided into Connemara Proper in the west, Jar-Connaught in the south, and Joyce Country in the north.

Co'noid, in geometry, a solid formed by the revolution of a conic section about its axis. Thus the solid resulting from a parabola is a parabolic conoid or paraboloid; if a hyperbola, a hyperbolic conoid or hyperboloid; &c.

Co'non, an Athenian who had the command of a fleet in 413 B.C. to prevent the Corinthians from relieving Syracuse, then at war with Athens, and who, after various services, succeeded Alcibiades in 406. When the Athenian fleet was surprised and Athens captured by Lysander in 405 Conon escaped to Cyprus, and afterwards joined the Persians against the Spartans, being appointed to the command of a Persian fleet in 397. In 394, with Pharnabazus he defeated the Spartan admiral Pisander off Cnidus, and in 393 returned to Athens to restore the walls and fortifications. But having been sent by the

Athenians to counteract the effects of Spartan diplomacy upon the Persians, he was thrown by the latter into prison, and his subsequent fate is unknown.

Conquest, in feudal law, a name applied to purchase or any other means of acquiring property than by the common course of inheritance.

Con'rad II., king of Germany and emperor of the Romans, reigned from 1024 to 1039, and is regarded as the true founder of the Franconian or Salic line. On his election he proclaimed a *God's Truce* in order to attempt certain reforms in the kingdom; but his attention was too distracted between Italy and Germany for him to do more than repress some of the more marked evils of the feudal system.

Conrad III., king of Germany and emperor of the Romans from 1138 to 1152, was the founder of the Suabian dynasty of Hohenstaufen. During the struggle with his rival Henry the Proud the factions of Gueif

and Ghibelline, named from the war-cries of the respective parties, came into existence. Conrad, persuaded by St. Bernard, took part in the second crusade, from 1147 to 1149. His marriage with a Greek princess led to his adoption of the double-headed eagle now appearing on the Austrian arms. He was succeeded by his nephew Frederick Barbarossa.

Consalvi, ERCÖLE, cardinal and prime-minister of Pope Pius VII., born in 1757. He became secretary of Cardinal Chiaramonti, and when his patron was elected pope (Pius VII.) became one of the first cardinals, and afterwards secretary of state. In this capacity he concluded the famous concordat with Napoleon in 1801. In 1806 he went into retirement, but in 1814 became Papal minister at the Congress of Vienna, and up till the death of Pius VII. he remained at the head of Roman political and ecclesiastical affairs. He died in 1824.

Consanguin'ity, the relation of persons descended from the same ancestor. It is either lineal or collateral—lineal between father and son, grandfather and grandson, and all persons in the direct line of ancestry and descent, from one another; collateral between brothers, cousins, and other kinsmen descended from a common ancestor, but not from one another.

Conscience, that power or faculty, or combination of faculties, which decides on the rightness and wrongness of actions; otherwise called the *Moral Sense*. Whewell defines it as 'the reason, employed about questions of right and wrong, and accompanied with the sentiments of approbation and condemnation, which, by the nature of man, cling inextricably to his apprehension of right or wrong.' See *Ethics*.

Conshohocken, Pa., 13 m. N. W. of Philadelphia, on Schuylkill river, has waterworks, fire and police departments, iron manufactories, woollen and cotton mills. Pop. 5469.

Conscience (kōn-syāns), HENDRIK, Flemish novelist, born at Antwerp 1812, died 1883. Having educated himself he taught for a short time in a school, and then served in the army for six years. He was for a time tutor in Flemish to the royal princes, and from 1868 conservator of the Wiertz museum at Brussels. His novels, some of which have been translated into English, are partly based on the history of his country, partly pictures of everyday Flemish life. They include *The Lion of Flanders*; *Jakob*

van Artevelde; *Batavia*; *Wooden Clara*; *Blind Rosa*; *The Poor Nobleman*; *The Young Doctor*; *Maternal Love*; &c. He also wrote a *History of Belgium*.

Consciousness, a term used in various senses, most commonly perhaps to denote the mind's knowledge or cognizance of its own action.

Conscrip'tion, the enlisting of the inhabitants of a country capable of bearing arms, by a compulsory levy, at the pleasure of the government, being thus distinguished from *recruiting*, or voluntary enlistment. The word and the system were both introduced into France in 1798 by a law which declared that every Frenchman was a soldier, and bound to defend the country when in danger. Excepting in times of danger it provided that the army should be formed by voluntary enrolment or by *conscription*. The conscription included all Frenchmen from twenty years of age complete to twenty-five years complete. On the restoration of the Bourbons conscription was abolished. It was, however, re-enacted, and continued through the Second Empire to form the mode of recruitment in France. An army-bill, passed by the National Assembly in 1872, affirms the universal liability to conscription, but allows certain exceptions and postponements. The term of service is fixed at five years in the active army, four years in the reserve of the active army, five years in the territorial army, and six years in its reserve—the total length of military service being thus twenty years. Universal liability to military service is also the law in Germany, Italy, and Austria. In Germany the total length of service is twelve years. Twelve years' service is also the period in Austria. The Russian army has long been partly raised by conscription, and by a law which came into force in 1872 an annual conscription was established, to which all men who have completed their twenty-first year, and are not physically incapacitated, are liable. The men have to serve in the active army six years, after which they pass into the reserve for other nine years, during which they are liable to active service only in time of war. In Great Britain a small militia obtained, if necessary, by conscription is usually kept up in time of peace, but the regular army and navy are recruited by voluntary enlistment.

Consecre'tion, the dedication with certain rites or ceremonies of a person or thing to the service of God; especially (1) the ordina-

tion of a bishop or archbishop, which requires the co-operation of at least three bishops; (2) the dedication of a church to God's service, which is practised in the Anglican and Roman Catholic churches and is performed by a bishop; (3) the act of the priest in celebrating the eucharist by which the elements are solemnly dedicated to their sacred purpose.

Consent', in law, is understood to be a free and deliberate act of a rational being. It is invalidated by any undue means—intimidation, improper influence, or imposition—used to obtain it. Idiots, pupils, &c., cannot give legal consent; neither can persons in a state of absolute drunkenness, though partial intoxication will not afford legal ground for annulling a contract.

Consequen'tial Damages, in law, are such losses or damages as arise out of a man's act, for which, according to a fundamental principle in law, he is answerable if he could have avoided them. The same law applies to railways and corporations generally, as determined in numerous cases.

Conser'vatives, in British politics, the party that substantially corresponds to what used to be the Tory party, taking the opposite side to the *Liberals*. The name came into use about the time of the passing of the Reform Act of 1832, and is often used as implying greater enlightenment or liberality than *Tory*.

Conser'vatory, a name given on the European continent to a systematic school of musical instruction. In Britain the term is usually applied to foreign schools of music. Conservatories were originally benevolent establishments attached to hospitals, or other charitable or religious institutions. In Naples there were formerly three conservatories for boys; in Venice four for girls; the Neapolitan group being reduced in 1818 to a single establishment under the name Royal College of Music. In Milan a conservatory was established in 1808. In France the musical school established in connection with the Opera received its final organization in 1795 under the name of *Conservatoire de Musique*. Among its teachers have been Méhul, Cherubini, Grétry, Boieldieu, &c. The Conservatorium, founded at Leipzig in 1842 under the auspices of Mendelssohn, is perhaps the most influential in Germany, though of late years other schools have pressed closely upon it. Institutions of the same description exist

in Warsaw, Prague, Munich, Berlin, and Vienna.

Conser'vatory, in gardening, a term generally applied by gardeners to plant-houses, in which the plants are raised in a bed or border without the use of pots, the building being frequently attached to a mansion. The principles of their construction are in all respects the same as for the greenhouse, with the single difference that the plants are in the free soil, and grow from the floor instead of being in pots placed on shelves or stages. The distinction, however, is often overlooked.

Con'serve, a form of medicine in which flowers, herbs, fruits, roots, are preserved as nearly as possible in their natural fresh state.

Considera'tion, in law, the reason or substantial ground which induces a party to enter into a contract; the equivalent for something given, done, or suffered. It may be either expressed or implied, that is, where justice requires it and the law implies it.

Consign'ment, a mercantile term which means either the sending of goods to a factor or agent for sale, or the goods so sent. The term is chiefly used in relation to foreign trade. The receivers of consignments have usually to keep magazines and stores, for the use of which their consigners are charged. The profits of a consigning agency often compare favourably with the occasionally larger but much less safe profits of original ventures. The consigning trade is protected by special laws. In most countries a consigner can claim his goods and collect all outstanding debts for goods sold on his account by a consignee who has suspended payment.

Con'sistory, the highest council of state in the Papal government. The name is also applied to the court of every diocesan bishop, held in their cathedral churches for the trial of ecclesiastical causes arising within the diocese. In the English Church the consistory is held by the bishop's chancellor or commissary and by archdeacons and their officials either in the cathedral church or other convenient place in the diocese.

Consola'to del Mare (It., lit. 'the consulate of the sea'), an ancient code of maritime law, supposed to be a compilation of the law and trading customs of various Italian cities, as Venice, Genoa, Pisa, and Amalfi, together with those of the cities with which they traded, as Barcelona, Marseilles, &c.

It has formed the basis of most of the subsequent compilations of maritime laws.

Con'sole, in architecture, a projecting ornament or bracket having for its contour generally a curve of contrary flexure. It

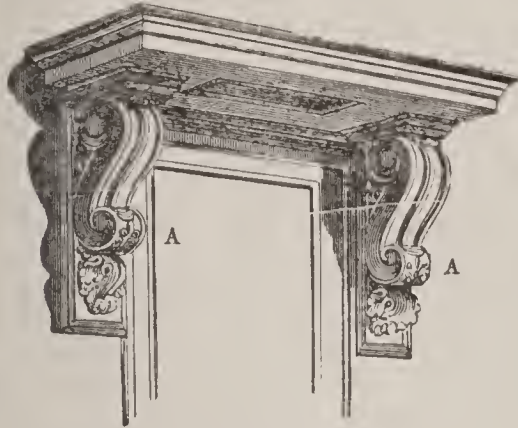

Cornice supported by Consoles, A A.

is employed to support a cornice, bust, vase, or the like, but is frequently used merely as an ornament.

Consolidated Fund, the fund which now receives the produce of nearly all the taxes and other sources of revenue of Great Britain and Ireland, formed in 1787 by the union of certain separate funds. On the union of the exchequers of Great Britain and Ireland, in 1816, the fund was augmented with the separate revenue of the Irish exchequer, and the charges hitherto made upon that exchequer were thrown upon it. The fund is liable from time to time to have specific charges thrown upon it by parliament; it is pledged for the payment of the interest of the whole of the national debt of Great Britain and Ireland, and after defraying the specific charges assigned to it the surplus is applied indiscriminately under the direction of parliament to the public service. The stated charges upon the consolidated fund, besides the national debt, are the civil list, pensions, annuities, salaries, courts of justice, and miscellaneous charges.

Con'sols, or CONSOLIDATED ANNUITIES, a public stock forming the greater portion of the national debt of Great Britain. It was formed in 1751 by an act consolidating several separate stocks bearing interest at 3 per cent into one general stock. At the period when the consolidation took place the principal of the funds united amounted to £9,137,821; but through the addition of other loans it has increased so much that now, after considerable reductions, it still amounts to more than half of the national

debt. The interest of about five million pounds is payable in Dublin, that of the remainder in London.

Con'sonance, in music, an agreeable accord of sounds, such as the third, fifth, and octave. See *Concord*.

Con'sonant (L. *con*, with, *sonare*, to sound), a letter so named as being sounded only in connection with a vowel, though some consonants have hardly any sound even when united with a vowel, serving merely to determine the manner of beginning or ending the vowel sounds; as in *ap*, *pa*, *at*, *ta*. In uttering a consonant there is greater or less contact of some parts of the organs of speech; in uttering a vowel there is a want of such contact, the vocal passage being open though variously modified. They are classed as *liquids*, *mutes*, *sibilants*, *labials*, *dentals*, *palatals*, *gutturals*, &c.

Conspir'acy, in law, an offence ranked as a misdemeanour, and punishable by imprisonment and hard labour. It is constituted by a combination between several persons to carry into effect any purpose injurious either to individuals, particular classes, or the community at large. When the conspiracy leads to any overt act of an unlawful kind, the offence becomes felony.

Con'stable (Fr. *connétable*; Old Fr. *constable*; Lat. *comes stabuli*, count of the stable), an officer of high rank in several of the mediæval monarchies. Among the Franks, after the *major domus*, or mayor of the palace, had become king, the *comes stabuli* became the first dignitary of the crown, commander-in-chief of the armies, and highest judge in military affairs. The *connétable*, however, acquired so much power that Louis XIII. in 1627 abolished the office entirely. Napoleon re-established it, but it vanished with his downfall. In England the office of *lord high constable* was created by William the Conqueror, and became hereditary in two different families, as annexed to the earldom of Hereford. Since the attainder of Stafford, however, lord high constables have been appointed only to officiate on special occasions. The office of lord high constable of Scotland, expressly reserved in the treaty of union, is hereditary in the noble family of Errol.

In the common modern acceptation of the term constables are police officers in towns, counties, &c., having as their duties the repression of felonies, the keeping of the peace, the execution of legal warrants, &c. In case of special disturbance a certain num-

ber of private citizens may be sworn in as *special constables*. In the U. S. a constable is usually the acting bailiff of a justice of the peace; serving writs, executing judgments, making distrainments, etc.

Con'stable, ARCHIBALD, Scottish bookseller and publisher, born in 1774. He was the original publisher of the Edinburgh Review, the poems of Sir Walter Scott, the Waverley Novels, the Supplement to the Encyclopædia Britannica, and other valuable works. In 1825 he projected the well-known series of works, Constable's Miscellany. In 1826, however, the firm was compelled to stop payment with liabilities exceeding £250,000. Sir Walter Scott, who was heavily involved, practically sacrificed his life in the endeavour to meet his creditors, and Constable himself died in 1827.

Constable, HENRY, Elizabethan poet, born in 1556, educated at Cambridge. His chief work was his book of sonnets, *Diana*, published in 1592 when few sonnets in the Italian form had been written. He was probably the author also of the *Forest of Fancy* (1579), attributed to Chettle. Suspected of treason against Elizabeth, he was compelled to leave the country in 1595, and on his return in 1601 was confined in the Tower for three years. Date of death is unknown.

Constable, JOHN, English landscape-painter, born in 1776. He was employed in the business of his father, a wealthy miller, for some years, but entered as a student of the Royal Academy in 1799. It was not till 1814, twelve years after he had begun to exhibit pictures, that he succeeded in getting any of them sold. In 1819 his *View on the River Stour* procured him admission as an associate of the Academy. From this period his reputation widely extended itself, both over Britain and the Continent, and for some of his works exhibited at the Louvre he received a gold medal from the King of France. He died in 1837. His careful studies of landscape in respect of tone were of great influence in art, especially in France, which derived its best landscape work from him.

Con'stance, a town of Germany, in Baden, on the south bank of the Lake of Constance, at the outflow of the Rhine into the Lower Lake or Untersee, its chief edifices being a magnificent cathedral, several churches, the Kaufhaus (merchant-house), an ancient palace, a grand-ducal residence, several convents, a theatre, &c. The town has various branches of industry and a considerable trade. It was once a flourishing imperial

city with three times its present pop. Pop. 1890, 16,235.

Constance, COUNCIL OF, a general council of the Church of Rome, held between 1414 and 1418. The German emperor, the pope, 26 princes, 140 counts, more than 20 cardinals, 7 patriarchs, 20 archbishops, 91 bishops, 600 other clerical dignitaries and doctors, and about 4000 priests, were present at this assembly, which condemned to death Huss and Jerome of Prague, expelled the rival popes John XXIII., Gregory XII., and Benedict XIV., and elected Martin V. to the papal chair.

Constance, LAKE OF (anc. *Lacus Brigantinus*; Ger. *Bodensee*), a lake, Central Europe, in which Switzerland, Baden, Würtemberg, Bavaria, and Austria meet; forming a reservoir in the course of the Rhine; length N.W. to S.E. 42 miles, greatest breadth about 8 miles; area 207 sq. miles; greatest depth (between Friedrichshafen and Uttwil) 838 ft.; 1283 ft. above sea-level. At its N.W. extremity the lake divides into two branches or arms, each about 14 miles in length; the north, called the Überlingersee, after the town of Überlingen, on its north bank; the south the Zellersee or Untersee, in which is the fertile island of Reichenau, belonging to Baden, about 3 miles long and 1½ broad. The lake, which is of a dark-green hue, is subject to sudden risings, the causes of which are unknown. It freezes in severe winters only. The traffic on it is considerable, there being numerous steamers. The shores are fertile but not remarkably picturesque.

Constant de Rebecque (kōn-stān-d-rè-bek), HENRI BENJAMIN, born at Lausanne 1767; prominent French liberal politician. During the revolution he distinguished himself by his works upon politics and on revolutionary subjects, and was elected to the office of tribune; but his speeches and writings rendered him odious to the First Consul, and he was dismissed in 1802. He died in 1830.

Constant, BENJAMIN, portrait painter, was born at Paris in 1845. He studied in the Ecole des Beaux Arts and under Cabanel. He has exhibited with growing distinction, at successive salons, from that of 1860 with his "Hamlet," his "Samson" in 1872, his "Scenes from Algiers" in 1873-4, his great historical painting of "Mohammed II. in 1453" in the Exposition of 1878, and in 1885 a large oriental subject, as melo-dramatic as possible, with splendid rendering of the human figure and strong effects of color. His noble picture of "Jus-

tinian" is in the Metropolitan Art Museum, New York. He was decorated with the Legion of Honor in 1878. He is (1893) a candidate to the French Academy of Fine Arts.

Constan'tia, a small district in Cape Colony a few miles from Cape Town, celebrated for its wine, made from vines brought originally from Persia and the Rhine, esteemed the best liqueur wine after Tokay, and owing its special properties largely to the soil.

Con'stantine, a town in Algeria, capital of a province of same name, on a rocky peninsula, 1968 ft. above the sea, and accessible only on one side. It is surrounded by walls, and the only edifice deserving notice is the palace of the bey, now the residence of the French governor. Both within the town and in the vicinity Roman remains abound, the town having been built by the emperor whose name it bears, on the site of Cirta, the capital of the Numidian kings. The manufactures consist chiefly of woollen and linen goods; the trade is in corn, linen, and wax. Pop. 44,960.

Con'stantine, CAIUS FLAVIUS VALERIUS AURELIUS CLAUDIUS, Roman emperor, surnamed the *Great*, son of the Emperor Constantine Chlorus, was born A.D. 274. When Constantine's father was associated in the government by Diocletian, the son was retained at court as a hostage, but after Diocletian and Maximian had laid down the reins of government, Constantine fled to Britain, to his father, to escape from Galerius. After the death of his father he was chosen emperor by the soldiery, in the year 306, and took possession of the countries which had been subject to his father, namely, Gaul, Spain, and Britain. He more than once defeated the Franks who had obtained a footing in Gaul and drove them across the Rhine; and then directed his arms against Maxentius, who had joined Maximian against him. In the campaign in Italy he saw, it is said, the vision of a flaming cross in the heavens, beneath the sun, bearing the inscription, '*In hoc signo vinces.*' Under the standard of the cross, therefore, he vanquished the army of Maxentius under the walls of Rome, and entered the city in triumph. In 313, together with his son-in-law, the eastern emperor, Licinius, he published the memorable edict of toleration in favour of the Christians, and subsequently declared Christianity the religion of the state. Licinius, becoming jealous of his fame, twice took up arms against him, but was on each occasion defeated, and finally

put to death. Thus in 325 Constantine became the sole head of the Roman Empire. His internal administration was marked by a wise spirit of reform, and by many humane concessions with regard to slaves, accused persons, widows, &c. In 329 he laid



Constantine.

the foundation of a new capital of the empire, at Byzantium, which was called after him Constantinople, and soon rivalled Rome herself. In 332 he fought successfully against the Goths, relieved the empire of a disgraceful tribute which his predecessors had paid to these barbarians, and secured his frontier upon the Danube. In 337 he was taken ill near Nicomedia, was baptized, and died after a reign of thirty-one years, leaving his empire between his three sons, Constantine, Constantius, and Constans. Some of the martyrologists have counted him among the saints, and fix the 20th of May as his festival. The Greeks and Russians observe it upon the 21st of the same month.

Constantine, PAULOVITCH, Grand-prince of Russia, second son of Paul I., born in 1779. He distinguished himself in 1799 under Suwarroff, and at Austerlitz in 1805; and in 1812, 1813, and 1814 attended his brother, the Emperor Alexander, in all his campaigns. He was afterwards employed in superintending the affairs of the new Kingdom of Poland, and was successively made military governor and generalissimo of the Polish troops. On the decease of his brother in 1825 he was proclaimed emperor at St. Petersburg, in his absence, but as he

CONSTANTINOPLE.

adhered to a previous renunciation of claim to the throne, his younger brother, Nicholas, became Alexander's successor. He died in 1831, execrated by the Poles as one of their most barbarous oppressors.

Constantino'ple ('city of Constantine'), called by the Turks *Stamboul*, from the Greek *eis tēn polin*, into the city', a celebrated city of Turkey in Europe, capital of the Turkish Empire, situated on a promontory jutting into the Sea of Marmora, having the Golden Horn, an inlet of the latter, on the north and the Bosphorus on the east. The city proper is thus surrounded by water on all sides excepting the west, where is an ancient and lofty double wall of 4 miles in length, stretching across the promontory. On the opposite side of the Golden Horn are Galata, Pera, and other suburbs, while on the Asiatic side of the Bosphorus entrance is Skutari. Occupying the extreme point of the promontory on which the city stands is the Seraglio or palace of the sultan, which, with its buildings, pavilions, gardens, and groves, includes a large space. At the principal entrance is a large and lofty gate, called Bab Humayum, 'the high door' or 'sublime porte,' from which has been derived the well-known diplomatic phrase. Of the 300 mosques, the most remarkable are the royal mosques, of which there are about fifteen, esteemed the finest in the world. First among these is the mosque

of St. Sophia, the most ancient existing Christian church, converted into a mosque in 1453 on the capture of the city by the Turks. Another magnificent mosque is that of Soliman; after which are those of the Sultana Valide, built by the mother of Mohammed IV., and of Sultan Achmet, the most conspicuous object in the city when viewed from the Sea of Marmora. The streets are mostly extremely narrow, dark, dirty, and ill paved, and exceedingly crooked and tortuous, but there has been a certain opening up and improvement in the last twenty years owing to the construction of tramways and the railway to Adrianople, which runs along the shore of the Sea of Marmora and past the Seraglio to

the entrance of the Golden Horn. The numerous covered and uncovered bazaars are severally allotted to particular trades and merchandise. Constantinople has but one remarkable square, called the At-Meidan, occupying the site of the ancient *Hippodrome*. There are about 130 public baths in the city, mostly of marble, of plain exterior, but handsome and com-



modious within. The numerous cemeteries, mostly outside the western wall, have become vast forests, extending for miles round the city and its suburbs. The few manufactures are chiefly confined to articles in morocco leather, saddlery, tobacco-pipes, fez caps, arms, perfumes, gold and silver embroideries, &c. The foreign commerce is considerable. The harbour, the Golden Horn, which more resembles a large river than a harbour, is deep, well-sheltered, and capable of containing 1200 large ships, which may load and unload alongside the quays. It is about 6 miles long, and a little more than half a mile broad at the widest part. Among the imports are corn, timber, cotton stuffs, and other manufactured goods. The ex-

ports consist of silk, carpets, hides, wool, goats'-hair, valonia, &c. The suburb GALATA is the principal seat of foreign commerce. Here are situated the arsenals, the dock-yard, the artillery barracks, &c., extending along the Bosphorus for nearly $1\frac{1}{2}$ mile. It is an ancient place.—PERA occupies the more elevated portion of the promontory of which Galata forms the maritime part. Both it and Galata have now much of the appearance of a modern European town.—TOP-HANEH is situate a little further up the Bosphorus than Galata, of which it forms a continuation. It has a government foundry and arsenal for cannon.—Constantinople occupies the site of the ancient Byzantium, and was named after Constantine the Great, who rebuilt it about A.D. 330. It was taken in 1204 by the Crusaders, who retained it till 1261; and by the Turks under Mohammed II., May 29, 1453—an event which completed the extinction of the Byzantine Empire. See *Byzantine Empire* and *Byzantium*. Pop. (1896), 873,565.

Constantinople, GENERAL COUNCILS OF. These include the second, fifth, sixth, the Trullan, and the eighth. The second was convoked by Theodosius the Great, in 381, to put down the enemies of the Nicene Creed, who had already been restrained by his decrees. The fifth general council was held by the Emperor Justinian in 553, to decide the dispute of the Three Chapters, or three doctrines of the Bishops Theodore of Mopsuestia, Theodoret, and Ibas of Edessa, who were suspected of Nestorianism, and declared heretics by the council. The sixth council, held 680–681, condemned the doctrines of the Monothelites, and declared their leaders heretics. As these two councils made no new ecclesiastical laws, the Emperor Justinian II., in 692, again summoned a general council, which, because it was held in the Trullan Palace, was called the *Trullan Council*. It instituted rigid laws for the clergy, among them those fixing the rank of the patriarchs and the permission of marriage to priests, which were so offensive to the Latin Church that she rejected all the decrees of this council; but in the Greek Church they are still valid. The eighth general council (869–870) declared against the Iconoclasts, deposed Photius, and confirmed St. Ignatius in the see of Constantinople. This council is not recognized by the Greek Church.

Constella'tions are the groups into which

astronomers have divided the fixed stars, and which have received names for the convenience of description and reference. It is plain that the union of several stars into a constellation, to which the name of some animal, person, or inanimate object is given, must be entirely arbitrary, since the several points (the stars) may be united in a hundred different ways, just as imagination directs. The grouping adopted by the Egyptians was accordingly modified by the Greeks, though they retained the Ram, the Bull, the Dog, &c.; and the Greek constellations were again modified by the Romans, and again by the Arabians. At various times, also, Christianity has endeavoured to supplant the pagan system, the Venerable Bede having given the names of the twelve apostles to the signs of the zodiac, and Judas Schillerius having, in 1627, applied Scripture names to all the constellations. Weigelius, a professor of Jena, even grouped the stars upon a heraldic basis, introducing the arms of all the princes of Europe among the constellations. The old constellations have, however, been for the most part retained. Ptolemy enumerated forty-eight constellations, which are still called the *Ptolemaean*. They are the following:—1. The twelve signs of the zodiac (see *Zodiac*). 2. Twenty-one constellations found in the northern hemisphere—the Great Bear (*Ursa Major*), the Little Bear (*Ursa Minor*), Perseus, the Dragon, Cepheus, Cassiopeia, Andromeda, Pegasus, Equulus (Horse's Head), the Triangle, the Waggoner (*Auriga*), Boötes, the Northern Crown (*Corona Boreälis*), Ophiuchus, the Serpent (*Serpentarius*), Hercules, the Arrow (*Sagitta*), the Lyre, the Swan (*Cygnus*), the Dolphin, the Eagle (*Aquila*). 3. Fifteen constellations in the southern hemisphere—Orion, the Whale (*Cetus*), Eridanus, the Hare (*Lepus*), the Great Dog (*Canis Major*), the Little Dog (*Canis Minor*), Hydra, the Cup (*Crater*), the Crow (*Corvus*), the Centaur, the Wolf (*Lupus*), the Altar (*Ara*), the Southern Fish (*Piscis Austrälis*), the Argo, the Southern Crown (*Coröna Austrälis*). Others were subsequently added, this being especially rendered necessary by the increased navigation of the southern hemisphere, and now the different groups of stars have come to be associated with all sorts of animals and objects, including the Camelopard, the Fly, the Air-pump, the Compasses, &c. The different stars of a constellation are marked by Greek letters, α denoting those of the first magnitude, β

those of the second, and so on. Stars of the sixth magnitude are the smallest visible to the naked eye. Several stars have also particular names.

Constipa'tion, the undue retention of the fæces. Its immediate effects are disordered appetite, a dry coated or clammy tongue, thirst, or a disagreeable taste in the mouth, dulness, giddiness, or pain in the head, torpor, irritability, and despondency. Its less immediate effects are cutaneous affections, dyspepsia, colic, hysteria, hæmorrhoids, &c. In most cases it is produced by indigestible food, astringent and stimulating drinks, sedentary habits, excessive indulgence in sleep, &c. The immediate use of purgatives, followed by strict attention to regimen, is in many cases all that is necessary.

Constit'uent Assembly, a name given to the first convention of the delegates of the French nation (1789-91) to distinguish it from the legislative assembly of 1791. It drew up and obtained the acceptance of the first of the famous revolutionary constitutions. The Constituent Assembly of 1848 had a similar aim.

Constitu'tion, the fundamental law of a state, whether it be a written instrument of a certain date, as that of the United States of America, or an aggregate of laws and usages which have been formed in the course of ages, like the English constitution. The ideal constitution is that established by a free sovereign people for their own regulation, though the expediency of other forms at various stages of national development cannot but be recognized. The chief of these are:—1. Constitutions granted by the plenary power of absolute monarchs, or *constitutions octroyées*; such as Louis XVIII.'s *Charte*. 2. Those formed by contract between a ruler and his people, the contract being mutually binding—a class under which, in a great degree, the British constitution must be placed. 3. Those formed by a compact between different sovereign powers, such as the constitutions of the German Empire, of the United Provinces of Holland, and of the Swiss Confederation.

In regard to political principles, constitutions are:—1. Democratic, when the fundamental law guarantees to every citizen equal rights, protection, and participation, direct or indirect, in the government, such as the constitutions of the United States and of some cantons of Switzerland. 2. Aristocratic, when the constitution recognizes privileged classes, as the nobility and

clergy, and intrusts the government entirely to them, or allows them a very disproportionate share in it. Such a constitution was that of Venice, and such at one time those of some Swiss cantons, for instance, Bern. 3. Of a mixed character. To this latter division belong some monarchical constitutions, which recognize the existence of a king whose power is modified by other branches of government of a more or less popular cast. The British constitution belongs to this division.

Constitution, in the Roman Church, a decree of the pope in matters of doctrine. In France, however, this name has been applied, by way of eminence, to the famous bull *Unigenitus* (which see).

Constitutions, APOSTOLIC. See *Apostolic Constitutions of Clarendon.* See *Clarendon.*

Consubstan'tial (Lat. *consubstantiālis*), an equivalent for the Greek term *homoousios*, the true signification of which disturbed the religious world early in the 4th century, as it was supposed to affect the orthodoxy of Christians regarding the Trinity, according as it might be understood rightly or the contrary. The Athanasians, or Trinitarians, at the council of Nice in 325, gave it the meaning indicated in the Nicene Creed, 'Of one substance with the Father' (applied to Christ).

Consubstantia'tion (otherwise *Impanation*), the mystical union of the body of Christ with the sacramental elements, according to the Lutherans and others, who maintain that, after the consecration of the elements, the body and blood of Christ are substantially present with the substance of the bread and wine.

Consuetu'dinary Law, in contradistinction to statutory or written law, is that law which is derived by immemorial custom from remote antiquity. See *Common Law.*

Con'sul, a name originally given to the two highest magistrates in the republic of Rome. After King Tarquinius Superbus had been expelled by the joint efforts of the patricians and plebeians (509 B.C.), two consuls (*consules*) were placed at the head of the senate, the body in whose hands was the administration of the republic. These officers were annually elected, at first only from the patricians; at a later period (366 B.C.) also from the plebeians. In order to be eligible to the consulship, the candidate was to be forty-five years of age, and must have passed through the inferior offices of

quæstor, *ædile*, and *prætor*, and he was required by law to be in Rome at the time of the election. All these laws, however, were disregarded at various junctures in Roman history. The insignia of the consuls were a staff of ivory with an eagle at its head, a toga bordered with purple (*toga prætexta*), which under the emperors was embroidered; an ornamental chair (*sella curulis*), and twelve *lictors*, who, with *fascæ* and axes, preceded them. In the beginning of the republic the authority of the consuls was almost as great as that of the preceding kings. They could declare war, conclude peace, make alliances, and even order a citizen to be put to death; but their powers were gradually curtailed, especially by the establishment of the tribunes of the people, early in the 5th century. But they still stood at the head of the whole republic: all officers were under them, the tribunes of the people only excepted: they convoked the senate, proposed what they thought fit, and executed the laws. In times of emergency they received unlimited power, and could even sentence to death without trial, levy troops, and make war without the resolve of the people first obtained. Under the emperors the consular dignity sunk to a shadow, and became merely honorary. The last consul at Rome was Theodorus Paulinus (A.D. 536).

In France the name of *consul* was temporarily adopted for the chief magistrates after the revolution. The directorial government (third constitution) having been abolished by the revolution of the 18th Brumaire, of the year VIII (Nov. 9, 1799), a provisional consular government, consisting of Bonaparte, Siéyès, and Roger Ducos, established the fourth constitution, proclaimed Dec. 15, by which France was declared a republic under a government of *consuls*. Three elective consuls (Bonaparte, Cambacérès, Lebrun) had almost uncontrolled executive authority, while the legislative power was in the hands of the tribunate and the legislative assembly: a conservative senate was also elected. But as early as Aug. 2, 1802, Bonaparte was proclaimed First Consul for life, and thus the constitution of France became again practically monarchical. On April 10, 1804, he was proclaimed emperor, and even the nominal consulate ended.

At present *consuls* are officials appointed by the government of one country to attend to its commercial interests in seaports or other towns of another country. The duties

of a consul generally speaking are to promote the trade of the country he represents; to give advice and assistance when called upon to his fellow-subjects; to uphold their lawful interests and privileges if any attempt be made to injure them; to transmit reports of trade to his own government, to authenticate certain documents, &c. They are generally of three ranks: *consuls-general*, *consuls*, and *vice-consuls*.

Consumption, or PHTHISIS (Gr. *phthiō*, to consume), a disease known by emaciation, debility, cough, hectic fever, and purulent expectoration. The predisposing causes are very variable—hereditary taint, scrofulous diathesis, syphilis, small-pox, &c.; exposure to fumes and dusty air in certain trades; violent passions and excess of various kinds, sudden lowering of the temperature of the body, &c. The more immediate or occasional causes are pneumonic inflammation proceeding to suppuration, catarrh, asthma, and tubercles in the lungs, the last of which is by far the most general. The incipient symptoms usually vary with the cause of the disease; but when it arises from tubercles it is usually marked by a short dry cough that becomes habitual, but from which nothing is spit up for some time except a frothy mucus. The breathing is at the same time somewhat impeded, the body becomes gradually leaner, and great languor, with indolence, dejection, and loss of appetite prevail. At a later stage the cough becomes more troublesome, particularly by night, and is attended with an expectoration, the matter of which assumes a greenish colour and purulent appearance, being on many occasions streaked with blood. In some cases a more severe degree of blood-spitting attends, and the patient spits up a considerable quantity of florid, frothy blood. At a more advanced period of the disease a pain is sometimes felt on one side in so high a degree as to prevent the person from lying easily on that side; but it more frequently happens that it is felt only on making a full inspiration, or coughing. At the first commencement of the disease the pulse is often natural, but it afterwards becomes full, hard, and frequent. At the same time the face flushes, particularly after eating, the palms of the hands and soles of the feet are affected with burning heat; the respiration is difficult and laborious; evening exacerbations become obvious, and by degrees the fever assumes the hectic form with remittent exacerbations twice

every day, at noon and evening. From the first appearance of the hectic symptoms the urine is high coloured, and deposits a copious branny red sediment. At this time the patient is usually costive; but in the more advanced stages a diarrhoea often comes on, colliquative sweats likewise break out, and these alternate with each other, and induce great debility. Some days before death the extremities become cold. In some cases a delirium precedes that event. The morbid appearance most frequently to be met with on the dissection of those who die of phthisis is the existence of tubercles in the cellular substance of the lungs, most usually at the upper and back part; but, in some instances, occupying the outer part, and forming adhesions to the pleura. In some cases life has been protracted till not one-twentieth part of the lungs appeared, on dissection, fit for performing their function. The left lobe is oftener affected than the right. The diet in this disorder should be nutritious, but not heating, or difficult of digestion. Milk, especially that of the ass; farinaceous vegetables; acescent fruits; animal soups; and, above all, cod-liver oil, &c., are usually given. It is also of the utmost importance to see that the digestive organs are in proper working order. Removal to an equable climate or to a pure and mild air, may arrest the disease in its incipient stage. In Oct., 1890, Dr. Koch, of Berlin, gave to the medical world his theory of the treatment of tuberculosis by a new medicament which he styled lymph. Experiments following his idea are now being made in all prominent medical circles, with varying success.

Consumption, in political economy, all use or expenditure of the products of industry or of things having an exchangeable value. It is usually characterized as productive or unproductive, according as it does or does not conduce to the efficiency of a producer and to further production. Thus wealth in the form of machinery is consumed productively by wear and tear in the processes of production; and, similarly, wealth expended in improving land is productively consumed; but the wealth expended in the maintenance of an operative is, from the ordinary point of view, unproductively consumed. The classification, however, is not of a very definite kind, the distinction lying for the most part in the degree of directness and obviousness with which the act of consumption is related

to production. Hence in the case of the operative it is sometimes urged that the recreative benefit conferred upon the community tends indirectly to increase efficiency in production, and that from this point of view the operative consumes productively. So the expenditure of wealth in war, or in preparations for war, usually classed as unproductive, may be really productive consumption, as tending to the assurance of the producer in the stability of the commercial conditions. The perfect characterization of an act of consumption as productive or unproductive involves the consideration of elements of a frequently incommensurable kind, and the rough practical economic test has to be employed with some amount of reservation. Consumption is the end of all production; and as the demand of the consumer determines the employment of the various coefficients of production, land, labour and capital, it is urged by many later economists that the scientific treatment of economics should proceed from consumption to production, instead of from production to consumption in accordance with the method of the older economists. Too much stress may be laid upon this method, but the consideration of economic problems from the stand-point of the consumer is of advantage, as giving the social need, rather than the producer's profit, the prior claim upon the attention.

Contact Action. See *Catalysis*.

Contagion, the communication of disease by contact direct or indirect. A distinction has sometimes been made between *contagion*, as the communication of disease strictly by contact, and *infection*, as communication of disease by the miasmata, exhalations or germs which one body gives out and the other receives. There is little doubt that excessively minute disease germs proceed from the breath, the perspiration or other excretions of a diseased person, and are capable of propagating the disease in another person; but the true nature of these is little understood. *Antiseptics*, or *disinfectants*, are used to destroy the poisonous particles, such as carbolic acid, sulphur, permanganate of potash, chlorine gas, &c.

Contagious Diseases Acts, acts for the prevention of contagious venereal diseases communicated by women, and having force only at certain naval and military stations, passed in Britain in 1864 and 1866, and amended in 1868, 1869, and 1875. They provided for the compulsory examination of prostitutes residing in or near any of the said

stations, and for their detention in hospital if found to be affected with venereal disease. They were repealed in 1886.

Contagious Diseases (Animals) Act, an act of the British parliament passed in consequence of the ravages of the disease known as *Rinderpest* or cattle-plague, which broke out in 1865. Commissioners were appointed to investigate the subject, and in 1869 an act (subsequently amended by acts in 1878, 1884, and 1886) was passed enforcing regulations for preventing the introduction and spread of contagious diseases. The chief provisions are the appointment of veterinary inspectors, who have power, subject to confirmation by a local authority or Privy Council, to declare a place, with all lands and buildings contiguous, affected. The Privy Council may also declare a still wider extent of the surrounding district (by the act of 1886 the whole space lying within half a mile of the infected place) an infected *area*. The Privy Council is also empowered to make all arrangements respecting transit of infected cattle, and may order the slaughter of all animals affected with cattle-disease or pleuro-pneumonia and all animals that have been in same stable or shed with infected animals, and even all animals suspected of cattle-plague, and further all animals within the area declared infected. Provision is made for compensation to owners of slaughtered cattle. Power is also given to the Privy Council to issue general or special orders prohibiting the landing of animals or carcasses, fodder, &c., from a foreign country; to appoint ports at which alone foreign animals may be landed. The acts apply to all the three kingdoms, but there are some special administrative provisions regarding Scotland and Ireland.

Contan'go, in stock-jobbing, a sum of money paid to a seller for accommodating a buyer, by carrying the engagement to pay the price of shares bought over to the next account day. In reality contango is interest paid for the loan of money for fourteen days, that is for the interval between account days. See *Backwardation*.

Contari'ni, a noble family of Venice which furnished seven doges to the State, besides several men of note.

Contem'porary Review, THE, a British monthly magazine, founded January, 1866. It holds a foremost place amongst the more serious periodicals, and counts the most distinguished men of the day amongst its contributors.

Contempt', an offence against the dignity, order, or authority of a court or legislative assembly. Contempts committed out of court may be punished by fine or imprisonment, contempts done before court are usually punished in a summary way by commitment or fine. The power of vindicating their authority against contempt is incident to all superior courts.

Content and **Noncontent** are the words by which assent and dissent are expressed in the House of Lords. **AYE** and **No** are used in the House of Commons.

Con'tinent, a connected tract of land of great extent, forming a sort of whole by itself, as Europe, Asia, Africa, North and South America; or we may speak of the Eastern and Western continents, Europe, Asia, and Africa being regarded as one, and North and South America another. Australia, from its size, may also be regarded as a continent.

Continen'tal System, a plan devised by Napoleon to exclude Britain from all intercourse with the continent of Europe. It began with the decree of Berlin of November 21, 1806, by which the British Islands were declared to be in a state of blockade; all commerce, intercourse, and correspondence were prohibited; every Briton found in France, or a country occupied by French troops, was declared a prisoner of war; all property belonging to Britons, fair prize, and all trade in goods from Britain or British colonies entirely prohibited. Britain replied by orders in council prohibiting trade with French ports, and declaring all harbours of France and her allies subjected to the same restrictions as if they were closely blockaded. Further decrees on the part of France, of a still more stringent kind, declared all vessels of whatever flag, which had been searched by a British vessel or paid duty to Britain, denationalized, and directing the burning of all British goods, &c. These decrees caused great annoyance, and gave rise to much smuggling, till annulled at the fall of Napoleon, 1814.

Contin'gent, the name often given to the quota of troops which is to be furnished by each member of a number of states composing a confederation.

Continu'ity, LAW OF, an important principle in the investigation of the laws of motion and change in general. It may be enunciated thus: nothing passes from one state to another without passing through all the intermediate states.

Contornia'ti (It.), ancient medals or medallions in bronze, having a curved furrow (*contorno*) on each side, supposed to have been struck in the days of Constantine the Great and his successors, and to have formed tickets of admission to the public games of the circus of Rome and of Constantinople.

Contour (kon'tör), an outline. In geodesy *contours*, or *contour lines*, are lines or levels carried along the surface of a country or district at a uniform height above the sea-level, and then laid down on a map or plan, so that an approximately true outline of its contour is presented, the degree of accuracy depending on the number of lines or levels taken between the sea-level and the highest point in the region.

Con'trabad, in commerce, all goods and wares exported from or imported into any country, against the laws of said country. There are, also, a number of articles termed *contraband of war* which neutrals may be prevented, by one belligerent, from carrying to another. These generally include not only arms and munitions of war, but all the articles out of which they may be made. In recent times even provisions in certain cases have been considered contraband of war.

Contrabas'so, the Italian name, now usually employed by musicians of all nationalities to designate the largest instrument of the violin kind (called sometimes the *double bass*), with three strings usually tuned in fourths. Its compass is from the lower A of the bass clef to tenor F. In Germany a fourth string is used, which gives it a range of three notes lower.

Con'tract, in law, an agreement or covenant between two or more persons, in which each party binds himself to do or forbear some act, and each acquires a right to what the other promises. Contracts may be in express terms or implied from the acts of the parties; they may be verbal or written, and at common law both forms are binding; but by statute law a promise must be in writing. To be valid, a contract must be entered into by parties legally competent, that is, of sound mind and of full age. The act contracted for must not be contrary to law or public policy. Thus an agreement to do injury to another, or a contract not to marry at all (except in the case of a widow) is void. The contract must be founded on a consideration either of money or some act whereby an undoubted advantage accrues to the party sued. Lastly, the contract is

voidable, if obtained by fraud, mistake, or compulsion.

Contract, ORIGINAL or SOCIAL, in politics, that which is supposed to exist from the beginning between the sovereign power and the subject. Such a contract is evidently a mere supposition, having no historical foundation in any annals which have been preserved.

Contractil'ity, the power which certain tissues in animals and plants have, during life, of shortening themselves. It may be either voluntary or involuntary.

Contrac'tions, abbreviations employed with the view of saving labour in writing, and also in former times with the view of saving parchment in extending MS. copies of works, deeds, &c. Contraction takes place in several modes, as by elision; writing a smaller letter above the word contracted; running two or more letters into one character; by symbols representing syllables or words; by initial letters; thus: *recd.* for *received*; *q^m* for *quam*; *Mr.* for *Master*; *&* for *et*; *p* for *per*; *S.P.Q.R.* for *Senatus populusque Romanus*. When the contraction consists of the initial letter, syllable, or syllables of a word, as *ult.* for *ultimo*, it is more correctly termed an *abbreviation*. See *Abbreviations*.

Con'tral'to, in music, the highest voice of a male adult, or the lowest of a woman or a boy, called also the *Alto*, or when possessed by a man *Counter-tenor*. It is next below the treble and above the tenor, its easy range being from tenor G to treble C.

Con'trate-wheel, a wheel having the teeth projecting perpendicularly to the plane of the wheel.

Contravalla'tion, in fortification, a line formed in the same manner as the line of circumvallation, to defend the besiegers against the enterprises of the garrison.

Con'trayer'va, the aromatic bitterish root of *Dorstenia Contrajerva*, a plant of the nettle family, imported from tropical America, and used as a stimulant and tonic.

Control'ler, a public officer appointed to control, oversee, or verify the accounts of other officers.

Con'tumacy, in law, disobedience of the orders of a court; the offence of non-appearance when summoned judicially.

Co'nus, a genus of gasteropodous molluscs, the type of the family Conidæ or cone-shells, so named from the conical form of the shell. They are found in the southern and tropical seas.

Convales'cent Hospitals, hospitals intermediate between ordinary hospitals and the homes of the patients, established in order that those who have been successfully treated may be fully restored to health and strength before going back to their former insanitary surroundings.

Convalla'ria, a genus of plants, nat. order Liliaceæ, the only species being the lily-of-the-valley.

Convection of Heat, the transference of heat by means of the upward motions of the particles of a liquid or gas which is heated from beneath. See *Heat*.

Con'vent, a religious house inhabited by a society of monks or nuns. See *Monastery*.

Conven'ticle, a private assembly or meeting for the exercise of religion. Historically, the term was specially applied to meetings of petty sects and dissenters in the statutes of the time of Charles II.

Convention (Latin, *conventio*, a meeting), a formal or statutory assembly, particularly of delegates or representatives, for discussing civil or political matters. In Great Britain the name *Convention parliament* is given to the assembling of parliament without the king's writ; as in 1660, when Charles II. was restored, and in 1688, when the throne was left vacant by the flight of James II.—*Convention of Royal Burghs*, a yearly meeting held in Edinburgh by commissioners from the royal burghs of Scotland to discuss industrial regulations, &c.—*National Convention*, in French history, the name given to that body which met after the Legislative Assembly had pronounced the suspension of the royal functions (Sept. 1792), and proclaimed the republic at its first sitting.

Conversa'no, a town in South Italy, province of Bari, 18 miles S.E. of Bari, with a fine cathedral, and a trade in wine, oil, almonds, flax, and cotton. Pop. 9731.

Conversazione (-sat-si-ō'ne), a reception, usually on a large scale and in the evening, at which the company move about, converse with their acquaintances, partake of tea, coffee, or other refreshments, and often have objects of art, science, or general interest set out for their inspection.

Conversion, a term in logic. A proposition is *converted* when the predicate is put in the place of the subject, and the subject in place of the predicate; as, 'no A is B' ('no virtuous man is a rebel'), the converse of which is 'no B is A' ('no rebel is a virtuous man'). Simple conversion, however, in this manner is not always logical. In the

case of universal affirmatives, for example, 'all A are B' (say, 'all men are animals'), the simple converse 'all B are A' ('all animals are men') would not be true.

Con'vex (Latin *convexus*, vaulted, arched), rising in a circular or rounded form; the contrary to *concave*. Thus the inside of a watch-glass is concave, the outer surface convex.

Convex Lens. See *Lens*.

Convey'ancing, the practice of drawing deeds, leases, or other writings (*conveyances*) for transferring the title to property from one person to another, of investigating the title of the vendors and purchasers of property, and of framing those multifarious deeds and contracts which govern and define the rights and liabilities of families and individuals. The business of conveyancing is carried on by barristers, solicitors, and members of the legal profession generally.

Con'vict, in Britain the general term for a person who has been found guilty of a serious offence and sentenced to penal servitude, such servitude consisting usually in forced labour on some public work, as in the construction of a harbour, fortification, breakwater, or the like. Transportation was formerly the equivalent punishment.

Convic'tion, the finding a person guilty of an offence by the verdict of a jury. In certain cases of minor offences, such as are tried before justices of the peace, &c., the law allows of convictions without the intervention of a jury.

Convoca'tion, an assembly of the clergy of England, belonging either to the province of Canterbury or to that of York, to consult on ecclesiastical matters. From the fact that the province of Canterbury is by much the more influential of the two provinces into which England is ecclesiastically divided, the convocation of the province of Canterbury is often spoken of as *the* convocation, as if there were only one. In former times convocations had the power of enacting canons; but this power was virtually abolished by the statutes of Henry VIII. and Elizabeth.

Convolvula'ceæ, a natural order of plants comprising about 700 species largely consisting of climbers. Some of them have valuable properties. Jalap is derived from the *Exogonium purga*, an inhabitant of Mexico. See *Convolvulus*.

Convol'vulus, a genus of plants, type of the nat. order Convolvulaceæ, consisting of slender twining herbs with milky juice;

bell-shaped flowers and five free stamens. Some species are commonly known as bind-weeds (*C. arvensis*); others are cultivated in gardens. *C. tricolor*, or minor convolvulus, with its large flowers of violet blue, with white and yellow centre, is a familiar species. Scammony is obtained from the root of the *Convolvulus Scammonia*, a native of Syria; the liqueur *noyau* from *C. dissectus*. Some species, like the *C. Batatas*, or sweet-potato, have tuberous and fleshy roots capable of being used as food. *Convolvulus Jalapa* was long considered as yielding the true jalap of commerce. This is now known to be procured from *Ipomœa purga*, an allied plant, found in the mountainous regions of Mexico.

Con'voy, a fleet of merchantmen under the protection of a ship or ships of war, or the ship or ships appointed to conduct and defend them from attack and capture by an enemy. In military language it is used for *escort*.

Convul'sion, a diseased action of muscular fibres, known by violent and involuntary contractions of the muscular parts, with alternative relaxations. Convulsions are universal or partial, and have obtained different names according to the parts affected, or the symptoms. The muscles principally affected in all species of convulsions are those immediately under the direction of the will, as those of the eyelids, eye, face, jaws, neck, superior and inferior extremities. Convulsions are produced commonly by irritation of some part of the brain or spinal cord, such as the general convulsions in inflammation of the brain membranes, or of the nerves themselves. Children of a nervous temperament are often the subjects of convulsions during dentition, particularly when accompanied by a disordered state of the bowels or the presence of worms.

Convul'sionists, CONVULSIONARIES, those fanatics of the last century in France who had or affected to have convulsions, produced by religious impulses. The name was first applied to fanatics who exhibited varied seizures at the tomb of a Jansenist at St. Médard, some jumping, some barking, and others mewing like a cat. A number of them were imprisoned, but this had little effect.

Conway, or ABERCONWAY, a town and parliamentary borough of North Wales, in Carnarvonshire, about 13 miles E.N.E. of Bangor, at the mouth of the Conway. It is notable for its old castle built by Edward

I., a suspension bridge built by Telford, and a tubular railway bridge by Stephenson. Pop. 3179.—The river Conway has a course of about 30 miles through much romantic scenery.

Cony, CONEY, an old name for the rabbit; used also in the English version of the Bible as a translation of a Hebrew word probably meaning the *Hyrax syriacus*, a rabbit-like animal common in Syria and Palestine, inhabiting clefts of rocks. See *Hyrax*.

Cony'za, a genus of plants, nat. order Compositæ, annual or perennial herbs, scattered over the warmer regions of the earth, a few being found in temperate countries. None possess properties of any value. In England *C. squarrosa* is called *flcabane* because of its supposed property, when powdered and sprinkled, of driving away fleas.

Cooch-Behar', or KUCH-BEHAR', a native state in India, in political relation with the government of Bengal. It forms a level plain of triangular shape, intersected by numerous rivers, and is entirely surrounded by British territory. The greater portion of the soil is fertile and well-cultivated. Area, 1307 sq. miles; pop. 602,624.—The chief town, COOCH-BEHAR, contains some handsome public buildings and a splendid new palace of the Maharajah. Pop. 9535.

Cook, ELIZA, English poetess, born in London in 1818. She was early a contributor of the New Monthly Magazine, the Metropolitan, and the Literary Gazette; and in 1838 published a collection of poems under the title of *Melaia and other Poems*. Since then she has written a great many poems mostly of a lyric cast, and some of her songs have been highly popular. From 1849 to 1852 she carried on a weekly periodical, *Eliza Cook's Journal*; had a pension of £100 from the Civil List. Died in 1889.

Cook, JAMES, a famous British navigator, born in Yorkshire. 1728, of parents not above the rank of peasantry. He was at first apprenticed to a shopkeeper; but acquiring a love for the sea, he became a sailor. In 1755 he entered the royal navy, and four years later as sailing-master of the *Mercury* performed valuable services in surveying the St. Lawrence River and the coast of Newfoundland. Some observations on a solar eclipse, communicated to the Royal Society, brought him into notice, and he was appointed commander of a scientific expedition to the Pacific, with the rank of lieutenant in the navy. During this expedition he successively visited Tahiti, New

Zealand, discovered New South Wales, and returned by the Cape of Good Hope to Britain in 1771. In 1772 Captain Cook, now raised to the rank of a commander in



Captain Cook.

the navy, commanded a second expedition to the Pacific and Southern Oceans, which resulted like the former in many interesting observations and discoveries. He returned to Britain in 1774. Two years later he again set out on an expedition to ascertain the possibility of a north-west passage. On this voyage he explored the western coast of North America, and discovered the Sandwich Islands, on one of which, Hawaii, he was killed by the natives, February 14, 1779. Captain Cook wrote and published a complete account of his second voyage of discovery, and an unfinished one of the third voyage, afterwards completed and published by Captain James King.

Cookery, the preparation of food so as to render it more palatable and more digestible. The art is of great importance, not only for comfort but also for health. Food is mainly prepared by submitting it to the action of fire, as by roasting, boiling, stewing, &c. These processes give each a different flavour to food, but result alike in rendering the tissues, both of animal and vegetable food, softer and much more easily dealt with by the digestive organs. The art of cookery was carried to considerable perfection amongst

some of the ancient nations, as for instance the Egyptians, Persians, and Athenians. Extravagance and luxury at table were notable features of Roman life under the empire. Amongst moderns the Italians were the first to reach a high degree of art in this department. Their cooking, like that of the ancient Romans, is distinguished by a free use of oil. Italian cookery seems to have been transplanted by the princesses of the House of Medici to France, and was carried there to perhaps the highest degree of perfection; even yet the skill and resource which the French cook shows in dealing often with very slight materials is a highly creditable feature in the domestic economy of the nation. British cookery has been mostly confined to simple, strong, and substantial dishes. The art of roasting is perhaps its strong point. Of late, attempts have been made in London and other places to diffuse a knowledge of cookery more widely among the lower classes. In particular the *National School of Cookery*, headquarters at South Kensington, has sent forth lecturers and teachers to almost all the chief towns of Great Britain with the result of establishing local centres in many places.

Cook's Inlet, an inlet of the North Pacific Ocean, running into the Territory of Alaska for about 150 miles; explored by Captain Cook in 1778.

Cook's Islands, a name of the Hervey Islands, given to them because discovered by Captain Cook. See *Hervey Islands*.

Cook's Strait, the channel which separates the two principal islands of New Zealand, discovered by Captain Cook in 1770.

Cookstown, a town, Ireland, county Tyrone, 10 miles north of Dungannon; manufactures of linen and large trade in flax. Pop. 3870.

Coolers, WATER, vessels of porous, unglazed earthenware, in which a liquid can be kept cool by constantly exuding through the substance of the ware and evaporating from the outer surface of the vessel.

Coolie (Tamil, *kuli*), a name in Hindustan for a day labourer, also extended to those of some other eastern countries. Many of these have been introduced into the West Indies, Mauritius, and other places, their passage being paid for them on their agreeing to serve for a term of years. The first coolie emigrants appear to have been those sent to British Guiana from Calcutta in 1839 to supply the want of labour felt after

the abolition of slavery. The coolies employed in Guiana are still chiefly from India, but there is also a considerable number of Chinese. Coolies have also been introduced into Jamaica, Trinidad, Natal, and large numbers into Mauritius, the Indian population of the latter island being nearly 250,000. The Chinese coolies have been principally sent to Cuba and Peru. Quite distinct from this form of emigration is that of the Chinese who settle in Australia and America, and pay their own passage.

Cool-tankard, an old English beverage of various composition, but usually made of ale, with a little wine, or wine and water, with an addition of lemon juice, spices, and borage, or other savoury herbs.

Coom'assie, a town, West Africa, capital of Ashantee, 130 miles north of Cape Coast Castle. It was taken and burned by Sir Garnet Wolseley, at the head of the English expedition sent against the Ashantees in 1874. Pop. about 50,000.

Coombe, WILLIAM, born at Bristol in 1741, died in 1823, author of several popular works, including the *Diaboliad*; the *Devil upon Two Sticks* in England, a continuation and imitation of Le Sage's novel, but far inferior in spirit and graphic delineation to the original; the *Tour of Dr. Syntax in Search of the Picturesque*; the *History of Johnny Quæ Genus*; *English Dance of Death*, &c., all accompanied by Rowlandson's prints, to which they owe most of their value.

Coo'mie, a present in place of customs-duty, demanded by the kings and chiefs at parts of the West African coast for permission to trade with the natives.

Coomptah, a town of India on the sea-coast, in the presidency of Bombay, about 330 miles s.s.e. of Bombay. It has an open roadstead and a large cotton trade. Pop. 10,629.

Cooper, SIR ASTLEY PASTON, English surgeon, was born in Norfolkshire, 1768. He studied medicine in London, and attended the lectures of John Hunter. After visiting Paris in 1794 he was appointed professor of anatomy at Surgeon's Hall, and in 1800 head surgeon of Guy's Hospital. In 1822 appeared his great work on *Dislocations and Fractures*. Shortly after he became president of the Royal College of Surgeons, and honours and titles of every kind poured in on him. He died in 1841.

Cooper, JAMES FENIMORE, American novelist, born at Burlington, New Jersey, in 1789, studied at Yale College, and en-

tered the American navy as a midshipman at the age of sixteen. In 1821 appeared the novel of *Precaution*, the first production of his pen. Though successful it gave no scope for his peculiar powers, and it was not till the production of the *Spy* and the *Pioneers* that he began to take a high place amongst contemporary novelists. After that came a steady flow of novels dealing with life on the sea and in the backwoods, most of which, like the *Pilot*, *Red Rover*, *Waterwitch*, *Pathfinder*, *Deer-slayer*, and *Last of the Mohicans*, are familiar names to the novel-reading public. After visiting Europe and serving as Consul for the United States at Lyons for three years, Cooper returned to America, where he died at Cooperstown, New York, 1851. Besides his novels he wrote a history of the U.S. navy, and some volumes descriptive of his travels.

Cooper, PETER, American inventor, manufacturer, and philanthropist, born 1791, died 1883. He started life with few advantages, being almost self-educated; but by dint of energy, perseverance, sagacity and integrity, accumulated a large fortune. He carried on the manufacture of glue and isinglass for over fifty years, and was also connected with the iron-manufacture, the railways (he designed and built the first American locomotive), and the telegraphs of the U. States. The "Cooper Union" in New York was established by him to furnish a free education in art and practical science. It comprises day classes, in which women are instructed in drawing, painting, and other branches of art; evening classes, in which young men and women are taught art, engineering, chemistry, mathematics, &c.; free reading-room and library, &c.

Co-operative Societies are associations of individuals for mutual assistance in industrial or commercial objects. One form of co-operative societies is that of an association of men belonging to some trade or industry for the purpose of carrying it on entirely by their own efforts, and thus securing all the profits of their labours to themselves; but much more common associations are those the object of which is to provide the members, and sometimes also the general public, with the ordinary household necessities, at as near as possible the prime cost. Associations of the former kind are thus associations for production, those of the latter for distribution, by means of what are commonly known as *Co-operative Stores*. **Co-operative**

societies of the latter kind have been established very widely in Great Britain, one of the first and most successful of them being the Rochdale Equitable Pioneers' Society. This, like others, is conducted on the principle of dividing the surplus profits among the members alone in proportion to their purchases, after a certain fixed percentage has been deducted for interest on the capital subscribed. This society commenced in 1844 with only seventeen members; it has now 6000 or 7000, and sells goods annually to the value of more than £260,000. Like other such societies, it provides its customers with butcher-meat, all kinds of groceries, boots and shoes, drapery, &c.; and a part of the profits is devoted to educational purposes. A striking feature in connection with the societies in the North of England, where they are very numerous and flourishing, is the formation of an association of co-operative societies, The North of England Co-operative Wholesale Society, for the purpose of making their purchases on as large a scale as possible, so as to increase the profits. There are now in Great Britain about 1300 societies, with sales amounting to £30,000,000 a year. Similar associations have been formed for the benefit of other than the working-classes, such as clergymen, lawyers, medical practitioners, officers in the army and navy, members of the civil service, &c. The *Civil Service Supply Association of London* is the most extensive of these, and has been very successful, the annual sales amounting to about £1,700,000. Manufacturing associations of all kinds have been tried on the European continent, but neither there nor in Britain have they on the whole been very successful. In these societies, generally called Working Men's Associations, the shareholders are usually also the workmen, and the surplus profits are divided among them as workmen after they have received the fixed percentage as shareholders, and in some cases also amongst the workmen who are not shareholders, if there are any such. In Germany there are societies for the purchase of raw materials, manufacturing associations, societies of united shops, and co-operative stores. In the U. States co-operation has as yet chiefly taken the form of building-loan associations for providing the members with houses of their own. See also *Building Societies* and *Friendly Societies*.

Cooper's Creek, or the BARCOO, called by the latter name chiefly in its upper course,

the largest inland river of Australia, which rises in Queensland by two branches, the Thomson and Victoria (or Barcoo), and flows south-west to Lake Eyre.

Co-ordinates, in geometry, a term applied to lines, to which points under consideration are referred, and by means of which their position is determined. Co-ordinates either determine the position of a point in space or in a plane which is understood to contain all the figure under consideration. They determine position by straight lines only, or by a straight line and angles; in the latter case they are called *polar* co-ordinates. When co-ordinates are at right angles to each other they are called *rectangular* co-ordinates, and when they make any other angle with each other they are called *oblique* co-ordinates.

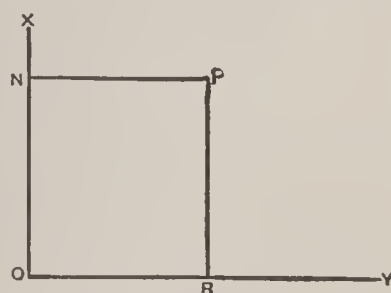

In the fig. OX OY are two fixed lines at right angles to each other, and P is a point whose position is to be determined. If we know ON and OR we can easily find the position of P , of which ON OR are called the co-ordinates.

Coorg, or KURG, an ancient principality now a province in Southern Hindustan, lying between Mysore on the east and north-east and the districts of South Canara and Malabar on the west; area, 1583 sq. miles. The country has a healthy climate, and yields coffee, spices, timber, &c. The capital is Merkara. Pop. 178,302.

Co'os. See *Cos*.

Coosy, a river of Northern Bengal, which rises among the Nepaul Himalayas, flows in a southerly direction, and falls into the Ganges after a course of 325 miles.

Coot, a grallatorial bird of the rail family (*Rallidæ*), frequenting lakes and ponds. The common coot (*Fulica atra*) has a bald forehead, a black body, and lobated toes, and is about 15 inches in length. The nests, which are very large, strong, and compact, are composed of reeds and rank water-herbage, built sometimes near the water's edge, and sometimes on small islets at some distance from the shore. Should the nest be set adrift by a rise of water, the female coot seems in nowise disturbed, but sits composedly on her eggs until it is stranded. The coot of India, China, and Japan is said

to be identical with that of Europe, but the North American coot is now recognized as a distinct species, and has received the name of *F. Wilsoni*.

Copaiba, COPAIVA (ko-pā'ba, ko-pā'va),



Copaiba Plant (*Copaiifera officinalis*).

the name of a balsam and an oil. The balsam is a liquid resinous juice flowing from incisions made in the stem of a plant, *Copaiifera officinalis* (nat. order Leguminosæ), and several other species of the genus, growing in Brazil, Peru, &c. It consists of several resins dissolved in a volatile oil. The resins are partly acid and partly neutral; the oil is clear, colourless, and has an aromatic odour. It is used in medicine, especially in affections of the mucous membranes (as those of the urino-genital organs).

Copais (ko-pā'is), a lake or marsh of Greece in Bœotia, inclosed by mountains on every side, and forming a shallow expansion of the river Cephissus some twenty miles broad, the water having numerous subterranean outlets to the sea. In 1881 a French company was formed for draining the lake or marsh, and thus redeeming some 62,000 acres of land. Operations were commenced in 1881, and the drainage works have since been carried on, the estimated cost being 10,000,000 francs.

Copal is a gum-resin yielded by different trees in Africa, South America, India, and Australia, and differing considerably in its qualities according to its origin; but in general it is hard, shining, transparent, and citron-coloured. When dissolved in alcohol or turpentine it makes a beautiful and very durable varnish. Indian copal, known in England as *gum animé*, is produced by *Vateria Indica*; Madagascar copal from *Hymenæa verrucōsa*; Brazilian copal from several species of *Hymenæa* and *Icica*, and from *Trachylobium martianum*. A substance called *fossil copal* or *copalin* is found in some places. It resembles copal resin in colour and odour.

Copalche Bark (kō-pal'chā), the bark of the *Strychnos pseudo-quina* (order Euphorbiaceæ), a native of Brazil. The name is also given to the bark of *Croton pseudo-china* (order Loganiaceæ) of Mexico. It resembles cascarilla bark in its properties.

Copan', a ruined city of Central America, Honduras, on the Copan River, with some remarkable remains.

Copar'cenary, in law, partnership in inheritance; joint heirship in which each is entitled to a distinct share of the benefits, while the property remains undivided.

Co-partnership. See *Partnership*.

Cope, a sacerdotal vestment, resembling a sleeveless cloak with a hood, reaching from the shoulders to the feet, worn on solemn occasions, and particularly in processions, by the pope and other bishops as well as by priests. It was one of the vestments retained at the Reformation in the Anglican Church.



Cope.

A, Probably Dr. Robert Langton, Queen's Coll. Oxon.
1, Cope.
B, Figure from Pugin's Glossary. 222, Cope.

Cope, CHARLES WEST, English painter, born 1811, studied at the Royal Academy and in Italy, and first exhibited at the academy in 1831. In 1843 he gained a prize of £300 for his picture 'The First Trial by Jury;' in 1844, by his fresco the 'Meeting of Jacob and Rachael,' secured the commission for one of six frescoes for the House of Lords, producing accordingly 'Edward the Black Prince receiving the Order of the Garter.' Altogether he has

executed eight frescoes from English history of the 17th century for the House of Lords, while his other works have been numerous, the subjects being historical, romantic, or domestic. We may mention 'Last Days of Cardinal Wolsey,' 'Prince Henry before Justice Gascoigne,' 'Departure of the Pilgrim Fathers,' 'Burial of Charles I.' 'Parting of Lord William and Lady Russell,' 'L'Allegro and Il Penseroso,' 'Milton's Dream,' 'Shylock and Jessica,' 'Ann Page and Slender,' 'Lear and Cordelia.' He became A.R.A. in 1844 and R.A. in 1848, but retired in 1883.

Cope, SIR JOHN, an English general whose name has become known chiefly through a Jacobite ballad celebrating the battle of Prestonpans, in which he was ignominiously defeated by Prince Charles Edward, on the morning of the 21st of Sept. 1745.

Co'peck (*kopeika*, a lance), a Russian copper coin, so called from the impression of St. George bearing a lance, the hundredth part of a silver rouble, or about the eightieth part of a paper rouble. It is equal to about three-eighths of an English penny.

Copenha'gen (Danish *Kjöbenhavn*, merchants' haven), the capital of Denmark, on the Sound, the larger and older portion of it on the east side of the Island of Zealand, a smaller portion on the north point of the island of Amager, with between them a branch of the sea forming the harbour. It has a citadel and several strong forts protecting it on the sea side; and is mostly well built, principally of brick. The chief buildings are the royal palace of Rosenborg, with many antiques and precious articles; the Amalienborg, consisting, properly speaking, of four palaces, one of them the usual residence of the sovereign; the palace of Charlottenburg, now the repository of the Academy of Arts; the Royal Library, containing 550,000 volumes and 25,000 manuscripts; Thorwaldsen's Museum, containing a great many of the sculptor's works; the university buildings; the Vor Frue Kirke; the arsenal; &c. The university, founded by Christian I. in 1478, has about 70 professors and teachers, five faculties, and a library of 200,000 volumes. The harbour is safe and commodious. Copenhagen is the principal station of the Danish fleet and the centre of the commerce of Denmark. It carries on an active trade with Norway, Sweden, Russia, and Germany, and in particular with Britain, the principal exports being grain, butter, cheese, beef, pork, cattle, horses, hides, &c. It has

foundries and machine-works, woollen and cotton mills, porcelain works, breweries, distilleries, &c., and produces also watches, clocks, pianofortes, &c. Sugar-refining and tanning are carried on. Copenhagen is first mentioned as a fishing hamlet in 1043. In 1443 it was made the capital of Denmark. It has occasionally suffered much from fires and from hostile attacks, the most disastrous being the bombardment by the British from the 2nd to the 5th of Sept. 1807. In 1801 the Danish fleet was here defeated by Sir Hyde Parker and Nelson. The environs in some parts are very fine. Pop. in 1880, 234,850, or including suburbs, 273,320; in 1886 with suburbs, 285,700; in 1890, 312,387.

Copep'oda, an order of minute entomostracous fresh-water and marine crustacea, so named because their five pairs of feet are mostly used for swimming (Gr. *kopē*, an oar).

Coper'nicus, or KOPPERNIGK, NICHOLAS, astronomer, born at Thorn, then in Poland, Feb. 19, 1473, his family being supposed to have come originally from Westphalia. Having studied medicine at Cracow, he afterwards devoted himself to mathematics and astronomy, and in 1500 taught mathematics at Rome with great success. Returning to his own country he was made a canon in the cathedral of Frauenburg, and began now to work out his new system of astronomy. Doubting that the motions of the heavenly bodies could be so confused and so complicated as the Ptolemaic system (which see) made them, he was induced to consider the simpler hypothesis that the sun was the centre round which the earth and the other planets revolve. Besides this fundamental truth Copernicus anticipated, for he can scarcely be said to have proved, many other of the principal facts of astronomical science, such as the motion of the earth round its axis, the immense distance of the stars which made their apparent position the same from any part of the earth's orbit, &c. His general theory also enabled him to explain for the first time many of the important phenomena of nature, such as the variations of the seasons and the precession of the equinoxes. The great work in which Copernicus explained his theory, *De Orbium cœlestium Revolutionibus* (On the Revolutions of the Celestial orbs), was completed in 1530, and published at Nuremberg in 1543. He was excommunicated by the pope on account of it. He died at Frauenburg 24th May, 1543.

Copiapó, a river, a town, and a seaport of Chili. The river flows west from the Andes

to the Pacific, and has a course of 120 miles. About 30 miles from the sea is the town of Copiapó, or San Francisco de la Selva, the centre of an important mining district. Pop. 27,531. The seaport, Porto Copiapó, stands at the mouth of the river, and has about 1200 inhabitants.

Co'ping, the top or upper covering of a wall made to project and slope so as to carry the rain-water clear of the wall.

Cop'ley, JOHN SINGLETON, a self-taught and distinguished painter, was born in 1737, in Boston, Massachusetts, and died in London in 1815, where he settled in 1776, and acquired a reputation as a historical painter. He was elected a member of the Royal Academy in 1779. His most celebrated picture is the Death of Lord Chatham, now in the National Gallery. His son became Lord Lyndhurst.

Cop'per, one of the most anciently known metals, deriving its name from *Cyprus*, large supplies having in Greek and Roman times come from that island. It is a metal of a pale red colour tinged with yellow; chemical symbol Cu, atomic weight 63.2. Next to gold, silver, and platinum it is the most ductile and malleable of metals; it is more elastic than any metal except steel, and the most sonorous of all except aluminium. Its conducting power for heat and electricity is inferior only to that of silver. It has a distinct odour and a nauseous metallic taste. It is not altered by water, but tarnishes by exposure to the air, and becomes covered with a green carbonate. It occurs native in branched pieces, dendritic, in thin plates, and rarely in regular crystals, in the primitive and older secondary rocks. Blocks of native copper have sometimes been got weighing many tons. Its ores are numerous and abundant. Of these several contain sulphur and iron or other metal, such as copper glance or vitreous copper (Cu_2S); gray copper or Fahlerz, one of the most abundant and important ores; and copper pyrites or yellow copper ore ($\text{Cu}_2\text{Fe}_2\text{S}_4$), another abundant ore. The red oxide of copper (Cu_2O) forms crystals of a fine red colour, and is used for colouring glass. There are two native carbonates, the blue and the green, the latter being the beautiful mineral *malachite*, the former also known as blue malachite. *Blue vitriol* is a sulphate, and is used for dyeing and preparing pigments, as are various other copper compounds. *Verdigris* is an acetate. The arsenite of copper is the pigment *Scheele's green*. *Schweinfurth*

green is another copper pigment. All the compounds of copper are poisonous. It is found in most European countries, in Australia and Japan, in Africa and in North and South America (especially in the vicinity of Lake Superior). In Britain the mines of Cornwall are the richest. Copper is extracted from its ores either by the dry or the wet process. For the former, what is known as the Welsh process is most common in Great Britain. It consists in alternately roasting the ore, and then smelting it in a furnace with a suitable slag, until impure or *blister copper* is obtained. Before this stage is reached a metallic compound of copper, sulphur, and iron has been produced, technically known as *matt*, *regulus*, or *coarse metal*, and subsequently a tolerably pure sulphide of copper called *fine metal*. The blister copper is refined by burning off the sulphur, arsenic, and other volatile impurities, and by melting it along with wood charcoal and stirring it with a wooden pole. The quality is then tested, and, if found satisfactory, the copper is cast into ingots. In extracting the metal from pyrites by the wet process, the ore is first roasted to get rid of the larger proportion of sulphur, then the calcined residue still containing sulphur is mixed with common salt, ground and heated in ovens. The copper is thus converted into chloride, part of which volatilizes, but is condensed, along with arsenic and other substances, by passage through flues and water-condensers. After some hours the calcined mixture is raked out of the ovens, cooled, and transferred to tanks, where it is exhausted by successive treatment with water. The solution, containing chloride of copper, sulphate and chloride of sodium, and iron salts, is next heated along with scrap-iron. Copper precipitates in the form of a ruddy, lustrous, tolerably compact mass, with a crystalline appearance, and mixed with metallic-iron and oxide. The larger pieces of iron are picked out, the precipitate washed and drained, and then rendered compact by heating in a furnace. A slag containing the oxide of iron forms, and the copper, when judged sufficiently pure, is run into moulds. Afterwards this crude metal is refined and toughened in the usual way, and the slags are employed as in the Welsh process. Some of the alloys of copper, especially those containing tin and zinc, are of considerable importance, *e. g.*, *bronze*, an alloy of copper with about 8 or 10 per cent of tin; *bell-metal* composed of eighty parts

of copper and twenty of tin; British bronze coinage, copper 95, tin 4, zinc 1. Copper is applied to a great many useful purposes. In sheets it is used for sheathing the bottoms of ships, covering roofs and domes, the constructing of boilers and stills of a large size, &c. It is also used in electrotyping and engraving, for various household utensils and fittings; but its use for household utensils is by no means free from danger on account of the action of acids on it, which produces verdigris.

Cop'peras, sulphate of iron or green vitriol ($\text{FeSO}_4 \cdot 7\text{H}_2\text{O}$), a salt of a peculiar astringent taste and of a fine green colour. When exposed to the air it assumes a brownish hue. It is much used in dyeing black and in making ink, and in medicine as a tonic. The copperas of commerce is usually made by the decomposition of iron pyrites.

Copper-fastened, said of a ship when the bolts and other metal-work in her bottom are made of copper and not iron.

Copper Glance (Cu_2S), a copper ore of a lead or iron-gray colour. It consists of 81 copper and 19 sulphur, and abounds in Cornwall and many European countries.

Copper-head, a venomous N. American serpent, the *Trigonocephalus contortrix* of the rattlesnake family.

Cop'pering, sheathing a ship's bottom with thin sheets of copper, to prevent the ship-worm eating into the planks, or to keep shells and weeds from accumulating on the surface, and so retarding a vessel in her sailing.

Cop'permine River, a river, British North America, which falls, after a course of about 250 miles, into the Arctic Ocean, in lat. 68° N.; long. 116° W.

Copper-nickel, or KUPFERNICKEL, an ore of nickel, an alloy of nickel and arsenic, containing about 60 of the former and 40 of the latter, of a copper colour, found in the mines of Westphalia.

Copper-plate, a polished plate of copper on which the lines of some drawing or design are engraved or etched to be printed from; also a print or impression from such a plate.

Copper Pyri'tes, or yellow copper ore, a double sulphide of copper and iron composed in equal parts of copper, sulphur, and iron. It occurs mostly in primary and metamorphic rocks, and is the chief copper ore of England.

Cop'pice, or COPSE WOOD, a wood in which the trees are cut over periodically as

they attain a certain size. In Britain many forest trees, and in particular the oak, the chestnut, the ash, the birch, and the maple, are dealt with in this way. The period for cutting varies with the soil and the tree. The oak usually requires from fifteen to twenty-five years' growth, while the willow is cut regularly every year. The term is also used in a general sense for a wood of small growth, or consisting of underwood and brushwood.

Cop'ra, the dried kernel of the cocoa-nut, from which the oil has not yet been expressed, a considerable article of commerce in some tropical regions.

Cop'rolites, the term originally applied to the fossil excrements of extinct animals, chiefly lizards or sauroid fishes. They resemble oblong pebbles, and are found mostly in the Lias and Coal Measures. They consist chiefly of phosphates of calcium and magnesium, and the carbonates of the same metals, and organic matter, and as the fertilizing properties of these are well-known, coprolites have been largely used as a manure. For this purpose they are reduced to powder and used as ground bones, or treated with sulphuric acid, so as to form superphosphate of lime.

Copse. See *Coppice*.

Cop'tis, a small genus of plants, nat. order Ranunculaceæ, two species of which, *C. trifolia* (gold-thread), found in Canada and the northern parts of the United States, and *C. tecta* of Assam, yield a bitter tonic used medicinally.

Copts, a name given to the Christian descendants of the Ancient Egyptian race, belonging mostly to the Jacobite or Monophysite sect. Reduced by a long course of oppression and misrule to a state of degradation, the number and national character of the Copts have greatly declined. At present they do not amount to more than perhaps 350,000. Their costume resembles that of the Moslems, but they are very generally in the habit of wearing a black turban for distinction's sake. In various other respects they resemble the Moslem, and they practise circumcision and abhor the flesh of swine. The women go out with veiled faces like the Moslem women. There are schools for the male children, but very few of the females are taught to read. Confession is required of all. Fasting holds a prominent place in the life of the Copt, who is, indeed, required to fast (that is, to abstain from all animal food except fish) during

the greater part of every year. The head of the Coptic Church is the Patriarch of Alexandria, who is also head of the Abyssinian Church. He is regarded as the successor of St. Mark, by whom the Copts believe that Christianity was introduced among them. They are very strict and exclusive in their religion, but a certain number have latterly been converted to Protestantism. The Copts are quiet and industrious, have a good capacity for business, but are said to be servile and crafty. The Coptic scribes form a close guild. What is called the *Coptic language* is no longer spoken, Arabic having taken its place. It is still used, however, in a formal way in their religious services. It is regarded as the direct descendant of the ancient sacred language of the Egyptians. There is a tolerably abundant Coptic Christian literature, chiefly lives of saints, homilies, &c. It is written in what is substantially the Greek alphabet, with some additional letters.

Copy, a writing, picture, &c., made in direct imitation of another. Of late years photography has been much used in copying paintings, engravings, maps, &c. Lithography is frequently used in multiplying copies of writings, such as circulars, and such contrivances as the gelatine pad and the papyrograph are also in common use. A copy of a work of art made by the artist himself is called a *replica* or *doublette*, and a reproduction of a piece of sculpture in plaster a *cast*.

Copyhold, in English law, a tenure of land by copy from the court rolls belonging to a manor. Copyhold property cannot be now created, for the foundation on which it rests is, that the property has been possessed time out of mind, by copy of court roll, and that the tenements are within the manor. In 1858 parliament passed a law which enables either the lord or tenant of any copyhold lands to compel enfranchisement of the land and convert it into freehold, either in consideration of a fixed sum or of an annual rent.

Copyright, denotes the property which an author has in his literary works, or which any other person has acquired by purchase, and which consists of the exclusive right of publication; or the right which a designer, engraver, painter, draughtsman, photographer, or sculptor has in his designs, engravings, paintings, &c. The act of 5 and 6 Vict. cap. xlv. (Talfourd's act), passed in 1842, is now the law which regulates literary property throughout the British dominions. This law gives the copyright of

a work exclusively to the author for the whole term of his life, and to his heirs for seven years after his death. But if the author should die within forty-two years of the publication of his work, then the copyright continues to his heirs till the whole period of forty-two years from the publication of the work has expired, if it does not expire until at least seven years after his death. In the case of encyclopædias, reviews, magazines, and other periodical works, the copyright is vested in the proprietors as if they were the authors; but after twenty-eight years the copyright of all articles claimed by the authors reverts to them for the period of fourteen years still to elapse under the terms of this act. It is, of course, quite competent to the authors of such articles to reserve the right of publishing them in a separate form. A register of books published under the act is kept at Stationers' Hall. Five libraries have a right to a copy of every book published in the kingdom, viz.: the library of the British Museum, the Bodleian, the Public Library at Cambridge, the Faculty of Advocates' Library at Edinburgh, and that of Trinity College, Dublin. Dramatic and musical compositions are subject to the same copyright as books. The exclusive right of performing dramatic and musical compositions not printed, or of causing them to be performed, belongs to the author or his assignees under the same rules of copyright as those relating to books. Paintings, drawings, and photographs are secured in a right of reproduction for the term of the author's life and seven years after his death; engravings, lithographs, and prints taken by other mechanical processes are protected for twenty-eight years. Copyright in sculptures, models, or casts, extends for fourteen years when duly registered. The right in designs for articles of manufacture is granted for various periods from nine months to three years according to the class of manufacture. Lectures and public speeches are the property of the author and cannot be published without his consent, unless they are lectures delivered on any public endowment or foundation. Letters are the property of the writer, and the receiver has no right of publishing it without the writer's consent. Any person pirating a copyright work is liable to a special action, and all copies of pirated works become the property of the proprietor of the copyright. In European countries copyright is generally for

the author's life, and a varying period thereafter—twenty, thirty, or even fifty years.

As to Canadian copyright, an author domiciled in Canada, or in any part of the British possessions, or being citizen of a state having an international copyright treaty with Great Britain, may secure copyright in Canada for twenty-eight years and renewal of it for fourteen years to himself or to his widow and children, but to no one else who may be in possession of the copyright. In the U. States as in Britain copyright extends not only to books but to dramatic compositions, maps, engravings, &c. American copyright is now extended to citizens or subjects of every nation which grants copyright to citizens of the U. S. on the same terms as to its own citizens. The term for which copyright is granted is twenty-eight years, with renewal to the author himself or his widow and children for other fourteen.

A copyright may exist in a translation or in part of a work (as in notes or additional matter), with an exclusive right to the whole; but a *bona fide* abridgment of a book is not considered in Britain and America a violation of the original copyright. So a person may use fair quotation if by its application he makes it a part of his own work, but cannot take the whole or a large part of a work under the pretence of quotation.

International copyright is when nations make mutual arrangements as to copyright. By British acts passed in 1844, 1852, and 1875, the copyright of works published in foreign countries was secured to the authors and their assigns within the British dominions, on complying with certain regulations, the benefit of this act being extended only to countries according a similar protection to British authors. France, Prussia, Italy, Belgium, and other powers concurred at different times in this system of reciprocal copyright; but the subject of international copyright has not as yet been considered settled on a satisfactory footing, and various attempts at a better settlement have been made. In Sept. 1885 an international conference met at Berne, and articles of an International Copyright Union were signed by the representatives of the various powers (Britain, France, Germany, Italy, Belgium, Spain, Switzerland, &c.) in the following year, the main principle of the scheme being that each state should accord to the subjects of the other states the same advantages as it accords its

own. To enable this convention to be carried into effect in the British dominions an act was passed in 1886. An author in a foreign country to which an order in Council under this act applies has, under certain conditions, the right of translation for a period not exceeding ten years. Works first produced in the colonies are protected under this act; as regards the admission of foreign reprints of British works into the colonies, however, no adequate provision has as yet been made.

In March, 1891, the U. S. Congress passed an International Copyright Act. By its terms the entire manufacturing of foreign copyrighted works must be performed in the United States.

Coquette Bark (ko-ke't'a), the name of a bark, from *Cinchona lancifolia*, which contains quinine in it.

Coquilla-nut (ko-kwil'la), the seed of the piassava or piçaba palm (*Attalëa funifëra*), one of the cocoa-nut group, a native of Brazil. The nuts are 3 or 4 inches long, oval, of a rich brown colour and very hard, and are used in turnery for making umbrella-handles, &c.

Coquimbo (ko-kim'bō), or LA SERENA, a town of Chili, capital of the province of Coquimbo, stands near the sea, on a river of the same name. It is the see of a bishop. Pop. 13,000. — PORTO COQUIMBO, the port of the above, from which it is distant 7 miles to the s.w., has smelting works and a large export trade, chiefly in copper and the precious metals. Pop. 5100.—The province is rich in copper, silver, gold, and other metals, and is mountainous. Pop. 165,474.

Coquito (kō-kē'tō), the *Juba a spectabilis*, a very beautiful palm of Chili, allied to the cocoa-nut, growing to the height of 40 or 50 feet, yielding a rich sweet sap, which when boiled is called palm-honey.

Corac'idæ. See *Rollers*.

Cor'acle, a small boat or canoe of oval form and made of wicker-work covered with skins. It was used by the ancient Britons, and something similar is still in use amongst Welsh fishermen and on the Irish lakes.

Cor'acid Bone, a bone in birds joining the sternum and shoulder-bone, and giving support to the wing. In mammals it is represented by the *coracoid process* of the scapula.

Cor'al, the name applied to the calcareous stony structures secreted by many of the *Actinozoa* (sea-anemones, &c.) which form

CORAL — CORALLINE.

one of the divisions of the cœlenterate zoophytes, and also applied to the animals themselves. Two kinds of corals are distinguished by naturalists, *sclerodermic* and *sclerobasic*, or those in which the calcareous skeleton is developed in the walls of the body, as in the reef-building corals, and those in which (as in the red coral of commerce) the skeleton is external or cuticular. Reproduction takes place by ova, but chiefly by budding, the new individual remaining in organic union with the old. The coral

masses grow not merely by the multiplication of individuals, but by the increase in height of each of the latter, which, as they grow, become divided transversely by partitions. The animal, distended with ova, col-

lapses on their discharge, and thus becomes too small for the cup which it formerly occupied; it cuts off the waste space by a horizontal layer of coral, and the repetition of this process gradually adds to the height of the mass. It is in this way that the coral reefs and islands, occurring in such abundance in the Pacific, the Indian Ocean, and the Red Sea, are built up—works of such stupendous and astonishing bulk when compared with the tiny creatures that produce them.

These coral reefs appear under three principal types, namely, the *fringing* reef, the *barrier* reef, and *atoll* or *lagoon* reef. According to Darwin's theory the latter two are merely developments of the first. The fringing reef on the margin, say, of a South Sea island (see *a* in the fig.) is the work of corals living near the shore. This island is supposed gradually to subside into the sea, but so slowly as to allow the coral polyps, which cannot exist at a greater depth than between 20 and 30 fathoms from the surface, to add to the height of the reef and keep themselves always at the same level. Thus, in the course of time, as the island sinks in the constantly receding margin, the coral formation will no longer be a fringing reef, but will stand out at sea, with water on all sides betwixt it and the island. In this

way the barrier reef is formed (as in *b*). But should the island continue to sink till it disappear altogether, the reef is then left as a huge circle inclosing a lagoon and constituting the atoll (*c*). By accretions of various kind this finally rises above the surface of the sea, is taken possession of by a tropical vegetation, and at length becomes the habitation of man. Darwin's theory is by many not considered satisfactory, however, and the formation of the coral reefs is explained without the theory of subsidence.

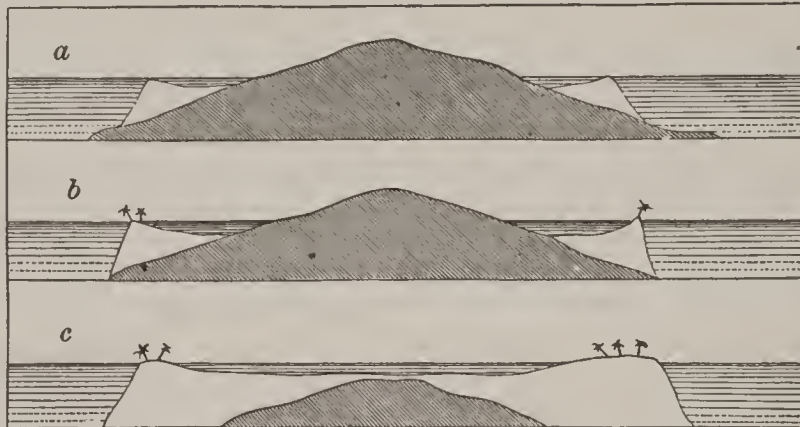

Formation of Coral Reefs, according to Darwin.

The coral of commerce is the production of various polyps, and is of different colours and internal structure. The red, pink, and black sorts are the most highly prized. The red coral has a branching shrub-like

form, and, as well as other sorts, is found abundantly in the Mediterranean. The coral fishery, as it is called, is carried on in various parts of the Mediterranean, the principal localities being the south-west coast of Corsica, where the finest quality is found, the coast of South Italy, and the north coast of Africa (Algeria and Tunis). The raw coral is wrought chiefly in Leghorn, Genoa, and Naples. The coral is brought up from the bottom by means of net-work bags with wide meshes, attached to cross-beams of wood that are let down from a vessel by a line. Italy takes the leading part both in fishing for coral and in its preparation for the market. Coral is capable of taking a good polish, but is not susceptible of receiving the finer execution of a gem. In composition it consists chiefly of carbonate of lime.

Coral Fishes, a name given to several fishes of different genera, belonging to the *Chatodontidæ*. They are found in all tropical seas, especially about coral reefs, and are all brilliantly coloured. The most important is the *Holocanthus imperator*, the 'emperor of Japan,' which measures about 15 inches in length, and is the most esteemed of all the Indo-Pacific fishes.

Cor'alline, a term popularly applied both to sea-weed with rigid calcareous fronds and to many of the zoophytes.

Coralline, an orange red colour, prepared by the action of ammonia at about 300° Fahr. upon rosolic acid, or upon the washed residue of the action of a mixture of sulphuric, oxalic, and carbolic acids. It is used for dyeing silk, and is also printed upon cotton.

Coral Rag, in geology, the highest member of the middle Oolitic series—a variety of limestone containing an abundance of petrified corals, occurring in some parts of England.

Coral Root. See *Dentaria*.

Coral Sea, part of the Pacific on the north-east of Australia, between it and the Solomon Islands and the New Hebrides.

Coral-tree, the name of leguminous trees and shrubs of the genus *Erythrina*, natives of Africa and America, with trifoliolate leaves and beautiful scarlet spikes of papilionaceous flowers.

Coranach. See *Coronach*.

Cor Anglais (kor-än-glā; French, 'English horn'), a wind instrument of the reed kind, similar to the oboe, and possessing a compass of like extent but of lower pitch. Its compass is from F fourth line in the bass, to B flat above the treble staff.

Cor'ato, a town of S. Italy; prov. Bari. Pop. 30,552.

Corbeil (kor-bāy), a town of France, dep. Seine-et-Oise, where the Essenne enters the Seine; various manufactures. Pop. 6392.

Cor'bel, in architecture, a piece of stone, wood, or iron projecting from the vertical face of a wall, to support some superincumbent mass. Corbels are of a great variety of forms, and are ornamented in many ways. They



Corbel, Castor Church, Northamptonshire.



Corbel-table.

are sometimes used in rows to support a projecting course called a *corbel-table*.

Corbie Steps, in architecture, steps into which the sides of gables from the eaves to the apex are broken. They are common in

old Scotch architecture, into which they were probably introduced from France.

Cor'chorus, the genus of plants to which jute belongs, order Tiliaceæ (the lime-tree). They are herbs or small shrubs with serrated leaves and small yellow flowers. See *Jute*.

Corcoran, WM. WILSON, banker, born in Georgetown, D. C., Dec. 27, 1798. Engaged in the banking business, accumulating a large fortune. Retiring from business in 1854 plans of benevolence engaged him till his death in 1889. His charities are estimated to exceed \$5,000,000. He founded the Corcoran Art Gallery at Washington.

Corday D'Armans (kor-dā-där-män), MARIE ANNE CHARLOTTE, commonly called Charlotte Corday, was born in Normandy in 1768, of a family which counted the poet Corneille amongst its ancestors. Her lover, an officer in the garrison of Caen, was accused by Marat as a conspirator against the republic, and assassinated by villains hired for that purpose. This, as well as a deep-rooted hatred against all oppressors, determined Charlotte Corday to free her country from Marat. Having obtained an interview with Marat at his own house she plunged her dagger into his bosom, and gave herself up to the attendants who rushed in at his cries. When tried for the murder before the revolutionary tribunals, her air was dignified and her replies firm. In spite of the fervid eloquence of her advocate's defence she was condemned to the guillotine, and was executed on 17th July, 1793.

Cordeliers (kor'de-lērz), originally an order of Franciscan monks who wore as part of their dress a girdle of knotted cords; afterwards the name given to a society of Jacobins, to which the names of Marat, Danton, and Camille Desmoulins gave some reputation. The club lasted from 1792 to 1794, and took its name from their place of meeting.

Cord-grass, *Spartina stricta*, a British grass, very tough, and used for making ropes.

Cor'diceps, a genus of fungi, some of which are found on dead leaves and branches, while others are remarkable for growing on the larvæ of insects, which they latterly kill.

Cordilleras (kor-dil-yā'rāz), a Spanish name given to the great chains of the Andes and of Mexico.

Cor'don, in a military sense, troops so disposed as to preserve an uninterrupted line of communication, to preserve an area either

CORDOVA — COREA.

from hostile invasion or from contagious diseases. In the latter sense it is called a *cordon sanitaire*.

Cor'dova, an ancient Spanish city on the Guadalquivir, in Andalusia, capital of a province of the same name. A part of the town is of Roman, a part of Moorish origin; the streets are narrow, crooked, and dirty; the principal square, however, is distinguished for its size and the beauty of its

colonnade. The cathedral is a splendid building, originally a mosque, erected in the 8th century by King Abderahman. The town is well supplied with schools, hospitals, and other institutions. It has always carried on considerable trade; and under the Moors the leather exclusively manufactured there (cordovan) was exported in all directions. Cordova, which was founded by the Romans, became the capital of Arabian Spain and the

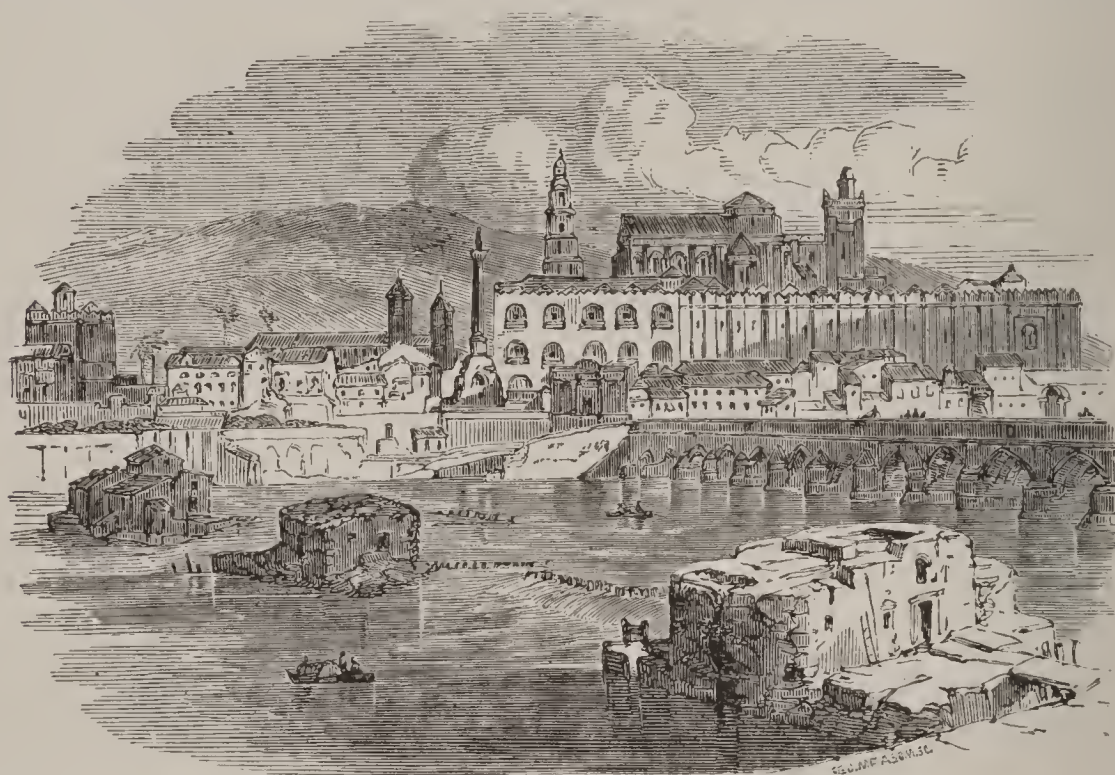

Cordova.

centre of Arabian splendour and science under the caliphs of the West. At this time it is said to have had a pop. of 1,000,000. With the decay of the Moorish empire it fell into the hands of Ferdinand III. of Castile. Pop. 55,614.—The province includes the fertile and beautiful valley of the Guadalquivir and the mountains of Sierra Morena. Area, 5188 square miles; pop. 420,714.

Cor'dova, a town of the Argentine Republic, capital of province of same name. It occupies a beautiful and well-sheltered site in the valley of the Primero, and has railways to Rosario and Tucuman. Pop. 66,000.—The province has an area of 54,000 sq. miles, and a pop. of 380,000.

Cor'dovan, a fine leather which took its name from the city of Cordova, where it was manufactured in large quantities. Much is now made in Northern Africa and the Levant.

Corduoy', a thick cotton stuff corded or ribbed on the surface.—*Corduoy road*, in

North America, a road constructed with logs laid together over swamps or marshy places for carriages to pass over.

Cord-wood, wood cut and piled for sale by the cord, in distinction from long wood; properly, wood cut to the length of 4 feet; but in this respect the practice is not uniform.

Core'a, a kingdom of Asia, consisting chiefly of a peninsula lying north-east of China, bounded N. by Manchuria, E. by the Sea of Japan, S. by a narrow sea which parts it from the Japanese Islands, and W. by the Yellow Sea. It is called by the natives Tsiotsien, and by the Japanese Korai, whence its European name. Pop. vaguely estimated at about 9,000,000 or more; area about 80,000 square miles. Söul or Seoul, is the capital. The peninsula is traversed through its length by a mountain range, abrupt and precipitous on the east, but forming a gentle slope on the west side, which, being watered by the principal rivers

COREGONUS — CORFU.

of the country, is exceedingly fertile. In the north the only grain that can be grown is barley; but in the south, wheat, cotton, rice, millet, and hemp are grown extensively. The ginseng root is a production greatly valued in China and Japan. The domestic animals are oxen, pigs, goats, dogs, and cats, and a small race of horses. Oxen only are used for agricultural labours, the horse being reserved expressly for the saddle. Tigers, panthers, foxes, wolves, and snakes are abundant. The manufactures are, generally speaking, rude, and mostly confined to tissues of hemp and cotton, silk, paper, and pottery. The peninsula abounds in minerals, gold, silver, iron, copper, lead, and coal, and the natives show much artistic skill in the art of working metals. Corea is governed by a king, who, on June 30, 1894, declared himself independent of China

America separating British and Dutch Guiana. It has a course of 300 miles, and is navigable 150 miles.

Corfe Castle, an English castle in Dorsetshire, now in ruins, standing a little north of a small town, to which it gives its name, and with which it is connected by a bridge of four arches. It was built by King Edgar, and at its gate his son Edward the Martyr was murdered in 979.



and appealed for protection to Japan. As a result war was declared between Japan and China in July, 1894. Buddhism, Confucianism, and Taouism are the chief religions. The Korean language is quite distinct from Chinese, but the educated classes use the Chinese system of writing. The Coreans resemble the Japanese more than the Chinese. Three ports have recently been opened for trade; the exports and imports together in 1891 amounted to \$8,622,612. The telegraph, electric light, &c., are now being introduced.

Cor'fu (anciently *Corcy'ra*), a Greek island in the Mediterranean, the most northerly of the Ionian Islands, at the mouth of the Adriatic, near the coast of Albania, about 40 miles long, and from 15 to 20 wide; square miles, 427. The surface rises at one point to the height of 3000 feet, the scenery is beautiful, the climate pleasant and healthy, the soil fertile. Oranges, citrons, grapes, honey, wax, oil, and salt are abundant. A Corinthian colony settled in the island in the 8th century B.C. The Venetians possessed Corfu from 1386 to 1797, the British from 1815 to 1864. Pop. 106,109.—CORFU, the capital, is finely situated on a promontory, which terminates in a huge insulated rock, crowned by the citadel; the streets are Italian in style; chief edifices, the cathedral, government palace, and Ionian academy. There is a good harbour and considerable trade. Pop. 25,139.

Coreg'onus. See *Vendace*.

Corelli, ARCANGELO, Italian musician, born 1653, died 1713. By his sonatas for the violin, and by his concerti, he may be considered, as it were, the creator of a new species of harmony, especially for his own instrument, the violin.

Corentyn (kor'en-tin), a river of S.

Corian'der (*Coriandrum sativum*), an umbelliferous plant, native of Italy, and cultivated in other parts of Europe. The whole plant has an unpleasant smell, but the fruit, improperly called seed, is very agreeable and aromatic when dry. It is used as a carminative and aromatic in medicine, and as an ingredient in cookery and confectionery.

Coria'ria, a genus of plants, type of a small natural order of polypetalous exogens. *Coriaria myrtifolia* is a shrub inhabiting the south of Europe and employed by dyers for staining black, and also used in tanning, and hence called *tanner's sumach*.

Corigliano (ko-rēl-yē-ā'nō), a town of S. Italy, province of Cosenza, on a hill above the right bank of the Corigliano, near the site of the ancient Sybaris, of which no vestiges remain. Pop. 13,272.

Corin'ga, a seaport in Hindustan, in the Godavari District, Presidency of Madras. It had once a great trade. Pop. 4397.

Corin'na, an ancient Greek poetess of Tanagra, in Bœotia, contemporary with Pindar (about 500 B.C.), whom she is said to have conquered five times at musical contests. Only a few fragments of her songs have come down to us.

Cor'inth, a once celebrated city upon the isthmus of the same name, which unites Peloponnesus with Northern Greece. It was renowned among the cities of Greece, commanded by its advantageous position a most important transit trade, and possessed all the splendour which wealth and luxury could create; while its citadel, the Acrocorinthus, nearly 2000 feet high, rendered it a strong fortress. Only a few ruins remain to attest its ancient magnificence. It had two harbours, Lechaëum on the west side of the isthmus, on what is now the Gulf of Corinth or Lepanto, and Cenchræ, on the Gulf of Athens or Ægina (anc. *Saronic Gulf*). Near Corinth were held the Isthmian games. Besides being one of the most magnificent, it was also one of the most voluptuous cities of Greece. After many political vicissitudes Corinth became the head of the Achæan League, and was conquered and destroyed by the Roman consul Mummius, 146 B.C. Julius Cæsar, about a hundred years later, rebuilt it; but its commerce could not be restored, though it became a place of note and importance. St. Paul lived here a year and a half, and two of his epistles are addressed to the Corinthians (see below).—*New Corinth* is a village on the shore of the gulf,

several miles N.W. from the site of ancient Corinth; it is the seat of an archbishop. Pop. 3000.

Corinth, GULF OF, or GULF OF LEPANTO, a beautiful inlet of the Mediterranean, about 80 miles long, between the Peloponnesus and Northern Greece, having the Isthmus of Corinth closing it in on the east.

Corinth, ISTHMUS OF, the isthmus which connects the Morea (Peloponnesus) with Northern Greece, varying in width from 4 to 8 miles. A canal, begun in 1882 and about 4 miles long, is in course of construction across the isthmus, and will enable vessels to sail from the Archipelago to the Adriatic without rounding Cape Matapan.

Corinthian Order, that order of Grecian architecture of which the most characteristic feature is the capital of the column, which is adorned with beautifully carved acanthus leaves, but varies considerably in minor details. The column is generally fluted, with a fillet between the flutings, and stands upon a base. The entablature is variously decorated, especially the cornice; the frieze may be quite plain, or sculptured with foliage and animals. The Corinthian order was not very common in Greece before the time of Alexander the Great; among the Romans it was much employed.

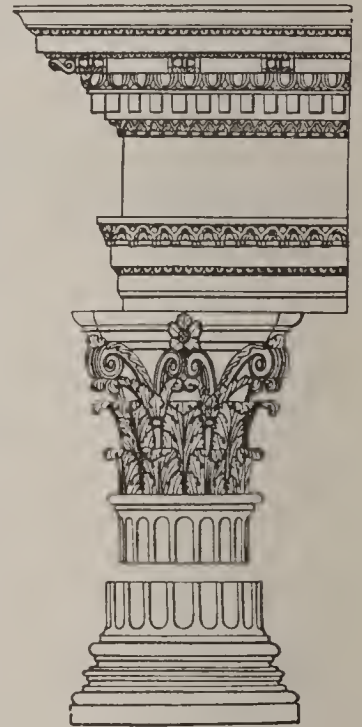

Corinthian Order.

the time of Alexander the Great; among the Romans it was much employed.

Corinthians, EPISTLES TO THE, two epistles addressed to the church at Corinth about A.D. 57 or 58, which have been admitted as genuine writings of St. Paul by even the most critical assailants of the New Testament canon. They are most instructive from the insight which they furnish into the character of St. Paul himself, and the constitution, parties, and heresies of the apostolic church.

Coriola'nus, the name given to an ancient Roman, Caius, or more properly Cneius, Marcius, because the city of Coriöli, the capital of the kingdom of the Volsci, was

taken almost solely by his exertions. He was banished for seeking to deprive the plebeians of their hard-earned privileges, and in particular of the tribuneship; and seeking revenge, he took refuge amongst the Volsci, the bitterest enemies of Rome, and prevailed upon them to go to war with her. The Volscian army, after making itself master of the cities of Latium, was pitched in sight of Rome before troops could be raised for the defence. The Roman senate made unavailing overtures for peace, till at length the tears of Veturia his mother, and Volturnia his wife, when they appeared at the head of the Roman matrons, induced Coriolanus to withdraw his army from before Rome. He was afterwards assassinated in a tumult while attempting to justify his conduct. The story of Coriolanus, which is now regarded as legendary, forms the subject of one of Shakspeare's plays.

Cork, a city in the south of Ireland, capital of the county of Cork, situated on the river Lee. It is 15 miles from the sea, and besides an upper harbour at the city itself, and quays extending over four miles in length, there is a lower harbour at Queenstown, 11 miles below the town. The entrance, deep and narrow, is strongly fortified on each side. Cork is the third city in Ireland, and exports great quantities of grain, butter, bacon, hams, eggs, and live stock. The principal industries are tanning, distilling, brewing, and the making of tweeds and friezes. There are also iron-foundries and yards for the building of iron ships. The principal buildings are the Protestant and R. Catholic cathedrals, exchange, custom-house, chamber of commerce, court-house, Queen's College, &c. There is a naval dockyard at Haulbowline, an island within Cork harbour. Cork sends two members to parliament. Pop. municipal bor. 80,124; parl. bor. 104,496.—The COUNTY is the most southerly and the largest in Ireland, having an area of 2885 square miles, or 1,849,686 acres, of which less than a fourth is under crops. The west part is mountainous, the north and east very fertile. The coast is indented with numerous bays and inlets, of which the more important are Bantry Bay, Kinsale and Cork harbours. The climate is remarkably mild, though moist. The county is watered by the Bandon, Lee, and Blackwater. Cattle, sheep, pigs, and quantities of butter are exported. The fisheries are important. The county has seven political divisions, each sending a

member to parliament. The county town is Cork; other towns are Queenstown, Fermoy, Youghal, Bandon, Mallow, and Kinsale. Pop. 1891, 436,641.

Cork is the external bark of a species of oak (*Quercus suber*) which grows in Spain, Portugal, and other southern parts of Europe and in the north of Africa, and is distinguished by the great thickness and sponginess of its bark, and by the leaves being evergreen, oblong, somewhat oval, downy underneath, and waved. The outer bark falls off of itself if left alone, but for commercial purposes it is stripped off when judged sufficiently matured, this being when the tree has reached the age of from fifteen to thirty years. The first stripping yields the coarsest kind of bark. In the course of eight or nine years, or even less, the same tree will yield another supply of cork of better quality, and the removal of this outer bark is said to be beneficial, the trees thus stripped reaching the age of 150 years or more. The bark is removed by a kind of axe, parallel cuts being carried round the tree transversely and united by others in a longitudinal direction, so as to produce oblong sheets of bark. These vary in thickness between $\frac{3}{4}$ inch and 3 inches. Care must be taken not to cut into the inner bark, or the tree would be killed. The pieces of cork are flattened out by heat or by weights, and are slightly charred on the surface to close the pores. Cork is light, elastic, impervious to water, and by pressure can be greatly reduced in bulk, returning again to its original size. These qualities render it peculiarly serviceable for the stopping of vessels of different kinds, for floats, buoys, swimming-belts or jackets, artificial limbs, &c. Corks for bottles are cut either by hand or by means of a machine. The best corks are cut across the grain.

Cork, EARL OF. See *Boyle*.

Cork, FOSSIL, a kind of mineral, a species of asbestos.

Corking-pin, a pin of a large size, formerly used for fixing a lady's head-dress.

Corleo'ne, a town, Sicily, 22 miles south of Palermo. Pop. 16,304.

Corliss, GEO. HENRY, inventor, was born in Easton, N. Y., June 2, 1817. The construction of stationary steam-engines has been revolutionized by his improvements. He has invented many ingenious devices. A single engine made by him moved all the machinery in the Centennial Exhibition of 1876. He died in 1888.

Cor'morant (from French, *cormoran*, L. *corvus marinus*, a sea-crow), the name of several large web-footed birds of the pelican family, or forming a family by themselves. They have a longish and strongly-hooked



Common Cormorant (*Phalacrocorax carbo*).

bill, long neck, short wings, and rather long rounded tail; all the toes are united by a web, and, though excellent swimmers, they are able to perch on trees; colour generally black or dark. The common cormorant of Europe (*Phalacrocorax carbo*) is larger than a goose, but with smaller wings. It occupies cliffs by the sea, feeds on fish, and is extremely voracious. It dives and swims with great power, and pursues its prey beneath the surface of the water, often to a great depth. Amongst the Chinese cormorants have long been trained to fish for man. At first a ring is placed on the lower part of the bird's neck to prevent it swallowing the prey, and in time it learns to deliver the fish to its master without such a precaution being necessary. Another British cormorant is the green cormorant or shag (*P. graculus*). It is smaller than the common cormorant. Both these species are found also on the eastern coasts of America, and there are various other American as well as Australian species.

Cormus. See *Corm*.

Corn (Fr. *corne*, L. *cornu*, a horn), a hardened portion of the cuticle of the foot, appearing as a sort of distinct growth, produced by pressure. Corns are generally found on the outside of the toes, but sometimes between them, on the sides of the foot, or even on the ball. They appear at first as small dark points in the hardened skin, and in this state stimulants or escharotics, as nitrate of silver (lunar caustic), are recommended. Perhaps the most effi-

acious remedy for corns is the application of glacial acetic acid night and morning.

Corn is the generic term for all kinds of grain used for making bread, and is applied specifically to the principal bread-stuff: in England to wheat, in the United States generally to maize, and frequently in Scotland to oats.

Corn, INDIAN. See *Maize*.

Corna'ceæ, a natural order of polypetalous exogens, consisting of about 100 species, two of which are found in Britain, *Cornus suecica*, a lowly alpine plant, and *C. sanguinea*, the common dogwood or prickwood. Several plants of this order are of service as tonics and for the cure of ague, and in America the bark of the *Cornus florida* is sometimes used as a substitute for Peruvian bark. See also *Cornel*.

Corn Aphides, aphides infesting the ears of corn, barley, oats, and other grain, and sucking their juices, as the *Aphis granaria*, or wheat aphid. See *Aphides*.

Corn-beetle, the *Cucujus testaceus*, a minute beetle, the larva of which is often very destructive to stores of grain, particularly of wheat, in granaries.

Cornbrash, a local name in England for a rubbly limestone, forming a soil extensively cultivated in Wiltshire for the growth of corn. The term is used by geologists to indicate the strata which yield the soil, the highest member of the lower Oolite.

Corn-cockle, a well-known weed (*Agrostemma Githago*), nat. order Caryophyllaceæ, with large entire purple flowers, very troublesome amongst crops of grain. Its seeds are said to be poisonous to geese, ducks, swine, &c.

Corn-crake, or LANDRAIL (*Crex pratensis*), is a species of bird of the order Grallæ or Waders, and of the family Rallidæ or rails. The crakes differ from the rails proper (*Rallus*) in having the bill shorter. The common crake of Britain is of a reddish-brown colour. It lives in fields and meadows, and nestles and runs among the long grass. The name is expressive of its cry. It feeds on worms and insects. It is a bird of passage, frequenting the northern parts of Europe during summer, and the southern, including the Mediterranean coasts of Africa, in winter.

Cor'nea, one of the coats of the eye, a transparent membrane in the forepart of it. See *Eye*.

Corneille (kor-nā-yè), PIERRE, the father of French tragedy and classic comedy, was

born at Rouen in 1606, at which place his father was advocate-general. He began his dramatic career with comedy, and a series of vigorous dramas, *Mélite* (1629), *Clitandre*, *La Veuve*, *La Suivante*, &c., announced the advent of a dramatist of a high order. In 1635 he entered the field of tragedy with *Medea*; but it was not till the appearance of his next work, the famous *Cid*, that Corneille's claim was recognized to a place amongst the great tragic poets. The *Cid* was an imitation of a Spanish drama, and though gravely defective in the improbabilities of the plot and other respects, achieved an immense success for a certain sublimity of sentiment and loftiness of ideal, which are the native characteristics of Corneille's poetry. After the *Cid* appeared in rapid succession *Horace* (1639); *Cinna* (1639), his masterpiece, according to Voltaire; and *Polyeucte* (1640), works which show Corneille's genius at its best. Many of his later pieces exhibit a marked decline. Besides his dramas he wrote some elegies, sonnets, epistles, &c., as well as three prose essays on dramatic poetry. As a dramatist his merits are loftiness of sentiment and conception, admirably expressed in a bold and heroic style of versification and language. But in this constant straining after a heroic ideal he was apt to fall into a declamatory and inflated style. He died in 1684.

Corneille, THOMAS, brother of the preceding, was born at Rouen in 1625. They had married two sisters, and lived in the same house in the utmost harmony. Thomas began with comedies, which were imitations of the Spanish school, and were received with even greater applause than those of his brother. The first was *Les Engagements du Hasard* (1647). His best tragedy is *Ariane* (1672). He is a dramatist of very secondary rank, laborious and cultivated, but wanting in original power. He died in 1709.

Cornel, or CORNELIAN TREE (*Cornus masculina*), a species of dogwood, a tree or shrub of the order Cornaceæ, distinguished by the hardness of its wood, a native of Asia and the south of Europe, cultivated as an ornamental plant in Britain. One of the finest, the round-leaved Cornel, *C. circinata*, is a large shrub, 5 to 10 ft. high, common from Virginia to Canada.

Corne'lia, daughter of Scipio Africanus the elder, married Tiberius Sempronius Gracchus, censor B.C. 169, by whom she was the mother of the two tribunes Tiberius and Caius Gracchus.

Corne'lian, or CARNELIAN, a gem of a light-red or flesh colour. It consists of silica along with minute quantities of the oxides of iron, aluminium, and sometimes of other metals, and is used for seals, bracelets, necklaces, and other articles.

Corne'lius, PETER VON, German painter, born at Düsseldorf in 1787, died in 1867. He early exhibited a taste for art, and studied the great masters, especially Raphael. In 1811 he went to Rome, where, in conjunction with Overbeck, Veit, and other associates, he may be said to have founded a new school of German art, and revived fresco-painting in imitation of Michael Angelo and Raphael. He left Rome in 1819 for Düsseldorf, where he had been appointed director of the academy, but he soon settled in Munich to give his whole attention to the painting of the Glyptothek and the Ludwigskirche there. In these two great works he was assisted by his Munich pupils. In 1833 he made another visit to Rome, and in 1839 he visited Paris. In 1841 he was invited to Berlin by Frederick William IV., who intrusted him with the painting of the royal mausoleum or Campo Santo. The most celebrated cartoon in this series is the Four Riders of the Apocalypse. The series consists of twelve paintings, which have been engraved. Cornelius, a true representative of modern German thought, introduced into art a metaphysical and subjective element which is easily liable to be abused; and in his work grandeur of conception and elevation of tone have to make up for the want of the finest natural effects.

Corne'lius Nepos, a Roman author of the 1st century B.C., the contemporary of Cicero and Catullus. The only extant work attributed to him is a collection of short biographies, probably an abridgment of a work written by Nepos. These biographies have long been a favourite school-book, and popular editions of them are very numerous.

Cornell University, at Ithaca in the state of New York, was established in 1867 with funds furnished from the income of 990,000 acres of public land allotted by congress to the state for this purpose and with a foundation of 500,000 dollars presented by the Hon. Ezra Cornell, much augmented by subsequent donations. There are five general courses, including classics, literature and philosophy, science, engineering, architecture, agriculture, &c. Women are admitted on the same terms as men.

Cornet, a wind-instrument of former times, originally curvilinear or serpentine in form and increasing in diameter from the mouth-piece to the lower end. The modern *cornet-à-pistons*, or *cornopeau*, is a kind of keyed bugle which has a very agreeable tone, and is much used in orchestras and military bands. Several forms of it are in use.

Cornet, formerly the lowest rank of commissioned officer in a regiment of cavalry in the British army, corresponding with the rank of ensign in the infantry. In 1871 this rank was abolished, that of sub-lieutenant taking its place.

Corne'to, a cathedral town of Italy, prov. Rome, on a lofty and precipitous volcanic ridge, 10 miles north of Civita Vecchia. Its old walls and its palaces and other edifices present a picturesque appearance. The ancient Tarquinii stood about a mile from Corneto; from the tombs in its necropolis a vast variety of Etruscan relics have been obtained. Pop. 6175.

Corn-fly, a name common to several insects of the family Muscidæ, from the injury their larvæ inflict on growing crops.

Corn-husking, CORN-SHUCKING, an assemblage of friends and neighbours at the house of an American farmer to assist him in stripping the husks or shucks from his Indian corn.

Corning, Steuben co., N. Y., a fine town on the Susquehanna river; joins Knoxville and Centreville on the opposite bank of the river by a bridge; has two National Banks. Pop. 8553.

Cornish Diamond, a variety of quartz found in Cornwall and employed even in the 16th century for personal ornaments. This variety being now scarce, ordinary rock-crystal is often used instead.

Cornish Engine, a single-acting steam-engine used for pumping water. The pump-rods, appended to one end of the beam, are loaded so as by their gravity to have sufficient force to raise the water, and the down-stroke of the steam piston at the other end of the beam is used to raise them.

Cornish Language, a Celtic dialect spoken in Cornwall, which died out in the last century, though isolated words or terms are still in use, and some fragments of literature are still extant. It is allied to the Welsh and Breton. See *Celts*.

Corn-laws, a name commonly given to certain statutes passed to protect the agricultural interest in Britain. The first form of interference by legislative enactment with the corn-trade in England, beginning soon after the Conquest, was the prohibition of exportation, an expedient in those times to prevent scarcity in a sudden emergency. The exportation of grain was prohibited in the reign of Edward III. in 1360-61, Calais and other appointed ports being excepted. This provision was relaxed by a statute of Richard II. in 1394, by which exportation was permitted from all ports not excepted by royal proclamation. In 1436, under Henry VI., the exportation of grain was permitted without license whenever the price of wheat did not exceed 6s. 8d. per quarter, and barley 3s. 4d. In 1463 a statute of Edward IV. prohibited importation until the price exceeded the limit at which exportation was permitted. This was the beginning of protection, properly so called. At the restoration of Charles II. duties were imposed both on exportation and importation, while the old principle of a standard price, beyond which exportation was prohibited, was retained. At the Revolution a new policy still more favourable to the agricultural interest was adopted. By act 1 William and Mary, cap xii., a bounty was granted on the exportation of corn, and the duties on exportation were abolished. The amount of the bounty was 5s. for every quarter of wheat exported while the price was at or under 48s., with corresponding prices for other grains. The exportation of grain reached its highest point about 1750. From this period the country, which had always been normally a grain-exporting country, began, on account of the increase of population and expansion of mechanical industries, to fall off in this respect, and in 1778 became permanently a grain-importing country. From this time the main efforts of the agricultural interest, largely represented in the parliament and the ruling classes of the kingdom, were concentrated on obtaining the imposition of prohibitory duties on foreign grain. In 1804, for instance, if the price of corn was below 63s. a prohibitory duty of 24s. 3d. was laid on what was im-

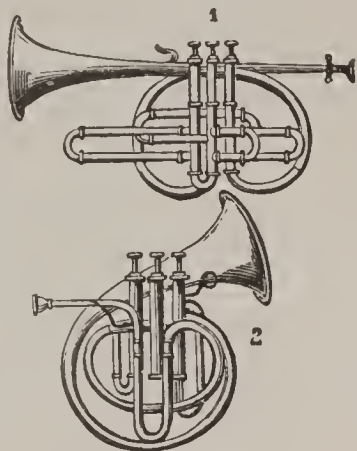

Cornet-à-Pistons.

1, Ordinary shape. 2, Circular shape.

ported; if between 63s. and 66s., a duty of 2s. 6d.; and only when the price at home had risen as high as 66s. per quarter was the foreign grain allowed to pass at a nominal duty of 6d. With variations of more or less importance this sliding-scale of prohibitory duties continued in force till 1846, when Sir Robert Peel, influenced by the corn-law repeal agitation, and more especially by the Anti-Corn-law League, headed by Cobden and Bright, carried a measure repealing the duty on imported corn, except a nominal sum of 1s. per quarter, which also in 1869 was done away with, thus leaving the importation of corn entirely free.

Corn Marigold (*Chrysanthemum segetum*), a common weed in British corn-fields, of a rich orange colour.

Corn-moth, a small moth, the *Tineā grannela*, the larva of which is exceedingly destructive to corn sheaves in the field, and to stored grain, from eating into the grains. Salt, frequent turning, and many expedients are employed to destroy the eggs.

Corno, MONTE. See *Gran Sasso*.

Corn Salad, *Valerianella olitoria* and other species of the same genus, order Valerianaceæ, is extremely easy of cultivation, and can be obtained in the very first days of spring. *V. olitoria*, called also lamb's-lettuce, is a weak, succulent herb 6 to 12 inches high, used as a salad in early spring.

Corn Saw-fly (*Cephus pygmaeus*), an insect the larvæ of which prey upon the wheat and other cereals. The female deposits her eggs in the stalk, where the larvæ live upon the interior of the straw and the nutritive juices of the plant.

Corn-thrips, a minute species of thrips, the *Thrips cerealium*, which does much mischief to grain crops, insinuating itself between the chaff and the unripe seed, and causing the latter to shrivel by sucking the juice. It is barely a line long.

Cornu Copiæ ('horn of plenty'), a wreathed horn filled to overflowing with fruit, flowers, and grain; used as the symbol of plenty. Also written *Cornucopia*.

Cornus, a genus of plants, nat. order Cornaceæ (which see).

Corn'wall, a maritime county of England, forming the south-western extremity of the island, bounded E. by Devonshire, and surrounded on all other sides by the sea; area, 1350 sq. miles or 863,665 acres. The coast-line is much broken. Mounts Bay, Falmouth Bay and Harbour, Whitsand Bay,

Fowey Harbour, and Plymouth Sound are the principal openings on the south coast. The indentations on the north consist of shallow bays with few or no harbours. Between these two coasts is the promontory of Land's End, terminating in granite cliffs about 60 feet high. Some of the other cliffs exceed 400 ft. in height. At Land's End terminate the hills of the Devonian Range. The part of this range belonging to Cornwall stretches from N.E. to S.W., forming the principal watershed of the county. Its highest summit is Brown Willy, 1368 ft. Granite and old red sandstone are the chief rocks. The rivers are numerous but short. Much of the area, especially in the elevated districts, is barren moorland. About a fifth is under the plough. The chief wealth of the county is in its minerals, especially its mines of copper and tin, though the value of both has diminished. Several mines exceed 350 fathoms in depth. In the Botalack Copper Mine, a few miles north of Land's End, the workings are carried below the sea. Besides tin and copper, silver, lead, zinc, iron, manganese, antimony, cobalt, and bismuth are found in comparatively small quantities. There are also valuable deposits of kaolin or china-clay. There are no manufactures, but the fisheries, particularly of pilchard and mackerel, are valuable. Cornwall, with the Scilly Isles, seems to have been the Cassiterides or Tin Islands of antiquity. The natives long maintained their independence against the Saxons, and their country was spoken of as West Wales. Their language also long continued to be Celtic. (See *Cornish Language*.) The chief towns are Bodmin (county town), Penzance, Truro, and Falmouth (with Penryn). Cornwall has six political divisions each sending a member to parliament. It gives the title Duke of Cornwall to the eldest son of the sovereign of Great Britain, and forms a royal duchy, the revenues of which belong to the Prince of Wales for the time being. The dukedom was created for the Black Prince in 1337. Pop. 1891, 322,589.

Cornwall, a port and manufacturing town of Canada, prov. Ontario, on the north side of the St. Lawrence, 67 miles above Montreal. Pop. 1891, 6805.

Corn'wallis, CHARLES, MARQUIS OF, son of the first Earl Cornwallis, born in 1738. Educated at Eton and Cambridge, he served in 1761 as an aide-de-camp in the Seven Years' war; was made colonel of foot in 1766, and finally general. On the outbreak

of the American war he sailed with his regiment, served with distinction under Howe and Clinton, and in 1780 was left in independent command in South Carolina with 1000 men. He defeated Gen. Gates



Lord Cornwallis.

at Camden, 1780, and fought Gen. Greene at Guilford in 1781, but six months afterwards was besieged in Yorktown and compelled to surrender 17th Oct., 1781. This disaster proved decisive of the war. In 1786 Lord Cornwallis went out to India with the double appointment of commander-in-chief and governor-general, invaded Mysore in 1791, and obliged Tippoo Saib to surrender much territory. Having returned to Britain he was created a marquis (1794), appointed Lord-lieutenant of Ireland, and again in 1805 Governor-general of India. He died the following year.

Corn-weevil, a destructive insect which preys upon stored corn. There are various species: order Coleoptera, family Curculionidæ, genus *Calandra*. The *Calandra granaria* is a slender beetle of a dark-chestnut colour about one-eighth of an inch long. It bores a hole and deposits its egg inside of the grain, which is afterwards eaten to a husk by the grub.

Coro, a seaport town, Venezuela, at one time a flourishing place but now much decayed. Pop. 8000.

Cor'ocore, a boat of the Indian Archipelago of various forms. That used in Celebes is propelled by oars, and is often manned with sixty men. Others, as those used in the Moluccas, are masted vessels.

Cor'ody, CORR'ODY, an allowance of meat, drink, or clothing, anciently due to the king from an abbey or other religious house, for the sustenance of such of his servants as he thought good to place there for maintenance. Corodies were also retained by the private founders of religious houses and even granted to benefactors, and consisted in the right of sending a certain number of persons to be boarded at an abbey.

Corol'la, in botany, the portion of the flower inside the calyx; the inner floral envelope. The corolla surrounds the parts of fructification and is composed of leaves called petals. When there are several free leaves it is called a *poly-petalous* corolla, as in the rose; but when the petals are united by the margins into a continuous structure it is called *monopetalous*, or more correctly *gamopetalous*. It may generally be distinguished from the calyx by the fineness of its texture and the gayness of its colours; but there are many exceptions.



aa, Many petaled or leaved Corollas. bb, Single petaled or leaved Corollas.

Cor'ollary (in Latin *corollarium*), in mathematics, a collateral conclusion, following from a proposition demonstrated.

Corolliflo'ræ, one of the great subdivisions of exogenous plants, distinguished by the corolla being gamopetalous, inserted below the ovary, and by the stamens being inserted on the corolla. The primrose, heath, gentian, verbena, &c., are included in this division.

Coroman'del Coast (*Cholomandala*), the east coast of the Indian Peninsula, Madras Presidency, or that portion of it between Palk's Strait and the river Pennar. It is open, sandy, and has no secure harbours, and the surf renders landing difficult and often impossible except to the native catamaran.

Coromandel Wood, the wood of *Diospyros hirsuta*, a tree found in Ceylon. Its ground colour is chocolate brown, with black stripes and marks; it is hard, turns well, and makes very handsome furniture.

Coro'na (L. 'a crown').—(1) In astronomy, a halo or luminous circle round one

of the heavenly bodies; specifically the portion of the aureola observed during total eclipses of the sun, which lies outside the chromosphere or region of coloured prominences. (2) In botany, an appendage of the corolla in some flowers, coming as it were between the corolla and the stamens, well seen in the cup of the daffodil. (3) In architecture, the lower member of the projecting part of a cornice.

Coro'na Australis (the 'southern crown'), one of Ptolemy's southern constellations, containing twelve stars.

Coro'na Borea'lis (the 'northern crown'), one of Ptolemy's northern constellations, containing twenty-one stars.

Cor'onach, or CORANACH, a dirge or lamentation for the dead formerly customary amongst the Celts of Scotland and Ireland.

Corona'tion, the placing of the crown on a monarch's head with solemn rites and ceremonies. Part of the ceremony usually consists in the oath which the monarch takes, that he will govern justly, will always consult the real welfare of his people, and will conscientiously observe the fundamental laws of the state. In England kings have been anointed and crowned in Westminster Abbey, even to the latest times, with great splendour. The form of the *coronation oath* is that settled after the revolution of 1688. The Archbishop of Canterbury puts it to the sovereign, who swears to govern according to the statutes of parliament, to cause law and justice in mercy to be executed, and to maintain the Protestant religion.

Coronel'idæ, a widely-spread family of non-venomous serpents. It includes several genera, as *Psammophylax* and *Coronella*. *Coronella levis*, the smooth snake, is a native of Britain.

Cor'oner, an official in England whose chief duty is to inquire into the cause of the death of persons killed or dying suddenly. There are usually four or six coroners appointed for each county, and in every borough having separate quarter-sessions a coroner must be appointed having exclusive jurisdiction within the borough. His examination is made in all cases with the aid of a jury, in sight of the body, and at the place where the death happened. If the body is not found he cannot sit. When the jury have brought in their verdict the coroner is to report to the next assizes or to the Queen's Bench. In the U. States coroners are elected or appointed. They have no defined responsi-

bility, except in cases of crime, where they can cause arrests.

Cor'onet, such a variety of crown as is worn by princes and noblemen. The coronet of a British duke is adorned with

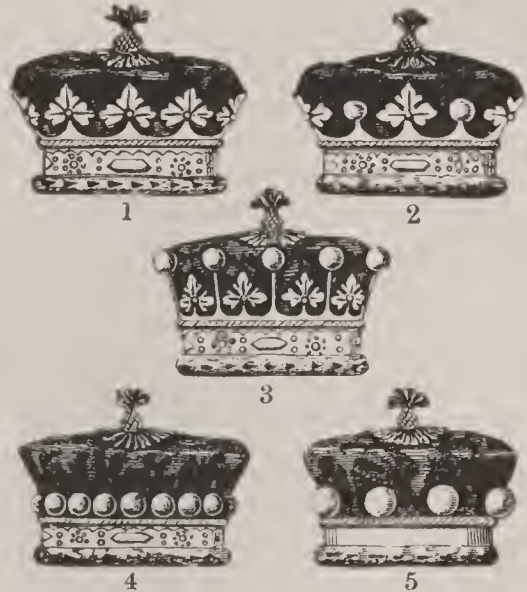

1, Coronet of a Duke. 2, Do. of a Marquis. 3, Do. of an Earl. 4, Do. of a Viscount. 5, Do. of a Baron.

strawberry leaves; that of a marquis has leaves with pearls interposed; that of an earl raises the pearls above the leaves; that of a viscount is surrounded with pearls only; that of a baron has only six pearls.

Corot (kō-rō), JEAN-BAPTISTE-CAMILLE, French artist, born at Paris in 1796; studied under Michallon and Victor Bertin and afterwards in Italy. He exhibited for the first time in the Salon in 1827, but some years elapsed before the high qualities of his work were recognized. The fortune which he inherited from his father enabled him, however, to follow out the bent of his genius, and the last twenty-five years of his life were a continuous triumph. He died in 1875. He frequently painted figure subjects, including the large sacred pictures, the Flight into Egypt and the Baptism of Christ; but his most characteristic and successful work was in landscape. His woodland scenes, painted for the most part at dawn or twilight in a scheme of pale greens and silvery grays, show a singularly subtle feeling for this phase of nature, and are undoubtedly among the most important contributions of the century to landscape art. Few artists have been so successful in painting light and air, or in infusing work manifestly closely studied from nature with an ideal charm. His defect is one of limitation in range, but within this limit he has no rival.

Coro'zo-nuts, the seeds of a tropical American palm, the *Phytelēphas macrocarpa*, whose hardened albumen, under the name of vegetable ivory, is used for small articles of turnery-ware.

Cor'poral (French, *caporal*, from L. *caput*, the head, the corporal being formerly a superior officer), in the British army, as also in that of the United States, a petty officer ranking just above the ordinary private and below the sergeant. He has charge of one of the squads of the company, places and relieves sentinels, &c. In the United States service the lowest commissioned officer of a company.

Corpora'tion, in law, a civil or political body in which are vested certain rights or privileges with a view to their preservation in perpetual succession. A corporation may consist of one person only and his successors, when it is called *sole* (the sovereign of Britain for example); or of a number of persons, when it is called *aggregate*. When a corporation is vested in a single person, that person is looked upon in regard to the rights of the corporation as holding a representative or official position, and these rights belong to and are transmitted by him in virtue of this position, and not as natural rights. In like manner the rights and powers of an aggregate corporation do not consist of the natural rights of the members, but of the rights held and duly exercised by the terms of the corporation. Corporations may be either public or private. An instance of the former is a municipal corporation under the management of the State or of the United States government. Private corporations do not fulfil any function of public government. They may be either ecclesiastical or lay. Ecclesiastical corporations are created to enable religious societies to manage with greater facility their temporal concerns. Lay corporations are private corporations not under immediate control of some religious body.

Corporation and Test Acts, two acts of note in English history. The Corporation Act, passed in 1661, prevented any person from being legally elected to any office belonging to the government of any city or corporation in England, unless he had, within the twelvemonth preceding, received the sacrament of the Lord's supper according to the rites of the Church of England. The Test Act, passed in 1673, required all officers, civil and military, to take the oaths, and subscribe a declaration against transubstan-

tiation in the courts of King's Bench or Chancery, within six months after their admission; and also within the same time to receive the sacrament of the Lord's supper according to the usage of the Church of England, in some public church. The Corporation Act was principally directed against Protestant Nonconformists; the Test Act against Roman Catholics. In the year 1828 they were both repealed.

Corps (kōr; French for body), a word often used as a military and a political term.—*A corps d'armée*, or *army corps*, one of the largest divisions of an army.—*Corps diplomatique*, the body of ministers or diplomatic characters.—*Corps législatif* (kōr lā-zhis-lā-tēf), the lower house of the French legislature in 1857–70. Its members were elected for six years in the proportion of 1 to 35,000 electors.

Cor'pulence, the unwieldy state of the human body due to the excessive deposition of fat. It is promoted by a diet too rich in fat-forming materials, fats, starch and sugars, bodily inactivity, tranquillity of mind, &c. There is, however, a diseased state of the system, which, independently of all these influences, will increase the production and deposition of fat. If corpulence is excessive it becomes troublesome and at length dangerous. In curing corpulency due attention must be paid to the regulating of the diet, exercise, and sleep of the individual. Especial attention must be given to the kind of diet. Avoid all kinds of fat-forming food, such as fat, cream, butter, sugar, potatoes, farinaceous food and malt liquors, and indeed alcoholic liquors of all kinds. Little bread should be eaten: a moderate increase in animal foods, lean beef, fish, fowl, eggs, is allowed: green vegetables and fresh fruit may be partaken of. Regular exercise to suit the person's powers should be engaged in. A noted instance of corpulency is Daniel Lambert, who weighed over 50 stone, or more than 700 lbs. Moderate corpulence may be quite consistent with health.

Corpus Christi ('body of Christ'), the consecrated host at the Lord's supper, which, according to the doctrines of the R. Catholic Church, is changed by the act of consecration into the real body of Christ. This doctrine caused the adoration of the consecrated host, and hence the R. Catholic Church has ordained for the host a particular festival, called the *Corpus Christi feast*. This was instituted in 1264 by Pope Urban IV. by a bull, in which he appointed the Thurs-

day of the week after Pentecost for the celebration of the Corpus Christi festival throughout Christendom. Since then this festival has been kept as one of the greatest of the Catholic Church. Splendid processions, in which the host is carried by a priest in a precious box, form an essential part of it. In France it is known as the *Fête-Dieu*.

Corpus Christi College, CAMBRIDGE, called also *Benet College*, was founded about 1352 by the united guilds of Corpus Christi and the Blessed Virgin, two fraternities of townspeople which used to meet for prayers at St. Benedict Church and St. Mary's respectively. The endowments of the college were considerably increased by Archbishop Parker, who also bequeathed to it his valuable collection of manuscripts.

Corpus Christi College, OXFORD, a college founded by Richard Fox, bishop of Winchester, under the license from Henry VIII. in 1516. The foundation consisted of twenty fellows and twenty scholars.

Corpus'cular Theory of Light, the older theory, which explained the phenomena of light by supposing that a luminous body emits excessively minute particles of matter, corpuscles as they were called, which striking the eye produce the sensation of light. Newton held the corpuscular theory, and supported it with great ingenuity. This theory has long been displaced by the *undulatory theory* (which see).

Corpus Juris ('body of law') is a name given to certain collections of laws. The name of Corpus Juris Civilis ('body of civil law') in particular was bestowed in the 12th century upon the general body of legal works drawn up at the orders of Justinian, viz. the Institutes, Pandects, Code and Novels; together with the collections bearing on the feudal law appended to them. With the canonical or Papal laws the same mode of proceeding has been adopted, and the Corpus Juris Canonici compiled.

Corral', in South America and elsewhere, a yard or stockade for cattle.

Correction of the Press, the correction of printed matter before publication. The first impression taken from the types is called a *proof*, and almost always contains some errors. In correcting proofs for the printer the following signs are used:—When a wrong word or letter occurs, a line is drawn through it, and the proper word or letter written on the margin opposite. If a clause, word, or letter is omitted, a caret (^) is marked at the place, and the omission is written on the

margin. If a superfluous letter or word occurs, the pen is drawn through it, and the character \mathcal{D} , signifying *dele* (delete, or take out), written in the margin. Where words are improperly joined, a caret is written at the place where the separation should be made, and the mark $\#$ written in the margin. When syllables or words are improperly separated, they are joined by horizontal parentheses, as *du ty*. These parentheses are to be made in the margin as well as at the break. When words are transposed, they are to be connected by a curved line, as *not is* when set up for 'is not,' and the mark *tr.* (transpose) is to be written in the margin. When a letter is turned, a line is drawn under it, and the mark \mathcal{D} made in the margin. When punctuation is omitted, or requires to be altered, a caret is put at the place, and the comma or period, &c., is placed in the margin, with a stroke behind it, as ,/. If a mark of quotation or superior letter has been omitted, the caret is made as before, and a mark of this sort \surd , \surd' , or \surd^c , placed in the margin. Words which are to be printed in italics are marked beneath with a single line; as, *office* (*office*): if in small capitals, with two lines, as *Greece* (*GREECE*): if in full capitals, with three, as *James* (*JAMES*). Where these marks are used in correction, the abbreviations *ital.*, *small caps.*, or *caps.* should be written in the margin. Where a word printed in italics is to be altered to roman letters, a line is to be drawn under it, and the word *rom.* written in the margin. Where a corrector, after altering a word, changes his mind, and prefers to let it stand, dots are placed under the word in the proof, and the word *stet* (let it stand) written in the margin. When two paragraphs are desired to be joined, the end of the one and the beginning of the other paragraph are connected by a curved line \frown , and the words *run on* written in the margin. Where a new paragraph is desired to be made, the mark [is inserted at the place, and the word *par.* written in the margin. The corrections should always be written on the margin of the proof so as to ensure notice by the printer; and when these are numerous or intricate, it is advisable to connect them by a line drawn from the place where they are to be made.

Correggio (kor-rej'ō), ANTONIO ALLEGRI, Italian painter, born at Correggio, near Modena, in 1494. Little is known of his life, which was very retired. Almost the only anecdote told of him is that on seeing the St. Cecilia of Raphael he exclaimed 'Anch 'io son pittore' (I also am a painter), but this is doubtful. Correggio is unrivalled in chiaroscuro and in the grace and rounding of his figures. Among his best pictures are Night, in which the chief light is the glory beaming from the infant Saviour; the St. Jerome; the Marriage of St. Catherine; several Madonnas, one of them (called La Zingarella, or the Gipsy Girl) said to represent his wife; the Penitent Magdalene; the altar-pieces of St. Francis, St. George, and St. Sebastian; Christ in the Garden of Olives; the fresco of the Ascension in the Church of St. John, Parma; the Assumption of the Virgin in the cathedral of the same city; the Ecce Homo, and Cupid, Mercury, and Venus, both in the National Gallery, London. He died in 1534.

Correlation of Physical Forces, a term introduced by Mr. Grove to denote what may more properly be called the convertibility of the various forms of energy. The energy, for instance, which a bullet in rapid motion possesses, is converted into heat when it strikes the target; the bullet being then warm to the touch. So heat may again be converted into *kinetic energy*, that is, the form of energy possessed by a moving body; for instance, through the intermediation of a steam-engine. Heat is also directly converted into electricity, and electricity into heat. In connection with this doctrine that of the conservation of energy ought also to be studied.

Corrèze (kor-rāz), an inland department, France, formed from part of the former province of Limousin, and deriving its name from the river Corrèze, by which it is traversed; area, 2265 square miles; capital, Tulle. It belongs almost entirely to the basin of the Garonne. Except in a few valleys the soil is far from fertile, heaths occupying a great extent of surface, and agriculture being in a very backward state. Pop. 1891, 328,119.

Corrib, LOUGH, a large lake in Ireland, mostly in county Galway, partly also in county Mayo, about 23 miles in length, and varying from 2 to 6 miles in breadth. It receives the drainage of Lough Mask through a subterranean channel, its own waters being carried by Galway river to Galway Bay.

It has some fine scenery on its northern and western shores, contains numerous islands, and, next to Lough Neagh, is the largest lake in Ireland.

Corridor (Italian and Spanish), in architecture, a gallery or long aisle leading to several chambers at a distance from each other, sometimes wholly inclosed, sometimes open on one side. In fortification, *corridor* signifies the same as *covert-way*.

Corrientes, a town, Argentine Republic, capital of the province of same name, on the Paraná, near its confluence with the Paraguay, 390 miles N. Buenos Ayres. It is well placed to serve as an entrepôt of goods, between the upper parts of the Paraguay and the Paraná, and the seaports on the La Plata. Pop. 15,500. Pop. of prov. 290,000.

Corrievrekin. See *Corryvreckan*.

Corrobory, a dance amongst Australian natives in which the performers, with shields in their hands, circle round a fire.

Corrody. See *Corody*.

Corrosives (Lat. *corrodere*, to eat away), in surgery, substances which eat away whatever part of the body they are applied to; such are glacial acetic acid, burned alum, white precipitate of mercury, red precipitate of mercury, butter of antimony, &c.

Corrosive Sublimate, the bichloride of mercury ($HgCl_2$), a white crystalline solid, an acrid poison of great virulence. The stomach-pump and emetics are the surest preventives of its deleterious effects when accidentally swallowed; white of egg is also serviceable, in counteracting its poisonous influence on the stomach. It is a powerful antiseptic.

Corrugated Iron, sheet-iron strengthened by being bent into parallel furrows. It is largely used for roofing, and when dipped in melted zinc, to give it a thin coating, is commonly known as *galvanized iron*.

Corruption of Blood. See *Attainder*.

Corryvreck'an, a place on the west coast of Scotland.

Corry, a city in Erie co., Pa. Machine shops, a tannery and several factories. Pop. in 1890, 5671.

Corsac, or **CORSAK** (*Vulpes corsac*), a species of yellowish fox or dog found in Central Asia, Siberia, and India. It is gregarious, prowls by day, burrows, and lives on birds and eggs.

Cor'sairs, the Anglicized form of the term used in the south of Europe to denote those pirates who sailed from Algiers, Tunis, Tripoli, and the ports of Morocco.

Corselet (kors'let): (1st) a cuirass or armour to protect the body from injury, worn formerly by pikemen, generally of leather, and pistol proof. (2d) The part of a winged insect which answers to the breast of other animals.

Corset, a piece of underclothing worn to give shape to the body, consisting of a sort of closely-fitting jacket, usually stiffened by strips of steel, whalebone, or other means, and tightened by a lace. The materials of which it is made should be smooth and elastic, and it should be specially fitted for the individual wearer, as no two human figures are precisely alike. It should be remembered, also, that corsets are meant to preserve a good figure, not to make one, and any forcible compression of the shape, especially on young persons, will only end in destroying natural grace of movement and in serious injury to the health.

Cor'sica (French, *Corse*), an island in the Mediterranean, forming the French department of same name. It is separated from the island of Sardinia, on the south, by the Strait of Bonifacio, about 10 miles wide; length, N. to S., 110 miles; breadth, near its centre, 53 miles; area, 3377 square miles. The east coast is almost unbroken, but on the west coast a number of deep bays, St. Fiorenzo, Calvi, Porto, Liscia, Ajaccio, and Valinco, follow in rapid succession. The interior is traversed by a mountain chain, the culminating point of which, according to the latest surveys, is Monte Cinto, 8891 feet high, Monte Rotondo coming next with 8775 feet. From the east and west side of the chain numerous streams flow to opposite sides of the coast, generally mere torrents. With the exception of some marshy districts on the east coast, the climate is very fine. There are fine forests containing pines, oaks, beeches, chestnuts, and cork-trees, and the mountain scenery is splendid. In the plains and numerous valleys the soil is generally fertile; but agriculture is in a backward state. Mules, goats, horses, cattle, and sheep, and amongst wild animals the boar, the fox, and the deer, are common. There are good fisheries. In minerals Corsica is not rich. The chief exports are wine, brandy, olive-oil, chestnuts, fruit, and fish. The chief towns, Ajaccio and Bastia, are connected by railway. The island was first colonized by the Phœnicians, from whom it got the name of Cynos. The Romans afterwards gave it that of Corsica. From the Romans it passed to the Goths, and from them to the Sara-

cens, and in the 15th century to the Genoese. France had the rights of the Genoese ceded to her, after Paoli had virtually made Corsica independent, and entered on forcible possession of it in 1768. An insurrection in 1794, headed by General Paoli and assisted by the British, for a time restored the island to independence; but in 1796 it again fell under the dominion of France. Pop. 1891, 288,596.

Corsicana, Navarro co., Tex., seat of military institute. Pop. 1890, 6285.

Corsned (A.-Saxon), formerly a piece of bread consecrated by exorcism, to be swallowed by any person suspected of a crime. If guilty, it was expected that the swallower would fall into convulsions, or turn deadly pale, and that the bread would find no passage. If innocent, it was believed the morsel would turn to nourishment.

Cor'so, an Italian term given to a leading street or fashionable carriage-drive.

Cort, HENRY, the inventor of the processes of puddling and rolling iron, born at Lancaster in 1740. He commenced business at Gosport, Hampshire; erected ironworks, and studied with great success methods of improving the process of manufacturing iron. By the unfortunate selection of a partner he was involved in a complication of lawsuits, and finally ruined. In 1794, however, he received a pension of £200 a year from government. He died in 1800.

Cortes (kor'tes), the old assembly of the estates in Spain and Portugal. In early times the king was very dependent upon them, especially in the Kingdom of Aragon. When the kingdoms of Aragon and Castile were united under Ferdinand and Isabella the crown succeeded in rendering itself more independent of the estates, and in 1538 Charles abolished the assembly of the estates in Castile altogether. Gradually the popular liberties were encroached upon, and the cortes at length were convened only for the purpose of homage or ceremony, or when a question regarding the succession arose. In 1808 Napoleon revived the cortes for his own ends. The present cortes of Spain are composed of a senate and congress equal in authority, and having the power along with the king to make laws. (See *Spain*.) The Portuguese cortes is coeval with the monarchy, and has had a history very similar to that of the Spanish.

Cor'tez, or CORTES, FERNANDO, or HER-
NAN, the conqueror of Mexico, was born in 1485 at Medellin, in Estremadura; died near Seville 1547. He went to the West

Indies in 1504, where Velasquez, governor of Cuba, under whom he had greatly distinguished himself, gave him the command of a fleet, which was sent on a voyage of discovery. Cortez quitted Santiago de Cuba in 1518, with eleven vessels, about



Fernando Cortez.

700 Spaniards, eighteen horses, and ten small field-pieces. He landed on the shore of the Gulf of Mexico, where he caused his vessels to be burned, in order that his soldiers might have no other resource than their own valour. Having induced the Totonacs and Tlaxcalans to become his allies he marched towards Mexico, where he was amicably received; but, having seized their monarch Montezuma, and treated the people with great cruelty, they finally resisted. After a desperate struggle, in which 100,000 Mexicans are said to have perished, the city was taken, and soon after the whole country was subjugated. In 1528 he returned to Spain; but two years after he was again sent out to Mexico, where he remained for ten years, discovering meanwhile the peninsula of California. He returned once more to Spain, where, notwithstanding his great services, he was coldly received and neglected. After taking part in an expedition to Algiers in 1541 he passed the remainder of his days in solitude. He left a character eminent for bravery and ability, but infamous for perfidy and cruelty.

Corto'na, a town of Italy. Pop. 3605.

Cortland, Cortland co., N.Y., at the junction of 3 railroads, has a State normal school and various factories. Pop. 1890, 8590.

Corto'na, PIETRO DI, properly *Pietro Berretini*, a painter and architect, was born at Cortona in 1596, died 1669. Pope Urban VIII. employed him to decorate a chapel in the church of St. Bibiena, and also

to execute the frescoes of the grand salon of the Barberini Palace. Many churches of Rome were decorated by him; and at Florence he adorned the Pitti Palace for the Grand-duke Ferdinand II. His easel pictures, although of less value than his larger works, are held in great estimation. As an architect he did some important work in church restoration.

Coruña (ko-rö'nyà). See *Corunna*.

Corun'dum, the earth alumina as found native in a crystalline state. In hardness it is next to the diamond. The amethyst, ruby, sapphire, and topaz are considered as varieties of this mineral, which is found in India and China, and is most usually in the form of a six-sided prism or six sided pyramid. It is nearly pure anhydrous alumina (Al_2O_3), and its specific gravity is nearly four times that of water. Its colour is various—green, blue, or red, inclining to gray, due to traces of iron, copper, &c. Emery is a variety of corundum.

Corun'na (Spanish, *Coruña*), a seaport of Spain, in the province of the same name in Galicia, on the north-west coast, on a peninsula at the entrance of the Bay of Betanzos. It consists of an upper and a lower town, the former built on the E. side of a small peninsula, and the latter on the isthmus connecting the peninsula with the mainland. The harbour, which is well protected, is deep, spacious, and safe, and many improvements have lately been made. Cattle form the chief export. There is a government tobacco factory employing 3000 women and girls. There is a lighthouse, 92 feet high, called the Tower of Hercules, and supposed to be of Roman construction. Corunna was the port of departure of the Spanish Armada (1588), and the scene of the repulse of the French and the death of Sir John Moore (1809). Pop. 34,098. See Map at *Ferrol*.—The province is hilly, and its inhabitants chiefly engaged in agriculture and fishing. Area, 3079 sq. miles; pop. 616,043.

Corvée (kor'vā), in feudal law, an obligation on the inhabitants of a district to perform certain services, as the repair of roads, &c., for the sovereign or the feudal lord. In France this system was not finally abolished until 1792.

Cor'vette, a vessel of war, ship-rigged, having a flush deck, with no quarter-deck and only one tier of guns; but the term is now somewhat loosely used. In the British navy there is a class of corvettes built of iron or steel, swift vessels, propelled by steam.

as well as by a large spread of canvas, and carrying heavy guns.

Cor'vey, or **KORVEI** (kor'vī), a formerly renowned Benedictine abbey near Höxter in the Prussian prov. of Westphalia, founded in 816, an early centre of German civilization. Wittekind, the historiographer of the convent, Bruno, known afterwards as Pope Gregory IV., and many other learned men, were educated here. To its library belonged the only MS. of the first six books of the Annals of Tacitus, discovered here in 1514. The abbey, or castle of Corvey, as it is now called, has a rich and extensive library; but the ancient collection of the Benedictines is no longer in existence.

Cor'vidæ, the crows, a family of conirostral birds, in which the bill is strong, of conical shape, more or less compressed, and the gape straight. The nostrils are covered with stiff bristle-like feathers directed forwards. The family includes the common crow, rook, raven, magpie, jay, jackdaw, nut-cracker, Cornish chough, &c.

Corvi'nus, **MATTHIAS**. See *Matthias Corvinus*.

Corvo, the smallest and most northerly of the Azores. Pop. about 1000.

Corwin, **THOMAS**, statesman, was born in Bourbon co., Ky., July 29, 1794. Elected to Ohio Legislature; to Congress; Governor of Ohio; to U. S. Senate; appointed Secretary of Treasury, and minister to Mexico. His style of oratory was captivating. He died in 1865.

Cor'yat, **THOMAS**, an eccentric English traveller, born in 1577; died at Surat, India, 1617. His wanderings, a great part on foot, were through Europe, Asia Minor, Persia, India, &c. His travels were published under such curious titles as Coryat's Crudities, Coryat's Crambe or Colwort twice sodden, &c. He acted as a sort of butt or foil to the wits with whom he associated in London.

Coryban'tes, frantic priests of Cybele, who celebrated the mysteries with orgiastic dances to the sound of drum and cymbal.

Cor'ymb, in botany, that form of inflorescence in which the flowers, each on its own pedicel of different lengths, are so arranged along a common axis as to form a flat broad mass of flowers with a convex or level top, as in the hawthorn and candytuft.



Corymb.

Cor'ypha, a genus of palms, including the fan-palm, gebang palm, and talipot.

Coryphæ'na, **COR'YPHENE**, a genus of fishes of the mackerel family (Scomberidæ). The body is elongated, compressed, covered with small scales, and the dorsal fin extends the whole length of the back, or nearly so. The dolphin of the ancients is the *C. hippūris*. All the species, natives of the seas of warm climates, are very rapid in their motions, and very voracious. They are of brilliant colours, and are objects of admiration to every voyager.

Coryphæ'us, the leader of the chorus in the Greek dramas. His functions were often as wide as those of our stage-manager, conductor, and ballet-master. The name *coryphée* is now applied to a ballet-dancer.

Coryphodon, a genus of extinct Ungulata, forming a link between the elephants and tapirs, having the ridges of its molar teeth developed into points; found in the Eocene formations of England and France.

Cos, now called **STANCHIO** or **STANKO**, an island in the Ægæan Sea, on the coast of Asia Minor; area, 95 square miles; pop. 11,000. It was the birthplace of Hippocrates, and had anciently a celebrated temple of Æsculapius. In Cos was manufactured a fine, semitransparent kind of silk, much valued by the ancients. Cos is also the name of the principal town, a decayed seaport. The island yields grain, wine, silk, cotton, citrons, &c.

Cosel. See *Kosel*.

Coseley, an urban sanitary district of West Staffordshire, 11 m. N. of Birmingham. It has extensive iron and other manufactures. Pop. 21,700.

Cosenza (ko-sen'tsà), an episcopal city of Southern Italy, capital of province of Cosenza or Calabria Citeriore, 150 miles S.E. Naples; pop. 16,253. It has manufactures of silk, pottery, and cutlery; the environs are beautiful, and produce abundance of corn, fruit, oil, wine, and silk.

Coshering, or **COSHERY**, an old feudal custom in Ireland by which the lord of the soil had the right to lodge and feast himself at a tenant's house. This tribute or exaction was at length commuted for a quit-rent.

Cosmas, surnamed **INDICOPLEUSTES** ('the Indian navigator'), an Alexandrian merchant and traveller of the 6th century; afterwards a monk. He wrote several geographical and theological works, the most important of which extant is the Christian Topography. The author tries to prove that the earth is

a parallelogram bounded by walls, which meet and form the vaulted roof which we call the sky.

Cosmet'ics (from Gr. *kosmeō*, I ornament, beautify), external preparations for rendering the skin soft, pure, and white, or for beautifying and improving the complexion. To these may be added preparations for preserving or beautifying the teeth, and those which are applied to the hair.

Cos'mism, that system of philosophy, based on the doctrine of evolution, enunciated by Mr. Herbert Spencer and his school; a phase of positivism.

Cosmog'ony (Greek, *kosmos*, world, and *gonē*, generation), a theory of the origin or formation of the universe. Such theories may be comprehended under three classes:—1. The first represents the world as eternal, in form as well as substance. 2. The matter of the world is eternal, but not its form. 3. The matter and form of the universe is ascribed to the direct agency of a spiritual cause; the world had a beginning, and shall have an end. Aristotle appears to have embraced the first theory; but the theory which considers the *matter* of the universe eternal, but not its *form*, was the prevailing one among the ancients, who, starting from the principle that nothing could be made out of nothing, could not admit the creation of matter, yet did not believe that the world had been always in its present state. The prior state of the world, subject to a constant succession of uncertain movements which chance afterwards made regular, they called *chaos*. The Phœnicians, Babylonians, and also Egyptians, seem to have adhered to this theory. One form of this theory is the atomic theory, as taught by Leucippus, Epicurus, and Lucretius. According to it atoms or indivisible particles existed from eternity, moving at hazard, and producing, by their constant meeting, a variety of substances. After having given rise to an immense variety of combinations they produced the present organization of bodies. The third theory of cosmogony makes God, or some deity, the Creator of the world out of nothing. This is an ancient and widely-spread theory, and is that taught in the book of Genesis. Anaxagoras was the first among the Greeks who taught that God created the universe from nothing. The Romans generally adopted this theory, notwithstanding the efforts of Lucretius to establish the doctrine of Epicurus.

Cosmos, order or harmony, and hence the universe as an orderly and beautiful system. In this sense it has been adopted by Humboldt as the title of his celebrated work, which describes the nature of the heavens as well as the physical phenomena of the earth.

Cosne (kōn), a town, France, dep. Nièvre, 31 miles N.N.W. Nevers, on the Loire. Pop. 5451.

Cos'sacks (*Casacks*), tribes who inhabit the southern and eastern parts of Russia, paying no taxes, but performing instead the duty of soldiers. Nearly all of them belong to the Græco-Russian Church, to which they are strongly attached, and to the observances of which they are particularly attentive. They must be divided into two principal classes, both on account of their descent and their present condition—the Cossacks of Little Russia and those of the Don. Both classes, and especially those of the Don, have collateral branches, distributed as Cossacks of the Azoff, of the Danube, of the Black Sea, of the Caucasus, of the Ural, of Orenberg, of Siberia, of the Chinese frontiers, and of Astrakhan. Writers are not agreed as to the origin of this people and of their name, but they are believed to be a mixed Caucasian and Tartar race. In personal appearance the Cossacks bear a close resemblance to the Russians, but are of a more slender make, and have features which are decidedly more handsome and expressive. Originally their government formed a kind of democracy, at the head of which was a chief or hetman of their own choice; while under him was a long series of officers with jurisdictions of greater or less extent, partly civil and partly military, all so arranged as to be able on any emergency to furnish the largest military array on the shortest notice. The democratical part of the constitution has gradually disappeared under Russian domination. The title of chief hetman is now vested in the heir-apparent to the throne, and all the subordinate hetmans and other officers are appointed by the crown. Care, however, has been taken not to interfere with any arrangements which foster the military spirit of the Cossacks. Each Cossack is liable to military service from the age of eighteen to fifty, and is obliged to furnish his own horse. They furnish the empire with one of the most valuable elements in its national army, forming a first-rate irregular cavalry, and rendering excellent service

as scouts and skirmishers. In 1570 they built their principal 'stanitza' and rendezvous, called Tcherkask, on the Don, not far above its mouth. As it was rendered unhealthy by the overflowing of the island on which it stood, New Tcherkask was founded in 1805 some miles from the old city, to which nearly all the inhabitants removed. This forms the capital of the country of the Don Cossacks, which constitutes a government of Russia, and has an area of 61,900 sq. miles and a population of 1,474,133. It has a military organization of its own.

Cossimbazar', a decayed town in Moorshedabad district, Bengal. It was one of the earliest settlements of the East India Company, and was formerly a place of great importance.

Cossipur', a northern suburb of Calcutta, the site of an important gun factory. Pop. 8770.

Costa, SIR MICHAEL, musical composer and conductor, born at Naples of an old Spanish family 1810, died 1884. In 1828 he came to England, and in 1839 became a naturalized British subject. He was conductor of the Philharmonic Society, the Sacred Harmonic Society, Her Majesty's Opera, the Handel Festivals, &c. His chief works are the opera Don Carlos and the oratorios Eli and Naaman. He was knighted in 1869.

Costa Rica, the most southern state of the republics of Central America; bounded N. by Nicaragua, E. and N. by the Caribbean Sea; E. and S. by Colombia; and S. and W. by the Pacific. The area is 21,495 sq. miles, including some disputed territories on the northern frontier. The country is intersected diagonally by the primary range or cordillera of the isthmus, which throws off numerous spurs on either side. The principal range contains several lofty eminences (the highest 11,740 feet) and volcanoes, both active and extinct or dormant. Costa Rica is said to contain some rich gold-mines; at present, however, they are not worked to any great extent. Silver and copper are also found. The country is extremely fertile. Coffee, rice, maize, &c., are raised on the table-land in the interior; and cacao, vanilla, sugar, cotton, tobacco, &c., are cultivated in the low coast-regions. Coffee forms the most important product. The forests are valuable. The capital is San José, and the two established ports are Punta Arenas, on the Pacific side, and Porto Limon, on the Caribbean Sea. It has been an independent state

since 1821, from 1824 to 1839 forming a part of the Central American Confederation, but subsequently separate. In 1891 there were 161 miles of railway and 630 miles of telegraph lines. The finances are in some disorder, and education is at a low ebb. The exports of 1891-92, 8,484,115 pesos; imports, 8,351,029 pesos. Pop. 213,785, mostly of Spanish descent.

Costello, DUDLEY, novelist and journalist, born in Ireland 1803, died in London 1865. A constant contributor to many journals and magazines, and author of several popular works of fiction, &c.—His sister LOUISA STUART COSTELLO, born 1815, died 1870, published two romances, entitled *The Queen Mother* (1841) and *Clara Fane* (1848), a poem called *The Lay of the Stork* (1856), and various historical and descriptive works.

Coster, LAURENS (called *Janszoon*, that is, *son of John*), whose name is connected with the origin of printing, was born in Haarlem in 1370 or 1371, died about 1440. He was sacristan (*Koster*) of the parochial church at Haarlem, and from this office he derived his surname. According to a statement first found in Junius' *Batavia* (1588), he was the original inventor of movable types, and on this ground the Dutch have erected statues in his honour. But in 1870 a Dutchman, Dr. Van der Linde, professed to have demolished the claims of Haarlem to the invention of printing, and to have established that Holland, like other countries, was indebted for it to the Mayence school. This conclusion has been rejected by Mr. J. H. Hessels, who, on carefully investigating the matter, thinks it highly probable that Coster was the inventor.

Cost'mary (from L. *costos*, an aromatic plant, and *Mary*, the Virgin), or **ALECOST** (*Balsamita vulgâris*), a composite herbaceous plant, a hardy perennial, a native of Italy, introduced into Britain in 1568, and common in almost every rural garden. It was formerly put into ale to give it an aromatic flavour, hence the name *Alecost*.

Costs, in law, are the expenses incurred by the plaintiff and defendant. As a rule these are paid by the loser in a suit, but there are always *extra-judicial* expenses incurred by both parties, which each has to pay whatever be the issue of the suit. In criminal cases the party accused may have his expenses if the court thinks the accusation unreasonable. In matrimonial suits, the wife, whether petitioner or respondent, is generally entitled to her costs from the husband.

Cos'tume, the style of attire characteristic of an individual, community, class, or people; the modes of clothing and personal adornment which prevail in any period or country.—*Costume balls*, also called *fancy dress balls*, are entertainments at which the guests adopt a style of dress different from the one usually worn. It may be one which was worn at another period, or one worn in another country, or a modern dress worn by some particular class of society. A favourite plan is to make up as some well-known character in history or literature.

Côte-d'Or (kōt-dōr), that is, hill or hillside of gold, from the excellence of its vintages, a chain of hills in the east of France, height from 1400 to 1800 feet. See next article.

Côte-d'Or, an inland and eastern department of France, part of the old province of Burgundy, having Dijon as its capital. It is watered by the Seine, the Saône, and their affluents, and derives its name from the Côte-d'Or hills (see above), which traverse it from N.E. to S.W. Area, 3382 sq. miles. The vineyards of the eastern slopes of the Côte-d'Or produce the celebrated wines of Upper Burgundy. Iron, coal, marble, &c., are found. Pop. 1891, 376,866.

Côtes-du-Nord (kōt-dü-nōr), a maritime department in the N. of France, forming part of ancient Brittany; capital Briec. Area, 2659 sq. miles. The coast extends about 150 miles, and the herring, pilchard, and mackerel fishing is actively pursued. One of the main branches of industry is the rearing of cattle and horses. In manufacturing industries the principal branch is the spinning of flax and hemp, and the weaving of linen and sail-cloth. Among the minerals are iron, lead, and granite. Pop. 618,652.

Coteswold (or **COTTESWOLD**) **Hills**. See *Cotswold Hills*.

Cöthen. See *Coethen*.

Cothur'nus. See *Buskin*.

Coti'dal Lines, a system of lines on a globe or chart marking the places where high-water takes place at the same instant.

Cotil'ion, a brisk dance of French origin performed by eight persons together, resembling the quadrille which superseded it. The name is now given to a dance which often winds up a ball, and which is danced with any number of dancers and with a great variety of figures, the pairs of dancers following in this the leading pair, and partners being successively changed.

Cotingas, a family of tropical American birds, some of which have splendid plumage, or are otherwise remarkable. See *Bell-bird*, *Umbrella-bird*.

Coto, the reddish-brown, aromatic and slightly bitter bark of *Palicourea densiflora*, order Rubiaceæ, a tree of S. America, imported into Europe and used as a remedy in diarrhoea and profuse sweating.

Cotoneas'ter, a genus of small trees or trailing shrubs, nat. order Rosaceæ. *C. vulgāris* is a British species, having rose-coloured petals and the margins of the calyx downy. The other species are natives of the south of Europe and the mountains of India. They are all adapted for shrubberies.

Cotopax'i, the most remarkable volcanic mountain of the Andes, in Ecuador, about 60 miles N.E. of Chimborazo; lat. 0° 43' S.; lon. 78° 40' W.; altitude 19,500 feet. It is the most beautiful of the colossal summits of the Andes, being a perfectly symmetrical truncated cone, presenting a uniform unfurrowed field of snow of resplendent brightness. Several terrific eruptions of it occurred in the course of the 18th and the beginning of the present century.

Cotrone (ko-trō'nā), a seaport of Southern Italy, province of Catanzaro, on the site of the ancient Croton. It has a cathedral, is defended by a citadel and otherwise fortified. Pop. 9649.

Cots'wold Hills, a range of hills, England, county Gloucester, which they traverse N. to S. for upwards of 50 miles; extreme elevation near Cheltenham, 1134 feet. The *Cotswold sheep* are a breed of sheep remarkable for the length of their wool, formerly peculiar to the counties of Gloucester, Hereford, and Worcester.

Cotta, JOHANN FRIEDRICH, BARON VON, an eminent bookseller of Germany, born 1764, died 1832. He began business at Tübingen, but in 1811 removed to Stuttgart. He was the publisher for many great writers in Germany, including Goethe, Schiller, Wieland, Richter, Uhland, Fichte, Hegel, the Humboldts, and others.

Cot'tabus, an ancient Greek game, which consisted in throwing wine from cups, without spilling, into little basins of metal, suspended in a particular manner or floating in water.

Cottage, a small country residence or detached suburban house, adapted to a moderate scale of living, yet with all due attention of neatness, comfort, and refinement.

COTTBUS — COTTON.

Cottbus. See *Kottbus*.

Cottier Tenure, a system of tenure according to which labourers rent small portions of land directly from the owner, or from a farmer, often giving personal service as part of the rent, and holding by annual tenancy.

Cottin (kot-an), SOPHIE RISTAUD, better known by the name of *Madame Cottin*, French novelist, born 1773, died 1807. In 1790 she married M. Cottin, a banker of Bordeaux, who died in 1793, and thenceforth she followed literature. Her best-known work is *Elizabeth, or the Exiles of Siberia*; other novels are *Claire d'Albe*, *Malvina*, *Amélie*, and *Mathilde*.

Cottle, JOSEPH, a bookseller and publisher of Bristol, and the author of some now almost completely forgotten poems, was born in 1774, died 1853. He was a generous friend to Coleridge and Southey in their early days, and wrote an interesting volume of recollections of those authors.

Cotton, the name given to the soft cellular hairs which encircle the seeds of plants of the genus *Gossypium*, nat. ord. Malvaceæ. The genus is indigenous to both the Old and the New World, and the plants are now cultivated all over the world within the limits of 30° north and south of the equator. All the species are perennial shrubs, though in cultivation they are sometimes treated as if they were annuals. They have alternate stalked and lobed leaves, large yellow flowers, and a three or five celled capsule, which bursts open when ripe through the middle of the cell, liberating the numerous black seeds covered with the beautiful filamentous cotton. The North American cotton is produced by *Gossypium barbadense*, and two well-marked varieties are cultivated, the long-staple cotton, which has a fine soft silky fibre nearly 2 inches long, and the short-staple cotton, which has a fibre little over 1 inch long adhering closely to the seed. The long-staple variety known as Sea Island cotton holds the first place in the market. It is grown in some of the southern states of America, especially on islands bordering the coast. The cotton grown in South America is obtained from *G. peruvianum*, called also kidney cotton. The indigenous Indian species is *G. herbacæum*, which yields a short-stapled cotton. It is grown throughout the Mediterranean region as well as in Asia. The mode of cultivation is usually as follows:—The seeds are sown in the spring in drills of about a yard in width, the plant appearing above ground in

about eight days afterwards. The rows of young plants are then carefully weeded and hoed, a process which requires to be repeated at two or three subsequent periods. No hoeing takes place after the flowering has commenced, from which a period of seventy days



Herbaceous Cotton Plant (*Gossypium herbacæum*).

generally elapses till the ripening of the seed. To prevent the lustre of the cotton wool from being tarnished, the pods must not remain ungathered longer than eight days after coming to maturity. The cotton wool is collected by picking with the fingers the flakes from the pods, and then spreading out to dry, an operation which requires to be thoroughly performed. The cotton now comes to be separated from the seeds, a process formerly effected by manual labour, but which is now generally accomplished by machinery. After being cleansed from the seeds, the cotton wool is formed into bales, and is now ready for delivery to the manufacturer.

Cotton has been cultivated in India and the adjacent islands from time immemorial. It was known in Egypt in the 6th century before the Christian era, but was then probably imported from India. It was not till a comparatively late period that the nations of the West became acquainted with this useful commodity, and even then it appears only to have been used as an article of the greatest luxury. The introduction of the cotton-shrub into Europe dates from the 9th century, and was first effected by the Spanish Moors, who planted it in the plains of Valencia. Cotton manufacturing factories were shortly afterwards established

at Cordova, Granada, and Seville; and by the 14th century the cotton stuffs manufactured in the Kingdom of Granada had come to be regarded as superior in quality to those of Syria. About the 14th century cotton thread began to be imported into England by the Venetians and Genoese. In China the cotton-shrub was known at a very early period, but it does not appear to have been turned to any account as an article of manufacture till the 6th century of the Christian era, nor was it extensively used for that purpose till nearly the middle of the 14th century. In the New World the manufacture of cotton cloth appears to have been well understood by the Mexicans and Peruvians long before the advent of Europeans. It was planted by the English colonists of Virginia in 1621, but only as an experiment, and the amount produced was long very small, the crop only amounting to about 2, 00,000 lbs. in 1791. The quantity now produced is enormous, being estimated at 9,038,707 bales, of 440 lbs. each. Cotton-seed, formerly a waste product, now forms an essential portion of the value of the crop. See *Cotton-seed Oil*. The chief cotton-growing states are Mississippi, Georgia, Texas, Alabama, Arkansas, S. Carolina, Louisiana, N. Carolina, Tennessee, and Florida. The raw cotton exported in 1892 was valued at \$258,447,741.

The cottons of commerce are usually distinguished by geographical names, borrowed from the countries in which the article is produced, and under each of these divisions various qualities are recognized. The chief contributors to the European supply are the United States, India, Egypt, and Brazil. The total import of raw cotton into Britain in 1887 was almost exactly 16,000,000 cwts., valued at £40,000,000. In the same year 4,900,000,000 yards of cotton piece goods were exported of the value of £51,737,000, cotton twist and yarn being also exported to the value of £11,379,000, sewing thread to the value of £2,979,000; the total value of all the manufactures exported reaching the sum of £70,959,766. Raw cotton was exported to the value of £5,727,000. There were in operation in Great Britain in 1891 44,750,000 spindles; in the United States, 14,781,000; on the Continent, 25,150,000. For the manufacture of cotton see *Cotton-spinning*.

Cotton, CHARLES, an English writer, born 1630, died 1687. He lived the life of a country gentleman, being a great angler

and skilled in horticulture. His works are numerous, including *Scarronides*, or *Virgil Travestie*, *Instructions how to Angle for a Trout and Grayling in a Clear Stream*, a supplement to his friend Izaak Walton's *Complete Angler*; *Poems on Various Occasions*; translations of Montaigne's *Essays*, Corneille's *Horace*, &c. He wrote well both in poetry and prose.

Cotton, SIR ROBERT BRUCE, English antiquary and collector of literary relics; born 1570, died 1631. He assisted Camden in his labours on the *Britannia*; and was made a baronet in 1611. He wrote numerous antiquarian pamphlets, but he is chiefly remembered for the magnificent library of ancient charters, records, and other MSS. which he collected, and which passed to his heir intact, and was acquired by the nation in 1706. After being partially destroyed by fire in 1731, it was placed in the British Museum in 1757.

Cotton Famine, the destitution caused by the outbreak of the American civil war (1861-65) in the English cotton manufacturing districts, especially in Lancashire. The cotton supply failed on account of the blockade of the southern ports of the U. States, and in consequence the mill-owners finally closed their mills entirely—nearly two millions of people being reduced to great distress. A Cotton District Relief Fund was started, and a Relief Act passed by parliament, by which loans were granted to the guardians of the poor for the purpose of instituting relief works. Gradually the difficulties were overcome, and by June 1865 the distress was at an end, greatly increased supplies of cotton having been got from Brazil, Egypt, India, and elsewhere.

Cotton-grass, the popular name of plants of the genus *Eriophorum*, order Cyperaceæ or sedges. Several species occur in the U. S. and in G. Britain, in moory or boggy places, and the white cottony substance they produce is used for stuffing pillows, &c.

Cottonian Library. See *Cotton, Sir Robert Bruce*.

Cotton-seed Oil, a valuable oil expressed from the seeds of the cotton plant, used as an adulterant or as a substitute for various other oils. The oil-cake of cotton-seed is a valuable cattle-feeding substance.

Cotton-spinning, a term employed to describe in the aggregate all the operations involved in transforming raw cotton into yarn. The word 'spinning' has also a

more limited signification, being used to denote the concluding process of the series. The following affords a general notion of the nature and order of the successive operations carried on in the manufacture of cotton yarn:—(1) *Mixing*, the blending of different varieties of raw cotton, in order to secure economical production, uniform quality and colour, and an even thread in any desired degree. (2) The *willowing*, *scratching*, or *blowing*, an operation which cleans the cotton and prepares it in the form of a continuous lap or rolled sheet for the next process. (3) *Carding*, an operation in which the material is treated in its individual fibres, which are taken from the lap, further cleansed, and laid in a position approximately parallel to each other, forming a thin film, which is afterwards condensed into a sliver—a round, untwisted strand of cotton. (4) *Drawing*, the drawing out of several slivers to the dimensions of one, so as to render the new sliver more uniform in thickness, and to place the fibres more perfectly in parallel order. (5) *Slubbing*, the further drawing or attenuation of the sliver, and slightly twisting it in order to preserve its cohesion and rounded form. (6) *Intermediate* or *second slubbing*, a repetition of the former operation and further attenuation, not necessary in the production of coarse yarns. (7) *Roving*, a continuation of the preceding, its principal object being to still further attenuate the sliver, and give it a slight additional twist. (8) *Spinning*, which completes the extension and twisting of the yarn. This is accomplished either with the *throstle* or the *mule*. By means of the former machine the yarn receives a hard twist, which renders it tough and strong. By means of the latter yarns of less strength are produced, such as warps of light fabrics and wefts of all kind. (See *Thread* and *Weaving*.) Up to the middle of the last century the only method of spinning known was that by the hand-wheel, or the still more primitive distaff and spindle. In 1767 a poor weaver of the name of Hargreaves, residing at Stanhill, near Blackburn, in Lancashire, invented a machine for spinning cotton, which he named a *spinning-jenny*. It consisted at first of eight spindles, turned by a horizontal wheel, but was afterwards greatly extended and improved, so as to have the vertical substituted for the horizontal wheel, and give motion to from fifty to eighty spindles. In 1769 Arkwright, originally a barber's apprentice, took out a patent

for spinning by rollers. From the circumstances of the mill erected by Arkwright at Cromford, in Derbyshire, being driven by water-power, his machine received the name of the *water-frame*, and the thread spun on it that of *water-twist*. The next important invention in cotton-spinning was that of the *mule*, introduced by Mr. Samuel Crompton, of Bolton, in 1775, and so called from its combining the principle of the spinning-jenny of Hargreaves with the roller-spinning of Arkwright. Numerous improvements in cotton-spinning have been introduced up to the present day, but they are all modifications of the original inventions. Among these is the *throstle*, an extension and simplification of the original spinning-frame, introduced about the year 1810. The first machines set up in the United States were at East Bridgewater, Mass., in 1786, by two Scotchmen. In 1812 Francis C. Lowell introduced the Cartwright power-loom at Lowell, Mass., which is now the largest cotton-manufacturing centre in America. There are also extensive mills in active operation in Alabama, Georgia and other Southern states.

Cottus, a genus of fishes. See *Bull-head*.

Coturnix. See *Quail*.

Cotyle'dons, the seed-leaves or seed-lobes of the embryo plant, forming, together with the radicle and plumule, the embryo, which exists in every seed capable of germination. Some plants have only one cotyledon, and



Cotyledons.

1, Monocotyledon (seed of *Arum maculatum*). 2, Dicotyledon (seed of *Papaver Rhæas*). 3, Polycotyledon (seed of *Pinus sylvestris*).

are accordingly termed *monocotyledonous*; others have two, and are *dicotyledonous*. These differences are accompanied by remarkable differences in the structure of the stems, leaves, and blossoms, which form the basis for the division of flowering plants into two great classes. The embryo plant of the Coniferæ has many (three to twelve) cotyledons, and is called *polycotyledonous*. The cotyledons contain a supply of food for the use of the germinating plant. In some plants the store is very large, and in germination the seed-leaves remain under the ground, as in the pea and oak; in others the

store is not so large, and the seed-leaves appear above ground and perform the functions of true leaves; while there is a large class of seeds where the embryo is very small, and the food is stored up around it, as in wheat and the buttercup.

Couchant, in heraldry, said of a beast lying down with the head raised.

Couch (QUITCH, or QUICK) **Grass** (*Triticum repens*), a perennial grass, which is propagated both by seed and by its creeping root-stock, and is one of the most common and troublesome weeds of agriculture. When it first appears above-ground its blade is readily eaten by sheep. The roots are readily eaten by pigs, and when cleaned and boiled or steamed become a farinaceous and nutritious food for cows and horses. It is the grass eaten by dogs as a vomit.

Couching, an old operation for cataract, which consisted in passing a needle into the eye, and with it pushing the lens out of its place to leave the pupil of the eye clear.

Coucy (kö-sē), **RENAUD, CHATELAIN DE**, an old French poet, born about 1160; killed at Acre 1191. His songs are distinguished by great warmth of passion. He is the hero of a celebrated romance of the 13th century.

Cougar (kö'gär), a voracious quadruped of the cat kind, inhabiting most parts of America—*Felis concolor*. Its colour is a uniform fawn or reddish-brown, without



Cougar (*Felis concolor*).

spots or markings of any kind. It may attain a length of 9 feet, inclusive of the tail. In habits it is stealthy and cowardly, and seldom or never attacks man. It is by some called the puma or red tiger, and is one of the most destructive of all the animals of America, particularly in the warmer climates, where it carries off fowls, dogs, cats, and other domestic animals.

Cough, a sudden and forcible expiration immediately preceded by closure of the glottis or narrowed portion of the box of the windpipe. The force for the action is

obtained by a deep breath, then follows the closure of the glottis, succeeded by the expiratory effort forcing open the glottis. The action is performed by the expiratory muscles, that is the abdominal muscles, by whose contraction the diaphragm is forced up, and the muscles of the chest, by which the ribs are pulled down. The cavity of the chest being thus diminished air is driven out of the lungs. The object of the cough is usually to expel any foreign material in the lungs or air-tubes. The offending material may be there present as the result of inflammation, catarrh, &c. It may also have gained entrance from without. Thus the irritating material may be merely some food or drink which has slipped into the larynx, or it may be dust, &c., in the air inhaled, and the cough is the means of expelling the intruder. But cough may also be produced when there is no irritating material present. The larynx or windpipe may be in an inflamed and irritable condition, in which state even the entrance of cold air will excite coughing. Moreover, cough may be produced by irritation of nerves, distant from the lungs and air-passages, by what is called reflex action. Thus irritation of the stomach, irritation connected with the ear, irritation of certain nerves by pressure of growths, &c., may produce cough, when the respiratory organs are not directly affected at all. Irritation at the back of the throat, as of the tickling of a long uvula, and so on, also produces it. A catarrhal cough is generally considered unimportant, particularly if there be no fever connected with it. But every cough lasting longer than two or three days is suspicious, and ought to be medically treated.

Coulisse (kö-lis'), one of the side scenes of the stage in a theatre, or the space included between the side scenes; properly one of the grooved pieces of wood, &c., in which a flat scene moves.

Coulomb (kö-lōn), **CHARLES AUGUSTIN DE**, French physicist, born 1736 at Angoulême, died 1806. His fame rests chiefly on his discoveries in electricity and magnetism, and on his invention of the torsion balance.

Coumarin (kö'-), a vegetable proximate principle, obtained from the *Diptërix odorata* or Tonka bean, sweet woodruff, sweet-scented vernal grass, melilot, &c. It has a pleasant aromatic odour, and a burning taste; and is used in perfumery, in medicine, and to give flavour to certain varieties of Swiss cheese.

COUNCIL — COUNTER-IRRITANT.

Council (Lat. *concilium*), an assembly met for deliberation, or to give advice. The term specially applies to an assembly of the representatives of independent churches, convened for deliberation and the enactment of canons or ecclesiastical laws. The four general or œcumenical councils recognized by all churches are: 1, the Council of Nice, in 325, by which the dogma respecting the Son of God was settled; 2, that of Constantinople, 381, by which the doctrine concerning the Holy Ghost was decided; 3, that of Ephesus, 431; and 4, that of Chalcedon, 451; in which two last the doctrine of the union of the divine and human nature in Christ was more precisely determined. Among the principal Latin councils are that of Clermont (1096), in the reign of Urban II., in which the first crusade was resolved upon; the Council of Constance, the most numerous of all the councils, held in 1414, which pronounced the condemnation of John Huss (1415), and of Jerome of Prague (1416); the Council of Basel, in 1431, which intended a reformation, if not in the doctrines, yet in the constitution and discipline of the church; and the Council of Trent, which began its session in 1545, and laboured chiefly to confirm the doctrines of the Catholic Church against the Protestants. On the 8th of December, 1869, an œcumenical council, summoned by a bull of Pope Pius IX., assembled at Rome. This council adopted a dogmatic Decree or *Constitutio de Fide*, and a *Constitutio de Ecclesia*, the most important article of which latter declares the infallibility of the pope when speaking *ex cathedrâ*.

Council, AULIC. See *Aulic*.

Council, PRIVY. See *Privy-council*.

Council and Session, LORDS OF, the supreme judges of the highest court of Scotland. See *Session (Court of)*.

Council Bluffs, a city and important manufacturing centre, United States, Pottawattamie county, Iowa, on the left bank of the Missouri, opposite Omaha city, with which it is connected by a bridge 2750 feet in length and 50 feet above high water. The name is derived from a council held here with the Indians in 1804. Pop. 21,474.

Council of War, an assembly of officers of high rank called to consult with the commander-in-chief of an army or admiral of a fleet on matters of supreme importance.

Counsel, or COUNSELLOR, a person retained by a client to plead his cause in a court of judicature. (See *Barrister* and

Advocate.) The term counsel is used as a plural for a number of legal counsellors engaged together in a case.—*Queen's* or *King's Counsel*, are English barristers appointed counsel to the crown, on the nomination of the lord-chancellor, and taking precedence over ordinary barristers. They have the privilege of wearing a silk gown as their professional robe, that of other barristers being of stuff.

Count (Latin *comes, comitis*, a companion) appears to have been first used, as a title of dignity, in the reign of the Roman emperor Constantine (4th century), meaning originally the companion of a prince or high dignitary. After the fall of the Roman power the title was retained; and under Charlemagne it denoted equally a military or civil employment. About the end of the 15th century, in Germany, and under the last princes of the Merovingian race in France, the title appears to have become hereditary in certain families. The German title *Graf* corresponds to the title *Count* in other countries of Europe. In modern times the custom of styling all the sons of a count also counts makes this designation on the Continent very common, and the rank little more than nominal. In point of rank, the English earls are considered as corresponding to the continental counts, an earl's wife being styled a *countess*.

Count, in law, an independent part of a declaration or indictment, which, if it stood alone, would constitute a ground of action.

Count and Reckoning, in Scotch law, is the name of a form of process by which one party may be called upon to render a complete statement of accounts, and show the amount due between him and another.

Coun'terfoil, a kind of complementary and easily detached portion of a document, such as a bank cheque or draft, which is retained by the person giving the document, and on which is written a memorandum of the main particulars contained in the principal document.

Counter-irritant, in med. a substance employed to produce an artificial or secondary disease, in order to relieve another or primary one. The term is more specifically applied to such irritating substances as, when applied to the skin, redden or blister it, or produce pustules, purulent issues, &c. The commonest counter-irritants are such as mustard, turpentine, cantharides or Spanish flies, croton-oil, and the cauterizing.

Coun'terpoint, in music, a term equivalent to harmony, or the writing of a carefully planned accompanying part; or that branch of the art which, a musical thought being given, teaches the development of it, by extension or embellishment, by transposition, repetition, or imitation throughout the different parts. Counterpoint is divided into *simple*, *florid* or *figurate*, and *double*. *Simple counterpoint* is a composition in two or more parts, the notes of each part being equal in value to those of the corresponding part or parts and concords. In *florid counterpoint*, two or more notes are written against each note of the subject, or *canto-fermo*, and discords are admissible. *Double counterpoint* is an inversion of the parts, so that the base may become the subject, and the subject the base, &c., thus producing new melodies and new harmonies.

Coun'terscarp, in fort. the exterior talus or slope of the ditch, or the talus that supports the earth of the covered way. It often signifies the whole covered way, with its parapet and glacis.

Coun'tersign, a private signal, word, or phrase given to soldiers on guard, with orders to let no man pass unless he first give that sign; a military watchword.

Coun'tertenor, in music, one of the middle parts between the tenor and the treble; high tenor. It is the highest male adult voice, having its easy compass from tenor G to treble C, and music for it is written on the alto or C clef on the middle line of the staff. The lowest voices of females and boys have about the same register, and are sometimes inaccurately called countertenor. The correct term is *alto* or *contralto*.

Count-out, in the British House of Commons, the act of the speaker when he counts the number of members present, and, not finding forty, intimates that there is not a quorum, when the sitting stands adjourned. The proceedings may be continued, however few be present, provided no member formally moves a count.

Count Palatine, in England, formerly the superior of a county, who exercised regal prerogatives within his county, in virtue of which he had his own courts of law, appointed judges and law officers, and could pardon murders, treasons, and felonies. All writs and judicial processes proceeded in his name, while the king's writs were of no avail within the palatinate. The Earl of Chester, the Bishop of Durham, and the Duke of Lancaster were the Counts Palatine of Eng-

land, the corresponding counties being called *counties palatine*.

Country Dance, a rustic dance of English origin, in which many couples can take part. The performers are arranged face to face, the gentlemen on one side and the ladies on the other, and go through certain prescribed figures.

County, originally a district of a country subject to a *count* or earl. It is now a civil division corresponding with *shire* in England and Scotland. Each British county has its lord-lieutenant, its sheriff, and its court or courts, with various officers employed in the administration of justice and the execution of the laws. The larger counties are more or less divided for purposes of parliamentary representation, and also for the more convenient administration of justice. The provinces of Canada, the Australian colonies, and the several states of America are also divided into counties, for administrative purposes.

County Corporate, a city or town possessing the privilege of being governed by its own sheriffs and other magistrates, irrespective of the county in which it is situated, as London, York, Bristol, &c.

County Council. See *Local Government*.

County Courts are an ancient institution in England. Their jurisdiction was formerly very restricted, but they have had extensive powers conferred on them by recent acts of parliament. In the United States there is a regular court in each county, presided over by a judge elected by the people or appointed by the governor and senate.

County Palatine, a county under a count palatine. See *Count Palatine*.

Coup (kö; French, a blow), a term used in various connections to convey the idea of promptness and force.—*Coup de main*, a prompt, vigorous, and successful attack.—*Coup d'état*, a sudden decisive blow in politics; a stroke of policy; specifically, an exertion of prerogative to alter the laws or the constitution of a country without the consent or concurrence of the people expressed through their representatives, especially when such exertion is supported by armed force.—*Coup de soleil*. See *Sunstroke*.

Coupar-Angus, a police burgh, Scotland, partly in Forfar, but mainly in Perthshire. Pop. 2154.

Coupé (kö-pā), a four-wheeled carriage carrying two inside, with a seat for the driver outside.

Couple, in dynamics, two equal and parallel forces acting in different directions, and applied to the same body. The distance between their lines of action is called the *arm* of the couple, and the product of one of the two equal forces by this arm is called the moment of the couple.

Couplet, two verses or lines of poetry of equal length and rhythm, often embodying an idea of the nature of an aphorism.

Coupling, in machinery, a contrivance for connecting one portion of a system of shafting with another, and of which there are various forms. A common form is the flange or plate coupling, which consists of two flanges separately fitted on to the two contiguous ends of the lengths of shaft to be connected, and firmly secured together by screws. The most useful kinds of couplings are those that are adjustable, or can be readily put on and off.—The term is also applied to an organ register, by which two or more rows of keys can be connected by a mechanism, so that they can be played together.

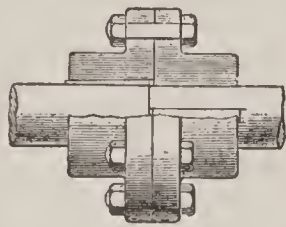

Flange Coupling.

Coupon (kō'pon; from Fr. *couper*, to cut), an interest-certificate printed at the bottom of transferable bonds, and so called because it is cut off or detached and given up when a payment is made. Also one of a series of tickets which binds the issuer to make certain payments, perform some service, or give value for certain amounts at different periods, in consideration of money received.

Courbevoie (kōrb-vvä), a town of France, department Seine, on the left bank of the Seine, 5 miles north-west of Paris, well built, with large barracks; pop. 14,729.

Courcelles (kōr-säl), a village of Alsace-Lorraine, 4 miles s.e. of Metz; scene of a German victory over the French under Bazaine, Aug. 14, 1870.

Courier, a bearer of special despatches, whether public or private; also an attendant on a party travelling abroad, whose especial duty is to make all arrangements at hotels and on the journey.

Courland (German, *Kurland*), a government in Russia, bounded n. by Livonia and the Gulf of Riga, w. the Baltic, s. Kovno, and e. by Vitebsk; area, 10,535 square miles; pop. 642,570. In the neighbourhood of Mittau, the capital, the surface is

diversified by hills of very moderate height; but elsewhere, and particularly towards the coast, it is flat, and contains extensive sandy tracts, often covered with heaths and morasses. About two-fifths of the whole government are occupied by wood. The peasantry are for the most part Letts; the more wealthy and intelligent classes Teutons; the prevailing religion being Lutheran. The territory was subjected to Poland in 1561, conquered by Charles XII. of Sweden in 1701, and was merged in Russia 1795.

Courser, or **COURIER** (*Cursorius*), a genus of grallatorial birds belonging to the plover tribe. They are found chiefly in Africa, but one species, the cream-coloured courser (*Cursorius isabellinus*), has been met with in Britain.

Coursing, a kind of sport in which hares are hunted by greyhounds, which follow the game by sight instead of by scent. Meetings are held in various localities, at which dogs are entered for a variety of stakes, as horses are at a race-meeting. When a hare is started it is allowed a certain advance on the dogs, which are then let loose from the 'slips' or cords held by the 'slipper' and fastened to the dogs' collars. A judge keeps his eyes on the dogs, and notes what are called 'points,' the victory being adjudged to the dog which makes the most 'points.'

Court.—(1) All the surroundings of a sovereign in his regal state; the body of persons who compose the household of, or attend on, a sovereign. *Presentation at Court* is a formal introduction of persons of some eminence or social standing to the British sovereign on certain state occasions appointed for the purpose. They have to appear in the regulation 'court dress.' (2) A tribunal of justice; the hall, chamber, or place where justice is administered, or the persons (judges) assembled for hearing and deciding causes, civil, criminal, military, naval, or ecclesiastical. Courts may be classified in various ways: A common distinction is into *courts of record* and *not of record*; the first being those the judicial proceedings of which are enrolled in records. They may also be divided into courts of *original jurisdiction* and courts of *appeal*, or of *appellate jurisdiction*, *inferior* and *superior* courts, &c. Articles on the different courts will be found under such separate headings, as *Chancery*, *Common Pleas*, *Exchequer*, &c.

Court-baron, in England, a court composed of the freeholders of a manor, presided

over by the lord of the manor or his steward. These courts have long fallen into disuse.

Court de Gébelin (kör-d-zhā-blān), ANTOINE, French writer, born in 1725, died in 1784. He published, from 1773 to 1774, *Le Monde Primitif Analysé et Comparé avec le Monde Moderne*, which, after nine volumes had appeared, remained unfinished. Its vast plan embraces dissertations on mythology, grammar, origin of language, history, &c. He also published *Lettres Historiques et Apologétiques en Faveur de la Religion Réformée*.

Courtesy, TENURE BY, in law, is where a man marries a woman seized of an estate of inheritance, and has by her issue capable of inheriting her estate. In this case, on the death of his wife he holds the lands for his life, as tenant by courtesy.

Courtesy Title, a title assumed by an individual or given to him by popular consent, to which he has no valid claim. When a British nobleman has several titles it is usual to give one of his inferior titles to his eldest son. Thus the eldest son of the Duke of Bedford is *Marquis* of Tavistock, and the Duke of Buccleuch's eldest son is *Earl* of Dalkeith. The younger sons of noblemen have the courtesy title of *Lord* prefixed to their names, as *Lord* William Lennox. In Scotland, the eldest son of a viscount or baron has the courtesy title of *Master*, as the *Master* of Lovat, eldest son of Lord Lovat.

Court Fool. See *Jester*.

Court Hand, the old Gothic or Saxon hand or manner of writing used in records and judicial proceedings, and distinguished from the modern or Italian style.

Court-martial, a court consisting of military or naval officers, for the trial of military or naval offences.

Court of Claims, in the U. States, created by act of congress in 1855, has jurisdiction to hear and determine all claims founded upon any act of Congress, or on any regulation of any executive department, or upon any contract, express or implied, with the government of the U. States; and all claims referred to it by either house of congress. The court holds one session annually. Members of congress are prohibited from practising in this court.

Courtrai (kör-trä; Flemish, *Kortryk*), a fortified town, Belgium, 26 miles south of Bruges, on the Lys. Here, in 1302, took place the 'battle of spurs' between the French and Flemings. It is well built, with handsome streets. Pop. 29,073.

Courts of Love, in the chivalric period of the middle ages, courts composed of knights, poets, and ladies, who discussed and gave decisions on subtle questions of love and gallantry. The first of these courts was probably established in Provence about the 12th century. They reached their highest splendour in France, under Charles VI., through the influence of his consort Isabella of Bavaria, whose court was established in 1380. An attempted revival was made under Louis XIV. by Cardinal Richelieu.

Cousin (kö-zān), VICTOR, French philosopher and writer, founder of the so-called Eclectic school of philosophy, was born at Paris 1792, died at Cannes 1867. He was educated at the Lycée Charlemagne, and entered the École Normale, then newly instituted, in 1811. His mind was directed towards philosophy under Laromiguière, Royer-Collard, and Maine de Biran. In 1815 Royer-Collard, returning to political life, recommended Victor Cousin as his successor, and he became deputy-professor of philosophy at the Sorbonne. He had also an appointment at the Lycée Napoléon, or Collège Henri IV., and at the École Normale. In the free discussions (*conférences*) which followed his prelections he became by the influence his eloquence exercised over his pupils the founder of a school which, while assuming an eclectic development, was originally based on the dogmatic teaching of the Scotch school. In 1817 he visited Germany, and became acquainted with the writings of Kant, Fichte, Jacobi, and Schelling, by whose opinions his own were henceforth modified. He lost his position as public teacher on political grounds in 1822, and did not resume teaching till 1828, when he shared with Guizot and Villemain an unexampled popularity, due partly to political feeling. After the July revolution (1830) he entered the Council of Public Instruction, to which he presented valuable reports on the state of public education in Germany and Holland. In the cabinet of Thiers in 1840 he accepted the office of minister of public instruction, and was created a peer of France. The revolution of 1848 brought his public career to a close. The head and founder of the modern school of eclecticism in France, he borrowed from many sources. His eclecticism was based on the principle that every system, however erroneous, which has anywhere commanded assent, contains some elements

of truth, by which its acceptance may be explained, and that it is the business of philosophical criticism to discover and combine these scattered elements of truth. The following are among his works:—Fragments Philosophiques (1826); Nouveaux Fragments Philosophiques (1828); Cours de Philosophie Morale (1840–41); Cours de l'Histoire de la Philosophie (1828); Histoire de la Philosophie au dix-huitième Siècle (1829); De la Métaphysique d'Aristote (1838); Philosophie Scolastique (1840); Du Vrai, du Beau et du Bien (1854); &c.

Cousins, SAMUEL, English engraver, born 1801, died 1887. He engraved plates after Lawrence, Landseer, Reynolds, Millais, Leslie, Eastlake, Ward, &c. He was elected a Royal Academician Engraver in 1855, and when this class was abolished he became an Academician proper.

Coutances (kō-tāns), a town, Northern France, dep. Manche, on a hill about 4 miles from the sea, with which it communicates by a canal. It has a fine old cathedral crowning the hill on which the town stands. Pop. 8107.

Couthon (kō-tōn), GEORGES, a noted French revolutionist, was born in 1756, and was bred to the profession of a lawyer. Some time after the revolution he was chosen a member of the national assembly, and allying himself with Robespierre aided and abetted the latter in all his atrocities. On the downfall of Robespierre's party Couthon shared, along with him and St. Just, in the decree of arrest, and was guillotined, July 28, 1794.

Couvade (kō-vād'), a singular custom prevalent in ancient as well as modern times among some of the primitive races in all parts of the world. After the birth of a child the father takes to bed, and receives the food and compliments usually given elsewhere to the mother. The custom was observed, according to Diodorus, among the Corsicans; and Strabo notices it among the Spanish Basques, by whom, as well as by the Gascons, it is still to some extent practised. Travellers from Marco Polo downwards have met with a somewhat similar custom among the Chinese, the Dyaks of Borneo, the negroes, the aboriginal tribes of North and South America, &c.

Covenant, in law, an agreement between two or more parties in writing signed, sealed, and delivered, whereby they agree to do, or not to do, some specified act. In theology, the promises of God as revealed in the

Scriptures, conditional on certain terms on the part of man, as obedience, repentance, faith, &c.

Covenant, in Scotch history, the name given to a bond or oath drawn up by the Scotch reformers, and signed in 1557, and to the similar document or Confession of Faith drawn up in 1581, in which all the errors of Popery were explicitly abjured. The latter was subscribed by James VI. and his council, and all his subjects were required to attach their subscription to it. It was again subscribed in 1590 and 1596. The subscription was renewed in 1638, and the subscribers engaged by oath to maintain religion in the same state as it was in 1580, and to reject all innovations introduced since that time. The *Solemn League and Covenant* was a solemn contract entered into between the General Assembly of the Church of Scotland and commissioners from the English parliament in 1643, having for its object a uniformity of doctrine, worship, and discipline throughout Scotland, England, and Ireland, according to the word of God and the example of the best reformed churches. In 1662 it was abjured by act of parliament, both in England and Scotland.

Covenanters, in Scottish history, the name given to the party which struggled for religious liberty from 1637 on to the revolution; but more especially applied to the insurgents who, after the passing of the act of 1662 denouncing the Solemn League and Covenant as a seditious oath (see above art.), took up arms in defence of the Presbyterian form of church government. The Presbyterian ministers who refused to acknowledge the bishops were ejected from their parishes and gathered round them crowds of their people on the hillsides, or any lonely spot, to attend their ministrations. These meetings, called 'conventicles,' were denounced as seditious, and to frequent them or to hold communication with those frequenting them was forbidden on pain of death. The unwarrantable severity with which the recusants were treated provoked them to take up arms in defence of their opinions. The first outbreaks took place in the hill country on the borders of Ayr and Lanark shires. Here at Drumclog, a farm near Loudon Hill, a conventicle was attacked by a body of dragoons under Graham of Claverhouse, but were successful in defeating their assailants (1679). The murder of Archbishop Sharp on Magus Moor, and this defeat, alarmed the government, who

sent a large body of troops under the command of the Duke of Monmouth to put down the insurgents, who had increased in number rapidly. The two armies met at Bothwell Bridge, where the Covenanters were totally defeated (June 22, 1679). In consequence of the rebellious protest called the *Sanquhar Declaration*, put forth in 1680 by Cameron, Cargill, and others, as representing the more irreconcilable of the Covenanters (known as Cameronians), and a subsequent proclamation in 1684, the government proceeded to more severe measures. An oath was now required of all who would free themselves of suspicion of complicity with the Covenanters; and the dragoons who were sent out to hunt down the rebels were empowered to kill anyone who refused to take the oath. During this 'killing time,' as it was called, the sufferings of the Covenanters were extreme; but notwithstanding the great numbers who were put to death, their fanatic spirit seemed only to grow stronger. Even after the accession of William some of the extreme Covenanters refused to acknowledge him owing to his acceptance of Episcopacy in England, and formed the earliest dissenting sect in Scotland. See *Cameron (Richard)*, and *Reformed Presbyterians*.

Covent Garden (that is, *convent garden*), a market-place in London, which formerly consisted of the garden belonging to the abbot and monks of Westminster. In 1831 the present market buildings were erected by the Duke of Bedford, the proprietor of the ground.—**COVENT GARDEN THEATRE** sprang out of one in Lincoln's-Inn-Fields, through a patent granted to Sir W. Davenant in 1662. It is associated with the names of Kemble, Siddons, Macready, &c.

Cov'entry, a city in England, county of Warwick, 85 miles north-west of London. It was formerly surrounded with lofty walls and had twelve gates, and was the see of a bishop early conjoined with Lichfield. Parliaments were convened here by the earlier monarchs of England, several of whom occasionally resided in the place. Pageants and processions were celebrated in old times with great magnificence, and a remnant of these still exists in the processional show in honour of Lady Godiva. (See *Godiva*.) There are still a few narrow and irregular streets, lined with houses in the style of the 15th and 16th centuries. There are several fine churches. Coventry is the centre of the ribbon trade. Pop. 46,563.

Coventry, Kent co., R. I., 18 miles s. w. of Providence; contains manufactories and National Bank. Pop. in 1890, 5068.

Cove of Cork. See *Queenstown*.

Cov'erdale, MILES, the earliest translator of the Bible into English, was born in Yorkshire in 1487, died 1568. He was educated at Cambridge, and was ordained priest in 1514. He was led some years afterwards to embrace the reformed doctrines, and, having gone abroad, assisted Tindall in his translation of the Bible. In 1535 his own translation of the Scriptures appeared, with a dedication to Henry VIII. Coverdale was almoner to Queen Catharine Parr, and officiated at her funeral. In 1551, during the reign of Edward VI., he was appointed Bishop of Exeter, but was ejected on the accession of Mary, and thrown into prison. After two years' confinement he was liberated, and proceeded first to Denmark, and subsequently to Geneva, where he was employed in preparing the Geneva translation of the Scriptures. On the accession of Elizabeth he returned to England, and held for a short time the rectory of St. Magnus, London Bridge.

Covered Way, a space of ground on the edge of the ditch round the works of a fortification between the counterscarp and the glacis, affording a safe communication round all the works.

Cov'erture, a legal term applied to the position of a woman during marriage, because she is under the cover or protection of her husband.

Covilha (ko-vil'yà), a town, Portugal, prov. of Beira, on the s.e. slope of the Serra da Estrella. In the neighbourhood there are noted sulphurous baths. Pop. 10,809.

Cov'ington, a city of Kentucky, U.S., on the s. bank of the Ohio River, opposite Cincinnati, of which it is substantially a suburb, connected by means of bridges and ferries. It has a large general trade and manufacturing business. Pop. 1890, 37,375.

Cow, the general term applied to the females of the genus *Bos* or ox, the most valuable to man of all the ruminating animals. Among the best breeds of dairy cows in Britain are the Devonshire, the Ayrshire, the short-horn, the polled Angus or Aberdeenshire, and the Alderney. See *Ox*.

Cowbane, or water-hemlock, *Cicuta virōsa*, a perennial, umbelliferous, aquatic plant, producing an erect, hollow, much-branched, striated stem, 3 or 4 feet high, furnished with dissected leaves. It is highly poisonous.

Cow-berry, the *Vaccinium Vitis idæa*, red whortleberry, a procumbent shrub of high moorlands in Europe, Asia, and N. America, has evergreen box-like leaves, and produces a red acid berry used for jellies and preserves.

Cow-bunting, the *Molothrus pecoris*, an American bird about the size of the European sky-lark, and belonging to the family Sturnidæ, or starlings. It drops its eggs into the nests of other birds to be hatched by them, but has never been known to drop more than one egg into the same nest. It is migratory, spending its winters regularly in the lower parts of North and South Carolina



Young Cow-bunting fed by female Yellow-throat

and Georgia, and appearing in Pennsylvania about the end of March. These birds often frequent corn and rice fields in company with the red-winged troopials, but are more commonly found accompanying the cattle, feeding on seeds, worms, &c.

Cowdee, same as *Kauri* (resin).

Cowell (kou'el), DR. JOHN, jurist, born 1554, died 1611. Author of a law dictionary, 1607, and *Institutiones Juris Anglicani*.

Cowen (kou'en), FREDERICK HYMEN, musical composer, born at Kingston, Jamaica, 1852. Chief works: *Rose Maiden*, a cantata, 1870; *The Maid of Orleans*, 1871; *The Corsair*, 1874; *St. Ursula*, cantata, 1881; *The Deluge*, oratorio; *Pauline*, opera; *Sleeping Beauty*, cantata, 1885; *Language of Flowers*, orchestral suite; *Ruth*, an oratorio, 1887; *Scandinavian and Welsh Symphonies*, and many popular songs.

Cowes (kouz), WEST, a seaport town and watering-place, England, Hampshire, north coast of the Isle of Wight, at the mouth of the river Medina. It is well known as a yachting port. Pop. 6487.—EAST COWES, on the opposite side of the river, is connected with it by a steam-ferry and floating-bridge. Pop. 2615.

Cow-grass. See *Cow-pea*.

Cow'itch, or COWHAGE (Hind. *kiwanch*), the hairs of the pods of leguminous plants, genus *Mucūna*, natives of the East and West Indies. The pod is covered with a thick coating of short, stiff, brittle, brown hairs, the points of which are finely serrated. They easily penetrate the skin, and produce an intolerable itching. They are employed medicinally (being taken in honey or syrup) as a mechanical vermifuge.

Cowley (kou'li), ABRAHAM, an English poet of great celebrity in his day, was born at London in 1618, died 1667. He published his first volume, *Poetic Blossoms*, at the age of fifteen. He entered Trinity College, Cambridge, in 1636, but was ejected as a royalist in 1643, and removed to St. John's College, Oxford. He engaged actively in the royal cause, and when the queen was obliged to quit England, Cowley accompanied her. He was absent from his native country nearly ten years, and it was principally through him that the correspondence was maintained between the king and queen. On the Restoration he returned with the other royalists, and obtained the lease of a farm at Chertsey, held under the queen, by which his income was about £300 per annum. Cowley's poems have failed to maintain their ancient popularity, but he still holds a high position as a prose writer and as an essayist. He took a considerable interest in science, and was one of the founders of the Royal Society. His chief works are: *Love's Riddle*, a pastoral comedy; *Davidis*, a scriptural epic; *Naufragium Jocularis*; *The Mistress*, a collection of love verses; *Pindarique Odes*; *Liber Plantarum*; &c.

Cowloon', or KOWLOON, a peninsula at the mouth of the Canton River, directly opposite to the island of Hong-Kong, to which crown colony it belongs.

Cow-parsnip, an umbelliferous plant, genus *Heracleum*, one species of which, *H. Sphondylium*, found in moist woods and meadows in England, grows to the height of 4 or 5 ft., and is used to feed pigs. Siberian cow-parsnip (*H. gigantæum*) is grown in gardens and shrubberies, reaching the height of 10 or 12 ft. *H. lanatum* is a common U. States species.

Cow-pea, COW-GRASS, *Trifolium medium*, a variety of clover cultivated in England and some parts of the United States for the same purpose as the common red (*T. pratense*).

Cowper (kö'pér or kou'pér), WILLIAM, English poet, born at Berkhamstead in

1731, died at East Dereham, in Norfolk, 1800. He was the son of a clergyman; lost his mother at the age of six, and was, when ten years of age, removed from a country school to that of Westminster, which he left at eighteen with a fair reputation for classical learning, and a horror of the school discipline, which he afterwards expressed in his *Tirocinium*. He was then articled for three years to a solicitor, where he had for a fellow-clerk Mr., afterwards Lord Thurlow. At the expiration of his apprenticeship he took chambers in the Middle Temple, and in 1754 was called to the bar. The interest of his family procured for him the post of clerk to the House of Lords; but having to appear for examination at the bar of the house, his nervousness was such that on the very day appointed for the examination he resigned the office, and soon after became insane. From December 1763 to June 1765 he remained under the care of Dr. Cotton at St. Albans. The skill and humanity of that gentleman restored him to health, and he retired to Huntingdon. Here he made the acquaintance of the Rev. Mr. and Mrs. Unwin, whose kindness, particularly that of the latter, seemed to have the most soothing and beneficial influence on him. On the death of Mr. Unwin, in 1767, he removed with Mrs. Unwin to Olney, the residence of the Rev. John Newton, who also became an intimate friend and exercised a powerful influence over his mind and conduct. Newton had resolved on publishing a volume of hymns, and secured the co operation of Cowper in composing them, but before their publication in 1776 he had been again attacked by his constitutional malady, by which, for ten years from 1773, his mind, with occasional intervals of recovery, was continually clouded. In 1776, by Mrs. Unwin's advice, he commenced a poem on the Progress of Error, which he followed by three other poems, Truth, Table-talk, and Expostulation; these with some others were published in a volume in 1782. Another female friend, Lady Austen, suggested the Task, which, together with *Tirocinium*, formed a second volume in 1785. The History of John Gilpin is also due to the suggestion of Lady Austen. The translation of Homer, begun in 1784, occupied him for the next six years, and was published in 1791. He removed during its progress, in 1786, from Olney to Weston. In the beginning of 1794 he was again attacked with

madness, which was aggravated by the death of Mrs. Unwin in 1796. The revisal of his Homer, and the composition of some short pieces, occupied the latter years of his life. He is considered among the best of our descriptive poets, and is one of the most easy and elegant of letter-writers.

Cow-pox, the vaccine disease which appears on the teats of the cow, in the form of vesicles of a blue colour, approaching to livid. These vesicles are elevated at the margin and depressed at the centre; they are surrounded with inflammation and contain a limpid fluid. This fluid or virus is capable of communicating genuine cow-pox to the human subject, and of protecting against small-pox either completely, or, at least, against the virulent form of the disease. See *Vaccination*.

Cowrie-pine. See *Kauri*.

Cowrie-shell, a small gasteropodous shell, the *Cypræa monēta*, used for coin in some parts of Africa and in many parts of Southern Asia. The beauty of the cowrie-shells has procured them a place among ornaments, and they have been in demand among civilized and uncivilized nations time out of memory. The shells used as currency occur principally in the Philippine Islands. They vary in value in different localities. In India 6000 to 7000 are equal to a rupee, while in the interior of Africa 200 are worth 8*d*. The name is also given to other shells of the genus *Cypræa*.

Cow'slip, the popular name of several varieties of *Primula veris*, order Primulacæ. a fragrant and pretty wild flower found in pastures and meadows. It has umbels of small, buff-yellow, scented flowers on short pedicels. Its flowers possess sedative properties, and have been used as an anodyne, a sort of wine being prepared from them.

Cow-trees, a name of various trees having an abundance of milky juice, especially of *Brosimum Galactodendron*, a South American tree, order Artocarpaceæ (bread-fruit), which, when wounded, yields a rich milky nutritious juice in such abundance as to render it an important article of food. This fluid resembles in appearance and quality the milk of the cow. The tree is common in Venezuela, growing to the height of 100 ft. The leaves are leathery, about 1 ft. long and 3 or 4 inches broad. In British Guiana the name is given to the Hya-hya (*Tabernaemontāna utilis*), a large much-branched tree belonging to the Apocynacæ; in the coun-

try of the Rio Negro to *Collophora*, a tree of the same family; and in Pará to a species of *Mimūsops*.

Cox, DAVID, an English landscape painter, born in 1783 in Birmingham, died at Harborne, near Birmingham, 1859. He was for several years engaged as scene-painter for various provincial and London theatres, and during a considerable portion of his early life he had to teach his art for a subsistence. After residing in London, Hereford, &c., he returned to Birmingham in 1841. His works are chiefly of English landscape, and in water-colours, a department which constituted his peculiar walk. His pictures are now very highly valued. In later life he painted a good deal in oil. He published a work on Landscape-painting and Effect in Water-colours.

Cox, REV. SIR GEORGE W., BART., M.A., English writer, born 1827; held some curacies in Devonshire, and afterwards became vicar of Bekesborne, Kent, and Scrayingham, York. He has published works on Greek history, the Mythology of the Aryan Nations, &c.

Coxis, or COXCIE, MICHEL J. VAN, Flemish painter, born about 1500, died in 1592. He travelled to Rome, where he remained several years attracted by the works of Raphael. Here he executed several paintings in fresco, and many other pieces. For Philip II. of Spain he executed an admirable copy of Van Eyck's altar-piece at Ghent. His works are now rare.

Coxswain. See *Cockswain*.

Coyne and Livery, an ancient right or custom in Ireland which enabled the lord or chief to quarter his soldiers on his tenants. Abolished in 1603.

Coyote (koi-ōt', koi-ō'tā), the American prairie-wolf (*Canis ochrōpus* or *Lyciscus latrans*).

Coypel (kwá-pel), NOËL, a French painter, born in 1628 or 1629, died in 1707 at Paris. He adorned the old Louvre and the Tuileries, and painted some fine pictures for the council-hall of Versailles. His son ANTOINE (1661-1721) was highly distinguished both as a painter and an engraver.

Coypou, COYPU (koi'pō), the native name of a South American rodent mammal, the *Myopotāmus coypus*, about the size of and considerably resembling a beaver. Its limbs are short, its tail in part bare and scaly, and it swims with great ease, its hind-feet being webbed. It inhabits burrows by the banks of streams. It is valued for its fur

(called *nutria fur*). Length when full grown, about 2 feet 6 inches.

Coysevox (kwás-vō), ANTOINE, French sculptor, born in 1640, died 1720. Among his best works are an equestrian statue of Louis XIV.; the statue of Cardinal Mazarin; the tomb of Colbert; the group of Castor and Pollux; the Sitting Venus; the Nymph of the Shell; the Hamadryad; the Faun with the Flute; Pegasus and Mercury.

Cozumel', an island in the Caribbean Sea, off the coast of Yucatan.

Crab, a popular name for all the ten-footed, short-tailed crustaceans constituting the sub-order Brachyura, order Decapoda, comprising many genera, distinguished from the lobster and other macrurous or long-tailed decapods by the shortness of their tail, which is folded under the body. The head and breast are united, forming the cephalothorax, and the whole is covered with a strong carapace. The mouth has several pairs of strong jaws, in addition to which the stomach has its internal surface studded with hard projections for the purpose of grinding the food. The stomach is popularly called the 'sand-bag'; a little behind it is the heart, which propels a colourless lymph (the blood) to the gills ('dead man's fingers'). The liver is the soft, rich yellow substance, usually called the *fat* of the crab. They 'moult' or throw off their calcareous covering periodically. The first pair of limbs are not used for locomotion, but are furnished with strong claws or pincers. Their eyes are compound, with hexagonal facets, and are pedunculated, elongated, and movable. Like most individuals of the class, they easily lose their claws, which are as readily renewed. They generally live on decaying animal matter, though others live on vegetable substances, as the racer-crabs of the West Indies, which suck the juice of the sugar-cane. Most inhabit the sea, others fresh water, some the land, only going to the sea to spawn. Of the crabs several species are highly esteemed as an article of food, and the fishery constitutes an important trade on many coasts. The common large edible crab (*Cancer pagurus*) is common on our shores, and is much sought after. See also *Hermít-crab*, *Land-crab*, *Pea-crab*.

Crab, a name given to various machines, especially to a kind of portable windlass or machine for raising weights, &c. Crabs are much used in building operations for raising stones or other weights, and in loading and discharging vessels.

CRAB-APPLE — CRAG AND TAIL.

Crab-apple (*Pyrus Malus*), a small, wild, very sour species of apple. See *Apple*.

Crabbe (krab), GEORGE, an English poet, born at Aldborough, Suffolk, 1754; died at Trowbridge, Wilts, 1832. Having been educated for the medical profession, he settled as a surgeon and apothecary in his native village, but soon finding his practice insufficient to afford him a livelihood, he resolved to try his fortune as littérateur in London. He obtained the friendship and assistance of Burke, published his poem the *Library*, and

soon after entered the church. He was appointed domestic chaplain to the Duke of Rutland, and afterwards obtained ample preferment. In 1783 appeared the *Village*, which was followed two years afterwards by the *Newspaper*. The *Parish Register* appeared in 1807. The *Borough* appeared in 1810, and was followed in 1812 by *Tales in Verse*, and in 1819 by *Tales of the Hall*. The latter years of Crabbe's life were spent in the peaceful discharge of his professional duties at Trowbridge in Wiltshire, a living which



The Cathedral, Cracow.

he had received in 1814. His poems are all characterized by homely truthfulness, simplicity, and pathos.

Cracklin, a species of chinaware which is ornamented by a net-work of small cracks in all directions. The ware receives the small cracks in the kiln, with the effect that the glaze or enamel which is afterwards applied appears to be cracked all over.

Cracovienne, a favourite dance of the Polish peasantry. The music is written in $\frac{2}{4}$ time.

Cracow, the old capital of Poland, in 1815-46 capital of a republic of the same name now forming part of Austrian Galicia, is situated on the left bank of the Vistula, where it becomes navigable, and consists of Cracow proper, or the old city, and several suburbs. It is the see of a bishop, is well built and regularly fortified. The cathedral, a fine old Gothic edifice, contains monuments of many Polish kings, of Kosciusko, &c. The university was founded

in 1364, but gradually fell into decay, and was reorganized in 1817. It has a library of 300,000 volumes. On a hill near the town stands the monument of Kosciusko, 120 feet high. Pop. 1891, 76,025 (20,000 being Jews).

Crag, in geol., a local name in England for shelly deposits in Norfolk and Suffolk, usually of gravel and sand, of the older pliocene period, subdivided into three members—viz. the Upper or *Mammaliferous Crag*, the *Red Crag*, and the Lower or *Coralline Crag*.

Crag and Tail, CRAIG AND TAIL, in geol., a name applied to a hill formation common in Britain, in which a bold and precipitous front is presented to the west or north-west, while the opposite side is formed of a sloping declivity. The rock on which Edinburgh Castle stands, with its 'tail' gradually sloping down to Holyrood, presents a fine example. This phenomenon is due probably

to the currents of the 'drift' or glacial epoch.

Craig, JOHN, Scottish reformer, born 1512, died 1600. He became Knox's colleague in Edinburgh, refused to publish the banns between Mary and Bothwell, assisted in drawing up the Second Book of Discipline, and compiled the National Covenant signed by the king in 1580.

Craig, SIR THOMAS, a Scottish writer on jurisprudence, was probably born in the year 1538, died 1608. He was educated at the University of St. Andrews, and afterwards repaired to France, where he studied civil and canon law. He returned about the year 1561, and was placed at the head of the criminal judicature of the country as justice depute. He is now chiefly remembered by his Treatise on Feudal Law.

Craik, DINAH MARIA, English novelist, born at Stoke-upon-Trent 1826, her father's name being Mulock. She became the wife of George Lillie Craik (a nephew of the subject of next article) in 1865. She published a volume of poems under the title of *Thirty Years*; many essays and papers on ethical and domestic subjects; books for young people, and about twenty-four novels, the best of which are: *John Halifax, Gentleman*; *A Life for a Life*; *Agatha's Husband*; and *The Woman's Kingdom*. She died in 1887.

Craik, GEORGE LILLIE, a miscellaneous writer, who was born in Fifeshire in 1799, and died at Belfast, June 25, 1866. He was an extensive contributor to the *Penny Cyclopædia* in the departments of history and biography. His first independent work of any importance was his *Pursuit of Knowledge under Difficulties* (1830-31). Other works were: *Romance of the Peerage*; *Spenser and his Poetry*; *History of Literature and Learning in England*, afterwards recast into *History of English Literature and the English Language*; *History of British Commerce*; *English of Shakspeare*; *Bacon, his Writings and Philosophy*; &c. In 1849 he was appointed professor of English literature in Queen's College, Belfast, an appointment which he held till his death.

Crail, a royal and parliamentary burgh and seaport of Scotland, in Fifeshire. It is a very ancient burgh, and has remains of a priory college and ruins of an old castle once a royal residence. Pop. 1145.

Crake. See *Corn-crake*.

Crambe, a genus of cruciferous plants, natives of Europe and Asia. They are per-

ennial herbs, with stout branched stems and broad leaves. One species, *C. maritima*, known as sea-kale, is a native of the sandy and shingly coasts of Britain.

Cramp, a variety of spasm, or sudden, involuntary, and painful contraction of a muscle or muscles. It is usually caused by sudden change of temperature, as in bathing, exposure to cold, over-exertion of the muscles, or the bringing into action muscles unaccustomed to exercise. See also *Writer's Cramp*.

Cranach, KRANACH (krá'náh), **LUCAS**, a German painter born in 1472, died in 1553. He was patronized by Frederick of Saxony, and accompanied him in his pilgrimage to Jerusalem. On the commencement of the Reformation movement he became the intimate friend of Luther and Melancthon, whose portraits, as taken by him, are among the most interesting memorials of the age. His works, chiefly portraits and historical subjects, are numerous and much prized. His son Lucas (d. 1586) also gained great distinction as a painter.

Cran'berry, the fruit of *Oxycoccus palustris*, nat. order Vacciniaceæ (whortleberries), a native of Europe, N. Asia, and N. America. It is also called *Moss-berry* or *Moor-berry*, as it grows only on peat-bogs or swampy land, usually among masses of sphagnum. The berry, when ripe, is globose and dark red, and a little more than $\frac{1}{4}$ inch in diameter. These berries form a sauce of exquisite flavour, and are used for tarts. The American cranberry, a native of Canada and the United States, is the *O. macrocarpus*. It has larger berries than the European species, and is extensively cultivated in some localities. *Vaccinium Vitis idæa*, the cow-berry, is often called the cranberry in Scotland.

Cran'brook, a small town of England, county Kent, 40 miles S.E. of London, where the first woollen manufactory in England was established by the Flemings in the reign of Edward III. Pop. 4216.

Crane, the common name of birds of the genus *Grus*, order Grallæ, or Grallatores. They are generally of considerable size, and remarkable for their long necks and stilt-like legs, which eminently fit them for living in marshes and situations subject to inundations, where they usually seek their food. This is partly of vegetable matter, but they also devour insects, worms, frogs, lizards, reptiles, small fish, and the spawn of various aquatic animals. They build their nests among bushes or upon tussocks in marshes;

CRANE — CRANK.

and lay but two eggs. Cranes annually migrate to distant regions, and perform voyages astonishing for their great length. The common crane (*Grus cineræa*) has the general plumage ash-gray, the throat black, the rump ornamented with long, stiff, and curled feathers, the head with bristly feathers; legs



Crowned Crane (*Balearica pavonina*).

black; length about 4 feet. It inhabits Europe, Asia, and the north of Africa. The crowned crane (*G. pavonina*, or *Balearica pavonina*) has the general plumage bluish ash-gray, the tail and primary quills black, the wing-coverts pure white; the head is crowned with a tuft of slender yellow feathers, which can be spread out at pleasure. It inhabits North and West Africa. The demoiselle crane (*Anthropoides virgo*) is so called from the elegance of its form. It is ash-gray, and the head is adorned with two tufts of feathers formed by a prolongation of the ear-coverts. Its habitat is Africa and the south of Europe. Among North American species are the whooping crane (*G. americana*), a larger species than the common crane, and the brown or sand-hill crane (*G. canadensis*).

Crane, a machine for raising great weights and depositing them at some distance from their original place, for example, raising bales from the hold of a ship and depositing them on the quay. Cranes are generally constructed on the principle of the wheel and axle, cog-wheel, or wheel and pinion. A very efficient wheel-and-pinion crane much used on quays consists of a jib or transverse beam, inclined to the vertical at an angle of from 40° to 50°, which, by means of a collar, turns on a vertical shaft. The upper end of the jib carries a fixed pulley, and the lower end a cylinder, which is put

in motion by a wheel and pinion. The weight is made fast to a rope or chain which passes over the pulley and is wound round the cylinder. On turning the cylinder (either by a winch handle attached to the wheel which works in the pinion, or by the application of steam-power) the weight is raised as far as necessary. The jib is then turned on its arbor till the weight is brought immediately over the spot where it is to be deposited, and the moving power is withdrawn so as to allow the weight to descend by its own gravity.

Crane, HYDRAULIC. See *Hydraulic Crane*.

Crane-fly, a genus of two-winged (dipterous) insects (*Tipula*), remarkable for the length of their legs. *Tipula oleracæa* is the well-known Daddy-long-legs, whose larva is very destructive to the roots of grain crops, &c.

Crane's-bill, the typical genus of the order Geraniaceæ. Many species are American plants; some are mere weeds, others extremely showy. See *Geranium*.

Cran'ganore, a town in Hindustan, presidency of Madras, state of Cochin, on the Malabar coast. Pop. 9475. It is the traditional field of St. Thomas' labours in India: Jews have been settled here since the 4th century; and it is certain the Syrian church was established before the 9th.

Craniol'ogy, the science which investigates the structure and capacity of the skull in various animals. It is sometimes also used as synonymous with *phrenology*. See *Phrenology*.

Cra'nium. See *Skull*.

Crank, an iron axis with the end bent like an elbow, serving as a handle for communicating circular motion; as, the *crank* of a grindstone; or for changing circular into

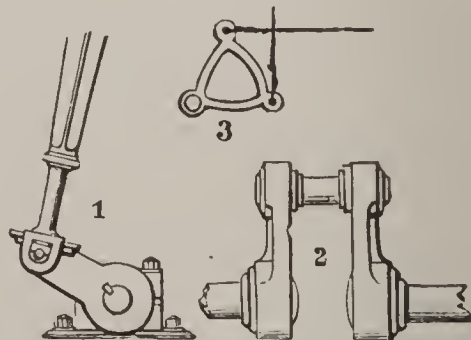

1, Single Crank. 2, Double Crank. 3, Bell Crank.

longitudinal motion, as in some saw-mills, or longitudinal into circular motion, as in a steam-engine. The single crank (1) can only be used on the end of an axis. The double

crank (2) is employed when it is necessary that the axis should be extended on both sides of the point at which the reciprocating motion is applied. An exemplification of this arrangement is afforded by the machinery of steam-boats. The bell-crank (3), so called from its being much used in bell-hanging, is for a totally different purpose to the others, being used merely to change the direction of motion, as from a horizontal to a vertical line.

Cran'ner, THOMAS, Archbishop of Canterbury, and famous for the part he played in the English reformation during the reign of Henry VIII., was born at Aslacton, Notts, in 1489; executed by burning at Oxford, 1556. He entered as a student of Jesus College, Cambridge, in 1503, took the degree of M.A., obtained a fellowship, and in 1523 was chosen reader of theological lectures in his college, and examiner of candidates for degrees in divinity. An opinion which he gave on the question of Henry VIII.'s proposed divorce from Catharine brought him under the favourable notice of the king. Cranmer was sent for to court, made a king's chaplain, and commanded to write a treatise on the subject of the divorce. In 1530 he was sent abroad with others to collect the opinions of the divines and canonists of France, Italy, and Germany, on the validity of the king's marriage. At Rome he presented his treatise to the pope, but his mission was fruitless. In January, 1533, he was appointed Archbishop of Canterbury. Soon after he set the Papal authority at defiance by pronouncing sentence of divorce between Henry and Catharine, and confirming the king's marriage with Anne Boleyn. The pope threatened excommunication, and an act of parliament was immediately passed for abolishing the pope's supremacy, and declaring the king chief head of the Church of England. The archbishop zealously promoted the cause of the Reformation: and through his means the Bible was translated and read in churches, and monastic institutions were vigorously suppressed. In 1536 he pandered to Henry's passions by promoting the divorce of Anne Boleyn. This and other services secured him in the king's favour, who appointed him by will one of the council of regency to Edward VI. By his instrumentality the liturgy was drawn up and established by act of parliament, and articles of religion were compiled, the validity of which was enforced by royal authority, and for which infallibility was

claimed. The exclusion of the Princess Mary from the crown, by the will of her brother, was a measure in which Cranmer joined the partisans of Lady Jane Grey, apparently in opposition to his own judgment. With others who had been most active in Lady Jane's favour he was sent to the Tower on the accession on Mary. He was tried on charges of blasphemy, perjury, incontinence, and heresy, and was sentenced to be degraded and deprived of office. After this flattering promises were made, which induced him to sign a recantation of his alleged errors, and become, in fact, a Catholic convert. But when he was brought into St. Mary's Church, Oxford, to read his recantation in public, instead of confessing the justness of his sentence, and submitting to it in silence or imploring mercy, he calmly acknowledged that the fear of death had made him belie his conscience; and declared that nothing could afford him consolation but the prospect of extenuating his guilt by encountering, as a Protestant penitent, with firmness and resignation, the fiery torments which awaited him. He was immediately hurried to the stake, where he behaved with the resolution of a martyr.

Cran'nogs, the name given in Ireland and Scotland to the platforms supported by piles in lakes, which were in use as dwelling-places and places of refuge among the old Celts. See *Lake Dwellings*.

Cran'tara (Gael. *crean-tarigh*, cross of shame, implying infamy for disobedience). See *Fiery Cross*.

Cranston, Providence co., R. I.; manufacturing town. Pop. 1890, 8099.

Crape, a light transparent stuff, like gauze, made of raw silk, gummed and twisted on the mill, woven without crossing, and much used in mourning.

Cra'shaw, RICHARD, an English poet, born in London 1613, died 1649; educated at the Charterhouse and at Cambridge. In 1637 he became a fellow of Peterhouse, and having been admitted to orders was noted as an eloquent and powerful preacher. In 1644 he was ejected from his fellowship by the Parliamentarians, and proceeded to Paris, where he became a convert to the Roman Catholic faith, and was appointed to a canonry at Loretto. *Epigrammata Sacra* appeared in 1634; *Steps to the Temple*, Sacred Poems, with other Delights of the Muses, was published in London in 1646; and a posthumous volume appeared at Paris in 1652, under the title *Carmen Deo Nostro*.

Crashaw displays considerable poetic genius in the treatment of religious subjects, and though his works are now almost forgotten they are said to have furnished hints to both Milton and Pope.

Crassula'ceæ, the house-leek family, a nat. order of polypetalous exogens. It consists of succulent plants, with herbaceous or shrubby stems, and annual or perennial roots, growing in hot, dry, exposed places in the more temperate parts of the world, but chiefly South Africa. Many species of *Crassula*, *Sempervivum*, *Sedum*, &c., are cultivated in green-houses for the beauty of their flowers. The genus *Sedum* is the most largely represented in the U. S.

Crassus, MARCUS LICINIUS, the Roman triumvir, surnamed *Dives* (the rich), on account of his vast riches, was born about B.C. 115, died B.C. 53. He took part with Sulla in the civil war; and as prætor, in B.C. 71, he defeated Spartacus and the revolted slaves at Rhegium. In B.C. 70 he was elected consul, having Pompey as his colleague; and in B.C. 60 Cæsar, Pompey, and Crassus formed the first triumvirate. Five years later he again became consul, and obtaining Syria for his province he made war on the Parthians, but was defeated and slain. It is said that when his head was sent to Orodes, the Parthian king, he caused melted gold to be poured into the mouth, in scorn of his notorious love of wealth.

Cratægus, the hawthorn genus.

Crater, the orifice or mouth of a volcano. Craters may be central or lateral, and there may be several subsidiary ones, which may shift their places, or become merged by subsidence into others.

Crati'nus, an Athenian comic poet to whom the invention of satirical comedy is attributed; died B.C. 422 at the age of 97. Some fragments of his works remain.

Cravat', a neckcloth; an article of silk, muslin, or other material worn by men about the neck; so called from Fr. *Cravate*, a Croat, because this piece of dress was adopted in the 17th century from the Croats who entered the French service. Towards the end of the 18th and the beginning of the 19th century the cravat attained an incredible degree of extravagance, but common sense at last brought in the simpler style of neck-ties that has since prevailed.

Crawfish, or CRAYFISH, a name of various crustaceous animals, the common crawfish being *Astacus fluviatilis*, the river lobster, a macrurous (long-tailed), ten-footed crus-

tacean, resembling the lobster in appearance and habits. It inhabits the fresh waters of Europe and the north of Asia, and is common in some of the streams of England. It lurks under stones or in holes in the banks. Its food consists of small molluscs or fishes, the larvæ of insects, and almost any sort of animal matter. In the U. States crawfish of the genus *Astacus* and *Cambarus* occur. Some of them by their burrowing habits injure mill-dams and the levees of the Mississippi.

Crawfordville, Montgomery co., Ind., 43 miles w. of Indianapolis. Pop. 1890, 6086.

Crawford, THOMAS, sculptor, was born in New York city, March 22, 1814. His most famous works comprise "Orpheus and Cerberus," "Adam and Eve," "Hebe and Ganymede," "Mercury and Psyche," and "Dancing Jenny." He performed important works for the National Government and State of Virginia. He died in 1857.

Cray'ons, coloured pencils obtained from certain mineral substances in their natural state, but more commonly manufactured from a fine paste of chalk or pipe-clay coloured with various pigments, and consolidated by means of gum, wax, &c. A kind of *crayon painting* (or *pastel painting*) is practised to some extent, the colouring matter in a soft state being rubbed on with the finger. Its chief advantages consist in the great facility of its execution, and the soft beauty and richness of colouring of effects so easily produced. The paper used has a specially granulated surface.

Cream, the yellowish, thick, oily layer which forms at the surface when new milk is allowed to remain at rest. When it is agitated or churned butter is formed.

Cream of Tartar, or POTASSIUM BITARTRATE ($KH C_4H_4O_6$), exists in grapes, tamarinds, and other foods. It is prepared from the crystalline crust (crude tartar or argol) deposited on the vessels in which grape juice has been fermented. The argol is dissolved by boiling with water, the mixture filtered, and the cream of tartar allowed to crystallize out. The commercial product usually contains a small percentage of calcium tartrate. It is frequently employed in medicine for its diuretic, cathartic, and refrigerant properties; as a mordant in dyeing wool; and as an ingredient in baking-powder.

Cre'asote, a substance discovered by Reichenbach about 1831 in wood-tar, from which it is separated by a tedious process. It is generally obtained, however, from the pro-

CREASY — CRECY.

ducts of the destructive distillation of wood. In a pure state it is oily, heavy, colourless, has a sweetish burning taste and a strong smell of peat smoke or smoked meat. It is a powerful antiseptic. Wood treated with it is not subject to dry-rot or other disease. It has been used in surgery and medicine with great success.

Creasy (krē'si), SIR EDWARD SHEPHERD, English historian, was born at Bexley, Kent,

in 1812, died 1878. He was educated at Eton, and at King's College, Cambridge, of which he was elected a fellow in 1834. He was called to the bar at Lincoln's Inn in 1837, and was for about twenty years a member of the home circuit. In 1840 he was appointed professor of history at the London University, and in 1860 was made Chief-justice of Ceylon, receiving at the same time the honour of knighthood. His principal



Battlefield and Old Windmill of Crécy. From drawing on the spot by John Absolon.

works are: *The Rise and Progress of the British Constitution*, and *The Fifteen Decisive Battles of the World*.

Creationism, the doctrine that a soul is specially created for each human fœtus as soon as it is formed in the womb: opposed to *Traducianism*, which teaches that the souls of children as well as their bodies are begotten by reproduction from the substance of the parents; and to *Infusionism*, which holds that souls are pre-existent, and that a soul is divinely infused into each human fœtus as soon as it is formed by generation. Many theologians, however, regard the mode of the soul's coming into being as a part of the mystery which envelops the whole subject of the existence and transmission of life. The term *Creationism* has also recently been applied to that theory of the origin of man which is opposed to Evolution.

Crébillon (krā-bē-yōn), PROSPER JOLYOT DE, a French writer of tragedy, was born at Dijon 1674, died 1762. His first play, *La Mort des Enfants de Brutus*, was rejected

by the actors; but his next productions, *Idoménée* (1705) and *Atrée* (1707), were successful. These were followed by *Rhadamiste* (1711), *Xerxes* (1714), and *Semiramis* (1717). At the age of seventy-six he wrote the *Triumvirate*, or the *Death of Cicero*, which was brought upon the stage in his eighty-first year. — His son CLAUDE PROSPER, born 1707, died 1797, was in high repute for his wit and his writings. His chief works are: *Le Sopha*, *La Hazard du Coin du Feu*, and *Les Égarements du Cœur et de l'Esprit*, all of a licentious cast.

Crèche (krāsh), a public nursery for the children of poor women who have to work out during the day, where for a small payment they are nursed and fed during the day, remaining with their parents at night. These institutions were first started in Paris in 1844; they were soon afterwards introduced into Great Britain, and are now common in large towns.

Crécy, or CRESSY, a small town of France, in the department of Somme, 9 miles north

of Abbeville and 100 north of Paris; pop. 1748. It is celebrated on account of a battle fought here, August 26, 1346, between the English and French. Edward III. and his son, the Black Prince, were both engaged, and the French were defeated with great slaughter, 30,000 foot and 1200 horse being left dead on the field; among whom were the King of Bohemia, the Count of Alençon, Louis, count of Flanders, with many others of the French nobility.

Cre'dence, a small table by the side of the altar or communion-table, on which the bread and wine are placed before they are consecrated.

Cred'it, in economics, is the postponement agreed on by the parties of the payment of a debt to a future day. It implies confidence of the creditor in the debtor; and a 'credit system' is one of general confidence of people in each other's honesty, solvency, and resources. By means of a credit system a comparatively small stock of money can be made to do duty for carrying on a number of different transactions; but it is indispensable for every good system of credit that money must be instantly available when required, and this principle applies to every species of transaction where postponed payment is concerned. Public credit is the confidence which men entertain in the ability and disposition of a nation to make good its engagements with its creditors; or the estimation in which individuals hold the public promises of payment, whether such promises are expressed or implied. The term is also applied to the general credit of individuals in a nation; when merchants and others are wealthy and punctual in fulfilling engagements; or when they transact business with honour and fidelity; or when transfers of property are made with ease. So we speak of the credit of a bank when general confidence is placed in its ability to redeem its notes, and the credit of a mercantile house rests on its supposed ability and probity, which induce men to trust to its engagements. When the public credit is questionable it raises the premium on loans.

Credit, **LETTER OF**, an order given by bankers or others at one place to enable a person to receive money from their agents at another place.

Crédit Foncier (krā-dē foŋ-syā), a peculiar mode of raising money on land in France, the peculiarity of which is that the advance must not exceed one-half of the

value of the property pledged or hypothecated, and that the repayment of the loan is by an annuity terminable at a certain date. Several companies have been established by the French government with the privilege of making such loans.

Crédit Mobilier (krā-dē mō-bēl-yā), a scheme which originated in France in 1852, its objects being to undertake trading enterprises of all kinds on the principle of limited liability, to buy up existing trading companies, and to carry on the business of bankers and stock-jobbers.—**CREDIT MOBILIER OF AMERICA**, chartered in Pennsylvania, U. States, in 1859, for a general loan and contract business; organized in 1863, capital \$2,500,000; the charter purchased in 1867 by a company formed for the construction of the Union Pacific R. R. A congressional investigation showed that a number of congressmen were private owners of the stock. As the railroad had been assisted by grants of land by congress it was considered highly improper for members to have a pecuniary interest in such a concern. The expulsion of one senator was recommended, and two representatives were censured.

Creed, a summary of belief, from the Latin *credo* (I believe), with which the Apostles' and Nicene Creeds begin. These two creeds, together with the Athanasian Creed, are the most ancient authoritative Christian creeds, though numerous ancient formularies of faith are preserved in the writings of the early fathers, Irenæus, Origen, Tertullian, &c., which agree in substance, though with some diversity of expression. The Nicene Creed was so called from being adopted as the creed of the church at the Council of Nicæa or Nice, 325 A.D., though its terms were subsequently somewhat altered. The Apostles' Creed probably dates from the end of the 4th century; but there is no evidence of its being accepted in its present form till the middle of the 8th. The Athanasian Creed was certainly not drawn up by St. Athanasius, as there is no sufficient evidence for its existence before the end of the 8th or beginning of the 9th century. In addition to these three creeds, the R. C. Church has the creed of Pius IV., put forth in 1564, and consisting of the Nicene Creed with additional articles adopted by the Council of Trent, to which is now added a profession of belief in the definitions of the Vatican Council. The English Church adopts as

'thoroughly to be received and believed' the three ancient creeds, which as part of her liturgy may be read in the Book of Common Prayer, but does not consider any of them to be inspired. Besides these creeds, there are numerous Confessions of Faith, which have been adopted by different churches and sects. The Thirty-nine Articles of the Book of Common Prayer form a confession of faith for the Anglican Church. The creed of the Church of Scotland and other Presbyterian churches is contained in the Confession of Faith, drawn up by the Westminster Assembly of Divines, and completed in 1646.

Creedmoor, a station on the Long Island railway, 11 miles east of the city of New York. It is much frequented by riflemen for target practice.

Creek, a small inlet, bay, or cove; a recess in the shore of the sea or of a river. In America and Australia the term is often applied to a small river or rivulet.

Creeks, American Indians formerly in Georgia and Alabama, but now planted in the Indian Territory. The number of warriors used to amount to about 6000, but altogether the tribe does not now exceed 9300. They have made considerable progress in agriculture, and raise horses, cattle, fowls, and hogs, and cultivate tobacco, rice, and corn.

Creepers, a family (*Certhiadae*) of birds which strongly resemble the woodpeckers in their habit of creeping on the stems of trees with the aid of the strong quills which project from the tail-feathers, and of securing their insect food by an exsertile tongue. The common creeper (*Certhia familiaris*) is European, but is represented by American species. It is a pretty and interesting little bird, which builds its nest usually in holes or crevices of trees. The wall-creeper (*Tichodroma muraria*) of Southern Europe searches for its insect food on rocks. The family is found in all parts of the world.

Crefeld. See *Krefeld*.

Crema, a fortified city of Northern Italy, province Cremona, on the Serio, 25 miles E.S.E. of Milan; pop. 9200. It contains a cathedral, picture-gallery, &c.

Crema'tion, the burning of the bodies of the dead, a practice which was frequent in ancient times instead of burial, and which has recently been advocated on hygienic grounds by many scientific men in Europe and America on account of the dangers to the living caused by the presence of grave-

yards and cemeteries. Various methods of cremation have been proposed, the great difficulty being to consume the body without permitting the escape of noxious exhalations, and without mingling the ashes with foreign substances. In Siemens' process, a modification of a plan of Sir Henry Thompson, this is successfully accomplished. Cremation societies have been instituted in every European country, and in many of the American States.

Cremnitz. See *Kremnitz*.

Cremona, a city of Italy, capital of province of same name, on the left bank of the Po, 47 miles S.E. by E. Milan. It is surrounded by walls and wet ditches, its circumference being nearly five miles. The most remarkable edifice is the cathedral, begun in 1107 and completed about 1491. Close by, and connected with the cathedral, is the Torazzo, one of the loftiest and most beautiful towers in Italy. Cremona is the seat of a bishopric, and has considerable manufactures of silk, wool, cotton, &c. It was at one time celebrated for its violins, especially those made by Antonius Stradivarius, Joseph Guarnerius, and members of the Amati family. Pop. 31,788. The province has an area of 695 sq. miles, and a population, 1891, of 305,557.

Crenelle (*krè-nel'*), an embrasure in an embattled parapet or breastwork. The adjective *crenellated* is applied in architecture to a kind of embattled or indented moulding of frequent occurrence in buildings of the Norman style.

Cre'ole (Spanish, *criollo*) is the name which was originally given to all the descendants of Spaniards born in America and the West Indies. It is now used in a wider sense to signify the descendants of Europeans of any nation born in South America and the West Indies, as well as in some other localities. *Creole dialects* are those jargons which have originated from the mixture of different languages in the West Indies, Southern United States, &c., and are spoken by the descendants of the slaves. According to the European language which prevails in a Creole dialect it is called *French Creole*, *Spanish Creole*, &c.

Creosote. See *Creasote*.

Crescendo (*kre-shen'dō*), or **CRES.** (Italian), a musical term signifying that the notes of the passage over which it is placed are to be gradually swelled. Crescendo passages are marked \langle signifying piano to forte; the corresponding mark \rangle dimi-

nuendo, marking the transition from forte to piano.

Cres'cent (Lat. *crescens*, growing), an emblem representing the moon in her horned state. This emblem is of very high antiquity, being that of the Greek goddess Artemis or Diana. It is found on medals of many ancient cities, particularly of Byzantium, from whence it is supposed to have been borrowed by the Ottomans. Since their establishment in Europe it has been the universal emblem of their empire. The crescent has given name to a Turkish order of knighthood from the form of the badge, instituted by Selim, sultan of Turkey, in 1801.

Crescentia'ceæ, a small family of corollifloral dicotyledons, of which the genus *Crescentia*, the calabash-tree, is the type.

Crespi, GIUSEPPE MARIA, Italian painter of the Bolognese school, born at Bologna in 1665, died 1747. He had many scholars, among whom were his two sons Antonio and Luigi Crespi. The latter distinguished himself by his writings on painting. Crespi is also known as an engraver.

Cress, the name of several species of plants, most of them of the nat. order Cruciferæ. Water-cress, or *Nasturtium officinæle*, is used as a salad, and is valued in medicine for its antiscorbutic qualities. The leaves have a moderately pungent taste. It grows on the brinks of rivulets and in moist grounds. Common garden cress is the *Lepidium sativum*; Normandy cress, *Barbarea præcox*; winter cress, *B. vulgâris*; Indian cress, *Tropæolum majus*; bitter cress, *Cardamine pratensis* (cuckoo-flower).

Cresselle (kre-sel'; Fr. *crecelle*), a wooden rattle used in some Roman Catholic countries during Passion Week instead of bells, to give notice of divine worship.

Cresset, a name which appears to have

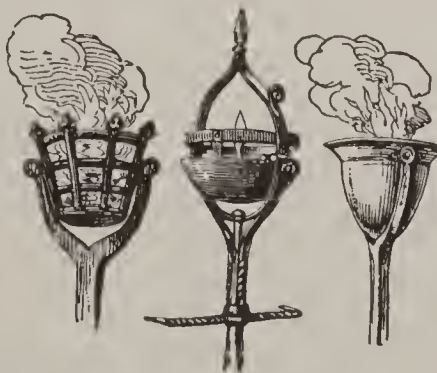

Various forms of Cressets.

been given in the middle ages and later indifferently to the fixed candlesticks in great

halls and churches, to the great lights used as beacons and otherwise, and to lamps or fire-pans suspended on pivots and carried on poles in processions, municipal and military watches, &c.

Cressy. See *Crécy*.

Crest (Latin, *crista*), in anc. armour, the plume or tuft of feathers, or the like, affixed to the top of the helmet. In her. the crest is a figure originally intended to represent the ornament of the helmet, but is now generally placed upon a wreath, coronet, or cap of maintenance, above both helmet and shield. The crest is considered a greater criterion of nobility than the coat of arms itself, and it is now commonly a piece of the arms.



Crest on a wreath.

Creston, Union co., Iowa. Pop. 7200.

Creswick (kres'ik), THOMAS, English landscape-painter, born 1811, died 1869. He was elected an associate of the Royal Academy in 1842, and R.A. in 1851. His first pictures were admitted into the Academy exhibition when he was only in his seventeenth year, and his success was afterwards continuous. Among his great works are England, London Road a Hundred Years Ago, and the Weald of Kent.

Creta'ceous (or CHALK) **System**, in geol. the upper strata of the Secondary series, immediately below the Tertiary series, and superincumbent on the Oolite system. This group is common to Europe, and also to a part of Asia. It consists of chalk resting upon arenaceous and argillaceous deposits, which are also regarded as part of the system. It has been divided into two parts—the *Upper*, consisting entirely of chalk or marl, and subdivided into the *upper* or *soft chalk*, containing many flint and chert nodules; the *lower* or *harder chalk*, with fewer flints; and the *chalk marl*: and the *Lower*, consisting of sands and clay, and subdivided into the *upper greensand*; *gault*, a bluish tenacious clay; and the *lower greensand*. Palæontologists have suggested another division founded on the fossil remains found in the system, in accordance with which the upper greensand and gault are transferred to the upper series, and the lower greensand and Wealden beds and Hastings sands constitute the lower.

Crete. See *Candia*.

Cret'inism, a form of idiocy associated with a peculiar condition of the body, oc-

curing in Switzerland and other mountainous countries. Cretins are usually affected with goitre, and are usually the offspring of goitrous parents. They are ill grown and stunted, with swollen bellies. The skin is coarse, head large, the nose sunken and flattened at the bridge, the lips thick, chin protruding, mouth wide and gaping, the tongue large. The countenance is dull and heavy; there is general muscular weakness and slowness of sensibility. Associated with these are feebleness or want of intellect, varying in degree from absolute vacuity to a certain power of acquiring a little knowledge; sometimes deafness and dumbness, perhaps squinting and blindness. Careful training may do much for them, along with good food, cleanliness, exercise, &c.

Cretonne (kre-ton'), a cotton cloth with various textures of surface, printed on one side with pictorial and other patterns, and used for curtains, covering furniture, &c.

Creuse (kreuz), an inland department, France, comprising most part of the old province of Marche; area, 2150 square miles. It derives its name from the river Creuse, which rises in it, and traverses it diagonally in a north-west direction, afterwards flowing on to join the Vienne. The surface is generally rugged, and the soil, which is thin and rests upon granitic rocks, is by no means fertile. Pop. 284,942.

Creuzer (kroi'tsér), GEORG FRIEDRICH, German philologist and archæologist, born 1771, died 1858. For nearly forty-five years he filled the chair of philology and ancient history at Heidelberg. He wrote on the mythology of Greece and other nations, on Greek history and literature, Roman antiquities, &c.

Creuzot (kreu-zō), LE, a town of Eastern France, dep. Saône-et-Loire, 14 miles from Autun, with extensive iron-works, the most complete in France. The mining of coals, the smelting of iron, and the manufacture of machinery give employment to about 15,000 workmen in the town and vicinity, the greater number belonging to the works of Schneider & Co. Pop. 17,371.

Crewe (krö), a municipal town of England, in Cheshire, 21 miles S.E. Chester, an important railway centre and the seat of enormous manufactories of railway plant. It is quite a modern town, well laid out, and chiefly inhabited by people connected with the railways. It has a commodious market-hall, a corn exchange, mechanics' institution, town-hall, &c. Pop. 24,385.

Crewel-work (krö'el), work executed with the needle, and consisting of designs sewed in coloured silk or woollen threads on a basis of unbleached cotton or linen, towelling, or the like.

Crewkerne (krö'kèrn), a town of England, in Somersetshire, 16 miles south-east of Taunton; manufactures sail-cloth. Pop. 3982.

Crib'bage, a favourite English game at cards played with the whole pack. It may be played by two, three, or four persons; and when by two, five or six cards may be dealt to each. Five-card cribbage played by two persons is the most scientific game. Sixty-one-points make the game; there are no tricks and no trumps, the object being to make *pairs, fifteens, sequences*, or the *go*, or prevent the adversary from doing the same. Court cards and tens count as ten each, and all the rest count for the number of 'pips' upon them. Every *pair*, that is, every couple of cards of the same value belonging to different suits (two aces, two fours, two kings, &c.), counts two; and when there are three or four similar cards, as many pairs are counted as there are different combinations of the cards taken two at a time. Every combination of cards, the united pips of which make up fifteen, counts two. A sequence consists of three or more cards of any suit following one another in rank, and counts one for each card. When the player whose turn it is to play cannot play a card without going beyond thirty-one, the other player scores one for having been the nearest to thirty-one. This is called scoring one for 'the go.' The remaining cards after thirty-one, or the next point to it, is made, are thrown up, and each player's cards are counted. When all the cards in a hand, either with or without the turn-up card, are of one suit, or when all the cards in the *crib*, with the turn-up card, are of one suit, it is called a *flush*, and counts one for each card. When the turn-up card is a knave the dealer scores two ('two for his heels'). When a knave of the same suit with the turn-up card is found in the hand of either player, the player in whose hand it is scores one ('one for his nob').

Crichton (kri'ton), JAMES, surnamed the *Admirable*, a Scottish celebrity, son of Robert Crichton, lord-advocate, was born in 1560, died about 1585. He was educated at the University of St. Andrews, and according to the current accounts of him, before his twentieth year, had run through the whole

circle of the sciences, could speak and write to perfection ten different languages, and was equally distinguished for his skill in riding, fencing, singing, and playing upon all sorts of instruments. He visited Paris, Genoa, Venice, Padua, &c., challenging all scholars to learned disputations, vanquishing doctors of the universities, and disarming the most famous swordsmen of the time in fencing. He was latterly tutor to a son of the Duke of Mantua, and is said to have been stabbed to the heart in a dastardly manner by his pupil. The story of his achievements seems to be rather highly coloured; but he was extravagantly praised by Aldus Manutius, the printer of Venice, by whom he was well known. He left some Latin poems, which are said to be possessed of no remarkable quality.

Cricket, an insect of the genus *Gryllus*, or *Achēta* of some naturalists, order Orthoptera. There are several species. The house-cricket is the *Achēta (Gryllus) domestica*; the field-cricket is the *Achēta (Gryllus) campestris*; the mole-cricket is the *Gryllotalpa vulgāris*. The house-cricket of Europe is about an inch long, with antennæ of about an inch and a half, of a pale yellowish colour mixed with brown. By the friction of the peculiarly-formed wing-covers the males produce that stridulous sound by which these insects are so well known, and which has become associated with ideas of cheerful domestic comfort. They live in holes and crevices near fire places or in other warm situations, whence they come out at night to feed on crumbs and other fragments of food. The field-cricket makes a similar noise. The house-cricket has been introduced into the U. States, and there are several species of field-cricket there also. See also *Mole-cricket*.

Cricket, a favourite open-air game played with bats, balls, and wickets on a piece of smooth green sward. It is played by two opposite sets or sides of players, generally numbering eleven each. Two *wickets* of three *stumps* each are pitched fronting each other at a distance of about 22 yards apart, the stumps being upright rods stuck in the ground, and projecting 27 inches. On the top of each set of stumps are placed two small pieces of wood called *bails*. After the rival sides have tossed for the choice of either taking the bat or fielding, two men are sent to the wickets bat in hand. The opposite or fielding side are all simultaneously engaged; one (the bowler) being stationed

behind one wicket for the purpose of bowling his ball against the opposite wicket, where his coadjutor (the wicket-keeper) stands ready to catch the ball should it pass near him; the other fielders are placed in such parts of the field as is judged most favourable for stopping the ball after it has been struck by the batsman or missed by the wicket-keeper. It is the object of the batsman to prevent the ball delivered by the bowler reaching his wicket either by merely stopping it with his bat or by driving it away to a distant part of the field. Should the ball be driven any distance the two batsmen run across and exchange wickets, and continue to do so as long as there is no risk in being 'run out,' that is, of having the stumps struck by the ball while they are out of their position near the wickets. Each time the batsmen run between the wickets is counted as a 'run,' and is marked to the credit of the striker of the ball. If the batsman allows the ball to carry away a bail or a stump, if he knocks down any part of his own wicket, if any part of his person stops a ball that would have otherwise reached his wicket, or if he strikes a ball so that it is caught by one of the opposite party before it reaches the ground, he is 'out,' that is, he gives up his bat to one of his own side; and so the game goes on until all the men on one side have played and been put out. This constitutes what is called an 'innings.' The other side now take the bat and try to defend their wickets and make runs as their rivals did. Generally after two innings each have been played by the contestants the game comes to an end, that side being the victors who can score the greatest number of runs.

Cricklade', a town of England, county Wilts, 42 miles north of Salisbury; pop. 1600. Until 1885 it returned two members to parliament, but the parliamentary borough included between forty and fifty parishes. Cricklade now gives name to the northern parliamentary division of Wiltshire.

Crieff (krēf), a town of Scotland, county Perth, beautifully situated on a slope above the Earn, backed by lofty hills and crags. The principal manufacture is woollens (shirtings, blankets, tweeds, &c.). The environs of Crieff are singularly beautiful, and its climate salubrious. Pop. 4469.

Crillon (krē-yōn), LOUIS DES BALBES DE BERTON DE, great French warrior of the 16th century, born in 1541, died 1615. He distinguished himself in five successive reigns

—those of Henry II., Francis II., Charles IX., Henry III., and, above all, in that of Henry IV. He distinguished himself at the capture of Calais, and in the battles of Dreux, Jarnac, and Moncontour (1569), against the Huguenots, and in the naval battle of Lepanto against the Turks. The massacre of St. Bartholomew was reprobated by him. He fought for Henry at Ivry against the Catholic League.

Crime, a term used to indicate sometimes a violation of the higher moral law, sometimes more specifically the violation of a certain group of the laws formulated by a nation. This group properly comprises in its scheme all offences endangering the welfare of the community, as distinct from civil or private injuries, which are as between person and person, and terminate with the compensation of the injured. Hence from the legal point of view crime is sometimes defined as an offence punishable by law directly, as opposed to an offence which the law punishes indirectly by granting damages to the person wronged. (See *Criminal Law*.) Whether used in the legal or the moral sense crime implies freedom of will, the power of distinguishing between right and wrong, and a fulfilled intention. Hence, though the theoretic rule of common law is that all infraction of law is criminal and penal, it is held that young children, madmen, and idiots cannot commit crimes.

Crime'a, THE (anc. *Chersonēsus Taurica*), a peninsula of Southern Russia, government of Taurida, to the mainland of which it is attached by the Isthmus of Perekop; area, 10,000 sq. miles. On the west and south it is washed by the Black Sea, and on the east by the Sea of Azof, a portion of which, shut off from the rest by a long and narrow strip of land, forms the Sivash or Putrid Sea. Three-fourths of the Crimea belongs to the region of steppes, but the other part, confined entirely to the south, and stretching along the coast from west to east, abounds in beautiful mountain scenery. Here the valleys looking southward are luxuriant with vines and olive and mulberry plantations, while the northern slope gives a large yield in cereals and fruits. The climate, however, is unequal, and in winter is severe. The chief stream is the Salghir. Others of celebrity are the Tchernaya and the Alma. The most important of the productions, besides those already mentioned, are tobacco, of which a large quantity of excellent quality is produced, flax and hemp. The forests are

of limited extent. There are large numbers of fine-woolled sheep, and horned cattle and horses are reared in large numbers. Pop. estim. at 450,000. The chief town and port is Sebastopol. The country was anciently associated with the Cimmerians, and in later times with various Greek settlements and minor kingdoms. After being for some time a dependency on Rome, it was overrun by successive bodies of barbarians, and in 1237 fell into the hands of the Mongols under Genghis Khan. About 1261 the Genoese were permitted to occupy and fortify Kaffa, and they rapidly extended their power in the formation of other settlements. They were expelled, however, in 1475 by Mahomet II., who made it a dependent khanate. In 1783 the Russians took possession of the country; and with the view of overawing the Turks the great naval arsenal of Sebastopol, occupying the most commanding position in the Black Sea, was begun by Catharine II. in 1786. Its military resources were steadily developed up to the time of the Anglo-French campaign (see *Crimean War*) of 1854, when it fell into the hands of the allies.

Crime'an War, the struggle between England, France, and Turkey on the one hand, and Russia on the other, to prevent the undue preponderance of Russia in the east of Europe; 1854 to 1856. The old plans for the extension of Russian power conceived by Catharine II. and Potemkin were resuscitated by Nicholas I., who, believing that he had secured himself from interference on the part of Austria and Prussia, and that an Anglo-French alliance was impossible, prepared to carry them into action. Servia, Bosnia, Bulgaria, and the principalities of the Danube were to become Russian protectorates, and Constantinople was to be provisionally occupied by Russian troops. The first markedly aggressive step—the demand by Russia for a protectorate over the Greek Church throughout the Turkish empire—brought matters to a crisis. An ultimatum presented by Menschikoff in May 1853 was rejected by the Porte; the Russians occupied the Danubian principalities; and war was declared by the Porte in October, 1853, by France and England in 1854, and by Sardinia in 1855. A French and English fleet entered the Baltic and captured Bomarsund and one of the Aland Islands, and in the south the allies landed at Varna, under Lord Raglan and Marshal St. Arnaud as commanders-in-chief. While

CRIMINAL LAW.

the allies were making preparations Prussia and Austria demanded the evacuation of the Danubian principalities, and on evacuation being ordered by Nicholas, 'for strategic reasons,' the principalities were provisionally occupied by the Austrians. It soon became obvious that the Crimea must be the seat of the war, and 50,000 French and English troops with 6000 Turks were landed at Eupatoria (Sept. 1854). Five days later the battle of Alma was won by the allies (20th Sept.), and the march continued towards the south side of Sebastopol. Soon after St. Arnaud died and was succeeded by Canrobert. The siege of Sebastopol was commenced by a grand attack which proved a failure, and the Russians under Liprandi retaliated by attacking the English at Bala-klava (Oct. 25), but were defeated with heavy loss. It was at this battle that the famous, but useless, charge was made by the Light Brigade. A second attack at Inkerman was again repulsed by the allies, but the siege works made slow progress during the winter, in which the ill-supplied troops suffered great privations. The death of Nicholas and succession of Alexander II., in March, 1855, brought no change of policy. Canrobert resigned in favour of Pélissier; and shortly after an unsuccessful attack on those parts of the fortifications known as the Malakhoff and Redan Lord Raglan died, and was succeeded by Simpson. The bombardment was continued, and in September the French successfully stormed the Malakhoff, the simultaneous attack on the Redan by the British proving a failure. The Russians, however, then withdrew from the city to the north forts and the allies took possession. The chief subsequent event was the capture of Kars, in Asia, by the Russians after a splendid defence by the Turks under General Williams. By this time, however, the allies had practical possession of the Crimea, and overtures of peace were gladly accepted. A treaty was accordingly concluded at Paris on 27th April, 1856, by which the independence of the Ottoman Empire was guaranteed. See *Paris, Treaty of*.

Criminal Law, the law relating to crimes. The general theory of the common law is, that all wrongs are divisible into two species: first, civil or private wrongs or *torts*; secondly, criminal or public wrongs. The former are to be redressed by private suits or remedies instituted by the parties injured. The latter are redressed by the

state acting in its sovereign capacity. The general description of the private wrongs is, that they comprehend those injuries which affect the rights and property of the individual, and terminate there; that of public wrongs or offences being, that they comprehend such acts as injure, not merely individuals, but the community at large, by endangering the peace, the comfort, the good order, the policy, and even the existence of society. In the first, therefore, so far as the law is concerned, the compensation of the individual whose rights have been infringed is held to be a sufficient atonement; but in the second class of offences it is demanded that the offender make satisfaction to the community as acting prejudicially to its welfare. The exact boundaries between these classes are not, however, always easy to be discerned, even in theory; for there are few private wrongs which do not exert an influence beyond the individual whom they directly injure. The divisions, torts and crimes, are thus not necessarily mutually exclusive, cases sometimes occurring in which the person injured obtains damages, while at the same time the criminal is subjected to punishment, not as against the individual, but as against the state. It is, moreover, obvious that legal criminality is not in any strict sense the measure of the morality of actions, though the legal enactment tends to enforce itself as a moral law. In large part it is only an approximate expression of the current sense of justice, this expression being both aided and hindered by the historical and constantly reflexive character of legal method. The basis of the criminal law of Great Britain is to be found in a series of loose definitions and descriptions, of which many, and those among the more important, date from the 13th century. The irregular superstructure reared upon these consists mainly of parliamentary enactments which originated in the 18th century, but have been twice re-enacted in the present century—the first time between 1826 and 1832, and the second time in 1861, with an intermediary attempt at amendment in 1837. The laws as formulated, however, by no means always represent the law as interpreted, the whole system being further complicated by a mass of judicial comments and particular constructions. Thus while there is a statutory division of crimes into treasons, felonies, and misdemeanours, the distinctions between them are so uncertain that it is possible to regard the first head as merely

the isolation of a sub-case of felony; while in respect of the second and third classes, the distinction can only be clearly marked by an enumeration of the crimes arbitrarily assigned to each in the common law and judges' decisions. Even in severity of punishment a misdemeanour may rank as high as a felony. The Criminal Statutes Consolidation Acts—the result of a series of commissions extending over thirty years—accomplished little more in the way of systematization than the introduction of greater exactitude into the definition of certain individual offences and the gradation of penalties. The aim of criminal law as at present constituted is both retributive and preventive—in its former aspect being based upon the primitive passion of retaliation, in the latter primarily upon the fundamental instinct of self-preservation. The prevention of crime may, however, be effected in a threefold manner: by imposing a penalty which shall operate by fear to deter men from committing crimes, or by rendering it physically impossible for a man of known criminal tendency to repeat an offence, or by the reformation of the criminal. With the higher evolution of society the principle of retaliation has fallen into theoretic disrepute, though still a practical legal factor; and the problems of penology are made to turn almost exclusively upon the principle of prevention in these three aspects, and especially on the two last. In the several States of the Union the doctrine of the English common law is incorporated in the statute laws, as to the classification of the crime and its effects, but the punishment is measured by special statutory enactment. In most of the States the power of pardoning a criminal is vested in the governor; in Pennsylvania, by constitutional provision, a Board of Pardons can make recommendations to the governor for pardons. This is the custom also in Massachusetts.

Crimp, an agent who for a commission supplies ships with seamen just before sailing, the term being applied especially to low characters who decoy sailors by treating them, advancing money to them, and giving them goods on credit, &c., till they have them in their power, frequently getting them shipped off in a drunken state after all their money is spent. They also keep an outlook for emigrants, and take them to low lodging-houses in which they themselves are interested.

Crimson, a rich deep red colour, a red that owes its characteristic tint to a certain admixture of blue.

Crin'an Canal, a canal in Argyleshire, Scotland, cutting off the peninsula of Cantyre from the mainland, and greatly shortening the route from Glasgow to Oban and other parts of the west coast; 9 miles long, 12 feet deep, admitting vessels of 200 tons.

Crinoi'dea (Gr. *krinon*, a lily), the encrinetes or sea-lilies, an order of Echinodermata, consisting of animals attached during the whole or a portion of their lives to the sea-bottom by means of a calcareous jointed stem, from the top of which radiate feather-like flexible appendages or arms, in the centre of which is the mouth. Though comparatively few in number now, they lived in immense numbers in former ages, many carboniferous limestones being almost entirely made up of their calcareous columns and joints.

Crin'oline (French, from Latin *crinis*, hair), properly a kind of fabric made chiefly of horse-hair, but afterwards generally applied to a kind of petticoat supported by steel hoops, and intended to distend or give a certain set to the skirt of a lady's dress. Hooped skirts (farthingales or fardingales), supported by whalebone, were worn in the time of Queen Elizabeth and James I., and the fashion was again introduced in the time of George II. The crinoline proper came in about 1856, and was worn by women of all ranks, sometimes proving by their portentous dimensions a source of much inconvenience and no little danger. The immense bell-shaped crinolines happily fell into disuse about 1866. Crinoline wire was for years a leading branch in the steel trade. A horse-hair and cotton fabric used as a material for making ladies' bonnets is also called crinoline.

Cri'num, a genus of handsome plants of the order Amaryllidaceæ, with strap-shaped leaves and a solid scape bearing an umbel of many rosy, fragrant flowers. There are numerous species found in Asia, Australia, South America, and certain parts of Africa, and interesting hybrids have been produced by our gardeners. The *Crinum asiaticum* has a bulb above ground, which is a powerful emetic, and is used by the natives to produce vomiting after poison has been taken.

Crio-sphinx (Gr. *krios*, a ram), a sphinx with the head of a ram, as distinguished

from the *andro-sphinx* or human-headed sphinx, and the *hieraco-sphinx* with the head of a hawk.



Crio-sphinx.

Cri'sis (from the Greek *krinein*, to decide), in medicine, the turning-point in a disease at which a decided change for the better or the worse takes place. In regular fevers the crisis takes place on regular days, which are called *critical days* (the 7th, 14th, and 21st); sometimes, however, a little sooner or later, according to the climate and the constitution of the patient. The word *crisis* is also figuratively used for a decisive point in any important affair or business, for instance, in politics and commerce. Commercial crises have been in an especial degree the subjects of study at the hands of economists, with the result of establishing a curious periodicity in their recurrence. The commercial cycle apparently completes itself in about ten years, the earlier portion of the period being attended with improving trade, a steady rise in prices, wages, and profits, and a considerable inflation of credit. Excitement, overtrading, and unwise speculation result in serious failures, and there follows a period of distrust and distress.

Crisp, CHARLES F., statesman, was born in Sheffield, England, of American parents, Jan. 29, 1845. After service in Confederate army he studied law; was Solicitor-general and Judge in Georgia; member of Congress, elected Speaker, 52-53d Congress.

Crittenden, JOHN J., statesman, was born in Woodford co., Ky., Sept. 10, 1787. He was a member of the State Legislature; of the U. S. Senate twice; Governor of Kentucky; U. S. Attorney-General. By his influence the State of Kentucky maintained its adherence to the Union. He died July 26, 1863.

Croa'tia, a country which forms, along with Slavonia and the 'Military Frontiers,' a province or administrative division in the south-west of the Austrian dominions in the Hungarian portion of the monarchy, partly bounded by the Adriatic; total area, 16,773 sq. miles. Its surface is irregular, the Alps extending into it, and culminating

at the height of 4400 feet. The Drave and the Save divide between them the whole drainage system. In the north, on low sunny slopes, the vine is successfully cultivated; the olive, mulberry, and fig thrive well on the coast. The south is generally unfertile, and in many parts almost sterile. The principal crops are barley and oats; but the whole country is more pastoral than arable. The inhabitants are Croats and Serbs, with a mixture of Germans, Hungarians, Jews, and Gypsies. About three-fourths of the population are Catholics, the rest belong chiefly to the Greek Church. The chief towns are Agram, Warasdin, and Karlstadt. Pop. 1891, 2,184,414. In 640 the Croats, a tribe from the Carpathians, settled in Croatia, and gave their name to the country. It long maintained a sort of independent existence, but in 1309 it was incorporated with Hungary.

Crochet (*krō'shā*), a species of knitting performed with a small hook, of ivory, steel, or wood, the material used being woollen, cotton, or silk thread. Various fancy articles, such as antimacassars, doyleys, &c., are made in crochet-work.

Crocid'olite, an ornamental stone, a sort of fibrous quartz, now brought in considerable quantities from Cape Colony and made into articles of jewelry.

Croc'in, a colouring matter obtained from the fruit of *Gardenia grandiflōra*, Chinese yellow pods, which is largely used in China for dyeing silk, wool, and other fabrics yellow.

Crocket, in Gothic architecture, an ornament, usually in imitation of curved and bent foliage, but sometimes of animals, placed on the angles of the sides of pinnacles, canopies, gables, &c. The name is also given to one of the terminal snags on a stag's horn.

Croc'odile, a genus, family, and order of saurian reptiles, comprising the largest living forms of reptiles. The characters of the order Crocodylia are as follows:—The skin is covered with square bony plates; the tail is long and compressed laterally. The four feet are short, and there are five toes on each of the two fore-feet, and four on each of the two hind-feet, the latter more or less webbed; the limbs are feeble. The jaws are long and their gape of enormous width. The nostrils are at the extremity of the snout, and capable of being closed to prevent ingress of water. The heart is four-chambered. The most ancient forms of the group

were the *Teleosaurus*, from the Lias and Oolite, and the *Streptospondylus*, from the Lias, Oolitic, and Wealden strata. The families now existing are the *Alligatoridæ*, *Crocodylida*, and *Gavialidæ*. The alligators are all New World forms. (See *Alligator*.) The gavial proper (*Gavialis gangeticus*) is confined to the East Indies. (See *Gavial*.) The *Crocodylida*, to which family



Crocodile (*Crocodylus niloticus* or *vulgaris*).

the crocodile belongs, have unequal teeth and no abdominal plates, and the cervical and dorsal plates are distinct for the most part. The crocodile of the Nile (*Crocodylus vulgaris*) is the best-known member of the order; another species (*C. palustris*) is met with in South Asia, Sunda, and the Moluccas. The crocodile is formidable from its great size and strength, but on shore its shortness of limb, great length of body, and difficulty of turning enable men and animals readily to escape pursuit. In the water it is active and formidable. It is exclusively carnivorous, and always prefers its food in a state of putrefaction. In Egypt it is no longer found except in the upper or more southern parts, where the heat is greatest and the population least numerous. Crocodiles are still common enough in the river Senegal, the Congo, Niger, &c. They grow sometimes to a length of 30 feet, and apparently live to a vast age.

Crocoi'site, a mineral, a native form of lead chromate, or red-lead ore. In it chromium was first discovered.

Crocus, a genus of plants of the order Iridaceæ or Iris, forming one of the most common ornaments of our gardens. Most of the species are natives of the south of Europe and the Levant; and three grow wild in Britain. They may be divided, according to their period of flowering, into *vernal* and *autumnal*. Among the vernal crocuses may be mentioned the white and purple *C. vernus*; *C. versicolor*, distinguished by the yellow tube of its flower

bearded with hairs, and its sweet scent; *C. biflorus*, the Scotch crocus, with beautiful pencilled sepals, and clear or bluish-white petals. Among the autumnal species are *C. nudiflorus* and *C. sativus*, whose long, reddish-orange, drooping stigmas, when dried, form *saffron*. See *Saffron*.

Cræsus, the last king of Lydia, son of Alyattes, whom he succeeded in 560 B.C., extending the empire from the northern and western coasts of Asia Minor to the Halys on the east and Mount Taurus on the south, including the Greek colonies of the mainland. His riches, obtained chiefly from mines and the gold-dust of the river Pactolus, were greater than those of any king before him, so that his wealth became proverbial. Having entered upon war with Cyrus he was taken prisoner in his capital, Sardis (B.C. 546). The date of his death is unknown, but he survived his captor, and is referred to in the reign of Cambyses.

Croft, WILLIAM, an English musical composer, born in 1677. He was organist in the chapel royal, and published *Musica Sacra*, or *Select Anthems*, &c. Died 1727.

Crofters, petty farmers renting a few acres of land, with sometimes the right of grazing their cattle in common on a piece of rough pasture. Crofters are numerous in the Highlands and in the Western Islands of Scotland, as well as in some other localities. From many districts they have been removed owing to their holdings being absorbed in sheep farms or deer forests, and they are now mainly congregated on the sea-shore, where they may partly maintain themselves by fishing. From the depression in agriculture and other causes the condition of the crofters has latterly become very precarious, and efforts have been made by philanthropists as well as by the legislature to relieve them. The Crofters' Act, passed in 1886, provides for security of tenure, the fixing of a reasonable rent, compensation for improvements, enlargement of buildings, &c. A crofter is defined by it as a yearly tenant, at a rent not above £30, of a holding situated in a 'crofting parish.' Commissioners appointed under the act have lately been going over the various crofting districts, and have been by their decisions granting great reductions of rent as well as cancelling large proportions of arrears.

Croker, JOHN WILSON, English writer and politician, born at Galway, in 1780. He was educated in Cork, and at Trinity College, Dublin, and called to the Irish bar

in 1802. In 1803 he published anonymously *Familiar Epistles on the Irish Stage*, and in 1805 an *Intercepted Letter from China*, both clever satires. In 1808 he entered parliament as member for Downpatrick. He was appointed in 1809 to the post of secretary to the admiralty, which he retained till the reign of William IV. The Reform Bill was strenuously opposed by him, and on the passing of that measure in 1832 he withdrew from public life. He was one of the founders of the *Quarterly Review*, and one of its ablest contributors, though his articles display frequent malevolence. His other writings include an edition of *Boswell's Life of Johnson*; *Ulm and Trafalgar*, and *Talavera*, two poems; *Stories from the History of England*, from which Sir Walter Scott derived his idea of *Tales of a Grandfather*; and editions of the *Suffolk Papers*, *Lady Hervey's Letters*, *Lord Hervey's Memoirs*, and *Walpole's Letters*. He died in 1857.

Croker, THOMAS CROFTON, collector of folk-lore, born at Cork in 1798. While in a merchant's office in Cork he commenced the collection of the songs and legends current among the peasantry of the south of Ireland. In 1819 an appointment in the admiralty was obtained for him, and he retired with a pension in 1850. His best-known work is his *Fairy Legends and Traditions of the South of Ireland* (1825). He died in 1854.

Croly, REV. GEORGE, LL.D., author and preacher, born at Dublin in 1780; studied at Trinity College, Dublin; was appointed to a small curacy in Ireland, but resigned it and became a prominent figure in London journalism and letters. His separate literary works comprise: *Paris* in 1815, a poem; *the Angel of the World*, tale; *Catiline*, a tragedy; *Pride shall have a Fall*, comedy, 1824; *Salathiel*, a romance; &c. He is also the author of a *Personal History of George IV.*; *the Political Life of Burke*; an edition of *Pope* and of *Jeremy Taylor*; a *Treatise on the Apocalypse*; *Divine Providence, or the Three Cycles of Revelation*; and numerous sermons. In 1835 he was made rector of St. Stephen's, Wallbrook. As a preacher he was deservedly popular. He died in 1860.

Crom'arty, a seaport and parliamentary burgh of Scotland, at the extremity of the peninsula which separates the Moray from the Cromarty Firth, 16 miles N.E. of Inverness. Fishing is the chief industry. Cromarty is one of the Wick burghs. It was

the birthplace of Hugh Miller. Pop. 1352. —The county of Cromarty consists of a large number of detached portions scattered over the county of Ross, with which they are practically merged. The total area is about 220,800 acres. See *Ross and Cromarty*.

Cromarty Firth, an inlet of the sea running into the united county of Ross and Cromarty in a south-westerly direction; length, about 18 miles; average breadth, 2 to 5 miles. Its entrance, between two wooded headlands called the Sutors of Cromarty, is about a mile wide. The firth affords excellent shelter for shipping. On its shores are the towns of Cromarty, Invergordon, and Dingwall.

Crom'dale, a village of Scotland on the east bank of the Spey, Inverness-shire, the scene of the fight of May 1st, 1690, in which a small body of the adherents of James II. was defeated by those of William III., celebrated in the ballad *The Haughs of Cromdale*.

Crome, JOHN, an English artist, son of a Norwich weaver; born in 1769. During greater part of his life he was a teacher of drawing. In 1805 he founded the Norwich Society of Artists, of which he became president as well as chief contributor to its annual exhibitions. He excelled in depicting the scenery of his native county, and especially in his handling of trees; and his high place among British landscape-painters is now universally acknowledged. He died in 1821. He is sometimes called 'Old Crome,' to distinguish him from his son, Bernay Crome, also an artist.

Cromer, a small seaport and bathing-place of England, county Norfolk, 21 miles N. of Norwich. The old town is now submerged, the sea constantly making fresh encroachments. Pop. (parish), 1597.

Cromlech (*krom'lek*), an ancient monument consisting of two or more columns of



Cromlech at Lanyon, Cornwall.

unhewn stone supporting a large tabular block so as to form a rectangular chamber, beneath the floor of which is sometimes found a cist inclosing a skeleton and relics.

CROMPTON — CROMWELL.

Sometimes the cromlech was encircled by a ring of standing-stones, as in the case of the Standing-stones of Stennis, in Orkney; and sometimes it was itself buried beneath a large mound of earth. See *Dolmen*.

Crompton, SAMUEL, inventor of the mule-jenny; born near Bolton, England, 1753. He early displayed a turn for mechanics, and when only twenty-one years of age invented his machine for spinning cotton, which was called a *mule*, from its combining the principles of Hargreave's spinning-jenny and Arkwright's roller-frame, both invented a few years previously. The mule shared in the odium excited among the Lancashire hand-weavers against these machines, and for a time Crompton was obliged to conceal his invention. He afterwards brought it again into work; but was unable to prevent others from profiting by it at his expense. Various improvements were introduced from time to time on the mule, but the original principle, as devised by Crompton, remained the same. The sum of £5000, voted to him by parliament in 1812, was almost all the remuneration which he received for an invention which contributed so essentially to the development of British manufactures. He died in 1827.

Crom'well, OLIVER, Lord-protector of the Commonwealth of England, Scotland, and Ireland, was born at Huntingdon April 25, 1599. His father, Robert Cromwell, who represented the borough of Huntingdon in the parliament of 1593, was a younger son of Sir Henry Cromwell, who was knighted by Queen Elizabeth; and Sir Henry again was a son of Sir Richard Williams, a nephew of Thomas Cromwell, Earl of Essex, whose name he took. Oliver's mother was a daughter of William Steward, of Ely, and could trace her descent back to Alexander, lord-steward of Scotland, the founder of the house of Stuart. The first really authentic fact in his biography is his leaving school at Huntingdon and entering Sidney-Sussex College, Cambridge, April 23, 1616. On the death of his father in 1617 he returned home, and in 1620 married Elizabeth, daughter of Sir James Burchier. In 1628 he was member of parliament for the borough of Huntingdon, to which he returned on the dissolution in 1629. In 1631 he went with his family to a farm which he had taken at St. Ives; and in 1636 to Ely, where he had inherited a property worth nearly £500 a year. During the Short and Long Parliaments he

represented Cambridge, his influence gradually increasing. In the summer of 1642 he was actively engaged in raising and drilling volunteers for the parliamentary party, in view of the impending struggle with the king. He served as captain and colonel



Oliver Cromwell.

in the earlier part of the war, doing good service with his troop of horse at Edgehill; and it was his energy and ability which made the Eastern Association the most efficient of those formed for mutual defence. At the battle of Winceby (1643) he led the van, narrowly escaping death, and in the following year he led the victorious left at Marston Moor, deciding the result of the battle. A few months later he was present at the second battle of Newbury, and his action being fettered by the timidity of Manchester, he impeached the conduct of the earl. As the result of this disagreement Sir Thomas Fairfax was made lord general, while Cromwell, notwithstanding the Self-denying Ordinance, was placed under him, with the command of the cavalry and the rank of lieutenant-general. As the result of the discipline introduced by Cromwell the decisive victory of Naseby was gained in 1645, and Leicester, Taunton, Bridgewater, Bristol, Devizes, Winchester, and Dartmouth fell into the hands of the parliament. On the occasion of the surrender of Charles by the Scottish army in 1646 Cromwell was one of the commissioners, and in the distribution of rewards for services received £2500 a year from the estates of the Marquis of Worcester. Though at first supporting parliament in its wish to disband the

CROMWELL.

army, which refused to lay down its arms till the freedom of the nation was established, he afterwards saw reason to decide in favour of the latter course. Hastily suppressing the Welsh rising, he marched against the Scottish royalists, whom he defeated with a much inferior force at Preston (Aug. 17, 1648). Then followed the tragedy of the king's execution, Cromwell's name standing third in order in the death-warrant. Affairs in Ireland demanding his presence, he was appointed lord-lieutenant and commander-in-chief; and by making a terrible example of Drogheda (September, 1649), crushed the royalist party in that country within six months. Resigning the command to Ireton, he undertook, at the request of the parliament, a similar expedition against Scotland, where Charles II. had been proclaimed king. With an army greatly reduced by sickness he saved himself from almost inevitable disaster by the splendid victory at Dunbar (Sept. 3, 1650), and a year later put an end to the struggle by his total defeat of the royalists at Worcester (Sept. 3, 1651). For these services he was rewarded with an estate of £4000 a year, besides other honours.

He already exerted a weighty influence in the supreme direction of affairs, being instrumental in restoring the continental relations of England, which had been almost entirely dissolved, and regulating them so as to promote the interests of commerce. The Navigation Act, from which may be dated the rise of the naval power of England, was framed upon his suggestion, and passed in 1651. The Rump Parliament, as the remnant of the Long Parliament was called, had become worse than useless, and on April 20, 1653, Cromwell, with 300 soldiers, dispersed that body. He then summoned a council of state, consisting mainly of his principal officers, which finally chose a parliament of persons selected from the three kingdoms, nicknamed *Barebone's Parliament*, or the *Little Parliament*. Fifteen months after a new annual parliament was chosen; but Cromwell soon prevailed on this body, who were totally incapable of governing, to place the charge of the commonwealth in his hands. The chief power now devolving again upon the council of officers (Dec. 12, 1653), they declared Oliver Cromwell sole governor of the commonwealth, under the name of *Lord-protector*, with an assistant council of twenty-one men. The new protector behaved with dignity and firmness. Despite the innumerable difficulties which

beset him from adverse parliaments, insurgent royalists, and mutinous republicans, the early months of his rule established favourable treaties with Holland, Sweden, Portugal, Denmark, and France. In Sept. 1656 he called a new parliament, which undertook the revisal of the constitution and offered Cromwell the title of king. On his refusal he was again installed as Lord-protector, but with his powers now legally defined. Early in the following year, however, he peremptorily dissolved the house, which had rejected the authority of the second chamber. Abroad his influence still increased, reaching its full height after the victory of Dunkirk in June, 1658. But his masterly administration was not effected without severe strain, and upon the death of his favourite daughter, Elizabeth Claypole, in the beginning of August, 1658, his health began to fail him. Towards the end of the month he was confined to his room from a tertian fever, and on Sept. 3, 1658, died at Whitehall, in the sixtieth year of his age. He was buried in King Henry VII.'s Chapel, in Westminster Abbey, but after the Restoration his body was taken up and hanged at Tyburn, the head being fixed on a pole at Westminster Abbey, and the rest of the remains buried under the gallows.—Great as a general, Cromwell was still greater as a civil ruler. He lived in a simple and retired way, like a private man, and was abstemious, temperate, indefatigably industrious, and exact in his official duties. He possessed extraordinary penetration and knowledge of human nature; and devised the boldest plans with a quickness equalled only by the decision with which he executed them. No obstacle deterred him; and he was never at a loss for expedients. Cool and reserved, he patiently waited for the favourable moment, and never failed to make use of it. In his religious views he was a tolerant Calvinist. He was about 5 ft. 10 in. in height, his body 'well compact and strong;' and his head and face, though wanting in refinement, were impressive in their unmistakable strength.

He had appointed his eldest son, Richard, his successor; but the republican and religious fanaticism of the army and officers, with Fleetwood at their head, compelled Richard to dissolve parliament; and a few days after he voluntarily abdicated the protectorship, April 22, 1659. His brother Henry, who from 1654 had governed Ireland in tranquillity, followed the example of Richard, and died in privacy in England.

At the Restoration Richard went to the Continent until 1680, when he assumed the name of *Clark*, and passed the remainder of his days in tranquil seclusion at Cheshunt, Hertfordshire. He died in 1712, at the age of eighty-six.—The last of the family was OLIVER CROMWELL, great-grandson of Henry Cromwell, son of the protector. He was a London solicitor, and clerk to St. Thomas' Hospital. He succeeded to the estate of Theobalds, which descended to him through the children of Richard Cromwell, and died at Cheshunt Park in 1821, aged seventy-nine. He wrote the *Memoirs of the Protector and his Sons*, illustrated by *Family Papers*, 1820.

Cromwell, THOMAS, Earl of Essex, son of a blacksmith at Putney, in Surrey; born about the year 1490. In his youth he was employed as clerk to the English factory at Antwerp; in 1510 went to Rome; and on his return to England became confidential servant of Cardinal Wolsey, about 1525. On his master's disgrace in 1529 Cromwell defended him with great spirit in the House of Commons, of which he was then a member; and effectually opposed the articles of treason brought against Wolsey. After the cardinal's death he was taken into the king's service, was knighted and made privy-councillor, and in 1534 became principal secretary of state and master of the rolls. In 1535 he was appointed visitor-general of all the monasteries in England, in order to suppress them, his services being rewarded by the post of lord-keeper of the privy seal, and the title of Baron Cromwell of Okeham. On the abolition of the pope's supremacy he was created king's vicar-general, and used all his influence to promote the Reformation. He was made chief-justice itinerant of the forests beyond Trent, knight of the Garter, and finally, in 1539, lord high chamberlain, and the following year Earl of Essex. He at length fell into disgrace with the king for the part he took in promoting his marriage with Anne of Cleves; and others of his political schemes failing, he was arrested on a charge of treason, and beheaded on Tower Hill, July 28, 1540.

Cronstadt (kron'stāt; Hungarian, *Brassó*), a town of Austria, in Transylvania, after Hermannstadt the principal seat of the industry and trade of the province, lying in a mountainous but well-wooded and romantic district near its south-east corner. Pop. 1891, 30,724.

Cronstadt, a maritime fortress of Russia,

about 20 miles w. St. Petersburg, in the narrowest part of the Gulf of Finland, opposite to the mouth of the Neva, on a long, narrow, rocky island, forming, both by its position and the strength of its fortifications, the bulwark of the capital, and being also the most important naval station of the empire. It was founded by Peter the Great in 1710, and has spacious regular streets with many handsome houses and churches, very large marine establishments, a naval arsenal, a cannon-foundry, building-yards, docks, &c. The harbour consists of three separate basins—a merchant haven, capable of containing 1000 ships; a central haven for the repair of ships of war; and the war haven, all of which are defended by strong fortifications. Cronstadt used to be the commercial port of St. Petersburg, but since the construction of a canal giving large vessels direct access to the capital it has lost this position. Pop. 48,276.

Cro'nus, in ancient Greek mythology, a son of Uranus and Ge (Heaven and Earth), and youngest of the Titans. He received the government of the world after Uranus was deprived of it, and was in turn deposed by Zeus. Cronus was considered by the Romans as identical with their Saturnus. See *Saturn*.

Croquet (krō'kā), an open-air game played with balls, mallets, hoops, and pegs on a level area, which should be at least 30 yards long by 20 wide. The iron hoops (shaped like the letter U) are fixed with their two ends in the ground, arranged in a somewhat zigzag manner over the ground; they are usually ten in number. The posts or pegs (two in number) are placed at the near and far end of the field respectively, marking the starting and turning points. The game may be played by any number of persons up to eight, either individually, or arranged in couples or in sides. The object of the players is to drive with the mallets the balls belonging to their own side through the hoops and against the posts in a certain order, and to prevent the balls of their opponents from completing the journey before their own by playing them against those of the enemy, and driving them as far as possible from the hoop or post to be played for; the player or players whose balls first complete the course claiming the victory.

Cro'sier, the staff borne by some of the higher dignitaries in the Roman Catholic and other churches, and probably the oldest of the insignia of the episcopal dignity.

CROSS — CROSS-BAR SHOT.

The original form of the staff resembled a shepherd's crook, but from the middle of the 14th century the archbishops began to carry, sometimes in addition to the pastoral crook, sometimes instead of it, a crosier terminating in a cross or double cross. The crosier is carried by bishops and archbishops themselves only in procession and when pronouncing benediction; on all other occasions it is carried before them by a priest. At Rome the right of bearing the crosier is peculiar to the pope himself, his crosier being in the form of a triple cross. The crosier or *dikanion* used in the Greek Church originally consisted of a simple staff ending in a large knob. At a later period it terminated in a ball (representing the world) with a cross above and two serpents twined round the upper part of the staff. The staff used in the Armenian Church is headed with a serpent in the form of a crook.

Cross, one straight body laid at any angle across another, or a symbol of similar shape. Among the ancients a piece of wood fastened across a tree or upright post formed a cross, on which were executed criminals of the worst class. It had, therefore, a place analogous to that of the modern gallows as an instrument of infamous punishment until it acquired honour from the crucifixion of Christ. The custom of making the sign of the cross in memory of Christ may be traced to the 3d century: Constantine had crosses erected in public places, palaces, and churches, and adopted it, according to a legend, as the device for a banner (*labarum*) in consequence of a dream representing it as the symbol of victory. In his time also Christians painted it at the entrance of their houses as a sign of their faith, and subsequently the churches were for the most part built in the form of a cross. It did not, however, become an object of adoration until after the alleged discovery of the true cross by the Empress Helena (A.D. 326). Its adoption as the Christian symbol may be held to connect itself with the fact that it was used emblematically long before the Christian era, in the same way that traces of belief in a trinity, in a war in heaven, in a paradise, a flood, a Babel, an immaculate conception, and remission by the shedding of blood, are to be found diffused amongst widely sundered peoples. The general meaning attached to the sign appears to have been that of life and regeneration. Since its adoption by Christianity it has undergone many modifications of shape, and has been employed in

a variety of ways for ornaments, badges, heraldic bearings, &c. After the introduction of the cross into the military ensigns of the Crusaders its use in heraldry became frequent, and its form was varied more than that of any other heraldic ordinary, some of

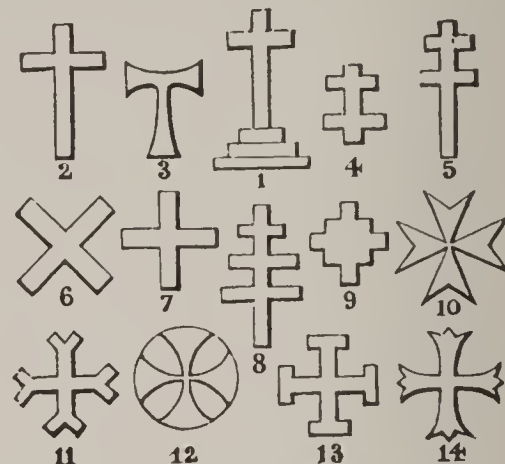

Forms of Crosses.

1, *Cross of Calvary*, a cross on three steps. 2, *Latin Cross*, a cross the transverse beam of which is placed at one-third of the distance from the top of the perpendicular portion, supposed to be the form of cross on which Christ suffered. 3, *Tau Cross* (so called from being formed like the Greek letter τ, *tau*), or cross of St. Anthony, one of the most ancient forms of the cross. 4, *Cross of Lorraine*. 5, *Patriarchal Cross*. 6, *St. Andrew's Cross*, the form of cross on which St. Andrew, the national saint of Scotland, is said to have suffered. 7, *Greek Cross*, or cross of St. George, the national saint of England, the red cross which appears on British flags. 8, *Papal Cross*. 9, *Cross nowy quadrat*, that is, having a square expansion in the centre. 10, *Maltese Cross*, formed of four arrow-heads meeting at the points; the badge of the knights of Malta. 11, *Cross fourchée* or *forked*. 12, *Cross pattée* or *formée*. 13, *Cross potent* or *Jerusalem Cross*. 14, *Cross fleury*, from the fleurs de lis at its ends.

the varieties being of great beauty. The name cross is also given to various architectural structures, of which a cross in stone was a prominent feature; thus we have market crosses, preaching crosses, monumental crosses, &c. The principal forms of the cross as a device or symbol are shown in the accompanying cut.

Cross, EXALTATION OF THE, a Catholic festival celebrated on the 14th of September in honour of the recovery of a portion of the true cross from the Persians by Heraclius (628 A.D.) and its erection on Mount Calvary.

Cross, INVENTION OF THE (the finding of the cross), a phrase chiefly used in connection with the Catholic festival in honour of the finding of the cross by the Empress Helena (A.D. 326), celebrated on the 3d of May.

Cross, VICTORIA. See *Victoria Cross*.

Cross-bar Shot, shots with iron bars crossing through them, sometimes standing out 6 or 8 inches at both sides, formerly used for destroying rigging, palisading, &c.

CROSS-BEARER — CROTCH.

Cross-bearer (*porte-croix*, *cruciger*), in the Roman Catholic Church, the chaplain of an archbishop or a primate, who bears a cross before him on solemn occasions.

Cross'bill (*Loxia*), a genus of birds of the finch family, deriving their name from a peculiarity of their bill, the mandibles of which are curved at the tips, so as to cross each other, sometimes on the one side and sometimes on the other. The form of the bill enables them to extract with ease the seeds of the pine, their usual food, from underneath the scales of the cones. They build and also breed at all seasons of the year, in December, as in March, April, or May. The common crossbill (*Loxia curvirostra*) is found in the northern countries of Europe, and is now more common in Britain than formerly. It is from 6 to 6½ inches in length. The male has a red plumage, the female is of a yellowish-green colour. The *Loxia pityopsittacus*, or parrot crossbill, sometimes visits Britain. Two species of crossbill inhabit Canada and the northern States, *Loxia Americana*, and *Curvirostra leucoptera*, or white-winged cross-bill.

Cross-bow, or ARBALIST, formerly a very common weapon for shooting, consisting of a bow fastened athwart a stock. The bow, which was often of steel, was usually bent by a lever windlass, or other mechanical contrivance, the missile usually consisting of a square-headed bolt or quarrel, but occasionally of short arrows, stones, and leaden bullets. Though largely used on the European continent the cross-bow was superseded at an early period in England by the more efficient long-bow, from which twelve arrows could be despatched per minute to three bolts of the cross-bow.

Cross-breeding, the breeding together of animals of different races or stocks. See *Breeding*.

Cross-days, the three days preceding the feast of the Ascension.

Crosse, ANDREW, English physician and scientist, born in 1784, died in 1855. He passed the greater part of his life experimenting in electricity. In 1816 he asserted that by electricity it was possible to communicate one's thoughts instantaneously to persons in the most distant parts of the earth, but he never appears to have attempted to demonstrate the fact by actual experiment. Amongst other things he applied electricity in the production of crystals, discovered a process of purifying salt water by electricity, and also made some curious dis-

coveries relative to the effects of positive and negative electricity on vegetation.

Cross-examination, the examination of a witness called by one party by the opposite party or his counsel.

Cross-fertilization, in botany, the fertilization of the ovule of one flower by the pollen of another, usually effected by the agency of insects, the action of the wind, water, &c. See *Botany*.

Crossopterygidæ (-rij'i-dē), a sub-order of ganoid fossil and recent fishes, so called from the fin-rays of the paired fins being arranged so as to form a fringe (Gr. *krossoi*) round a central lobe. The living *Polypterus* and *Ceratodus* belong to this group.

Cross-staff, an instrument used by surveyors consisting of a staff carrying a brass circle divided into four equal parts by two lines intersecting each other at right angles. At the extremity of each line perpendicular sights are fixed, the instrument being used in taking offsets.

Cross-stone, a name given to the minerals *harmotome*, a hydrated silicate of barium and aluminium, and *staurolite*, a silicate of iron and aluminium, in both of which the crystals cross each other. Harmotome, however, has by some mineralogists been called *staurolite*. The name cross-stone is sometimes also given to chiascolite, because of the occasional dark markings on the summits of the crystals.

Cross-trees, in ships, certain pieces of timber at the upper ends of the lower and top masts, athwart which they are laid, to sustain the frame of the tops in the one, and extend the top-gallant shrouds on the other.

Crotalaria, a genus of leguminous plants, all natives of warm climates, but some of them long cultivated in hothouses. *C. juncæa* is the sunn-hemp plant.

Crotal'idæ, a family of serpents including some of the most dangerous, above all the rattlesnakes.

Crotch, WILLIAM, musical composer, born at Norwich in 1775. As a child he showed astonishing precocity, and at the age of twenty-two was appointed professor of music at Oxford University, with the degree

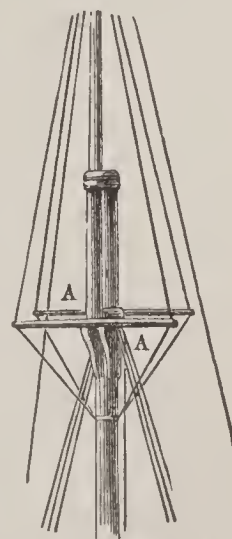

A A, Cross-trees.

of Doctor of Music. In 1822 he became principal of the Royal Academy of Music. He died in 1847. He left a large number of compositions, more especially for the organ, piano, and voice, and three technical treatises.

Crotchet. See *Music*.

Cro'ton, a genus of herbaceous plants, shrubs, and trees, order Euphorbiaceæ, comprehending a great number of species, many of which possess important medical properties. The more remarkable species are *C. Cascarilla*, a native of the West Indies and Florida, which yields the cascarilla bark, a valuable aromatic tonic; *C. laccifërum*, a native of the East Indies, said to furnish



Croton Tiglium.

the finest of all the sorts of lac; *C. Tiglium*, an inhabitant of the East Indies, from the seeds of which croton-oil is extracted (see *Croton-oil*); and *C. Draco*, a Mexican plant, which yields a red resinous substance used in making varnish. *C. Pseudo-china*, the copalche plant, yields the bark of that name, but *C. balsamifërum*, *C. aromaticum*, and *C. thurifërum* are merely aromatic.

Cro'ton, CROTO'NA (the modern COTRONE), in ancient geography, a Greek republic in Magna Græcia or South Italy, famous for its *athleta*, among whom the chief was Milo. It is still more celebrated as the city where Pythagoras taught between 540 and 530 B.C.

Croton-oil, a vegetable oil expressed from the seeds of the *Croton Tiglium*. It is so strongly purgative that one drop is a full dose, and half a drop will sometimes produce a powerful effect, and it should never be used except by the direction of an experienced physician. When applied externally it causes irritation and suppuration, and

thus it is used as a counter-irritant in neuralgia, &c.

Crottles, a popular name of various species of lichens collected for dyeing purposes, and distinguished as black, brown, white, &c., crottles. Under it are included *Parmelia physodes*, *P. caperata*, *P. saxatilis*, *Sticta pulmonaria*, and *Lecanora pallescens*.

Croup (kröp). Two diseases are commonly confounded under the term 'croup,' one a simple and, if promptly treated, a readily subdued disease, the other most fatal. The former is simple inflammation of the inner lining membrane of the larynx—the box of the windpipe—or of the windpipe itself, or of both. It is common in children, and as the air-passage of children is narrow, the swelling produced by the inflammation so diminishes the fair-way that difficult breathing, hoarseness of voice, and a cough like a muffled bark are quickly produced, while the breathing sounds loud and harsh. The other disease is diphtheria of the larynx or windpipe, or both, in which a false membrane is formed which lines the air-passages, and so narrows them. Croup frequently proves fatal by suffocation, induced either by spasm affecting the glottis, or by a quantity of matter blocking up the air-passages. The earliest symptoms should be noted, and the treatment in the absence of immediate medical advice should consist in the application of hot poultices to the upper part of the chest, while at the same time the child is made to inhale the steam from hot water. Hot drinks are beneficial, and the bowels should be freely opened.

Crousaz (krö-zä), JEAN PIERRE DE, Swiss mathematician and philosopher, born in 1663, died in 1748 or 1750. His chief works are: *Système des Réflexions, ou nouvel Essai de Logique*; *Traité du Beau*; *De l'Education des Enfants*; *Traité de l'Esprit Humain*; &c.; also an examination of Pope's *Essay on Man*.

Crow (*Corvus*), a genus of birds, type of the family Corvidæ. It includes, as British species, the carrion-crow, the hooded or Royston crow, the raven, the rook, and the jackdaw, the last three of which are described under their respective heads. The carrion-crow, or simply the crow (*C. corone*), is 18 or 19 inches in length, and about 36 between the tips of the wings. Its plumage is compact and glossy blue-black with some greenish reflections. Its favourite food is carrion of all kinds; but it also preys upon small quadrupeds, young birds, frogs, lizards, &c.,

and is a confirmed robber of the nests of game birds and poultry. It is not gregarious, being generally met with either solitary or in pairs. It builds a large isolated nest, with from four to six eggs, generally of a bluish-green with blotches of brown. The carrion-crow is easily tamed, and may be taught to articulate words. The American crow (*C. americanus*) is similar to the foregoing, but is smaller and less robust, and is somewhat gregarious. This crow is common in all parts of the United States, and is deemed a great nuisance by farmers from preying on their corn. The fish-crow (*C. ossifragus*), another American crow, resembling the preceding but smaller, is abundant in the coast districts of the Southern States. Its favourite food is fish, but it also eats all kinds of garbage, mollusca, &c. In winter its food is chiefly fruit, and it is then fat and considered good eating. The hooded, Royston, or gray-backed crow (*C. cornix*) is somewhat larger than the rook. Its head, wings, and tail are black, but less bright than in the rook; the rest of the body is a dull smoke-gray. Its food is similar to that of the carrion-crow, and it builds a similar nest. Indeed, the distinctness of the species *C. corone* and *C. cornix* has been called in question, as they interbreed freely together, and the young of the same nest present more or less resemblance to the one or the other parent. The hooded crow is less common in England than in Scotland and Ireland. All the crows are highly sagacious.

Crowberry, or **CRAKEBERRY** (*Empetrum nigrum*), a plant resembling the heaths, and bearing a jet-black berry, common in all the northern parts of Europe and Asia, including Scotland and England; also natives of N. America. The berries, which have a slight acid taste and are sometimes eaten, afford a purple dye. The red crowberry (*E. rubrum*), which has a red fruit, grows in the neighbourhood of the Straits of Magellan.

Crow-blackbird, the name of certain American birds of the genus *Quiscalus*, family Sturnidæ or starlings. The great crow-blackbird (*Q. major*), found in the Southern States, Mexico, and the West Indies, is 16 inches long, and of a glossy black plumage. The female is of a light-brown above and whitish beneath. The purple grackle, lesser or common crow-blackbird (*Q. versicolor*), is similar in colour to the preceding, but smaller. They reach the middle states

of America from the south in flocks in the latter part of March, and build in April in the tall pines or cedars. On their first arrival they feed upon insects, but afterwards commit great ravages upon the young corn. In November they fly southward again.

Crow'foot. See *Ranunculus*.

Crow'land, or **CROYLAND**, a town in England, county of Lincoln, 8½ miles north of Peterborough. Pop. 2929. Its chief points of interest are the curious ancient triangular bridge at the confluence of the Welland and the Nene, and the ruins of an abbey founded in 716 by Ethelbald. Ingulphus was abbot of Crowland from 1075 till 1109.

Crown, a circular ornament for the head. As now used the name is limited to the head-dress worn by royal personages as a badge of sovereignty, but it was formerly used to include the wreaths or garlands worn by the ancients upon special occasions. Thus, among the Greeks and Romans, crowns made of grass, flowers, twigs of laurel, oak, olive, parsley, &c., and latterly of gold, were made use of as honours in athletic contests, as rewards for military valour, and at feasts, funerals, &c. It is, however, with the eastern diadem rather than with the classic corona that the crown as a symbol of royalty is connected; indeed, it was only introduced as such a symbol by Alexander the Great, who followed the Persian usage. Antony wore a crown in Egypt, and the Roman emperors also wore crowns of various forms, from the plain golden fillet to the radiated or rayed crown. In modern states they were also of various forms until heralds devised a regular series to mark the grades of rank from the imperial crown to the baron's coronet. The English crown has been gradually built up from the plain circlet with four trefoil heads worn by William the Conqueror. This form was elaborated and jewelled, and finally arched in with jewelled bands surmounted by the cross and sceptre. As at present existing the crown of England is a gold circle, adorned with pearls and precious stones, having alternately four Maltese crosses and four fleurs-de-lis. From the top of the crosses rise imperial arches, closing under a mound and cross. The whole covers a crimson velvet cap with an ermine border. The crown of Charlemagne, which is preserved in the imperial treasury of Vienna, is composed of eight plates of gold, four large and four small, connected by hinges. The

large plates are studded with precious stones, the front one being surmounted with a cross; the smaller ones, placed alternately with these, are ornamented with enamels representing Solomon, David, Hezekiah, and



1, Crown of England. 2, Russian Crown. 3, French Crown. 4, Austrian Crown. 5, Imperial Crown (Charlemagne's).

Isaiah, and Christ seated between two flaming seraphim. The Austrian crown is a sort of cleft tiara, having in the middle a semi-circle of gold supporting a mound and cross; the tiara rests on a circle with pendants like those of a mitre. The royal crown of France is a circle ornamented with eight fleurs-de-lis, from which rise as many quarter-circles closing under a double fleur-de-lis. The triple crown of the popes is more commonly called the tiara.

Crown, a silver coin value five shillings, current in Britain, though now scarce, none having been coined (except a few in 1887) since 1851. In 1847 and 1848 some pattern crowns were struck with a gold centre, but the experiment was carried no further.

Crown Debts, debts due to the British crown, whose claim ranks before that of all other creditors, and may be enforced by a summary process called an extent.

Crown-glass, the hardest and most colourless kind of window-glass, made almost entirely of sand and alkali and a little lime, and used in connection with flint-glass for optical instruments in order to destroy the disagreeable effect of the aberration of colours.

Crown Imperial. See *Fritillary*.

Crown Lands, the lands belonging to the British crown. These are now surrendered to the country at the beginning of every sovereign's reign in return for an allowance (the Civil List) fixed at a certain amount

for the reign by parliament. They are placed under commissioners, and the revenue derived from them becomes part of the consolidated fund. For the year ending March, 1888, the net revenue of the crown lands amounted to £390,000. See *Civil List*.

Crown Solicitor, in England, the solicitor to the treasury, who instructs counsel in all state prosecutions. In Ireland, an officer attached to each circuit, paid by a salary, whose duty it is to take charge of every case for the crown in criminal cases.

Crown-wheel, a wheel with cogs or teeth set at right angles to its plane, the wheel in certain watches that drives the balance.

Croydon, a municipal and parl. borough, England, in county Surrey, 10 miles s. of London, of which it is practically a suburb, near the sources of the Wandle, and near the Banstead Downs. The town, which is a favourite residence of merchants and business men, retired tradesmen, &c., is surrounded by fine villas, mansions, and pleasure-grounds. It is a place of ancient origin, but from its recent rapid increase is almost entirely new. Of special interest are the remains of the ancient palace, long a residence of the Archbishops of Canterbury. Croydon was made a municipal bor. in 1883, a parl. bor. with one member in 1885. Pop. 1891, 102,697.

Crozet Islands, a group of four uninhabited islands in the South Indian Ocean, between Kerguelen and Prince Edward Islands. They are all of volcanic origin, and the most easterly of them, East Island, has peaks exceeding 4000 feet. The largest, Possession Island, is about 20 miles long by 10 broad.

Crozier. See *Crosier*.

Cru'cian Carp, a thick, broad fish, of a deep yellow colour, the *Cyprinus carassius*, differing from the common carp in having no barbules at its mouth, inhabiting lakes, ponds, and sluggish rivers in the north of Europe and Asia.

Cru'cible, a vessel employed to hold substances which are to be submitted to a high temperature without collecting the volatile products of the action. It is usually of a conical, circular, or triangular shape, closed at the bottom and open at the top, and is made of various materials, such as fire-clay, platinum, a mixture of fire-clay and plumbago, porcelain, &c.

Crucif'eræ, a very extensive nat. order of dicotyledonous plants, consisting of herbs which all have flowers with six stamens,

two of which are short, and four sepals and petals, the spreading limbs of which form a Maltese cross, whence their name. The fruit is a pod with a membranous placenta dividing it into two cells. The mustard, water-cress, turnip, cabbage, scurvy-grass, radish, horse-radish, &c., belong to this family. They have nearly all a volatile acridity dispersed through every part, from which they have their peculiar odour and sharp taste, and their stimulant and antiscorbutic qualities. None are really poisonous. Some are found in our gardens because of their beauty or fragrance, as the wall-flower, stock, candytuft, &c.

Cru'cifix, a cross bearing the figure of Christ. As a rule the figures on the most ancient crucifixes were not carved, but were engraved on gold, silver, or iron crosses. At a later period they were painted on wood, and it is only in the 9th century, in the pontificate of Leo III., that the figure of Christ appears carved upon the cross in bass-relief. Originally the body was represented clothed in a tunic reaching to the feet; afterwards the clothing was removed with the exception of a cloth round the loins. Until the 11th century Christ is represented alive; since that period he has been represented as dead. In the earlier crucifixes, also, the number of nails by which Christ is fixed to the cross is four, one through each hand and each foot, while in the more modern ones one foot is laid above the other and a single nail driven through both. Many crucifixes bear also the superscription in an abbreviated form, and accessory symbols and figures.

Crucifixion, a mode of inflicting capital punishment, by affixing criminals to a wooden cross, formerly widely practised, but now chiefly confined to the Mohammedans. Different kinds of crosses were employed, especially that consisting of two beams at right angles, and the St. Andrew's cross.

Cruden, ALEXANDER, compiler of the Concordance to the Scriptures, was born at Aberdeen in 1701. He took the degree of M.A. at Marischal College, and in 1722 proceeded to London, where he was employed as tutor. He afterwards opened a bookseller's shop under the Royal Exchange, and in 1735 was appointed bookseller to Queen Caroline. His great work appeared in 1737, under the title of *A Complete Concordance of the Holy Scriptures of the Old and New Testament*. In a pecuniary point of view it was not at first successful, and

the embarrassments to which it reduced him unsettled his reason and led to his confinement at Bethnal Green. He was again temporarily confined in 1753. He died in Islington in 1770. Three editions of the Concordance appeared in his lifetime, and he was also the author of *A Scripture Dictionary, or Guide to the Holy Scriptures*; and *The History and Excellency of the Scriptures*.

Cruelty to Animals. See *Animals, Cruelty to*.

Cruikshank, GEORGE, the greatest of English pictorial satirists after Hogarth, born in London 1792, of Scottish extraction. His father, Isaac Cruikshank, was an engraver of theatrical portraits, prints for cheap books, and caricatures in the manner of Rowlandson and Gillray. From early childhood George Cruikshank was trained to assist in preparing his father's plates. The earliest of his drawings known is dated 1799, when he was only seven years of age, and when fifteen he was comparatively distinguished. His first occupation was designing illustrations for children's books and popular songs. He began early also as a political satirist, contributing plates regularly in 1811 to the *Scourge*, in 1814 illustrating Dr. Syntax's *Life of Napoleon*, and doing much work of the kind for Hone, the publisher. His best productions of this period are his drawings of the *Cato Street Conspiracy* and of the trial of Queen Caroline, the *Political Showman*, and the *Political House that Jack Built*. In 1821 and the succeeding years appeared his illustrations of such popular books as Pierce Egan's *Tom and Jerry*; Maxwell's *History of the Irish Rebellion*, Grimm's *Fairy Tales*, Peter Schlemihl, Baron Munchhausen, Defoe's *History of the Plague*, Scott's *Demonology and Witchcraft*, the *Ingoldsby Legends*, &c., the artist showing especial excellence in ghostly and fairy subjects. In 1837 he commenced in Bentley's *Miscellany* his famous series of etchings on steel illustrative of Dickens's *Oliver Twist*, followed two years later by those for Ainsworth's *Jack Sheppard*, and then by those for Windsor Castle and the Tower of London. Having connected himself with the temperance movement he produced the *Bottle*, a powerful and popular series of designs, but marking clearly the limits of his art. His temperance connection and his absurd claims to having suggested the idea of Dickens's *Oliver Twist*, undermined his artistic reputation.

Poorly paid for work by which others profited, he was latterly obliged to part with the vast collection of his works, and in 1866 £50 a year was settled on him from the Royal Academy's Turner Annuities. He latterly turned his attention to oil-painting, his most noteworthy pictures being *Tam o' Shanter*, *Disturbing a Congregation*, and *The Worship of Bacchus*. He died in 1878.

Cruise (*kröv*), a trap for fish, especially salmon, consisting of a sort of hedge of stakes on a tidal river or the sea-beach. When the tide flows the fish swim over the wattles, but are left by the ebb.

Crusades, the wars carried on by the Christian nations of the West, from the end of the 11th till the latter half of the 13th century, for the conquest of Palestine. They were called *Crusades*, because the warriors wore the sign of the cross. The antagonism between the Christian and Mohammedan nations had been intensified by the possession of the Holy Land by the Turks and by their treatment of pilgrims to Jerusalem; and the first strenuous appeal was assured of response alike from the pious, the adventurous, and the greedy. The immediate cause of the *first Crusade* was the preaching of Peter of Amiens, or Peter the Hermit, who in 1093 had joined other pilgrims on a journey to Jerusalem. On his return he gave Pope Urban II. a description of the unhappy situation of Christians in the East, and presented a petition for assistance from the Patriarch of Jerusalem. The statements of the pope at the Councils of Piacenza and Clermont in 1095 produced a profound sensation throughout Europe, and in 1096 several armies set out in different divisions, most of which, being ignorant of military discipline and unprovided with necessaries, were destroyed before reaching Constantinople, which had been chosen for their place of meeting. A well-conducted regular army, however, of 80,000 men was headed by Godfrey of Bouillon; Hugh of Vermandois, brother to Philip, king of France; Baldwin, brother of Godfrey; Robert II. of Flanders; Robert II. of Normandy, brother of William II., king of England; Raymond of Toulouse; and other heroes. They traversed Germany, Hungary, and the Byzantine Empire, passed over into Asia Minor, conquered Nicæa in June 1097, and shortly after, on the 4th of July, fought the first pitched battle at Dorylæum, being completely victorious after a severe contest. They then marched through Asia Minor

upon Antioch, which, with the exception of the citadel, fell into their hands by treachery in June 1098. Surrounded in turn by a Turkish army, they were soon reduced to pitiable straits, but succeeded in routing their besiegers on June 28. After remaining nearly a year in the neighbourhood of Antioch they commenced, in May 1099, their march against Jerusalem, the siege of which they commenced in June. Their numbers were now reduced to little more than 20,000 men; but after a fierce struggle the town was taken by storm on July 15, and Godfrey of Bouillon was chosen king of Jerusalem, or, as he preferred to term himself, Protector of the Holy Sepulchre. At his death in 1100 he was succeeded by his brother Baldwin, who had in the earlier part of the Crusade established himself in Edessa, and made himself ruler of an extensive territory stretching over the Armenian mountains and the plain of Mesopotamia.

The *second* great and regularly-conducted Crusade was occasioned by the loss of Edessa, which the Saracens conquered in Dec. 1144. Fearing still graver losses, Pope Eugenius III., seconded by Bernard of Clairvaux, exhorted the German emperor Conrad III., and the King of France, Louis VII., to defend the cross. Both these monarchs obeyed, and in 1147 led large forces to the East, but returned without accomplishing anything in 1149.

The *third* Crusade was undertaken after the capture of Jerusalem by Saladin in 1187, the monarchs Frederick I. (Barbarossa) of Germany, Philip Augustus of France, and Richard I. (Cœur de Lion) of England, leading their armies in person. Frederick, marching by way of the Danube and crossing from Gallipoli, defeated the Turks at Philomelium (now Finiminum), and penetrated to Seleucia, but was drowned in the Selef. His son Frederick led the small remains to Acre and took part in the siege, but after his death in 1191 the German army dwindled away. The other monarchs—Richard and Philip Augustus—had in the meantime met at Vezelai in June, 1190, and agreed to unite their forces at Messina in Sicily, where they spent six months at the end of 1190 and beginning of 1191. Philip joined the other Crusaders before Acre on April 13, 1191; but Richard, whose fleet was separated by a storm, went to Cyprus, and, dispossessing Isaac Comnenus, made himself king. It was not till the 8th

of June that he reached Acre, which surrendered a month later. Jealousies, however, arose between the monarchs, and within a few weeks after the fall of Acre the French king returned to Europe. Richard, now sole leader of the expedition, defeated Saladin and occupied Jaffa or Joppa; but having twice vainly set out with the design of besieging Jerusalem, he concluded (Sept. 2, 1192) a truce of three years and three months with Saladin, who agreed that pilgrims should be free to visit the Holy Sepulchre, and that the whole sea-coast from Tyre to Jaffa (including the important fortress of Acre) should belong to the Crusaders.

The *fourth* Crusade was set on foot by Pope Innocent III., who commissioned Fulk of Neuilly to preach it in 1198. Among its chief promoters was Godfrey of Villehardouin, seneschal of Champagne; Baldwin, count of Flanders and Hainaut; Dandolo, the aged doge of Venice; and the Marquis of Montferrat, who was chosen leader. The Crusaders assembled at Venice in the spring of 1202, but were diverted from their original purpose first by the capture of the Dalmatian town of Zàra, and then by the expedition which ended in the sack of Constantinople and the establishment of a Latin empire there (1204).

The *fifth* Crusade, undertaken by Andreas of Hungary in 1217, and shared in by John of Brienne, to whom the title of King of Jerusalem was given, had little other result than the temporary occupation of the Nile delta.

The *sixth* Crusade, that of Frederick II., emperor of Germany, was undertaken at the instance of Popes Honorius III. and Gregory IX. On arriving he entered into negotiations with the Sultan of Egypt, and without any fighting recovered for himself, as heir of John of Brienne, the Kingdom of Judea, on the condition of tolerating in his kingdom the Mohammedan worship. He then concluded a useless truce of ten years, got himself crowned at Jerusalem, and returned in 1229.

The *seventh* and *eighth* Crusades were led by St. Louis of France (Louis IX.) in person. This prince was resolved to strike a blow at Mohammedanism in Egypt. He took Damietta in June 1249, and marched up the Nile, but was compelled to retreat, and finally to surrender with his whole army. He recovered his liberty by the surrender of Damietta, returned to Palestine, and in 1254,

on the death of his mother, to France. The second expedition of Louis was still more disastrous in its results than the first. He landed his army in 1270 on the northern coast of Africa; but he himself and a large number of his knights died before Tunis, and the majority of the French Crusaders returned home. A crusading army under Prince Edward of England (afterwards Edward I.), originally intended to co-operate with that of Louis, landed at Acre in 1271, but little was effected beyond a new truce for ten years (1272). For nineteen years longer the Christians in Palestine held with great difficulty the remnants of the Latin kingdom there. But Tyre and Berytus (Beirut) were successively snatched from them, and finally the capture of Acre by the Sultan of Egypt in 1291 put an end to the kingdom founded by the Crusaders.

Despite their want of success, however, the crusades were of considerable indirect value in that by these joint enterprises the European nations became more connected with each other, the class of citizens increased in influence, partly because the nobility suffered by extravagant contributions to the Crusades, and partly because a more intimate commercial intercourse greatly augmented the wealth of the cities, and a number of arts and sciences, till then unknown in Europe, were introduced.

Crusa'do. See *Cruzado*.

Crusca, ACCADEMIA DELLA. See *Academy*.

Crusta'cea, one of the primary branches into which is divided the great group of Articulate or Annulose animals. The body is divided into head, thorax, and abdomen, of which the two former are united into a single mass, cephalothorax, covered with a shield or carapace, and the abdomen usually presents the appearance of a tail. In some — the sand-hopper, wood-louse, &c. — the head is partially distinct from the thorax. The Crustacea breathe by branchiæ or gills, or by membranous vesicles, or by the general surface; and the body is composed of a series of rings more or less distinct. They possess the faculty of reproducing lost parts in an eminent degree. The integument is chitinous (see *Chitin*) and remains elastic in some, as the Isopods, throughout life. But in the majority it is calcified or transformed into a hard shell, prisms of carbonate of lime being deposited in the outer layer. It consists of a great number of distinct pieces connected together by portions of the epidermic envelope, just as among the higher

animals certain bones are connected together by cartilages. Several species, if not all, moult or cast these outer skeletons or shells in the progress of growth; this is the case with crabs, crayfish, &c. The general grouping of the Crustacea is sometimes based upon the successive metamorphoses which the higher Crustaceans undergo before reaching the adult form. Thus the first stage of the lobster embryo is that of a minute object with three pairs of limbs, known as the Nauplius-form; in the second, or Zoëa-stage, the cephalo-thorax is provided with anterior, posterior, and lateral spines; the final form being reached by a series of moultings. But for practical purposes the Crustacea may be considered as ranging themselves under four sub-classes:—the Cirripedia, the Entomostraca, the Podophthalmia, and the Edriophthalmia. Of these, the Cirripedia are represented by the barnacles; the Entomostraca by the cyclops, daphnia, &c.; the Podophthalmia by the shrimps, prawns, lobsters, &c.; the Edriophthalmia by the fish-lice, wood-lice, beach-fleas, &c. Besides the orders comprised under these classes there are, however, several groups, such as the Merostomata and the Trilobites, which lie between the Crustaceans and the Insects, and are as yet unattached to either.

Crutched Friars, an order of friars established at Bologna in 1169, and so named from their adopting the cross as their special symbol. It originally formed the head of their distinctive staff; afterwards they wore it in red cloth on the back and breast of their blue habit.

Cruz, SANTA. See *Santa Cruz*.

Cruza'do, a Portuguese coin. The old cruzado or cruzado-velho is worth 400 reis, or 1s. $9\frac{1}{2}d.$; the new cruzado, cruzado-novo or pinto, dating from 1722, is worth 480 reis, or 2s. $1\frac{3}{4}d.$

Crwth (*krwth*), a Welsh name for a kind of violiu with six strings, formerly much used in Wales. Four of the strings were played on by a bow, and two were struck or twitched by the thumb. Its general length was 22 inches, and its thickness $1\frac{1}{2}$ inch.

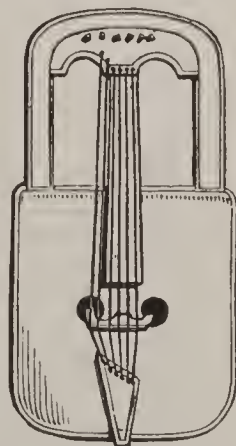

Crwth.—Carl Engel's Musical Instruments.

Cry'olite, or KRYOLITE, a mineral, a native fluoride of aluminium and sodium, found at

Evigtok, in Greenland, whence it is exported. It is of a pale grayish-white or yellowish-brown, occurs in masses of a foliated structure, and has a vitreous lustre. It has been employed as a source of aluminium, and in the manufacture of a hard porcellanous glass of great beauty. In addition to the Evigtok deposit cryolite has been discovered in the Ural.

Cryoph'orus (Gr. *kryos*, cold), an instrument for showing the diminution of temperature in water by its own evaporation. Wolleston's cryophorus consists of two glass globes united by a moderately-wide glass tube. Water is poured in and boiled to expel the air, and while boiling the apparatus is hermetically sealed. When it is to be used the water is made run into one of the globes, and the other is buried in a freezing-mixture. The aqueous vapour in the globe being thus condensed, a vacuum is produced, fresh vapour rises from the water in the other globe, which is again condensed, and this proceeds continuously till the water remaining in the globe has been, by the evaporation, cooled to the freezing-point.

Crypt, originally a subterranean cell or cave, especially one constructed for sepulture. From the usage of these by the early Christians crypt came to signify a church underground or the lower story of a cathedral or church. It is usually set apart for monumental purposes, but is sometimes used as a chapel. The crypt is a common feature of cathedrals, being always at the east end, under the chancel or apse. The largest in England is that of Canterbury Cathedral; that of Glasgow Cathedral, formerly used as a separate church, is 'one of the most perfect pieces of architecture' in Britain.

Cryptog'amous Plants, CRYPTOGAMIA, in botany, the division embracing the lower classes of plants having no evident flowers or in which the reproductive organs are obscure. They are propagated by spores. They are divided into cellular and vascular cryptogams, the former comprising the algæ, fungi, lichens, charas, liverworts, and mosses; the latter the ferns, horse-tails, moonworts, rhizocarps, and lycopods.

Cryptog'raphy, the art of writing in secret characters or cipher, or with sympathetic ink. The simplest method consists in choosing for every letter of the alphabet some sign, or another letter or group of letters. Thus the letter of Charles I. to the Earl of Glamorgan with respect to the Catholics of Ireland was composed in an

CRYSTAL — CRYSTAL PALACE.

alphabet of 24 strokes variously placed about a line. The names in the records of the Clan-na-Gael Society were, according to the Times newspaper, written in a cipher formed by taking in each case the letter previous to that intended; and the cipher devised by Lord Bacon consisted in an alphabet formed by different arrangements of the letters *a* and *b* in groups of five. All these methods, however, are easily deciphered by experts, as also is that employed by the Earl of Argyle in his plot against James II., in which the words of the letter were set down at concerted distances, the intervals being filled up with misleading words. Even the more complex, however, present, **as a rule, but little difficulty to an expert.**

Crypton, a new element discovered June, 1898, by Prof. Ramsey, with Lord Rayleigh, joint discoverers of argon. Was eliminated from the atmosphere in which it exists as 1 to 20,000. Spectrum: chief lines, green and yellow, latter being nearly coincident with the helium yellow line, D 3.

Crystal, in chemistry and mineralogy, any body which, by the mutual attraction of its particles, has assumed the form of some one of the regular geometric solids, being bounded by a certain number of plane surfaces. The chemist procures crystals either by fusing the bodies by heat and then allowing them gradually to cool, or by dissolving them in a fluid and then abstracting the fluid by slow evaporation. The method of describing and classifying crystals now universally adopted is based upon certain imaginary lines drawn through the crystal, and called its *axes*. The classes are as follow:—1st, The *monometric, regular, or cubic system* (*a*), in which the axes are equal and at right angles to one another; 2d, The *square prismatic or dimetric system* (*b*), in which the axes are at right angles to each other, and while two are equal, the third is longer or shorter; 3d, The *right prismatic, rhombic, or trimetric system* (*d*), in which the axes are at right angles to each other, but all are of different lengths; 4th, The *hexagonal or rhombohedral system* (*c*), which has four axes, three in one plane inclined to each other at 60°, the fourth perpendicular to this plane; 5th, The *monoclinic or oblique system* (*e*), in which two axes are at right angles and the third is inclined to their plane; 6th, The *dialinic or doubly oblique system* (*f*), in which two axes are at right angles, the third oblique to both; 7th, The *triclinic system* (*g*), in which the

three axes are inclined to each other at any angle other than a right angle. A crystal consists of three parts. 1st, Plane surfaces, called faces, which are said to be similar when they are equal to one another and similarly situated; dissimilar, when they are

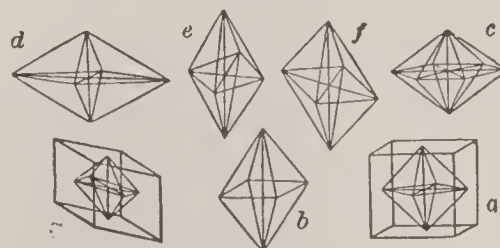

Crystals.

unequal or have a different position. 2d, Edges, formed by the meeting of two faces. They are said to be similar when formed by similar faces; dissimilar, by dissimilar faces. Equal edges are formed when the faces are inclined at the same angle to one another; unequal, when they are inclined at different angles. 3d, Solid angles, formed by the meeting of three or more faces; and in this case also there are similar and dissimilar, equal and unequal solid angles, according as they are formed by similar or dissimilar faces, and equal or unequal angled edges. The angles of crystals are measured by an instrument called the goniometer.

Crys'talline Rocks, rocks of a crystalline texture, such as granite, believed to have acquired this character by the action of heat and pressure.

Crystalloid. See *Dialysis*.

Crystal'omancy, a mode of divining by means of a transparent body, as a precious stone, crystal globe, &c. The operator first muttered over it certain formulas of prayer, and then gave the crystal (a beryl was preferred) into the hands of a young man or virgin, who received an answer from the spirits within the crystal.

Crystal Palace, the building erected 1852-54 at Sydenham, near London, from the materials, and in part after the design of the Great Exhibition building of 1851, and originally designed as a great educational museum of art, natural history, ethnology, &c. It is composed entirely of glass and iron, and consists of a long and lofty nave intersected at regular distances by three transepts, of which the central is 384 feet long, 120 feet wide, and 168 feet interior height. It lies in about 200 acres of ground excellently laid out for recreation, and possesses many permanent attractions apart from the annual

round of concerts, flower-shows, pyrotechnical displays, &c. Chief among these is the collection of casts of architectural ornaments and sculpture, arranged in the Egyptian, Greek, Roman, Alhambra, Byzantine, Mediæval, Renaissance, and Italian Courts. The building and grounds, which cost the Crystal Palace Company about £1,500,000, have scarcely answered the expectations of the projectors.

Csaba (chá'bá), a town of Hungary, about 110 miles s.e. of Budapest, near the White Körös. Pop. 32,616.

Csongrad (chon'grád), a market town, Hungary, at the junction of the Körös with the Theiss, 72 miles s.e. of Budapest. Trade: cattle, cereals, wines, &c. Pop. 17,837.

Ctenoid (ten'oid), applied to the scales of fishes when jagged or pectinated on the edge like the teeth of a comb, as in the perch, flounder, and turbot.

Ctenoph'ora, an order of marine animals belonging to the sub-kingdom Cœlenterata, definable as transparent, oceanic, gelatinous Actinozoa, swimming by means of *ctenophores*, or parallel rows of cilia disposed in comb-like plates. They develop no coral. *Pleurobrachia* (or *Cydippe*) may be taken as the type of the order, which includes the Beroidæ, the Cestum or Venus's girdle, &c.

Cte'sias, a Greek historian of about 400 B.C., contemporary with Xenophon and partly with Herodotus. He was a physician, and lived for seventeen years at the court of Persia. He wrote a History of Persia, of which little remains.

Cuba, the largest and most western of the W. India Islands, lying at the entrance to the Gulf of Mexico; about 130 miles from Florida and Yucatan. Its length is 750 miles, the breadth varying from 20 to over 120 miles; area 45,881 miles. It formed the richest and most important colony belonging to Spain, but was rent from that country by the U. S. in the war of 1898. The island probably had its origin in volcanic action, the Copper Mountains, which run its entire length, clearly demonstrating this. Pico Turquinos is the highest summit, being 7750 feet. From the base of this chain of high land the land expands into meadows with numerous lagoons and swamps. The rivers are small and unnavigable. Good harbors abound with deep water at Havana, Matanzas, Puerto Principe, Santiago, etc.

The climate in the hilly districts is generally healthful and agreeable, but the

lowlands are sickly and generally hot. The max. temperature seldom exceeds 88° F., but the heat is constant, the mean temp., in the lowlands, being 78°. The climate is moist, the rainfall being about 90 inches; yet some portions of the interior require irrigation. There are occasional hurricanes and earthquakes. Rain often descends in torrents from July to September, but no snow is known to fall on the highest mountains, though frost occurs occasionally.

The most valuable domestic animals are the ox, horse, and pig, which form a large proportion of the wealth of the island; the sheep, goat, and mule are inferior in quality and number. The sylvan birds are numerous and in great variety, birds of prey are but few, and snakes and reptiles are not very plentiful. The shores abound in turtle, and alligators are found in the deep gulfs and bays.

Cuba is rich in minerals; those worked are mostly iron and copper. Of the former a vast quantity is exported to the U. S. for admixture with the native ores. Bitumen is plentiful as a liquid and also in a plastic resinous state. Gold, silver, coal and marble are found in the hilly country. Forests of mahogany, rosewood, cedar, ebony, fustic, palms, etc., abound on the mountains. Large crops of tobacco, sugar, rice, maize, bananas, cotton, coffee, yams, and all tropical fruits, together with immense herds of cattle, are raised. Tobacco forms the leading export, sugar having much fallen off by the competition of the beet-sugars of continental Europe and the unsettled state of the island.

The manufacture of sugar, molasses, rum and cigars forms the principal industries. About 1000 miles of railway are in operation and 3000 miles of telegraph, with 159 telegraph offices. The Roman Catholic religion was established by the Spanish law; education was made compulsory in 1880, but was not impartially carried out. There are 860 public schools, beside a few schools in the towns and a university at Havana. None of the aboriginal race remain, and but few of the indigenous mammals; of the latter are two species of aguti and an opossum.

Cuba was discovered October, 1492, by Columbus, the Spaniards colonized it 1511; Hernando, the governor, cruelly treated the natives, an inoffensive race who had received their oppressors with great hospi-

CUBATURE OF A SOLID — CUCKOO.

tality, and in 1553 the entire race became extinct. In 1553 the French destroyed Havana; it was rebuilt and strongly fortified 1554. In 1624 taken by Dutch but soon restored to Spain. From 1650 to 1700 ravaged by filibusters, who, 1688, plundered and destroyed Puerto Principe. After 1700 Cuba prospered greatly. The English, with American colonists, captured Havana 1762, but 1763 exchanged it for other possessions. It now became the centre of the slave-trade. Negro insurrections occurred in 1844-48, and over 10,000 negroes were slain in latter. President Polk, under great Southern pressure, offered \$100,000,000 for Cuba; in 1854 the Ostend manifesto, signed by Buchanan, Soulé, and Mason, claimed the right to take and annex it if Spain should refuse to sell.

1868 commenced an insurrectionary attempt at independence and which continued until 1878. February 24, 1895, another revolution under Gomez, the Maceos and Garcia broke out. In April, 1898, war was declared by the U. S. against Spain, and in the struggle that ensued Cuba was freed from that yoke and passed under the domination of the U. S. The population of Cuba, including Isle of Pines and adjacent small islands, is 1,521,684. See *Spain's War*; viii., 378.

Cubature of a Solid, the finding of the solid or cubic contents of it.

Cube, in geometry, a regular solid body with six equal square sides. The solid content of any cube is found by multiplying the superficial area of one of the sides by the height; or, what comes to the same thing, by multiplying the number that expresses the length of one of the edges by itself, and the product thus found by that number again. Cubes are to one another in the triplicate ratio of their diagonals.—*Cube*, or *Cubic Number*, in arithmetic, that which is produced by the multiplication of a square number by its root; thus 64 is a cube number, and arises by multiplying 16, the square of 4, by the root 4.

Cu'bebs, the dried unripe fruit of *Cubēba officinālis*, or *Piper Cubēba*, a native of Java and other East India isles, order Piperaceæ. They resemble black pepper, and are globular, wrinkled, blackish-brown, with a warm, even acrid taste and peculiar odour. They have been used in medicine from the time of Hippocrates, and are still employed in diseases of the urinary system.

Cube Root, the number or quantity

which, multiplied into itself and then into the product, produces the cube; or which, twice multiplied into itself, produces the number of which it is the root: as 2 is the cube root of 8, because twice 2 are 4, and twice 4 are 8.

Cube-spar, an anhydrous sulphate of lime.

Cubic Foot of any substance, so much of it as is contained in a cube whose side is 1 foot.

Cubic Nitre, or **CHILI SALTPETRE**, the nitrate of sodium found chiefly in the rainless district of Tarapacá in Chili, where it occurs for the most part mixed with other salts, sand, and clay. It crystallizes in obtuse-angled rhombohedra, not in cubes, and is used in considerable quantities both as a dressing for grass and mixed in artificial manures. It has also been used as a source of nitric acid, and after double decomposition with chloride of potassium has been employed in the manufacture of gunpowder. The Peruvian and Chilian deposits are practically inexhaustible.

Cubit, in the mensuration of the ancients, a long measure, equal to the length of a man's arm from the elbow to the tip of the fingers, or, say equal to 18 inches.

Cucking-stool, a kind of chair formerly used as an instrument of punishment. Scolds, cheating bakers or brewers, and other petty offenders were placed in it, usually at their own doors, to be hooted at and pelted by the mob. It has been frequently confounded with the ducking-stool.

Cuck'oo (genus *Cucūlus*), a scansorial or climbing bird, the type of the family Cuculidæ. The note from which it derives its name is a love-call used only in the mating season. The greater number of species belonging to the genus are confined to hot countries, more especially India and Africa, though some are summer visitants of colder climates. In America no true cuckoos are found, the genus *Coccyzus*, to which the so-called American cuckoo belongs, differing very essentially from them in its habits. The species best known in Europe, the *Cucūlus canōrus*, is a bird about the size of a small pigeon, though the length of the tail gives it at a little distance a strong resemblance to a hawk. The adult bird is ashy-gray, with a white breast barred across with narrow lines of grayish black; tail spotted and barred with white; bill black, touched at the gape with yellow; eyes and feet yellow. It appears in England about the middle of

April, and in May begins to deposit its eggs in the nests of other species, giving the preference to those of the hedge-sparrow, meadow-pipit, or pied wagtail. The young



Cuckoo (*Cuculus canorus*).

cuckoo ejects from the nest its young companions, and monopolizes the attentions of its foster-parents, which feed it for about five weeks after it is fledged. The young birds do not leave the country until the end of August or even September; but the adult birds commence their flight southward in July or at latest early in August. Their food consists chiefly of cockchafers, moths, dragon-flies, and caterpillars, though young cuckoos will sometimes eat berries. There appears to be a curious preponderance of male as compared with female birds, a low estimate putting the ratio at about five to one.

Cuckoo-flower, or LADY'S-SMOCK (*Cardamine pratensis*), a common and pretty meadow plant, order Cruciferæ, with pale lilac or white flowers. *C. pratensis* is abundant in Britain, and is found in swamps N. of New York; blossoms in April or May, presenting a very pleasing appearance. It possesses antiscorbutic properties.

Cuckoo-pint, the *Arum maculatum*, popularly known also by the names of 'lords-and-ladies' or 'common wake-robin.' See *Arum*.

Cuckoo-spit, a froth or spume found on plants, being a secretion formed by the larva of a small homopterous insect (*Aphrophora spumaria*).

Cucu'lidæ, the systematic name of the cuckoo family. See *Cuckoo*.

Cu'cumber, the fruit of *Cucumis sativus*, or the plant itself, belonging to the Cucurbitaceæ or gourd order, and supposed to have been originally imported into Europe from the Levant. Though grown in England in the 14th century, it did not become generally used until after the reign of Henry

VIII. It is an annual with rough trailing stems, large angular leaves, and yellow male and female flowers set in the axils of the leaf-stalks. Other species of the cucumber genus are *Cucumis Melo*, the common melon, and the water melon, *C. Citrullus*.

Cucumber-tree (*Magnolia acuminata*), a fine American forest tree, so named from the appearance of its fruit.

Cucurbit. See *Alembic*.

Cucur'bita, the typical genus of the order Cucurbitaceæ. The pompion or pumpkin gourd is *C. Pepo*.

Cucurbita'ceæ, the gourd order, consisting of large herbaceous plants, annual or perennial, with alternate leaves palmately veined and scabrous, and unisexual flowers. The corolla is monopetalous, regular, and with five lobes; the petals, usually either yellow, white, or green, and deeply veined; the fruit fleshy and succulent. The stems are scabrous, and the general habit is climbing or trailing, by means of tendrils. The order contains at least fifty-six genera and about 300 known species, and abounds in useful or remarkable plants, including the melon, gourd, cucumber, colocynth, bryony, &c. They are natives of both hemispheres, chiefly within the tropics. The annuals, however, are common in our gardens.

Cud'bear, a purple or violet coloured powder used in dyeing violet-purple and crimson, prepared from the *Lecanora tartaræa* and other lichens growing on rocks in Sweden, Scotland, &c. The colour, however, is somewhat fugitive, and in Britain it is used chiefly to give strength and brilliancy to the indigo blues. There is little essential difference between cudbear and archil.



Cudbear Plant (*Lecanora tartaræa*).

Cuddalore', or KÚDALÚR, a maritime town in Hindustan, presidency of Madras and district of South Arcot, 86 miles s. of Madras. It was formerly a place of great strength and importance, and still carries on a large land trade with Madras in indigo, oils, and sugar. It also exports grain and rice. Pop. 43,545.

Cud'dapah, or KADAPA, a district and town, Hindustan, presidency Madras. The district, of which the area is 8745 square miles, is traversed N. to s. by the Eastern Ghauts, and watered by the Pennar and its affluents. The forests contain much valuable timber, and the minerals include iron

ore, lead, copper, diamonds, &c. Agriculture is in a flourishing condition, grain, cotton, and indigo being largely grown. Pop. 1,121,038.—The town lies on a small river of same name, an affluent of the Penar, 140 miles N.W. Madras. It exports indigo and cotton. Pop. 18,982.

Cud'weed, the popular name in Britain for certain plants covered with a cottony pubescence, and belonging to the genera *Gnaphalium*. *G. polycephalum*, the Cottonweed, common in fields in the United States.

Cudworth, RALPH, English divine and philosopher, born in 1617. He took his degree and fellowship at Cambridge in 1639; in 1644 was chosen master of Clare Hall; in the following year regius professor of Hebrew; and in 1654 master of Christ's College, Cambridge, where he spent the rest of his life. In 1678 he published his *True Intellectual System of the Universe*; wherein all the Reason and Philosophy of Atheism is confuted, and its Impossibility demonstrated (folio)—a work of an exceedingly erudite kind, though tediously discursive in argument. He died in 1688.

Cuen'ca, a city of Spain, in New Castile, capital of Cuenca province, 85 miles E.S.E. Madrid. Pop. 7916. It was built by the Moors, stands on a craggy hill, and has a remarkable cathedral. Pop. of the province, 244,915; square miles, 6726.

Cuen'ca, a town of Ecuador, next to Quito the most important in the country, with a cathedral and university. Pop. 30,000.

Cue'va, JUAN DE LA, a Spanish poet, born about the middle of the 16th century. His works comprise several tragedies, a heroic poem, a large number of lyrics and ballads, and the first Spanish didactic poem—on *Art of Poetry*. No details are known of his life.

Cufic, a term derived from the town of Cufa or Kufa in the pashalic of Bagdad, and applied to a certain class of Arabic written characters. The Cufic characters were the written characters of the Arabian alphabet in use from about the 6th century of the Christian era until about the 11th. They are said to have been invented at Cufa, and were in use at the time of the composition of the Koran. They were succeeded by the Neskhî characters, which are still in use. Under the name of *Cufic coins* are comprehended the ancient coins of the Mohammedan princes, which have been found in modern times to be important for illustrating the history of the East. They are of

gold (*dinar*), silver (*dirhem*), and brass (*fals*), but the silver coins are most frequent, and numbers of them have been discovered on the shores of the Baltic, and in the central provinces of European Russia.

Cuirass (kwi-ras'), an article of defensive armour, protecting the body both before and behind, and composed of leather, metal, or other materials variously worked. It was in common use throughout Europe in the 14th century. In England it fell into disuse in the time of Charles II., and in France a little later. It was reintroduced by Napoleon I., and the achievements of his cuirassiers led to its adoption for regiments of heavy cavalry in most European armies. In the British army only the 1st and 2d Life Guards and Royal Horse Blue wear the cuirass. See *Arms and Armour*.

Cuir-bouilly (kwër'bö-i-li), leather softened by boiling, then impressed with ornaments, used for shields, girdles, sword-sheaths, coffers, purses, shoes, and many other articles; also, in the 16th century, for hangings for rooms gilded and painted, and, when heightened by gold or silver, known as *cuir doré* or *cuir argenté*.

Cuishes, or CUISSÉS (kwish'es, kwis'ez), defensive armour for the thighs, originally of buff leather, which was gradually superseded by plate iron or steel. Cuishes were introduced into England about the middle of the 14th century.

Cujas, JACQUES, or CUJACIUS, a distinguished French jurist, born about 1520; long professor of law at Bourges, died in 1590. He owed his reputation to the light shed by him on Roman law. He was the founder of the historic legal school, if not of scientific jurisprudence.

Culdees', a religious order which at an early period had establishments in many parts of Great Britain and Ireland, but are especially spoken of in Scotland. The name is of uncertain etymology; but is probably from Celtic words meaning 'attendant of God.' It first appears in the 8th century, and the Culdees distinctively so called seem to have been anchorites living under their own abbots, and for long remaining independent of Rome. Otherwise archaeologists have discovered no essential point either of faith, ritual, or constitution in which they differed from the other clergy of the western church.

Culi'cidæ, a sub-family of dipterous insects, family Tipulidæ. The genus *Culex* comprehends the common gnat and the mosquito.

CULILAWAN BARK — CUMÆ.

Culil'awan Bark, a valuable aromatic pungent bark, the produce of *Cinnamōmum Culilawan*, a tree of the Moluccas, useful in indigestion, diarrhoea, &c. Called also clove-bark.

Cullen, a parliamentary and royal burgh and seaport of Scotland, county of Banff. Pop. of royal burgh, 3682; of parl. burgh, 2033.

Cullen, WILLIAM, physician and medical writer, born at Hamilton, Lanarkshire, in

1710. In 1740 he took the degree of M.D., was appointed in 1746 lecturer on chemistry at the University of Glasgow, and in 1751 regius professor of medicine. In 1756 he was invited to take the chemical professorship in the University of Edinburgh, and in 1760 was made lecturer on the *materia medica* there. In 1773 he succeeded Dr. Gregory in the chair of the practice of physic. His death took place in 1790. His principal works are: Lectures



Culloden Moor, looking towards the Beaully Firth.

on the *Materia Medica*; *Synopsis Nosologiæ Methodicæ*; and the *First Lines of the Practice of Physic*.

Cullera (kūl-yā'ra), a town, Spain, province and 25 miles s. by e. of Valencia. Pop. 9814.

Cullo'den Moor, a heath in Scotland, 4 miles e. of Inverness, celebrated for the victory obtained April 27, 1746, by the Duke of Cumberland over Prince Charles Edward Stuart (the Pretender) and his adherents. The battle was the last fought on British soil, and the termination of the attempts of the Stuart family to recover the throne of England.

Culm. See *Kulm*.

Culm, in bot. the jointed and usually hollow stem of grasses, generally herbaceous, but woody and tree-like in the bamboo.

Culmination, in astronomy, the passing of a star through the meridian, because it has at that moment reached the highest

point (*culmen*) of its apparent path in the sky.

Culna. See *Kalna*.

Culross (kō'ros), a parliamentary and royal burgh (one of the Stirling burghs), Scotland, county Perth, on the north shore of the Forth. Pop. 373.

Cultivator, an agricultural implement with long, strong, broad-pointed iron teeth or tines, for tearing up or loosening the soil; also called a horse-hoe.

Cul'verin, a long and slender cannon used in the 16th century. It generally carried a ball of about 18 lbs.; the demi-culverin carried one of about half that weight.

Cu'mæ, a very ancient city of Italy, in Campania, the oldest colony of the Greeks in Italy, founded about 1030 B.C. by colonists from Chalcis, in Eubœa, and from Cyme (Greek, *Kumē*) in Asia Minor. It founded Naples (Neapolis), and in Sicily Zancle or Messina. In 420 B.C. Cumæ was taken by the

CUMANA — CUMBRAE.

Campanians, and came with them under the power of Rome (345 B.C.). It was destroyed A.D. 1207, and a few ruins only now exist.

Cumana', a town of Venezuela. It is the oldest European city in the New World, having been founded in 1523. It lies near the mouth of the Gulf of Cariaco, and has a good roadstead in Cumana Bay, with a trade in cacao, sugar, tobacco, &c. Pop. 12,051.

Cum'berland, the extreme north-western county of England. Length, north to south, 75 miles; extreme breadth, 45 miles; area, 970,161 acres, rather more than a half of which is under cultivation. There is great variety of surface in different parts. Two ranges of lofty mountains may be traced—one towards the north, to which belongs the ridge called Crossfell (2892 ft.); and the other to the south-west, of which the highest peak is Skiddaw (3058 ft.). Other important summits are: Scaw Fell Pikes (3210 ft.), Scaw Fell (3162 ft.), Helvellyn (3118 ft.), and Bow Fell (2960 ft.). The two largest rivers are the Eden and the Derwent. The county embraces part of the 'Lake Country' of England. The largest lakes are Derwentwater, Bassenthwaite, Loweswater, Crummock, Buttermere, Ennerdale, Westwater, Thirlmere, and part of Ullswater. Cumberland is rich in minerals, including lead, gypsum, zinc, and especially coal and rich hematite iron-ore. In the western division of the county there are a great many blast-furnaces, and works for the manufacture of steel and finished iron. The principal crops raised are oats, barley, wheat, and turnips, but the bulk of the inclosed lands is sown in clover and grass. The rearing of cattle and sheep and dairy farming are engaged in to a considerable extent. Carlisle is the county town; the other principal towns are the seaports Whitehaven, Workington, and Maryport; and the inland towns Penrith, Cockermouth, and Keswick. Pop. 266,550. Sends 4 members to Parliament.

Cumberland, Providence co., R. I.; a manufacturing town. Pop. 1890, 8090.

Cumberland, a city of the U.S., the seat of Alleghany county, Maryland, on the Potomac, 179 miles by rail from Baltimore. It is on the edge of the great coal-basin of the same name, and iron is also largely worked in the vicinity. Pop. 1890, 12,729.

Cumberland, a river of the U. States which runs through Kentucky and Tennessee into the Ohio, having a course of about 600 miles, navigable for steam-boats to Nashville, near 200 miles.

Cumberland, RICHARD, dramatic and miscellaneous writer, born at Cambridge 1732. After studying at Westminster and Cambridge he became private secretary to Lord Halifax, who bestowed on him a few years later a clerkship of reports in the office of trade and plantations. After one or two failures in writing for the stage, his *West Indian*, brought out by Garrick in 1771, proved eminently successful, and it was followed by the less popular *Fashionable Lover*, *The Choleric Man*, *The Note of Hand*, and *The Battle of Hastings*. In 1775 he became secretary to the board of trade, and in 1780 was employed on a mission to Lisbon and Madrid, but failing to satisfy the ministry was compelled to retire. His subsequent works include his *Anecdotes of Spanish Painters*, the *Observer*, the novels of *Arundel*, *Henry* and *John de Lancaster*, the poem of *Calvary*, the *Exodiad* (in conjunction with Sir James Bland Burgess), a poem called *Retrospection*, and the *Memoirs of his own Life*. He also edited the *London Review*. He died in 1811.

Cumberland, WILLIAM AUGUSTUS, DUKE OF, second son of George II. of England, born in 1721. At the battle of Dettingen he was wounded when fighting at the side of his father, and though unsuccessful at Fontenoy, where he had the command of the allied army, he rose in reputation by somewhat brutally subduing the insurrection in Scotland caused by the landing of Charles Edward Stuart in 1745. In 1747 Cumberland was defeated by Marshal Saxe at Lafeld, and in 1757 he lost the battle of Hastenbeck, against D'Estrées, and concluded the convention at Closterseven, by which 40,000 English soldiers were disarmed and disbanded, and Hanover placed at the mercy of the French. He then retired in disgrace from his public offices, and took no active part in affairs. He died in 1765.

Cumberland Mountains, in Tennessee, part of a range of the Appalachian system, rarely exceeding 2000 feet in height.

Cumberland Presbyterians, a small American sect, so named from the Cumberland country in Tennessee, founded early in the present century, and holding Calvinistic doctrines, except regarding predestination. Organizations, 2791; value of church property, \$3,515,511; members, 164,910.

Cum'brae, or CUMBRAE, the GREATER and LESSER, two Scottish islands in the Firth of Clyde, belonging to the county of Bute.

The Greater Cumbrae is $3\frac{3}{4}$ miles in length and 2 in breadth; area, $3120\frac{1}{2}$ acres. The only town upon it is Millport, a seaside resort. The Lesser Cumbrae is $1\frac{3}{4}$ mile in length by a mile in breadth; area, 700 acres. Pop. of the Greater Cumbrae, 1856; of the Lesser, 23.

Cum'bria, an ancient British principality, comprising, besides part of Cumberland, the Scotch districts Galloway, Kyle, Carrick, Cunningham, and Strathclyde, its capital being Alcluyd or Dumbarton. It was possibly at one time the chief seat of the power of Arthur, and in the 6th century was an important and powerful kingdom. It speedily, however, fell under Saxon domination, and early in the 11th century was given by Edmund of Wessex to Malcolm of Scotland to be held as a fief of the crown of England. The name still survives in Cumberland.

Cumbrian Mountains, a range of hills, England, occupying part of the counties of Cumberland, Westmoreland, and North Lancashire. The mountains rise with steep acclivities, inclosing in some parts narrow but well-cultivated valleys, with numerous picturesque lakes, this being the English 'Lake Country' so much frequented by tourists.

Cum'in, or CUM' MIN, an umbelliferous plant (*Cuminum Cyminum*) which grows wild in Egypt and Syria, and is largely cultivated in Sicily and Malta, whence it is exported. The fruit, called cumin seeds, is of a light-brown colour, with an aromatic smell and caraway-like taste, and possesses stimulating and carminative properties.

Cumming, REV. JOHN, D.D., born in 1810 at Aberdeen, where he graduated. At the age of twenty-two he became minister of the Scotch Church, Crown Court, Covent Garden, London, where he laboured for half a century, publishing during that period over two hundred works. He had a high reputation as an orator, but he was most widely known latterly in connection with his prophecies of the speedy coming of the end of all things. His most popular works were: *The Great Tribulation*, *The Redemption Draweth Nigh*, *Apocalyptic Sketches*, *Voices of the Night*, *Signs of the Times*, &c.

Cumming, ROUALEYN GEORGE GORDON, the 'Lion-hunter,' a Scottish sportsman and writer, born in 1820, died at Fort Augustus, in Scotland, in 1866. He entered the army, served some years in India, joined the Cape Rifles, and from 1843 till 1849 made five

hunting expeditions into various parts of Africa. On his return to England he exhibited his collection of trophies in London and elsewhere, finally establishing it at Fort Augustus. Records of his adventures are to be found in his *Five Years of a Hunter's Life* (1850), and the *Lion-hunter of South Africa* (1856).

Cumquat. See *Kumquat*.

Cu'mulative Vote, the system by which every voter is entitled to as many votes as there are persons to be elected, and may give them all to one candidate, or may distribute them among the candidates, as he thinks fit. The principle was first introduced into Britain by the Elementary Education Act of 1870, but it is not recognized in any elections save those of the school-boards.

Cum'yn, COMYN, or CUMMING, a family whose name appears frequently in the early history of England and Scotland. It had its original possessions near the town of Comines in France, and from one of the branches sprang the historian Philip de Comines. The English Comyns came over with the Conqueror, and Robert Comyn was sent by William with 700 men to reduce the northern provinces. His nephew became chancellor of Scotland about 1133, and in the middle of the 13th century the family counted among its members four Scottish earls. In the beginning of the 14th century it was almost annihilated by Robert Bruce, who slew the son of its head (the Lord of Badenoch) in Dumfries. The Comyns who escaped settled down in the English court, and established important connections. See *Comyn*.

Cundinamarca, one of the departments of the Republic of Colombia. Area, estim. 79,810 square miles; pop. 537,658.

Cune'iform Writing (Lat. *cuneus*, a wedge, and *forma*, a shape), the name applied to the wedge-shaped characters of the inscriptions on old Babylonian and Persian monuments; sometimes also described as *arrow-headed* or *nail-headed* characters. They appear to have been originally of the nature of hieroglyphs, and to have been invented by the primitive Accadian inhabitants of Chaldea (a Turanian race), from whom they were borrowed with considerable modification by the conquering Babylonians and Assyrians, who were Semites by race and spoke an entirely different language. The use of the character, however, ceased shortly after the reign of Alexander the

Great; and after the lapse of nearly two thousand years it was doubted by many if the signs had ever had an intelligible meaning. They were even regarded by some as the work of a species of worm, by others as mere talismanic signs, astrological symbols, and the like. The first hints towards decipherment were given by Karstens Niebuhr late in the 18th century; and the labours of Grotefend, Rask, Burnouf, Lassen, Rawlinson, and other investigators slowly perfected the means of translation. Most of the inscriptions first discovered were in three different languages and as many varieties of cuneiform writing, the most prominent, and at the same time the simplest and latest, being the Persian cuneiform writing with about sixty letters. Next older in time and much more complex

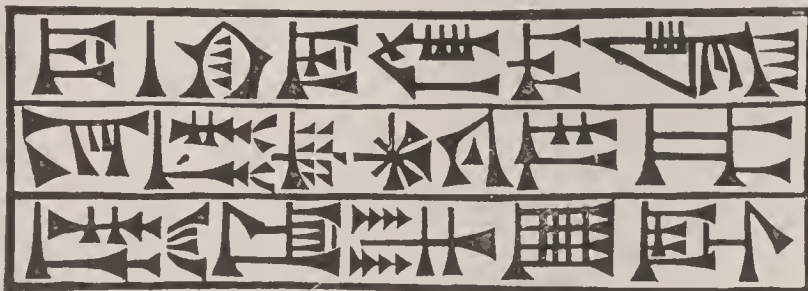

Part of a Babylonian Brick with Cuneiform Writing.

is what is designated the Assyrian or Babylonian system of writing, consisting of from 600 to 700 characters, partly alphabetic, partly syllabic, or representing sound groups. Lastly comes the Accadian inscriptions, the oldest of all, originally proceeding from a people who had reached a high state of civilization three thousand years before Christ, and whose language (allied to Turkish) ceased to be a living tongue about 1700 B.C. The most celebrated trilingual inscription is that at Behistun, cut upon the face of a rock 1700 feet high, and recording a portion of the history of Darius. The British Museum contains many thousands of inscribed clay tablets, cylinders, prisms, &c., the decipherment of which is in progress. See also *Assyria*.

Cune'ne, a river of South Africa, which enters the Atlantic after forming the boundary between the Portuguese and German territories here.

Cu'neo. See *Coni*.

Cunningham, the northern and most fertile district of Ayrshire, Scotland.

Cunningham, ALLAN, poet, born in 1785 at Blackwood in Dumfriesshire; apprenticed in his eleventh year to a stone-mason. Having been employed by Cromek to collect materials for his *Remains of Nithsdale and Galloway Song*, he sent instead his own productions, which were printed, but quickly

recognized as being forgeries. He then proceeded to London, where he at first supported himself by journalism, but afterwards obtained a situation in the studio of Chantrey, with whom he remained till his death. His later works comprise the drama of *Sir Marmaduke Maxwell*; the novels of *Paul Jones* and *Sir Michael Scott*; the *Songs of Scotland*; his *British Painters, Sculptors, and Architects* (1829); and lives of Burns and of Mary Queen of Scots. He died at London in 1842.—His son PETER (1816-69) is also known as the author of a series of works, including *The Story of Nell Gwynne*, *Life of Drummond of Hawthorn-*

den, *Modern London*, *Life of Inigo Jones*, &c. He also edited *Walpole's Letters*, *Goldsmith's Works*, &c., and contributed to many periodicals and magazines.

Cupar, or CUPAR-FIFE (kŏ'pär), a royal and parliamentary burgh of Scotland, county town of Fifeshire, on the river Eden, 10 miles west from St. Andrews. Pop. 5010.

Cupar-Angus. See *Coupar-Angus*.

Cu'pel, a small shallow, porous, cup-like vessel, used in assays, to separate the precious metals from their alloys. See *Assaying*.

Cu'pid (Lat. *Cupido*), the god of love; corresponding with the Greek Erōs. He is represented as a winged infant, naked, armed with a bow, and a quiver full of arrows.

Cu'pola, in architecture, a spherical vault on the top of an edifice; a dome or the round top of a dome. The Italian word *cupola* signifies a hemispherical roof which covers a circular building, like the Pantheon at Rome and the Round Temple of Vesta at Tivoli. The term is also applied distinctively to the concave interior as opposed to the dome forming its exterior. See *Dome*.

Cupping, a surgical operation consisting in the application of the cupping-glass in cases where it is desirable to abstract blood from, or draw it to, a particular part. When blood is removed the operation is simply termed *cupping*; when no blood is abstracted, it is *dry-cupping*. The cupping-glass, a cup-shaped glass vessel, is first held over the flame of a spirit-lamp, by which means the included air is rarefied. In this state it is applied to the skin, and as the

heated air cools it contracts and produces a partial vacuum, so that the skin and integuments are drawn up slightly into the glass and become swollen. If blood is to be drawn, a scarificator or spring-lancet is generally used.

Cupressus. See *Cypress*.

Cupulif'eræ, a botanical order, so named from the peculiar husk or cup (*cupule*) in which the fruit is inclosed. They are trees or shrubs, inhabiting chiefly the temperate parts of the northern hemisphere, and common in Europe, Asia, and North America. The chief genera are the oak, chestnut, beech, and hazel.

Cur, the name loosely given to any worthless dog of mongrel breed, but applied more strictly to a cross between the sheep-dog and terrier.

Curaçao (*kō-râ-sä'ō*), an island, Dutch West Indies, Caribbean Sea, 46 miles N. the coast of Venezuela; 36 miles long and 8 miles broad; capital Willemstad, principal harbour Santa Anna. It is hilly, wild, and barren, with a hot dry climate. Yellow fever visits it every sixth or seventh year. Fresh water is scarce, and serious droughts occur. The tamarind, cocoa-palm, banana, and other useful trees are reared—among them three varieties of orange, from one of which the Curaçao liqueur is made. Sugar, tobacco, cochineal, and maize are also produced, but the staple exports are salt, and a valuable phosphate of lime used as a manure in its natural state, or made to yield valuable superphosphates. The islands of Curaçao, Bonaire, Oruba (or Aruba), and Little Curaçao, form a Dutch government, the residence of the governor being at Wilhelmstad. From the 16th century Curaçao was held in succession by the Spaniards, Dutch, and British, and finally ceded to Holland at the general peace in 1814. Pop. 25,421; including the dependencies, 44,734.

Curaçao, or **CURAÇOA**, a liqueur or cordial prepared from a peculiar kind of bitter oranges growing in Curaçao, which have a persistent aromatic odour and taste. It is prepared from the yellow part of the rind, which is steeped in strong alcohol, the infusion being afterwards distilled and rectified and mixed with syrup. For the true orange, the common bitter orange of Europe is often substituted, and the genuine deep-yellow colour imitated by caramel, &c.

Cu'rari, **CU'RARA**, **URARA**, **WOORALI**, the well-known arrow-poison of the Indians in Spanish Guiana and in Northern Brazil. It

is the aqueous extract of a tree, the *Strychnos toxifera*, thickened with mucilaginous matter; and its properties are such that if introduced into a scratch or puncture of the skin, so as to mix with the blood, it causes death by paralysis of the nerves of the respiratory organs. It may, however, be introduced in moderate doses into the alimentary canal without injury, and animals killed by it are wholesome as food. The active principle is called *curarin*.

Curas'sow, or **Hocco**, the name given to gallinaceous birds of the genus *Crax*, family Cracidæ; natives of the warm parts of America. The crested curassow (*Crax alector*),



Crested Curassow (*Crax alector*).

found in Guiana, Mexico, and Brazil, is a handsome bird, nearly as large as the turkey and more imposing in appearance, being of a dark violet colour, with a purplish-green gloss above and on the breast; the abdomen is snow-white, and the crest golden. Another species is the red curassow (*Crax rubra*), also a native of South America, and about the size of a turkey. The cushew-bird (*Urax pauxi*) is called the galeated curassow.

Cu'rate, properly an incumbent who has the care of souls; now generally restricted to signify the substitute or assistant of the actual incumbent. In the Church of England curacies are either *stipendiary* or *perpetual*. A stipendiary curate is one who is hired by the rector or vicar to serve for him and may be removed at pleasure; a perpetual curate is one who is not dependent on the rector, but is supported by a part of the tithes or otherwise. By law the lowest stipend to be paid to a curate is £80, the sum rising, in proportion to the population of the cure, to £150 as a maximum.

Cura'tor, in civil law, the guardian of a minor who has attained the age of fourteen, of persons under various disabilities, or of the estate of deceased or absent persons and insolvents.—In learned institutions the person who has charge of the library or collections of natural history, &c., is often called the curator.

Curb, the general term for a hard and callous swelling on various parts of a horse's leg, as the hinder part of the hock, the inside of the hoof, beneath the elbow of the hoof, &c.

Curb-roof, in architecture, a roof in which the rafters, instead of continuing straight down from the ridge to the walls, are at a given height received on plates, which in their turn are supported by rafters less inclined to the horizon, so that this kind of roof presents a bent appearance, whence its name. Called also a *Mansard Roof*, from the name of its inventor.

Curb-sender, an automatic signalling apparatus invented by Sir W. Thomson of Glasgow and Prof. Fleeming Jenkin of Edinburgh, and used in submarine telegraphy. The message is punched on a paper ribbon, which is then passed through the transmitting apparatus by clock-work. The name is due to the fact that when a current of one kind of electricity is sent by the instrument another of the opposite kind is sent immediately after to curb the first, the effect of the second transmission being to make the indication produced by the first sharp and distinct, instead of slow and uncertain.

Curcas. See *Physic-nut*.

Curculion'idæ, the weevils or snout-beetles, one of the most extensive families of coleopterous insects. See *Weevil*.

Cur'cuma, a genus of plants of the ginger family, of which *C. longa* yields turmeric, *C. zedoaria*, zedoary.

Curd. See *Cheese and Milk*.

Curdee - cil, safflower oil.

Cur'few (Fr. *couvre-feu*, cover fire), a practice originated in England by William the Conqueror, who directed that at the ringing of the bell at eight o'clock all fires and lights should be extinguished. The law

was repealed by Henry I. in 1100, but the bell continued to be rung in many districts to modern times, and probably may still be heard. The name was also given formerly to a domestic utensil for covering up a fire.

Cu'ria, anciently one of the thirty divisions of the Roman people, which Romulus is said to have established; also the place of assembly for each of these divisions. The *comitia curiata* was the assembly of the people in curiæ. See *Comitia*.

Curia, PAPAL, in its stricter sense the authorities which administer the Papal primacy; in its common wider use all the authorities and functionaries forming the Papal court. The different branches of the curia having respect to church government are the sacred congregation of cardinals, the secretariat of state, and the vicariate of Rome, the machinery employed being supplied by the chancery, the dataria, and the camera apostolica. As 'supreme judge' in Christendom the pope acts through special congregations and delegated judges, or through the regular tribunals of the rota and segnatura, and the penitenziaria. The institution of the Papal chapel and the household of the pope (*Famiglia Pontificia*) are also classed as departments of the curia; and finally the functionaries maintaining the external relations of the pope—legates, nuncios, apostolic delegates, &c. Formerly the curia included besides these the mechanism and functions of secular administration.

Curiatii. See *Horatii*.

Curico', a town of Chile, capital of prov. of same name. Pop. 9000. Area of prov. 2913 sq. miles; pop. 102,647.

Curisches Haff. See *Kurisches Haff*.

Curiti'ba, a town of S. Brazil, capital of the prov. of Parana, connected by railway with the port of Paranagua. Pop. 10,000.

Curlew (*Numenius*), a genus of birds belonging to the order Grallatores, or Waders, and of the same family (*Scolopacidae*) as the snipe and woodcock. The genus is characterized by a very long, slender, and arcuated bill, tall and partly naked legs, and a short somewhat rounded tail. The bill is more or less covered with a soft sensitive skin by which the bird is enabled to detect its food in the mud. Two species of curlew inhabit the British Isles, the curlew proper, called in Scotland the 'whaup' (*Numenius arquata*), and the whimbrel (*N. phaeopus*). They are similar in appearance and in habits, only the latter is rather smaller than the former, being about 17 inches long, while the curlew



Curfew for Fire.—Demmin's
Encyc. des Beaux Arts.

CURLING — CURRANTS.

is about 2 feet. The plumage is generally dull, being grayish-brown, rusty-white, and blackish, in both sexes, which are similar in size. They feed on various worms, small fishes, insects, and molluscous animals, and are very shy, wary birds. Three species of curlew are inhabitants of America—the long-billed curlew (*N. longirostris*), about 29 inches long, with a bill 7 to 9 inches in length; the Hudsonian, or short-billed curlew (*N. Hudsonicus*); and the Esquimaux curlew (*N. borealis*).

Curling, a favourite Scottish winter amusement on the ice, in which contending parties slide large smooth stones having somewhat the shape of a flattened hemi-

sphere, weighing from 30 to 45 lbs. each, with an iron or wooden handle at the top, from one mark to another. The space within which the stones move is called the *rink*, and the hole or mark at each end the *tee*. The length of the rink from tee to tee varies from 80 to 50 yards. The players are arranged in two parties, each headed by a *skip* or director. The number of players upon a rink is eight or sixteen—eight when the players use two stones each, and sixteen when they use one stone each. There may be one or more rinks according to the number of curlers. The object of the player is to lay his stone as near to the mark as possible, to guard that of his partner which has

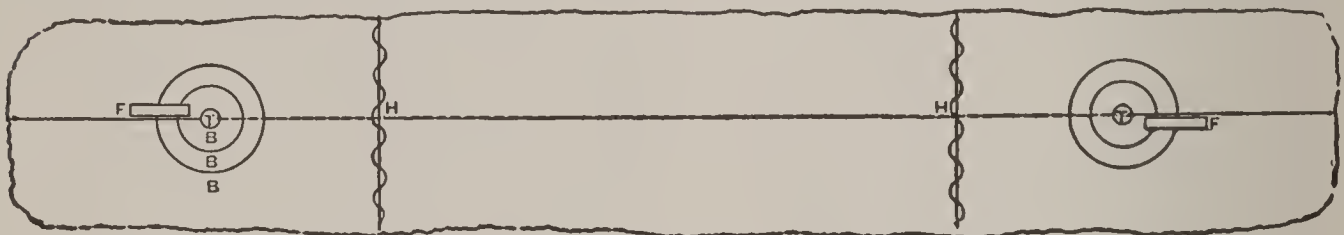

Curling Rink. T, Tee. B B, Rings round Tee called the Trough. F, Footboard. H, Hog-score.

been well laid before, or to strike off that of his antagonist. When the stones on both sides have been all played the stone nearest the tee counts one, and if the second, third, fourth, &c., belong to the same side, each counts one more, the number played for being generally twenty-one. If a player's stone does not cross a line, called the *hog-score*, at some distance in front of the tee his shot goes for nothing and the stone is removed from the rink. The set matches are termed *bonspiels*. The game is now played in England, Canada, and elsewhere.

Curr'agh, a plain or common in Ireland, co. Kildare, the property of the crown and the site of the chief military encampment in Ireland, formed in 1855, and having accommodation for 12,000 troops.

Cur'ran, JOHN PHILPOT, Irish advocate and politician, born at Newmarket, near Cork, in 1750. He was educated at Trinity College, Dublin, went to London, was called to the bar, and during the administration of the Duke of Portland obtained a silk gown. In 1784 he was chosen a member of the Irish House of Commons. His eloquence, wit, and ability soon made him the most popular advocate of his age and country. On a change of ministry during the viceroyalty of the Duke of Bedford his patriotism was rewarded with the office of master of the rolls, which he held till 1814, when he

retired with a pension of £3000 a year. He died at Brompton in 1817. A collection of his forensic speeches was published 1805.

Cur'rant, the name of two well-known shrubs, order Grossulariaceæ, cultivated in gardens for their fruit. The red currant, *Ribes rubrum*, the fruit of which is used principally for tarts and jellies, is a native of S. Europe, Asia, and N. America. The white currant is a cultivated variety of the red, and is used chiefly for dessert and for conversion into wine. The black currant, *R. nigrum*, a native to most parts of Europe, and found abundantly in Russia and Siberia, is used for tarts and puddings and for a fine jelly recommended in cases of sore throat. Other currants naturalized in Britain are the ornamental *Ribes aurëum* from Western America, which produces a fine berry, and *R. sanguinëum*, the flowering currant, which is insipid but non-poisonous. Many species are indigenous in America. In Australia the name is given to *Leucopogon Richei*, one of the Epacridaceæ, and in Tasmania to certain species of *Coprosma*, of the nat. order Cinchonaceæ. The Indian currant of America is the snow-berry, *Symphoricarpos racemōsus*. See also *Currants*, where the origin of the name is given.

Currants (from *Corinth*, being brought from the adjoining parts of Greece), a small kind of dried grape imported from the Le-

CURRENT WINE—CURRENCY.

vant, chiefly from the vicinity of Patras in the Morea, as also from Zante, Cephalonia, and Ithaca, of which islands they are the staple produce. The plant is delicate and the crop precarious, and as the plantation must be six or seven years old before it bears, its cultivation requires a great outlay of capital. After being dried the currants are exported in large butts.

Currant Wine, a wine made of the juice of the white or red currant (preferably the former). A pint of water is added to every four pints of berries and afterwards a pound and a half of sugar to each pint, a little spirits being mixed in the liquor before it is set aside to ferment. Fermentation requires several weeks, and the wine is not fit for use for some months. For black-currant wine the berries are first put over the fire and heated to the boiling point in as small a quantity of water as possible.

Cur'ency, any medium of exchange by which the processes of trade are facilitated. Originally all exchanges may be supposed to have been made directly by barter, one commodity being exchanged against another according to the convenience of the particular holders. In barter, however, it would obviously be often difficult to find two persons whose disposable goods suited each other's needs, and there would also arise difficulties in the way of estimating the terms of exchange between unlike things, and of subdividing many kinds of goods in the barter of objects of different value. To obviate these some special commodities in general esteem and demand would be chosen as a medium of exchange and common measure of value, the selection varying with the conditions of social life. In the hunting state furs and skins have been employed by many nations; in the pastoral state sheep and cattle are the chief negotiable property. Articles of ornament, corn, nuts, olive-oil, and other vegetable products, cotton cloth, straw mats, salt, cubes of gum, bees'-wax, &c., have all been at various times employed to facilitate exchange. These, however, while removing some of the difficulties attendant upon barter would only partially solve others. It would be felt by degrees that any satisfactory medium must not only possess utility and value, but it must be portable, not easily destructible, homogeneous, readily divisible, stable in value, and cognizable without great difficulty. The metals would naturally commend themselves as best satisfying these

requirements, and accordingly in all historic ages gold, silver, copper, tin, lead, and iron have been the most frequent materials of currency. The primitive method of circulating them appears to have consisted simply in buying and selling them against other commodities by a rough estimation of the weight or size of the portions of metal. Sometimes the metal was in its native state (*e.g.* rough copper or alluvial gold-dust), at others in the form of bars or spikes, the first approximation to a coinage being probably rudely-shaped rings. The earliest money was stamped on one side only, and rather of the nature of stamped ingots than coins as we know them. The chief desiderata influencing the subsequent development of coinage were the prevention of counterfeiting, the prevention of any fraudulent subtraction of metal from the coin, the removal as far as possible of anything likely to occasion loss of metal in the wear and tear of usage, and the production of an artistic and historical monument of the state issuing the coin. Hence the elaboration of designs to cover the whole of a given portion of metal, and the nicer determination of quality, size, degree of relief, inscription, &c. While, however, metallic money of a guaranteed standard value was at an early period found to facilitate in a high degree the mechanism of exchange, it was speedily discovered that it was possible in large part to replace the standard gold or silver or copper coins by various forms of currency of a representative character. The standard money depended solely for its value in exchange upon the value of the material of which it was composed; its metallic value and its nominal value were coincident; the representative money derived its value from a theoretic convertibility at will into the standard coin. Thus in token coins the metallic value may be much less than the nominal value, which is defined by the fact that they can either by force of law or custom be exchanged in a certain fixed ratio for standard coins. Gradually a series of devices came to be employed to further the interchange of commodities with the least friction and the least possible actual use of the coinage except as a standard and common denominator of value in terms of which exchanges were made. Even in home transactions, but especially in international transactions, the use of actual specie was found to involve a loss of interest and a risk of still more serious loss, and a paper currency

CURRENCY.

based upon credit offered the readiest solution of the difficulty. In this way bank-notes, bills of exchange, and cheques—warrants or representative documents convertible, if desired, into standard coin—took their place alongside the metallic currency, partly displacing it, partly extending and supplementing it.

The requisites of circulation are that the monetary issues, whether of coin or paper, shall be from a recognized or official source, and that they admit of being freely returned when necessary to the source from which they are issued. The certification of the fineness of the masses of metal circulating in a community, and the protection from adulteration and fraud, clearly falls among the necessary acts of police. It is still argued, as by Herbert Spencer in his *Social Statics*, that the coinage should be left to the ordinary competition of manufacturers and traders; but when this has occurred the currency has uniformly become debased, and it is generally held, in accordance with the maxims of civil and constitutional law, that the right of coining is a prerogative of the crown. Even in the case of state-issues base money has been circulated, as in England in the reigns of Henry VIII. and Edward VI., but the attempt is little likely to be repeated, the last of such debased issues, with the refusal to redeem it at its nominal value, having been made by a petty German prince early in the century. In the matter of state supervision two precautions are particularly necessary: that the standard coins shall be issued as nearly as possible of the standard weight, and that all coin worn below the least legal weight shall be withdrawn from circulation. The ground for these precautions is to be found in the broad general principle relating to the circulation of money, and known as Gresham's Law, that bad money invariably drives good money out of circulation, the heaviest coins being selected for exporting, hoarding, melting, conversion into jewelry, gold-leaf, &c. The law holds good not only with regard to coins in one kind of metal, but to all kinds of money in the same circulation, the relatively cheaper medium of exchange being retained in circulation while the other disappears. Of the various systems of metallic currency the first adopted was that known as the single-legal-tender system, in which the state issued certified coins in one metal only. It was found, however, that in such cases the people invariably circulated

for convenience coins of other metals, and there naturally arose out of this the adoption of a double or multiple legal tender system, in which coins were issued in different metals at a fixed rate of exchange. To obviate difficulties arising from the possession of two or more metals as concurrent standards of value, with the constant tendency of one or other to become more valuable as metal than as currency, a third system, the composite-legal-tender, came into existence, in which coins of one metal were adopted as the standard of value, and token coins only issued in the other metals for the payment of small amounts. The last system is that now prevalent in Great Britain; but the double-legal-tender system, to which the French have long adhered, and which has been adopted in the United States, has found an increasing number of advocates for its universal adoption. See *Bimetallism*.

The circulation of representative money differs from that of standard metallic money in that it only circulates within the district or country where it is legally or habitually current. In the payment of debts to foreign merchants the only money which can be exported is standard metallic money. Hence Gresham's law holds with regard to paper-money, which is, like light and debased coins, capable of driving out standard money. Examples of this are to be found in the suspension of specie payments by the Bank of England between 1797 and 1819, and in the history of the French assignats at the time of the revolution. The various methods on which the issue of paper money may be conducted are exceedingly numerous and a matter of interminable debate. The state may either constitute itself the sole issuer of representative money on the same lines as it constitutes itself sole issuer of metallic money, or it may allow corporations, companies, or private individuals to issue representative money under legislative control.

The question as to the duty of a government in this respect has been much obscured by the want of a clear apprehension of the distinction between a real and a nominal currency. The doctrine of orthodox English writers on the currency of the absolute convertibility of the bank-note, by which is intended a convertibility provided for by the action of government, is held by some writers to proceed on an altogether exaggerated and inaccurate notion of the functions of a government. Another idea, that

the issue of paper-money ought to be wholly controlled by government, or ought to rest entirely upon government credit, places a high degree of faith in the trustworthiness of governments, and is held by many to misconceive the nature and objects of a paper currency. The tendency in England has been to regard the issue of notes not so much as allied to the commercial operation of drawing bills, but as analogous to the royal function of coinage. In Scotland, on the other hand, a perfectly sound currency was furnished by banks acting until 1845 on their own unrestricted discretion, and the prevailing tendency is still towards a maximum of freedom in the issue of representative paper-money. See also *Bank and Money*.

Currentom'eter, CURRENT GAUGE, an instrument for measuring the velocity of currents. It may be constructed in various ways, *e.g.* a simple tube which is bent and has its lower end open to the current, the ascension of water in the vertical part indicating the velocity of the current.

Currents, MARINE, masses of sea-water flowing or moving forward in the manner of a great stream. They are phenomena of the highest importance, both on account of their influence upon the climate of many maritime regions—an influence often reaching far inland—and their practical relation to the art of navigation. These currents are very numerous, and taken together constitute an oceanic circulation the intricacy and irregularity of whose form is owing to the number and variety of the agencies at work. Amongst the theories which have been put forward to account for the existence of currents the chief place belongs to the theory of a circuit maintained between equatorial and polar waters. According to this theory there is in either hemisphere an area within which the waters of the ocean are colder, and hence by many degrees denser, than within the belt of the tropics. The natural result is a tendency of the colder and heavier water to sink and to diffuse itself over the lower portion of the ocean-bed, and a movement of the warmer and lighter water in the direction of the surface, over which it tends to become diffused. In other words, the colder waters will move beneath the surface in the direction of the equator, and the warmer waters will flow along the surface in the direction of either pole. Hence, in either half of the globe two great and opposite currents—a

cold current flowing from the pole towards the equator, and a *warm* current flowing from the equator in the direction of the pole. This theory has been excellently illustrated by Dr. Carpenter's experiment, in which a trough of glass filled with water and having a lump of ice at one end and a heated bar of iron at the other exhibits a similar circulation of hot and cold currents. To this theory Sir C. Wyville Thomson opposed a theory of evaporation as the general cause of the movement, holding that in the Antarctic Ocean at least the return of moisture to the south to balance the cold indraught of water that comes from thence takes place in a large measure through the atmosphere. Another great general cause of currents is to be found in the axial rotation of the earth eastward, by which the movement of tropical waters towards the pole is deflected eastward, and becomes in the northern hemisphere a north eastwardly current and in the southern a south-eastwardly one. Under the operation of the same laws the opposite currents from polar latitudes to the equator are deflected in south-westerly and north-westerly directions respectively. It is to such influences that we may in the main attribute the well-known differences between the climates of North America and Europe within correspondent parallels. Other causes, more local in their nature, must be looked for to explain the origin and direction of currents in particular cases. In the case of surface or drift currents, for instance, it is probable that these are largely caused by the action of winds. Thus it is to the constant drift of surface water to the westward under the influence of the trade-wind that the equatorial currents of the Atlantic and Pacific are due. In the case of the Atlantic Ocean the westward-moving waters, encountering the eastward extension of the South American mainland, become of necessity divided into two streams, the one of which sets to the southward along the eastern coast of Brazil, while the other advances along the more northwardly portions of the South American continent, past the outlets of the Amazons and the Orinoco, and thence into the Caribbean Sea. From the latter land-inclosed basin its course is necessarily into the similarly shut-in basin of the Mexican Gulf, whence it finally emerges through the narrow channel of Florida as the well-known Gulf-stream (which see). In the case of the Pacific Ocean there exists no such unbroken

land barrier to the westwardly progress of the equatorial waters. A portion of its equatorial stream, however, is deflected to the northward towards the coasts of Japan (where it forms the well-known Japan stream, setting to the north-eastward, past the Kuriles, in the direction of the Aleutian Islands), while another portion turns southwardly in the direction of Australia and New Zealand. To the same action of the winds, operating in connection with the obstacles presented by the land, divergent and counter-currents are due. Thus in the Atlantic and the Pacific there flows between the two equatorial trade-wind currents a counter-current in exactly the opposite direction, and there is a similar counter-current in the Indian Ocean north of its sole trade-wind current. Currents called *indraught currents* are also caused by the flow of water to replace that taken away by currents due to causes already mentioned. An example of this is found on the west coast of Africa, where an indraught current replaces the water blown towards the coast of South America. In the case of inland seas evaporation determines the direction of the surface currents, the direction being inwards, where, as in the Mediterranean, the evaporation exceeds the inflow of fresh water; and outwards, as in the Baltic and the Black Sea, where there is an opposite state of matters.

Curric'ulum, originally, in Latin, the course over which the race was run, hence the whole course of study at a university necessary to qualify for a particular degree.

Currie, JAMES, M.D., the biographer of Burns and earliest editor of his works, was born in Dumfriesshire in 1756, died in 1805. He tried in succession commerce, journalism, and medicine, and in 1780, after completing his studies at Edinburgh, he was appointed assistant-surgeon in the army. Disappointed in his hopes of promotion he settled at Liverpool, where he was made a physician to the infirmary, and increased his reputation by some publications on medicine. Having made an excursion into Scotland in 1792 he had become personally acquainted with Robert Burns, and upon the death of the poet he was induced to become the editor of an edition of his works, to which he added a memoir. By this work a sum of £1400 was raised for Mrs. Burns and her family.

Curry, an Eastern condiment, a powder composed of cayenne-pepper, coriander, ginger, turmeric, and other strong spices.

Currying is the art of dressing cow-hides, calves'-skins, seal-skins, &c., principally for shoes, saddlery, or harness, after they have come from the tanner. In dressing leather for shoes the leather is first soaked in water until it is thoroughly wet; then the flesh side is shaved to a proper surface with a knife of peculiar construction, rectangular in form with two handles and a double edge. The leather is then thrown into the water again, scoured upon a stone till the white substance called *bloom* is forced out, then rubbed with a greasy substance and hung up to dry. When thoroughly dry it is *grained* with a toothed instrument on the flesh side and *bruised* on the grain or hair side for the purpose of softening the leather. A further process of *paring* and *graining* makes it ready for *waxing* or *colouring*, in which oil and lamp-black are used on the flesh side. It is then sized, dried, and tallowed. In the process the leather is made smooth, lustrous, supple, and water-proof.

Curse of Scotland, a term given to the nine of diamonds in a pack of cards, on account, it is supposed, of the pips having a resemblance to the heraldic bearings of the Earl of Stair, who was detested for his share in the massacre of Glencoe.

Curso'res, or **RUNNERS**, an order of birds, which includes the ostrich, rhea, emeu, cassowary, and apteryx. The birds of this order are distinguished by their remarkable velocity in running, the rudimentary character of their wings, which are too short to be of use for flight, and by the length and strength of their legs. The breast-bone is destitute of the ridge or keel which it possesses in most birds, hence the name *Ratitæ* (*L. ratis*, a raft).

Curtis, GEO. WM., author, was born in Providence, R. I., Feb. 24, 1824. In 1850 connected himself with the *New York Tribune*; in 1853 with *Harper's Monthly*. In 1857 he became the editor of *Harper's Weekly*, and of *Harper's Bazar* in 1867. He was an earnest advocate of civil-service reform. He died Aug. 31, 1892.

Curtius, ERNST, a German Hellenist, born 2d Sept. 1814; visited Athens and the Peloponnesus in 1837 to make antiquarian researches; returned to his native country in 1840; appointed tutor to Prince Frederick William; succeeded Hermann as professor at Göttingen in 1856. Of his works, which all relate to Greek antiquities, the best known is the *History of Greece*, which has been published in English.

Curtius, GEORG, brother of the preceding, a distinguished philologist, notable for his application of the comparative method to the study of the Greek and Latin languages. He was born at Lübeck in 1820, and in 1862 became professor of classical philology at Leipzig. He died in 1885. Of his works a Greek Grammar, Principles of Greek Etymology, and The Greek Verb, have been translated into English.

Curtius, METTUS or MARCUS, a noble Roman youth, who, according to the legend, plunged with horse and armour into a chasm which had opened in the forum (B.C. 362), thus devoting himself to death for the good of his country, a soothsayer having declared that the dangerous chasm would only close if what was most precious to Rome was thrown into it.

Curtius Rufus, QUINTUS, a Roman writer, author of a History of Alexander the Great, in ten books, the two first of which are lost. His style is florid, and his narratives have more of romance than of historical certainty. Nothing certain is known of his life.

Curule Magistrates, in ancient Rome, the highest dignitaries of the state, distinguished from all others by enjoying the privilege of sitting on ivory chairs (*sellæ curules*) when engaged in their public functions. The curule magistrates were the consuls, prætors, censors, and chief ædiles, who, to distinguish them from the plebeian ædiles, were called *curule*.

Curve (Latin, *curvus*, crooked), a line which may be cut by a straight line in more points than one; a line in which no three consecutive points lie in the same direction. The doctrine of curves and of the figures and solids generated from them constitutes what is called the higher geometry, and forms one of the most interesting and important branches of mathematical science. Curve lines are distinguished into algebraical or geometrical and transcendental or mechanical. The varieties of curves are innumerable; that is, they have different degrees of bending or curvature. The curves most generally referred to, besides the circle, are the ellipse, the parabola, and the hyperbola, to which may be added the cycloid.

Curwen, JOHN, English musician, the chief promoter of the tonic sol-fa method of teaching to sing, was born 14th Nov. 1816. He became a minister of the Independent Church, and became acquainted with Miss Glover's sol-fa system while visiting that lady's schools at Norwich. After that

he devoted much of his time to bringing the new method before the public by lectures, publications, and the establishment of a tonic sol-fa association and college. He died on 26th May, 1880.

Curzola, the most beautiful of the Dalmatian islands, in the Adriatic, stretching w. to e. about 25 miles, with an average breadth of 4 miles; area, 85 square miles. It is covered in many places with magnificent timber. The fisheries are very productive. It contains a town of the same name. Pop. 5437.

Cusco. See *Cuzco*.

Cusco-bark, CUZCO-BARK, the bark of *Cinchona pubescens*, which comes from Cuzco, in S. America, and is exported from Arequipa. It contains a peculiar alkaloid called cusco-cinchonine, or cusconine, which resembles cinchonine in its physical qualities, but differs from it in its chemical properties. When applied medicinally it excites warmth in the system, and is therefore recommended to be given in cold intermittents and low typhoid states of the system.

Cuscus, a genus of animals of the phalanger family, somewhat resembling the opossums, having a dense woolly fur, prehensile tails, and living on leaves; natives of the smaller Australian islands.

Cuscuta, a genus of plants, type of the Cuscutaceæ, or dodder order, consisting of leafless, parasitic, twining herbs, sometimes reckoned a sub-order of the Convolvulus order. Didders inhabit all the temperate and warmer regions of the globe.

Cushing, CALEB, statesman, was born in Salisbury, Mass., Jan. 17, 1800. He was admitted to the bar in 1823. As Commissioner to China made the first treaty with that country. In 1853 was appointed U. S. Attorney-General. In 1872 was counsel for the U. S. at Geneva in settlement of the Alabama claims. In 1874 was minister to Spain. His publications were versatile. He died Jan., 1879.

Cushman, CHARLOTTE S., actress, was born in Boston, July 23, 1816. She made her first appearance in opera in the Tremont Theatre. As an actress she first appeared as Lady Macbeth in 1835. She was powerful in tragedy, great in Shakespearian characters. As a dramatic reader she developed remarkable ability. Died 1876.

Cushion-capital, a capital which has the appearance of a cushion pressed upon by the weight of its entablature, or, like the Nor-

man capital, consisting of a cube rounded off at its lower extremities.

Cusp, the point at which two converging curves meet and have a common tangent. Such points are numerous in architecture in

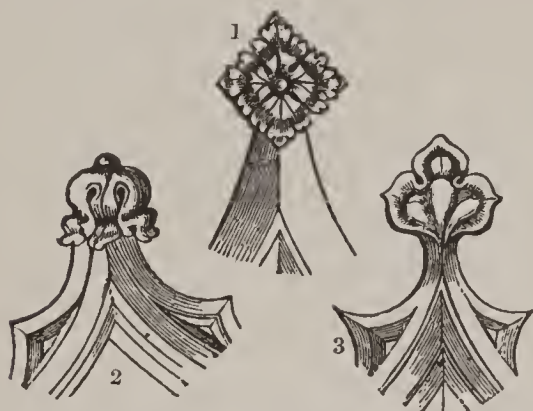

Architectural Cusps.—1, Henry VII.'s Chapel. 2, Monument of Sir James Douglas, Douglas Church. 3, Beauchamp Chapel, Warwick.

the internal curvings of trefoils, heads of Gothic windows, &c. In the Decorated and Perpendicular styles the cusps, in addition to leaves, flowers, &c., were frequently ornamented with heads or animals. In the Romanesque and Norman styles they were often ornamented with a small cylinder which bore a flower or similar ornament.

Cuspa'ria Bark, the bark of the *Galipea Cusparia*, and some other species. See *Angostura Bark*.

Cusso (*Hagenia abyssinica*), a small Abyssinian tree, order Rosaceæ, yielding flowers which are imported into Europe and used as an anthelmintic.

Cus'tard, a composition of milk or cream and eggs, sweetened with sugar and variously flavoured; cooked in the oven or stew-pan.

Custer, GEORGE A., soldier, was born in Harrison co., Ohio, Dec. 5, 1839. He graduated from West Point in 1861. He participated in all but one of the battles of the Army of the Potomac. After the civil war he performed arduous service on the frontier. In 1876 Gen. Custer, with his regiment, was met by overwhelming numbers of Indians and he and his entire command were slain.

Custo'dia, a shrine of precious metal in the shape of a cathedral, in which the host or the relics of a saint are carried in procession on certain solemn occasions.

Custom-house, an establishment where commodities are entered for importation or exportation and the duties, bounties, &c., on the same are payable.

Customs, duties charged upon goods exported from or imported into a state. Cus-

toms in the United Kingdom almost entirely consist of taxes or duties charged on the importation for consumption of foreign and colonial merchandise. About the end of the 16th century the revenue derived from customs was about £50,000; towards the end of the 17th, £781,987; in 1890-91, £19,753,907. The articles now subject to duty are comparatively few in number, and of these spirits, wine, and tobacco furnish two-thirds of the whole revenue from customs. In many other countries customs duties are levied on the great majority of articles of import, and largely for protective purposes. The revenue derived from this source in the United States was, for fiscal year 1892, \$177,452,064.

Custos Rotulo'rum, the chief civil officer or lord-lieutenant of an English county, who has the custody of the rolls and records of the sessions of the peace. He is usually a nobleman, and always a justice of the peace of the quorum in the county where he is appointed.

Cutch. See *Catechu*.

Cutch, a state in the west of India, lying to the south of Sind, under British protection; area, 6500 sq. miles. During the rainy season it is wholly insulated by water, the vast salt morass of the Rann separating it on the north and east from Sind and the Guicowar's Dominions. Its southern side is formed by the Gulf of Cutch, and on the west it has the Arabian Sea. The country is subject to violent volcanic action. The date is the only fruit which thrives, and the principal exports are cotton and horses. The Rann of Cutch covers about 9000 square miles, and is dry during the greater part of the year. Pop. of the state, 512,084.

Cutch'erry, in the East Indies, a court of justice or public office.

Cutch Gunda'va, a division of Beloochistan, in the north-east; area, 10,000 sq. miles; pop. 100,000.

Cuth'bert, St., celebrated father of the early English Church, was born, according to the tradition, near Melrose about 635. He became a monk, and in 664 was appointed prior of Melrose, which after some years he quitted to take a similar charge in the monastery of Lindisfarne. Still seeking a more ascetic life, Cuthbert then retired to the desolate isle of Farne. Here the fame of his holiness attracted many great visitors, and he was at last persuaded to accept the bishopric of Hexham, which

he, however, resigned two years after, again retiring to his hermitage in the island of Farne, where he died in 687. The anniversary of his death was a great festival in the English Church.

Cu'ticle, the epidermis or outermost layer of the skin, a thin, pellucid, insensible membrane that covers and defends the true skin.

Cu'tis, in anatomy, a dense resisting membrane, of a flexible and extensible nature, which forms the general envelope of the body; it is next below the cuticle, and is often called the true skin.

Cu'tlass, a short sword used by seamen. A guard over the hand is an advantage. It is, if well understood, a very effectual weapon in close contact: on account of its shortness it can be handled easily, and yet is long enough to protect a skilful swordsman.

Cu'tlery is a term applied to all cutting instruments made of steel. The finer articles, such as the best scissors, penknives, razors, and lancets are made of cast-steel. Table-knives, plane-irons, and chisels of a very superior kind are made of shear-steel, while common steel is wrought up into ordinary cutlery. One of the commonest articles of cutlery, a common razor, is made as follows:—The workman, being furnished with a bar of cast-steel, forges his blade from it. After being brought into true shape by filing, the blade is exposed to a cherry-red heat and instantly quenched in cold water. The blade is then tempered by first brightening one side and then heating it over a fire free from flame and smoke, until the bright surface acquires a straw colour (or it may be tempered differently). It is again quenched, and is then ready for being ground and polished.

Cuttack, a town of Hindustan, in Orissa, on the right bank of the Mahanuddy, 60 miles from its embouchure and 230 s.s.w. Calcutta. It has little trade, and is known mainly for its beautiful filagree work in gold and silver. Pop. 51,000. The district of Cuttack has an area of 3517 sq. miles. It is well watered, and rice, pulse, sugar, spices, dye-stuffs, &c., are grown along the coast, which is low and marshy, and wheat and maize in the hilly regions. On the coast salt is extensively manufactured. Pop. 1,738,165.

Cutter, a small vessel, furnished with one mast, and a straight running bowsprit which may be run in upon deck. It differs from the sloop in having no stay to support its jib.

Cuttle-bone, the dorsal plate of *Sepia officinālis*, formerly much used in medicine as an absorbent, but now used for polishing wood, painting, varnishing, &c., as also for pounce and tooth-powder.

Cuttle-fish. See *Cephalopoda*, *Squid*, and *Sepia*.

Cutty-stool, a low stool, the stool of repentance, a seat formerly set apart in Presbyterian churches in Scotland, on which offenders against chastity were exhibited before the congregation and submitted to the minister's rebukes before they were readmitted to church privileges.

Cut-water, the sharp part of the bow of a ship, so called because it cuts or divides the water.

Cut-worm, any worm or grub which is destructive to cultivated plants, as cabbage, corn, beans, &c.

Cuvier (küv-yā), GEORGES LÉOPOLD CHRÉTIEN FRÉDÉRIC DAGOBERT, BARON, a distinguished modern naturalist, was born, Aug. 23, 1769, at Montbéliard, then belonging to the duchy of Würtemberg. After studying at Stuttgart he became a private tutor in the family of Count D'Héricy, in Normandy, where he was at liberty to devote his leisure to natural science, and in particular to zoology. A natural classification of the Verines or worms was his first labour. The ability and knowledge shown in this work procured him the friendship of the greatest naturalists of France. He was invited to Paris, established at the Central School there, and received by the Institute as a member of the first class. His lectures on natural history, distinguished not less for the elegance of their style than for profound knowledge and elevated speculation, were attended by all the accomplished society of Paris. In Jan. 1800 he was appointed to the Collège de France. Under Napoleon, who fully recognized his merits, Cuvier held important offices in the department of public instruction. In 1819 he was received amongst the forty members of the French Academy. He died at Paris 13th May, 1832. Amongst the numerous works by which he greatly extended the study of natural history we may mention *Recherches sur les Ossements Fossiles*; *Discours sur les Révolutions de la Surface de la Globe*; *Leçons d'Anatomie Comparée*; *Histoire Naturelle des Poissons*; *Le Règne Animal*, a general view of the animal kingdom, in which all animals were divided into the four great classes; *Vertebrata*, *Mollusca*, *Arti-*

culata, and Radiata. His brother FRÉDÉRIC (1773–1838) was also a naturalist of no mean order.

Cux'haven, a German seaport, bathing-place, and pilot station in Hamburg territory, at the mouth of the river Elbe. The harbour is large and commodious, and there are shipyards, a lighthouse, an old castle, fortifications, &c. Pop. about 4500.

Cuyaba (kō-yā-bä'), or JESUS DE CUYABA, a town of Brazil, capital of Matto Grosso, on the river Cuyaba, nearly 300 miles above its entrance into Paraguay. Pop. 11,000 to 12,000. There are rich gold-mines in the district.

Cuyp (koip), ALBERT. See KUYP.

Cuzco, an ancient city in Peru, capital of a department of the same name, is situated in a wide valley about 11,300 feet above sea-level, between the Apurimac and Urubamba. The houses are built of stone, covered with red tiles, and are many of them of the era of the Incas. The ruins of the fortress built by the Incas, a stupendous specimen of cyclopean architecture, are still to be seen, as well as other massive specimens of ancient Peruvian architecture. The inhabitants manufacture sugar, soap, cotton, and woollen goods, &c. There is a university, a cathedral, &c. Cuzco is the most ancient of the Peruvian cities, and was at one time the capital of the empire of the Incas. In 1534 it was taken by Pizarro. Pop. 18,730. Area of the department, 95,547 sq. miles; pop. 238,445.

Cy'amus, a genus of Crustacea, the species of which are parasites on the whale. They are called *Whale-lice*.

Cyan'ic Series, in botany, a series of colours in flowers of which blue is the type, passing into red or white but never into yellow. It is distinguished from the *xanthic* series, of which the type is yellow, passing into red and white but never into blue.

Cy'anide, a combination of cyanogen with a metallic base.

Cy'anin, the blue colouring matter of certain flowers, as of the violet, corn-flower, &c. It is extracted from the petals by alcohol.

Cy'anite, or KYANITE, a mineral of the garnet family found both massive and in regular crystals. Its prevailing colour is blue but of varying shades. It is found only in primitive rocks.

Cyan'ogen, a compound radical composed of one atom of carbon and one of nitrogen; symbol Cy (or CN). It is a gas of a

strong and peculiar odour, resembling that of crushed peach leaves, and burning with a rich purple flame. It is unrespirable and highly poisonous. It unites with oxygen, hydrogen, and most non-metallic elements, and also with the metals, forming cyanides. Combined with hydrogen it forms prussic (hydrocyanic) acid. See *Prussic Acid*.

Cyanom'eter ('measurer of blue') is the name of an instrument invented by Saussure for ascertaining the intensity of colour in the sky. It consists of a circular piece of metal or pasteboard, with a band divided by radii into fifty-one portions, each of which is painted with a shade of blue, beginning with the deepest, not distinguishable from black, and decreasing gradually to the lightest, not distinguishable from white. The observer holds this up between himself and the sky, turning it gradually round till he find the tint of the instrument exactly corresponding to the tint of the sky.

Cyano'sis, the blue disease; the blue jaundice of the ancients. It is usually due to malformation of the heart, whereby the venous and arterial currents mingle.

Cyan'otype Process, a photographic picture obtained by the use of a cyanide. This process is in very common use by architects and engineers for copying plans, producing an image with white lines upon a blue ground. Sensitive paper is made by brushing it over with a solution of ferric oxalate (10 gr. to the oz.); it is then exposed under the positive and treated with a solution of potassium ferricyanide, by which the image is developed. The colour of the ground is deepened by subsequent washing with solution of potassium bisulphate.

Cyathe'a, a genus of arborescent ferns, order Polypodiaceæ, characterized by having the spores, which are borne on the back of the frond, inclosed in a cup-shaped indusium. There are many species scattered over the tropical regions of the world. *C. medullaris* is a fine New Zealand species of comparatively hardy character. The soft pulpy medullary substance in the centre of the trunk is an article of food, somewhat resembling sago.

Cybele (sib'e-lē), originally a goddess of the Phrygians, like Isis, the symbol of the moon, latterly introduced among the Greeks and Romans. Her worship was celebrated with a violent noise of instruments and rambling through fields and woods, and her priests were eunuchs in memory of Atys. (See *Atys*.) In later times she was repre-

sented as a matron, with a mural crown on her head, in reference to the improved condition of men arising from agriculture and their union into cities.

Cycada'ceæ, or CYCADS, a nat. order of gymnospermous plants, resembling palms in their general appearance, and, as a rule, increasing by a single terminal bud. The leaves are large and pinnate, and usually rolled up when in bud like a crozier. The microscopic structure of the wood as well as the general structure of their cones ally them with the conifers. The plants of this order inhabit India, Australia, Cape of Good Hope, and tropical America. Many are fossil.

Cy'cas, genus of plants, type of the Cycadaceæ.

Cyclades (sik'la-dēz), or KYKLADES, the principal group of islands in the Grecian Archipelago now belonging to the Kingdom of Greece, so named from lying round the sacred island of Delos in a circle (Gr. *cyclos* or *kuklos*). The largest islands of the group are Andros, Paros, Myconos, Tenos, Naxos, Melos, and Thera or Santorin. They are of volcanic formation and generally mountainous. Some are very fertile, producing wine, olive-oil, and silk; others almost sterile. The inhabitants are excellent sailors. Pop. 132,020.

Cy'clamen, a genus of bulbous plants, nat. order Primulaceæ or primroses. The



Cyclamen (garden variety).

species are low-growing herbaceous plants, with very handsome flowers. Several of them are favourite spring-flowering greenhouse plants. An autumnal-flowered species (*C. hederacefolium*) has become naturalized in parts of the south of England. The fleshy root-stalks, though acrid, are greedily

sought after by swine; hence the vulgar name, *Sowbread*.

Cycle (sī'kl; Gr. *cyclos* or *kuklos*, a circle) is used for every uniformly-returning succession of the same events. On such successions or cycles of years rests all chronology, particularly the calendar. Our common solar year, determined by the periodical return of the sun to the same point in the ecliptic, everybody knows contains fifty-two weeks and one day, and leap-year a day more. Consequently in different years the same day of the year cannot fall upon the same day of the week. And as every fourth year is a leap-year, it will take twenty-eight years (4×7) before the days return to their former order according to the Julian calendar. Such a period is called a *solar cycle*. The *cycle of the moon*, or golden number, or metonic cycle, is a period of nineteen years after which the new and full moons return on the same days of the month.

Cyclic Poets. See *Greece (Literature)*.

Cycling, the art of locomotion by means of a machine consisting of two, three, or sometimes four wheels connected by a light framework of steel and having a seat or seats for one or more riders. It is propelled by the pressure of the rider's feet on two cranks attached to an axle. To the practised cyclist his machine is a rapid and easy mode of travelling, and the rate of twenty miles an hour has been attained both by bicyclists and tricyclists. The most remarkable example of what can be done by a skilled cyclist is the journey of 12,000 miles performed by Mr. Thomas Stevens across the continents of America, Europe, and Asia on a bicycle. Commencing in April, 1884, he crossed first America, then Europe, then Asia, finishing at Yokohama in Japan in December of the same year. Of late some attempts have been made to make use of cycling in the military art. See *Bicycle* and *Tricycle*.

Cyclobranchiata (sī'klō-brang-ki-ā'ta), an order of gasteropods, in which the branchiæ or organs of respiration form a fringe around the body of the animal, between the edge of the body and the foot. The order consists principally of the limpets.

Cy'cloid (Gr. *cyclos*, circle), a curve generated by a point in the plane of a circle when the circle is rolled along a straight line and kept always in the same plane. The genesis of the common cycloid may be conceived by imagining a nail in the circumference of a carriage-wheel; the curves which the nail describes while the wheel runs forward are

cycloids. The cycloid is the curve of swiftest descent, that is, a heavy body descending by the force of its own gravity will move from one point of this curve to any other point in less time than it will take to move in any other curve which can be drawn between these points. Also, a body falls through any arc of an inverted cycloid in the same time whether the arc be great or small. In the figure let the circle of

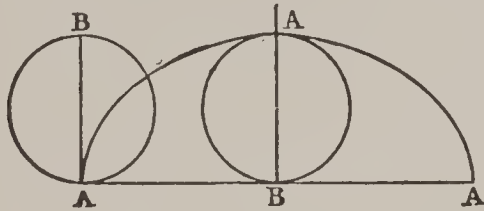

which the diameter is AB, make one revolution upon the straight line ABA, equal in length to its circumference, then the curved line AAA, traced out by that point of the circle which was in contact with the point A in the straight line when the circle began to revolve, is called a cycloid. The length of the cycloid is four times the diameter of the generating circle, and its area three times the area of this circle. This line is very important in the higher branches of mechanics.

Cycloid Fishes, an order of fishes according to the arrangement of Agassiz, having smooth, round, or oval scales, as the salmon and herring. The scales are formed of concentric layers, not covered with enamel and not spinous on the margins; they are generally imbricated, but are sometimes placed side by side without overlapping.

Cyclone (sī'klōn), a circular or rotatory storm or system of winds, varying from 50 to 500 miles in diameter, revolving round a centre, which advances at a rate that may be as high as 40 miles an hour, and towards which the winds tend. Cyclones of greatest violence occur within the tropics, and they revolve in opposite directions in the two hemispheres—in the southern with, and in the northern against, the hands of a watch—in consequence of which, and the progression of the centre, the strength of the storm in the northern hemisphere is greater on the south of the line of progression and smaller on the north, than it would be if the centre were stationary, the case being reversed in the southern hemisphere. An *anticyclone* is a storm of opposite character, the general tendency of the winds in it being away from the centre, while it also shifts within com-

paratively small limits. Cyclones are preceded by a singular calm and a great fall of the barometer.

Cyclopædia. See *Encyclopædia*.

Cyclo'pean Works, in ancient architecture, masonry constructed with huge blocks of stone unhewn and uncemented, found in Greece, Sicily, Asia Minor, &c. A similar style of work is to be found in the British isles, as the Rock of Cashel in Ireland or the Laws near Broughty-Ferry in Scotland.

Cy'clops (Gr. *Kyklōps*, literally round-eyed, pl. *Kyklōpes*; in English the word is used as a singular or a plural), in Greek myths, a fabled race of one-eyed giants, the sons of Urānus and Gē (Heaven and Earth), slain by Apollo. They were often represented as a numerous race living in Sicily and rearing cattle and sheep. Of such is the Cyclops of the Odyssey. Later traditions describe them as the servants of Vulcan working under Ætna, and engaged in forging armour and thunderbolts.—*Cyclops* is likewise the generic name of a certain minute Crustacean, order Branchiopoda, having but one eye, situated in the middle of its forehead.

Cyclos'tomi, CYCLOSTOM'ATA, an order of cartilaginous fishes having circular mouths, as the lamprey. Called also *Marsipobranchia*.

Cyder. See *Cider*.

Cydnus (sid'nus), a river in Cilicia, rising in the Taurus Mountains, anciently celebrated for the clearness and coolness of its waters.

Cydo'nia. See *Quince*.

Cygnus (sig'nus; 'the Swan'), one of Ptolemy's northern constellations. Within this constellation is one of the richest portions of the Milky Way.

Cyl'inder, a geometrical solid which, in popular language, may be described as a long round solid body, terminating in two flat circular surfaces which are equal and parallel. There is a distinction between *right* cylinders and *oblique* cylinders. In the first case, the axis, that is, the straight line joining the centre of the two opposite bases, must be perpendicular, and it may be regarded as described by the revolution of a rectangular parallelogram round one of its longer sides (the axis); in the second, the axis must form an angle with the inferior base.—In steam-engines, the cylinder is the chamber in which the force of the steam is exerted on the piston.

Cylin'drical Lens, a lens whose surfaces are cylindrical, instead of spherical which is

usually the case. A convex cylindrical lens brings the image of a source of light to a focus in a line instead of in a point. They are usually *plano-cylindrical*, that is, cylindrical on one side and flat on the other.

Cylin'drical Vaulting, in arch. the most ancient mode of vaulting, called also a wagon, barrel, or tunnel roof. It is a plain half-cylinder without either groins or ribs.

Cyllene (sil-lē'nē), a mountain of Southern Greece, 7789 feet high.

Cy'ma, in architecture, a wavy moulding the profile of which is made up of a curve of contrary flexure, either concave at top and convex at bottom or the reverse. In the first case it is called a *cyma recta*; in the second a *cyma reversa*.

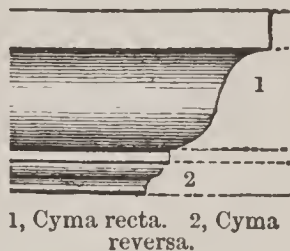

It is a member of the cornice, standing below the abacus or corona.

Cym'bals, musical instruments consisting of two hollow basins of brass, which emit a ringing sound when struck together. They are military instruments, but are now occasionally used in orchestras.

Cyme (sīn), in botany, a mode of inflorescence in which the principal axis terminates in a flower, and a number of secondary axes rise from the primary, each of these terminating in a flower, while from these secondary axes others may arise terminating in the same way, and soon, giving a flat-topped or rounded mass. Examples may be found in the common elder and the Caryophyllaceæ.



Cyme.

Cymri (kim'ri), a branch of the Celtic family of nations which appears to have succeeded the Gaels in the great migration of the Celts westwards, and to have driven the Gaelic branch to the west (into Ireland and the Isle of Man) and to the north (into the Highlands of Scotland), while they themselves occupied the southern parts of Britain. At a later period they were themselves driven out of the Lowlands of Britain by the invasions of the Angles, Saxons, and Jutes, and compelled to take refuge in the mountainous regions of Wales, Cornwall, and the north-west of England. Wales may now be regarded as the chief seat of the Cymri.

Cynanche (sin-ang'ke), a name given to several diseases of the throat or windpipe, such as quinsy, croup, &c.

Cyn'ara, a genus of *Compositæ*, in many respects like the thistle. The two best-known species are the artichoke and the cardoon.

Cynewulf (kin'e-wulf), an Anglo-Saxon or early English poet, whose name we only know from its being given in runes in the poems attributed to him, viz. *Elene* (Helena), the legend of the discovery of the true cross; *Juliana*, the story of the martyr of that name; and *Crist* (Christ), a long poem incomplete at the beginning. The name Cynewulf also occurs as the solution of one of the metrical riddles in the Anglo-Saxon collection. Other poems, the *Andreas*, the *Wanderer*, the *Sea-farer*, &c., have been ascribed to him without sufficient grounds. Cynewulf probably lived in the first half of the 8th century. From his poems we may gather that he spent the earlier part of his life as a wandering minstrel, devoting the later to the composition of the religious poems connected with his name.

Cynics (sin'iks), a sect of philosophers among the ancient Greeks, founded by Antisthenes, a scholar of Socrates, at Athens, about 380 B.C. Their philosophy was a one-sided development of the Socratic teaching by Antisthenes and his followers, who looked only to the severer aspect of their master's doctrines, and valued themselves on their contempt of arts, sciences, riches, and all the social civilization of life. They made virtue to consist in entire self-denial and independence of external circumstances. In time this attitude degenerated into a kind of philosophic savagery and neglect of decency, and the Cynics fell into contempt.

Cyn'ips, the gall-fly, a genus of hymenopterous insects remarkable for their extremely minute head and large, elevated thorax. The females are provided with an ovipositor by which they make holes where they deposit their eggs in different parts of plants, thus producing those excrescences which are known as galls. The gall of commerce used in manufacturing ink is caused by the *Cynips gallæ tinctoriæ* piercing a species of oak which grows in the Levant. The *Cynips rosæ*, or bedeguar gall-fly, produces the hairy excrescences seen on the rose-bush and the sweet-brier. See *Bedeguar*.

Cynoceph'alus, a genus of baboons. See *Baboon*.

Cynoglos'sum, hound's-tongue, a genus of plants, nat. order Boraginaceæ, consisting of herbs from the temperate zones. *C. officināle* and *C. montānum* are British plants. The former has a disagreeable smell like that from mice, and was at one time used as a remedy in scrofula. There are about fifty other species, all coarse plants.

Cynomor'rium, a genus of plants, nat. order Cynomoriaceæ. *C. coccinēum*, the *fungus melitensis* of the old herbalists, is a small plant which grows in Sicily, Malta, and Gozo, and was valued as an astringent and styptic in dysentery and hæmorrhage.

Cynosar'ges (-jēz), in ancient Athens, a gymnasium in which Antisthenes, the founder of the Cynics, taught.

Cynosceph'alæ (Greek, 'dogs' heads'), a range of hills in Thessaly, memorable for two battles fought there in ancient times. The first was B.C. 364, between the Thebans and Alexander of Pheræ, in which Pelopidas was slain; and the second B.C. 197, in which the last Philip of Macedon was defeated by the Roman consul Flamininus.

Cynosu'ra, CYN'OSURE (lit. 'dog's tail'), an old name of the constellation Ursa Minor or the Lesser Bear, containing the north star.

Cynosu'rus, a genus of grasses. See *Dog's-tail Grass*.

Cyn'thius, a surname of Apollo, from Mount Cynthus, island of Delos, on which he was born. For the same reason Diana, his sister, is called Cynthia.

Cypera'ceæ, the sedges, a natural order of monocotyledonous plants including fully 2000 known species. The members of this order are grassy or rush-like plants, generally growing in moist places on the margins of lakes and streams. Their stem is a cylindrical or triangular culm with or without knots; the leaves are sheathing. They are of little or no economical use, with the exception of *Cyp̄erus Papyrus*, which furnished the papyrus of Egypt.

Cyp'erus, a genus of plants, type of the order Cyperaceæ. They are herbs with compressed spikelets of many flowers, found in cold climates, and represented in the British flora by two very rare marsh plants which occur in the south of England—*C. longus*, the galingale, and *C. fuscus*. *C. esculentus*, the rush-nut, has tubers that are used for food in the south of Europe.

Cypræa. See *Cowry*.

Cyp'ress, a genus of coniferous trees. The *Cupressus sempervirens*, or common Euro-

pean cypress, is a dark-coloured evergreen with extremely small leaves, entirely covering the branches. It has a quadrangular, or, where the top branches diminish in



Cypress (*Cupressus sempervirens*, var. *fastigiata*).

length, pyramidal shape. Cypress-trees, though of a somewhat sombre and gloomy appearance, may be used with great effect in shrubberies and gardens. They are much valued also on account of their wood, which is hard, compact, and very durable, of a reddish colour and a pleasant smell. It was used at funerals and as an emblem of mourning by the ancients. Amongst other members of the genus are the Indian cypress (*C. glauca*); the *C. pendula*, a native of China and Japan; and the *C. thurifera*, or incense-bearing cypress, a native of Mexico; the evergreen American cypress or White Cedar (*C. thyoides*); &c. The *Taxodium distichum*, or deciduous cypress of the U. States and Mexico, is frequently called the Virginian cypress. Its timber is valuable, and under water is almost imperishable. In parts of the United States this cypress constitutes forests hundreds of miles in extent.

Cyp'rian, ST., a father of the African Church, born at Carthage about the beginning of the 3d century, was a teacher of rhetoric there. About 246 he was converted to Christianity, when he distributed his property among the poor, and began to live in the greatest abstinence. The church in Carthage soon chose him presbyter, and in 248 he was made bishop. During the persecutions under Decius and Valerian he had

twice to leave Carthage, but continued by his extensive correspondence to govern the African church. He was beheaded in 258, for having preached the gospel in his gardens at Carthage. Amongst his writings are eighty-one Epistolæ or official letters, besides several works on doctrine.

Cyprin'idæ, the carps, a family of soft-finned abdominal fishes, characterized by a small mouth, feeble jaws, gill-rays few in number; body covered with scales; and no dorsal adipose fin, such as is possessed by the silures and the salmon. The members are the least carnivorous of fishes. They include the carps, barbels, tenches, breams, loaches, &c. The type genus is *Cyprinus*.

Cyprinodon'tidæ, a family of malacopterygious fishes, allied to the Cyprinidæ, or carps.

Cypri'nus, the carp genus of fishes, type of the family Cyprinidæ (which see).

Cypripe'dium, lady's slipper, a genus of plants of the nat. order Orchidaceæ. Only one species (*C. calceolus*) is a native of Britain. Three species are natives of the United States. *C. arietinum*, the Ram's-head, is found from Canada to Vermont.

Cyp'ris, a genus of minute fresh-water crustaceans popularly known as water-fleas. They have the body inclosed in a delicate shell and swim by means of cilia. The Cypris is common in stagnant pools, and is very often found in a fossil state.

Cy'prus, an island lying on the south of Asia Minor, and the most easterly in the Mediterranean. Its greatest length is 145 miles, maximum breadth about 60 miles; area, 3678 square miles. The chief features of its surface are two mountain ranges, both stretching east and west, the one running close to the northern shore, and extending through the long north-eastern horn or prolongation of the island, the other and more massive (Mt. Olympus) occupying a great part of the south of the island, and rising in Troödos to 6590 feet. Between them is the bare and mostly uncultivated plain called Messaria. There is a deficiency of water. The climate is in general healthy. The mountains are covered with forests of excellent timber (now under government supervision), and the island is esteemed one of the richest and most fertile in the Levant. Agriculture, however, is in a very backward state, and locusts sometimes cause great damage. Wheat, barley, cotton, tobacco, olives, raisins, and carobs are the most important vegetable products. The wine is famous, espe-

cially that known as *commandery*. Silkworms are reared, and a coarse kind of silk is woven. Salt in large quantities is produced. The minerals are valuable; the copper-mines were of great importance in ancient times (the name *copper* is derived from that of this island), and are again being worked. Large numbers of sheep and goats are reared on the extensive pasture lands of the island. The principal towns are Lefkosia or Nicosia, the capital, the only considerable inland town, and the seaports Larnaca and Limassol. The chief exports are carobs, wine, and cotton, with cheese, raisins, cocoons, wool, &c.

After belonging successively to the Phœnicians, Greeks, Egypt, Persia, and again Egypt, Cyprus in 57 B.C. became a Roman province, and passed as such to the eastern division of the empire. In 1191 it was bestowed by Richard of England (who had conquered it when engaged in the third crusade) on Guy de Lusignan, and after his line was extinct it fell into the hands of the Venetians (1489), with whom it remained till it was conquered by the Turks in 1571 and annexed to the Ottoman Empire. In 1878 it was ceded to Britain by the convention of Constantinople concluded between England and Turkey, its reversion to Turkey being provided if Russia should give up Batoum and Kars. Britain was also bound to pay a subsidy to Turkey annually amounting to about £93,000, but this is not paid directly, being retained as an offset against British claims on Turkey. The island has become much more prosperous under British administration, and roads, harbour-works, &c., have been constructed, trees planted, and schools opened. The head of the government is the chief-commissioner, and there is a legislative council of twelve elected and six official members, nine of the former being Greeks, the others Moham-medans. Pop. 1891, 209,286, of whom three-fourths belong to the Greek Church.

Cyp'selus, a genus of birds, type of the family Cypselidæ, including the swifts and their congeners. One peculiarity in this family is that the hind toe is turned forward along with the three anterior toes.

Cyr (sēr), St., a French village in the department of the Seine-and-Oise, 1 league west of Versailles; famous for the seminary for the education of ladies of rank which Louis XIV. founded here. During the revolution this institution was done away with, and the buildings finally converted into a mili-

tary school by Napoleon (1803). Pop. of the commune, 2870.

Cyrenaica (si-re-nā'i-ka), once a powerful Greek state in the north of Africa (corresponding partly with the modern Barca), west of Egypt, comprising five cities (Pentapolis), among which was Cyrene, a Spartan colony founded in 631 B.C. Latterly it came into the hands of the Ptolemies, and in B.C. 95 the Romans obtained it. The Arab invasion ruined it (647). Cyrenaica is at present a vast but as yet very imperfectly explored field of antiquities.

Cyrenaics (si-re-nā'iks), a philosophical sect founded about 380 B.C. by Aristippus, a native of Cyrene and a pupil of Socrates. See *Aristippus*.

Cyrene (si-rē'nē), in ancient times a celebrated city in Africa, about 10 miles from the north coast, founded by Battus and a body of Dorian colonists, B.C. 631. Numerous interesting remains have been discovered here. The town now occupying the site of the ancient Cyrene is a miserable place in the vilayet of Barca. See *Cyrenaica*.

Cyr'il, the name of three saints or fathers of the Christian church. 1. **CYRIL OF JERUSALEM**, born there about the year 315 A.D., was ordained presbyter in 345, and in 350 or 351 became Patriarch of Jerusalem. He engaged in a warm controversy with Acacius, the Arian bishop of Cæsarea, by whose artifices he was more than once deposed from his episcopal dignity. He died in 386 or 388. We have some writings composed by him.

2. **CYRIL OF ALEXANDRIA** was educated by his uncle Theophilus, patriarch of Alexandria, and in 412 A.D. succeeded him as Patriarch. In this position his ambitious spirit brought the Christians into violent quarrels. At the head of the populace he assailed the Jews, destroyed their houses and their furniture, and drove them out of the city. Orestes, the prefect, having complained of such violence, was attacked by 500 furious monks. The assassination of Hypatia, the learned lecturer on geometry and philosophy, took place, it is said, at his instigation. His quarrel with Nestorius, and with John, patriarch of Antioch, regarding the twofold nature of Christ, convulsed the church, and much blood was shed between the rival factions at the Council of Ephesus in 431, the emperor having at last to send troops to disperse them. Cyril closed his restless career in 444.

3. **ST. CYRIL**, 'the Apostle of the Slaves,'

a native of Thessalonica. He converted the Chazars, a people of Hunnish stock, and the Bulgarians, about A.D. 860. He died about 868. He was the inventor of the Cyrillian Letters, which took their name from him, and is probably the author of the Apologies which bear his name.

Cyrillian Letters, characters used in one of the modes of writing the Slavonic language. In Poland, Bohemia, and Lusatia, Roman or German letters are used; but amongst Russians, Bulgars, and all the Slavonic nations belonging to the Greek Church, the Cyrillic alphabet, a modification of the Greek one, is in use. Besides these there is the Glagolitic alphabet, in which the oldest literature of the Slavonic church is written. See *Glagolitic*.

Cy'rus, King of Persia, a celebrated conqueror. The only ancient original authorities for the facts of his life are Herodotus and Ctesias. According to Herodotus he was the son of Cambyses, a distinguished Persian, and of Mandane, daughter of the Median King Astyages. His grandfather, made apprehensive by a prophecy that his grandson was to dethrone him, gave orders that Cyrus should be destroyed after his birth. But the boy was preserved by the kindness of a herdsman, and at length sent to his parents in Persia. Here Cyrus soon gathered a formidable army, conquered his grandfather (B.C. 559), and thus became king of Media and Persia. In 546 he conquered Cræsus of Lydia, and two years later took Babylon. He also subdued Phœnicia and Palestine, and restored the Jews from their Babylonish captivity. He was slain in battle with a Scythian nation in B.C. 529. Such is the account given by Herodotus; but the narrative of Ctesias differs in not making Cyrus a relative of Astyages and in some other points. The *Cyropædia* of Xenophon, which professes to give an account of the early life of Cyrus, is merely a philosophical romance.

Cyrus, called the *Younger*, to distinguish him from Cyrus the founder of the Medo-Persian monarchy, was the second son of Darius Nothus or Ochus. Having formed a conspiracy against his elder brother, Artaxerxes Mnemon, Cyrus was condemned to death, but released at the request of his mother, Parysatis, and made governor of Asia Minor. Here he secretly gathered an army, an important part of which consisted in 13,000 Greek auxiliaries, and marched eastwards. His brother with a large army

met him in the plains of Cunaxa (B.C. 401), and in the battle which followed, although the troops of Cyrus were victorious, Cyrus himself was slain. The retreat of Greek auxiliaries of Cyrus from the interior of Persia to the coast of Asia Minor is the subject of Xenophon's Anabasis.

Cysticer'cus, an immature form of tapeworm found in certain animals.

Cystic Worm, an immature or half-developed form of tapeworm, once erroneously supposed to be a distinct species of intestinal worm.

Cystid'eæ, a family of fossil echinoderms, with feebly-developed arms, occurring in the Silurian and Carboniferous strata.

Cysti'tis, inflammation of the bladder.

Cystop'teris, bladder-fern, a genus of polypodiaceous delicate flaccid ferns. Two are natives of Britain, *C. fragilis* (the brittle fern), common, and *C. montana*, very rare.

Cystot'omy, in surgery, the operation of cutting into the bladder for the extraction of a calculus.

Cythe'ra. See *Cerigo*.

Cyt'isin, an alkaloid detected in the ripe seeds of the Laburnum. It is of a nauseous taste, emetic and poisonous.

Cyt'isus, a genus of plants belonging to the natural order Leguminosæ, sub-order Papilionaceæ. The members of the genus are shrubs or small trees, sometimes spiny, with leaves composed of three leaflets, and with yellow, purple, or white flowers. They belong to Europe, Asia, and North Africa, and are very ornamental plants. The best-known species is the common laburnum (*C. Laburnum*; see *Laburnum*). Another species is the Alpine laburnum (*C. alpīnus*). The common broom (*C. Scoparius*) also belongs to this genus. See *Broom*.



Broom (*Cytisus Scoparius*).

Cyz'icus, a peninsula of Asia Minor, 60 miles south-west of Constantinople. It was once an island, and the site of an ancient town of the same name.

Czar (zär or tsär), a title of the Autocrat of all the Russias, not improbably a corruption of the Roman title Cæsar. It was first adopted in 1579 by Ivan II. The feminine

of czar is *czarina*, meaning the Empress of Russia.

Czarev'na, the wife of the czarowitz.

Czarowitz or **Czarevitch** (zä'ro-vits, zä're-vich), the title of the eldest son of the Czar of Russia.

Czartoryski (chär-to-ris'kē), **ADAM GEORGE**, prince, a celebrated Polish statesman and patriot, born 14th January 1770. His education was completed at the University of Edinburgh and in London. He fought bravely under Kosciusko, and after the partition of his country in 1795 was sent to St. Petersburg, where he formed a close friendship with Prince Alexander, and was made minister of foreign affairs. In 1805 he resigned his office, and withdrew soon after from public affairs. On the outbreak of the Polish revolution in 1830 he took an active part and became the head of the national government. After the failure he lived at Paris. He died July 16, 1861.

Czaslau (chäs'lou), a town, Bohemia, 45 miles E.S.E. of Prague. Here Frederick the Great defeated the Austrians (1742). Pop. 6178.

Czechs (chehs), the most westerly branch of the great Slavonic family of races. The Czechs have their head-quarters in Bohemia, where they arrived in the 5th century. (See *Bohemia*.) The origin of the name is unknown. The total number of the Czechs (including Moravians, Slovaks, &c.) is about 6,000,000, nearly all of whom live in the Austrian Empire. The Czechs proper, in Bohemia, number about 2,700,000. They speak a Slavonic dialect of great antiquity and of high scientific cultivation. The Czech language is distinguished as highly inflectional, with great facility for forming derivatives, frequentatives, inceptives, and diminutives of all kinds. Like the Greek it has a dual number, and its manifold declensions, tenses, and participial formations, with their subtle shades of distinction, give the language a complex grammatical structure. The alphabet consists of forty-two letters, expressing a great variety of sounds. In musical value the Czech comes next to Italian.

Czegled (tseg'lād), a market town, Hungary, 39 miles S.E. of Budapest, in a district yielding grain and wine. Pop. 24,872.

Czenstochowa (chen-sto-hō'vā), a town in Russian Poland, government of Petrokow. There is here a convent containing a famous picture of the Virgin, which is visited by vast numbers of pilgrims. Pop. 15,522.

Czernowitz (cher-nō'vits), a city of Austria, chief town of Bukowina, 138 miles s.e. of Lemberg. It has manufactures of clocks, silver-plate, carriages, toys, &c. Pop. (including suburbs), 57,403, a considerable proportion being Jews.

Czerny (cher'ni), GEORGE, hospodar of Servia, born in the neighbourhood of Belgrade about 1770; beheaded by the Turks, July 1817. His true name was George Petrovitch, but he was called *Czerny* or *Kara George*, i.e. Black George. In 1801

he organized an insurrection of his countrymen against the Turks, took Belgrade, and forced the Porte to recognize him as hospodar of Servia. In 1813, however, he had to retire before a superior force, and took refuge in Austria. Returning to his country in 1817 he was taken and put to death.

Czerny (cher'ni), KARL, pianist and musical composer, born 1791, died 1857. Among his pupils were Liszt, Thalberg, and other distinguished musicians.

Czirknitz. See *Zirknitz*.

D.

D, the fourth letter in our alphabet, representing a dental sound formed by placing the tip of the tongue against the root of the upper teeth, and then forcing up vocalized breath, or voice, into the mouth, the soft palate being raised to prevent its escape through the nose. **T** is formed in the same way, except that it is uttered with breath merely and not with voice. As a numeral **D** represents 500.

Dab (*Pleuronectes limanda*), a fish belonging to the family of the Pleuronectidæ, or



Dab (*Pleuronectes limanda*).

flat-fishes, comprising also the soles, turbot, halibuts, plaice, and flounder, the last two being included in the same genus with the dab. It is of a pale-brownish colour spotted with white on the side which it usually keeps uppermost, and white on the underside, and has rougher scales than the other members of the same genus. It is preferred to the flounder for the table.

Dab'chick. See *Grebe*.

Da Capo (Italian, 'from the head or beginning'), in music, an expression written at the end of a movement to acquaint the performer that he is to return to the beginning, and end where the word *fine* is placed.

Dacca, a commissioner's division of Hindustan in Bengal, at the head of the Bay of Bengal; area, 15,000 sq. miles. It is one of

the richest districts in India, and produces such quantities of rice as to be called the granary of Bengal. The surface is an uninterrupted flat, and is intersected by the Ganges and Brahmapootra—from whose periodical inundations its extraordinary fertility arises. Dacca was at one time celebrated for its hand-woven muslins, which are still hardly to be equalled in their combination of durability and delicacy; but this branch of industry has considerably decayed. Pop. 8,700,939, Mohammedans being in a decided majority. **Dacca**, its capital, is about 150 miles north-east of Calcutta. The city has much decayed with the decay of its staple trade in the celebrated Dacca muslin; suburbs which once extended northwards for 15 miles are now buried in dense jungle. Dacca, being free from violent heats, is one of the healthiest and pleasantest stations in Bengal. Pop. 79,076.

Dace (*Leuciscus vulgaris*), a small river fish of the family Cyprinidæ, and resembling the roach but longer and thinner. It is a gregarious fish swimming in shoals and in-



Dace (*Leuciscus vulgaris*).

habiting chiefly deep clear streams with a gentle current. It seldom exceeds a pound in weight.

Dace'lo, an Australian genus of kingfishers, one species of which is the 'laughing jackass,' so called on account of its harsh discordant note.

Dachshund (daks'hunt). See *Badger Dog*.

Da'cia, in ancient times, a region north of the Danube, inhabited by the Daci or Getæ, afterwards a Roman province. It was conquered by the emperor Trajan in 101 A.D., but in 274 A.D., in the reign of Aurelian, had to be abandoned by the Roman colonists.

Dacier (dä-syā), ANDRÉ, a learned Frenchman, born 1651. He studied at Saumur, and in 1672 he went to Paris, where the Duke of Montausier intrusted him with the editing of the Latin writer Pompeius Festus *ad usum Delphini* (see *Delphin Classics*). In 1683 he married Anne Lefèvre, the daughter of his former teacher, afterwards became perpetual secretary of the French Academy, published many editions and translations of the ancient classics, and died in 1722.—His wife, ANNE, born in 1651, published an edition of Callimachus, and was intrusted with several editions of the classics *ad usum Delphini*. Her learned works were not interrupted by her marriage in 1683. Her translation of Homer and writings on Homeric poetry attracted a good deal of attention. Amongst her other works were translations of Terence, Plautus, two plays of Aristophanes, Anacreon, and Sappho. She died in 1720.

Dacoity, originally, in the criminal code of India, a robbery committed by an armed band or gang, and technically under the present law of India any robbery in which five or more persons take a part. The term has also been applied more widely.

Dacryd'ium, a genus of trees of the pine or yew family. See *Huon Pine*, *Rimu*.

Dacryo'ma, a disease of the lachrymal duct of the eye, by which the tears are prevented from passing into the nose and consequently trickle over the cheek.

Dac'tyl, in versification, a foot consisting of one long followed by two short syllables, or, in English, one accented and two unaccented, as *happily*.

Dactylol'ogy is the art of expressing one's thoughts with the fingers.

Dactylorhiza (dak-ti-lō-rī'za). See *Fingers-and-Toes*.

Daddy-long-legs, a name given to a

species of the crane-fly (*Tipūla olerācēa*). See *Crane-fly*.

Da'do, in classical architecture, the middle part of a pedestal, that is to say, the solid rectangular part between the plinth and the cornice; also called the *die*. In the interior of houses it is applied to a skirting of wood several feet high round the lower part of the walls, or an imitation of this by paper or painting.

Dæ'dalus, a mythical Greek sculptor, the scene of most of whose labours is placed in Crete. He is said to have lived three generations before the Trojan war. He built the famous labyrinth in Crete, and invented wings for flight, which his son Icarus, foolishly attempting to use, was drowned in the Icarian Sea.

Daff'odil, the popular name of a European plant which is one of the earliest ornaments of our gardens, being favorite objects of cultivation. *Narcissus*

pseudo-narcissus, order *Amarylhidaceæ*. Many varieties of the daffodil are in cultivation, differing chiefly in bulk and in the form of the flower, which is of a bright primrose-yellow colour. There are other forms of the name in local or partial use.

Dagger, a weapon resembling a short sword, with sharp-pointed blade. In single combat it was wielded in the left hand and used to parry the adversary's blow, and also to despatch him when vanquished.

Daghestan', a province of Russia, in the Caucasus, stretching along the west side of the Caspian Sea; area, 11,036 square miles. Its fertile and tolerably cultivated valleys produce good crops of grain, and also silk, cotton, flax, tobacco, &c. The inhabitants, almost all professed Mohammedans, consist chiefly of races of Tartar origin and of Circassians. Capital Derbend. Pop. 592,533.

Dago, an island belonging to Russia, to the s.w. of the entrance of the Gulf of Finland, with productive fisheries. The inhabitants, almost all Swedes, are about 10,000.

Da'goba, in Buddhist countries and those which at one time held the Buddhist faith,

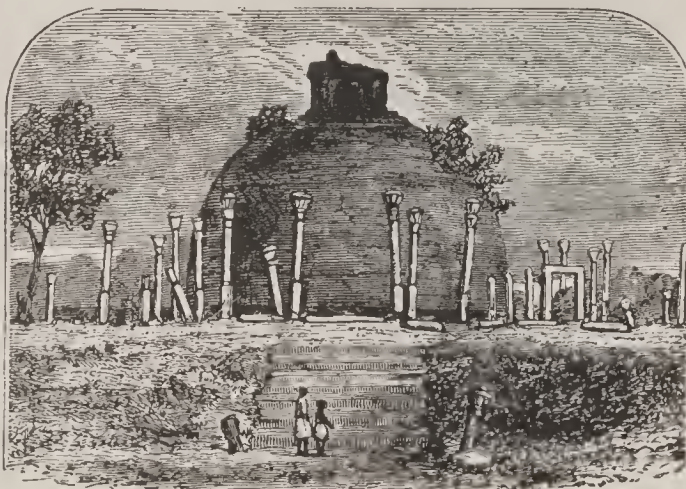

Ceylonese Dagoba.

a solid structure erected to contain some sacred relic or relics, as distinguished from the term *stupa* or *tope*, which in its specific application is usually restricted to monuments which commemorate some event or mark some spot sacred to the followers of Buddha. Dagobas are built of brick or stone, are circular in form, generally with a dome-shaped top, and are erected on natural or artificial mounds, while the stone or brick structure itself sometimes rises to an immense height. These dagobas have always been held in the highest veneration by the Buddhists, and a common mode of testifying their veneration is to walk round them, repeating prayers the while.

Dag'obert I. (called the *Great* on account of his military successes), King of the Franks, in 628 succeeded his father, Clothaire II. After a successful, magnificent, but licentious reign, he died at Epinay in 638.

Da'gon (probably from the Hebrew *dag*, a fish), the god of the Philistines, whose image is generally believed to have been in the form of a triton or merman, with the upper part human and the extremities, from the waist downwards, in the shape of the tail of a fish.

Daguerre (dä-gär), LOUIS JACQUES MANDÉ, was born in 1789 at Corneilles, dep. Seine-et-Oise. He was a scene-painter at Paris, and as early as 1814 had his attention directed by Nicéphore Niepce to the subject of photographic pictures on metal. In 1829 they made a formal agreement to work out the invention together, but it was not till after Niepce's death, on July 5, 1833, that Daguerre succeeded in perfecting the process since called *daguerreotype*. (See article following.) The new process excited the greatest interest. Daguerre was made an officer of the Legion of Honour, and an annuity of 6000 francs was settled on him, and one of 4000 on the son of Niepce. Daguerre died July 10, 1851.

Daguerreotype Process (da-ger'ro-tip), the original photographic process, consisting in sensitizing a silver plate with the vapour of iodine, and then placing it in a camera obscura previously focussed, and afterwards developing the picture by vapour of mercury. It is then fixed by immersion in hyposulphate of sodium. After thorough washing and drying the picture is covered with glass to prevent its being rubbed off. Daguerreotype has now been superseded by the collodion and other processes.

D'Aguesseau. See *Aguesseau*.

Dahabieh (dä-hä-bē'e), a boat used on the Nile for conveyance of travellers. It varies considerably in size; has one or two masts,



Dahabieh.

with a very long slanting yard on each mast supporting a triangular sail, and accommodates from two to eight passengers.

Dahlgren (däl'gren) **Guns**, an improved kind of cannon invented by John A. Dahlgren, admiral of the United States navy, born 1809, died 1870. Their chief peculiarity consists in their having less metal between the muzzle and the trunnions than ordinary cannons.

Dah'lia (so called after the Swedish botanist Dahl), a genus of plants belonging to the nat. order Compositæ, sub-order Corymbiferae, natives of Mexico. By cultivation an immense number of varieties have been produced, all deriving their origin from *D. coccinea* and *D. variabilis*. The flowers are large and beautiful, sporting into innumerable varieties. It does not stand frost, and has to be taken up during winter.

Dahlmann (däl'män), FRIEDRICH CHRISTOPH, a distinguished historian of Germany, born 1785, died 1860. He was professor at Göttingen and afterwards at Bonn, and distinguished himself as an advocate of liberal measures in politics. Amongst his principal works is a history of the English Revolution.

Daho'mey, a kingdom of West Africa, the extent of which has been variously estimated. According to Captain Burton its northern frontier is the river Tevi, about 100 miles from the coast; on the north-east and the north-west are the tribes of Yariba

and Aja, all of which are practically independent. The area is perhaps about 4000 miles. The soil is fertile, but agriculture is despised. The king is an absolute ruler, and human sacrifices form a main part of the state ceremonies. The regular army is made up partly of Amazons, who are compelled to celibacy, and make very effective soldiers. The capital is Abomey or Agbomey, where the king resides. In October 1884 a protectorate was proclaimed by Portugal over the kingdom of Dahomey and the seaport of Whydah annexed.

Daily News, a prominent London daily paper of Liberal politics, established in 1846. Its first editor was Charles Dickens. Of late it has been recognized as the leading organ of the Gladstonian Liberals.

Daily Telegraph, a London morning paper founded in 1855. It is of Independent Liberal politics, and has an immense circulation. It has a great reputation for the promptitude, fulness, and variety of its telegraphic advices, as well as for the freshness and novelty of its social articles.

Daimiel (dī-nē-el'), a town, Spain, New Castile, province of Ciudad Real, and 20 miles E.N.E. of the town of Ciudad Real, on left bank of the Azuer. The manufactures are linen and woollen fabrics, &c. Pop. 9652.

Daimios (dī'mi-ōz), a class of feudal lords formerly existing in Japan, but now deprived of their privileges and jurisdiction. By decree of August 1871 the daimios were made official governors on a salary for the state in the districts which they had previously held as feudal rulers.

Dair-el-kamar, the chief town of the Druses, Syria, on a slope of Mount Lebanon, 12 miles south-east of Beyrout, with about 30,000 inhabitants.

Dairi (dī'rē), or **DAIRI-SOMA**, an alternative name for the Mikado of Japan. See *Mikado*.

Dairy, the department of a farm which is concerned with the production of milk and its manufacture into butter and cheese. As a rule the soil and climate of a country, and the nearness of suitable markets, determine in a great measure the choice between tillage and dairy husbandry. For milk dairies cows that yield abundantly are selected, while for butter and cheese dairies the rich quality of the milk is the principal point. Regularity in feeding is very important, and the nature of the food given has a great effect on the quality of the milk. The

younger the cow is the richer is her milk, and the second and third years, therefore, are generally the most profitable, both quantity and quality being taken into account. In general, after the seventh or eighth year it is not considered advisable to continue the cow longer in milk, as her milk is fast deteriorating and she consumes more food than a young one. In the U. States the cattle of Ayrshire and Jersey hold the first place for dairy purposes, the first on account of the large yield which they give on comparatively poor feeding, the second for the richness of their milk. In the management of a dairy cleanliness is of the utmost importance, as no substance more easily receives and retains the odours and taste of putrescent matter than milk. No food, either vegetable or animal, should be allowed to enter the milk-house. A good mode of purifying the atmosphere of a milk-house is to dip cloths in a solution of chloride of lime and then hang them up on cords stretching from one corner to the other. In a similar way, too, the temperature of the room may be kept low during hot weather. The milk-room, therefore, should be built in such a manner as to be most easily cleaned and kept clean. The floor should be of smooth flagstones carefully jointed and dressed. It should have a slight slope towards the wall, where a channel is formed to convey all water and spilt liquid to a drain. All cornices and mouldings, or any projections or cavities where dust or dirt can lodge, should be as far as possible avoided. The practice of making a larder of a portion of the milk-house, or of having a number of cheeses drying on the shelves, is much to be reprehended. Spilt milk should never be allowed to remain an instant longer than is necessary for its removal. The liberal use of water (cold in summer and warm in winter) is always to be commended; a little common washing-soda dissolved in the water will be found useful in destroying any taint of sourness the milk-dishes may have acquired. The best dishes for milk are made either of glass, tin, tinned-iron, or well-glazed earthenware. Wood is objectionable because it is difficult to keep the dishes clean, and lead and zinc are liable to corrosion or decomposition from the acid of the milk. See also *Butter*, *Cheese*.

Dais, a platform or raised floor at the upper end of an ancient dining-hall, where the high table stood; also a seat with a high wainscot back, and sometimes with a canopy,

for those who sat at the high table. The word is also sometimes applied to the high table itself.

Daisy, the name of a plant which is very familiar, and a great favorite (*Bellis perennis*). It never ceases to flower, and is nearly naturalized in New England. In the days of chivalry it was the emblem of fidelity in love. Its name is literally day's eye, because it opens and closes its flower with the daylight.

Dâk, **DAWK**, in the East Indies, the post; a relay of men, as for carrying letters, despatches, &c., or travellers in palanquins. The route is divided into stages, and each bearer, or set of bearers, serves only for a single stage. A *dâk-bungalow* is a house at the end of a stage designed for those who journey by palanquin.

Daker-hen, a name sometimes given to the corn-crake or landrail, a bird of the family Rallidæ. See *Crake*.

Dakoity. See *Dacoity*.

Dakota, North and South, two of the States of the American Union, admitted in 1890, and lying between Minnesota, Nebraska, Montana, and Canada; lat. 43° to 49° N.; long. 97° to 104° W.; area about 149,100 sq. miles. The Missouri divides them into two nearly equal portions and partly forms the boundary between them and Nebraska; the Red River of the North forms a great part of the eastern boundary. Tributaries of the Missouri are the Little Missouri, Grand River, Big Cheyenne, White River, &c. The Black Hills are the chief elevations, some of their summits being about 7000 ft. high, rising from a general elevation of 3000 ft. The surface mainly consists of open grassy plains and rolling prairies or table-lands, with numerous lakes and ponds, and also large streams. The lakes are generally small, and for the most part fresh, but one in the north, called Minne Wakan or Devil Lake, about 40 miles long by 12 broad, and with no known outlet, is salt. The climate in the south is mild, and in the north severe, yet not so much so as we should expect from the degree of latitude. Much valuable timber exists, and wheat of a fine quality is extensively cultivated. In the south and west are barren tracts known as the Bad Lands. Coal, gold, silver, and other minerals abound. Pop. in 1890: North Dakota, 182,719; South Dakota, 328,808. Bismarck is the capital of North, and Pierre of South, Dakota. The two States have 4536 miles

of railway. There is an efficient school system. Emigration has been and continues to be large. The gold and silver-mining industries are remunerative.

Dakota Indians. See *Sioux*.

Dalai Lama. See *Lamaism*.

Dalbeattie (dal-bē'ti), a town in Kirkcudbrightshire, Scotland, with large granite-polishing works, paper-mills, concrete works, &c., and in the neighbourhood granite quarries. Pop. 4140.

Dalber'gia, a genus of fine tropical forest trees and climbing shrubs, nat. order Leguminosæ, some species of which yield excellent timber. *D. latifolia* (the black-wood, or East Indian rosewood) is a magnificent tree, furnishing one of the most valuable furniture woods. *D. Sissoo* gives a hard durable wood, called sissoo, much employed in India for railway-sleepers, house and ship building, &c.

Dalecar'lia, or **DALARNE**, a tract in Sweden. The name, meaning 'valley-land,' is kept alive in the minds of the inhabitants by the noble struggles which the Dalecarlians, its inhabitants, made to establish and maintain the independence of the country.

Dalgar'no, **GEORGE**, born at Aberdeen about 1627, took up his residence at Oxford, where he taught a private grammar-school for about thirty years, and where he died August 28, 1687. He was a man of great originality and acquirement, and has left behind him two remarkable works, *Ars Signorum*, an essay on a universal or philosophical language, and *Didascalocophus*, or the Deaf and Dumb Man's Tutor. The works of Dalgarno have been reprinted for the Maitland Club.

Dalhousie (dal-hō'zi), **FOX MAULE RAMSAY**, **EARL OF**, born 1801, served some years in the army; sat in parliament as member for the Elgin burghs and Perth; became Baron Panmure on the death of his father in 1852; was secretary at war from 1855 to 1858, when he retired from political life. In 1860, on the death of his cousin, he succeeded to the title of Earl of Dalhousie. He died in 1874 without issue, and was succeeded by his cousin, George Ramsay, twelfth Earl of Dalhousie.

Dalhousie, **JAMES ANDREW BROWN RAMSAY**, **TENTH EARL AND FIRST MARQUIS OF**, born in 1812, British statesman, was educated at Harrow and at Christchurch, Oxford. After filling the offices of vice-president (1843) and president of the board of trade (1844), he was appointed governor-

general of India (1847). In this post he showed high administrative talent, establishing railway lines, telegraphs, irrigation works, &c., on a vast scale. He greatly extended the British empire in India, annexing the Punjab, Oude, Berar, and other



Marquis of Dalhousie.

native states, as well as Pegu in Burmah. In 1849 he was made a marquis, and obtained the thanks of both houses of parliament. He outstayed his term of office to give the government the aid of his experience in the annexation of Oude; and when he returned to Europe in 1856 it was with a constitution so completely shattered that he was never able to appear again in public life, and died on 19th December, 1860. As he left no direct male issue, his marquisate expired with him.

Dalias', a town of Spain, province of Almeria, near the coast. Pop. 9000.

Dalkeith' (dal-kēth'), a town of Scotland, in the county of and 6 miles S.S.E. from Edinburgh. Iron-founding, brushmaking, brewing, and tanning are the chief industries. It has an important corn market. Here is one of the principal seats of the Duke of Buccleuch, Dalkeith Palace, built on the site of a castle for ages the chief seat of the noble family of Morton. Pop. 6931.

Dallas, a city of the U. States, in Texas, on the Trinity River, a well-built and flourishing place, and an important railroad centre. Pop. 38,067.

Dalles (dalz), the name given to various rapids and cataracts in North America. *The Great Dalles of the Columbia* are about 200

miles from its mouth, where the river is compressed by lofty basaltic rocks into a roaring torrent about 58 yards in width; the *Dalles of the St. Louis* are a series of cataracts near Duluth, Minnesota.

Dalling. See *Bulwer*.

Dalma'tia, a province of Austria, with the title of kingdom, the most southern portion of the Austrian dominions. It consists of a long narrow triangular tract of mountainous country and a number of large islands along the north-east coast of the Adriatic Sea, and bounded N. by Croatia, and N.E. by Bosnia and Herzegovina. In breadth it is very limited, not exceeding 40 miles in any part; its whole area is 4940 English square miles. The inland parts of Dalmatia are diversified by undulatory ground, hills, and high mountains; but though there are some rich and beautiful valleys, the country on the whole must be considered poor and unproductive. The Narenta, the Zermagna, the Kerka, and the Cettina are the principal rivers, all with short courses. On some of these the scenery is singularly wild and picturesque. The interior is occupied by a much-neglected population, and agriculture is in a very backward state. Timber is scarce, and the country does not produce sufficient grain for its own wants. Apples, pears, peaches, apricots, oranges, pomegranates, &c., are amongst the fruits; the wines are strong, sweet, and full-bodied. On the coast fish, especially the tunny and the sardine, abound. The trade of the country is mostly confined to the coast towns, where the population is mainly of Italian extraction. Chief of these are Zara (the capital), Sebenico, Cattaro, Spalato, and Ragusa. Amongst the numerous islands sprinkled along the coast many are valuable for their productions, such as timber, wine, oil, cheese, honey, salt, and asphalt. The population is divided between the Italians of the coast towns and the peasants of the interior, Slovenian Slavs speaking a dialect of the Slavonic. The majority are Roman Catholics. After passing successively through the hands of Hungarian and Venetian rulers, and of the first Napoleon, Dalmatia finally, in 1814, fell under Austrian rule. Pop. 1891, 527,426.

Dalmatian Dog, a variety of dog, called also the Danish, spotted, or coach dog. See *Coach-dog*.

Dalmat'ic, or DALMATICA, an ecclesiastical vestment worn by the deacon at mass, so called because it was an imitation of Dal-

matian costume. It is worn also by bishops under the chasuble. It is a long robe with large full sleeves with black or red longitudinal stripes and partially unclosed sides. A similar robe was worn by kings and emperors at high solemnities, and continues still to be worn by the sovereigns of England on such occasions.

Dal'riada, the ancient name of a territory in Antrim, called after Carbrí Riada, one of its chiefs. In the 6th century a band of Irish from this quarter settled in Argyleshire under Fergus MacErc, and founded the kingdom of the Scots of Dalriada. After being almost extinguished, the Dalriadic line revived in the 9th century with Kenneth Macalpine, and, seizing the Pictish throne, gave kings to the whole of Scotland.

Dalry', a town of Scotland, county of Ayr, on the Garnock, 19 miles s.w. of Glasgow, with ironworks and woollen and worsted mills. Pop. 5010.

Dalrym'ple, SIR DAVID, Lord Hailes, a Scottish lawyer, antiquary, and historian, born at Edinburgh in 1726. He studied at Eton and Utrecht. In 1748 he was called to the bar, and in 1766 was made a judge of the Court of Session. His publications were numerous, but consist principally of new editions and translations. Of his original productions the *Annals of Scotland* from Malcolm Canmore to the Accession of the House of Stuart, is the most important. He died Nov. 29, 1792.

Dalrymple, JAMES, first Viscount Stair, Scottish lawyer and statesman, was born in 1619. In the civil war he sided at first with the parliament, but afterwards with the royalists; was made a knight on the Restoration, and in 1671 president of the Court of Session. In 1682 he fell out of favour with the king, and retiring to Holland became an adherent of the Prince of Orange, who, after the Revolution, raised him to the peerage. He died in 1695. The connection of his son, the Master of Stair, with the massacre of Glencoe brought some odium upon him

in his last years. He wrote: *The Institutes of the Laws of Scotland* (which is still a standard authority); *Vindication of the Divine Perfections*; and *An Apology for his Own Conduct*.

Dalrymple, JOHN, first Earl of Stair, born 1648, died 1707, son of the preceding, was an able Scottish lawyer and statesman. It was through him that the massacre of Glencoe was perpetrated in 1692. He succeeded his father as viscount in 1695, and in 1703 was created earl. He was largely instrumental in bringing about the union between Scotland and England.

Dalrymple, JOHN, second Earl of Stair, born at Edinburgh in 1673. He studied at Leyden University, entered a Cameronian regiment in 1692, was aide-de-camp to Marlborough in 1702, and distinguished himself at Oudenarde, Malplaquet, and Ramilies. In 1707 he succeeded to the earldom of Stair, and in 1715-20 had a diplomatic mission to France, in which he showed great ability. After twenty years' retirement from public life, in which he did much to improve the agriculture of Scotland, in 1742 he accepted the command of the troops sent to the Continent, and was present at the battle of Dettingen, 1743. He died at Edinburgh in 1747.

Dal Segno (sen'yō; Italian), often contracted into *D.S.*, means 'from the sign.' In music this expression denotes that the singer or player ought to recommence at the place where the sign ♩ is put.

Dalton, JOHN, an English chemist and natural philosopher, born in 1766. After teaching for twelve years at Kendal, in 1793 his reputation as a mathematician won for him the chair of mathematics at the New College, Manchester. Here he continued to reside (though the college was removed in 1799), publishing from year to year valuable essays and papers on scientific subjects, while he also lectured in London, and visited Paris. In 1808 he announced (*New System of Chemical Philosophy*) his atomic theory of chemical action, the discovery of which spread his fame over Europe. Various academic and other honours were bestowed upon him, and in 1833 he received a pension of £150, afterwards increased to £300. He died July 27, 1844.

Dalton-in-Furness, a town of England, in the county of Lancaster. In its vicinity are extensive ironworks, and the ruins of the magnificent Cistercian abbey of Furness. Pop. 1891, 13,300.



Dalmatica, Cathedral of Chartres (twelfth century).

Daltonism, another name for *Colour-blindness*, which see.

Dalton's Law. See *Gas*.

Dalyell or **DALZELL** (di-el'), THOMAS, a Scottish soldier, born about 1599. He was taken prisoner fighting on the royalist side at Worcester, and afterwards escaped to Russia, where he was made a general. Returning to England at the Restoration, he was made commander-in-chief of the forces in Scotland, and made himself notorious for his ferocity against the Covenanters. He died in 1685.

Dam, a bank or construction of stone, earth, or wood across a stream for the purpose of keeping back the current to give it increased head, for holding back supplies of water, for flooding lands, or for rendering the stream above the dam navigable by increased depth. Its material and construction will depend on its situation and the amount of pressure it has to bear. For streams which are broad and deep strong materials are required, usually stone masonry bound in hydraulic cement and a strong framework of timber. The common forms of a dam are either a straight line crossing the stream transversely, or one or two straight lines traversing it diagonally, or an arc with its convex side towards the current. See *Embankment* and *Reservoir*.

Damage-feasant, in law, doing injury; trespassing, as cattle: applied to a stranger's beasts found in another person's ground, and there doing damage.

Dam'ages, in law, pecuniary compensation paid to a person for loss or injury sustained by him through the fault of another. It is not necessary that the act should have been a fraudulent one; it is enough that it be illegal, unwarrantable, or malicious. If, however, a person has suffered a loss through fraud or delict on the part of another, that person has not only a claim to ordinary damages, but may also claim remote or consequential damages, and may estimate the amount of the loss he has sustained not at its real value, but at the imaginary value which he himself may put upon it, subject, however, to the modification of a judge or a jury. In other cases the damages cover only the loss sustained estimated at its real value, together with the expenses incurred in obtaining damages.

Da'man. See *Hyrax*.

Daman (da-män'), a seaport, Hindustan, at the mouth of the Gulf of Cambay, 100 miles north from Bombay. It belongs to the Por-

tuguese, who conquered it in 1531, and made it a permanent settlement in 1558. It formerly had a large trade, but this has much declined. The settlement, which is governed under Goa, has an area of 82 sq. miles; pop. 49,084.

Damanhoor', a town of Egypt, capital of the province of Bahreh, 38 miles E.S.E. of Alexandria. It has manufactures of cotton and wool. Pop. about 10,000.

Damar', or **DEMAR'**, a town, Arabia, Yemen, 120 miles north by west of Aden. Pop. about 20,000.

Damar. See *Dammar*.

Dam'araland, a German protectorate in South Africa, extending along the Atlantic coast from Cape Frio to Walfisch Bay, and inland to 20° E. long. Area about 100,000 sq. miles, including a large amount of barren lands.

Damar Resin. See *Dammar Resin*.

Damascening. See *Damaskeening*.

Damasce'nus, JOHN, John of Damascus, afterwards called also *John Chrysorrhoeas* ('golden stream'), was born at Damascus about 676 A.D., died about 760. He was the author of the first system of Christian theology in the Eastern Church, or the founder of scientific dogmatics, and his exposition of the orthodox faith enjoyed in the Greek Church a great reputation.

Damas'cus, a celebrated city, capital of the Turkish vilayet of Syria, supposed to be the most ancient city in the world. It is beautifully situated on a plain which is covered with gardens and orchards and watered by the Barrada. The appearance of the city, as it first opens on the view, has been rapturously spoken of by all travellers; but the streets are narrow, crooked, and in parts dilapidated, and, except in the wealthy Moslem quarter, the houses are low, with flat-arched doors and accumulations of filth before the entrance. Within, however, there is often a singular contrast, in courts paved with marble and ornamented with trees and spouting fountains, the rooms adorned with arabesques and filled with splendid furniture. Among the chief buildings are the Great Mosque and the Citadel. The bazaars are a notable feature of Damascus. They are simply streets or lanes covered in with high wood-work and lined with shops, stalls, cafés, &c. In the midst of the bazaars stands the Great Khan, it and thirty inferior khans being used as exchanges or market-places by the merchants. One of the most important and busiest streets is 'Straight Street,' men-

Damiens (dā-mē-än), ROBERT FRANÇOIS, notorious for his attempt to assassinate Louis XV., was the son of a poor farmer, and born in 1715 in the village of Tieulloy. His sombre and obstinate disposition early obtained him the name of *Robert-le-Diable*. After enlisting as a soldier he became a house-servant in various establishments in Paris, and, having robbed one of his masters, he had to save himself by flight. After spending some months in different cities, in 1756 he returned to Paris with a mind which seems to have become disordered. On Jan. 5, 1757, as Louis XV. was getting into his carriage to return from Versailles to Trianon, he was stabbed by Damiens in the right side. The wound was of a trifling nature, and Damiens, who made no attempt to escape, declared he never intended to kill the king. Damiens was condemned and torn in quarters by horses March 28, 1757, on the Place de Grève at Paris.

Damiet'ta, a town of Egypt, on one of the principal branches of the Nile, about 6 miles from its mouth. It contains some fine mosques, bazaars, and marble baths. Alexandria has long diverted the great stream of commerce from Damietta, but the latter has still a considerable trade with the interior in fish and rice. The ancient town of Damietta stood about 5 miles nearer the sea. Pop. 29,383.

Dam'mar (or DAM'MARA) **Pine**, a genus of trees of the natural order Coniferæ, distinguished by their large lanceolated leathery leaves, and by their seeds having a wing on one side instead of proceeding from the end. The *Dammāra orientālis* is a lofty tree of the East India Archipelago, attaining on some of the Molucca Islands a height of from 80 to 100 feet. It yields one variety of dammar resin. (See next art.) The Kauri pine, or *Dammāra austrālis*, found in the North Island of New Zealand, is a magnificent tree, rising to a height of 150 to 160 feet, and yielding kauri gum. See *Kauri*.

Dammar Resin, a gum or resin of several kinds produced by different trees. The East Indian or cat's-eye resin is got from the *Dammāra orientālis*, a tree of the East Indian islands (see above), and is used for making varnishes for coach-builders, painters, &c. In its native localities it is burned as incense, and is also used for caulking ships. *Sal* dammar is produced by the sal tree of India (*Shorēa robusta*), *rock* dammar by *Hopēa odorāta* and other species of trees;

both yield good varnishes. *Black dammar* is another Indian species.

Dammoo'da, a river of Hindustan, presidency of Bengal, which enters the Hooghly near its mouth; length 350 miles.

Dam'ocles, a native of Syracuse, and one of the courtiers and flatterers of the tyrant Dionysius the elder. One day he was extolling the grandeur and happiness of Dionysius, whereupon the latter invited him to a magnificent banquet, where he would be regaled with regal fare and regal honours. In the midst of the entertainment, however, Damocles happened to look upwards, and perceived with dismay a naked sword suspended over his head by a single hair, and was thus taught to form a better estimate of royal honours.

Damon and Pythias, two illustrious Syracusans, celebrated as models of constant friendship. Pythias had been unjustly condemned to death by Dionysius the younger, tyrant of Sicily; but, having to leave Syracuse to arrange his affairs, his friend Damon was taken as a pledge that Pythias should return on the day fixed. Pythias, however, being unexpectedly detained, had great difficulty in reaching Syracuse in time to save Damon being executed in his place; and Dionysius was so affected by this proof of their friendship that he pardoned Pythias.

The Knights of Pythias, a fraternal order established in the United States, has this pleasant incident for its basis. Its growth has been remarkably rapid, and Lodges are in existence in every State of the Union.

Dam'pier, WILLIAM, English navigator, born in 1652. He was descended from a good family in Somersetshire; but losing his father when young, he was sent to sea, and soon distinguished himself as an able mariner. After serving in the Dutch war, in the Bay of Campeachy as a logwood-cutter, in a band of privateers on the Peruvian coasts, in a Virginian expedition against the Spanish settlements in the South Seas, and other enterprises of a similar nature, he returned home in 1691. In 1697 he published his Voyage Round the World, which became very popular, and next year he was appointed commander of a royal sloop-of-war, fitted out for a voyage of discovery in the Australian seas. The vessel, on the home voyage (1700), foundered off the isle of Ascension, and Dampier returned to England. In 1703 he sailed for the South Sea in command of a

privateer, returning in 1707; and next year he shipped as pilot with Captain Woodes Rogers, and accompanied him on his voyage round the world. He died in 1715. Be-



William Dampier.

sides the book mentioned, he wrote *Voyages and Descriptions*, a supplement to it, and *Voyage to New Holland*. He was an excellent hydrographer, and a keen observer.

Damps, noxious exhalations issuing from the earth, and deleterious or fatal to animal life. Damps exist in wells which continue long covered and not used, and in mines and coal-pits; and sometimes they issue from the old lavas of volcanoes. These damps are distinguished by miners under the names of *choke-damp*, consisting chiefly of carbonic acid gas, which instantly suffocates; and *fire-damp*, consisting chiefly of light carburetted hydrogen, so called from its tendency to explode.

Dam'son, a variety of the common plum (*Prunus domestica*). The fruit is rather small and oval, and its numerous sub-varieties are of different colours: black, bluish, dark purple, yellow, &c. The damson (corruption of Damascene), as its name imports, is from Damascus.

Dan (Hebrew, meaning 'judgment'), one of the sons of Jacob by his concubine Bilhah. At the time of the exodus the Danites numbered 62,700 adult males, being then the second tribe in point of numbers. Samson was a member of this tribe.

Dana, CHARLES ANDERSON, editor, was born in Hinsdale, N. H., Aug. 8, 1819. After association with the N. Y. Tribune for 14 years as one of the proprietors and

managing editor, in 1863, was appointed Assistant Secretary of War. Since 1868 Mr. Dana was the editor of the N. Y. Sun. Perhaps more than any other journalist his personality was identified with his newspaper. He died Oct. 17, 1897.

Da'na, JAMES DWIGHT, American naturalist, born 1813, and since 1855 a professor at Yale College. He has written *System of Mineralogy*; *Manual of Mineralogy*; *Coral Reefs and Islands*; *Manual of Geology*; *Text-book of Geology*; and many reports and papers.

Dana, RICHARD HENRY, American writer, born 1787 at Cambridge in Massachusetts; educated at Harvard; published several collections of poems and two novels. He died in 1879.—His son Richard Henry (born 1815, died 1882) was the author of the well-known work *Two Years before the Mast*, the result of his own experiences during a voyage recommended to him on account of his health.

Dan'aë, in Greek mythology, daughter of Acrisius, king of Argos. She was shut up by her father in a brazen tower, but Zeus, inflamed with passion for her, transformed himself into a golden shower, and descended through the apertures of the roof into her embraces. Set adrift on the waves by her father, she reached safely one of the Cyclades, where her child, Perseus, was brought up.

Dan'bury, a town in Connecticut, about 53 miles N.N.E. of New York. It has notable manufactures of hats, shirts, and sewing-machines. Pop. 1890, 16,552.

Danby, FRANCIS, painter, born near Wexford in 1793. He established his reputation in 1823 by his *Sunset at Sea after a Storm*; and in 1825, by his *Delivery of Israel out of Egypt*, obtained the honour of being admitted as an associate of the Academy. Among his subsequent pictures the most celebrated are the *Opening of the Sixth Seal*, exhibited in 1828; the *Age of Gold*, in 1831; *The Enchanted Island—Sunset*, in 1841; *The Contest of the Lyre and Pipe in the Vale of Tempe*, in 1842; and the *Painter's Holiday*, in 1844. Danby's excellence lay in his delineations of scenery, and the poetic halo with which he contrived to invest them. He died in 1861.

Dance of Death. See *Death, Dance of*.

Dancing, a studied and rhythmical movement of the limbs generally adjusted to the measure of a tune. In ancient times it was generally an expression of religious, patriotic, or military feeling, as in the case of the

dance of David before the ark, the choric dances, or the Pyrrhic dance of the Greeks. The Romans, however, like the orientals, had their dancing done by hired slaves. This solemn character of the dance has declined with the progress of refinement and civilization, and it is now nothing more than an elegant social amusement and an agreeable spectacle at public entertainments. As a social amusement, something can be said both for and against dancing. It is a pleasantly animated indoor physical exercise, and helps to give grace to the ordinary movements of the body. It can be urged against it that, as an exercise, it takes place most frequently when the body should be in repose, and under circumstances not very favourable to health, such as overcrowded and overheated rooms, &c. It is, therefore, though in itself a healthy amusement, peculiarly liable to abuse.

Dancing Disease, an epidemic nervous disorder apparently allied to hysteria and chorea, occasionally prevalent in Germany and Italy during the middle ages. In 1734, during the celebration of the festival of St. John at Aix-la-Chapelle, the streets became crowded with men and women of all ranks and ages, who commenced dancing in a wild and frantic manner till they dropped down from fatigue. The mania spread to Cologne, Metz, and Strasburg, and gave rise to much imposture, profligacy, and disorder. At the beginning of the 17th century the epidemic began to decline, and is only known now as a nervous affection in individual cases.

Dandeli'on (*Leontödon Taraxäcum*), a plant belonging to the natural order Compositæ, indigenous to Europe, but now also common in America. The leaves are all radical, and runcinate or jagged on the margin. From this circumstance has been derived its French name *dent de lion* (lion's tooth), of which the English appellation is a corruption. The stems are hollow and have one large bright-yellow flower and a tapering milky perennial root, which acts as an aperient and tonic, and is much esteemed in affections of the liver. The whole plant is full of a milky and bitter juice. (See *Taraxacin*.) The seed of the plant is furnished with a white pappus, and is transported far and wide by the wind.

Dandie Dinmont Terrier, a peculiar breed of the Scotch terrier, so called from the Border farmer of that name who figures in Scott's novel of Guy Mannering. This breed is known by its short legs, wiry and

abundant hair, and large ears. It is very courageous when fully grown. It is usually either of a light-brown or a bluish-gray colour, termed respectively the 'Mustard' and the 'Pepper' variety.

Dan'dolo, ANDREA, Doge of Venice and of an illustrious Venetian family, was born about 1310, and made doge in 1343. He carried on a war against the Turks with various success, and greatly extended Venetian commerce by opening a trading connection with Egypt. He wrote a chronicle of Venice, comprising the history of the republic from its commencement to 1342, which was published in Muratori's collection. He died in Sept. 1354.

Dandolo, ENRICO, Doge of Venice, was chosen to that office in 1192, at the advanced age of eighty-four. On the formation of the fourth Crusade Dandolo induced the senate to join in it, and by its help recovered the revolted town of Zara. Constantinople was next stormed, the blind old doge, it is said, leading the attack. In the division of the Byzantine Empire the Venetians added much to their dominions. Dandolo died at Constantinople in 1205, at the age of ninety-seven.

Danebrog, DANNEBROG (*dän'é-brog*), literally 'the cloth or banner of the Danes,' a Danish order of knighthood, said to have been instituted in 1219, and revived in 1693. The decorations consist of a cross of gold *pattée*, enamelled with white, and suspended by a white ribbon embroidered with red.

Dane'gelt, DANE'GELD (that is, 'Danetax'), in English history, an annual tax laid on the English nation for maintaining forces to oppose the Danes, or to furnish tribute to procure peace. It was at first one shilling, and ultimately seven, for every hide of land, except such as belonged to the church. When the Danes became masters of England the *danegelt* was a tax levied by the Danish princes on every hide of land owned by the Anglo-Saxons.

Dane'lagh, DANELAW, the ancient name of a strip of territory extending along the east coast of England from the Thames to the Tweed, ceded by Alfred to Guthrun, king of the Danes, after the battle of Ethandune. This name it retained till the Norman conquest, its inhabitants being governed by a modification of Danish law and not by English law.

Danewerk (*dä'ne-verk*; Ger. 'Danes' work'; Danish, *Dannevirke*), an ancient wall of about from 30 to 40 ft. high and of an

equal thickness extending along the southern frontier of Schleswig for nearly 10 miles, from the North Sea to the Baltic. It was constructed in the middle of the 10th century and repaired in 1850, but was captured by the Austrians and Prussians in the Schleswig-Holstein war of 1864 and soon after destroyed.

Dan'iel, the prophet, a contemporary of Ezekiel, was born of a distinguished Hebrew family. In his youth, B.C. 605, he was carried captive to Babylon, and educated in the Babylonish court for the service of King Nebuchadnezzar. Thrown into the lions' den for conscientiously refusing to obey the king he was miraculously preserved, and finally made prime-minister in the court of the Persian king Darius. He ranks with what are called the 'greater prophets.' The book of the Old Testament which bears his name is divided into a historical and a prophetic part. Modern criticism generally regards it as written during the oppression of the Jews under Antiochus, about 170 B.C. It is partly in Chaldee.

Daniel, SAMUEL, an English historian and poet, contemporary with Shakspeare, was born in 1562. Under the patronage of the Pembroke family he received several court appointments, but he commonly lived in the country, employed in literary pursuits. His great poem, *The History of the Civil Wars between the Houses of York and Lancaster*, is written with much rhetorical grace and dignity of style. He wrote also epistles, pastorals, sonnets, and a few tragedies, as well as a clear and useful sketch of English history till the time of Edward III. He died in 1619.

Dan'iel, JOHN FREDERICK, a distinguished English physicist, born at London March 12, 1790. In 1816 he commenced the *Quarterly Journal of Science and Art* in concert with Mr. Brande. In 1820 he published an account of a new hygrometer which he had invented. Soon afterwards his valuable works, *Meteorological Essays* and the essay on *Artificial Climate*, appeared. In 1831 he was appointed professor of chemistry in King's College, London, and made further important discoveries, chief amongst which is his apparatus for maintaining a powerful and continuous current of electricity in galvanic batteries (see following article). For these discoveries he received successively the three medals in the gift of the Royal Society. In 1843 he was made a D.C.L. of Oxford. He died 13th March, 1845.

Daniell's Battery, a galvanic battery the cells of which were originally constructed in the following way. A tall cylindrical copper vessel was nearly filled with saturated solution of sulphate of copper. A rod of amalgamated zinc was inclosed in a skin or

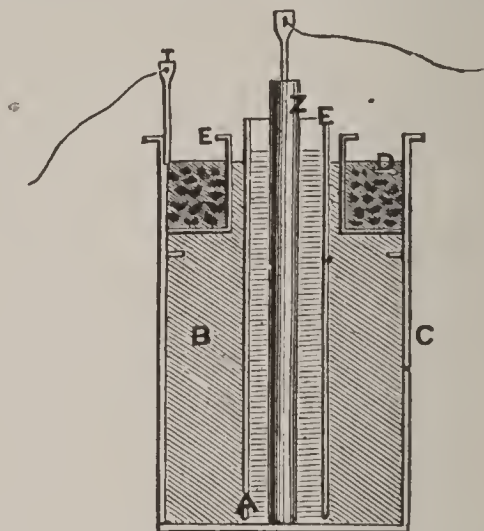

Daniell's Battery.—Section of Cell.

c, Outer copper cell. B, Solution of sulphate of copper. D, Shelf for sulphate of copper. E, Porous cell. A, Sulphuric acid. z, Zinc.

bladder, which was filled with dilute sulphuric acid, and was suspended in the copper cylinder. When the zinc rod is connected by a wire with the copper vessel, which itself forms one of the plates of the battery, the current passes, according to common phraseology, from the copper through the wire to the zinc. Instead of the bladder or skin porous earthenware pots are now employed to contain the dilute sulphuric acid in which the zinc is immersed. In improved modifications of Daniell's battery the most important change is that of substituting for the dilute sulphuric acid that surrounds the zinc, solution of sulphate of zinc, and in this case the zinc is not amalgamated. By doing away with the sulphuric acid local waste of the zinc is to a great extent prevented, and the solution of sulphate of zinc is used instead of pure water on account of the very high resistance of water impregnated with salts.

Danish Language and Literature. See *Denmark*.

Dankali', or DANA'KIL (the former is the Arabic singular, the latter the plural), the common name of a number of rude tribes that inhabit Africa east of Abyssinia, between it and the Red Sea, bordering on the south with the Somalis. Some engage in fishing, others in the rearing of cattle. They are of the Mohammedan religion, and are estimated to number 70,000.

Dannebrog. See *Danebrog*.

Dan'necker, JOHANN HEINRICH, German sculptor, born in 1758. Early signs of talent recommended him to the notice of Charles, duke of Württemberg. As a student at the Karlschule he greatly distinguished himself, was appointed court sculptor, and visited Paris and Rome. In 1790 he returned to Württemberg, and became professor of the fine arts at Stuttgart. His best works are his statue of Christ and his *Ariadne Seated on a Panther*. His portrait busts are excellent; those of Schiller, Lavater, the Duchess Stephanie of Baden, deserve particular mention. Dannecker died in 1841.

Dannemo'ra, a village, on a lake of the same name, 24 miles N.N.E. of Upsala, in Sweden, celebrated for its iron-mines, the second richest in Sweden, which have been worked uninterruptedly for upwards of three centuries, and produce the finest iron in the world.

Dante (a contraction of *Durante*) **Alighieri** (dàn'tā à-lē-gē-ā'rē), the greatest of Italian poets, was born in Florence about the end of May 1265, of a family belonging to the lower nobility. His education was confided to the learned Brunetto Latini. He is said also to have studied in various seats of learning, and it is certain that either at this time or in the course of his wandering life he made himself master of all the knowledge of his time. He seems to have been quite a boy, no more than nine years of age, when he first saw Beatrice Portinari, and the love she awakened in him he has described in that record of his early years, the *Vita Nuova*, as well as in his later great work, the *Divina Commedia*, in terms which make it hard to distinguish the real personality of Beatrice from some ideal power of beauty and virtue of which she is to Dante the symbol. Their actual lives at least went far enough apart, Beatrice marrying a noble Florentine, Simone Bardi, in 1287, and dying three years afterwards; while the year following Dante married Gemma dei Donati, by whom he had seven children. At this time the Guelphic party in Florence became divided into the rival factions of Bianchi and Neri (Whites and Blacks), the latter being an extreme papal party while the former leaned to reconciliation with the Ghibellines. Dante's sympathies were with the Bianchi, and being a prior of the trades and a leading citizen in Florence he went on an embassy to Rome to

influence the pope on behalf of the Bianchi. The rival faction of the Neri, however, had got the upper hand in the city, and in the usual fashion of the time were burning the houses of their rivals and slaying them in the open street. In Dante's absence his

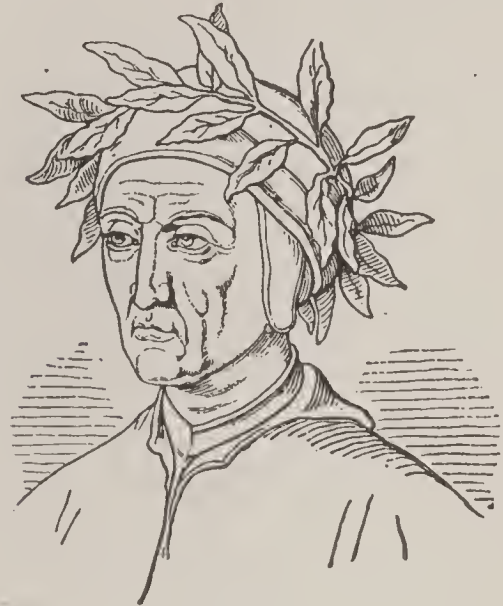

Dante.

enemies obtained a decree of banishment against him, coupled with a heavy fine, a sentence which was soon followed by another condemning him to be burned alive for malversation and peculation. From this time the poet became, and to the end of his life remained, an exile; and his history, first lost by the indifference of contemporaries and then hallowed by the legends of later generations, becomes semi-mythical. He has told us himself how he wandered 'through almost all parts where this language is spoken,' and how hard he felt it 'to climb the stairs and eat the bitter bread of strangers.' During this period he is said to have visited many cities, Arezzo, Bologna, Sienna, &c., and even Paris. In 1314 he found shelter with Can Grande della Scala at Verona, where he remained till 1318. In 1320 we find him staying at Ravenna with his friend Guido da Polenta. In Sept. 1321 his sufferings and wanderings were ended by death. He was buried at Ravenna, where his bones still lie. His great poem, the *Divina Commedia* (Divine Comedy), written in great part, if not altogether, during his exile, is divided into three parts, entitled Hell, Purgatory, and Paradise. The poet dreams that he has wandered into a dusky forest, when the shade of Virgil appears and offers to conduct him through hell and purgatory. Fur-

ther the pagan poet may not go, but Beatrice herself shall lead him through paradise. The journey through hell is first described, and the imaginative power with which the distorted characters of the guilty and the punishments laid upon them are brought before us; the impressive pathos of these short histories—often compressed in Dante's severe style into a couple of lines—of Pope and Ghibelline, Italian lord and lady; the passionate depth of characterization, the subtle insight and intense faith, make up a whole which for significance and completeness has perhaps no rival in the work of any one man. From hell the poet, still in the company of Virgil, ascends to purgatory, where the scenes are still mostly of the same kind though the punishments are only temporary. In the earthly paradise Dante beholds Beatrice in a scene of surpassing magnificence, ascends with her into the celestial paradise, and after roaming over seven spheres reaches the eighth, where he beholds 'the glorious company which surrounds the triumphant Redeemer.' In the ninth Dante feels himself in presence of the divine essence, and sees the souls of the blessed on thrones in a circle of infinite magnitude. The Deity himself, in the tenth, he cannot see for excess of light. There are many notable translations of Dante's great poem. Amongst English versions we may mention those of Cary, Longfellow, and Dean Plumptre, and an excellent prose translation by Dr. John Carlyle. The *Vita Nuova* has been admirably translated by D. G. Rossetti in his *Early Italian Poets*. Dante's other works are: *Il Convito* (the Banquet), a series of philosophical commentaries on the author's canzoni; *Il Canzoniere*, a collection of poems; a Latin treatise, *De Monarchia*, a work intended to prove the supremacy of the head of the holy Roman Empire; a treatise on the Italian language entitled, *De Vulgari Eloquio*; and an inquiry into the relative altitude of the water and the land, *De Aqua et Terra*.

Danton (dān-tōn), GEORGES JACQUES, an advocate by profession, and one of the great figures in the French Revolution, born 1759. His colossal stature, athletic frame, and powerful voice contributed not a little, together with his intellectual gifts and audacity, to win him a prominent position amongst the revolutionaries. He founded the club of the Cordeliers, was foremost in organizing and conducting the attack on the Tuileries, Aug. 10th, 1792, and as a reward for

such services was made minister of justice and a member of the provisional executive council. When the advance of the Prussian army spread consternation amongst the members of the government Danton alone preserved his courage, and in a celebrated speech summoned all Frenchmen capable of bearing arms to march against the enemy. He voted for the capital punishment of all returning aristocrats, but undertook the defence of religious worship, and along with Robespierre brought Hébert and the worshippers of the goddess Reason to the scaffold. But the rivalry of the two great leaders had now reached a point when one must succumb, and the crafty Robespierre succeeded in having Danton denounced and thrown into prison, 31st March, 1794. Five days afterwards he was condemned by the revolutionary tribunal as an accomplice in a conspiracy for the restoration of monarchy, and executed the same day.

Dantzic, or **DANZIG** (dānt'zih), a fortified town and port, Prussia, capital of the province of West Prussia, 253 miles N.E. Berlin, on the left bank of the west arm of the Vistula, about 3 miles above its mouth in the Baltic, and intersected by the Mottlau,



which here divides into several arms. It is one of the most important seaports in the Prussian monarchy. The more modern parts are regularly and well built; in the other parts the streets are narrow and the houses old and indifferent. Amongst the principal buildings are the Dom or Cathedral, begun in 1343, the church of St. Catherine, the exchange, the arsenal, observatory, three monasteries, two synagogues, two theatres, &c. The industries are numerous, but, excepting those connected with shipbuilding, artillery, and beer, not

DANTZIG — DANUBE

of great importance. The prosperity of the town is founded chiefly on its transit trade, particularly in wheat from Poland. There is also a considerable trade in amber. The proper port of Dantzig is Neufahrwasser, at the mouth of the Vistula; but vessels of large size can now come up to and enter the town. After being alternately possessed by the Teutonic knights and the

Poles, Dantzig, on the partition of Poland, fell to Prussia. Pop. 1890, 120,459.

Dan'ube (anc. *Ister* or *Danubius*; German, *Donau*), a celebrated river of Europe, originates in two small streams rising in the Schwarzwald, or Black Forest, in Baden, and uniting at Donaueschingen. The direct distance from source to mouth of the Danube is about 1000 miles, and its total

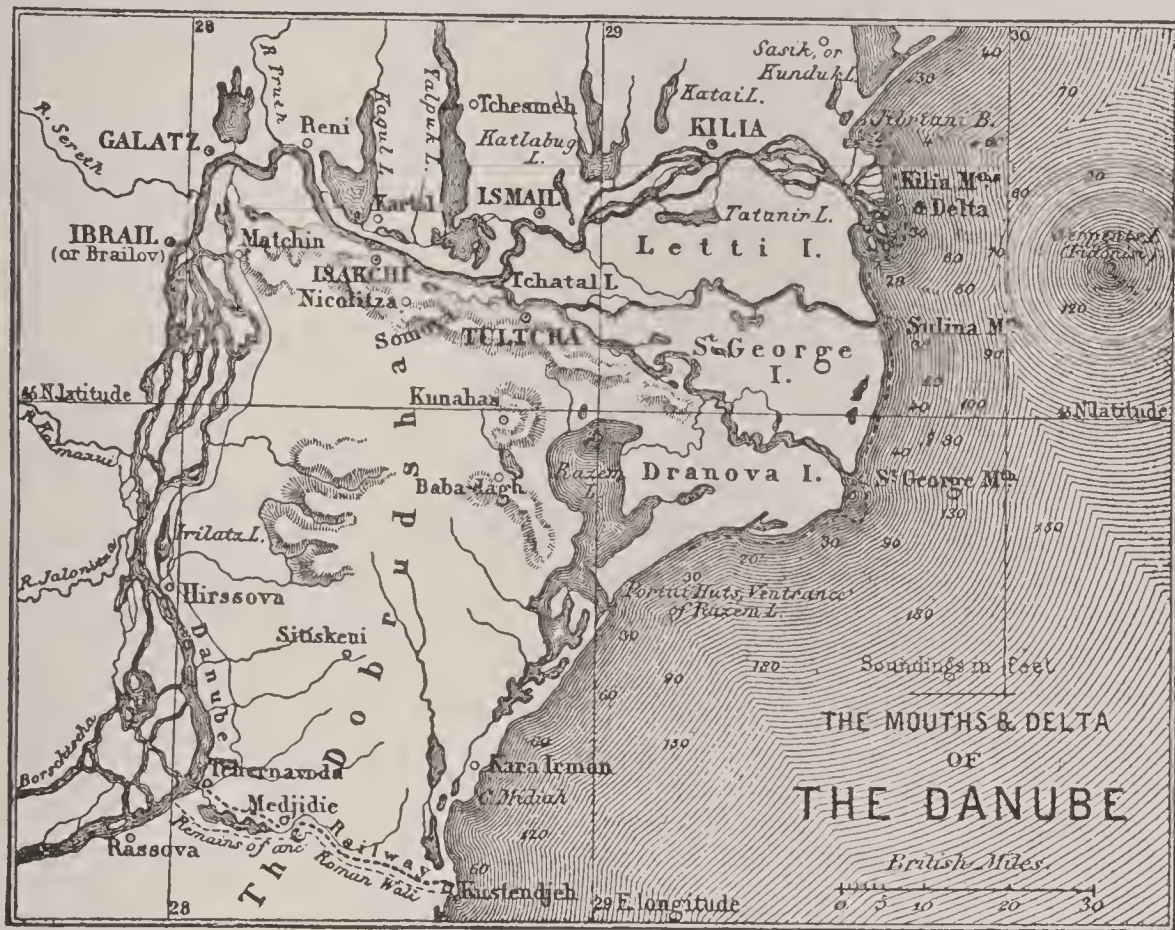

length, including windings, about 1670 miles. From its source the Danube flows in a north-easterly direction to Ulm, in Würtemberg, where it becomes navigable for vessels of 100 tons; then to Ratisbon in Bavaria, where it becomes navigable for steamers. Here it turns in a south-easterly direction, entering Austria at Passau, passing Vienna and Budapest, above which latter town it suddenly turns due south, holding this direction till it is joined by the Drave, after which it runs s.s.e. and enters Servia at Belgrade. Continuing its general course eastward it forms for a long distance the boundary line between Roumania and Bulgaria. At Sili-stria it once more turns northward, and flowing between Roumania and Bessarabia falls into the Black Sea by three different outlets. In the upper part of its course, through Würtemberg and Bavaria, the Danube flows through some of the most fer-

tile and populous districts of its basin. Its principal affluents here are the Iser and Lech. In Austria it passes through a succession of picturesque scenery till past Vienna, the land on both sides being well peopled and cultivated. The principal affluents are the March, or Morawa, and the Ens. After passing through what is called the Carpathian Gate, at Pressburg, where it enters Hungary, it gives off a number of branches, forming a labyrinth of islands known as Schütten, but on emerging it flows uninterruptedly southwards through wide plains interspersed with pools, marshes, and sandy wastes. The principal affluents here are the Save, the Drave, and the Theiss. Sixty miles before entering Roumania the river passes through a succession of rapids or cataracts which it has made in cutting a passage for itself through the cross chain of hills which connect the Carpa-

thian Mountains with the Alps. The last of these cataracts, at Old Orsova, is called the Iron Gate. The lower course of the Danube, in Roumania and Bulgaria, is through a flat and marshy tract, fertile but badly cultivated and thinly peopled. In this part it increases its width from 1400 to 2100 yards, and latterly forms an expanse like a sea, and is studded with islands. Of the three outlets the Sulina Mouth is the deepest, and is usually chosen by ships bound up the river. The Danube is navigable for steamers up to Regensburg (Ratisbon), nearly 1500 miles from its mouth. Some of its tributaries, such as the Save, the Theiss, and the Drave, are also navigable, so that the water system of the Danube may be estimated as admitting of about 2500 miles of steam navigation.

Danubian Principalities. See *Roumania*.

Dan'vers, a town of the U. States, Massachusetts, 15 miles N.N.E. of Boston, with tanneries, manufactures of boots and shoes, &c. Pop. 1890, 7454.

Dan'ville, three towns, U. States. (1) In Illinois; coal-mines, &c. Pop. 11,491.—(2) In Pennsylvania; blast-furnaces, rolling-mills, &c. Pop. 7998.—(3) In Virginia; an important tobacco centre. Pop. 10,305.

Daoudnagar. See *Daudnagar*.

Daph'nē, the Greek name for laurel, in Greek mythology a nymph beloved by Apollo. Deaf to the suit of the god, and fleeing from him, she besought Zeus to protect her. Her prayer was heard, and at the moment Apollo was about to encircle her in his arms she was changed into a laurel, a tree thenceforth consecrated to the god.

Daph'ne, a genus of plants, natural order Thymelacæ. They are shrubs, inhabiting the greater part of the northern hemisphere, but chiefly the south of Europe and the warmer parts of Asia. The best known is the mezereon (*D. Mezerëum*), with pale-green leaves and very fragrant flowers. *D. Laureola* (spurge laurel) has an irritant bark, and its berries are poisonous.

Daph'nia, the water-flea, a genus of minute crustaceans belonging to the division Branchiopoda. The best-known species is the *D. pulex*, or 'branch-horned' water-flea, which is a favourite microscopic object. The head is prolonged into a snout, and is provided with a single, central, compound eye; it is also furnished with antennæ, which act as oars, propelling it through the water by a series of short springs or jerks. These animals are very abundant in many ponds

and ditches; and as they assume a red colour in summer impart the appearance of blood to the water.

Darab', or DARABJERD, a town, Persia, province of Farsistan, beautifully situated in an extensive plain among groves of dates, oranges, and lemons, 140 miles south-east of Shiraz. Pop. from 15,000 to 20,000.

Darbhā'gah, a town of Hindustan, in the Patná division of Behar, in a low-lying district subject to inundation; it is the residence of the Maharaja of Darbhāgah, who has a fine new palace here. Pop. 65,955.

D'Arblay, MADAME. See *Burney*.

Dar'danelles (-nelz; anc. *Hellespont*), a narrow channel which connects the Sea of Marmora with the Grecian Archipelago, and at this particular point separates Europe from Asia. It is about 40 miles in length, and varies in breadth from 1 to 4 miles. A rapid current often much increased by winds runs southward. On the Asiatic side the country is fine and fertile, rising gradually upwards from the sea to the range of Mount Ida; the European side is steep and rugged, but densely peopled and highly cultivated. On both shores there are numerous forts and batteries. Two castles on the opposite shores occupy the sites of ancient Sestos and Abydos, and recall the story of Hero and Leander. By treaty made in 1841 between the five great powers and Turkey, confirmed by the Peace of Paris in 1856, it is settled that no non-Turkish man-of-war shall pass the strait without the express permission of the Turkish government.

Dar'danus, in Greek mythology, the progenitor of the Trojans.

Darfur', or DARFOOR', a considerable region of Central Africa, forming a large oasis in the S.E. corner of the Great Desert. It may be considered as lying between lat. 11° and 15° N., and long. 26° and 29° E.; on the east it has Kordofan and on the west Bornou, while the regions to the south are occupied by barbarous nations. The inhabitants are Mohammedans and negroes, and semi-barbarous. Their occupation is chiefly agriculture, and cattle form their principal wealth. The commerce with Egypt is extensive, and is carried on entirely by the African system of caravans. It exports slaves, ivory, ostrich feathers, gum, copper, &c., and receives in exchange sugar, cotton cloth, hardware, fire-arms, &c. Unlimited polygamy is allowed, and the morals and manners of the natives are of a very degraded

kind. Pop. estimated at four or five millions.

Daric, an ancient Persian gold coin of Darius, weighing about 129 grains, value about \$6., and bearing on one side the figure



Golden Daric, from British Museum.

of an archer. In later times the name has been applied to a silver coin having the figure of an archer.

Da'rien, GULF OF, a gulf of the Caribbean Sea at the north extremity of South America, between the Isthmus of Panamá and the mainland.

Darien, ISTHMUS OF, often used as synonymous with the Isthmus of Panamá, but more strictly applied to the neck of land between the Gulf of Darien and the Pacific.

Darien Scheme, a celebrated financial project, conceived and set afloat by William Paterson, a Scotsman, towards the close of the 17th century. Paterson was a man of bold and original conceptions, and possessed of a wide knowledge of commerce and finance. He was the first projector of the Bank of England, but was disappointed of his just recompense. His next scheme was one of magnificent proportions. He proposed to form an emporium on each side of the Isthmus of Darien or Panamá for the trade of the opposite continents. The settlement thus formed would become the entrepôt for an immense exchange between the manufactures of Europe and the produce of South America and Asia. Paterson had designed to limit the benefits of the scheme to Scotland mainly, but had to seek help in London, where the subscriptions soon ran up to £300,000. Alarm was soon excited amongst the English merchants, especially those connected with the Indies, at the gigantic Scotch scheme, and the English subscriptions were withdrawn. Scotland, indignant at this treatment, subscribed at once and with great enthusiasm £400,000, a full half of all the cash in the kingdom. Little more than the half, however, was paid up. In 1698 five large vessels laden with stores, &c., and with 1200 intending colonists, sailed for the Isthmus of Darien. The

settlement was formed in a suitable position, and the colonists fortified a secure and capacious harbour; but nothing else had been rightly calculated. Many of the colonists were gentlemen, totally unacquainted with any of the arts necessary in a new colony; the provisions were either improper for the climate or soon exhausted; the merchandise they had brought was not adapted for the West Indian market. To add to their difficulties the colonists were attacked by the Spaniards and all commerce forbidden with them. For eight months the colony bore up, but at the end of that time the survivors were compelled by disease and famine to abandon their settlement and return to Europe. Two of the ships were lost on the way home, and only about thirty, including Paterson, reached Scotland.

Dari'us, the name of several Persian kings. (1) **DARIUS I.**, fourth king of Persia, son of Hystaspes, a prince of the royal family of the Achæmenidæ, attained the throne in B.C. 521. His reign was distinguished by many important events. He reduced, after a two years' siege, the revolted city of Babylon, and led an expedition of 700,000 men against the Scythians on the Danube, from which he extricated himself after suffering great losses. To revenge himself against the Athenians who had promoted a revolt of the Ionian cities, he sent an army under Mardonius to invade Greece. But the ships of Mardonius were destroyed by a storm in doubling Mount Athos (492 B.C.), and his army was cut to pieces by the Thracians. Darius, however, fitted out a second expedition of 500,000 men, which was met on the plains of Marathon by an Athenian army 10,000 strong, under Miltiades, and completely defeated (490 B.C.). Darius had determined on a third expedition when he died B.C. 485.—(2) **DARIUS II.**, surnamed *Nothos*, or the Bastard, by the Greeks, an illegitimate son of Artaxerxes I. (*Longimānus*). He ascended the throne in 423, and died in 404. His son Cyrus is familiar to us through Xenophon's *Anabasis*.—(3) **DARIUS III.**, surnamed *Codomannus*, great-grandson of Darius II., was the twelfth and last king of Persia. He ascended the throne B.C. 336, when the kingdom had been weakened by luxury and the tyranny of the satraps under his predecessors, and could not resist the attacks of a powerful invader. Such was Alexander of Macedon; and the army which was sent against him by Darius was totally routed on the banks of the

Granicus, in Asia Minor. Darius then hastened with 400,000 soldiers to meet Alexander in the mountainous region of Cilicia, and was a second time totally defeated near the Issus, B.C. 333. Two years afterwards, all proposals for peace having been rejected by Alexander, Darius collected a second army, and meeting the Macedonian forces between Arbela and Gaugamela was again routed and had to seek safety in flight (331 B.C.). Alexander now captured Susa the capital, and Persepolis, and reduced all Persia. Meanwhile Darius was collecting another army at Ecbatana in Media, when a traitorous conspiracy was formed against him by which he lost his life in 330 B.C. Alexander married his daughter Statira.

Darjeel'ing, or **DARJILING**, a district of India, in the extreme north of the lieutenant-governorship of Bengal, division of Cooch-Bihar; area, 1234 sq. miles. Tea, coffee, cinchona, and cotton are cultivated more or less, and the cultivation of the tea-plant and the making of tea is now the staple industry. Pop. 155,179.—**DARJEELING**, the chief town in the district, is a sanatory station for the British troops, and though little more than 36 miles from the plains stands at an elevation of 7400 ft. above sea-level, on a ridge with deep valleys on either side, in a bleak but healthy situation. There is a residence of the lieutenant-governor, barracks, a sanitarium, &c. Pop. 7018, much increased in the hot weather.

Dar'laston, a town and parish, England, county and 17 miles s. by e. of Stafford. It has extensive coal and iron mines. Pop. 1891, 14,422.

Darling (from a governor of N. South Wales), a name of several applications in Australia. The *Darling River*, a river rising in the N.E. of New South Wales, flows in a south-westerly direction till it joins the Murray.—*Darling District* is a pastoral district, about 50,000 sq. miles in extent, in the s.w. of New South Wales, and watered by the Darling and the Murray.—The *Darling Downs* are a rich table-land west of Brisbane in Queensland. It is well watered, and measures about 6000 sq. miles.—The *Darling Range* is a range of granite mountains in Western Australia, running in a northerly direction parallel with the coast from Point D'Entrecasteaux for 250 miles.

Darling, **GRACE**, a celebrated English heroine, was born in 1815 in the Longstone Lighthouse (Farne Islands, coast of Northumberland), of which her father was keeper.

In 1838 the steamer *Forfarshire*, with forty-one passengers on board besides her crew, became disabled off the Farne Islands during a storm, and was thrown on a rock where she broke into two, part of the crew and passengers being left clinging to the wreck. Next morning William Darling descried them from Longstone, about a mile distant, but he shrank from attempting to reach the wreck through a boiling sea in a boat. His daughter Grace, however, implored him to make the attempt and let her accompany him. At last he consented, and father and daughter each taking an oar, they reached the wreck and succeeded in rescuing nine sufferers. The news of the heroic deed soon spread, and the brave girl received testimonials from all quarters. A purse of £700 was publicly subscribed and presented to her. Four years afterwards she died of consumption, 20th October, 1842.

Dar'lington, a municipal and parliamentary borough (with one member), England, county and 17½ miles south of Durham; well built, chiefly of brick. The woollen manufacture is carried on to a considerable extent, and there are large iron-works, and works manufacturing steel, locomotive engines, iron bridges, &c. Pop. 38,000.

Darlingto'nia, a remarkable genus of American pitcher-plants, nat. order Sarraceniacæ. A single species is known from California. The leaves are long and trumpet-shaped, with a wing rising from one side of the mouth.

Darmstadt (därm'stät), a town, Germany, capital of the Grand-duchy of Hesse, in a sandy plain, on the Darm, 15 miles s. Frankfurt. It consists of an old and a new town. The former, which is the business part of the town, is very poorly built; the houses are old, and the streets narrow and gloomy. The new town is laid out with great regularity, and has handsome squares and houses. Among the remarkable buildings are the old palace (with a library of 500,000 volumes and 4000 MSS., a picture-gallery, and a rich museum of natural history), the Roman Catholic Church, and the Rathhaus or town-hall built in 1580. Darmstadt has some iron-foundries, breweries, &c., but depends more upon the residence of the court than upon either trade or manufactures. Pop. 1890, 56,390.

Darmstadt, or **HESSE-DARMSTADT**. See *Hesse*.

Dar'nel, the popular name of *Lolium temulentum*, a species of poisonous grass. It appears to be the *infelix lolium* of Virgil,

and the tares of Scripture. Its properties are said to be narcotic and stupefying, but recent researches have cast some doubt on its reported deleterious qualities. It is met with in corn-fields, and is now naturalized in N. America.

Darnétal (dâr-nâ-tâl), a town, France, dep. of Seine-Inférieure, 2½ miles east of Rouen. There are extensive woollen factories and spinning-mills. Pop. 6487.

Darnley, HENRY STUART, LORD, son of the Earl of Lennox and Lady Margaret Douglas, a niece of Henry VIII., and by her first marriage queen of James IV., born 1541. In 1565 he was married to Mary Queen of Scots. It was an unfortunate match, and ere long gave rise first to coolness, then to open quarrel, and finally to deadly hate, which the murder of Rizzio, to which Darnley was a party, only increased. Mary affected, however, to be reconciled to him, but could not long conceal her contempt for the handsome imbecile. After the birth of a son, subsequently James VI., Darnley was seized at Glasgow with smallpox, from which he had barely recovered when Mary visited him, and had him conveyed to an isolated house called Kirk of Field, close to the Edinburgh city walls. This dwelling, which belonged to a retainer of Bothwell's, the rapidly rising favourite, was blown into the air with gunpowder (10th February, 1567). The dead bodies of the king and his page were found in a field at a distance of 80 yards from the house, quite free from any mark which such an explosion would cause. Strong circumstantial evidence points to Bothwell as the murderer, and to Mary as an accomplice in the crime.

Darrang, an administrative district of Hindustan, forming a portion of the upper valley of the Brahmaputra, in the prov. of Assam; area, 3418 sq. m.; pop. 273,333. Virgin forests cover a large portion of the region.

Darters, or SNAKE-BIRDS, a genus (*Plotus*) of web-footed birds of the pelican tribe, found near the eastern coasts of the tropical parts of America, and on the western coast of tropical Africa, as well as in Australia. The birds perch on trees by the sides of lakes, lagoons, and rivers, and after hovering over the water suddenly dart at their finny prey with unerring aim (hence the name). From the serpent-like form of their head and neck, the head being scarcely thicker than the neck, they are called snake-birds.

Dart'ford, a town, England, Kent, on the Darent, 15 miles south-east of London. On the river are numerous paper, corn, and oil mills, a large foundry, and an extensive gunpowder manufactory, &c. Dartford was the first place in Britain where a paper-mill was erected. Wat Tyler was a native of this place, and the insurrection known by his name broke out at Dartford (1377). Pop. 1891, 11,962.

Dartmoor', an extensive upland tract in England, in the western part of Devonshire, often called the *Forest of Dartmoor*, and belonging to the Duchy of Cornwall; reaching from Brent s., to Oakhampton n., 22 miles, with a breadth of about 20 miles, and occupying from 130,000 to 150,000 acres. Cattle and sheep are fed on the coarse grass during the summer months. Several of the rugged granite hills (here called *tors*) are of considerable height, Yes Tor rising 2050 feet above the plain. Dartmoor prison, built in 1809 as a state-prison, is now a convict depôt.

Dart'mouth, a municipal borough and seaport of England, county of Devon, situated near the entrance of the river Dart into the British Channel, 30 miles south from Exeter. The harbour is safe and commodious, and the port is much resorted to by ocean steamers for coaling purposes. Pop. 1891, 6038.

Daru, PIERRE ANTOINE NOEL MATTHIEU BRUNO, COUNT, French statesman and author, born at Montpellier 1767, died 1829. He favoured the revolution, but was imprisoned during the reign of terror, when he translated the odes and epistles of Horace into French verse. Napoleon discovered his abilities and rewarded him by various official appointments of trust. In the campaigns against Austria and Prussia (1806-09) he served with ability as a diplomatist and financier. He became chief minister of state in 1811, and was called to the chamber of peers in 1818. He latterly devoted himself exclusively to letters. His chief works are his History of the Venetian Republic, Life of Sully, History of Bretagne, &c.

Darwar. See *Dharwar*.

Dar'wen, OVER, a municipal borough of Lancashire, England, 3½ miles south of Blackburn. Until about the middle of this century Over Darwen was an insignificant village; now it is a populous and thriving town. The staple manufacture is cotton; other manufactures are paper, iron castings, earthenware, &c. Pop. 1891, 34,192.

Dar'win, CHARLES ROBERT, English naturalist, born at Shrewsbury in 1809, died at Down, near Beckenham in Kent 1882; was the son of Dr. Robert Darwin and grandson of Dr. Erasmus Darwin. He was

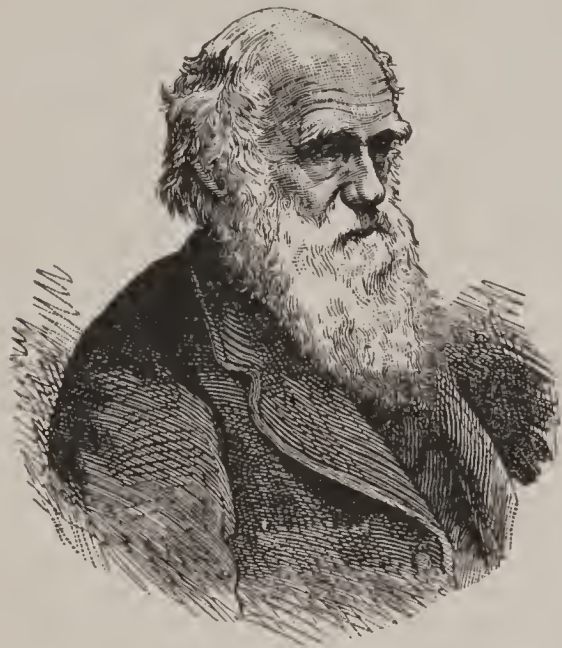

Charles Darwin.

educated at Shrewsbury School, and at the universities of Edinburgh and Cambridge. He early devoted himself to the study of natural history, and in 1831 he was appointed naturalist to the surveying voyage of H.M.S. *Beagle*, commanded by Captain (afterwards Admiral) Fitzroy. The vessel sailed in Dec. 1831, and did not return till Oct. 1836, after having circumnavigated the globe. Mr. Darwin came home with rich stores of knowledge, part of which he soon gave to the public in various works. In 1839 he married his cousin Emma Wedgwood, and henceforth spent the life of a quiet country gentleman, engrossed in scientific pursuits—experimenting, observing, recording, reflecting, and generalizing. In 1839 he published his *Journal of Researches during a Voyage round the World*; in 1842 *Structure and Distribution of Coral Reefs*; in 1844 *Geological Observations on Volcanic Islands, &c.*; in 1846 *Geological Observations in South America*; in 1851 and 1854 his *Monograph of the Cirrhipedia*, and soon after the *Fossil Lepadridæ and Balænidæ of Great Britain*. In 1859 his name attained its great celebrity by the publication of *The Origin of Species by Means of Natural Selection*. This work, scouted and derided though it was at first in certain quarters, may be said to have worked nothing

less than a revolution in biological science. In it for the first time was given a full exposition of the theory of evolution as applied to plants and animals, the origin of species being explained on the hypothesis of natural selection. The rest of his works are largely based on the material he had accumulated for the elaboration of this great theory. The principal are a treatise on the Fertilization of Orchids (1862); *Domesticated Animals and Cultivated Plants*; or *The Principle of Variation, &c., under Domestication* (1867); *Descent of Man and Variation in Relation to Sex* (1871); *The Expression of the Emotions in Man and Animals* (1872); *Movements and Habits of Climbing Plants* (2d ed. 1875); *Insectivorous Plants* (1875); *Cross and Self Fertilisation* (1876); *The Power of Movement in Plants* (1880); *The Formation of Vegetable Mould* (1881); the last containing a vast amount of information in regard to the common earth-worm. Mr. Darwin was buried in Westminster Abbey.—His son GEORGE HOWARD, born 1845, has distinguished himself both in mathematics and in physics; was second wrangler at Cambridge in 1868, and in 1883 was elected Plumian professor of astronomy in the same university.

Darwin, ERASMUS, M.D., English physician and poet, was born in 1731. He was educated at Cambridge and Edinburgh; practised as a physician in Lichfield till 1781, when he removed to Derby, near which he died in 1802. His name is chiefly known from his poem of the *Botanic Garden*, which first appeared in 1789 and 1792. The fame it acquired was splendid but very transient, and it has since almost sunk into oblivion. In 1794–96 Dr. Darwin published *Zoonomia, or the Laws of Organic Life*; in 1799 *Phytologia, or the Philosophy of Agriculture and Gardening*. The *Temple of Nature* appeared posthumously in 1803. Charles Darwin was his grandson.

Dar'winism, the views, especially regarding the origin and development of animals and plants, expressed in detail and advocated with much earnestness in the works of Charles Darwin. See *Evolution, Natural Selection, &c.*

Dass, PETTER, Norwegian poet, of Scottish extraction, born 1647, died 1708. He is known as the 'father of Norwegian poetry,' and his principal poem, *The Trumpet of Northland*, is one of the most favourite national poems.

Das'yure, **DASYURUS**, the brush-tailed opossums, a genus of plantigrade marsupials found in Australia and Tasmania, and so named in contrast to the opossums of the New World (*Didelphys*), which have naked tails somewhat like rats. The ursine dasyure (*Dasyūrus ursinus*) of Tasmania is about the size of a badger, but of a sturdier form, of a dull black colour, carnivorous, and of so savage a temper as to have gained for itself the alternative name of *Diabolus ursinus*, or Tasmanian devil. Formerly it was most destructive to flocks and poultry-yards, but is now in the inhabited districts nearly extirpated. The various species of the genus have much the same nature and habits as the European polecat.

Data'ria, the papal office of the chancery at Rome, from which all bulls are issued.

Date (Latin, *datum*, given), that addition to a writing which specifies the year, month, and day when, and usually the place where, it was given or executed; also the time when any event happened, when anything was transacted, or when anything is to be done.

Date, the fruit of the date-palm or the tree itself, the *Phoenix dactylifera*. The

Next to the cocoa-nut tree the date is unquestionably the most interesting and useful of the palm tribe. Its stem shoots up to the height of 50 or 60 feet without branch or division, and of nearly the same thickness throughout its length. From the summit it throws out a magnificent crown of large feather-shaped leaves, and a number of spadices, each of which in the female plant bears a bunch of from 180 to 200 dates, each bunch weighing from 20 to 25 lbs. The fruit is eaten fresh or dried. Cakes of dates pounded and kneaded together are the food of the Arabs who traverse the deserts. A liquor resembling wine is made from dates by fermentation. Persia, Palestine, Arabia, and the north of Africa are best adapted for the culture of the date-tree, and its fruit is in these countries an important article of food.

Date-plum, the name given to several species of *Diospyros*, a genus of trees of the ebony family. The European date-plum is the *D. Lotus*, a low-growing tree, native of the south of Europe. It produces a small fruit, the supposed lotus of the ancients. The American date-plum, or persimmon (*D. virginiana*), attains a height of 50 or 60 feet; the fruit is nearly round, about an inch in diameter, is very austere, but edible after being frosted. The Chinese date-plum (*D. Kaki*) is cultivated for the sake of its fruit, which is about the size of a small apple, and is made into a preserve.

Dath'olite, the siliceous borate of lime, a mineral of a white colour of various shades found in Scotland and on the Continent; also near Lake Superior, U. S., where it is used in the manufacture of boracic acid.

Datia (*dat'i-a*), a native state in Bundelkhand, Hindustan, under the Central India Agency. Area, 836 sq. m.; pop. 182,598.—**DATIA**, the chief town of the state, is situated 125 miles S.E. of Agra, and contains a large number of handsome houses, the residences of the local aristocracy. Pop. 28,346.

Datis'cin, a substance yielded by the bastard hemp, *Datisca cannabina*, a herbaceous dioecious perennial, a native of the south of Europe, where it is used as a substitute for Peruvian bark, and for making cordage. Datiscin ($C_{21}H_{22}O_{12}$) is extracted from the leaves, and is used as a yellow dye.

Da'tive (L. *dativus*, from *dare*, to give), in grammar, a term applied to the case of nouns which usually follows verbs or other parts of speech that express giving, or some act directed to the object, generally indicated in English by *to* or *for*.



Date-palm (*Phoenix dactylifera*).

fruit is used extensively as an article of food by the natives of Northern Africa and of some countries of Asia. It consists of an external pericarp, separable into three portions, and covering a seed which is hard and horny in consequence of the nature of the albumen in which the embryo plant is buried.

Datu'ra, a genus of plants, order Solanaceæ, with large trumpet-shaped flowers. There are several species, all having poisonous properties and a disagreeable odour.

D. Stramonium is the thorn-apple, possessing strong narcotic properties, and sometimes employed as a remedy for neuralgia, convulsions, &c. The dried leaves of *D. Stramonium*, and *D. Tatula*, an American species, are smoked as a cure for asthma.



Thorn-apple (*Datura Stramonium*).—1, Root. 2, Seed-vessel cut across.

Dat'urine, a poisonous alkaloid found in the thorn-apple (*Datura Stramonium*), said to be identical with atropine, the alkaloid from deadly nightshade.

Daubenton (dō-bān-tōn), or D'AUBENTON, LOUIS JEAN MARIE, a French naturalist and physician, born 1716, died 1800. He studied medicine at Paris, and in 1742 began to assist Buffon in the preparation of his great work on natural history, the anatomical articles of which were prepared by him. In 1745 he was appointed curator and demonstrator of the cabinet of natural history in Paris, of which he had charge for nearly fifty years. He became professor of natural history in the College of France in 1778. Among his publications are: Instructions to Shepherds, A Methodical View of Minerals, &c., and he contributed many scientific articles to the first Encyclopédie.

Dau'beny, CHARLES GILES BRIDLE, M.D., botanist, &c., born 1795, died 1867. For many years he was professor of chemistry, botany, and rural economy at Oxford, and wrote several esteemed scientific works.

D'Aubigné. See *Merle D'Aubigné*.

Daucus, a genus of umbelliferous plants, the most important of which is the carrot.

Daudet (dō-dā), ALPHONSE, French novelist, born at Nîmes 1840. He settled in Paris in 1857, and wrote poems, essays, plays, &c., without much success, till he discovered his powers as a novelist, when he speedily rose to the highest rank. His more celebrated works are *Fromout jeune et Risler Aîné* (1874); *Jack* (1876); *Le Nabab* (1877); *Les Rois en Exil* (1879);

Numa Roumestan (1881); *L'Evangeliste* (1882); *Sappho* (1884); *Tartarin en les Alpes* (1886), a sequel to *Les Aventures Prodigieuses de Tartarin de Tarascon*, published in 1874; *Trente Ans à Paris* (autobiographical), 1888; and *L'Immortel* (1888). All his most important works have been translated into English.—His elder brother, ERNEST DAUDET (born 1837), has also distinguished himself as a novelist and one of the best-known political writers of the French republican party.

Daud'nagar, a town in Gayá district, Bengal; has manufactures of cloth, carpets, and blankets; and a river trade with Patna. In the vicinity is a fine temple. Pop. 9870.

Daulatábád, a town of India, in the Nizam's Dominions (Haidarabad), Deccan; 170 miles N.E. of Bombay; the fortress, also known by the name of *Deogiri*, was from remote antiquity the stronghold of the rulers of the Deccan. Pop. 1243.

Daun (doun), LEOPOLD JOSEPH MARIA, COUNT VON, an Austrian general, was born in 1705 and died in 1766. He served in the Turkish war in 1710, as major-general in Italy in 1734, and distinguished himself at the battle of Krozka in 1737, and the capture of Dingelfingen in 1740. In 1748, after serving against the French in the Netherlands, he was made knight of the Golden Fleece. His skilful passage of the Rhine, and his marriage with the Countess of Fux, a favourite of Maria Theresa, procured for him the post of master-general of the ordnance, and in 1757 that of general field-marshal. That same year he defeated Frederick the Great at Kollin, and soon after took Breslau. In 1758 he again defeated Frederick at Hochkirch; but he was at last thoroughly defeated by Frederick at Torgau in 1759. He afterwards became president of the aulic council.

Dau'phin, the title of the eldest son of the King of France prior to the revolution of 1830, said to be derived from the dolphin, the crest of the lords of Dauphiny. The name was assumed towards the middle of the 9th century by the lord of Dauphiny, which province was bequeathed by Humbert II. to the King of France in 1349, on condition that the heir of the throne should bear the title of Dauphin of Viennois.

Dau'phiny (*Dauphiné*), one of the ancient provinces of France, which comprised the modern departments of the Isère, the Hautes Alpes, and part of that of the Drôme. The capital of the whole was Grenoble.

Dauw (da'ū), or **PEECHI** (*Equus Burcheli*), a species of zebra which inhabits the plains of Southern Africa, particularly to the north of the Orange River. Its general colour is a pale brown, with grayish-white on the abdomen and inner parts of the limbs. Its head, neck, and body, and the upper parts of its limbs are striped like the zebra, but the stripes are not so dark in colour. The Dutch colonists call it *Bonte-quagga*.

Dav'enant, **SIR WILLIAM**, English poet and dramatist, born at Oxford 1605, died 1688. His father kept the Crown Inn, a house at which Shakspeare used to stop on his journeys between London and Stratford. He was early introduced into court life through his service with the Duchess of Richmond and Lord Brooke; and having produced several plays and court masques, he succeeded Ben Jonson in the laureateship (1637). During the civil war he fought on the royal side, was made a lieutenant-general, and received the honour of knighthood. On the decline of the royal cause he retired to France; but attempting to sail for Virginia, his ship was captured, and he escaped death through the good offices of John Milton, a kindness he was able to repay after the Restoration. Under Charles II. Davenant flourished in the dramatic world. His works consist of dramas, masques, addresses, and the epic *Gondibert*, which was never finished; but he is remembered chiefly by the travesty of Shakspeare's *Tempest*, made in conjunction with Dryden. He was buried in Westminster Abbey.

Dav'enport, a city of Iowa, United States, situate at the foot of the upper rapids of the Mississippi, near Rock Island. Woollen goods, agricultural implements and machines, pottery, carriages, engines, and machinery are among the manufactures. Pop. 1890, 26,872.

Dav'entry, or **DAINTREE**, a market town, England, county of and 11 miles w. by n. of Northampton; has extensive manufactures of whips and shoes. Pop. 3859.

David, King of Israel, the youngest son of Jesse, a citizen of Bethlehem, and descended through Boaz from the ancient princes of Judah. The life of David is recorded in the first and second books of Samuel and the first book of Chronicles. The book of Psalms, a large portion of which has been attributed to him (see *Psalms*), also contains frequent allusions to incidents in his life. He reigned from 1055 B.C. to 1015 B.C. according to the usual chronology, but

recent investigations put the dates of David's reign from 30 to 50 years later. Under David the empire of the Israelites rose to the height of its power, and his reign has always been looked on by the Jews as the golden age of their nation's history.

David I., King of Scotland, son of Malcolm Canmore; born about 1080; succeeded his brother Alexander I. in 1124; died 1153. He was the first to introduce feudal institutions and ideas into his native land. He twice invaded England to support his niece Matilda against Stephen, her rival claimant for the English crown, during one of his incursions being defeated at the Battle of the Standard (1138). He died at Carlisle, and was succeeded by his grandson Malcolm. He acquired a considerable reputation for sanctity. While yet Prince of Cumbria he had begun the establishment of the Glasgow bishopric. He adjusted the bishoprics of Dunkeld, Moray, Aberdeen, Ross, Caithness, Erchin, Dunblane, and Galloway. Among the religious houses for regulars which date from his reign are Holyrood, Melrose, Jedburgh, Kelso, Dryburgh, Newbattle, &c. His services to the church procured for him the popular title of saint, but the endowments so taxed the royal domains and possessions that James VI. bitterly characterized him as 'ane sair sanct for the crown.'

David II., King of Scotland, son of Robert Bruce, born 1322; succeeded to the throne 1329; died 1370. On the death of his father he was acknowledged by the great part of the nation. Edward Baliol, however, the son of John Baliol, formed a party for the purpose of supporting his pretensions to the crown; he was backed by Edward III. of England. Battles were frequent, and at first Baliol was successful; but eventually David succeeded in driving him from Scotland. Still, however, the war was carried on with England with increasing rancour, till at length David was made prisoner at the battle of Neville's Cross (1346). After being detained in captivity for eleven years he was ransomed for 100,000 merks. The remainder of his reign was occupied in disputes with his parliament.

David, **FÉLICIEN-CÉSAR**, French musician and composer, born at Cadenet (Vaucluse) 1810, died 1876. He entered the Paris Conservatoire in 1830, and became an ardent disciple of St. Simon, Infantin, and other social speculators. In 1832, with a few companions, he went to the East in

order to realize his dreams of a perfect life, but returned disappointed in 1835. He then published his *Mémoires Orientales*, and soon after his most successful work, *Le Désert*. Other works are: *Moïse sur le Sinai*, *Christophe Colomb*, *Le Paradis*, *Le Perle du Brésil*, *Herculaneum*, and *Lalla Rookh*.

David, JACQUES LOUIS, the founder of the modern French school of painting, born at Paris 1748, died at Brussels 1825. He went to Rome in 1774, and passed several years there painting several important pictures. A second visit produced the *Horatii*, one of his masterpieces. In 1787 he produced *The Death of Socrates*, in 1788 *Paris and Helen*, and in 1789 *Brutus*. In the revolution he was a violent Jacobin, and wholly devoted to Robespierre. Several of the scenes of the revolution supplied subjects for his brush. What is considered his masterpiece, *The Rape of the Sabines*, was painted in 1799. He was appointed first painter to Napoleon about 1804; and after the second restoration of Louis XVIII. he was included in the decree which banished all regicides from France, when he retired to Brussels.

David, PIERRE JEAN, a French sculptor, born at Angers in 1789 (hence commonly called *David d'Angers*), died 1856. He went when very young to Paris, became the pupil of J. L. David, and in 1809 a prize obtained from the Academy enabled him to pursue his studies at Rome, where he formed a friendship with Canova. On his return to Paris he laid the foundation of his fame by a colossal statue of the great Condé in marble. He visited Germany twice, in 1828 and 1834, and executed busts of Goethe for Weimar, of Schelling for Munich, of Tieck for Dresden, of Rauch and Humboldt for Berlin. In 1831 he began the magnificent sculptures of the Pantheon, his most important work, which he finished in 1837. He executed a great number of medallions, busts, and statues of celebrated persons of all countries, among whom we may mention Walter Scott, Canning, Washington, Lafayette, Guttenberg, Cuvier, Victor Hugo, Béranger, Paganini, and Madame de Staël.

David, SAINT, patron of Wales, Archbishop of Caerleon, and afterwards of Menevia, now St. David's, where he died about 601. He was celebrated for his piety, and many legends are told of his miraculous powers. His writings are no longer extant. His life was written by Ricemarch, bishop of St. David's in the 11th century.

David's, St., decayed episcopal city, Wales, county Pembroke, near the promontory of St David's Head, once the metropolitan see of Wales. Within a space of 1200 yards in circuit are the cathedral, chiefly of the 12th century, with a finely-decorated rood-loft, the episcopal palace, the ruins of St. Mary's College, and other ecclesiastical edifices, chiefly ruinous. Pop. of township, 2131.

Da'vies, SIR JOHN, English poet and lawyer, born 1570, died 1626. In 1603 he was appointed solicitor-general for Ireland, and soon after attorney-general. He was knighted in 1607, returned to the English parliament in 1621, and obtained the dignity of lord chief-justice in 1626. He wrote *Orchestra*; *Hymns to Astrea*; *Nosce Teipsum*, a metaphysical poem and his best-known work; he is also the author of a work on the political state of Ireland.

Da'vila, ENRICO CATERINO, an Italian historian, born near Padua in 1576, died 1631. Brought up in France, he for a time served with distinction in the French army. In 1599 he entered the Venetian service.

Davis, HENRY WINTER, statesman, was born in Annapolis, Md., Aug. 17, 1817. As member of Congress was a brilliant orator. Although representing a slave State he was unfaltering in fidelity to the Union and a strenuous advocate of emancipation, and as early as 1865 favored negro suffrage. He died Dec. 30, 1865.

Davis, JEFFERSON, president of the Confederate States of America during the civil



Jefferson Davis.

war; born in Kentucky 1808. He was trained at West Point Military Academy, and from 1828 to 1835 saw a good deal of service on the frontier. At the latter date

he became a cotton planter in the state of Mississippi. He was elected to Congress in 1845, but at the commencement of the Mexican war he left Congress and engaged actively in the contest. He entered the Senate in 1847, and held various posts in the government, upholding the policy of the slave states and the doctrine of slave rights. On the outbreak of the civil war he was chosen president of the Southern States, was taken prisoner after the fall of Richmond, imprisoned for two years in Fortress Monroe, and set at liberty by the general amnesty of 1868. He has since written a history of the war. He died in 1889, at New Orleans.

Davis, or **DAVYS**, **JOHN**, an English navigator, born at Sandridge, in Devonshire about 1550. In 1585-87 he conducted three expeditions for the discovery of the north-west passage. In the first he coasted round the south of Greenland and sailed across the strait that now bears his name into Cumberland Gulf, and in the third he sailed north through Davis Strait into Baffin's Bay. He also accompanied the expedition of Cavendish to the Pacific in 1591-93, and made several voyages to the East Indies. In 1605 Davis was killed by Japanese pirates in the Indian seas. He wrote *Seamen's Secrets* (a work on navigation), and the *World's Hydrographical Description*.

Da'vison, **WILLIAM**, a statesman in the reign of Queen Elizabeth, of Scottish extraction. After being employed in several important diplomatic missions to Holland and Scotland, he became secretary of state to Queen Elizabeth in 1586. He was made the scapegoat of the other ministers for his excess of zeal in despatching the warrant for the execution of Mary Queen of Scots (1587). He was brought to trial, heavily fined and imprisoned, and died in 1608 without regaining favour.

Davis' Strait, a narrow sea which separates Greenland from Baffin's Land, and unites Baffin's Bay with the Atlantic Ocean; lat. 60° to 70° N.

Da'vits, two projecting pieces of wood or iron on the side or stern of a vessel, used for suspending or lowering and hoisting the boats by means of sheave and pulley. They are fixed so as to admit of being shipped and unshipped at pleasure.

Davos (dä-vōs'), an elevated valley (over 5000 ft.) of Switzerland, canton Grisons, containing several villages; a winter resort of persons suffering from chest diseases.

Davout, or **DAVOUST** (dä-vö), **LOUIS NICO-**

LAS, Duke of Auerstädt and Prince of Eckmühl, marshal and peer of France, born in 1770 at Annoux, in Burgundy; died 1823. He entered the army at the age of seventeen; served with distinction under Dumas, and at the passage of the Rhine, in 1797. He went with Bonaparte to Egypt in 1798, and commanded the cavalry of the army of Italy in 1800. He received a marshal's baton in 1804, led the right wing at Austerlitz in 1805, and defeated the Prussians at Auerstädt in 1806. He shared the glory of Eylau, Eckmühl, and Wagram; was made governor of Hamburg; took part in the Russian campaign of 1812, and was wounded at Borodino. During the Hundred Days (1815) he was Napoleon's minister of war, and after Waterloo was appointed by the provisional government general-in-chief of the French armies. In 1819 he was a member of the Chamber of Peers.

Da'vy, **SIR HUMPHRY**, **BART.**, distinguished English chemist, was born at Penzance, 1778, died at Geneva 1829. After having received the rudiments of a classical edu-



Sir Humphry Davy.

cation he was placed with a surgeon and apothecary, and early developed a taste for scientific experiments. So successful was he in his studies that he was appointed professor of chemistry in the Royal Institution at the age of twenty-four. In 1803 he was chosen a member of the Royal Society. His discoveries with the galvanic battery, his decomposition of the earths and alkalies and ascertaining their metallic bases, his demonstration of the simple nature of the oxymuriatic acid (to which he gave the name of *chlorine*), &c., obtained him an

extensive reputation; and in 1810 he received the prize of the French Institute. In 1814 he was elected a corresponding member of that body. Having been elected professor of chemistry to the Board of Agriculture he delivered lectures on agricultural chemistry during ten successive years. The numerous accidents arising from fire-damp in mines led him to enter upon a series of experiments on the nature of the explosive gas, the result of which was the invention of his safety-lamp. He was knighted in 1812, and created a baronet in 1818. In 1820 he succeeded Sir J. Banks as president of the Royal Society, and at the time of his death he was a member of most of the scientific societies of Europe. His health had been failing for some time, and in his last year he had gone abroad to recruit. His most important works are: *Philosophical Researches*; *Elements of Agricultural Chemistry*; *Electro-Chemical Researches*; *Elements of Chemical Philosophy*; *Researches on the Oxymuriatic Acid*; *On Fire damp*. He also contributed some valuable papers to the *Philosophical Transactions*, and was author of *Salmonia, or Days of Fly-fishing*; and *Consolations in Travel, or the Last Days of a Philosopher*. •

Davy-lamp. See *Safety-lamp*.

Da'vyum (after Sir H. *Davy*), a metal of the platinum group discovered in 1877. It is a hard silvery metal, slightly ductile, extremely infusible, and has a density of 9.385 at 25° C.

Dawes, HENRY L., U. S. Senator from Massachusetts, was born in Cummington, Mass., Oct. 30, 1816. He graduated at Yale College and studied law. After serving as member of House for seven consecutive terms, in 1874 elected U. S. Senator; re-elected 1881 and 1887. He is one of the oldest and most respected Senators.

Dawson, HENRY, English landscape-painter, born 1811, died 1878. In early life he was a worker in a Nottingham lace-factory, but this occupation he gave up for art in 1835. After struggling some time at Nottingham he removed to Liverpool in 1844, and thence to Croydon in 1850, and latterly he resided at Chiswick. It was long before his abilities were fully recognized, and his pictures began to fetch high prices only a little before his death. Among the best of them are *Wooden Walls of Old England*, *London from Greenwich Hill*, *Houses of Parliament*, *The Rainbow*, *Rainbow at Sea*, *The Pool below London Bridge*.

Dawson, SIR JOHN WILLIAM, Canadian geologist, born at Picton, Nova Scotia, in 1820. He was educated at Picton and Edinburgh University, and early turned his attention to geology, having published papers on the subject when not much over twenty. He accompanied Sir Charles Lyell when examining the geology of Nova Scotia in 1842. In 1850 he became superintendent of education for Nova Scotia, and in 1855 principal and professor of natural history in M'Gill College, Montreal, in which position, as well as in that of vice-chancellor, and latterly principal of the university, his services in the cause of education have been very marked. He became a member of the Royal Society (London) in 1862, was knighted in 1885, and was president of the British Association in 1886 during its meeting at Birmingham. His published works include *Acadian Geology*; *The Story of the Earth and Man*; *Science and the Bible*; *The Dawn of Life*; *The Chain of Life*; &c.

Dax, a town and watering-place of South-western France, dep. Landes, on the left bank of the Adour, 25 miles N.E. of Bayonne. The chief attraction of the place is its thermal springs, which have temperatures varying from 86° to 166° Fahr., were much frequented by the Romans, and are still in great repute for the cure of rheumatic and similar complaints. Pop. 8927.

Day, either the interval of time during which the sun is continuously above the horizon, or the time occupied by a revolution of the earth on its axis, embracing this interval (the period of light) as well as the interval of darkness. The day in the latter sense may be measured in more than one way. If we measure it by the apparent movement of the stars, caused by the rotation of the earth on its axis, we must call day the period between the time when a star is on the meridian and when it again returns to the meridian: this is a *sidereal day*. It is uniformly equal to 23 hours, 56 minutes, 4.098 seconds. But more important than this is the *solar day*, or the interval between two passages of the sun across the meridian of any place. The latter is about 4 minutes longer than the former, owing to the revolution of the earth round the sun, and it is not of uniform length, owing to the varying speed at which the earth moves in its orbit and to the obliquity of the ecliptic. For convenience an average of the solar day is taken, and this gives us the *mean solar or civil day* of 24 hours, the difference

DAY.

between which and the actual solar day at any time is the *equation of time*.

The length of the days and nights at any place varies with the latitude and season of the year, owing to the inclination of the earth's axis. In the first place, the days and nights are equal (twelve hours each) all over the world on the 21st of March and the 21st of September, which dates are called the *vernal* (spring) and *autumnal equinoxes* (Lat. *æquus*, equal; *nox*, night). Again, the days and nights are always of equal length at the equator, which, for this reason, is sometimes called the *equinoctial line*. With these exceptions, we find the difference between the duration of the day and the night varying more and more as we recede from the equator. This will be easily understood from a consideration of the accompanying fig., which represents the position of the earth at the northern summer solstice. Let SA, S'D, S''B represent the sun's rays, then the

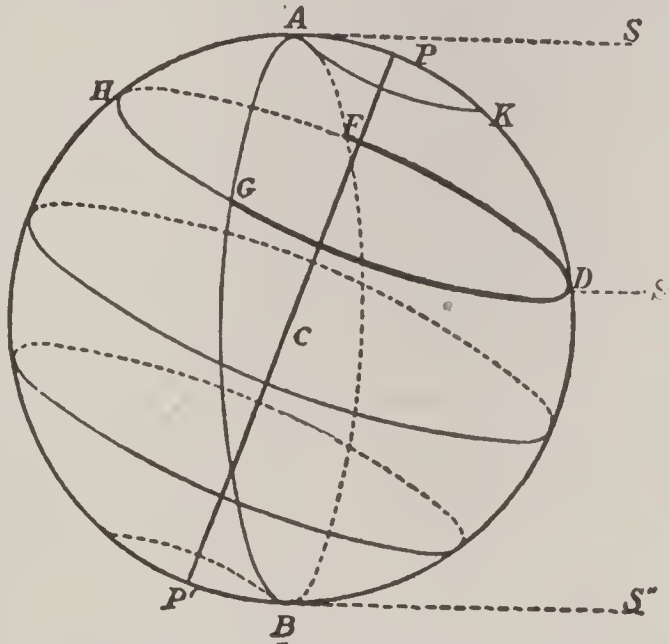

Diagram to illustrate the Differences in the Length of Day and Night.

vertical circle AFBG will be the *circle of illumination*, that is, the line which separates the illuminated and dark hemispheres of the earth. Consider a place F. As the earth turns round it would describe a circle FDGH, the greater part of which, FDG, is performed in the sunlight, and the smaller part, GHF, in the dark. In other words, the day for the place F would be longer than its night. It will be also seen that for any place within the Arctic circle AK the sun does not set, while in the Antarctic circle the sun never rises so long as the earth is in this position. At the northern winter solstice the reverse of all this is the case—the Arctic circle never comes into the light area, and places within the Antarctic circle never enter into the dark. From this it will be seen that at both poles the year consists of one day of six months' duration, and one night of the same length.

The Babylonians began the day at sunrise; the Jews at sunset; the Egyptians and Romans at midnight, as do most modern

peoples. The civil day in most countries is divided into two portions of twelve hours each. The abbreviations P.M. and A.M. (the first signifying *post meridiem*, Latin for *afternoon*; the latter *ante meridiem*, *forenoon*) are requisite, in consequence of this division of the day. The Italians in some places reckon the day from sunset to sunset, and enumerate the hours up to twenty-four; the Chinese divide it into twelve parts of two hours each. For astronomical purposes the day is divided into twenty-four

hours instead of two parts of twelve hours. Formerly it began at noon, but since 1st Jan. 1885, the day of twenty-four hours begins at midnight at Greenwich Observatory; and this reckoning is now generally adopted for astronomical purposes elsewhere than at Greenwich. The Greenwich day practically determines the date for all the world. At mid-day at Greenwich the date (day of the week and month) is everywhere the

same, though there are all possible differences in naming the hour of the day. But mid-day at Greenwich is the only instant at which we ever have the same date all over the world. The meridian of midnight, which is then at 180° E. or W., goes on revolving, gradually bringing a new date to every place to the west of that line, but obviously not bringing that new date to the places immediately to the east of that line till twenty-four hours after. From this it follows that whereas places on the one side of the globe never have a different date except when midnight lies between them, places on the opposite side of the globe, and on different sides of the meridian of 180° E. or W., never have the same date except when midnight lies between them. The actual difference of time between Wellington in New Zealand and Honolulu in the Sandwich Islands is only about 2 hours; yet a person at Wellington may date a letter 9 o'clock A.M. 26th June, while another writing at the same instant at Honolulu dates his 11 o'clock A.M. 25th June.

Day, THOMAS, an ingenious writer, of a benevolent, independent, but eccentric spirit, was born at London in 1748, killed by a fall from a horse 1789. His father, who was a collector of the customs, died whilst he was an infant, leaving him a considerable fortune. He was educated at the Charter House and at Oxford. In 1765 he was called to the bar. He renounced most of the indulgences of a man of fortune, that he might bestow his superfluities upon those who wanted necessaries; and he also expressed a great contempt for forms and artificial restraint of all kinds. He wrote, in prose and verse, on various subjects, but the History of Sandford and Merton is the only work by which his name is perpetuated.

Day-book, a journal of accounts; a book in which are recorded the debts and credits or accounts of the day. See *Book-keeping*.

Dayfly, the popular name of those neuropterous insects which belong to the genus *Ephemera*. They are so called because, though they may exist in the larval and pupal state for several years, in their perfect form they exist only from a few hours to a few days, taking no food, but only propagating their species and then dying.

Day-lily, the popular name for a genus of lilies (*Heemerocallis*), natives of temperate Asia and Eastern Europe, two species of which (*H. flava* and *H. fulva*) are grown in gardens. They have long radical leaves, and a branched few-flowered scape, with large handsome blossoms, the segments of which are united into a tube.

Daysman, in English law, an arbitrator or elected judge. This term is antiquated. It occurs in the book of Job, ch. ix. 33.

Days of Grace are days allowed for the payment of a promissory note or bill of exchange after it becomes due. The time varies in different countries.

Dayton, a town, United States, Ohio, capital of Montgomery county, at the confluence of the Mad and Great Miami rivers, 52 miles N.E. of Cincinnati. It is a place of great industrial activity, a centre of railway communication, and in the variety and extent of its manufactures it stands in the front rank of western towns of its size. The national home for disabled soldiers and sailors is situated here. Pop. 61, 220.

Deacon, ecclesiastically, a person in the lowest degree of holy orders. The office of deacon was instituted by the apostles, and seven persons were chosen at first to

serve at the feasts of Christians, and distribute bread and wine to the communicants, and to minister to the wants of the poor. In the Roman Catholic Church the deacon is the chief minister at the altar. He assists the priest in the celebration of mass, and on certain conditions can preach and baptize. In the Church of England the deacon is the lowest of the three orders of priesthood, these being bishops, priests, and deacons. The deacon may perform all the ordinary offices of the Christian priesthood except consecrating the elements at the administration of the Lord's Supper, and pronouncing the absolution. In Presbyterian churches the deacon's office is to attend to the secular interests, and in Independent churches it is the same, with the addition that he has to distribute the bread and wine to the communicants.

Deacon, in Scotland, the president of an incorporated trade, who is the chairman of its meetings and signs its records. Before the passing of the Burgh Reform Act the deacons of the crafts, or incorporated trades, in royal burghs, formed a constituent part of the town-council, and were understood to represent the trades as distinguished from the merchants and guild brethren. The deacon-convenor of the trades in Edinburgh and Glasgow still continues to be a constituent member of the town-council.

Deaconess, (1) a female deacon in the primitive church; (2) the term for a kind of quasi sister of mercy among certain Continental and other Protestants.

Dead-eyes, in ships, round flattish wooden blocks, encircled by a rope or an iron band, used to extend the shrouds and stays, and for other purposes.

Dead-letter, a letter which lies for a certain period uncalled for at the post-office, or one which cannot be delivered from defect of address, and which is sent to the general post-office to be opened and returned to the writer.—*Dead-letter office*, a department of the general post-office where dead-letters are examined and disposed of.

Dead-lights are strong wooden or metal shutters fitted on the outside of the cabin windows of a vessel, so as to close them tightly in bad weather.

Deadly Nightshade. See *Belladonna*.

Dead Men's Fingers. See *Alcyonium*.

Dead-nettle, the common name of the species of plants of the genus *Lamium*, nat. order Labiatae, from the resemblance of their leaves to those of the nettle, though they

DEAD RECKONING — DEAF AND DUMB.

have no stinging property. There are several species found in Britain (and now also in N. America), as the white dead-nettle (*L. album*), the red (*L. purpuræum*), and the yellow (*L. Galeobdolon*).

Dead Reckoning, the calculation of a ship's place at sea without any observation of the heavenly bodies. It is obtained by keeping an account of the distance which the ship has run by the log, and of her course steered by the compass, and by rectifying these data by the usual allowance for drift, leeway, &c., according to the ship's known trim.

Dead Sea (Latin, *Lacus Asphaltites*; Arabic, *Bahr Lut*, 'the Sea of Lot'), called in Scripture 'Salt Sea,' 'Sea of the Plains,' and 'East Sea,' a celebrated lake in Asiatic Turkey, near the south extremity of Palestine, in the pashalic of Damascus. The north extremity is 25 miles east of Jerusalem and 10 miles south-east of Jericho; length, north to south, about 46 miles; breadth at the widest part, 9 to 10; average, about 8½ miles. The basin or hollow in which the Dead Sea reposes forms the south termination of the great depression through which the Jordan flows, that river entering it at its north extremity. It receives several other tributaries, but has no outlet. The surface is 1312 feet below the level of the Mediterranean, and 984 ft. below Lake Tiberias, from which the Jordan issues. It lies deeply imbedded between lofty cliffs of naked limestone, its shores presenting a scene of indescribable desolation and solitude, encompassed by desert sands, and bleak, stony, salt hills. Sulphur and rock-salt, lava and pumice, abound along its shores. The water is nauseous to the taste and smell, and so buoyant that the human body will not sink in it. At about a third of its length from the north end it attains a maximum depth of 1308 feet. The southern portion is a mere lagoon, 12 ft. deep in the middle and 3 at the edges. It was long assumed that this lake did not exist before the destruction of Sodom and the other 'cities of the plain,' and that, previously to that time, the present bed of the lake was a fertile plain, in which these cities stood, and was then merely traversed by the Jordan, which, in accordance with this theory, was supposed to hold on its course to the Red Sea. This theory has been shown to be highly improbable. Eminent critics are of opinion that the cities of the plain stood on the lower part of the lake, which received

an extension when these cities were destroyed.

Deaf and Dumb, or **DEAF-MUTES**, persons both deaf and dumb, the dumbness resulting from deafness which has either existed from birth or from a very early period of life. Such persons are unable to speak simply because they have not the guidance of the sense of hearing to enable them

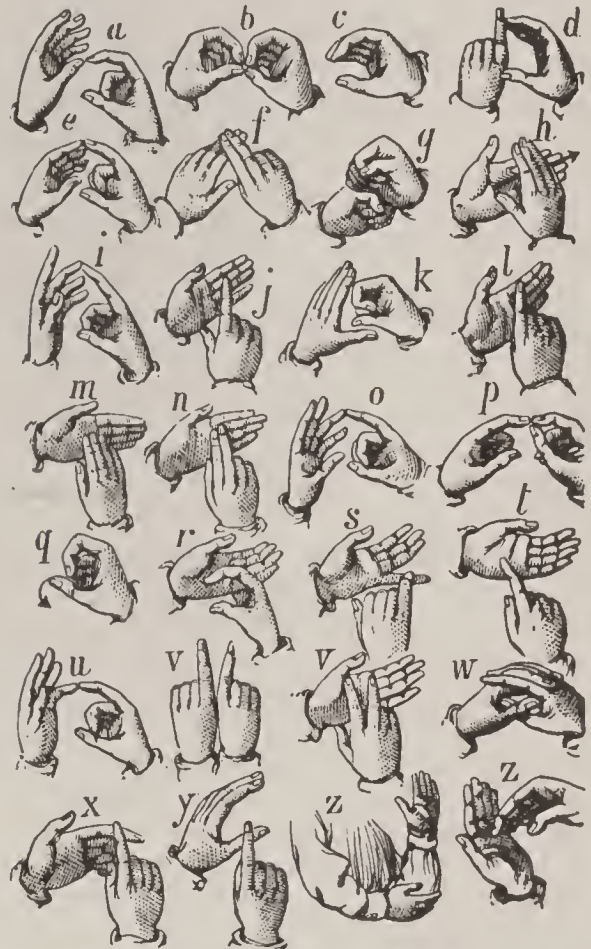

Manual Alphabet of the Deaf and Dumb.

to imitate sounds. Among the causes assigned for congenital deafness are consanguineous marriages, hereditary transmission, scrofula, certain local or climatic conditions, ill health of the mother during pregnancy, &c. Acquired or accidental deafness, which occurs at all ages, is frequently due to such diseases as smallpox, measles, typhus, paralysis, hydrocephalus, and other cerebral affections, but more particularly to scarlet fever, which is somewhat apt to leave the patient deaf owing to the inflammatory state of the throat extending to the internal ear, and thus causing suppuration and destruction of the extremely delicate parts of the auditory apparatus. In the greater proportion of deaf-mutes no defect is visible, or can be detected by anatomical examination, and no applications yet discovered appear

to be useful. The necessity of communication, and the want of words, oblige the deaf-mute to observe and imitate the actions and expressions which accompany various states of mind and of feeling, to indicate objects by their appearance and use, and persons by some peculiar mark, and to describe their actions by direct imitation. In this way he and his friends are led to form a dialect of that universal language of attitude, gesture, and expression which becomes a substitute for words in the hands of the pantomimic actor, and which adds force and clearness to the finest effusions of the orator; in other words, the natural *sign language*. This language, in its elements, is to be found among all nations, and has ever been the medium of communication between voyagers and the natives of newly discovered countries. It is employed by many savage tribes to supply the paucity of expression in their language and to communicate with other tribes. Among some of the Indians of North America it exists as a highly-organized language. Such a means of communication is after all very imperfect, however, and various more perfect systems have been devised to enable deaf-mutes to communicate with one another and with the rest of mankind, and thus to gain such an education as people in general possess. In 1648 John Bulwer published the earliest work in English on the instruction of the deaf and dumb. This was followed by Dalgarno's *Ars Signorum* (Art of Signs) in 1661, and Dr. W. D. Holder's *Elements of Speech*. Dalgarno, who was a native of Scotland, likewise published, in 1680, *Didascalocophus; or, the Deaf and Dumb Man's Tutor*, a work of considerable merit. To Dr. John Wallis, however, Savilian professor of mathematics at Oxford, is generally ascribed the merit of having been the first Englishman who succeeded in imparting instruction to deaf-mutes. In 1743 the practicability of instructing deaf-mutes was first publicly demonstrated in France by Pereira, a Spaniard, before the Academy of Sciences, which gave its testimony to the success of the method. About the same time the Abbé de l'Épée, who devoted his life and fortune to this subject, introduced a system for the instruction of the deaf and dumb, which was taught with great success in the Royal Parisian Institution, and afterwards still further developed by his pupil and successor, the Abbé Sicard. In 1779 a public institution for the education of deaf-mutes was

established at Leipzig, through the labours of Samuel Heinicke, the great upholder of the vocal or articulatory system, which is still retained at Vienna and throughout Germany. About twenty years previously Thomas Braidwood had established near Edinburgh in 1760 a deaf and dumb school on the articulating system, which was visited by Dr. Johnson during his tour in Scotland. The first public institution in Great Britain for the gratuitous education of the deaf and dumb was founded at Bermondsey in 1792 by the Rev. Messrs. Townsend and Mason. From this establishment originated the London Asylum in Kent Road, which was opened in 1807.

In the United States great advances have been made in the education of deaf-mutes, and a National Deaf-Mute College is maintained at Washington by the government. Many States have established institutions for the care and instruction of deaf-mutes.

The two chief methods of conveying instruction to the deaf and dumb are by means of the manual alphabet, and by training them to watch the lips of the teacher during articulation. There are two kinds of manual alphabet: the double-handed alphabet, where the letters are expressed by the disposition of the fingers of both hands; and the single-handed, in which the letters are formed with the fingers of one hand. Particular gestures which are attached to each word as its distinctive sign are largely used, as are also real objects and models, pictures, &c. The method of teaching by articulation, the pupil learning to recognize words, and in time to utter them, by closely watching the motions of the lips and tongue in speech, and by being instructed through diagrams as to the different positions of the vocal organs, is now receiving much attention, and has given excellent results, cases being known where persons have conversed with the deaf and dumb and remained ignorant that those to whom they were speaking were afflicted in this way. It is by no means a novel system, but of late it has vastly increased in favour with authorities. A new mode of teaching articulation has recently been brought into notice, consisting in the use of the system of *visible speech* devised by Mr. Melville Bell. The characters of the alphabet on which this system is founded are intended to reveal to the eye the position of the vocal organs in the formation of any

sound which the human mouth can utter. Its practical value as a means of instruction with all classes of the deaf and dumb has not as yet been sufficiently tested.

Deafness, the partial or total inability to hear. This is a symptom of most affections of the ear. It may be due simply to an accumulation of wax. If it come on suddenly without pain in a healthy person this is probably the cause. When it comes on with a cold in the head it is the result of a cold or catarrh, and is likely to pass off in a few days. Attended by pain, ringing in the ears, &c., some degree of inflammation is likely present. The most intractable form of deafness comes on very gradually and painlessly, and is connected with disease of the middle ear. If a skilled ear-surgeon were consulted in time much might probably be done to stay its progress. Deafness due to the disease of the nerve of hearing is usually very intense, comes on suddenly or advances very rapidly, and is not easily reached by treatment. As to other causes of complete deafness see *Deaf and Dumb*.

Deák (dā'āk), FRANZ, Hungarian statesman, born of a noble Magyar family, 1803; died 1876. He was elected to the National Diet in 1832, and became the leader of the liberal party. At the revolution of 1848 he became minister of justice, but retired when Kossuth obtained power. On the defeat of the patriots in 1849 he retired from public life, and did not return till the Franco-Austrian war gave him an opportunity of serving his country. He is regarded as the master-spirit of the movement by which the ancient independence of his country was restored in 1867. Though the leader of the liberal party he constantly refused office, but no change in the ministry was made without his consent.

Deal (dēl), a seaport and watering-place, England, county Kent, between the North and South Foreland, 72 miles E. by S. of London. Walmer Castle, Sandown Castle, and Deal Castle are in the vicinity of the town. Boat-building and sail-making are carried on. There is a pier but no proper harbour; the well-known Downs afford excellent anchorage. Pop. 8422.

Deal, the division of a piece of timber made by sawing; a board or plank. The name deal is chiefly applied to boards of fir above 7 inches in width and of various lengths exceeding 6 feet. If 7 inches or less wide they are called battens, and when under 6 feet long they are called deal-ends.

The usual thickness is 3 inches, and width 9 inches. The standard size, to which other sizes may be reduced, is 1½ inch thick, 11 inches broad, and 12 feet long. *Whole deal* is deal which is 1½ inch thick; *slit deal*, half that thickness. Deals are exported from Prussia, Sweden, Norway, Russia, and British North America.

Deal-fish, the *Trachypterus arcticus*, so called from its excessively compressed body, a denizen of the northern ocean and an occasional visitor to the coasts of Iceland, Norway, and Britain; measures from 4 to 8 ft. in length; is of a silvery colour with minute scales, and has the dorsal fin extended along the whole length of the back. It is also known by the Scandinavian name Vaagmaer.

Dean (from L. *decānus*, from *decem*, ten), an ecclesiastical dignitary, said to have been so called because he presided over ten canons or prebendaries; but more probably because each diocese was divided into deaneries, each comprising ten parishes or churches, and with a dean presiding over each. In England, in respect of their differences of office, deans are of several kinds. *Deans of chapters* are governors over the canons in cathedral and collegiate churches. The *dean and chapter* are the bishop's council to aid him with their advice in affairs of religion, and they may advise, likewise, in the temporal concerns of his see. *Rural deans* were originally beneficed clergymen appointed by the bishop to exercise a certain jurisdiction in districts of his diocese remote from his personal superintendence, but their functions have for many years become almost obsolete. *Dean of the chapel royal*, in Scotland, is a title bestowed on six clergymen of the Church of Scotland, who receive from the crown a portion of the revenues which formerly belonged to the chapel royal in Scotland, and which are now in the gift of the crown.

Dean Forest, England, county of Gloucester. It formerly comprised the greater part of the county west of the Severn, but is now reduced to about 22,000 acres, nearly one-half of which is inclosed, and was formerly appropriated for the growth of navy timber, but is now mainly covered with coppices. This district is crown property, and the inhabitants (chiefly coal and iron miners) enjoy many ancient privileges. It contains a population of nearly 25,000.

Dean of Faculty.—(1) In some universities, as that of London and those of Scotland,

the chief or head of a faculty (as of arts, law, or medicine); in the United States, a registrar or secretary of the faculty in a department of a college, as in a medical, theological, or scientific department. (2) The president for the time being of an incorporation of barristers or law practitioners; specifically, the president of the incorporation of advocates in Edinburgh.

Dean of Guild, in Scotland, originally that magistrate of a royal burgh who was head of the merchant company or guildry; now the magistrate whose proper duty is to take care that all buildings within the burgh are sufficient, that they are erected agreeably to law, and that they do not encroach either on private or public property. He may order insufficient buildings to be taken down.

Death is that state of a being, animal or vegetable, but more particularly of an animal, in which there is a total and permanent cessation of all the vital functions, when the organs have not only ceased to act, but have lost the susceptibility of renewed action. Death takes place either from the natural decay of the organism, as in old age, or from derangements or lesions of the vital organs caused by disease or injury. The signs of actual death in a human being are the cessation of breathing and the beating of the heart; insensibility of the eye to light, pallor of the body, complete muscular relaxation, succeeded by a statue-like stiffness or rigidity which lasts from one to nine days; and decomposition, which begins to take place after the rigidity has yielded, beginning first in the lower portion of the body and gradually extending to the chest and face. What becomes of the mind or thinking principle, in man or animal, after death, is a matter of philosophical conjecture or religious faith.

Death, CIVIL, was the entire loss of forfeiture of civil rights; the separation of a man from civil society, or from the enjoyment of civil rights, as by banishment, abjuration of the realm, entering into a monastery, &c.

Death, DANCE OF, a grotesque allegorical representation in which the figure of Death, generally in the form of a skeleton, is represented interrupting people of every condition and in all situations, and carrying them away; so called from the mocking activity usually displayed by the figure of Death as he leads away his victims. It was frequently drawn by artists of the middle ages

for cemeteries and cloisters. These representations were common in Germany, and also in France, where they received the name of *Danse Macabre*, the derivation of which has been much disputed. The series attributed to Hans Holbein, the younger, was first published at Lyons in 41 plates, increased in a subsequent edition by 12 additional plates. A remarkable Dance of Death was painted, in fresco, on the walls of the churchyard in the suburb of St. John at Basel, which was injured, in early times, by being washed over, and is now entirely destroyed. This piece has been ascribed to Holbein; but it has long since been proved that it existed sixty years before his birth.

Death-rate, the proportion of deaths among the inhabitants of a town, country, &c. In Britain it is usually calculated at so many per thousand per annum.

Death's-head Moth, the largest species of lepidopterous insect found in Britain, and systematically known by the name of *Acherontia atropos*. The markings upon the back of the thorax very closely resemble a skull, or death's-head; hence the English name. It measures from 4 to 5 inches in expanse. It emits peculiar sounds, somewhat resembling the squeaking of a mouse, but how these are produced naturalists have not been able satisfactorily to explain. It attacks bee-hives, pillages the honey, and disperses the inhabitants. It is regarded by the vulgar as the forerunner of death or other calamity.

Death-watch, the popular name of the *Anobium tessellatum*, a coleopterous insect that inhabits the wood-work of houses. In calling to one another they make a peculiar ticking sound, which superstition has interpreted as a forerunner of death.

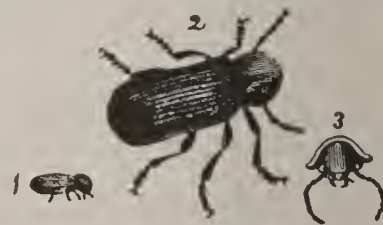

Death-watch Beetle (*A. tessellatum*).—1, Natural size. 2, Magnified. 3, Head as seen from underneath.

Débacle (dā'ba-kl), a sudden breaking up of ice in a river; used by geologists for any sudden outbreak of water, hurling before it and dispersing stones and other debris.

Debatable Land, a district of country on the western border of Scotland and England for a long time a cause of contention between the two countries and a refuge for outlaws. It was divided by royal commissioners in 1542.

Deben'ture, a deed-poll (declaratory deed) given by a public company in acknowledgment of borrowed money. It gives the holder the first claim for dividends, while the capital sum lent is usually assured on the security of the whole undertaking. With the deed, coupons or warrants for the payment of interest at specified dates are generally issued. Custom-house certificates of drawback are also termed debentures.

Deb'orah, a Hebrew seer or prophetess who lived in the time of the judges, by the aid of Barak delivered the northern tribes from the oppression of Jabin, and secured a peace of forty years' duration. The triumphal ode (Judges v.) attributed to her is a remarkable specimen of Hebrew poetry.

Debra Tabor, a town in Abyssinia, about 35 miles E. of Lake Dembea, at present the residence of the Abyssinian sovereign.

Debreczin (de-bret'sin), a town of Hungary, on the edge of the great central plain, 113 miles E. of Budapest. Its houses are mostly of a single story; the streets broad and unpaved. Among the principal edifices are the Protestant church and college. Chief manufactures are coarse woollens, leather, soap, tobacco-pipes, casks, &c., and a large trade is done in cattle. Debreczin is considered the head-quarters of Hungarian Protestantism. Pop. 1891, 56,996.

Debt, NATIONAL. See *National Debt*.

Decade (dek'ād; Latin, *decas*, *decadis*; Greek *dekas*, from *deka*, ten) is sometimes used for the number ten, or for an aggregate of ten. The books of Livy's Roman history are divided into decades. In the French revolution, decades, each consisting of ten days, took the place of weeks in the division of the year. The term is now usually applied to an aggregate of ten years.

Dec'agon, in geometry, a figure of ten sides and angles.

Decaisnea (de-kā'nē-a), a genus of plants, nat. order Lardizabalaceæ, growing on the Himalayas 7000 ft. above the sea. It sends up erect stalks like walking sticks, bearing leaves 2 ft. long. Its fruit, which resembles a short cucumber, contains a sweet, yellow, edible pulp.

Decalogue (dek'a-log; Gr. *deka*, ten, and *logos*, a word), the ten commandments, which, according to Exod. xx. and Deut. v., were given by God to Moses on two tables. The Jews call them the *ten words*. Jews and Christians have divided the ten commandments differently; and in some Catholic catechisms the second commandment has been

united with the first, and the tenth has been divided into two.

Decam'eron. See *Boccaccio*.

Decamps (dè-kän), ALEXANDRE GABRIEL, an eminent French painter, was born in Paris in 1803, killed while hunting at Fontainebleau 1860. His paintings include pictures of Oriental scenery and character, historical pictures, genre pictures, and animals.

De Candolle (dè kän-dol), AUGUSTIN PYRAME, one of the most illustrious of modern botanists, whose natural system of classification, with some modifications, is the one still generally used, was born at Geneva in 1778, died there 1841. He took up the study of medicine at Geneva and Paris, where he attracted the notice of Cuvier and Lamarck, whom he aided in various scientific researches. After returning to his native city he again visited Paris, and took his medical degree, selecting as the subject of his thesis the medical properties of plants. In 1804 he lectured in the College of France on vegetable physiology; and the following year published an outline of his course, under the title of *Principes de Botanique*, prefixed to the third edition of Lamarck's *Flore Française*. In this outline he laid the basis of the system of classification which he afterwards developed in larger and more celebrated works. In 1808 he obtained the chair of botany in the faculty of medicine at the University of Montpellier. In 1816 he returned to Geneva, where a chair of natural history was expressly created for him, and where he continued for many years to extend the boundaries of his favourite science by his lectures and publications. His chief works are: *L'Histoire des Plantes Grasses*; *Regni Vegetabilis Systema Naturale* (incomplete); *Théorie Élémentaire de Botanique*; *Organographie Végétale*; *Physiologie Végétale*; and *Prodromus Systematis Naturalis*, the latter completed by his son ALPHONSE (born 1806), also an eminent botanist and member of the French Institute.

Decan'dria, in the Linnæan system of botany, the tenth class of plants. The flowers have ten stamens, and one, two, three, or more pistils. It includes the pink, Lychnis, Saxifrage, &c.

Decapitiation, beheading, capital punishment inflicted by the sword, axe, or guillotine.

Decap'oda (Gr. *deka*, ten, and *pous*, *podos*, a foot).—(1) The highest order of crustaceans, so called from having five pairs of legs.

They are subdivided into *Brachyura*, the short-tailed decapods or crabs; *Macrura*, or long-tailed, including the shrimp, lobster, prawn, crayfish, &c.; and *Anomura*, of which the hermit-crab is an example. (2) One of the two divisions of the dibranchiate cuttlefishes (the other being the *Octopoda*). They have two arms longer than the other eight, and bear the suctorial discs only at the extremities.

Decap'olis, a district of ancient Palestine containing ten cities, partly on the east partly on the west of the Jordan.

Dec'astyle (Gr. *deka*, ten, and *stylos*, a column), a portico or colonnade of ten columns.

Deca'tur, a city and important railway centre of Illinois, U.S., 39 miles E. of Springfield. It has a large rolling-mill, and is a place of considerable trade. Pop. 16,841.

Deca'tur, STEPHEN, American naval commander, born 1779, killed in a duel 1820. Among the chief exploits of his life were the capture of the British frigate *Macedonian* in 1812; his attempted escape from the blockade of New York harbour, 1813-14; and his chastisement of the Algerines, 1815.

Decazeville (dè-káz-vél), a town of France, dep. Aveyron, with coal and iron mines and large iron-works. Pop. 6736.

Dec'can (Sanskrit, *Dakshina*, the south), a term locally limited to the territory of Hindustan lying between the Nerbudda and the Kistna, but generally understood to include the whole country south of the Vindhya Mountains, thus comprising the Presidency of Madras and part of Bombay, Hyderabad, Mysore, Travancore, and other native states.

Deceased Wife's Sister, MARRIAGE WITH, a question that has recently been much discussed in Britain. A bill to legalize marriage between a man and the sister of his deceased wife has been brought forward almost every session of parliament for many years back, and has passed the House of Commons several times, but has always as yet been rejected by the House of Lords. Such marriages are legal in the Australian colonies and in Canada (not to mention other countries), and thus there is a certain anomaly in their being prohibited in the home country.

Deceb'alus, the name of several Dacian kings, or perhaps a general title of honour borne by them. One of them distinguished himself by his opposition to the Roman arms during the reigns of Domitian and

Trajan. He entered the province of *Moesia*, defeated and killed Appius Sabinus, the Roman governor, and captured many important towns and fortresses. Domitian agreed to pay him a yearly tribute, which was continued by Nerva, but refused by Trajan, who subdued Dacia, and Decebalus, to escape falling into the hands of the victors, committed suicide.

Decem'ber, the twelfth month of our year, from the Latin *decem*, ten, because in the Roman year instituted by Romulus it constituted the tenth month, the year beginning with March. In December the sun enters the tropic of Capricorn, and passes the winter solstice.

Decem'virs, the ten magistrates who had absolute authority in ancient Rome (B.C. 451-449). See *Appius Claudius*.

Decid'uous is a term applied in botany to various organs of plants, particularly leaves, to indicate their annual fall. A tree of which the leaves fall annually is called a deciduous tree, and the same term is applied to the leaves themselves. The term is also applied in zoology to parts which fall off at a certain stage of an animal's existence, as the hair, horns, and teeth of certain animals.

Decimal Fractions. See *Fraction*.

Decimal System is the name given to any system of weights, measures, or money in which the unit is always multiplied by 10 or some power of 10 to give a higher denomination, and divided by 10 or a power of 10 for a lower denomination. This system has been rigidly carried out in France, and the principle obtains in the coinage of Belgium, Italy, Spain, Portugal, the United States, and other countries. To express the higher denominations, that is to say, the unit multiplied by 10, 100, 1000, 10,000, the French make use of the prefixes *déca*, *hecto*, *kilo*, *myria*, derived from the Greek; thus, the *mètre* being the unit of length, *décamètre* is 10 mètres, *hectomètre* 100 mètres, *kilomètre* 1000 mètres. To express lower denominations, that is, tenths, hundredths, &c., the Latin prefixes *déci*, *centi*, *milli* are used in the same way; thus a *centilitre* is the hundredth part of a *litre*, *décilitre* the tenth part of a *litre*. The basis of the whole system is the linear measure, the unit of which is the *mètre*, supposed to be the ten-millionth part of a quadrant of the earth's meridian (39·37 inches). The square of 10 mètres, or square *décamètre*, called an *are*, is the unit of surface measure. The cube

of the tenth part of the mètre, or cubic décimètre, called a litre, is the unit of liquid capacity. The cube of the mètre, called a *stère*, is the unit of solid measure. The weight of a cubic centimètre of distilled water at 39°·2 Fahr. (4° Centigrade), called a *gramme*, is the unit of weight. The unit of money is the *franc*, which is divided into *décimes* and *centimes*.

Decimation, the selection of the tenth man of a corps of soldiers by lot for punishment, practised by the Romans. Sometimes every tenth man was executed; sometimes only one man of each company, the tenth in order. The term is frequently used in a loose way for the destruction of a great but indefinite proportion of people, as of an army or inhabitants of a country.

Decius, C. MESSIUS QUINTUS TRAJANUS, a Roman emperor, who reigned from A.D. 249 to A.D. 251. He persecuted the Christians, and perished with his army in a battle near Abricium against the Goths.

Deck, a horizontal platform or floor extending from side to side of a ship, and formed of planking supported by the beams. In ships of large size there are several decks one over the other. The *quarter-deck* is that above the upper-deck, reaching forward from the stern to the gangway.

Decker, THOMAS. See *Dekker, Thomas*.

Declaration, an avowal or formal statement; especially a simple affirmation substituted in lieu of an oath, solemn affirmation, or affidavit, which English law allows in a variety of cases, such as those which relate to the revenues of customs or excise, the post-office, and other departments of administration. Justices of the peace, notaries, &c., are also empowered in various cases to take voluntary declarations in lieu of oaths, solemn affirmations, and affidavits.—*Declaration of Independence*, the solemn declaration of the Congress of the United States of America, on 4th July, 1776, by which they formally renounced their subjection to the government of Britain.—*Declaration of Paris*, an instrument signed at the Congress of Paris, 1856, and subsequently accepted by the chief powers. It declared (1) privateering to be abolished; (2) a neutral flag covers enemy's goods, with the exception of contraband of war; (3) neutral goods, except contraband of war, are not liable to capture under an enemy's flag; and (4) blockades, in order to be binding, must be effective.—*Declaration of War*, the formal notice which by the usage of nations belligerents

are expected to give before commencing hostilities.—*Declaration of Rights*, or *Bill of Rights*. See *Bill*.

Declar'ator, a form of action in the Scottish Court of Session by which some right of property, of status, &c., is sought to be judicially declared, leaving the legal consequences of the fact to follow as a matter of course.

Declension, in grammar, the aggregate of the inflections or changes of form which nouns, pronouns, and adjectives receive in certain languages according to their meaning or relation to other words in a sentence, such variations being comprehended under the three heads of number, gender, and case, the latter being the most numerous. See *Case*.

Declination, in astronomy, the distance of a heavenly body from the celestial equator (equinoctial), measured on a great circle passing through the pole and also through the body. It is said to be north or south according as the body is north or south of the equator. Great circles passing through the poles, and cutting the equator at right angles, are called *circles of declination*. Twenty-four circles of declination, dividing the equator into twenty-four arcs of 15° each, are called hour circles or horary circles.—Declination of the compass or needle, or *magnetic declination*, is the variation of the magnetic needle from the true meridian of a place. This is different at different places, and at the same place at different times. The declination at London was 11° 15' E. in 1576, 0° in 1652, 19° 30' W. in 1760, 24° 27' W., its maximum, in 1815, 21° 6' W. in 1865, 19° 15' W. in 1870, and 17° 49' in 1887.

Declinom'eter, an instrument for determining the magnetic declination, and for observing its variations. In magnetic observatories there are permanent instruments of this kind, and they are now commonly made self-registering. Such instruments register the small hourly and annual variations in declination, and also the variations due to *magnetic storms*.

Decomposition, CHEMICAL, is the separation of the constituents of a body from one another. Roughly speaking—for it is a difference of degree rather than of kind—decomposition is either artificial or spontaneous. Artificial decomposition is produced in bodies by the action of heat, light, electricity or chemical reagents; spontaneous, in bodies which quickly undergo change

in ordinary circumstances, unless special precautions are taken to preserve them. The bodies of the mineral, and the definite crystallized principles of the organic world, belong to the first; organized matter, such as animal and vegetable tissues, organic fluids, such as blood, milk, bile, and the complex non-crystallized bodies, albumen, gelatine, emulsine, &c., belong to the second.

Dec'orated Style, in architecture, the second style of pointed (Gothic) architecture, in use in Britain from the end of the 13th to the beginning of the 15th century, when it passed into the Perpendicular. It is distinguished from the Early English, from which it was developed, by the more flowing or wavy lines of its tracery, especially of its windows, by the more graceful combinations of its foliage, by the greater richness of the decorations of the capitals of its columns, and of the mouldings of its doorways and

niches, finials, &c., and generally by a style of ornamentation more profuse and naturalistic, though perhaps somewhat florid. The most distinctive ornament of the style is the ball-flower, which is usually inserted in a hollow moulding. (See *Ball-flower*.)

Decoration Day. The beautiful ceremony of decorating the graves of soldiers of the late civil war in the U. States, on the 30th of May of each year, is made possible through the organization of the Grand Army of the Republic, whose posts in every state of the Union keep records of soldiers' graves for the purpose. It is a legal holiday in several of the states.

Decoy', a place into which wild fowls are decoyed in order to be caught. A decoy

pond is kept only in a secluded situation. Several channels or pipes of a curved form, covered with light hooped net-work, lead from the pond in various directions. The wild fowl are enticed to enter the wide mouth of the channel by tamed ducks, also called decoys, trained for the purpose, or by

grain scattered on the water. When they have got well into the covered channel they are surprised by the decoy-man and his dog, and driven up into the funnel net at the far end, where they are easily caught. The details differ in different cases, but this is the general principle of the contrivance.

Decree', in general, an order, edict, or law made by a superior as a rule to govern inferiors. In law it is a judicial decision or determination of a litigated cause. Formerly, in England, the term was specially used for the judgment of a court of equity, but the word *judgment* is now used in reference to the

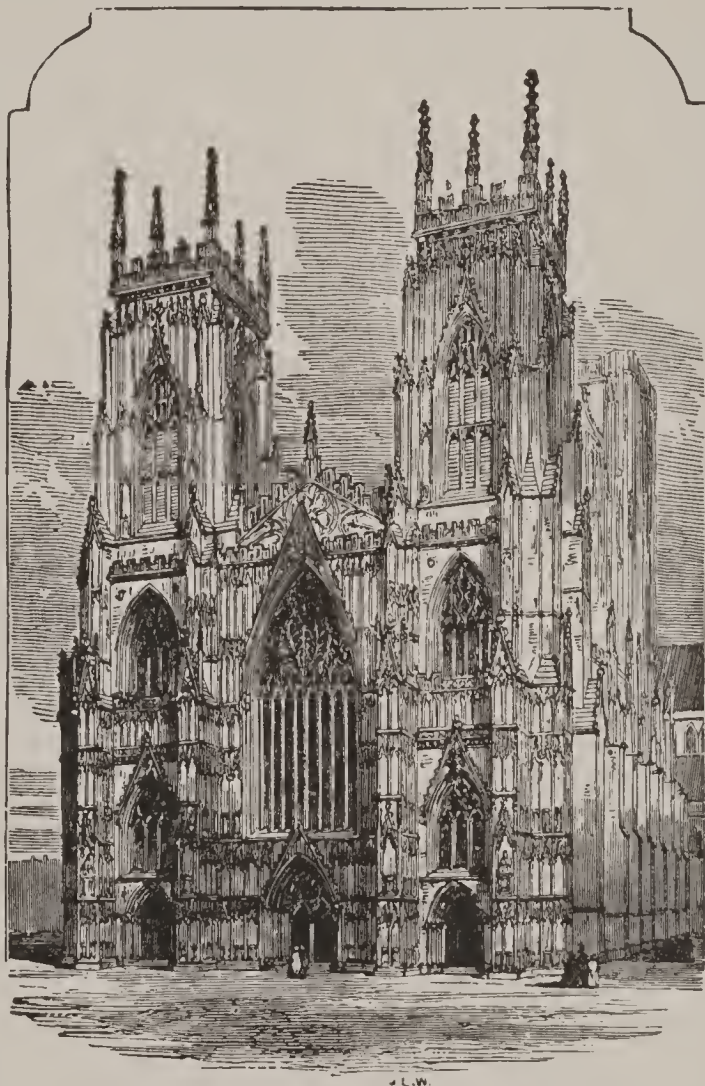

Decorated Style.—York Cathedral, West Front.

decisions of all the divisions of the supreme court. The word is still used in Scotland for the final judgment of a court, frequently in the form *decret*.

Decree Nisi, literally, a 'decree unless,' in England, is the decree of divorce issued by the court on satisfactory proof being given in support of a petition for dissolution of marriage; it remains imperfect for at least six months, and is then made absolute, 'unless' sufficient cause is shown why it should not be made so. If within the time appointed good reason can be shown for such a proceeding, the decree nisi will be reversed, or a further inquiry will be ordered.

Decrepita'tion, the act of flying asunder with a crackling noise on being heated, or

the crackling noise, attended with the flying asunder of their parts, made by several salts and minerals when heated. It is caused by the unequal sudden expansion of their substance by the heat, or by the expansion and volatilization of water held mechanically within them.

Decrescendo (dā-kre-shen'dō), an Italian term in music which denotes the gradual weakening of the sound, or the reverse of *crescendo*.

Decre'tals, a general name for the Papal decrees, comprehending the rescripts (answers to inquiries and petitions), decrees (judicial decisions by the *Rota Romana*), mandates (official instructions for ecclesiastical officers, courts, &c.), edicts (Papal ordinances in general), and general resolutions of the councils. The decretals form a most important portion of the Roman Catholic canon law, the authoritative collection of them being that made by the orders of Gregory IX. and published in 1234.

Dedham, the seat of Norfolk co., Mass., 12 miles s. w. of Boston. It has a public library, a savings bank, several factories, and 2 banks. Pop. 1890, 7116.

Dedica'tion, the act of consecrating something to a divine being, or to a sacred use, often with religious solemnities. Also an address prefixed to a book, and formerly inscribed to a patron, testifying respect and recommending the work to his protection and favour; now chiefly addressed to friends of the author, or to public characters, simply as a mark of affection or esteem.

Deduc'tion, in reasoning, the act or method of drawing inferences, or of deducing conclusions from premises; or that which is drawn from premises. See *Logic*.

Dee, the name of several British rivers. (1) A river of Scotland, partly in Kincardineshire, but chiefly in Aberdeenshire, one of the most finely wooded and one of the best salmon rivers in Britain. It rises on the s.w. border of Aberdeenshire, and flows generally eastward 87 miles to the German Ocean, having Aberdeen at its mouth. (2) A river of N. Wales and Cheshire; rises in Lake Bala, Merionethshire; flows N.E., N., and N.W. to the Irish Sea 20 miles below Chester; length about 80 miles. (3) A river of Scotland, county of Kirkcudbright, rises in Loch Dee, a lonely lake, 7 furlongs long and from $1\frac{1}{3}$ to 4 furlongs wide, situated among the western hills. It flows s.e. and s., and falls into Kirkcudbright Bay; length 38 miles.

Dee, JOHN, English mathematician, alchemist, and astrologer, born 1527, died 1608. In early life he successfully devoted much of his time to mathematical, astronomical, and chemical studies. In the reign of Mary he was imprisoned on suspicion of practising the 'black art;' but was in favour with Elizabeth, who is said to have employed him on secret political missions, and paid him a fixed salary. In 1581, along with a man named Kelly, he visited several of the Continental courts, pretending to raise spirits. In 1595 he obtained from the queen the wardenship of Manchester College. Here he resided for nine years, and then returned to his old residence at Mortlake, where he died, leaving behind him many works, partly of a scientific character, partly dealing with the occult sciences, invocation of spirits, &c.

Deed, in law, a writing containing some contract or agreement, and the evidence of its execution, made between parties legally capable of entering into a contract or agreement; particularly an instrument on paper or parchment, conveying real estate to a purchaser or donee. It is either an *indenture* or a *deed-poll*; the former made between two or more persons in different interests, the latter made by a single person, or by two or more persons having similar interests.

Deeg, a town and fortress in Bhurtpore, Central India, 57 miles north-west of Agra, situated in the midst of marshes, and almost surrounded by water during a great part of the year. At the south-west corner is a lofty rock, on which the citadel stands. It was taken in 1804 by General Fraser, and dismantled after the capture of Bhartpur by Lord Combermere. Pop. 15,828.

Deem'ster, an officer formerly attached to the High Court of Justiciary in Scotland, who formally pronounced the doom or sentence of death on condemned criminals. The office was conjoined with that of executioner. The name is now given in the Isle of Man to two judges who act as the chief-justices of the island, the one presiding over the northern, the other over the southern division. They hold courts weekly at Douglas, Ramsey, and other places.

Deer, a general name for the ungulate or hoofed ruminating animals constituting the family Cervidæ, of which the typical genus is *Cervus*, the stag or red-deer. The distinguishing characteristics of the genus are, that the members of it have solid branching horns which they shed every year, and

eight cutting teeth in the lower jaw and none in the upper. The horns or antlers always exist on the head of the male, and sometimes on that of the female. The forms of the horns are various; sometimes they spread into broad palms which send out sharp snags around their outer edges; sometimes they divide fantastically into branches, some of which project over the forehead, whilst others are reared upwards in the air; or they may be so reclined backwards that the animal seems almost forced to carry its head in a stiff erect posture. They are used as defensive and offensive weapons, and grow with great rapidity. There are many species of deer, as the red-deer or stag, the fallow-deer, the roebuck, the reindeer, the moose, the elk, the axis, rusa, muntjac, wapiti, &c. (See the separate articles.) Deer are pretty widely distributed over the world, though there are none in Australia and few in Africa, where the antelopes (whose horns are permanent) take their place. The reindeer alone has been domesticated.

Deer Forest, an extensive tract of mountainous land set apart for the protection of wild deer, especially red-deer, which are used for purposes of sport. In Scotland, to which such forests are chiefly confined, some 2,000,000 acres, distributed over nine or ten counties, are devoted to deer forests. The land is usually in by far the greater part of the wildest and least productive kind, but of course may yield large numbers of grouse and other game as well as deer. A great many of the forests are rented by sportsmen from the proprietors, and the rents drawn are considerable, ranging from £1000 to £5000, and even much more, per annum for a single forest. Crofters have often been removed from their holdings in order that the land might be incorporated in some deer forest, and this has been regarded as a great grievance. On the other hand, the lessees of the forests have expended large sums of money in the country, and the rents paid the proprietors have enabled them to do the same.

Deer-grass, the name of several N. American plants of the genus *Rhexia*.

Deering, Cumberland co., Me.; adjoins Portland; manufacturing town. Pop. 5353.

Deer-mouse, the common name of the animals belonging to the genus *Meriones*, an American genus of rodent animals allied to the mice and the jerboas of the Old World. The deer-mouse of Canada (*M. canadensis*) is a pretty little animal of the

size of a mouse, with very long hind-legs and tail, and very short fore-legs.

Deer-stalking, an exciting but laborious mode of hunting the red-deer, in which, on account of the extreme shyness of the game, their far-sightedness and keen sense of smell, they have to be approached by cautious manœuvring before a chance of obtaining a shot occurs. Great patience and tact and a thorough knowledge of the ground are essential to a good stalker, who has to undergo many discomforts in crouching, creeping, wading through bogs, &c. Advance from higher to lower ground is usually made, since the deer are always apt to look to the low ground as the source of danger. 'Deer-driving' towards a point where the shooters are concealed is often practised, but is looked on as poor sport by the true deer-stalker.

Defama'tion, the malicious uttering of slanderous words respecting another which tend to destroy or impair his good name, character, or occupation. To constitute defamation in law the words must be spoken maliciously. Defamation is punishable either by action at common law or by statute.

Default', in law, signifies generally any neglect or omission to do something which ought to be done. Its special application is to the non-appearance of a defendant in court when duly summoned on an appointed day. If he fail to appear judgment may be demanded and given against him by default.

Defen'dant, in law, the party against whom a complaint, demand, or charge is brought; one who is summoned into court, and defends, denies, or opposes the demand or charge, and maintains his own right. The term is applied even if the party admits the claim.

Defender of the Faith (*Fidei Defensor*), a title belonging to the King of England, as *Catholicus* to the King of Spain, *Christianissimus* to the King of France, &c. Leo X. bestowed the title of *Defender of the Faith* on Henry VIII. in 1521, on account of his book against Luther, and the title has been used by the sovereigns of England ever since.

Deffand (def-än), MARIE DE VICHY-CHAMRON, MARQUISE DU, a conspicuous character among the French literati of the 18th century, born 1697, died 1780. In 1718 she married the Marquis du Deffand, from whom she separated after ten years. During the latter part of her long life she became the centre of a literary coterie, which included Choiseul, Boufflers, Montes-

quiou, Voltaire, D'Alembert, David Hume, and Horace Walpole. She possessed much natural talent; but the laxity of her morals formed a strong contrast to the superiority of her intellectual powers.

Defiance, Defiance co., O. Pop. 7694.

Defila'ding, that branch of fortification the object of which is to determine (when the intended work would be commanded by eminences within the range of firearms) the directions or heights of the lines of rampart or parapet, so that the interior of the work may not be incommoded by a fire directed to it from such eminences.

Defile, a narrow passage or way in which troops may march only in a file, or with a narrow front; a long narrow pass, as between hills, &c.

Definition, a brief and precise description of a thing by its properties; an explanation of the signification of a word or term, or of what a word is understood to express. Logicians distinguish definitions into *nominal* and *real*. A nominal definition explains the meaning of a term by some equivalent word or expression supposed to be better known. A real definition explains the nature of the thing. A real definition is again *accidental*, or a description of the accidents, as causes, properties, effects, &c.; or *essential*, which explains the constituent parts of the essence or nature of the thing. An essential definition is, moreover, *metaphysical* or *logical*, defining 'by the genus and difference,' as it is called; as, for example, 'a plant is an organized being, destitute of sensation,' where the part first of the definition states the genus (organized being), and the latter the difference (destitute of sensation, other organized beings possessing sensation); or *physical*, when it distinguishes the physical parts of the essence; thus, a plant is distinguished by the leaves, stalk, root, &c. A strictly accurate definition can be given of only a few objects. The most simple things are the least capable of definition, from the difficulty of finding terms more simple and intelligible than the one to be defined.

Defoe (dē-fō'), DANIEL, an English writer of great ingenuity and fertility, was born in 1661 in London, where his father, James Foe, carried on the trade of a butcher. In 1685 he joined the insurrection of the Duke of Monmouth, and had the good fortune to escape; after which he made several unsuccessful attempts at business, and at last turned his attention to literature. In

1701 appeared his satire in verse, *The True-born Englishman*, in favour of William III. As a zealous Whig and Dissenter he was frequently in trouble. For publishing *The Shortest Way with the Dissenters* (1702), the drift of which was misunderstood by both Churchmen and Dissenters, he was pilloried and imprisoned in Newgate, obtaining his liberty through the influence of Harley, who employed him in several important missions, particularly in the negotiations for the union with Scotland, of which he wrote the history. While in Newgate, in 1704, he commenced the *Review*, a literary and political periodical which lasted for nine years. In 1705 he wrote a short account of the Apparition of Mrs. Veal, a fictitious narrative accompanying a translation of Drelincourt on Death. In 1706 he published his largest poem, entitled *Jure Divino*, a satire on the doctrine of divine right. In 1707 he was in Scotland, which he also visited several times subsequently in connection with political affairs, and as an agent of those in power. In 1719 appeared the most popular of all his performances: *The Life and Surprising Adventures of Robinson Crusoe*, the favourable reception of which was immediate and universal. The success of Defoe in this performance induced him to write a number of other lives and adventures in character; as *Moll Flanders*, *Captain Singleton*, *Roxana*, *Duncan Campbell*, *The Memoirs of a Cavalier*, *Journal of the Plague*, &c. After the accession of George I. he was employed by government in some underhand work connected with the obnoxious Jacobite press, and was a prolific contributor to periodical and ephemeral literature. He died in London in 1731.

Deforcement, in law, the holding of lands or tenements to which another person has a right; a general term including any species of wrong by which he who has a right to the freehold is kept out of possession. In Scots law, it is the resisting of an officer in the execution of law.

De Gérando (dè zhā-rān-dō), JOSEPH MARIE, BARON, a French philosopher and statesman, born in Lyons 1772, died 1842. After serving in the army for some time he took office as minister of the interior under Lucien Bonaparte, and was afterwards engaged in the organization of Tuscany and the Papal States on their union to France. In 1819 he commenced a course of lectures in the *Faculté de Droit*, in Paris, on public and administrative law. He was raised to

the peerage in 1837. De Gérando has acquired great fame by his philosophical writings. His principal works are *Des Signes et de L'Art de Penser*; *De la Génération des Connaissances Humaines*; *Histoire comparée des Systèmes de Philosophie*; *Du Perfectionnement Moral et de l'Éducation de Soi-même*; *De l'Éducation des Sourds-muets de Naissance*; and *De la Bienfaisance Publique*.

Deg'gendorf, a town of Bavaria, on the Danube, with manufactures of cloth, &c. Pop. 6226.

Degradation, the ecclesiastical censure by which a clergyman is divested of his holy orders. The canon law distinguishes degradation into two sorts: the one summary, by word only; the other solemn, by stripping the person degraded of those ornaments and rights which are the ensigns of his order or degree. The term is also applied to the deprivation of offices not ecclesiastical.

Degree', in geometry or trigonometry, the 360th part of the circumference of any circle, the circumference of every circle being supposed to be divided into 360 equal parts, called degrees. A *degree of latitude* is the 360th part of the earth's circumference north or south of the equator, measured on a great circle at right angles to the equator, and a *degree of longitude* the same part of the surface east or west of any given meridian, measured on a circle parallel to the equator. Degrees are marked by a small ° near the top of the last figure of the number which expresses them; thus 45° is 45 degrees. The degree is subdivided into sixty equal parts called minutes; and the minute is again subdivided into sixty equal parts called seconds. Thus, 45° 12' 20" means 45 degrees, 12 minutes, and 20 seconds. The magnitude or quantity of angles is estimated in degrees and parts of a degree, because equal angles at the centre of a circle are subtended by equal arcs, and equal angles at the centres of different circles are subtended by similar arcs, or arcs containing the same number of degrees and parts of a degree. An angle is said to be so many degrees as are contained in the arc of any circle intercepted between the lines which contain the angle, the angular point being the centre of the circle. Thus we say an angle of 90°, or of 45° 24'. It is also usual to say that a star is elevated so many degrees above the horizon, or declines so many degrees from the equator, or such a town is

situated in so many degrees of latitude or longitude. The length of a degree depends upon the radius of the circle of the circumference of which it is a part, the length being greater the greater the length of the radius. Hence the length of a degree of longitude is greatest at the equator, and diminishes continually towards the poles, at which it = 0. Under the equator a degree of longitude contains 60 geographical, and 69½ statute miles. The degrees of latitude are found to increase in length from the equator to the poles, owing to the figure of the earth. Numerous measurements have been made in order to determine accurately the length of degrees of latitude and longitude at different parts of the earth's surface and thus settle its dimensions and magnitude. When the French determined to establish their system of measures and weights based upon the mètre (see *Decimal System*), they settled that this basis was to be the ten-millionth part of the distance from the equator to the pole, which distance had to be found by accurate measurement. Ten degrees of latitude were accordingly measured, from Dunkirk to Formentera, one of the Balearic islands. Similar measurements having been made in Britain, the length of a total arc of twenty degrees has been found. Many measurements have also been made elsewhere. The term is also applied to the divisions, spaces, or intervals marked on a mathematical, meteorological, or other instrument, as a thermometer or barometer.

Degree, in universities, a mark of distinction conferred on students, members, or distinguished strangers, as a testimony of their proficiency in the arts or sciences, or as a mark of respect, the former known as ordinary, the latter as honorary degrees. The degrees are bachelor, master, and doctor, and are conferred in arts, science, medicine, divinity, and music. Degrees are conferred on women by London University; Cambridge admits them to the tripos examinations; and Oxford to most of its honour schools; but neither grants at present the stamp of a degree. St. Andrew's University grants the title L.L.A. to women who pass in four subjects; the standard of attainment being the same as that required for the M.A. degree, the books prescribed and the questions set being practically identical.

Degree, in algebra, a term used in speaking of equations, to express what is the highest power of the unknown quantity. Thus

if the index of that power be 3 or 4 (x^3 , y^4), the equation is respectively of the third or fourth degree.

Dehra (dā'ra), a town of Hindustan, capital of Dehra Doon, beautifully situated, with military cantonments, English, Presbyterian, and R. Catholic churches, and an American mission. Pop. 18,959.

Dehra Doon (dā'ra), a beautiful and fertile valley in the Meerut division of the North-western Provinces, Hindustan, at the s.w. base of the lowest and outermost ridge of the Himalaya. It is bounded on the n. by the Jumna, n.e. by the mountains of Gurwhal, from 7000 to 8000 ft. high, s.e. by the Ganges, s.w. by the Sewalik range, 3000 to 3500 ft. high. Its length from s.e. to n.w. is about 45 miles; breadth, from 15 to 20 miles. The chief town in the valley is Dehra.

Dei gratia (dē'i grā'shi-a; 'by the grace of God'), a formula which sovereigns add to their title. The expression is taken from several apostolical expressions in the New Testament.

Deinosauria. See *Dinosauria*.

Deioces (dī'o-sēz), who flourished about seven centuries B.C., rose from a private station to be the founder of the Median Empire. By acting as arbitrator in the disputes which took place in his own vicinity, the fame of his justice induced the Medes to choose him for their king after their revolt from the Assyrians. He built the city of Ecbatāna, in which he resided; after a reign of thirty-five years he left the throne to his son Phraortes.

Deira (de'i-ra), an ancient Anglian kingdom, stretching from the Tees to the Humber, and extending inland to the borders of the British realm of Strathclyde. With Bernicia it formed the Kingdom of Northumbria.

De'ism (Lat. *Deus*, God), a philosophical system which, as opposed to *Atheism* (Gr. *a*, not, and *Theos*, God), recognizes a great First Cause; as opposed to *Pantheism* (Gr. *pan*, all, *Theos*), a Supreme Being distinct from nature or the universe; while, as opposed to *Theism*, it looks upon God as wholly apart from the concerns of this world. It thus implies a disbelief in revelation, scepticism as regards the value of miraculous evidence, and an assumption that the light of nature and reason are the only guides in doctrine and practice. It is thus a phase of Rationalism. In the last century there were a series of writers who are

spoken of distinctively as the English deists. They include Collins, Toland, Tindal, &c.

Dejani'ra, in Greek mythology, the wife of Hercules or Heracles (which see).

Dekker, or DECKER, JEREMIAS DE, a Dutch poet, born in 1609 or 1610, died 1666. His best-known poems are *Lof der Geldzucht*, a satire on avarice; and *Puntdichten*, a collection of epigrams.

Dekker, DECKER, or DECKAR, THOMAS, an English dramatic and miscellaneous writer, born about 1570, died 1641. He was a voluminous writer, and besides a great number of pamphlets, he wrote many plays which give a vivid picture of contemporary life in London. Among these are: *Old Fortunatus*, *Shoemaker's Holiday*, *Satiromastix*, *The Honest Whore*, &c. He also collaborated with Massinger, Ford, Middleton, Jonson, and others. A quarrel with Ben Jonson occasioned that poet's *Poetaster*, and the *Satiromastix* of Dekker.

De la Beche, SIR HENRY. See *Beche*, *Sir Henry de la*.

Delaborde (dè-là-bōrd), HENRY FRANÇOIS, COUNT, a French general, born at Dijon in 1764, died 1833. He distinguished himself in the republican armies; fought through the whole of the Napoleonic wars, and was ennobled in 1807. After the second restoration he was placed on the list of the officers who were to be criminally prosecuted, but in consequence of a technical error the case against him lay over, and he lived retired and unannoyed till his death.

Delacroix (dè-là-krwä), FERDINAND VICTOR EUGÈNE, an eminent French painter, born 1799, died 1863. He is considered the chief of the modern French romantic school of painters. His chief pictures up to 1830 are: *Dante and Virgil in the Infernal Regions*, *Massacre in Scio*, the *Execution of the Doge Marino Falieri*, the *Death of Sardanapalus*, the *Murder of the Bishop of Liège*. In 1831 he joined the embassy sent by Louis Philippe to the Emperor of Marocco. To this journey we are indebted for several pictures remarkable for their vivid realization of oriental life as well as their masterly colouring. They are: *The Jewish Marriage*, *Muley Abderrhaman with his Body-guard*, *Algerian Ladies in their Chamber*, *Moorish Soldiers at Exercise*, and several scenes of common life. He decorated several of the public buildings of Paris, and was admitted into the Institute in 1857. He was an artist of great versatility, strong in colouring but weak in drawing.

Delago'a Bay, in South-east Africa, a large sheet of water separated from the Indian Ocean by the peninsula and island of Inyack. The bay stretches north and south upwards of 40 miles, with a breadth of from 16 to 20 miles, and forms the southern extremity of the Portuguese settlement of Mozambique. It is available for vessels of large tonnage, though the presence of shoals, banks, and flats renders the navigation of the bay somewhat intricate. The port and Portuguese settlement of Lourenço Marques is becoming a place of considerable trade since the opening of gold-mines in the Transvaal. A railway running towards the Transvaal has been opened for a distance of over 50 miles.

Delambre (dè-lân-br), JEAN BAPTISTE JOSEPH, French astronomer and pupil of Lalande, born at Amiens in 1749, died 1822. His studies were not directed to astronomy until his thirty-sixth year, but he rapidly acquired fame, and produced numerous works of great value. He was engaged with Méchain from 1792 till 1799, in measuring an arc of the meridian from Barcelona to Dunkirk. In 1807 he succeeded Lalande in the Collège de France, and wrote his *Traité d'Astronomie Théorique et Pratique* (three vols. 4to, 1814), *Histoire de l'Astronomie du Moyen Age* (1819), *Hist. de l'Astron. Moderne* (1821), two vols., and *Hist. de l'Astron. du 18me Siècle* (two vols.).

Delane', JOHN THADDEUS, born 1817, died 1879; became editor of the *Times* in 1841, and retained that important post till 1877, during which time that paper attained an almost unparalleled influence and a great circulation.

Delaroche (dè-là-rosh), HIPPOLYTE (familiarily styled PAUL), probably the greatest painter of the French school, born in Paris in 1797, died 1856. He studied landscape-painting for a short time, but applied himself afterwards to historical painting, and rapidly rose to eminence. His subjects are principally taken from French and English history. Among others may be mentioned: St. Vincent de Paul preaching before Louis XIII. on behalf of Deserted Children; Joan of Arc interrogated in Prison by Cardinal Beaufort; the Death of Queen Elizabeth, a work greatly admired by French and generally reprobated by English critics; A scene of the St. Bartholomew Massacre; The Children of Edward IV. in the Tower; Cardinal Richelieu conducting Cinq Mars and De Thou up the Rhone to Execution;

Charles I. mocked by his guards; Cromwell contemplating the Dead Body of Charles I.; the Execution of Lady Jane Grey; the Death of the Duke of Guise; and the Hemicycle, an immense work painted in oil on the wall of the *École des Beaux Arts*, Paris. It represents an assemblage of the great painters, sculptors, and architects from the days

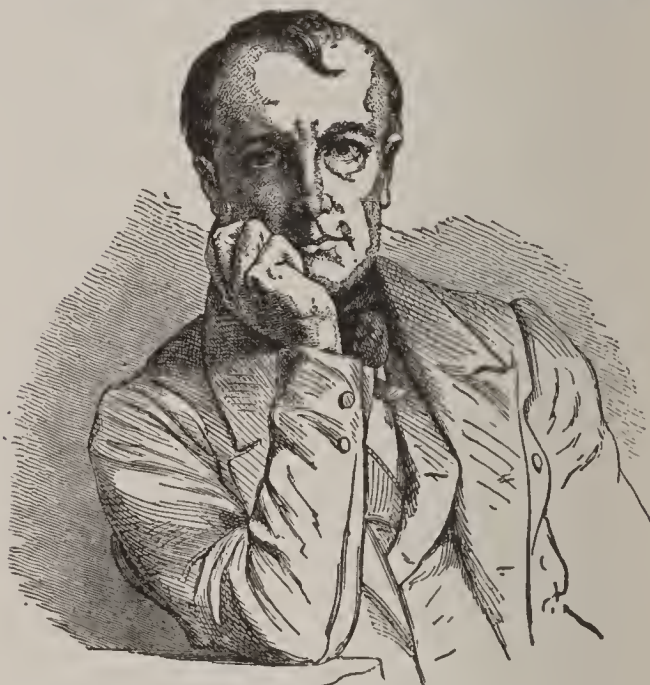

Paul Delaroche.

of Giotto to those of Lesueur, and has been admirably engraved by Dupont. His merits consist in correct drawing, appropriate expression, harmonious colour, and great distinctness and perspicuity in treatment, rendering the story of his pictures at once intelligible. He held a middle place between the classical and the romantic schools, and was regarded as the leader of the so-called 'eclectic school.'

Delavigne (dè-là-vèny), JEAN FRANÇOIS CASIMIR, a French poet and dramatist, born at Havre 1793, died 1843. At the restoration he published a set of elegies, entitled *Les Messéniennes*, which deplored the faded glories of France. He produced in 1819 his tragedy of *Les Vêpres Siciliennes*; *Les Comédiens* appeared in 1820, and the tragedy of *Le Paria* in 1821. Of his other plays which followed these may be mentioned: *L'École des Vieillards*; *Marino Faliero*; and the dramas of Louis XI.—founded on *Commines' Memoirs* and *Quentin Durward*—and *Don Juan d'Autriche*. His hymns *La Parisienne* and *La Varsoivienne*, and the ballad *La Toilette de Constance*, are among his more popular poetical pieces. He died a member of the Academy.

Del'aware, a river of the United States, which rises in Catskill Mountains in New York, separates Pennsylvania from New York and New Jersey, and New Jersey from Delaware, and loses itself in Delaware Bay. It has a course of about 300 miles, and is navigable for large vessels to Philadelphia, and for smaller craft to the head of tide-water at Trenton (155 miles).

Delaware, one of the original thirteen United States of North America, and, next to Rhode Island, the smallest state in the Union, named after Lord Delaware, one of the early governors of Virginia. It is bounded north by Pennsylvania, east by the Delaware River and Bay and by the ocean, south and west by Maryland; area, 2050 square miles. It is divided into three counties, Kent, Newcastle, and Sussex, and has nearly the form of a right-angled triangle (hence its popular name 'the diamond state'). In the south and towards the coast the surface is very level, but the north part is rather hilly. An elevated swampy table-land towards the west traverses the state, forming the water-shed between the Bay of Chesapeake and the Delaware. A great part of the soil is fertile, and agriculture is in a flourishing state. Fruit cultivation (peaches, apples, berries) is largely engaged in, and the canning and drying of fruits are important industries. There are also extensive and varied manufactures. A ship canal connects Chesapeake River and Delaware Bay. There are about 300 miles of railway. Wilmington is the chief manufacturing and commercial town. The capital is Dover. Delaware, though slaveholding, remained loyal to the Union at the secession of the Southern States. Pop. 168,493 (over 29,000 being coloured).

Delaware, an American city in co. of same name, Ohio; a place of considerable trade; the seat of the Ohio Wesleyan University. There are celebrated medicinal springs in the vicinity. Pop. 8224.

Delaware Bay, an estuary or arm of the sea between the states of Delaware and New Jersey. At the entrance, near Cape Henlopen, is situated the Delaware Breakwater, which affords vessels a shelter within the cape. It was erected by the Federal government, and cost about \$3,000,000.

Delaware Indians, a tribe belonging to the Algonquin family, originally known as living on the Delaware river, and called by themselves *Lenni Lenape*. They had to leave their original settlements about the

middle of last century, going farther west, and latterly they were removed to the Indian Territory. Their numbers are now insignificant.

Del Credere (kred'e-rā), an Italian mercantile phrase, similar in import to the English *guarantee* or the Scotch *warrantice*. It is used among merchants to express the obligation undertaken by a factor, broker, or mercantile agent, when he becomes bound, not only to transact sales or other business for his constituent, but also to guarantee the solvency of the persons with whom he contracts. On account of this guarantee a higher commission, called a *del credere* commission, is paid to the factor or agent.

Deleb' Palm, the *Borassus Æthiöpum*, a native of the interior and west of Africa, allied to the Palmyra palm. Its leaves and fruits are used by the Africans for the same purposes as those of the Palmyra by the Asiatics, and the tender roots produced by the young plant are extensively used as an article of food.

Del'egate, a person appointed and sent by another or by others, with powers to transact business as his or their representative. The title was given to members of the first continental congress in America, 1774. Representatives to Congress from the U. S. Territories are still designated by this term. They have the right of discussion, but have no vote.

Delescluze (dè-lā-klüz), LOUIS CHARLES, a French communist, born in 1809. He adopted a journalistic career and was imprisoned and fined for his socialistic and revolutionary articles, and also sentenced to banishment. He escaped to England, but having returned to France (1853) was kept in prison for some time and then banished to Cayenne. On his return he again got into trouble. After the fall of the empire and the German occupation he became a prominent member of the Commune, and was shot at one of the barricades in 1871.

Delfs'haven, a town of Holland, on the Maas, 2 miles s.w. Rotterdam. It is well protected from inundation by dikes, &c., and has ample accommodation for shipping. Pop. 12,705.

Delft, formerly DELF, a town, Holland, 8 miles n.w. Rotterdam, intersected in all directions by canals. Among its buildings are the town-hall, the Prinsen-hof, the scene of the assassination of William the Silent, now a military barrack; the old Reformed church, containing the monuments of Ad-

DELFT-WARE — DELHI.

miral Tromp, the naturalist Leeuwenhoek, &c.; the new church, containing monuments to William I., Hugo Grotius, and the burial-vaults of the present royal family. Delft was formerly the centre of the manufacture of the pottery called *delft-ware*; its chief industries now embrace carpets, leather, soap, oil, gin, &c. Pop. 1892, 30,079.

Delft-ware, or DELF, is a kind of pottery covered with an enamel or white glazing

which gives it the appearance of porcelain. It was originally manufactured in Delft in the 14th century, is now considered coarse, but was among the best of its day.

Delfzyl (delf'zil), a strongly-fortified town and port of North Holland, prov. Groningen, on the Dollart. Pop. 5997.

Delhi (del'i), a city of Hindustan, in the Punjab, anciently capital of the Patan and Mogul Empires, about 954 miles N.W. Cal-

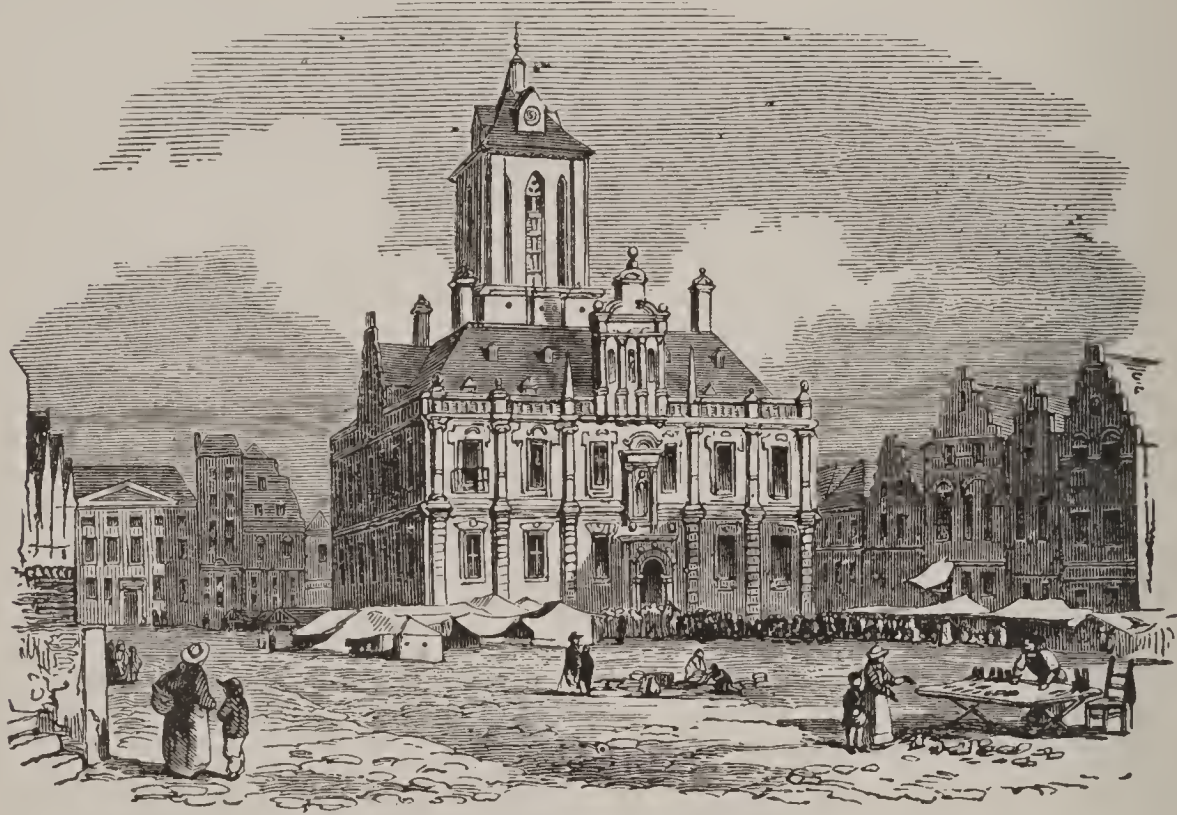

The Town-hall, Delft.

cutta. It was at one time the largest city in Hindustan, covering a space of 20 square miles, and having a population of 2,000,000. A vast tract covered with the ruins of palaces, pavilions, baths, gardens, mausoleums, &c., marks the extent of the ancient metropolis. The present city abuts on the right bank of the Jumna, and is surrounded on three sides by a lofty stone wall $5\frac{1}{2}$ miles long, strengthened by the British at the beginning of this century with a ditch and glacis. The palace or residence of the Great Mogul, built by Shah Jehan, commenced in 1631, and now known as 'the fort,' is situated in the east of the city, and abuts directly on the river. It is surrounded on three sides by an embattled wall of reddish sandstone nearly 60 feet high, with round towers at intervals, and a gateway on the west and south. Since the mutiny in 1857 a great portion has been demolished

in order to make room for military barracks. One of the most remarkable objects in the city is the Jamma Musjid or Great Mosque, a magnificent structure in the Byzantine-Arabic style, built by the Emperor Shah Jehan in the 17th century. Among modern buildings are the government college, founded in 1792 (abolished as a college); the Residency, and a Protestant church. The East Indian Railway enters the city by a bridge over the Jumna. The s.w. quarter of the town is densely occupied by the shops and dwellings of the native population; the streets are narrow and tortuous, but some of the main thoroughfares of the city are splendid streets, the chief being the Chandni Chauk, or 'Silver Street.' During the mutiny Delhi was seized by the Sepoys, who held possession for four months, during which many atrocities were committed. Pop. 1891, 193,580.

Delille (dè-lèl), JACQUES, a French didactic poet, born in 1738, died 1813. His translation of Virgil's *Georgics*, published in 1770, with a *Discours Préliminaire* and numerous annotations, established his fame, and obtained him admission to the French Academy. He became professor of Latin poetry in the College of France, and of belles-lettres at the University of Paris. Though an adherent of the old system, Robespierre spared him on every occasion. At his request Delille wrote the *Dithyrambe sur l'Immortalité de l'Âme*, to be sung on the occasion of the public acknowledgment of the Deity. In 1794 he withdrew from Paris, but returned again in 1801, and was chosen a member of the Institute. He spent two years in London, chiefly employed in translating *Paradise Lost*. His reputation mainly rests on the *Georgics*, and *Les Jardins*, a didactic poem. Other works are *L'Homme des Champs*, *La Pitié*, *Les Trois Règnes de la Nature*, *La Conversation*, *L'Énéide de Virgile*, &c.

Deliques'cence, a change of form from the solid to the liquid state, by the absorption of moisture from the atmosphere. It occurs in many bodies, such as caustic potash, carbonate of potassium, acetate of potassium, chloride of calcium, chloride of copper, chloride of zinc, &c. &c.

Delir'ium, a temporary disordered state of the mental faculties occurring during illness either of a febrile or of an exhausting nature. It may be the effect of disordered or inflammatory action affecting the brain itself, or it may be sympathetic with active diseases in other parts of the body, as the heart; it may be caused by long-continued and exhausting pain, and by a state of inanition of the nervous system.

Delir'ium Tre'mens, an affection of the brain which arises from the inordinate and protracted use of ardent spirits. It is therefore almost peculiar to drunkards. The principal symptoms of this disease, as its name imports, are delirium and trembling. The delirium is a constant symptom, but the tremor is not always present, or, if present, is not always perceptible. Frequently the sufferer thinks he sees the most frightful, grotesque, or extraordinary objects, and may thus be put into a state of extreme terror. It is properly a disease of the nervous system. The common treatment is to administer soporifics so as to get the patient to sleep.

Delisle (dè-lèl), GUILLAUME, French geo-

grapher, born in 1675, died 1726. He published upwards of 130 maps, and reconstructed the system of geography current in Europe in the beginning of the 18th century. Louis XV. appointed him Geographer to the King.—His brother, JOSEPH NICOLAS, born 1688, died 1768, was a distinguished astronomer, geographer, and mathematician. He visited England, where he formed acquaintance with Newton and Halley.

Delitzsch (dā'lēch), a town of Prussian Saxony, on the Lösser, 15 miles north of Leipzig, with manufactures of woollens, and several important annual fairs. Pop. 8225.

Delitzsch, FRANZ, German theologian, born at Leipzig 1813. He is a strong supporter of strict orthodox theology; became professor of theology at Rostock in 1846, at Erlangen in 1850, and at Leipzig in 1867. He has published many devotional and theological works and several valuable commentaries.—His son FRIEDRICH, born 1850, has distinguished himself in Assyriology, and is professor of that subject at Leipzig.

Della Cruscans, a coterie of English poetasters resident for some time in Florence, who printed inferior sentimental poetry and prose in 1785. Coming to England, they communicated the infection to minds of a like stamp, and the newspapers of the day, chiefly the *World* and the *Oracle*, began to give publicity to their lucubrations. They were extinguished by the bitter satire of Gifford's *Baviad* and *Mæviad*. Mrs. Piozzi, Boswell, Merry, Cobb, Holcroft, Mrs. H. Cowley, and Mrs. Robinson were the leaders. They took the name from the *Accademia Della Crusca* in Florence.

Della Robbia, LUCA, Italian sculptor, born 1400 at Florence, died 1482. He was distinguished for his work both in marble and bronze, and also for his reliefs in terra-cotta coated with enamel, a kind of work named after him. Other members of the family distinguished themselves in the same line, especially ANDREA (1435–1525), nephew and pupil of Luca.

Della Robbia Ware, terra-cotta bas-reliefs thickly enamelled with tin-glaze; made at Florence (chiefly in 1450–1530); in France (1530–1567); so called from the name of the above artist.

Dellys, a seaport of Algeria, 49 miles east of Algiers. It consists of a French and an Arab town; the climate is salubrious, and there is a trade in grain, oil, and salt. Pop. 13,288.

Delolme (dè-lolm), JEAN LOUIS, Swiss writer, born at Geneva in 1740, died 1806. He at first practised as a lawyer in his native city, but the part which he took in its internal commotions obliged him to repair to England, where he passed some years in great indigence. He became known by his celebrated *Constitution de l'Angleterre*.

De Lome, DUPUY, the Spanish Minister at Washington, Feb., 1898, had abstracted from his desk a letter reflecting on the executive and government of the U. States. He wrote of the President as "a coarse and low politician and catering to the rabble." He resigned before a demand for his recall.

Deloo' (*Cephalolophus grimmia*), a small but pretty antelope occurring over a great part of Central and Southern Africa.

Delorme (dè-lorm), MARION, a celebrated French beauty who reigned under Louis XIII. The date of her birth is stated at 1611, 1612, and 1615. Her beauty and wit soon made her house the rendezvous of all that was gallant and brilliant in Paris. She espoused the side of the Frondeurs, and Mazarin was about to have her arrested when her sudden death terminated her short career of thirty-nine years. The legend is current in France that the death and funeral was a mere pretence; that she escaped to England, returned to Paris, and after marrying three husbands lived to the age of 129. Victor Hugo has taken her as the subject of one of his dramas.

De'los, an island of great renown among the ancient Greeks, fabled to be the birth-place of Apollo. It was a centre of his worship, and the site of a famous oracle. It is the central and smallest island of the Cyclades, in the Ægean Sea, a rugged mass of granite about 12 square miles in extent. At first the island, occupied by the Ionians, had kings of its own, who also held the priestly office. In 477 B.C. it became the common treasury of the Greeks who were leagued against Persia. Subsequently the Athenians removed the inhabitants from it, but they were soon restored. Its festivals were visited by strangers from all parts of Greece, Asia Minor, &c. After the destruction of Corinth (146 B.C.) the rich Corinthians fled thither, and made Delos the seat of a flourishing commerce. The greatest curiosity of the island was the Temple of Apollo. The Persians, when they made war against Greece, forebore attacking the island out of reverence to the patron deities. The Delians showed great skill and taste in making uten-

sils, statues of their gods, figures of heroes, animals, &c., in bronze and silver. Delos, called *Dili* or *Sdili*, is now without permanent inhabitants; a few shepherds from the neighbouring isles pay it summer visits with their flocks. Abundant ruins of its former magnificence yet exist, and excavations resulting in interesting archæological discoveries have recently been made.

Delphi, an ancient Greek town, originally called Pytho, the seat of the famous oracle of Apollo, was situated in Phocis, on the southern side of Parnassus, about 8 miles north of the Corinthian Gulf. It was also one of the meeting-places of the Amphictyonic Council, and near it were held the Pythian games. The oracles were delivered by the mouth of a priestess who was seated on a tripod above a subterranean opening, whence she received the vapours ascending from beneath, and with them the inspiration of the Delphian god. The oracular replies were always obscure and ambiguous; yet they served, in earlier times, in the hands of the priests, to regulate and uphold the political, civil, and religious relations of Greece. The oracle was celebrated as early as the 9th century B.C., and continued to have importance till long after the Christian era, being at last abolished by the emperor Theodosius. Persons came to consult it from all quarters, bestowing rich gifts in return. The splendid temple thus possessed immense treasures, and the city was adorned with numerous statues and other works of art. It first lost its treasures in 357 B.C., when seized by the Phocians; it was afterwards plundered by Sulla and by Nero, while Constantine also removed several of its treasures. The site of the town is now occupied by a village called *Castri*, near which may be seen the still-flowing Castalian spring.

Delphin Classics, a collection of the Latin classic authors made for the dauphin (Lat. *ad usum Delphini*), son of Louis XIV., under the editorship of Bossuet and Huet, with notes and interpretations. A similar series based on these was published in London.

Delphin'idæ, the dolphin family of cetaceans. See *Dolphin*.

Delphin'ium, a genus of Ranunculaceæ, comprising the larkspurs, stavesacre, &c. See *Larkspur*.

Delta, the name of the Greek letter Δ, answering to the English D. The island formed by the alluvial deposits between the mouths of the Nile, from its resemblance to

this letter, was named Delta by the Greeks; and the same name has since been extended to those alluvial tracts at the mouths of great rivers which, like the Nile, empty themselves into the sea by two or more diverging branches.

Del'toid Muscle, a muscle of the shoulder which moves the arm forward, upward, and backward.

Deluc (dè-lük), JEAN ANDRÉ, a geologist and meteorologist, was born in 1726 at Geneva, died at Windsor 1817. In 1773 he came to England; was elected a fellow of the Royal Society of London, and appointed reader to the queen, a situation he held for forty-four years. He made numerous geological excursions in Central Europe and in England, of which he has published accounts. He aimed at defending the Mosaic account of the creation against the criticism whose weapons were furnished by his favourite science. He made many valuable original experiments in meteorology. Among his numerous writings are his *Recherches sur les Modifications de l'Atmosphère* (Geneva, 1772); *Nouvelles Idées sur la Météorologie* (London, 1786); and his *Traité élémentaire de Géologie* (Paris, 1810).

Del'uge, the universal inundation which, according to the Mosaic history, took place to punish the great iniquity of mankind. It was produced, according to Genesis, by a rain of forty days; and covered the earth 15 cubits above the tops of the highest mountains, and killed every living creature except Noah, with his family, and the animals which entered the ark by the command of God. Many other nations mention, in the mythological or prehistoric part of their history, inundations which, in their essential particulars, agree with the Scriptural account of Noah's preservation, each nation localizing the chief events and actors as connected with itself.

Delun'dung (*Prionodon gracilis*), a pretty quadruped inhabiting Java and Malacca, allied to the civets, and probably forming a connecting link between them and the Felidæ, being destitute of scent-pouches. It is of slender form, with a long tail, and is beautifully spotted.

Delvi'no, a town of Albania, about 44 miles north-west of Janina; it is the seat of a Greek bishop, and has some trade in olive-oil. Pop. about 8000.

Demagogue (dem'a-gog), originally simply **one** who leads or directs the people in poli-

tical matters; now it usually means one who acquires influence with the populace by pandering to their prejudices or playing on their ignorance.

Demand and Supply, terms used in political economy to express the relations between consumption and production, between the demand of purchasers and the supply of commodities by those who have them to sell. The relations which subsist between the demand for an article and its supply determine its price or exchangeable value. When the demand for a commodity exceeds the supply the price of the commodity is raised, and when the supply exceeds the demand the price falls.

Demavend (de-mä'vend), a volcanic mountain of Persia, and the highest peak of the Elbruz chain, 45 miles south of the Caspian Sea and about 40 miles N.E. of Teheran. Its height is about 19,400 feet, and it bears evidence of having been active during the latest geological (if not within the historic) period.

Dem'bea, or TSANA, a lake of Abyssinia, in a province of the same name in the west part of that country. It is of irregular form, about 140 miles in circumference, has an elevation of 6100 feet above the sea, and forms the reservoir of the Blue Nile.

Dembin'ski, HENRYK, a Polish general, and leader in the Hungarian revolution of 1849; born in 1791, died in 1864. He served under Napoleon during the Russian campaign of 1812; was governor of Warsaw and commander-in-chief of the Polish army during the revolution of 1830; was appointed by Kossuth commander of the Hungarian troops in 1849, and served till Kossuth's resignation compelled him to seek refuge in France, where he remained till his death.

Demen'tia, a form of insanity in which unconnected and imperfectly defined ideas chase each other rapidly through the mind, the powers of continued attention and reflection being lost. It often implies such general feebleness of the mental faculties as may occur in old age.

Demera'ra, or DEMARARA, a division of British Guiana, which derives its name from the river Demarara or Demerara. It extends about 100 miles along the coast, lying on the east of Essequibo and on the west of Berbice. The soil is very fertile, producing abundant crops of sugar, coffee, cotton, rice, &c. Chief town, Georgetown. Pop. of province, 125,000.—The river, after

a course of about 120 miles, flows into the Atlantic.

Demesne (de-mān'), or DOMAIN, in law, a manor-house and the land adjacent or near, which a lord keeps in his own hands or immediate occupation, for the use of his family, as distinguished from his tenemental lands, distributed among his tenants.

Dēme'ter, one of the twelve principal Grecian deities, the great mother-goddess, the nourishing and fertilizing principle of nature. She was the daughter of Cronus and Rhea, and mother of Persephōnē (Proserpine). The main feature in the myth of Demeter, and that which forms the fundamental idea of her worship, is the loss and recovery of her daughter, Persephōnē. By the Romans she was called *Ceres*. See *Ceres*.

Demet'rius, or DMITRI, the name of a series of impostors who usurped supreme authority in Russia, and led to some of its remarkable revolutions. Ivan Vasilievitch, who had put his eldest son to death with his own hand, left the throne in 1584 to another son, Fedor, a feeble prince, whom Boris Godunoff entirely supplanted in his authority. Ivan had left another son, Dmitri, by a second marriage; and Boris, fearing that he might one day prove a formidable obstacle to his ambitious projects, made away with him, but no one exactly knew how. Grishka, or Gregory Otrepieff, a native of Jaroslav and a novice in a monastery, personated Dmitri, went to Lithuania, where he embraced the Roman Catholic religion and married the daughter of Mniszek, palatine or waiwod of Sandomir. In 1604 he entered Russia at the head of a body of Poles, was joined by a number of Russians and Cossacks, and defeated an army sent against him. On the death of Boris he was placed on the throne, but he offended the Russians by his attachment to Polish manners and customs, and still more by a want of respect to the Greek religion and its patriarch, and he was assassinated after reigning about eleven months. A rumour of his being still alive having spread, another impostor quickly appeared to personify him, and the Poles espousing the cause of the second false Dmitri, made it triumphant, until he was assassinated in 1610 by the Tartars whom he had selected as his body-guards. A state of anarchy ensued and continued for nearly half a century, during which a number of other false Dmitri appeared in different quarters.

Demet'rius, surnamed *Poliorcētes* (the besieger of cities), king of ancient Macedonia, son of Antigonus a successor of Alexander the Great, was born about B.C. 339. Being sent by his father to wrest Greece from Cassander, he appeared before Athens with a fleet, expelled the governor Demetrius Phalereus, and restored to the people their ancient form of government (307 B.C.). He conquered Macedonia (294 B.C.) and reigned seven years, but lost this country, was imprisoned by Seleucus, and died in Syria 283 B.C.

Demetrius Phalereus (fa-lē'rūs), a celebrated Greek orator and statesman, born 345 B.C., in 317 was made Macedonian governor of Athens, and embellished the city by magnificent edifices. He fled to Egypt when Athens was taken by Demetrius Poliorcetes (see above), where he is said to have promoted the establishment of the Alexandrian Library and of the museum. Demetrius wrote on several subjects of philosophical and political science, but the work on rhetoric, which has come to us under his name, belongs to a later age.

Demi-lune, in fortification, practically the same as a ravelin (which see).

Demi-monde, an expression first used by the younger Dumas in a drama of the same name (first performed in 1855), to denote that class of gay female adventurers who are only half-acknowledged in society; popularly, disreputable femalesociety; courtezans.

Demi-rilievo (-ri-li-ā'vō), in sculpture, half-relief, or the condition of a figure when it rises from the plane as if it had been cut in two and only one half fixed to the plane.

Demise' (literally, 'a laying down'), in law, a grant by lease; it is applied to an estate either in fee-simple, fee-tail, or for a term of life or years. As applied to the crown of England, *demise* signifies its transmission to the next heir on being laid down by the sovereign at death.

Demisemiquaver, in music, half a semi-quaver, or the thirty-second part of a semi-breve.

Dem'iurge (Greek, *dēmiourgos*, a handicraftsman), a designation applied by Plato and other philosophers to the Divine Being, considered as the Architect or Creator of the universe. The Gnostics made a distinction between the Demiurge and the Supreme Being; with them the first is the Jehovah of the Jews, who, though deserving to be honoured as the Creator, was only the instrument of the Most High.

Demmin, an old town of Prussia, province of Pomerania, 70 miles w.n.w. from Stettin, with manufactures of woollen and linen cloth, hats, leather, hosiery, and tobacco; and a good trade. Pop. 10,507.

Democ'racy, the rule of a people by the people themselves; that form of government in which the sovereignty of the state is vested in the people, and exercised by them either directly, as in the small republics of ancient Greece, or indirectly, by means of representative institutions, as in the constitutional states of modern times. The term is also applied in a collective sense to the people or populace, especially the populace regarded as rulers. See also next art.

Dem'ocrat, one who adheres to democracy. In the U. States, a member of one of the two great political parties into which that country is divided; opposed to *Republican*. The main features of their system of principles are decentralization and self-government of the states.

Democ'ritus, a Greek philosopher of the new Eleatic school, a native of Abdēra, who was born between 470 and 460 B.C. He travelled to Egypt, where he studied geometry, and probably visited other countries, to extend his knowledge of nature. Among the Greek philosophers he enjoyed the instruction of Leucippus. He afterwards returned to his native city, where he was placed at the head of public affairs. Indignant at the follies of the Abderites, he resigned his office and retired to solitude, to devote himself exclusively to philosophical studies. According to later biographers he was called 'the laughing philosopher,' from his habit of laughing at the follies of mankind. In his system he developed still further the mechanical or atomical theory of his master Leucippus. Thus he explained the origin of the world by the eternal motion of an infinite number of invisible and indivisible bodies or atoms, which differ from one another in form, position, and arrangement, and which have a primary motion, which brings them into contact, and forms innumerable combinations, the result of which is seen in the productions and phenomena of nature. In this way the universe was formed, fortuitously, without the interposition of a First Cause. The eternal existence of atoms (of matter in general) he inferred from the consideration that time could be conceived only as eternal and without beginning. He applied his atomical theory, also, to natural

philosophy and astronomy. Even the gods he considered to have arisen from atoms, and to be perishable like the rest of things existing. In his ethical philosophy Democritus considered the acquisition of peace of mind as the highest aim of existence. He is said to have written a great deal; but nothing has come to us except a few fragments. He died 370 B.C., at an advanced age. His school was supplanted by that of Epicurus.

Demogor'gon, a mysterious divinity in pagan mythology, viewed as an object of terror rather than of worship, by some regarded as the author of creation, and by others as a famous magician, to whose spell all the inhabitants of Hades were subjected.

Demoiselle (dem-wä-zel'), the Numidian crane (*Anthropoides virgo*), an African bird which visits the south of Europe. It is about 3 feet in length, and differs from the true cranes in having the head and neck quite feathered and the tertials of the wings elongated and hanging over the tail. It has its name from its gracefulness and symmetry of form.

Demoivre (dè-mwä-vr), ABRAHAM, a French mathematician, born in 1667, died in London 1754. He settled in London after the revocation of the edict of Nantes, and gained a livelihood by becoming a teacher of mathematics. His chief works are: *Miscellanea Analytica*; *The Doctrine of Chances*, or a Method of Calculating the Probabilities of Events at Play; and a work on Annuities; besides Papers in the Transactions of the Royal Society, of which he was a fellow.

De'mon (Greek, *daimōn*), a spirit or immaterial being of supernatural but limited powers, especially an evil or malignant spirit. Among the ancient Greeks the name was given to beings similar to those spiritual existences called angels in the Bible. In the New Testament evil spirits are called demons (commonly translated 'devils'). A belief in demons is found in the oldest religions of the East. Buddhism reckons six classes of beings in the universe: two, gods and men, are accounted good; the other four are malignant spirits. The Persians and the Egyptians had also a complete system of demons; and in Europe, up till the middle ages, the divinities of oriental, classical, and Scandinavian mythology often figure, from the Christian point of view, as evil spirits. In later times phases of demon-

ology may be seen in the witchcraft mania and the spiritualism of the present day.

Demo'niac, a person whose mental faculties are overpowered, and whose body is possessed and actuated by some created spiritual being; especially a person possessed of or controlled by evil spirits. The New Testament has many narratives of demoniacs, and various opinions are entertained in regard to the character of their affliction.

Demonol'ogy, the doctrine or science which treats of the nature or character of demons or evil spirits.

Demonstration, in a logical sense, any mode of connecting a conclusion with its premises, or an effect with its cause. In a more rigorous sense it is applied only to those modes of proof in which the conclusion necessarily follows from the premises. In ordinary language, however, demonstration is often used as synonymous with *proof*.

Demon'te, a town, North Italy, on the Stura, 14 miles s.w. from Cuneo. Pop. over 6000.

De Morgan, AUGUSTUS, mathematician and logician, was born at Madura, in Southern India, 1806, died 1871. He was educated at Cambridge, gaining the fourth place in the mathematical tripos in 1827. The following year he was appointed professor of mathematics in the University College, or, as it was then called, London University—a situation which he held until 1866, with the exception of the five years from 1831 to 1836. His writings are very numerous, and include Elements of Arithmetic; Elements of Algebra, Elements of Trigonometry; Essay on Probabilities and on their Application to Life Contingencies and Insurance Offices; Formal Logic. Professor De Morgan was an extensive contributor to the Penny Cyclopædia and to several leading periodicals of the time.

De'mos (Greek), the people as a whole, or the body of people of the lower class as distinguished from those of rank, wealth, or position.

Demos'thenes (-nēz), the famous ancient Greek orator, was the son of a sword-cutler at Athens, where he was born in 382 (according to some in 385) B.C. His father left him a considerable fortune, of which his guardians attempted to defraud him. Demosthenes, at the age of seventeen years, conducted a suit against them himself, and gained his cause. He then set himself to study eloquence, and though his lungs were weak, his articulation defective, and his ges-

tures awkward, by perseverance he at length surpassed all other orators in power and grace. He thundered against Philip of Macedon in his orations known as the *Philippics*, and endeavoured to instil into his fellow-citizens the hatred which animated his own bosom. He laboured to get all the Greeks to combine against the encroachments of Philip, but their want of patriotism and Macedonian gold frustrated his efforts. He was present at the battle of Chæroneia (380 B.C.), in which the Athenians and Bœotians were defeated by Philip, and Greek liberty crushed. On the accession of Alexander in 336 Demosthenes tried to stir up a general rising against the Macedonians, but Alexander at once adopted measures of extreme severity, and Athens sued for mercy. It was with difficulty that Demosthenes escaped being delivered up to the conqueror. In 324 he was imprisoned on a false charge of having received a bribe from one of Alexander's generals, but managed to escape into exile. On the death of Alexander next year he was recalled, but the defeat of the Greeks by Antipater caused him to seek refuge in the temple of Poseidon, in the island of Calauria, on the coast of Greece, where he poisoned himself to escape from the emissaries of Antipater (322 B.C.). The character of Demosthenes is by most modern scholars considered almost spotless. His fame as an orator is equal to that of Homer as a poet. Cicero pronounces him to be the most perfect of all orators. He carried Greek prose to a degree of perfection which it never before had reached. Everything in his speeches is natural, vigorous, concise, symmetrical. We have under his name sixty-one orations, some of which are not genuine. The great opponent—and indeed enemy—of Demosthenes as an orator was Æschines.

Demot'ic (or ENCHORIAL) **Alphabet**, a simplification of the hieratic, which again was a contraction of the hieroglyphic characters. See *Hieroglyphic Writing*.

Demot'icos, or DIMOTIKA, a town, Turkey in Europe, Roumelia, on the right bank of the Maritza, 20 miles south from Adrianople; the see of a Greek archbishop; pop. about 8000.

Dempster, THOMAS, a learned Scotsman, born in Aberdeenshire 1579, died at Bologna 1625. He was educated at Aberdeen and Cambridge; went to France at an early period of life, and became a professor in the College of Beauvais. He ultimately

held professors' chairs at Nismes, Pisa, and at Bologna, where he died. His works are very numerous. Among them his *Historia Ecclesiastica Gentis Scotorum* is the most remarkable, though, instead of being, as its title would indicate, an ecclesiastical history of Scotland, it is merely a list of Scottish authors and Scottish saints, many of whom are fictitious. His really most valuable work is *De Etruria Regali*.

Demul'cents, medicines which tend to soothe or protect the mucous membranes against irritants. They are generally composed of starch, gum, albuminous or oily substances largely diluted.

Demurr'age, in maritime law, the time during which a vessel is detained by the freighter, beyond that originally stipulated, in loading or unloading. When a vessel is thus detained she is said to be *on demurrage*. The name is also given to the compensation which the freighter has to pay for such delay or detention. Demurrage must be paid though it be proved the delay is inevitable; but it cannot be claimed where it arises from detention by an enemy, tempestuous weather, or through the fault of the owner, captain, or crew. The term is applied also to detention of railway wagons, &c.

Demurrer, in law, a stop at some point in the pleadings, and a resting of the decision of the cause on that point; an issue on matter of law. A demurrer confesses the fact or facts to be true, but denies the sufficiency of the facts in point of law to support the claim or defence.

Demy', a size of paper intervening between royal and crown. Printing demy measures generally 22 inches by 17½, writing 20 inches by 15½, drawing 22 inches by 17.

Denain (dè-nan), a town of Northern France, dep. Nord, 6 miles from Valenciennes. It stands in the centre of a coal-field, and has iron-works, &c. A great victory was gained here in 1712 by the French under Villars over the allies under Eugene and Albemarle. Pop. 15,734.

Dena'rius, a Roman silver coin worth 10 asses or 10 lbs. of copper originally, and afterwards considered equal to 16 asses, when the weight of the as was reduced to an ounce on account of the scarcity of silver. The *denarius* was equivalent to about 7¾d. English money. There was also a gold denarius equal in value to 25 silver ones.

Denbigh (den'bi), a county of North Wales, on the Irish Sea; area, 392,005 acres, of which about a fourth is arable.

Along the N. the ground is level, in the E. hilly, while the mountains in the S. and W. rise from 1000 to 2500 feet. There are several beautiful and fertile vales, amongst the more celebrated of which are the vales of Llangollen, Clwyd, and Conway. Bar-

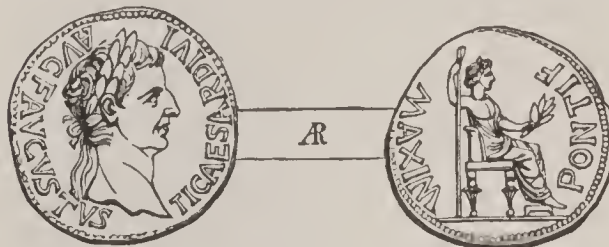

Denarius of Tiberius Cæsar.

ley, oats, and potatoes are grown on the uplands; and in the rich valleys wheat, beans, and pease. Cattle and sheep are reared, and dairy husbandry is carried on to a considerable extent. The minerals consist of lead, iron, coal, freestone, slate, and millstone. Flannels, coarse cloths, and stockings are manufactured. The principal rivers are the Clwyd, the Dee, and the Conway. For parliamentary purposes it is divided into two divisions, one member for each. Pop. 111,470.—The county town Denbigh is a municipal and parliamentary borough near the centre of the Vale of Clwyd, 25 miles W. of Chester, picturesquely situated on a rocky eminence, the summit of which is crowned by the ruins of an ancient castle. Tanning and shoemaking are carried on. It sends one member to parliament in conjunction with Holt, Ruthin, and Wrexham. Pop. 6535.

Den'derah (the *Tentyra* of the Greeks and Romans), an Arab village of Upper Egypt, on the left bank of the Nile, 28 miles N. of Thebes, celebrated for its temple dedicated to Athor, the Egyptian Venus, the best preserved of any of the great temples of antiquity in Egypt.

Dendermon'de, or **TERMONDE**, a town, Belgium, province of East Flanders, at the confluence of the Dender with the Scheldt, 12 miles N.W. from Brussels. It is strongly fortified, defended by a citadel, and surrounded by low marshy ground which can be laid under water. Manufactures woollens, linens, tobacco, &c. The town was taken by Marlborough in 1706. Pop. 8462.

Den'drite, a stone or mineral, on or in which are figures resembling shrubs, trees, or mosses. The appearance is due to arborescent crystallization, resembling the frost-work on our windows. The figures gener-

ally appear on the surfaces of fissures and in joints in rocks, and are attributable to the presence of the hydrous oxide of manganese, which generally assumes such a form.

Dendro'bium, an extensive genus of epiphytes dispersed over the damp tropical forests of Asia, order Orchidaceæ. They vary much in habit; many are cultivated in hothouses on account of the beauty of their flowers.

Den'drophis, a genus of harmless serpents, family Colubridæ, found in India and Africa, living on trees and feeding on reptiles.

Dengue (deng'gā), a febrile epidemic disease of the West Indies and southern United States of America, the symptoms of which are such as would accompany a mixture of scarlet fever and rheumatism.

Den'ham, DIXON, lieutenant-colonel, African traveller, was born at London in 1786, died at Sierra Leone 1828. In 1823-24 he was engaged, in company with Captain Clapperton and Dr. Oudney, in exploring the central regions of Africa. Denham himself explored the region around Lake Tchad, was wounded and separated from his company, but found his way home after great suffering, when he published his Narrative of Travels. In 1826 he went to Sierra Leone as superintendent of the liberated Africans, and in 1828 was appointed lieutenant-governor of the colony.

Denham, SIR JOHN, a poet, born at Dublin in 1615, died 1689, and was buried in Westminster Abbey. In 1641 he first became known by his tragedy of *The Sophy*, and in 1642 he published the first edition of his most celebrated poem, called *Cooper's Hill*. He was subsequently intrusted with several confidential missions by the royalist party, and, being detected, fled to France. At the restoration in 1660 he obtained the office of surveyor of the king's buildings, and was created a knight of the Bath, and a fellow of the newly-formed Royal Society.

Deni'na, CARLO GIOVANNI MARIA, an Italian historian, born in 1731 at Revello, in Piedmont. He became professor at Pinerolo, and afterwards at Turin, where he published the three first volumes of his *History of Italian Revolutions* (1769), containing a general history of Italy. In 1777 he went to Rome, and four years later to Berlin, where he was welcomed by Frederick the Great, an account of whose life and reign he afterwards wrote. Most of his

works—*History of Piedmont*, *Political and Literary History of Greece*, &c.—were written at Berlin. In 1804 he was introduced to Napoleon, who appointed him imperial librarian at Paris. He died in 1813.

Denis (Latin, *Dionysius*), ST., the apostle of the Gauls. He set out from Rome on his sacred mission towards the middle of the 3d century, became the first Bishop of Paris, and was put to death by the Roman governor Pescennius. Catulla, a heathen lady converted by the sight of the saint's piety and sufferings, had his body buried in her garden, where the Abbey of St. Denis now stands.

Denis, ST., a town in France, department of the Seine, 6 miles north of Paris, lying within the lines of forts surrounding the capital. It contains the famous abbey church of St. Denis, a noble Gothic structure in part dating from the 11th century or earlier, but much has been done in the way of restoration in the present century. St. Denis was the burial-place of the kings of France; and all her rulers from Hugh Capet downwards, besides some of the earlier dynasties, lay there till 1793, when the revolutionary fury of the convention caused the tombs to be rifled and the church to be denuded. At the restoration Louis XVIII. again sought out the relics of his ancestors as far as they could be found, and had them buried here, and there is now again a long series of restored royal tombs, with numerous other monuments, much stained glass, and modern decoration. The church is about 354 feet long and 92 high. Pop. 1891, 50,992.

Denison, Grayson co., Tex., 73 miles N. of Dallas. Pop. 1890, 10,959.

Den'izen, in English law, an alien who is made a subject by the sovereign's letters patent, holding a middle state between an alien and a natural born subject. A denizen cannot sit in either house of parliament or hold any civil or military office of trust.

Den'mark, a northern kingdom of Europe, consisting of a peninsular portion called Jutland, and an extensive archipelago lying east of it and comprising the islands of Seeland (or Sjælland), Fünen (or Fyen), Lolland (or Lolland), Falster, Langeland, Møen, Samsø, Lasø, Arrø, Bornholm, and many smaller ones. Besides these there are the outlying possessions of Iceland, Greenland, and the Faroe islands in the Atlantic Ocean, and Santa Cruz, St. Thomas, and St. John in the West Indies. The area of the home possessions is 14,789 sq. miles (barely

DENMARK.

half that of Scotland), of which Jutland occupies 9755; the pop. in 1880 was 1,980,259; in 1890, 2,172,205. Including Iceland, part of Greenland, &c., the total area of the Danish possessions is 101,403 sq. miles; pop. 2,288,193. Copenhagen is the capital; other chief towns are Odense, Aarhus, Aalborg, Randers, and Horsens. For administrative purposes Denmark is divided into eighteen provinces or districts, besides the capital, nine of these making up Jutland, while the others embrace the islands.

On the south Denmark is bounded by Germany and the Baltic; on the west it is washed by the North Sea; northwards it is separated from Norway by the Skagerrack; eastward it is separated from Sweden by the Kattegat and the Sound. Denmark, whether insular or mainland, is a very low-lying country, the eastern side of Jutland, where the highest elevation occurs, not exceeding 550 feet. All the rocks belong to the upper series of the secondary and to the tertiary formation. The rock most fully developed is the chalk, above which is an extensive boulder formation containing seams of lignite. Above this are thick beds of clay and marl. Where this prevails, as in Seeland and the east of Jutland, the soil is generally fertile; but where it is overlaid with deep beds of sand, as in the north and west of Jutland, the aspect is extremely desolate. Nearly the whole west coast, indeed, is rendered almost uninhabitable by the drift-sand which has formed an almost uninterrupted line of sterile downs called *Klitten*, extending from Cape Skagen (or The Skaw) to Blaavands Hook. A large portion of Jutland consists of heathy or moory land, comparatively unprofitable. Elsewhere it exhibits a fertile undulating surface. The islands, especially Seeland and Funen, are fertile and present many landscape beauties. The country was once covered with great forests, but these have disappeared, and Denmark is largely dependent on other countries for her supplies of timber. Woods of some extent still exist, however, especially in the islands. In earliest prehistoric times (the stone age) the Scotch fir was the prevailing tree, and subsequently the oak. The principal tree now is the beech, the oak forming but a small portion of the timber of Denmark. The elm, ash, willow, aspen, and birch are met with in small numbers or singly. Pine forests have been planted in the north of Jutland and elsewhere. Denmark has nu-

merous streams but no large rivers; the principal is the Guden, which flows north-east through Jutland into the Cattegat. It is navigable for part of its course. Less important streams are the Holm, the Lonborg, and the Stor Aa. All the others are insignificant brooks and streamlets. The lakes are very numerous but not large, none exceeding $5\frac{1}{2}$ miles in length by about $1\frac{1}{2}$ mile broad. There are numerous winding



Danish Mansion—Castle on the Island of Funen.

inlets of the sea that penetrate far into the land. The largest of these, the Liimfiord in Jutland, entering from the Cattegat by a narrow channel, winds its way through to the North Sea, thus making northern Jutland really an island. In this fiord, which widens out greatly in the interior and gives off various minor fiords, there are one large and various small islands. Intercourse between the various islands and parts of the kingdom, separated from each other by water, is well kept up by ferries, &c., and the country is well supplied with railways both in Jutland and the islands. Copenhagen, Aalborg, Aarhus, and Randers are the chief seaports. Owing to the lowness of the land and its proximity to the sea on all sides, the climate is remarkably temperate for so northerly a region, though the thermometer in winter may sink to 22° below zero, and in summer rise to 89° . Violent winds are frequent, and rains and fogs prevalent, but the climate is favourable to vegetation.

DENMARK.

The agricultural land is greatly subdivided, as the law interdicts the union of small farms into larger. Among crops the greatest area is occupied by oats, which are grown all over the country, but best in Jutland. Barley is grown chiefly in Seeland, and is largely used in brewing beer, the common beverage of the country. Rye is extensively raised, and the greater part of the bread used in Denmark is made from it. Turnips, beans, pease, flax, hemp, hops, tobacco, &c., are also grown; but in general cattle-breeding, grazing, and the dairy take up most of the farmer's attention in Denmark. The old Danish breed of horses, found chiefly in Jutland, has long been famous for strength, symmetry, docility, and bottom. The fisheries are still important, but not so much as formerly. The herring, turbot, torsk, and salmon are the most abundant. The manufactures, although progressing, are not yet of great importance. Paper, gloves, the woollens and earthenware of Jutland, the wooden clocks of Bornholm, are the chief. There are also iron-foundries, sugar-refineries, some extensive tanneries, and many distilleries. The people of Denmark bake their own bread, brew their own beer, and make the greater part of their house furniture and utensils with their own hands.

The commerce of Denmark is carried on chiefly with Great Britain, Germany, Norway, Sweden, and Russia, Germany possessing the largest share, and Great Britain coming a little behind her. The value of imports has in recent years varied between \$65,000,000 and \$80,000,000. The chief imports are textile manufactures, metal goods, coal, timber, oil, coffee, sugar, tobacco, fruit, &c. The chief exports are cattle, horses, and swine, butter (a most important item), bacon, hides, flour, eggs, and other edibles. Much of the butter and other agricultural produce goes to Britain. In 1892 the mercantile marine had a total tonnage of about 310,952 tons. The railways have a length of about 1200 miles. Since 1875 the unit of the Danish monetary system has been the *krone*, or crown, equal to 1s. 1½d., or $\frac{1}{18}$ th of a pound sterling. The *krone* is divided into 100 *öre*. The Danish pound weight is equal to 1.102 avoirdupois. The *barrel* or *toende*, the principal measure in Denmark, is equal to 3.8 imperial bushels; the *viertel*, used for wine and liquor, to 1.7 English gallon. The *foot* equals 12.356 English inches; the *mile* is 4.684 English miles.

The population of Denmark is composed almost exclusively of Danes, with a few thousand Jews and others. The Danes have regular features, fair or brownish hair, and blue eyes. They still maintain their reputation for seafaring skill and hospitable customs. They are almost exclusively Lutherans in religion, but unlimited toleration is extended to all faiths. Jews, however, though themselves electors, cannot be elected as representatives. At the head of the educational institutions stand the University of Copenhagen and the Holberg Academy at Sorøe. The provinces are well supplied with gymnasia and middle schools, and primary instruction is given at the public expense in the parochial schools. It is rare to meet a peasant who cannot read and write even amongst the poorer class.

The government of Denmark was originally an elective monarchy. In 1661 it became a hereditary and absolute monarchy, and in 1849 a hereditary constitutional one, the legislative power being in the king and diet jointly. The diet or *Rigsdag* consists of two chambers, the *Landsting* or upper house, the *Folkething* or lower house. The former is a senate of 66 members, twelve of whom are nominated for life by the crown, the others being elected for eight years. The members of the Folkething are 102 in number, directly elected by universal suffrage, and hold their seats for three years. The Rigsdag meets every October, and all money bills must be submitted to the lower house. The army consists of all the able-bodied young men of the kingdom who have arrived at the age of twenty-one years. The time of service is eight years in the regular troops, and afterwards eight more in the reserve. Every corps has to drill for thirty to forty-five days every year. The army on a war footing has a total strength of about 75,000 men. The navy consists of 45 vessels and 135 guns. The revenue usually amounts to about \$15,000,000. The national debt is \$33,004,722.

History.—The oldest inhabitants of Denmark whom we find mentioned by name were the Cimbric, who dwelt in the peninsula of Jutland, the *Chersonesus Cimbrica* of the Romans. They first struck terror into the Romans by their incursion, with the Teutones, into the rich provinces of Gaul (113–101 B.C.). After this, led by the mysterious Odin, the Goths broke into Scandinavia, and appointed chiefs from their own nation over Denmark, Norway, and Sweden. For

a considerable time Denmark was divided into a number of small states, whose inhabitants lived mostly by piracy along the neighbouring coasts. In 787 they began to make their descents on the eastern coasts of England, and along with other inhabitants of Scandinavia they conquered Normandy in 876-7. Under Gorm the Old all the small Danish states were united in 920, and his grandson Sweyn, now the head of a powerful kingdom, commenced the conquest of Norway and of England, which was ultimately completed by his son Canute. Canute died in 1035, leaving a powerful kingdom to his successors, who, in 1042, lost England, and in 1047 Norway. In 1047 Sweyn Magnus Estridsen ascended the throne, but with the exception of the great Waldemar the new dynasty furnished no worthy ruler, and the power of the kingdom decayed considerably till the accession of the politic Queen Margaret in 1387, who established the union of Calmar in 1397, uniting under her rule Denmark, Sweden, and Norway. In 1448 Christian I., count of Oldenburg, was elected to the throne, thus founding the royal family of Oldenburg, which kept possession of the throne till 1863. Under the rule of Christian, Norway, Sweden, Schleswig, and Holstein were connected with the crown of Denmark, but under his successor Christian II. Sweden established its independence. Under Frederick I. (1523-33) the Reformation was introduced. Christian IV. of Denmark ascended the throne in 1588, took part in the Thirty Years' war, and engaged twice in a war with Sweden, with most unfortunate results. Frederick III. again engaging in war with Sweden in 1657 was equally unsuccessful. Christian V. and Frederick IV. were conquered in the war with Charles XII. Denmark, however, after the fall of Charles XII., gained by the Peace of 1720 the toll on the Sound, and maintained possession of Schleswig. After this Denmark enjoyed a long repose. In 1800, having acceded to the northern confederacy, the kingdom was involved in a war with Great Britain, in which the Danish fleet was defeated at Copenhagen April 2, 1801. In 1807, there being reason to think that Denmark would join the alliance with France, a British fleet was sent up the Sound to demand a defensive alliance or the surrender of the Danish fleet as a pledge of neutrality. Both were denied, till the Danish capital was bombarded and forced to capitulate, the

whole fleet being delivered up to the British. The war, however, was continued, Denmark forming new alliances with Napoleon till 1814, when a peace was concluded by which she ceded Heligoland to England in exchange for the Danish West India Islands, and Norway to Sweden in exchange for Swedish Pomerania and Rügen, which, however, she shortly after surrendered to Prussia, receiving in return Lauenburg and a pecuniary compensation. In June 1815 the king entered into the German confederacy as representing Holstein and Lauenburg. In 1848 Schleswig and Holstein revolted and were not finally subdued till 1852. In 1857 the Sound dues were abolished. Frederick VII. died in 1863 and with him the Oldenburg line became extinct. He was succeeded by Christian IX. (Prince of Sonderburg-Glücksburg). At the commencement of 1864 the Danish territory was politically distributed into four parts, viz. Denmark Proper (consisting of the Danish islands and North Jutland), the duchy of Schleswig or South Jutland, with a population more than one-half Danish, the remainder Frisian and German; the duchy of Holstein, purely German; the duchy of Lauenburg, also German. The measures of the Danish government compelling the use of the Danish language in state schools having given great umbrage to the German population of the duchies, the disputes resulted in the intervention of the German confederation, and ultimately Holstein was occupied by the troops of Austria and Prussia (1864). After a short campaign the Prussians captured Alsen, overran the greater part of Jutland, and forced the Danes to accept a peace (Aug. 1), by which they renounced their right to the duchies of Schleswig, Holstein, and Lauenburg. A difference now arose between Austria and Prussia as to what should be done with the duchies, and Prussia showing an evident intention of annexing them, the result was a war between the two powers, which ended in the total defeat of Austria at Sadowa, or Königgrätz, 3d July, 1866. By the treaty which followed Austria relinquished all claim to the duchies, which thus fell to Prussia. The chief events since then have been the prolonged struggle between the government and the Folkething; the celebration of the centenary of the emancipation of the Danish peasants (1888); and the jubilee of King Christian (1888).

Language and Literature.—The Danish

language belongs to the Scandinavian branch of the Teutonic family of languages, and is a sister of the Swedish and Norwegian. It is the most modern of the Scandinavian tongues; soft and rather monotonous, with shades of sound difficult for a foreigner to acquire. It is written either in the German or the Roman character. From the long union of Norway with Denmark, Danish became the written language of the Norwegians, and is still the language of the educated classes. The oldest literary monuments of the Danish language consist of the laws of the early kings in the 12th century. Next to these come the heroic ballads (*Kjämpeviser*), some of which date from the 13th, others from the 14th, 15th, and 16th centuries. They were collected while they still lived in the mouths of the people by A. S. Vedel. Other ancient literary monuments, probably belonging to the 13th century, are the Danish Rhyming Chronicle and a Danish translation of the Old Testament. During the Reformation period Christian Pedersen (1480–1554) did for the Danish language much what Luther did for the German, by publishing, besides other works, a translation of the New Testament and the Psalter and latterly the complete Bible. The 16th and 17th centuries were distinguished by the publication of a number of works on the national history, among the writers of which we may mention Hans Svaning the elder, Arild Hvitfeld, Nils Krag, Vitus Bering, Ramus, &c. Modern Danish poetry commences in the period succeeding the Reformation with hymns, Scriptural dramas, edifying narratives, &c. Justesen Raach and Erik Pontoppidan the elder are amongst the chief names in this department. Anders Bording (died 1677) and Thomas Kingo (died 1723) made names as lyric poets, the sacred poems of the latter being a noble contribution to Danish literature. A new epoch began with Louis Holberg (1684–1754), who was the founder of the Danish stage, and his name and that of the lyric and dramatic poet Ewald mark the brightest period of the national literature. Amongst the comic dramatists Peder Andreas Heiberg, and amongst song writers the celebrated Jens Baggesen hold the first place. Fresh life was inspired into Danish poetry by Adam Oehlenschläger (1779–1850), contemporary with whom was Adolf Wilhelm Schack Staffeldt (1770–1826), a lyric poet of the first rank. In 1811 Bernhard Severin Inge-

mann made his appearance, first as a lyric poet, but afterwards turned his attention to the drama, and later to the historic romance. Among dramatic writers the names of Johan Ludwig Heiberg, Overskou, Høstrup, Erik Bögh, and the more recent Mølbech, and Edvard Brandes, are well known. Among poets we may mention Heiberg, Andersen, Blicher, Hølst, Paludan-Müller, and Rosenhoff; the modern school being represented by Carl Ploug, Drachmann, and Gjellerup. Among those who have displayed a talent for novel-writing are Ch. Winther, Carl Bernhard, Meyer Aron Goldschmidt, Sten Stensen Blicher, who describes common life in Jutland with poetic truth. Amongst other distinguished modern writers we must mention Hendrik Hertz, a lyric poet and dramatist; Hans Christian Andersen, famous for his stories throughout Europe; and Waldemar Thisted, a lyricist and novel-writer of considerable note. Amongst scholars the names of Madvig, Westergaard, Rask, and others take a high place.

Dennewitz (*den'e-vits*), a small Prussian village in the circle of Potsdam, province of Brandenburg, famous for the battle between the French and Prussians, September 6, 1813, in which the latter, aided towards the end by Russian and Swedish armies, were victorious.

Dennis, JOHN, an English dramatist and critic, born in London in 1657. He was, to begin with, a man of independent means, and devoting himself to literature wrote some dramatic pieces and poems, and at length settled down to criticism. His irritability and rancorous criticisms involved him in perpetual broils. Pope gave him a place in his *Dunciad*, and Swift satirized him with merciless wit in his *Narrative of the Deplorable Frenzy of Mr. John Dennis*. Having fallen into poverty in his old age a play was given for his benefit, to which his former antagonist, Pope, contributed a prologue. He died January 6, 1734.

Denny, a town of Scotland, in Stirlingshire, on the south bank of the Carron, about 18 miles from Glasgow, having in or near it paper-mills, iron-works, engine-works, &c. Pop. 4081.

Denon (*dè-nōn*), **DOMINIQUE VIVANT, BARON DE**, a distinguished French artist, born 1747, of a noble family. Of amiable manners, and with a talent for the arts, he was appointed gentleman-in-ordinary to Louis XV. He was afterwards employed in the diplomatic service, and was long con-

nected with the French embassy in Naples, where he greatly improved his talent for drawing and engraving. Returning to France he became acquainted with Bonaparte, accompanied him in his campaigns, was made inspector-general of museums, selected the works of art to be transferred from conquered countries to the Louvre, and superintended the erection of monuments in honour of the French successes. He died at Paris in 1825. He published Travels in Upper and Lower Egypt, finely illustrated.

Dénouement (dā-nō-mān), a French term naturalized in England, and signifying the winding up or catastrophe of a plot, the solution of any mystery, &c.

Den'sity, in physics, the quantity of matter contained in a body under a given bulk. If a body of equal bulk with another contains double the quantity of matter it is of double the density. Or if a body contain the same quantity of matter as another, but under a less bulk, its density is greater in proportion as its bulk is less than that of the other. Hence the density is directly proportional to the quantity of matter, and inversely proportional to the bulk or magnitude. The relative quantities of matter in bodies are known by their gravity or weight, and when a body, mass, or quantity of matter is spoken of, its weight or gravity is always understood, that being the proper measure of the density or quantity of matter. The weights of different bodies, of equal bulks, indicate their relative densities. The density of solids, fluids, and gases, as compared with that of water, is their *Specific Gravity* (which see). As for the density of the earth see *Earth*.

Dental Formula, an arrangement of symbols and numbers used to signify the number and kinds of teeth of a mammiferous animal. The *dental formula* of man is: I. $\frac{2-2}{2-2}$, C. $\frac{1-1}{1-1}$, P.M. $\frac{2-2}{2-2}$, M. $\frac{3-3}{3-3} = 32$,

which is read thus: Two incisors on each side of both jaws, one canine tooth on each side of both jaws, two præmolars on each side of both jaws, and three true molars on each side of both jaws, in all 32 teeth.

Denta'lium, a genus of gasteropodous molluscs, the shell of which consists of a tubular arcuated cone open at both ends, and resembling the tusk of an elephant in miniature. There are many species, known by the common name of tooth-shells.

Denta'ria, coral-root, a genus of plants, nat. order Cruciferae. There are about

twenty species, natives of temperate countries. They are ornamental herbs, with creeping singularly toothed root-stocks, from which they receive the names of coral-root and tooth-wort. The stem-leaves are opposite or in whorls of three, and the flowers are large and purple. *D. bulbifera*, the only British species, is a rare plant in the south-east of England. *D. diphylla*, or pepperwort, a North American species, has roots that are used as mustard.

Denta'tus, MANIUS CURIUS, an ancient Roman general of Sabine descent. In B.C. 290 he brought to a victorious termination the war with the Samnites, which had lasted for nearly fifty years. In B.C. 275 he defeated King Pyrrhus at Beneventum, for which he received a magnificent triumph. In B.C. 274 he was made consul for the third time and conducted to a successful issue the last war with the southern Italians. He died about B.C. 270.

Den'tex, a genus of acanthopterygious fishes of the family of the Sparidæ, or seabreams. They have conical teeth, and those immediately in front are long and hooked inward. The *Dentex vulgāris*, common in the Mediterranean, sometimes attains the length of 3 feet. Its general appearance is not unlike the perch. It is esteemed as an article of food.

Den'tifrice, a preparation for cleaning the teeth, of which there are various kinds in the form of tooth-powders, tooth-washes, or tooth-pastes. Cuttle-fish bone, finely-powdered chalk, and charcoal are common dentifrices. Rhatany, catechu, myrrh, and mastic are also often employed.

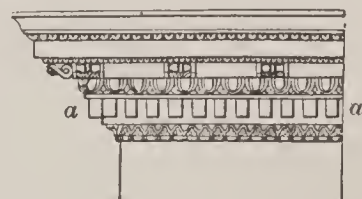

a a, Dentils of the Corinthian Cornice.

Den'tils, in arch., the little cubes resembling teeth, into which the square member in the bed-moulding of an Ionic, Corinthian, or Composite cornice is divided.

Den'tine, the ivory tissue lying below the enamel and constituting the body of a tooth. It consists of an organic basis disposed in the form of extremely minute tubes and cells, and of earthy particles.

Dentiros'tres, a tribe of birds of the order Insessores or Perchers, including Shrikes, Butcher-birds, &c., characterized by having a notch and tooth-like process on each side of the margin of the upper mandible. They are rapacious and prey on weaker birds.

Den'tistry, the art of cleaning and extracting teeth, of repairing them when diseased, and replacing them when necessary by artificial ones. There are two very distinct departments in dentistry, the one being *dental surgery*, the other what is known as *mechanical dentistry*. The first requires an extended medical knowledge on the part of the practitioner, as, for instance, a knowledge of diseases whose effects may reach the teeth, of the connection between the welfare of the teeth and the general system, &c., as well as ability to discern latent oral diseases, calculate the effects of operations, &c. The chief operations in this department are *scaling*, or removing the tartar which has accumulated on the base of the teeth; *regulating*, the restoring of overcrowded and displaced teeth to their proper position; *stopping* or *stuffing*, the filling up of the hollow of a decayed tooth and thus preventing the progress of decay; *extracting*, a process requiring considerable muscular power and delicacy of manipulation. The second department, mechanical dentistry, is concerned with the construction of artificial substitutes for lost teeth, and requires much mechanical science, it being a very delicate work to give artificial teeth a perfectly natural appearance in shape and colour. The actual construction of the teeth, however, has passed largely into the hands of the manufacturers, and the dentist has only the selecting, fitting, and fixing to do. Until recent years no special curriculum or collegiate certificate was obtainable by practitioners of dentistry in Great Britain. In 1858 the dental certificate of the College of Surgeons of England was established. In 1878 an act was passed regulating the education and registration of dentists. In the United States the Baltimore College of Dental Surgery is the oldest, being chartered in 1839; the Ohio College of Dental Surgery followed in 1845; the Philadelphia College of Surgery in 1850; the Philadelphia Dental College in 1863; the New York College of Dentistry in 1865, and various others. The *American Journal and Library of Dental Science* was established in Baltimore in 1839. Every State has now its State Dental Society; besides national organizations, of which the American Dental Association is among the most important.

Dentition. See *Teeth*, *Teething*.

D'Entrecasteaux (dān-tr-kas-tō'), a name of several applications in geography. (1) A

channel between the south-east cape of Tasmania and Bruni Island. It affords good shelter and anchorage to ships. (2) D'Entrecasteaux Isles, a group lying E. of British New Guinea. (3) D'Entrecasteaux Point, on the s.w. coast of Australia.

Denuda'tion, in geology, the act of washing away the surface of the earth by water, either in the form of constant currents or of occasional floods.

Den'ver, a city in the United States, capital of the state of Colorado, on the right bank of the South Platte River, 15 miles east of the Rocky Mountains. It is well built, having imposing public and other buildings, and is increasing with extraordinary rapidity, being the junction of eight important railway systems, and having various flourishing industries. The climate is peculiarly dry and salubrious. The town was founded in 1858. Pop. in 1880, 35,62; in 1889, 85,000; in 1890, 106,713.

Deob'struments, medicines which open the natural passages of the fluids of the body, as the pores and lacteal vessels, and thus cause removal of obstructions.

Deobund, or DEOBAND (dā-o-band'), a town of Hindustan, Sahárunpur district, N.W. Provinces, an ancient place with manufactures of fine cloth. Pop. 22,116.

De'odand (*Deo dandum*), a thing to be given or dedicated to God, an obsolete legal term for anything that had caused a person's death, all such chattels being forfeited by the old rule of the common law of England to the sovereign or lord of the manor. Its origin was attributed to the notion, that where a man was suddenly cut off in his sins expiation ought to be made for the benefit of his soul; and, accordingly, the chattel which occasioned his death should be forfeited to the king, to be devoted by him to pious uses. Deodands were abolished in 1846.

De'odar, DEODAR CEDAR, or INDIAN CEDAR (*Cedrus Deodāra*), a large and valuable Indian tree similar to the cedar of Lebanon, and by some considered only a variety. It inhabits the Himalayas and yields timber that is much used in Hindustan. It was introduced into Britain in 1831, and is now a common ornamental tree. See *Cedar*.

Deodori'zers, chemical substances which have the power of destroying fetid effluvia, as chlorine, chloride of lime, &c.

Deogarh (dā-o-gar'), the name of two towns in Hindustan: (1) In Bengal, 170

miles N.W. of Calcutta, with a group of temples to which numerous pilgrims resort. Pop. 8005. (2) In Oodeypore Rajputana. Pop. 6846.

Deogiri (dā'o-gi-ri). See *Daulatabad*.

D'Éon de Beaumont (dā-on də bō-mōn), CHARLES GENEVIÈVE LOUISE AUGUSTE ANDRÉ TIMOTHÉE, a notorious French character, chevalier, doctor of law, diplomatist, &c., born in 1728. In 1755 he was sent as envoy on a difficult mission to the Russian court, on which occasion he seems to have dressed himself as a woman. He afterwards distinguished himself in the Seven Years' war, then went to London as secretary of the French legation, and ultimately became minister plenipotentiary. Having quarrelled with the French government he lived fourteen years in London in a kind of banishment. During these years he had occasionally, probably for purposes of intrigue, dressed and passed as a female, and about this time his sex began to be doubted. In 1777 he returned to France, was ordered to dress as a woman, and continued to do so both there and after he returned to England (in 1785), where he died in great poverty in 1810, being then regarded by everyone as a female.

Deontol'ogy, the science of duty; the term is used by certain philosophic schools (Bentham, Spencer, &c.) to denote their doctrine of ethics.

Department, a subdivision of executive government, under a subordinate officer. In the U. States there are the departments of state, justice, interior, war, navy, treasury, post-office, and agriculture. The government is conducted in three separate departments—the legislative, judicial, and executive. The country is subdivided into military departments, each under an officer appointed by the president. In France there are 87 territorial departments.

De Pauw University, at Greencastle, Putnam county, Indiana, one of the chief institutions of learning maintained by the Methodist church in America, constituted in 1837. It is excellently endowed, mainly by the liberality of the Hon. W. C. de Pauw, has a staff of 35 professors and teachers, and over 600 students.

Dep'hal (*Artocarpus Lakoocha*), an Indian tree of the same genus as the bread-fruit and jack, and cultivated for its fruit. The juice is used for bird-lime.

Depil'atories, applications used to remove the hair from the body, especially the face

and scalp, without injuring the texture of the skin. The celebrated *rusma* depilatory consists of quicklime and orpiment (ter-sulphuret of arsenic) boiled in water impregnated with a strong alkaline lye. This mixture is rubbed gently on the parts, which are afterwards washed in warm water.

Depo'nent, (1) in grammar, a verb passive in form but active or neuter in signification. (2) In law, a person who makes an affidavit, or one who gives his testimony in a court of justice; a witness upon oath.

Depos'it, in law, something given or entrusted to another as security for the performance of a contract, as a sum of money or a deed. In commerce, a deposit is generally either money received by banking or commercial companies with a view to employ it in their business, or documents, bonds, &c., lodged in security for loans. In the first case interest is usually paid to the depositor. The receipt given by the banker for money deposited with him is called a *deposit receipt*.

Deposit, in geology, a layer of matter formed by the settling down of mud, gravel, stones, detritus, organic remains, &c., which had been held in suspension in water.

Deposition, in law, the testimony given in court by a witness upon oath. It is also used to signify the attested written testimony of a witness by way of answer to interrogatories. Depositions are frequently taken conditionally, or *de bene esse*, as it is called; for instance, when the parties are sick, aged, or going abroad, depositions are taken, to be read in court in case of their death or departure before the trial comes on.

Deposition of a Clergyman, the degradation of a clergyman from office, divesting him (in churches which do not, like the Church of Rome, hold the indelible nature of orders) of all clerical character. See *Deprivation*.

Dépôt (dā'pō or dep'ō), a French word in general use as a term for a place where goods are received and stored; hence, in military matters, a magazine where arms, ammunition, &c., are kept. The term is now usually applied to those companies of a regiment which remain at home when the rest are away on foreign service. In America it is the common term for a railway-station.

Deprivation, the removing of a clergyman from his benefice on account of heresy, misconduct, &c. It entails, of course, loss of all emoluments, but not the loss of clerical character.

De Profundis, in the liturgy of the Roman Catholic Church, one of the seven penitential psalms, the 130th of the Psalms of David, which in the Vulgate begins with these words, signifying, 'Out of the depths.' It is sung when the bodies of the dead are committed to the grave.

Dept'ford (det'ford), a parliamentary borough, England, in the counties of Kent and Surrey, on the right bank of the Thames, forming now part of London. It has some manufactures of pottery, chemicals, soap, &c. The old naval dockyard was shut up in 1869, but the royal victualling yard is still the largest establishment of its kind. Deptford sends one member to parliament. Pop. 1891, 101,326.

Dep'uty, one who exercises an office as representing another.—*Chamber of Deputies*, the lower of the two legislative chambers in France and in Italy, elected by popular suffrage, and corresponding in some respects to the House of Commons in Britain. See *France, Italy*.

De Quincey, THOMAS, a well-known English author, was the son of a Manchester merchant, and born at Greenhay, near Manchester, on 15th August, 1785. In 1793 his father died, leaving the family a fortune of £30,000. After attending some time the Bath and Manchester grammar-schools, where he showed precocious ability, especially in classical studies, he importuned his guardian to send him to Oxford University, and on being refused he ran away from school, ultimately arriving in London in an absolutely destitute condition. His sufferings at this time he has described in his *Confessions of an English Opium Eater*. At length, in 1803, he matriculated at Oxford, and it was in the second year of his course here that he began to take opium in order to alleviate severe neuralgic pains. On leaving college he settled at Grasnere, Westmoreland, in the vicinity of Wordsworth and Southey, and devoted himself to literary work. Here or in London he remained till 1828, reading voraciously, and writing for the *London Magazine*, *Knight's Quarterly Magazine*, and latterly *Blackwood's Magazine*. From 1828 to 1840 he lived in Edinburgh, then removed with his family to Lasswade, which continued to be his headquarters. He died at Edinburgh December 8, 1859. His writings, nearly all contributions to magazines, are distinguished by power of expression, subtle thought, and an encyclopædic abundance of curious information. He was eccen-

tric in his habits, incapable of managing money matters, but amiable and polite.

Dera Ghazi Khan, a district and town in the Punjab, Hindustan. The former, which is in Derajat division, has an area of 4517 sq. miles and a population of 363,346. The town has a population of 22,309, half Hindus and half Mohammedans. It has extensive manufactures of silk, cotton, and coarse cutlery.

Dera Ismail Khan, a district and a town in Hindustan, in the Punjab, in the division of Derajat. The district lies north of that of Dera Ghazi Khan on both sides of the Indus, and has an area of 9296 square miles, and a population of 441,649. — The town is a staple place for cotton goods. Pop. 22,164.

Derajat (-jät'), a division or commissionership of Hindustan, in the Punjab, occupying part of the valley of the Indus, and comprising Dera Ghazi Khan, Dera Ismail Khan, and Bannu; area 17,681 sq. miles. It is well watered and fertile, and contains numerous towns and villages. Pop. 1,137,572, mostly Mohammedans.

Derbend', or DERBENT', a fortified Russian town, capital of the government of Daghestan, on the west shore of the Caspian, an ancient place formerly belonging to Persia. The manufactures consist of woollen stuffs, copper and iron ware, rose-water, &c.; and there is some trade in saffron, largely grown in the vicinity. Pop. 15,582.

Derby, a municipal and parliamentary borough in England, capital of Derbyshire, on the Derwent, here crossed by an elegant bridge of three arches, 115 miles N.N.W. London. It is pleasantly situated in a wide and fertile valley open to the south, and is well and regularly built in the modern quarter. It has some fine public buildings, amongst which are the churches of All Saints, St. Alkmund, and St. Werburgh, the county hall, school of art, infirmary, &c. There is also a very handsome free library and museum. The principal manufactures are silk, cotton, paper, articles in Derbyshire spar, castings, and porcelain, &c. Derby is one of the oldest towns in the kingdom, and is supposed to owe its origin to a Roman station, *Derventio*, situated at Little Chester, on the opposite side of the river. Under the Danes it took the name of *Deoraby*. Richardson, the novelist, was a native of the town. Derby returns two members to parliament. Pop. 94,146.—The county of Derby, or Derbyshire, in the centre

of the kingdom, is about 55 miles long and from 15 to 30 broad; area, 658,624 acres, or 1029 square miles, five-sixths being arable or in permanent pasture. It exhibits much varied and romantic scenery, the southern and eastern parts having a fertile soil, while the north-western portion is bleak, with a rocky and irregular surface. Here is the loftiest range of the English Midlands, the mountains of the Peak. The Peak itself is 2000 feet high. The principal rivers are the Derwent, the Trent, the Wye, the Erwash, the Dove, and the Rother. Oats and turnips are important crops, and dairy-husbandry is carried on to a large extent. Coal is abundant in various parts of the county, iron ore is also plentiful, and lead, gypsum, zinc, fluor-spar, and other minerals are obtained. The manufactures are silk, cotton and lace, machinery and agricultural implements. The county returns seven members to Parliament. Pop. 1891, 527,886.

Derby, New Haven co., Conn.; has several factories. Pop. in 1890, 5975.

Derby, EDWARD GEOFFREY SMITH STANLEY, FOURTEENTH EARL OF, an English statesman, born at Knowsley Park, Lancashire, March 29, 1799; died there Oct. 23,



Edward, 14th Earl of Derby.

1869. In 1820 he was returned to the House of Commons as member for Stockbridge. At first inclining to the Whig party he joined Canning's ministry in 1827, and in 1830 became chief secretary for Ireland in Lord Grey's government, greatly distinguishing himself by his speeches in favour of the Reform Bill in 1831-32. The

opposition led by O'Connell in the House of Commons was powerful and violent, but Stanley, while supporting a bill for the reform of the Irish Church and the reduction of ecclesiastical taxation, was successful in totally defeating the agitation for the repeal of the Union. He warmly advocated the abolition of slavery, and passed the act for this purpose in 1833; but in the following year a difference of opinion with his party as to the diversion of the surplus revenue of the Irish Church led him to join the Tories. In 1841 he became colonial secretary under Sir Robert Peel, but resigned on Peel's motion for repeal of the corn-laws. In 1851 and 1858 he formed ministries, and again in 1866. Early in 1868 he resigned office. Earl Derby joined to great ability as a statesman, and brilliant oratorical powers, a high degree of scholarly culture and literary ability.—EDWARD HENRY STANLEY, fifteenth earl of Derby, was born in 1826; educated at Rugby, and Trinity College, Cambridge. In 1852 he was under secretary of foreign affairs; afterward secretary of state for India. Under his superintendence the management of the British India empire was transferred from the East India company to the government of Great Britain. In 1866 and also in 1874 he was secretary of state for foreign affairs. Lord Derby became a Liberal in 1879, and was secretary of state for the colonies under Mr. Gladstone from 1882 to 1885. He, however, took a stand against Irish Home Rule in 1886, and had since ranked among Mr. Gladstone's opponents. He died April 21, 1893.

Derby-day, the great annual London holiday, on which the horse-race for the stakes instituted by Lord Derby in 1780 is run. It always falls on a Wednesday. The race is run on Epsom Downs, an extensive plain in the neighborhood of London. The entry-money for each subscriber is fifty guineas, and the stakes are run for by colts of three years. The entries are so numerous that the value of the stakes reaches several thousand pounds. On Epsom Downs, on the Derby-day, are assembled all classes, high and low.

Derbyshire. See *Derby*.

Derbyshire Neck. See *Goitre*.

Derbyshire Spar. See *Fluor-spar*.

Derecske (de-rech'ke), a town of Hungary, in the county of Bihar. Pop. 7630.

Dereham (dēr'am), EAST, a town in England, nearly in the centre of the county of

Norfolk, with manufactures of agricultural implements, iron-foundries, and a brisk trade. The poet Cowper was buried in the church here. Pop. 5640.

Der'elict, a vessel or anything relinquished or abandoned at sea, but most commonly applied to a ship abandoned by the crew and left floating about.

Derg, LOUGH: (1) a lake, Ireland, county of Donegal, about 3 miles long by $2\frac{1}{2}$ broad at the broadest part, and studded with islets, one of which, called Station Island, was formerly a great resort of Roman Catholic pilgrims; (2) an expansion of the river Shannon between co. Tipperary and cos. Clare and Galway, about 24 miles long and averaging 2 miles in breadth.

Derham, WILLIAM, English philosopher and divine, born in 1657, died 1735. He was long rector of Upminster in Essex. His best-known works are entitled *Physico-Theology*, *Astro-Theology*, and *Christo-Theology*.

Derivation. See *Etymology*.

Derma, DERMIS, the true skin, or under layer of the skin, as distinguished from the cuticle, epidermis, or scarf-skin.

Dermatology, the branch of medicine which treats of the skin and its diseases.

Dermat'ophyte, a parasitic plant, chiefly of the lowest type of the Cryptogamia, infesting the cuticle and epidermis of men and other animals, and giving rise to various forms of skin-disease, as ringworm, &c.

Dermes'tes, a genus of coleopterous insects, one species of which (*D. lardarius*) is known by the name of bacon-beetle, and is often found in ill-kept ham or pork shops.

Dermot Mac Murragh, the last Irish King of Leinster, attained the throne in 1140. Having carried off the wife of O'Ruarc, prince of Leitrim, he was attacked by the latter, and after a contest of some years driven out of Ireland (1167). He then did homage to the English king, and with the help of Richard, earl of Pembroke, recovered his kingdom, but died in the same year (1170), and was succeeded by Pembroke, who had married his daughter.

Derna, a town in Barca, on the north coast of Africa. Pop. 6000.

Der'rick, a lifting apparatus consisting of a single post or pole, supported by stays and guys, to which a boom with a pulley or pulleys is attached, used in loading and unloading vessels, &c. Floating derricks of the strongest construction, with an immense boom and numerous blocks, are also used.

Derrick-crane, a kind of crane combining the advantages of the common derrick and those of the ordinary crane. The jib of this crane is fitted with a joint at the foot, and has a chain instead of a tension-bar attached to it at the top, so that the inclination, and consequently the sweep, of the crane can be altered at pleasure.

Derry. See *Londonderry*.

Der'vish, or DERVISE (Persian, poor), a Mohammedan devotee, distinguished by austerity of life and the observance of strict forms. There are many different orders of them.

Some live in monasteries, others lead an itinerant life, others devote themselves to menial or arduous occupations. They are respected by the common people, and the mendicants among them carry a wooden bowl into which the pious cast alms. One of their forms of devotion is dancing or



Travelling Dervish of Khorasan.

whirling about, another is shouting or howling, uttering the name *Allah*, accompanied by violent motions of the body, till they work themselves into a frenzy and sometimes fall down foaming at the mouth. They are credited with miraculous powers, and are consulted for the interpretation of dreams and the cure of diseases.

Der'went, the name of four rivers in England, in Derbyshire, Yorkshire, Durham, and Cumberland respectively, the last draining Derwentwater Lake. Also a river in Tasmania.

Der'wentwater, or KESWICK LAKE, a beautiful lake in Cumberland, England, in the vale of Keswick. It is about 3 miles in length and $1\frac{1}{2}$ in breadth, and stretches from Skiddaw on the north to the hills of Borrowdale. Near the north-east corner is the celebrated cascade of Lodore. Its waters are carried to the sea by the Derwent.

Derwentwater, JAMES RATCLIFFE, LAST EARL OF, one of the leaders in the rebellion

of 1715, born in London June 28, 1689. The standard of revolt having been raised in Scotland, Lord Derwentwater commenced the movement in England on 6th October, 1715, but was forced, along with the other Jacobite nobles, to surrender at discretion on 13th of November. He was executed on Tower Hill 24th Feb. 1716, his estates being confiscated, and in 1735 granted to Greenwich Hospital.

Derzhawin (der-zhă'vin), GABRIEL ROMANOWITCH, a Russian lyric poet, born in 1743. He entered the army as a private soldier, distinguished himself highly, and was eventually transferred to the civil service, in which he obtained the highest offices. In 1803 he retired from public life and devoted himself entirely to poetry. One of his most beautiful poems is the Oda Bog, or Address to the Deity. He died in 1816.

Desaguadero (des-â-gwâ-dă'rō), a river of Bolivia, in a valley of the same name, issuing from Lake Titicaca, and carrying its waters into Lake Aullagas. Also a river in the Argentine Confederation flowing into Lake Bevedero Grande, and separating the provinces of San Juan and Mendoza. Desaguadero signifies in Spanish 'a channel of outlet.'

Desaix de Veygoux (dê-sî dé vâ-gö), LOUIS CHARLES ANTOINE, a distinguished French general, born in 1768 at St. Hilaire d'Ayat, in Auvergne. He was of noble family, and entered the army as a sub-lieutenant. He distinguished himself greatly in 1794 under Pichegru, and two years later with the army of the Rhine under Moreau. In 1797 he accompanied Bonaparte to Egypt, and was very successful in reducing Upper Egypt. After the Treaty of El Arish he followed Bonaparte to Italy, took command of the corps of reserve, and, arriving on the field of Marengo at a critical moment, decided the victory by a brilliant charge, June 14, 1800. He himself fell, mortally wounded by a cannon shot.

Desault (dê-sō), PIERRE JOSEPH, one of the most celebrated surgeons of France, was born in 1744, and died in 1795. After some experience in the military hospital at Bèfort he went to Paris in 1764, studied under Petit, and two years afterwards became a lecturer on his own account. His reputation soon increased, and he became principal surgeon in the hospital De la Charité, and in 1788 was put at the head of the great Hôtel Dieu in Paris. Here he founded a surgical school, in which many of the most

eminent surgeons of Europe were educated.

Des'cant, in music, an addition of a part or parts to a subject or melody, a branch of musical composition which preceded the more modern counterpoint and harmony, coming into existence at the end of the 11th or beginning of the 12th century.

Descartes (dâ-kärt), RENÉ, a great French philosopher and mathematician, with whom the modern or new philosophy is often considered as commencing, was born March 31, 1596, at La Haye, in Touraine. He was educated at the Jesuit College of La Flèche, where he showed great talent. He entered the military profession and served in Holland and in Bavaria. In 1621 he left the army, and after a variety of travels finally settled in Holland, and devoted himself to philosophical inquiries. Descartes, seeing the errors and inconsistencies in which other philosophers had involved themselves, determined to build up a system anew for himself, divesting himself first of all the beliefs he had acquired by education or otherwise, and resolving to accept as true only what could stand the test of reason. Proceeding in this way he found (*Meditationes de Prima Philosophia*) that there was one thing that he could not doubt or divest himself of the belief of, and that was the existence of himself as a thinking being, and this ultimate certainty he expressed in the celebrated phrase '*Cogito, ergo sum*' (I think, therefore I am). Here, then, he believed he had found the test of truth. Starting from this point Descartes found the same kind of certainty in such propositions as these: that the thinking being or soul differs from the body (whose existence consists in space and extension) by its simplicity and immateriality and by the freedom that pertains to it; that every perception of the soul is not distinct; that it is so far an imperfect finite being; that this imperfection of its own leads it to the idea of an absolutely perfect being; and from this last idea he deduces all further knowledge of the truth. Descartes also contributed greatly to the advancement of mathematics and physics. The higher departments of geometry were greatly extended by him. His system of the universe attracted great attention in his time, though long since exploded. It rested on the hypothesis of celestial *vortices*, immense currents of ethereal matter, by which he accounted for the motion of the planets (*Principia Philosophiæ*, 1644). His works effected a

great revolution in the principles and methods of philosophizing. In 1647 the French court granted him a pension of 3000 livres, and two years later, on the invitation of Christina of Sweden, he went to Stockholm, where he died Feb. 11, 1650.

Descendants. See *Descent*.

Descent', in law, is the transmission of the right and title to lands to the heir, on the decease of the proprietor, by the mere operation of law. The rule determining to whom an estate belongs, on the decease of the proprietor, is that of consanguinity, or relationship by blood, though with some exceptions, as in the case of the portion, or the use of a portion, of a man's property given by the laws of Britain to his widow. The rules of descent, designating what relations shall inherit, and their respective shares, will be determined by the genius and policy of the government and institutions. Hence the practice of entailments in the feudal system. And wherever the government is founded in family privileges, or very intimately connected with them, as is the case in all governments where the hereditarily aristocratic part of the community have a great preponderance, the sustaining of families will very probably be a characteristic feature in the code of laws. Thus, in Britain, all the lands of the father, unless otherwise directed by will, go to the eldest son. In the U. States of America this distinction in favour of the eldest son has been abolished, and the laws there are founded upon the principle of equal distribution both of real and personal estate among heirs of the nearest surviving degree. Kindred in blood are divided into three general classes, viz. 1, descendants; 2, ancestors; 3, collateral relatives, that is, those who have descended from the same common ancestor. The civil law computes the degrees by counting the generations up to the common ancestor, as father, grandfather, great-grandfather; or mother, grandmother, great-grandmother; and from him or her down to the collateral relative, as brother, cousin, &c., making the degree of relationship the sum of these two series of generations. Every person has two sets of ancestors, the paternal and maternal, and therefore two sets of collateral relatives. There is also a distinction of collateral kindred, into those of the whole blood and those of the half blood.

Deseada (de-se-ä'dä), or **DÉSIRADE**, one of the Leeward Islands, belonging to the French, in the Caribbean Sea, about 10 miles

long and hardly 5 broad. The soil is in some places black and good, in others sandy and unproductive. Pop. 1788.

Des'eret. See *Utah*.

Des'ert, a term more particularly applied to vast barren plains such as are found in Asia and Africa, but which may also be used to designate any solitude or uninhabited place whether barren or not. See *Sahara* and *Gobi*.

Deser'ter, a soldier or sailor who quits the service without leave. Deserters are tried by court-martial, which may inflict death as the extreme punishment, or a less severe punishment, according to the circumstances of the case.

Desertion, by husband or wife, without due cause, is in England ground for a judicial separation. A wife may obtain an order to protect any money or property she may have acquired since desertion, against her husband or his creditors. Desertion in most of the States of the Union constitutes a ground of divorce, though they differ as to the period of time which must elapse before action can be brought.

Desful. See *Dizful*.

Deshoulières (dā-söl-yār), ANTOINETTE DU LIGIER DE LAGARDE, a French lady of much literary reputation in the 17th century; born 1634, died 1694. She was the centre of attraction in the best circles of the period, and was elected a member of several learned societies. Among her works are odes, eclogues, idyls, and a tragedy, *Genseric*.

Desiccation, a process of dispelling moisture by the use of air, heat, or chemical agents such as chloride of calcium, quicklime, oil of vitriol, and fused carbonate of potash.—*Desiccation cracks*, in geology, are the fissures caused in clayey beds by the sun's heat, and seen in various rock strata.

Design, thought, arrangement, or grouping, imagination or invention in works of art. A design is a composition or invention, pictorial, architectural, or decorative. It may be simply an imperfect sketch, as a record of a first thought; or it may be a fully matured work, as a cartoon in preparation for fresco painting, or a drawing to illustrate a book.

Désirade (dā-zē-räd). See *Deseada*.

Des'man. See *Musk-rat*.

Desmidia'ceæ, DESMIDIE'Æ, a nat. order of microscopic, fresh-water, confervoid Algæ. They are green gelatinous plants composed of variously formed cells having a bilateral

symmetry, which are either free, or in linear series, or collected into bundles or into star-like groups, and imbedded in a common gelatinous coat. Desmidiaceæ differ from Diatomaceæ in their green colour and absence of silex.

Desmo'dium, a genus of plants. See *Moving Plant*.

Des Moines (dè moin), a city of the U. States, capital of the state of Iowa and of Polk county, on the Des Moines river, about 350 miles west of Chicago. Among its chief buildings are the new state house, the state arsenal, colleges, opera-houses, &c. There are coal-mines in the vicinity, and the manufactures and other industries are varied and rapidly increasing. Pop. 50,093.

Des Moines, the largest river in the state of Iowa, rises in the s.w. of Minnesota and flows in a south-easterly direction till it falls into the Mississippi about 4 miles below Keokuk, after a course of 300 miles.

Desmol'ogy (Greek, *desmos*, a ligament), that branch of anatomy which treats of the ligaments and sinews.

Desmoulins (dā-mö-lan), BENOÎT CAMILLE, born in 1760 or 1762, was conspicuous during the first period of the French revolution. He was amongst the most notable of the pamphleteers and orators who urged the multitude forward in the path of revolution. He, along with others, prepared the plan for the taking of the Bastille (July, 1789), was one of the founders of the club of Cordeliers, and the promoter of the assembly in the Champ de Mars. In 1793 he gave his vote for the death of the king. Having become closely connected with Danton and the party of opposition to Robespierre, and inveighing against the reign of blood and terror, he was arrested on the order of the latter on 30th March, 1794, tried on the 2d of April, and executed on the 5th. He met his fate in an agony of despair.

Desna, a river in Russia, which rises in the government of, and about 50 miles east of the town of Smolensk, flows through the governments of Orel and Tchernigov till it joins the Dnieper near Kiev. It is 500 miles in length and navigable nearly throughout.

De Soto, HERNANDO, a Spanish explorer and discoverer of the Mississippi, born about 1496, died in 1542. He accompanied expeditions to the New World under Davila and Pizarro, and played a distinguished part in the conquest of Peru. In 1539 he led an expedition to Florida, whence after many

difficulties he penetrated to the Mississippi, where he was attacked with fever and died. —The name De Soto has been given to a county in the n.w. of Mississippi, and to several places in the U.S.

Des'pot (Greek, *despotēs*), originally a master, a lord; at a later period it became an honorary title which the Greek emperors gave to their sons and sons-in-law when governors of provinces. At present *despot* means an absolute ruler, as the Emperor of Russia, and in a narrower sense a tyrannous one.

Dessalines (dā-sā-lēn), JEAN JACQUES, Emperor of Hayti, born in Africa about 1760, was a slave in 1791, when the insurrection of the blacks occurred in that island, but was set free along with the other slaves in St. Domingo in 1794. His talents for war, his courage, and unscrupulous conduct raised him to command in the insurrections of the coloured people, and after the deportation of Toussaint-L'Ouverture, and the subsequent evacuation of the island by the French, Dessalines was appointed governor-general for life with absolute power; and the year following (1804) was declared emperor with the title of Jacques I. But his rule was savage and oppressive, and both the troops and the people, sick of his atrocities, entered into a conspiracy against him, and, Oct. 17, 1806, he was slain by one of his soldiers.

Dessau (des'ou), a town in Germany, capital of the duchy of Anhalt, in a beautiful valley on the left bank of the Mulde, mostly well built, with fine squares and many handsome buildings. The manufactures consist of woollens, woollen yarn, carpets, machinery, tobacco, &c. The ducal palace has a picture-gallery and interesting relics and antiquities. Pop. 1890, 34,658.

De Stendhal. See *Beyle, Marie-Henri*.

Dester'ro, a seaport of Brazil, capital of the province of Santa-Catharina. The harbour is, next to that of Rio de Janeiro, the best on the Brazilian coast. Pop. 9000.

Destutt de Tracy, ANTOINE LOUIS CLAUDE, French philosophical writer, born in 1754 of a family of Scottish extraction; died in 1836. As a philosopher he belonged to the Sensationalist school, and considered all our knowledge to be derived originally from sensation. Among his chief works are *Idéologie* (1801), *Logique* (1805), *Traité de la Volonté* (1815).

Detach'ment, a body of troops selected from the main army for some special service.

Deter'minism, a philosophical theory which holds that the will is not free, but is invincibly determined either—according to the older form of the theory—by a motive furnished by Providence, or—according to the modern form—by the aggregation of inherited qualities and tendencies.

Det'inue, in law, the form of action whereby a plaintiff seeks to recover a chattel personal unlawfully detained.

Det'mold, a town, Germany, capital of Lippe-Detmold, on the left bank of the Werra, 50 miles south-west of Hanover, with a new and an old palace (or castle), good public library, museum, &c. In the vicinity a colossal statue has been erected to the Hermann or Arminius who overthrew the Roman general Varus and his legions in a battle which was fought near this place. Pop. 8913.

Det'onating Powders, certain chemical compounds, which, on being exposed to heat or suddenly struck, explode with a loud report, owing to one or more of the constituent parts suddenly assuming the gaseous state. The chloride and iodide of nitrogen are very powerful detonating substances. The compounds of ammonia with silver and gold, fulminate of silver and of mercury, detonate by slight friction, by means of heat, electricity, or sulphuric acid.

Detonating Tube, a species of eudiometer, being a stout glass tube used in chemical analysis for detonating gaseous bodies. It is generally graduated into centesimal parts, and perforated by two opposed wires for the purpose of passing an electric spark through the gases which are introduced into it, and which are confined within it over mercury and water.

Detri'tus, in geology, small fragments of matter worn off or detached from solid bodies by attrition, distinguished from debris, which is made up of larger fragments.

Detroit (de-troit'; Fr. *détroit*, a strait or channel), a flourishing port and city of the United States, the largest town in Michigan, situated on the Detroit River, connecting Lakes Erie and St. Clair. The site rises gradually from the river, and the city is generally well built. Among the chief edifices are the city hall, the house of correction, post-office, opera-house. Latterly Detroit has increased very rapidly, a fact which is due to its admirable position for trade, and to its connections with a region into which a constant tide of emigration is flowing. Among the industrial establish-

ments are saw-mills, flour-mills, building-yards for ships and boats, foundries, tanneries, blast-furnaces, pork-packing establishments, tobacco and cigar manufactories, breweries, locomotive works, &c. The harbour is one of the finest in the United States, and has a depth of water sufficient for the largest vessels. Detroit owes its origin to the French, who formed a settlement here in 1701. Pop. 205,876.

Detroit River, or STRAIT OF ST. CLAIR, a river or strait of North America, which runs from Lake St. Clair to Lake Erie. It is 28 miles long, and of sufficient depth for the navigation of large vessels. It is about $\frac{3}{4}$ mile wide opposite Detroit and enlarges as it descends.

Dettingen (det'ing-en), the name of several places in Germany, amongst which is a village of Bavaria, on the right bank of the Main, famous for the victory gained by the English and Austrians under George II. of England over the French in 1743.

Deuca'lon, in Greek mythology, the son of Prometheus and father of Hellen, ancestor of the Hellenes. According to tradition he saved himself and his wife, Pyrrha, from a deluge which Zeus had sent upon the earth by building a ship which rested upon Mount Parnassus. To repair the loss of mankind they were directed by an oracle to throw stones behind them, which became men and women.

Deus ex Machinâ (mak'i-na; L. 'a god out of the machine'), a phrase used to designate the resorting to supernatural causes to explain phenomena that one is not able to account for by natural means. The phrase is taken from the practice on the classical stage of introducing a god from above by means of some mechanical contrivance in order to effect a speedy denouement of the plot.

Deutero-canonical, a term applied to those books of Scripture that were admitted into the canon after the rest, some of them being regarded by Protestants as apocryphal.

Deuteron'omy, the last of the books of the Pentateuch, so called (Greek, *deuteros*, second, *nomos*, a law) from its consisting in part of a restatement of the law as already given in Exodus, Leviticus, and Numbers, and containing also, in addition to special commands and admonitions not previously given, an account of the death of Moses. See *Pentateuch*.

Deutz (doits), a town in Prussia, on the right bank of the river Rhine, opposite the

city of Cologne, with which it communicates by a bridge. It is strongly fortified as part of the defences of Cologne—forming, in fact, a *tête-du-pont*. There are some manufactories of porcelain and glass, also an iron-foundry, machine-works, and a large establishment for the construction of artillery. Pop. 17,737.

Deut'zia, a genus of plants, natural order Philadelphaceæ, containing seven or eight species, all of which are interesting from the beauty of their flowers, some of them favourite garden and greenhouse plants. They are small shrubs indigenous to China and Japan, and Northern India.

Deux-Ponts (deu-pōn), the French name for the German town *Zweibrücken* (which see), both names meaning 'two bridges.'

Devanagari (dā-va-nā'ga-rē), a name of the Sanskrit alphabet.

Development Theory. See *Evolution*.

Dev'enter, an old town in Holland, prov. of Overijssel, 8 miles north from Zutphen, at the confluence of the Schipbeek and Ijssel. Its industries embrace carpets, cast-iron goods, printed cottons, hosiery, and a kind of cake called Deventer cakes. It has a large export trade in butter. Pop. 22,700.

Devereux, ROBERT. See *Essex*, *Robert Devereux*, *Earl of*.

Dev'eron, a river of Scotland belonging to Aberdeenshire and Banffshire, 60 miles long.

Deviation of the Compass, the deviation of a ship's compass from the true magnetic meridian, caused by the near presence of iron. In iron ships the amount of deviation depends upon the direction, with regard to the magnetic meridian, in which the ship lay when being built. It is least when the ship has been built with her head south. Armour-plated ships should be plated with their head in a different direction from that in which they lay when built. The mode now generally employed to correct deviation is by introducing on board ship masses of iron and magnets to exactly neutralize the action of the ship's magnetism. Compasses are sometimes carried on masts in iron vessels as a means of removing them from the disturbing influence of the iron of the hull. In this position they serve as standards of comparison for the binnacle compass. Wooden ships are also affected, though in a far less degree, by the direction in which they lie when building.

Device', a name common to all figures, ciphers, characters, rebuses, mottoes, &c., which are adopted by a person or a family

by way of badge or distinctive emblem, often a representation of some natural body, with a motto or sentence applied in a figurative sense.

Devil (Greek, *diabolos*, a slanderer or accuser), in theology, an evil spirit or being; specifically the evil one, represented in Scripture as the traducer, father of lies, &c. Most of the old religions of the East acknowledge a host of devils. The doctrine of Zoroaster, who adopted an evil principle called Ahriman, opposed to the good principle and served by several orders of inferior spirits, spread the belief in such spirits among the people. The Greek mythology did not distinguish with the same precision between good and bad spirits. With the Mohammedans *Eblis*, or the devil, was an archangel whom God employed to destroy a pre-Adamite race of *jinnis*, or genii, and who was so filled with pride at his victory that he refused to obey God. The Satan of the New Testament is also a rebel against God. He uses his intellect to entangle men in sin and to obtain power over them. But he is not an independent self-existent principle like the evil principle of Zoroaster, but a creature subject to omnipotent control. The doctrine of Scripture on this subject soon became blended with numerous fictions of human imagination, with the various superstitions of different countries, and the mythology of the pagans. The excited imaginations of hermits in their lonely retreats, sunk as they were in ignorance and unable to account for natural appearances, frequently led them to suppose Satan visibly present; and innumerable stories were told of his appearance, and his attributes—the horns, the tail, cloven foot, &c.—distinctly described. In consequence of the cures which Christ and his apostles performed on the possessed, the early church believed in a power connected with the consecration of priests to drive out evil spirits. (See *Exorcism*.) The belief in evil spirits, witches, &c., was in the 17th century so common that they became the objects of judicial process. With the progress of the natural sciences, however, in the 18th century many wonderful phenomena became explained, and less was heard of witchcraft.

Devil, the machine through which cotton or wool is first passed to prepare it for the carding-machines; a teasing-machine.

Devil, TASMANIAN. See *Dasyure*.

Devil-fish, the popular name of various fishes, one of them being the angler (which

see). Among others the name is given to several large species of ray occasionally captured on the Atlantic and Pacific coasts of America, and much dreaded by divers, whom they are said to devour after enveloping them in their vast wings. During gales of wind or from strong currents these immense fish are driven into shoal water, and being unable to extricate themselves, fall an easy prey to the vigilance of the fishermen, who obtain considerable quantities of oil from their livers.

Devil's Advocate. See *Advocatus Diaboli*.

Devil's Bit, the common name of a species of scabious (*Scabiōsa succisa*), nat. order Dipsacæ. It has heads of blue flowers nearly globular, and a fleshy root, which is, as it were, cut or bitten off abruptly. The sweet scabious is a well-known fragrant garden flower.

Devil's Bridge (*Teufelsbrücke*), a famous bridge in Switzerland, over the Reuss, built of stone from mountain to mountain, 75 feet in length, on the road over St. Gothard, from Germany to Italy.

Devil's Dust, a name sometimes applied to old woollen goods when torn up into their original fibres, to be woven again into new fabrics, called *shoddy*.

Devil's Punch-bowl, a small lake of Ireland, near the Lakes of Killarney, between 2000 and 3000 feet above the sea, supposed to be the crater of an ancient volcano.

Devil's Wall, in the south of Germany, a structure which was originally a Roman rampart, intended to protect the Roman settlements on the left bank of the Danube and on the right bank of the Rhine, against the inroads of the Teutonic and other tribes. Remains of it are found from the Danube, in Bavaria, to Bonn on the Rhine.

Devil-worship, the worship paid to the devil, an evil spirit, a malignant deity, or the personified evil principle in nature, by many of the primitive tribes of Asia, Africa, and America, under the assumption that the good deity does not trouble himself about the world; or that the powers of evil are as mighty as the powers of good, and have in consequence to be bribed and reconciled. There is a sect called devil-worshippers inhabiting Turkish and Russian Armenia and the valley of the Tigris, who pay respect to the devil, to Christ, and to Allah or the supreme being, and also worship the sun.

Devise, in law, usually the disposition of real estate by will, but also sometimes ap-

plied to any gift by will, whether of real or personal estate.

Devi'zes, a town in England, county of Wilts (formerly a parliamentary borough), finely situated on a commanding eminence, 82 miles west by south of London. The name is derived from the Latin *divisæ terræ*, divided lands), because the ancient castle of Devizes was built at the meeting-place of three different manors. Agricultural engines and implements are made, and malting is carried on. Pop. 8293.

Devon, DEVONSHIRE, a maritime county in the s.w. of England, its northern coast being on the Bristol Channel and its southern on the English Channel; area, 1,655,208 acres, or 2586 square miles, the county being the third largest of England. Its principal rivers are the Torridge and the Taw, flowing north into the Bristol Channel; and the Exe, Axe, Teign, Dart, and Tamar, flowing into the English Channel. From Exeter to the confines of Cornwall extends the wide and barren tract called Dartmoor; but the vale of Exeter, comprising from 120,000 to 130,000 acres, and the south extremity of the county called *South Hams*, limited by a line drawn from Torbay to Plymouth Sound, are amongst the most fertile districts of England. Tin, lead, iron, copper, manganese, granite, and the clay used by potters and pipe-makers are the chief mineral products. The geological formation of the Old Red Sandstone is so largely developed that the term Devonian has to some extent become its synonym. Agriculture is in a somewhat backward state, owing, probably, to the general preference given to dairy husbandry, for which the extent and richness of its grass lands make the county most suitable. Wheat, barley, beans, pease, and potatoes are the principal crops. About three-fourths of the county are under crops or in pasture. There is a large trade in butter, cheese, and live stock, and the 'clotted' cream and cider of Devonshire are well known as specialties of the county. There are eight parliamentary divisions, each with one member. Pop. 631,767.

Devo'nian System, in geology, a name originally given to rocks of Devonshire and Cornwall, intermediate between the Silurian and Carboniferous strata, and consisting of sandstones of different colours, calcareous slates and limestones, &c. They are divided into lower, middle, and upper groups, all containing fossils, but the middle most abounding in them, including corals, crinoids,

crustaceans, mollusca (especially brachiopods), and cephalopods. Devonian rocks occupy a large area in Central Europe, as well as in the United States, Eastern Canada, and Nova Scotia. The term has been often used as equivalent to Old Red Sandstone.

Dev'onport, a municipal and parliamentary borough and port of England, county of Devon, contiguous to Plymouth. It is the seat of one of the royal dockyards, and an important naval and military station. A bastioned wall and fosse defends the town on the north-east and south sides, while the sea entrance is protected by heavy batteries on Mount Wise. Connected with the dockyards and fortifications are the gun wharf, foundries, machine-works, rope-walks, storehouses, naval and military barracks, &c. It has no special trade beyond that connected with the dockyards and government works. Devonport returns two members to parliament. Pop. 1891, 54,736.

Devonshire. See *Devon*.

Devonshire, DUKE OF. See *Cavendish*.

Dew is a deposition of water from the atmosphere upon the surface of the earth in the form of minute globules. The earth absorbs heat during the day, at sunset its supply is cut off but the radiation continues. Grass and foliage being radiators lose their heat and the moisture of the atmosphere is condensed by contact therewith. See *Dew-point*.

Dewas, Central India. Pop. 142,162.

Dewey Day: New York City, May 4, designated by the Legislature as Charter Day, a legal holiday, was by resolution of the Board of Aldermen changed from the latter to the former title. Chicago, Cincinnati, Kansas City and St. Louis have appointed May 1 as Dewey Day in commemoration of his victory at Manila.

Dewey, GEORGE, Rear-Admiral, born 1837, youngest son of Dr. Julius Y. Dewey, who was president of the National Life Ins. Co. of Vermont, who married Susan, daughter of Governor Goodwin, Portsmouth, N. H. He was appointed to the Naval Academy Sep. '54. Graduated '58 and joined the frigate *Wabash* for a Mediterranean cruise. Eight days after Fort Sumter was fired on (Apr. 19, '61) was commissioned as Lieutenant and assigned to the *Mississippi*, which, under Farragut, took part in forcing the Miss. river. Mar. '63 she ran ashore in centre line of fortifications and was riddled from stem to stern. Dewey fired her and escaped with the crew

to the opposite shore. On the steam-gun-boat *Agawan* he joined in the attacks on Fort Fisher, Dec. '64, Jan. '65. May '65 commissioned Lieut.-Commander, serving on the famous *Kearsage*, Colorado and European squadron till '68. His first command was a survey of the Pacific '70-76 on the *Narragan*. Appointed L. H. Inspector in latter year and shortly after Secretary of the Board. Commanded *Juniata*, Asiatic station, 1882-83; Sep. '84 made Captain and given charge of *Dolphin*, forming one of the first ships of the 'White Squadron.' In 1885 sent to command flagship *Pensacola*, European squadron, until '88, when appointed Chief of Bureau of Equipment and Recruiting with rank of Commodore. In '93 became member of Lighthouse Board and received commission as Commodore Feb. 28, '96; he held this until placed in command of Asiatic squadron, Jan. '98. May 1, '98, fought the Battle of Manila, silencing the forts and destroying the Spanish fleet, without the loss to himself of a man or ship. May 11, '98, Congress unanimously adopted a resolution of thanks, granted him a sword of honor and placed him on the active list as Rear-Admiral for life. Aug. 13, '98, he, in conjunction with Genl. Merritt, attacked Manila, reduced it and took possession.

Dewberry (*Rubus cæsius*), an edible fruit belonging to the order of the Rosaceæ, and to the same genus as the bramble, from which it is distinguished by its smaller berries, with fewer grains, and by the bloom, resembling dew, with which they are covered, and from which the plant derives its name. It is common in some parts of England. It abounds from Canada to Virginia.

De Wint, PETER, English landscape-painter in water-colours; born 1784, died 1849. He studied in the schools of the Royal Academy, where he occasionally exhibited; but most of his pictures were shown in the exhibitions of the Water-colour Society. English scenery was his favourite subject. He occasionally painted in oil with marked success.

De Witt, JAN, Grand-pensionary of Holland, celebrated as a statesman and for his tragical end, was the son of Jacob de Witt, burgomaster of Dort, and was born in 1625 or 1632. He became the leader of the political party opposed to the Prince of Orange, and in 1652, two years after the death of William II., was made grand-pensionary. In 1665 the war with England was renewed and conducted by De Witt with great

ability till its termination in 1665. In 1672 Louis XIV. invaded the Spanish Netherlands and involved Holland in war. De Witt's popularity, already on the decline, suffered still further in the troubles thus occasioned, and he felt it necessary to resign his office of grand-pensionary. At this time his brother Cornelius, who had been tried and put to torture for conspiring against the life of the young Prince of Orange, lay in prison. Jan de Witt went to visit him, when a tumult suddenly arose amongst the people, and both brothers were murdered, Aug. 20, 1672. De Witt was a man of high character, simple and modest in all his relations.

Dew-point, the temperature at which condensation of the vapour in the air takes place. When the temperature of the air has been reduced by radiation to the dew-point, dew is deposited and an amount of heat set free which raises the temperature of the air. Thus the dew-point will indicate what the minimum temperature of the night is likely to be, a knowledge of which is useful to the horticulturist.

Dewsbury, a town, England, in the West Riding of Yorkshire, and 30 miles southwest of the town of York, chiefly engaged in the manufacture of heavy woollen cloths, including blankets, carpets, rugs, flannels, baizes, &c. In 1862 it was made a municipal borough, in 1867 a parliamentary borough, returning one member. Pop. of municipal bor. 29,847; of parl. bor. 1891, 72,983.

Dexter, a term meaning on the right-hand side, chiefly used in heraldry. The *dexter chief point* is a point in the right-hand upper corner of the shield, being in the dexter extremity of the chief.

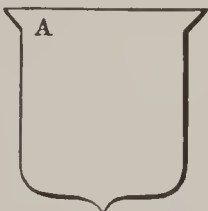

A, Dexter chief point.

Dex'trine ($C_6H_{10}O_5$), the soluble or gummy matter into which starch can be converted by the action of dilute acids or malt extract, or by heat. It is remarkable for the extent to which it turns the plane of polarization to the right hand, whence its name. Its composition is the same as that of starch. By the action of hot diluted acids dextrine is finally converted into grape-sugar. It is white, insipid, and without smell. It is a good substitute for gum-arabic in medicine.

Dextro-compounds, bodies which cause the plane of a ray of polarized light to ro-

tate to the right. Dextrine itself, dextro-glucose, tartaric acid, malic acid, cinchonine, and many other bodies have this property; while others, which have the opposite effect, of causing the plane to rotate to the left, are called *levo-compounds*.

Dex'trose, a name for grape-sugar (which see).

Dey, a title formerly assumed by the rulers (under the Turkish Sultan) of Algiers, Tripoli, and Tunis.

Dezful. See *Dizful*.

Dhalak (dhâ-lâk'), an archipelago of the Red Sea, off the coast of Abyssinia. It consists of nearly 100 rocks and islets, mostly uninhabited, clustering round the island of Dhalak el-Kebir, which is about 35 miles long by 30 broad. This island possesses a pearl-fishery.

Dhar (dhâr), a small native state in Central India, with an area of about 1740 sq. miles. The soil is fertile, and yields wheat, rice, opium, &c. Pop. 149,244. The capital is of the same name, is surrounded by a mud wall, and has some striking buildings. Pop. 15,224.

Dhârangâon, a town of Hindustan, in Khandesh district, Bombay. Pop. 13,081.

Dhârapuram, a town of Hindustan, Coimbatore district, Madras. Pop. 7310.

Dharmkot, a town of India, in Ferozpur district, Punjab. Pop. 6007.

Dharmśâla, a hill station with military cantonments, in Kangra district, Punjab, India. Pop. 5322.

Dhârwar, the chief town of Dharwar district, in the Bombay Presidency, Hindustan, a straggling place with some trade. There is a fort well planned and strongly situated, but now falling into ruins, and military cantonments at 2 miles' distance. Pop. 27,191. The Dharwar district has an area of 4535 sq. miles; pop. 882,907.

Dhawala'giri, or **DHAULÁGIRI**, one of the highest peaks of the Himalayas, in Nepál; height, 26,826 ft.

Dhole (dōl), the Cingalese name for the wild dog of India (*Cyon dukhuensis*). It is distinguished from the genus *Canis* or dog proper by its having one molar fewer in either side of the lower jaw. It is of a fox-red or rufous-fawn colour, in size between a wolf and a jackal, and hunts always in packs.

Dholera (dhō-lā'-ra), a seaport of Hindustan, Bombay Presidency, one of the chief cotton-marts in the Gulf of Cambay. Pop. 10,301.

Dholka, a town of Hindustan, Bombay Presidency, probably one of the oldest towns in Gujarat. Pop. 17,716.

Dholpur, native state of Central India, Rajputána; area, 1200 square miles; pop. 249,657. The capital is also called Dholpur. Pop. 15,833.

Dhow (dou), an Arab sea-going vessel, ranging from a comparatively small size up to 250 tons burden, with one mast and a



Slave Dhow, east coast of Africa.

large square sail. It is used for merchandise and is often employed in carrying slaves from the east coast of Africa to Arabia.

Dhúliá, a town of Hindustan, Khandesh district, Bombay Presidency. Pop. 18,449.

Dhurra, **DOURAH** (dū'ra), Indian millet, the seed of *Sorghum vulgāre*, after wheat the chief cereal crop of the Mediterranean region, and largely used in those countries by the labouring classes for food. Varieties are grown in many parts of Africa, one of them known as Kaffir corn.

Diabase, diorite or greenstone, a fine-grained crystalline-granular rock.

Diabétes, a disease of which the most remarkable symptoms are: a great increase in the quantity of urine, a voracious appetite, a stoppage of the cutaneous perspiration, thirst, emaciation, and great muscular debility. In true diabetes (*diabetes mellitus*) the composition of the urine is also greatly affected, an abundance of saccharine matter (diabetic sugar) being found in it. This disease usually attacks persons of a debilitated constitution and often without any obvious cause. With respect to treatment a diet should be employed of which farinaceous or saccharine matter (starch and sugar) forms no part, ordinary bread or biscuits, rice, arrow-root, pastry, and fruits being accordingly forbidden, though almost any kind of

animal food, including eggs, cheese, butter, cream, &c., as also various vegetables may be eaten. Tea, coffee, dry wines, spirits, and bitter ale may be drunk. Milk should be taken only sparingly. The disease is essentially a chronic one, though death may occur with great rapidity. Diseases of the lungs are liable to attack a diabetic person.

Diabetic Sugar, the sweet principle of diabetic urine. It is identical with starch-sugar, grape-sugar, &c. It is a constant though trifling constituent of healthy urine, but in diabetes amounts to 8 or 10 per cent, and in some cases more.

Diablerets (dē-áb-lé-rā), LES, a mountain group of the Bernese Alps, Switzerland, between canton Vaud and canton Valais. The highest peak has a height of 10,620 ft.

Diacautics. See *Caustic* (in optics).

Diachylon (dī-ak'i-lon), a substance prepared by heating together oxide of lead or litharge, olive-oil, and water, until the combination is complete, and replacing the water as it evaporates. It is used for curing ulcers, and is the basis of many plasters.

Diacous'tics, the science or doctrine of sounds as they are refracted by passing through different mediums.

Diadelphía, the name given by Linnæus to his seventeenth class of plants, distinguished by having their stamens united in two bundles by their filaments.

Di'adem, an ancient ornament of royalty. It was originally a head-band or fillet made of silk, linen, or wool, worn round the temples and forehead, the ends being tied behind and let fall on the neck, as seen in old representations of the diadem of the Indian Bacchus. Latterly it was usually set with pearls and other precious stones. The term is also used as equivalent to crown or coronet.

Diæ'resis, a separation of one syllable into two, also the mark (· ·) by which this separation is distinguished, as in *aërial*.

Diaglyph'ic, a term applied to sculpture, engraving, &c., in which the objects are sunk into the general surface.

Diagno'sis, in medicine, the discrimination of diseases by their distinctive marks or symptoms; the discovery of the true nature and seat of a disease.

Diag'on'al, in geometry, a straight line drawn between the opposite angles of a quadrilateral figure.

Diag'on'al Scale, a scale which consists of a set of parallel lines drawn on a ruler, with lines crossing them at right angles and at

equal distances. One of these equal divisions, namely, that at the extremity of the ruler, is subdivided into a number of equal parts, and lines are drawn through the points of division obliquely across the paral-

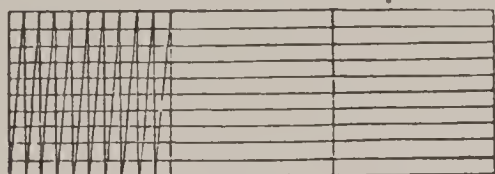

Diagonal Scale.

els. With the help of the compasses such a scale facilitates the laying down of lines of any required length to the 200th part of an inch.

Diag'oras, ancient Greek poet and philosopher, flourished about 425 B.C. He spent a great part of his life in Athens. Like his teacher Democritus, he attacked the prevailing polytheism, and sought to substitute the active powers of nature for the divinities of the Greeks. On this account he had to leave Athens.

Di'agram, a figure or geometrical delineation applied to the illustration or solution of geometrical problems, or any illustrative figure in which outlines are chiefly presented, and the details more or less omitted.

Dial, or **SUN-DIAL**, an instrument for showing the hour of the day from the shadow thrown while the sun is shining by a *stile* or *gnomon* upon a graduated surface. This instrument has been known from the earliest times amongst Egyptians, Chaldeans, and Hebrews. From those eastern nations it came to the Greeks. It was introduced into Rome during the first Punic war. Dials are of various construction, horizontal, inclined, or upright, the principle in every case being to show the sun's distance from the meridian by means of the shadow cast by the stile or gnomon. The stile is made parallel with the earth's axis, and may be considered as coinciding with the axis of the diurnal rotation. Consequently as the sun moves westwards the shadow of the stile moves round in the opposite direction, falling on the meridian lines so marked as to represent the hours of the day. The dial of course gives solar time, which, except on four days of the year, is slightly different from that of a well-regulated clock. Dials are now rather articles of curiosity or ornament than of use.

Di'alec't, the language of a part of a country, or a distant colony, deviating either in

its grammar, vocabulary, or pronunciation, from the language of that part of the common country whose idiom has been adopted as the literary language, and the medium of intercourse between well-educated people. Although the use of provincial dialects becomes inconvenient after a language has acquired a fixed literary standard, the study of such dialects is always valuable to the philologist for the light they throw on the history of the language. The diffusion of education and of printed books has much relaxed the hold which the provincial dialects of various countries once had of the people, and in general it may be said that the educated classes of any country now speak each of them a uniform language.

Dialec'tics, the old name of logic, or the art of reasoning, but used in Kant's philosophy to mean the logic of appearance, or that logic which treats of inevitable tendencies towards error and illusion in the very nature of reason.

Di'allage, a silico-magnesian mineral of a lamellar or foliated structure. Its sub-species are green diallage, hypersthene, and bronzite. The metalloidal sub-species is called schillerstein, or schiller spar. It forms diallage rock, and enters into serpentine.

Dialling, the art of making sun-dials; also the art and practice of mine-surveying, in which the theodolite, magnetic needle, &c., are employed.

Di'alogue, a conversation or discourse between two or more persons. The word is used more particularly for a formal conversation in theatrical performances, and for a written conversation or composition, in which two or more persons carry on a discourse. This form was much in favour amongst the ancient philosophers as a medium for expressing their thoughts on subjects. The Dialogues of Plato are the finest example. Many of the great French and Italian writers have used this form. Landor's Imaginary Conversations is the best production of this kind in English.

Dial'ysis, the separation of the *crystalloid* constituent elements of a mixture from the *colloid*, the former being bodies which diffuse readily, such as sugar, salt, bichromate of potassium, &c.; the latter bodies which diffuse with difficulty or not at all, bodies resembling glue or gelatin, such as gum, starch, caramel, albumen, the ordinary constituents of food, &c. &c. The dialysis is effected by pouring a mixed solution of

crystalloid and colloid on a sheet of parchment paper stretched over a wood or gutta-percha hoop, having its edges well drawn up, and confined by an outer rim. The parchment is allowed to float on a basin of water. In a short time all the crystalloid bodies will have passed through the membranous septum into the pure water, while the colloid matter will remain almost entirely in the dialyser.

Diamagnet'ic, a term applied to substances which, when under the influence of magnetism and freely suspended, take a position at right angles to the magnetic meridian, that is, point east and west. From the experiments of Faraday it appears that all matter is subject to the magnetic force as universally as it is to the gravitating force, arranging itself into two great divisions, the *paramagnetic* and *diamagnetic*. Among the former are iron, nickel, cobalt, platinum, palladium, titanium, and a few other substances; and among the latter are bismuth, antimony, cadmium, copper, gold, lead, mercury, silver, tin, zinc, and most solid, liquid, and gaseous substances. When a paramagnetic substance is suspended freely between the poles of a powerful horse-shoe magnet it points in a line from one pole to the other, which Faraday terms the *axial line*. On the other hand, when a diamagnetic substance is suspended in the same manner it is repelled alike by both poles, and assumes an equatorial direction, or a direction at right angles to the axial line.

Diamanti'na, a town, Brazil, in the diamond district in the province of Minas Geraes, the inhabitants of which are almost all engaged in the gold and diamond trade. Pop. about 6000.

Diam'eter, the straight line drawn through the centre of a circle, and touching the two opposite points of the circumference. It thus divides the circle into two equal parts, and is the greatest chord. The length of the diameter is to the length of the circumference of the circle as 1 to 3.14159265 . . . , the latter number being an interminable decimal.

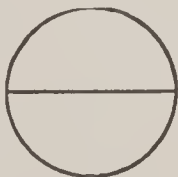

Diameter.

Di'amond, the hardest and one of the most valuable of gems, and the purest form in which the element carbon is found. (See *Carbon*.) It crystallizes in forms belonging to the regular or cubic system, the most common being the regular octahedron and rhombic dodecahedron (twelve faces). The

finest diamonds are colourless, perfectly clear, and pellucid. Such are said to be of the finest *water*. But diamonds are often blue, pink, green, or yellow, and such are highly prized if of a decided and equal tint throughout. The hardness of the diamond is such that nothing will scratch it, nor can it be cut but by itself. The value of a diamond is much enhanced by cutting facets upon it inclined at certain angles to each other so as to produce the greatest possible play of colour and lustre. What is called the *brilliant* cut best brings out the beauty of the

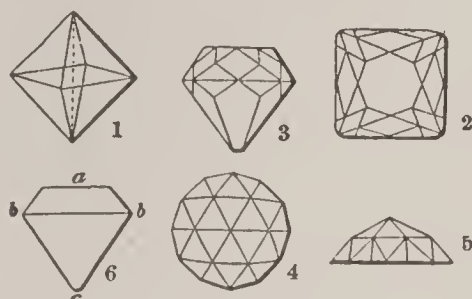

Diamonds, rough and variously cut.

stone. Its upper or principal face is octagonal, surrounded by many facets. But this form of cutting requires an originally well-shaped stone. For other diamonds the *rose* cut is used. In this form six triangles are cut on the top so that their apices meet in a point called the summit. Round this are disposed other facets. Stones which are too thin to cut as rose-diamonds are cut as *table*-diamonds, which have a very slight play of colour. In the cut fig. 1 is the diamond in its rough state; fig. 2 is the vertical, and fig. 3 the lateral appearance of a brilliant; fig. 4 the vertical, and fig. 5 the lateral appearance of a rose-cut diamond; in fig. 6 the flat portion *a* in a cut stone is called the *table*; the part *a b b*, which projects from the setting, is the *front*, the part *b b c*, sunk in the setting, is the *back* or *culasse*, while the line *b b* is the *girdle*. The art of cutting and polishing the diamond was unknown in Europe till the 15th century, and the stone itself was not nearly so highly valued in the middle ages as the ruby. Diamonds are valuable for many purposes. Their powder is the best for the lapidary, and they are used for jewelling watches, as lenses for microscopes, and in the cutting of window and plate glass. When used as a glazier's tool the diamond must be uncut. Inferior kinds of diamonds are also extensively used by engineers in rock-boring (see *Boring*), and by copperplate engravers as etching-points. Diamonds are obtained from

alluvial deposits (sands, clays, &c.), being separated by washing. They are found in India, Borneo, and other parts of the East; sometimes in N. America and Australia; but the chief diamond fields of to-day are Brazil and Cape Colony, the centre of the latter being Kimberley in Griqua Land West. Diamonds were discovered in the latter only in 1867, but since then the output has amounted to over £40,000,000 in value. One of the largest diamonds known (weight 367 carats) was found in Borneo about a century ago, and belongs to the Rajah of Mattan. One of the most celebrated is the Koh-i-noor (Mountain of Light), belonging to the British crown. It weighed originally nearly 800 carats, but by subsequent recuttings has been reduced to $103\frac{3}{4}$ carats. The Orloff diamond, belonging to the Emperor of Russia, weighs 195 carats; the Pitt diamond, among the French crown jewels, $136\frac{1}{2}$. The former, which came from India, has been thought to have originally formed part of the Koh-i-noor stone. Some of the S. African diamonds are also very large, one of them (of inferior colour) weighing 428 carats. Recently, by an expensive process, minute crystals of diamond have been artificially produced.

Diamond, in technical language, is the rhomboid—that is, a quadrangle with equal sides and two obtuse angles.

Diamond-beetle, the *Entimus imperialis*, a splendid coleopterous insect belonging to the family Curculionidæ or weevils.

Diamond-drill. See *Boring*.

Diamond Harbour, a port on the left bank of the Hugli river, about 38 miles by the railway from Calcutta, formerly much used as an anchorage for ships waiting for the tide.

Diamond Necklace, an affair of some note in French history immediately preceding the Revolution. See *Antoinette, Marie; La Motte; and Rohan, Louis*.

Dian'a, in mythology, an ancient Italian goddess whom the Romans latterly identified with the Greek Artēmis, with whom she had various attributes in common, being the virgin goddess of the moon and of the chase, and having as attributes the crescent moon, bow, arrows, and quiver. The name is a feminine form of Janus. She seems to have been originally the patron divinity of the Sabines and Latins. She was worshipped especially by women as presiding over births, no man being allowed to enter her temple. See *Artemis*.

Diana-monkey (*Cercopithēcus Diana*), a species of monkey found in Africa, and so named from the crescent-shaped band on



Diana.—Antique statue in the Louvre

the forehead resembling the crescent moon, which was the symbol of Diana.

Diana of Poitiers, Duchess of Valentinois, born in 1499. She was the mistress of King Henry II. of France, and descended from the noble family of Poitiers, in Dauphiny. At an early age she married the Grand-seneschal of Normandy, Louis de Brezé, became a widow at thirty-one, and some time after the mistress of the young Duke of Orleans. On his accession to the throne, in 1547, as Henry II., Diana continued to exercise an absolute empire over him till his death in 1559. After that event she retired to her castle of Anet, where she died in 1566.

Dian'dria, the second class in the Linnæan system, comprehending all genera with flowers having only two stamens, provided the stamens are neither united at their base, nor combined with the style and stigma, nor separated from the pistil.

Dian'thus, the genus of flowers to which the pink belongs.

Diap'ason, in music, the concord of the first and last notes of an octave. The word is also used for the most important foundation-stops of an organ. They are of several kinds, as *open diapason*, *stopped diapason*, *double diapason*. The French use the term as equivalent to pitch in music.

Di'aper, a kind of textile fabric much used for towels and napkins, and formed either of linen or cotton, or a mixture of the two, upon the surface of which a flowered or figured pattern is produced by a peculiar mode of twilling.—As a term in ornamentation diaper is applied to a surface covered with a flowered pattern sculptured in low relief, or to a similar pattern in painting or gilding covering a panel or flat surface.

Diaphoret'ics are agents used in medical practice for producing a greater degree of perspiration than is natural, but less than in sweating. The Turkish bath and a large part of hydropathic treatment, diluent drinks, &c., are employed for this purpose. *Diaphoretics* increase only the insensible perspiration, while *sudorifics* excite the sensible discharge called sweat.

Diaphragm (dī'a-fram), in anatomy, a muscular membrane placed transversely in the trunk, and dividing the chest from the abdominal cavity. In its natural situation the diaphragm is convex on the upper side and concave on its lower, but when the lungs are filled with air it becomes almost flat. It is the principal agent in respiration, particularly in inspiration. A complete diaphragm is found only in Mammalia.

Diarbek'ir, a town, Asiatic Turkey, capital of the pashalic of same name, on a high bank overlooking the Tigris, and surrounded by a lofty massive wall. It has manufactures of iron and copper ware, leather, silk, woollen, and cotton goods, and a considerable trade. Pop. about 40,000.

Diarrhœ'a, a very common disease, which consists in an increased discharge from the alimentary canal, the evacuations being but little affected, except in their assuming a more liquid consistence. They are generally preceded or accompanied by flatulence and a griping pain in the bowels, and frequently by sickness. Diarrhœa is often produced by indigestible food, repletion of the stomach, cold applied to the surface of the body, impressions on the nervous system. It is often also a symptom of some other disease. In its simple form diarrhœa is not difficult of cure, mild purgatives given in small doses and accompanied by quantities of mild diluents being frequently successful. Castor-oil, rhubarb, magnesia are the most generally applicable. The food should be of the least stimulating kind.

Di'astase, a substance existing in barley, oats, and potatoes, but only after germination. When in solution it possesses the pro-

perty of causing fecula or starch to break up at the temperature of 150° Fahr., transforming it first into dextrine and then into sugar. It is obtained by digesting in a mixture of three parts of water and one of alcohol, at a temperature of 113° Fahr., a certain quantity of germinated barley ground and dried in the open air, and then putting the whole under pressure and filtering it. Diastase is solid, white, and soluble in water and diluted alcohol, but insoluble in strong alcohol.

Diather'mancy, the property that is possessed in various degrees by different substances of transmitting radiant heat. Bodies that are equally transparent, that is, bodies which have equal power of transmitting rays of light, are very different in their power of transmitting heat rays. Thus a thin plate of glass and a thin plate of rock-salt may be nearly equally transparent, but the plate of rock-salt has far superior power of transmitting rays of heat. The latter, it has been found, allows 92 per cent of the total heat from any source to pass; glass only 39 per cent from a lamp flame, 24 per cent from incandescent platinum, &c. Rock-salt is the only body equally diathermanous to heat from all sources. The diathermancy of the plates in every case decreases very rapidly as their thickness is increased.

Diath'esis, in medicine, a certain general habit or constitution of body as predisposing to certain diseases.

Diatoma'ceæ, a natural order of confervoid algæ, consisting of microscopic plants found in fresh, brackish, and salt water, and on moist plants and damp ground. The frond secretes a very large quantity of silex, which is formed in each cell into three portions, viz., two generally symmetrical valves and a connecting hoop. The species consist of single free cells, or the cells remain attached so as to form linear, flabelliform, circular, or geniculate fronds, or in some cases the cells or frustules are inclosed in a transparent gelatinous sheath or frond. The ordinary method of increase is by cell division. Diatomaceæ are found fossil, forming considerable deposits of tertiary age, as at Bilin, Richmond in the United States, &c. Fossil polishing powders, as tripoli and bergmehl, are composed of them. They are abundant in guano.

Diat'omite, a diatomaceous earth (see *Diatomaceæ*) generally found underlying peat in various districts of Scotland. In Skye, at Loch Quire, where large supplies of diatomite

have recently been discovered, it is found about 18 inches below the surface, and extends downward for about 7 feet, and in some places to a much greater depth. Diatomite is principally used for the manufacture of dynamite, its value as an absorbent being fully double that of the ordinary German Kieselguhr. It is described also as extremely well adapted for the manufacture of silicate and ultramarine paints, siliceous glazings, porcelain, boiler-coatings, isolating felt, &c.

Diatonic, a term originally applied by the Greeks to one of their three genera of music. In modern music it is applied to the natural scale, and to the intervals, chords, melodies, or harmony characteristic of it. A diatonic chord is a chord having no note chromatically altered. A diatonic interval is an interval formed by two notes of the diatonic scale unaltered by accidentals. A diatonic melody is a melody composed of notes belonging to one scale only.

Diaz, BARTOLOMEO, a celebrated Portuguese navigator of the 15th century, named in 1486 commander of one of that long succession of exploratory expeditions which the Portuguese court had during this century become distinguished for promoting. The two vessels composing the expedition sailed along the African coast till they reached Cape Negro (lat. 15° 50' s.), where Diego Cam, a previous explorer, had stopped. At 29° s. they anchored at a point to which they gave the name of Angra das Voltas (Bay of Detours). In sailing south from this point they doubled the Cape of Good Hope without knowing it, and landed at a bay on the east coast. Diaz now wished to continue his voyage in order to discover the country of Prester John, but the sailors refused to accompany him. In again doubling the Cape he gave it the name of Cabo Tormentoso (Cape of Storms), which the king changed to its present designation. In 1500 Diaz had command of a vessel in the expedition of Cabral which discovered Brazil. In returning home the vessel which he commanded was lost, 29th May, 1500.

Dib'din, CHARLES, an English dramatic manager and poet, composer and actor, born in 1745, died in 1814. At the age of fifteen he made his appearance on the stage, and was early distinguished as a composer. He invented a new kind of entertainment, consisting of music, songs, and public declamations, which he wrote, sung, composed, and performed, himself, and by this means suc-

ceeded in amusing the public for twenty years. His patriotic songs were very popular, and his sea-songs, amongst which are Tom Bowling, Poor Jack, and The Trim-built Wherry, are still favourites in the British navy.—His son, CHARLES DIBDIN, composed and wrote many small pieces and occasional songs.—Another son, THOMAS, early displayed the same dramatic tastes as his father, was connected with various theatres, and wrote a great many songs and a number of dramas.

Dibdin, THOMAS FROGNAL, an English bibliographer, born in 1776, died in 1847, was the son of the elder brother of Charles Libdin the celebrated naval song-writer. After studying law and practising as a provincial counsel he took orders and became a popular preacher in London. Here his bibliographical tastes developed themselves, and the Roxburghe Club being established in 1812, he became its first vice-president. Among his numerous writings may be noted *Bibliomania*; *Bibliographical Decameron*; *Typographical Antiquities of Great Britain*.

Dibranchia'ta, the two-gilled Cephalopods or cuttle-fishes. See *Cephalopoda*.

Dice, cubical pieces of bone or ivory, marked with dots on each of their six faces, from one to six, according to the number of faces. They are shaken in a small box and then thrown on the table. Dice are often loaded or falsified in some way so as to make the high or the low sides turn down. Dice are very ancient, being well known amongst the Egyptians and Greeks.

Dichlamydeous (di-klam-id'i-us), in botany, said of plants that have both calyx and corolla.

Dichobune (di-ko-būn'), a genus of extinct quadrupeds occurring in the Eocene formations, presenting marked affinity to the ruminants, and coming between them and the Anoplotherium.

Dichotomy (di-kot'o-mi), a cutting in two; a division by pairs. Hence, in botany, a mode of branching by constant forking, each branch dividing into two others.

Dichroic Crystals (di-krō'ik), crystals that have the property of exhibiting different colours when polarized light is passed through them in different directions. Thus *dichroite*, a mineral observed by Haiüy, appears deep-blue in the direction of the principal axis, and yellowish-brown in a direction at right angles to it, even when viewed with ordinary light.

Dichroite (di'kro-it), a mineral, a silicate of magnesium, iron, and aluminium, which readily undergoes modifications and passes into other minerals. It exhibits different colours. (See preceding article.) Sometimes called *Iolite*.

Dichroscope (di'kro-skōp), an optical instrument, usually consisting of an achromatized double-image prism of Iceland-spar, fixed in a brass tube, which has a small square hole at one end and a convex lens at the other, of such a power as to give a sharp image of the square hole. On looking through the instrument the square hole appears double, and if a dichroic crystal is placed in front of it the two images will appear of different colours. See *Dichroic*.

Dick, THOMAS, LL.D., a Scottish author of popular scientific works, born at Dundee in 1774. He was for many years a teacher at Perth, but latterly resided at Broughty-Ferry, where he devoted himself to astronomical science, especially in its relations to religion. Some years before his death a small pension was granted to him by the government. Amongst his works are *The Christian Philosopher* (1823), *Celestial Scenery* (1838), &c. He died 29th July, 1857.

Dick Bequest, a bequest of over £100,000 left in 1828 by James Dick, a native of Morayshire, and latterly a merchant in London, for the encouragement of education in the parochial schools of the counties of Moray, Banff, and Aberdeen. In order to qualify for getting a share in the revenue of the fund, teachers have to pass a searching examination, and the amount received each year depends on the state of the schools, the subjects taught, &c. The sums distributed yearly thus vary considerably, the average for each teacher being about £30.

Dickens, CHARLES, one of the greatest English novelists, was born February 7th, 1812, at Landport, Portsmouth. His father, John Dickens, was then in the employment of the Navy Pay Department, but subsequently became a newspaper reporter in London. Young Dickens received a somewhat scanty education, was for a time a mere drudge in a blacking warehouse, and subsequently a clerk in an attorney's office. Having perfected himself in shorthand, however, he became a newspaper critic and reporter, was engaged on the *Mirror of Parliament* and the *True Sun*, and in 1835 on the *Morning Chronicle*. For some time previously he had been contributing humorous

pieces to the *Monthly Magazine*; but at length, in 1835, appeared in the *Morning Chronicle* the first of that series of Sketches by Boz which brought Dickens into fame. It was followed in quick succession by a pamphlet entitled *Sunday under Three Heads*, by Timothy Spark (1836); the *Tuggs of Ramsgate* (1836); *The Village Coquette*, a comic opera (1836); and a farce called *the Strange*



Charles Dickens.

Gentleman (1836). In the same year Chapman and Hall engaged the new writer to prepare the letterpress for a series of comic sketches on sporting subjects by Seymour, an artist who had already achieved fame, and suggested as a subject the adventures of an eccentric club. Seymour committed suicide soon after, and H. K. Browne joined Dickens as illustrator, the result being the immortal *Pickwick Papers*. The great characteristics of Dickens' genius were now fully apparent, and his fame rose at once to the highest point it was possible for a writer of fiction to reach. A new class of characters, eccentric indeed, but vital representations of the humours and oddities of life, such as Mr. Pickwick, Sam Weller and his father, Mr. Winkle, and others, were made familiar to the public. Under the name of the *Posthumous Papers of the Pickwick Club* this work was published in two vols. 8vo in 1837. In the same year Dickens was engaged as editor of *Pentley's Magazine*, to which he contributed *Oliver Twist*, a work which opened up that vein of philanthropic pathos and indignant satire of institutions which became a distinguishing feature of his works. Before the completion of *Oliver*

Twist, Nicholas Nickleby was begun, being issued complete in 1839. As the special object of Oliver Twist was to expose the conduct of workhouses, that of Nicholas Nickleby was to denounce the management of cheap boarding-schools. Master Humphrey's Clock, issued in weekly numbers, contained among other matter two other leading tales, The Old Curiosity Shop, and Barnaby Rudge, the latter a historical tale, going back to the times of the Gordon riots. It was published complete in 1840-41. In 1841 Dickens visited America, and on his return he wrote American Notes for General Circulation (1842). His next novel, Martin Chuzzlewit (1844), dwelt again on his American experiences. This work also added a number of typical figures—Mr. Pecksniff, Mark Tapley, Sarah Gamp, and others—to English literature. The series of Christmas Tales, in which a new element of his genius, the power of handling the wierd machinery of ghostly legend in subordination to his own peculiar humour, excited a new sensation of wonder and delight. These enumerated consecutively were: A Christmas Carol (1843), The Chimes (1844), The Cricket on the Hearth (1845), The Battle of Life (1846), The Haunted Man and the Ghost's Bargain (1847). The extraordinary popularity of these tales created for a time a new department in literature, that of the sensational tale for the Christmas season. In 1845 Dickens went to Italy, and on his return the Daily News, started on 1st January, 1846, was intrusted to his editorial management; but, despite his early training, this was an occupation uncongenial to his mind, and in a few months the experiment was abandoned. His Pictures from Italy were published the same year. Next followed his novel of Dombey and Son (1848), and David Copperfield, a work which has a strong autobiographical element in it (1849-50). In 1850 Dickens became editor of the weekly serial Household Words, in which various original contributions from his own pen appeared. In 1853 his Bleak House came out. A Child's History of England, commenced in Household Words, was published in 1852-54. Hard Times appeared in Household Words, and was published in 1854. Little Dorrit, commenced in 1856, dealt with imprisonment for debt, the contrasts of character developed by wealth and poverty, and executive imbecility, idealized in the Circumlocution Office. In 1859, in consequence of a disagreement with his pub-

lishers, All the Year Round superseded Household Words; and in the first number of this periodical, 28th May, was begun A Tale of Two Cities. Great Expectations followed in the same paper, on 1st December, 1860. Both were soon republished, and are generally considered as the poorest of Dickens' works. In All the Year Round also appeared a series of disconnected sketches, called the Uncommercial Traveller, published in 1868. Our Mutual Friend, completed in 1865, and published in the usual monthly numbers, with illustrations by Marcus Stone, was the last great serial work which Dickens lived to finish. It contained some studies of characters of a breadth and depth unusual with Dickens, and is distinguished among his works by its elaborate plot. The first number of his last work, The Mystery of Edwin Drood, was issued on 1st April, 1870, and only three numbers had appeared when he died somewhat suddenly, at his residence, Gad's Hill Place, near Rochester, on 9th June. He had considerably overtaxed his strength during his later years, more especially by his successive series of public readings from his own works, one series being delivered in America in 1867-68. He was buried in Westminster Abbey. Dickens' work as a novelist is firmly based upon a wide and keen observation of men. It is true that most of his characters suffer from being created to exhibit little more than one trait or quality alone, and thus receive an air of grotesqueness and exaggeration which approaches caricature. But the single trait or quality which they embody is so truly conceived, and exhibited with such vitality and humour, as to place Dickens, in spite of all that is grotesque and overstrained in his work, amongst the great artists.

Dicotyledon (di-kot-i-lē'don), a plant whose seeds are characterized by the embryo containing a pair of cotyledons or seed-leaves, which are always opposite to each other. Dicotyledons are further characterized by their netted-veined leaves and the exogenous structure of their stems. The class is divided into four sub-classes: Thalamifloræ, Calycifloræ, Corollifloræ, and Monochlamydeæ (which see respectively). The class receives also the name of *exogens*.

Dicta'tor, an extraordinary magistrate of the Roman Republic, first instituted B.C. 501. The power of naming a dictator when an emergency arose requiring a concentration of the powers of the state in a single

superior officer, was vested by a resolution of the senate in one of the consuls. The dictatorship was limited to six months, and the person who held it could not go out of Italy. This rule was laid aside during the first Punic war. The dictator was also forbidden to appear in Rome on horseback without the permission of the people, and he had no control over the public funds without the permission of the senate. He had the power of life and death, and could punish without appeal to the senate or people. All the other magistrates were under his orders.

Dictionary (from the Latin *dictio*, a saying, expression, word), a book containing the words, or subjects, which it treats, arranged in alphabetical order. It may be either a vocabulary, or collection of the words in a language, with their definitions; or a special work on one or more branches of science or art prepared on the principle of alphabetical arrangement, such as dictionaries of biography, law, music, medicine, &c. Amongst dictionaries of the English language, the earliest seem to have been those of Baret, 1573, and of Bullokar (1616). That of Dr. Johnson published in 1755 made an epoch in this department of literature. Previous to this the chief English dictionary was that of Bailey, a useful work in its way. An enlarged edition of Johnson's dictionary, by the Rev. H. J. Todd, appeared in 1818; and this, again enlarged and modified, was issued under the editorship of Dr. R. G. Latham (1864-72). The chief American dictionary of the English language is that by Noah Webster first published in 1828. It has been frequently republished, and in subsequent editions has almost entirely altered its character. Dr. Richardson's dictionary, first published in two vols. in 1836-37 (at London), is valuable chiefly for its copious illustrative quotations. The large American dictionary by Dr. Worcester has made a good position for itself. Dr. Ogilvie's English dictionary (based on Webster, and first published in 1847-50) has recently been published in a remodelled and enlarged form (4 vols. 1881-82, Chas. Annandale, LL.D., editor). Cassell's Encyclopædic Dictionary is another extensive and useful work (1879-88). A new English dictionary 'on historical principles,' edited by J. A. H. Murray, LL.D., with the assistance of many scholars, is being published at the Clarendon Press (*A—Cassowary*, 1884-91). It will be the most exhaustive and thorough

of all English dictionaries. The *Century Dictionary* (New York, 1889-91) in 6 vols. is the latest finished work in English lexicography on a large scale. The chief etymological dictionary of English words is that by Prof. Skeat (1882); the chief French is that of Littré; German, that of Grimm.

Dic'tyogens, the name given by Lindley to a group of monocotyledonous plants, with net-veined leaves, intermediate between the monocotyledons and dicotyledons; as the yam, sarsaparilla, &c.

Didactic Poetry, that kind of poetry which professes to give a kind of systematized instruction on a definite subject or range of subjects. Thus the Georgics of Virgil and the De Rerum Natura of Lucretius profess to give, the one a complete account of agriculture and kindred arts, the other a philosophical explanation of the world. In a larger sense of the word most great poems might be called didactic, since they contain a didactic element in the shape of history or moral teaching, Dante's Divina Commedia, Milton's Paradise Lost, or Goethe's Faust, for example. The difference may be said to be this, that in the one case the materials are limited and controlled by nothing but the creative fancy of the poet, while in the other they are much more determined by the actual nature of the subject treated of.

Didel'phia, one of the three sub-classes of the Mammalia (the others being Monodelphia and Ornithodelphia), comprising the order otherwise known as Marsupials, which form the only order in the sub-class.

Didelphys. See *Opossum*.

Diderot (dēd-rō), DENIS, a French writer and philosopher, was born in 1713, at Langres, in Champagne, and educated in the school of the Jesuits, and afterwards at Paris, at the College of Harcourt. His first works were the *Essai sur le Mérite et la Vertu* (1745); and the *Pensées Philosophiques* (1746), a pamphlet against the Christian religion. His *Lettre sur les Aveugles à l'Usage de Ceux qui Voyent*, is in the same strain. These heterodox publications cost him an imprisonment for some time at Vincennes. Diderot now tried writing for the stage, but his pieces were failures. In 1749 he had begun along with D'Alembert and some others the Encyclopædia. At first it was intended to be mainly a translation of one already published in English by Chambers. Diderot and D'Alembert, however, enlarged upon this project, and made

the new Encyclopædia a magnificently comprehensive and bold account of all the thought and science of the time. Diderot, besides revising the whole, undertook at first the mechanical arts, and subsequently made contributions in history, philosophy, and art criticism. But the profits of all his labour were small, and it was only the liberality of the Empress Catharine, who purchased his library for 50,000 livres and made him a yearly allowance of 1000 livres, that saved Diderot from indigence. In 1773 he visited St. Petersburg to thank his benefactress and was received with great honour. On his return to France he lived in retirement, and died in 1784. Besides his articles in the Encyclopædia he wrote numerous works, some of which were published after his death. Among the best known are *Le Neveu de Rameau*, a kind of philosophical dialogue which Goethe thought worthy of translation; *Essai sur la Peinture*, and *Paradoxe sur le Comédien*, suggestive essays on the principles of painting and acting; two lively tales, *La Religieuse* and *Jacques le Fataliste*.

Dido, or **ELISSA**, the reputed founder of Carthage. She was the daughter of a king of Tyre, and after her father's death her brother Pygmalion murdered her husband Sicharbas, or as Virgil calls him Sichæus, with the view of obtaining his wealth. But Dido, accompanied by many Tyrians of her party, fled with all the treasure over sea, and landing on the coast of Africa founded Carthage about 860 B.C. The story is told by Virgil with many inventions of his own in the *Æneid* (books i. and ii.).

Didot (dē-dō), a famous house of printers, booksellers, and typefounders at Paris. The founder was FRANÇOIS DIDOT, born in 1689, died 1757. Of his sons FRANÇOIS-AMBROISE (born 1720, died 1804) and PIERRE-FRANÇOIS (born 1732, died 1795) the first distinguished himself in the type-founding art as an inventor of new processes and machines, the second was equally eminent by his bibliographical knowledge, and contributed much also to the advancement of printing. PIERRE (born 1761, died 1853) succeeded his father François-Ambroise in the printing business. He made himself famous by his magnificent editions of classic authors in folio, amongst which his Virgil (1798) and his Racine (1801) may be particularly mentioned. He did much also for the improvement of types, &c. He is known also as an author.—FIRMIN (born 1764, died 1836), the brother of Pierre, took charge of the type-

founding, was the inventor of a new sort of script, and an improver of the stereotype process.—AMBROISE-FIRMIN (born 1790, died 1876) and HYACINTHE-FIRMIN (born 1794, died 1880) occupied a distinguished position amongst the publishers of Paris. The house has now extended its trade into everything connected with bookselling, paper-making, book-binding, &c.

Didun'culus, a genus of birds allied to the pigeons, and comprising only the one species, *D. strigirostris* of the Navigator Islands.



Didunculus strigirostris.

This bird is of special interest as being the nearest living ally of the extinct dodo. It has a length of about 14 inches, with a glossy plumage verging from a velvety black on the back to greenish black on the head, breast, and abdomen. The large beak, which is nearly as long as the head, is greatly arched on the upper half, while the lower is furnished with two or three tooth-like indentations.

Didym'ium, a rare metallic element, occurring along with *lanthanum* in the mineral cerite as discovered by Mosander in 1843. Recently it is said to have been resolved into two new elements: *Praseodymium* and *Neodymium*.

Didyna'mia, the fourteenth class in the Linnæan system of plants, the members of which have four stamens, of which two are longer than the other two.

Die, a metallic stamp for impressing a design or figure upon coins or other metallic objects. See *Die-sinking*.

Die (dē), an ancient town, France, dep. Drôme, 26 miles south-east of Valence; with a former cathedral and Roman remains. Pop. 3298.

Dié (di-ā), St., a town, France, dep. of Vosges, on the Meurthe, 25 miles E.N.E. of Epinal. Both iron and copper are worked;

there are marble quarries; and a variety of manufactures are carried on. Pop. 12,961.

Diebitsch-Sabalkanski, HANS KARL, a Russian general, born at Grossleippe in Silesia in 1785, was educated at the military school of Berlin, but in 1801 quitted the Prussian service for that of Russia. He was present at the battles of Austerlitz and Friedland, served with distinction in the campaign of 1812, took part in the battles of Dresden and Leipzig, and was made lieutenant-general at the age of twenty-eight. He had the chief command in the Turkish war of 1828-29, stormed Varna, and made the famous passage of the Balkans, for which the surname of Sabalkanski was conferred on him. In 1830 he commanded the army sent against the revolted Poles, but did not distinguish himself in this service. He died 9th June, 1831.

Diedenhofen (dē'den-hō-vn). See *Thionville*.

Dieffenbach (dē'fen-bāh), JOHANN FRIEDRICH, German surgeon, born at Königsberg in 1792. After having studied at Bonn and Paris he settled in Berlin, where his talent as an operator soon attracted notice. Surgery is particularly indebted to him for new methods of forming artificial noses, eyelids, lips, &c., and curing squinting, stammering, &c. He died in 1847.

Dieffenbachia (dēf-en-bak'i-a). See *Dumb-cane*.

Di'electric, a name applied by Faraday to any medium through or across which electrostatic induction can take place. (See *Induction*, *Electrostatic*.) Faraday first showed that electrostatic induction was not action at a distance, but took place by means of the insulating medium separating the two conductors. The medium he named a *dielectric*, and measured its specific inductive capacity by taking that of common air as unity.

Diëly'tra, a genus of plants belonging to the natural order Fumariaceæ or Fumitories. The best known is *D. spectabilis*, a native of Northern China and Siberia, now common in European and other gardens. It blossoms in April and May, and its long drooping racemes of purplish-red blossoms present a very graceful appearance. It grows freely in the open air. It is sometimes called pendent heart or virgin's heart from the shape of the blossoms.

Diemen (dē'men), ANTON VAN, Dutch administrator, was born in 1593. Having gone to India, he speedily rose to the

highest dignities, and was at length, in 1636, made governor-general. He administered the government with much ability, and contributed much to the establishment of the Dutch commerce in India. Abel Tasman, whom he sent with a vessel to the South Seas in 1642, gave the name of *Van Diemen's Land* to the island now called Tasmania. Van Diemen died in 1645.

Dieppe (dē-ep'), a seaport town, France, department Seine-Inférieure, on the English Channel, at the embouchure of the Arques, 93 miles N.N.W. Paris. Almost the only public edifices worth special notice are the two Gothic churches, St. Jacques, begun in the 13th century, and St. Rémi, founded in 1522, and the old castle (1433), now a barrack. To the west of Dieppe proper is the suburb La Barre; and on the opposite side of the harbour La Pollet, which is inhabited chiefly by sailors and fishermen. The port is spacious, admitting vessels of 1200 tons burden; but it cannot be entered at low water. Dieppe is one of the chief watering-places of France, and is much frequented by visitors in summer and autumn. The great bathing establishment forms a luxurious retreat for bathers and invalids, and includes a ball-room, &c. The manufactures include works in ivory, the most famed in Europe; works in horn and bone, lace-making, sugar-refining, ship-building, &c. There is a busy fishery, and the foreign trade is still considerable. There is constant steam intercourse between this port and Newhaven. In early times Dieppe was the chief port of France, but its prosperity diminished after the revocation of the Edict of Nantes (1685). Pop. 20,804.

Dies Fasti et Nefasti, a Roman division of days, with reference to judicial business, into working-days and holidays. A *dies fastus* was a day on which courts and assemblies could be held and judgments pronounced; a *dies nefastus*, a day on which courts could not be held nor judgments pronounced.

Die-sinking is the art of preparing dies for stamping coins, buttons, medallions, jewelry, fittings, &c. The steel for the manufacture of dies is carefully selected, forged at a high heat into the rough die, softened by careful annealing, and then handed over to the engraver. After the engraver has worked out the design in intaglio the die is put through the operation of hardening, after which, being cleaned and polished, it is called a *matrix*. This is not,

however, generally employed in multiplying impressions, but is used for making a *punch* or steel impression for relief. For this purpose another block of steel of the same quality is selected, and, being carefully annealed or softened, is compressed by proper machinery upon the matrix till it receives the impression. When this process is complete the impression is retouched by the engraver, and hardened and collared like the matrix. Any number of dies may now be made from this punch by impressing upon it plugs of soft steel. In place of this process patterns are now frequently engraved upon rollers for transference to sheet metal by rolling pressure.

Dies Iræ (dī'es ī'rē), one of the great Latin hymns of the mediæval church, generally used as part of the requiem or mass for the souls of the dead. It describes, as its name ('the day of wrath') denotes, the final judgment of the world, and seems to have been suggested by the description in Zephaniah i. 15 and 16. It is supposed to have been written by Thomas da Celano, a Franciscan friar of the 13th century. There are many translations, but hardly any which convey the solemn force of the original.

Diest (dēst), a town, Belgium, province Brabant, 32 miles E.N.E. Brussels. It has some manufactures, but the chief products of the place are beer and gin, the former being largely exported. Pop. 7599.

Di'et, a meeting of some body of men held for deliberation or other purposes; a term especially applied to the legislative or administrative assemblies of the German empire, Austria, &c.

Diet Drink, a name for various drinks or decoctions taken in considerable quantities to purify the blood.

Dietet'ics, that part of medicine which relates to the regulation of diet. The ideal diet is clearly that which, without burdening the viscera uselessly, furnishes all necessary nutritive elements, with due consideration for special physiological conditions in any given case. Under the head of *Aliment* the physiological properties of various foods have already been considered theoretically in respect of their capacity to supply physical waste in nitrogenous and non-nitrogenous matter. (See *Aliment*.) No single substance contains the elements needed to replace this waste in their requisite proportions, and a mixed diet is therefore necessary. For instance to secure the required amount of carbon a man would need to eat about 4 lbs. of

lean beef, while 1 lb. would yield all the nitrogen required; thus, apart from the labour of digesting 4 lbs. of beef, the body would be compelled to get rid of the excess of nitrogen. Bread, on the other hand, has carbon in abundance, but is deficient in nitrogen; so that by uniting 2 lbs. of bread with $\frac{3}{4}$ lb. of lean meat, the due proportion of carbon and nitrogen is satisfactorily supplied. Milk and oatmeal taken together also contain nitrogenous and non-nitrogenous substances in nearly the required proportions. A certain proportion of saline matter is also necessary. The nature of the food most suitable for a healthy man is dependent in part upon general conditions such as climate and season, and in part upon special conditions of individual habit. The inhabitants of the Arctic regions need large quantities of oleaginous food; those of the Tropics live chiefly on starchy products. With increased activity and exertion, as in training, an increase in the nitrogenous foods becomes necessary. In a state of health we need not draw hairbreadth distinctions as to the superior salubrity of the several sorts of diet, the quantity rather than the quality of food being the main consideration. Those persons who have been most remarkable for health and long life have generally been contented with two moderate meals a day, which are certainly quite sufficient during a state of health. In various countries the breakfast generally consists of tea, coffee, or cocoa, with a certain proportion of bread and butter; persons with delicate digestive powers, or who lead a sedentary life, cannot with safety or comfort eat animal food *constantly* to breakfast. At dinner all made-dishes highly spiced, such as curries, turtle-soup, &c., as provoking appetite, are hurtful; and the custom of late dining is not to be commended. Stewed and boiled meats are more difficult to digest than meat cooked by fire alone. The flesh of young animals seems to be more difficult of digestion than that of old; and the flesh of tame than that of wild animals. All sorts of fat meat must be taken in smaller quantities. Hence, also, ham, bacon, and salted meats cannot be eaten in such quantities as the tender flesh of poultry. Fish has the advantage of being easily soluble. All boiled vegetables are in general easy of digestion; raw vegetables and salads are rather more difficult. Fruit should be taken in the forenoon rather than after a hearty meal. The moderate use of fermented liquors is far from

being invariably an evil, but the smaller the quantity habitually used the better in the majority of cases.

In all diseases attended with much fever or quickness of pulse the stomach loathes animal food, and there is generally a great increase of thirst, to quench which water, either quite cold, or iced, or tepid, or rendered acid, may be freely indulged. Infusions, too, of barley, sage, balm, &c., may be taken. In chronic diseases attended with hectic fever, milk is the most proper diet. The best food for infants is, of course, their mother's milk; but whenever they begin to cut teeth a little animal food, such as soft-boiled eggs, beef-tea, and even chicken minced very fine, may be given. Many infants suffer from having too much sugar given them in their food.

Dietrich (dē'trih), CHRISTIAN WILHELM ERNST, a German painter and engraver, called by Winckelmann 'the Raphael of Landscape,' born in 1712. He studied under his father, and afterwards under Alexander Thiele at Dresden, where he became court-painter, professor in the academy, &c. He adopted several different manners, successfully imitating Raphael and Mieris, Correggio and Ostade. He died in 1774.

Dietrich of Bern (dē'trih), the name under which Theodoric the Great, king of the Ostrogoths, appears in the old German legends. Bern stands for Verona, his capital.

Dieu, or D'YEU (dyeu; ancient *Insula Dei*), an island off the west coast of France, department of Vendée. It is inaccessible on the west side, but on the east has a tolerable harbour defended by batteries. The chief industry is fishing. There are four light-houses on the island. Pop. 2929.

Dieu et Mon Droit (dyeu e mon drwä; 'God and my right'), the motto of the arms of England, first assumed by Richard I., and revived by Edward III. when he claimed the crown of France. Except during the reigns of Elizabeth and Anne, who used the motto *Semper eadem*, and of William III., who personally used *Je maintiendray*, it has ever since been the royal motto of England.

Diez (dêts), FRIEDRICH CHRISTIAN, German philologist of the Romance languages, born in 1794. Having qualified himself as a lecturer at Bonn, he was appointed professor of the Romance languages here in 1830. His work stands in much the same relation to the Romance dialects which the researches of Grimm occupy with respect to

German dialects. In addition to various works on the poetry of the Troubadours, he published a very valuable *Grammatik der Romanischen Sprachen* in 1836-42 (which has been translated into English), and an *Etymologisches Wörterbuch der Romanischen Sprachen* in 1853. He died in 1876.

Differential Calculus. See *Calculus*.

Differential Thermometer, an instrument for determining very minute differences of temperature. Leslie's differential thermometer consists of two glass bulbs containing air connected by a bent tube containing some sulphuric acid, the movement of which (as the air expands and contracts) serves to indicate any slight difference of temperature between the two bulbs.

Diffraction, a term applied to certain phenomena connected with the modification that rays of light undergo in passing close to the edge of an opaque body. Thus when a beam of direct sunlight is admitted into a dark room through a narrow slit, and falls upon a screen placed to receive it, there appears a line of white light bordered by coloured fringes; these fringes are produced by diffraction. See *Interference*.

Diffu'sion, the gradual dispersion of particles of one liquid or gas among those of another. Thus, in the case of gases, when a jar of oxygen and a jar of hydrogen are connected together by a tube or opening of any kind, they rapidly become mixed; and their mixture does not depend on gravity, but takes place in opposition to that force, as may be shown by placing the jar of hydrogen gas above the other. Oxygen is sixteen times heavier than hydrogen, bulk for bulk, but the heavier gas moves upwards and the lighter downwards, and the process of intermixture, or *diffusion*, goes on till the two gases are apparently equally distributed throughout the whole space. After that they have no tendency whatever to separate. Similarly, if two vessels, one containing oxygen and the other hydrogen, be connected by a tube which is stuffed with a plug of porous material, such as plaster of Paris, the gases gradually diffuse one into the other through the porous plug. The two gases, however, do not pass through the porous separator at equal rates, but in *inverse proportion to the square roots of the densities of the gases*. Thus in the case of two vessels, one containing hydrogen and the other oxygen, which is sixteen times as heavy as hydrogen, the hydrogen will pass

towards the oxygen jar four times as quickly as the oxygen will pass towards the hydrogen jar. Kindred phenomena occur when two liquids that are capable of mixing, such as alcohol and water, are put in contact, the two gradually diffusing one into the other in spite of the action of gravity. In some cases, however, as where ether and water are employed, the diffusion is only partial, extending a comparatively small distance on either side of the original line of separation. When solutions of various solid bodies are placed in contact, interdiffusion also takes place. On the results of his examination of the phenomena of diffusion of liquids and salts across porous membranes or *septa*, Graham founded a method of separating *colloid* from *crystalloid* bodies, which he called *dialysis* (see this art.).

Digam'ma, a letter which once belonged to the Greek alphabet, and which remained longest in use among the Æolians. It resembled our letter F, and hence was called *digamma*, that is, double Γ. It appears to have had the force of *f* or *v*.

Digby, SIR EVERARD, an English gentleman, born of a Roman Catholic family in 1581. He enjoyed some consideration at the court of Elizabeth and James I., by whom he was knighted. Having contributed money to the Guy Faux conspiracy, he was tried and hanged in 1606.

Digby, SIR KENELM, eldest son of the preceding, born in 1603. He studied at Oxford, was knighted in 1623, and on the accession of Charles I. was created a gentleman of the bed-chamber, a commissioner of the navy, and a governor of the Trinity House. He soon after fitted out at his own expense a small but successful squadron against the Algerines and Venetians. In 1636 he became a Roman Catholic, was imprisoned as a Royalist from 1638 to 1643, when he was allowed to retire to the Continent. At the Restoration he returned to England, became a member of the Royal Society, and was much visited by men of science. He died in 1665. He wrote numerous works: a Treatise on the Nature of Bodies, a Treatise on the Nature and Operation of the Soul, Of the Cure of Wounds by the Power of Sympathy, &c. Evelyn calls him 'an arrant mountebank.'

Di'gest, a name originally given to a collection or body of Roman laws, digested or arranged under proper titles by order of the emperor Justinian. Hence applied to any somewhat similar collection.

Diges'ter, a strong vessel of copper or iron, on which is screwed an air-tight cover with a safety-valve, the object being to prevent loss of heat by evaporation. Water may be thus heated to 400° Fahr.; at which temperature its solvent power is so greatly increased that bones are converted into a jelly.

Diges'tion is that process in the animal body by which the aliments are so acted upon that the nutritive parts are prepared to enter the circulation, and separated from those which cannot afford nourishment to the body. The organs effecting this process are called the *digestive* organs, and consist of the stomach, the great and small intestines, &c. (see *Intestine, Stomach*), the liver, and pancreas. When the aliments, after being properly prepared and mixed with saliva by mastication, have reached the stomach, they are intimately united with a liquid substance called the *gastric juice*, by the motion of the stomach. By this motion the aliments are mechanically separated into their smallest parts, penetrated by the gastric juice, and transformed into a uniform pulpy or fluid mass. The gastric juice acts upon the albuminous parts of the food, converting them into peptones, which can pass through organic membranes and thus enter the blood. This action is aided by the warmth of the stomach. The pulpy mass, called *chyme*, proceeds from the stomach, through the pylorus, into that part of the intestinal canal called the small intestine, where it is mixed with the pancreatic juice, bile, and intestinal juice. The pancreatic juice converts starch into sugar, albumins into peptones, and emulsionizes fats, so that all these kinds of food are rendered capable of absorption. The process is aided by the intestinal juice. The bile also acts upon fats, and thus the food is formed into the *chyle*, which is absorbed into the system by the capillary vessels called *lacteals* (see *Chyle, Chyme*), while the non-nutritious matters pass down the intestinal canal and are carried off.

Digit (dij'it; Lat. *digitus*, a finger), in arithmetic, any one of the ten numerals, 1, 2, 3, 4, 5, 6, 7, 8, 9, 0. Digit is also a measure of a finger's breadth, equal to $\frac{3}{4}$ inch. — *Digit*, in astronomy, is the measure by which we estimate the quantity of an eclipse. The diameter of the sun or moon's disk is conceived to be divided into twelve equal parts, called *digits*; and according to the number of those parts or digits which are obscured, so many digits are said to be eclipsed.

Digitalin (dij-i-tā'lin), a vegetable alkaloid,

the active principle of the *Digitālis purpurĕa* or foxglove. It is white, difficult to crystallize, inodorous, has a bitter taste, and is a strong poison.

Digitā'lis (dij-), a genus of plants, natural order Scrophulariaceæ, containing about twenty species of tall herbs, natives of Europe and Western Asia. The purple foxglove (*D. purpurĕa*) is a common wild flower in Britain, and several species are grown in our American gardens. Various preparations from the foxglove receive this name, and are used in medicine.

Digitate (dij'), in botany, branched out into divisions resembling fingers, said of leaves or roots.

Digitigra'da, a section of the Carnivora, so called from their walking on the ends of their toes; as distinguished from the Plantigrada, which, like the bear, place the whole foot upon the ground. This tribe includes the weasel, dog, cat, &c.

Digitō'rium, a small portable dumb instrument having a short keyboard with five keys like those of a piano, used by pianoplayers for practice, to give strength and flexibility to the fingers.

Digne (dĕny), a town, France, capital of the department of Basses-Alpes, picturesquely situated on a mountain slope, 60 miles north-east of Marseilles. Pop. 6771.

Dihong. See *Brahmaputra*.

Dijon (dĕ-zhōn), a town in Eastern France, capital of the department Côte-d'Or, in a fertile plain, at the foot of a range of vine-clad slopes, formerly surrounded by ramparts, which now furnish beautiful promenades. At some distance it is surrounded by a series of forts. Some of the buildings belong to the period when Dijon was capital of the dukedom of Burgundy, the chief being the cathedral, a building of vast extent with a lofty wooden spire above 300 feet high; the churches of Notre Dame and St. Michael; the ancient palace of the dukes of Burgundy, now used as the hôtel de ville and museum; and the *palais de justice*, formerly the parliament house of Burgundy. It has important educational institutions and a valuable library. Industries: woollens, hosiery, candles, mustard, vinegar, chemicals, paper-hangings, &c., tanneries, foundries, machine factories, cotton and oil mills. The trade is considerable, particularly in the wines of Burgundy. Pop. 1891, 65,428.

Dika, a vegetable fat obtained from the seeds of a W. African tree, genus *Irvingia*, used in making fine soaps.

Dikamali, a resin exuding from Indian trees, genus *Gardenia*, a solution of which is used to dress wounds and open sores.

Dike, or **DYKE**, a word variously used in different localities to represent a ditch or trench, and also an embankment, rampart, or wall. It is specially applied to an embankment raised to oppose the incursions of the sea or of a river, the dikes of Holland being notable examples of work of this kind. These are often raised 40 feet above the high-water mark, and are wide enough at the top for a common roadway or canal, sometimes for both. The Helder Dike, one of the largest, is about 6 miles in length and involves an annual outlay of over £6000.

Dike, **DYKE**, in geology, a term applied to intrusions of igneous rock, such as basalt, greenstone, &c., which fill up veins and fissures in the stratified systems, and sometimes project on the surface like walls.

Dilapidation, in English law, is where an incumbent of a church living suffers the parsonage-house or outhouses to fall down, or be in decay for want of necessary repairs; or it is the pulling down or destroying any of the houses or buildings belonging to a spiritual living, or destroying of the woods, trees, &c., appertaining to the same. An outgoing incumbent (or his heirs) is liable for dilapidation to his successor.

Dilem'ma (from Gr. *dis*, twice, and *lēmma*, an assumption), in logic, an argument in which the same conclusion may be drawn from two contrary propositions. We append one of the most famous of the classical dilemmas. A young rhetorician said to an old Sophist: 'Instruct me in pleading and I shall pay you when I gain a cause.' The master sued for the reward, and the scholar eluded the claim by a dilemma. 'If I gain my cause I shall not pay you, because the award of the judge will be against you. If I lose it I may withhold it, as I shall not have gained a cause.' The master replied: 'If you gain you must pay me, because you promised to pay me when you gained a cause; if you lose you must pay me, because the judge will award it.' The two results which are found equally objectionable are called the 'horns' of the dilemma.

Dilettante (di-let-tān'tā), an Italian expression, signifying a lover of the arts and science, who devotes his leisure to them as a means of amusement and gratification, being thus nearly equivalent to *amateur*. In 1734 a number of gentlemen founded in London a Dilettanti Society, which pub-

lished a splendid work on Ionian Antiquities, 1769-1810; Specimens of Ancient Sculpture, Ægyptian, Etruscan, Greek and Roman, 1809, 1835; the Temples of Ægina and Bassæ, 1860; &c.

Dill, an umbelliferous plant, *Anēthum graveolens*, a native of the southern countries of Europe, the fruits, commonly but erroneously called seeds, of which are moderately warming, pungent, and aromatic, and are employed medicinally as a carminative. In appearance it resembles the fennel. Dill-seeds yield dill-water and an essential oil, when distilled with water. Dill-water is used as a remedy in flatulency and gripes of children.

Dillenia'ceæ, an order of plants, chiefly fine trees, inhabiting the E. Indies, allied to Ranunculaceæ and Magnoliaceæ.

Dillingen (dil'ing-en), an old town, Bavaria, on the Danube, 24 miles north-west of Augsburg. It was long the seat of a Jesuit university, and the castle was formerly the ordinary residence of the Bishop of Augsburg. Pop. 5452.

Dilman', a town, Persia, province of Azerbaijan, 75 miles west of Tabreez. Pop. estimated at 15,000.

Dilo'lo, a small lake in Central S. Africa, lat. 11° 30' s.; long. 22° 30' E.: regarded as the source of the Zambesi.

Dilo-oil, an oil obtained from the poon-tree of India, also called poon-seed oil. See *Poon*.

Dil'uents, in medicine, are those substances which are taken to increase the proportion of fluid in the blood. They consist of water and watery liquors.

Dilu'vium, the name formerly given by geologists to certain gravels and comparatively recent deposits, which seem to have been the result of a rush of water or *deluge*.

Dime (French, *dîme*, Lat. *decimus*, tenth), the term for the tenth part of a dollar or ten-cent piece in the United States of America, a silver coin whose English equivalent is about 5*d*.

Dimin'utive, in grammar, a word having a special affix which conveys the idea of littleness, and all other ideas connected with this, as tenderness, affection, contempt, &c. The opposite of *diminutive* is *augmentative*. In Latin, diminutives almost always ended in *lus*, *la*, or *lum*; as *Tulliola*, *meum corculum*, little Tullia, my dear or little heart; *homunculus*, a manikin. The Italian is particularly rich in diminutives and augmentatives, such compound diminutives as *fratellinucciettinetto* (a di-

minutive of *frate*, brother) being sometimes employed. Among English diminutive affixes are *kin*, as in *manikin*, a little man; *pipkin*, a little pipe: *ling*, as in *gosling*, a little goose; *darling*, that is, *dearling*, or little dear; and *et*, as in *pocket*, from *poke*, a bag or pouch; *tablet*, a little table. Diminutives are also formed, in colloquial and familiar language, by adding *y* or *ie* to the names, as *Charley*, *Mousie*, &c.

Dim'ity, a stout cotton fabric, ornamented in the loom either by raised stripes or fancy figures. It is usually employed white, as for bed and bed-room furniture.

Dimorph'ism, in crystallography, the crystallization of a body in forms belonging to two different systems, or in incompatible forms of the same system, a peculiarity exhibited by sulphur, carbon, &c.

Dimorphism, in botany, the condition when analogous organs of the same species appear under two very dissimilar forms. Thus the common primrose occurs in two forms, one having long stamens and a short pistil, the other a long pistil and short stamens.

Dinajpur', a town, Hindustan, Bengal, capital of a district of same name, 205 miles north of Calcutta; pop. 13,042. The district covers an area of about 4118 square miles; pop. 1,514,346.

Dinan (dē-nān), a town, France, department of Côtes-du-Nord (Brittany), on the Rance, 14 miles south of St. Malo. It stands on a steep hill nearly 200 feet above the river, is surrounded by high old walls pierced with four gates, and is a picturesque and interesting old place. Pop. 7860.

Dinant (dē-nān), a town, Belgium, in the province and 14 miles s. of Namur; picturesquely and strongly situated on the Meuse, a place of antique appearance. The town-house was once the palace of the Princes of Liège. Pop. 6773.

Dina'pur, a town, Hindustan, Patna district, Bengal, on the right bank of the Ganges, about 12 miles north-west of Patna, cantonment and military headquarters of the district, with extensive barracks. The environs are studded with handsome bungalows. Pop., with cantonment, 37,893.

Dinar (L. *denarius*), formerly an Arab gold coin, also a Persian coin; at present the chief Servian coin, value one franc.

Di'nas Bricks, an infusible kind of brick made of a peculiar rock, containing 98 per cent of silica, with a little alumina, which occurs at Dinas, in the vale of Neath, in

Glamorganshire, S. Wales. The rock is crushed, moistened with water, and moulded by a machine.

Dindigal, a town of India, Madras Presidency, Madura district, with a fort on a rocky height. Pop. 14,182.

Din'dorf, WILHELM, German classical scholar, born 1802, lived most of his life at Leipzig, and died 1883. His chief publications were editions of the Greek dramatists and works elucidative of them and other Greek writers.

Dingo, the native wild dog of Australia (*Canis Dingo*), of a wolf-like appearance and extremely fierce. The ears are short and erect, the tail rather bushy, and the hair of a reddish-dun colour. It is very destructive to the flocks, killing more than it eats. Its remains have been found fossil, but the fact of its having been the only placental mammal in this continent renders its indigenous character doubtful.

Ding'wall, a royal and parliamentary burgh and seaport of Scotland, county town of Ross and Cromarty, in Ross-shire, at the head of Cromarty Firth. The town, erected into a royal burgh in 1227, unites with Wick and other places in returning a member to parliament. Pop. 1921.

Dinitronaphthol. See *Naphthyl*.

Dino'ceras (Gr. *deinos*, terrible, *keras*, a horn), a fossil mammal found in the Eocene strata of N. America, in some respects akin to the elephant and of equal size, but without a proboscis. Its bones were very massive; it had two long tusks in the upper jaw, three pairs of horns, and the smallest brain, proportionally, of any known mammal.

Dinor'nis (Gr. *deinos*, terrible, *ornis*, a bird), an extinct genus of large wingless birds—classed among the Struthionidæ or ostrich tribe—the bones of five species of which have been found in New Zealand. The largest must have stood at least 14 feet in height, several of its bones being at least twice the size of those of the ostrich. The body seems to have been even more bulky in proportion, the tarsus being shorter and stouter in order to sustain its weight. They do not appear to have become extinct until the 17th or 18th century, and are spoken of as *moas* by the natives, who buried the eggs with their dead as provision for their journey to the other world.

Dinosau'ria (Gr. *deinos*, terrible, and *sauros*, a lizard), a group of colossal lizards, resembling the pachydermatous mammals in general appearance, but in reality inter-

mediate between the struthious birds and lizards. The majority, as the Megalosaurus, which attained to 40 feet in length, were carnivorous; the Iguanodon, however, was



Dinornis (pelvic and leg bones and outline of body).

herbivorous. They were the land reptiles of the Jurassic, Wealden, and inferior Cretaceous continents.

Dinothe'rium (Gr. *deinos*, terrible, *thērion*, beast), a genus of extinct gigantic mammals, the remains of which occur in Tertiary formations in several parts of Europe. The largest species (*D. giganteum*) is calculated to have attained the length of 18 feet. It had a proboscis and also two tusks placed at the anterior extremity of the lower jaw, and curved downwards somewhat



Dinotherium restored.

after the manner of those in the upper jaw of the walrus. The zoological position of the Dinotherium is that of a proboscidean allied to the elephant. The skull, molar teeth, and scapular bone are the only portions yet discovered. Kaup regards it as intermediate between the mastodons and tapirs, and terrestrial; while Blainville and Pictet regard it as allied to the sea-cows,

and inhabiting the embouchure of great rivers.

Di'ocese (Greek, *diokēsis*, administration), the circuit or extent of a bishop's jurisdiction. Each English diocese is divided into archdeaconries, each archdeaconry (nominally) into rural deaneries, and each deanery into parishes. See *Bishop*.

Diocle'tian (C. VALERIUS DIOCLETIANUS, surnamed *Jovius*), a man of mean birth, a native of Dalmatia, proclaimed Emperor of Rome by the army 284 A.D. He defeated Carinus in Mœsia (286), conquered the Allemanni, and was generally beloved for the goodness of his disposition, but was compelled by the dangers threatening Rome to share the government with M. Aurelius Valerius Maximian. In 292 C. Galerius and Constantius Chlorus were also raised to a share in the empire, which was thus divided into four parts, of which Diocletian administered Thrace, Egypt, Syria, and Asia. As the result of his reconstitution of the empire there followed a period of brilliant successes in which the barbarians were driven back from all the frontiers, and Roman power restored from Britain to Egypt. In 305, in conjunction with Maximian, he resigned the imperial dignity at Nicomedia, and retired to Salona in Dalmatia, where he cultivated his garden in tranquillity until his death in 313. In the latter part of his reign he was induced to sanction a persecution of the Christians.

Dioda'ti, GIOVANNI, Italian Protestant divine, born at Lucca, about 1576, of a noble Catholic family. He was for some time professor, first of Hebrew, then of theology, at Geneva, and in 1619 represented the Genevan clergy at the Synod of Dort, and aided in drawing up the Belgic confession of faith. He is most celebrated for a translation of the Bible into Italian, which is superior to his translation of it into French. He died at Geneva in 1649.

Di'odon. See *Globe-fish*.

Diodo'rus OF ARGYRIUM, in Sicily, and therefore called *Siculus*; a Greek historian in the time of Julius Cæsar and Augustus. His universal history, in the composition of which he travelled through a great part of Europe and Asia, occupied him thirty years, and consisted of 40 books, but only books 1-5 and 11-20, with certain fragments, are now extant.

Diœ'cious (Gr. *di*, double, *oikos*, a house), in botany, a term applied to plants which have flowers with stamens on one individual

and those with pistils on another: as opposed to *monœcious*. The willow, the yew, the poplar, &c., are diœcious.

Diogenes (di-øj'e-nēz) OF APOLLONIA (Crete), known also as the *Physicist*, a Greek philosopher of the 5th century B.C., who belonged to the Ionian school, and considered air as the element of all things.

Diogenes OF SINOPE (on the Black Sea), the most famous of the Cynic philosophers, born about 412 B.C. Having been banished from his native place with his father, who had been accused of coining false money, he went to Athens, and thrust himself upon Antisthenes as a disciple. Like Antisthenes he despised all philosophical speculations, and opposed the corrupt morals of his time; but while the stern austerity of Antisthenes was repulsive, Diogenes exposed the follies of his contemporaries with wit and good humour. As an exemplar of Cynic virtue he satisfied his appetite with the coarsest food, practised the most rigid temperance, walked through the streets of Athens barefoot, without any coat, with a long beard, a stick in his hand, and a wallet on his shoulders, and by night, according to the popular story, slept in a tub (or large earthenware vessel). On a voyage to the island of Ægina he fell into the hands of pirates, who sold him as a slave to the Corinthian Xenocrates in Crete. The latter emancipated him, and intrusted him with the education of his children. He attended to the duties of his new employment with the greatest care, commonly living in summer at Corinth and in winter at Athens. He died 323 B.C., at a great age. Of the many stories related of him the majority are probably fictions; many indeed are chronologically impossible. His enemies accused him of various scandalous offences, but there is no ground for supposing him guilty of any worse fault than that of elevating impertinence to the rank of a fine art.

Diogenes Laërtius, author of a sort of history of philosophy in Greek, appears to have been born at Laerte, in Cilicia, and to have lived towards the close of the second century after Christ; but no certain information exists either as to his life, studies, or age. The work is divided into ten books, and bears in MSS. the title, *On the Lives, Doctrines, and Apothegms of those who have distinguished themselves in Philosophy*. It is full of absurd and improbable anecdotes, but contains valuable information regarding the private life of the Greeks, and many frag-

ments of works now lost. It was the foundation of the earlier modern histories of philosophy.

Diomedea'a, a genus of birds, including the various species of albatross (which see).

Diomedea Islands, a group of three small islands in Behring's Strait, and midway between Asia and America.

Diomedes (dī-o-mē'dēz), in Greek mythology, (1) A king of the Bistōnes, who fed his horses on human flesh, and used to throw all strangers who entered his territories to those animals to be devoured. He was killed by Hercules, who carried off the horses. (2) One of the heroes at the siege of Troy, the son of Tydeus and Deipyle, and king of Argos, one of the suitors of Helen. After she was carried off Diomedes engaged in the expedition against Troy, in which his courage and the protection of Pallas rendered him one of the most distinguished heroes. He wounded Aphrodite and Ares, and thrice assailed Apollo; and by carrying off the horses of Rhœsus from the enemies' tents, and aiding Ulysses in the removal of Philoctetes from Lenmos, he fulfilled two of the conditions on which alone Troy could be conquered. Finally he was one of the heroes concealed in the wooden horse by whom the capture of Troy was at length accomplished. Different accounts were given of his after-life. He is often called *Diomede*.

Dion OF SYRACUSE, in Greek history, a connection by marriage of the elder and the younger Dionysius, tyrants of Syracuse, over whom he long exercised great influence. He attempted to reform the younger Dionysius (see the art.), but his enemies succeeded in effecting his banishment. He afterwards returned and made himself ruler of the city, but became unpopular, and in 353 B.C. one of his followers, Callipus of Athens, caused him to be assassinated.

Dionæ'a, a genus of plants, nat. order Droseraceæ. Only one species is known, *D. muscipula* (Venus's fly-trap), a native of the sandy savannas of Carolina and Florida. It has a rosette of root leaves, from which rise a naked scape bearing a corymb of largish white flowers. The leaves have a dilated petiole and a slightly-stalked 2-lobed lamina, with three short stiff bristles on each lobe. The bristles are remarkably irritable, and when touched by a fly or other insect the lobes of the leaf suddenly close on and capture the insect. It is said to digest the food thus captured by means of a fluid which

dissolves it exactly like ordinary gastric juice.

Dion Cassius, or DIO CASSIUS, a Greek historian, born about 155 A.D. at Nicæa, in Bithynia. After accompanying his father to Cilicia, of which he held the administration, he came to Rome about 180, and obtained the rank of a Roman senator. On the accession of Pertinax Dion was appointed prætor, and in the reign of Caracalla he was one of the senators whom it had become customary to select to accompany the emperor in his expeditions, of which he complains bitterly. In 219 he was raised to the consulship, and about 224 became proconsul of Africa. In 229 he was again appointed consul; but feeling his life precarious under Alexander Severus, he obtained permission to retire to his native town of Nicæa. The period of his death is unknown. The most important of his writings, though only a small part is extant, is a History of Rome, written in Greek and divided into eighty books, from the arrival of Æneas in Italy and the foundation of Alba and Rome to A.D. 229.

Dion Chrysostom, a Greek sophist and rhetorician and a favourite of Trajan; born A.D. 50, died about A.D. 110. Eighty of his orations (in excellent Attic) have been preserved.

Dionys'ia. See *Bacchanalia*.

Dionys'ius, St., a disciple of Origen, and patriarch of Alexandria in 248 A.D. He was driven from the city in 250, and in 257 was banished to Libya, but was restored in 260. Died in 265 A.D.

Dionysius OF HALICARNASSUS, in Caria, a Greek critic and teacher of eloquence, born about 70 B.C. He went to Rome about 30 B.C., where he wrote his Roman Antiquities, in twenty books, in which he relates (in Greek) the early history of Rome and its government up to the times of the first Punic war. We have the first nine books of this work entire, the tenth and eleventh nearly so, and some fragments of the others. His rhetorical writings are of greater value, especially his essays on the Greek orators. He died about 6 B.C.

Dionysius THE AREOPAGITE, that is, one of the judges of the Areopagus, at Athens, a convert to Christianity by the Apostle Paul about the middle of the first century, and the first bishop at Athens, where he suffered martyrdom. Certain writings formerly ascribed to him consist of obscurely-written treatises on mystical subjects. Scotus Erigena translated them into Latin. In

France, where a certain Dionysius (see *Denis, St.*) established the first Christian community at Paris in the 3d century, they were readily received, this Dionysius being without further inquiry taken for the Areopagite, because the origin of the Gallican Church could thus be carried back to the 1st century; and France gained a patron who was a martyr and the immediate disciple of an apostle.

Dionysius THE ELDER, in Greek history, tyrant or absolute ruler of Syracuse, born about 430 B.C. of obscure parentage. He obtained the rank of general, and afterwards of commander-in-chief; and gaining the support of the army, he seized the supreme power in Syracuse, though only twenty-five years of age. He extended his rule over other cities in Sicily; and after some successes and reverses in the struggle with the Carthaginians he gained a complete victory over them under the walls of Syracuse. In his expeditions into Lower Italy he reduced the city of Rhegium by famine (387). After another short war with Carthage he lived some time in peace, occupied with writing poems, tragedies, &c., with which he contended for the Olympian prize. In 368 he commenced a new war against the Carthaginians, but failed to drive them entirely out of Sicily. He is said to have died from a potion administered at the instigation of his son Dionysius the Younger (367 B.C.).

Dionysius THE LITTLE (so called on account of his short stature), a Scythian monk who was abbot of a monastery at Rome in the beginning of the 6th century, and died about the year 530, according to others about 545, celebrated as the author of the computation of time from the Christian era. This mode of computation, however, was not publicly used until the 8th century.

Dionysius, THE YOUNGER, a tyrant of Syracuse, who in 367 B.C. succeeded his father, Dionysius the Elder. For the purpose of recalling him from the excesses to which he was addicted Dion persuaded him to invite Plato to his court, but the influence of the philosopher effected no permanent change. Becoming suspicious of Dion, the tyrant banished him and confiscated his property, but in 357 B.C. Dion made himself master of Syracuse. Dionysius fled to Locri, but after the murder of Dion recovered his power in Syracuse. His misfortunes, however, had rendered him more cruel, and Timoleon, who came to Syracuse with aid from Corinth against the Cartha-

ginians, deposed him in 344 B.C. He was carried to Corinth, where he is said to have gained a living by giving lessons in grammar, or as one of the attendants on the rites of Cybele.

Diony'sus, the original Greek name of the god of wine, the name Bacchus, by which he was also called both by the Greeks and the Romans, being at first a mere epithet or surname. See *Bacchus*.

Diophan'tus OF ALEXANDRIA, the first Greek writer on algebra, flourished, according to some authorities, about the middle of the 4th century after Christ. He left behind him thirteen books of Arithmetical Questions, of which only six are extant; and a work on Polygon Numbers.

Diop'side, a rare mineral, a variety or subspecies of augite, occurring in prismatic crystals of a vitreous lustre, and of a pale-green, or a greenish or yellowish white.

Diop'sis, a genus of dipterous insects, or two-winged flies, the members of which are remarkable for the immense prolongation of the sides of the head, the head appearing as if it were furnished with two long horns, each having a knot at its apex.

Di'optase, emerald copper ore, silicate of copper, a translucent mineral, occurring crystallized in six-sided prisms.

Diop'trics, that part of optics which treats of the refraction of light passing through different mediums, as through air, water or glass, and especially through lenses. These phenomena, however, are now more commonly treated under the head of *refraction*. See *Refraction*.

Diora'ma, a mode of painting and of scenic exhibition invented by Messrs. Daguerre and Bouton, and first exhibited in 1823. It secures a higher degree of illusion than the ordinary panorama, by a mode of uniting transparent painting to the usual opaque method, and causing the light to fall upon the picture both from *before and behind*. At the same time, by means of coloured transparent blinds, suspended both above and behind the picture, the rays of light can be intercepted and made to fall at pleasure in graduated tints upon every part of the picture in succession.

Di'orite, a tough trap-rock, sometimes of a whitish colour speckled with black or greenish-black, sometimes very dark in colour, consisting of hornblende and felspar.

Dioscoreaceæ, a nat. order of endogenous plants, with alternate reticulate-veined leaves, tuberous root-stocks and twining

stems. The flowers are small and unisexual. There are six genera, with about 100 species. The typical genus is *Dioscorea*, which includes the yam. Black bryony is the only British representative. See *Yam*.

Dioscorides, PEDANIUS, born in Cilicia in the first century of the Christian era, a Greek physician, author of a celebrated work on *materia medica*, in five books, particularly valuable in regard to botany.

Dioscūri. See *Castor and Pollux*.

Diosma, a genus of rutaceous plants inhabiting Southern Africa, allied to *Barosma* (which see). They have alternate or opposite simple leaves, strongly marked with dots of transparent oil, and diffusing a powerful odour when bruised. Some species are cultivated for their white or pinkish flowers.

Diospyros, a large genus of trees or shrubs, natives of the warmer regions of the world, nat. order Ebenaceæ. The trees of this genus supply ebony wood. That from Ceylon is the wood of *D. Ebenum*; from India, of *D. melanoxylon* and *D. Ebenaster*; and that from Mauritius *D. reticulata*. The *D. Lotos* is the Indian date-plum. It is by some supposed to have been the lotus-tree of the ancients, whose fruit was said to produce oblivion.

Dip of the horizon, an allowance made in all astronomical observations of altitude for the height of the eye above the level of the sea.

Dip, in geology, the inclination or angle at which strata slope or *dip* downwards into the earth. The degree of inclination or amount of the dip, which is easily measured by a special instrument, is determined by the angle which a line drawn perpendicular to the direction of the stratum makes with the horizon. The line in which such strata cut the surface is called the *strike*, and is always at right angles to the dip.

Diphtheria, a malignant disease characterized by the formation of a thick leathery false membrane in the throat, and allied to croup, which, indeed, is often considered a form of it, the disease being called diphtheria when it attacks principally the tonsils and parts in their neighbourhood, and croup when it principally attacks the larynx. (See *Croup*.) It has only in recent times attracted public attention by its frequency and peculiar symptoms. It is a most fatal disease, resulting from the introduction into the body of a specific poison, is contagious, often epidemic, and in some places endemic. It is always accompanied by a very low state of

the system, indicating the necessity of giving stimulating nourishment very freely. The membrane may spread more or less, going down into the windpipe or up the nose, and death may be caused by suffocation and exhaustion, the violence of the poison sometimes causing it even without the formation of the membrane. The most essential thing in its treatment is to keep up the strength by food and stimulants, and apply antiseptic agents to the exudation on the throat. See *Anti-Toxin*.

Diphthong, a coalition or union of two vowels pronounced in one syllable. In uttering a proper diphthong both vowels are pronounced; the sound is not simple, but the two sounds are so blended as to be considered as forming one syllable, as in *void*, *bough*. The term improper diphthong is applied to the union in one syllable of two or more vowels, of which only one is sounded, as in *bean*.

Di'phyodont, a term applied to those animals which develop two sets of teeth, a deciduous or milk set, and a permanent set—as distinct from the monophyodonts, which develop only one set. The majority of mammals are diphyodont, though the number of teeth replaced may vary: thus in man twenty teeth of the adult are preceded by a milk set; in the hare, the anterior incisors are not so preceded, but the posterior smaller incisors replace an earlier pair.

Diplacan'thus, a genus of ganoid fishes, found only in the Old Red Sandstone. They have small scales, a heterocercal tail, and two dorsal fins with a strong spine in front.

Diplei'doscope, an instrument for indicating the passage of the sun or a star over the meridian, by the coincidence of two images of the object, the one formed by single and the other by double reflection. It consists of an equilateral hollow prism, two of whose sides are silvered on the inside so as to be mirrors, while the third is formed of glass. The prism is adjusted so that one of the silvered sides shall be exactly in the plane of the meridian, and the transparent side towards the object.

Diplo'ma (Gr. *diplōma*, from *diploō*, to double or fold), literally a document folded but once, and therefore divided into two parts. It is used to signify a document signed and sealed, in which certain rights, privileges, dignities, &c., are conferred, especially a university degree.

Diplo'macy, the science or art of conducting negotiations, arranging treaties, &c., be-

tween nations; the branch of knowledge which deals with the relations of independent states to one another; the agency or management of envoys accredited to a foreign court; the forms of international negotiations. The Cardinal de Richelieu is generally considered as the founder of that regular and uninterrupted intercourse between governments which exists at present between almost all the Christian powers; though the instructions given by Machiavelli to one of his friends, who was sent by the Florentine Republic to Charles V. (Charles I. of Spain) show that Richelieu was not the first to conceive the advantages that might be derived from the correspondence of an intelligent agent accredited at the seat of a foreign government. Diplomatic agents are of several degrees: 1, ambassadors; 2, envoys extraordinary and ministers plenipotentiary; 3, ministers resident; 4, *chargés d'affaires*; 5, secretaries of legation and *attachés*. Their rank was regulated in Europe, in the above order, by the congress assembled at Vienna in 1814. Amongst the European powers it is agreed that of ministers of the same rank he who arrives first shall have the precedence over his colleagues.

Diplomat'ics, originally the science of deciphering ancient MSS. It laid down certain principles for the systematic examination of public documents, and taught the forms and styles adopted in them, the titles and rank of public officers subscribing them, &c. Among the earliest exponents of diplomatics were Papebroeck, an Antwerp Jesuit (1675), and Mabillon (*De re Diplomatica*, 1681).

Diplop'terus, a genus of fossil ganoid fishes, of four species, belonging to the Old Red Sandstone.

Diplozo'on, a parasitic trematode worm which infests the gills of the bream, and which appears to be formed of two distinct bodies united in the middle, and resembling an X or St. Andrew's cross, two sexually mature individuals being thus united.

Dip'noi (Gr. *di, dis*, double, and *pnoē*, breath), an order of fishes, including only the singular mud-fishes (*Lepidosiren*), important as exhibiting the transition between fishes and the amphibia. Formerly *Lepidosiren* was reckoned the lowest of the amphibia, now it constitutes the highest order of fishes. The body is fish-like in shape, covered with small horny scales of a cycloid character; the pectoral and ventral

fins are represented by two pairs of long filiform organs; the heart has two auricles and one ventricle, and the respiratory organs are twofold, consisting of ordinary gills opening externally, and of true lungs—formed by the modified swimming-bladder—communicating with the œsophagus by means of an air-duct or trachea, whence the name. They are also called *Protopteri*. The combination of respiratory organs is similar to that which is presented by the tailed amphibia with persistent gills (perennibranchiate), as the axolotl. This interesting group is allied to the ganoids through the *Ceratodus* of Queensland. The *L. paradoxa* is found in the Amazon; *L. annectens* in the Gambia.

Dippel, JOHANN CONRAD, German theologian and alchemist, born 1672. He studied theology, defended the orthodox party against the Pietists, led a turbulent life at Strasburg, and then joined the Pietists until an unfortunate tractate placed him in disfavour with both parties. He then turned his attention to alchemy, and during a residence at Berlin produced the oil called after him (see next art.), from which indirectly followed the discovery of Prussian or Berlin blue. After various adventures and wanderings in Sweden, Denmark, and Germany he died in 1734.

Dippel's Oil, the rectified form of the black fetid oil, containing ammoniac carbonate, which can be obtained by the destructive distillation of animal matter, such as stag's-horn, ivory, or blood. The cruder form was used in medicine, despite its appearance and odour, until Dippel refined it. His oil was formerly prescribed as an antispasmodic and diaphoretic, and as a hypnotic.

Dipper, a bird of the genus *Cinclus*, allied to the thrushes. The common dipper, water-ouzel, or water-crow (*Cinclus aquaticus*), is a familiar European bird; it is about 7 inches in length, with a very short tail, small rounded wings, and large powerful feet; the bill is of moderate length, straight, and slender. The male has the upper part of the body dark brown, the throat and breast white, belly rusty. The dipper frequents streams, and feeds largely on water-insects and larvæ. It can dive and walk under water, effecting its progress by grasping the stones with its feet. The song is sweet and lively. Other species are found in Asia and America.

Dipping-needle, or INCLINATION COMPASS, an instrument for showing the direction of one of the components of the earth's

magnetism. In essentials the instrument consists of a light magnetized steel bar supported on a horizontal axis which passes, as nearly as possible, through the centre of



Dipper (*Cinclus aquaticus*).

inertia of the bar. When a needle thus mounted is placed anywhere not in the magnetic equator, it dips or points downward; and if the vertical plane, in which it moves, coincides with the magnetic meridian the position of the needle shows at once the direction of the magnetic force. The intersection of two or more directions found by making the experiment at different places, indicates the place of the magnetic pole.

Dipro'todon, a gigantic fossil marsupial of Australia, allied to the kangaroos.

Dip'sacus. See *Teasel*.

Dipsas, a genus of Asiatic and tropical American non-venomous serpents of the family Colubridæ, of very elongated form. With the ancients it was a serpent whose bite was said to produce a mortal thirst.

Dipsoma'nia (Greek, *dipsa*, thirst, and *mania*, madness), a term recently introduced to denote an insane craving for intoxicating liquors, when occurring in a confirmed or habitual form. It is often of hereditary origin, but may result from sunstroke, from some injury to the brain, or from disease. The only remedy appears to be seclusion, with enforced abstinence and healthy occupation. Homes for this purpose have been established in Britain under the Habitual Drunkards Act of 1879. A number of corresponding institutions have long existed in the United States.

Dip'tera, an order of two-winged insects, of which the common house-fly and blue-bottle are familiar examples. They are characterized by a body with slight coriaceous coverings, a trunk open beneath, and containing a sucker composed of two, four,

or six lancet-shaped elongated scales, two palpi, antennæ almost always composed of three joints, large eyes, an abdomen of four to seven distinct segments, tarsi with five joints, and two short clubbed appendages called *haltères* or balancers, which seem to be the rudiments of the posterior pair in four-winged insects, and are kept in continual motion. All undergo complete metamorphosis, and all are oviparous except the Sarcophaga, which issue from their mother in shape of larvæ; and the Pupipara, which first make their appearance as nymphs. The greater number live on the sap of flowers, but some feed on blood, others fasten on other animals to lick up their perspiration, their sores, or various secretions.

Dipteraceæ, **DIPTEROCARPEÆ**, an important order of Asiatic exogenous polypetalous trees, allied to the mallows (Malvaceæ). The different species produce a number of resinous, oily, and other substances; one, a sort of camphor; another, a fragrant resin used in temples; and others, varnishes; while some of the commonest produce pitches, and sal, valuable timber.

Diptych (dip'tik; Greek) originally signifies the same as *diploma*, something folded; the double tablets of metal, ivory, &c., used by the Greeks and Romans. Diptychs became important in the Christian church, in them being written the names of popes, and other distinguished persons, who had deserved well of the church, to be mentioned in the church prayers. Diptychs also often contained pictures of biblical scenes, &c.

Di'pus. See *Jerboa*.

Dipyre (dī'pīr), a mineral consisting chiefly of silicate of alumina, with small proportions of the silicates of soda and lime. Its name indicates the double effect of fire upon it (Gr. *di*, double, *pyr*, fire) in producing first phosphorescence, and then fusion.

Diræ, or **EUMENIDES**. See *Furies*.

Directors, persons elected to meet together at short fixed intervals and consult about the affairs of corporations or joint-stock companies, and to advise and assist the manager. These are termed *Ordinary Directors*, as in many companies there is a body called *Extraordinary Directors*, who have little or no business functions, and are chosen as a rule on account of their social position imparting a degree of distinction to the concern. Directors are appointed by a general meeting of the shareholders in the undertaking, and a certain number of them,

usually a third, retire every year. Ordinary directors are granted a certain remuneration for their services. The duties and responsibilities of directors are defined by the constitution of the company, or by the various acts of legislature affecting joint-stock and other companies.

Director, the name given to a body of five officers to whom the executive authority in France was committed by the constitution of the year III. (1795). The two legislative bodies, called the *councils*, elected the members of the directory: one member was obliged to retire yearly, and his place was supplied by election. This body was invested with the authority, which, by the constitution of 1791, had been granted to the king. By the revolution of the 18th Brumaire the directory and the constitution of the year III. were abolished. It was succeeded by the consulate.

Directrix, in math. a line perpendicular to the axis of a conic section, and so placed that the distance from it of any point in the curve is to the distance of the same point from the focus in a constant ratio; also, the name given to any line, whether straight or not, that is required for the description of a curve. The directrix of a parabola is a line perpendicular to the axis produced, and whose distance from the vertex is equal to the distance of the vertex from the focus. Thus *AB* is the directrix of the parabola *VED*, of which *F* is the focus.

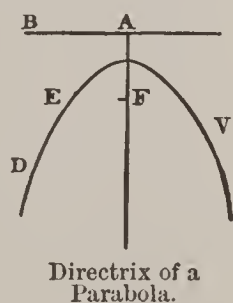

Dirk, a kind of dagger formerly used as a weapon of offence by the Highlanders of Scotland. Dirks are worn by midshipmen and cadets of the royal navy, and still form part of the full Highland costume.

Dirk-Hartog Island, on the west coast of Australia, 45 miles long north to south, and 10 miles broad.

Dirt-beds, in geology, layers of ancient soil, such as those in the oolitic strata of the Isle of Purbeck (Dorset), which contain the stumps of trees that once grew in them.

Disability, in law, incapacity to do any legal act. It is either *absolute*, which wholly disables the person; such as outlawry or excommunication—or *partial*, such as infancy, coverture, insanity, or drunkenness.

Disbanding, the breaking up of a regiment, or other body of military, and releasing them from service, when they are no

longer required, or it may be on account of insubordination.

Disbarring, expelling a barrister from the bar, a prerogative which, in England, is possessed by the benchers of each of the four Inns of Court. The party disbarred may lodge an appeal with the judges in their capacity of visitors.

Disc, DISK, the central part of a radiate compound flower surrounded by the ray.

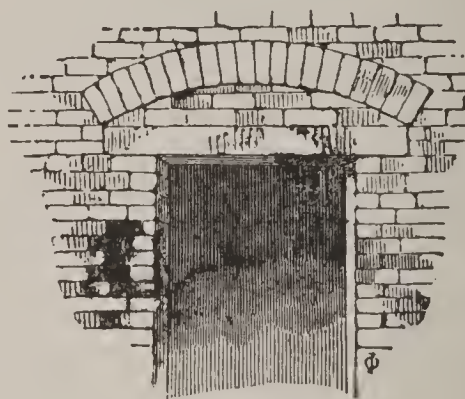

Discharging Arch.

Also a part, sometimes cup-shaped, at the base of the stamens, consisting in some cases of rudimentary stamens, in others of the modified receptacle.—In astronomy the term is applied to the face or circular figure exhibited by the sun, moon, or a planet in the sky.

Discharge. See *Calico-printing*.

Discharging Arch, an arch formed in the substance of a wall to relieve the part which is below it from the superincumbent weight. Such arches are commonly used over lintels and flat-headed openings.

Discipline, BOOKS OF, two books connected with the Church of Scotland. The First Book of Discipline was drawn up by John Knox and four other ministers, and laid before the General Assembly in 1560. Though not formally ratified by the privy-council, it was secretly subscribed by the greater part of the nobility and barons who were members of the council. Another similar document, the Second Book of Discipline, was prepared and sanctioned by the General Assembly of 1578, and has from that time been recognized as the authorized standard of the Church of Scotland in respect of government and discipline.

Disclaim'er, in its stricter legal sense, a plea containing renunciation or a denial of some claim alleged to have been made by the party pleading.

Discoph'ora, a sub-class of the Hydrozoa, comprising most of the organisms known as sea-jellies, jelly-fishes, sea-nettles, &c.

Dis'cord, in music, a dissonant or inharmonic combination of sounds, so called in opposition to the *concord*. See *Dissonance*.

Dis'count, the charge made by a banker for interest of money advanced by him on a bill or other document not presently due. In advancing money on such a security the banker deducts the charge for interest on his advance from the total amount represented on the security, pays the difference, which is called the *proceeds* of the bill, to the person parting with it, and collects the full amount to reimburse himself for outlay and interest at maturity. Popularly the term *discount* is applied to any deduction from the full amount of an account made by the party to whom it is paid, especially on prompt or early payment. When a bill which has been *discounted* is paid by the acceptor before it is due, the discount allowed for prepayment is called *rebate*.

Discov'ery, in law, the act of revealing or making known any matter by a defendant in his answer to a bill in chancery. The word is also used in reference to the disclosure by a bankrupt of his property for the benefit of his creditors.

Dis'crase, an ore of silver, consisting of antimony and silver. It occurs in hexagonal prisms, massive, disseminated or granular.

Discus, **DISC**, or **DISK**, among the Greeks and Romans a quoit of stone or metal, convex on both its sides, sometimes perforated in the middle. The players aimed at no mark, but simply tried to throw the quoit to the greatest possible distance. It was sometimes furnished with a thong of leather to assist in the throwing.

Disease, any morbid state of the body, or of any organ or part of the body. Diseases are described as local or constitutional, idiopathic, symptomatic, epidemic, endemic, contagious, acute, chronic, &c. As to their classification, see *Nosology*. The influence of the parents on the organization of the child is so great that not only peculiarities of external form, but the peculiar constitution, the greater or less activity and development of the organs, are found to pass from parent to child. As it is in the particular state of the several organs and functions that a very great part of diseases have their foundation, the liability to certain diseases is inevitably inherited with the organic structure, and the son is not unfrequently attacked by various complaints at the same period of life in which his father was.

These diseases are called *hereditary*; but it is only the predisposition to them that is, properly speaking, inherited. Hence the actual development of hereditary diseases requires certain co-operating circumstances. Constitutional diseases are very often not hereditary, but depend on circumstances which affect the fœtus during pregnancy. Among the diseases which are most frequently hereditary are scrofula, bleeding (especially at the lungs) and hemorrhoids, consumption, gout, the gravel and stone, cancer, disorders of the mind and spirits, hysterical and hypochondriac affections, apoplexy, epilepsy, and organic diseases of particular parts, especially of the heart. Inherited diseases are much more difficult to cure than those which originate in accidental external causes, and special care should therefore be taken to adopt an environment and mode of life calculated to counteract the inherited predisposition. As to the origin of certain diseases see *Germ Theory*.

Diseases of Plants may be divided into two main classes: those produced by temperature, excess or deficiency of moisture and light, impure air, the composition of the soil, and other mechanical or chemical agencies; and those produced by other organized beings, whether belonging to the animal or vegetable world. Too high a temperature will produce an excitement inconsistent with healthy growth, while a low temperature destroys the connection between the cells, and is one of the chief causes of canker. In the absence of light the chemical changes necessary to the complete development of the chlorophyll will not take place, and the plant is in consequence blanched. Tender tissues, however, frequently require protection from a too free admission of light. In tropical forests, unhealthy to man, certain vegetables find a congenial atmosphere, but in most cases pure air is indispensable, as shown by the difficulty of cultivating plants in the heart of towns. Few things are more prejudicial to plant life than excess of moisture, partly from its immediate action on the tender tissues of the roots, and partly from decomposition, but, more than all, from the low state of temperature which is kept up at the very point where a certain degree of heat is essential. Diseases springing from the actions of other organisms may be classed as direct injuries, alterations of tissues from the presence of larvæ of insects, exhaustion from parasitic insects or plants, especially fungi.

Dishonour of a Bill, the refusal or neglect to accept or pay when due a bill of exchange, or promissory note, or draft on a banker. It is absolutely necessary that the holder of a dishonoured bill should give immediate notice of the non-payment to the drawer or indorsers.

Disinfectant, any substance that destroys the germs of contagious and infectious diseases. The most important for practical purposes are chlorine, carbolic acid, sulphurous acid, Condy's green and red fluids, containing respectively manganate and permanganate of potash, and Burnett's fluid, containing chloride of zinc. Carbolic acid is one of the most effective, needing, however, some little care in the handling, as it sometimes causes severe burns. It does not in its common form mix with water, but floats on the surface undiluted. For application to the skin Condy's fluid is one of the readiest preparations. In cases of infectious or contagious disease, disinfectants such as chlorinated lime or carbolic acid should at once be placed about the house, especially in the sick room and in the passages and landing outside it. A large sheet also should be nailed so as to hang across the door, and this should be kept constantly wet with carbolic acid. All excretions should be instantly disinfected and also the closet which receives them. In a country place it is best to bury them in a considerable depth of earth. Every article of clothing and furniture should be carefully treated, as the germs may lurk in them and break out after a lapse of months or years.

Disintegrator, a machine for pulverizing and sometimes for mixing various materials, such as rock, asphalt, ore, artificial manures, sugars, corn, the ingredients of mortar, &c.

Disk. See *Disc*.

Dislocation, a surgical term applied to cases in which the articulating surfaces of the bones have been forced out of their proper places. The particular dislocation takes its name either from the joint itself or its furthest bone, and is called *compound* when accompanied with an external wound. The most common dislocations are those of the hip, shoulder, elbow, knee, and ankle, and the chief obstacle to their reduction is the spasmodic and violent contraction of the muscles consequent upon them, the application of considerable force being often necessary to set the joint. Chloroform is of great use, not only in preventing pain but in relaxing the muscles. The most

dangerous dislocations are those of the bones of the spine.—In geology it signifies the displacement of parts of rocks or portions of strata from the situations they originally occupied.

Dismal Swamp, a large tract of marshy land in America, beginning a little south of Norfolk, in Virginia, and extending into North Carolina, containing 150,000 acres: 30 miles long, from north to south, and 10 broad. This tract was entirely covered with trees, with almost impervious brushwood between them, but it has now in part been cleared and drained. In the midst of the swamp is a lake, called *Drummond's Pond*, 7 miles in length. A navigable canal through the swamp connects Chesapeake Bay and Albemarle Sound.

Dismas, St., the name of the penitent thief according to mediæval legends.

Dispart, the difference between the semi-diameter of the base ring at the breech of a gun and that of the ring at the swell of the muzzle.

Dispensary, a charitable institution for the free supply of medicine to the poor. Each institution has one or more physicians, surgeons, and apothecaries, who attend at stated times in order to prescribe for the sick, and, if necessary, to visit them at their own habitations. A note from a subscriber or governor is usually required by would-be patients. Provident dispensaries are similar institutions in which a small fee is exacted.

Dispensation is the act by which an exception is made to the rigour of the law in favour of some person. The pope may release from all oaths or vows, and may sanction a marriage within the prohibited degrees of the Mosaic law, or exempt from obedience to the disciplinary enactments of the canon law. In England the monarch claimed, in former times, a similar dispensing power in civil law, but the prerogative was so much abused by James II. that it was abolished by the Bill of Rights. The power of commuting sentences in capital cases is the only form in which the dispensing power of the crown still exists. In ecclesiastical matters a bishop may grant a dispensation allowing a clergyman to hold more than one benefice, or to absent himself from his parish.

Dispensatory, the same as *Pharmacopœia* (which see).

Dispersion, an optical term applied to the angular separation experienced by the com-

ponent rays of a pencil of light on emerging from a refracting medium, whose surfaces are not parallel to each other, *e.g.* the common prism. The length of the spectrum and the relative space occupied by the coloured rays vary greatly according to the refracting medium, the spectrum from a prism of oil of cassia being two or three times longer than one formed by a glass prism.

Disposition, in Scotch law, is, in its general acceptation, a deed by which a person provides for the general disposal of his property heritable and movable, after his death, equivalent to a will or testament; also a conveyance of property.

Disraeli, BENJAMIN. See *Beaconsfield*.

D'Israeli (diz-rā'e-li), ISAAC, man of letters, and father of the well-known statesman, was born at Enfield, Middlesex, in 1766. His father, Benjamin D'Israeli, a descendant of a family of Spanish Jews which had settled at Venice in the fifteenth century to escape the Inquisition, came over to England in 1748 and made a large fortune. Isaac D'Israeli, however, showed a strong repugnance to commerce, and was finally permitted to follow his literary bent. An anonymous reply to Peter Pindar, entitled *On the Abuse of Satire*, was followed in 1791-1793 by the appearance of his *Curiosities of Literature*, the success of which determined much of his afterwork. His *Essay on the Literary Character* was published in 1795, and some time afterwards a volume of romantic tales, *The Loves of Mejnoun and Leila*. Between 1812 and 1822 appeared his *Calamities of Authors, Quarrels of Authors, and Inquiry into the Literary and Political Character of James I.*; the three being afterwards published collectively under the title of *Miscellanies of Literature*. In 1828 appeared the commencement of his *Life and Reign of Charles I.*, a work completed in 1831. An affection of the eyes put an end to a projected life of Pope and a history of English Freethinkers, but in 1841 he published a selection from his MSS. under the title of *Amenities of Literature*. He died in 1848. Greater part of his life was passed in his library.

Disrup'tion, the name commonly applied in Scotland to the act by which, in 1843, 474 ministers and professors of the Established Church gave up their livings to vindicate principles which they held to be essential to the purity of the church, and in harmony with its earlier history. See *Free Church*.

Diss, a town, England, Norfolk, on the slope of a hill 18 miles south by west from Norwich. It was formerly noted for the manufacture of 'Suffolk hempen cloth,' worsted yarn, and knit hosiery. Pop. 3845.

Dissei'zin, or DISSEISIN, in law, is the dispossessing one of a freehold estate, or interrupting his *seizin*. Of freeholds only can a *seizin* be had, or a disseizin done. Whether an entry upon lands is or is not a disseizin, will depend partly upon the circumstances of the entry, and partly upon the intention of the party, as made known by his words or acts.

Dissent'ers, the common name by which in Britain all Christian denominations, excepting that of the Established Churches, are usually designated, though in acts of parliament it generally includes only Protestant dissenters, Roman Catholics being referred to under their specific name. The most important bodies of English dissenters are the different bodies of Methodists, the Congregationalists, and the Baptists; and of Scotch dissenters, the Free Church and the United Presbyterian Church. The Non-conformists were dissenters from the English Church.

Dissentis', a town of Switzerland, canton Grisons, about 3800 ft. above the sea, at the junction of the Middle and Vorder Rhine, with a Benedictine abbey established in 614. Pop. 1300.

Dissociation, a chemical term used to express the partial decomposition which takes place when chemical compounds are exposed to a high temperature; as when by the passage of steam through a white-hot platinum tube some of it is decomposed and an explosive mixture of oxygen and hydrogen may be collected. In his writings on dissociation Ste. Claire Deville uses the term in a more extended sense, as denoting the separation of a body into its constituents (whether simple or compound) at a temperature inferior to that at which its composition is usually seen to take place.

Dissolving Views are paintings upon glass magnified and thrown with great distinctness upon a screen by means of one or two magic lanterns with strong lenses, and illuminated by the oxyhydrogen light. If one lantern is used the picture is drawn out of focus gradually, and a second substituted, which is brought gradually into focus, thus producing the haze and brilliancy which have gained this sort of exhibition its name. If two lanterns are used, they are placed

side by side with their lens tubes slightly convergent, so that the images may be superposed on the screen. By means of a revolving shutter either lantern can be wholly or partially shut off and the image of other lanterns be correspondingly disclosed.

Dis'sonance, in music, that effect which results from the union of two sounds not in accord with each other. The ancients considered thirds and sixths as dissonances; and, in fact, every chord except the perfect concord is a dissonant chord. The old theories include an infinity of dissonances, but the present received system reduces them to a comparatively small number. The most common are those of the tonic against the second, the fifth against the sixth, or (the most frequent of all) the fourth against the fifth.

Dis'taff, the first instrument employed in spinning. It consisted of a staff, on one end of which the wool or flax was rolled. The spinner held it in the left hand, and drew out the fibres with the right, at the same time twisting them. A small piece of wood called a spindle was attached to the thread, the weight of which carried it down as it was formed. When the spindle reached the ground the thread which had been spun was wound round it, and it was then again fastened near the beginning of the new thread.

Distemp'er, a disease of the dog commonly considered as of a catarrhal nature. In most cases a running from the nose and eyes is one of the first and chief symptoms, the defluction becoming after some time mucous and purulent. The animal is subject to violent fits of coughing combined with vomiting, loses its appetite, its flesh begins to waste, and if the disease be virulent, symptoms of affection of the brain manifest themselves, accompanied by fits, paralysis, or convulsive twitchings. In the first stage of the disease laxatives, emetics, and occasional bleeding are the principal remedies; diarrhœa should be checked by astringents, and to reduce the violence of the fits warm bathing and antispasmodics should be resorted to. The distemper is generally contagious, and occurs but once in a lifetime.

Distemper (Italian, *tempera*), in painting, a preparation of opaque colour mixed in a watery glue, such as size, white of egg, or gum. It is used now chiefly in scene-painting and in paper for walls, but was employed in the higher departments of art before the introduction of oil-painting in the 15th century. Distemper is painted on a dry surface, fresco on wet mortar or plaster.

Distich (dis'tik), a couplet of verses, especially one consisting of a Latin or Greek hexameter and pentameter, making complete sense.

Distillation, the volatilization and subsequent condensation of a liquid by a special apparatus, resulting in the separation of the liquid from a mixture. The operation is performed by heating the crude liquid or mixture in a retort or vessel known as the *body of the still*. This is made of various shapes and materials, and is closed with the exception of a slender neck which opens into the condenser, a long tube through which the hot vapour from the still is passed. The tube is kept at a sufficiently low temperature to cause the vapour to condense, the common method of securing this being to surround the tube with a constantly renewed stream

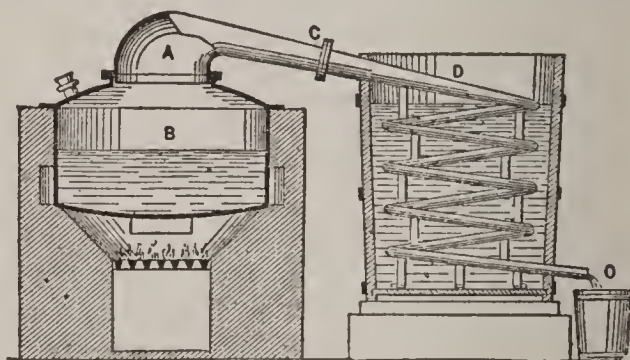

Distilling Apparatus.

of cold water. In some cases ice or a freezing mixture may be required to effect condensation. On a large scale the condensing tube is coiled round and round in a tub or box, and is known as a *worm*. From the end of it the vapour condensed into a liquid drops or distils into a receiver. The simplest case of distillation is that of water containing solid matter in solution, the solid matter remaining behind in the still or retort while the water trickles pure into the receiver. The cut, which represents a simple form of still, shows B, a copper boiler, the 'body' of the still, A being the 'head,' and C the 'neck,' which communicates with the spiral worm D placed in a vessel which contains cold water, the distilled liquid trickling out at O. The cold water round the worm requires to be continually renewed, as otherwise it gets heated. When the mixture to be distilled consists of two or more fluids of different boiling-points, such as alcohol and water, the more volatile comes off first, accompanied by a certain proportion of the vapour of the other, so that it is hardly possible completely to separate bodies by one

distillation. This is effected by repeated successive distillations of the liquid with or without the addition of substances to retain the impurities. When the production of one of the ingredients only is aimed at by this process, it is called *rectification*, but when it is desired to separate and collect all the liquids present, or to divide a mixture into portions lying within certain ranges of temperature ascertained either by the thermometer or by the amount of liquor run off, or by the appearance of the distillate, &c., the process is called *fractional distillation*. In the laboratory, distillation is employed for purifying water, for recovering alcohol and ether, for the preparation, purification, and separation of a great number of bodies. On the large scale distillation is employed in the preparation of potassium, sodium, zinc, mercury; of sulphuric acid, ether, chloroform, sulphide and chloride of carbon, essential oils and perfumes; purification of coal and wood tar, and the products obtained from them; and most extensive of all, the manufacture of whisky, brandy, or other spirit. Sea-water is also distilled in many cases for drinking or cooking purposes. *Destructive distillation* differs from the preceding in this respect, that the original substance is not merely separated into the bodies by the mixture of which it is formed, but is so acted on that it is completely decomposed, and bodies are produced which had no existence in the original matter. The term is restricted to the action of heat upon complex organic substances out of contact with the air. The products of destructive distillation are numerous and varied. On the manufacturing scale the process is conducted sometimes for one part, sometimes for another part of the products. Coal, for example, is distilled primarily for the gas, but also for ammoniacal water, benzol, anthracene, and sometimes for the sake of the fixed carbon or coke, the volatile portions being neglected and practically wasted. Wood is distilled partly for the sake of the pyroligneous acid and the tar, partly for the charcoal. Bones are distilled for the sake of the charcoal, though the oil is also collected. Shale is distilled solely for the sake of the oil.

Distinguished Service Order, an order instituted by Queen Victoria on September 6th, 1886, for the adequate reward of naval and military service. Foreign officers who have been associated in naval and military operations with British forces are eligible to be

honorary members, and the order ranks next to that of the Indian Empire. The badge is a gold cross enamelled white, edged gold, with the imperial crown on one side and the cipher V.R.I. on the other, each inclosed in a laurel wreath.

Dis'toma, a genus of trematode or suctional parasitical worms or flukes, inhabiting various parts in different animals. *D. hepaticum*, or common liver fluke, inhabits the gall-bladder or ducts of the liver in sheep, and is the cause of the disease known as the rot. They have also been discovered in man (though rarely), the horse, the hog, the rabbit, birds, &c. In form it is ovate, flattened, and presents two suckers (whence the name), of which the anterior is perforated by the aperture of the mouth. A branched water-vascular system is present, and opens posteriorly by a small aperture. All the animals of this genus present the phenomenon known as 'alternation of generation.'

Distress', in law, is the taking of a personal chattel of a wrong-doer or a tenant, in order to obtain satisfaction for the wrong done, or for rent or service due. If the party whose goods or cattle are seized disputes the injury, service, duty, or rent, on account of which the distress is taken, he may replevy the things taken, giving bonds, at the same time, to return them or pay damage in case the party making the distress shows that the wrong has been done, or the service or rent is due. Another description of distress is that of *attachment*, to compel a party to appear before a court when summoned for this purpose. The distresses most frequently made are on account of **rent and taxes and damage-feasance**.

Distribution of Animals. See *Zoology*.

Distribution of Plants. See *Botany*.

District Courts, an important series of courts in the U. States, each under a single judge, and having original jurisdiction in civil, criminal, and admiralty causes. They are about sixty in number, having been increased from time to time. Generally there is one for each state, but the larger states have more than one.

District of Columbia. See *Columbia*.

Districts, CONGRESSIONAL, the divisions in the United States which each return a member to Congress. Their number varies at different times, being fixed after each decennial census. At present they are 356.

Districts, MILITARY, fifteen districts into which for convenience of organization the United Kingdom is divided, eleven of them

being in England, and three in Ireland. Scotland forms but one military district. The head-quarters of the English districts are 1, London; 2, Dover; 3, Aldershot; 4, Chatham; 5, Colchester; 6, Guernsey; 7, Jersey; 8, York; 9, Portsmouth; 10, Devonport; 11, Woolwich. The head-quarters of the Scotch district are at Edinburgh. The head-quarters of the three Irish districts are at Dublin, Belfast, and Cork.

Ditch, a trench in the earth made by digging, particularly a trench for draining wet land, or for making a fence to guard inclosures, or for preventing an enemy from approaching a town or fortress. In the latter sense it is called also a *fosse* or moat, and is dug round the rampart or wall between the scarp and counterscarp. See *Fortification*.

Dithyram'bus, DITH'YRAMB, in Greek literature, a poem sung in honour of the god Bacchus or Dionysus, at his festivals. It was composed in a lofty and often inflated style: hence the term is applied to any poem of an impetuous and irregular character.

Ditmarshes (German, *Dithmarschen*), a district of Holstein, in Germany, consisting of a monotonous flat stretching along the German Ocean, between the mouths of the Elbe and the Eider, and so little raised above the sea as to require the protection of strong embankments. The area is 500 sq. miles, and the total pop. above 70,000.

Dit'tany, the popular name of the plants of the genus *Dictamnus*, an herb of the rue family (Rutaceæ), found in the Mediterranean region. The leaves are pinnate, the large white or rose-coloured flowers are in terminal racemes. The whole plant is covered with oily glands, and the secreted oil is so volatile that in hot weather the air round the plant becomes inflammable. *D. Fraxinella* and *D. albus* are found in gardens. The dittany of the United States is *Cunila Mariana*, a labiate plant. The dittany of Crete is *Origānum Dictamnus*, and the bastard dittany is a species of *Marrubium* (horehound), both labiates.

Dittay, in Scots law, a technical term signifying the matter of charge or ground of indictment against a person accused of a crime; also, the charge itself.

Diu, an island of Hindustan, belonging to the Portuguese, on the north-west coast, off the south extremity of Gujerat, from which it is separated by a very narrow channel. It is 7 miles in length, from E. to W., and 2 miles in greatest breadth from N.

to S. On a point on the east end of the island stands the town of Diu. It was formerly the seat of a considerable commerce, but is now a place of no importance. Pop. of island, 12,636.

Diuret'ics, medicines intended to increase the secretion and discharge of urine. They either act directly on the kidneys, exciting these organs to increased action; or indirectly by influencing the circulation first. Of the first class are squill, broom, juniper, alcohol, potash, &c.; of the second, digitalis, elaterium, cream of tartar, &c.

Diur'na, a name sometimes given to the diurnal lepidopterous insects or butterflies.

Divan', a Persian word having several significations. It is used in Turkey for the highest council of state, the Turkish ministry; and for a large hall for the reception of visitors. Among several oriental nations this name is given to certain collections of lyric poems by one author. The *divans* of Hafiz and Saadi, the Persian poets, are among the most important. In Western Europe the term is applied to a café, and to a kind of cushioned seat.

Divers, birds remarkable for the habit of diving. The divers (Colymbidæ) are a family of swimming birds (Natatores), characterized by a strong, straight, rather compressed pointed bill about as long as the head; a short and rounded tail; short wings; thin, compressed legs, placed very far back, and the toes completely webbed. They prey upon fish, which they pursue under water, making use partly of their wings, but chiefly of their legs and webbed feet in their subaqueous progression. The leading species are the great northern diver (*Colymbus glaciālis*), the red-throated diver (*C. septentrionālis*), and the black-throated diver (*C. arcticus*). These birds inhabit the Arctic seas of the New and Old Worlds; they are abundant in the Hebrides, Norway, Sweden, and Russia. The great northern diver, loon, or ember goose is about $2\frac{3}{4}$ feet long, and is of handsome plumage.

Div'idend, lit. what is to be divided, a term used in arithmetic and in reference to stocks, &c. In the latter sense it is the interest or profit of stocks divided among, and paid to, the proprietors. It also signifies the payment made to creditors out of the estate of a bankrupt.

Dividers, a pair of compasses or similar instrument.

Dividing Engine, a machine for marking the divisions on the scales of scientific,

mathematical, or other instruments. Some of these perform work of extraordinary fineness and accuracy.

Dividing Range, GREAT, an Australian chain of mountains, forming the watershed between the rivers flowing into the Pacific and those running westward. It is situated at an average distance of 30 miles from the sea, though in some places it recedes as much as 60 miles, and stretches from Cape York on the north to Wilson's Promontory on the south. Culminating point Mount Townshend (7353 feet).

Divi-divi, LIBI-DIBI, or LIBI-DAVI, the pods of *Cesalpinia coriaria*, a tree which grows in tropical America, and a member of the family which yields sapan, brazil, and other red woods. The pods are about 1 inch broad and 3 inches long, but are generally bent or curled up; are excessively astringent, containing a large proportion of tannic and gallic acid, for which reason they are used by tanners and dyers.

Divina Commedia. See *Dante*.

Divination, the act of divining; a foretelling future events, or discovering things secret or obscure, by the aid of superior beings, or by other than human means. In ancient times divination was divided into two kinds, *natural* and *artificial*. *Natural* divination was supposed to be effected by a kind of inspiration or divine afflatus; *artificial* divination was effected by certain rites, experiments, or observations, as by sacrifices, observation of entrails and flight of birds, lots, omens, position of the stars, &c. Among modes of divination were: *axinomancy*, by axes; *belomancy*, by arrows; *bibliomancy*, by the Bible; *oneiromancy*, by dreams; *pyromancy*, by fire, &c.

Divine Right, the claim set up by some sovereigns or their supporters to the absolute obedience of subjects as ruling by appointment of God, insomuch that, although they may themselves submit to restrictions on their authority, yet subjects endeavouring to enforce those restrictions by resistance to their sovereign's acts are considered guilty of a sin. This doctrine, so celebrated in English constitutional history, especially in the time of the Stuarts, may now be considered to be exploded.

Divine Service, TENURE BY, a species of tenure, now obsolete, by which the tenant held the land on condition of performing some divine service, such as saying so many masses, distributing a certain amount in alms, &c.

Diving, the art or act of descending into water to considerable depths, and remaining there for a time. The uses of *diving* are important, particularly in fishing for pearls, corals, sponges, examining the foundations of bridges, recovering valuables from sunken ships, and the like. Without the aid of artificial appliances a skilful diver may remain under water for two, or even three minutes; accounts of longer periods are doubtful or absurd. Various methods have been proposed and engines contrived to render diving more safe and easy. The great object in all these is to furnish the diver with fresh air, without which he must either make but a short stay under water or perish. See *Diving-bell, Diving-dress*.

Diving-bell, a contrivance for the purpose of enabling persons to descend and to remain below the surface of water for a length of time, to perform various operations, such as examining the foundations of bridges, blasting rocks, recovering treasure from sunken vessels, &c. Diving-bells have been made of various forms, more especially in that of a bell or hollow truncated cone, with the smaller end close, and the larger one, which is placed lowermost, open. The air contained within these vessels prevents them from being filled with water on submersion, so that the diver may descend in them and breathe freely for a long time, provided he can be furnished with a new supply of fresh air when the contained air becomes vitiated by respiration. The diving-bell is generally made of cast-iron, and has several strong convex lenses set in the upper side or roof, to admit light to the persons within. It is suspended by chains from a barge or lighter, and can be raised or lowered at pleasure upon signals being given by the persons within, who are supplied with fresh air injected into a flexible pipe by means of forcing pumps placed in the lighter, while the heated air escapes by a cock in the upper part of the bell. The illustration shows the most recent form of diving apparatus in use on the river Clyde, in which steam is applied to operate all the movements required. A form, called the *nautilus*, has been invented which enables the occupants, and not the attendants above, to raise or sink the bell, move it about at pleasure, or raise great weights with it and deposit them in any desired spot.

Diving-dress, a waterproof dress of india-rubber cloth used by professional divers, and covering the entire body except the head.

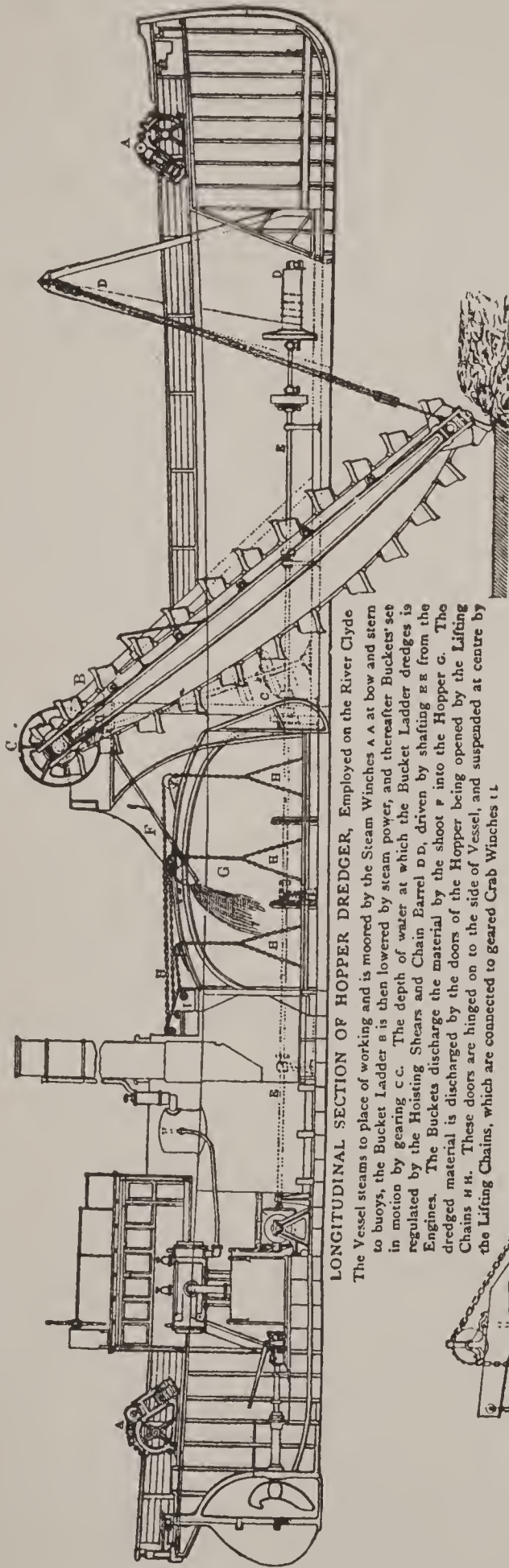

LONGITUDINAL SECTION OF HOPPER DREDGER, Employed on the River Clyde

The Vessel steams to place of working and is moored by the Steam Winches A A at bow and stern to buoys, the Bucket Ladder B is then lowered by steam power, and thereafter Buckets' set in motion by gearing C C. The depth of water at which the Bucket Ladder dredges is regulated by the Hoisting Shears and Chain Barrel D D, driven by shafting E E from the Engines. The Buckets discharge the material by the shoot F into the Hopper G. The dredged material is discharged by the doors of the Hopper being opened by the Lifting Chains H H. These doors are hinged on to the side of Vessel, and suspended at centre by the Lifting Chains, which are connected to geared Crab Winches I I.

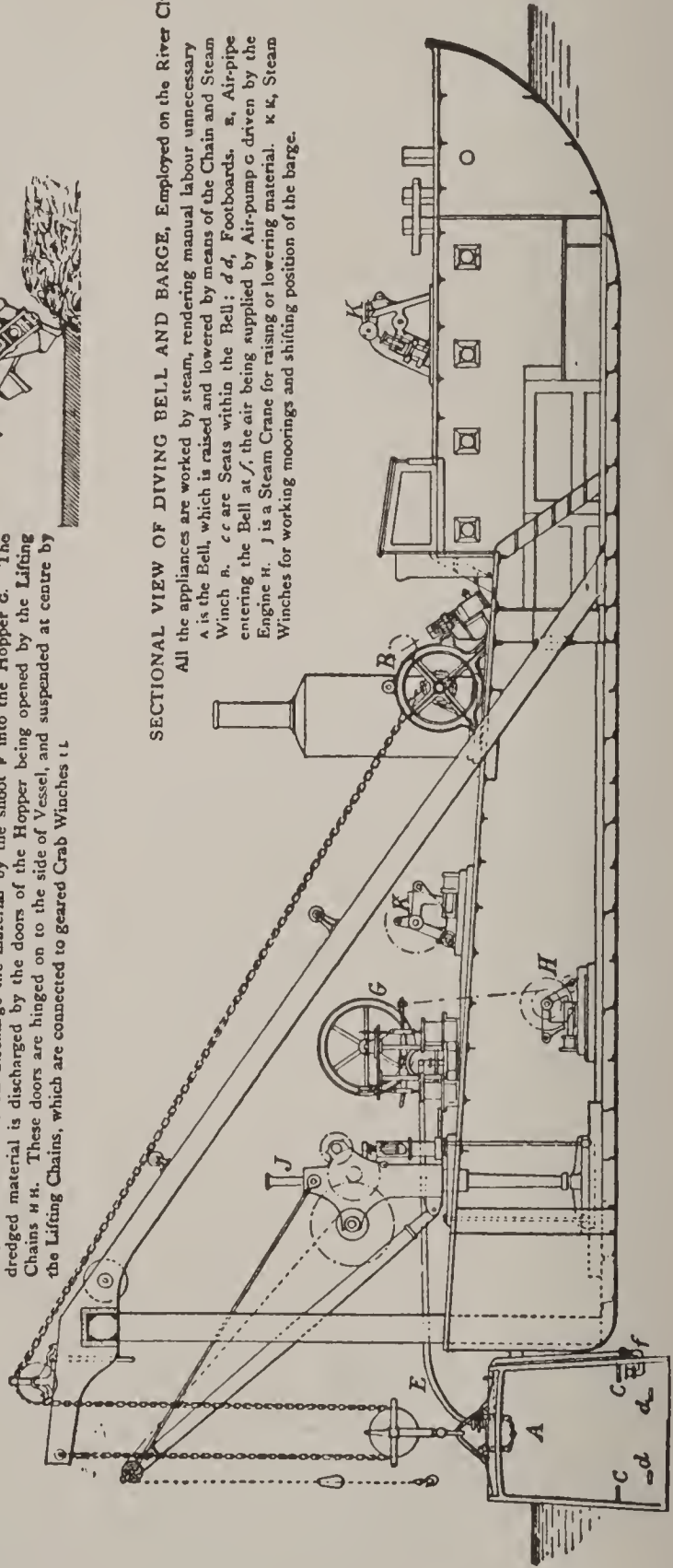

SECTIONAL VIEW OF DIVING BELL AND BARGE, Employed on the River Clyde.

All the appliances are worked by steam, rendering manual labour unnecessary. A is the Bell, which is raised and lowered by means of the Chain and Steam Winch B. C C are Seats within the Bell; D D, Footboards. E, Air-pipe entering the Bell at F, the air being supplied by Air-pump G driven by the Engine H. J is a Steam Crane for raising or lowering material. K K, Steam Winches for working moorings and shifting position of the barge.

DIVING-DRESS — DIVISIBILITY.

The dress has a neck-piece or breastplate, fitted with a segmental screw bayonet joint, to which the head-piece or helmet, the neck of which has a corresponding screw, can be attached or removed. The helmet has usually three eyeholes, covered with strong glass, and protected by guards. Air is supplied by means of a flexible tube which enters

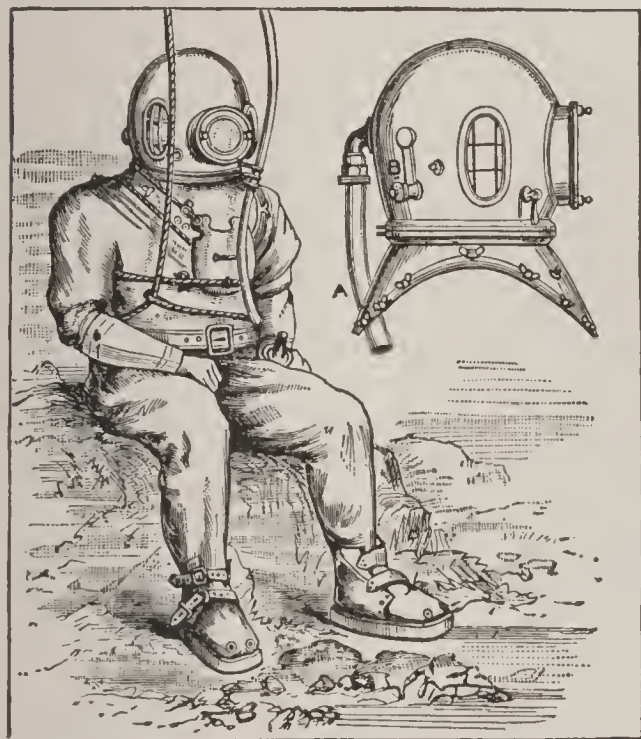

Diving-dress and Diving-helmet by Siebe, Gorman & Co.—*a*, Pipe by which air is supplied; *b*, valve by which it escapes.

the helmet and communicates with an air-pump above. To allow of the escape of the used air there is sometimes another flexible tube, which is led from the back part of the helmet to the surface of the water. But in the more improved forms of the dress, the breathed air escapes by a valve so constructed as to prevent water from getting in, though it lets the air out. Leaden weights are attached to the diver, and his shoes are weighted, that he may be able to descend a ladder, walk about below, &c. Communication can be carried on with those above by means of a cord running between the diver and the attendants; or he may converse with them through a speaking tube or a telephonic apparatus. One form of diving-dress makes the diver independent of any connection with persons above the water. It is elastic and hermetically closed. A reservoir containing highly compressed air is fixed on the diver's back, which supplies him with air by a self-regulating apparatus at a pressure corresponding to his depth. When he wishes to ascend he simply inflates

his dress from the reservoir. Another form, known as the Fleuss dress, makes the diver also independent of exterior aid. The helmet contains a supply of compressed oxygen, and the exhaled breath is passed through a filter in the breast-piece which deprives it of its carbonic acid, while the nitrogen goes back into the helmet to be mixed with the oxygen, the supply of which is under the diver's own control, and to be breathed over again. A diver has remained an hour and a half under 35 feet of water in this dress. The safe limit of depth at which operations can be carried on with the diving-dress is 120 to 150 feet. Diving for pearls, sponges, or corals is now to a great extent carried on by means of diving-dresses.

Divining Rod, a rod, usually of hazel, with two forked branches, used by persons who profess to discover minerals or water under ground. The rod, if carried slowly along by the forked ends, dips and points downwards, it is affirmed, when brought over the spot where the concealed mineral or water is to be found. The use of the divining-rod is still common in many parts, and quite recently various wonderful instances of its efficacy in discovering water have been published in respectable prints.

Divisibility, that general property of bodies by which their parts or component particles are capable of separation. Numerous examples of the division of matter to a degree almost exceeding belief, may be easily instanced. Thus glass test-plates for microscopes have been ruled so fine as to have 225,000 spaces to the inch. Cotton yarn has been spun so fine that one pound of it extended upwards of 1000 miles, and a Manchester spinner is said to have attained such a marvellous fineness that one pound would extend 4770 miles. One grain of gold has been beaten out to a surface of 52 square inches, and leaves have been made 367,500 of which would go to the inch of thickness. Iron has been reduced to wonderfully thin sheets. Fine tissue paper is about the 1200th part of an inch in thickness, but sheets of iron have been rolled much thinner than this, and as fine as one 4800th part of an inch in thickness. Wires of platinum have been drawn out so fine as to be only the 30,000th part of an inch in diameter. Human hair varies in thickness from the 250th to the 600th part of an inch. The fibre of the coarsest wool is about the 500th part of an inch in diameter, and that of the finest only the 1500th part. The silk

line, as spun by the worm, is about the 5000th part of an inch thick; but a spider's line is only the 30,000th part of an inch in diameter; insomuch that a single pound of this attenuated substance might be sufficient to encompass our globe. The trituration and levigation of powders, and the perennial abrasion and waste of the surface of solid bodies, occasion a disintegration of particles almost exceeding the powers of computation. The solutions of certain saline bodies, and of other coloured substances, also exhibit a prodigious subdivision of matter. A single grain of the sulphate of copper, or blue vitriol, will communicate a fine azure tint to five gallons of water. In this case the sulphate must be attenuated at least 10,000,000 times. Odours are capable of a much wider diffusion. A single grain of musk has been known to perfume a large room for the space of twenty years. At the lowest computation the musk had been subdivided into 320 quadrillions of particles, each of them capable of affecting the olfactory organs.

Division, in arithmetic, the dividing of a number or quantity into any parts assigned; one of the four fundamental rules, the object of which is to find how often one number is contained in another. The number to be divided is the *dividend*, the number which divides is the *divisor*, and the result of the division is the *quotient*. Division is the converse of multiplication.

Division, in military matters, a portion of an army consisting of two or more brigades, composed of the various arms of the service, and commanded by a general officer. In the navy, a select number of ships in a fleet or squadron of men-of-war. The term is now practically abolished since the introduction of gigantic heavily-armed iron-clad ships into the navy.

Division, in parliament, the mode of determining a question at the end of a debate. In the House of Commons the speaker puts the question, and declares whether in his opinion the 'Ayes' or the 'Noes' have it. Should his opinion not be acquiesced in by the minority, the house is cleared, and the 'Ayes' directed to go into the right lobby and the 'Noes' into the left, where they are counted by two tellers appointed for each party. In the House of Lords the two sides in a division are called 'Contents' and 'Not-contents.'

Division of Labour, a principle employed in great industries for the simplification of

the work to be done by each of the workmen engaged in it. The separation of complicated processes into a series of simple operations not only results in a great saving of time, but also demands much less ability on the part of the workman, in order that he may acquire the necessary skill in performing any particular operation. Owing to both of these causes, the saving of time, and the employment of cheaper labour, the cost of producing complicated articles is, by the application of this principle, immensely reduced. Division of labour tends to the invention of machinery, and to the effectual use of machinery when invented. It increases the skill and dexterity of the individual workman; it effects a great saving of time and capital, and it conduces to the more economical distribution of labour by classing work-people according to their capacity. It has, however, a deteriorating effect on the labourer's usefulness as an all-round workman.

Divorce is a separation, by law, of husband and wife, and is either a divorce *a vinculo matrimonii*, that is, a complete dissolution of the marriage bonds, or a divorce *a mensâ et thoro* (from bed and board), whereby the parties are legally separated, but not unmarried. The causes admitted by different codes of laws as grounds for the modification or entire dissolution of the marriage contract, as well as the description of tribunal which has jurisdiction of the proceedings, and the form of the proceedings, are various. Divorce was permitted by the law of Moses, but forbidden in the New Testament, except for unchastity. The early laws of Rome permitted the husband to divorce his wife for adultery and many other alleged offences. The facility of divorce continued, without restriction, under the Roman emperors, but as the modern nations of Europe emerged from the ruins of the Roman Empire, they adopted the doctrine of the New Testament. Marriage, under the Roman Church, instead of a civil contract, came to be considered a sacrament of the church, which it was unlawful to dissolve. The ecclesiastical courts could indeed annul a marriage, but only for a cause that existed at the time the marriage was contracted, such as prior contracts, impotency, &c. For any cause arising after marriage they could only pronounce a divorce *a mensâ et thoro*, which did not leave either party free to marry again, except by papal dispensation. A divorce *a vinculo*

matrimonii, for any cause arising subsequent to marriage, could formerly be obtained in England only by an act of parliament, and the ecclesiastical courts must have previously pronounced a divorce *a mensâ et thoro*. The act passed in 1857, however, established a new court for trying divorce causes, called the Court for Divorce and Matrimonial Causes, since absorbed into the Probate, Divorce, and Admiralty Division of the High Court of Justice. According to present practice the husband may obtain a divorce for simple adultery; but if the wife is the petitioner, she must show that her husband has been guilty of certain kinds of adultery, or of adultery coupled with desertion or gross cruelty. Either party may marry again after divorce. A divorce cannot be obtained if it appear that the petitioner has been guilty of the same offence, or that there is collusion between the parties to obtain a divorce, or if they have condoned the offence by living together as man and wife after discovery. The husband may claim damages from the adulterer, and the court may also order the adulterer to pay the costs of the proceedings, in whole or in part. The act also abolished divorces *a mensâ et thoro*, substituting, however, judicial separations. (See *Judicial Separation*.) A decree for a divorce is always in the first instance a *decree nisi* (which see). In Scotland, from the time of the Reformation, divorce might be obtained by either party on the ground of adultery, marriage being held to be only a civil contract, and as such under the jurisdiction of the civil courts. In the United States marriage is considered to be a civil contract, and the laws as to divorce, and the facility or difficulty of obtaining it, differ greatly in the several States.

Dix, JOHN A., statesman, was born in Boscawen, N. H., July 24, 1798. He received a military training, but afterwards studied law. At a critical time in 1861 he was appointed Secretary of the Treasury. In the civil war under the first call for troops he organized seventeen regiments. After the defeat at Bull Run by his energetic measures he saved Maryland from going over to the Confederate cause. In 1872 was elected Governor of New York. He was a man of culture and a distinguished orator. He died April 21, 1879.

Dixon, WILLIAM HEPWORTH, miscellaneous writer, born at Manchester 1821, died in London 1879. In 1849 he published a

memoir of Howard the philanthropist, which was followed by the Life of William Penn (1851), and by a work on Admiral Blake (1852). In 1853, after having been a contributor, he became chief editor of the Athenæum, a post which he retained till 1869. During this period he published several very popular works, including the Personal History of Lord Bacon, The Holy Land, and New America, the last being followed by Spiritual Wives. After his retirement from the Athenæum, and in the last ten years of his life, he gave to the world somewhere about twenty-five volumes of history, travel, and fiction, among others, Free Russia; Her Majesty's Tower; The Switzers; History of Two Queens, Catharine of Aragon and Anne Boleyn, &c.

Dixon, Edwards co., Ills.; manufacturing, flour, iron, lumber. Pop. 5161.

Dizful, a town of Persia, near the western boundary, on the river Dizful; a place of great trade and manufactures. Pop. 30,000.

Dizier (diz-i-ā), St., a town of North-eastern France, dep. Haute-Marne, on the Marne where it becomes navigable, 35 miles south-east of Châlons. There are several blast-furnaces and other works. Pop. 12,773.

Djidda. See *Jidda*.

Djokdjokarta, a Dutch residency in the island of Java, on the south coast, with a capital of the same name. Its forests abound in teak. Its natural fertility is great, and rice, coffee, and tobacco are extensively cultivated. It is ruled by a sultan who is dependent on the Dutch. Pop. 441,800. The town is large and regular, and contains the sultan's water-palace, and the seat of the Dutch resident, which is a fort commanding both the palace and the town. Pop. 45,000.

Dmitrof, a town of Russia, in the government and 45 miles north of Moscow. It has manufactures of cloths, leather, and porcelain. Pop. 8042.

Dmitrovsk, a town in Russia, in the government of Orel, on the highway from Moscow to Kiev. There are manufactures of leather and soap. Pop. 7603.

Dnieper (nē'pēr; Russian, *Dnjepr*, *dnyep*; anciently *Borysthēnēs*), a great river of Russia which rises in the government of Smolensk, flows first south-west, then south-east, and latterly again south-west to the Black Sea. It begins to be navigable a little above Smolensk, and has a total length, including windings, of 1230 miles. Among its tributaries are the Beresina, the Pripet, the

Desna, and the Psiol. In its lower course there are important fisheries. Between Kiev and Alexandrovsk it forms a series of cataracts, which are now being removed by blasting of the rocks. Since 1838 there have been steamboats on the river, and the trade carried by it is considerable.

Dniester (nēs'tēr; Russian, *Dnjestr*; anc. *Tyras*), a large river of Europe, which has its source in the Carpathian Mountains, in Austrian Galicia, enters Russia at Chotin, and empties itself into the Black Sea, after a course of about 750 miles. Its navigation is difficult on account of frequent shallows and rapids.

Doab' (that is, *Two Waters*), a name in Hindustan applied indiscriminately to any tract of country between two rivers. The tract between the Ganges and the Jumna is usually called *the Doab*; other similar tracts have their distinctive names, the Punjab being divided into five districts of this kind, Bari-Doab, Rechna Doab, Sindh-Sagar Doab, &c.

Dob'beran, or DOBERAN, a German watering-place in Mecklenburg-Schwerin, 2 or 3 miles from the Baltic. There are mineral springs, bathing establishments, &c. Pop. 3905.

Dobell', SYDNEY, English poet and man of letters, born in 1824. His first poem, *The Roman*, appeared in 1850, and was favourably received by the critics. Among his other works are *Balder*, *Sonnets on the War*, *England in Time of War*, &c. He died Nov. 14, 1874.

Döbeln (deu'beln), a town, kingdom of Saxony, about 40 miles south-east of Leipzig, with a great trade in grain, and manufactures of cloth, yarn, leather, lackered wares, &c. Pop. 11,972.

Doberan. See *Dobberan*.

Dobereiner's (dō'be-rī-nēr) **Lamp**, a contrivance for producing an instantaneous light, invented by Professor *Dobereiner*, of Jena, in 1824. The light is produced by throwing a jet of hydrogen gas upon recently-prepared spongy platinum, when the metal instantly becomes red hot, and then sets fire to the gas. The action depends upon the readiness with which spongy platinum absorbs gases, more especially oxygen gas. The hydrogen is brought into such close contact with oxygen (derived from the atmosphere) in the pores of the platinum that chemical union, attended with evolution of light, takes place.

Dobrud'sha, THE, a territory forming

part of the kingdom of Roumania, included between the Danube, which forms its boundary on the west and north, the Black Sea on the east, and on the south by a line stretching from Silistria to a point a few miles south of Mangalia. There are some fertile spots, but on the whole it is marshy and unhealthy. The population is of various nationalities, Roumanians, Bulgars, Greeks, Turks, and Jews. The inhabitants support themselves by rearing sheep and buffaloes. The principal town is Babadagh. Pop. about 100,000.

Docet'æ (from Greek *dokein*, to seem or appear), the name given, in the earlier ages of the church, to those who denied the reality of the human form of Christ, maintaining it to be merely a phantom or shadow. In the sense of regarding Christ's body as a heavenly and ethereal, instead of a human one, docetism had its partisans even among the orthodox.

Dock, a name applied to different plants of the genus *Rumex*, belonging to the rubarb family (Polygonaceæ). These are large herbaceous plants, with stout roots, alternate and often entire leaves, and bearing panicles of small greenish flowers. They are very troublesome as weeds, but the roots of some of them are used medicinally as astringents.

Docket, DOCQUET (dok'et), in law, a term variously used, as for a summary of a larger writing; a small piece of paper or parchment containing the heads of a writing; an alphabetical list of cases in a court, or a catalogue of the names of the parties who have suits depending in a court.

Docks are usually artificial inclosures for the reception of vessels, and provided with gates to keep in or shut out the tide. They are called *wet-docks* when they are intended to receive vessels for loading and unloading, the gates being in this case constructed so as to keep in the tide, and thus preserve the water within the docks as nearly as possible at the uniform level of high water. They are called *dry-docks*, or *graving-docks*, when they are intended to admit vessels to be examined and repaired, the gates in this case being such as to keep out the tide while the shipwrights are engaged on the vessel. There is another kind of dry-docks called *floating-docks*, which float on the surface of the water, and may be sunk sufficiently to allow of a vessel being floated into them, and then raised again, by pumping the water out of the tanks round the sides.

DOCKS.

One of the chief uses of a wet-dock is to keep a uniform level of water, so that the business of loading and unloading ships can be carried on without any interruption and without danger of damage to the vessel from straining, low tides, storms, &c. The first wet-docks constructed in England were those now called the Commercial Docks, in London, which existed in a much less ex-

tensive form so early as 1660. In 1800 the West India Docks were constructed, and were followed by the East India Docks, Millwall Docks, London Docks, the St. Katharine Docks, and the Victoria Docks, affording, together with those at Tilbury, more than 600 acres of water accommodation, besides wharf and warehouse grounds, where all kinds of appliances and machinery for the

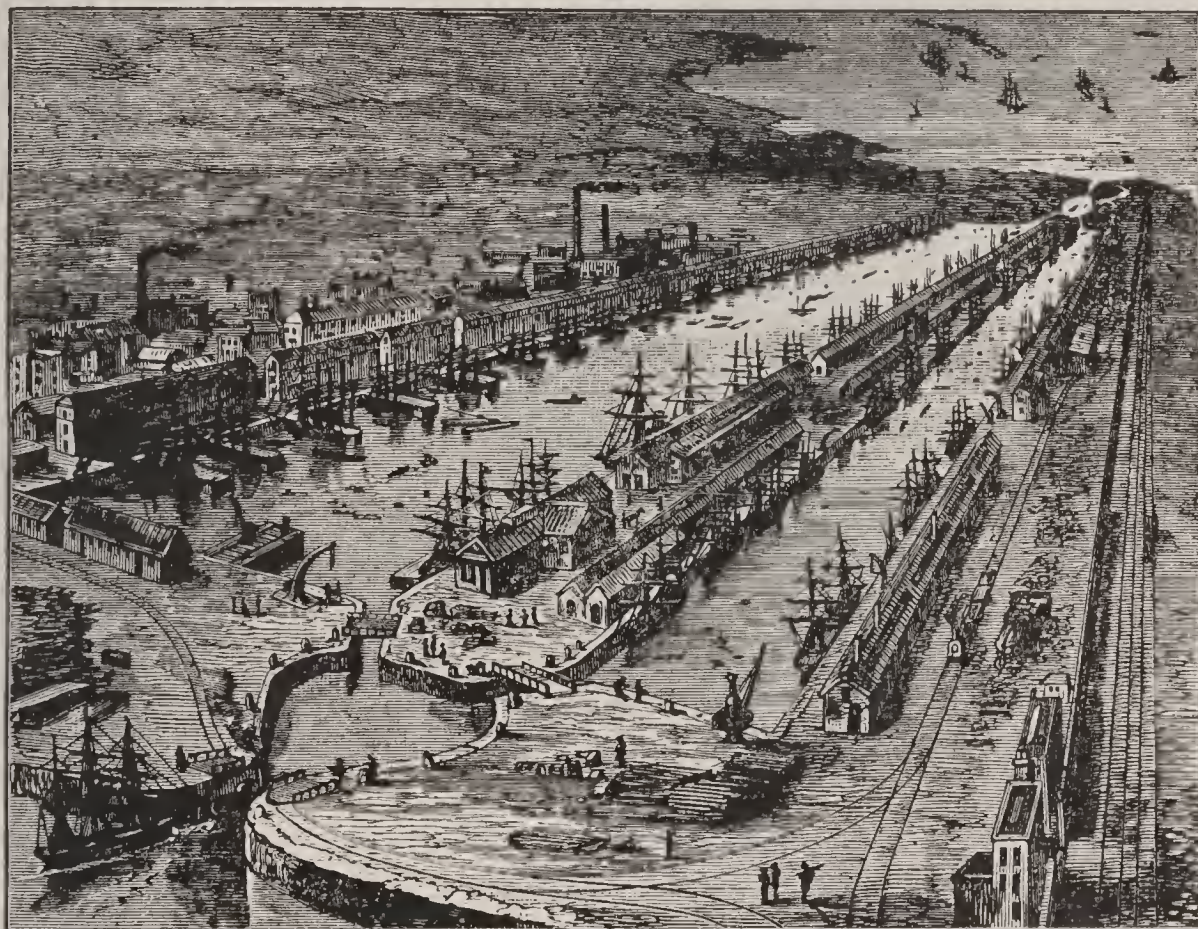

Bird's-eye view of the West India Docks, London.

speedy and convenient transfer of goods and cargoes are in use. Some of the warehouses are extremely capacious, the tobacco warehouse of the London Docks being itself nearly 5 acres in extent. Next after the London docks come those of Liverpool, which extend more than 6 miles along the north bank of the Mersey, and cover, together with the Birkenhead docks, nearly as large a total acreage as those of London. The other important British docks are those at Southampton, Bristol, Cardiff, Hull, Great Grimsby, Newcastle, Shields, Barrow, Leith, Glasgow, Dundee, &c.

Graving-docks are built of strong masonry, and their entrance is closed either by swinging gates opening in the middle, and when shut presenting a salient angle to the water in the river or harbour from which

the dock is entered, or by a framework called a *caisson*, built like the hull of a ship, with a keel and a stem at both ends. When the caisson is empty it floats, and may be removed to admit of a vessel being floated into the dock. The caisson being then placed at the entrance and filled with water, again sinks into the grooves intended for it and closes the graving-dock. The water is then pumped out, leaving the ship dry and supported by wooden blocks and props. With regard to floating-docks, a common type of construction is the iron floating-dock built in water-tight compartments, and not closed in at either end. It is sunk to the required depth by the admission of water into so many of the compartments, till the vessel to be docked can float easily above its bottom, and it is then raised by pumping

DOCK-WARRANTS — DOCTORS OF THE CHURCH.

out the water until the ship can be propped up as in a dry-dock.

A kind of dry-dock, called the *hydraulic lift dock*, consists of a double row of iron columns, each of which contains a hydraulic press. All these hydraulic presses can be worked simultaneously by a powerful steam-engine, and their combined action has the

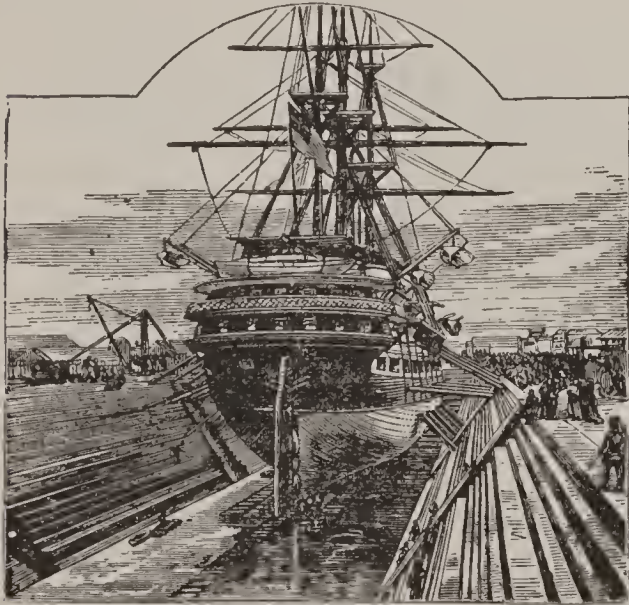

Dry or Graving Dock.

effect of raising a series of transverse iron girders stretching from the columns on one side to those of the other. An iron pontoon is first floated above these girders, and then sunk so as to rest on them, and the ship to be docked is floated above the pontoon and supported by blocks resting only upon the pontoon, so that the ship is in no way connected with the columns on each side. The hydraulic presses are then set to work, the girders with the pontoon and ship are raised high enough for the water to be run out of the pontoon, which is then sufficiently buoyant to float the ship. The pontoon may now be floated away clear of the dock, and another take its place. By this plan a number of vessels can be floated for overhauling and repairs in very shallow water and at comparatively slight expense. Docks in the U. States are not of so much importance to commerce as in England, the rise and fall of the tides being far less. Vessels can be loaded or unloaded without difficulty at the wharves of any of the Atlantic or Gulf ports. There are, however, some very fine docks for convenient handling of merchandise; for instance the Atlantic docks at Brooklyn.

Dock-yards, establishments supplied with all sorts of naval stores, materials and conveniences for the construction, repairs, and

equipment of ships of war. In England the royal dock-yards are at Chatham, Sheerness, Portsmouth, Devonport, and Pembroke, besides the Deptford and Woolwich store-yards. There are also royal dock-yards at Haulbowline in Cork Harbour, at the Cape of Good Hope, Gibraltar, Malta, Halifax, Bermuda, Antigua, Jamaica, Sierra Leone, Trincomalee, Singapore, Hong-Kong, Esquimalt (Vancouver's Island), Fernando Po, Sydney, and Shanghai. The dock-yards are under the direct control of the Admiralty, with a rear-admiral as superintendent. In the United States there are nine important navy-yards, located at Brooklyn, N. Y.; Boston, Mass.; Portsmouth, N. H.; League Island, Pa.; Portsmouth, Va.; Mare Island, Cal.; New London, Conn.; Pensacola, Fla.; and at Washington, D. C.

Doctor, a term literally signifying teacher. In the middle ages, from the twelfth century, it came into use as a title of honour for men of great learning, such as Thomas Aquinas (Doctor Angelicus), Duns Scotus (Doctor Subtilis), &c. It was first made an academical title by the University of Bologna, and emperors and popes soon afterwards assumed the right of granting universities the power of conferring the degree in law. The faculties of theology and medicine were soon included, but for a long time the faculty of arts retained the older title of *Magister*, till the German universities substituted that of Doctor. The title of Doctor is in some cases an honorary degree, and in other cases (as in medicine and science) conferred after examination. The title of D. C. L. (Doctor of Civil Law), for example, at the University of Oxford and at Trinity College, Dublin, is an honorary degree, and so also are those of D. D. (Doctor of Divinity) and LL. D. (Doctor of Laws) at the Scotch universities. The popes and the archbishops of Canterbury exercise the right of conferring the degree of Doctor both in law and divinity.

Doctor's Commons was a college founded for the Doctors of the Civil Law in London, and was at one time the seat of the court of arches, the archdeacon's court, the court of admiralty, &c. The practitioners in these courts were called advocates and proctors. In 1857 an act was passed empowering the college to sell its property and dissolve, and making the privileges of the proctors common to all solicitors.

Doctors of the Church, a name given to four of the Greek Fathers (Athanasius, Basil,

Gregory Nazianzen, and Chrysostom) and three of the Latin Fathers (Jerome, Augustine, and Gregory the Great). The Roman Catholic Church, however, recognizes seventeen 'Doctors of the Church,' including, besides those already mentioned, Chrysologus, Leo, Isidore, Peter Damian, Anselm, Bernard of Clairvaux, Thomas Aquinas, Bonaventura, and Alphonsus of Liguori. The title is conferred only after death.

Doctrinaires, a section of French politicians, represented by the Duc de Broglie, Royer-Collard, Guizot and others, who became prominent after the Restoration in 1815. They favoured a constitutional monarchy with a balance of powers similar to that which then existed in Britain. In the chambers they thus occupied a place between radicals and ultra-royalists. They received the name of *doctrinaires* because they were looked upon more as theoretical constitution-makers than practical politicians, and the term is now used with a wider application to political theorists generally.

Dodder, the common name of the plants of the genus *Cuscuta*, a group of slender, branched, twining, leafless pink or white annual parasites. The seeds germinate on the ground, but the young plant shows its parasitic habit by speedily attaching itself to some other plant, from which it derives all its nourishment. Four species are common in England. They are chiefly natives of temperate climates, and are often



Lesser Dodder (*Cuscuta Epithimum*).

very destructive to flax, clover and other crops. There are fifty species in two genera.

Doddridge, PHILIP, D.D., an English Dissenting divine, born in London in 1702. He was an earnest pastor, and the author of many hymns, devotional treatises, &c.

The Rise and Progress of Religion in the Soul and The Family Expositor are amongst the best known works. He died in 1751.

Dodecagon, a figure inclosed by twelve equal straight lines.

Dodecahedron, a regular solid contained under twelve equal and regular pentagons, or having twelve equal bases.

Dodecandria (Greek *dōdeka*, twelve), in botany, the twelfth class of Linnæus, comprising plants having twelve to eighteen stamens.

Dodo (*Didus ineptus*), an extinct genus of birds once abundant on the island of



Dodo, from painting in the Belvedere, Vienna.

Mauritius, and assigned by naturalists to the order Columbæ or pigeons, though an extreme modification of the type. It was a massive clumsy bird, larger than a swan, covered with down instead of feathers, with short ill-shaped legs, a strong bulky hooked beak, and wings and tail so short as to be useless for flight. Its extinction was due to its organization not being adapted to the new conditions which colonization and cultivation introduced.

Dodo'na, a celebrated locality of ancient Greece, in Epirus, where was one of the most ancient Greek oracles. It was a seat of Zeus, whose communications were announced to the priestesses in the rustling of the leaves on its oak-tree, and the murmuring of water which gushed forth from the earth.

Dodsley, ROBERT, English poet and dramatist, born in 1703, died in 1764. Among other things he wrote a tragedy, entitled Cleone, which had some success on the stage. A selection of Fables in prose, with an Essay on Fables prefixed, was one of his latest productions. He planned the Annual Register (commenced in 1758); the Collection of Old Plays, twelve vols. 12mo, which now chiefly sustains his name as a publisher; and the Collection of Poems by Different Hands, six vols. 12mo.

Doe, JOHN, and RICHARD ROE, two fictitious personages of the English law who formerly appeared in a suit of ejectment. This fictitious form of procedure was abolished in 1852.

Doesborgh (dös'borh), a fortified town of Holland, prov. Gelderland, at the junction of the Old and the New Yssel. Pop. 4484.

Dog (*Canis vulgāris*), a digitigrade, carnivorous animal, forming the type of the genus *Canis*, which includes also the wolf, the jackal, and, as a sub-genus, the fox. The origin of the dog is a much-debated question, some considering the breed derived from the wolf, an opinion which is based on resemblances of structure, the susceptibility which the wolf shows of being domesticated, the fact of the two animals breeding together and producing fertile young, and the equality in the period of gestation. But all these points are subject to exceptions and reservations which make the matter doubtful. It is generally agreed that no trace of the dog is to be found in a primitive state, the dhole of India, and dingoo of Australia being believed to be wild descendants from domesticated ancestors. Several attempts to make a systematic classification of the varieties of dogs have been made but without much success, it being difficult in many cases to determine what are to be regarded as types, and what as merely mongrels and cross-breeds. Colonel Hamilton Smith divides dogs into six groups as follows:—(1) *Wolf-dogs*, including the Newfoundland, Esquimaux, St. Bernard, shepherd's dog, &c.; (2) *Watch-dogs and Cattle-dogs*, including the German boar-hound, the Danish dog, the matin dog, &c.; (3) *Greyhounds*, the lurcher, Irish hound, &c.; (4) *Hounds*, the bloodhound, staghound, foxhound, setter, pointer, spaniel, cocker, poodle, &c.; (5) *Cur-dogs*, including the terrier and its allies; (6) *Mastiffs*, including the different kinds of mastiffs, bull-dog, pug-dog, &c. (See the different articles.) Dogs have in the upper jaw six incisors, two strong curved canines, and six molars on each side, the first three, which are small and have cutting edges, being called false molars; in the lower jaw are six incisors, two canines, and on each side seven molars. The fore-feet have five toes, the hind-feet four or five; the claws are strong, blunt, and formed for digging, and are not retractile. The tail is generally long, and is curled upwards. The female has six to ten mammæ; she goes with young nine weeks

as a rule. The young are born blind, their eyes opening in ten to twelve days; their growth ceases at two years of age. The dog commonly lives about ten or twelve years, at the most twenty. By English law it is prohibited to use dogs for purposes of draught.

Dog-bane (*Apocynum androsæmifolium*), an American plant found from Canada to Carolina, belonging to the natural order Apocynaceæ (which see). The whole plant is milky; the root is intensely bitter and nauseous, and is employed in America instead of ipecacuanha. Another species (*A. cannabinum*) yields a useful fibre, and is known as Canada or Indian hemp.

Dog-cabbage. See *Dog's-cabbage*.

Dog-cart, a sort of double-seated gig for four persons, those before and those behind sitting back to back; it is often furnished with a boot for holding dogs.

Dog-days, the name applied by the ancients to a period of about forty days, the hottest season of the year, at the time of the heliacal rising of Sirius, the dog-star. The time of the rising is now, owing to the precession of the equinoxes, different from what it was to the ancients (1st July); and the dog-days are now counted from 3d July to Aug. 11, that is, twenty days before and twenty days after the heliacal rising.

Doge (dōj; from Latin *dux*, a leader, later a duke), formerly the title of the first magistrates in the Italian republics of Venice and Genoa. The first doge of Venice elected for life was Paolo Anafesto, in 697; and in Genoa, Simon Boccanera, in 1339. In the former city the dignity was always held for life; in the latter, in later times, only for two years. In both cities the office was abolished by the French in 1797.

Dog-fish, a name given to several species of small shark, common around the British isles. The rough skin of one of the species (*Scyllium catulus*), the lesser-spotted dog-



Small-spotted Dog-fish (*Scyllium catulus*).

fish, is used by joiners and other artificers in polishing various substances, particularly wood. This species is rarely 3 ft. long. *S. canicūla*, the greater dog-fish, is in length from 3 to 5 feet. It is blackish-brown in colour, marked with numerous small dark spots. Both species are very voracious and

destructive. Their flesh is hard, dry, and unpalatable. The common or picked dogfish (*Acanthias vulgāris*) is common in British and N. American seas, and is sometimes used as food. It is fierce and voracious.

Dogger, a Dutch vessel equipped with two masts and somewhat resembling a ketch.



Dutch Dogger.

It is used particularly in the German Ocean for the cod and herring fisheries.

Dogger-Bank, an extensive sand-bank of the German Ocean, celebrated for its cod-fishery. It commences about 36 miles east of Flamborough Head and extends E.N.E. to within 60 miles of Jutland, in some places attaining a breadth of about 60 miles, though it terminates merely in a point. Where shallowest the water over it is 9 fathoms.

Dogget's Coat and Badge, a prize for a rowing-match on the Thames, which takes place every year on the 1st of August. The prize is an orange waterman's coat and a badge representing the white horse of Hanover. The match is open to six young watermen whose apprenticeship ends the same year. It was instituted by a popular actor, Thomas Dogget, a native of Dublin.

Dog-grass. Same as *Couch-grass*.

Dog-lichen, the popular name of a plant, *Peltidea canīna*, common on damp ground, stones, and trunks of trees. It was formerly supposed to be a specific for hydrophobia. Also known as *Ash-coloured Ground Liverwort*.

Dogma, an article of religious belief, one of the doctrines of the Christian faith. The history of dogmas, as a branch of theology, exhibits in a historical way the origin and the changes of the various Christian systems of belief, showing what opinions were received by the various sects in differ-

ent ages of Christianity, the sources of the different creeds, by what arguments they were attacked and supported, what degrees of importance were attached to them in different ages, the circumstances by which they were affected, and the mode in which the dogmas were combined into systems. Lectures on this subject are common in the German universities.

Dogmat'ics, a systematic arrangement of the articles of Christian faith (dogmas), or the branch of theology that deals with them. (See *Dogma*.) The first attempt to furnish a complete and coherent system of Christian dogmas was made by Origen in the 3d century.

Dog-parsley, same as fool's parsley.

Dog-rose, the *Rosa canīna*, or wild brier, nat. order Rosaceæ. By the Dutch invention of forming standards much use is made of the Dog-rose for budding purposes.

Dog's-bane. See *Dog-bane* and *Apocynaceæ*.

Dog's-cabbage, **DOG-CABBAGE**, *Thelygōnum Cynocrambe*, a smooth succulent herb, nat. order Chenopodiaceæ, found in the south of Europe. Though it is slightly acrid and purgative it is sometimes used as a pot herb.

Dog's-fennel, a British plant found in cultivated fields (*Anthēmis Cotūla*), with acrid, emetic properties. It derives its name of dog's-fennel from some resemblance of its leaf to fennel and from its bad smell.

Dog's-mercury, *Mercuriālis perennis*, nat. order Euphorbiaceæ, a herb common in Britain. It has poisonous properties, and may be made to yield a fugitive blue dye.

Dog's-tail Grass (*Cynosūrus*), a genus of grasses. *Cynosūrus cristātus* is a perennial found wild all over Great Britain in pastures, lawns, and parks. Its roots are long and wiry, and descending deep into the ground ensure the herbage against suffering from drought. Its stem is from 1 to 2 feet high and its leaves are slightly hairy.

Dog-star, a name for Sirius, the star that gives their name to the dog-days (which see).

Dog's-tooth Ornament, an architectural ornament or moulding consisting of square four-leaved flowers with project-

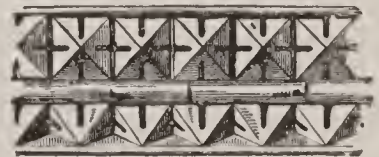

Dog's-tooth Ornament.

ing centres placed in close contact with each other. It is the characteristic decorated moulding of Early English architecture

Dog's-tooth Violet, *Erythronium dens-canis*, a liliaceous plant grown in gardens, so called from the appearance of its white bulbs.

Dog-tooth, or CANINE TOOTH, one of the teeth in the human jaw placed between the foreteeth and the grinders. They are sharp-pointed resembling a dog's teeth.

Dog-tooth Spar, a form of calcic carbonate or calc-spar found in Derbyshire and other parts of England, and named from a supposed resemblance to a dog's tooth.

Dog-watch, a nautical term distinguishing two watches of two hours each (4 to 6 P.M. and 6 to 8 P.M.). All the other watches count four hours each, and without the introduction of the dog-watches the same hours would always fall to be kept as watch by the same portion of the crew.

Dogwood, a common name of trees of the genus *Cornus*, but specifically applied in Britain to *C. sanguinea*. It is a common shrub in copses and hedges in England; the small cream-white flowers are borne in dense roundish clusters. The branchlets and leaves become red in autumn. The wood is used for skewers and for charcoal for gunpowder. The *C. mascula* is known as the cornel-tree. *Cornus florida* and other American species are also called dogwood. The 'poison dogwood' of America is *Rhus venenata*, one of the sumachs. See *Cornel*, *Cornaceæ*.

Doiley, a small ornamental napkin used at table to set glasses on at dessert.

Doit, an ancient Scottish coin, of which eight or twelve were equal to a penny sterling. In the Netherlands and Lower Germany there was a coin of similar name and value.

Dolab'ra, the Latin name for a celt. See *Celts*.

Dolce (dol'chā), or DOLCEMENTE, in music, an instruction to the performer that the music is to be executed softly and sweetly.

Dolci (dol'chē), CARLO, celebrated painter of the Florentine school, was born at Florence in 1616, and died there in 1686. His works, principally heads of madonnas, saints, &c., have a character of sweetness and melancholy. Among his chief productions are St. Cecilia at the Organ and Herodias with the Head of John the Baptist, both in the Dresden Gallery, and St. Andrew in Prayer, at the Pitti Gallery.

Dolcinites, a Christian sect of Piedmont, so named from their leader Dolcino. They arose in 1304 as a protest against Papacy, but were suppressed by the troops of the Inquisition in 1307.

Dol'drums, among seamen, the parts of the ocean near the equator that abound in calms, squalls, and light baffling winds; otherwise known as the horse-latitudes.

Dôle, a town in France, Jura, 26 miles south-east of Dijon. It is of Roman origin, was long the capital of Franche Comté, and has some interesting antiquities. The manufactures are Prussian blue, hosiery, ironware, leather, &c. Pop. 10,617.

Dol'erite, a variety of trap-rock composed of augite and labradorite with some titaniferous magnetic iron ore and other minerals.

Dolgel'ley, a town of Wales, capital of Merioneth county, near the foot of Cader Idris. It has manufactories of woollens, flannels, and cloths. Pop. 2357.

Dolichocephalic (dol-i-ko-se-fal'ik), long-headed: a term used in ethnology to denote those skulls in which the diameter from side to side is less in proportion to the longitudinal diameter (*i.e.* from front to back) than 8 to 10.

Dol'ichos (-kos), a genus of leguminous plants, sub-order Papilionaceæ. They are found in the tropical and temperate regions of Asia, Africa, and America, and all produce edible legumes. *D. sesquipedālis*, which is also grown in the south of France, has pods a foot in length and containing seven to ten kidney-shaped seeds. *D. lignōsus* is one of the most common kidney beans in India. *D. tuberosus* of Martinique has a fleshy tuberous root which is an article of food.

Dol'ichosaurus ('long lizard'), an extinct snake-like reptile found in the chalk, whose remains indicate a creature of aquatic habits from 2 to 3 feet in length.

Dollar, a silver or gold coin of the United States, of the value of 100 cents, or rather above 4s. sterling. The same name is also given to coins of the same general weight and value, though differing somewhat in different countries, current in Mexico, a great part of South America, Singapore, the Philippine Islands, &c. The name is from the Dutch (also Danish and Swedish) *daler*, from Ger. *thaler*, so named from Ger. *thal*, a dale, because first coined in Joachim's *Thal*, in Bohemia, in 1518.

Dollar, a village, Scotland, county Clackmannan, 10 miles E. by N. Stirling, noted for its academy, founded by a Mr. John Macnab, who left £90,000 for this purpose. The building, a handsome structure in the Grecian style, was erected in 1819. The population of the village is 2014.

Dollart, THE, a gulf of the German Ocean, at the mouth of the Ems, between the Dutch province of Groningen and Hanover. It was originally dry land, and was formed by irruptions of the sea which took place in 1277 and 1530, overwhelming thirty-four large villages and numerous hamlets.

Döllinger (deul'ing-ër), JOHANN JOSEPH IGNAZ, a celebrated German theologian and leader of the Old Catholic party, was born at Bamberg, in Bavaria, in 1799. In 1822 he entered the church, and soon after published *The Doctrine of the Eucharist during the First Three Centuries*, a work which won him the position of lecturer on church history at the University of Munich. In later years he took an active part in the political struggles of the time as representative of the university in the Bavarian parliament, and as delegate at the Diet of Frankfort voted for the total separation of church and state. In 1861 he delivered a course of lectures, in which he attacked the temporal power of the Papacy. But it was first at the Ecumenical Council of 1869-70 that Dr. Döllinger became famous over Europe by his opposition to the doctrine of Papal infallibility. In consequence of his opposition to the Vatican decrees he was excommunicated in 1871 by the Archbishop of Munich. A few months later he was elected rector of the University of Munich, and in 1873 rector of the Royal Academy of Science. Among his numerous works we may notice *Origins of Christianity*, *A Sketch of Luther*, *Christianity and the Church*, &c. He died in 1890.

Dol'ond, JOHN, an English optician of French descent, born in 1706, died in 1761. He devoted his attention to the improvement of refracting telescopes, and succeeded in constructing object-glasses in which the refrangibility of the rays of light was corrected. Subsequent members of the family have distinguished themselves in optics, astronomy, &c.

Dol'man, a long robe worn by the Turks as an upper garment. It is open in front, and has narrow sleeves. It has given its name to a kind of loose jacket worn by ladies.

Dol'men, a name sometimes used as equivalent to *cromlech*, sometimes in a distinctive sense. Sir John Lubbock maintains that *cromlech* should be applied to a stone circle, *dolmen* to a stone chamber, such circle or chamber consisting of huge stones set up often in prehistoric times for religious or

sepulchral purposes or as memorials of some important event. See *Cromlech*.

Dolomieu (dol-o-myeu), DÉODAT GUY SILVAIN TANCRÈDE GRATET DE, a French geologist and mineralogist, born in 1750 at Dolomieu (Isère). After some years of military service he devoted himself to geological researches. He accompanied the French expedition to Egypt, but was shipwrecked on his return off the coast of Taranto, and imprisoned and harshly treated by the Neapolitan government. He died in 1801. Among his works are *Voyages aux Iles de Lipari, &c.* (1783); *Sur le Tremblement de Terre de la Calabre* (1784); *Philosophie minéralogique* (1802).

Dolomite, a mineral, also called magnesian limestone. It is composed of carbonate of calcium and carbonate of magnesium, and varies from gray or yellowish-white to yellowish-brown. It abounds in the Apennines, Tyrol, Switzerland, Tuscany, N. America, &c., and in England extends from S. Shields to Nottingham. A variety called *bitter spar*, and sometimes *rhombspar*, is found in crystals having the form of a rhomboid; colour grayish, yellowish, or reddish-brown, easily scratched with the knife; semi-transparent. A second variety is denominated *pearl spar*, which has crystals of curvilinear faces and a pearly lustre.

Dolomite Mountains, DOLOMITE ALPS, a group of European mountains belonging partly to Tyrol, partly to North Italy, and having the Piave and Rienz on the east, the Adige and Eisack on the west. They are named from the prevalence of the mineral dolomite, and present most interesting and picturesque scenery, the peaks being endlessly varied in form. The highest summits are *Palle di San Martino* (10,968 ft.); *Sorapiss* (10,798), and *Monte Tofana* (10,715).

Dolphin (*Delphinus*), a cetaceous animal,



Common Dolphin (*Delphinus Delphis*).

forming the type of a family (Delphinidæ) which includes also the porpoises and narwhal. Dolphins are cosmopolite animals,

inhabiting every sea from the equator to the poles; they are gregarious, and swim with extraordinary velocity. The common dolphin (*D. delphis*) measures from 6 to 10 feet in length, has a long, sharp snout with numerous nearly conical teeth in both jaws; its flesh is coarse, rank, and disagreeable, but is used by the Laplanders as food. It lives on fish, mollusca, &c., and often may be seen in numbers round shoals of herring. The animal has to come to the surface at short intervals to breathe. The blow-hole is of a semilunar form, with a kind of valvular apparatus, and opens on the vertex, nearly over the eyes. The structure of the ear renders the sense of hearing very acute, and the animal is observed to be attracted by regular or harmonious sounds. One or two young are produced by the female, who suckles and watches them with great care and anxiety, long after they have acquired considerable size. Compactness and strength are the characteristics of the genus.—The name is also commonly but improperly given to a fish, *Coryphæna hippūris*, a member of the mackerel family, the beauty of whose colours when dying has been much celebrated by poets. They abound within the tropics, are about 4 or 5 feet long, very swift in swimming, and are used as food, though said sometimes to be poisonous.

Dom, a Portuguese title corresponding with the Spanish *Don*.

Domain, same as *Demesne* (which see); also applied especially to crown lands or government lands.—*Right of eminent domain*, the dominion of the sovereign power over all the property within the state, by which it is entitled to appropriate any part necessary to the public good, compensation being given.

Dombrowski (-brov'skē), JAN HENRYK, a Polish general, distinguished in the wars of Napoleon, was born in 1755. He supported the rising of the Poles under Kosciusko in 1794. In 1796 he entered the service of France, and at the head of a Polish legion rendered signal services in Italy in 1796–1801. He took a distinguished part in the invasion of Russia in 1812, and also in the campaign of 1813. After Napoleon's abdication he returned to Poland, and the year following was made a Polish senator by Alexander I. He died in 1818.

Dome, a vaulted roof of spherical or other curvature, covering a building or part of it, and forming a common feature in Byzantine and also in Renaissance architecture. Cu-

pola is also used as a synonym, or is applied to the interior, dome being applied to the exterior. (See *Cupola*.) Most modern domes are semielliptical in vertical section, and are constructed of timber; but the ancient domes were nearly hemispherical

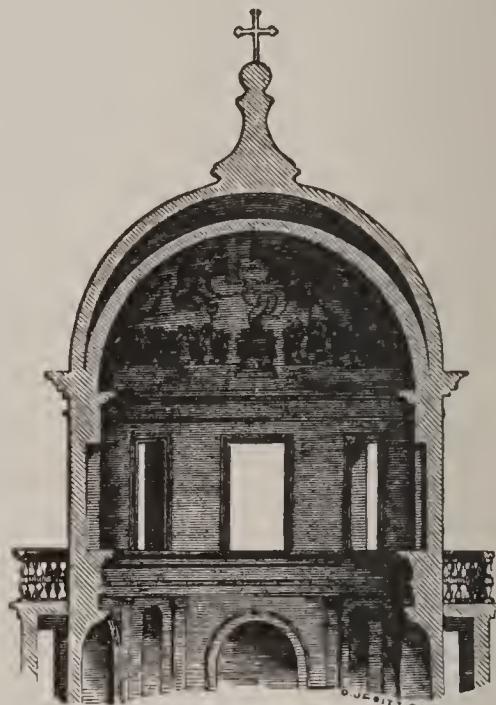

Section of Dome of San Pietro in Montorio, Rome: end of 15th Century.

and constructed of stone. Of domes the finest, without any comparison, ancient or modern, is that of the Rotunda or Pantheon at Rome (142½ feet internal diameter and 143 feet internal height), erected under Augustus, and still perfect. Among others the most noteworthy are St. Sophia at Constantinople (104 × 201 feet), the cathedral of Santa Maria del Fiore at Florence (139 × 310 feet), St. Peter's at Rome (139 × 330 feet), St. Paul's, London (112 × 215 feet), the Hotel des Invalides (80 × 173 feet), and the church of St. Geneviève at Paris (67 × 190 feet). The figures represent the internal diameter and height in English feet. The finest dome in America is that of the Capitol at Washington, built of cast-iron.

Domenichino (dō-men-i-kē'nō), *Domenico Zampieri*, an Italian painter of great eminence, of the Lombard school, born at Bologna in 1581 or 1582. He studied under Annibal Carracci, and afterwards went to Rome, where he became painter to Pope Gregory XV. Among his best works are the Communion of St. Jerome in the Vatican Museum, the History of Apollo, the Martyrdom of St. Agnes, and the Triumph of David. He died at Naples April 15, 1641.

Domesday (or **DOOMSDAY**) **Book**, a book containing a survey of all the lands in England, compiled in the reign and by the order of William the Conqueror. The survey was made by commissioners, who collected the information in each district from a sworn jury consisting of sheriffs, lords of manors, presbyters, bailiffs, villeins—all the classes, in short, interested in the matter. The extent, tenure, value, and proprietorship of the land in each district, the state of culture, and in some cases the number of tenants, villeins, serfs, &c., were the matters chiefly recorded. The survey was completed within a year. Northumberland, Durham, Cumberland, and Westmoreland were not included in the survey, probably for the reason that William's authority was not then (1086) settled in those parts. The Domesday Book consists of two volumes, one folio and one quarto. It has been twice republished, the last time (1861-65) in perfect facsimiles of the original.

Domestic Animals, such as are reared and kept by man, and are to some extent in a tame state; as the dog, cat, ox, sheep, swine, horse, ass, elephant, camel, llama, reindeer, &c.

Domfront (doŋ-frōŋ), a town, France dep. Orne, picturesquely situated on a steep rock above the Varenne, 35 miles w.n.w. of Alençon. Pop. 4866.

Dom'icile, in law, the place where a person has a home or established residence. Domicile is often an important question in determining the efficacy of legal citations, the validity of marriage, the right of succession to property, &c. For some purposes what is called a temporary domicile is sufficient, but in questions of marriage and succession it is the permanent domicile that determines the decision. A permanent domicile may be constituted by birth, by choice, or by operation of the law. To constitute a domicile by choice both actual residence and the intention to make it the permanent home are required. It is a legal principle that the wife takes the domicile of her husband. As a general rule the old domicile, and especially the domicile of origin, continues till a new one has been acquired.

Dom'inant, in music, the fifth tone of the diatonic scale, and which assumes the character of a key-note itself when there is a modulation into the first sharp remove. Thus, G is the dominant of the scale of C, and D the dominant of the scale of G.—

Dominant chord, in music, that which is formed by grouping three tones, rising gradually by intervals of a third from the dominant or fifth tone of the scale. It occurs almost invariably immediately before the tonic chord which closes the perfect cadence.

Dom'in'go, SAN, capital of the Dominican Republic (or San Domingo) in the island of Hayti. It lies on the south-east coast at the mouth of the Ozama, and has a commodious port. It is the oldest European city in the New World, having been founded in 1494 by Bartholomew Columbus. Pop. about 16,000.

Dom'inic, SAINT, the founder of the order of the Dominicans, was born in 1170 at Calahorra, in Old Castile. He early distinguished himself by his zeal for the reform of canonical life and by his success as a missionary amongst the Mohanmedans. His attention having been directed to the Albigenses in the south of France, he organized a mission of preachers against heresy in Languedoc. In 1215 he went to Rome to obtain the sanction of Pope Innocent III. to erect the mission into a new order of preaching friars. His request was only partially granted, and it was the succeeding pope, Honorius III., who first recognized the importance of a preaching order, and conferred full privileges on the Dominicans. He also appointed Dominic Master of the Sacred Palace or court preacher to the Vatican, an office which is still held by one of the order. Dominic died at Bologna in 1221, and was canonized in 1234 by Pope Gregory IX. St. Dominic is usually considered the founder of the Inquisition, which is supposed to have originated with his mission to the Albigenses; but his claim is denied, on the ground that two Cistercian monks were appointed inquisitors in 1198.

Dominica (dom-i-nē'kà), a British West India island, so named because discovered by Columbus on a Sunday (Sp. *dominica*), a member of the united colony of the Leeward Islands between Martinique and Guadeloupe. It is about 29 miles in length, north to south, and 12 miles in breadth east to west; area, 186,436 acres. It is rugged and mountainous, but it contains many fertile valleys and is well watered. The shores are but little indented, and are entirely without harbours; but on the west side there are several good anchorages and bays. The principal exports consist of sugar, molasses, cocoa, and lime-juice. The

Imports and exports amount each to about £50,000 annually. Dominica was ceded by France to Great Britain in 1763. Roseau is the capital. Pop. 28,211 (including about 300 aboriginal Caribs).

Dominical Letter, in chronology, properly called Sunday letter, one of the seven letters of the alphabet, A B C D E F G, used in almanacs, ephemerides, &c., to mark the first seven days of the year and all consecutive sets of seven days to the end of the year, so that the letter for Sunday will always be the same. If the number of days in the year were divisible by seven without remainder, then the year would constantly begin with the same day of the week; but as it is the year begins and ends on the same day, and therefore the next year will begin on the day following, and on leap years two days following, so that the same series is not repeated till after four times seven or twenty-eight years.

Dominican Republic, or SAN DOMINGO, a republic occupying the eastern portion of the island of Hayti; area, 20,596 sq. miles. It is fertile and exports mahogany, sugar, tobacco, cocoa, &c., but its resources are as yet but little developed. It formerly belonged to Spain, and is the oldest colonial settlement in America. Its inhabitants are chiefly negroes and mulattoes. Capital, San Domingo. Pop. estimated at 504,000. See *Hayti*.

Dominicans, called also *predicants*, or *preaching friars* (*prædicatores*), derived their name from their founder, St. Dominic. At their origin (1216, at Toulouse) they were governed by the rule of St. Augustine, perpetual silence, poverty, and fasting being enjoined upon them; and the principal object of their institution was to preach against heretics. Their distinctive dress consists of a white habit and scapular with a large black mantle, and hence they have been commonly known as *Black Friars*. They were almost from the first a mendicant order. They spread rapidly not only in Europe, but in Asia, Africa, and America. In England there were fifty-eight Dominican houses at the dissolution of the monasteries, and the Blackfriars locality in London took its name from one of their establishments. They produced some famous scholars, such as Albertus Magnus and Thomas Aquinas, and became formidable as managers of the Inquisition, which was committed exclusively to them in Spain, Portugal, and Italy. In 1425 they obtained permission to receive

donations, and ceased to belong to the mendicant orders, paying more attention to politics and theological science. With the Franciscans, their great rivals, they divided the honour of ruling in church and state



Dominican or Black Friar

till the 16th century, when the Jesuits gradually superseded them in the schools and courts. They obtained new importance in 1620 by being appointed to the censorship of books for the church. Amongst notable Dominicans we may mention Savonarola, Las Casas, and Lacordaire. There are still establishments of the Dominicans both in England and Ireland.

Dominium, a term in the Roman law used to signify full ownership of a thing.

Domino, formerly a dress worn by priests in the winter, which, reaching no lower than the shoulders, served to protect the face and head from the weather. At present it is a masquerade dress worn by gentlemen and ladies, consisting of a long silk mantle with wide sleeves and a masquing hood. The name is also given to a half-mask formerly worn on the face by ladies when travelling or at masquerades.

Dominoes, a game played with small flat rectangular pieces of ivory, about twice as long as they are broad. They are marked with spots varying in number. When one player leads by laying down a domino, the next must follow by placing alongside of it another which has the same number of spots on one of its sides. Thus if the first player lays down 6-4, the second may reply with 4-8, or 6-7, &c.; in the former case he must turn in the 4, placing it beside the 4 of the

first domino, so that the numbers remaining out will be 6-8; in the latter case he must turn in the 6 to the 6 in like manner, leaving 4-7, to which his opponent must now respond. The player who cannot follow suit loses his turn, and the object of the game is to get rid of all the dominoes in hand, or to hold fewer spots than your opponent when the game is exhausted by neither being able to play.

Domitian, or in full TITUS FLAVIUS DOMITIANUS AUGUSTUS, Roman emperor, son of Vespasian, and brother of Titus, was born A.D. 51, and in 81 succeeded to the throne. At first he ruled with a show of moderation and justice, but soon returned



Domitian.

to the cruelty and excesses for which his youth had been notorious. He was as vain as he was cruel, and after an ineffective expedition against the Catti, carried a multitude of his slaves, dressed like Germans, in triumph to the city. He executed great numbers of the chief citizens, and assumed the titles of Lord and God. He established the most stringent laws against high treason, which enabled almost anything to be construed into this crime. At length a conspiracy, in which his wife Domitia took part, was formed against him, and he was assassinated in his bed-room A.D. 96.

Domo, or DOMO D'OSSÖLA, a town of North Italy, province of Novara, in the centre of a plain on the great Simplon road. Pop. 3577.

Domremy la Pucelle (don-ré-mi là pü-säl), the birth-place of Joan of Arc, a small French village, department of the Vosges, 7 miles N. of Neufchâteau. The house is still shown here in which the heroine was born, and in the neighbourhood is the monument erected to her memory.

Don (ancient, *Tanaïs*), a river of Russia,

which issues from Lake Ivan-Ozero, in the government of Tula; and flows s.e. through governments Riazan, Tambov, Voronej, and Don Cossacks, to within 37 miles of the Volga, where it turns abruptly s.w. for 236 miles, and falls into the Sea of Azof; whole course nearly 900 miles. The chief tributaries are: right bank, the Donetz and Voronej; left, the Khoper and Manitsch. Although not admitting vessels of much draught, the Don carries a large traffic especially during the spring-floods, and a canal connects it with the Volga system of navigation. It has also very extensive and productive fisheries.

Don, a river, Scotland, county Aberdeen, rising near the Banffshire border. It flows tortuously E. through the whole breadth of Aberdeenshire, and falls into the North Sea a little to the north of Aberdeen, after a total course of 82 miles. Its salmon fisheries are of considerable value.—Also, a river of Yorkshire, England, which rises near Cheshire, and joins the Ouse after a course of about 70 miles. It is navigable for small craft to Sheffield.

Don (Latin, *dominus*, a lord or master), a Spanish title of honour, originally given only to the highest nobility, afterwards to all the nobles, and finally used indiscriminately as a title of courtesy. It corresponds with the Portuguese Dom. During the Spanish occupation it was introduced and became naturalized in some parts of Italy, and was particularly applied to the priests.

Donaghadee (don-a-ha-dē'), a seaport and market town, Ireland, county Down, on the Irish Channel, 16 miles east by north of Belfast. Pop. 1861.

Donaldson, JOHN WILLIAM, D.D., a distinguished English scholar, was born in London in 1811. He studied at London University and at Trinity College, Cambridge, where he was elected a fellow. His first work was *The Theatre of the Greeks*, a work showing much erudition. In 1839 he published *The New Cratylus*, which was amongst the earliest attempts to bring the philological literature of the Continent within the reach of the English student. In 1844 appeared the first edition of *Varronianus*, a work on Latin similar in scope to the *Cratylus*. Amongst his other writings are grammars of the Hebrew, Greek, and Latin languages. He died in 1861.

Donatello (properly, *Donato di Betto Bardì*), one of the revivers of the art of sculpture in Italy, was born at Florence be-

tween 1382 and 1387. His first great works in marble were statues of St. Peter and St. Mark, in the church of St. Michael in his native town, in an outside niche of which is also his famous statue of St. George. Along with his friend Brunelleschi he made a journey to Rome to study its art treasures. On his return he executed for his patrons, Cosimo and Lorenzo de' Medici, a marble monument to their father and mother, which is of high merit. Statues of St. John, of Judith, David, and St. Cecilia are amongst his leading works. He died at Florence in 1466.

Donatio mortis causa is a gift of personal property made in prospect of the death of the donor and consummated by that event.

Dona'ti's Comet, so called from the Italian astronomer Donati, who first observed it in June 1858. Next to the comet of 1811 it is the most brilliant that has appeared this century. It was nearest the earth on the 10th October, 1858.

Don'atists, one of a body of African schismatics of the 4th century, so named from their founder Donatus, Bishop of Casa Nigra in Numidia, who taught that though Christ was of the same substance with the Father yet that he was less than the Father, that the Catholic Church was not infallible, but had erred in his time and become practically extinct, and that he was to be the restorer of it. All joining the sect required to be rebaptized, baptism by the impure church being invalid.

Dona'tus, ÆLIUS, a Roman grammarian and commentator, born A.D. 333. He was the preceptor of St. Jerome, wrote notes on Virgil and Terence, and a grammar of the Latin language so universally used in the middle ages that 'Donat' became a common term for grammar or primer of instruction.

Donau (don'ou). See *Danube*.

Donaueschingen (don'ou-esh-ing-en), a town of Baden, Germany, 29 miles east by south of Freiburg. It contains the Prince of Fürstenberg's palace, in the garden of which a basin of clear sparkling water claims to be the true source of the Danube. Pop. 3522.

Donauwörth (don'ou-veurt), a town, Bavaria, at the confluence of the Wörnitz and Danube. It was formerly a free imperial town, and was stormed by the Swedes under Gustavus Adolphus in the Thirty Years' war, 1632. Pop. 3857.

Donax (*Arundo donax*), a species of grass or reed inhabiting the southern parts of

Europe; it grows to a great height and is used for fishing-rods, &c.

Don Beni'to, a town, Spain, province of Badajoz. It has manufactures of woollens, and a trade in cattle, grain, &c. Pop. 14,610.

Don'caster, a municipal borough and market town, England, West Riding of Yorkshire, on the river Don, well built, with straight, broad streets. The parish church with its tower 170 ft. high, Christ Church, the town-hall, the theatre, are amongst the chief public buildings. It has manufactures of ropes, canvas, machinery, &c. It has been long celebrated for its annual races, now held in the middle of September. Doncaster was originally a Roman station on the line of the old Roman Watling Street. Pop. 1890, 25,938.

Dondrah Head, the southern extremity of the island of Ceylon. It was the site of the Singhalese capital during part of the 7th century, numerous remains of which are still to be found.

Don'egal, a maritime county, Ireland, province of Ulster, bounded N. and W. by the Atlantic Ocean; area, 1,197,154 acres, of which about a fifth is under crops. The coast is indented with numerous bays; the most remarkable being Lough Swilly. It is the most mountainous county in Ireland, but has some fine fertile valleys. Mount Errigal, the loftiest summit, is about 2460 ft. high. The streams and lakes are small, but numerous and abounding in fish. The climate is moist, the subsoil chiefly granite, mica-slate, and limestone, and the principal crops oats, potatoes, and flax. Spade husbandry is much employed, and agriculture generally is in a very backward state. The manufactures are limited, and consist chiefly of linen cloth, woollen stockings, and worked muslin. The fisheries are extensive and valuable, and form the chief employment of the inhabitants of the coast and islands. Grain, butter, and eggs are exported. The minerals include marble, lead, copper, &c., but are not wrought to advantage. For parliamentary purposes Donegal is divided into four divisions, each of which returns a member. Pop. 185,211. — **DONEGAL**, the county town, is a small seaport on the bay of the same name, at the mouth of the river Esk. Pop. 1416.

Donetz', a Russian river which rises in government Kursk, flows south and east, forming the boundary of several governments, and, after a course of 400 miles, joins the Don.

Don'gola, a district of Upper Nubia, extending on both sides of the Nile from about lat. 18° to lat. 20° N. It formerly belonged to Egypt and was the seat of a pasha, but since the evacuation of all the country south of Wady Halfa in 1886 by the Egyptian government has been left in an unsettled state. Its chief products are dates, cotton, indigo, and maize. The population is a mixture of Arabs and indigenous Nubians. Its chief town is Dongola or *El Ordeh*, on the left bank of the Nile. Pop. 6000.

Doni, a clumsy kind of boat used on the coast of Coromandel and Ceylon; sometimes decked, and occasionally furnished with an outrigger. The donis are about 70 ft. long, 20 ft. broad, and 12 ft. deep, have one mast and a lug-sail, and are navigated in fine weather only.

Donizet'ti, GAETANO, Italian composer, born in 1798, at Bergamo. He studied music at Bologna under the distinguished Abbé Mattei. His first opera, *Enrico di Borgogna*, was represented at Venice in 1818. In 1822 his *Zoraïde di Granata* gained him the honour of being crowned on the Capitol. In 1830 appeared his *Anna Bolena*, which first, along with *Lucrezia Borgia* and *Lucia di Lammermoor*—the latter his masterpiece—acquired for him a European fame. In 1835 Donizetti was appointed professor of counterpoint at the Royal College of Naples, but removed in 1840 to Paris, bringing with him three new operas, *Les Martyrs*, *La Favorita*, and *La Filledu Régiment*, of which the last two are amongst his most popular productions. Of his other operas none except *Linda di Chamouni* (1842) and *Don Pasquale* (1843) achieved any special triumph. He died 8th April, 1848. He had written as many as sixty-four operas.

Donjon, the principal tower of a castle, situated in the innermost court or bailey, which the garrison could make the last line of defence. Its lower part was commonly used as a prison. See *Castle*.

Don Juan (Sp. pron. *hū-án'*), the hero of a Spanish legend which seems to have had some historical basis in the history of a member of the noble family of Tenorio at Seville. According to the legend Don Juan was a libertine of the most reckless character. An attempt to seduce the daughter of a governor of Seville brought the indignant father and the profligate don into deadly conflict, in which the former was slain. Don Juan afterwards, in a spirit of wild mockery, goes to the grave of the murdered man and

invites the statue of him erected there to a revel. To the terror of Don Juan the 'stony guest' actually appears at the table to bear him away to the infernal world.

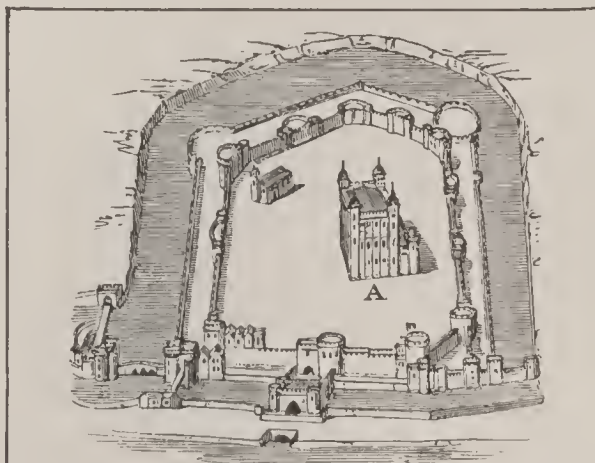

Tower of London, time of Henry VIII. A, The Donjon.

The legend has furnished the subject for many dramas and operas. The most famous of the latter is Mozart's *Don Giovanni*, which has made the story familiar to everybody. Amongst the former are *Burlador de Sevilla* by Tellez, *Don Juan ou Le Festin de Pierre*, by Molière, and *The Libertine* by Shadwell. The *Don Juan* of Byron bears no relation to the old story but in name and in the libertine character of the hero.

Donkey-engine, a small engine used in various operations where no great power is required. Thus a donkey-engine is often stationed on the deck of a ship to work a crane for loading and unloading.

Donne, JOHN, D.D., a celebrated poet and divine, was the son of a merchant of London, in which city he was born in 1573. He studied both at Oxford and Cambridge. In his nineteenth year he abjured the Catholic religion, and became secretary to the Lord-chancellor Ellesmere, but finally lost his office by a clandestine marriage with his patron's niece. The young couple were in consequence reduced to great distress, till his father-in-law relented so far as to give his daughter a moderate portion. By the desire of King James Donne took orders, and, settling in London, was made preacher of Lincoln's Inn. In 1621 he was appointed Dean of St. Paul's. He was chosen prolocutor to the convocation in 1623-24. He died in March, 1631, and was interred in St. Paul's. As a poet, and the precursor of Cowley, Donne may be deemed the founder of what Dr. Johnson calls the *metaphysical* class of poets. Abounding in thought this school generally neglected ver-

sification, and that of Dr. Donne was peculiarly harsh and unmusical. His style is quaint and pedantic; but he displays sound learning, deep thinking, and originality of manner. Besides the works already mentioned, he wrote Letters, Sermons, Essays on Divinity, and other pieces.

Donnybrook, a village, Ireland, now mostly in the parliamentary borough of Dublin. Its famous fair, which seldom passed off without riot and bloodshed, was abolished in 1855.

Don Quixote (Sp. pron. *kē-hō'tā*), the title of a famous romance by Cervantes. (See *Cervantes*.) The name of the hero, Don Quixote, is used as a synonym for foolish knight-errantry or extravagant generosity.

Doo, GEORGE THOMAS, English engraver, born 1800, died 1886. He became early known as an excellent artist, and was appointed historical engraver to William IV. and subsequently to Queen Victoria. He was elected an associate of the Royal Academy in 1856, and next year Academician. Among his important plates were Knox preaching before the Lords of the Covenant (Wilkie), Mercy appealing for the Vanquished (Etty), Lord Eldon and other portraits (Lawrence), Pilgrims in Sight of Rome (Eastlake), The Messiah (Raphael), Ecce Homo (Correggio), Raising of Lazarus (Del Piombo), &c. He also painted portraits in oil.

Doom Palm. See *Doom Palm*.

Doomsday Book. See *Domesday Book*.

Doomster, a name formerly given in Scotland to the public executioner. See *Deemster*.

Doon, a river in Ayrshire, Scotland, which after a course of 30 miles falls into the Firth of Clyde. It is celebrated in the poems of Burns.

Dor, DORR, the black-beetle, *Geotrūpes stercorarius*, one of the most common of beetles, of a stout form, less than 1 inch long, black with metallic reflections. It may often be heard droning through the air towards the close of the summer twilight. See *Dung Beetle*.

Dora, the name of two rivers in Northern Italy, both tributaries of the Po. The D. BALTEA rises on the southern slopes of the Mont Blanc group, and falls, after a course of about 100 miles, into the Po below Chivasso; the D. RIPARIA, about 75 miles long, rises in the Cottian Alps, and joins the Po below Turin.

Dora D'Istria. See *Ghika (Helena)*.

Dorak', a town, Persia, province Khuzistan, 300 miles s.e. Bagdad. It has a considerable commerce by a canal which connects the Dorak with the Karun. Pop. 6000.

Do'ran, JOHN, Ph.D., English writer, born 1807, died 1878. He began writing when a mere youth, and produced a great number of books, among them being *Lives of the Queens of England of the House of Hanover*, *Monarchs retired from Business*, *History of Court Fools*, *the Princes of Wales*, *Their Majesties' Servants* (a history of the English stage from Betterton to Kean), *A Lady of the Last Century* (Mrs. Montague), London in *Jacobite Times*.

Dorcas Society (from *Dorcas* mentioned in Acts ix.), an association generally composed of ladies for supplying clothes to the poor. Frequently the members of the society meet at stated times and work in common. Partial payment is generally required from all recipients except the very poor.

Dorchester, a municipal borough of England, chief town of Dorsetshire, 118 miles s.w. of London. There are large cavalry and infantry barracks a little to the west of the town. The trade consists chiefly in agricultural produce. Dorchester was an important Roman station (Durnovaria), and many interesting Roman remains are still to be found in the vicinity. It was a parliamentary borough till 1885, when it was merged in the county. Pop. 7567.

Dordogne (dor-dony), a department of France, which includes the greater part of the ancient province of Périgord, and small portions of Limousin, Angoumois, and Saintonge. Area, 3544 square miles, of which about a third is fit for the plough. The chief minerals are iron, which is abundant, slate, limestone, marble, and other stone. Mining, iron manufacture, &c., are carried on to a considerable extent, and there are a number of vineyards. The climate is mild but somewhat changeable. Pop. 478,471.—The river DORDOGNE, principal river of the department, rises on the flanks of the Puy-de-Sancy, flows w.s.w., and after a course of 290 miles unites with the Garonne in forming the Gironde.

Dordrecht (dor'dreht). See *Dort*.

Doré (dō-rā), PAUL GUSTAVE, a prolific French draftsman and painter, born at Strasbourg Jan. 6, 1833. He studied at Paris, contributing, when only sixteen years of age, comic sketches to the *Journal pour Rire*. He distinguished himself greatly as

an illustrator of books. His illustrations of Rabelais, of Perrault's Tales, Sue's Wandering Jew, Dante's Divina Commedia, and Cervantes' Don Quixote, displayed great fertility of invention, and the fine fantasy of his landscapes and the dramatic effectiveness of his groups acquired for him a European reputation. His illustrations of the Bible, of Ariosto's Orlando Furioso, and Milton's Paradise Lost are also of high excellence. As a painter he has grandeur of conception and a bold expressive style. Amongst his chief works are Christ leaving the Prætorium, Paolo and Francesca di Rimini, The Flight into Egypt, Mont Blanc, &c. In later years Doré also won fame as a sculptor. He died 23d June, 1883.

Doree, a fish. See *Dory*.

Dore'ma, a genus of plants, nat. order Umbelliferæ. *D. ammoniacum*, a Persian species, yields the ammoniacum of commerce, a milky juice that exudes from punctures on the stem and dries in little 'tears.'

Doria, one of the most powerful families of Genoa, became distinguished about the beginning of the twelfth century, and shared with three other leading families, the Fieschi, Grimaldi, and Spinola, the early government of the republic. Amongst the older heroes of this family are OBERTO DORIA, who in 1284 commanded the Genoese fleet which at Meloria annihilated the power of Pisa; LAMBA DORIA, who in 1298 defeated the Venetian Dandolo at the naval battle of Curzola; PAGANINO DORIA, who in the middle of the fourteenth century distinguished himself by great victories over the Venetians. But the greatest name of the Dorias is that of ANDREA, born at Oneglia in 1466, of a younger branch of the family. After serving some time as a condottiere with the princes of Southern Italy, he was entrusted by the Genoese with the reconstruction of their fleet. Disagreement with the Genoese factions drove him to take service with Francis I. of France, in which he highly distinguished himself, and in 1527 he took Genoa in name of the French king. But being displeased with the projects of Francis for reducing Genoa to a place of secondary importance he went over to the service of Charles V. (1529), carrying with him the whole influence and resources of Genoa. He re-established order in Genoa, reorganized the government, and although refusing the title of doge practically controlled its affairs to the end of his life. As imperial admiral

he performed many services for Charles, clearing the seas of Moorish pirates and assisting the emperor in his expeditions to Tunis and Algiers. In 1547 his authority was threatened by the conspiracy of Fieschi, and he narrowly escaped assassination in the tumult. He died in 1560.

Dorians, one of the four great branches of the Greek nation who migrated from Thessaly southwards, settling for a time in the mountainous district of Doris in Northern Greece and finally in Peloponnesus. Their migration to the latter was said to have taken place in B.C. 1104; and as among their leaders were certain descendants of Hercules (or Herakles), it was known as the return of the Heraclidæ. The Dorians ruled in Sparta with great renown as a strong and warlike people, though less cultivated than the other Greeks in arts and letters. Their laws were severe and rigid, as typified in the codes of the great Doric legislators Minos and Lycurgus. (See *Sparta*.)—The *Doric dialect* was characterized by its broadness and hardness, yet on account of its venerable and antique style was often used in solemn odes and choruses.

Doric Mood, or DORIC MODE, in music, was of a grave and manly character, adapted both to religious services and war.

Doric Order, in architecture, is the oldest, strongest, and simplest of the three Grecian orders, and the one that is best represented among the remains of ancient Greek architecture. The Doric column is distinguished by its want of a base (in the more ancient examples, at least), by the small number of its flutings, and by its massive proportions, the true Grecian Doric having the height of its pillars six times that of the diameter. The capital was small and simple, and the architrave, frieze, and cornice were rather plain and massive.

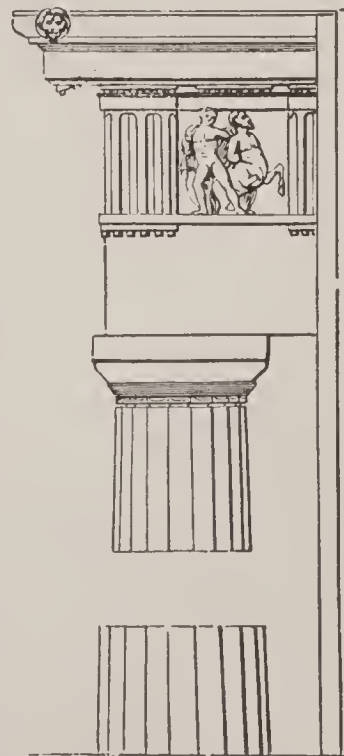

Grecian Doric Order.

Dorigny (do-rē-nyē), the name of several French painters and engravers. MICHAEL, born in 1617, became professor in the Academy at Paris, and died in 1665. LOUIS, son of the preceding, was born in 1654, settled in Italy, and died in 1742. SIR NICHOLAS, brother of Louis, born in 1658 at Paris, was the most celebrated of the three. He spent eight years in engraving the famous cartoons of Raphael at Hampton Court, and was knighted by George I. He died in 1746.

Doris, anciently a small and mountainous region of Northern Greece, at one time the abode of the Dorians (which see).

Doris. See *Sea-lemon*.

Dorking, a town of England, county of Surrey, 22 miles s.s.w. of London, largely consisting of villa residences. Large numbers of fowls, known as *Dorkings*, of an excellent breed, having five claws on the foot, are reared here, and sent to the London markets. Pop. 6328.

Dormant State, a state of torpidity in which certain animals pass a portion of the year. In cold and temperate climates this period of long sleep takes place during the winter months, and is properly called *hibernation*. It commences when the food of the animal begins to get scarce, continues for a longer or shorter period, and is deeper or lighter according to the habits and constitution of the animal. Bats, bears, some animals of the rodent order, such as the porcupine, the dormouse, the squirrel, &c., all the animals belonging to the classes of Amphibia and Reptilia, such as tortoises, lizards, snakes, frogs, &c., and many species of molluscs and insects, hibernate more or less completely, retiring to suitable places of concealment—the bat to dark caves, the hedgehog to fern-brakes, snakes to holes in trees, &c. During hibernation there is a great decrease of heat in the bodies of the animals, the temperature sometimes sinking to 40° or even 20° Fahr., or in general to a point a little above that of the surrounding atmosphere. The respiration as well as the pulsation of the heart is exceedingly slow, and the irritability of the animal often so low that in some cases it can be awakened only by strong electric shocks. With frogs and amphibious reptiles the dormant state is very common, and if the temperature is kept low by artificial means they may remain dormant for years. The term *æstivation* has been used to describe a similar condition into which certain animals, such as serpents and crocodiles, in tropical

countries pass during the hottest months of the year.

Dormer Windows are windows inserted in the inclined plane of a sloping roof, on a frame rising vertically above the rafters. They are named dormer windows because they are found chiefly in attic bed-rooms (Fr. *dormir*, to sleep).

Dormouse (*Myoxus*), a genus of mammiferous quadrupeds, of the order Rodentia. These little animals, which appear to be intermediate between the squirrels and the mice, inhabit temperate and warm countries, and subsist entirely on vegetable food. Their pace is a kind of leap, but they have not the activity of squirrels. Whilst feeding they sit upright and carry the food to their mouth with their paws. The dormice pass the winter in a lethargic or torpid state, reviving only for a short time on a warm sunny day, when they take a little of their hoarded stores and then relapse into the dormant state. They bring forth three or four at a birth.

Dorn'birn, a manufacturing town of Austria in Tyrol, about 6 miles from the Lake of Constance. Pop. 9307.

Dornick, a kind of stout figured linen fabric used for table-cloths, and generally chequered.

Dornoch (-noh), a seaport and parliamentary and royal burgh of Scotland, county of Sutherland, at the entrance of the Dornoch Firth, the seat of the extinct bishopric of Caithness. It is one of the Wick district of parliamentary burghs. Pop. 497.—The FIRTH runs inland for about 16 miles between Ross-shire and Sutherlandshire.

Dor'ogobush, a town of Russia, government of and 55 miles E.N.E. of Smolensk, on the Dnieper. Pop. 7865.

Dor'ohoi, a town of Roumania in N.W. Moldavia, near the Austrian frontier. Pop. 15,000.

Dorp, a town in the Rhine province of Prussia, on the Wupper. It has important manufactures of cutlery, paper, &c. Pop. 13,285.

Dor'pat, a town, Russia, government Livonia, on the Embach, about 135 miles N.E. Riga. Dorpat is chiefly remarkable for its university and other educational establishments. It is an ancient town, and was once a member of the Hanseatic Union. In 1704 it passed definitively into the hands of Russia. The vernacular language is Esthonian, but that of the learned is German. Pop. 30,643.

D'Orsay, ALFRED, COUNT, a dilettante artist and man of fashion, born at Paris 1798, died 1852. When a young man he visited England, and became acquainted with Byron and other literary and fashionable celebrities. He married a daughter of the Earl of Blessington, but after the earl's death a separation took place, and D'Orsay became an inmate of Gore House, which the Countess of Blessington had made the centre of a famous literary coterie. A zealous Bonapartist, he followed Prince Louis Napoleon to Paris in 1849, whose favour he enjoyed till his death.

Dorse (*Morrhua Callarius*), a fish of the cod genus, called also Baltic cod.

Dorset, DORSETSHIRE, a maritime county in the south of England, having on the south the English Channel; area, 627,265 acres, over 490,000 being under crop. The general surface of the county is undulating; its principal elevations being chalk hills known as the North and South Downs, upon which immense flocks of sheep are pastured. On the s., on the borders of Hampshire and along part of the sea-coast, is a heathy common. A great part of the county is in grass, and dairy husbandry is extensively carried on. Neither coal nor ores of any kind are found, but the quarries yield the well-known Portland stone. Pipe-clay, plastic clay, and potter's clay also abound. The principal manufactures are those of flax, canvas, duck, &c., also silk and woollens. The fish frequenting the coast are of various kinds, but mackerel is the most abundant. Near the mouth of Poole harbour is a prolific oyster bank. The principal rivers are the Stour, the Frome, and the Piddle. The county has four parliamentary divisions, with a member for each. Dorchester is the county town. Other towns are Bridport, Poole, and Weymouth. Pop. 194,487.

Dorset, EARLS OF. See *Sackville*.

Dorste'nia, a genus of plants, nat. order Urticaceæ or nettles, found in tropical America. They have their naked flowers buried in a flat, fleshy, somewhat concave receptacle. *D. Contrayerva* and other species have a stimulant and tonic rhizome, which is used medicinally under the name of *contrayerva* (which see).

Dort, or DORDRECHT, a town, Holland, province South Holland, 14 miles s.e. Rotterdam, on the Merwede, an arm or part of the Maas, and on an island separated from the mainland by an inundation in 1421. It is an old town, with a fine Gothic church

(Groote Kerk, 'Great Church'), a good town-house, museum, &c. It was formerly of more importance than now, but it still carries on an extensive trade, being not only near the sea, but by the Rhine, the Maas, and other water communications, connected with an immense extent of inland territory. Pop. 1892, 33,508.

Dort, SYNOD OF, an assembly of Protestant divines convoked at Dort in 1618-19. Besides the Dutch and Walloon divines, it included representatives from England, Scotland, Switzerland, and part of Germany, in all about 62 native and 24 foreign deputies. The synod was convoked principally for the sake of crushing the Arminian party, and extreme measures were taken to prevent that party being represented in the assembly or having a free voice there. The result was the condemnation of the Arminians and the dogmatic establishment of Calvinism in the Reformed church. The synod also set on foot the Dutch translation of the Bible known as the Dort Bible.

Dort'mund, a city of Prussia, province of Westphalia, situated on the Ems, 47 miles n.n.e. of Cologne. It has rapidly increased in recent years, its prosperity being due to its becoming the centre of several important railway systems, to the opening of extensive coal-mines in the vicinity, and to the active manufactures of iron, steel, machinery, railway plant, &c. There are also a number of breweries, potteries, tobacco factories, chemical works, &c. It was once a free imperial Hanseatic town, and the seat of the chief tribunal of the Vehme. Pop. 89,663.

Dory, or JOHN DORY (*Zeus faber*), a fish belonging to the mackerel family, celebrated for the delicacy of its flesh. It seldom exceeds 18 inches in length, and is yellowish-green in colour with a blackish spot on each side, which, according to an old

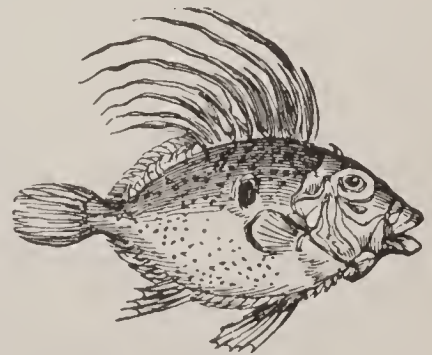

Dory (*Zeus faber*).

superstition, is the mark of St. Peter's forefinger and thumb. The dory is found on the Atlantic shores of Europe and in the Mediterranean. The name John Dory is supposed to be derived from the French *jaune doré*, golden yellow.

Dosith'eans, an ancient sect among the Samaritans, so called from their founder Dositheus, who was a contemporary and associate of Simon Magus, and lived in the first century of the Christian era. They rejected the authority of the prophets, believed in the divine inspiration of their founder, and had many superstitious practices.

Dosso Dossi, Italian painter of the Ferrara school; born 1479, died 1542. He was much honoured by Duke Alfonso of Ferrara, and immortalized by Ariosto (whose portrait he executed in a masterly manner) in his Orlando. Modena and Ferrara possess most of his works.

Dost Mohammed Khan, born about 1790, a successful usurper who obtained possession of the throne of Afghanistan after the flight of Mahmud Shah in 1818. He ruled with very great ability, and although driven from his throne by a British army was ultimately restored, and latterly became a steady supporter of British power in the East. See *Afghanistan*.

Dostoieff'sky, FEODOR MICHAÏLOVITCH, a Russian novelist, born 1818, died 1881. After serving as an officer of engineers he devoted himself to literature, but becoming connected with communistic schemes he was banished to the mines of Siberia, from which he returned in 1856 to resume his literary activity. His first novel, *Poor People*, came out in 1846. Among his works that have appeared in English are *Crime and Punishment*; *Injury and Insult*; *The Friend of the Family*; *The Gambler*; *The Idiot*; *Prison Life in Siberia*.

Dotis, or TOTIS, a market town, Hungary, county Komorn, 37 miles w.n.w. Budapest. It has a castle of the Esterhazy family, and manufactures of woollens and stoneware, &c. Pop. 10,291.

Dot'terel (*Charadrius morinellus*), a species of plover which breeds in the north of Europe, and returns to the south for the winter. In Scotland it appears in April and leaves in August, the young being hatched in July. It is found all over Europe and Northern Asia. Several species are represented in the United States, including the Golden plover, the Kill-deer, and Piping-plover.

Douai (dō-ā), or DOUAY, a town, France, department Nord, on the Scarpe, 18 miles south of Lille. It is one of the oldest towns in France, of which it became part by the Treaty of Utrecht. It is strongly fortified,

has a fine town-house, several handsome churches, an academy of arts and law, a lyceum, museum and public library, Benedictine college, hospital, &c.; a cannon foundry, linen manufactories, machine-works, tanneries, &c. There was long here a college for British Roman Catholic priests, the most celebrated of its kind. Pop. 30,030.

Douai Bible, the English translation of the Bible used among English-speaking R. Catholics, and executed by divines connected with the English College at Douai. The New Testament was published in 1582 at Rheims, the Old in 1609-10 at Douai, the translation being based on the Vulgate. Various revisions have since materially altered it.

Douarnenez (dū-ār-nè-nā), a seaport, France, Finistère, on a beautiful bay of the same name, 13 miles north-west of Quimper. It depends chiefly on the sardine fishery. Pop. 10,985.

Double-bass. See *Contra-basso*.

Double-eagle, an American gold coin of the value of 20 dols. or £4 sterling, so called because double the value of the coin called the eagle.

Double-entry. See *Book-keeping*.

Double-first, in Oxford University, one who gains the highest honours, after examination, both in classics and mathematics.

Double-flowering is the development, often by cultivation, of the stamens and pistils of flowers into petals, by which the beauty of the flower is enhanced and its reproductive powers sacrificed.

Double-insurance, the effecting of two insurances upon the same goods. In marine insurance it is lawful for a shipper to insure his goods twice, but only to give an additional security in the event of the failure of the first underwriters. In the event of a loss it is ultimately divided among the underwriters in the ratio of the risks they have taken.

Double-standard of Monetary Value. See *Currency, Bi-metallism*.

Double-stars, or BINARY STARS, stars which are so close together that they appear as one to the naked eye, but are seen to be double when viewed through a telescope. One of these stars may revolve about the other, or both may revolve round a common centre. See *Stars*.

Doublet, a close-fitting garment, covering the body from the neck to a little below the waist. It was introduced from France into England in the 14th century,

and was worn by both sexes and all ranks until the time of Charles II., when it was superseded by the vest and waistcoat. The



1, Doublet, time of Edward IV. *2, 3, Doublets, time of Elizabeth. 4, Doublet, time of Charles I.

garment got its name from being originally lined or wadded for defence.

Doublet, in lapidary work, a counterfeit stone composed of two pieces of crystal, with a colour between them, so that they have the same appearance as if the whole substance of the crystal were coloured.

Double-vault, in arch. one vault built over another so that a space is left between the two. It is used in domes or vaulted roofs when the external and internal arrangements require vaults differing in size or shape, the outer and upper vault being made to harmonize with the exterior of the building, the inner or lower with the interior. See *Dome*.

Doubloon', a coin of Spain and of the Spanish American states, originally double the value of the pistole. The doubloon of Spain is of 100 reals and equivalent to about \$5.00. The doubloon of Chili is worth about \$4.68; the doubloon of Mexico, \$16.16.

Doubs (dö), a department of France, having Switzerland on its eastern frontier. Its surface is traversed by four chains of the Jura. The temperature is variable, and the climate somewhat rigorous. About a third of the land is arable, but much the

greater part is covered with forests. **Maize**, potatoes, hemp, flax, are the principal crops. Much dairy produce is made into Gruyère cheese. The minerals include iron, lead, and marble. Pop. 303,081.—The river Doubs rises in the department to which it gives its name, flows first N.E., then N.W. till it joins the Saône at Verdun-sur-Saône; length, 250 miles.

Douche (dösh), a jet or current of water or vapour directed upon some part of the body; employed in bathing establishments. When water is applied it is called the *liquid douche*, and when a current of vapour the *vapour douche*.

Douglas (dug'las), capital of the Isle of Man, is situated on the south-east coast, on a beautiful semicircular bay. It is frequented by immense numbers of visitors during the summer. Among the objects of interest are the House of Keys, the custom-house, the extensive breakwater, the promenade, &c. Pop. 15,500.

Douglas (dug'las), a family distinguished in the annals of Scotland. Their origin is unknown. They were already territorial magnates at the time when Bruce and Baliol were competitors for the crown. As their estates lay on the borders they early became guardians of the kingdom against the encroachments of the English, and acquired in this way power, habits, and experience which frequently made them formidable to the crown. We notice in chronological succession the most distinguished members of the family. **JAMES**, son of the William Douglas who had been a companion of Wallace, and is commonly known as the Good Sir James, early joined Bruce, and was one of his chief supporters throughout his career, and one of the most distinguished leaders at the battle of Bannockburn. He fell in battle with the Moors while on his way to the Holy Land with the heart of his master, in 1331.—**ARCHIBALD**, youngest brother of Sir James, succeeded to the regency of Scotland in the infancy of David. He was defeated and killed at Halidon Hill by Edward III. in 1333.—**WILLIAM**, son of the preceding, was created first earl in 1357. He recovered Douglasdale from the English, and was frequently engaged in wars with them. He fought at the battle of Poitiers. He died 1384.—**JAMES**, the second earl, who, like his ancestors, was constantly engaged in border warfare, was killed at the battle of Otterburn in 1388. After his death the earldom passed to an illegitimate son of the

DOUGLAS.

Good Sir James, Archibald the Grim, Lord of Galloway.—ARCHIBALD, son of Archibald the Grim and fourth earl, was the Douglas who was defeated and taken prisoner by Percy (Hotspur) at Homildon 14th September, 1402. He was also taken prisoner at Shrewsbury 23d July, 1403, and did not recover his liberty till 1407. He was killed at the battle of Verneuil, in Normandy, in 1427. Charles VII. created him Duke of Touraine, which title descended to his successors.—WILLIAM, sixth earl, born 1422, together with his only brother David was assassinated by Crichton and Livingstone at a banquet to which he had been invited in the name of the king, in Edinburgh Castle, on 24th November, 1440. Jealousy of the great power which the Douglasses had acquired from their possessions in Scotland and France was the cause of this deed.—WILLIAM, the eighth earl, a descendant of the third earl, restored the power of the Douglasses by a marriage with his cousin, heiress of another branch of the family; was appointed lord-lieutenant of the kingdom, and defeated the English at Sark. Latterly having entered into a treasonous league, he was invited by James II. to Stirling and there murdered by the king's own hand, 22d Feb. 1452.—JAMES, the ninth and last earl, brother of the preceding, took up arms with his allies to avenge his death, but was finally driven to England, where he continued an exile for nearly thirty years. Having entered Scotland on a raid in 1484 he was taken prisoner and confined in the abbey of Lindores, where he died in 1488. His estates, which had been forfeited in 1455, were bestowed on the fourth Earl of Angus, the 'Red Douglas,' the representative of a younger branch of the Douglas family, which continued long after to flourish. The fifth Earl of Angus, Archibald Douglas, was the celebrated 'Bell-the-Cat,' one of whose sons was Gawin Douglas the poet. He died in a monastery in 1514. Archibald, the sixth earl, married Queen Margaret, widow of James IV., attained the dignity of regent of the kingdom, and after various vicissitudes of fortune, having at one time been attainted and forced to flee from the kingdom, died about 1560. He left no son, and the title of Earl of Angus passed to his nephew David. James Douglas, brother of David, married the heiress of the Earl of Morton, which title he received on the death of his father-in-law. His nephew, Archibald, eighth Earl

of Angus and Earl of Morton, died childless, and the earldom of Angus then passed to Sir William Douglas of Glenbervie, his cousin, whose son William was raised to the rank of Marquis of Douglas. Archibald, the great-grandson of William, was raised in 1703 to the dignity of Duke of Douglas, but died unmarried in 1761, when the ducal title became extinct, and the marquissate passed to the Duke of Hamilton, the descendant of a younger son of the first marquis. The line of Angus or the Red Douglas is now represented by the houses of Hamilton and Home, who both claim the title of Earl of Angus.

Douglas, DAVID, a Scottish botanist, born in 1798. In 1823, as botanical collector to the Horticultural Society of London, he went to the United States, and in 1824 to California, collecting many rare plants and trees. In 1827 he returned to England, and some years later sailed on another expedition to the Sandwich Islands, where he met his death by an accident in 1834.

Douglas, GAWIN, an early Scottish poet of eminence. He was the son of Archibald, earl of Angus, and was born at Brechin about 1474. He received a liberal education, commenced at home and completed at the University of Paris. On returning to Scotland he took orders in the church, and ultimately became Bishop of Dunkeld. He died of the plague in 1522 in London, where he had been obliged to take refuge on account of political commotions. He translated Virgil's *Æneid* into verse with much spirit and elegance, prefixing original prologues to the different books of the original. This was the first poetical translation into English of any classical author. It was written about 1512, and first published in 1553. He also wrote *The Palace of Honour* and *King Hart*, both allegorical poems.

Douglas, SIR HOWARD, Baronet, K.C.B., a British general, born in 1776, the son of Admiral Sir Charles Douglas. He served in Spain in the Peninsular war, and acquired much reputation by his writings on military subjects, especially by his *Treatise on Naval Gunnery* (1819). From 1823 to 1829 he was governor of New Brunswick, and from 1835 to 1840 Lord High-commissioner of the Ionian Islands. He attained the rank of general in 1851, and died in November, 1861.

Douglas, STEPHEN ARNOLD, American statesman, born in Vermont 1813, died 1861. Having gone to Jacksonville, Ill., he became

an attorney, was appointed attorney-general for the state, and in 1843 was elected a member of the U.S. House of Representatives. In 1847 he was member of the Senate, and by re-election was a member of this body till his death. He was especially prominent in connection with the question as to the extension of slavery into new states and territories, which he maintained was a matter to be settled by the people of the respective states or territories, and not by Congress. He was a presidential candidate in 1860, when Lincoln was elected.

Douglass, FREDERICK, American lecturer and journalist, was the son of a negro slave, and was born at Tuckahoe in Maryland about 1817. Although his father was a white man, he was, according to the law, reared as a slave. In 1832 he was purchased by a Baltimore-ship-builder, but made his escape in 1838. As he had taught himself to read and write, and showed talent as an orator, he was employed by the Anti-slavery Society as one of their lecturers. In 1845 he published his autobiography, and afterwards made a successful lecturing tour in England. In 1870 he started a journal entitled *The New National Era*; in 1871 he was appointed secretary of the commission to Santo Domingo; in 1872, presidential elector; in 1877 marshal for the district of Columbia; commissioner of deeds for that district, 1881-86; and U. S. Minister to Hayti in 1890. He died in 1895.

Doum Palm (dōm), a palm-tree, *Hyphæne thebaica*. It is remarkable, like the other species of the genus, for having a repeatedly-branched stem. Each branch terminates in a tuft of large fan-shaped leaves. The fruit is about the size of an apple; it has a fibrous mealy rind, which tastes like gingerbread (whence the name *gingerbread tree* sometimes applied to this palm), and is eaten by the poorer inhabitants of Upper Egypt, where it grows. An infusion of the rind is also used as a cooling beverage in fevers. The seed is horny, and is made into small ornaments. Ropes are made of the fibres of the leaf-stalks.

Douro (dō'rō), or DUERO, one of the largest rivers of the Spanish Peninsula, which, flowing west, traverses about one-half of Spain and the whole of Portugal, and, after a course of 500 miles, falls into the Atlantic 3 miles below Oporto. It is navigable for small vessels for about 70 miles.

Douw (dō'ū), GERARD. See *Dow*, Gerard.

Dove. See *Turtle-dove* and *Pigeon*.

Dove (dōv), a river, England, Derbyshire, after a course of 39 miles through highly picturesque scenery, falls into the Trent.



Doum Palm (*Hyphæne thebaica*).

Dove (dō've), HEINRICH WILHELM, German physicist, distinguished by his researches into the laws of climate and meteorological phenomena, was born in 1803, and died in 1879. Among his works are *Meteorological Researches* (1837), *Distribution of Heat on the Surface of the Globe* (1852), *Law of Storms* (1857).

Dove-plant. See *Holy Spirit Plant*.

Do'ver, a mun. and parl. borough of England, county Kent, 67 miles south-east of London. It lies on the coast of the Strait of Dover, and is 21 miles distant from Calais on the French coast. It is an important railway terminus, and as a port for mail and packet service with the Continent has a large passenger-traffic. Ship-building, sail-making, and fisheries are the chief industries. The harbour has been much improved in recent years. The entrance is protected by the Admiralty Pier, which is nearly half a mile in length. The celebrated castle of Dover stands on a chalk cliff 350 feet in height. Pop. 33,678.

Dover, Kent co., Del., capital of the State. Two factories, &c., 1 National Bank. Pop. 1890, 3061.

Dover, a city of the United States, in New Hampshire. It is situated on both sides of

the Cochecho, which has here a fall of over 30 feet, affording abundant water-power for the large iron and cotton manufactories. Pop. 1890, 12,790.

Dover, STRAITS OF, the narrow channel between Dover and Calais which separates Great Britain from the French coast. At the narrowest part it is only 21 miles wide. The depth of the channel at a medium in the highest spring-tides is about 25 fathoms. On both the French and English sides the chalky cliffs show a correspondency of strata which leaves no room for doubt that they were once united, although this is known otherwise.

Dover's Powder, a preparation frequently used in medical practice to produce perspiration. It consists of 1 grain of opium, 1 of ipecacuanha, and 8 of sulphate of potash in every 10 grains, which constitute a full dose. In preparing it the ingredients must be thoroughly mixed.

Dove-tailing, in carpentry, is the fastening boards together by letting one piece in the form of a dove-tail into a corresponding cavity in another. The dove-tail is the strongest kind of jointing.

Dovre-Fjeld (dō-vre-fyel), an assemblage of mountain masses in Norway, forming the central part of the Scandinavian system, and extending as a plateau 2000 feet high E.N.E. from lat. 62° N. to lat. 63°. It is generally composed of gneiss and mica schist. One of the mountains belonging to it is Snehaetta, 7620 feet.

Dow, or DOUW (properly DOU), GERARD, an eminent painter of the Dutch school, was the son of a glazier, and born at Leyden in 1613. He studied under Rembrandt, and united his master's manner in chiaroscuro with the most minute finish and delicacy. His pictures are generally of small size and mostly scenes of family life. Dow died in 1675.

Dower, in English law, is the right which a wife (not being an alien) has in the lands and tenements of which her husband dies possessed. By common law this right amounts to one-third of his estate during her life; by local custom it is frequently greater. Where the custom of *gavelkind* prevails the widow's share is a half, and that of *free-bench* gives her the whole of a copyhold. The term is also applied to the property which a woman brings to her husband in marriage, but this is more correctly *dowry*.

Dowlas, a kind of coarse linen formerly much used by working people for shirts;

this use of it is now generally superseded by calico.

Dowletabad. See *Daulatabad*.

Down, a county of Ireland, in Ulster, bounded on the north by Belfast Lough and on the east by the Irish Sea; area, 610,730 acres, of which over five-sixths are productive. Down is copiously watered by the rivers Bann, Lurgan, and Newry, and has numerous small lakes. The surface is very irregular, and in parts mountainous, Slieve Donard, in the Mourne Mountains, being 2796 feet high. Agriculture is comparatively advanced, oats, wheat, flax, and potatoes being the principal crops. The native breed of sheep is small, but valued for the delicacy of its mutton and the fine texture of its wool. The principal manufactures are linen and muslin. The fisheries on the coast, principally cod, haddock, and herring, are considerable. The county has four parliamentary divisions, each returning a member. The county town is Downpatrick; others are Newtonards and Banbridge. Pop. 1891, 266,893.

Downham Market, a market-town of England, Norfolkshire, on the Ouse, with an important trade in agricultural produce. Pop. 2633.

Downing College, one of the colleges of the University of Cambridge, chartered in 1800 and opened in 1821. Its founder was Sir George Downing, a Cambridgeshire gentleman.

Downpat'rick, a market-town and seaport of Ireland, county town of Down, 21 miles S.E. of Belfast. It is the seat of the diocese of Down Connor and Dromore, has a cathedral, and is celebrated as the supposed burial-place of St. Patrick. Pop. 3621.

Downs, a term given to undulating grassy hills or uplands, specially applied to two ranges of undulating chalk hills in England, extending through Surrey, Kent, and Hampshire, known as the North and South Downs. The word is sometimes used as equivalent to *dunes* or sand-hills.

Downs, THE, a celebrated roadstead for ships, extending 6 miles along the east coast of Kent in England, protected on the seaward side by Goodwin Sands.

Dowry. See *Dower*.

Doxology (from Greek *doxa*, praise, glory, and *logos*), a set form of words giving glory to God, and especially a name given to two short hymns distinguished by the title of *greater* (Glory be to God on high, &c.) and *lesser* (Glory be to the Father, &c.). Both

the doxologies have a place in the Church of England liturgy, the latter being repeated after every psalm, and the former used in the communion service.

Doyen (dwā-yän), GABRIEL FRANÇOIS, a French painter, born in 1726, was a pupil of Vanloo, and afterwards studied at Rome. Returning to Paris in 1753 he worked long without recognition, but at length won fame by his great picture, *Virginia's Death*. Catherine II. invited him to Russia, and appointed him professor in the Academy at St. Petersburg. He died June 5, 1806.

Doyle, RICHARD, an artist, born in London in 1826, died in 1883. He was long well known as a constant contributor of satirical designs to *Punch*, and also showed much talent in illustrations to Leigh Hunt's *Jar of Honey*, Thackeray's *Newcomes* and his *Rebecca and Rowena*, Ruskin's *King of the Golden River*, &c. Latterly he devoted himself to water-colour painting.

Dozy (dō'zi), REINHART, Dutch orientalist and historian, born 1820, died 1883. He was thoroughly versed in most of the Semitic tongues, and spoke and wrote almost all the European languages with facility. Among his works (sometimes in Dutch, sometimes in French) are *Histoire des Musulmans d'Espagne de 711-1110*; *Géographie d'Edrisi*; *De Israeliten te Mekka*; *Het Islamisme*; *Supplements aux Dictionnaires Arabes*.

Dracæ'na, a genus of endogenous evergreen plants, nat. order Liliaceæ. It includes the dragon-tree of Teneriffe (*D. Draco*), celebrated for producing the resin called dragon's blood. (See *Dragon's Blood*, *Dragon-tree*.) Several species of *Dracæna* are cultivated in greenhouses for the beauty of their foliage, but many of the fine plants known by this name belong strictly to other genera.

Drachenfels (drä'hen-fels; 'dragon rock'), 'the castled crag of Drachenfels,' as Byron calls it, a hill in Rhenish Prussia, about 8 miles south-east of Bonn, rising 900 feet above the Rhine, and crowned by the old castle of Drachenfels.

Drachma (drak'ma), the unit of weight and of money among the ancient Greeks. It was the principal Greek coin, was made of silver, and was worth (the Attic drachma) about 19½ cts. As a weight amongst the Greeks it was about 2 dwt. 7 grains troy.

Draco, a legislator of Athens, about 620 B.C., whose name has become proverbial as an inexorable and bloodthirsty lawgiver, and whose laws were said to have been written in blood, not ink.

Draco, the Dragon, a constellation of the northern hemisphere, containing, according to Flamsteed, eighty stars. The star γ Draconis is celebrated as the one used in determining the coefficient of aberration of the fixed stars.

Dracoceph'alum ('dragon's head'), a genus of odoriferous annual and perennial herbs, nat. order Labiatae, mostly found in the north of Asia, Europe, and America. The most generally cultivated species is *D. canariense*, or Canary balm of Gilead.

Dracun'culus, a genus of plants, nat. order Araceæ, with a long spotted stalk. They are natives of South Europe. *D. vulgaris* (green dragon) is common in English gardens. Its flowers are black, very fetid, and give out exhalations which produce headache, giddiness, and vomiting.

Draft, or DRAUGHT, a bill drawn by one person on another. (See *Bill*.) Also a rough copy of any document intended to be afterwards transcribed.

Drag, (1) a long coach or carriage, generally uncovered and seated round the sides. (2) An apparatus for retarding or stopping the rotation of one wheel or of several wheels, in carriages especially. (3) An apparatus, consisting of a frame of iron with a bag-net attached, used to recover articles lost in the water.

Drag-net, a net drawn along the bottom of a river or pond to catch fish. The use of drag-nets is usually prohibited in rivers where fish breed, as it takes all indiscriminately.

Drag'oman, a word of Eastern origin, the general name for a guide and interpreter among Europeans throughout the East, and especially in the Levant countries.

Drag'on, a fabulous monster, the stories



The Dragon of fable.

regarding which reach back almost as far as history. His form is described as generally resembling that of a winged and two-

legged serpent, the body covered with scales, the head crested, and the mouth spouting fire. The immediate source of the mediæval conception is probably the Scriptures, modified by accounts brought home by the Crusaders of the crocodiles in Egypt.

Dragon, one of the northern constellations. See *Draco*.

Dragon, or DRAGON-LIZARD, a name for several species of lizards inhabiting Asia, Africa, and South America. The common flying lizard (*Draco volans*), the best type of the genus, is about 10 or 12 inches in length, the tail being extremely long in proportion to the body. The sides are furnished with peculiar extensions of the skin, forming a kind of wings, which help to support it in the air when it springs from branch to branch. Its food consists almost exclusively of insects.

Dragon, GREEN, a plant. See *Dracunculus*.

Drag'onet, the common name of certain fishes of the Goby family. The gemmeous dragonet (*Callionymus lyra*) is found in the British seas.

Dragon-fly, a family (Libellulidæ) of neuropterous insects. They have a large head, large eyes, and strong horny mandibles. They are beautiful in form and colour, and are of very powerful flight. The great dragon-fly (*Æshna grandis*) is about 4 inches long, and the largest of the British species. They live on insects, and are remarkable for their voracity. The dragon-fly deposits its eggs in the water, where the larvæ and pupæ live on aquatic insects. The larval stage lasts for a year. The family is of very wide distribution. The small blue *Agrion* is a common European form. In the United States the Dragon-fly is known as the Devil's Darning-needle.

Dragonades, or DRAGONADES, the name given to the persecutions directed against the Protestants chiefly in the south of France, during the reign of Louis XIV. Bands of soldiers, headed by priests, marched through the villages, giving the Protestant inhabitants the alternative of renouncing their faith or being given over to the extortions and violence of the soldiery. The dragoons were conspicuous in these expeditions, to which they gave their name. The Dragonades drove thousands of French Protestants out of France.

Dragon's Blood, a resinous juice, usually obtained by incision from various tropical plants, as *Calāmus Draco*, *Dracæna Draco*,

Pterocarpus Draco, &c. It differs in composition, and is often much adulterated. It is opaque, of a reddish-brown colour, brittle, and has a smooth shining conchoidal fracture. It is soluble in alcohol and oil, but scarcely so in water. It is used for colouring varnishes, staining marble, leather, and wood, for tooth tinctures, &c.

Dragon's-head, a name of certain plants of the genus *Dracocephalum* (which see).

Dragon-tree (*Dracæna Draco*), a tree-like liliaceous plant, with a stem simple or divided at top, and in old age often much branched. It is a native of the Canaries, and yields the resin known as dragon's blood. It is often grown in stoves and greenhouses.

Dragoon', a kind of mounted soldier, so called originally from his musket (*dragon*) having on the muzzle of it the head of a dragon. At one time dragoons served both as mounted and foot soldiers, but now only as the former. In the British army there are *heavy* and *light dragoons*. The first dragoon regiment, the Scots Greys, was formed in 1681.

Dragoon-bird. Same as umbrella-bird.

Draguignan (drâ-gē-nyän), a town of Southern France, capital of dep. Var, in a beautiful valley, 41 miles north-east of Toulon. It has some interesting edifices and manufactures of silk, soap, and leather. Pop. 7961.

Drainage Tubes are used in surgery to effect a discharge of matter from an abscess or other collection of matter when a free incision cannot be safely or conveniently made. They are usually made of india-rubber or caoutchouc, and are introduced into the abscess or wound so that one end is in contact with the seat of discharge, while the other reaches to the surface of the skin.

Draining, in agriculture, a method of improving the soil by withdrawing the water from it by means of channels that are generally covered over. The successful practice of draining in a great measure depends on a proper knowledge of the superficial strata, of their situation, relative degrees of porosity, &c. Some strata allow water to pass through them, while others more impervious force it to run or filtrate along their surfaces till it reaches more level ground below. In general where the grounds are in a great measure flat and the soils of materials which retain the excess of moisture, they require artificial means of drainage to render them capable of yielding good crops whether of

DRAINING — DRAIN-TRAP.

grain or grass. The wetness of land which makes it inferior for agricultural purposes, may appear not only as surface-water but as water which flows through the lower strata, and to draw off these there are the two distinct operations of surface-draining and under-draining. The rudest form of

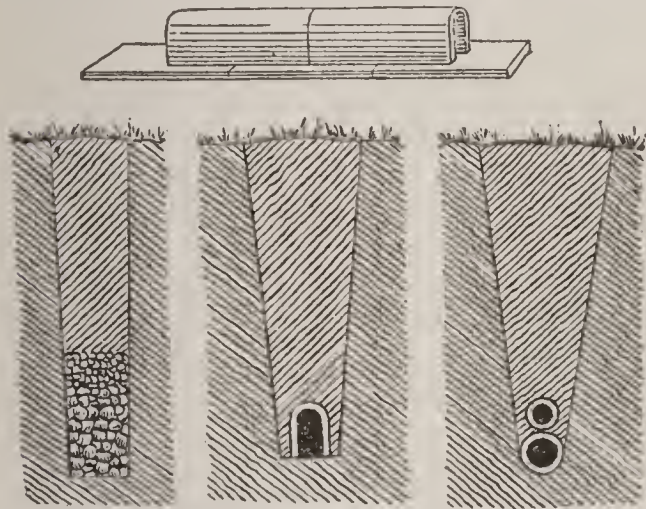

1, Horse-shoe tile with sole. Sections of Drain—2, Stone drain. 3, Drain with horse-shoe tiles. 4, Drain with pipe-tiles.

open drains are the deep furrows lying between high-backed ridges, and meant to carry off the surplus water after the soil is completely saturated, but in doing so they generally carry off also much of the best of the soil and of the manure which has been spread upon it. The ordinary ditch is a common form of water-course useful in certain cases, as in hill pastures. But covered drains at a depth of 4 ft. or so are the common forms in draining agricultural lands. They are generally either *stone-drains* or *tile-drains*. Stone-drains are either formed on the plan of open culverts of various forms, or of small stones in sufficient quantity to permit a free and speedy filtration of the water through them. The box-drain, for instance, is formed of flat stones neatly arranged in the bottom of the trench, the whole forming an open tube. In tile-drains, tiles or pipes of burnt clay are used for forming the conduits. They possess all the qualities which are required in the formation of drains, affording a free ingress to water, while they effectually exclude vermin, earth, and other injurious substances. Drainage tiles and pipes have been made in a great variety of forms, the earliest of which, since the introduction of thorough draining, was the horse-shoe tile, so called from its shape. These should always rest on soles, or flats of burned clay. Pipe tiles, which combine the sole and cover

in one piece, have been made of various shapes, but the best form appears to be the cylinder. An important department of draining is the draining off of the waters which are the sources of springs. Sometimes the judicious application of a few simple drains, made to communicate with the watery layers, will often dry swamps of great extent, where large sums of money, expended in forming open drains in the swamp itself, would leave it but little improved. In the laying out of drains the first point to be determined is the place of out-fall, which should always afford a free and clear outlet to the drains, and must necessarily be at the lowest point of the land to be drained. The next point to be determined is the position of the minor drains; in the laying out of which the surface of each field must be regarded as being made up of one or more planes, as the case may be, for each of which the drains should be laid out separately. Level lines are to be set out a little below the upper edge of each of these planes, and the drains must then be made to cross these lines at right angles. By this means the drains will run in the line of the greatest slope, no matter how distorted the surface of the field may be. All the minor drains should be made to discharge into mains or submains, and not directly into an open ditch or water-course. As a general rule there should be a main to receive the waters of the minor drains from every 5 acres. The advantages of drainage are obvious. In the first place it allows the soil to be brought into a more suitable condition for the growth of plants, aiding in producing the finely-divided and porous state by which the roots and rootlets can spread themselves at will in order to obtain the needed supplies of food, air, and moisture. It also allows the sun's rays to produce their full effect on the soil and plants without being robbed of great part of it by the stagnant water.

Drain-trap, a contrivance to prevent the

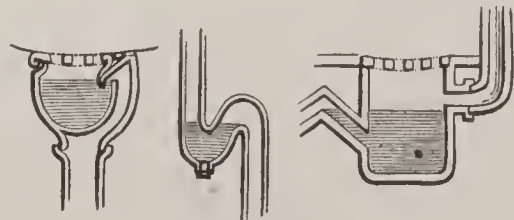

Drain-trap.

escape of foul air from drains, but to allow the passage of water into them. They are

of various forms. In the traps represented above it will be seen that there must always be a certain quantity of water maintained to bar the way against the escape of the gas from the drain or sewer. When additional liquid is conveyed to the trap there is of course an overflow into the drain. In the left-hand figure the gas is prevented from escaping by a metal plate thrown obliquely over the drain mouth and dipping into the water in the vessel beyond it.

Drake, SIR FRANCIS, an English navigator, born at Tavistock, in Devonshire, in 1539, or according to some authorities in 1545. He served as a sailor in a coasting



Sir Francis Drake.

vessel, and afterwards joined Sir John Hawkins in his last expedition against the Spaniards (1567), losing nearly all he possessed in that unfortunate enterprise. Having gathered a number of adventurers round him he contrived to fit out a vessel in which he made two successful cruises to the West Indies in 1570 and 1571. Next year, with two small ships, he again sailed for the Spanish Main, captured the cities of Nombre de Dios and Vera Cruz, and took a rich booty which he brought safely home. In 1577 Drake made another expedition to the Spanish Main, having this time command of five ships. On this the most famous of his voyages Drake passed the Straits of Magellan, plundered all along the coasts of Chili and Peru, sacked several ports, and captured a galleon laden with silver, gold, jewels, &c., to the value of perhaps £200,000. He then ran north as far as 48° N. lat., seeking a pas-

sage to the Atlantic, but was compelled to return to Port San Francisco on account of the cold. He then steered for the Moluccas, and holding straight across the Indian Ocean doubled the Cape of Good Hope, and arrived at Plymouth 3d Nov. 1580, being thus the first of the English circumnavigators. As there was no war between England and Spain the proceedings of Drake had a somewhat dubious character, but the queen maintained that they were lawful reprisals for the action of the Spaniards, and showed her favour to Drake by knighting him on board his own ship. Five years afterwards Drake was again attacking the Spaniards in the Cape Verd Islands and in the West Indies, and in 1588 particularly distinguished himself as vice-admiral in the conflict with the Spanish Armada. In 1593 he represented Plymouth in parliament. His later expeditions, that in 1595 against the Spanish West Indies and that to Panamá, were not so successful, and his death, which took place in 1596 at sea off Porto Bello, was hastened by disappointment.

Drakenberg Mountains, a range of S. Africa forming the western frontier of Natal, and rising to the height of 9000 ft., a continuation of the Quathlamba range.

Drama (Gr., from *draō*, I act), a class of writings which almost entirely consist of dialogue, persons being represented as acting and speaking, and the pieces being usually intended to be acted on a stage by parties assuming the characters of the respective persons. Its two great branches are tragedy and comedy, the former, roughly speaking, melancholy in character, the latter cheerful. The origin of the drama must be sought for in the love of imitation, and dramatic performances of some kind are to be met with probably among all nations. Dramatic compositions are found in the Old Testament, for example in Job and the Song of Solomon; and ancient India and China both developed a dramatic literature of their own. The European drama had its origin in Greece. Both forms, tragic and comic, took their rise in the celebrations of the Greek festivals of Dionysus (Bacchus), at which hymns and chants were sung by choruses in honour of the god, and the chorus continued to be a prominent feature of the old Greek drama. Greek comedy commenced about 580–560 B.C. with Susarion, but it was long in attaining regular form. Of the old Greek comedy the chief representatives were Cratinus, Eupolis, Pherecrates, and Aristot-

DRAMA.

phanes—the last the greatest. The invention of tragedy is generally ascribed to Thespis about 530 B.C., who was followed by Phrynichus. But the true creator of tragedy was Æschylus, in whose works and those of Sophocles and Euripides it found its most perfect expression. Thespis had only one actor, who from time to time relieved the chorus by declamation. Æschylus changed this representation into real action by making use of two actors in addition to the chorus. Æschylus also introduced masks; and by means of a long gown and the *cothurnus*, or buskin, the lofty stature of the heroes was imitated. A third actor was first introduced by Sophocles. The accommodations for the spectators were improved, and machinery and scenery introduced. The theatres, which had been formerly built of wood, were now large stone erections, capable of containing the greater number of the citizens. The regular drama among the Romans was borrowed from the Greeks. Plautus and Terence were imitators of the Greek comedy, Livius Andronicus (240 B.C.) of the Greek tragedy. Of the Roman tragedy, the dramas of Seneca are the only specimens extant.

In most modern European countries the regular drama took its rise in the mysteries, miracle-plays, and moralities of the middle ages (see these terms). In Italy, however, it began with a reproduction in Latin of classical models. The earliest tragedy in Italian is Trissino's *Sofonisba* (1502). Regular comedies in Italian were written by Ariosto, Aretino, Macchiavelli, and others; and to the same period (15th and 16th centuries) belongs the Italian Pastoral Drama, which sprung from the ancient idylls, and aimed at a fanciful delineation of Arcadian and mythological scenes. Among the pastoral dramatists of this period are Poliziano, Tasso, and Guarini. The pastorals gave birth to the *opera*, early masters of which, so far as it may be included in the poetic drama, are Zeno and Metastasio. The Italian drama waned in the 17th century, but in the 18th genuine comedy and classic tragedy were restored, the former by Goldoni, the latter by Alfieri. Monti, Manzoni, and Niccolini are among the later writers of tragedy.

The other European nations cultivated the dramatic art much later than the Italians. The English and Spaniards devoted their attention to it almost at the same time; the former reaching their acme

in Shakspeare, the latter in Lope de Vega and Calderon. The history of the English theatre and the drama is naturally divided into two parts, the first of which begins with the reign of Elizabeth and ends with the reign of Charles I. The rapid development of the drama during the reign of Elizabeth was entirely unhampered by foreign influence. Lyly, Peele, Greene, Marlowe, Shakspeare, Ben Jonson, Beaumont and Fletcher, Chapman, Webster, Middleton, Marston, Ford, and Massinger are among the chief names connected with the brilliant period of the English drama. During the Commonwealth the Puritans prohibited all kinds of plays, and the theatres were shut up for thirteen years. With Charles II. the drama reappeared, and exhibited a licentiousness hardly equalled by that of any other Christian nation. Among the chief names belonging to this period are Dryden, Otway, Lee, Shadwell, Wycherley, and Etherege. From the close of the 17th to that of the 18th century British comedy was cultivated with much success by Cibber, Farquhar, Congreve, Sheridan, and others. During the 19th century many writers have been conspicuous by their dramas. Among the chief of these may be noted Byron, Coleridge, Landor, Shelley, Maturin, Talfourd, Milman, Sir Henry Taylor, the first Lord Lytton, Knowles, R. H. Horne, Arnold, Browning, Swinburne, and Tennyson. Among other 19th-century writers for the stage, who, however, may be called playwrights rather than dramatists, may be named, Douglas Jerrold, Tom Taylor, Charles Reade, Thomas Robertson, W. G. Wills, Henry Byron, Robert Buchanan, Dion Boucicault, W. S. Gilbert, &c.

The French drama was in a miserable state before Corneille (1606–84), who indeed is looked on as the founder of the drama in France. Racine, Molière, Voltaire, and in later times Hugo, are some of the other distinguished French dramatists. Since about 1820 a new dramatic school has been formed in France, which, departing from the ancient strictness of what is called the *classic*, approaches more and more to the German or British, or what is called the romantic school. The establishment of this school formed part of the general reaction against the excessive adherence to classic models in literature, the leader in the movement being Victor Hugo. C. Delavigne marks the transition from the classical to the beginnings of the romantic school, and

among the modern dramatists may be mentioned A. de Vigny, George Sand, A. de Musset, Mérimée, Ponsard, Augier, Scribe, Dumas the Younger, and Sardou.

The German drama is of later birth than any we have mentioned, and for a long time the Germans contented themselves with translations and adaptations from the French. Lessing was the first who, by word and deed, broke the French sway (1755), and he was succeeded by Schiller and Goethe, who rank as the greatest of the more modern dramatists. Prominent names in the German drama are Kotzebue, Körner, Schlegel, Tieck, Brentano, Grillparzer, Heibel, Ludwig, Gutzkow, Freytag, Laube, Von Moser, &c. The Dutch drama begins with the classical tragedies of Koster in the beginning of the 17th century, and reached its highest in Vondel (1587-1659). Holberg, Heiberg, Oehlenschläger, Ibsen, and Björnson are the chief names connected with the Scandinavian drama.

The literature of the drama in the U. States is extensive, but a great proportion of it is of little value. The first play by an American author presented on the stage was *Contrast*, by Royal Tyler. Some of the writers who have been most prominent are John Howard Payne, Wm. Dunlap, David Paul Brown, Robert M. Bird, N. H. Bannister, R. T. Conrad, G. H. Boker, Epes Sargent, Dr. J. S. Jones, Dr. W. K. Northall, N. P. Willis, Bartley Campbell, Bronson Howard, Augustus Thomas, David Belasco, Sidney Rosenfeld, Wm. Gillette, Paul M. Potter, H. G. Carleton, Martha Morton, Fitch, Hoyt, Harrigan, and Byrne.

Draper, JOHN WILLIAM, M.D., LL.D., chemist and physiologist, born at Liverpool 1811, died 1882. He went to America in 1832, and was successively professor of physical science in Hampden-Sidney College, Virginia, and of natural history, chemistry, and physiology in the University of New York. He made many contributions to scientific literature, and devoted much attention to the chemical action of light, in connection with which he effected some discoveries. Among his chief works is his *History of the Intellectual Development of Europe*. His son, HENRY DRAPER (born 1837, died 1882), chemist and astronomer, made some valuable researches on the spectra of the heavenly bodies.

Drapery, the clothes or hangings with which any object is draped or hung; specifically in *sculpture* and *painting*, the repre-

sentation of the clothing or dress of human figures.

Drapier Letters, THE. See *Swift, Jonathan*.

Draught, the depth of a body of water necessary to float a ship; or the depth a ship sinks in water, especially when laden.

Draughts, a game resembling chess played on a board divided into sixty-four checkered squares. Each of the two players is provided with twelve pieces or 'men' placed on every alternate square at each end of the board. The men are moved forward diagonally to the right or left one square at a time, the object of each player being to capture all his opponent's men, or to hem them in so that they cannot move. A piece can be captured only when the square on the diagonal line behind it is unoccupied. When a player succeeds in moving a piece to the further end of the board (the crown-head), that piece becomes a king, and has the power of moving or capturing diagonally backwards or forwards. When it so happens that neither of the players has sufficient advantage in force or position to enable him to win, the game is drawn. *Checkers* is the common American name of the game.

Drave, or DRAU (drá've, drou), a European river which rises in Tyrol, flows E.S.E. across the north of Illyria and the south of Styria, and between Hungary on the left and Croatia and Slavonia on the right, and after a course of nearly 400 miles joins the Danube 14 miles east of Essek. It is navigable for about 200 miles.

Dravid'ian, a term applied to the vernacular tongues of the great majority of the inhabitants of Southern India, and to the people themselves who must have inhabited India previous to the advent of the Aryans. The Dravidian languages are generally considered to belong to the Turanian class, and the family consists of the Tamil, Telugu, Canarese, Malayalam, Tulu, Tuda, Gond, Rajmahal, Oraon, &c. Only the first four mentioned have a literature, that of the Tamil being the oldest and the most important.

Drawback, usually a certain amount of duties or customs dues paid back or remitted to an importer when he exports goods that he has previously imported and paid duty on, as, for instance, tobacco, &c.; or a certain amount of excise paid back or allowed on the exportation of home manufactures.

Drawbridge, a bridge with a lifting floor, such as were formerly used for crossing the

ditches of fortresses, or any movable bridge over a navigable channel where the height of the roadway is insufficient to allow vessels to pass underneath. Modern draw-bridges across rivers, canals, the entrances of docks, &c., are generally made to open horizontally, and the movable portion is called a bascule, balance, or lifting bridge, a turning, swivel, or swing bridge, or a rolling bridge, in accordance with the mode in which it is made to open. Swing-bridges are usually divided into two parts meeting in the middle, and each moved on pivots on the opposite sides of the channel, or they may move as a whole on a pivot in the middle of the channel. Rolling bridges are suspended from a structure high above the water, and are propelled backwards and forwards by means of rollers.

Drawing is the art of representing upon a flat surface the forms of objects, and their positions and relations to each other. The idea of nearness or distance is given by the aid of perspective, foreshortening, and gradation. The term drawing, in its strict sense, is only applicable to the representing of the forms of objects in outline, with the shading necessary to develop roundness or *modelling*. In art, however, the term has a wider significance. Highly-finished paintings in water-colour are called *drawings*, as are also sketches or studies in oils. Drawing, in its restricted sense, may be divided into these kinds: (1) *pen drawing*; (2) *chalk drawing*, which may include lead-pencil drawing; (3) *crayon drawing*; (4) *drawing shaded with the brush or hair-pencil*; (5) *architectural or mechanical drawing*. *Pen drawings* are often confined to pure outlines; an appearance of *relief* or projection being given by thickening or doubling the lines on the shadow side. *Finished pen drawings* have all the shading produced by combinations of lines. *Chalk drawings* (including lead-pencil drawings) are most suited for beginners, as errors can be easily corrected. Black, red, and white chalks are used. When the chalk is powdered and rubbed in with a stump, large masses and broad effects can be produced with much rapidity. A combination of hatching and stumping is generally preferable to adhering exclusively to either mode. *Crayon drawings* are those in which the true colours of the objects represented are more or less completely wrought out with different coloured crayons. *Drawings shaded with the brush* are outlined with the pencil or pen, the shading being laid on

or *washed in* with the brush in tints of Indian ink, sepia, or colour. *Architectural and mechanical drawings* are those in which the proportions of a building, machine, &c., are accurately set out for the guidance of the constructor: objects are in general delineated by geometric or orthographic projection. The great schools of painting differ from one another as much in their drawing as in their painting. In Italy the Roman school, through Raphael's fine sense for the beautiful and expressive in form, and through his study of the antique, became the true teacher of beautiful drawing. The Florentine school tried to surpass the Roman precisely in this particular, but it lost by exaggeration what it had gained by learning and a close study of anatomy. In the Lombard school a tender style of drawing is seen through harmonious colouring, and in the Venetian school the drawing is often veiled in the richness of the colour. The Dutch school excels in a careful and minute style of naturalistic drawing, combined with great excellence in colouring. The French school in the time of Poussin was very accurate in its drawing; at a later period its style betrayed a great amount of mannerism. David introduced again a purer taste in drawing and a close study of the antique, and these are qualities which distinguish his school (the so-called classical school) from the romantic and eclectic schools of a later period. The drawing of the British school is naturalistic rather than academic. It has of late years much improved in accuracy and expressiveness.

Drawing-room, a room appropriated for the reception of company; a room in which distinguished personages hold levees, or private persons receive parties.—*Court drawing-rooms* are those assemblies held from time to time for the reception or presentation to the sovereign of such ladies as by custom, right, or courtesy are admissible. Gentlemen are not expected unless in attendance on the ladies of their families. The sovereign sometimes deputed a member of the royal family to receive, in which case presentations are equivalent to those made to the sovereign in person.

Drayton, MARKET, or DRAYTON-IN-HALES, a town, England, county Salop, 18 miles north-east of Shrewsbury. It has a church, supposed to have been erected, with exception of the steeple, in the reign of William I. There are paper and hair-cloth manufactories. Pop. 5954.

Drayton, MICHAEL, an English poet, born in 1563, is said to have studied at Oxford, and afterwards held a commission in the army. The poem by which his name is chiefly remembered is his *Polyolbion*, a sort of topographical description of England. It is generally extremely accurate in its details, with, at the same time, many passages of true poetic fire and beauty. Other works are his *Nymphidia*, the *Court of Fairy*; the *Barons' Wars*; the *Legend of Great Cromwell*; the *Battle of Agincourt*; besides numerous legends, sonnets, and other pieces. Drayton was made poet-laureate in 1626. He died in 1631, and was buried in Westminster Abbey.

Dreams, trains of ideas which present themselves to the mind during sleep. The principal feature of the state of dreaming is the absence of voluntary control over the current of thought, so that the principle of suggestion has unlimited sway. There is usually an utter want of coherency in the images that appear before the mental eye, but this want excites no surprise in the dreamer. Occasionally, however, intellectual efforts are made during sleep which would be difficult to surpass in the waking state. It is said that Condillac often brought to a conclusion in his dreams reasonings on which he had been employed during the day; and that Franklin believed that he had been often instructed in his dreams concerning the issue of events which at that time occupied his mind. Coleridge composed from 200 to 300 lines during a dream: the beautiful fragment of *Kubla Khan*, which was all he got committed to paper when he awoke, remains a specimen of that dream-poem. Dreams are subjective phenomena dependent on natural causes. They generally take their rise and character from external bodily impressions, or from something in the preceding state of body or mind. They are, therefore, retrospective and resultant instead of being prospective or prophetic. The latter opinion has, however, prevailed in all ages and among all nations; and hence the common practice of divination or prophesying by dreams, that is, interpreting them as presages of coming events. Some authorities declare that all our dreams take place when we are in process of going to sleep or becoming awake, and that during deep sleep the mind is totally inactive. This is denied by the majority of philosophers, and with apparent reason.

Dredging, a term applied to the operation

of removing mud, silt, and other deposits from the bottom of harbours, canals, rivers, docks, &c. The most simple dredging apparatus is the spoon apparatus, which consists of a strong iron ring or hoop, properly formed for making an impression upon the soft matter at the bottom, so as to scoop it into a large leather bag attached to the ring and perforated with a number of small holes. The means for working it is a long handle, a suspending rope, and a crane or sweep-pole planted in a boat. Much more effective is the steam dredging-machine now in common use. It has a succession of strong iron buckets on an endless chain, which traverses on a frame whose lower end is vertically adjustable so as to regulate the depth at which it works. It is worked by steam, and the buckets tear up the matter at the bottom, raise it, and discharge it into punts or hoppers stationed close to the dredging vessel. On p. 224 is shown a steam-dredger of the most improved type, as used on the river Clyde, a river which, from being a shallow stream, has been converted, mainly by dredging, into a waterway capable of carrying the largest vessels up to Glasgow. Dredging is also the operation of dragging the bottom of the sea in order to bring up oysters, or to procure shells, plants, and other objects for scientific observation. The oyster dredge is a light iron frame with a scraper like a narrow hoe on one side, and a suspending apparatus on the other. To the frame is attached a bag made of some kind of netting to receive the oysters. The dredges used by naturalists are mostly modifications of the oyster dredge.

Dred Scott Decision. This decision of the U. States Supreme Court, delivered by Chief-Justice Taney, March 6, 1856, awakened intense interest. The plaintiff, Dred Scott, was a slave in Missouri; his owner took him to Illinois state, and also Minnesota, then a territory, both free soil, where he kept him for years, afterward moving back to Missouri, a slave state. The plea of Scott was that his residence in Illinois and Minnesota made him a free man. The decision was that he was a chattel, 'without rights or privileges except such as those who held the power and the government might choose to grant him.' The decision nationalized slavery by degrading the slave to the level of a horse or a plow, and overrode every sentiment of humanity respecting him. Thenceforth the settlement of the slavery question drifted toward armed arbitrament.

DRENTHE — DRESDEN.

Drenthe (dren'te), a province, Holland, bounded by Hanover, Overijssel, Friesland, and Groningen; area, 948 square miles. It is in general more elevated than the surrounding provinces, especially in the centre. The soil is generally poor, and the surface largely consists of heath and morass, but the province is famed for its horses and cattle. Drenthe is remarkable for the great number of so-called 'giants' graves' or barrows scattered over the country. Its capital is Assen. Pop. 1892, 134,027.

Dres'den, the capital of the kingdom of Saxony, is situated in a beautiful valley on both sides of the river Elbe, which is here spanned by three stone bridges. It is first mentioned in history in 1206, and has been the residence of the sovereigns since 1485; was greatly extended and embellished by Augustus the Strong (1694-1736), and has rapidly increased during the 19th century. Among the chief edifices besides several of the churches are the Museum (joined on to an older range of buildings called the Zwin-

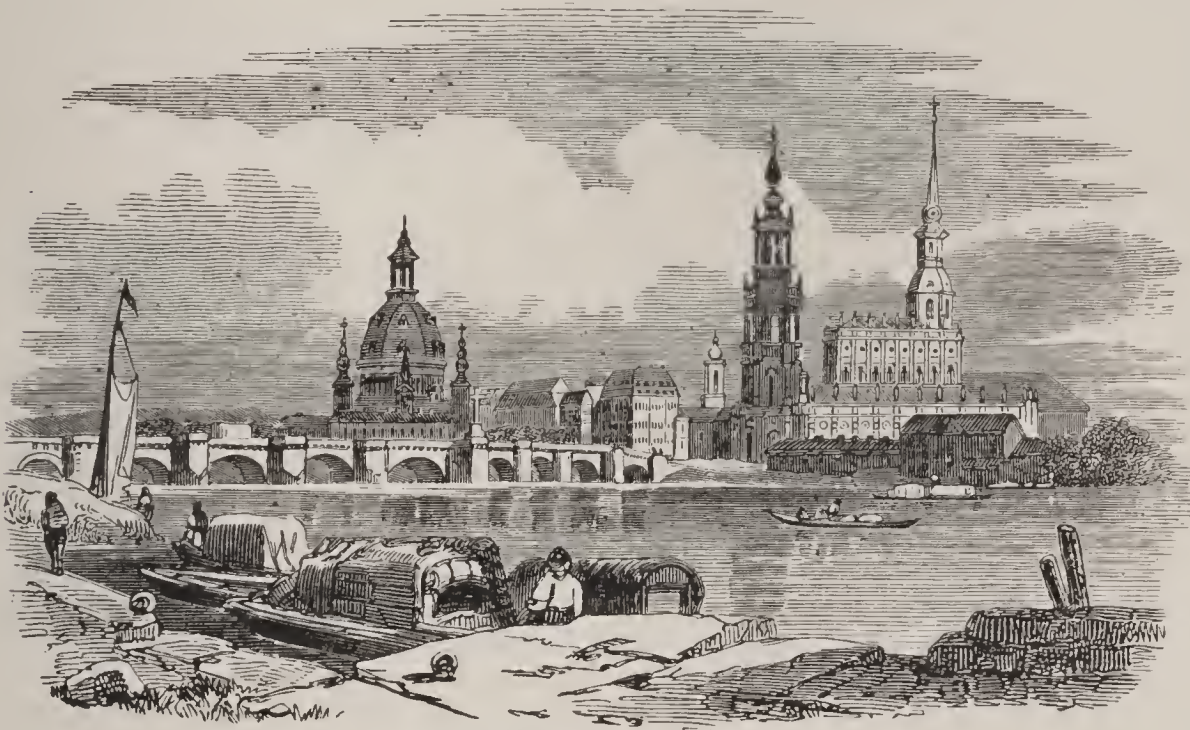

Dresden—The Old Bridge, Court Church, and Church of Our Lady.

ger), a beautiful building containing a famous picture-gallery and other treasures; the Japanese Palace (Augusteum), containing the royal library of from 300,000 to 400,000 volumes, besides a rich collection of manuscripts; the Johanneum, containing the collection of porcelain and the historical museum, a valuable collection of arms, armour, domestic utensils, &c. belonging to the middle ages. The royal palace is unattractive externally, but has a fine interior. It contains (in what is called the Green Vault) a valuable collection of curiosities, jewels, trinkets, and works of art. The theatre is one of the finest structures of the kind in the world. The city is distinguished for its excellent educational, literary, and artistic institutions, among which are the Polytechnic School, much on the plan and scale of a university; the Conservatory and School of Music; the Academy of Fine Arts, &c. The manufactures are not unim-

portant, and are various in character; the china, however, for which the city is famed, is made chiefly at Meissen, 14 miles distant. The commerce is considerable, and has greatly increased since the development of the railway system. The chief glory of Dresden is the gallery of pictures, one of the finest in the world, which first became of importance under Augustus II., king of Poland and elector of Saxony, but owes its most valuable treasures to Augustus III., who purchased the greater portion of the gallery of the Duke of Modena for £180,000. The pictures number about 25,000, and in particular comprise many fine specimens of the Italian, Dutch, and Flemish schools. Besides this fine collection the museum contains also engravings and drawings amounting to upwards of 350,000. There is here also a rich collection of casts exemplifying the progress of sculpture from the earliest times, and including copies of all the most

important antiques. Dresden being thus rich in treasures of art, and favoured by a beautiful natural situation, is the summer resort of many foreigners. It suffered severely in the Thirty Years' war, and also in 1813, when it was the head-quarters of Napoleon's army. It was occupied by the Prussians in 1866, but was evacuated in the following spring. Pop. 1890, 289,844.

Dresden, **BATTLE OF**, a battle fought in 1813 between the French under Napoleon and the allies under Schwarzenberg. Napoleon had come to the relief of the city, which was occupied by the French. The allies assaulted and bombarded the city, and soon after a great pitched battle was fought (27th Aug.), the allies being defeated.

Dresden China, a delicate, semi-transparent, highly-finished china made at Meissen, near Dresden. The manufacture resulted from an accidental discovery made by Böttger, a young chemist, in 1710, and the vases, statuettes, groups of figures, candelabra, clocks, &c., manufactured during the 18th century are highly prized. They are more remarkable for excellence of execution than for purity of design.

Drexel, **ANTHONY J.**, banker, was born in Philadelphia, Pa., in 1826. He was the head of the well-known firm of Drexel & Co., Philadelphia, having been identified with it since the age of 13. He was zealous in promoting science and art, especially music, and contributed largely to philanthropic and educational interests. The Drexel Institute of Art, Science and Industry, Philadelphia, dedicated December 18, 1891, was established by Mr. Drexel, the building costing over \$600,000, with an endowment fund of \$1,000,000. His name is associated with that of his friend, George W. Childs, in the inception of the Childs-Drexel Home for Union Printers, Colorado Springs, Col., dedicated in 1892; they each contributing \$5000. He died June 30, 1893.

Dreyfus, **ALFRED**, a captain in the French army; was arrested in Oct., 1894, for having furnished to a foreign government documents which he had copied at the Ministry of War. He was transported March, 1895, to Devil's Island, a rock off French Guiana. M. Émile Zola pleaded for a new trial for Dreyfus, and was himself summoned before the Court of Assizes as being guilty of anti-patriotic measures. Great anti-semitic riots occurred in Paris in 1898 as a consequence of this agitation.

Drift, in geology, a term applied to earth

and rocks which have been conveyed by icebergs or glaciers and deposited over the surface of a country; variously called *Diluvium*, *Diluvial*, *Glacial*, or *Northern Drift*, *Boulder Formation*, &c. Geologists now often use instead of *Drift* the terms *stratified* or *unstratified Boulder Clay*, which were not formerly recognized as distinct formations.

Drift, in mining, the course or direction of a tunnel or gallery; or a passage between two mine shafts.

Drift Sand, sand thrown up by the waves of the sea, and blown when dry some distance inland until arrested by large stones, tree roots, or other obstacles, round which it gradually accumulates until the heaps attain considerable dimensions, often forming dunes or sand-hills.

Drill, a tool used for boring holes in wood, metal, stone, ivory, &c. It consists of a sharp chisel to which a circular motion is communicated by various contrivances. For drilling iron, steel, &c., a lathe driven by steam is generally used, the drill being fixed into a chuck and the work pressed against it as it revolves. For rock-boring the diamond rock-drill, an instrument with cutting edges made of boart or black diamond, is now generally adopted. See *Boring*.

Drill, a fine linen texture of a satiny finish, used for gentlemen's summer dresses. Plain drills are worked with five shafts, fancy patterns with eight.

Drill, the course of instruction in which a soldier or sailor is taught the use of arms and the practice of military and naval evolutions.

Drill (*Cynocephalus leucophaeus*), a species of baboon, of a smaller size and less fierce disposition than the mandrill, and like it a native of the coast of Guinea. The face and ears are bare and of a glossy black colour, the palms of the hands and soles of the feet are also naked and of a deep copper colour.

Drilling, the plan of sowing in parallel rows as distinguished from sowing broadcast. It was introduced into England by Jethro Tull, who published a work on the subject in 1731. The crops which are now generally drilled are turnips, potatoes, beans, pease, carrots, clover, cereals, flax, &c. The first form of drill was of very simple construction, and was only adapted for sowing one row at a time.

Drink. See *Dietetics*.

Drinking Fountain, an erection, often ornate and artistic, on or near a public

thoroughfare or place of resort, for supplying people, and sometimes also horses, dogs, &c., with water to quench their thirst.

Dripstone, a projecting tablet or moulding over the head of a doorway, window, archway, or niche to throw off the rain. It

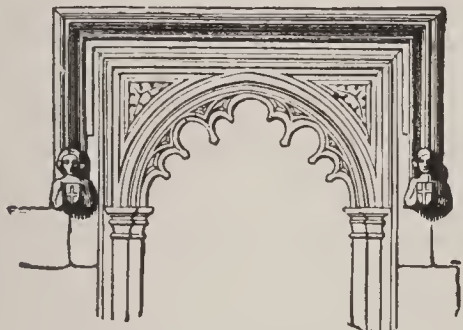

Dripstone, Westminster Abbey.

is also called a *weather moulding*, and *label* when it is turned square. It is of various forms; sometimes a head is used as a termination or support, at others an ornament or simple moulding is adopted.

Driving, CARELESS or FURIOUS, was made a statutory offence in Britain by an act passed in 1861, and special penalties are also introduced into local acts.

Driving-wheel, in machinery, a wheel that communicates motion to another or others; in railway locomotives the large wheel which is fixed upon the crank-axle or main shaft.

Drogheda (droh'e-da), an ancient town and seaport, and county of itself, formerly a parl. borough, Ireland, in the counties of Meath and Louth, on both sides of the Boyne, about 4 miles from the sea, 26 miles north of Dublin. The Boyne is here crossed by a railway viaduct of 18 arches and 95 feet high. Flax and cotton spinning are carried on; there are also salt-works, breweries, and tanneries; and the fisheries are increasing. There is a good export trade in cattle, sheep, grain, butter, eggs, &c. The town was for a long time strongly fortified, and was taken by Cromwell with great slaughter in 1649; it surrendered to William III. immediately after the battle of the Boyne. Pop. 1891, 11,812.

Drohobycz (dro'ho-bich), a town, Austria, in Galicia, 41 miles s.s.w. Lemberg. Its Catholic church is one of the handsomest in the country. It has an important trade, particularly in salt, obtained from springs in the vicinity. Pop. 15,714.

Droit d'Aubaine (drwä-dō-bān), an old rule in some European countries, by which

the property of a deceased foreigner was claimed by the state, unless the defunct had a special exemption. In France, where it was not abolished till 1819, the Scotch, Savoyards, Swiss, and Portuguese were exempted.

Droitwich (droit'ich), a town and parl. division of England, in the county and 6 miles N.N.E. of Worcester, on the Salwarp. It is famous for its brine springs, from which salt has been manufactured for more than 1000 years. Pop. of town, 3761.

Drôme, a south-east department of France, covered almost throughout by ramifications of the Alps, the average height of which, however, does not exceed 4000 feet; area, 2508 square miles, of which about one-fourth is waste, one-third under wood, and a great part of the remainder under tillage and pasture. A considerable extent of the area is occupied by vineyards, and several of the wines produced have a high reputation, especially Hermitage. Olives, chestnuts, and silks are staple productions. Valence is the capital. Pop. 1891, 306,419.

Dromedary. See *Camel*.

Dromore', an episcopal city, Ireland, county Down, on the Laggan, here crossed by two bridges, 16 miles south-west of Belfast. Its cathedral contains the tomb of Jeremy Taylor. Pop. 2491.

Drontheim (dronth'im). See *Trondhjem*.

Dropsy, a disease which consists in the collection of serous or watery fluid in the cellular tissue, or in different cavities of the body. It receives different appellations according to the particular situation of the fluid. When it is diffused through the cellular tissue, either generally or partially, it is called *anasarca*; when it is deposited in the cavity of the cranium it is called *hydrocephalus*; when in the chest, *hydrothorax*, or *hydrops pectoris*; when in the abdomen, *ascites*; in the uterus, *hydrometra*; within the scrotum, *hydrocele*; and within the ovary, *ovarian dropsy*. Obstructive organic disease of the heart and degenerative diseases of the kidneys are the most common causes of general dropsy. The treatment often includes removal of the fluid from the cavities containing it by tapping or puncturing; otherwise drugs which stimulate excretion by the skin, bowels, and kidneys are employed, but all remedies frequently prove ineffectual.

Drop-wort (from the small tubers on the fibrous roots), *Spiraea filipendula*, nat. order Rosaceæ, a British plant of the same genus

as queen-of-the-meadow, found in dry pastures. The hemlock drop-wort, or water drop-wort, is *Enanthe fistulōsa*.

Drosera'ceæ, a nat. order of albuminous, exogenous plants, consisting of marsh herbs, whose leaves are usually covered with glands or glandular hairs. It contains six genera, including the sundew (*Drosēra*), and Venus's fly-trap (*Dioncēa*). (See *Sundew* and *Dioncēa*.) They have no known qualities except that they are slightly bitter. The leaves are generally circinnate in the bud, as in ferns.

Drosky, a kind of light, four-wheeled carriage used by the Russians. It is not covered, and in the middle there rises a sort of bench placed lengthways on which the passengers ride as on a saddle; but the name is now applied to various kinds of vehicles, as to the common cabs plying in the streets of German cities, &c.

Drosom'eter (Greek, *drosos*, dew, and *metron*, a measure), an instrument for ascertaining the quantity of dew which falls. It consists of a balance, one end of which is furnished with a plate fitted to receive the dew, the other containing a weight protected from it.

Drouais (drö-ā), JEAN GERMAIN, French historical painter of considerable repute, born at Paris in 1763, died at Rome 1788. His chief pictures are The Canaanitish Woman at the Feet of Jesus; Dying Gladiator; and Marius at Minturnæ;

Drouet (drö-ā), JEAN BAPTISTE, Comte d'Erlon, French general, born 1765, died 1844. He served in the campaigns of the Moselle, Meuse, and Sambre (1793-96), in the Peninsula, and at Waterloo, where he commanded the first corps d'armée. In 1834-35 he was Governor-general of Algeria, and in 1843 was made a marshal.

Drouyn de Lhuys (drö - an dé lwēs), ÉDOUARD, French statesman and diplomatist; born 1805, died 1881. He entered the diplomatic service in 1831, and was chargé-d'affaires at the Hague during the events which led to the separation of Belgium from Holland. In 1840 he was head of the commercial department under the minister of foreign affairs. Opposition to Guizot caused his dismissal in 1845. He became minister for foreign affairs in 1848, ambassador to London in 1849; and again foreign minister in 1851, and in 1863. On the fall of the empire he fled to Jersey, but subsequently returned to France.

Drowning means death by the air being prevented entering the lungs owing to the

mouth and nostrils being immersed in a liquid, the liquid being commonly water. Death may, therefore, occur by drowning in a small quantity of water. Thus a child may fall head downwards into a tub and be drowned, though the tub is not half full of water, sufficient to cover the mouth and nostrils being all that is necessary, and a man overcome by a fit or by drunkenness may fall on a road with his head in a ditch or pool of water, and thus meet death. Death is thus due to suffocation, to the stoppage of breathing, and to the entrance of water into the lungs. When death has been caused by drowning, the skin presents the appearance called goose-skin (*cutis anserīna*), the face and surface of the body generally are usually pale, a frothy liquid is found in the lungs and air-passages, and about the lips and nostrils; water may be found in the stomach, and clenched fingers, holding substances grasped at, may serve to show that a struggle has taken place in the water, and that the body was alive at the time of immersion. Complete insensibility arises, it is probable, in from one to two minutes after submersion, recovery, however, being still possible, and death occurs in from two to five minutes. So long as the heart continues to beat, recovery is possible; after it has ceased it is impossible. Newly-born children and young puppies stand submersion longer than the more fully grown.

For the restoration of the apparently drowned several methods are suggested. Those of Dr. Sylvester, recommended by the English Humane Society, and Dr. Benjamin Howard, of New York, will be described.

Whichever method is adopted, the following steps must first and immediately be taken: Pull the body up on to dry ground. Send immediately for medical assistance, warm blankets, dry clothing, brandy and hot water, if any one is at hand to send. No delay must be permitted, however, in treating the person, so that if only one person is on the spot he must begin to treat the person *instantly*, without seeking assistance. Remove all clothing from the neck and chest. Fold the articles of dress removed so as to make a firm pillow, which is to be placed under the shoulders, so that the upper part of the body is slightly raised and the head slightly thrown back. Cleanse the mouth and nostrils, open the mouth and pull forward the tongue. If natural efforts to breathe are made, try to stimulate them

DROWNING.

by brisk rubbing of the sides of the chest and of the face. If no effort to breathe is made, proceed to produce the entrance and outflow of air from the lungs by Sylvester's or Howard's method.

Sylvester's method: stand or kneel behind the person's head, grasp each arm at the elbow, draw both arms simultaneously upwards till they are extended in line with

the body, as a man places them when he stretches himself. Let this movement occupy about 2 seconds. This enlarges the chest and causes the entrance of air to the lungs. Without a pause carry the arms down to the sides, making them overlap the chest a little, and firmly press them on the chest. This movement should occupy other 2 seconds. It expels air from the lungs.



Fig. 1.



Fig. 2.

Howard's Method for Restoring the apparently Drowned.

Repeat the movements, and maintain them steadily and patiently at the rate of 15 times a minute, until breathing has been fully restored, or until medical aid arrives, or until death is certain. An hour is not too long a time to persist, and so long as there seems the least effort to breathe the efforts must be persevered in.

Howard's method: Place the body on its face, with the roll of clothing under the stomach; the head being supported on the hand as shown in figure 1. Pull the body over the roll of clothing to expel water from the chest. Then turn the body on the back, the shoulders being supported as shown in fig. 2. Kneel over the body. Place both hands on the lower part of the chest, so that the thumbs hook in under the lowest ribs

and the fingers are spread out on the chest. Steadily press forwards, raising the ribs, your own body being thus thrown leaning forward. This enlarges the cavity of the chest and causes air to enter. When the ribs have been raised to the utmost extent, with a slight effort push yourself back to the more erect position, allowing the ribs to recoil to their former position. This expels the air. Repeat the process 15 times a minute. One person will find it more easy to maintain this method for a prolonged period than Sylvester's, especially if the patient be big and heavy.

Meanwhile, if other persons are present they should be occupied rubbing the body and limbs (*always upwards*) with hands or warm flannel, applying hot flannels, bottles,

&c., to the limbs, feet, arm-pits, &c. As soon as the person is sufficiently restored to be able to swallow, give small quantities of hot brandy and water, hot wine and water, hot coffee, &c., and use every effort to restore and maintain warmth.

Drowning was formerly a mode of capital punishment in Europe. The last person executed by drowning in Scotland suffered death in 1611. In Ireland there was an execution by drowning so lately as 1777.

Droylsden, a local board district in England, Lancashire, $3\frac{1}{2}$ miles E. Manchester, of which it is practically an outlying suburb. Pop. 8700.

Droz (drō), FRANÇOIS XAVIER JOSEPH, French moralist and historian; born at Besançon 1773, died 1850. In 1806 he published an *Essai sur l'Art d'être Heureux*, which was very popular; and in 1823 *De la Philosophie Morale, ou des Différents Systèmes sur la Science de la Vie*, which procured his admission into the Academy. His reputation is, however, founded chiefly on his *Histoire du Règne de Louis XVI.*

Droz (drō), PIERRE-JACQUET, Swiss mechanic, born at Chaux-de-Fonds in 1721, died 1790. Among his many contrivances were a compensation pendulum, a writing automaton, and an astronomical clock.—HENRI-LOUIS-JACQUET, son of the preceding, born 1752 at Chaux-de-Fonds, died at Naples 1791; followed the same line as his father, and constructed an automaton, representing a young female which played different tunes on the harpsichord; a pair of artificial hands for a young man who was mutilated, by means of which he was enabled to perform most of the necessary offices for himself.

Drugget, a coarse kind of woollen felt or cloth, formerly used by the lower classes for purposes of clothing, but now chiefly used as a covering for carpets.

Drugs, a general name for any substance, vegetable, animal, or mineral, used in the composition or preparation of medicines; also applied to ingredients used in chemical preparations employed in the arts.

Druids, the priests of the Celts of Gaul and Britain. According to Julius Cæsar they possessed the greatest authority among the Celtic nations. They had some knowledge of geometry, natural philosophy, &c., superintended the affairs of religion and morality, and performed the office of judges. They venerated the mistletoe when growing on the oak, a tree which they like-

wise esteemed sacred. They had a common superior, who was elected by a majority of votes from their own number, and who enjoyed his dignity for life. They took unusual care to fence themselves round with mysteries, and it is probable that they cherished doctrines unknown to the common people; but that they had a great secret philosophy which was handed down by oral tradition is very unlikely. Of their religious doctrines little is known.

Druids, THE ORDER OF, friendly societies which originated in a club of 'Druids' founded in London for mutual entertainment in 1780. They now form a great number of lodges or 'groves,' established for the mutual benefit of the members. They adopt a system of ceremonies professedly based on Druidical traditions. The order has extended to America, Australia, Germany, &c.

Drum, a musical instrument of percussion, of Eastern origin, either cylindrical or hemispherical in shape, with the end or ends covered with tightened parchment, which is stretched or slackened at pleasure by means of cords with sliding knots or screws. Drums are of three kinds: (1) the long or bass drum played with stuffed-nob drumsticks, and used only in large orchestras or military bands; (2) the side-drum, having two heads, the upper one only being played upon by two sticks of wood; (3) the kettle-drum, a hemisphere of brass or copper, the end of which is covered with parchment, always used in pairs, one drum being tuned to the key-note, and the other to the fifth of the key, the compass of the two together being an octave.

Drum, in machinery, a short cylinder revolving on an axis for the purpose of turning wheels or shafts, &c., by means of belts or bands passing round it.

Drumclog', a moorland tract in Lanarkshire, Scotland, 6 m. s.w. of Strathaven, the scene of a skirmish between Claverhouse and the Covenanters, in which the former was defeated (1679).

Drum-fish, DRUM, *Pogonias chromis*, and other species of the same genus, fishes found on the Atlantic coasts of N. America, and so named from the deep drumming sound they make in the water. They usually weigh about 20 lbs.

Drum-major, the title of the non-commissioned officer whose duty it is to teach and direct the drummers. He marches at the head of the band carrying the regimental baton.

Drum'mond, THOMAS, the inventor of the lime-ball light known by his name, was born at Edinburgh in October, 1797, and died at Dublin, April 15, 1840. He was educated at Edinburgh and at Woolwich, and entered the army as an engineer. In 1819 he became assistant to Colonel Colby in the trigonometrical survey of Great Britain and Ireland. He invented a heliostat, and first used the light which bears his name about 1825 during the survey of Ireland. He subsequently entered political life, and became in 1835 under-secretary for Ireland, a country which he practically ruled with the utmost success for five years.

Drummond, WILLIAM, of Hawthornden, a Scottish poet distinguished for the elegance and tenderness of his verses, was born at Hawthornden House, 7 miles from Edinburgh, 1585, died 1649. He was educated at the University of Edinburgh; after which he spent four years in foreign travels, residing for a part of the time at Bourges, to study the civil law. On his return to Scotland he retired to Hawthornden and gave himself up to the cultivation of poetry and polite literature, and here he spent the most of his life. He entertained Ben Jonson for three weeks on the occasion of a visit which the English dramatist made to Scotland in the winter of 1618-19, and took notes of Jonson's conversation, which were first published in 1711. He was the first Scottish writer to abandon the native dialect for the language raised to supremacy by the Elizabethan writers. His chief productions are: *The Cypress Grove*, in prose, containing reflections upon death; *Flowers of Zion, or Spiritual Poems*; *Tears on the Death of Mœliades* (that is, Prince Henry); *Poems, Amorous, Funeral, Divine, Pastoral*, in Sonnets, Songs, Sextains, Madrigals; *The River Forth Feasting* (on King James' Visit to Scotland in 1617); *Polemo-Middinia, or the Battle of the Dunhill*: a macaronic Poem; and *History of the Lives and Reigns of the Five Jameses, Kings of Scotland*. As a historian he is chiefly remarkable for an ornate style, and a strong attachment to the High Church principles of the Jacobites.

Drummond Light, a very intense light produced by turning two streams of gas, one of oxygen and the other of hydrogen, in a state of ignition upon a ball of lime. This light was proposed by Capt. Drummond (see above) to be employed in light-houses. See *Lime-light*.

Drunkeness, the state of being drunk or overpowered by alcoholic liquor, or the habit of indulging in intoxication. A similar condition may be produced by numerous agents, but the term is always applied to the act or habit of drinking alcoholics to excess. By the common law drunkeness is an offence against the public economy, and those found drunk are liable to fine or imprisonment. Drunkeness is no excuse for any crime, but it renders a contract invalid if either of the parties was in a state of complete drunkeness when the contract was signed.

Drunken Parliament, in Scottish history, a name given to the privy-council who, under their powers as representing the estates between sessions, met at Glasgow and passed an act (1st Oct. 1662) to remove the recusant ministers from their parishes within a month. All the members were said to have been drunk except Lockhart of Lee, who opposed the measure.

Drupa'ceæ, a name given by some botanists to that division of rosaceous plants which comprehends the peach, the cherry, the plum, and similar fruit-bearing trees.

Drupe, in botany, a stone fruit; a fruit in which the outer part of the pericarp becomes fleshy or softens like a berry while the inner hardens like a nut, forming a stone with a kernel, as the plum, cherry, apricot, and peach. The stone inclosing the kernel is called the *endocarp*, while the pulpy or succulent part is called the *mesocarp*. In some fruits, as those of the almond, the horse-chestnut, and cocoa-nut, the mesocarp is not succulent, yet, from their possessing the other qualities of the drupe, they receive the name. The date is a drupe in which the hard stone or endocarp is replaced by a membrane.

Drury Lane Theatre, one of the principal theatres in London, was established in the reign of James I. In 1671 it was burned down, and was rebuilt by Sir Christopher Wren between 1672 and 1674, but again consumed, Feb. 24, 1809. On this occasion it was rebuilt by B. Wyatt, and was reopened on the 10th of Oct. 1812, with an address composed by Lord Byron. It was in connection with this opening that James and Horace Smith wrote the *Rejected Addresses*. Nearly all the great English actors from Betterton and Garrick have been more or less connected with Drury Lane.

Druses, a curious people of mixed Syrian and Arabian origin, inhabiting the moun-

tains of Lebanon and Anti-Lebanon, in whose faith are combined the doctrines of the Pentateuch, part of the tenets of Christianity, the teachings of the Koran, and the Sufi allegories. They describe themselves as Unitarians and followers of Khalif Hakim Biamr-Allah, whom they regard as an incarnation of deity, the last prophet, and the founder of the true religion. They are nearly all taught to read and write; but are exceedingly turbulent, their conflicts with their neighbours the Maronites having often caused much trouble to the Turkish government. Their total number (exclusive of women and children) has been estimated at from 70,000 to 75,000.

Drusilla, a daughter of Herod Agrippa I., king of the Jews. She was born A.D. 38; married Azizus, king of Emesa, whom she divorced in order to marry Felix, procurator of Judea. She is thus the Drusilla who is mentioned in the Acts, and was probably present when Paul preached before Felix.

Drusus, the name of several distinguished Romans, among whom were:—**MARCUS LIVIUS**, orator and politician; became tribune of the people in 122 B.C. He opposed the policy of Caius Gracchus, and became popular by planting colonies.—**MARCUS LIVIUS**, son of the above, was early a strong champion of the senate or aristocratic party, but showed great skill in manipulating the mob. He rose to be tribune of the people, and was assassinated B.C. 91.—**NERO CLAUDIUS**, brother of the Emperor Tiberius, born B.C. 38. By a series of brilliant campaigns he extended the Roman empire to the German Ocean and the river Elbe, and was hence called *Germanicus*. By his wife Antonia, daughter of Mark Antony, he had a daughter, Livia, and two sons, Germanicus and Claudius, the latter of whom afterwards became emperor. He died in B.C. 9.

Dry'ads, wood nymphs, in the Greek mythology; supposed to be the tutelar deities of trees. Each particular tree or wood was the habitation of its own special dryad.

Dryan'der, **JONAS**, Swedish naturalist and pupil of Linnæus, born 1748, died 1810. He settled in England in 1782, and was connected with the Royal and Linnæan Societies till his death.

Dryan'dra, from the Swedish naturalist Dryander, a large genus of Australian shrubs, with hard, dry, evergreen, generally serrated leaves, and compact cylindrical clusters of yellow flowers, nat. order Proteaceæ. The species are esteemed by culti-

vators for the variety and peculiar forms of their leaves.

Dry'burgh Abbey, a monastic ruin in Scotland, consisting of the nave's western gable, the gable of the south transept, and a fragment of choir and north transept of an abbey founded in 1150 on the banks of the Tweed, about 5 miles E.S.E. of Melrose. It is celebrated as the burial-place of Sir Walter Scott and his family.

Dry'den, **JOHN**, English poet, was descended from an ancient family, his grandfather being Sir Erasmus Dryden of Canons Ashby, Northamptonshire. He was born near Aldwinkle, Northamptonshire, in 1631,



John Dryden.

and was admitted a king's scholar at Westminster under the celebrated Dr. Busby, whence he went to Trinity College, Cambridge, being here elected to a scholarship. After leaving the university he went to London, where he acted as secretary to his cousin Sir Gilbert Pickering, a favourite of Cromwell; and on the death of the Protector he wrote his Heroic Stanzas on that event. At the Restoration, however, he hailed the return of Charles II. in *Astræa Redux*, and from that time his devotion to the Stuarts knew no decay. In 1661 he produced his first play, *The Duke of Guise*; but the first that was performed was *The Wild Gallant*, which appeared in 1663 and was not a success. This was followed by *The Rival Ladies*, and *The Indian Queen*, a tragedy on Montezuma in heroic verse, written in collaboration with Sir Robert Howard, whose sister, Lady Elizabeth Howard, Dryden married in 1663. He followed up *The Indian Queen* with *The Indian Emperor*,

which at once raised Dryden to the highest pitch of public estimation, an elevation which he retained till his death. The great fire of London put a stop for some time to theatrical exhibitions. In the interval Dryden published the *Annus Mirabilis*, an historical account of the events of the year 1666, one of the most elaborate of his productions. In 1668 he also published his celebrated *Essay on Dramatic Poesy*—the first attempt to regulate dramatic writing. In 1668 the *Maiden Queen*, a tragi-comedy, was represented. This was followed in 1670 by the *Tempest*, an alteration from Shakspeare, in which he was assisted by Sir William Davenant. It was received with general applause, notwithstanding the very questionable taste and propriety of the added characters. Dryden was shortly afterwards appointed to the offices of royal historiographer and poet-laureate, with a salary of £200 a year. He now became professionally a writer for the stage, and produced many pieces, some of which have been strongly censured for their licentiousness and want of good taste. The first of his political and poetical satires, *Absalom and Achitophel* (Monmouth and Shaftesbury), was produced in 1681, and was followed by *The Medal*, a satire against sedition; and *Mac Flecknoe*, a satire on the poet Shadwell. On the accession of James in 1685 Dryden became a Roman Catholic, a conversion the sincerity of which has been not unreasonably regarded with suspicion, considering the time at which it occurred. At court the new convert was received with open arms, a considerable addition was made to his pension, and he defended his new religion at the expense of the old one in a poem, *The Hind and the Panther*. Among his other services to the new king were a savage reply to an attack by Stillingfleet, and panegyrics on Charles and James under the title of *Britannia Rediviva*. At the Revolution Dryden was deprived of the offices of poet-laureate and historiographer, and of the certain income which these offices secured him. During the remaining ten years of his life he produced some of his best work, including his admirable translations from the classics. He published, in conjunction with Congreve, Creech, and others, a translation of *Juvenal*, and one of *Persius* entirely by himself. About a third part of *Juvenal* was translated by Dryden, who wrote an essay on satire which was prefixed to the whole. His poetic translation of *Virgil* appeared in 1697, and, soon after,

that masterpiece of lyric poetry, *Alexander's Feast*, his *Fables*, &c. He died May 1st, 1700, in the sixty-ninth year of his age, and was buried in Westminster Abbey. Dryden is unequalled as a satirist among English poets, and the best of his tragedies are unsurpassed by any since written. His poetry as a whole is more remarkable for vigour and energy than beauty, but he did much to improve English verse. He was also an admirable prose writer. Personally he was modest and kindly. The whole of his works, edited by Sir W. Scott, were published in 1818 (18 vols. 8vo); they were recently republished with additional notes, &c., by George Saintsbury.

Drying-machine, a machine used in bleaching, dyeing, and laundry establishments, consisting of two concentric drums or cylinders, one within the other, open at the top, and having the inner cylinder perforated at its side with numerous small holes. The goods to be dried are placed within the inner cylinder, and the machine is then made to rotate with great velocity, when, by the action of centrifugal force, the water escapes through the holes in the side. The action of the drying-machine is the same in principle as that witnessed when a person trundles a mop to dry it.

Drying-oil, the name given to linseed and other oils which have been heated with oxide of lead; they are the bases of many paints and varnishes. When exposed to the air they absorb oxygen, and are converted into a transparent, tough, dry mass or varnish.

Dryobal'anops. See *Camphor*.

Dry'ophis, a genus of non-venomous tree serpents.

Dry Pile, a form of the ordinary voltaic pile, in which the liquid is replaced by some hygrometric substance, as paper which has been moistened with sugar and water and allowed to dry, chiefly useful in the construction of electroscopes of great delicacy.

Dry-point, a sharp-pointed instrument used by engravers to incise fine lines in copper without the plate being covered with etching-ground or the lines bit in by acid. This tool is much employed in working the more delicate portions of plates produced as etchings.

Dry-rot, a well-known disease affecting timber, occasioned by various species of fungi, the mycelium of which penetrates the timber, destroying it. *Polyporus hybridus* is the dry-rot of oak-built ships; *Merulius*

lacrymans is the most common and most formidable dry-rot fungus in Britain, found chiefly in fir-wood; while *Polyporus destructor* has the same pre-eminence in Germany.

Damp, unventilated situations are most favourable to the development of dry-rot fungi. Various methods have been proposed for the prevention of dry-rot; that most in favour is thoroughly saturating the wood with creosote, which makes the wood unfit for vegetation.

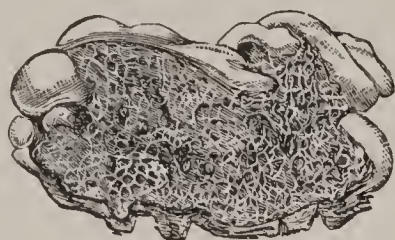

Dry-rot Fungus (*Merulius lacrymans*).

Dual, in grammar, that number which is used, in some languages, to designate two things, whilst another number (the plural) exists to express many. The Greek, Sanskrit, and Gothic of ancient languages, and the Lithuanian and Arabic of modern, possess forms of the verb and noun in which two persons or things are denoted, called the *dual* numbers.

Du'alism, the philosophical exposition of the nature of things by the hypothesis of two dissimilar primitive principles not derived from each other. Dualism in religion is chiefly confined to the adoption of a belief in two fundamental beings, a good and an evil one, as is done in some oriental religions, especially that of Zoroaster. In metaphysics, dualism is the doctrine of those who maintain the existence of spirit and matter as distinct substances, in opposition to idealism, which maintains we have no knowledge or assurance of the existence of anything but our own ideas or sensations. Dualism may correspond with realism in maintaining that our ideas of things are true transcripts of the originals, or rather of the qualities inherent in them, the spirit acting as a mirror and reflecting their true images; or it may hold that, although produced by outward objects, we have no assurance that in reality these at all correspond to our ideas of them, or even that they produce the same idea in two different minds.

Dubar'ry, MARIE JEANNE, COMTESSE, mistress of Louis XV., was born at Vaucouleurs 1746. She came young to Paris, entered on an immoral course, and was presented to the king in 1769, who had her married for form's sake to the Count du Barry. She exercised a powerful influence at court, and

with some of her confidants completely ruled the king. Important offices and privileges were in her gift, and the courtiers abased themselves before her. After the death of Louis she was dismissed from court and sent to live in a convent near Meaux. She received a pension from Louis XVI. During the reign of terror she was arrested as a royalist and executed, Nov. 1793.

Du Bartas, GUILLAUME DE SALLUSTE, SIEUR. See *Bartas*.

Dubit'za, a fortified town of Bosnia, on the right bank of the Unna, about 10 miles from its confluence with the Save. In the 16th and 17th centuries it was a frequent point of contention between Austria and Turkey. In 1878, with the rest of Bosnia, it passed under Austrian administration. Pop. 6000. On the opposite bank of the Unna, in Croatia, stands Austrian Dubitza, with upwards of 3000 inhabitants.

Dub'lin, the metropolis of Ireland, is situated in co. Dublin, on the east coast of the island, at the mouth of the Liffey, the banks of which for more than two miles from the sea are lined with quays. The river, which divides the city into two unequal parts, is crossed by numerous bridges. In the old part of the city the streets are irregular, narrow, and filthy; in the more modern and aristocratic quarters there are fine streets, squares, and terraces, but with little pretension to architectural merit. The public buildings, however, are especially numerous and handsome. The main thoroughfare, east to west, is by the magnificent quays along the Liffey. The principal street at right angles to the river is Sackville Street, a splendid street 650 yards long and 40 yards wide, forming a thoroughfare which is continued across the river by O'Connell Bridge, a magnificent structure the same width as Sackville Street. The principal public secular buildings are the Castle, the official residence of the viceroy; the Bank of Ireland, formerly the Irish parliament house; Trinity College; the courts of justice; the custom-house; the King's Inns; the post-office; rotunda; corn exchange; commercial buildings; the mansion house; city hall or corporation buildings; &c. The most important literary and scientific institutions are Trinity College (Dublin University); the Royal University; the Royal College of Science; the Roman Catholic University; the College of Surgeons; the Royal Dublin Society; the Royal Hibernian Academy of Painting, Sculpture, and Archi-



Sackville Street, Dublin, from the O'Connell Bridge, showing prominently the O'Connell Monument, the Post-office, and the Nelson Monument.

ecture; the Royal Irish Academy for Promoting the Study of Science, Literature, and Antiquities; the Archæological Society; the Royal Zoological Society; &c. Dublin contains two Protestant Episcopal cathedrals—St. Patrick's Cathedral, erected in 1190, and thoroughly restored between 1860 and 1865; and Christ's Church, built in 1038 and also recently restored, both restorations being carried on by private munificence. The Roman Catholic Cathedral is a very large edifice. The charitable institutions are numerous and some of them possess splendid buildings. There are several extensive military and constabulary barracks in the city and vicinity. A little north-west of the city, up the Liffey, is the Phoenix Park, with an area of 1759 acres. In it are the Viceregal Lodge, the residence of the Lord Lieutenant; the chief secretary's and under secretary's official residences; the Royal Hibernian Military School, and the depot of the Royal Irish Constabulary; as also the gardens of the Royal Zoological Society. The manufactures carried on are of little note: poplins, for which Dublin has been long celebrated, are still in some request, and brewing and distilling are largely carried on. Dublin returns four members to the House of Commons. It is an ancient town, but its early history is obscure. It was held by the Danes for more than three centuries from 836. Pop. 254,709.—The county, which is in the province of Leinster, on the east coast of the island, has an area of 226,895 acres, or 354 square miles, about a third of it under crops of various kinds, chiefly grass and clover. The surface on the whole is flat, but the ground rises at its southern boundary into a range of hills, the highest of which—Kippure—is 2473 feet above the sea. There is about 70 miles of sea-coast, the chief indentation being Dublin Bay. The principal stream is the Liffey, which intersects the county w. to e. Important water communications are the Royal and the Grand Canals, both centering in Dublin, and uniting the Liffey with the Shannon. The manufactures are unimportant, but the fisheries are extensive. The county returns two members to the House of Commons. Pop. 1891, 429,111.

Dublin, UNIVERSITY OF, an institution founded in 1591, when a charter, or letters-patent, was granted by Queen Elizabeth for the incorporation of the 'College of the Holy and Undivided Trinity,' the University and Trinity College being practically

the same. The corporation now consists of a provost, seven senior fellows, twenty-six junior fellows, and seventy foundation scholars. The senate of the university consists of 'the chancellor of the university, or, in his absence, of the vice-chancellor, and such doctors or masters of the university as shall have and keep their names on the books of Trinity College.' The senate possesses the right of electing the chancellor of the university; it is also the body which grants degrees. The fellows are appointed for life, after an examination. The scholars are chosen from among the undergraduates, after an examination in mathematics and logic, or in Greek, Latin, and logic. The scholarships are tenable for five years, or till the degree of M.A. is attained. The course of general instruction extends over four years. The academical year is divided into three terms—Hilary, Trinity, and Michaelmas term, and every student must keep at least two terms in each year in order to obtain a degree. The system of instruction is superintended by the fellows, both junior and senior, together with a large staff of professors in the various departments of science and literature. Eighteen of the junior fellows act as tutors, and every student must place himself under one of these on entering the college. The subjects necessary to a B.A. degree are, in the first year, mathematics, Greek, Latin; in the second year, mathematics, logic and metaphysics, Greek, Latin; in the third year, logic and metaphysics, physics, Greek, Latin; and in the fourth, astronomy, ethics, mathematical and experimental physics, classics. There are also a law school, a medical school, and a school of engineering, and degrees are granted in these subjects, as well as in arts and divinity. The college possesses a library of about 200,000 printed volumes and 1700 manuscripts. It has also a botanic garden and museum. In 1613 James I. granted to the university the right of returning two members to Parliament. One was taken away at the Union, but was restored by the reform bill of 1832. The number of students is usually about 1300.

Dubnit'za, a town in Bulgaria, 25 m. s.s.w. of Sofia. It has extensive iron-works, and some manufactures of silk. Pop. 7497.

Dubno, a town, European Russia, government of Volhynia. It was a place of some importance before the annexation of Western Poland by Russia. Pop. 7600.

Dubois (dü-bwä), GUILLAUME, a French cardinal, was the son of an apothecary; born in 1656, died 1723. He became tutor to the Duke of Chartres, afterwards Duke of Orleans and regent, and maintained his influence by pandering to the vices of his pupil. He became privy-councillor and overseer of the duke's household, and minister for foreign affairs under the regency. The archbishopric of Cambrai having become vacant, Dubois ventured to request it of the regent, although he was not even a priest. The regent was astonished at his boldness; but he obtained the post, having in one morning received all the clerical orders, and, a few days after, the archbishopric. By his consummate address he obtained a cardinal's hat, and in 1721 was appointed prime-minister. Dubois was an avaricious, lying, licentious creature, yet clever and industrious, and able to make himself very agreeable where it suited his interest.

Dubois (dü-bwä), PAUL, French sculptor, born 1829. He first studied law, but in 1856-58 gave himself up to sculpture under Toussaint at Paris, and then went to Italy, where the sculptors of the early Renaissance, Donatello, Luca Della Robbia, &c., had a decided influence upon him. Among his works are a St. John, a Narcissus, a Madonna and Child, Eve Awakening to Life, a figure of Song for the opera-house at Paris, and numerous busts: but his greatest work is the monument of General Lamoricière in the Cathedral of Nantes, with figures of Military Courage, Charity, Faith, and Meditation, which rank among the best products of French plastic art.

Dubois, Clearfield co., Pa. Pop. 6149.

Du Bois-Reymond (dü bwä-rā-mōn), Emil, German physiologist, and an especial authority on animal electricity, born at Berlin 1818. He studied theology, geology, and latterly anatomy and physiology, and became professor of physiology in the University of Berlin in 1858. His principal publication is *Researches in Animal Electricity*.

Dubossa'ri, a town of South Russia, gov. of Kherson, on the Dniester, 100 miles N.W. of Odessa. Pop. 8000.

Dubov'ka, a town of South Russia, gov. of Saratov, on the Volga; has an extensive river trade in wool, iron, oil, grain, &c. Pop. 12,737.

Dubuque (du-būk'), a city of Iowa, United States, on the right bank of the Mississippi. It occupies an important commercial posi-

tion as a railway centre and entrepôt for the agricultural and mineral products of the northern half of Iowa, and the timber of Wisconsin, and also from the valuable lead-mines in its vicinity. Pop. 30,311.

Ducange (dü-känzh), CHARLES DUFRESNE, SIEUR, a French historian and linguist, was born in 1610 near Amiens, died at Paris 1688. He studied in the Jesuits' College at Amiens, afterwards at Orleans and Paris. At this last place he became parliamentary advocate in 1631, and in 1645 royal treasurer at Amiens, from which place he was driven by a pestilence, in 1668, to Paris. Here he devoted himself entirely to literature, and published his great works, viz. his Glossaries of the Greek and Latin peculiar to the Middle Ages and the Moderns; his *Historia Byzantina*; the *Annals of Zonaras*; the *Numismatics of the Middle Ages*; and other important works.

Ducas, MICHAEL, Byzantine historian, flourished in the 15th century. His *Historia Byzantina*, which contains a reliable account of the siege and sack of Constantinople, was largely used by Gibbon.

Duc'at, a coin formerly common in several European states, especially in Italy, Austria, and Russia. They were either of silver or gold; average value of the former, 75 cts. to \$1.00, and of the latter about \$2.32. It was named from being first coined in one of the Italian duchies—Lat. *ducatius*, a duchy.

Ducatoon', formerly a Dutch silver coin worth 3 gulden 3 stivers, or \$1.30. There were coins of the same name in Italy. In Tuscany its value was about \$1.35, in Savoy slightly more, and in Venice about \$1.18.

Du Chaillu (dü-shā-yü), PAUL BELLONI, traveller, born in Paris 1835. He spent his youth in the French settlement at the Gaboon, on the west coast of Africa, where his father was a merchant. In 1852 he went to the United States, of which he afterwards became a naturalized citizen. In 1855 he began his first journey through Western Africa, and spent till 1859 alone among the different tribes, travelling on foot upwards of 8000 miles. He collected several gorillas, never before hunted, and rarely, if ever, before seen by any European. The result of this journey was published in 1861. A second expedition was made in 1863, an account of which, under the title *A Journey to Ashango Land*, appeared in 1867. The *Land of the Midnight Sun*, an account of a tour in Northern Europe (1881), had a

considerable success. He has also published a number of books intended for youth, and based on his travels. His latest work is *The Viking Age*, a treatise on the ancestors of the English-speaking peoples.

Duchesne, or DU CHESNE (dù-shān), ANDRÉ, French historian, born in 1584, died in 1640. His most important works are his collection of French historians—*Historiæ Francorum Scriptores*; *Historiæ Normannorum Scriptores 838-1220*; *Histoire d'Angleterre, d'Écosse et d'Irlande*; *Histoire des Papes*.

Duchn (dùhn). See *Dukhn*.

Duchoborzi (dùh-o-bor'tsē), a Russian sect of religious mystics which came first into notice in the 18th century. They hold that human souls existed before the creation of the world, and fell in that former existence. Their doctrinal system is, however, not well known; but their ethical teachings have a striking resemblance to those of the Quakers. They are now few in number.

Ducis (dü-sēs), JEAN FRANÇOIS, French dramatic writer, born at Versailles 1733, died 1816. Of his original works, the tragedy *Abufar* was much admired; but he is now best known for his adaptations of Shakspeare to the Parisian stage.

Duck, the name common to all the web-footed birds constituting the Linnæan genus *Anas*, now raised into a sub-family *Anatinæ*, and by some naturalists divided into two sub-families *Anatinæ* and *Fuligininæ*, or land-ducks and sea-ducks. The ducks are very numerous as species, and are met with all over the world. They are often migratory, going northward in summer to their breeding-places. Their food is partly vegetable, partly animal. The common mallard or wild-duck (*Anas Boschas*) is the original of the domestic duck. In its wild state the male is characterized by the deep green of the plumage of the head and neck, by a white collar separating the green from the dark chestnut of the lower part of the neck, and by having the four middle feathers of the tail recurved. The wild-duck is taken in large quantities by decoys and other means. Some tame ducks have nearly the same plumage as the wild ones; others vary greatly, being generally duller or pure white, but all the males have the four recurved tail-feathers. There are several favourite varieties of the domestic duck, those of Normandy and Picardy in France, and the Aylesbury ducks in England, being remarkable for their great size and delicacy of

flesh. The *musk-duck*, erroneously called *Muscovy duck* (*Cairina moschāta*), a native of South America, is the largest of the duck kind, and approaches nearly to the size of a goose. The *canvas-back duck* (which see) is peculiar to America, and is celebrated for the excellence of its flesh. Other species of ducks are the shoveller, remarkable for the strange form of its bill; the gadwall, which is more rare in America than in Europe; the pintail or sprigtail, remarkable for the form of its tail, abundant in both hemispheres; the black or dusky duck, peculiar to America, and very abundant; the summer or wood duck, remarkable for its great beauty, and for its migrations being directly opposed to those of the other species; the teal; the eider-duck, so well known for its valuable down; the scoter; the pochard or red-head; the scaup-duck or blue-bill; the long-tailed duck; the harlequin-duck, all found on both continents.

Duck, a species of coarse cloth made of flax, lighter and finer than canvas.

Duck-bill, or DUCK-MOLE. See *Ornithorhynchus*.

Ducking-stool, a stool or chair in which common scolds were formerly tied and plunged into water. They were of different forms, but that most commonly in use consisted of an upright post and a transverse movable beam on which the seat was fitted or from which it was suspended by a chain. The ducking-stool is mentioned in the Doomsday survey: it was extensively in use throughout the country from the 15th till the beginning of the 18th century, and in one rare case at least—at Leominster—was used as recently as 1809.

Duckweed, the popular name of several species of *Lemna*, nat. order Lemnaceæ, plants growing in ditches and shallow water, floating on the surface, and serving for food for ducks and geese. Five species are known in Britain, and others are common in America. They consist of small fronds bearing naked unisexual flowers.

Duckworth, SIR JOHN THOMAS, a British admiral, born in 1748, died 1817. He joined the navy when eleven years of age; and was post-captain in 1780. In 1793, on the breaking out of the French war, he was appointed to the command of the *Orion*, 74, forming part of the Channel fleet under Lord Howe, and distinguished himself in 1794 in the great naval victory gained by that celebrated admiral. In 1798 he aided in the capture of Minorca. From 1800 to 1806

he rendered important services on the West India station, in particular gaining a complete victory over a French squadron, for which he received a pension of £1000 a year and the thanks of both houses of parliament. In 1807, having been ordered to Constantinople, he forced the passage of the Dardanelles, but suffered severely from the Turkish batteries in returning. Between 1810 and 1813 he was governor of Newfoundland, in 1817 he was appointed to the chief command at Plymouth. In 1813 he was created a baronet.

Duclos (dù-klō), CHARLES PINOT, a French novelist, writer of memoirs, and grammarian, born in 1704 at Dinant, died at Paris 1772. He became secretary of the French Academy, and on the resignation of Voltaire he was appointed to the office of historiographer of France. His writings are lively and satirical. Among the best are *Confessions du Comte de B—* (1741); *Considérations sur les Mœurs de ce Siècle*; *Mémoires secrets sur les Règnes de Louis XIV. et XV.*; and *Remarques sur la Grammaire générale de Port-Royal*.

Ductility, the property of solid bodies, particularly metals, which renders them capable of being extended by drawing, while their thickness or diameter is diminished, without any actual fraction or separation of their parts. On this property the wire-drawing of metals depends. The following is nearly the order of ductility of the metals which possess the property in the highest degree, that of the first mentioned being the greatest: gold, silver, platinum, iron, copper, zinc, tin, lead, nickel, palladium, cadmium. Dr. Wollaston succeeded in obtaining a wire of platinum only $\frac{1}{30000}$ th of an inch in diameter. The ductility of glass at high temperatures seems to be unlimited, while its flexibility increases in proportion to the fineness to which its threads are drawn.

Duddon, an English river which flows 20 miles along the boundaries of Cumberland and Lancashire to the Irish Sea, and is the subject of a series of sonnets by Wordsworth, written in 1820.

Du Deffant, MADAME. See *Deffant*.

Duderstadt (dö'dér-stát), an old German town, prov. of Hanover, 10 miles east from Göttingen, formerly a member of the Hanseatic League and a place of some importance. Pop. 4350.

Dudevant (düd-vän), ARMANTINE-LUCILE-AURORE DUPIN, MADAME, better known by

the *nom de plume* of George Sand, one of the greatest of French novelists, born 1804, died 1876. She was the daughter of Maurice Dupin, an officer of the republican army, who was descended from a natural daughter of Marshal Saxe. Until the age of fourteen she was brought up at the Château of Nohant, near La Châtre (department of Indre), mostly under the care of her grandmother, afterwards spending nearly three years in an Augustinian convent in Paris. In 1822 she married Baron Dudevant, to whom she bore a son and a daughter; but in 1831 separated from him, and took up her residence in Paris. In conjunction with Jules Sandeau, a young lawyer, she wrote *Rose et Blanche*, which was published in 1831, with the pseudonym Jules Sand. The reception it met with afforded her an opportunity of publishing a novel solely by herself—*Indiana*, under the name of George Sand, which she ever after retained. *Indiana* had a brilliant success, but excited much criticism by its extreme views on social questions. This was also the case with many others of her works. *Valentine*, *Lélia*, *Jacques*, *André*, *Leone Leoni*, *Simon*, *Mauprat*, *La Dernière Aldini*, *Lavinia*, *Metella*, and others, appeared within the first few years after her *début*. She visited Italy with Alfred de Musset; and lived eight years with Frédéric-François Chopin, the composer. These relations also influenced or occasioned some of her works (as *Elle et Lui*, 1858). In 1836 she obtained a judicial separation from her husband, with the care of her children. She took an active interest in the revolution of 1848, and contributed considerably to newspaper and other political literature. In 1854 she published *Histoire de Ma Vie*, a psychological autobiography. Among her later novels are: *La Mare au Diable*; *François le Champi*; *La Petite Fadette*; *Jean*; *Teverino*; *La Filleule*; *Les Maîtres Sonneurs*; *L'Homme de Neige*; *Pierre qui Roule*; *Monsieur de Sylvestre*. Her published works consist of upwards of sixty separate novels, a large number of plays, and numerous articles in literary journals.—Her son MAURICE DUDEVANT, born at Paris 1825, has written several novels, &c., and has attained a certain reputation as an artist.

Dud'ley, a town of England, in an isolated part of Worcestershire inclosed by Staffordshire, 8 miles west by north of Birmingham. It is situated in the midst of the 'black country,' and has extensive coal-mines, iron-

mines, iron-works, and limestone quarries. It produces nails, chain-cables, anchors, vices, boilers, fire-irons, and has also glass-works, brick-works, brass-foundries, &c. There are the remains of a castle, said to have been founded in the 8th century by a Saxon prince called Dud, who has given the town its name. Dudley returns one member to parliament. Pop. of municipal borough, 45,740; of parliamentary borough, 90,223.

Dudley, SIR EDMUND, born 1642, executed 1510, noted in English history as an instrument of Henry VII. in the arbitrary acts of extortion by the revival of obsolete statutes and other unjust measures practised during the latter years of his reign. On the accession of Henry VIII. he was arrested for high treason, and perished on the scaffold with his associate Sir Richard Empson.

Dudley, LORD GUILDFORD, son of John, duke of Northumberland, was married in 1553 to Lady Jane Grey, whose claim to the throne the duke intended to assert on the death of Edward VI. On the failure of the plot Lord Guildford was condemned to death, but the sentence was not carried into effect till the insurrection of Wyatt induced Mary to order his immediate execution (1554).

Dudley, JOHN, Duke of Northumberland, son of Sir Edmund Dudley, minister of Henry VII.; was born in 1502, beheaded 1553. He was left by Henry VIII. one of the executors named in his will, as a kind of joint-regent during the minority of Edward VI. Under that prince he manifested the most insatiable ambition, and obtained vast accessions of honours, power, and emoluments. The illness of the king, over whom he had gained complete ascendancy, aroused his fears, and he endeavoured to strengthen his interest by marrying his son Lord Guildford Dudley to Lady Jane Grey, descended from the younger sister of Henry VIII., and persuaded Edward to settle the crown on his kinswoman by will, to the exclusion of his two sisters, the Princesses Mary and Elizabeth. The death of the king, the abortive attempts to place Lady Jane Grey on the throne, and the ruin of all those concerned in the scheme, are among the most familiar events in the annals of England.

Dudley, ROBERT, Earl of Leicester. See *Leicester*.

Dudley Limestone, a highly fossiliferous limestone belonging to the Silurian system,

occurring near Dudley, and equivalent to the Wenlock limestone. It abounds in beautiful masses of coral, shells, and trilobites.

Duel (from L. *duellum*, from *duo*, two), a premeditated and prearranged combat between two persons with deadly weapons, for the purpose of deciding some private difference or quarrel. The combat generally takes place in the presence of witnesses called seconds, who make arrangements as to the mode of fighting, place the weapons in the hands of the combatants, and see that the laws they have laid down are carried out. The origin of the practice of duelling is referred to the trial by 'wager of battle' which obtained in early ages. This form of duel arose among the Germanic peoples, and a judicial combat of the kind was authorized by Gundebald, king of the Burgundians, as early as 501 A.D. When the judicial combat declined the modern duel arose, being probably to some extent an independent outcome of the spirit and institutions of chivalry. France was the country in which it arose, the 16th century being the time at which it first became common. Upon every insult or injury which seemed to touch his honour, a gentleman thought himself entitled to draw his sword, and to call on his adversary to give him satisfaction, and it is calculated that 6000 persons fell in duels during ten years of the reign of Henry IV. His minister, Sully, remonstrated against the practice; but the king connived at it, supposing that it tended to maintain a military spirit among his people. In 1602, however, he issued a decree against it, and declared it to be punishable with death. Many subsequent prohibitions were issued, but they were all powerless to stop the practice. During the minority of Louis XIV. more than 4000 nobles are said to have lost their lives in duels. The practice of duelling was introduced into England from France in the reign of James I.; but it was never so common as in the latter country. Cromwell was an enemy of the duel, and during the protectorate there was a cessation of the practice. It came again into vogue, however, after the Restoration, thanks chiefly to the French ideas that then inundated the court. As society became more polished duels became more frequent, and they were never more numerous than in the reign of George III. Among the principals in the fatal duels of this period were Charles James Fox, Sheridan, Pitt, Canning, Castle-reagh, the Duke of York, the Duke of Rich-

mond, and Lord Canelford. The last-mentioned was the most notorious duellist of his time, and was himself killed in a duel in 1804. A duel was fought between the Duke of Wellington and Lord Winchelsea in 1829, but the practice was dying out. It lasted longest in the army. By English law fatal duelling is considered murder, no matter how fair the combat may have been, and the seconds are liable to the same penalty as the principals. In 1813 the principal and seconds in a fatal duel were sentenced to death, though afterwards pardoned. An officer in the army having anything to do with a duel renders himself liable to be cashiered. In France duelling still prevails to a certain extent; but the combats are usually very bloodless and ridiculous affairs. In the German army it is common, and is recognized by law. The duels of German students, so often spoken of, seldom cause serious bloodshed. In the United States duels are now uncommon. In some of the states the killing of a man in a duel is punishable by death or by forfeiture of political rights, and in a large number the sending of a challenge is a felony. In the army and navy it is forbidden. During the revolution there were a number of duels: Charles Lee was wounded by John Laurens; Gwinnett, a signer of the Declaration, was killed by Gen. McIntosh; Alexander Hamilton was slain by Aaron Burr. Decatur was killed and Barron wounded fighting a duel. Andrew Jackson killed Dickinson, and fought several other duels. Col. Benton killed Lucas, and had other encounters. Henry Clay and John Randolph fought in 1826. De Witt Clinton was a duellist.

Duen'na, an elderly female holding a middle station between a governess and companion, who takes charge of younger females in Spanish and Portuguese families.

Dufaure (dú-för), **JULES ARMAND STANISLAS**, French orator and statesman, born 1798, died 1881. In the Chamber of Deputies he became an influential leader of the Liberal party. Under the republic he was minister of the interior, but was driven from the public service by the coup-d'état of 1851. Under Thiers he acted as minister of justice; and in 1876, and again from 1877 to 1879, he was head of the cabinet.

Duff'erin, **FREDERICK TEMPLE HAMILTON-BLACKWOOD**, **MARQUIS OF**, British statesman and author, son of the fourth Baron Dufferin and a granddaughter of R. B. Sheridan, born at Florence 1826. He began his public ser-

vices in 1855, when he was attached to Earl Russell's mission to Vienna. Subsequently he was sent as commissioner to Syria in connection with the massacre of the Christians (1860); was under Indian secretary (1864-66); under secretary for war (1866); chancellor of the Duchy of Lancaster (1868-



Marquis of Dufferin and Ava

72); Governor-general of Canada (1872-78); ambassador at St. Petersburg (1879-81); at Constantinople (1882); sent to Cairo to settle the affairs of the country after Arabi Pasha's rebellion (1882-83); Viceroy of India (1884-88); British ambassador to Italy (1889). In addition to the celebrity he has attained as a brilliant diplomatist he is also a popular and successful author. In 1847 he published *Narrative of a Journey from Oxford to Skibbereen during the year of the Irish Famine*; in 1860, *Letters from High Latitudes*; and at various times pamphlets on Irish questions. In 1891 he was appointed ambassador at Paris.

Dufrenoy (dú-fré-nwä), **PIERRE ARMAND**, French geologist and mineralogist, born in 1792, died in 1857. He became latterly director of the school of mines, and published a great variety of papers on geology and mineralogy. In 1841 he published a great geological map of France with three volumes of text, and this was followed by his *Traité de Minéralogie*. He introduced a new classification of minerals, based on crystallography.

Dufresne (dù-frān). See *Ducange*.

Dufresny (dù-frā-nē), CHARLES RIVIÈRE, a French comic poet, born in 1648, died in 1724. He was clever and versatile, and had great skill as a landscape-gardener and an architectural designer. Among his dramatic pieces may be mentioned *L'Esprit de Contradiction*; *Le Mariage Fait et Rompu*; and *Le Double Veuvage*.

Dug'dale, SIR WILLIAM, an English antiquary, born in 1605 of a good family in Warwickshire, died 1686. He was made Chester herald in 1644; accompanied Charles I. through the civil war; and after the Restoration received knighthood, and was appointed garter king-at-arms. In concert with Roger Dodsworth he produced an important work on English monasteries titled *Monasticon Anglicanum*. Among his other works are *Antiquities of Warwickshire*; the *Baronage or Peerage of England*; *Origines Judiciales, or Historical Memoirs of the English Law, Courts of Justice, &c.*; a *History of St. Paul's Cathedral*; and various minor writings. He also completed and published the second volume of *Spelman's Concilia*.

Du'gong, a herbivorous mammal, the *Halicōrē dugong*, belonging to the order Sirenia, which includes the manatees. It is a native of the Indian seas; possesses a tapering body ending in a crescent-shaped



Dugong (*Halicore dugong*).

fin, and is said sometimes to attain a length of 20 feet, though generally it is about 7 or 8 feet in length. The skin is thick and smooth, with a few scattered bristles; the colour bluish above and white beneath. In its osteology it exhibits some points of correspondence with the *Pachydermata*. Its food consists of marine plants; it yields little or no oil, but is hunted by the Malays for its flesh, which resembles young beef, and is tender and palatable. A variety was discovered in the Red Sea by Rüppell, and called *Halicore tabernacūli*.

Duguay-Trouin (dü-gā-trō-aṅ), RENÉ, a

distinguished French seaman, born at St. Malo in 1673, died at Paris 1736. As commander of a privateer he took many prizes from the British between 1690 and 1697. He then entered the royal marine as a captain, and signalized himself so much in the Spanish war that the king granted him letters of nobility, in which it was stated that he had captured more than 300 merchant ships and twenty ships of war. By the capture of Rio de Janeiro (1711) he brought the crown more than 25,000,000 francs. Under Louis XV. he rendered important services in the Levant and the Mediterranean.

Du Guesclin (dü-gā-klan), BERTRAND, Constable of France, born about 1314, died 1380. Mainly to him must be attributed the expulsion of the English from Normandy, Guienne, and Poitou. He was captured by Chandos at the battle of Auray in 1364, and ransomed for 100,000 francs. While serving in Spain against Peter the Cruel he was made prisoner by the English Black Prince, but was soon liberated. For his services in Spain he was made Constable of Castile, Count of Trastamare, and Duke of Molinas; and in 1370 he was made Constable of France.

Duisburg (dö'is-burh), a flourishing town in Rhenish Prussia, 13 miles north of Düsseldorf. It is an ancient place, believed to be of Roman origin, early rose to be a free town, and became a member of the Hanseatic League. It possesses a beautiful church of the 15th century, and has iron manufactories, engineering works, chemical works, cotton and woollen mills, &c.; and a large trade greatly facilitated by a canal communicating with the Rhine, which is about 2 miles distant. Pop. 1890, 59,285.

Dujardin (dü-zhār-dan), KAREL, a Dutch artist, who excelled in painting landscapes, animals, and scenes in low life, born in 1640 at Amsterdam, died at Venice 1678. His paintings are rare, and command high prices.

Duke (French *duc*, Spanish *duque*, Italian *duca*, all from Latin *dux*, leader, commander), a title belonging originally to a military leader. In Britain it is a title of honour or nobility next below that of a prince or princess of the blood-royal, and that of archbishop of the Church of England. The first hereditary duke in England was the Black Prince, created by his father, Edward III., in 1336. The duchy of Cornwall was bestowed upon him, and was thenceforward attached to the eldest son of the king, who is considered a duke by birth. The duchy of

DUKE OF EXETER'S DAUGHTER — DULUTH.

Lancaster was soon after conferred on Edward's third son, John of Gaunt, and hence arose the special privileges which these two duchies still in part retain. A duke in the British peerage, not of royal rank, is styled 'your grace,' and is 'most noble;' his wife is a duchess. (See *Address, Forms of.*) The coronet consists of a richly-chased gold circle, having on its upper edge eight golden leaves of a conventional type called strawberry leaves; the cap of crimson velvet is closed at the top with a gold tassel, lined with sarsnet, and turned up with ermine. (See *Coronet.*) At various periods and in different continental countries the title duke (*Herzog* in Germany) has been given to the actual sovereigns of small states. The titles 'grand-duke' and 'grand-duchess,' 'archduke' and 'archduchess,' are in use also on the European continent, the latter to distinguish the princes and princesses of the Austrian imperial family. In the Bible the word *dukes* is used, Gen. xxxvi., for the *duces* of the Vulgate.

Duke of Exeter's Daughter, a rack in the Tower of London, so called after its inventor, a minister of Henry VI.

Dukhn (dūhn), a kind of millet (*Holcus spicatus* or *Pennisetum typhoides*), extensively cultivated in Egypt, also in Spain and elsewhere.

Dukinfield, or DUCKINFIELD, a township, England, county Chester, separated by the Tame from Ashton-under-Lyne, and mostly within Stalybridge parl. bor. Collieries, cotton factories, brick and tile works, give employment to the population. Pop. 1891, 17,408.

Dulcama'ra (L. *dulcis*, sweet, and *amārus*, bitter; lit. bitter-sweet), *Solanum Dulcamāra*, a common British hedge-plant, otherwise called bitter-sweet or woody nightshade. It is found from New England to Arkansas; its root being chewed gives a sensation of bitterness, then of sweetness.

Dulce (dul'sā), a lake of Guatemala, on the E. coast, communicating with the Gulf of Honduras by the lakelet el Golfete. It is about 30 miles long by 12 broad, and affords profitable turtle hunting.

Dulcigno (dul-chēn'yō), a small seaport town, formerly in Albania, now in the principality of Montenegro, on the Adriatic, the seat of a Roman Catholic bishop. Pop. 3000.

Dul'cimer, one of the most ancient musical instruments, used in almost all parts of the world. The modern instrument consists

of a shallow trapezium-shaped box without a top, across which runs a series of wires, tuned by pegs at the sides, and played on by being struck by two cork-headed hammers. It is in much less common use in

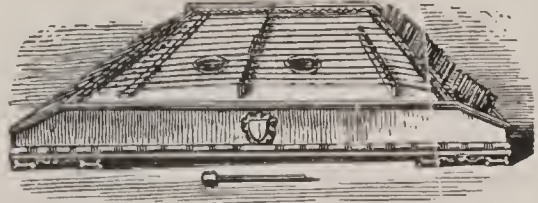

Italian Dulcimer.

Europe now than it was a century or two ago, and is interesting chiefly as being the prototype of the piano. It is still, however, occasionally to be met with on the Continent at rustic rejoicings, and in England in the hands of street musicians. The Hebrew psaltery is supposed to have been a variety of the dulcimer.

Dul'cinists, followers of Dulcinus, a layman of Lombardy, in the 14th century, who preached the reign of the Holy Ghost, affirming that the Father had reigned till Christ's incarnation, and that the Son's reign terminated in 1300. He was followed by a great many people to the Alps, where he and his wife were taken and burned by order of Clement IV.

Duli'a (Gr. *douleia*, service, from *doulos*, a slave), an inferior kind of worship or adoration, as that paid to saints and angels in the Roman Catholic Church. The Catholics recognize different degrees of worship. The lowest degree is the *dulia*, which is given to saints and angels. *Hyperdulia* is reserved for the Virgin alone; and *latria* is given to God and to each person in the Trinity.

Dulse, a sea-weed, the *Rhodomenia palmāta*, used in some parts of Scotland as an edible. It has a reddish-brown, or purple, leathery, veinless frond, several inches long, and is found at low water adhering to the rocks. It is an important plant to the Icelanders, and is stored by them in casks to be eaten with fish. In Kamtchatka a fermented liquor is made from it. In the south of England the name is given to the *Iridaea edulis*, also an edible sea-weed.

Duluth (du-luth'), a town of the U. States, capital of St. Louis co., Minnesota, at the s.w. extremity of Lake Superior. Five railroads, including Northern Pacific and St. Paul & Duluth, centre here; large docks and other works have been constructed

affording a convenient outlet for the surrounding wheat region. Pop. 33,115.

Dulwich (dul'ich), a village, England, county Surrey, 5 miles south of London Bridge (pop. 5500); noticeable chiefly on account of its college and schools, the former, called the College of God's Gift, founded as a charitable institution in 1619 by Edward Allen or Alleyn, a distinguished actor in the reigns of Elizabeth and James I. Four parishes are benefited by the charity: St. Luke's, Middlesex; St. Botolph's, Bishopgate; St. Saviour's, Southwark; and St. Giles', Camberwell. Having outlived its usefulness, in 1857 an act was passed by which the college was reconstituted. It now consists of two branches, the educational and the eleemosynary, between which the surplus revenue is divided in the proportion of three-fourths to the former and one-fourth to the latter. The educational branch comprises two schools, the upper and the lower; the former giving boys a high-class education (lower fees for those of the privileged parishes), and having a number of scholarships and exhibitions. The eleemosynary branch maintains a certain number of resident and non-resident poor people. The original revenues were only £800, but now amount to £17,000. Dulwich College is celebrated for its pictures, many of which were bequeathed by the founder; but the greater and more valuable portion of them were the bequest of Sir Francis Bourgeois, a landscape-painter, who died in 1810. The collection includes many fine pictures of the Dutch school.

Dumas (dü-mä), ALEXANDRE, French novelist and dramatist, born at Villers-Cotterets 1803. He was the son of a republican general, and grandson of Marquis de la Pailleterie and a negress, Tiennette Dumas. In 1823 he went to Paris, and obtained an assistant-secretaryship from the Duke of Orleans, afterwards Louis Philippe. He soon began to write for the stage, and in 1829 scored his first success with his drama *Henry III*. It was produced when the battle between the Romanticists and the Classicists was at its height, and hailed as a triumph by the former school. The same year appeared his *Christine*, and in quick succession *Antony*, *Richard d'Arlington*, *Tér'sa*, *Le Tour de Nesle*, *Catharine Howard*, *Mlle. de Belle-Isle*, &c. Dumas had now become a noted Parisian character. The critics fought over the merits of his pieces, and the scandal-

mongers over his prodigality and *galantries*. Turning his attention to romance, he produced a series of historical romances, among which may be mentioned, *Les Deux Dianas*; *La Reine Margot*; *Les Trois Mousquetaires*, with its continuations *Vingt Ans Après*,



Alexandre Dumas.

and *Vicomte de Bragelonne*. The *Monte-Cristo* and several others are also well known to English readers through translations. Several historical works were also written by him: *Louis XIV. et son Siècle*; *Le Regent et Louis XV.*; *Le Drame de '93*; *Florence et les Médicis*, &c. The works which bear his name amount to some 1200 volumes, including about 60 dramas; but the only claim he could lay to a great number of the productions issued under his name, was that he either sketched the plot or revised them before going to press. He earned vast sums of money, but his recklessness and extravagance latterly reduced him to the adoption of a shifty, scheming mode of living. His *Mémoires*, begun in 1852, present interesting sketches of literary life during the restoration, but display intense egotism. In 1860 he accompanied Garibaldi in the expedition which freed Naples from the Bourbons. He died at the residence of his son, at Puy, near Dieppe, in 1870.

Dumas, ALEXANDRE, son of the above, born 1824; novelist and dramatist. His works treat mostly of the relations between vice and morals. His first novels, *La Dame aux Camélias* and *Diane de Lys*, were very successful, as were also the plays which were founded on them. His dramas, which are much superior to his novels, deal satirically

with the characters, follies, and manners of French society.

Dumas, MATTHIEU, French soldier and military writer, born in 1753, died in Paris 1837. He early entered the French cavalry, took part in the war of North American independence, and was employed in the Levant and in Holland. At the commencement of the revolution he assisted Lafayette in organizing the national guard. On the triumph of the extreme party in 1797 Dumas was proscribed, but made his escape to Holstein, where he wrote the first part of his *Précis des Événements Militaires*, a valuable source for the history of the period of which it treats (1798–1807). He was recalled from exile by Napoleon, who had become first consul. His first employment was to organize the reserve for the army of Italy. In 1802 he was appointed state councillor; in 1805 he became general of division, and was shortly afterwards Neapolitan minister in the service of Joseph Bonaparte. In 1808 he was actively employed in the arrangements for the war against Austria, fought in the battles of Essling and Wagram, and arranged the terms of the armistice of Znaim. He held the office of general intendant of the army in the campaign of 1812. After the restoration Louis XVIII. appointed him councillor of state, and gave him several important appointments connected with the army. In 1830 he aided in bringing on the revolution of July, and after the fall of Charles X. he obtained the chief command of all the national guards of France, together with a peerage.

Du Maurier (dû-mō'ri-ā), **GEORGE LOUIS PALMELLA BUSSON**, artist and caricaturist, was born in Paris, 1834, but was a naturalized British subject. He went to England in 1851, and studied chemistry, but soon adopted art as a profession. After studying in Belgium and France he began to draw on wood for *Once a Week*, the *Cornhill Magazine*, &c. He subsequently joined the *Punch* staff, and became famous through his weekly drawings to that publication. He also illustrated a large number of books. "Trilby" created a sensation on its publication and gave him rank as an author. He also wrote the "Marsians." He died in 1897.

Dumb. See *Deaf and Dumb*.

Dumbar'ton, a royal and parliamentary burgh and seaport, Scotland, chief town of Dumbarton co., stands on the Leven near

its junction with the Clyde, 16 miles W.N.W. Glasgow. Ship-building is carried on to a great extent, and there are foundries, engineering works, &c. Dumbarton unites with Port-Glasgow, Renfrew, Rutherglen, and Kilmarnock in sending a member to parliament. Originally it was called Alcluyd, and it was the chief town of Cumbria or Strathclyde. Pop. 13,118. A little to the south is the famous rock and castle of Dumbarton, rising above the Clyde. The rock, which is of basalt, is 240 ft. in height, and about 1 mile in circumference at the base. It is one of the fortresses stipulated to be kept in repair by the Act of Union, and the barracks contain accommodation for 150 men. There has been a stronghold here from the earliest times, and the fortress of Dumbarton occupied an important place in Scottish history.—The county of Dumbarton is partly maritime, partly inland, consisting of two detached portions, the larger and most westerly lying between the Clyde, Loch Long, and Loch Lomond, and the far smaller portion being about 4 miles east from the former, and comprising only two parishes. More than half the area of the county is occupied by mountains, some of them attaining a height of upwards of 3000 feet. The lower lands are fertile, and in general well cultivated. More than one-half of Loch Lomond and fully two-thirds of the islands in it belong to Dumbartonshire. The Gareloch, an arm of the Firth of Clyde, forms a part of the county into a peninsula. The principal rivers are the Leven, from Loch Lomond, and the Kelvin, both belonging to the Clyde system. The chief minerals are coal, limestone, ironstone, and slate, all of which are wrought more or less. On the banks of the Leven and elsewhere are extensive cotton printing and bleaching establishments; and there are extensive ship-building yards along the Clyde. Besides Dumbarton, the chief town, the county contains the towns of Helensburgh and Kirkintilloch, and the manufacturing villages of Alexandria, Renton, and Bonhill. Vestiges of the Roman wall of Antoninus still exist. The county returns a member to the House of Commons. Pop. 1891, 94,511.

Dumb-bells, weights usually in the form of two iron balls connected by a straight piece for holding, used in gymnastic exercises for strengthening the muscles of the arms and chest.

Dumb-cane, a plant of the order Araceæ, the *Dieffenbachia seguina*, of the West

Indies, so called from its acridity causing swelling of the tongue when chewed, and destroying the power of speech.

Dumbness. See *Deaf and Dumb, Aphonia, Aphasia.*

Dumdum, a military village and extensive cantonment, Hindustan, province of Bengal, $4\frac{1}{2}$ miles E.N.E. Calcutta. The village is famous as being the scene of the first open manifestation of the Sepoys against the greased cartridges, which led to the mutiny of 1857. Pop. 4223.

Dumfries (dum-frēs'), a river port, railway centre, and parliamentary burgh, Scotland, capital of the county of same name, and the chief place in the south of Scotland; situated on the left bank of the Nith, about 6 miles from its junction with the Solway Firth. It is connected with the suburb Maxwelltown (in Kirkcudbright) by three bridges, one dating from the 13th century. It is a pleasing well-built town, with various handsome public edifices. There are iron-foundries, hosiery and tweed factories, tanneries, coach-building works, &c. The river Nith is navigable to the town for vessels of above 60 tons, but the port has decreased in importance since the development of the railway system. Dumfries is a place of great antiquity. The church of the Minorites which once stood here was the scene of the murder of the Red Comyn by Bruce in 1306. Burns spent his closing years here, and the street in which he lived now bears his name. His remains rest under a handsome mausoleum, and a statue of him was erected in 1882. Dumfries unites with Annan, Sanquhar, Lochmaben, and Kirkcudbright (the Dumfries burghs) in sending a member to parliament. Pop. 16,673.—The county abuts on the Solway Firth, having on its borders the counties of Lanark, Peebles, Selkirk, Roxburgh, Ayr, and Kirkcudbright; area about 1100 sq. miles or 702,946 acres, of which about a third are under cultivation. The surface is irregular, but for the most part mountainous, especially in the north and north-west districts, where the hills attain a considerable elevation, some of them exceeding 2000 ft. The dales of the Nith, Annan, and Esk, the chief rivers of the county, contain fine pasture holms and good arable land. Oats, potatoes, and turnips are the most common products. Good cattle are reared, and are much in request for the English market. The sheep on the hill pastures are mostly cheviots; on the

lower and arable lands the Leicester breed prevails. The minerals most abundant are coal, lead, iron, antimony, and gypsum. Coal and lead are worked to a small extent. Limestone and freestone abound in various parts. There are no manufactures worth mentioning. The county returns one member to the House of Commons. Its principal towns are Dumfries, Annan, Sanquhar, Lockerbie, Moffat, and Lochmaben. Pop. 1891, 74,308.

Dumont (dù-mōn), PIERRE ÉTIENNE LOUIS, the friend and literary assistant of Mirabeau and Jeremy Bentham, was born at Geneva in 1759, died at Milan 1829. He was ordained a minister of the Protestant church in 1781. He attached himself to the democratic party in Geneva, and when the opposite party gained the ascendancy he went to St. Petersburg, in 1782, where he was appointed pastor of the French Reformed Church. Soon after he accepted an offer to act as tutor to the sons of Lord Shelburne, afterwards Marquis of Lansdowne, which brought him to London, where he became intimate with Jeremy Bentham and Sir Samuel Romilly. Visiting Paris during the first years of the revolution he gained the friendship of Mirabeau, whom he assisted in the composition of speeches and reports, and of whom he wrote some interesting Recollections. On his return to London he formed that connection with Bentham which fixed his career as a writer; recasting, popularizing, and editing Bentham's works in a form suitable for the reading public. He returned to Geneva in 1814 and became a senator.

Dumont D'Urville (dù-mōn dūr-vēl), JULES SEBASTIEN CÉSAR, French navigator, was born in 1790, killed in a railway accident between Paris and Versailles 1842. After completing his studies at Caen he entered the French navy, in which he ultimately rose to be rear-admiral. In 1826-29 he commanded the corvette *Astrolabe*, which was sent to obtain tidings of La Pérouse, and to make hydrographic observations. He made surveys of the coasts of Australia, New Zealand, &c., and found remains of the shipwreck of La Pérouse on one of the Pacific islands. The result of this voyage was the publication of *Voyage de Découverte autour du Monde*. In 1837 he sailed with the *Astrolabe* and *Zéléé* on a voyage of Antarctic discovery, and after many dangers, and having visited many parts of Oceania, he returned in 1840. On his return

began the publication of *Voyage au Pôle sud et dans l'Océanie*, which was finished by one of his companions.

Dumouriez (dü-mö-ri-ā), CHARLES FRANÇOIS DUPERRIER, a French general of great military talent, was born at Cambrai in 1739 of a noble family of Provence, died near Henley-on-Thames 1823. He served as an



General Dumouriez.

officer in the Seven Years' war. In 1768 he went to Corsica as quartermaster-general of the small army which was sent for the conquest of that island, and was afterwards made colonel. In 1778 he was appointed governor of Cherbourg. At the revolution he joined the Jacobins, and subsequently the Girondists, and in 1792 he was minister of foreign affairs. War breaking out between France and Austria he resigned in order to take command of the army; invaded Flanders, and defeated the Austrians at Jemappes and conquered Belgium. Instead of prosecuting the war vigorously he now entered upon measures for the overthrow of the revolutionary government, issued a proclamation, in which he promised the restoration of the constitutional monarchy in the person of the heir to the crown, but was attacked by the Versailles volunteers, and compelled to flee (April 4, 1793). The convention set a price of 300,000 livres upon his head. At first he retired to Brussels, and after various wanderings found a final refuge in England. His *Memoirs*, written by himself, appeared in 1794; an enlarged edition in 1822. He was also the author of a large number of political pamphlets.

Düna (dü'ná), or WESTERN DVINA, a river of Russia, which rises in the government Tver, about 15 miles w. of the source of the Volga, falls into the Gulf of Riga, has a course of about 650 miles, and waters the seven governments of Tver, Pskoff, Vitebsk, Mogileff, Vilna, Courland, and Livonia, draining an area of about 65,000 sq. miles. It is navigable for a considerable distance, but is frozen for about four months each year.

Dünaburg (dü'na-bürg), or DVINABURG, a fortified town, Russia, government of Vitebsk, on the right bank of the Düna, or Dvina, 112 miles south-east from Riga. It carries on various industries, a considerable trade, and has three yearly fairs. Pop. 72,286.

Dünamünde (dü'ná-mün-de; 'Dünamouth'), a fortress and port of Russia, on the Gulf of Riga, at the mouth of the Düna, having a large winter harbour for the shipping of Riga.

Dunbar', a town of Scotland; a royal and municipal (formerly parl.) burgh and seaport in Haddingtonshire, at the mouth of the Firth of Forth. It is a place of great antiquity, having originated in a castle, once of great strength and importance, which underwent several memorable sieges, on one occasion being successfully defended against the English for nineteen weeks by Black Agnes, countess of Dunbar. In 1650 Cromwell totally defeated the Scottish army under David Leslie near the town. The harbour is not very commodious, but the town is an important fishing station. Pop. 3661.

Dunbar', WILLIAM, the most eminent of all the old Scottish poets, was born, probably in East Lothian, about 1460-65. In 1475 he went to St. Andrews, where, in 1477, he took the degree of B.A., and two years later that of M.A. After this he seems to have become a begging friar of the Franciscan order, and made journeys in England and France, but he returned to Scotland about 1490, and attached himself to the court of James IV., from whom he received a pension of £10. On the marriage of James IV. to Margaret of England Dunbar celebrated the event in a poem of great beauty, entitled, *The Thrissil and the Rois*. His pension was ultimately raised to £80 a year, and he was the recipient of various additional gratuities, though he appears frequently to have addressed both the king and the queen for a benefice, but

always without success. After Flodden his name disappears from the royal accounts, and he probably died about 1520. His works, which consist of elaborate allegories, satirical and grinly humorous pieces, and poems full of brilliant description and luxuriant imagination, were first collected by David Laing (Edin. 1834).

Dunblane', an old episcopal city, Scotland, in Perthshire, 6 miles north-east of Stirling, on the Allan. The ancient cathedral, partly in ruins, dates from the 12th century. The nave is 130 feet by 58 feet, and the choir, now the parish church, is 80 feet by 30 feet. The building is in process of being restored. Bishop Leighton held the see from 1662 to 1670. About two miles from the town the indecisive battle of Sherriffmuir was fought in 1715, between the royal forces under the Duke of Argyle, and the Jacobites under the Earl of Mar. Pop. 1899.

Dun'can, ADAM, VISCOUNT, a Scottish naval officer, was born in Dundee in 1731, died 1804. He went to sea when young, and was a post-captain in 1761. In the following year he served at the taking of Havana; and in 1779 he shared in the victory of Admiral Rodney over the Spaniards. In 1789 he became rear-admiral of the blue, and in 1794 vice-admiral of the white squadron. The following year he was appointed commander of the North Sea fleet, and in October, 1797, won a brilliant victory over the Dutch fleet off Camperdown, for which he was rewarded with the title of Viscount Duncan and a pension of £2000 a year.

Duncan, THOMAS, an eminent Scottish painter, was born in 1807, died at Edinburgh 1845. He studied under Sir W. Allan, and was elected an associate of the Royal Academy in 1843. His principal works were illustrative of Scottish history and character. Among the best known of them are: The Abdication of Mary Queen of Scots; Anne Page and Slender; Prince Charles Edward and the Highlanders entering Edinburgh after Prestonpans; Charles Edward asleep in a Cave after Culloden; The Martyrdom of John Brown of Priesthill; &c. His portraits are very highly esteemed.

Dun'cansby Head, a promontory in Caithness-shire, Scotland, forming the N.E. extremity of the Scottish mainland, $1\frac{3}{4}$ m. E. of John o' Groat's House, and $18\frac{1}{2}$ N. by E. of Wick. Close by the promontory are two insulated rocks, of fantastic form and great

height, called the Stacks of Duncansby, which in spring and summer are covered with sea-fowl.

Dun'ciad, The, a celebrated satirical poem by Pope, in which he gibbets his critics and foes. The first three books were published in 1728; the fourth book, or New Dunciad, appeared in 1742, with illustrations by Scriblerus and notes variorum. Cibber was latterly substituted for Theobald as the hero; and among others who figured in the satire were Ambrose Philips, Blackmore, Bentley, Defoe, Dennis, Shadwell, Settle, &c.

Dundalk (dun-dak'), a seaport and former parl. borough, Ireland, capital of the county of Louth, on Castletown River, about 2 miles above its mouth in Dundalk Bay. Its principal manufactures are ropes and castings; the trade, chiefly in cattle and agricultural produce, is extensive. Pop. 13,207.

Dundas' OF ARNISTON, the name of a family several members of which held a conspicuous place in the legal and political history of Scotland.—**SIR JAMES DUNDAS**, the first of Arniston, knighted by James VI., was the third son of George Dundas of Dundas, a descendant of the Dunbars, earls of March.—His eldest son, **SIR JAMES**, was member of parliament for Mid-Lothian, and was appointed one of the judges of the Court of Session (1662).—His eldest son **ROBERT** was also raised to the bench of the Court of Session, and filled that station for thirty-seven years. He died in 1727.—His eldest son **ROBERT** (1685–1753) was successively solicitor-general for Scotland, lord-advocate, member of parliament for the county of Edinburgh, and dean of the faculty of advocates. In 1737 he was raised to the bench, and on the death of Lord-president Forbes of Culloden, in 1748, he was appointed his successor. His eldest son **ROBERT** (1713–87) also attained to the positions of lord-advocate, and lord-president of the Court of Session.—His brother **HENRY DUNDAS, VISCOUNT MELVILLE**, distinguished statesman, born in 1741, died 1811. He obtained the post of solicitor-general in 1773, that of lord-advocate in 1775, and was made joint keeper of the signet for Scotland in 1777. In 1782 he was appointed treasurer of the navy and member of the privy-council; and from that time took a leading part in all the Pitt measures, and had supreme influence in Scotland. Among other offices he held that of first lord of the admiralty; and in 1805 he was impeached before the House of Lords of high crimes

and misdemeanours in his former office of treasurer of the navy, but was finally acquitted. He was created Viscount Melville in 1801, a title still borne by his direct descendant.

Dundee', a city, royal and parliamentary burgh, and seaport, Scotland, in the county of Forfar, on the north shore of the Firth of Tay, about 8 miles from the open sea, 37 miles N.N.E. of Edinburgh; in population the third town in Scotland. It stretches along the Tay, or east to west, and of late years has been greatly extended in both directions. The more recently formed streets are spacious and handsome, but most of those of more ancient date are narrow, and irregularly built. The most conspicuous building is St. Mary's Tower, or the Old Steeple as it is popularly called, 156 feet high, erected in the middle of the 14th century, and to which three modern parochial churches have been built in form of a cathedral, the nave, choir, and transept respectively forming a separate church. Among public buildings are: the town-hall, several public halls, the high school, exchange, infirmary, lunatic asylum, Albert Institute and free library, &c. The chief educational institution is the University College, for males and females, whose first session opened in 1883. It was founded by private munificence, receiving an endowment of £140,000, and has eight chairs, namely, mathematics and natural philosophy, chemistry, classics and ancient history, English language and literature and modern history, engineering and drawing, botany, anatomy, and biology. Dundee has several public parks and recreation grounds and a good supply of water. The town has long been celebrated for its textile manufactures, particularly those of the coarser descriptions of linen, and it is now the chief seat of the linen trade in Scotland and of the jute trade in Great Britain, there being a great number of mills and factories engaged in the spinning and weaving of flax, jute, and hemp. Ship-building is extensively carried on, and there are large engineering establishments, &c. Another branch of business is the northern seal and whale fishery. Dundee is also famous for its marmalade and other preserves and confectionery. The shipping accommodation includes five large wet-docks, with a connected tidal harbour and graving-docks. The chief foreign trade is with the Baltic and Archangel in the importation of flax and hemp, with Norway, Sweden, and Canada in tim-

ber, and with Calcutta in jute. The railway facilities of Dundee were greatly increased in 1878 by the opening of a bridge across the Tay; but on the 28th of December, 1879, the bridge was destroyed in a violent storm, when about 100 people in a train in the act of crossing lost their lives. A new bridge, to replace the one destroyed, was opened for traffic in June, 1887; it is a very substantial structure about two miles in length. Dundee was made a royal burgh by William the Lion, was twice in the possession of the English under Edward I., and was as often retaken by Wallace and Bruce. In 1645 it was besieged, taken, and sacked by the Duke of Montrose; and six years afterwards it was stormed by Monk, when a great number of its inhabitants were put to death. Since 1868 the town has returned two members to parliament. In 1888 it was raised by royal grant to the rank of a city. Pop. 1891, 155,640.

Dundee, JOHN GRAHAM OF CLAVERHOUSE, VISCOUNT. See *Graham*.

Dundon'ald, THOMAS COCHRANE, TENTH EARL OF, British admiral, was born in Lanarkshire 1775, died 1860. At the age of eighteen he embarked with his uncle, then Captain, and afterwards Sir Alexander Cochrane, in the *Hind*, of twenty-eight guns, and soon distinguished himself by his daring and gallantry. In 1800 he was appointed to the *Speedy* sloop-of-war of fourteen guns, and in the course of thirteen months captured over fifty vessels, but was at last captured himself. In 1805, while in command of the *Pallas* frigate, he took some rich prizes, and for the next four years in the *Impérieuse* performed remarkable exploits in cutting out vessels, storming batteries, destroying signals, &c. On his return to England he entered parliament, and by his attacks on the abuses of the naval administration made himself obnoxious to the authorities. He gave further offence by charging Lord Gambier, his superior officer, with neglect of duty (which was true); by denouncing the abuses of the prize-court, and the treatment of the prisoners of war. His enemies succeeded in 1814 in convicting him on a charge—since proved to be false—of originating a rumour, for speculative purposes, that Napoleon had abdicated. He was expelled from parliament, deprived of all his honours, imprisoned for a year, and fined £1000. The electors of Westminster immediately paid his fine and re-elected him, but he had to remain in prison till the

DUNEDIN — DUNGARVAN.

expiration of his sentence. In 1818 he took service in the Chilian navy, his exploits greatly aiding the national independence of that country, as well as soon after of Brazil. In 1832 he was restored to his rank in the British navy. In 1831, by the death of his father, he had succeeded to the name and title of Earl of Dundonald; in 1841 he became vice-admiral of the blue; in 1848 he was appointed commander-in-chief on the North America and West India station; and in 1851 and 1854 respectively he became vice-admiral of the white, and rear-admiral of the United Kingdom. He did much to promote the adoption of steam and the screw propeller in war-ships. He wrote an autobiography, which, though left incomplete, is a most interesting work.

Dunedin (dun-ē'din), capital of the provincial district of Otago, New Zealand, and the most important commercial town in the colony, stands at the upper extremity

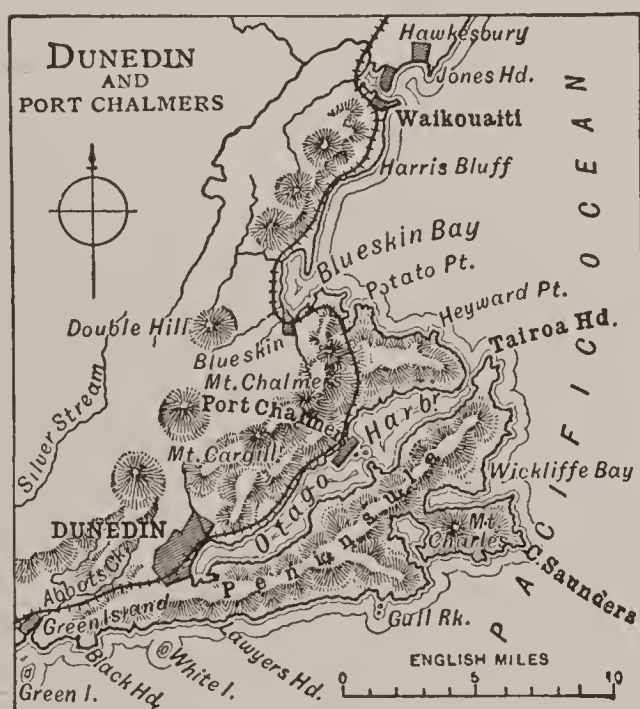

of an arm of the sea, about 9 miles from its port, Port Chalmers, with which it is connected by railway. Though founded in 1848, its more rapid progress dates only from 1861, when extensive gold-fields discovered in Otago attracted a large influx of population. It is well paved, lighted with gas, and has a good supply of water. There are many handsome buildings, both public and private: the municipal buildings, the post-office, hospital, lunatic asylum, government offices, the university, high schools (boys' and girls'), the new museum, several banks (especially the Bank of New Zealand),

the athenæum and mechanics' institute, the freemasons' hall, two theatres, &c. Wool is the staple export. Several woollen and other manufactories are now in existence. There is a regular line of steamers between this port and Melbourne, and communication is frequent with all parts of New Zealand. Through the opening of the new Victoria Channel from Port Chalmers vessels drawing 16 feet can now ascend to Dunedin at low water. Pop. of Dunedin proper in 1891, 22,376; including suburbs, 45,865.

Dunes, low hills of sand accumulated on the sea-coasts of Holland, Britain, Spain, and other countries, in some places encroaching on and covering what once was cultivated land, but in others serving as a natural barrier to protect the country from the destructive encroachments of the sea.

Dunferm'line, a royal and parliamentary burgh of Scotland, county of Fife, 3 miles N. of the Firth of Forth, and 13 north-west of Edinburgh. The streets though narrow are well built. Dunfermline was early a favourite residence of the kings of Scotland, and at it were born David II., James I., Charles I., and his sister Elizabeth. The Benedictine abbey founded by Malcolm Canmore (1070) is now represented chiefly by the Abbey Church, underneath the pulpit of which are the remains of King Robert Bruce. Dunfermline early took the lead in the manufacture of table-linen, and is still unrivalled by any other town in the kingdom. There are collieries in the neighbourhood. Pop. 1891, 22,365.

Dun-fish, a name in the U. States for cod cured by being split open, partially salted, piled up in a dark place under salt-grass or hay, and then closely packed: named from their dun colour.

Dungan'on, a town of Ireland, county Tyrone, 35 miles west by south of Belfast. It has manufactures of linen and earthenware. Till 1885 it returned a member to the House of Commons. Pop. 4084.

Dungarpur (dön-gar-pör'), an Indian native state in Rajputána; area, 1000 sq. m.; pop. 153,381.—DUNGARPUR is also the name of the chief town and residence of the Maharawal of the state.

Dungar'van, a seaport of Ireland, county Waterford, on the Bay of Dungarvan, much resorted to for sea-bathing. The harbour is shallow, and the trade depends almost entirely on agricultural produce. Till 1885 it returned a member to parliament. Pop. 7391.

DUNG BEETLE — DUNOIS.

Dung Beetle, a name applied to a large number of coleopterous insects of the Lamellicorn family (or that family in which the antennæ terminate usually in lateral leaflets) from their habit of burying their eggs in dung. The *Geotrūpes stercorarius*, 'dor' or 'shard-borne' beetle, and the *Scarabæus sacer*, or sacred beetle of the Egyptians, are examples.

Dungeness (dunj-nes'), a low headland on the s. coast of Kent, 10½ m. s.e. of Rye; has a lighthouse with fixed light.

Dunkeld', a small town of Scotland, on the Tay, about 14 miles north by west from Perth; pop. 768. It is a very ancient place, and from 850, when Kenneth I. removed the remains of St. Columba from Iona to a church which he had built here, became the metropolitan see of Scotland, till supplanted by St. Andrews. The choir of the ancient cathedral is still used as the parish church. Near it is Dunkeld House, the seat of the Duke of Athol, the grounds of which are the finest and most extensive in Scotland.

Dunkers, or TUNKERS, a religious sect in America, founded in Schwartzenu, Germany, in 1708, and which takes its name from the Ger. *tunken*, to dip, from their mode of baptizing converts. They reject infant baptism; use great plainness of dress and language; refuse to take oaths or to fight; and anoint the sick with oil in order to their recovery, depending on this unction and prayer, and rejecting the use of medicine. Every brother is allowed to speak in the congregation, and their best speaker is usually set apart as their minister. By census of 1890 they number 72,190 members.

Dunkirk' (French, *Dunkerque*), a seaport town, France, department Nord, at the entrance of the Strait of Dover, surrounded by walls, and otherwise defended by forts and outworks. It has several fine churches, a college, a public library, and a gallery of paintings; manufactures of earthenware, leather, soap, starch, ropes; sugar-refineries, breweries, distilleries, &c. Pop. 39,498.

Dunkirk, Chautauqua co., N. Y., on Lake Erie; a port of entry 35 miles s. w. of Buffalo, connected by rail with oil regions of Pennsylvania. Pop. 1890, 9416.

Dun'lin, a British bird (*Tringa variabilis*), a species of sandpiper, occurring in vast flocks along sandy shores. It is about 8 inches in length from the point of the bill to the extremity of the tail, and its plumage undergoes marked variations in summer and winter, the back passing from black with

reddish edges to each feather, to an ashen gray, and the breast from mottled black to pure white. The American *Tringa alpina*

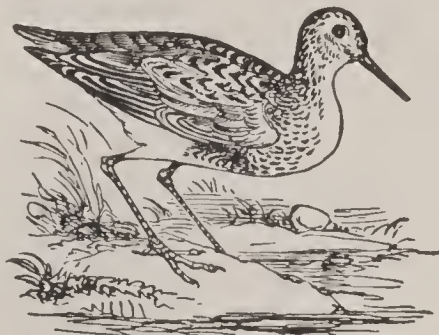

Dunlin (*Tringa variabilis*).

is a frequent visitor to Scotland, and there is some ground for believing that these large birds are only varieties of the dunlin.

Dunlop', a parish of Ayrshire, Scotland, which has given its name to an esteemed variety of cheese.

Dunmow', GREAT and LITTLE, two villages, England, county of Essex. The latter is remarkable for the ancient custom, recently revived, of giving a fitch of bacon to any couple who, a year and a day after their marriage, could swear that they had neither quarrelled nor repented.

Dunmore, a town in the United States, in Lackawanna county, State of Pennsylvania, 2 miles from Scranton. It derives its prosperity chiefly from the anthracite coal-mines which are worked in the vicinity. Pop. 1890, 8315.

Dunnet Head, a bold rock promontory in Caithness, with sandstone cliffs 100 to 300 feet high, the most northerly point of the mainland of Scotland, crowned by a light house visible at a distance of 25 miles.

Dunnot'tar Castle, an extensive ruin on the coast of Kincardineshire, Scotland, on a precipitous rock rising from the sea. It dates from the close of the 14th century, and was long the stronghold of the Keiths, earls marischal. During the Commonwealth this castle was selected for the preservation of the Scottish regalia; and in 1685 it was used as a state prison for Covenanters. It was dismantled in 1720.

Dunois (dü-nwä), JEAN, Count of Orleans and of Longueville; a French hero, natural son of Louis, duke of Orleans, born 1402, died 1468. Dunois made the name 'Bastard of Orleans' illustrious by his military exploits. He began his career with the defeat of Warwick and Suffolk, whom he pursued to Paris. Being besieged by the English he defended Orleans until relieved

by the Maid of Orleans. In 1450 he had completely freed France from the English, and was rewarded by the title of 'deliverer of his country,' the county of Longueville, and the dignity of high chamberlain of France.

Dunoon', a watering-place of Scotland, in Argyleshire, on the shore of the Firth of Clyde, 27 miles by river from Glasgow. The town extends for about 3 miles s.s.w. from the Holy Loch, and consists of Hunter's Quay to the N., Kirn and Dunoon proper to the S.; each with its separate steam-boat pier. On a green rocky knoll are remains of the castle of Dunoon, once a residence of the family of Argyle. Pop. 4692.

Dunquerque (dūn-kerk). See *Dunkirk*.

Duns, DUNSE (dunz, duns), a town in Berwickshire, Scotland, on the Whitadder; has manufactures of linen, paper-mills, &c. Pop. 2437. On Duns Law (700 feet) are traces of a camp formed by Leslie's Covenanters in 1639.

Duns, JOHN, commonly called *Duns Scotus*, an eminent scholastic divine, born 1265 or 1275, but whether in England, Scotland, or Ireland is uncertain. He was admitted when young into an institution belonging to the Franciscan friars at Newcastle, whence he was sent to Merton College, Oxford. In 1301 he was appointed divinity professor at Oxford, and the fame of his learning and talents drew crowds of scholars from all parts. In 1304 he went to Paris, and was appointed professor and regent in the theological schools, in which situation he acquired the title of 'the subtle doctor.' Duns opposed Thomas Aquinas on the subject of grace and free-will; and hence the *Scotists* are opposed to the *Thomists*. Duns was the apostle of realism, which was opposed to the systems of nominalism and conceptualism promulgated by the other sections into which the schoolmen were divided. He died, it is said, at Cologne in 1308, leaving behind him numerous works.

Dunsin'ane, a hill in Scotland, one of the Sidlaws, alt. 1012 feet, about 7 miles N.E. of Perth, with vestiges of a hill-fort locally called Macbeth's Castle.

Dun'stable, a town, England, county of Bedford, 32 miles north-west of London. It was an important Roman station, and had a palace and a priory founded by Henry I. Part of the latter is used as the parish church. Dunstable is famous for its manufactures of straw-plait. Pop. 4627.

Dun'stan, St., an Anglo-Saxon divine and

statesman, was born at Glastonbury in 925, died at Canterbury 988. As a youth he was remarkable for his learning and his skill in music, painting, carving, and working in metals. He entered the Benedictine order, became an anchorite at Glastonbury, and in 945 was made abbot by King Edmund. After the death of Edmund, Edred, the next king, made him his prime-minister and principal director in civil and ecclesiastical affairs. In the reign of Edwy he was banished, but was recalled by Edgar, and made Archbishop of Canterbury. He was again deprived of power on the accession of Ethelred in 978, and devoted the last years of his life to his diocese and the literary and artistic pursuits of his earlier days. He did much to improve education and to raise the standing and character of the priesthood. The old biographies of him have all a large legendary element.

Duodecimal System, in numeration, a system of numbers the scale of which is twelve. *Duodecimals* is a term applied to an arithmetical method of ascertaining the number of square feet, &c., in a rectangular area or surface, whose sides are given in feet, inches, and lines.

Duodec'imo (often contracted *12mo*) is that form of volume in which each leaf forms a twelfth part of the sheet.

Duode'num, the commencement of the intestinal canal, the first of the smaller intestines, so called because its length is about twelve fingers' breadth (Lat. *duodeni*, by twelves).

Dupanloup (dū-pān-lō), FELIX ANTOINE PHILIBERT, French prelate, born at St. Felix, in Savoy, 1802; became a French subject by naturalization in 1838; died at Paris 1878. He was ordained in 1825, appointed professor of theology at the Sorbonne in 1841, and Bishop of Orleans in 1849. From that time he took a prominent part in all the political and religious discussions in France. He belonged to the Gallican party, but submitted to the decisions of the council of the Vatican; and was a strenuous advocate for free education.

Dupleix (dū-plā), JOSEPH, a French leader in India, born 1697, died 1763. He accumulated a fortune by commercial operations in India, and in 1742 was appointed Governor of Pondicherry for the French East India Company. He formed the project of founding a French Empire in India, and soon made himself master of the Carnatic partly by conquest and partly by poli-

tical intrigue. He was opposed by Clive, and a long string of British successes caused the complete overthrow of all his plans.

Dupont (dù-pōn), PIERRE, French songwriter, was born at Lyons 1821, died at St. Étienne (Loire) 1870. He was educated by his godfather, a priest, and began to write and compose songs at an early age. After issuing a volume of poems in 1844 he went to Paris and obtained a place in the office of the secretary of the Institute. Some of his songs, such as Song of Bread and Song of the Workers, had a Socialistic ring which proved obnoxious to the government which came into power in December, 1852. He was arrested, imprisoned, and condemned to be banished for seven years; but his release was soon procured. His poems have been collected under the titles Cahiers de Chansons, La Muse Populaire, Chants et Chansons, Poésie et Musique, Études littéraires, &c.

Dupont de Nemours (dù-pōn dé nè-mör), PIERRE SAMUEL, French political economist, born at Paris, December 1739; died in America 1817. He early gained a reputation for his writings on commerce and political economy, and was employed by Turgot and Vergennes in the public service. During the ministry of Calonne he became councillor of state, and in 1787 was secretary to the Assembly of the Notables. He was twice president of the National Assembly. During the revolution he opposed the extreme republicans, and escaped the guillotine narrowly at the downfall of Robespierre. From 1798 to 1802 he was in America, and on his return to France he refused all public office. He finally returned to America in 1815. Among his writings are Philosophie de l'Univers, Vie de Turgot, and a translation of Ariosto.

Düppel (dùp'l), a fortified village in the province of Schleswig, Prussia, on the coast of the Little Belt. The place is of considerable strategical importance, and has been the scene of some severe struggles between the Danes, to whom it formerly belonged, and the Germans. It was captured by the Prussians in 1864, after a siege and bombardment which lasted nearly two months.

Dupuytren (dù-pü-i-trän), GUILLAUME, BARON, French surgeon and anatomist; born in 1777, died at Paris 1835. He became in 1803 second, and in 1815 first surgeon to the Hôtel Dieu, Paris. The professorship of surgery to the medical faculty, conferred upon him in 1813, was exchanged in 1818

for a clinical lectureship in the above hospital. In 1823 he was appointed first physician to Louis XVIII., and retained the same situation under Charles X. He was considered the first French surgeon of his day; he made important discoveries in morbid anatomy, and invented several useful surgical instruments.

Duquesne (dù-kān), ABRAHAM, French admiral; born 1610, died 1688. In his seventeenth year he was in the sea-fight off Rochelle, and distinguished himself during and after the year 1637 in the war against Spain. In 1647 he commanded the expedition against Naples. In the Sicilian war he thrice defeated the combined fleets of Holland and Spain, under the renowned De Ruyter. After he had reduced Algiers and Genoa Louis XIV. conferred upon him the fine estate of Bouchet, and made it a marquise, with the title of Duquesne. He was a Protestant and the only person exempted from the banishment of his sect, occasioned by the repeal of the edict of Nantes.

Dura Mater. See *Brain*.

Dura'men, the name given by botanists to the central wood or heart-wood in the trunk of an exogenous tree. It is more solid than the newer wood that surrounds it, from the formation of secondary layers of cellulose in the wood cells.

Durance (dù-rāns), a river of France, which rises in the Cottian Alps, and after a course of about 180 miles joins the Rhone about 4 miles below Avignon. Marseilles is supplied with water from the Durance.

Duran'go, a town in Mexico, capital of the state of Durango, about 500 miles N.W. Mexico, on an elevation 6845 feet above the sea. It is well built, has a cathedral, a mint, manufactures of cotton and woollen goods, leather, &c. Pop. 12,000.—The state (area, 42,530 sq. miles) is partly mountainous and unproductive, but has valuable gold, silver, and iron mines, and also fertile tracts. Pop. 265,931.

Durango, capital La Plata co., Col., on the Las Animas river and D. & R. G. Rwy. Pop. (1890) 2726.

Durante (dö-rān'tā), FRANCESCO, Italian musician, born 1684, died 1755. He attained a high degree of eminence in vocal church music, and he trained the most celebrated musical masters of the eighteenth century in Naples—Pergolese, Sacchini, Piccini, Guglielmi, Jomelli, &c.

Durazzo (dö-rät'sō; anc. *Dyrrhachium* or *Epidamnus*), a seaport, European Turkey.

Dur'ban, or PORT NATAL, the chief port of the colony of Natal, S. Africa. The town is well laid out, and carries on a considerable trade, being connected by railway with Maritzburg and the interior, but the harbour has a bad entrance, though recently improved. Durban was founded in 1834, and named after Sir Benjamin D'Urban, governor of the Cape. Pop. 1891, 25,512.

Durbar (dūr-bār'), an audience-room in the palaces of the native princes of India; hence, a general reception by a ruler in British India or by any officer of rank.

Durbhangah. See *Darbhangah*.

Düren (dü'ren), a town, Rhenish Prussia, on the right bank of the Roer, 16 miles E. by N. of Aix-la-Chapelle. It has important manufactures of woollens, paper, leather, rails, hardware, &c., and an extensive trade. Pop. 19,802.

Dürer (dü'rér), ALBERT, German painter, designer, sculptor, and engraver on wood and metal, born at Nürnberg 1471, died there 1528. His father was a skilful goldsmith of Hungary. In 1486 he left his



Albert Dürer.

father's trade and became an apprentice of Michael Wohlgemuth, then the best painter in Nürnberg. Having finished his studies he entered upon his 'wanderjahre,' the usual course of travels of a German youth. On his return to Nürnberg he married the daughter of Hans Frey, a mechanic, who has been falsely accused for centuries of embittering his life and bringing him to his grave. In 1505 he went to Venice to improve himself in his art. His abilities excited envy and admiration. He painted the Martyrdom of Bartholomew for St. Mark's church, which painting was pur-

chased by the Emperor Rudolph and removed to Prague. He also travelled to Bologna, to improve his knowledge of perspective. On his return to Nürnberg his fame spread far and wide. Maximilian I. appointed him his court-painter, and Charles V. confirmed him in this office. All the artists and learned men of his time honoured and loved him, and for many years he was one of the chief burghers of his native town. Profound application and great facility in the mechanical part of his art were the characteristics of Dürer, and enabled him to exert a great influence on German art. He was the first in Germany who taught the rules of perspective, and of the proportions of the human figure. He not only made use of the burin, like his predecessors, but was also among the first to practice etching. He invented the method of printing woodcuts with two colours. Among his masterpieces in painting are a Crucifixion, Adam and Eve, an Adoration of the Magi, and portraits of Raphael, Erasmus, and Melanchthon, who were his friends. Among his best engravings on copper are his Fortune, Melancholy, Adam and Eve in Paradise, St. Hubert, St. Jerome, and the Smaller Passion (so called), in sixteen plates. Among his best engravings on wood are the Greater Passion (so called), in thirteen plates; the Smaller Passion, with the frontispiece, thirty-seven pieces; the Revelation of St. John, with the frontispiece, fifteen plates; the Life of Mary, two prints, with the frontispiece. Dürer has also much merit as a writer, and published works on Human Proportion, Fortification, and the Use of the Compass and Square.

Du'ress, in law, restraint or compulsion, is of two kinds: *duress of imprisonment*, which is imprisonment or restraint of personal liberty; and *duress by menaces or threats* (*per minas*), when a person is threatened with loss of life, or with some kind of injury. An act done under duress is voidable or excusable.

D'Urfey (dur'fi), THOMAS, an English poet and wit, the grandson of a French Protestant refugee, was born at Exeter in 1653, and died in 1723. He abandoned law for literature, and wrote a large number of comedies of a licentious character. D'Urfey's name is now principally remembered in connection with his Pills to Purge Melancholy, a collection of songs and ballads, partly his own, and many of them coarse or licentious. His society was generally courted by the

witty, and he enjoyed the favour of four successive monarchs.

Durga (dur'gä), a Hindu divinity, one of the names given to the consort of Siva. She is generally represented with ten arms. In one hand she holds a spear, with which



Durga.

she is piercing Mahisha, the chief of the demons, the killing of whom was her most famous exploit; in another a sword; in a third the hair of the demon chief; and in others, the trident, discus, axe, club, and shield. A great festival in her honour, the *Durga puja*, is celebrated annually, lasting for ten days.

Durham (du'ram), an ancient city and parliamentary borough in England, capital of the county of the same name, on the river Wear, which is crossed here by four bridges, 14 miles s. of Newcastle. The principal public buildings are the ancient castle—now appropriated to the uses of the university—the cathedral, and other churches, the town-hall, county prison, grammar-school, &c. The educational institutions comprise the university, the grammar-school, a training-school for schoolmistresses, and other schools. There are manufactures of carpeting and mustard. The cathedral occupies a height overlooking the Wear. The larger portion of it is Norman in style, with insertions in all the English styles. Three magnificent and elaborately ornamented towers spring up from the body of the building, one from the centre 212 feet high, and two together from the west end each 143 feet high; the entire

length is 420 feet. It was founded by William de Carlepho, assisted by Malcolm, king of Scotland, in 1093. Durham returns one member to the House of Commons. Pop. 14,863.—**DURHAM UNIVERSITY** was founded in 1832, opened in 1833, incorporated by royal charter in 1837. It is in some relations connected with the bishopric of Durham, the office of warden being annexed to the deanery of Durham, and a canonry in the cathedral being annexed to each of the professors of divinity and classical literature. There are also professors of mathematics, Hebrew, and medicine. The students mostly reside within the university buildings, but in 1870 a regulation was passed dispensing with the necessity of residing in any college, hall, or house connected with the university in order to be admitted as a member. The management of the university is intrusted, under the Bishop of Durham as visitor, to the dean and chapter of the cathedral as governors, and to the warden, senate, and convocation, the latter including all persons regularly admitted since the opening of the university to the degrees of Doctor in Divinity, Civil Law, and Medicine, and to the degree of Master of Arts. The academical year is divided into three terms—Michaelmas, Epiphany, and Easter. For the degree of B.A., or a license in theology, a residence of two years (of six months each) is necessary. The M.A. degree may be obtained by a graduate who is of the standing of nine terms since taking his degree of B.A. There are a college of physical science and a college of medicine at Newcastle-on-Tyne in connection with the university.—The county is on the N.E. coast of England, having on the E. the German Ocean, on the N. Northumberland, from which it is divided by the rivers Tyne and Derwent, Cumberland on the W., and Yorkshire on the S., the river Tees parting the two counties. Its area is 647,592 acres, of which two-thirds are under cultivation. The western portion of the county is hilly, inclosing fertile valleys, the eastern portion is more level, and the centre contains extensive coal-fields. Lead, iron, and millstones are also produced. The chief corn crops are wheat and oats; the chief green crops turnips and potatoes. The cattle are esteemed both for the dairy and for fattening. In connection with the commerce of the county may be noticed its foundries, iron-works, potteries, glass-houses, iron-shipbuilding, engine and machine works,

chemical works, &c. For parliamentary purposes it is divided into eight divisions, each of which sends one member to the House of Commons. Pop. 1891, 1,016,449.

Durham, Orange co., N. C., 26 m. N. W. Raleigh. It has snuff and tobacco factories. Gen. Johnston surrendered here, April 25, 1865. Pop. 5485.

Durham, BOOK OF, a Latin text of the gospels written by Bishop Eadfrith of Lindisfarne, with an interlinear Saxon gloss, finished in the year 720; now in the British Museum.

Durham, SIMEON OF, English chronicler of the 12th century; wrote Annals of England to the reign of Henry I., particularly valuable for events connected with the N. of England. They were continued by John of Hexham.

Durian, or DURION (*Durio zibethinus*), a large and lofty tree growing in the Malayan Archipelago. The largish flowers, of a yellow-green colour, are produced on the stem or main branches, and are followed by the large fetid fruit, which is of the size of a man's head, and is a favourite food of the natives during the time (May and June) when it is in season. There is usually a second crop in November. The smell is offensive, like putrid animal matter, but with this is associated the most delicious flavour, which places it, notwithstanding the odour, in the opinion of many, in the foremost place among tropical fruits.



Durian (*Durio zibethinus*).

Dürkheim (dürk'hīm), an old town in Rhenish Bavaria (the Palatinate), 14 miles w.s.w. of Mannheim, well known for its mineral water. Pop. 6111.

Durlach (dūr'läh), a town in Baden, 4 miles E.S.E. of Karlsruhe, at the foot of the Thurmberg, on which is an old Roman watch-tower. Pop. 7655.

Durmast, a species of oak, *Quercus sessiliflora*, or according to some, *Q. pubescens*, so closely allied to the common oak (*Q. Robur*) as to be reckoned only a variety of it. Its wood is, however, darker, heavier, and more elastic, less easy to split, not so easy to break, yet the least difficult to bend. It is highly

valued, therefore, by the builder and cabinet-maker.

Duroc (dù-rok), MICHEL GÉRARD CHRISTOPHE, Duke of Friuli, a distinguished general under Bonaparte, was born at Pont-à-Mousson in 1772; killed, 1813, at the battle of Bautzen. He served as aide-de-camp to Napoleon in the Italian and Egyptian campaigns. In 1805 he was made grand-marshal of the palace; and was frequently employed in diplomatic missions, though he still took his full share in the wars of France till the time of his death. He was a great favourite of Napoleon, and was killed by his side.

Durra. See *Dhurra*.

Dürrenstein (dūr'en-stīn), a village in Lower Austria, on the Danube, 41 miles west by north of Vienna. Here are the ruins of the castle in which Leopold, Duke of Austria, imprisoned Richard Cœur-de-Lion on his return from Palestine, 1192.

Duruy (dù-rü-ē), VICTOR, French historian and educationalist, born at Paris 1811. He was appointed successively teacher of history in the gymnasium of Henry IV., then at the Normal School and the Polytechnic School, inspector of the Academy of Paris, inspector-general of secondary education, and minister of public instruction (1863-69). He is author of *Géographie Politique de la République Romaine et de l'Empire*; *Géographie Historique du Moyen Age*; *Histoire Romaine*; *Histoire de France*; *Histoire Grecque*; *Histoire Populaire Contemporaine*; &c. Some of these are simply school-books, but his *Histoire des Romains* (translated into English) and his *Histoire de la Grèce Ancienne* (translated into English) are extensive and important works, the former especially. He died Nov. 25, 1894.

Düsseldorf (düs'sel-dorf), a town of Prussia, in the Rhenish province, beautifully situated among villas and gardens on the right bank of the Rhine, 22 miles N.N.W. Cologne, one of the handsomest towns in the valley of the Rhine. It is a great focus of railway and steamboat communication, and has a number of handsome public buildings, and several remarkable churches. Among the public institutions particular notice is due to the Academy of Art, founded, 1767, by the Elector Theodore, and afterwards directed by Cornelius, Schadow, Bendemann, &c. It has the honour of having founded a school of painting, which takes the name of Düsseldorf, and has had a large number of distinguished pupils. The indus-

tries embrace iron, cotton, leather, tobacco, carpets, chemicals, objects of art, &c., and the trade is large. Pop. 1890, 144,682.

Dust-brand. See *Smut*.

Dutch, the people and language of Holland or the Netherlands. See *Netherlands*.

Dutch Auction, a kind of auction in which articles are put up at a high price and lowered till a bidder is met with.

Dutch Clover, *Trifolium repens*, commonly called white clover, a valuable pasture plant. It has a creeping stem; the leaflets are broad, obovate, with a horse-shoe mark in the centre; the white or pinkish flowers are in a globular head.

Dutch Gold, an alloy of eleven parts of copper and two of zinc. Called also *Pinchbeck*. See also *Dutch Metal*.

Dutch Metal, an alloy containing 84·5–84·7 p. ct. of copper and 15·5–15·3 p. ct. of zinc, with a fine golden-yellow colour, ductile, malleable, and tenacious. When beaten out by a process analogous to that for gold-leaf, until the sheets are less than 1–50,000th part of an inch thick, it constitutes Dutch leaf or Dutch foil, and is used instead of gold-leaf for ornamental purposes.

Dutch Oven, a cooking chamber of tin-plate suspended in front of a fire, and used chiefly for roasting meat.

Dutch Pink, a bright yellow colour used in distemper, for staining paper-hangings, and for other ordinary purposes. It is composed of chalk or whiting coloured with a decoction of birch leaves, French berries, and alum.

Dutch Rush, *Equisetum hyemale*, one of the plants known as horse-tails, with a firm texture and so large an amount of silex in the cuticle that it is employed as a fine sand-paper for polishing delicate woodwork. The plant is found in marshes and woods in Britain, but for economical use it is imported from Holland, whence its popular name. It is sparingly found in the U. S.

Dutch Tears, a name for Prince Rupert's drops.

Dutrochet (dù-tro-shā), RENÉ JOACHIM HENRI, a French physiologist, born in Poitou in 1776, died at Paris in 1847. He served for some time as medical attendant to Joseph Bonaparte during the Spanish campaign 1808–9; but latterly he returned to France, and retired to the estate of Châteaurenault, where he devoted himself exclusively to physical and physiological studies. His chief works have been published in a collective form with the title

Mémoires pour servir à l'Histoire Anatomique et Physiologique des Végétaux et des Animaux (1837, two vols.).

Dutteeah, or DATTIYA. See *Datia*.

Duykerbok (doi'kér-bok), *Cephalolophus mugens*, a small S. African antelope with short horns (none in the female) and a tuft of stiff hairs between them.

Dvina, NORTHERN. See *Dvina*.

Dvina, WESTERN. See *Dvina*.

Dvorak (dvor-shäk'), ANTON, a Bohemian musical composer, born in 1841. He studied at the Prague Conservatoire and at Vienna. He has composed several operas on national Bohemian subjects, a number of songs, orchestral arrangements of Bohemian dances, several symphonies, a *Stabat Mater*, a cantata (*The Spectre Bride*), and an oratorio (*St. Ludmilla*). His works are well known and popular in England.

Dwale, a name of the deadly nightshade. See *Nightshade*.

Dwarf, a term applied to any animal or plant greatly below the usual size of its kind, particularly to a human being of small dimensions. Accounts of dwarf tribes have been common from early times, such tribes being located especially in Africa; and it would appear from the accounts of Du Chaillu, Schweinfurth, and other travellers that there are several dwarfish tribes throughout this continent. The Obongo, a race of dwarfs, are described as living in woods near the Okanda river, in wretched huts made of branches. Other races are the Mabongo, and the Akka dwarfs of Central Africa (see *Akkas*); and a race is said to exist in the Congo State, not as a distinct community, however, but mixed with other tribes. Individual dwarfs occur in all races, and were formerly a fashionable appendage to the courts of princes and the families of nobles. Jeffery Hudson, the favourite dwarf of Charles I., at the age of thirty is said to have been only 18 inches high, though he afterwards grew to 3 feet 9 inches. Bébé, the celebrated dwarf of Stanislas of Poland, was 33 inches; Wybrand Lolkes, a Dutch dwarf, when sixty years of age was only 27 inches; Charles H. Stratton, 'General Tom Thumb,' was 31 inches high at the age of twenty-five; Francis Flynn, 'General Mite,' was only 21 inches at sixteen.

Dwarfing, the process of training up trees or shrubs for ornament in houses so as to cause them never to reach more than a very small size, by keeping them in poor soil, giving them little water, pinching off strong

shoots, &c. Practised among the Chinese and Japanese.

Dwight (dwit), TIMOTHY, American divine, born in Massachusetts 1752, died 1817. His father was Colonel Timothy Dwight, and his mother was a daughter of Jonathan Edwards. He served as chaplain in the revolutionary army, and ultimately became president of Yale College. His *Theology* (1818) was for long a standard both in Britain and in America. He was also the author of two poems, the *Conquest of Canaan* and *Greenfield Hill*, besides numerous unimportant works, consisting of dissertations, occasional sermons, &c.

Dwina, NORTHERN, a Russian river formed by the union of two small streams in the government of Vologda. It flows in a north-westerly direction, and falls by four mouths into the White Sea. At Archangel, before it divides itself, it is 4 miles broad. It is navigable as far as Suchona, and is connected with the Volga by canal.

Dwina, WESTERN. See *Düna*.

Dy'ad (Greek, *dyas*, the number two), in chem., an elementary substance, each atom of which in combining with other bodies is equivalent to two atoms of hydrogen.

Dy'aks, the aborigines of Borneo, chiefly inhabiting the interior of the island. They are a finely-formed race, of a yellow complexion, and are described as docile, industrious, and superior to the Malays. The more advanced of them practise agriculture and dwell in neatly-constructed and tolerably comfortable houses. In Sarawak they have made considerable advances in civilization. They are mostly heathens. The practice of head-hunting (hunting their enemies to make trophies of their heads) is practised among them, but has been abolished where European influence prevails. See *Borneo*.

Dyas, in geology, a name for the Permian system.

Dyaus (dyous), the god of the sky in the older mythology of the Hindus. His name is etymologically connected with that of the Greek Zeus.

Dyce (dis), ALEXANDER, Shakespearian editor, born at Edinburgh June 30, 1798, died May 15, 1869. He was educated at Edinburgh and Oxford, but in 1827 settled in London, where most of his life was passed. He first became known by his editions of Collins, Peele, Webster, Marlowe, Skelton, &c., accompanied by notes and biographies of the authors. In 1840 he founded

the Percy Society for the publication of ancient comedies and ballads. His chief work, however, was an edition of Shakespeare in six volumes, with notes, &c. (1853-58).

Dyce, WILLIAM, a historical painter, born at Aberdeen in 1806; died near London 1864. He studied at Edinburgh and at Rome, and finally settled in London, on being appointed in 1838 head of the government school of design, Somerset House. He was elected a Royal Academician in 1848. Amongst his chief works are *Francesca da Rimini* (1837); *Joash shooting the Arrow of Deliverance* (1844); *King Lear in the Storm* (1851); *Christabel* (1855); *The Good Shepherd* (1856); the *Baptism of Ethelbert*, a large fresco for the Houses of Parliament, and a series of frescoes illustrative of the legends relating to King Arthur, for the same.

Dyck, SIR ANTHONY VAN. See *Vandyck*.

Dyeing is the art of fixing a new and permanent colour on textile substances, usually cotton, linen, silk, and wool. Some preliminary operations are necessary in order to cleanse the stuff from any foreign matters which would prevent the dye having free access to it, as well as to remove any natural colouring which would interfere with the production of bright clear tints. Cotton and linen fabrics go through a prolonged series of operations in bleaching (which see). Silk is boiled in a solution of fine soap to remove the fatty matter; and wool is cleansed by scouring in weak soap or soda-lye or weak ammonia.

The process of dyeing varies much according to the stuff and the colouring matters used. In general animal fibres, like silk and wool, combine more easily with most colours than vegetable fibres such as linen and cotton. In the case of the former, for example, a simple immersion in aniline dyes is sufficient to produce a fixed colour. Such colours are said to be *substantive*, in relation to the stuffs with which they thus combine. Dyes which will not unite directly with the fibres so as to produce a good and permanent colour, are termed *adjective*. These dyes require the intervention of another agent to fix them on the different stuffs, and the name of *mordant* is applied to those substances which are employed to make the stuff to be dyed and the dyeing colour combine. Alum, acetate of alumina, chloride of tin, salts of iron, albumen, gluten, tannin, &c., are common mordants. The mordant is generally dissolved in water into

which the stuffs to be dyed are plunged. In some cases it is mixed with the colour and both are simultaneously applied to the stuff. An important characteristic of mordants is their power of affecting the natural tint of the dye and thus enabling a variety of shades to be produced at small expense. Thus nitrates tend to give a yellow tinge to the colours, alumina deepens and oxide of tin brightens the natural tints. A process of dyeing to which the name of *Aero-hydraulic Dyeing* has been given, consists in forcing the colour through the material by hydraulic pressure. The advantages of the process (patented by Mr. G. C. Gibbs) are that the colour is forced equally through any thickness of the stuff, which thus remains bright till completely worn out.

The dye-stuffs in use at the present day are derived alike from the animal, mineral, and vegetable kingdoms. Amongst animal dyes *cochineal*, the female insect of *Coccus cacti*, produces the most valuable of scarlet and crimson dyes. A kindred insect, *Coccus ilicis*, produces *kermes*, an important red dye. Galls, which are used both as a dye and a mordant, are produced by the puncture of insects on the leaves and branches of the oak and other trees. Amongst the vegetable dyes in common use, madder, the root of the *Rubia tinctoria* is perhaps the most important, furnishing various shades of red, purple, brown, and black, as well as the famous Turkey-red. *Munjeet* is the root of a closely allied Indian plant. *Logwood*, *Brazil-wood*, *sandal-wood*, *fustic*, *sappan-wood*, are the chief woods used for dyeing purposes. For blue dyes, indigo, obtained from *Indigofëra tinctoria* and *Indigofëra Anil*, is still the most generally used. Safflower (got from the *Carthämus tinctoria*) yields a fine pink dye; various species of lichens give us a series of purple dyes known as *archil*, *cudbear*, and *litmus*. Amongst mineral pigments *Prussian blue*, a ferrocyanide of iron; *ultramarine*, now prepared as a compound of alumina, silica, soda, and sulphur; *chrome yellow*, *cobalt blues*, and *arsenical greens*, are the colours most in use. Amongst the most notable additions to the list of colouring stuffs within recent years are the aniline dyes of coal-tar origin (see *Aniline*), which yield a great variety of brilliant colours, such as magenta, mauve, aniline, purple, roseine, violine, &c. From coal-tar also the two colouring principles of madder (*alizarine* and *purpurine*) have been artificially produced, and in Britain at least

alizarine has almost entirely superseded the use of the madder root. There are few organic substances which under proper treatment will not yield colouring matter, and of late new colouring matters have been obtained from wood-sawdust, lichens, mosses, paper and cotton waste, bran, starch, sugar, soot, &c. In addition to those above mentioned other dye-stuffs are alkanet, annatto, catechu, camwood, French berries, divi-divi, sumach, saffron, turmeric, woad, &c.

Dyer, JOHN, English poet of the secondary class, born in Carmarthenshire in 1700, and educated at Westminster School. He became a painter, but not succeeding in that capacity took orders and was appointed to a small living. In 1727 he published his poem of Grongar Hill, in 1740 *The Ruins of Rome*, and in 1757 *The Fleece*, a didactic poem in five books. He died in 1758.

Dyer's-broom, a European and now also N. American shrub (*Genista tinctoria*), formerly used with woad for dyeing green.

Dyer's-moss, a lichen, called also *Orchil* or *Archil*. See *Archil*.

Dyer's-weed, *Resëda Luteöla*, a plant of the same genus as mignonette, otherwise called *Yellow-weed*, *Weld*, or *Woad*, nat. order Resedaceæ. This plant grows in waste ground; it affords a beautiful yellow dye, and is cultivated for that purpose.—*Dyer's Greenweed* is *Genista tinctoria*. See *Dyer's Broom*.

Dye-stuffs. See *Dyeing*.

Dying Declaration, a deposition made by one who is in prospect of death. Such declarations are as a general rule admissible as evidence only in criminal and not in civil cases, and must be made, according to English and American, though not Scottish law, in the full consciousness of the danger of death.

Dyke. See *Dike*.

Dy'nam, a term proposed to express a unit of work equal to a weight of 1 lb. raised through 1 foot in a second; a foot-pound.

Dynam'eter, an instrument used for measuring the magnifying power of telescopes. It consists of a small compound microscope, with a transparent plate, exactly divided, which is fixed to the tube of a telescope, in order to measure exactly the diameter of the distinct image of the eye-glass. Also same as *Dynamometer*.

Dynamic Theory, a theory explanatory of the essential constitution of matter. In the dynamic theory every body is considered as a space filled with continuous matter;

porosity then becomes an accidental quality, but compressibility and dilatability essential properties. The state of a body depends entirely on certain attracting and repelling forces; and its volume must change with every change in the relative proportions of these forces. It is opposed to the *atomic theory*, which supposes every body to be composed of indivisible and impenetrable particles termed *atoms*. These are almost infinitely small, with void spaces between them, so that this theory makes porosity essential to matter.

Dynam'ics is the science which deals with the laws of force in their relation to matter at rest or in motion, and as such it is differentiated from *kinematics*, which considers motion mathematically, and apart from the forces producing it. It is to Newton that we owe the clear statement of the three primary laws of force. These are: (1) that every body remains in a state of rest, or of uniform motion along a straight line, unless it is compelled by force to change that state. (2) That change of motion is in proportion to the force employed, and occurs along the straight line in which the force acts. This change of motion includes both change of rate and of direction. (3) That, as the result of every action, there is also and always an equal reaction. These laws, which were formulated from experiment, involve the conception of force as a primary influence or action expressed in terms of space, time, and matter. Now, in dealing with the laws of force, a standard of measurement is required which shall be applicable to all forces at all times, and we therefore require to begin by establishing units of space, time, and mass. There are two systems of units in use, the one British, the other French. In the British system the foot is taken as the unit of length, and the second as the unit of time. In the French the centimetre is the unit of length, the second the unit of time; the unit velocity in the one case being that of one foot per second, in the other one centimetre per second. The British unit of mass is the pound (the mass of a certain lump of platinum deposited in the exchequer office, London); the French the gramme; and accordingly the French units of space, mass, and time are commonly known as the C.G.S. (centimetre, gramme, second) units. As the weight of a pound (or a gramme) is not the same at all parts of the earth's surface it cannot give us of itself an absolute or dynam-

ical unit of force, that is, an invariable unit; but taking it in conjunction with unit time and unit velocity, we do obtain such a unit. Two absolute units of force are in common use in dynamics, the *poundal* and the *dyne*; the latter being the absolute unit in the C.G.S. system. The former is *that force which, acting on the mass of one pound for one second, generates in that mass a velocity of one foot per second*. The latter is *that force which, acting on the mass of one gramme for one second, generates in that mass a velocity of one centimetre per second*. It is important in dynamics to distinguish between *mass* and *weight*. The *mass* of one pound is the quantity of matter equal to a certain standard quantity (a certain lump of metal) and is quite independent of force. The *weight* of one pound is the force with which the mass of one pound is attracted to the earth's surface by the force of gravity. Another important term is *momentum*: the momentum of a body in motion at any instant is the product of the mass of the body and the velocity at that instant. Dynamics is divided into two great branches: *statics*, which treats of solid bodies at rest under the action of forces; and *kinetics*, which treats of the action of forces in producing motion in solid bodies. Formerly the latter alone was called dynamics, and to this, in conjunction with statics, the general name *mechanics* was given. In the wide sense dynamics includes also hydrostatics.

Dyn'amite, an explosive substance patented by A. Nobel in 1867. As originally made it consists of a siliceous earth obtained at Oberlohe in Hanover and known as *kieselguhr*, impregnated with 75 per cent of nitro-glycerine (see *Nitro-glycerine*), the object of the mixture being to facilitate the carriage and use of the substance by diminishing its susceptibility to explode by shock while not destroying its explosive force. The siliceous matter is of diatomaceous origin; it is extremely friable and porous, and has a considerable absorbent power. Dynamite thus prepared has the appearance of raw sugar. Diatomite, a substance superior to *kieselguhr*, is now also employed, and various other substances have been used to mix with the nitro-glycerine, such as charcoal, sand, saw-dust, &c. The mixture remains without change for any length of time, unless exposed to water. It burns away quietly if a light is applied to it, but explodes if heated to a high temperature.

Usually it is exploded by a specially arranged fulminating cap. Its explosive force is several times that of gunpowder, which it has largely superseded for blasting.

Dynamo, the name now usually given to what was originally called the *dynamo-electric machine*. The object of such machines is to produce electric currents by means of mechanical power, and they differ from *magneto-electric* machines, which have a similar object, by the circumstance that in place of the permanent steel magnets which form a necessary part of a magneto-electric machine, electro-magnets are employed. In the original dynamo-electric machines the current by which the electro-magnets were made was identical with the current given off by the machine, or else was a portion diverted from it; but in an important class of machines the current which makes the electro-magnets has an independent source, and to these machines the name 'dynamo' is also applied. The advantage of dynamo over magneto machines lies in their greater compactness, arising from the fact that electro-magnets are much stronger than permanent steel magnets of the same bulk. The extensive use of dynamos as the principal commercial sources of electric currents may be said to date from the improvements introduced in their construction by Gramme of Paris. For an explanation of their action, see *Induction, Magneto-electric; Magneto-electricity*.

Dynamometer, any instrument for measuring the relative strength of men or animals, or the force of machinery. Commonly it consists of a spiral spring suitably applied. When the pull upon a draught implement, as a plough for instance, is the point to be determined, the dynamometer is made a link in the draught-chain, and the amount of extension or collapse which it suffers indicates the intensity of the strain.

Dyne (dīn), in physics, a unit of force. See *Dynamics*.

Dyrrhachium. See *Durazzo*.

Dy'sart, a royal and parliamentary burgh of Scotland, in Fife, on the Firth of Forth. It is an old place, and is a member of the Kirkcaldy district of parliamentary burghs. Pop. of royal burgh, 2623; of parl. burgh, 1891, 19,742.

Dysentery (Greek, *dys*, difficult, *entera*, the bowels), a dangerous disorder of the intestines, known by fever; frequent griping stools; tenesmus; stools, chiefly mucous, sometimes mixed with blood, the natural

fæces being retained, or voided in small, compact, hard masses; loss of appetite and nausea. It may be occasioned by a sudden check in the perspiration, or the use of unwholesome and putrid food, or by noxious exhalations and vapours, and it is often the result of a specific contagion. When the symptoms run high, produce great loss of strength, and are accompanied with a putrid tendency and a fetid and involuntary discharge, the disease often terminates fatally in a few days. In some cases the febrile state wholly disappears after a time, while the proper dysenteric symptoms may be of long continuance. Hence the distinction into acute and chronic dysentery. Saline purgatives, and for severe cases laudanum (20 or 30 drops) or Dover's powder, are useful. The endemic dysentery of Egypt is a distinct disease caused by the presence of a worm in the intestines.

Dysmenorrhœa, a disease of women, consisting in painful or difficult menstruation, which may be caused in various ways.

Dysodile, a yellowish or greenish foliated mineral found in limestone, with remains of fish and of plants, which, when ignited, burns and emits a very bad smell.

Dyspepsia (Greek, *dys*, difficult, and *pepsis*, digestion), difficulty of digestion. The action of the stomach on the food is that usually designated as digestion, and it is the derangement of this process that is usually expressed by the term dyspepsia. This derangement may be caused by disorders of a very various and even opposite character. The sub-acute and chronic forms of gastric irritation and inflammation are the most common forms of dyspepsia, and are often caused by too highly-seasoned or too abundant food and stimulant drinks, or by the improper use of emetics, tonics, or stimulants. Another class of dyspeptic diseases is connected with irritation of the mucous membrane of the duodenum, causing perversion of secretions and disorder of functions. A third class of dyspeptic diseases depends on the nerves connected with the digestive viscera. Hence arises an order of dyspeptic symptoms independent of any immediate affection of the stomach. Dyspepsia is therefore not a disease of a uniform character, but is rather attached as a symptom to a variety of diseases. The most common causes of dyspepsia are excesses of various kinds, especially in the quantity of food eaten. Persons of a sedentary life require less nutriment than those of active

habits. Exercise and the quantity of food to be digested must be proportioned to each other. The quality of food as well as its quantity has to be considered. Good cookery, which renders the food tender and pulpy, is one preservative against dyspepsia. Tough and badly-dressed meats, crude vegetables, hot bread and cakes, and the daily use of hot tea or coffee for breakfast, are amongst the numerous causes of this ailment.

Dyspho'nia, a difficulty in speaking. The disorder known as 'clergyman's sore-throat' is a common example. Rest of the vocal organs, tonics, muscular exercise, change of scene, are generally needed to aid recovery.

Dyspnoea (dis-pnē'a), difficulty in breathing. It is sometimes hysterical, sometimes a symptom of disease of the heart or lungs. The treatment varies with the cause.

Dytiscus, more correctly **DYTICUS**. See *Water-beetle*.

Dze'ren, **DZE'RON**, the Chinese antelope, a

remarkably swift species of antelope (*Procapra gutturōsa*) inhabiting the dry arid deserts of Central Asia, Thibet, China, and Southern Siberia. It is nearly $4\frac{1}{2}$ feet in length, and $2\frac{1}{2}$ high at the shoulder.

Dzig'getai, or **KIANG** (*Equus Hemiōnus*), an animal found in Central Asia, allied both to the horse and ass. Its head is large like that of the ass, but in form resembles that of the horse. The ears also resemble those of the horse. It runs with a rapidity exceeding that of the best Arabian horses.

Dzoungaria, a Chinese territory in Central Asia, stretching from about 43° to 48° N. lat. and from about 82° to 86° E. lon. It has an area of 147,950 sq. miles, and pop. 600,000. It is administratively connected with Kuldja, and since the surrender of Kuldja by the Russians in 1880 is again under Chinese rule. Dzoungaria, once the centre of an independent empire, was first conquered by the Chinese in 1757.

E.

E, the second vowel and the fifth letter of the English alphabet. It occurs more frequently in English words than any other letter of the alphabet. Its long or natural sound in English coincides with the sound of *i* in the Italian and French languages, as in *here, mere, me*. It has also another principal sound, a short one, heard in *met, men*. It has besides a sound like *a* in *bare*, as in *there, where, &c.*, and the obscure sound which is heard in *her*. As a final letter in English it is generally silent, but it serves to indicate that the preceding vowel is to have its long sound, as in *mane, cane, plume*. When two *e*'s come together the sound is generally the same as that of the single *e* long, as in *deem, esteem, need* (comp. however *pre-exist, &c.*).

E, in music, is the third note or degree of the diatonic scale, answering to the *mi* of the Italians and French.

Eadie (ē'di), **JOHN**, D.D., a Scottish preacher and theologian, born 1810, died 1876. He was educated at Glasgow University, and entered the ministry of the Secession Church, becoming in 1843 professor of biblical literature in the Divinity Hall of the church, a post which he continued to hold after the Secession body was merged in the United Presbyterian Church (in 1847). Among his works are Biblical

Cyclopædia; Analytical Concordance to the Scriptures; Ecclesiastical Cyclopædia; Commentary on the Greek Text of Ephesians, and similar works on Colossians, Philippians, and Galatians; and The English Bible. He was one of the scholars engaged on the Revised Version of the New Testament.

Ead'mer, an English monk, the friend and biographer of St. Anselm. In 1120 he was chosen Bishop of St. Andrews; but as the Scottish king refused to recognize the right of the Archbishop of Canterbury to consecrate him, he returned to England and died a simple monk about 1124. Besides the life of St. Anselm, Eadmer wrote lives of St. Wilfrid, St. Dunstan, St. Odo, and other English saints, as well as a valuable history (*Historia Novorum*) of events in England and the English Church from 1066 to 1122.

Eagle, the general name of raptorial birds that form a group or sub-family (*Aquilinæ*) of the great family *Falconidæ*, which includes the eagles, falcons, and hawks. The eagle is popularly regarded as the noblest and most courageous of the rapacious birds. It soars to a greater height than any other European bird, from which circumstance the ancients considered it as the bird or messenger of Jove. The genus *Aquila* which includes the most typical eagles, is distinguished by its long and powerful bill,

the curve commencing at the cere, by its wings reaching to the tip of the tail, and by its tarsi being feathered to the toes. The imperial eagle (*A. imperialis*) of Central Europe is probably the species to which the popular belief in the courage, strength, and nobleness of eagles is to be traced. *A. chrysaetus*, the golden eagle, is the chief British species. It measures over 6 feet from tip to tip of the expanded wings, and 3 feet



Imperial Eagle—*Aquila imperialis*.

from the beak to the end of the tail. The adults have the body brownish, becoming darker with age; the feathers of the head and neck pointed, and of a golden-red hue. This species is found all over the northern hemisphere. It was once common in the Highlands of Scotland, but is now becoming rare. The Kirghis and other tribes of Central Asia use the golden eagle to kill antelopes, foxes, and even wolves. Another British eagle is the erne or sea-eagle (*Haliaëtus albicilla*) found near the sea-coast or lakes, and feeding largely on fish. The general colour is grayish-brown, the head pale-coloured, the tail white. The bald eagle (*Haliaëtus leucocephalus*), found in North America and North-east Asia, is the symbol of the U. States, though Franklin deplores the selection on account of his mean and dishonest habit of robbing the industrious osprey of the fish caught by him. Like all members of the genus his diet is less restricted than that of the true eagles; and he even takes carrion. Another eagle (*Circaëtus gallicus*), the serpent eagle, or short-toed eagle, ranges through Southern

Europe, Asia, and especially North Africa. In structure and habits this bird approaches the buzzards. See also *Harpy Eagle*.

Eagle, as a symbol. The eagle first appears as a war standard amongst the Persians, through whom it reached the Egyptians. As the standard of the Roman armies it was first used by Marius, and latterly took the place of all the other emblems at the head of the legions. It was first made of wood, then of silver, and finally, under Cæsar and his successors, of gold. In the mediæval ages the eagle became the heraldic emblem of the old German Empire, and was made double-headed in the 14th century. When the old German Empire ceased the double-headed



Roman Eagles.

eagle was retained by Austria. A double-headed eagle is also the national military symbol of Russia, as a single-headed eagle is that of Prussia and the United States of America; the latter stands with outspread wings guarding a shield, with the motto *E pluribus unum*. The eagle is also the badge of several orders, the chief of which are the order of the *Black Eagle*, founded in 1701, and the highest order in Prussia; the order of the *Red Eagle*, also a Prussian order, and founded in 1705; the Russian order of the *White Eagle*, originally Polish, and instituted in 1325.

Eagle, a gold coin in the United States of the value of ten dollars, or £2 sterling. It was first coined in 1795. There are also half-eagles, quarter-eagles, and double-eagles, of proportionate values.

Eagle, a lectern or reading-desk in churches in the form of an eagle with expanded wings.

Eagle-hawk, a name of birds (genus *Morphnus*) belonging to the eagle group, but smaller than the true eagles, with comparatively short wings and long legs, natives of South America.

Eagle-owl, one of a sub-family of owls (*Buboninæ*), the most remarkable species of which is the *Bubo maximus* (the great horned owl), little inferior in size to the golden eagle. It is found in the mountainous parts of Central Europe. An allied species, the Virginian horned owl (*B. virginianus*), is found in almost every quarter of the United States.

Eagle-wood. See *Aloes-wood*.

Eagre (*ē'gèr*), a Norse word signifying the same as *bore* in a river. See *Bore*.

Ear, the organ of hearing. It is situated at the side of the head, and in the higher vertebrates is divided into the outer, middle, and inner ear. The external ear,

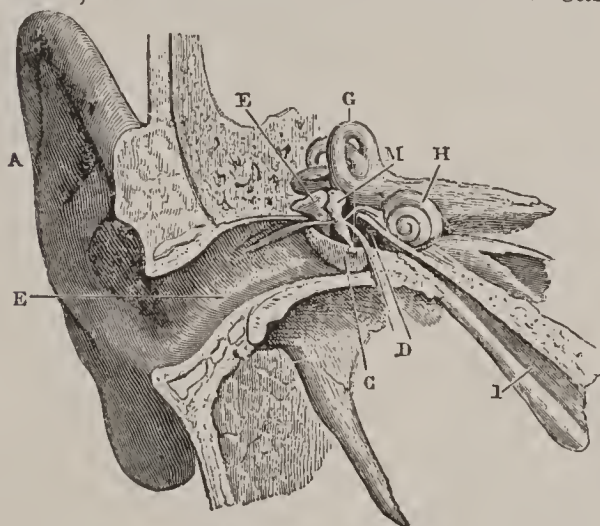

The Ear of the Right Side.

which is a cartilaginous funnel for collecting the sound waves and directing them inwards, is composed of the *pavilion*, or projecting part, and of the *auditory canal*, which extends from the *concha*, or central hollow of the pavilion, to the membrane of the *tympanum* or *drum*. This membrane is a partition stretched obliquely across the bottom of the auditory canal, which it separates from the middle ear or drum; it is semi-transparent and very delicate. It vibrates with the waves of sound which strike against it, and transmits the vibrations to certain little bones of the cavity of the tympanum. These bones, which have been named respectively the hammer (*malleus*), the anvil (*incus*), and the stirrup (*stapes*), transmit the vibrations to the internal ear, forming a chain communicating at one end with the membrane just mentioned, and at the other with the inner ear. The internal ear consists of a bony cavity called the *vestibule*, three *semicircular canals*, and a bony structure in the form of a spiral shell, called the *cochlea*. The vestibule communicates with

the tympanum, the cochlea, and the semicircular canals, and is entered by branches of the nerve of hearing. The various parts of the internal ear, which together form the *osseous labyrinth*, are lodged in the hardest part of the temporal bone; they are lined throughout with a very thin membrane, and are full of a very thin and limpid fluid. They contain a structure of corresponding form called the *membranous labyrinth*, consisting of sacs and canals, also containing a fluid. Within the membranous canal of the cochlea is lodged the complicated apparatus which is believed to be the chief agent in the perception of sound. The middle ear communicates with the throat and pharynx by the Eustachian tube, through which air from the mouth may be pressed against the membrane of the drum. In the external auditory canal of the ear is produced the cerumen or ear-wax, which if allowed to accumulate may cause deafness. The cut shows A the pavilion, B the external canal, C the drum membrane partly removed, D cavity of middle ear, E anvil and M hammer, the small bones communicating with the drum and vestibule, H cochlea, G semicircular canals, I Eustachian tube.

Ear-cockle, a disease in wheat caused by the presence in the grain of worms belonging to the genus *Vibrio*. Called in some parts of England *purples*.

Earl, a degree of the British nobility between marquis and viscount, the title of highest antiquity in England. The title was made hereditary by William the Conqueror, and for a time was used interchangeably with that of *count*, the corresponding title on the Continent. The wife of an earl is still called a *countess*. An earl's coronet is composed of eight pearls raised upon points, with small leaves between, above the rim. See *Coronet*.

Earle, JOHN, English bishop and writer, born about 1601, died 1665. He was educated at Oxford, and after writing some short poems gave to the world anonymously in 1628 *Microcosmographie, or a Piece of the World discovered in Essays and Characters*—a work full of wit, humour, and admirable character-painting. He was tutor to Charles II., accompanied him during his exile, and was held by him in the highest esteem. In 1662 he was consecrated Bishop of Worcester, and next year was translated to Salisbury.

Earlestown, a town of Lancashire, England, 14 miles east of Liverpool. There are

EARL-MARSHAL — EARLY ENGLISH ARCHITECTURE.

here the wagon works of the London and N.W. Railway. Pop. 5497.

Earl-marshal, a great officer of England,

the Pointed or Gothic styles of architecture that prevailed in England. It succeeded the Norman in the reign of Richard I.



Early English Style.—North-west Transept of Beverley Minster.

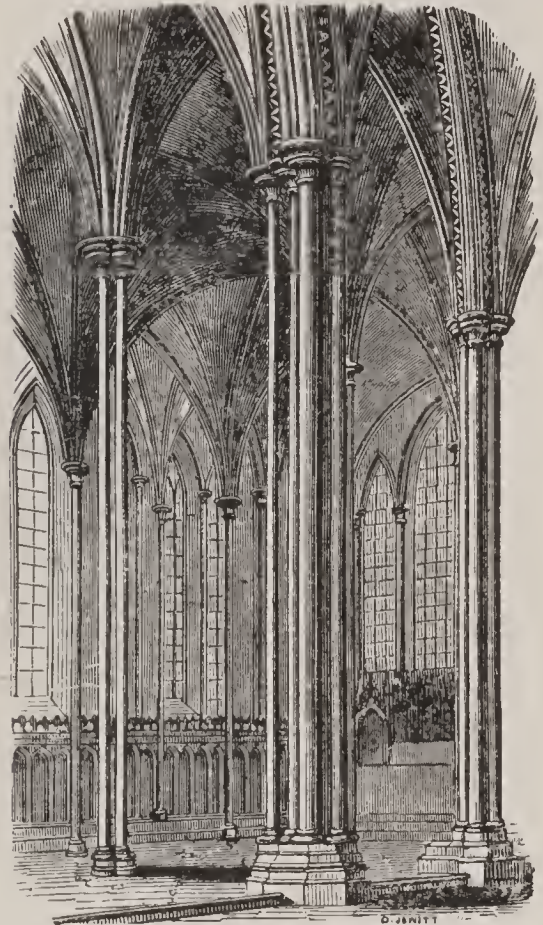

Early English Style.—Detached Shafts in Lady Chapel, Salisbury Cathedral.

who had, anciently, several courts under his jurisdiction, as the court of chivalry and the court of honour. He is the head of the College of Arms (Heralds' College), grants armorial bearings, and determines all claims in connection with them. The office is hereditary in the family of the Howards. There was also an earl-marshal of Scotland, the office being hereditary in the Keith family.

Earlom, RICHARD, English mezzotinto engraver, born 1743, died 1822. His engravings from Reynolds, Hogarth, Van Huisum, &c., are very fine.

Early, JUBAL A., General, was born in Franklin co., Va., Nov. 3, 1816. He served in the Florida and Mexican wars. In the war against the Union his want of success compelled Gen. Lee to remove him from command. Since the war a manager of the Louisiana lottery.

Early English Architecture, the first of

(1189), and continued to the end of the reign of Henry II. in 1272, a period of 123 years, when it gradually merged into the Decorated style. One of the leading peculiarities in

this style is the form of the windows, which are narrow in proportion to their height, and terminate in a pointed arch, resembling the blade of a lancet. Throughout the early period of the style they are very plain, particularly in small churches; but in cathedrals and other large buildings the windows, frequently combined two or more together, are carried to a great height, are richly and deeply moulded,



Early English Capital, Salisbury.

and the jambs ornamented with slender shafts. On the eastern and western fronts of small churches the windows are often combined in this manner, with a circular window above and a richly moulded door below; but in large buildings there is often more than one range of windows, and the combinations are very various. Though

separated on the outside, these lancets are in the interior combined into one design, thus giving the first idea of a compound window. The doorways are in general pointed, and in rich buildings sometimes double; they are usually moulded, and enriched with the tooth-ornament. The buttresses are often very bold and prominent, and are frequently carried up to the top of the building with but little diminution, and terminate in acutely-pointed pediments, which, when raised above the parapet, produce in some degree the effect of pinnacles. In this style, likewise, flying-buttresses were first introduced (see *Buttresses*), and the buttresses themselves much increased in projection owing to the comparative lightness of the walls, which required some counter-support to resist the outward pressure of the vaulting. The roof in the Early English style appears always to have been high pitched, and the towers surmounted by lofty pointed spires, as at Salisbury Cathedral (illustrated at *Gothic*). In the interior the arches are usually lancet-shaped, and the pillars often reduced to very slender proportions. As if to give still greater lightness of appearance, they are frequently made up of a centre pillar, surrounded by slight detached shafts, only connected with the pillar by their capitals and bases, and bands of metal placed at intervals. These shafts are generally of Purbeck marble, the pillar itself being of stone, and from their extreme slenderness they sometimes appear as if quite inadequate to support the weight above them. Some of the best examples are to be seen in Salisbury Cathedral. The architects of this style carried their ideas of lightness to the utmost limits of prudence, and their successors have been afraid to imitate their example. The abacus of the capitals is generally made up of two bold round mouldings, with a deep hollow between. The foliage is peculiar, generally very gracefully drawn, and thrown into elegant curves; it is usually termed *stiff-leaved*, from the circumstance of its rising with a stiff stem from the neck-mould of the capital. The trefoil is commonly imitated, and is very characteristic of the style. The mouldings of this style have great boldness, and produce a striking effect of light and shade. They consist chiefly of rounds separated by deep hollows, in which a peculiar ornament, called the *dog's-tooth*, is used, whenever ornament can be introduced. This ornament is as characteristic of the Early English as

the zigzag is of the Norman. See *Dog's-tooth*.

Earnest, in law, any sum paid in advance, to bind parties to the performance of a verbal agreement, or something given by a buyer to a seller as a pledge of adherence to a bargain. The party is then obliged to abide by his bargain, and is not discharged upon forfeiting his earnest. In the U. S. the general view is, that the sum paid as earnest, however small, is part of the price.

Ear-ring, an ornament for the ear, consisting of a ring or hook passing through the lobe, with a pendant of diamonds, pearls, or other jewels frequently attached. Ear-rings were commonly worn amongst the Oriental nations, and by both sexes, from the earliest times. Amongst the Greeks and Romans they were not so commonly worn by men as by women. In England the Romanized Britons and the Anglo-Saxons wore them, but the fashion declined in the 10th century, and was again introduced in the 16th century, in Queen Elizabeth's time.

Ear-shell, a name given to certain univalve molluscs of the genus *Haliotis* (which see).

Earth, the planet which we inhabit, a nearly spherical body which every twenty-four hours rotates from west to east round an imaginary line called its axis—this axis having as its extremities the north and south poles respectively—while in the course of a year it completes a revolution round the sun. To an observer whose view is not obstructed any part of the earth presents itself as a circular and horizontal expanse, on the circumference of which the heavens appear to rest. Accordingly, in remote antiquity, the earth was regarded as a flat, circular body, floating on the water. But even in antiquity the spherical form of the earth began to be suspected. It is only on this supposition that we can explain how the horizon of vision grows wider and wider the higher the position we choose, how the tops of towers and mountains at a distance become visible before the bases, how the hull of a ship first disappears as she sails away, and how, as we go from the poles towards the equator, new stars become visible. Besides these proofs there are many others, such as the circular shadow of the earth seen on the moon during an eclipse, the gradual appearance and disappearance of the sun, and, lastly, the fact that since 1519 it has been regularly circumnavigated.

EARTH.

The earth is not, however, an exact sphere, but is very slightly flattened at the poles, so as to have the form known as an *oblate spheroid*. In this way the *polar diameter*, or diameter from pole to pole, is shorter than the diameter at right angles to this—the *equatorial diameter*. The most accurate measurements make the polar diameter about 27 miles less than the equatorial, the equatorial diameter being found to be 7925·6 miles, and the polar 7899·14. The earth is regarded as divided into two halves—the northern and the southern hemisphere—by the *equator*, an imaginary line going right round it midway between the poles. In order to indicate with precision the position of places on the earth additional circles are imagined to intersect one another on the surface in such a manner that those of the one set all pass through both poles, while those of the other are drawn parallel to the equator. The former are called *meridians*, the latter *parallels of latitude*, and by them we can tell the latitude and longitude, and thus the exact position of any place.

Many experiments by various methods have been made in order to determine the average density of the earth, that is, the quantity of matter it contains. Amongst these methods may be mentioned: (1) that of determining the attraction of a mountain on the direction of a plumb-line and calculating from thence the density of the earth; (2) that founded on the difference of oscillation in a pendulum when placed at the summit of a mountain and when at the sea-level; (3) the converse of the preceding method, by the determination of the difference of gravity at the top and the bottom of a deep mine, by pendulum experiments; (4) Cavendish's experiment with the torsion balance, which attempts to compare the attractive force of two large lead balls over other two small lead balls with that exercised by the earth. From these and other experiments it has been calculated, taking the mean of all results, that the density of the earth is to that of water as 5·639 to 1.

The earth, in common with the other planets, moves round the sun, completing its revolution in about 365 days and six hours, and thus forming our common year. The orbit of the earth is an ellipse, with the sun in one of its foci. Hence the earth is not equally distant from the sun in all parts of the year; being about 3,000,000 miles nearer at one time than another, its least distance (*perihelion distance*) according to recent

calculations being 89,897,000 miles, its greatest (*aphelion distance*) 92,963,000, and the mean distance, or half the length of the long axis of the orbit, 91,430,000 miles. From this it may be calculated that the velocity of the earth in its orbit is about 17 miles a second. In winter (speaking of the northern hemisphere) the earth is nearest the sun and in summer farthest from it; for the difference in the summer and winter temperature is not occasioned by the greater or less distance of the earth from the sun, but by the more or less oblique direction of the sun's rays. The passage of the earth round its orbit causes the sun to appear as if it described a similar orbit in the heavens; and hence it is that at one time of the year one group of stars is seen in the neighbourhood of the sun at sunrise and sunset and at another time another group. This apparent path of the sun is the *ecliptic*, and corresponds with what would be the path of the earth as seen from the sun; and the groups of stars through which the sun successively passes form the *zodiac*.

The earth's daily motion about its own axis takes place, according to mean time, in twenty-three hours, fifty-six minutes, and four seconds. This diurnal revolution is the occasion of the alternation of day and night. As the axis on which the earth performs its diurnal rotation forms with the plane of its path about the sun an angle of $23\frac{1}{2}^{\circ}$ (which angle also represents that between the plane of the ecliptic and the plane of the earth's equator), the sun ascends in the heavens, from March 21 to June 21 (the summer *solstice*), about $23\frac{1}{2}^{\circ}$ above the equator towards the north pole, and descends again towards the equator from June 21 to September 23; it then sinks till December 21 (the winter *solstice*), about $23\frac{1}{2}^{\circ}$ below the equator, towards the south pole, and returns again to the equator by March 21. This arrangement is the cause of the seasons, and the inequality of day and night attending them. For all countries lying beyond the equator, day and night are equal only twice in the year (at the *equinoxes*). At the summer solstice the north pole of the earth is turned towards the sun, and the south pole away from it, and for $23\frac{1}{2}^{\circ}$ round the former there is a period of longer or shorter duration during which the sun is continually above the horizon for more than 24 hours, while round the latter there is an equal extent of surface within which the sun for similar periods is below the horizon. (See *Day*.) The reverse

state of matters occurs at the winter solstice. The circles bounding these regions are called respectively the *arctic* and the *antarctic* circle, and the regions themselves the *polar* or *frigid zones*. Throughout a region extending to $23\frac{1}{2}^{\circ}$ on each side of the equator the sun is directly overhead at every point in succession twice in the year. The circles which bound this region are called the *tropics*, that in the northern hemisphere being the tropic of *Cancer*, that in the southern the tropic of *Capricorn*, while the region between is the *torrid zone*. The regions between the tropics and the polar circles are respectively the *north* and *south temperate zones*.

From the evidence furnished by volcanoes, hot springs, sinking of mines, &c., it is known that the earth has a high internal temperature of its own. Taking the average of the various observed rates of increase this temperature seems to increase 1° Fahr. for every 60 ft. of descent. Assuming this to continue, the rocks at a depth of 2 miles would be as hot as boiling water, and at a depth of 50 miles the heat would be such as at the surface would melt every known solid. This being so, various theories as to the internal condition of the earth have been proposed: (1) That a thin envelope or crust surrounds a molten interior. It can be shown, however, that as tides must be produced in such a molten mass the cool outer crust would be unable to withstand the enormous force of these unless it were about 2000 miles thick. (2) That the interior is solid, with spaces here and there filled with liquid or gaseous material. This theory assumes that there are within the earth enormous cavities filled with molten rock, which escapes when local pressure is removed in the form of volcanic outbursts. (3) That the earth consists of a thin crust, a large solid nucleus, and a liquid film between the nucleus and the crust; the temperature at the centre being not much greater than comparatively near the surface. (4) That the earth is solid to the centre, but any part may become liquid if local pressure is removed. We know that if the pressure on a solid be increased the melting point is correspondingly raised; now the pressure at the centre of the earth, or even at the depth of 50 or 100 miles, must be something enormous, and probably is so great as to keep the rocks there permanently in a solid condition, notwithstanding the heat. This last theory is considered the most probable. On the sup-

position of its correctness volcanoes might be explained by supposing that at certain points here and there pressure is removed by the elevations of portions of the earth's surface which are constantly taking place, and that this allows the rocks to liquefy. Water may then soak down to these liquid rocks, and being converted into steam produce the various volcanic phenomena.

The earth (like the other planets) is believed to have condensed and solidified from a gaseous or nebular condition, and to have once had a far higher temperature than now. If such were the case the outer surface, losing heat by radiation, would be the first part to cool quickly; while the interior, losing its heat by conduction, would not cool so rapidly, and therefore would naturally have a higher temperature than the portion at the surface. This is what all observations indicate the condition of the earth to be, and the shape of the earth also indicates that it must once have been in a fluid state. Even the time at which it was in the fluid state has been roughly calculated by Sir W. Thomson, whose estimate makes it about 200 millions of years ago. See *Nebular Hypothesis*.

Another feature that the earth as a whole presents is its magnetism. When a magnetic needle is balanced on a point it remains at rest in one position only, pointing then nearly due north and south. This can be explained only on the supposition that the earth acts as a great magnet. It has in fact two poles—a north and a south magnetic pole—which are not very far from, but by no means coincident with, the geographical poles. There is also a neutral line or magnetic equator, which does not greatly diverge from the geographical equator. The earth acts upon all magnets as they act upon each other, and it is for this reason that they point north and south.

The surface of the earth contains over 196,000,000 square miles, of which scarcely a third-part is dry land, the remaining two-thirds being water. The land is arranged into masses of irregular shape and size, the greatest connected mass being in the eastern hemisphere. The chief masses receive the name of continents, detached masses of smaller size forming islands. The surface of the land is variously diversified, exhibiting mountains, valleys, plains, plateaus, deserts, &c. The water area of the earth is divided into oceans, seas, bays, gulfs, &c., while rivers and lakes may be regarded as

features of the land surface. The great phenomena of the oceans are currents and tides. The population of the whole earth is estimated at from 1350 to 1450 millions. The earth is attended by the moon as a subordinate or subsidiary planet. See also such articles as *Climate, Currents, Ocean, Earthquake, Seasons, &c.*

Earth-closet, a place in which the fæces from the human body are received in a quantity of earth. The advantages of the earth-closet system are due to the fact that dry earth is one of the best disinfectants and deodorizers, and that the compound formed by the combination of the fæcal matter and the earth is valuable and easily applied as manure. In large cities the earth-closet system would hardly be practicable on account of the expense of preparing and storing large quantities of earth, but in agricultural districts the system might be employed with great advantage.

Earth-currents, violent electrical disturbances of the nature of transient currents, which rush in one direction or the other, and by which telegraph lines, and particularly long submarine lines, are constantly troubled. Their origin and nature are not thoroughly understood, but they are found to be very intimately connected with the perturbations of terrestrial magnetism called *magnetic storms*, and these, it is well known, are closely connected both with the appearance of the *aurora borealis* and with the occurrence of the sun's spots.

Earthenware, a name applied to the commoner sorts of pottery-ware. (See *Pottery*.) The older kinds of earthenware, such as Majolica, Delft-ware, Faïence, and Palissy-ware, are not only glazed, but are besides elaborately coloured and enamelled and ornamented with raised figures of various kinds.

Earth-houses, a name generally given throughout Scotland to underground buildings, also known as 'Picts' houses' or 'Picts' dwellings.' The earth-house in its simplest form consists of a single irregular-shaped chamber, formed of unhewn stones, the side walls gradually converging towards the top until they can be roofed by stones of 4 or 5 feet in width, all covered in by a mound of earth rising slightly above the level of the surrounding district. In the more advanced form of these structures two or three chambers are found. Earth-houses are frequent in the north-east of Scotland, occasionally thirty or forty being found in

the same locality. Querns, bones, deers' horns, earthen vessels, cups and implements of bone, stone celts, bronze swords, and the like, are occasionally found in connection with them. Very similar structures, known as beehive-houses, occur also in Ireland.

Earth-nut, the *Bunium flexuosum*, an umbelliferous plant common in woods and fields in Britain. The leaves are ternately divided, and the small white flowers are in terminal umbels. The tuber or nut is about 4 or 6 inches below the surface, at the termination of a long slender root. It is brown, the size of a chestnut, of a sweetish farinaceous nature, resembling in taste the common chestnut. Swine are very fond of the nuts, and fatten rapidly where they are abundant. The name is frequently applied to *Bunium Bulbocastanum*, which has a similar tuber. The earth-nut of Egypt is the tuber of *Cypërus rotundus* and other species of the same genus, that of China the subterranean pods of *Arăchis hypogæa*, a leguminous plant.

Earthquake, a shaking of certain parts of the earth's surface, produced by causes not perceivable by our senses. This motion occurs in very different ways, having sometimes a perpendicular, sometimes a horizontal undulating, and sometimes a whirling motion. It also varies much in degrees of violence, from a shock which is hardly perceptible to one which bursts open chasms and changes the appearance of the ground itself. During these shocks sometimes smoke and flames, but more frequently stones and torrents of water are discharged. There is little doubt that earthquakes and volcanic eruptions are kindred phenomena, the latter differing from the former principally in proceeding from a permanent crater. All observations go to prove that both are due to disruptions produced by internal heat at a great depth beneath the surface of the earth. Of the particular way in which this force works, however, there are various theories. It has been thought by some that the centre of earthquakes and volcanic disturbances is always near the sea or other large supplies of water, and that the disturbances are directly caused by the filtration of the water down to igneous matter, and the consequent generation of vast quantities of steam which frees itself by explosion. (See *Earth*.) Others have sought to explain earthquakes as part of the phenomena of a planet cooling at the surface. The most remarkable earthquakes of mod-

ern times are those which destroyed Lima, in 1746, and Lisbon in 1755; still more recent are the earthquakes that visited Calabria in 1857, Peru and Ecuador in 1868, the island of Ischia in 1884, Charleston and that district of the United States in 1886, Mentone and the Riviera of Italy in 1887, Greece in April, 1894, during which about 200 lives were lost and many buildings destroyed. In July, 1894, earthquake shocks killed several persons in Constantinople and much serious damage was done along the Dardanelles.

Earths, a term applied to certain tasteless, inodorous, dry, uninflamable, non-volatile, insoluble substances, difficultly fusible, and of a moderate specific gravity, which constitute by far the greatest part of the gravel and soil that go to make up the mountains, valleys, and plains of our globe. They include *lime*, *baryta*, *strontia*, *magnesia*, *alumina*, &c. The earths were regarded as simple bodies until Sir H. Davy proved them to be compounds of oxygen with metals.

Earth-shine, in astron. a name given to the faint light visible on the part of the moon not illuminated by the sun, due to the illumination of that portion by the light which the earth reflects on her. It is most conspicuous when the illuminated part of the disc is at its smallest, as soon after new moon. This phenomenon is popularly described as 'the old moon in the new moon's arms.'

Earth-tongue, the popular name given to club-shaped fungi of the genus *Geoglossum*, found in lawns and grassy pastures.

Earth-tremors, slight vibrations of portions of the earth's surface that may be noted by means of special instruments their cause not being known.

Earthworks (in fortification) are military works formed chiefly of earth and designed either as permanent or temporary defences. They are cheaper, more easily repaired, and expose their defenders to less risk from broken stone than stone-works.

Earthworm (*Lumbricus terrestris*), a genus of common worms, order Oligochæta, belonging to the abranchiata (having no branchiæ, or external respiratory organs) section of the class Annelida. They have a long, cylindrical body, divided by transverse furrows into numerous rings. The mouth is destitute of teeth, and they have no eyes, tentacles, or cirrhi. They are hermaphrodite. The common earthworm attains

nearly a foot in length. It subsists on roots, woody fibres, animal matter, &c. It moves by the contractions of successive parts of the body aided by a double row of bristles. They are of great service to the agriculturist by loosening the soil and increasing its depth. This is chiefly the result of their mode of nourishment, since they deposit the soil they have swallowed, after digestion, in heaps called *worm castings* which bring up rich fine soil to the surface, gradually covering the upper layer sometimes to the extent of several inches.

Ear-trumpet, an artificial instrument for aiding the collection of the vibrations or waves of sound, and carrying them in an intensified form to the internal parts of the ear. They are generally made of tin, vulcanite, gutta-percha, &c., and are of various forms. A small kind known as ear-cornets or acoustic auricles, attached to the ear by a spring, are sometimes used in slight cases of deafness.

Earwig (*Forficula*), a common orthopterous insect whose name is derived from its supposed habit of insinuating itself into the ears of persons. This is practically impossible, yet the notion is widely spread, as appears from the names given to the earwig in different languages, as in French *perceoreille* (pierc-ear), in German *ohrenhöbler* ('ear-borer'). Much damage is sustained by gardeners from the depredations of these insects among fruit and tender vegetables, which constitute their proper food. The earwig is about three-quarters of an inch in length, having the wings folded under very short and truncate elytra or wing-cases, and the extremity of the abdomen armed with a horny forceps.



Earwig (*Forficula auricularis*).

Easel (ē'zel), the frame on which an artist supports his canvas. It is usually made to fold up after use.

Easement, in law, a right or privilege which one proprietor may have to use the land of another in connection with the needs of his own land, as the use of a way, a water-course, &c. The right to an easement may be acquired either by grant or by uninterrupted enjoyment for a period of years.

East, one of the four cardinal points, being the point in the heavens where the

sun is seen to rise at the equinox, or the corresponding point on the earth; that point of the horizon lying on the right hand when one's face is turned towards the north pole. By *the East*, in an indefinite sense, is often meant Asia Minor, Syria, Arabia, Persia, India, China, &c.

Eastbourne, a watering-place of England, county of Sussex, situated on the English Channel, near Beachy Head. The town is handsomely built, having fine parades and well-planted walks and drives. Pop. 34,977.

East Cape, the most easterly point of Asia, projecting into Behring's Strait nearly opposite Cape Prince of Wales in Alaska.

Easter, the festival commemorating the resurrection of Christ, observed in the R. Catholic, the Greek, Anglican, Lutheran, and other branches of the Christian church. By the first Christians it was considered to continue the feast of the *passover*, at which the paschal lamb, a type of Christ, was sacrificed. Hence its name in Greek (*pascha*), French (*pâques*), and other Romance languages is taken from the Hebrew *pesach*, passover. The English name comes from the Ang.-Saxon *Eostre*, a goddess of light or spring, whose festival was celebrated in April. There was long a dispute in the Christian church as to the proper time for holding Easter, the Christians of the East celebrating it on the same day as that on which the Jewish passover fell, that is, the 14th of Nisan (hence they were called *quarto decimani*), while the majority of the church celebrated it on the Sunday next after this day. The controversy was decided by the Council of Nice (Nicæa) in 325, which settled that it was to be reckoned as at present, namely, that Easter is the first Sunday after the full moon which happens upon or next after the 21st of March, and if the full moon happens on a Sunday, Easter-day is the Sunday after, but, properly speaking, for the 'full moon' in the above the 'fourteenth day of the moon' should be substituted.

Easter Dues, or OFFERINGS, in the Church of England, certain dues paid to the parochial clergy by the parishioners at Easter as a compensation for the tithe for personal labour.

Easter Island, an island in the South Pacific Ocean, lon. 109° 17' w.; lat. 27° 6' s. It is of a triangular form, one side about 12 miles long, the other two about 9 each; highest point, 1200 feet. The soil is fertile, but little cultivated. There are some re-

markable sculptures on this island, consisting of gigantic stone images in great numbers. The greater part of the island belongs to an Englishman, and is utilized as a grazing farm for sheep and cattle. The inhabitants now number only about 150, the bulk of them having recently been transported elsewhere.

Eastern Archipelago. See *Malay Archipelago*.

Eastern Churches, a collective term for the Greek, Armenian, Coptic, Abyssinian, Syrian, and other kindred churches.

Eastern Empire. See *Byzantine Empire*.

Eastern Question, the name given to the diplomatic and national interests affected by the gradual retrocession of the Turkish Empire in Europe, and the problem of disposing of the territory thus left, or presumably to be left. Bulgaria, Roumania, Servia, and Greece are the new states which have naturally arisen on the withdrawal of the Turkish power, and their history in connection with the respective policies of England, France, Austria, and Russia towards them is the history of the phases of the 'Eastern Question' so far. The Crimean war of 1854-56 with the Treaty of Paris which followed after it, and the Russo-Turkish war of 1877-78 with the Treaty of Berlin, are amongst the notable events connected with this subject.

Eastern Roumelia, a portion of the Turkish dominions in Europe lying on the south of Bulgaria, from which it is separated by the Balkan Mountains; area, 13,500 sq. miles. The country is fertile, but agriculture is backward; wheat, wine, tobacco, &c., are produced; timber is abundant. The chief town is Philippopolis. E. Roumelia was constituted an autonomous province of Turkey by the Treaty of Berlin in 1878, but recently attached itself to Bulgaria. (See *Bulgaria*.) Pop. 975,000.

Easter Term, in England, a term for law sittings, &c., beginning on the 30th April, and continuing till about the end of May or early in June—in the English universities a term held in the spring, and lasting for about six weeks.

East India Company, a great English company, originally simply a trading association, which played an important part in the history of Hindustan. It was formed in 1599 in London, with a subscribed capital of about £30,000, for the purpose of trade with the East Indies. A charter was granted to it by Queen Elizabeth on 31st December,

EAST INDIA COMPANY.

1600, for fifteen years, renewable for a similar period. In this charter the company is styled, 'The Governor and Company of the Merchants of London trading into the East Indies.' The first voyages resulted in large profits. The illustration represents what is be-

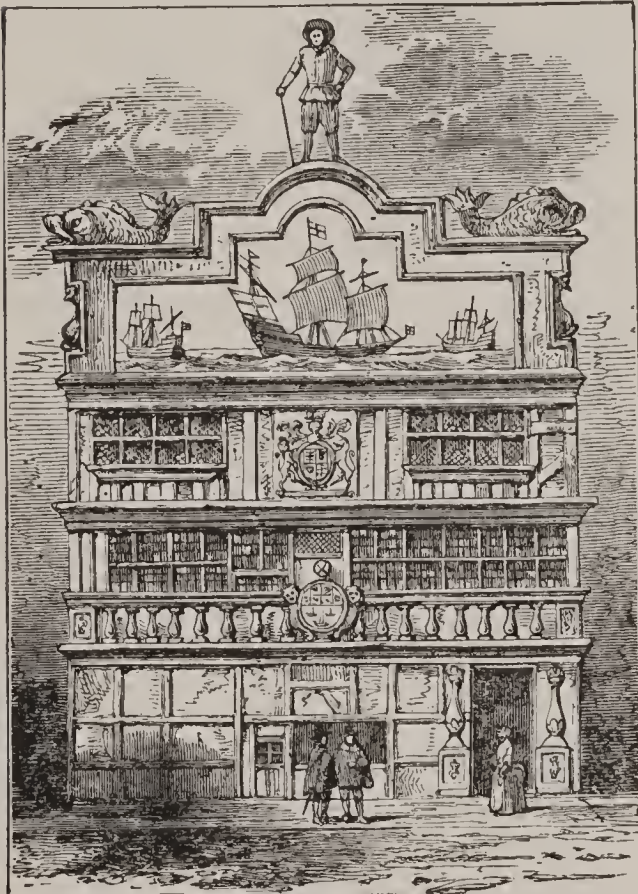

The Old East India House, Leadenhall Street (1650).

lieved to have been the original head-quarters of the company, from a unique engraving in the British Museum. In 1609 the charter was renewed by James I., and made perpetual, reserving power to the crown to recall it at three years' notice. Additional power was granted to the Company of seizing and confiscating ships and goods of contraband traders, either in the British dominions or in any of the places where they were authorized to trade. Among the motives which had induced the Company to press for this renewal of their charter was the necessity they had experienced from the jealousy of the Dutch and Portuguese to send out vessels fitted not only for trade, but for defence and indeed attack. Accordingly Captain Best, who commanded the eighth expedition, attacked four Portuguese war galleons, convoying 200 sail of merchantmen, off Surat, and gained a complete victory, which so impressed the Great Mogul that he immediately made a treaty

with Captain Best, giving the English full liberty to trade in his dominions. This treaty was concluded on 6th Feb. 1613. It was followed at once by a resolution of the Company to trade on a joint-stock. £429,000 was raised as capital, and apportioned in fitting out four voyages for 1613, 1614, 1615, 1617. In 1617-18 the Company was so enlarged as to include 954 proprietors, while a new joint-stock of £1,600,000 was subscribed. In 1619 a treaty was made with the Dutch, by which the two companies were to work in harmony for twenty years; but in 1629 the Dutch massacred the leading members of the English factory at Amboyna. In the feeble reigns of James and Charles I., however, the outrage remained unredressed, and the English Company, ill supported by the crown, was often reduced to great straits. Their trade, impeded by the Dutch, became unprofitable, and, to add to their difficulties, Charles I. in 1635 gave a license to a rival company. At length, under Cromwell, the Company received a new charter. A territorial footing had been acquired in Madras in 1640, to which settlement was given the control of all the factories in Bengal and the Coromandel coast, the supreme council in India still remaining at Surat. A new charter, granted by Charles II. in 1660, enlarged the powers of the Company, giving it political and judicial authority in the factories and colonies established by it, with the right to appoint governors. On the Revolution of 1688 the Company was involved in new difficulties, and in 1692 the Commons presented an address to the crown praying for their dissolution. At this time, by an accidental failure to pay a tax upon their stock, the Company formally forfeited their charter, and were compelled to accept its renewal with the important proviso of a reservation to the crown of the right to alter or modify its conditions. The maximum stock to be held by any individual was fixed at £10,000, every £1000 of which was to give a vote, while the right of membership was thrown open to all British subjects. The Scottish Parliament also sanctioned a company, but a war with Spain and the bitter opposition of the English Parliament made difficulties under which this company succumbed. Meantime the misconduct of the English company had so strengthened its enemies, that, in spite of all its opposition, a resolution in favour of the formation of a new company passed the

House of Commons on 4th May, 1698, and this company was actually constituted by Act 9 William III. cap. xlv. This act provided for the extinction of the old company, but an amalgamation was eventually arranged in 1708. The possessions of the old company at the time of amalgamation, upon which the valuation of £330,000 was placed in 1700, included a large number of places in India, a footing having been by this time acquired in each of the three presidencies, besides possessions in Persia, Cochin-China, Sumatra, &c. The dividends of the Company rose rapidly after the amalgamation, and finally settled at 8 per cent; and it procured without difficulty, at various periods, a prolongation of its exclusive privileges until 1780, still with three years' notice. In the meantime the French possessions had, as well as the English, been growing in power and importance in the East, and on the outbreak of the war of the Austrian Succession in 1741 commenced those struggles (Clive being the first great English leader) by which a mercantile company was led on to establish British supremacy over nearly the whole of India. (See *India*.) In 1766 the right of the Company to acquire territorial possessions formed a subject of parliamentary inquiry; and the question of the political rights of the Company being thus opened up, the ministry began to act on their view of it by sending out a crown plenipotentiary to India. A regulating act was passed in 1773 remodeling the powers of the Company, and placing it completely under the control of parliament, providing for the establishment by the crown of courts of judicature in India. The charter, which expired in 1780, was renewed till 1791. The renewal act provided that the Company, which was already bound to submit to the government all despatches received from India, should submit for approval all despatches proposed to be transmitted thither. In 1784 another act established a board, afterwards known as the board of control, to superintend, direct, and control all acts, operations, and concerns relating to the civil and military government or revenues of India. The board was to consist of a principal secretary of state, the chancellor of the exchequer, and four privy-councillors nominated by the crown. The directors of the Company were bound to submit all their papers except those referring to commercial matters to this board, and obey its instructions. From

this time the political power of the Company was little more than nominal. While the right of nominating the servants of the Company was still left to the directors, the absolute right of recall was vested in the crown. A subsequent declaratory bill regulated the power of the board of control to send out troops at the expense of the Company. In 1813 the charter was renewed on condition that the right of exclusive trade should be restricted to China, while the India trade should be thrown open to all British subjects. A church establishment for India was also provided by this act. The appointment of governors-general, governors, and commanders-in-chief was no longer to be valid without the direct sanction of the crown. The renewal of the Company's charter in 1834 took place amid continued opposition to their mercantile, and even to their legislative privileges. It continued them in all their possessions except the island of St. Helena, put an end to the exclusive right of trade with China, and enacted that the Company should with all convenient speed close their commercial business, and make sale of all their property not retained for government purposes; all their other property was to be held in trust for the crown, which was to take over their debts and guarantee their dividend out of the revenues of India. The stock was valued at £6,000,000, which was to bear interest at 10 per cent, and be redeemable after 30th April, 1874, on payment of £12,000,000. The Company was now fairly in liquidation, and on the outbreak of the mutiny of 1857 it was felt indispensable to vest the government of India directly in the crown, and this was accordingly done in 1858. Henceforth the Company existed only for the purpose of receiving payment of its capital, and of the dividends due upon capital until its repayment.

East Indies, the name loosely applied to Hindustan, the Indo-Chinese peninsula, and a portion of the Eastern Archipelago, but excluding the Philippine Islands, New Guinea, and Australia.

Eastlake, SIR CHARLES LOCK, English painter, President of the Royal Academy, born at Plymouth 17th November, 1793. He studied at the Royal Academy, London, and at Paris. In 1817 he visited Italy and Greece, and painted besides other pictures his *Pilgrims arriving in sight of Rome*. In 1830 he was elected member of the Royal Academy, and in 1850 became its

president, receiving at the same time the honour of knighthood. In 1843-47 he was keeper of the National Gallery, of which he was latterly director for about ten years. Sir Charles is also known as a writer on art by his *Materials for a History of Oil-painting*. He died at Pisa 23d December, 1865.

East Liverpool, O., a city in Columbi-ana co., 44 miles N. W. of Pittsburg; has two National banks, two weekly papers, manufactories, potteries, &c. Pop. 10,956.

East London, a seaport on the east coast of Cape Colony, at the mouth of the Buffalo river. Pop. 15,600.

East Providence, R. I. Pop. 1890, 8422.

Easton, a city of Pennsylvania, U. S., at the junction of the Delaware and Lehigh rivers. It contains iron-foundries, tanneries, breweries, &c. Pop. 1890, 14,481.

East Portland, Multnomah co., Oregon. Pop. 1890. 10,532.

East River, a strait in New York state, separating New York from Brooklyn and connecting Long Island Sound with New York Bay, about 20 miles long. A great suspension-bridge crosses between New York and Brooklyn.

East Saginaw, a city of Michigan, U. States, on the navigable river Saginaw, about 17 miles from its mouth in Saginaw Bay (Lake Huron), nearly opposite Saginaw. It has a large trade and important manufacturing industries. See *Saginaw* (consol).

Eastward Position, the position assumed by many clergymen of the Anglican Church during part of the communion service, the clergyman being placed in front of the communion table with his back to the congregation.

East St. Louis, a city of St. Clair co., Ill., opposite St. Louis, Mo., with which it is connected by R. R. bridge. Several factories and the largest stock yard in the country. Pop. 1890, 15,169.

Eau (ō), a French word signifying *water*, and used in English with some other words for several spirituous waters, particularly perfumes, as *eau de Cologne*, *eau de Luce*, &c.—*Eau de Cologne* is a fragrant water, made originally and in most perfection in Cologne by a manufacturer named Farina, by whose successors the only genuine water is said still to be manufactured. It consists of spirits of wine flavoured by different essential oils blended so as to yield a fine fragrant scent.—*Eau Créole*, a highly-esteemed liqueur made in Martinique by distilling the flowers of the mammee apple with spirit of

wine.—*Eau de Luce* ('water of Luce'), so called from the name of its inventor, is made by dissolving white soap in spirit of wine, and adding oil of amber and sal ammoniac. It is a milky fluid, antispasmodic and stimulant.—*Eau de Vie* ('water of life'), a term used by the French for the coarser kinds of brandy, *cognac* being the name of the best.

Eau Claire (ō klār), a city of Wisconsin, U.S., at the junction of the Eau Claire and Chippewa rivers, a great lumbering centre. Pop. 17,415.

Eaux-bonnes (ō-bon), a watering-place, France, department Basses Pyrénées, about 25 miles south of Pau. The hot sulphur springs are said to have great efficacy in affections of the chest. Pop. 1000.—Near it is *Eaux Chaudes*, also with warm springs.

Eaves-dropper, one who stands under the eaves or near the window or door of a house to listen and hear what is said within doors. In English law an eaves-dropper is considered as a common nuisance and is punishable by fine.

E'bal, a mountain of Western Palestine about half-way between Jerusalem and Nazareth, on the north side of a narrow valley, on the south side of which and directly opposite stands Mt. Gerizim with Nablous almost between. Here the Israelites set up an altar on their entrance into the Holy Land and had the law solemnly read to them by Joshua (Jos. viii. 30-35). At the east end of the valley are Jacob's Well and Joseph's Tomb.

Ebb. See *Tides*.

Ebbfleet, a hamlet in the Isle of Thanet, county Kent, memorable as the place where the first Anglo-Saxon invaders landed.

Ebbw-vale, a town of England, in Monmouthshire, with ironworks, steelworks, and collieries. Pop. 15,000.

Ebelians, a German sect originating at Königsberg in 1836 under the leadership of Archdeacon Ebel. They professed what they called spiritual marriage. In 1839 their leaders were condemned for unsound doctrine and impure lives.

Ebena'ceæ, a natural order of exogenous plants, consisting of trees and shrubs, of which the wood is very hard, and frequently of very dark colour in the centre, as ebony. The leaves are alternate, and generally coriaceous and shining; calyx monosepalous and persistent, with three or six equal divisions; corolla monopetalous, with imbricated divisions. The fruit is a globular berry con-

taining a small number of compressed seeds. The principal genus is *Diospyros*, which yields ebony and iron-wood. See *Ebony*.

Ebers (ā'bērz), GEORG MORITZ, German Egyptologist and novelist, born 1st March 1837 at Berlin; studied at Göttingen, and afterwards at Berlin, where he devoted himself to Egyptology. In 1870 he was made professor at the University of Leipzig, a post which he still holds. He has made more than one visit to Egypt. His most important works have been translated into English, such as *Egypt, Descriptive, Historical, and Picturesque*, and the novels, *An Egyptian Princess*, *Uarda*, *Homo Sum*, *The Emperor*, *The Sisters*, all dealing with old Egyptian life; *The Burgomaster's Wife*, *Only a Word*, &c.

E'bionites, a sect of the 1st century, so called from their leader, Ebion. They held several dogmas in common with the Nazarenes, united the ceremonies of the Mosaic institution with the precepts of the gospel, and observed both the Jewish Sabbath and Christian Sunday. They denied the divinity of Christ and rejected many parts of the New Testament.

Eblis, in Mohammedan mythology, the chief of the evil spirits.

Eb'oli, a town of Southern Italy, prov. Salerno. Pop. 8405.

Eb'onite. See *Vulcanite*.

Eb'ony, the popular name of various plants of different genera, agreeing in having wood of a dark colour. The best-known ebony is derived from plants of the genus *Diospyros*, nat. order Ebenaceæ. The most valuable is the heart-wood of *D. Ebēnus*, which grows in great abundance in the flat parts of Ceylon, and is of such size that logs of its heart-wood 2 feet in diameter and from 10 to 15 feet long are easily procured. Other varieties of valuable ebony are obtained from *D. Ebenaster* of the East Indies and *D. melanoxylon* of Coromandel. Ebony is hard, heavy, and durable, and admits of a fine polish or gloss. The most usual colour is black, red, or green. The best is jet black, free from veins, very heavy, astringent, and of an acrid



Ebony (*Diospyros Ebenus*).

pungent taste. On burning coals it yields an agreeable perfume, and when green it readily takes fire from its abundance of fat. It is wrought into toys, and used for mosaic and inlaid work.

E'bro (Latin, *Ibērus*), a river in Spain, which has its source in the province of Santander, about 25 miles s. of the Bay of Biscay, and after a south-easterly course of about 500 miles enters the Mediterranean. Its navigation is much interrupted by rapids and shoals, to avoid which a canal about 100 miles long has been constructed nearly parallel to its course.

Ebullition, the boiling of a fluid. See *Boil*.

Écarté (ā-kār'tā), a game at cards for two persons played with thirty-two cards, the small cards from two to six being excluded. In the English mode of playing the game the players cut for the deal, which is decided by the lowest card. The dealer gives five cards to either player, three and two at a time, and turns up the eleventh card for trump. If he turns up a king he scores one, and if a king occurs in the hand of either player he may score one by announcing it before the first trick. The cards rank as follows: king (highest), queen, knave, ace, ten, &c. The non-dealer leads; trumps take all other suits, but the players must follow suit if they can. Three tricks count one point, five tricks two points; five points make game. Before play begins the non-dealer may claim to discard (*écarter*) any of the cards in his hand, and have them replaced with fresh ones from the pack. This claim the dealer may or may not allow. Should he allow he can discard as many as he pleases. Sometimes only one discard is allowed, sometimes more.

Ecbat'ana, the chief city or ancient metropolis of Media, the summer residence of the Median and Persian and afterwards of the Parthian kings. It was a place of great splendour at an early period. Its site can no longer be fixed with certainty, though many explorers agree in identifying it with the modern Hamadan.

Ecce Homo (ek'sē; Latin, 'Behold the man!'), a name often given to crucifixes and pictures which represent Christ bound and crowned with thorns.

Eccen'tric, a term in mechanics applied to contrivances for converting circular into reciprocating (backwards and forwards) rectilinear motion, consisting of variously-shaped discs attached to a revolving shaft

not in their centre. An *eccentric wheel* is a wheel fixed on an axis that does not pass through the centre. Its action is that of a

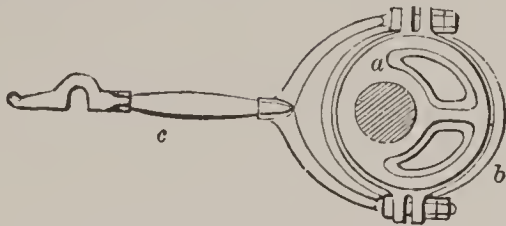

Eccentric of Steam-engine.

a, Eccentric-wheel; b, eccentric-strap; c, eccentric-rod.

crank of the same length as the eccentricity.

Ecchymosis (ek-ki-mō'sis) is the medical term applied to the extravasation of blood beneath the skin, or in the tissues of the body, whether resulting from a bruise or any other cause.

Eccles, a town of England, in Lancashire, 4 miles from Manchester, of which it may be considered a suburb. Pop. 11,143.

Ecclesias'tes (-tēz), the title by which the Septuagint translators rendered the Hebrew *Cohemoth* ('the gatherer of the people'), a symbolic name explained by the design of the book and the dramatic position occupied by Solomon in it, one of the canonical books of the Old Testament. According to Jewish tradition it was written by Solomon; but the best modern criticism has decided that its style and language, no less than its thought, belong to a much later date.

Ecclesiastical Commissioners, in England, a body corporate with extensive powers in regard to the organization of the church, the distribution of episcopal duties, the formation of parishes, &c. It consists of all the bishops of England and Wales, five cabinet ministers, three judges, and others. Their decisions are ratified by orders in council, and acquire the force of acts of parliament.

Ecclesiastical Corporations (English law), corporations created for the furtherance of religion, and for the perpetuation of the rights of the church, the members of which are exclusively spiritual persons.

Ecclesiastical Courts, courts in which the canon law is administered and in which ecclesiastical causes are determined. In England they are the *Archdeacon's Court*, the *Consistory Courts*, the *Court of Arches*, the *Court of Peculiars*, the *Prerogative Courts of the two archbishops*, the *Faculty Court*, and the *Privy-council*, which is the court of appeal, though its jurisdiction may by order

in council be transferred to the new Court of Appeal. In Scotland the ecclesiastical courts are the *Kirk-session*, *Presbytery*, *Synod*, *General Assembly* (which is the supreme tribunal as regards doctrine and discipline), and the *Teind Court*, consisting of the judges of the Court of Session, which has jurisdiction in all matters affecting the teinds of a parish.

Ecclesias'ticus, the title of a book placed by Protestants and Jews among the apocryphal writings. The author calls himself Jesus the son of Sirach. Originally composed in Aramaic, the book was translated into Greek by the grandson of the original author about the 3d century B.C.

Ecclesiol'ogy, the science or branch of knowledge which deals with ecclesiastical antiquities, such as buildings, rites, vestments, &c.

Echalot (esh'a-lot). See *Shallot*.

Échelles, LES (lā-zā-shāl; 'the Ladders'), a village, France, dep. Savoie, 12 miles southwest of Chambéry, in a valley from which egress at one end was formerly by means of ladders, but now by a tunnel. Pop. 798.

Echelon (esh'e-lon), the position of an army when its different positions are somewhat in the form of steps, or with one division more advanced than another, being parallel and none of them in line.

Echeneis (ek-e-nē'is), a genus of fishes, family Scomberidæ or mackerels, having a disc on the head by which the fish can attach itself firmly to a solid object. *E. Remora* is abundant in the Mediterranean. See *Remora*.

Echeveria (ech-e-vē'ri-a), a genus of succulent plants, order Crassulaceæ (house-leek), chiefly natives of Mexico, but now cultivated in European and other gardens and greenhouses, some for their flowers, others for their foliage.

Echidna (ē-kid'na), a genus of Australian monotrematous, toothless mammals, in size and general appearance resembling a large hedgehog, excepting that the spines are longer, and the muzzle is protracted and slender, with a small aperture at the extremity for the protraction of a long flexible tongue. The habits of the Echidna are nocturnal; it burrows, having short strong legs with five toes, and feeds on insects, which it catches by protruding its long sticky tongue. It is nearly allied to the Ornithorhynchus, the two forming a peculiar class of animals, having in their structure some peculiarities at once of mammals, birds, and

reptiles. In 1884 it was found, that, as Geoffroy St. Hilaire had suspected, the echidna and ornithorhynchus, although essentially mammals, were yet oviparous, producing their young from eggs. One species (*E. hystrix*), from its appearance, is popularly known as the *porcupine ant-eater*.

Echimys (e-kī'mis), a genus of South American rodent quadrupeds corresponding in some of their characters with dormice, but having the tail scaly and the fur coarse and mingled with flattened spines.

Echinite (e-kī'nīt), a fossil sea-urchin.

Echinocactus (e-kī'-), a genus of cactaceous plants inhabiting Mexico and South America, and remarkable for their peculiar forms, being globular, oblong, or cylindrical, and without leaves, fluted and ribbed, with stiff spines clustered on woolly cushions. Some of them are very bulky. The flowers are large and showy. See *Cactus*.

Echinococcus (e-kī'-), one of the larval forms (*scolicēs*) of the tape-worm of the dog (*Tenia Echinococcus*), which may occur in man and cause serious disease.

Echinodermata (e-kī-nō-dér'ma-ta), a class or sub-kingdom of invertebrate animals characterized by having a tough integument in which lime is deposited in granules (as in the star-fish and sea-cucumber), or so as to form a rigid test or shell like that of the sea-urchin; and by the radial arrangement of many of the parts of the adult, though this is not necessarily carried out in the digestive and reproductive systems. They are provided with an apparatus for water circulation opening into the *ambulacra* or tubular feet, which are put into use by being distended with fluid. Some of them, as the encrinites or sea lilies, are permanently fixed by a stalk when adult. Their development is accompanied with metamorphosis, and the embryo shows a distinctly bilateral aspect, though the radiate arrangement prevails in the adult. By some they are classed with the Scolecida in the sub-kingdom Annuloida. The sexes are distinct. The class is divided into seven orders: the Echinoidea (sea-urchins), Asteroidea (star-fishes), Ophiuroidea (sand-stars and brittle-stars), Crinoidea (feather-stars, encrinites, &c.), Cystidea (extinct), Blastoidea (extinct), and Holothuroidea (sea-cucumbers). All are marine.

Echinus (e-kī'nus), SEA-URCHIN, or SEA-EGG, a genus of marine animals, the type of an order (Echinoidea) of the class Echinodermata (see above). The body is more or

less globular and covered with a test or shell, often beset with movable spines. Locomotion is effected by a singular system of ambulacra or 'tube-feet,' which are distended with water, protruded through pores, and again retracted. The mouth is situated on the inferior surface, generally in the centre, is armed with calcareous teeth, and opens into a gullet conducting to a distinct stomach. The stomach has issue into a convoluted intestine which winds round the interior of the shell and terminates in a distinct anus. The anus varies in position, being sometimes on the apical disc and sometimes marginal. The *E. esculentus* and some other species are edible.

Echinus (e-kī'nus), in architecture, the *ovolo* or quarter-round convex moulding, seen in capitals of the Doric order. It is especially frequently found carved with the egg-and-dart ornament.

Echo (ek'ō), the repetition of a sound caused by the reflection of sound-waves at some moderately even surface, as the wall of a building. The waves of sound on meeting the surface are turned back in their course according to the same laws that hold for reflection of light. In order that the echo may return to the place from which the sound proceeds the reflection must be direct, and not at an angle to the line of transmission, otherwise the echo may be heard by others but not by the transmitter of the sound. This may be effected either by a reflecting surface at right angles to the line of transmission, or by several reflecting surfaces which end in bringing the sound back to the point of issue. Sound travels about 1125 feet in a second; consequently, an observer standing at half that distance from the reflecting object would hear the echo a second later than the sound. Such an echo would repeat as many words and syllables as could be heard in a second. As the distance decreases the echo repeats fewer syllables till it becomes monosyllabic. The most practised ear cannot distinguish in a second more than from nine to twelve successive sounds, so that a distance of not less than 60 feet is needed to enable a common ear to distinguish between the echo and the original sounds. At a near distance the echo only clouds the original sounds, and this often interferes with the hearing in churches and other large buildings. Woods, rocks, and mountains produce natural echoes in every variety, for which particular localities have become famous.—In Greek mythol. Echo was a nymph (one of the Oreads) who

fell in love with Narcissus, and because he did not reciprocate her affection she pined away until nothing was left but her voice.

Echuca (e-chö'ka), a rising Australian town, colony of Victoria, on the Murray, over which is an iron railway and roadway bridge, connecting it with Moama in N. S. Wales; trade (partly by the river) in timber, wool, &c. Pop. 4789.

Ecija (ā'thē-há), an ancient town of Southern Spain, province of Seville, on the Genil, with manufactures of textile fabrics and a good trade. It is one of the hottest places in Spain. Pop. 24,955.

Eck, JOHANN MAYR VON, the celebrated opponent of Luther, born in 1486. Having obtained a reputation for learning and skill in disputation he was made Doctor of Theology, canon in Eichstädt, and pro-chancellor of the University of Ingolstadt. He went to Rome in 1520 and returned with a papal bull against Luther, in attempting to publish which he met with violent popular opposition. In 1530, while at the diet of Augsburg, he made the remarkable admission that he could confute the Augsburg Confession by the fathers but not by the Scriptures. Eck was present also at the diets of Worms (1540) and Ratisbon (1541). He died in 1543.

Eck'ermann, JOHANN PETER, German writer, born in 1792. In 1813 he served in the army against the French, and was afterwards appointed to a small governmental post. He finally settled in Weimar, where he became private secretary to Goethe. After Goethe's death he published his *Conversations with Goethe*. He died in 1854.

Eclectic, or NEW SCHOOL OF MEDICINE, as distinct from the 'regulars,' originated about 1825 in New York. It rejects mercury and most other minerals in medicine, practising simple hygienic treatment, adding largely to the list of vegetable medicines. The school numbers over 15,000 physicians in the U. States.

Eclectic's (Greek, *eklektikos*, select) is a name given to all those philosophers who do not follow one system entirely, but select what they think the best parts of all systems. In this century the eclectic method found a notable supporter in the French philosopher Victor Cousin.

Eclipse (ek-lips'; Greek, *ekleipsis*, a failing, *ekleipō*, to fail), an interception or obscuration of the light of the sun, moon or other heavenly body by the intervention of another and non-luminous heavenly body. Stars and planets

may suffer eclipse, but the principal eclipses are those of the sun and the moon.

An Eclipse of the Moon is an obscuration of the light of the moon occasioned by an interposition of the earth between the sun and the moon; consequently, all eclipses of the moon happen at full moon; for it is only when the moon is on that side of the earth which is turned away from the sun, and directly opposite, that it can come within the earth's shadow. Further, the moon must at that time be in the same plane as the earth's shadow; that is, the plane of the ecliptic in which the latter always moves. But as the moon's orbit makes an angle of more than 5° with the plane of the ecliptic, it frequently happens that though the moon is in opposition it does not come within the shadow of the earth. The theory of lunar eclipses will be understood from fig. 1, where S represents the sun, E the earth, and M the moon. If the sun were a point of light there would be a sharp outlined shadow or *umbra* only, but since the luminous surface is so large there is always a region in which the light of the sun is only partially cut off by the earth, which region is known as the *penumbra* (P P). Hence during a lunar eclipse the moon first enters the penumbra, then is totally eclipsed by the umbra, then emerges through the penumbra again.

An Eclipse of the Sun is an occultation of the whole or part of the face of the sun occasioned by an interposition of the moon between the earth and the sun; thus all eclipses of the sun happen at the time of new moon. Fig. 2 is a diagram showing the principle of a solar eclipse. The dark or central part of the moon's shadow, where the sun's rays are wholly intercepted, is here the *umbra*, and the light part, where only a part of them are intercepted, is the *penumbra*; and it is evident that if a spectator be situated on that part of the earth where the umbra falls there will be a total eclipse of the sun at that place; in the penumbra there will be a partial eclipse, and beyond the penumbra there will be no eclipse. As the earth is not always at the same distance from the moon, and as the moon is a comparatively small body, if an eclipse should happen when the earth is so far from the moon that the moon's shadow falls short of the earth, a spectator situated on the earth in a direct line between the centres of the sun and moon, would see a ring of light round the dark body of the moon;

ECLIPSE — ECLIP'TIC.

such an eclipse is called *annular*, as shown in fig. 3; when this happens there can be no total eclipse anywhere, because the moon's umbra does not reach the earth. An eclipse can never be annular longer than 12 minutes 24 seconds, nor total longer than 7 minutes 58 seconds; nor can the entire duration of an eclipse of the sun ever exceed 2 hours.

An eclipse of the sun begins on the western side of his disc and ends on the eastern;

and an eclipse of the moon begins on the eastern side of her disc and ends on the western. The average number of eclipses in a year is four, two of the sun and two of the moon; and as the sun and moon are as long below the horizon of any particular place as they are above it, the average number of visible eclipses in a year is two, one of the sun and one of the moon.

Eclip'tic, the sun's path, the great circle

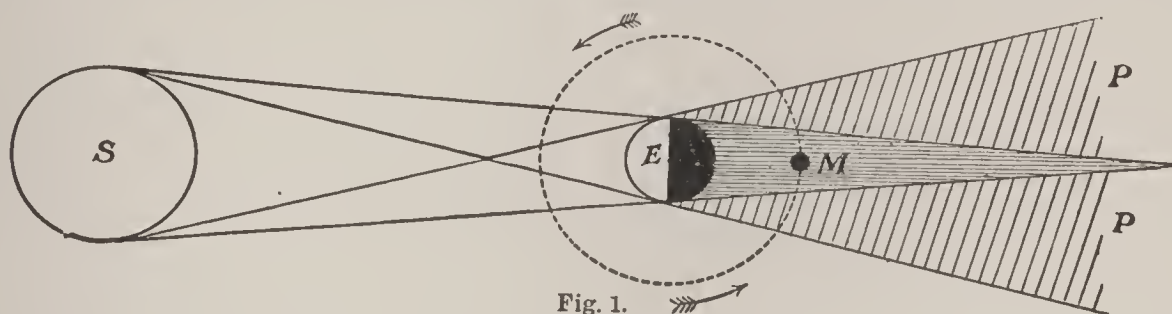

Fig. 1.

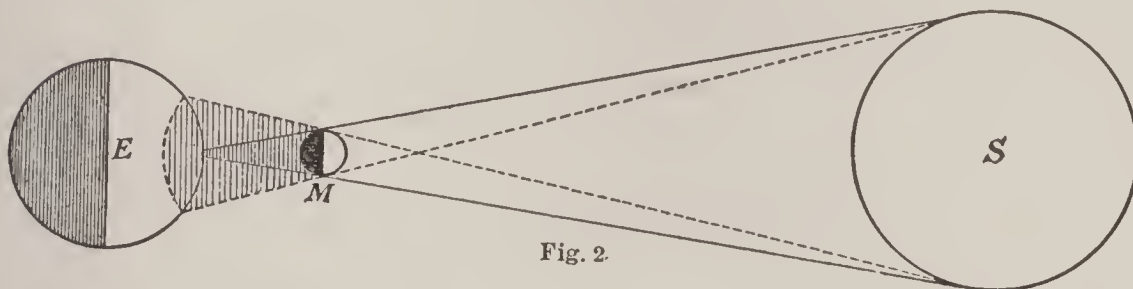

Fig. 2.

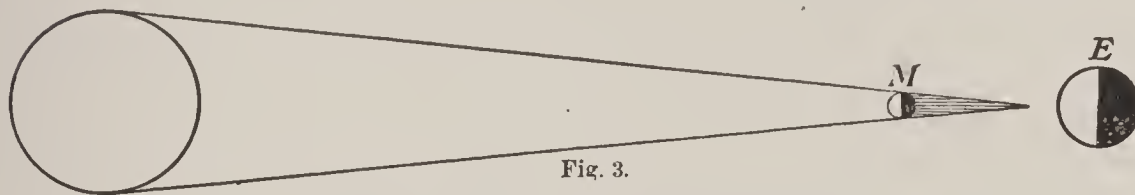

Fig. 3.

Diagrams illustrating the Theory of Eclipses.

of the celestial sphere, in which the sun appears to describe his annual course from west to east—really corresponding to the path which the earth describes. (See *Earth*.) The Greeks observed that eclipses of the sun and moon took place near this circle; whence they called it the *ecliptic*. The ecliptic has been divided into twelve equal parts, each of which contains 30 degrees, and which are occupied by the twelve celestial signs or constellations, viz.:

- ♈ Aries (the Ram), March 20.
- ♉ Taurus (the Bull), April 20.
- ♊ Gemini (the Twins), May 21.
- ♋ Cancer (the Crab), June 21.
- ♌ Leo (the Lion), July 22.
- ♍ Virgo (the Virgin), August 23.
- ♎ Libra (the Balance), September 23.
- ♏ Scorpio (the Scorpion), October 23.
- ♐ Sagittarius (the Archer), Nov. 22.

♑ Capricornus (the Goat), Dec. 21.

♒ Aquarius (the Water-carrier), Jan. 19.

♓ Pisces (the Fishes), February 18.

These are also called signs of the *zodiac*, the zodiac being a belt of the heavens extending 9 degrees on each side of the ecliptic. The days of the month annexed show when the sun, in its annual revolution, enters each of the signs of the zodiac. From the first point of Aries, or the place of the sun at the vernal equinox, the degrees of the ecliptic are counted from west to east. The plane of the ecliptic is that by which the position of the planets and the latitude and longitude of the stars are reckoned. The points at which the equator and ecliptic intersect are subject to a continual variation, receding westwards at the rate of about 50 seconds a year. The angle at which the ecliptic stands to the equator is also vari-

able, and has been diminishing for about 4000 years at the rate of about 50 seconds in a century. Laplace showed, however, that this variation has certain fixed limits, and that after a certain time the angle will begin to increase again. The combined result of these two changes is to cause the pole of the earth not to point constantly to the same spot in the heavens, but to describe an undulating circle round a certain point; but this movement is so slow that it takes many thousand years to complete it. See *Nutation* and *Precession*.

Eclogue (ek'log), a term usually applied to what Theocritus called *idyls*—short, highly-finished poems, principally of a descriptive or pastoral kind. See *Idyl*.

École des Beaux Arts ('School of Fine Arts'), the French government school of fine arts at Paris, founded by Mazarin in 1648, and provided with an extensive staff of teachers. The competitions for the *grands prix de Rome* take place at this school. All artists between the ages of fifteen and twenty-five, whether pupils of this school or not, may compete, after passing two preliminary examinations. The successful competitors receive an annual allowance from the state for three or four years, two of which must be passed at Rome.

École Normale Supérieure ('Superior Normal School'), a school at Paris for the training of those teachers who have the charge of the secondary education in France, founded by decree of the Convention in 1794, reorganized by Napoleon in 1808, and again in 1830 by the government of Louis-Philippe. It maintains a hundred students and has a course of three years' duration.

École Polytechnique ('Polytechnic School'), a school in Paris established with the purpose of giving instruction in matters connected with the various branches of the public service, such as mines, roads and bridges, engineering, the army and the navy, government manufactures, &c. It was founded in 1794, and is under the direction of the minister of war. Candidates are admitted only by competitive examination, and have to pay for their board 1000 francs (about £40) a year. The pupils who pass satisfactory examinations at the end of their course are admitted to that branch of public service which they select.

Écraseur (ā'krā-zeur), in surgery, an instrument consisting of a fine chain which is placed round the base of a growth or a tumour and gradually tightened by a screw

till it passes through the structure. It is used in cases of cancer of the tongue, polypi, &c.

Ec'tozoa, a term which has been introduced, in contradistinction to Entozoa, to designate those parasites, as lice, ticks, &c., which infest the external parts of other animals.

Ecuador (ek-wā-dōr'), a republic of South America, situated under the equator, whence it takes its name, between Peru and Colombia. It is of triangular shape, its base resting mainly on the Pacific, between lat. 1° 20' N. and 4° 50' S., its apex extending to about 71° 30' W. lon.; area, about 180,000 square miles, or including the Galapagos Islands, 182,950 square miles. The country is divided into a number of provinces, and falls, as regards the surface, into three sections: the comparatively narrow and low-lying coast regions, the mountain region, and the extensive plains on the east. The mountain region is formed by a double range of snow-clad mountains—several of them active volcanoes—which inclose a longitudinal valley or table-land, with a breadth of 20 to 40 miles, and varying in elevation from 8500 to 13,900 feet. The most elevated of these mountains are, in the western range, Chimborazo, Pichincha, and Cotacachi, Chimborazo being 20,703 feet high. In the eastern range are Cayambe, Antisana, and Cotopaxi (19,500). The cultivated land and the population of Ecuador lie chiefly in this elevated region, which extends along between the summits of the Cordillera, and may be considered as divided by transverse ridges or dikes into the valleys of Quito, Hambato, and Cuenca. The chief towns here are Quito, the capital, with a pop. of 80,000; Riobamba, and Cuenca, all situated at a height of 9000 feet or more above the sea. The chief ports of Ecuador are Guayaquil and Esmeraldas. The most considerable rivers, the Tigre, Napo, Pastaza, &c., belong to the basin of the Amazon; and some of them, notably the Napo, are navigable for long distances. On the western slope of the Andes the chief rivers are the Esmeraldas and the Guayaquil. Ecuador is comparatively poor in Mammalia; although various kinds of deer as well as tapirs and peccaries are found in the forests. Parrots and humming-birds are also numerous, but perhaps the most remarkable of the birds in Ecuador is the condor, which dwells on the slopes of the Andes. Reptiles, including serpents, are numerous. The forests yield

cinchona bark, caoutchouc, sarsaparilla, vegetable ivory, &c. The climate on the plains, both in the east and the west, is moist, hot, and unhealthy. In the higher regions the climate is rough and cold, but in great part the elevated valleys, as that of Quito, enjoy a delightful climate. Here the chief productions are potatoes, barley, wheat, and European fruits. In the lower regions are grown all the food-products of tropical climates, cacao, coffee, sugar, &c. The foreign commerce is not large, the exports and imports being annually about \$7,500,000 each. Cacao forms three-fourths (or more) of the whole export; the remainder is made up of coffee, hides, vegetable ivory, caoutchouc, &c. The mining and manufactures of Ecuador are insignificant. The people are poorly educated. The religion is exclusively Roman Catholic. The executive government is vested in a president elected for four years, who is assisted by a council of state. The congress is the legislative body, and consists of two houses, one formed of senators, two for each province, the other of deputies, one for every 30,000 inhabitants, both elected by universal suffrage. The congress has extensive privileges, and cannot be dissolved by the president. The seat of government is at Quito. In recent years the revenue and expenditure have been about \$4,000,000 to \$4,500,000 each. The total debt amounts to about \$11,000,000. The money unit is the *sucre*, equivalent to a 5-franc piece, but the coins of the U. States, France, and Britain circulate. Railways and telegraphs have made little progress.—Ecuador at the time of the conquest of Peru by the Spaniards formed part of the great empire of the Incas. It was erected first into a viceroyalty of Peru, then (from 1564 to 1718) into an independent presidency. From 1718 it became part of the presidency of New Granada. In the revolutionary war against Spain Ecuador, along with the neighbouring territories, secured its independence (1822), and was ultimately erected into a separate republic in 1831. Of the present population, the aboriginal red race form more than half; the rest are negroes, mulattoes, mestizoes, a degenerate breed of mixed negro and Indian blood, and Spanish Creoles or whites. The latter are the chief possessors of the land, but are deficient in energy. Pop. in 1890, 1,146,000.

Ecumenical Council, a general ecclesiastical council regarded as representing the whole Roman Catholic Church. The last

was held at Rome in 1870. There were present 803, including cardinals, archbishops, bishops, abbots, and generals of orders. After much discussion, and the withdrawal of a number of bishops, the infallibility of the pope as head of the church was affirmed and promulgated.

Ec'zema, a disease of the skin, marked by an eruption of small vesicles, preceded by redness, heat, and itching of the part. In course of time the minute vesicles burst, and discharge a thin acrid fluid, which often gives rise to excoriation. The most severe form of this disease arises from constitutional conditions, but purely local attacks are likewise caused by exposure of the skin to irritating substances.

Ed'am, a town of North Holland, near the Zuyder-Zee, 12 miles N.N.E. of Amsterdam. This place is chiefly noted for its trade in cheese and wood. Pop. 5267.

Edda (meaning 'great-grandmother'), the name given to two ancient Icelandic works, the one consisting of mythological poems, the other being mainly in prose. The first of these collections, called the Older or Poetic Edda, was compiled in the 13th century. For a long time an earlier date was given, the compiler being erroneously believed to have been Sæmund Sigfusson, a learned Icelandic clergyman, who lived from about 1056 to 1133. It consists of thirty-three pieces, written in alliterative verse, and comprising epic tales of the Scandinavian gods and goddesses, and narratives dealing with the Scandinavian heroes. These poems are now assigned to a period extending from the 9th to the 11th century. The prose Edda, or Younger Edda, presents a kind of prose synopsis of the Northern mythology; a treatise on the Scaldic poetry and versification, with rules and examples; and lastly a poem (with a commentary) in honour of Haco of Norway (died 1263). In its earliest form this collection is ascribed to Snorri Sturluson, who was born in Iceland in 1178, and was assassinated there in 1241 on his return from Norway, where he had been scald or court-poet.

Eddystone Lighthouse, a lighthouse in the English Channel, erected to mark a group of rocks lying in the fair way from the Start to the Lizard. The rocks are covered only at the flood. The first lighthouse was of wood, and built by Henry Winstanley in 1696. It was carried away in the storm of 1703. Another lighthouse, also of wood, was built in 1706 by Mr. Rudyerd, but was

burned down in 1755. It was succeeded by one built by Mr. Smeaton in 1757–59, a circular tower 85 ft. high; but as the foundations on which it stood became much weakened, a new structure, designed by Sir J. N. Douglass, was built in 1879–1882 on the neighbouring reef. Its light is visible 17½ miles.

Edelweiss (ā'dél-vīs; Ger. 'noble white'), *Gnaphalium Leontopodium* (or *Leontopodium alpinum*), a composite plant inhabiting the Alps, and often growing in the most inaccessible places. Its flower-heads are surrounded by a spreading foliaceous woolly involucre, and its foliage is also of the same woolly character. It is not difficult to cultivate, but is apt to lose its peculiar woolly appearance.

E'den, the original residence of the first human pair. It is said to have had a garden in the eastern part of it, and we are told that a river went out of Eden to water this garden, and from thence it was parted into four heads, which were called respectively Pison, Gihon, Hiddekel, and Euphrates (Phrat), but this does not enable us to identify the locality. It was not the whole of Eden that was assigned to man for his first habitation, but the part towards the east, to which the translators of the Authorized Version have given the name of the Garden of Eden, and which Milton, in *Paradise Lost*, calls Paradise, that word (originally Persian) having in its Greek form (*paradeisos*) been applied to the Garden of Eden by the translators of the Septuagint.

Eden, a river in England, in Westmoreland and Cumberland, falling into the Solway Firth after a course of 65 miles.—Also, a river in Fifeshire, Scotland.

Edenta'ta (ē-), or TOOTHLESS ANIMALS, the

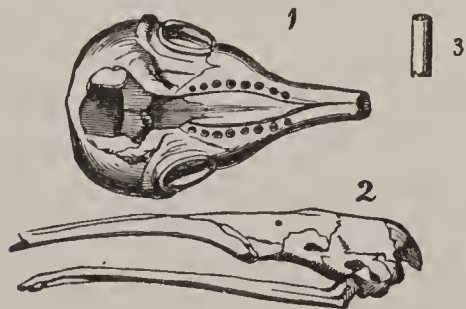

1, Skull and (3) Tooth of *Chlamyphorus truncatus* (a small species of armadillo). 2, Skull of *Myrmecophaga jubata* (Great Ant-eater).

name of an order of Mammalia, though only two genera of the order want teeth, the ant-eaters and the pangolins. The remainder

are merely destitute of teeth in the front of the jaws. The teeth they possess, however, are destitute of enamel, do not have complete roots, and are not replaced by a second set. This order is also characterized by the presence of great claws surrounding the ends of the toes, and more or less approximating to the nature of hoofs. It is divided into two sections, the first comprehending the sloths, which subsist on vegetable food, and the gigantic fossil animals the Megatherium and the Megalonyx; and the second including the armadillos and the ant-eaters, which live mainly on insects, though some of the armadillos eat other sorts of animal food, and also vegetables.

Edes'sa, the name of two ancient cities.—

1. The ancient capital of Macedonia, and the burial-place of its kings, now *Vodhena*. It is probably the same with the still more ancient Aegæ.—2. An important city in the north of Mesopotamia, which, subsequent to the establishment of Christianity, became celebrated for its theological schools. In 1098, in the first Crusade, Edessa came into the hands of Baldwin, but ultimately became part of the Turkish Empire. It is thought to be the modern Urfah or Orfa.

Edfoo' (ancient, *Apollinopolis*), a village in Upper Egypt, on the left bank of the Nile, 54 miles S.S.E. of Luxor. It is now a poor place, but its ancient magnificence is attested by several remains, especially a temple, founded by Ptolemy Philopator (B.C. 181–145), the largest in Egypt after those of Karnak and Luxor.

Ed'gar (THE PEACEABLE), one of the most distinguished of the Saxon kings of England, was the son of King Edmund I. He succeeded to the throne in 959, and managed the civil and military affairs of his kingdom with great vigour and success. In ecclesiastical affairs he was guided by Dunstan, and he was a great patron of the monks. He died in 975, and was succeeded by his son Edward the Martyr.

Edgar Atheling, grandson of Edmund Ironside and son of Edward the Outlaw, was born in Hungary, where his father had been conveyed in infancy to escape the designs of Canute. After the battle of Hastings, Edgar (who had been brought to England in 1057) was proclaimed king of England by the Saxons, but made peace with William and accepted the Earldom of Oxford. Having been engaged in some conspiracy against the king he was forced to seek refuge in Scotland, where his sister

Margaret became the wife of Malcolm Canmore. Edgar subsequently was reconciled with William and was allowed to live at Rouen, where a pension was assigned to him. Afterwards with the sanction of William Rufus he undertook an expedition to Scotland for the purpose of displacing the usurper Donald Bane, in favour of his nephew Edgar, son of Malcolm Canmore, and in this object he succeeded. He afterwards took part in Duke Robert's unsuccessful struggle with Henry I., but was allowed to spend the remainder of his life quietly in England.

Edgehill, an eminence in Warwickshire, England, where was fought a bloody but indecisive battle October 23, 1642, between the Royalists under Charles I. and the forces of the Parliament under the Earl of Essex.

Edge-railway, a kind of way in which the wheels of the carriages run on the edge of iron rails. The wheels are confined to their path by flanges which project about an inch beyond their periphery.

Edgeworth, MARIA, a celebrated authoress, daughter of Richard Lovell Edgeworth of Edgeworthstown, co. Longford, Ireland; was born at Hare Hatch, near Reading, Berkshire, on January 1, 1767. Her first novel, *Castle Rackrent*, a tale of Irish life, published in 1801, immediately established her reputation. This was followed by a long series of novels, moral tales, popular tales, &c., amongst which may be mentioned *Belinda*, *Leonora*, *Enni*, *The Absentee*, *Helen*, &c. Deserving of mention also are Miss Edgeworth's collection of *Tales for Children*, and the *Series of Early Lessons*. She died on 21st May, 1849, at Edgeworthstown.

Edgewater, N. Y., is on Staten Island, near the village of Stapleton. It has various manufactories. It is inhabited chiefly by New York business men. Pop. 14,265.

Edible Birds' Nests. See *Birds'-nests*, *Edible*.

Edict, a public proclamation by a sovereign, a governor, or other competent official.

Edict of Nantes. See *Nantes*.

Ed'inburgh, the metropolis of Scotland, and one of the finest as well as most ancient cities in the British empire, lies within 2 miles of the south shore of the Firth of Forth. It is picturesquely situated, being built on three eminences which run in a direction from east to west, and surrounded on all sides by lofty hills except on the north,

where the ground slopes gently towards the Firth of Forth. The central ridge, which constituted the site of the ancient city, is terminated by the castle on the west, situated on a high rock, and by Holyrood House on the east, not far from which rise the lofty elevations of Salisbury Crags, Arthur's Seat (822 ft. high), and the Calton Hill overlooking the city. The valley to the north, once the North Loch, but now drained and traversed by the North British Railway, leads to the New Town on the rising ground beyond, a splendid assemblage of streets, squares, and gardens. The houses here, all built of a beautiful white freestone found in the neighbourhood, are comparatively modern and remarkably handsome. The principal streets of the New Town are Prince's Street, George Street, and Queen Street. From Prince's Street, which is lined by fine gardens adorned with Sir W. Scott's monument and other notable buildings, a magnificent view of the Old Town with its picturesque outline may be obtained. The principal street of the Old Town is that which occupies the crest of the ridge on which the latter is built, and which bears at different points the names of Canongate, High Street, Lawnmarket, and Castle Hill. This ancient and very remarkable street is upwards of 1 mile in length, rising gradually with a regular incline from a small plain at the east end of the town, on which stands the palace of Holyrood, and terminating in the huge rock on which the castle is built, 383 feet above sea-level. The houses are lofty and of antique appearance. Amongst the notable buildings are the ancient Parliament House, now the seat of the supreme courts of Scotland; St. Giles's Church or Cathedral, an imposing edifice in the later Gothic style, recently carefully restored; the Tron Church; Victoria Hall (where the General Assembly of the Established Church meets), with a fine spire; the Bank of Scotland; &c., besides some of the old family houses of the Scottish nobility and other buildings of antiquarian interest. From this main street descend laterally in regular rows numerous narrow lanes called *closes*, many of them extremely steep, and very few at their entrances more than 6 feet wide; those which are broader, and admit of the passage of carriages, are called *wynds*. In these and the adjacent streets the houses are frequently more than 120 feet in height, and divided into from six to ten stories, or *flats*, the communication between which is main-

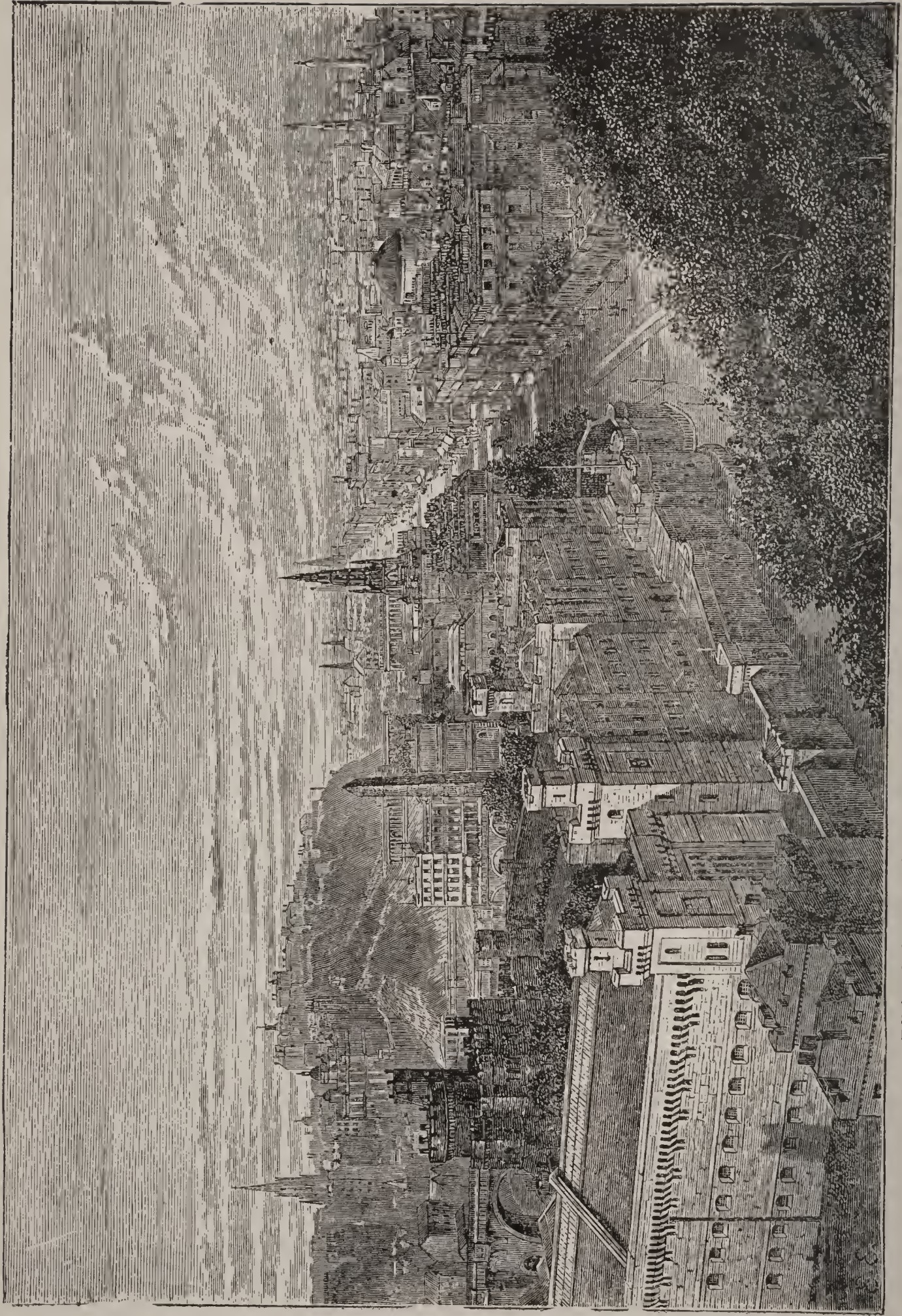

Edinburgh, from the Calton Hill, showing the Prison, the Castle, Scott Monument, Princes Street, &c.

EDINBURGH.

tained by broad stone stairs, winding from the lowest part of the building to the top. In the Old Town the most remarkable public building is the castle. This fortress contains accommodation for 2000 soldiers, and the armoury space for 30,000 stand of arms. In an apartment here is kept the ancient regalia of Scotland. The palace of Holyrood, or Holyrood House, as it is more generally called, stands, as already mentioned, at the lower or eastern extremity of the street leading to the castle. No part of the present palace is older than the time of James V. (1528), while the greater portion of it dates only from the time of Charles II. In the north-west angle of the building are the apartments which were occupied by Queen Mary, nearly in the same state in which they were left by that unfortunate princess. Adjoining the palace are the ruins of the chapel belonging to the Abbey of Holyrood, founded in 1128

by David I. The Advocates' Library, the largest library in Scotland, contains upwards of 250,000 printed volumes and 2000 MSS. It is one of the libraries entitled to a copy of every copyright book published in Great Britain. On the south side of the Old Town, and separated from it also by a hollow crossed by two bridges (the South Bridge and George IV. Bridge), stands the remaining portion of the city, which, with the exception of a few unimportant streets, is mostly modern. Besides the buildings already noticed Edinburgh possesses a large number of important edifices and institutions, chief amongst which are the Royal Institution (containing accommodation for various bodies), the National Gallery of Scotland, the Museum of Science and Art, the new Episcopal Cathed-

ral of St. Mary's, &c. Amongst the more prominent educational institutions are the University (see below), the High-school, the Academy, the New or Free Church Theological College, the United Presbyterian Theological Hall, the Edinburgh School of Medicine, the Veterinary College, the Fettes College, an institution resembling the great English public schools, the Heriot-Watt Col-

lege of Science and Literature. In 1887 the citizens decided to establish a public library. The manufactures of Edinburgh are neither extensive nor important. Printing, book-binding, coach-building, type-founding, machine-making, furniture-making, ale-brewing, and distilling are the principal industries. Edinburgh is the headquarters of the book trade in Scotland, and the seat of the chief government departments. The origin of Edinburgh is uncertain. Its name is thought to be derived from Eadwinsburh, the



Edinburgh—Victoria Hall and part of Castle-hill.

Burgh of Edwin, a powerful Northumbrian king, who absorbed the Lothians in his rule. The town was made a royal burgh in the time of David I.; but it was not till the 15th century that it became the recognized capital of Scotland. Pop. in 1891, 261,261. The county of EDINBURGH or MID-LOTHIAN is bounded N. by the Firth of Forth, along which it extends 11 or 12 miles; and by the counties of Linlithgow, Haddington, Berwick, Lanark, Peebles, Selkirk, and Roxburgh; area, 234,926 acres, over half of which is arable or under permanent pasture. The s.s.e. and s.w. parts of the county are diversified with hills, of which the two principal ranges are the Pentlands and Moorfoots, the former stretching across the county to within 4 miles of Edinburgh. The prin-

cipal rivers are the North and South Esks and the Water of Leith, all running into the Forth. The Lowlands towards the Forth are the most fertile; the farms are of considerable size, and the most approved methods of agriculture in use. The hilly parts are chiefly under pasturage and dairy farming. The chief crops are oats, barley, turnips, and potatoes. The manufactures of the county are comparatively limited, but include ale, whisky, gunpowder, paper, tiles, &c. The fisheries on the Forth are valuable. The chief towns are: Edinburgh, capital of Scotland, Leith, Dalkeith, Musselburgh, and Portobello. The county returns one member to the House of Commons. Pop. 1891, 444,055.

Edinburgh, DUKE OF, H.R.H., Prince Alfred Ernest Albert, K.G., K.P., Duke of Saxony and Prince of Saxe-Coburg-Gotha, the second son of Queen Victoria, was born at Windsor Castle Aug. 6, 1844. He was educated by special tutors, and at the age of fourteen joined the steam-frigate *Euryalus* as naval cadet, and served on various foreign stations. In 1862 he declined the offer of the throne of Greece. On his majority he received £15,000 a year by vote from parliament, and was created Duke of Edinburgh, Earl of Kent, and Earl of Ulster. In 1867 the duke was appointed to the command of the frigate *Galatea*, in which he visited Australia, Japan, China, India, and other countries. In Australia he narrowly escaped assassination by an Irishman named O'Farrell. In 1874, Jan. 23, he married the Grand-duchess Marie, only daughter of the Emperor of Russia. In August, 1893, became reigning Duke of Saxe-Coburg-Gotha. He has one son and four daughters.

Edinburgh Review, THE, a quarterly review established in 1802. It had an immediate and striking success, the brilliancy and vigour of its articles being much above the periodical literature of that time. In politics it was Whig, and did good service in developing and strengthening the opinions of its party. The Review was founded by a knot of young men living in Edinburgh, the more prominent of whom were Brougham, Jeffrey, Sydney Smith, and F. Horner. It was edited for a few numbers by Sydney Smith, and afterwards from 1803 to 1829 by Jeffrey, under whose editorship it reached the summit of its prosperity.

Edinburgh University, the latest of the Scottish universities, was founded in 1582

by a charter granted by James VI. Originally there were only four regents (or professors), besides a principal, but the number of chairs is now about forty, besides assistants. The government, as in the other Scottish universities, is vested in the Senatus Academicus, the university court, and the general council. The chancellor of the university is elected for life by the general council. He is the head of the university and the president of the general council. The rector is elected for a term of three years by the matriculated students. He presides over the university court. The principal is the resident head of the college and president of the Senatus Academicus, which consists of him and the professors. The office is held for life. The university court consists of the rector, principal, the Lord-provost of Edinburgh, and assessors appointed by the chancellor, town-council of Edinburgh, the rector, the general council, and the senatus respectively. The general council consists of the chancellor, the members of the university court, the professors, and all graduates of the university. There are four faculties, viz. arts, divinity, law, and medicine. Some of the professors are appointed by the crown, others are elected by the university court and by special electors, and a considerable number by the curators, who also elect the principal. The number of matriculated students has recently been about 3500 each winter, the greater number in medicine. The course in arts extends over four winter sessions, lasting from the end of October till the second Friday in April, but by passing a special examination before entering on their course students may obtain a degree in Arts after a course of three years. The degree of M.A. is conferred on all who have completed their course and passed the ordinary examinations in the classical department (Latin and Greek), the department of mathematics and natural philosophy, and that of logic and metaphysics, moral philosophy, and rhetoric and English literature. Three medical degrees are conferred: Bachelor of Medicine (M.B.), Master in Surgery (C.M.), and Doctor of Medicine (M.D.). The curriculum which a candidate for the first two degrees must pass through extends over four years of two sessions each. For the degree of M.D. two years' practice in addition is required. The degrees in law are Bachelor of Laws (LL.B.), Bachelor of the Law (B.L.), and Doctor of Laws (LL.D.). The last is purely honorary. The degrees of

Bachelor of Divinity (B.D.) and Doctor of Divinity (D.D.), the latter honorary, are bestowed in the faculty of divinity. The theological curriculum extends over three full and regular sessions or two full and two partial sessions. Degrees in science are also conferred. The degree of D.Sc. is conferred in the physical, in the natural, and in the mathematical sciences, in engineering, in public health or sanitary science, in mental science, and in philology. That of B.Sc. is conferred only in mathematical, physical, and natural science, in engineering, and in public health. The present university buildings were begun in 1789. The library of the university contains about 170,000 printed volumes, besides 2000 manuscripts. There is also a separate theological library containing about 10,000 volumes. There are various bursaries, scholarships, and fellowships, amounting annually to about £10,000. The University of Edinburgh unites with that of St. Andrews in returning one member to parliament. The constituency consists of the general council.

Ed'ison, THOMAS ALVA, an American inventor, born in Ohio in 1847, of a mother of Scotch and a father of Dutch extraction. He was poorly educated, but in some measure supplied the defect by assiduous reading. He became a news-boy on the Grand Trunk Railway, and afterwards becoming possessed of some type, issued a small sheet of his own on the train. He then set himself to learn telegraph work, and in a short time became an expert operator. In 1863, while at Indianapolis, he invented an automatic telegraph repeater. This was the first of a long series of improvements and inventions. He opened an extensive establishment at Newark for the manufacture of electrical, printing, automatic, and other apparatus. In 1876, his health breaking down, he gave up manufacturing and removed to Menlo Park, near New York, where he devoted himself to investigation. Amongst his numerous inventions are the quadruplex telegraph, the carbon telephone, the 'Edison system' of lighting, the electric fire-alarm, and the 'Edison electric railway,' the phonograph, and the photometer.

Edition, the number of copies of a book printed at one impression, or the aggregate copies of a literary work regarded as bearing a special character, either when first published or subsequently. The first printed edition of some ancient classic or work long in MS. is usually called the *editio princeps*.

Ed'monton, a town in England, county of Middlesex, $7\frac{1}{2}$ miles north of London, with an extensive trade in timber, carried on by the Lea River navigation. The 'Bell at Edmonton' has become famous by association with the adventures of Cowper's John Gilpin. Pop. 1891, 25,380.

Ed'mund, St., King of the East Angles, began to reign in 855, died in 870. He was revered by his subjects for his justice and piety. In 870 his kingdom was invaded, and he himself slain, by the Danes. The church made him a martyr, and a town (Bury St. Edmunds) grew up round the place of his sepulture.

Edmund I., King of England, an able and spirited prince, succeeded his brother Athelstan in 940. He conquered Cumbria, which he bestowed on Malcolm, king of Scotland, on condition of doing homage for it to himself. He was slain at a banquet May 26, 946.

Edmund II., surnamed *Ironsides*, King of England, was the eldest son of Ethelred II., and was born in 989. He was chosen king in 1016, Canute having been already elected king by another party. He won several victories over Canute, but was defeated at Assandun in Essex, and forced to surrender the midland and northern counties to Canute. He died after a reign of only seven months.

Edom, in the New Testament *Idumæa*, in ancient times a country lying to the south of Palestine. The Edomites are said in Genesis to be the descendants of Esau, who was also called Edom (a word signifying 'red'), and who dwelt in Mount Seir, the mountain range now called *Jebel Shera*, stretching between the Dead Sea and the Gulf of Akabah. The Edomites were subdued by King David, and after the separation of the ten tribes remained subject to the Kingdom of Judah until the reign of Jehoram, when they revolted and secured their independence for a time. They were again subdued about half a century later by Amaziah, and again, in the reign of Ahaz, recovered their independence, which they maintained till the time of the invasion of Judea by Nebuchadnezzar. They fell under the rule of the Persians, and latterly their fortunes were merged in those of Arabia. The chief city in this region was Petra, which now presents remarkable ruins, rock-cut temples, &c.

Edred, King of England, son of Edward the Elder, succeeded to the throne on the murder of his brother, Edmund I., in May,

946. He quelled a rebellion of the Northumbrian Danes, and died in 955.

Edriophthalmata, one of the great divisions of the Crustacea, including all those genera which have their eyes sessile, or imbedded in the head, and not fixed on a

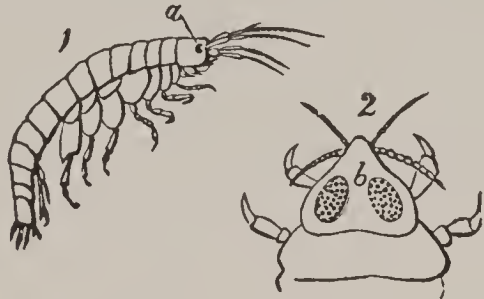

Edriophthalmata.

1, Fresh-water shrimp (*Gammarus pulex*): a, single eye.
2, Head of *Cymothoa*. b, Clusters of simple eyes.

peduncle or stalk as in the crabs, lobsters, &c. It is divided into three orders, viz. *Læmodipoda*, *Amphipoda*, *Isopoda*, and includes slaters, sandhoppers, woodlice, &c. Some are parasitic on fishes, and of the others some live in the sea and some on land, as the common and the sea woodlouse.

Edri'si, ABU-ABDALLAH MOHAMMED, a famous Arabian geographer, a descendant of the ancient princely family of the Edrisites, born about 1100 A.D., died about 1180. He studied at the Moorish University of Cordova, after which he travelled through various countries. At the request of King Roger II. of Sicily he constructed a globe with a map of the earth, which represented all the geographical knowledge of the age. He accompanied this with a descriptive treatise completed about 1150, and still extant.

Education (ultimately from *L. e*, out, and *duco*, to draw), in the widest sense, all that course of instruction and discipline which is intended to enlighten the understanding, correct the temper, cultivate the taste, and form the manners and habits of youth, and fit them for usefulness in their future stations. Or it may be defined as the art or scientifically-matured system of developing and cultivating the various physical, intellectual, æsthetic, and moral faculties; and may thence be divided into four branches—physical, intellectual, æsthetic, and moral education. Under physical education is included all that relates to the healthy development of the organs of sensation and the muscular and nervous system. Intellectual education comprehends the means by which the powers of the understanding

are to be developed and improved, and the imparting of instruction in the various branches of knowledge. *Æsthetic* education comprehends the agencies which purify and refine the mind by training it to perceive and take delight in what is beautiful, true, and pure in nature, literature, and art. Moral education (in which may or may not be included religious education) embraces the various methods of cultivating and regulating the affections of the heart. In the popular view education is much the same as instruction, and is regarded as consisting simply in the lessons and discipline learned in connection with attendance at school. So far as governments or other public bodies have interested themselves in the education of youth this view is tolerably correct; but probably the most perfect system of education would be one in which schools formed no part whatever. Schools, however, seem to have been established at a very early period in the history of all civilized communities, though not necessarily in connection with any system of national education. Indeed a thoroughly-organized system of national education exists in but few states, Germany being the most conspicuous example of such. In England no national system existed till the passing of the Education Act of 1870, and in Britain it is only elementary education that can be said to be established on a satisfactory footing. (See *Britain*, and articles on other countries.) A complete system of national education ought to make satisfactory provision for primary or elementary education, secondary education, and higher or university education, besides providing for the due education of teachers, and for technical education, commercial education, artistic education, &c.; but how far education in any department should be free (or at the expense of the state) is a question on which authorities are not agreed. Elementary education is generally speaking free in France, Italy, Germany, the United States, Canada, several of the Australian colonies, and elsewhere. In a properly-organized system the three great classes of educational institutions would be interdependent, the primary schools supplying pupils satisfactorily equipped for passing into the secondary schools, and these again passing on a certain number of their pupils to the university sufficiently equipped for entering on their more advanced studies. It is generally agreed that elementary education should

be compulsory, and this is now the law in Britain, Germany, France, Italy, Denmark, many of the United States, &c.; but the law may exist with more or less laxity in the enforcement of it. The elementary schools have, as their special province, the teaching of those branches of education that everyone ought to be instructed in, such as reading, writing, arithmetic, grammar, geography, &c.; but they usually teach also a number of other subjects. The secondary schools include institutions known as high schools, academies, grammar-schools, colleges, &c. The subjects taught in them are such as ancient and modern languages, mathematics, science, history, geography, &c., and they may either prepare pupils who intend to engage in commerce or other business, or who intend to proceed to the university. Thus in some secondary schools there is a *modern side* and a *classical side* (or similar divisions); while in Germany there are the two distinct classes of schools, the 'real-schools' (for modern subjects), and the *gymnasia*. The universities provide an education for the so-called 'learned professions,' as well as for all who appreciate the advantages of a university training. Their most characteristic feature is the privilege of granting university degrees. In various countries (including some of the British colonies) the public education is under the care of a special minister. In Britain it is under a special committee of the privy-council, having at its head the president of the council, and next to him a vice-president, who has the position of a responsible minister for education.

Edward, known as *the Elder*, King of England, son of Alfred the Great, born about 870, succeeded his father in 901. His reign was distinguished by successes over the Danes. He fortified many inland towns, acquired dominion over Northumbria and East Anglia, and subdued several of the Welsh tribes. He died in 925.

Edward, surnamed the *Martyr*, King of England, succeeded his father, Edgar, at the age of fifteen, in 975. His reign of four years was chiefly distinguished by ecclesiastical disputes. He was treacherously slain in 979 by a servant of his step-mother, at her residence, Corfe Castle. The pity caused by his innocence and misfortune induced the people to regard him as a martyr.

Edward, King of England, surnamed the *Confessor*, younger son of Ethelred II. On

the death of his maternal brother, Hardicanute the Dane, in 1041, he was called to the throne, and thus renewed the Saxon line. Edward was a weak and superstitious, but well-intentioned prince, who acquired the love of his subjects by his monkish sanctity and care in the administration of justice. His queen was the daughter of Godwin, earl of Kent. He died in 1066, and was succeeded by Harold, the son of Godwin. He caused a body of laws to be compiled from those of Ethelbert, Ina, and Alfred, to which the nation was long fondly attached. He was canonized by Pope Alexander III. in 1166.

Edward, Prince of Wales, surnamed the *Black Prince*, born June 15, 1330, the eldest son of Edward III. and Philippa of Hainault. In 1346 he commanded part of



Edward the Black Prince—Effigy at Canterbury.

the forces at the battle of Crécy, and earned the praise of his warlike father. It was on this occasion that he adopted the motto *Ich dien* (I serve), used by all succeeding princes of Wales. In 1355 he commanded the army which invaded France from Gascony, and distinguished himself the following year at the great battle of Poitiers. By the Peace of Brétigny the provinces of Poitou, Saintonge, Périgord, Limousin were annexed to Guienne and formed into a sovereignty for the prince under the title of the Principality of Aquitaine. A campaign in Castile, on behalf of Pedro the Cruel, and the heavy taxes laid on Aquitaine to meet the expenses, caused a rebellion, and ultimately involved him in a war with the French king. His own health did not allow him to take the field, and having seen his generals defeated he

withdrew into England, and after lingering some time died (1376), leaving an only son, afterwards Richard II.

Edward I. (of the Norman line), King of England, son of Henry III., was born at Winchester in 1239. The contests between his father and the barons called him early into active life, and he finally quelled all resistance to the royal authority by the decisive defeat of Leicester at the battle of Evesham, in 1265. He then proceeded to Palestine, where he showed signal proofs of valour, although, owing to the death of the French king, no conquest of any importance was achieved. On his return home he showed great vigour as well as a degree of severity in his administration. He commenced a war with Llewellyn, Prince of Wales, which ended in the annexation of that principality to the English crown in 1283. His next attempt was on the independence of Scotland. John Baliol, having been induced to do homage for his crown to Edward, was forced by the indignation of the Scottish people into war with England. Edward entered Scotland in 1296, devastated it with fire and sword, and placed the administration of the country in the hands of officers of his own. But next summer a new rising took place under the celebrated William Wallace. Wallace's successes recalled Edward to Scotland with an army of 100,000 men. Wallace was at length betrayed into his hands and executed as a traitor. But Edward's efforts to reduce the country to obedience were unavailing, and with the flight of Robert Bruce, earl of Carrick, to Scotland, the banner of Scottish independence was again unfurled. Edward assembled another army and marched against Bruce, but only lived to reach Burgh-on-Sands, a village near Carlisle, where he died 7th July, 1307. Edward I. was wise in council and vigorous in action. During his reign great progress was made in the establishment of law and order throughout the land.

Edward II., King of England, born at Caernarvon Castle in 1284, and the first English Prince of Wales, succeeded his father, Edward I., in 1307. He was of an agreeable figure and mild disposition, but indolent and fond of pleasure. After marching as far as Cumnock, in Ayrshire, with the army collected by his father, he returned, dismissed his troops, and abandoned himself entirely to amusements. His weakness for a clever but dissolute young Gas-

con, Piers Gaveston, on whom he heaped honours without limit, roused the nobles to rebellion. Gaveston was captured and executed as a public enemy. Two years after, in 1314, Edward assembled an immense army to check the progress of Robert Bruce, but was completely defeated at Bannockburn. In 1322 he made another expedition against Scotland, but without achieving anything important. The king's fondness for another favourite, Hugh le Despenser, had made a number of malcontents, and Queen Isabella, making a visit to France, entered into a correspondence with the exiles there, and formed an association of all hostile to the king. Aided with a force from the Count of Hainault she landed in Suffolk in 1326. Her army was completely successful. The Despensers were captured and executed, and the king was taken prisoner and confined in Kenilworth, and ultimately in Berkeley Castle, where Mortimer, the paramour of the queen, sent two ruffians, who murdered the unhappy monarch, 21st Sept. 1327.

Edward III., King of England, son of Edward II. by Isabella of France, was born in 1313. On his father's deposition in 1327 he was proclaimed king under council of regency, while his mother's paramour, Mortimer, really possessed the principal power in the state. The pride and oppression of Mortimer now became so intolerable that a general confederacy was formed against him. The result was the seizure of Mortimer (10th Oct. 1330), and his execution. Edward now turned his attention to Scotland, and having levied a well-appointed army, defeated the regent, Douglas, at Halidon Hill, in July 1333. This victory produced the restoration of Edward Baliol, who was, however, again expelled, and again restored, until the ambition of the English king was diverted by the prospect of suc-



Edward III.—From the Effigy on his tomb in Westminster Abbey.

ceeding to the throne of France. Other claims were superior, but Edward, collecting an army and accompanied by the Black Prince, crossed over to France. The memorable battle of Crécy followed, August 25, 1346, which was succeeded by the siege of Calais. In the meantime David II., having recovered the throne of Scotland, invaded England with a large army, but was defeated and taken prisoner by a much inferior force under Lord Percy. In 1348 a truce was concluded with France; but on the death of King Philip, in 1350, Edward again invaded France, plundering and devastating. Recalled home by a Scottish inroad he retaliated by carrying fire and sword from Berwick to Edinburgh. In the meantime the Black Prince had penetrated from Guienne to the heart of France fought the famous battle of Poitiers, and taken King John prisoner. A truce was then made, at the expiration of which (1359) Edward again crossed over to France and laid waste the provinces of Picardy and Champagne, but at length consented to a peace. This confirmed him in the possession of several provinces and districts of France which were intrusted to the Prince of Wales (the Black Prince), but gradually all the English possessions in France, with the exception of Bordeaux, Bayonne, and Calais, were lost. King Edward died a year after his heroic son, June 21, 1377.

Edward IV., King of England, was born in 1441. His father, Richard, duke of York, was grandson of Edward, earl of Cambridge and duke of York, fourth son of Edward III., while the rival line of Lancaster descended from John of Gaunt, the third son. The York line had intermarried with the female descendants of Lionel, the second son, which gave it the preferable right to the crown. Edward, on the defeat and death of his father at the battle of Wakefield, assumed his title, and having entered London after his splendid victory over the troops of Henry VI. and Queen Margaret at Mortimer's Cross, in Feb. 1461, was declared king by acclamation. The victory of Towton, soon after his accession, confirmed his title, and three years after, on May 4, 1464, the battle of Hexham completely overthrew the party of Henry VI. The king now made an imprudent marriage with Elizabeth, widow of Sir John Grey, at the very time when he had despatched the Earl of Warwick to negotiate a marriage for him with the sister of the French

king. He thus alienated powerful friends, and Warwick, passing over to the Lancastrian cause, gathered a large army, and compelled Edward to flee the country. Henry's title was once more recognized by parliament. But in 1471 Edward, at the head of a small force given him by the Duke of Burgundy, landed at Ravenspur in Yorkshire, and his army, being quickly



Edward IV.

increased by partisans, marched swiftly on London and took the unfortunate Henry prisoner. Warwick now advanced with an army to Barnet, where a battle was fought, 4th April, 1471, which ended in the death of Warwick, and a decisive victory on the part of Edward. Shortly afterwards Edward also met and defeated a Lancastrian army, headed by Queen Margaret and her son Edward, at Tewkesbury. The prince was murdered the day after the battle, and the queen was thrown into the Tower, where her husband Henry soon after died. Edward was preparing for another expedition against France when he was taken off by sickness in April, 1483, in the forty-second year of his age, and twenty-third of his reign.

Edward V., King of England, the eldest son of Edward IV., was in his thirteenth year when he succeeded his father in 1483. He fell into the hands of his uncle, the Duke of Gloucester, who made himself king as Richard III., and caused the young king and his brother to be sent to the Tower, where, it is said, he had them smothered by ruffians.

Edward VI., King of England, son of Henry VIII., by Jane Seymour, was born

in 1537. At his father's death he was only ten years of age. His education was intrusted to men of the first character for learning, under whose training he made great progress and grew up with a rooted zeal for the doctrines of the Reformation. His reign was, on the whole, tumultuous and unsettled. In October 1551 the Protector Somerset, who had hitherto governed the kingdom with energy and ability, was deposed by the intrigues of Dudley, duke of Northumberland, who became all-powerful and induced the dying Edward to set aside the succession of his sisters, Mary and Elizabeth, and settle the crown upon Lady Jane Grey, to whom he had married his son Lord Guildford Dudley. Edward died of a pulmonary complaint in July 1553.

Edward, THOMAS, a Scottish naturalist, born 1814, died 1886. The son of poor parents, he was apprenticed to a shoemaker and continued to work as such till nearly the end of his life, having on his scant earnings to support a wife and eleven children. Under such hard conditions of life he succeeded, by indomitable perseverance, in acquiring much knowledge of natural history and some fame as a naturalist. A biography of Edward, written by Mr. Smiles, appeared in 1876 (*Life of a Scotch Naturalist*), and being thus brought prominently before the public, a pension of £50 a year was shortly afterwards conferred on him by the Queen.

Edwardesábád, town and cantonment in Hindustan, head-quarters of Bannu district, Punjab, founded in 1848 by Major Edwardes. Pop. 8960.

Edwards, AMELIA BLANDFORD, an English novelist, born in 1831. As far back as 1853 she began to contribute to periodicals. Among her best-known novels are *Hand and Glove* (1859); *Half a Million of Money* (1865); *Lord Brackenbury* (1880). Besides novels Miss Edwards had written ballads and books of travel, and latterly devoted herself to Egyptology. Died April 16, 1892.

Edwards, BRYAN, English writer, born in Wiltshire in 1743. He inherited a large fortune from an uncle in Jamaica, where he long resided. His *History, Civil and Commercial, of the British Colonies in the West Indies* appeared in 1793. He died in 1800.

Edwards, JONATHAN, a celebrated American theologian and metaphysician, born at East Windsor, Connecticut, October 5, 1703. He entered Yale College in 1716, and studied till 1720; in 1722 received a license

as preacher. In 1723 he was elected a tutor in Yale College, but resigned in 1726 to be ordained as minister at Northampton (Mass.). After more than twenty-three years of zealous service here he was dismissed by the congregation owing to the severity with which he sought to exercise church discipline. He then went as a missionary among the Indians at Stockbridge, in Massachusetts. Here he composed his famous work on the *Freedom of the Will*, a masterpiece of metaphysical argument. It appeared in 1754, and was completed within four months and a half. In 1758 he was chosen president of the college at Princeton, New Jersey, but died shortly afterwards, March 22, 1758.

Edwy, King of England, son of Edmund I., succeeded his uncle Edred in 955. Taking part with the secular clergy against the monks, he incurred the confirmed enmity of the latter. The papal party, headed by Dunstan, was strong enough to excite a rebellion, by which Edwy was driven from the throne to make way for his brother Edgar. He died in 959, being probably not more than eighteen or nineteen years old.

Eecloo (āk-lō'), a town, Belgium, province of East Flanders, 11 miles north-west from Ghent, the seat of various manufactures. Pop. 10,400.

Eel, the general name of a family of teleostean fishes belonging to the apodal section of the Malacopterygii. They belong to various genera. The genus *Anguilla* is characterized by its serpent-like elongated body, by the absence of ventral fins, and the continuity of the dorsal and anal fins round the extremity of the tail. The dorsal fin commences half-way between the head and the anal fin, and the lower jaw projects beyond the upper. In the genus *Conger*, which is exclusively marine, the dorsal fin commences above the pectoral, and the upper jaw is the longer. The smoothness of the body—the scales being inconspicuous—and the serpentine movements of eels are proverbial. The conger and at least three other species—the sharp-nosed (*Anguilla acutirostris* or *A. vulgāris*), the broad-nosed (*A. latirostris*), and the snig (*A. mediorostris*) belong to Britain. The species of the genus *Anguilla*, which are both fresh-water and marine, seldom exceed 30 inches in length. In England river eels are caught in great numbers by means of eel-bucks or eelpots, traps consisting of a kind of basket

with a funnel-shaped entrance composed of willow rods converging towards a point, so that the eels can easily force their way in but cannot return. A stocking or tube of coarse cloth hanging from an aperture of a box down into the interior is also used. In England a kind of trident is used also for taking them, called an *eel-spear*. A fisherman wades to the shallows, and, striking his spear in the mud in every direction around him, the eels reposing on the bottom are caught between the prongs. They are also taken by hooks and lines and in other ways. Eels avoid cold, and frequently migrate in winter to the mud or brackish water of estuaries where the temperature is higher. They have even been met with in large numbers performing migrations on land, mostly intervening necks of soil covered with damp grass. Some eels spawn in the estuaries of rivers, and immense numbers of the young eels pass up the streams in spring, their passage in England being called the *eel-fare*. Eels are considered excellent food in England and elsewhere, and large numbers are imported from Holland into London, but they are hardly eaten in Scotland. See *Conger-eel*, *Electric Eel*, *Muræna*.

Eel-pout. See *Burbot*.

Effen'di, a Turkish title which signifies lord or master. It is particularly applied to the civil, as *aga* is to the military officers of the sultan. Thus the sultan's first physician is called *Hakim effendi*, the priest in the seraglio *Iman effendi*, &c.

Efferves'cence, the rapid escape of a gas from a liquid, producing a turbulent motion in it, and causing it to boil up. It is produced by the actual formation of a gas in the liquid, as in fermentation, or by the liberation of a gas which has been forced into it, as in aerated beverages.

Ef'figy, an image or portrait, most frequently applied to the figures on sepulchral monuments.—*To burn or hang in effigy*, is to burn or hang an image or picture of a person, a mode in which the populace sometimes expresses its feelings respecting an obnoxious personage.

Efflores'cence, the fine white, feathery crystallization of sulphate and carbonate of sodium which appears on walls, or similar crystallizations on the surface of the earth, in decomposing rocks, &c. In medicine the term is applied to an eruption or rash, as in measles, &c.

Effluvium (pl. EFFLUVIA), a noxious or disagreeable exhalation.

Effodien'tia (digging animals), a term applied sometimes to the division of the Edentates which comprises the insect-eating forms, as the hairy ant-eater of South America, the armadillo, &c.

Eft. See *Newt*.

Égalité, PHILIPPE. See *Orleans, Louis Philippe Joseph*.

Egbert, considered the first king of all England, was of the royal family of Wessex. He succeeded Brihtric in 802 as King of Wessex. He reduced the other kingdoms and rendered them dependent on him in 829, thus becoming their overlord. He died in 839.

Egede, HANS (ā'ge-dā), the apostle of Greenland, was born in 1686 in Norway. In 1721 Egede set sail for Greenland with the intention of converting the natives to Christianity, and for fifteen years performed the most arduous duties as missionary, winning by his persevering kindness the confidence of the natives. In 1736 he returned to Copenhagen, where he was made a bishop and director of the Greenland Missions. He died in 1758. His son, PAUL EGEDE, born 1708, followed in his father's footsteps, became Bishop of Greenland, and died in 1789.

Eger (ā'gèr), a town of Bohemia, on a rocky eminence above the Eger, 91 miles west of Prague; once an important fortress, though now quite dismantled. It has manufactures of woollens, cottons, leather, soap, &c. Wallenstein was assassinated here (1634). Pop. 13,463. For another Eger see *Erlou*.

Ege'ria, a nymph who received divine honours among the Romans. Numa is said to have received from her the laws which he gave to the Romans.

Egerton, FRANCIS. See *Bridgewater, Duke of*.

Egg, a body specially developed in the females of animals, and in which, by impregnation, the development of the young animal takes place. Birds, reptiles, fishes, insects, and worms are oviparous, *i.e.* bring forth eggs or ova, as do also, amongst mammalia, the ornithorhynchus and echidna. The egg contains the germ of the young animal, as well as the substance which serves for its nourishment. All it needs for its development is external heat. (See *Incubation*.) The eggs of animals lower than the birds have usually only three parts, *viz.* the germinal spot or dot, the germinal vesicle, and the vitellus or yolk; the first being

contained in the vesicle, and that again in the yolk. Besides these parts the eggs of birds have the white or albumen, and the shell, which consists of a membrane coated with carbonate of lime. The eggs of birds, especially of fowls, are a pleasant and nutritive food. The common domestic fowl, the turkey, the pea-hen, and the common duck produce the eggs which are commonest in the market. Among reptiles, turtle produce eggs which are good for eating. The eggs of fishes are their roe or spawn. A hen's egg of good size weighs about 1000 grains, of which the white constitutes 600, the yolk 300, and the shell 100. When the white of an egg is warmed it coagulates to a firm opaque mass. Eggs form an important article in British commerce, being imported latterly to the value of over £3,000,000 annually, mainly from France, Belgium, Germany, and Denmark.

Egg, an island of Scotland. See *Eigg*.

Egga, a town of West Africa, on the right bank of the Niger, about 70 miles above the junction of the Binue. Pop. 8000.

Eggar, or **EGGER**, a name given to moths of the family Bombycidæ. *Lasiocampa trifolii*, a well-known British moth, is called the grass-egger, and the *L. roboris* the oak-egger, from the food of their caterpillars.

Egg-bird, *Hydrochelidon fuliginosum*, a species of tern, a bird of considerable commercial importance in the West Indies, as its eggs, in common with those of two other species of tern, form an object of profitable adventure to the crews of numerous small vessels.

Egg-flip, a drink made of warmed beer, flavoured with a little sugar, spirit, spices, and eggs beaten with it.

Egg-nog, a drink consisting of the yolk of eggs beaten up with sugar, and the white of eggs whipped, with the addition of wine or spirits.

Egg-plant (*Solanum melongëna*), natural

order Solanaceæ, an herbaceous plant, from 1 foot to 18 inches high, with large white or purplish flowers. The fruit is about the size of a goose's egg, and generally yellow, white, or violet, and when boiled or stewed is used as an article of food. It is cultivated in India, the U. States, &c., and in European hothouses. There are several other species of egg-plants, as *S. indicum*, *S. sodomæum*, &c.

Egham, a village of England, co. of Surrey, on the Thames opposite Staines, about 21 miles from London, with the Royal Holloway College for women, and the Holloway Sanatorium. Near it is Runnymede, where King John signed Magna Charta.

Egil Skallagrim, an Icelandic bard or poet of the 10th century, who distinguished himself by his warlike exploits in predatory invasions of Scotland and Northumberland. Having fallen into the hands of a hostile Norwegian prince, he procured his freedom by the composition and recitation of a poem called Egil's Ransom, which is still extant.

Egina. See *Ægina*.

Eg'inhard, or **EINARD**, a Frankish writer, born about 771, studied at Aix-la-Chapelle, under Alcuin. His talents and learning gained him the confidence of Charlemagne, who made him his private secretary and chaplain, and gave him his daughter Emma in marriage. On the death of the emperor, Eginhard took the cowl and became first abbot of the monastery at Seligenstadt, in Darmstadt, where he died in 844. Eginhard is the oldest German historian, and has left us a life of Charlemagne (*Vita Caroli Magni*), and Annals of the Franks, from 741 to 829. His letters, still extant, are also an important contribution to the history of the age.

Eg'lantine, one of the names of the sweetbrier (*Rosa rubiginosa*), a kind of wild rose. The name has sometimes been erroneously used for other species of the rose and for the honeysuckle.

Eg'mont, **LAMORAL, COUNT**, was born in 1522, of an illustrious family of Holland. He entered the military service, accompanied Charles V. in his African expeditions, and distinguished himself under Philip II. in the battles of St. Quentin (1557) and Gravelines (1558). Philip having gone to Spain, Egmont soon became involved in the political and religious disputes which arose between the Netherlands and their Spanish rulers. He tried to adjust the difficulties between both parties, and in 1565 went to Spain to arrange matters with Philip. He



Egg-plant (*Solanum melongëna*).

was well received, sent back with honour, but quite deceived as to the king's real intentions. In 1567 the Duke of Alva was sent with an army to the Netherlands to reduce the insurgents. One of his first measures was to seize Count Egmont and Count Horn. After a trial before a tribunal instituted by Alva himself they were executed at Brussels 5th June, 1568. A well-known drama of Goethe's is founded on the story of Egmont.

E'goism, as a philosophical doctrine, the view that the elements of all knowledge and the reality of the things known are dependent on the personal existence of the knower. Hence the logical position of the egoist is to doubt the substantial reality of everything except his own existence.

Eg'ret, a name given to those species of white herons which have the feathers of the lower part of the back elongated and their webs disunited, reaching to the tail or beyond it at certain seasons of the year. Their forms are more graceful than those of common herons. The American egret (*Ardëa egretta*) is about 37 inches long to the end of the tail; plumage soft and blended; head not crested; wings moderate; the tail short, of twelve weak feathers. The European egret (*A. alba*) is about 40 inches long, of a pure white plumage; the bill is black or dark brown, yellow at the base and about the nostrils, and the legs are almost black. The little egret (*A. garzetta*) is about 22 inches long from bill to end of tail, the plumage is white.

Eg'ripo, a name of Chalcis (which see).

Egypt (ē'jipt; Greek, *Aiguptos*; Hebrew, *Misr* or *Misraim*; ancient Egyptian, *Chem* or *Chemi*, 'the black land'; Arabic, *Misr* or *Musr*), a country in the north-eastern part of Africa, governed by a ruler (the *khedive* or viceroy) who pays tribute to the sultan of Turkey, but is virtually independent. Egypt is bounded on the N. by the Mediterranean Sea, on the E. by Arabia and the Red Sea, and on the W. by the Libyan Desert. Its natural southern frontier may be placed about Assouan (about 500 miles south of the Mediterranean), near which cultivated land almost disappears and the country begins to assume the features of the Nubian Desert. Egyptian troops, however, still hold the country as far as the Second Cataract of the Nile at Wady Halfa (about 670 miles south of the Mediterranean), which is the limit of free navigation for larger vessels. The authority of the khedive

extended till recently over the countries on the Upper Nile up to a few degrees from the equator, including Kordofan, Darfur, Bar-el-Ghasal, &c.; but this territory, acquired by conquest and known by the general name of the Soudan, has been evacuated owing to the rebellion of the people against Egyptian authority. On the Red Sea littoral the furthest point south under the Egyptian flag is Suakin. (See *Soudan*.) A small strip of N.W. Arabia on the east of the Red Sea belongs to Egypt, as also the Sinaitic peninsula and the Isthmus of Suez. The area is about 394,000 square miles (only some 13,000 being inhabited), with a population of 6,817,265 according to the census of 1890. The capital and largest town is Cairo, the next largest and chief seaport is Alexandria.

The inhabited portion of Egypt is mainly confined to the valley of the Nile, which, where widest (at the Delta), does not exceed 80 miles, and narrows steadily as we ascend its stream till, at the southern frontier, it is only 2 miles wide. The Nile has no tides, but runs constantly towards the sea at the rate of 2½ to 3 miles an hour. After it enters Egypt it flows in a northward direction but with considerable bends till it reaches lat. 30° 15', a little beyond Cairo, where it divides into two main streams, the Rosetta and Damietta branches, which inclose that portion of land known as the Delta and formed by deposits of alluvial matter. Bordering on the Mediterranean are several salt lakes or lagoons, Menzaleh being the largest, through which is carried the Suez Canal, connecting the Mediterranean and the Red Sea; and also passing through other salt lakes; about 150 miles south of the Mediterranean is the lake Birket-el-Kurun, fed by the Nile. As very little rain falls in Egypt, the prosperity of the country entirely depends upon the Nile, and especially upon the yearly overflow of the river, which so fertilizes the soil with a brown slimy deposit that it produces two crops a year. Beyond the limits of the inundation and of irrigation there is no cultivation whatsoever. The Nile begins to rise in June, and continues to increase until September, overflowing the low lands along its course, the waters being conveyed by canals where natural channels fail. The Delta then looks like an immense marsh interspersed with islands, villages, towns, and plantations, just above the level of the water. After a few days the water begins to subside, and leaves the land again dry about the

EGYPT.

end of October. The seed is then sown, and artificial irrigation is maintained by water raised from the river, and distributed by means of channels throughout the fields. The appliances for raising water are simple and primitive; chiefly the *shadoof* worked by two men, and the *sakieh* driven by a donkey or an ox. (See *Shadoof*, *Sakieh*.) The land is soon covered with green crops, and the first harvest is in March.

At Cairo the valley of the Nile becomes well defined. It is bordered on the east by what are called the Arabian hills, and on the west by the Libyan ranges. Beyond the limits of the valley on the Libyan side are five oases at intervals—those of Khârgéh, Dâkhel, Farâfra, Sîwa, and Bahriyeh—islands of verdure and cultivation, in some of which artesian wells are numerous. The great oasis Wah-el-Khârgéh extends south for 100 miles. These oases are also dependent on the Nile like the rest of habitable Egypt, for the water to which they owe their existence is partly derived from the subterraneous percolation from that river. The territory to the east of the Nile is mainly a bare rocky region, mountainous towards the coast, maintaining a small nomadic population. The broad plains of the Delta and the comparatively narrow valley of the river higher up, make two natural divisions of Egypt, Upper and Lower. These were anciently regarded as separate kingdoms. The lower part of the valley, however, which includes the fertile tract adjoining lake Birket-el-Kurun, known as the Fayoum, differs so much from the higher part as to give rise to the division into Lower, Middle, and Upper Egypt. The country is now divided into governorates and mudiriehs.

The atmosphere in Egypt is extremely clear and dry, the temperature regular and exceedingly hot. The winter months are the most delightful part of the year; later, the ground becomes parched and dry, and in May the suffocating khamseen, or simoom, begins to blow from the desert plains. Rain is scanty except near the sea-shore; but at night the dews are heavy in lower Egypt, and the air cool and refreshing. Egypt is not remarkably healthy, as, in addition to visitations of plague and cholera, ophthalmia, diarrhœa, dysentery, and boils are very prevalent.

The rock formations of Egypt consist largely of nummulite limestone, especially at the Nile and in the Libyan Desert, and of granite, syenite, porphyry, and other

crystalline rocks in the Arabian Desert (between the Nile and Red Sea), with sandstone in the south. Over a great extent of Egypt the rocks are covered with shifting sands, and in the lands bordering on the Nile by the alluvium deposited during the inundations, and which consists of an argillaceous earth or loam, more or less mixed with sand. Among the useful minerals found in the country are granite, syenite, basalt, porphyry, limestone, alabaster, natron, bitumen, salt, and sulphur.

Now as formerly there is little timber, the principal trees, besides the date-palm and tamarisk, being the sycamore fig, and acacia or gum-arabic tree, which last does not attain to any size north of Wady Halfa. The papyrus plant, once so important, is now to be found only in one or two spots. Of it was manufactured a paper which was supplied to all the ancient world. Beside the lotus or water-lily of the Nile, Egypt has always been celebrated for its production of corn, barley, a great variety of the bean class, leeks, garlic, onions, flax, and for plants of the cucumber tribe. To the products of ancient times have been added the sugar-cane, cotton plant, indigo, and tobacco.

Egyptian oxen were celebrated in the ancient world. The camel was early introduced; horses and asses have always abounded; sheep and goats are numerous; the cat is universal as a domestic animal. Wild animals include the hyena, jackal, fox, lynx, genet, ichneumon, jerboa, wild goat, gazelle and one or two other antelopes, hare, &c. The crocodile formerly reached the Delta, but is now seldom seen below Assouan. Water-fowl are plentiful; so are vultures and other birds of prey. The sacred ibis is still found in the south, and the pelican in the northern lagoons. Among the countless insects are the sacred beetle, the locust, and mosquito.

In spite of the fact that at least two and sometimes three successive crops may be gathered in a year, agriculture in Egypt is still in a very low state; and the extreme poverty and generally wretched condition of the cultivators render improvement difficult. There are few trades which have attained a development of any importance. The tanning and pottery-making, however, deserve praise; coarse cotton cloths are made; silk is cultivated; and the sugar-cane is grown to a considerable extent. The commerce of Egypt is considerable, and has greatly increased since the construction of

EGYPT.

the Suez Canal and the railways. The railways have a length of about 1200 miles. The total value of exports in 1891 amounted to £13,878,628, that of imports to £9,201,390. About 50 or 60 per cent. of the commerce is with Britain. Accounts are kept in Egyptian pounds, each containing 100 piastres, and equivalent to \$5.12.

Of the inhabitants of Egypt those of the peasant class, or Fellahs as they are called,

appear to be descendants of the ancient Egyptians mixed with Arab blood. Having embraced Mohammedanism, they are often denominated Arabs, though regarded by the true Arab with contempt. The Copts are the descendants of the ancient Egyptians who embraced and still cling to the Christian religion. Though comparatively few in number, their education and useful talents enable them to hold a respectable position



Chandlers' Shops, Lower Egypt.

in society, as clerks, accountants, &c. With those aboriginal inhabitants are mingled, in various proportions, Turks, Arabs (chiefly Bedouins), Armenians, Berbers, negroes, and a considerable number of Europeans, especially Greeks and Levantines.

The government of Egypt is in the hands of the khedive or viceroy, who is assisted by a ministry formed on the model of those of Western Europe. The title and government are hereditary, but the khedive, as a Turkish vassal, has to pay an annual tribute to the sultan of \$3,500,000. For some years previous to 1882 two controllers-general, appointed respectively by France and Britain, had extensive powers of control in the administration of the country; but in that year the French having refused to lend assistance in putting down the rebellion of Arabi Pasha, a British army occupied Egypt, and the government has since been carried on under the supervision of Britain, various

reforms having been introduced. Egypt is much burdened with the public debt, which amounts to the sum of £106,372,160. The chief items of revenue are the land-tax, producing over £5,000,000 a year, indirect taxes, and railways. The budget of 1893 showed an estimated revenue of about £10,010,000, the expenditure being some £460,000 less.

History.—The Egyptians are the earliest people known to us as a nation. When Abraham entered the Delta from Canaan they had been long enjoying the advantages of a settled government. They had built cities, invented hieroglyphic signs, and improved them into syllabic writing, and almost into an alphabet. They had invented records, and wrote their kings' names and actions on the massive temples which they raised. The arrangement of Egyptian chronology is still a much-disputed point amongst scholars. A list of the kings of Egypt, ar-

EGYPT.

ranged in thirty dynasties, was given by the priest Manetho (about 250 B.C.), and this division is still used. His list, however, is in a very corrupt condition and his method is not strictly chronological. Hence in the various systems of chronology adopted by Egyptologists the dates assigned to Mena (or Menes) vary from 5702 to 2440 B.C. According to tradition Mena formed the old empire of Egypt and founded its capital Memphis. The IVth Dynasty is distinguished as the 'Pyramid Dynasty.' Three of its kings, Khufu, Khafra, and Menkaura (according to Herodotus, *Cheops*, *Chephren*, and *Mykerinos*), built the largest pyramids. The date assigned to these kings in the chronology of Lepsius is 2800–2700. About 2400 the government of the empire seems to have been transferred from Memphis to Thebes, and with the beginning of Dynasty XII. the Theban line was firmly established. The chief princes of this dynasty are Amenemhat I. (2380), who seems to have extended the power of Egypt over a part of Nubia; Usurtasan I., who made further conquests in this direction; and Amenemhat III. (2179), who constructed Lake Meri (Mœris), a large reservoir for regulating the water supply of the Nile. About 2100 Egypt was conquered by the Hyksos, or shepherd kings, who invaded Egypt from the east and established their capital at Tanis (Zoan). The Theban princes seem, however, to have preserved a state of semi-independence, and at last a revolt commenced which ended by the shepherd kings being completely driven out of Egypt by King Aahmes (Amāsis) of Thebes (about 1600), the first of the XVIIIth Dynasty. With Aahmes and the expulsion of the shepherd kings began the reigns of those great Theban kings who built the magnificent temples and palaces at Thebes. The kings of the other parts of Egypt sank to the rank of sovereign priests. Thutmes (or Thothmosis II.) added Memphis to his dominions by his marriage with Queen Nitocris. Under Thutmes III and his successors there were successful expeditions against the Syrians and the Ethiopians. Amenhotep III. set up his two gigantic statues in the plain of Thebes, one of which the Greeks called the musical statue of Memnon. The Ramessides form the XIXth Dynasty. They commence with Ramses I., who seems to have been of Lower Egyptian extraction. His grandson, the great Ramses II., or Sesostris, was successful against the

neighbouring Arabs, and covered Egypt with magnificent buildings. Ramses II. was probably the Pharaoh who oppressed the Hebrews, and the exodus may have occurred under his successor Meneptah or Merenptah. Under the later Ramessides the Egyptian empire began to decay. A new dynasty, XXI., came to the throne with King Hirhor. The seat of their power was Tanis in the Delta. During this period a great number of foreigners, Libyans as well as Asiatics, established themselves in Egypt. About 961 Sheshenk I., the Shishak of the Bible, of a Shemite family from Bubastis, established a new dynasty (XXII.). He attempted to restore Egyptian rule in the East, and conquered and plundered Jerusalem. After his death Egypt was torn by civil wars, and eventually the Ethiopians under Shabak (Sabako) conquered it (XXVth Dynasty). For a time it was subject alternately to Ethiopian and Assyrian princes, but in the 7th century the kings of Saïs once more restored its independence and prosperity to Egypt. Psamethik I. (Psammetichus) warred successfully in Syria and Palestine. King Nekho (610–594) defeated Josiah, king of Judah, but his further progress was checked by Nebuchadnezzar. His sailors circumnavigated Africa. Uahbra (the Greek Apries, the Hophrah of the Bible); and Aahmes II. (Greek Amāsis) followed. About 523 Cambyses, King of Persia, overran Egypt and made it a Persian province. During the reign of Cambyses the Egyptians suffered much oppression. After the Persian defeat at Marathon the Egyptians rose and recovered their independence for a short time, but were again subdued, and, in spite of two other revolts, Egypt remained a Persian province till Persia itself was conquered by Alexander the Great B.C. 332.

Egypt now became a Greek state, many Greeks having been already settled in the country, and the Egyptians were treated as an inferior race. Alexandria was founded as the new Greek capital. On Alexander's death his general, Ptolemy, took possession of the throne and became the first of a Greek dynasty that for three hundred years made Egypt one of the chief kingdoms of the world. The Ptolemies were magnificent patrons of letters and arts. Theocritus, Callimachus, Euclid the geometrician, the astronomers Eratosthenes and Aratus, &c., flourished under their rule. But while the Alexandrian Greeks managed to keep down the native Egyptians, they were themselves

EGYPT.

sinking under the Romans. Ptolemy Auletes went to Rome to ask help against his subjects, and the famous Cleopatra maintained her power only through her personal influence with Julius Cæsar and Mark Antony. On the defeat of Mark Antony by Augustus, B.C. 30, Egypt became a province of Rome. It was still a Greek state, and Alexandria was the chief seat of Greek learning and science. On the spread of Christianity the old Egyptian doctrines lost their sway. Now arose in Alexandria the Christian catechetical school, which produced Clemens and Origen. The sects of Gnostics united astrology and magic with religion. The school of Alexandrian Platonics produced Plotinus and Proclus. Monasteries were built all over Egypt; Christian monks took the place of the pagan hermits, and the Bible was translated into Coptic.

On the division of the great Roman Empire (A.D. 337), in the time of Theodosius, into the Western and Eastern Empires, Egypt became a province of the latter, and sank deeper and deeper in barbarism and weakness. It was conquered in 640 A.D. by the Saracens under Caliph Omar. As a province of the caliphs it was under the government of the celebrated Abbasides—Harun-al-Rashid and Al-Mamun—and that of the heroic Sultan Saladin. The last dynasty was, however, overthrown by the Mamelukes (1250); and the Mamelukes in their turn were conquered by the Turks (1516–17). The Mamelukes made repeated attempts to cast off the Turkish yoke, and had virtually done so by the end of last century, when the French conquered Egypt and held it till 1801, when they were driven out by the British under Abercromby and Hutchinson.

On the expulsion of the French a Turkish force under Mehemet Ali Bey took possession of the country. Mehemet Ali was made pasha, and being a man of great ability administered the country vigorously and greatly extended the Egyptian territories. At length he broke with the Porte, and after gaining a decisive victory over the Ottoman troops in Syria in 1839 he was acknowledged by the sultan as viceroy of Egypt, with the right of succession in his family. Mehemet Ali died in 1849, having survived his son Ibrahim, who died in 1848. He was succeeded by his grandson Abbas, who, dying in 1854, was succeeded by his uncle Said, son of Mehemet. Under his rule railways were opened, and the cutting

of the Suez Canal commenced. After Said's death Ismail Pasha, a grandson of Mehemet Ali, obtained the government in 1863. His administration was vigorous but exceedingly extravagant, and brought the finances of the country into disorder. In 1866 he obtained a firman from the sultan granting him the title of khedive. In 1879 he was forced to abdicate under pressure of the British and French governments, and was replaced by his son Tewfik. In 1882 the 'national party' under Arabi Pasha revolted and forced the khedive to flee. On July 11 a British fleet bombarded Alexandria and restored the khedive, and at Tel-el-Kebir Arabi's forces were totally crushed on 13th September. A rebellion in the Soudan under the leadership of Mohammed Ahmed, the so-called mahdi, now gave the government trouble. In 1883 the mahdi's forces annihilated an Egyptian force under Hicks Pasha in Kordofan. British troops were now despatched to Suakin and inflicted two severe defeats on the mahdi's followers there. But the British cabinet had resolved to abandon the Soudan; and General Gordon, already famous for his work in this district, was sent to effect the safe withdrawal of the garrisons (1884). By this time, however, the mahdi's forces were strong enough to shut the general up in Khartoum. For nearly a year he held the town, but perished (Jan. 1885) before the relief expedition under Sir Garnet Wolseley could reach him. Since then the Anglo-Egyptian troops have re-occupied it. Prince Abbas succeeded as khedive in 1892—the British still retaining control.

Ancient Civilization.—The civilization of the Egyptians had reached a high pitch from the earliest period to which we can trace their history. The masonry of the passages in the great pyramid has not been surpassed at any age. More than 2000 B.C. the Egyptians had duodecimal as well as decimal numbers; weights and measures adjusted to a pound of 1400 grains. In mechanical arts the carpenter, boat-builder, potter, leather-cutter, glass-blower, and others are frequently represented on their ancient monuments, and we see the blow-pipe, bellows, and siphons; the press, balance, lever; the saw, the adze, the chisel, the forceps, the syringe, harpoon, razors; we have also glazed pottery, the potter's wheel, and the kiln; and dated specimens of glass of the time of Thothmes III., 1445 B.C. Gold-beating, damascening, engraving, casting, inlaying, wire-drawing, and other

EGYPT.

processes, were practised. The processes of growing and preparing flax, as well as the looms employed, are all depicted. The social and domestic life of the ancient Egyptians is pictured for us on the walls of their temples and tombs. The rich spent much of their time in hospitality and entertainments, especially of a musical kind. In the country districts the superintendence of the agricultural works or the fisheries on their estates was varied by the sports and pleasures of a country life. The lower orders were poor and uneducated, scantily fed and clothed, and held in contempt by the higher classes. But there was no strict separation into caste; and although the priests formed a ruling bureaucracy, the highest posts were open to the successful scholar. Next to the priesthood in importance was the military class or order, who were all landholders and bound to serve in time of war. Below these were the husbandmen, who paid a small rent to the king. Egyptian custom seems to have allowed but one wife, who occupied an honourable and well-established position as the 'lady of the house.'

The two main principles on which the religion of Egypt was based appear to have been the existence of an omnipotent Being, whose various attributes being deified, formed a series of divinities; and the deification of the sun and moon. Each group of divinities formed a triad composed of a chief male deity, with a wife or sister and a son, as Osiris, Isis, and Horus, or Amun, Maut, and Khonso. Amongst the other gods of the Egyptian Pantheon are Ra, the sun, usually represented as a hawk-headed man. Mentu and Atmu are merely two phases of Ra, the rising and the setting sun. The worship of the bull Apis is connected with Osiris. Serapis is the defunct Apis, who has become Osiris. Seth or Set represents the power of evil. Ammon (Egyptian Amen), originally a local god, owed his im-

portance to the greatness of his city, Thebes. Thoth is the chief moon-god, and is generally represented as ibis-headed. Anubis, the jackal-headed, belonged to the family of Osiris, and presided over mummification. Besides these deities the Egyptians worshipped beasts, reptiles, and even vegetables, probably as symbols. The Egyptians believed in the transmigration of souls and in the existence of a future state, in which mankind would be rewarded or punished according to their actions while on earth.

Ancient Architecture and Sculptures.—The monuments we have left to us in Egypt are of two main periods—those built in the times of the Pharaohs or native kings, and those built during the rule of the Greeks and Romans (subsequently to 330 B.C.). The former period was by far the longer and more important, and to it belong the most characteristic examples of Egyptian architecture and sculpture, such as pyramids, vast temples, some of them cut in the

solid rock (as at Ipsambul), rock-cut tombs, gigantic monolithic obelisks, and colossal statues. The characteristic features of the style are solidity, boldness, and originality. Among its peculiar characteristics may be

noted—symmetry of structure; the gradual converging of the walls of some of its edifices, especially of the propylæa or tower gateways of its temples; roofs and covered ways being flat, and composed of immense blocks of stone reaching from one wall or column to another, the arch not being employed nor yet timber; columns numerous, close, and massive, generally without bases, and exhibiting great variety in their capitals, from a simple square block to an elaborate composition of palm-leaves or other forms suggested by vegetation (fig. 2); the employment of a large concave moulding in the entablature, decorated with vertical flutings or leaves; walls and columns decorated with a profusion of sculptures in outline or low-relief

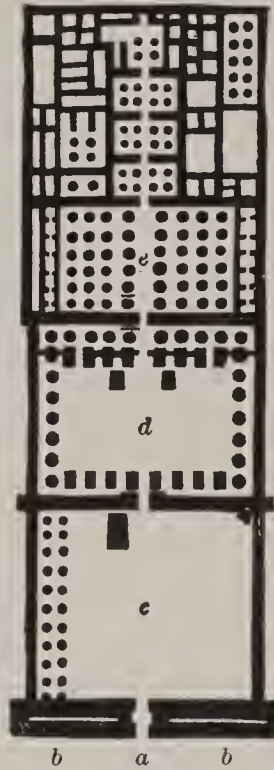

Fig. 1.—Plan of the Memnonium, Thebes.

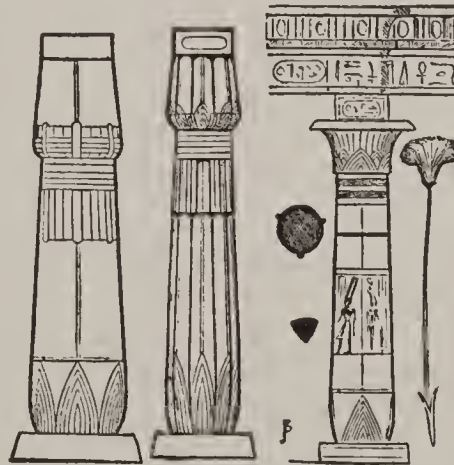

Fig. 2.—Types of Egyptian Columns.

Among its peculiar characteristics may be noted—symmetry of structure; the gradual converging of the walls of some of its edifices, especially of the propylæa or tower gateways of its temples; roofs and covered ways being flat, and composed of immense blocks of stone reaching from one wall or column to another, the arch not being employed nor yet timber; columns numerous, close, and massive, generally without bases, and exhibiting great variety in their capitals, from a simple square block to an elaborate composition of palm-leaves or other forms suggested by vegetation (fig. 2); the employment of a large concave moulding in the entablature, decorated with vertical flutings or leaves; walls and columns decorated with a profusion of sculptures in outline or low-relief

EGYPT.

representing divinities, men, and animals, colouring being often superadded. One with innumerable hieroglyphics, brilliant remarkable feature associated with this

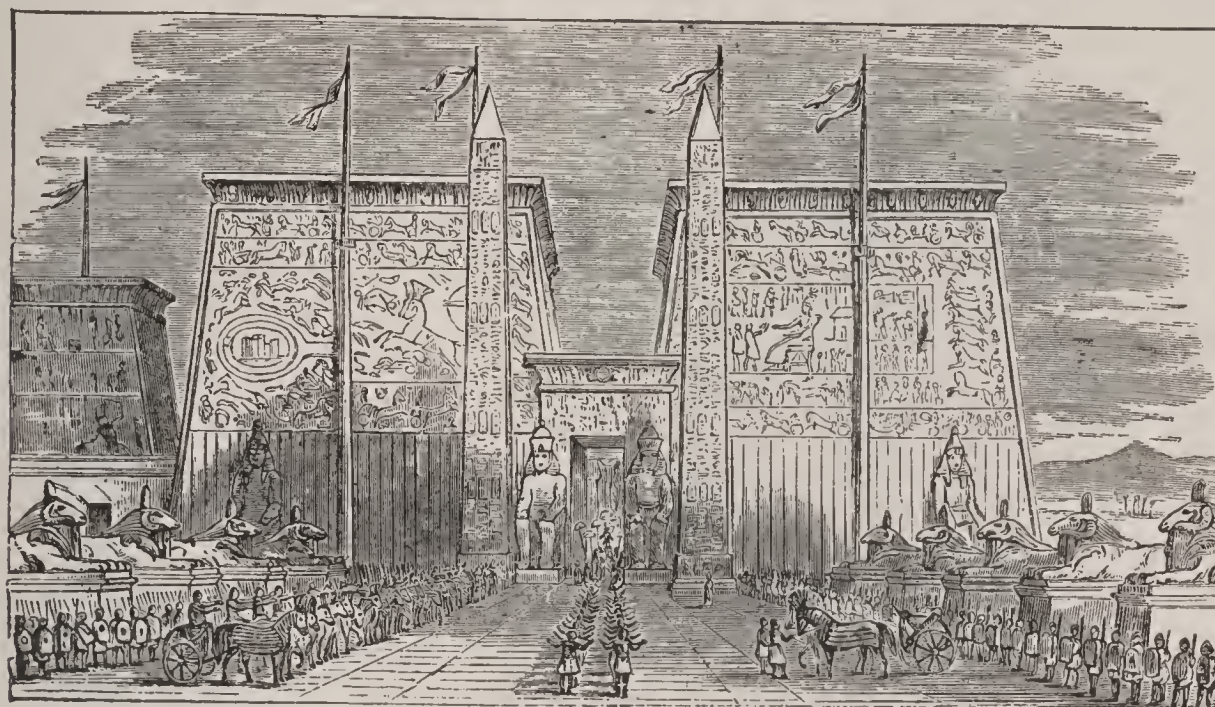

Fig. 3.—Restoration of the Propylon or Gate of the Temple of Luxor.

style is the grandeur of its mechanical operations in cutting, polishing, sculpturing, and transporting vast blocks of limestone and of granite. The pyramid is one of the best-known forms of Egyptian art, and there is little doubt that these structures were intended as the tombs of kings. The leading features of the Egyptian temples

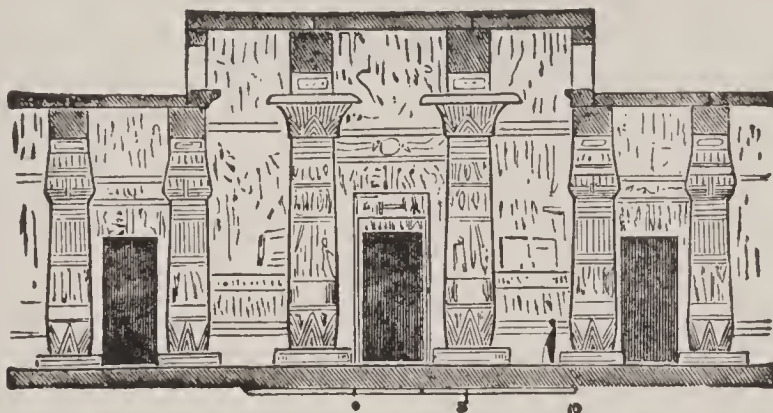

Fig. 4.—Hall of Columns in the Memnonium—Time of the Pharaohs.

c court). From this court the way leads through a second gateway to an inner court (*d*), surrounded by a colonnade. Beyond

this is the chamber of the temple known as the Hall of Columns (fig. 1 *e*, and fig. 4), the centre avenue of which was higher than the rest of the hall, and consisted usually of twelve columns, which supported a flat roof formed of massive

were these: a gateway flanked by two lofty pylons (fig. 3) formed the entrance to a square court (see fig. 1, *a* entrance, *b b* pylons,

stones, light being admitted at the sides of this elevated portion. To the Hall of Columns succeeded a series of smaller chambers, the roofs of which were generally sup-

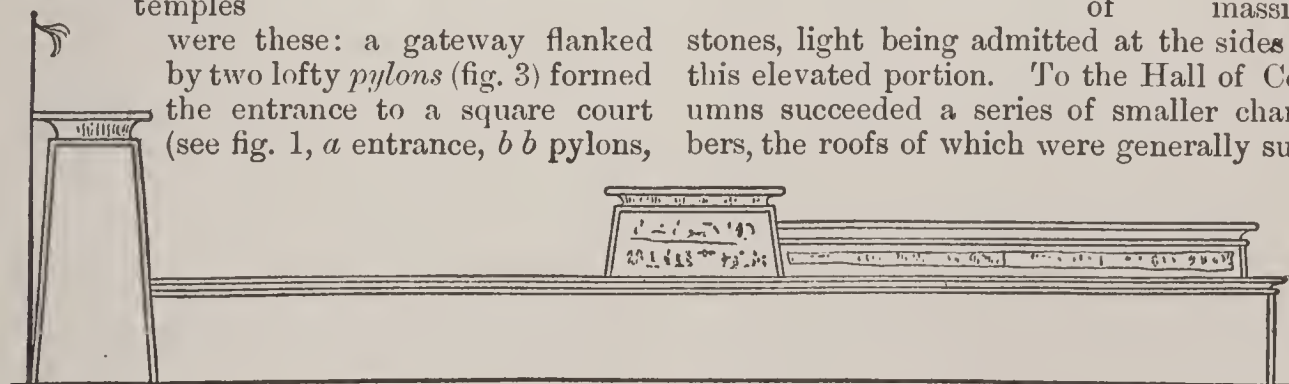

Fig. 5.—Side Elevation of Ptolemaic Temple at Edfou.

ported by six or four columns. These apartments frequently surrounded a dark chamber—the most sacred in the temple

—the holy of holies. The surface of each architectural feature was engraved with its particular ornament appropriately col-

oured. In the *cavetto*, or hollow moulding of the cornice, it was customary to place the name and titles of the Pharaoh or king; the architrave stone was symbolically ornamented with the names of the divinities to whom the temple was dedicated, and of the sovereign in whose time it was built. The abacus of the column was invariably decorated with the royal titles. The capitals were painted in accordance with the intention of the form; if, for instance, the expanded papyrus was shown, the leaves of the calyx would be yellow and the filaments green. Beneath were horizontal bands of blue and white, and then a representation of the king offering gifts to the gods of the temple; and lastly, the yellow and red lines at the base of the shaft signified the brown leaves that envelop the base of the stalk of the natural plant. The Egyptian temple was invariably rectangular, with its walls inclining inwards, and never more than one story high, and the approach to it was frequently through an avenue of sphinxes (fig. 3). The

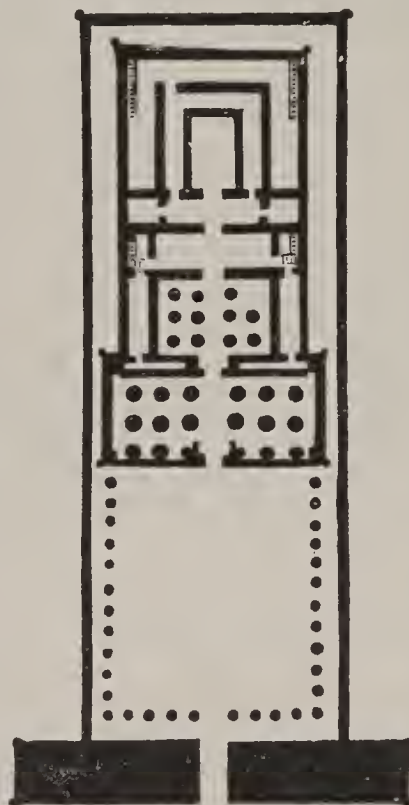

Fig. 6.—Plan of Ptolemaic Temple at Edfou.

temples built during the sway of the Greeks and Romans, though having a general resemblance to the earlier ones, differed in some respects, as in the use of more elaborate capitals, more salient forms in the architectural and sculptural decorations, &c. (The side elevation of a Ptolemaic temple is shown in fig. 5, the plan in fig. 6.) A peculiar kind of mural sculpture was practised among the Egyptians, the outline of the object to be represented being cut into the surface, while the minor forms and roundness are shown within this incised outline, thus forming a kind of 'hollow relief.' For further illustrations of Egyptian architecture, see *Architecture, Esneh, Karnak*; and for an account of the hieroglyphics of ancient Egypt see *Hieroglyphics*.

Egyptian Bean, a name sometimes given to the bean-like fruits of the *Nelumbium speciosum*, or sacred lotus, found in China, India, Australia, but no longer on the Nile.

Egyptian Blue, a brilliant pigment consisting of the hydrated protoxide of copper mixed with a minute quantity of iron.

Egyptian Vulture (*Neophron percnopterus*), a bird that frequents both shores of the Mediterranean, but rarely passes farther north, though it has been found in the British islands. It is one of the smaller vultures, about the size of a raven. The general colour is white, the quill feathers of the wing being dark brown. It frequents the streets of eastern towns, where it is protected on account of its services as a scavenger.

Egyptology, the science of Egyptian antiquities, or that branch of knowledge which deals with the language, history, &c., of ancient Egypt.

Ehrenberg (*ā' rēn - berh*), CHRISTIAN GOTTFRIED, a German scientist, born in 1795, died in 1876. After studying theology, medicine, and natural history, he joined in 1820 an expedition to Palestine, Egypt, and Abyssinia, returning to Berlin in 1825. In 1829 he accompanied Humboldt to the Ural and Altai ranges and to Central Siberia. His great work on Infusoria appeared in 1838, and was at once recognized

as the highest authority on the subject. It was followed in 1854 by his *Microgeology*.

Ehrenbreitstein (*ā' rēn - brīt - stīn*), a Prussian fortress of great strength situated opposite the confluence of the Moselle with the Rhine, on a precipitous rock 387 feet above the river, and inaccessible on three sides. It is connected with Coblenz on the opposite shore by a bridge of boats. The fortifications, which were erected in 1816-26 at a cost of \$6,000,000, can accommodate a garrison of 14,000 men, and possess room for stores to last an army of 60,000 for a year.

Eibenstock (*i' ben - stok*), a town in the south-east of Saxony, with important manufactures of lace. Pop. 6707.

Eichhorn (*ih' horn*), JOHANN GOTTFRIED, German orientalist, historian, &c., born in 1752. He became professor of oriental languages at Jena, and then at Göttingen. He died in 1827. Amongst his works are the *Hebrew Prophets*; *History of Literature*; *History of the Three Last Centuries*; *Introductions to the Old and New Testaments* and to the *Apocrypha*.

Eichstätt (ī'h'stet), an old town, Bavaria, in a deep valley of the Altmühl, 67 miles N.N.W. of Munich. Its principal edifice is a fine Gothic cathedral, founded in 1259. Pop. 7489.

Eider (ī'dër), a river of Prussia, which rises in Holstein, and forms the boundary between Schleswig and Holstein, falling into the North Sea at Tönning after a course of 92 miles. By its junction with the Schleswig-Holstein Canal it gives communication between the North Sea and the Baltic.

Eider Duck (*Somateria mollissima*), a species of duck found from 45° north to the



Eider Duck (*Somateria mollissima*).

highest latitudes yet visited, both in Europe and America. Its favourite haunts are solitary rocky shores and islands. In Greenland and Iceland they occur in great numbers, and also breed on the western islands of Scotland. The eider duck is about twice the size of the common duck, being about 2 ft. 3 in. in length, 3 feet in breadth of wing, and from 6 to 7 lbs. in weight. The male is black, head and back white, with a black crown. The female is reddish drab spotted with black, and with two white bands on the wings. They feed largely on shell-fish, crustaceans, &c. Their nests are usually formed of drift grass, dry sea-weed, &c., lined with a large quantity of down, which the female plucks from her own breast. In this soft bed she lays five eggs, which she covers over with a layer of down. If this, with the eggs, is removed the bird repeats the process. One female generally furnishes about $\frac{1}{2}$ lb. of down, but the quantity is reduced by cleaning. This down, from its superior warmth, lightness, and elasticity, is in great demand for beds and coverlets; and the districts in Norway and Iceland where these birds abound are guarded with the greatest vigilance as a most valuable property. As found in commerce this down is in balls of the size of a man's fist, and

weighing from 3 to 4 lbs. It is so fine and elastic that 5 lbs. of the best quality is sufficient for a whole bed. The down from dead birds is little esteemed, having lost its elasticity. The king eider duck (*Somateria spectabilis*) is another species resembling the preceding and inhabiting the same coasts.

Eigg (eg), an island on the west coast of Scotland, county of Inverness, about 10 miles from the mainland, and 5 miles long by about 3 broad. It has bold, rocky shores, and terminates to the south in a lofty promontory called the Scur of Eigg, with a peak of columnar pitchstone porphyry 1339 feet above the sea, and on one side perpendicular as a wall. It is the scene of the massacre, towards the end of the 16th century, of the Macdonalds by the Macleods of Skye, who suffocated them in a cave where they had taken refuge. Pop. 291.

Eight-hour Law, an act adopted in 1868 by the United States congress, and afterward by a number of the state legislatures, providing that in all government employment eight hours shall constitute a day's work.

Eikon Basiliké (ī'kon ba-sil'ī-kē; Greek, 'the royal image'), the name of a book published shortly after the execution of Charles I. in January 1649, and supposed by some to have been written by the king himself. At the Restoration Gauden, afterwards Bishop of Worcester, laid claim to the authorship, and a memorandum in the copy of the Earl of Anglesea, lord privy-seal under Charles II., affirms his claim with the authority of Charles II. and the Duke of York. 48,000 copies were sold within a year of its publication, and the republicans put forward Milton to answer it, his *Eikonoklastes* (that is 'image-breaker') appearing the same year, by order of parliament. The *Eikon Basilikē* professes to be a sort of private journal of the king, written in an affectedly dignified strain, and containing numerous assertions of love for his misguided and ungrateful people.

Eildon Hills (ēl'don), three picturesque, conical shaped hills, south of Melrose, Roxburghshire, Scotland, reaching a height of about 1400 feet, said to have been cleft in three by Thomas the Rhymer.

Eileithyia (ī-lī-thī'ya), an ancient Egyptian city, on the Nile, some distance above Esneh. Important remains have been obtained from rock-tombs in the neighbourhood, and there are several ruined temples. Modern name, El Kab.

Eilenburg (i'lén-burh), a town, Prussian Saxony, 26 miles N.N.E. of Merseburg, on an island of the Mulde. It has manufactures of calico, &c. Pop. 11,032.

Eimbeck (im'bek), or EINBECK, a town of Prussia, province of Hanover, on the Ilme, near its junction with the Leine, 40 miles south of Hanover. Pop. 6189.

Einsiedeln (in'zē-déln), a village and district, Switzerland, in the canton and 9 miles north by east of Schwyz, 3000 feet above the sea, celebrated for its Benedictine abbey. An image of the Virgin, alleged to possess miraculous powers, annually attracts immense numbers of pilgrims. Pop. 7633.

Eirenikon (i-rē'ni-kon), a name given to works having as their object the reconciliation of opposite schools in politics or theology.

Eisenach (i'zén-áh), a town of Germany, in the grand-duchy of Saxe-Weimar, near the mountains of Thuringia, at the junction of the Nesse and Hörsel. It is an attractive town, and contains a grand-ducal castle. It has manufactures of pottery, leather, woollen yarn, &c. Sebastian Bach was born here in 1682. Near it lies the Wartburg, where Luther was kept for safety in 1521-22. Pop. 19,641.

Eisenberg (i'zén-berh), a town of Germany, duchy of Saxe-Altenburg, with a ducal palace and various manufactures. Pop. 6901.

Eisk. See IEISK.

Eisleben (is'lā-bén), a town, Prussian Saxony, 25 miles north-west of Merseburg, celebrated as the place where Luther was born and where he died. There are many memorials of Luther, and also a bronze statue of the reformer erected in 1883. Copper is extensively worked in the neighbourhood. Pop. 23,175.

Eisteddfod (i'steth-vōd), an ancient assembly of Welsh bards for the purpose of musical and poetical contests, the judges being originally appointed by commissions from the native princes, and after the conquest from the English kings. The last was issued in 1568, but the ancient custom was revived in 1798 by the Gwynnedigion Society, and on a more elaborate scale by the Cambrian Society, which grew out of the Gwynnedigion. Eisteddfods are now held annually.

Eject'ment, in law, an action wherein the title to lands and tenements may be tried and the possession recovered. It is commenced by a writ addressed to the tenant

in possession and all entitled to defend the possession, bearing that the plaintiff lays claim to the property in question, and calling upon all interested to appear within a certain time to defend their right, failing which the tenant in possession will be ejected. In its older form the action was remarkable for certain curious legal fictions on which procedure was based; and the names of John Doe, an imaginary plaintiff, and of Richard Roe, an equally imaginary defendant, were long familiar in cases of this kind in the English courts.

Ejoo, a kind of fibre. See *Gomuti*.

Ekat'erinburg, a town, Russia, in the government and 170 miles S.E. of Perm, founded in 1723 by Peter the Great. It is the centre of the mining and metallurgy of the Ural region; and gem-cutting, the making of machinery, cloth, candles, &c., are industries. Pop. 36,750.

Ekat'erinodar, a town of Russia in the Caucasus, chief town of the Kuban territory, on the river Kuban, a poorly-built place with a considerable trade. Pop. 47,620.

Ekat'erinoslav, a town of southern Russia, capital of a government of the same name, on the right bank of the Dnieper, 250 miles N.E. of Odessa. It was founded in 1787 by Prince Potemkin, and consists of a number of long, broad, and dirty streets. Pop. 49,201.—The government, which is intersected by the Dnieper and at one point reaches the Sea of Azov, mostly consists of steppes; area 26,140 sq. miles; pop. 1,874,162.

Elæagna'ceæ, the oleaster family of plants, a small natural order of apetalous exogens found in every part of the Northern hemisphere, but is comparatively rare south of the equator. It includes 4 genera and 30 species.

Elæ'is, a genus of palms of which the African oil-palm (*Elæis guineënsis*) is one of the most important.

Elæocar'pus, a genus of trees, nat. order Tiliaceæ, natives of India and Australia and the isles between. The fruit is used in curries or pickled like olives.

Elæoden'dron, a genus of Asiatic and African trees, order Celastraceæ, some of which yield useful oils and timber.

Elæom'eter, a hydrometer for testing the purity of olive and almond oils, by determining their densities.

Elæop'tene, the liquid portion of volatile oils, as distinguished from the concrete or crystallizable portion called *stearoptene*.

Elagab'alus. See *Helioabalus*.

Ela'in, the oily principle of fat obtained by submitting fat to the action of boiling alcohol, allowing the stearin to crystallize, and then evaporating the alcoholic solution. It possesses much the appearance and properties of vegetable oil, and forms soaps with alkalies.

E'lam, the ancient name of a country or region in Asia, east of the Lower Tigris. A king of Elam is said in the cuneiform inscriptions to have conquered Babylonia and Assyria about 2300 B.C. It was latterly incorporated in the Persian Empire.

E'land, *Oreas Canna*, a species of antelope inhabiting Africa, the largest of all



Eland (*Oreas Canna*), male, female, and young.

the antelopes, being about the size of an ox. Its flesh, especially that of the thighs, which are dried and used in this state, is highly prized, and consequently the animal is now nearly exterminated in the neighbourhood of Cape Colony, where it was once common. The colour is a light or grayish brown, and it possesses a short mane. The horns, which are about 18 inches long and nearly straight, are spirally keeled.

El' Janet, the name of certain species of raptorial birds of the genus *Elanus*, and nearly allied to the kites. Such are the black-winged falcon (*E. melanopterus*) of Africa, Asia, and New Zealand, and the black-shouldered hawk (*E. dispar*) of America.

E'laps, a genus of poisonous snakes, the type of the family Elapidæ, to which belongs the cobra di capello.

Elasmobranchii (-brang'ki-ī), an order of fishes, including the sharks, dog-fishes, rays, and chimæra, in which the skull is not composed of distinct bones, but simply forms a kind of cartilaginous box, the vertebral column sometimes cartilaginous, sometimes consisting of distinct vertebræ, the integumentary skeleton in the form of placoid scales, the intestine being very short, and provided with a spiral valve. They have two pairs of fins (pectorals and ventrals), corresponding to the fore and hind limbs, and the ventral fins are close to the anus. The heart consists of an auricle, a ventricle, and a muscular arterial bulb. The gills are fixed, and form a number of pouches, which open internally into the pharynx, communicating outwardly by a series of apertures placed on the side of the neck.

Elas'modon, a sub-genus of the genus *Elephant*, under which are included the mammoth and Asiatic species, the African elephant belonging to the sub-genus *Loxodon*.

Elasmothe'rium, an extinct genus of mammalia, found in the post-pliocene strata of Europe, comprising animals of great size allied to the rhinoceros, and having two horns the one behind the other.

Elastic Bitumen, ELATERITE, or MINERAL CAOUTCHOUC, an elastic mineral resin of a blackish-brown colour, and subtranslucent.

Elastic'ity is the property in virtue of which bodies resist change of volume and change of shape, and recover their former figure or state after external pressure, tension, or distortion. The former is called elasticity of volume, the latter elasticity of shape. The name *Compressibility* is also used in connection with the elasticity of volume; and *Rigidity*, or resistance to change of shape, in connection with the latter. Fluids possess no rigidity whatever; they offer no *permanent* resistance to change of shape; while a solid body, unless it is distorted beyond certain limits, called the *limits of elasticity*, tends to return to its original form. Both fluids and solids possess elasticity of volume, and tend to resume their original volume after compression. The elasticity of volume of the former is perfect; whatever compression they have been subjected to, they return under the same conditions of temperature to precisely their original volumes when the forces of

compression are removed. In the case of solids there are limits to their elasticity of volume as well as to their elasticity of form; thus gold may be made permanently denser by hammering. There is one law of elasticity, the celebrated law of Hooke—*Ut Tensio sic Vis*, which translated into the modern language of elasticity stands—*Strain is proportional to stress*; or, in other words, whatever be the nature of the distortion the amount of it is proportional to the stress that produces it. This law is only considered as applicable so long as we do not go beyond the limits of elasticity. See also *Boyle's Law*.

El'ater, the name of a family (Elateridæ) of beetles, remarkable for their ability to throw themselves to a considerable height in the air, when placed on their back, by a vigorous muscular movement. Hence their names of springing-beetles, click-beetles, skip-jacks, &c. When alarmed, the elater counterfeits death. Flowers, grass, and decaying wood are the habitations of these animals, which are almost always found singly. The larvæ are often very injurious to vegetation, especially those which devour the roots of herbaceous plants (as in the genus *Agriotes*), and are known from their slenderness and hardness as wire-worms. The fireflies of America belong to the family. They possess luminous properties, which are unlike those of the glow-worm, &c., being seated near the head. The *Pyrophorus noctilucus*, called *cocuyo* in Brazil, is used as a personal ornament by ladies. The largest species of the genus *Elater*, the *Elater flabellicornis*, is $2\frac{1}{2}$ inches in length.

Elate'rium, a substance obtained from the fruit of the squirting or wild cucumber (*Ecballium agreste*). The juice of the unripe fruit when expressed and allowed to stand deposits elaterium as a green sediment with an acrid taste, a faint odour, and powerful cathartic properties. It is a violent purgative, and is poisonous, but its action is not constant. The active principle in it is called *elaterin*.

Elatina'ceæ, the water-pepper family, a natural order of herbaceous annuals found in marshy places in all quarters of the globe.

Elba (Lat. *Ilva*), a small island in the Mediterranean, in the province of Livorno (Leghorn), Italy, separated from the mainland by the Strait of Piombino, about 6 miles wide. The island is 18 miles long and from $2\frac{1}{2}$ to $10\frac{1}{2}$ miles broad, and is traversed by mountains rising to a height of

over 3000 ft. It is rich in iron, marble, granite, salt, &c.; and iron ore is exported. Excellent wine and fruits are produced. It has two seaports—Porto-Ferrajo (the capital) and Porto-Longone. The Treaty of Paris in 1814 erected Elba into a sovereignty for Napoleon, who resided in it from May 4, 1814, to February 26, 1815. Pop. 24,000.

Elbe (elb; Ger. pron. el'be; Lat. *Albis*; Bohemian, *Labe*), a river of Germany, one of the largest in Europe. It rises on the s.w. slopes of the Schneekoppe or Snowcap, one of the Riesengebirge, between Bohemia and Silesia. From this point it flows nearly due s. into Bohemia for about 50 miles, when it turns to the w., and after about 40 miles takes a general N.N.W. direction till it falls into the North Sea, intersecting Saxony, a considerable portion of Prussia, and in the latter part of its course separating Holstein on its right from Hanover on the left. The length, including windings, is upwards of 780 miles. The principal affluents are, on the right, the Iser, Schwarz-Elster, and Havel; on the left, the Alder, Moldau, Eger, Mulda, and Saal. In the lower part of its course the river is divided by five large and seven small islands into several arms, which unite again about 5 miles below Hamburg. The mean depth is 10 ft., average breadth 900 ft. It is more or less navigable for about 470 miles, but its estuary at Cuxhaven is much encumbered with sand-banks. It is well stocked with fish. On 1st July, 1870, the navigation of the Elbe was declared free from Hamburg to Melnik in Bohemia.

Elberfeld (el'bér-felt), a town of Rhenish Prussia, in the government of and 15 miles E. of Düsseldorf, on both sides of the Wupper, inclosed by lofty hills. Taken with Barmen it stretches along the Wupper valley for about 6 miles. It has no historical or antiquarian importance, its prosperity, which is of recent date, being largely due to the cotton manufacture, of which it is the centre in Rhenish Prussia. Linen, woollen, silk, and mixed silk goods, ribbons, and velvet are extensively made and exported. There are numerous mills for spinning cotton twist, linen yarn, and worsted, and numerous dye-works, and miscellaneous industrial establishments. The environs are mostly taken up with bleach-fields. Pop. 1890, 125,830; with Barmen, 242,078.

Elbeuf (el-beuf), a town of France, dep. Seine-Inférieure, 11 miles s.s.w. of Rouen,

in a valley on the left bank of the Seine. It is well built, and has eight artesian wells. It has spinning-mills, dye-works, and is an important centre for the production of woollen manufactures, chiefly of lighter cloths and fancy goods. It is also an entrepôt for the finer and heavier cloths of Louviers and Sedan. It communicates by steamers with Paris, Rouen, and Havre. Pop. 21,173.

Elbing, a seaport town of West Prussia, on the Elbing, near its entrance into the Frische-Haff. It was once a flourishing Hanse town, and is still a place of considerable industry and trade, the manufactures including iron goods, machinery, brass and tinplate goods. It has also ship-building yards. Pop. 38,278.

El'bruz, a mountain summit of the Caucasus (which see).

Elburz, a lofty mountain range extending over Northern Persia, parallel with and overlooking the Caspian. Highest peak, Mt. Demavend, 19,400 ft.; average height, 6000 to 8000 ft.

Elca'ja, an Arabian tree (*Trichilia emetica*), the fruit of which is used as an emetic, and to compose an ointment to cure the itch.

Elcesaites (el-ses'a-its), a sect of Gnostics which arose in the reign of Trajan about the beginning of the 2d century. They were a branch of the Essenes and resembled the Ebionites. A Jew, named Elxai, or Elkesai, is their reputed founder.

Elche (el'chā), a town of Spain, in the province and 14 miles w.s.w. of Alicante, on the left bank of the Vinalopo, surrounded by palm-trees. It contains various Roman remains, a fine church, and a townhouse of the 15th century. Chief industry, the culture of dates. Pop. 18,734.

Elchingen (el'hing-en), Ober and Unter, two villages of Bavaria, on the left bank of the Danube, about 3 miles apart and 8 north-east of Ulm. In 1805 Marshal Ney defeated the Austrians at Ober Elchingen, and won for himself the title of Duke of Elchingen.

Elder, a name given to different species of the genus *Sambucus*, nat. order Caprifoliaceæ. These are small trees or shrubs, with opposite and pinnated leaves, bearing small white flowers in large and conspicuous corymbs, small berries of a black or red colour, and bitter and nauseous leaves possessing purgative and emetic properties. The wood of the young shoots contains a very large proportion of pith. The common

elder of Britain (*S. nigra*) is a wild shrub or small tree, distinguishable by its winged leaves; its clusters of small, cream-white flowers, and the small black berries by which these are succeeded, and from which a kind of wine is sometimes made. The dwarf elder or dane-wort (*S. Ebulus*) is also found in many parts of Britain, and was vulgarly supposed to have sprung from the blood of the Danes. Two species inhabit North America: *S. canadensis*, a common plant from the 49th to the 30th parallel of latitude, the berries of which are black and have a sweet taste; and *S. pubescens*, which bears red berries, and inhabits Canada, the northern parts of New England, and the Alleghany Mountains. Elder wood is yellow, and in old trees becomes so hard that it is often substituted for box-wood. Its toughness also is such that it is made into skewers, tops for fishing-rods, &c. The light pith is utilized for balls for electric experiments, and various ointments, drinks, and medicinal decoctions are made from the bark, leaves, flowers, and berries.

Elders, persons who, on account of their age, experience, and wisdom, are selected for office, as, among the Jews, the seventy men associated with Moses in the government of the people. In the modern Presbyterian churches elders are officers who, with the pastors or ministers, compose the consistories or kirk-sessions, with authority to inspect and regulate matters of religion and discipline in the congregation. As a member of the kirk-session the elder has an equal vote with his minister, and as a member of the higher church courts, when delegated thereto, he has a right to reason and vote on all matters under discussion in the same manner as the clergy themselves.

Eldon, JOHN SCOTT, EARL OF, Lord-chancellor of England, was born in 1751 at Newcastle-on-Tyne, where his father was a coal-dealer and public-house keeper of means. He was educated with his brother William (afterwards Lord Stowell) at Newcastle, and at Oxford, where he obtained a fellowship. He was called to the bar in 1776, and in 1782 was made king's counsel. Next year he entered parliament, supported Pitt, and was made solicitor-general, and knighted. In 1792 he purchased the estate of Eldon. In 1793 he became attorney-general, and in 1799 was created chief-justice of the Court of Common Pleas, and raised to the peerage and the House of Lords by the title of Baron Eldon. On the accession

of the Addington ministry he became lord-chancellor (1801), and retained this post under the subsequent administration of Pitt until the death of the latter in 1806. A year later, however, he resumed the chancellorship under Liverpool, and held it without break for twenty years. In 1821 he was created an earl by George IV. On the accession of the Canning ministry in 1827 he resigned the chancellorship, and never again held office. He died in London in 1838 at the age of eighty-six. As a lawyer he was a master of English jurisprudence; as a politician he was opposed to reform, and by no means free from the charge of servility and intrigue.

El Dora'do, a country that Orellana, the lieutenant of Pizarro, pretended he had discovered in South America, between the Orinoco and Amazon rivers; and which he named thus on account of the immense quantities of gold and precious metals which, he asserted, he had seen in Manoa, the capital of the country.

Eleanor Crosses (el'i-nor), memorial crosses erected on the spots where the bier of Eleanor, the wife of Edward I., rested on its way from Grantham to Westminster. Thirteen were erected, but only three, those of Northampton, Geddington, and Waltham, remain.

Eleat'ic School, a Grecian philosophical sect, so called because it originated in Elea (Latin, *Velia*), a town of Magna Græcia (Southern Italy), of which also three of its most celebrated teachers, Parmenides, Zeno, and Leucippus, were natives. The founder was Xenophanes of Colophon, who came to Elea late in life, bringing with him the physical theories of the Ionian school, to which he added a metaphysic. The two schools soon drifted widely apart especially in respect of method. Starting from the observation of external nature, the Ionians endeavoured to discover some elementary principle, as water, air, fire, or a combination of elements, by the action of which the phenomena they observed might be accounted for. The Eleans made the abstract idea of Being or God, deduced from the contemplation of the universe as a whole, their starting-point; and their reasonings sometimes led them to deny the reality of external phenomena altogether.

Elecampane (el-i-kam-pān'; *Inŭla Helēnium*), a plant of the natural order Compositæ, found in the United States and Europe, and in Asia. It is 3 or 4 feet high; the radical

leaves are often 2 feet and more in length; the flowers are large and yellow; the root, which is perennial, possesses a bitter camphor-like taste. It was formerly much used as a stimulant for all the secreting organs.

Election, in theology, the doctrine that God has from the beginning elected a portion of mankind to eternal life, passing by the remainder. It is founded on the literal sense of certain passages of Scripture, and has been amplified by the labours of systematic theologians into a complete and logical system. It dates in ecclesiastical history from the time of Augustine; but Calvin has stated it so strongly and clearly in his Institutes, that it is generally associated with his name.

Election, in politics, the selection by voting of a person or persons to occupy some post or office. The most important elections are those of the members of the legislative assemblies of the different countries, and as to the manner in which these are carried out strict laws are in force. In such elections voting by ballot (see *Ballot*) is now general. The chief forms of election in Britain are parliamentary and municipal elections, in both of which the basis of the suffrage (or right of voting) is the payment of poor-rates. Members of parliament formerly required a property qualification in England and Ireland; but this restriction, which never existed in Scotland, has been abolished. In both parliamentary and municipal elections the ballot has been in operation since 1872. For the prevention of bribery and corrupt practices many acts have been passed, of which that now in operation came into force in October, 1883, and has been annually renewed since 1884. Jurisdiction of election laws of the United States extends to such officers of Federal Government as are elective, viz., the President, Vice-President, and members of the House of Representatives. The election of officers of the State governments is regulated by the several State codes. The President and Vice-President are elected by a college of electors, which college is composed of as many electors as there shall be Senators and Representatives in Congress at the time of the appointment of such electors. The people vote directly for these electors. Members of Congress are elected as follows: each State is entitled to two Senators in Congress, who are elected by the Legislatures of the several States; members of the House of Repre-

representatives are elected directly by the people. All citizens of the United States are entitled to vote except citizens of the District of Columbia. In 1870 persons of African descent were given the right to participate in elections. The States of the Union from time to time enact laws for the regulation and management of their local elections, embracing the choice of the officers of the State, city and county. The constitutions of the several States secure to citizens the right of suffrage. The laws of each State provide the means of effecting the ends of the constitution, and prescribe the qualifications of voters, which vary somewhat in the different States. In all the States the following qualifications may be classed as universal: that the elector shall be over twenty-one years of age, neither a lunatic nor a pauper, and prepared to take, if necessary, an oath of allegiance to the Federal Government. The length of residence in the State previous to an election is fixed by the State law and varies in the different States. Property qualification is required only in Rhode Island. Some of the States require an ability to read and write. In the States of Wyoming and Colorado the right of suffrage is extended to women.

Elector (German, *Kurfürst*, 'electoral prince'), the title of certain princes of the old German Empire who had the right of electing the emperors. There were ten in 1806, when the old empire was dissolved.

Electoral Commission, a commission provided for by act of congress, Jan. 29, 1877, to settle disputed questions in regard to the electoral votes of several states in the presidential election of 1876. It was composed of five senators, chosen by the senate; five members of the house of representatives, chosen by the house; and five associate justices of the supreme court, four of whom were designated by the act of congress, and the fifth selected by the four. It was found, on counting the electoral votes in the presence of the two houses of congress, there were conflicting certificates from four States—Louisiana, Florida, Oregon, and South Carolina. These certificates, were referred to the commission, which by a vote of eight to seven—following the line of party division in the commission—decided that the certificate of electoral votes cast for Hayes and Wheeler was the legal certificate. The decision of the commission, according to the terms of the statute, be-

came irrevocable; the disputed votes were counted accordingly; and Hayes and Wheeler were found duly elected, by a majority of one electoral vote. The important question before the commission was whether an electoral certificate being in form confessedly according to law, it was competent for congress or the commission to go behind the same and take evidence *aliunde* in support of alleged irregularities committed before such certificate was issued. The majority of the commission took the negative.

Electric Battery, the original name of what is now more commonly called a battery of Leyden-jars, the old name having been given before galvanic batteries were invented. See *Leyden-jar*.

Electric Clock, a clock driven or controlled by electricity, the latter being the ordinary meaning of the term. One clock driven in the ordinary way can be made to control by electric currents another clock (or clocks) also driven in the ordinary way so as to make it keep accurate time. The method of R. L. Jones, more or less modified, is now in very extensive use. By means of it one high-class clock (usually in an astronomical observatory) compels a number of other clocks at considerable distances to keep time with it. The clocks thus controlled ought to be so regulated that if left to themselves they would always gain a little, but not more than a few minutes per day. The pendulum of the controlling clock, in swinging to either side, makes a brief contact, which completes the circuit of a galvanic battery, and thus sends a current to the controlled clock. The currents pass through a coil in the bob of the pendulum of the controlled clock, and the action between these currents and a pair of fixed magnets urges the pendulum to one side and to the other alternately. The effect is that, though the controlled clock may permanently continue to be a fraction of a second in advance of the controlling clock, it can never be so much as half a second in advance. An electrically-controlled clock usually has close beside it a small magnetic needle, which moves to the one side or the other according to the direction of the current, and thus shows whether the currents are coming. The arrangements are usually such that at every sixtieth second (that is at every exact minute) no current is sent, and the needle stands still. Any small error is thus at once detected.

ELECTRICITY.

Electricity, the name given to the unknown cause of certain effects of very various kinds which are found to be closely connected one with another. They include two distinct kinds of attraction and repulsion (*electrostatic* and *electrodynamic*), the magnetization of iron, the deflection of magnetic needles, the production of heat and light in certain circumstances, the separation of certain chemical compounds into their constituents, and spasmodic actions on the nervous and muscular systems of animals. The name is derived from the Greek *electron*, amber, the fact that amber when rubbed attracts light particles, such as small pieces of paper, having been known to the ancient Greeks. Friction was the only artificial source of electricity employed until Galvani, near the close of last century, accidentally obtained it by the contact of two metals with the limbs of a frog; and Volta, developing Galvani's discovery, invented the first galvanic or voltaic battery. Electricity produced by friction is called *frictional electricity*; that produced by chemical action on metals, *voltaic electricity*.

Conductors and Non-conductors.—All substances which, like amber, could be made to show electrical attraction by rubbing them, were called *electrics* by early writers on electricity. They included glass, amber, sulphur, shellac, rosin, silk, flannel, &c. The name *non-electrics* was given to other bodies which were supposed not to be susceptible of excitation by friction. The bodies called non-electrics were also called *conductors*, from the power which they exhibited of allowing electricity to pass through them. Electrics were also called *non-conductors*. The names conductor and non-conductor are still retained, but the names electric and non-electric are discarded as being founded on a mistake. Electricity can be excited by the friction of a conductor against a non-conductor, and is, in fact, so excited in the ordinary electrical machine, in which glass rubs against an amalgam spread on a cushion. (See *Electric Machine*.) A metallic rod furnished with a glass handle can be electrified by rubbing it with flannel, the glass preventing the electricity from being conducted away through the hand. Substances thus electrified exhibit two opposite kinds of electricity, known respectively as *positive* and *negative*. Bodies charged with the same kind of electricity repel each other; those charged with opposite kinds attract each

other. An instrument for indicating the presence of electricity is called an *electroscope* (which see).

Electric Conduction.—All solid and liquid substances allow electricity to pass through them to some extent, but the differences of degree are enormous. The best conductors are the metals, especially gold, silver, and copper. Perfectly pure copper conducts about seven times as well as iron. Substances which have excessively small conducting power are not called conductors, but *insulators*, so that a good insulator is another name for an excessively bad conductor. Among the best insulators may be mentioned glass, paraffin (the wax, not the oil), ebonite, shellac, mica, india-rubber, and gutta percha. The ratio of the conducting power of a metal to that of one of these substances is about a thousand million billions to one. Water occupies an intermediate position between these two extremes. In experiments with frictional or influence machines it behaves as a conductor, but in experiments with galvanic batteries it behaves as an insulator. The word *resistance* is used in the opposite sense to conducting power; a good insulator is said to have high resistance, and a good conductor to have low resistance.

Electrostatics is that branch of the general science of electricity which treats of the repulsions between like and the attractions between unlike kinds of electricity. The fundamental law of electrostatics is that if e and e' denote two quantities of electricity collected in two spaces very small in comparison with the distance between them, the mutual force which they exert upon each other is directly as the product ee' , and inversely as the square of the distance. If the two quantities ee' are both positive, or both negative, the force is a repulsion; but if one is positive and the other negative, it is an attraction. Electrostatic attractions and repulsions manifest themselves in two distinct ways, namely, (1) as attractions and repulsions between electrified bodies; (2) as producing changes in the distribution of electricity on conductors. This second effect is called *electrostatic induction*. The different portions of the charge of one and the same conductor act upon one another according to the general law of repulsion, and thus produce the actual distribution, which is entirely on the surface, all electricity being repelled from the interior. The interposition of an insulating substance be-

ELECTRICITY.

tween two quantities of electricity alters the amount of the forces which they exert upon each other. In a broad sense electrostatics may be held to include within its range all the phenomena of frictional electricity and of the electricity produced by influence machines, such as those of Holtz, Voss, and Wimshurst. (See *Electric Machine*.)

Electric Discharge.—The rapid escape of electricity from a charged body is an electric discharge. When the discharge takes place through a conductor it is called *continuous*, and when it takes place through a non-conductor (for example through air) it is called a *disruptive discharge*. The name 'electric discharge' is especially applied to cases in which the escaping electricity pro-

duces luminosity. Three kinds of such discharge have been distinguished—the *spark*, the *brush*, and the *glow*. The spark is accompanied by a sound which varies from a faint crack to a loud bang. In nature it is seen on the largest scale in the case of lightning, which is a discharge of atmospheric electricity. In many cases the electric spark presents no definite shape, but looks like a mere point of fire, or, if very bright, is enlarged by its dazzling effect on the retina; but when it leaps across a space of several inches of air it assumes a crooked shape bearing a remarkable resemblance to a flash of lightning. The *brush* discharge is only faintly luminous. It occurs especially at sharp points and edges of highly-charged

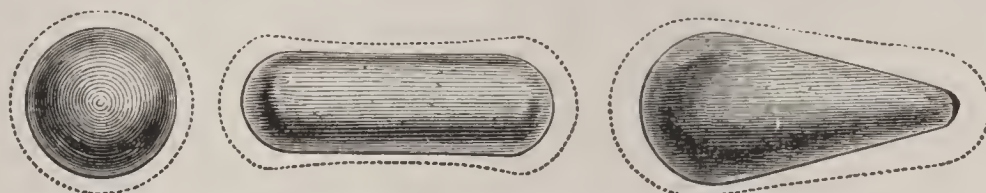

Distribution of Electricity—Relative Amounts on Curved Surfaces.

bodies. It is barely visible by daylight, and its appearance in the dark is that of a luminous halo. It projects only a small distance into the air surrounding the body from which the charge is escaping. The *glow* discharge simply renders the surface of the body luminous, and does not extend into the air at all. In some modern electric apparatus beautiful effects of electric discharge are shown. Thus by causing a discharge to take place in highly-rarefied air or gas it is made to jump across a considerable interval, and the whole intervening space is filled with a beautiful nebulous luminosity, the colour of which depends on the nature of the gas. If the vacuum is sufficiently good the luminosity is seen to be disposed in transverse stripes, technically called *striae*.

Dissipation of Electricity.—An electrified body left to itself gradually loses its electricity. This effect is due to more causes than one. If the body is a conductor and has any sharp points or edges, these afford a ready channel for the escape of the charge into the air. Some loss occurs by particles of dust in the air being attracted to the body and then repelled after coming in contact with it. But the chief loss in the case of a smooth conductor on insulating supports usually occurs by leakage over the surface of the supports, owing to a thin film of moisture from which it is difficult

to keep them free. This is especially the case with glass supports. Dissipation can be almost completely prevented by surrounding the electrified body with an artificially dried atmosphere. The most usual means of doing this is to place a shallow dish of sulphuric acid in the closed vessel in which the body is contained. The loss by dissipation can thus be reduced to one or two per cent of the entire charge per diem.

Distribution of Electricity.—When a conductor has a permanent charge, there is no electricity in its interior. The charge resides entirely at the surface, and is not *distributed* equally over the whole surface but is thickest (so to speak) at those parts which project most. The dotted lines in figs. above illustrate by their distances from the conductor, the thickness (technically called *density*) of the electricity at the different parts of the surface. At sharp edges, and still more at sharp points, the density is exceedingly great, and hence the electricity has a strong tendency to leak away.

Electric Currents.—What is known as an electric current is a peculiar condition of a wire or other conductor of electricity, in virtue of which it deflects magnetic needles in its neighbourhood, magnetizes a piece of soft iron round which it is coiled, has its own temperature raised, and exhibits various other effects. This condition

of a wire occurs both in connection with frictional and voltaic electricity, and can be produced by attaching its ends to the two terminals of a galvanic battery, or to the two terminals of a magneto-electric machine, and in various other ways. An electric current may be regarded at pleasure as consisting in the flow of positive electricity in one direction through the wire in question, or of negative electricity in the opposite direction, or of both electricities simultaneously one in each direction. What is conventionally called the direction of the current is the direction in which the positive electricity may be regarded as flowing. The 'strength' of a current denotes the quantity of electricity that passes through the wire in the unit of time. The deflecting force which a current exerts on a magnetic needle—other things being equal—is proportional to the strength of a current; but the quantity of heat which it generates in a given time is proportional to the square of its strength. One effect of currents is the decomposition of certain chemical compounds (see *Electrolysis*), and this effect, like that first mentioned, is simply proportional to the strength of the current. Instruments for measuring the strengths of currents by chemical decomposition are called *voltameters*, and instruments for measuring them by the deflection of magnetic needles are called *galvanometers*. (See these arts.) The currents by which telegraphs are worked are usually obtained from galvanic batteries; but the far stronger currents required for electric lighting are usually produced by machines called *dynamos* driven by steam or water power. (See *Dynamo*.) The currents in such machines are due to magneto-electric induction. (See *Induction*.)

Electro-dynamics is that branch of electrical science which treats of the attractions and repulsions exhibited between wires or other conductors through which currents are passing. If two wires are parallel, they will attract each other when currents are passing the same way through them both, and will repel each other when the currents are opposite. If the wires are inclined to each other at any angle, there is not only an attraction or repulsion, but a still more marked tendency to rotation, which is not satisfied till the wires have become parallel and the currents flow in the same direction through them both. When there are only two straight wires these forces are feeble and require delicate apparatus for their ex-

hibition; but by employing coils of wire the forces are multiplied, and an instrument constructed on this principle called the *electro-dynamometer* (which see) has been much employed for the measurement of currents. The whole science of electro-dynamics is due to Ampère, who discovered its main facts, and reduced them by ingenious experiments, combined with very abstruse reasoning, to a single mathematical formula which includes them all.

Velocity of Electricity.—Daily experience with the electric telegraph shows that electrical action is propagated with great rapidity. The time that intervenes between the sending of a signal from one station and its visible effect at another, depends on a variety of circumstances. The time is notably longer for underground or submarine wires than for wires suspended in the air on poles. When one end of a long submarine or subterranean telegraph wire is suddenly put in connection with a galvanic battery or other source of electricity, the current which flows out of the other end into the earth does not begin sharply but gradually, and takes a measurable time to attain its full strength. Hence an instrument which is delicate enough to show a very feeble current, will show the effect earlier than one which requires a strong current to move it. An instrument in which the moving parts are small and light has also an advantage over one in which they are large and heavy. Something, too, depends on the nature of the source of electricity employed. A source which acts with sudden violence, like the discharge of a Leyden-jar or an induction-coil, will make the effect appear earlier than a comparatively gentle source, such as an ordinary galvanic battery. Electricity has not a definite velocity like light or sound. It is rather comparable to waves on water, which travel with very various speeds according to their length and the depth of the water. The highest speed ever observed in the transmission of electric effects was that obtained by Wheatstone in his celebrated experiment with a rotating mirror. In this experiment a Leyden-jar was discharged through half a mile of wire with three interruptions in it, at each of which a spark was formed by the electricity leaping across. One interruption was in the middle, and the other two were at the ends, one end being close to the knob of the jar, and the other end close to its outer coating. The wire was so arranged that all three interruptions

were near together; and by observing the reflections of the three sparks in a rotating mirror, he was able to discover that the middle spark occurred sensibly later than those at the two ends, these latter being simultaneous. The lagging of the middle spark behind the other two was regarded as the time that electricity took to travel through a quarter of a mile of wire, and the velocity thus found for electricity was 230,000 miles per second, a velocity greater than that of light, which is between 185,000 and 186,000 miles per second. Observations made in connection with the use of the electric telegraph for determining longitudes, have shown that the time which intervenes between the sending and receiving of a signal was about four-tenths of a second between Aden and Bombay, two-tenths of a second between Alexandria and Malta, two-tenths between Malta and Berlin, and about one-eighth of a second between Greenwich and Valentia.

Electrical Theories.—If we endeavour to explain electrical phenomena by regarding electricity as a substance, we are met by two difficulties: one is that electricity adds nothing to the weight of a body; the other is that electrical phenomena are dual, as if there were two opposite kinds of electricity which destroy each other when they unite. Du Faye maintained the existence of two electrical fluids endowed with opposite qualities, and called them the *vitreous* and the *resinous* fluid. Franklin endeavoured to account for the same phenomena by assuming the existence of a single electric fluid, and supposing an electrified body to be a body which possesses either more or less than the normal quantity of this fluid. If more, it was said to be positively, and if less, negatively electrified. Franklin's *positive* and *negative* corresponded with Du Faye's *vitreous* and *resinous*. Whenever electricity is generated the two opposite kinds are always produced, and produced in exactly equal quantity. Modern theories favour the idea that electricity is not a substance or a pair of substances, but a special kind of motion, and that the two opposite electricities are two opposite states of motion of the particles of a medium which is believed to pervade all bodies and all space: the same medium whose vibrations constitute light.

Applications of Electricity.—The employment of electricity commercially and industrially is daily increasing in importance. The electric telegraph has long been familiar,

and the telephone is now almost equally so. Electric lighting is rapidly extending, and electric railways or tramways are increasing in number. The operations of electro-metallurgy are also of great importance. (See the separate arts.)

The Electric Transmission of Power is the transmission of power to a distance by electricity, effected by employing the source of power to drive a machine called a *dynamo* which generates an electric current. This current is conveyed by a copper conductor insulated from the earth to the distant station, where it passes through a machine called an *electro-motor* (see that art.), one part of which (called the armature) is thereby made to revolve, and imparts its motion to the machinery which is to be driven.

This is the simplest arrangement, and is that which is commonly employed when the original currents are not of such high tension as to be dangerous to life in the case of accidental shocks. There is, however, a great waste of power in employing low-tension currents when the distance is great; hence it is becoming a common practice to employ high-tension currents for transmission through the long conductor which connects the two stations, and to convert these into low-tension currents before they reach the houses or workshops where they are to be used. This is done sometimes by employing the high-tension currents to drive a local dynamo which generates low-tension currents, sometimes by employing them to charge storage cells arranged in long series, and afterwards connecting these cells in shorter series. The discovery that a Gramme machine is reversible—that is to say, when two Gramme machines are coupled together, one operating as a generator the other will act as a motor—was an important step taken in the transmission of power. Numerous efforts, since then, have been made to utilize electricity for the transmission of power over a long range. For this purpose the alternating current seems eminently adapted. The possibilities offered by electrical transmission of water-power for sections of country favored with waterfalls are numerous, and should result in making them great industrial centres. Already attempts are being made to utilize the immense power now wasting at the Niagara Falls by electrical transmission. From a point above the Falls to a point below, a tunnel through the rock is well under way, and when com-

ELECTRIC LIGHT.

pleted it is expected to develop at least 125,000 horse-power, which is proposed to be carried to Buffalo, N. Y., and other points.

The phrase, '*distribution of electricity*,' has been used during the last few years to denote the supplying of strong currents of electricity from central stations where they are generated, to houses, street lamps, &c., in their vicinity. The central station contains a few powerful dynamo machines, driven usually by steam-power. The positive and negative terminals of the dynamo are put in connection with the positive and negative main conductors which are to supply the district, and from these mains smaller conductors branch off to the houses or lamps. All these conductors are of copper, that metal when pure having seven times the conductivity of iron. Different methods are in use for keeping the supply of electricity steady in spite of the varying demands made upon it. In some systems of distribution, instead of the two main conductors being one positive and the other negative, each is positive and negative alternately, the reversals taking place some hundreds of times per second. The currents are then said to be *alternating*. When such reversals do not take place, the currents are said to be *direct*.

Electric Light, a light obtained through heating a suitable body to incandescence by causing a current of electricity to pass through the body. The substance usually employed for this purpose is carbon, which has two recommendations: first, its power of bearing a very high temperature without melting; and secondly, its high emissive power, which is the source of most of the light in the flame of a candle, an oil lamp, or a jet of gas.

Until quite recent years the only kind of electric light in practical use was what is now called the *arc light*. The arc light is obtained by causing two sticks of carbon, one of them in connection with the positive and the other with the negative terminal of a battery or dynamo, to touch each other for an instant so as to complete the circuit, and then separating them and keeping them steadily at a small distance apart. Before the carbons have touched, the cold air between them prevents the current from passing, but as soon as they touch they become intensely heated, and if they are not separated too far the air between them is hot enough to serve as a conductor. The light is emitted partly by the ends of the carbons,

especially of the positive carbon, and partly by the gaseous matter (containing also fine particles of solid carbon) which occupies the intervening space and forms the *arc* or streak of light joining the two carbon points. When the source of electricity is an alternating-current machine each carbon is alternately positive and negative several times in a second, and the two points behave alike. When the source is a direct-current machine or a galvanic battery the positive carbon wears away about twice as fast as the negative, and the positive carbon becomes hollow at the end, while the negative remains pointed. The hollow in the positive carbon is the brightest part of the whole arrangement; and when a beam of light is to be thrown in some definite direction, care should be taken that this hollow is exposed to view in that direction.

Fig. 1 contains a representation of the two carbons of the arc light as they appear when cold, the positive carbon being marked + and the negative --. Also a magnified representation such as can be obtained by throwing an image of the burning carbons on a screen by means of a lens.



Fig 1.—Arc Light Carbons.

To keep the carbons at the proper distance apart a special contrivance called a 'regulator' is employed. There are many varieties of regulator, but they all depend on the principle that increase of distance between the carbons causes increase of resistance. They usually contain an electromagnet through which either the whole or a portion of the current passes, and the variations in the strength of this magnet arising from change of resistance are taken advantage of to cause the motion, in one direction or the opposite, of a piece of iron which locks and unlocks the mechanism.

As regards the material of the carbon sticks, Sir Humphry Davy used pieces of wood-charcoal, and the substance deposited in the interior of gas retorts has sometimes been employed, but it is now usual to employ a mixture of powdered carbon (from gas retorts), lamp-black, syrup, and gum,

ELECTRIC LIGHT.

with a very little water. The sticks are obtained by forcing this pasty mixture through a draw-plate; they are then baked, and after being again impregnated with syrup are heated to a high temperature.

Arc lights give the largest amount of light for a given amount of horse-power expended in driving the dynamo; but incandescent lights, which have been introduced by Edison, Swan, and other inventors of late years, possess several advantages. Fig. 2 represents Swan's incandescent lamp. A is a glass vessel of globular form exhausted very perfectly of air. BB is a fine elastic filament of carbon, prepared from parchment paper, and becoming incandescent when the current is sent through it. Its two ends are attached to two platinum wires which, where they pass out of the bulb, are hermetically sealed into its wall by fusion of the glass around the wires. These two wires are in connection with the two binding-screws CC when the lamp is upon the stand, where it is held in its place by the spiral wire D.

Owing to the absence of oxygen, there is no combustion in an incandescent lamp, and hence the carbon does not waste away. The want of means to obtain a sufficiently good vacuum was the chief cause which prevented the earlier introduction of such lamps. Sprengel's mercurial pump, with Crookes's improvements, has supplied this want. All the incandescent lamps agree in having a carbon filament suspended *in vacuo*, but they differ in the mode of preparation of the carbons and in other details.

The light of an incandescent lamp is extremely steady, affording a great contrast to the flickering which is never altogether absent from arc lights. Its temperature is lower, and hence its colour is not blue or violet, like that of most arc lights, but slightly yellow, though whiter than gas. It is superior both to gas and to the arc light in giving off no products of combustion to vitiate the air of an apartment.

The Jablochkoff light, which is represented in fig. 3, occupies an intermediate place, but more nearly resembles the arc

lamps. The two sticks of carbon (AA) are side by side at the distance of $\frac{1}{4}$ inch or $\frac{1}{2}$ inch according to the power of the lamp, and this intervening space is occupied either with plaster of paris or china-clay (B). The lower ends of the carbons are inserted in copper or brass tubes (CC) separated by asbestos. The lamp is lighted by temporarily inserting a piece of carbon to connect the ends of the two sticks; and after a fair start has once been obtained, the top of the plaster of paris is hot enough to act as a conductor. Its incandescence contributes a portion of the light of the lamp, and it gradually burns away so as never to project quite so far as the carbons. Alternating currents are now always used with it, as the two carbons may then be exactly alike and will wear away equally.

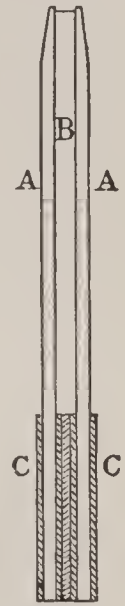

Fig. 3.

The introduction of electric lights for commercial uses may be said to date from the lighting of the Avenue de l'Opéra at Paris by Jablochkoff lamps, a few years previous to the Paris Electrical Exhibition of 1881. The electric light, as previously known, was considered too dazzling for street purposes, but the Jablochkoff 'candles,' which even when naked are far less dazzling than 'arc' lights, were concealed from direct view by opal globes, and instead of single points of dazzling brightness, presented an appearance like a row of full moons. Inventive ingenuity has been largely expended upon the details of electric lighting, as the records of the Patent Office will testify—for cut-outs, arc-lamp regulators, sockets and keys, dynamo regulation, systems of distribution, &c. The generator has attained an unrivalled degree of perfection, almost 95 per cent. of the power obtained being yielded as electric energy. The continuous current-dynamo is now a work of art. The various steps of its construction are operations of peculiar skill. The electric light has been applied to a great many special uses; for instance, in dentistry and surgery the incandescent lamp is used to explore hidden recesses of the human frame, and on ships the arc-lamp as a search light. In submarine work electric lighting has proven of great value. Street lighting with arc-lamps has had an enormous development, and nearly all towns of any progress in the United States have their streets el-

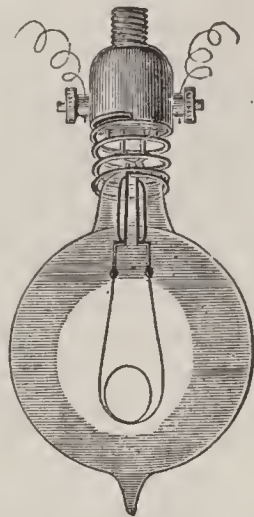

Fig. 2.—The Swan Lamp.

ELECTRIC MACHINE.

trically lighted. The extraordinary development in the application of alternating currents is specially notable. This system of lighting has spread with such rapidity that it is now in general use all over the United States. The meter has received its due share of attention from the unwearying inventor, more than 200 patents, from the United States Patent Office, having been issued for direct and alternating currents.

Electric Machine, any machine for producing powerful electrical effects. The

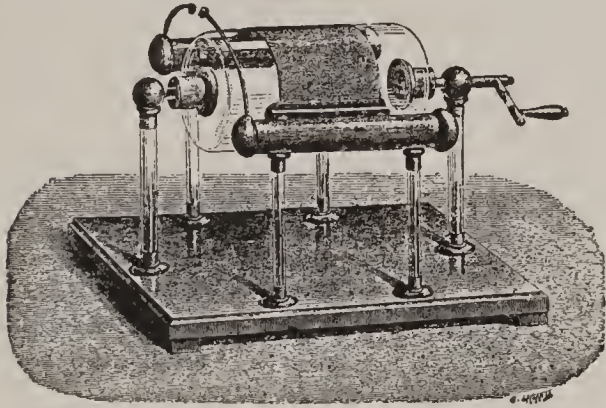

Fig. 1.—Cylinder Electric Machine.

name is, however, seldom applied to machines depending on magneto-electric principles, and is practically confined to two classes of machine—those which act by friction, and those which act by electrostatic induction. The former are called

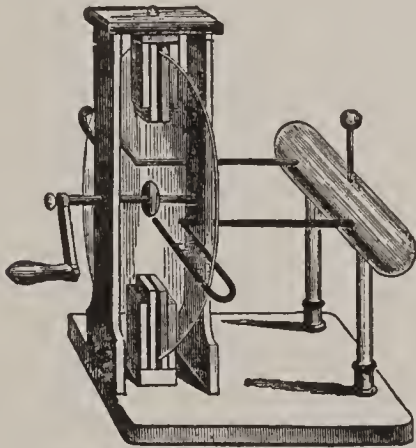

Fig. 2.—Plate Electric Machine.

Friction Machines, and the latter Influence Machines. For many years the former were the only kind known, but they have now been almost superseded by the latter. In friction machines the electricity is generated by the friction of either a glass cylinder or a circular glass plate against cushions covered with an amalgam of zinc and tin. The positive electricity which is thus developed on the surface of the glass is given

off to an insulated brass conductor furnished with teeth like those of a comb, the sharp points of which are nearly in contact with the glass. The negative electricity which is at the same time generated on the cushion must be provided with some means of escaping, or the action of the machine would soon stop. It is usually allowed to escape to the earth by a brass chain connected with the cushions; but in some machines a negative conductor connected with the cushions is insulated like the positive conductor by a glass support. Negative sparks can then be drawn from this conductor at the same time that positive sparks are drawn from the other. A cylinder machine having both a positive and a negative conductor is shown in fig. 1, and a plate machine in fig. 2.

An influence machine (that of Voss) is exhibited in fig. 3. Of the two glass plates which it contains the larger is stationary, and has two patches of tinfoil on its back, one of which has a positive and the other a negative charge. One of them covers the left-hand and upper portion of the back, and the other the right-hand and lower portion. The revolving plate has six metallic studs like that seen at D set in it at equal distances. The sloping bar seen in front of it is of brass and carries two little brushes AA of thin brass wire, against which the studs rub as they pass by, and this happens at the same moment for both brushes. When the studs have advanced about a quarter of a revolution, they come in contact with another pair of brushes BB which are in connection with the two patches of tinfoil, and serve to replenish their charges.

There are also two brass combs fixed opposite the two horizontal radii of the plate, one row collecting positive and the other negative electricity. They are in connection with the two knobs C which are seen in front of the machine, and a brilliant discharge of electricity takes place between these knobs. The first influence machine that came into extensive use was that of Holtz, and the latest (and probably the best) is that of Wimshurst, in which both the plates revolve, their directions of rotation being opposite. The machine of Holtz is started by holding a flat piece of vulcanite, which has been excited by friction, at the back of the fixed plate. The machines of Voss and Wimshurst, if kept dry, will usually work without such assistance, their action being such as to rapidly increase any

casual charge possessed by the plates. For other kinds of machine by which electric

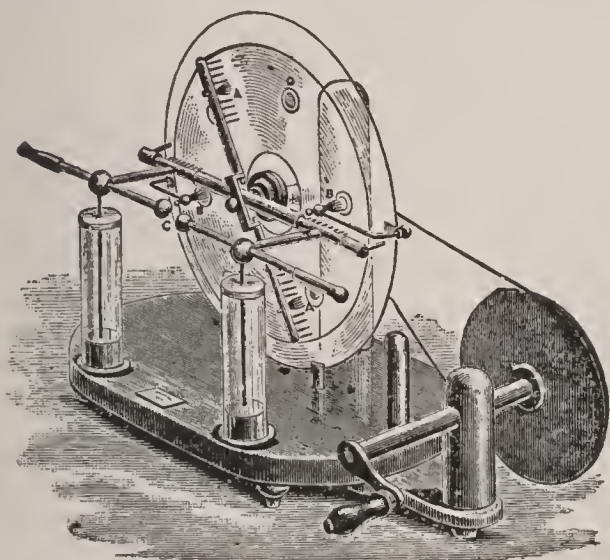

Fig. 3.—Voss's Influence Machine.

shocks can be obtained, see *Electro-medical Machines*.

Electric Railway. The enormous development of the electric railway in the United States can be appreciated from the fact that there are now in operation by electricity at least 450 railways, having over 3000 miles of track and 6500 motor cars, and a capacity of 300,000 horse-power. The electric railroad equipment in the United States represents a value of \$75,000,000. They have spread rapidly through every section, and have shown themselves fully able to handle travel in the busiest city as well as in the rural district. Boston at present has the largest electric railway system, covering 285 miles of track. The overhead system of supply, from its cheapness of equipment and reliability, commends itself most emphatically to operators of street cars. The voltage generally employed is less than 500, and it has been repeatedly shown that from such an electromotive force no danger to human life can result. The underground conduit is perhaps a clever solution of the problem of locomotion by electric power; but trials so far made have not proved the reliability of the system in all changes of weather. The cost of a well-constructed conduit is another drawback. The cities of Denver, Cleveland and Boston have experimented with the system on an extensive scale; but continual interruptions in travel have exhausted patience and the system has been generally abandoned. The storage-battery system has had its advocates; so far invention has been con-

finied to storage batteries with active electrodes of lead, making the cells very heavy, adding immensely to the aggregate weight of the car, and requiring increased energy to propel it. The system has been so far perfected that scarcely two minutes are required to replace exhausted batteries with fresh ones. But the great weight of the batteries confines operations to light grades, and probably a grade of ten per cent. would prevent economical operation. On the G street line, Washington, this system is now in service. In Baltimore the electric motor is used by the B. & O. R. R. in the Belt Line tunnel for hauling of trains.

Electrocution, a wretchedly bad term for execution by electricity.

Electro-dynamometer, an instrument used for the measurement of electric currents by means of the mechanical forces which they exert upon each other. It contains two coils of wire, one fixed and the other movable; the latter being either larger or smaller than the other so as to be able to pass either outside it or through it. Both coils are in vertical planes and have the same vertical diameter, round which the movable one can revolve so as to set its own plane at any angle with the plane of the other. The terminals of the movable coil dip in cups of mercury, one of which is in connection with one end of the fixed coil, and the other with one of the binding-screws of the instrument. The other binding-screw is in connection with the other end of the fixed coil. Hence when the two binding-screws are connected with a battery or other source of electricity, the current has to pass through both coils. Its effect is exhibited by a tendency in the movable coil to set its plane in coincidence with that of the fixed coil, and in such a manner that the current will circulate the same way round both coils. This tendency is resisted by mechanical means provided for the purpose—usually by the torsion of a wire from the end of which the movable coil hangs; and the measurement is usually made by applying torsion until the planes of the two coils are at right angles. The amount of torsion thus applied is proportional to the mutual force exerted by the two coils.

Electrolysis (Greek, *lysis*, loosening) is the chemical decomposition of certain compound bodies under the action of a current of electricity. The following are the main facts to be mentioned. When an *electrolyte* (as a body capable of electrolytic decompo-

sition is called) is subjected to a current of electricity of sufficient intensity, it is broken up into two elements, which appear, one of them at one electrode and the other at the other electrode; thus, if two platinum plates connected with the first and last plates of a battery be plunged in a trough containing a solution of chloride of silver, the chlorine is given off at the plate by which positive electricity enters, that is, at the plate which is connected with the copper plate of the battery, and the silver is deposited at the plate connected with the zinc plate of the battery. The two elements are liberated at these places in quantities chemically equivalent. Thus for every 108 grammes of silver deposited at one side of the vessel 35.5 grammes of chlorine are given off at the other side. When a compound consisting of a metallic and a non-metallic part is decomposed, the non-metallic part is set free at the electrode at which the current enters and the metallic part at the opposite electrode. Hydrogen acts as a metal. Electrolysis takes place only when the electrolyte is in a liquid state, and involves a transfer of the materials of which the compound is composed from one part of the vessel to another. (See *Electrode, Electro-metallurgy.*)

The electrolytic action of the current is the same at all parts of the circuit. If the current is made to traverse several vessels, each containing the same substance, all in *series* (that is, the current that leaves the first entering the second, and so on), it will be found that in each of the cells precisely the same amount of decomposition goes on. There will be the same weight of silver deposited at one side, and the same weight of chlorine set free at the other.

The same quantity of electricity decomposes chemically equivalent quantities of different electrolytes. If we pass the current through a series of cells containing different electrolytes, for example, water, chloride of silver, sulphate of soda, and collect the products of decomposition, we find that the quantities of hydrogen, silver, and sodium set free are strictly proportional to the chemical equivalents of these bodies. Further, in the battery which gives rise to the electric current, if precautions are taken to avoid disturbance by local action on the plates, it is found that the action which goes on in each of its cells is chemically equivalent to that in each of the decomposing cells.

The quantity of the electrolyte decomposed

in a given time is proportional to the strength of the current. Currents are often measured in practice by observing the weight of copper deposited in a given time from a solution of sulphate of copper.

Electrolyte. See previous article.

Electro-magnet, a piece of iron temporarily converted into a magnet by means of a current of electricity sent through a wire which is coiled round it. The wire is usually covered with silk, cotton, gutta percha, or some other insulator, to prevent the current from leaping across, and compel it to travel through the whole length of the wire. The more pure and soft the iron is, the stronger will its magnetism be while it lasts, and the more completely will it disappear when the current stops. Steel is less affected than soft iron for the time, but remains permanently magnetized after the current ceases. Electro-magnets are usually much more powerful than other magnets of the same size. The iron which is magnetized by the current passing round it is called the *core*. It is frequently straight, the wire being wound upon it like thread upon a reel; but very frequently it has the shape of a U, or horse-shoe, the wire being coiled round the two ends and the bend of the U left uncovered.

To predict which end will be the north pole, the following rule may be employed: Let the core be a straight bar of iron held in front of you pointing left and right, then if the current ascends on the side next you, and descends on the further side, the north pole is to your left hand and the south pole to your right. If the straight bar is then bent into horse-shoe shape, its poles will not be changed. There is no necessity to inquire whether the wire forms a right-handed or a left-handed helix, this circumstance having no influence on the question of poles. Indeed, in most cases (just as in the case of thread on a reel) the helices are some right-handed and some left-handed.

An electro-magnet is said to be *made* when the current is sent through its coil, and *unmade* when the current is stopped. In some applications of electro-magnets it is necessary to make and unmake them in rapid succession. It is then preferable for the core to consist of a bundle of iron wires rather than of a solid bar.

Electro-magnetism, a term that in its broadest sense denotes the science which treats of the relations between magnetism and electricity. In a narrower sense a

magnetic effect produced by electricity is said to be *electro-magnetic*, while an electrical effect produced by the agency of magnets is called *magneto-electric*. In the preceding article we have described one electro-magnetic effect—the making of an electro-magnet by means of a current. Another important electro-magnetic effect is the deflection of a magnetic needle by a current of electricity passing near it. The simplest experiment to illustrate this action is to take an ordinary mariner's compass, hold just above it a copper wire parallel to the needle of the compass, and then, while the wire is in this position, let its two ends be connected with the two poles of a galvanic battery. The needle will instantly turn away from its north-and-south position, and will remain deflected as long as the current continues to pass over it. If the current flows from south to north, the north end of the needle is turned to the west; and if the current is in the opposite direction, the needle turns the other way. This is the easiest test for determining the direction in which a current is flowing through a wire; and it is the basis of the construction of *galvanometers*, which are the instruments chiefly employed for the measurement of currents. The current tends to make the needle take a position at right angles to the direction of the current; but as the earth tends to make the needle point north and south, the position actually taken is between the two. The fact that a current deflects a needle was discovered by Ørsted of Copenhagen, and the general rule for the direction of the deflection was thrown into the following form by Ampère: *Imagine the current to enter at your feet and come out at your head, then the north pole of a needle in front of you will be deflected to your left.* This rule holds good whether the current is above the needle, below it, or in any other position. The rule may also be put in the following form: Imagine an ordinary screw placed so that the current is in its axis; the north pole of the needle will turn to the same side to which that part of the circumference which is next it turns when the screw advances in the direction of the current.

The leading fact of *magneto-electricity* is that when a magnet is moved in the neighbourhood of a wire or other conductor, the motion causes a current of electricity in the conductor; and a similar effect occurs if the wire is moved while the magnet remains at

rest. In the experiment, above described, of making a magnetic needle turn on its pivot by sending a current through a wire held above it, the motion of the needle produces for the time being a weakening of the current. If the needle were made by mechanical means to turn the contrary way, it would strengthen the current for the time being. If there were no original current, the turning of the needle to either side by mechanical means would produce a current in the wire. The current thus produced is always opposite in direction to that which would aid the motion.

Electro-medical Machines, machines intended for giving shocks for medical purposes. They are of various kinds, but they all produce their effects by a rapid succession of either interruptions or reversals of an electric current. Such interruptions or reversals are always accompanied by the action called *self-induction*, especially when the original current flows through a coil of many convolutions, and still more if these convolutions encircle an iron core. Self-induction in such

cases shows itself as a sudden and violent action, having the same sort of relation to a steady current that a blow has to a steady pressure. One form of electro-medical machine is shown above. At the top of the figure are shown two small galvanic cells, in which for greater portability materials of pasty consistency are used instead of liquids. The bottle shown below is for replenishing them. In the centre of the figure are seen two cylindrical coils, through which the current from the two cells passes. They have cores of soft iron to strengthen their action, and they have also sliding covers of copper for mitigating their action. These are shown in the figure as pulled out a short distance, so as to uncover a small portion of the coils. The shocks become stronger as these covers

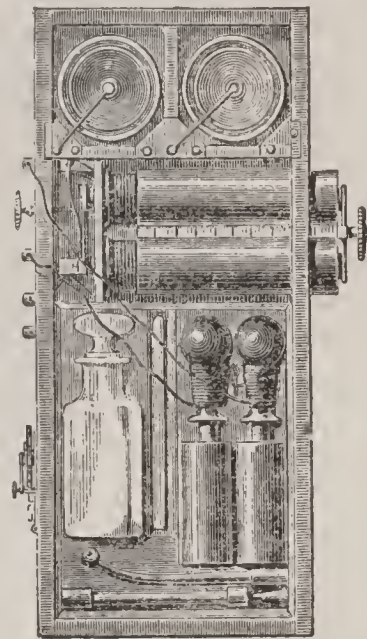

Electro-medical Machine.

are drawn further out. The action of the covers may be described as a muffling or cushioning of the sudden violence of self-induction. Some of the commonest forms of electro-medical machine are magneto-electric, their currents being produced by making a coil of copper wire rotate rapidly between the poles of a strong magnet. The employment of such a machine for administering shocks to patients is called *faradisation*, from Faraday, the discoverer of magneto-electricity.

Electro-metal'lurgy, the art of depositing metals from solutions of their salts upon metallic or other conducting surfaces by the agency of an electric current. Its operations may be classified under three heads: the making of facsimiles, the formation of permanent coatings, and the obtaining of a pure metal from an impure. In every instance the current enters the solution by a plate of the metal in question, which is immersed in it, and leaves the solution by the conducting surface on which the deposit is formed. The plate at which the current enters (called the *anode*) is gradually dissolved, and an equal quantity of the metal is at the same time deposited on the surface by which the current leaves the solution (called the *cathode*). The source employed for giving the current was formerly a galvanic battery, but is now more frequently a dynamo machine, in which the armature is constructed of much stouter wire than is used in dynamos intended for other purposes. Copper lends itself with special readiness to electrical deposition, and the solution employed for the purpose is usually a saturated solution of sulphate of copper; but if the surface to be coated is of iron, steel, or zinc, it is necessary to employ an alkaline solution, in which cyanide of potassium and carbonate of soda are usually the chief ingredients, a salt of copper being present in comparatively small quantity. For electro-gilding, a solution containing cyanide of potassium and cyanide of gold is employed; and for electro-plating, a solution of cyanide of potassium and cyanide of silver. It so happens that the impurities which usually occur in copper roughly smelted from the ore consist of substances which either cannot be dissolved in a solution of sulphate of copper, or cannot be deposited on a copper surface from such a solution. Hence when a plate of crude copper is used as the anode, pure copper is deposited on the cathode, and most of the

impurities fall to the bottom of the vessel. Pure copper is now produced in enormous quantities by this method, purity being an essential requisite in copper wire for electrical purposes.

The most important instance of the deposition of a permanent coating is electro-plating. To ensure good adhesion it is necessary to remove every particle of grease and oxide from the surface (usually German silver) on which the silver is to be deposited. With this view the article to be plated, after being well scoured, is boiled in a strong ley of caustic potash or soda, and dipped in dilute acid, technically called *pickle*; after which it is washed in distilled water, and then quickly dipped in a solution of nitrate of mercury until it appears white on the surface. Finally it is suspended in the silver solution, when it is immediately coated with a thin film of silver. This operation is called *striking*. After a few seconds it is taken out and well brushed, generally with bundles of brass wire attached to a lathe; it is then washed and replaced in the plating solution, where it is allowed to remain for a longer or shorter period according to the thickness of deposit required. An immersion of a few hours is generally sufficient. To ascertain the amount of metal deposited it is only necessary to weigh the articles from time to time. One and a quarter or one and a half ounce of silver to the square foot gives an excellent plate about the thickness of common writing-paper. In ordinary circumstances the coating of deposited silver is chalk-white, and has a dead or matted appearance, which is much esteemed for medals. Sometimes the operator is desirous of having his object bright, either entirely or partially. In this case the object is brushed over with old beer or dipped into a solution of soft soap, and is then submitted to the burnisher. Certain chemicals added to the solution will cause the original deposit to have a metallic lustre.

The production of copper facsimiles by the electric current is called *electrotype*, and is the oldest branch of electro-metallurgy. One of its most important applications is the copying of type set up for printing, and of wood blocks for wood-cuts. A mould is first obtained in gutta percha or some similar material. This, being a non-conductor, is brushed over with plumbago in its interior, so as to give it a conducting surface to receive the deposit. After several hours the deposit is detached from the mould and

backed by pouring in melted solder, the surface being first moistened with chloride of zinc to make the solder adhere. In the copying of steel engravings the mould is obtained by electro-deposition of copper on the steel, the surface of which must first be specially prepared to prevent adhesion; and a second electro-deposition of copper, on the mould thus obtained, gives the required copy, from which impressions can be printed.

Electrom'eter, an instrument intended for accurate electro-static measurements. Stated in precise technical language, its purpose is to measure the *difference of potential* between two conductors. Most of the electrometers in actual use are inventions of Sir William Thomson, who was the first to give accuracy to this branch of electrical measurement. His quadrant-electrometer is the instrument chiefly used, and its indications are usually given by means of a small movable mirror which reflects a spot of light from a lamp on to a paper scale. When the two conductors which are tested have the same *potential* the spot of light stands in the middle of the scale, and its movement to either side indicates the difference of their potentials. The instrument is sufficiently delicate to give a sensible displacement when the two conductors are the two plates of a single galvanic cell; and a displacement twice as great will be obtained by combining two such cells.

Electro-motive Force, a phrase (commonly abbreviated into the three initial letters e.m.f.) which is of very frequent use in modern electrical literature, especially in connection with electric currents. The e.m.f. in a wire through which a current is flowing may be compared to the difference of pressures in a long, narrow, horizontal pipe, through which water is flowing. As the difference of the pressure at the two ends of the pipe forces the water through in spite of frictional resistance, so the difference of the *potentials* at the two ends of the wire forces the current through in spite of the electrical resistance of the wire. This *difference of potentials* is another name for *electro-motive force*. Each cell of a battery is a source of e.m.f., and when the cells are connected in the usual way (technically called *in series*) their e.m.f.'s are added together, so that, for example, the e.m.f. of a battery of ten cells is ten times the e.m.f. of one cell. E.m.f. can also be produced in a wire by moving a magnet in its neighbour-

hood, and this e.m.f. will be exactly proportional (other things being equal) to the velocity of the motion. The commercial unit of e.m.f. is the *volt*. Its magnitude may be inferred from the statement that the e.m.f. of a single cell is usually more than one volt, and less than $2\frac{1}{2}$ volts. The highest e.m.f. permitted by the Board of Trade in wires which are liable to be touched by the public is about 200 volts. It is no unusual thing for a dynamo to give an e.m.f. of 1000 or 2000 volts. Currents produced by a source of high e.m.f. are often called *currents of high tension*. They are necessary when several arc lamps are to be supplied in series, and they are also necessary (on the score of economy) when power is to be transmitted by electricity to great distances.

Electro-motors, or ELECTRO-MAGNETIC ENGINES, are contrivances for making a current produce continuous rotatory motion, the force producing the motion being sufficient to overcome a considerable amount of mechanical resistance, and so do useful work. Until quite recent years this object was effected by the alternate making and unmaking of electro-magnets, which attracted pieces of iron provided for the purpose, and caused them to move in the directions required for producing continuous rotation. In modern electro-motors the action is greatly intensified by employing, instead of the above-mentioned pieces of iron, electro-magnets whose poles are alternately attracted and repelled by those of the fixed electro-magnets. In order to produce these alternate attractions and repulsions the currents in the moving electro-magnets are continually reversed, while the currents in the fixed magnets are always in the same direction. The revolving electro-magnet or group of electro-magnets is called the *armature*. It revolves with great rapidity, and its movement is transmitted by a belt or otherwise to the machinery which is to be driven. The construction of an electro-motor is almost precisely similar to that of a direct-current dynamo. Indeed the same machines have often been used interchangeably for both purposes. See *Electric Railway, Electricity*.

Electroph'orus, an electrical instrument consisting of two plates, the lower of vulcanite or shellac, with tinfoil or other metal at the bottom, and the upper of brass, with a glass handle. The operator begins by applying friction with a catskin or flannel to

the upper surface of the lower plate, which thus acquires a negative charge. The upper plate is then placed upon it and pressed closely down. In this process the upper plate, being in connection with the earth through the body of the operator, acquires a positive charge by induction; and if the upper plate be now lifted off by its glass handle, a good spark can be obtained from it. It may then be pressed down again, removed again, and another spark obtained, and so on, time after time. If the insulation is thoroughly good, hundreds of sparks can be drawn in this way without the necessity of renewing the charge on the surface of the lower plate. It might have been expected that the upper plate would require a coating of insulating varnish to prevent it from touching the lower one; but experience shows that this precaution is unnecessary. A smooth plate of metal does not easily receive electricity from an insulating substance with which it is brought in contact. The electrophorus is often so constructed that when the two plates are in contact, the upper plate is in conducting communication with the metal base of the lower plate. This arrangement saves time, as it is then unnecessary to touch the upper plate with the hand.

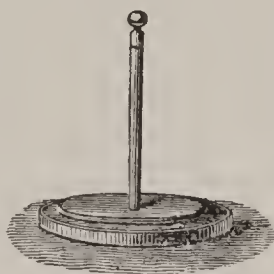

Electrophorus.

Electroplate. See *Electro-metallurgy*.

Electroscope, any apparatus for showing the presence of electricity without giving quantitative measurements. One form consists of two stiff straws loosely tied together at the top, so that they are free to open out at the bottom whenever they repel each other. If they are placed in conducting communication with an electrified body they will open out. A more sensitive instrument is the gold-leaf electroscope, which is represented in the adjoining figure. Here the two gold leaves are shown diverging under the influence of an electrified body held over the instrument. The gold leaves are attached to the lower end of a short rod of brass, whose upper end carries the brass knob which forms the top of the instrument. These metal parts are supported by the glass shade which insulates them from the earth, and the upper part of which is represented in the figure as coated with varnish, but this is not essential. The two gold leaves originally hang down parallel, and nearly touch-

ing each other. When an electrified body is slowly brought down over the knob from a good height above it, the unlike electricity is attracted to the knob, and the like electricity is repelled into the gold leaves, which, in consequence of being thus electrified, repel each other. The two little brass columns standing up from the base are in connection with the earth, and their presence increases the divergence of the leaves. As soon as the electrified body above is removed, the leaves come together again. If, however, while the leaves are standing apart under the influence of the body overhead, the knob is touched with the finger, the leaves will instantly come together. It will then be found that either lowering or raising the influencing body causes them to open out again; and if the influencing body is removed they will open out to the same width at which they stood just before the knob was touched. The leaves and

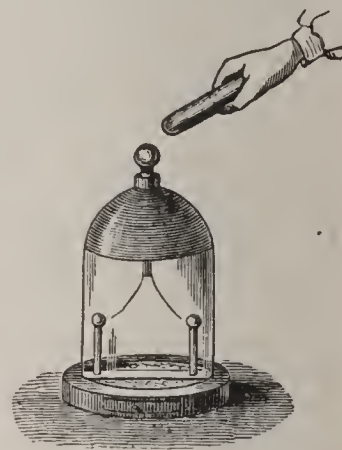

Gold-leaf Electroscope

knob have now a charge opposite to that of the influencing body, and the electroscope can now be used to show whether the charge of a second influencing body is positive or negative. If the second body has the same kind of electricity as the first, it will diminish the repulsion; if it has the opposite kind, it will increase the repulsion.

Electrotype, that branch of electro-metallurgy which deals with the production of facsimiles. See *Electro-metallurgy*.

Electrum (Gr. *ēlektron*), in antiquity, a term applied originally to native gold, which frequently contains notable quantities of silver, copper, and other metals; hence latterly it was transferred from this native alloy to the artificial alloy of gold and silver, and was also applied to amber on account of its colour and inferior lustre.

Electuary, the name given to medical preparations of a pasty consistency, made by thoroughly mixing some kind of fine powder with syrup, honey, or sugar, for internal use.

Eligit, in English law, a writ by which a creditor who has obtained a judgment against a debtor, and is hence called the

judgment-creditor, may be put in possession of the lands and tenements of the person against whom the judgment is obtained, called the *judgment-debtor*, until the debt is fully paid. The writ is addressed to the sheriff. It is still in use in the U. States.

El'egy (Gr. *elegos*), a mournful and plaintive poem or funeral song, or any serious poem of a melancholy contemplative kind. In classic poetry what is known as *elegiac verse* is composed of couplets consisting of alternate hexameter and pentameter lines.

Element'al Spirits, according to a belief common in the middle ages, spirits proper to and partaking of the four so-called elements, viz. salamanders or fire spirits, sylphs or aerial spirits, gnomes or earth spirits, and undines or water spirits.

Elementary Education. See *Education*.

El'ements, the simplest constituent principles or parts of anything; in a special sense, the ultimate indecomposable constituents of any kind of matter. In ancient philosophies the term was applied to fire, air, earth, and water. The mediæval chemists, however, absorbed in the study of metals and mineral substances, supposed that the metals consisted of an elemental sulphur and an elemental mercury mixed together more or less perfectly and in different proportions. To these were subsequently added salt and some others, so that about the middle of the 17th century the first principles amounted to five, divided into two classes: the active, consisting of mercury or spirit, sulphur or oil, and salt; and the passive, consisting of water or phlegm, and earth or the terrestrial part. The names remained, not so much as denoting substances or ultimate principles as gradually coming to denote functions; the first great modification being the expansion of the idea of elemental sulphur into phlogiston by Stahl, as the result of which the adherents of the phlogistic theory applied the term to phlogiston, to the gases then discovered, the mineral, vegetable, and animal acids, the alkalies, earths, and metallic calces, oil, alcohol, and water. The substances considered as simple naturally changed with the change of theory introduced by Lavoisier, who considered as elements, oxygen, nitrogen, hydrogen, sulphur, phosphorus, and carbon, the metals and the earths, and, as Boyle had already suggested, practically defined an element as a body not yet decomposed, the definition now commonly adopted. For list of known elements see *Chemistry*.

El'emi, the resinous exudation from various trees, such as the *Canarium commūne*, from which the Eastern or Manilla elemi is obtained; the *Icica Icicariba*, the source of the American or Brazilian elemi; and the *Elaphrium elemifērum*, from which the Mexican elemi comes. It is a regular constituent of spirit varnishes, and is used in medicine, mixed with simple ointment, as a plaster.

El'ephant, the popular name of a genus or sub-family of five-toed proboscidian mam-

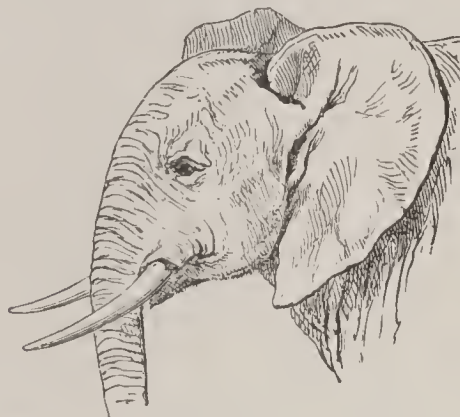

Head of African Elephant (*Elephas africanus*).

mals, usually regarded as comprehending two species, the Asiatic (*Elephas indicus*) and the African (*E. africanus*). From a difference in the teeth, however, the African species is sometimes treated as a distinct



Head of Indian Elephant (*Elephas indicus*).

genus (*Loxodon*), and some authors divide the Asiatic elephants into several species, such as the Indian elephant (*Elephas indicus*), the Ceylon elephant (*E. cingalensis*), and the Sumatra elephant (*E. sumatrānus*). The so-called white elephants are merely albinos. The African elephant is distinguished from the Asiatic species by its greater height, its larger ears, its less elevated head and bulging or convex forehead, the closer approximation of the roots of the

tusks, and the greater density of the bone. It has also only three external hoofs on the hind-feet, while the Asiatic has four. All elephants are remarkable for their large, heavy, short bodies supported on columnar limbs, a very short neck, a skull with lofty crown and short face-bones, with the exception of the premaxillaries, which are enlarged to form tusk-sockets. To compensate for the short neck, they have the long proboscis, often 4 or 5 feet in length, produced by the union and development of the nose and upper lip. It is made up of muscular and membranous tissue, the only cartilages being the valves at the entrance of the nares. The trunk is of great strength and sensibility, and serves alike for respiration, smell, taste, suction, touch, and prehension. The tusks, which are enormously developed upper incisor teeth, are not visible in young animals, but in a state of inaturity they project, in some instances 7 or 8 feet. The largest on record (possibly that of an extinct species) weighed 350 lbs. Elephants sometimes attain the height of 15 feet, but their general height is about 9 or 10. Their weight ranges from 4000 to 9000 lbs. The female is gravid twenty months, and seldom produces more than one at a birth: this, when first born, is about 3 feet high, and continues to grow till it is sixteen or eighteen years of age. It is said they live to the age of 100 years and upwards. They feed on vegetables, the young shoots of trees, grain, and fruit. They are polygamous, associating in herds of a considerable size under the guidance of a single leader. An elephant leaving or driven from a herd is not allowed to join another, but leads a solitary, morose, and destructive life. These are popularly known as 'rogues.' Elephants are caught either singly or in herds. In the former case it is necessary to catch adroitly one of the elephant's legs in the noose of a strong rope, which is then quickly attached to a tree; another leg is then caught until all are securely fastened. His captors then encamp beside him, until under their treatment he becomes tractable. When a number are to be caught a strong inclosure is constructed, and into this the elephants are gradually driven by fires, noise, &c. With the aid of tame elephants the wild ones are tied to trees and subjected to the taming process. The domesticated elephant requires much care, and a plentiful supply of food, being liable to many ailments. The daily consumption of a work-

ing elephant is, according to Sir J. E. Tennent, 2 cwts. of green food, about half a bushel of grain, and about 40 gallons of water. Their enormous strength, docility, and sagacity make them of great value in the East for road-making, building and transport. They are used by the great on occasions of pomp and show, being often richly caparisoned, and bearing on their back a howdah containing one or more riders, besides the mahout or driver sitting on the animal's neck. Tiger-shooting is often practised from an elephant's back. The fossil remains of the genus *Elephas* indicate the former existence of at least fourteen species; and a still larger number of species belong to the allied genus *Mastodon*.

Elephant, ORDER OF THE, an ancient Danish order of chivalry, said to have been instituted about the end of the 12th century by Canute VI. to perpetuate the memory of a Danish Crusader who had killed an elephant in the Holy Land. It was renewed by Christian I. in 1462, in 1693 by Christian V., and again in 1808. It is the highest of the Danish orders. The number of members, not counting those of the royal family, is restricted to thirty. The badge of the order is an enamelled white elephant, bearing on a blue housing, bordered with gold and crossed with white, a sculptured tower. The device is *Magni animi pretium*.

Elephan'ta, a small island in the Bay of Bombay, between Bombay and the mainland, 7 miles north-east of the former; circumference about 5 miles. It consists of two long hills chiefly overgrown with wood. It has a few inhabitants, who rear sheep and poultry for the Bombay market. It is celebrated for its rock temples or caves, the chief of which is a cave-temple supposed by Mr. Fergusson to belong to the 10th century, 130 ft. long, 123 broad, and 18 high, supported by pillars cut out in the rock, and containing a colossal figure of the trimurti or Hindu trinity Brahma, Vishnu, and Siva. This temple is still used at certain Hindu festivals.

Elephant-apple, an East Indian tree (*Feronia Elephantum*) producing an edible fruit not unlike an orange, and belonging to the same natural order, Aurantiaceæ.

Elephant Bay, an excellent anchorage on the coast of Benguela, S. W. Africa.

Elephant-beetle, the Goliath-beetle.

Elephant-fish (*Callorhynchus antarcticus*), a fish of the order Elasmobranchii

(rays and sharks), so named from a proboscis-like structure on the nose: called also southern chimæra. It inhabits the Antarctic seas, and is palatable eating.

Elephant-grass (*Typha elephantina*), a large kind of bulrush growing in India.

Elephanti'asis, a disease chiefly occurring in tropical climates, characterized by a peculiar overgrowth of the skin and subjacent textures, and attacking especially the legs, which become enlarged and elephantine. It appears to arise from repeated inflammation of the skin and a concurrent obstruction of the veins and lymphatic glands of the inflamed part. The disease occasionally affects the scrotum, enlarging it to enormous dimensions. In general it is attended with little pain, and the health may remain otherwise unaffected for many years. In the early stages wet bandaging or ligature of the main artery has been found serviceable, but amputation may be necessary.

Elephanti'ne, a small island of Egypt, in the Nile, opposite Assouan (Syene). It is covered with ruins piled upon each other — Egyptian, Roman, Saracen, and Arabic, the most important being a gateway of the time of Alexander, a small temple dedicated to Khnum and founded by Amenophis III., and the ancient Nilometer mentioned by Strabo. The island gave the fifth dynasty to Egypt.

Elephant River, a river of Cape Colony, running into the Atlantic after a course of 140 miles.

Elephant-seal, the Proboscis Seal, or Sea-elephant, the largest of the seal family (Phocidæ). There are probably two species, one (*Macrorhinus angustirostris*) found only on the coast of California and Western Mexico, the other (*Macrorhinus leoninus*) found in Patagonia, Kerguelen Island, Heard's Island, and other parts of the Southern Seas. They vary in length from 12 to 30 ft., and in girth at the chest from 8 to 18 ft. The proboscis of the male is about 15 inches long when the creature is at rest, but elongates under excitement. The females have no proboscis, and are considerably smaller than the male. Both species are becoming rare from their continual slaughter.

Elephant's-ear, a name sometimes given to plants of the genus *Begonia*.

Elephant's-foot, the popular name of *Tes-tudinaria elephantipes*, a plant of the natural order Dioscoreaceæ (yams, &c.), distinguished by the shape of its root-stock, which forms

a nearly hemispherical mass rising a little above the ground, covered with a thick corky bark. It has a slender climbing stem growing to a length of 30 or 40 ft., with small heart-shaped leaves and greenish-yellow flowers. It is known in the Cape Colony as Hottentots' Bread. Some botanists still class it with the very similar species of the genus *Tamus*.

Elephant's-tusk Shell, a name given to shells of the genus *Dentalium* (which see).

Eleusi'ne, a genus of grasses, several of which are cultivated as grain plants in India, Japan, Tibet, &c.

Eleusinian Mysteries, the sacred rites anciently observed in Greece at the annual festival of Dēmētēr or Ceres, so named from their original seat Eleusis. As a preparation for the greater mysteries celebrated at Athens and Eleusis, lesser Eleusinia were celebrated at Agræ on the Ilissus. The greater Eleusinia were celebrated in the month Boedromion (September — October), beginning on the 15th of the month and lasting nine days. The celebrations, which were varied each day, consisted in processions between Athens and Eleusis, torch-bearing and mystic ceremonies attended with oaths of secrecy. They appear to have symbolized the old conceptions of death and reproduction, and to have been allied to the orgiastic worship of Dionysus (Bacchus). They are supposed to have continued down to the time of Theodosius I.

Eleu'sis, in ancient geography, a small city of Attica, about 14 miles from Athens, near the shore opposite the island of Salamis. Its temple of Dēmētēr was one of the most beautiful buildings of Greece. (See *Eleusinian Mysteries*.) There is now a large straggling village here.

Eleu'thera, one of the largest of the Bahama Islands. It is of very irregular shape, its length being about 70 miles, and its breadth in general from 2 to 4 miles, though in one part 10. Pop. over 5000.

Eleuthe'ria Bark, a name for cascarilla bark.

Elevation, in architecture, a geometrical delineation of the front or any face of a building in which all the parts are drawn according to scale, and not shown as they would appear in perspective. — In astronomy, it is the height of a celestial object above the horizon.

Elevation of the Host, in the ritual of the Mass, is the lifting up of the elements immediately after consecration, to be wor-

shipped by the people. It was introduced into the Latin Church in the 11th century, in consequence of the denial by Berengarius of the real presence in the sacrament. The Council of Trent ordered that the host should be worshipped with the highest adoration, that of *latría*, which is offered to God only.

El'evator, (1) a mechanical contrivance consisting of a series of boxes or buckets attached to a belt travelling round two drums, one above and one below, for hoisting grain, meal, &c., into a mill or storehouse from a ship's hold, &c. In America large buildings containing such contrivances, and in which grain is stored, receive the same name. (2) An apparatus for raising or lowering persons or goods to or from different levels in warehouses, hotels, &c., consisting usually of a cage or movable platform worked by hydraulic power: also called a *lift* or *hoist*.

Elf. See *Fairy*.

Elf-arrows, **ELF-BOLTS**, **ELF-SHOT**, popular names in Britain for stone arrow-heads, and other similar ancient barbarian weapons. They are superstitiously worn as charms against lightning; cattle and men are said to have been struck and wounded by them; and they are said to appear in great quantities where the day before there were none.

Elgin (el'gin), a royal and parliamentary burgh of Scotland, capital of Elgin county, finely situated on the Lossie, about 5 miles from its influx into the Moray Firth, 70 miles N.W. of Aberdeen. The town largely consists of mansions and villas. The most interesting edifice is the cathedral, now in ruins, which was once the most magnificent in Scotland. It was founded in 1224; plundered and burned in 1390 by the 'Wolf of Badenoch,' and again in 1402 by Alexander, third son of the Lord of the Isles; restored 1390 to 1424; and again plundered in 1568. Elgin unites with Cullen, Banff, Peterhead, Kintore, and Inverurie (the Elgin burghs) in sending a member to the House of Commons. Pop. 7533.—The county of **ELGIN**, also called Morayshire, is a maritime county, bounded by the Moray Firth, Banffshire, Inverness-shire, and Nairnshire; area, 340,000 acres. Along the sea-coast, which extends for more than 30 miles, the surface is flat, but inland it rises into hills of moderate elevation, intersected by fine and fertile valleys. The chief rivers are the Spey, Lossie, and Findhorn, the Spey and Findhorn having excellent salmon fishing. Inexhaustible quarries of freestone (rich in

fossils) are worked. The climate is noted for its general mildness, dryness, and salubrity. The lower tracts of land are fertile and highly cultivated, the principal crops being wheat, oats, potatoes, and turnips. The great majority of farms are small. A portion of the surface is still covered with native forests. The county unites with Nairnshire in returning one member to the House of Commons. Pop. 1891, 43,448.

Elgin, a town of the U. States, in Illinois, on Fox River, 36 miles N.W. of Chicago. It has a watch-factory and various flourishing industries. Pop. 1890, 17,823.

Elgin, **JAMES BRUCE**, **EIGHTH EARL OF**, and twelfth Earl of Kincardine, Governor-general of India, born in 1811; educated at Eton and Christ Church; entered parliament in 1841 as member for Southampton, and in the same year succeeded to the earldom. He was appointed Governor-general of Jamaica in 1842, and in 1846 Governor-general of Canada. In 1849 he was raised to the British peerage as Baron Elgin of Elgin. In 1857 he went as special ambassador to China, and was successful in concluding the Treaty of Tientsin early in 1858. In 1859 he became postmaster-general in Palmerston's cabinet, but in the following year was sent on a special mission to Peking, and afterwards appointed to succeed Canning as Governor-general of India. He died in 1863 while inspecting the Himalayan passes.

Elgin Marbles, the splendid collection of antique sculptures brought chiefly from the Parthenon of Athens to England by the seventh Earl of Elgin (1766–1841) in 1814, and afterwards purchased by parliament for the British Museum at a cost of £35,000 (less than half what had been expended on them). They consist of figures in low and high relief and in the round, representing gods, goddesses, and heroes; the combats of the Centaurs and Lapithæ; the Panathenaic procession, &c. They exhibit Greek sculpture at its highest stage, and were partly the work of Phidias.

El Hasa, a fertile district of Eastern Arabia, on the Persian Gulf. It produces dates, wheat, millet, rice, &c. Pop. estimated at 160,000.

Eli, one of the Hebrew judges, the predecessor of Samuel. He was high-priest and judge for forty years, but was less successful as head of his own household. His two sons having been slain and the ark taken in battle by the Philistines, the news

proved so severe a shock that he fell and broke his neck, at the age of ninety-eight.

El'as. See ELIJAH.

Elias, MOUNT ST., the culminating point of North America (or surpassed only by Mt. Wrangel), near the line of demarkation between the British territory and Alaska, but a little within the former; height, 19,500 feet.

Eli'jah, the most distinguished of the prophets of Israel, flourished in the 9th century B.C., during the reigns of Ahab and Ahaziah, and until the beginning of the reign of Jehoram, his special function being to denounce vengeance on the kings of Israel for their apostasy. He incurred the anger of Jezebel, wife of Ahab, for slaying the prophets of Baal, but escaped to Horeb, afterwards returning to Samaria to denounce Ahab for the murder of Naboth. Elijah at length ascended to heaven in a chariot of fire, Elisha, his successor, being witness. See 1 Kings xvii. to xxi. and 2 Kings i. and ii.

El'iot, GEORGE, the assumed literary name of Mary Ann, or, as she preferred to write the name in later years, Marian Evans. English novelist. She was the daughter of a Warwickshire land-agent and surveyor, and was born at Griff, near Nuneaton, on 22d November, 1820. She received at Coventry an excellent education, comprising the classical and modern languages, and shortly after her twenty-first year became a convert to Rationalism. Her first literary undertaking was the completion of Mrs. Hennell's translation of Strauss's *Life of Jesus* (1846). After spending two years abroad she boarded at the house of John Chapman, editor of the *Westminster Review*, of which she became sub-editor. It was not, however, until January, 1857, that she came prominently into public notice, when the first of a series of tales entitled *Scenes from Clerical Life* appeared in *Blackwood's Magazine*. The series came to an end in November, 1857, and in the following year the publication of Adam Bede placed her in the first rank of writers of fiction. It was succeeded by the *Mill on the Floss* (1860), *Silas Marner* (1861), *Romola* (1863), *Felix Holt* (1866), *Middlemarch* (1872), and *Daniel Deronda* (1876). In addition to those prose works she published three volumes of poems, *The Spanish Gypsy* (1868), *Agatha* (1869), and the *Legend of Jubal* (1874). Her last work published during her life was the series of essays entitled *The Impressions of Theo-*

phrastus Such (1879), but a volume of mixed essays was issued posthumously. For many years she was happily associated both in life and work with George Henry Lewes, though a legal union was impossible during the lifetime of Mrs. Lewes. In May, 1880, after Mr. Lewes' death, she married Mr. John Cross, but did not survive the marriage many months, dying rather suddenly at Chelsea on the 22d December of that year.

Eliot, SIR JOHN, one of the ablest of the popular leaders of Charles I.'s reign, of an old Cornwall family, born in 1570. He entered parliament in 1614 as member for St. Germans, winning immediate reputation as an orator. As vice-admiral of Devon he was energetic in suppressing piracy. In the three parliaments of 1623, 1625, 1626, he made his way to the front of the constitutional party, joined Hampden and the rest in refusing contributions to the forced loan, and took a prominent share in drawing up the Remonstrance and Petition of Right. He was imprisoned in the Tower in 1629, and died still in confinement in 1632. During his imprisonment he wrote a work on constitutional monarchy entitled the *Monarchy of Man*.

El'is, a maritime state of ancient Greece in the west of the Peloponnesus, bordering on Achaia, Arcadia, and Messenia, and watered by the rivers Alphēus and Penēus. Of its capital Elis (now Kaloskopoi) there are few traces. Olympia, where the famous games were held, was near the Alpheus. Elis and Achaia now form a nomarchy of Greece.

Eli'sha, a Hebrew prophet, the disciple and successor of Elijah. Many miracles of prediction and cure, and even of raising the dead, are ascribed to him, but his figure is less original and heroic than that of his master. He held the office of prophet for fully sixty-five years, from the reign of Ahab to that of Joash (latter half of 9th century B.C.).

Elissabetgrad, ELIZABETGRAD. See ELIZABETHGRAD.

Elix'ir, a word of Arabic origin, applied by the alchemists to a number of solutions employed in attempting the transmutation of metals into gold, and also to a potion, the *elixir vite*, or elixir of life, supposed to confer immortality. It is still used for various popular remedies, for the most part composed of various aromatic and stimulative substances held in solution by alcohol.

ELIZABETH.

Elizabeth, Queen of England, daughter of Henry VIII. and of Anne Boleyn, was born at Greenwich September 7th, 1533, and almost immediately declared heiress to the crown. After her mother had been beheaded (1536) both she and her sister Mary were declared bastards, and she was finally placed after Prince Edward and the Lady Mary in the order of succession. On the accession of Edward VI. Elizabeth was committed to the care of the queen-dowager Catherine; and after the death of Catherine



Queen Elizabeth.

and beheadal of her consort Thomas Seymour she was closely watched at Hatfield, where she received a classical education under William Grindal and Roger Ascham. At the death of Edward Elizabeth vigorously supported the title of Mary against the pretensions of Lady Jane Grey, but continued throughout the whole reign an object of suspicion and surveillance. In self-defence she made every demonstration of zealous adherence to the Roman Catholic faith, but her inclinations were well known. On 17th November, 1558, Mary's reign came to a close, and Elizabeth was immediately recognized queen by parliament. The accuracy of her judgment showed itself in her choice of advisers, Parker, a moderate divine (Archbishop of Canterbury 1559), aiding her in ecclesiastical policy; while William Cecil, Lord Burleigh, assisted her in foreign affairs. The first great object of her reign was the settlement of religion, to effect which a parliament was called on 25th January, and dissolved on the 8th May, its object having been

accomplished. The nation was prepared for a return to the Reformed faith, and the parliament was at the bidding of the court. The ecclesiastical system devised in her father's reign was re-established, the royal supremacy asserted, and the revised prayer-book enforced by the Act of Uniformity. While, however, the formal establishment of the reformed religion was easily completed, the security and defence of the settlement was the main object of the policy and the chief source of all the struggles and contentions of her reign. Freed from the tyranny of Mary's reign the Puritans began to claim predominance for their own dogmas, while the supporters of the Established Church were unwilling to grant them even liberty of worship. The Puritans, therefore, like the Catholics, were made irreconcilable enemies of the existing order, and increasingly stringent measures were adopted against them. But the struggle against the Catholics was the most severe, chiefly because they were supported by foreign powers; so that while their religion was wholly prohibited, even exile was forbidden them, in order to prevent their intrigues abroad. Many Catholics, particularly priests, suffered death during this reign; but simple nonconformity, from whatever cause, was pursued with the severest penalties, and many more clergymen were driven out of the church by differences about the position of altars, the wearing of caps, and such like matters, than were forced to resign by the change from Rome to Reformation. Elizabeth's first parliament approached her on a subject which, next to religion, was the chief trouble of her reign, the succession to the crown. They requested her to marry, but she declared her intention to live and die a virgin; and she consistently declined in the course of her life such suitors as the Duc d'Alençon, Prince Erik of Sweden, the Archduke Charles of Austria, and Philip of Spain. While, however, she felt that she could best maintain her power by remaining unmarried, she knew how to temporize with suitors for political ends, and showed the greatest jealousy of all pretenders to the English succession. With the unfortunate Mary, queen of Scots, were connected many of the political events of Elizabeth's reign. On her accession the country was at war with France. Peace was easily concluded (1559); but the assumption by Francis and Mary of the royal arms and titles of England led to an immediate inter-

ference on the part of Elizabeth in the affairs of Scotland. She entered into a league with the Lords of the Congregation, or leaders of the Reformed party; and throughout her reign this party was frequently serviceable in furthering her policy. She also gave early support to the Huguenot party in France, and to the Protestants in the Netherlands, so that throughout Europe she was looked on as the head of the Protestant party. This policy roused the implacable resentment of Philip, who strove in turn to excite the Catholics against her both in her own dominions and in Scotland. The detention of Mary in England (1568–87), whither she fled to the protection of Elizabeth, led to a series of conspiracies, beginning with that under the Earls of Northumberland and Westmoreland, and ending with the plot of Babington, which finally determined Elizabeth to make away with her captive. The execution of Queen Mary (1587), though it has stained her name to posterity, tended to confirm her power among her contemporaries. The state of France consequent on the accession of Henry IV., who was assisted by Elizabeth, obviated any danger from the indignation which the deed had caused in that country; and the awe in which King James stood of Elizabeth and his dread of interfering with his own right of succession to England made him powerless. But Philip was not to be so appeased, the execution of Mary lending edge to other grievances. The fleets of Elizabeth had galled him in the West Indies, her arms and subsidies had helped to deprive him of the Netherlands; the Armada was already in preparation. Accordingly he called the Queen of England a murderess, and refused to be satisfied even with the sacrifice she seemed prepared to make of her Dutch allies. The Armada sailed on 29th May, 1588. Its fate is too well known to need recapitulation. (See *Armada*.) The war with Spain dragged on till the close of Elizabeth's long reign. During her reign the splendour of her government at home and abroad was sustained by such men as Burleigh, Bacon, Walsingham, and Throgmorton; but she had personal favourites of less merit who were often more brilliantly rewarded. Chief of these were Dudley, whom she created Earl of Leicester, and whom she was disposed to marry, and Essex, whose violent passions brought about his ruin. He was beheaded in 1601, but Elizabeth never forgave herself his death. Her own health soon after gave

way, and she died on 24th March, 1603, naming James VI. of Scotland as her successor.

Elizabeth, a city of New Jersey, United States, 14 miles s.w. from New York, with which it has ample communication by railway and steamer. It is a favourite residence of New York business men. The Singer Sewing Machine Co. has a large factory here, and there are also foundries, oil-cloth factories, &c. Pop. 1890, 37,764.

Elizabeth, St., of Thuringia, daughter of Andreas II., king of Hungary, was born at Pressburg 1207, and in 1221 married to Ludwig, landgrave of Thuringia. She erected hospitals, fed a multitude of poor from her own table, and wandered about in a humble dress, relieving the wretched. Louis died on a crusade, and her own life terminated Nov. 19, 1231, in a hospital which she had herself established. The church over her tomb at Marburg is one of the most splendid Gothic edifices in Germany.

Elizabethan Architecture, a style of architecture which prevailed in England

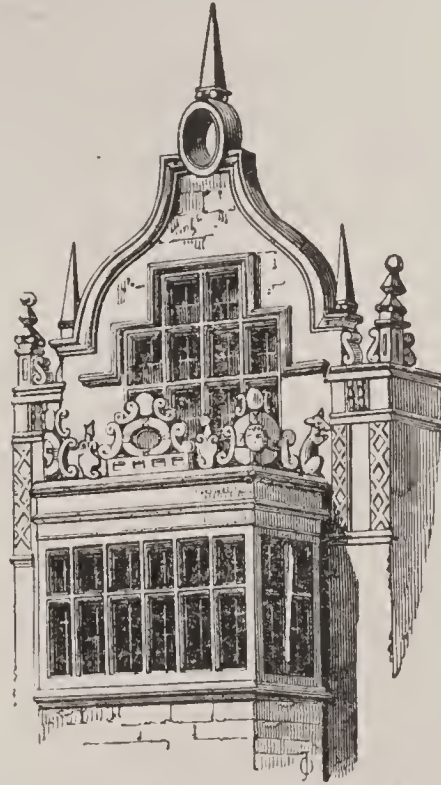

Elizabethan Window, Rushton Hall.

during the reigns of Elizabeth and James I. It succeeded to the Tudor style, properly so called, with which it is sometimes confounded. The Elizabethan is a mixture of inferior Gothic and debased Italian, producing a singular heterogeneousness in detail, with, however, wonderful picturesqueness in general effect, and domestic accommo-

dition more in accordance with the wants of an advancing civilization than was afforded by the styles which preceded it. The chief characteristics of Elizabethan architecture are: windows of great size both in the plane of the wall and deeply embayed, ceilings very richly decorated in relief, galleries of great length, very tall and highly-decorated chimneys, as well as a profuse use of ornamental strap-work in the parapets, window-heads, &c. The Elizabethan style is the

last stage of the Tudor or Perpendicular, and from its corresponding in point of period with the Renaissance of the Continent has sometimes been called the English Renaissance. The epithet Jacobean has sometimes been given to the very latest stage of the Elizabethan, differing from the Elizabethan proper in showing a greater admixture of debased Italian forms. The princely houses which arose during the reign of Elizabeth are numerous, and many even yet remain

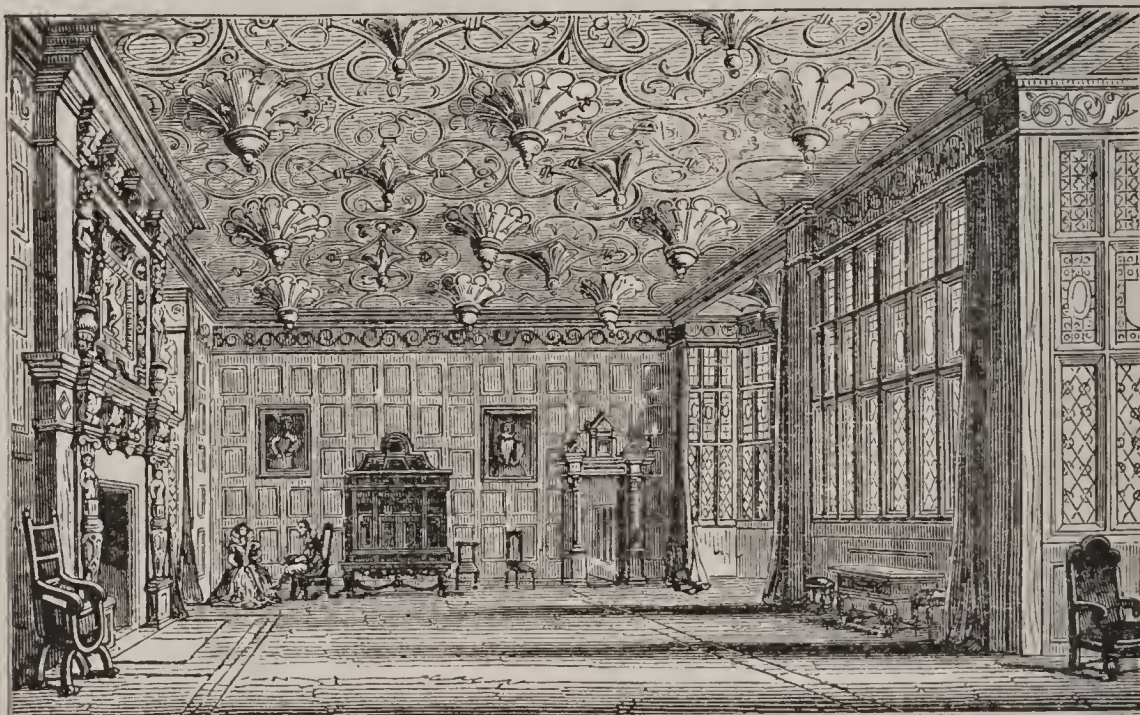

Drawing-room of Bramhall Hall, Cheshire. Time of Elizabeth.

to attest the splendour of the time. Of these may be mentioned Burghley House, Hardwick Hall, and Bramhall Hall.

Elizabeth Farnese (fār-nā'zā), Queen of Spain, daughter of Edward II., prince of Parma, born 1692. On becoming the second wife of Philip V. she surprised those who had counselled the marriage by assuming the practical headship of the kingdom, and her ambition and that of her minister Alberoni disturbed the whole of Europe. The 'terragrant tenacious woman,' as Carlyle called her, died in 1766.

Elizabethgrad, a town of Southern Russia, on the Ingul, with an imperial palace, a theatre, manufactures of soap, candles, &c., and several great fairs. Pop. 58,496.

Elizabeth Islands, a group of sixteen American islands south of Cape Cod, with a permanent population of about 100.

Elizabeth of Valois, or **ISABELLA**, Queen of Spain, was born in 1545, daughter of Henry II. of France and Catherine de' Medici. She was destined by the Treaty of

Cateau-Cambrésis to be the wife of the infante, Don Carlos, but his father, Philip II., being left a widower, became fascinated and married her himself. She died in 1568. The stories of a romantic relationship existing between Elizabeth and Don Carlos are entirely groundless, but have furnished tragic subjects to Otway, Campistron, Chénier, Schiller, and Alfieri.

Elizabeth Petrowna, Empress of Russia, daughter of Peter the Great and Catharine, born in 1709 or 1710, ascended the throne on 7th Dec. 1741, as the result of a conspiracy, in which Ivan VI., a minor, was deposed. Elizabeth is said to have rivalled her mother in beauty, and to have surpassed her in her love of pleasure, and her government was largely conducted by favourites. She was a patron of literature, founded the University of Moscow, and corresponded with Voltaire. A war with Sweden, in 1743, was advantageously concluded by the peace of Åbo. She sent an army, in 1748, to assist Maria Theresa in the war of the

Succession, and joined in the Seven Years' war against Prussia. She died in 1762, before this war was concluded.

Elizabethpol, a town of Russia, in the Caucasus, capital of the gov. of same name, covering a great space of ground from the gardens and open areas it contains, but very unhealthy. Pop. 18,505.—The gov. has an area of 17,000 sq. miles, a pop. of 636,316. It is partly mountainous, partly steppes, and produces grain, cotton, tobacco, wine, &c.

Elizabeth Stuart, Queen of Bohemia, daughter of James I. of England and VI. of Scotland, born in Falkland Palace, Fifeshire, 1596. Her marriage with the Palatine Frederick was celebrated at Whitehall in 1613. Her husband, then at the head of the Protestant interest in Germany, accepted in 1619 the crown of Bohemia offered to him by the revolted Protestants of that country; but after his defeat by the imperialists at the battle of Prague in 1620 he and his wife were obliged to flee, first to Breslau and Berlin, and then to the Hague. She returned to England at the Restoration with her nephew Charles II., and died at Leicester House, London, on 13th Feb. 1662. Elizabeth had thirteen children, of whom Charles Louis, the eldest surviving, was reinstated in the palatinate by the Treaty of Westphalia in 1648. By her daughters, Elizabeth Charlotte and Sophia, she was the ancestress of Louis Philippe and of George I., and her sons, Rupert and Maurice, became famous Cavalier leaders.

Elk, MOOSE, OR MOOSE DEER (*Cervus alces* or *Alces Malchis*), the largest of the



Head of Elk (*Cervus alces*).

deer family, a native of northern Europe, Asia, and America. The American form (to which the name moose is usually given) is sometimes separated from the European as *Alces americanus*, but most naturalists find no specific difference between them.

The elk or moose has a short compact body, standing about 6 feet in height at the shoulders, a thick neck, large clumsy head, and horns which flatten out almost from the base into a broad palmate form with numerous snags. In colour the elk is grayish brown, the limbs, sides of head, and coarse mane being, however, of a lighter hue. Their flesh resembles beef rather than venison. For the most they are inoffensive, and so exceedingly wary that they are approached only with difficulty. In America the Indians and half-breeds are the most skilful moose-hunters. The moose has a wide range in Canada, extending from the Arctic Ocean and British Columbia to New Brunswick and Nova Scotia; and it is found also in Maine. It feeds largely on the shoots of trees or shrubs, such as the willow and maple, and on bark, &c. In Sweden its destruction is illegal, and in Norway there are many restrictions.

Elk, IRISH (*Megaceros hibernicus*), a large deer found in the Pleistocene strata, and distinguished by its enormous antlers, the tips of which are sometimes 11 feet apart. Though a true deer, its antlers differ from those of living species in that the beam is flattened into a palm. To sustain the great weight, unusually large and strong limbs and neck vertebræ were required. Its remains are found not only in Ireland but in Scotland and England, and on the Continent, where they occur in lacustrine deposits, brick-clay, and ossiferous caves.

El Khargeh. See *Khargeh*.

Elk'hart, a town of Indiana, U. States, on Elkhart River, with railroad works, paper-mills, &c. Pop. 11,360.

Elkins, STEPHEN B., Secretary of War, was born in Perry co., Ohio, Sept. 26, 1841. In New Mexico had extensive business interests; afterward in West Virginia. Appointed Secretary of War in 1891.

Ellenborough, EDWARD LAW, LORD, English lawyer, Lord Chief-justice of the King's-bench, born in 1750 at Great Salkeld, Cumberland, educated at the Charter House and at Cambridge, called to the bar in 1780. He early obtained a silk gown, and at the trial of Warren Hastings, in 1785, acted as leading counsel. The defence did not come on until the fifth year of the trial, but after eight years Hastings was acquitted and Law's success assured. In 1801 he was made attorney-general, and in 1802 became Lord Chief-justice of the King's-bench, and was created baron. He held

the office of chief-justice for fifteen years, resigning in 1818, in which year he died.

Ellenborough, EDWARD LAW, FIRST EARL OF, son of Lord Chief-justice Ellenborough (see above), born in 1790. He was educated at Eton and Cambridge, and in 1818, having succeeded his father as second baron, he entered the House of Lords. He took office in 1818 as lord privy-seal, and became president of the board of control in 1828-30, and again in 1834. In 1841 he accepted the governor-generalship of India, and arrived in Calcutta in 1842, in time to bring the Afghan war to a successful issue. The annexation of Scinde in 1843 was followed by the conquest of Gwalior, but the conduct of the governor-general gave dissatisfaction at home, and he was recalled early in 1844. On his return, however, he was defended by Wellington, and received the thanks of parliament, an earldom, and the Grand Cross of the Bath. He then held the post of first lord of the admiralty (1845-46), and was president of the board of control from February to June, 1858. His despatch censuring the policy of Lord Canning as Governor-general of India led to his resignation, and he never resumed office. He died in 1871.

Ellichpur (el-ich-pör'), a town of India, in Ellichpur district, Berar, once a large and prosperous town. There is a military cantonment within two miles. Pop. 26,728.

Ellicott, RIGHT REV. CHARLES JOHN, English divine, born 1819, and educated at Cambridge. After being professor of divinity in King's College, London, Hulsean lecturer and Hulsean professor of divinity at Cambridge, and dean of Exeter, he was appointed bishop of Gloucester and Bristol in 1863. He was for eleven years chairman of the scholars engaged on the revision of the New Testament translation, and has published commentaries on the Old and the New Testament, as well as numerous sermons, addresses, lectures, &c.

Elliot, GEORGE AUGUSTUS. See *Heathfield*.

Elliott, EBENEZER, English poet, known as the 'Corn-law Rhymer,' was born in 1781 near Rotherham, Yorkshire. At the age of seventeen he published his first poem, the *Vernal Walk*, which was soon followed by others. In 1829 the *Village Patriarch*, the best of Elliott's larger pieces, was published. From 1831 to 1837 he carried on business as an iron merchant in Sheffield. His *Corn-law Rhymes*, periodically contributed to a local paper on behalf of the repeal of these

laws, attracted attention, and were afterwards collected and published with a longer poem entitled *The Ranter*. Commercial losses compelled him in 1837 to contract his business, and in 1841 he retired from it altogether, and died in 1849. In 1850 two posthumous volumes appeared, entitled *More Prose and Verse by the Corn-law Rhymer*.

Ellipse', a figure in geometry ranking next in importance to the circle, and produced when any cone is cut by a plane which passes through it not parallel to nor cutting the base. Kepler discovered that the paths described by the planets in their revolutions round the sun are ellipses, the sun being placed in one of the foci.

To describe an ellipse:—At a given distance on the surface on which the ellipse is to be described fix two pins, A and B, and pass a

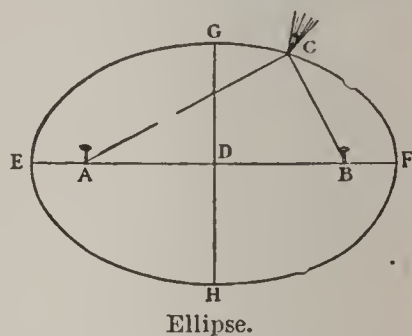

looped string round them. Keep the string stretched by a pencil, C, and move the pencil round, keeping the string at the same tension, then the ellipse EGFH will be described. F and G are the *foci*, D the centre, E F the major axis, and G H the minor axis, D A or D B is the *eccentricity* of the ellipse. A line drawn from any point in the curve perpendicularly to the axis is an ordinate to the axis. Any straight line drawn through the centre and terminated both ways by the curve is called a diameter.

Ellip'sis, in grammar, the omission of one or more words, which may be easily supplied by the connection.

Elliptic'ity OF THE EARTH, the deviation of the form of the earth from that of a sphere. See *Earth, Degree*.

Ellis, ALEXANDER JOHN, English philologist, born 1814 (name originally Sharpe). He was a distinguished graduate of Trinity College, Cambridge, was elected to the Royal Society in 1864, and has long been an influential member of the Philological Society, being more than once its president. Though phonetics is the subject in which he has most highly distinguished himself, he is equally at home in mathematical and musical subjects. His chief published work is *Early English Pronunciation* (parts i.-iv., 1869-75), as yet incomplete; but his publications in the form of books, pamphlets,

papers, and articles on phonetics, music, mathematics, &c., are numerous.

Ellis, GEORGE, English man of letters, born in 1753, and educated at Westminster School and Trinity College, Cambridge. He was one of the junta of wits concerned in the well-known political satire, *The Roliad*, contributed to the *Anti-Jacobin*, wrote a preface, notes, and appendix to Way's translation of *Le Grand's Fabliaux*, and published *Specimens of the Early English Poets*, with an *Historical Sketch* (1790), and *Specimens of Early English Metrical Romances* (1805). He died in 1815. He was an intimate friend of Sir Walter Scott.

Ellis, WILLIAM, English missionary, born 1794, died 1872. He was sent out to the South Sea Islands in 1816 by the London Missionary Society, and returned in 1825, one result of his labours being *Polynesian Researches* (1829). In 1830-44 he was secretary to the society, and afterwards on its behalf made several visits to Madagascar, the longest being in 1861-65. These visits led him to publish *Three Visits to Madagascar* (1858), *Madagascar Revisited* (1867), and the *Martyr Church of Madagascar* (1870).

Ello'ra, or **ELO'RA**, a ruinous village, Hindustan, Deccan, Nizam's Dominions, 13 miles north-west of Aurangabad, famous for its rock and cave temples excavated in the crescent-shaped scarp of a large plateau. They run from north to south for about a mile and a quarter, and consist of five Jain caves towards the north, seventeen Brahmanical caves at the centre, and towards the south twelve Buddhistic caves. Of the temples some are cut down through the rock, and left open above like isolated buildings, others are excavated under the hill in the manner of caves properly so called. The interior walls are often richly carved with mythological designs. The most magnificent of the whole is the Hindu temple called *Kailas* or *Cailas*, the central portion of which forms an isolated excavated mass or immense block 500 feet in circumference and 100 feet high. It is surrounded by galleries or colonnades at the distance of 150 feet, in which the whole Hindu pantheon is cut in the perpendicular rock. Another fine temple, much smaller, but cut under the hill, is the Buddhist cave of *Visvakarma*, the only one excavated with a curved roof. The date of the caves is not certainly known, but they were probably the work of the reigning families at the neighbouring *Deoghir*.

Ellsworth, OLIVER, jurist, was born in Windsor, Conn., April 29, 1745. John Adams styled him "the finest pillar of Washington's administration." In 1796 appointed Chief Justice of the Supreme Court of the U. S. He died in 1807.

Ellwood, THOMAS, an early writer among the Quakers, born in 1639. About 1660 he was induced to join the Society of Friends, and soon after published *An Alarm to the Priests*. He was imprisoned on account of his religion, but subsequently became reader to Milton, and is said to have suggested to him the idea of writing the *Paradise Regained*. In 1705 and 1709 he published the two parts of his *Sacred History*. His works include a poetical life of King David, the *Davideis*. He died in 1713.

Elm, a genus of trees (*Ulmus*; nat. order, *Ulmaceæ*), consisting of thirteen species, all natives of the northern temperate zone. They have bisexual flowers with a campanulate calyx, as many stamens as there are divisions in the limb of the calyx, and two styles. Two species are common in Britain, *U. campestris* and *U. montana*, with many varieties. The *U. campestris*, or common elm, is a fine tree, of rapid and erect growth, and yielding a tall stem, remarkable for the uniformity of its diameter throughout. It is very common as a timber tree in England; but as it rarely produces seed it is questionable whether it is indigenous. It is a native of the south and middle of Europe, and the west of Asia. The average height of a mature tree is 70 or 80 feet, but some reach 150 feet. The wood is brown, hard, of fine grain, not apt to crack, and is used for many purposes. The tree generally attains maturity in seventy or eighty years. *U. montana* (the mountain or *wych elm*), a native of Scotland, grows to a less height than the English elm, is of slower growth, and yields a much shorter bole, but it is far bolder in its ramification and more hardy. It usually attains to the height of about 50 feet. It does not produce suckers, like the English elm, but yields seed freely. The timber is strong and elastic, and the tree often yields large protuberances of gnarled wood, finely knotted and veined, and much esteemed for veneering. *U. glabra*, the smooth-leaved elm, is a species common in some parts of Britain. It first appeared about the middle of last century. The most ornamental tree of the genus is *U. pendula*, the weeping elm. The American or white elm (*U. americana*) is abundant in the Western States, attain-

ing its loftiest stature between lat. 42° and 46°; here it reaches the height of 100 feet, with a trunk 4 or 5 feet in diameter, rising sometimes 60 or 70 feet before it separates into a few primary limbs. Its wood is not much esteemed. The red or slippery elm (*U. fulva*) is found over a great extent of country in Canada, Missouri, and as far south as lat. 31°; it attains the height of 50 or 60 feet, with a trunk 15 or 20 inches in diameter; the wood is of better quality than that of the white elm. The leaves and bark yield an abundant mucilage. The wahoo (*U. alata*), inhabiting from lat. 37° to Florida, Louisiana, and Arkansas, is a small tree, 30 feet high. The branches are furnished on two opposite sides with wings of cork 2 or 3 lines wide; the wood is fine-grained and heavy.

Elmi'na, a British town and seaport on the west coast of Africa, 5 or 6 miles west of Cape Coast Castle. It was acquired by Britain in 1872 along with the other Dutch possessions here. Pop. 20,000.

Elmi'ra, a town of the U. States, N. York, on the Chemung river; with a college for women, the state reformatory, fine courthouse, &c. Its industrial establishments comprise rolling-mill, blast-furnace, foundries, machine-works, &c. Pop. 30,893.

Elmo's Fire, St., a meteoric appearance often seen playing about the masts and rigging of ships. If two flames are visible (Castor and Pollux) the sailors consider it a good omen; if only one (Helena), they regard it as a bad one.

Elmshorn, a town, Prussia, Holstein, 20 miles north-west of Hamburg, on the Krückau, a navigable stream. Pop. 8712.

Elmsley, PETER, D.D., English scholar, born in 1773, and educated at Oxford. He was one of the original contributors to the Edinburgh Review, and wrote occasionally, at a subsequent period, in the Quarterly. He finally settled at Oxford, where he held the headship of St. Alban Hall and the Camden professorship of ancient history in 1823. He died in 1825. He published editions of the *Œdipus Tyrannus* (1811), *Heraclidæ* (1815), *Medea* (1818), *Bacchæ* (1821), and *Œdipus Coloneus* (1823).

El Obeid. See *Obeid*.

Elocution, the art by which, in delivering a discourse before an audience, the speaker is enabled, with greatest ease and certainty, to render it effective and impressive. The value of an elocutionary training is very great, as well in sparing the voice as in

overcoming natural defects or provincialisms in delivery, and in cultivating and developing the natural taste.

Eloge (ā-lōzh; French, eulogy), a discourse pronounced in public in honour of an illustrious person recently deceased, peculiarly a French institution.

Elo'him (plural of *Eloah*), one of the Hebrew names for God, of frequent occurrence in the Bible. Elohim is used in speaking both of the true God and of false gods, while Jehovah is confined to the true God. The plural form of Elohim has caused a



Mountstuart Elphinstone.

good deal of controversy, some considering it as containing an allusion to the doctrine of the Trinity, others regarding it as the plural of excellence, others holding it as establishing the fact of a primitive polytheism. The Elohist passages in the Pentateuch, or, in other words, the passages in which the Almighty is always spoken of as Elohim, are supposed to have been written at an earlier period than those in which he is spoken of as Jehovah. The Elohist passages are simpler and more primitive in character than the Jehovistic; thus Gen. i. 27 is Elohist; Gen. ii. 21–24 is Jehovistic.

El Paso, El Paso co., Tex., on the Rio Grande, near the border of Mexico. Pop., including Fort Bliss, 1890, 10,338.

Elopu'ra, a seaport of British North Borneo, on Sandakan Bay. Pop. 8000.

Elphinstone, HON. MOUNTSTUART, Indian administrator, son of the eleventh Lord

Elphinstone, born in Scotland in 1778. He joined the Bengal civil service in 1795, was ambassador to the Afghan court in 1808, was resident at the court of Poonah from 1810 to 1817, and was British commissioner to that province from 1817 to 1819, when he became governor of Bombay. During a government of seven years he established a code of laws, lightened taxes, and paid great attention to schools and public institutions. He resigned in 1827. A college established by the natives was called after him Elphinstone College. He was the author of an *Account of the Kingdom of Cabul and its Dependencies* (1815), and a *History of India* (1841). He was offered the governor-generalship of India in 1835, and afterwards that of Canada, both of which he declined. He died in 1859.

Elphinstone, WILLIAM, a Scottish prelate, founder of King's College and University, Aberdeen, born at Glasgow in 1431. He was educated at Glasgow College, and served four years as priest of St. Michael's in that city. He then went to France and became professor of law, first at Paris and subsequently at Orleans, but about 1471-74 he returned home at the request of Muirhead, bishop of Glasgow, who made him commissary of the diocese. In 1478 he was made commissary of the Lothians, and in 1479 Archdeacon of Argyle. Soon after he was made Bishop of Ross; and in 1483 was transferred to the see of Aberdeen. In 1484 and 1486 he was commissioned to negotiate truces with England, and in 1488 was lord high-chancellor of the kingdom for several months. He was next sent on a mission to Germany, and after his return held the office of lord privy-seal till his death in 1514. In 1494 he obtained a papal bull for the erection of the university of King's College at Aberdeen.

Elsass. See *Alsace*.

Elsass-Lothringen (lõt'ring-èn). See *Alsace-Lorraine*.

Elsinore' (Danish, *Helsingör*), a seaport of Denmark, in the island of Seeland, at the narrowest part of the Sound, here only 3½ miles broad, 24 miles north by east of Copenhagen, opposite Helsingborg in Sweden. Elsinore is defended by the castle of Kronborg, a Gothic-Byzantine edifice built about 1580, and commanding the Sound. It is now chiefly used as a prison. Before the abolition of the Sound dues in 1857 all merchant ships passing through were bound to pay toll here. Pop. 8978.

Elster, two German rivers, the White or Great Elster, a tributary of the Saale; the Black Elster, a tributary of the Elbe.

Elswick (els'ik), a suburb of Newcastle, England, containing the great ordnance works of Armstrong & Co. Pop. 35,000.

Elu'triation, the process of separating the finer particles of a clay, earth, or similar mass from the coarser, consisting in stirring up the substance in water, letting the coarser particles subside, running off the liquid containing the finer particles, and then waiting till they subside.

Elvas, a town, Portugal, province of Alemtejo, near the Spanish frontier, 12 miles north-west of Badajoz, on a height flanked by two others, each crowned by a castle. It has a cathedral, partly Moorish and partly Gothic, and a Moorish aqueduct, a magnificent work which brings water from a distance of 15 miles. Pop. 10,471.

Elves. See *Fairies*.

Elwes, JOHN, an English miser, born about 1712. His own name was Meggot, but he changed it on succeeding to an estate left him by his uncle, Sir Harvey Elwes. He was educated at Westminster School, and in his younger days was noted for his skill in horsemanship and love of the chase. He was elected member for Berks in 1774. His fortune and parsimonious habits increased in equal ratio, and at his death in 1789 he left, besides entailed estates, a fortune of half a million to his two natural sons.

Ely (ē'li), an episcopal city of England, in the county of Cambridge, on an eminence on the left bank of the Ouse. The ecclesiastical structures comprise the cathedral and the churches of St. Mary, and the Holy Trinity, the last belonging to the time of Edward II., and one of the most perfect buildings of that age. The superb cathedral occupies the site of a monastery founded about the year 673 by Etheldreda, daughter of the king of East Anglia. Its entire length, east to west, is 517 feet, and its west tower is 270 feet high. The whole structure comprises an almost unbroken series of the various styles of architecture which prevailed in England from the Conquest to the Reformation, yet with no loss of impressiveness as a whole. It has undergone of late years extensive additions and restoration. A fine gateway, built in the reign of Richard II., forms the principal entrance to the cathedral precincts. There are a few manufactures, but most of the inhabitants are engaged in agricultural labour. Pop. 8125.

Ely, ISLE OF, a district in England, in the county of Cambridge, separated on the south by the Ouse from the remaining portion of the county. It is about 28 miles long by 25 miles broad; area, 227,326 acres.

Elyria, Lorain co., Ohio, 25 miles w. of Cleveland. Manufactures, grindstones and tobacco. Pop. 1890, 5611.

Elys'ium, ELYSIAN FIELDS, among the Greeks and Romans the regions inhabited by the blessed after death. They are placed by Homer at the extremities of the earth, by Plato at the antipodes, and by others in the Fortunate Islands (the Canaries). They were at last transferred to the interior of the earth, which is Virgil's notion. The happiness of the blessed consisted in a life of tranquil enjoyment in a perfect summer land, where the heroes, freed from all care and infirmities, renewed their favourite sports.

Ely'tra, the hard bony cases which inclose the wings of coleopterous insects or beetles. They are themselves wings, but are less important for flight than for protecting the true wings when folded beneath them in a state of repose.

Elze (el'tse), KARL, German writer, distinguished for his studies in English literature, born 1821, died 1889. He studied in Leipzig and Berlin, was long a teacher in the gymnasium of his birthplace, Dessau, and in 1875 was appointed to the chair of the English language and literature at Halle. Among his writings were valuable biographies of Sir Walter Scott and Lord Byron (the latter translated into English), and a biographical and critical work on Shakspeare, also translated into English (1888).

El'zevir, or ELZEVIER, the name of a family of publishers and printers, residing at Amsterdam and Leyden, celebrated for the beauty of the editions of various works published by them, principally from 1595 to 1680. LOUIS, the founder of the family (born 1540, died 1617), settled in Leyden, and between 1583 and his death produced about 150 works. Five of his seven sons followed his business:—MATTHÆUS at Leyden; LOUIS (II.) at the Hague; GILLES at the Hague and afterwards at Leyden; JOOST in Utrecht; and BONAVENTURE, who in 1626 associated himself with ABRAHAM, the son of Matthæus. From the press of Abraham and Bonaventure issued the exquisite editions of the classics, &c., which have made the name of Elzevir famous. Of these the

Livy and Tacitus of 1634, the Pliny of 1635, the Virgil of 1636, and the Cicero of 1642 are perhaps the most beautiful.

Emanation, in a specific sense, an idea at the centre of many philosophic systems which seek to explain the universe as an eternal efflux or emanation from the Supreme Being, comparable with the efflux of light from the sun. Traces of the doctrine are found in the system of Zoroaster. It had a powerful influence on the ancient Egyptian and Greek philosophy.

Emancipation Proclamation was issued by President Lincoln, Jan. 1, 1863, 'as a fit and necessary war measure for suppressing rebellion.' It freed all slaves in any states and portions of states actually in rebellion, and which were unrepresented in congress, or not in possession of the Union armies.

Eman'uel the Great, King of Portugal, ascended the throne in 1495. During his reign were performed the voyages of discovery of Vasco da Gama, of Cabral, of Americus Vesputius, and the heroic exploits of Albuquerque, by whose exertions a passage was found to the East Indies, the Portuguese dominion in Goa was established, the Brazils, the Moluccas, &c., were discovered. The commerce of Portugal, under Emanuel, was more prosperous than at any former period. The treasures of America flowed into Lisbon, and the reign of Emanuel was justly called 'the golden age of Portugal.' He died in 1521, aged fifty-two, deeply lamented by his subjects, but hated by the Moors and the Jews, whom he had expelled. He was a patron of learned men, and himself left memoirs on the Indies. He married three times:—in 1497 Isabella, daughter of Ferdinand and Isabella, heiress of Castile; in 1500 her sister Maria; and in 1519 Eleonora of Austria, sister of Charles V.

Embalming (em-bäm'ing), the process of filling and surrounding with aromatic and antiseptic substances any bodies, particularly corpses, in order to preserve them from corruption. The ancient Egyptians employed the art on a great scale, and other peoples, for example the Assyrians and Persians, followed them, but by no means equalled them in it. The ancient Peruvians appear to have injected and washed the corpses with the fluid that flows from imperfectly burned wood, which would of course contain pyroligneous acid, creosote, and other antiseptics. Pliny alludes to the use of a similar fluid by the Egyptians for embalming. In later times bodies have been preserved

a long time by embalming, especially when they have remained at a low and uniform temperature, and have been protected from the air. The body of Edward I. was buried in Westminster Abbey in 1307, and in 1770 was found entire. Canute died in 1036; his body was found very fresh in 1776 in Winchester Cathedral. The bodies of William the Conqueror and of Matilda his wife were found entire at Caen in the 16th century. Of the various modern artificial means of preserving bodies, impregnation with corrosive sublimate appears to be one of the most effective, next to immersion in spirits. An injection of sulphate of zinc into the blood-vessels is said to be very effective.

Embankment, a mound of earth, &c., thrown up either for the purpose of forming a roadway at a level different from that of the natural surface of the ground, or for keeping a large body of water within certain limits. The slopes should be adapted to the material, so as to secure permanence. Thus the slope of loose rubble, chalk, stone, loamy sand, or gravel, requires about $1\frac{1}{2}$ base to 1 vertical; dry, loose and ordinary clay, 2 horizontal to 1 vertical, while some clays require a much wider base. To prevent subsidence on marshy or peaty soils, either the weight of the heart of the embankment is diminished, as in Holland, by introducing layers of reeds or fascines, or artificial foundations are prepared. The embankment may be prevented from slipping laterally by forming steps in the earth of the subsoil, or by cutting deep trenches at the feet of the slopes. In cases where embankments are raised for the storage of water, a 'puddle-dike,' that is, a water-tight wall, must be inserted through the whole depth of the bank down to the impermeable strata beneath. To resist the action of wind and rain, or of the waters of a slow-flowing stream, the banks should in all possible cases be covered with turf. Among the largest embankments hitherto executed are those on the banks of the Po, the Meuse, the Scheldt; on the shores of the Netherlands; the Oberhäuser embankment on the Augsburg and Lindau Railway, the Gadelbach cutting on the Ulm and Augsburg line, and the **Tring cutting** on N.W. Railway (England).

Embargo Act, passed by the congress of the United States, Dec. 21, 1807, caused by England's prohibition of all commerce with France, a similar prohibition by France, blockades by each, and searches of neutrals by both. The act prohibited American ves-

sels sailing from foreign ports, and foreign vessels taking cargoes from American ports. It was enforced until March 5, 1809.

Em'bassy, in its strict sense, signifies a mission presided over by an ambassador, as distinguished from a legation or mission intrusted to an envoy. An ambassador, as the representative of the person of his sovereign, can demand a private audience of the sovereign to whom he is accredited, while an envoy must communicate with the minister for foreign affairs.

Embattled, in architecture and heraldry, having a form or outline like the battlements of a castle.

Ember-days, in the Anglican and R. Catholic Churches, fast-days occurring at the times in the year appointed for ordinations. As now observed they are the Wednesday, Friday, and Saturday after the first Sunday in Lent, after the feast of Pentecost or Whitsunday, after the festival of the Holy Cross (14th Sept.), and after the festival of St. Lucia (13th Dec.). The weeks in which these days fall are called *Ember-weeks*.

Ember-goose, a bird, known also as the great northern diver and loon. See *Divers*.

Emberiz'idæ, a family of small birds belonging to the order Insectivores and tribe Conirostres, typical genus *Emberiza*. It includes the buntings, the snow-flake, the yellow-hammer, and reed sparrow. The ortolan belongs to this family. By some naturalists they are classified as a sub-family of the finches.

Embez'ziement, in criminal law, consists in fraudulently removing and secreting personal property, with which the party has been intrusted, for the purpose of applying it to his own use. The moral guilt of embezzlement is often greater than that of larceny, and the laws against it are therefore justly severe.

Em'blem, specifically a picture representing one thing to the eye and another to the understanding. The most common emblems are such as a balance, which represents justice; a crown, an emblem of royalty; the serpent, of cunning; &c.

Em'blements, in law, the crops actually growing at any time upon land. They are considered in law as personal property, and pass as such to the executor or administrator of the occupier, if the latter die before he has actually cut, or reaped, or gathered the same.

Em'bolism, the blocking up of a blood-vessel by a clot of blood that comes from

some distance, till it reaches a vessel too small to permit its onward progress, often the cause of sudden paralysis and death, or of gangrene and pyæmia. See *Thrombosis*.

Embos'sing, the art of producing raised figures upon plane surfaces, such as on leather for bookbinding, &c.; on paper for envelopes, &c.; on wood or bronze, in architecture or sculpture.

Embra'cery, an attempt to corrupt or influence a jury by money, promises, letters, entertainments, persuasions, or the like.

Embra'sure, in fortification, an opening in the breastwork or parapet of a battery or fortress, to admit of a gun being fired through it.

Embrocation, a lotion or combination of medicinal liquids, with which any diseased part is rubbed or washed.

Embroid'ery, figured work in gold, or silver, or silk thread, wrought by the needle, upon cloths, stuffs, or muslins. In embroidering stuffs a kind of stretching frame is used, because the more the piece is stretched the easier it is worked. The art was common in the East in very ancient times. The Jews appear to have acquired it from the Egyptians; Homer makes frequent allusion to it; and Phrygia was celebrated for its embroidery, which was in great demand at Rome. The Anglo-Saxons had a continental reputation, and from the 11th to the 16th century the art of pictorial needlework was of the highest importance both as a recreation and as an industry. Embroidery is commonly divided into two classes: white embroidery applied to dress and furniture, in which the French and the Swiss excel; and embroidery in silk, gold, and silver, chiefly in demand for ecclesiastical vestments, &c. The Chinese, Hindus, Persians, and Turks excel in work of this kind.

Embrun (ân-brûn), a picturesque walled town, France, dep. Hautes-Alpes, on a rocky eminence on the Durance. It was sacked successively by Vandals, Huns, Saxons, and Moors, by the Protestants in 1573, and by the Duke of Savoy in 1692. It has a fine cathedral. Pop. 3957.

Em'bryo, (1) in zoology, the earliest and rudimentary form in which any young animal appears; it may be the first rudiments of the animal in the womb, before the several members are distinctly formed, after which it is called the *fœtus*. (See next article.) (2) In plants the embryo is the rudimentary organism contained in the seed.

Embryol'ogy, the branch of biology com-

prising the history of animals from the first appearance of organization in the egg or ovum (the embryo stage) up to the attainment of the perfect form. The importance of the study partly depends upon the fact that the history of animals thus traced reveals the existence of structures which disappear at a later period, or become obscured by arrest of their development, or by union with other parts, and permits us to follow the steps by which complex organs arise by the combination of simpler parts. Thus points of affinity are detected between species and orders whose adult aspect is very unlike. As a systematic study embryology dates only from the present century, though Aristotle and Galen had considered the subject, and though Harvey and other later physiologists did much in the way of direct observation to lay the foundations of higher work.

Em'den, a town of Prussia, province of Hanover, near the mouth of the Ems, occupying a low flat intersected by numerous canals. The principal building is the great church, built in 1455. The harbours, connected with the town by canals, are shallow. It exports grain, dairy produce, gin, &c., and has ship-building yards, and manufactures hosiery, leather, &c. Pop. 13,634.

Em'erald, a well-known gem of pure green colour, somewhat harder than quartz; sp. gravity 2.67 to 2.73. It is a silicate of aluminium and the rare element glucinum or beryllium, which was detected in it by Vauquelin after it had been discovered by the same chemist in the beryl. Its colour is due to the presence of chromium. Its natural form is either rounded or that of a short six-sided prism. It is one of the softest of the precious stones, but is not acted on by acids. Emeralds of large size and at the same time free from flaws are rare; the largest on record is said to have been possessed by the inhabitants of the valley of Manta in Peru when the Spaniards first arrived there. It was as big as an ostrich egg, and was worshipped as *the mother of emeralds*. The ancients, who valued them, especially for engraving, are said to have procured them from Ethiopia and Egypt. The finest are now obtained from Colombia. The oriental emerald is a variety of the ruby, of a green colour, and is an extremely rare gem. See *Beryl*.

Emerald Green, known also as SCHWEINFURTH GREEN, and by a great number of other names, a vivid light-green pigment,

prepared from arseniate of copper, and used both in oil and water-colour painting. It is extremely poisonous.

Em'erson, RALPH WALDO, an American poet and prose writer, born at Boston in 1803. He graduated at Harvard in 1821, for five years taught in a school, and in 1829 became minister to a Unitarian church in Boston, but in 1832 resigned his charge. He spent greater part of 1833 in Europe, and on his return began his career as a lecturer on various subjects, in which capa-



Ralph Waldo Emerson.

city he acted for a long series of years. In 1835 he took up his permanent residence at Concord, Mass., and in 1836 published a small volume called *Nature*. He was one of the original editors of the *Dial*, a transcendental magazine begun in 1840. Two volumes of his essays were published in 1841 and 1844, and his poems in 1846. His miscellaneous addresses had been published in England in 1844, and on visiting Great Britain in 1847 he was welcomed by a large circle of admirers. In 1850 he published *Representative Men*; in 1856, *English Traits*; in 1860, *The Conduct of Life*; in 1869, *May Day and Other Poems*, and *Society and Solitude*; in 1871, *Parnassus*, a collection of poems; in 1876, *Letters and Social Aims*. He died April 27, 1882. Emerson showed certain similarities with Carlyle, of whom he was a friend and correspondent. Their correspondence appeared in 1883. He was one of the most original and influential writers that the U. States have produced.

Em'ery, an impure variety of corundum, of blackish or bluish-gray colour, chiefly

found in shapeless masses and mixed with other minerals. It contains about 82 per cent of alumina, and a small portion of iron; is very hard; is infusible, and is not attacked by acids. The best emery is brought from the Levant, chiefly from Cape Emeri in Naxos. It also occurs in Spain, and in a few iron-mines in Great Britain. It is employed in cutting and polishing precious stones; in smoothing the surface of the finer kinds of lenses preparatory to their being polished; in the polishing of marble; by cutlers, locksmiths, glaziers, and other artisans. For all these purposes it is pulverized in large iron mortars or in steel mills, and the powder, which is rough and sharp, is carefully washed and sifted into eight or ten different degrees of fineness. Emery-paper and emery-cloth are made by laying a thin coat of glue upon the fabric, and dusting the emery from a sieve of the required size.

Em'sa, an ancient town, now called *Hems* (which see).

Emet'ic, any substance administered to induce vomiting. Emetics are most commonly administered to remove poisonous or indigestible substances from the stomach, or to clear the air-passages of obstructive morbid material in cases of bronchitis, croup, &c. Ipecacuanha and sulphate of zinc are frequently given for these purposes, or, as a readily obtainable substitute, mustard stirred into water. They should, however, always be administered with caution, or serious injury to the system may result.

Em'etine, a peculiar vegetable principle obtained from ipecacuanha root. In a dose of $\frac{1}{8}$ grain it acts as a powerful emetic, followed by sleep; in a dose of $\frac{1}{10}$ to $\frac{1}{5}$ grain it stimulates expectoration from the lungs.

Emeu, EMU (*ē'mū*), a large cursorial bird, *Dromaius Novæ Hollandiæ*, formerly dispersed over the whole Australian continent, but now almost extirpated in many districts. It is allied to the cassowary, but is distinguished by the absence of a 'helmet' on the top of the head. It nearly equals the ostrich in bulk, being thicker in the body, though its legs and neck are shorter. Its feet are three-toed (the ostrich has two toes), and its feathers, which are double, are of a dull sooty-brown colour, those about the neck and head being of a hairy texture. The wings are small and useless for flight, but the bird can run with great speed, and emeu coursing as a sport is said to surpass

that of the hare. The flesh of the young emeu is by some considered a delicacy. The emeu is a bird of the plain, the cassowary of the forest. It is easily tamed, and may be



Emeu (*Dromaius Novae Hollandiae*).

kept out of doors in temperate climates. It feeds on vegetable matter, fruits, roots, &c.

Emeu Wren (*Stipitūrus malachūrus*), a small Australian bird allied to the warblers, somewhat similar to a wren, but having the tail-feathers long, stiff, and thinly barbed, similar to emeu feathers.

Emigration, the departure of inhabitants from one country or state to another for the purpose of residence. The prime cause of such removal is over-population, though it is often influenced by particular and temporary incidents, such as an industrial crisis, a religious or political movement, the creation of a new colony, the desire to escape from laws regarded as oppressive or from compulsory military service. In barbarous times a tribe having exhausted the tract on which it had established itself, naturally migrated to more tempting territory. In Greece the limited territories of the states rendered the occasional deportation of part of the inhabitants to form new colonies a necessity; while at Rome, where the land was held by a few proprietors, and the trades and professions mainly exercised by slaves, the larger part of the free population had few sources of income apart from the occupation of portions of conquered territory in Italy and elsewhere. During the middle ages emigration was to some extent stayed by the fact that the feudal system confined the mass of the people to the soil or within the insuperable limits of a corporation. Emigration, in its proper sense, to America commenced with the departure of the Puritans who colonized New England; after which the Germans colonized

Pennsylvania, the Dutch New York, the Swedes Delaware, the French Canada and Louisiana. (See *Colony*.) Still the current of emigration was slow until 1815, when its rapid increase at first occasioned some alarm. Ultimately, however, acts forbidding emigration were either repealed or allowed to become obsolete, and towards the close of the period 1815-45 the annual emigration from Britain (only 2081 in 1815) had risen on three occasions to fully 100,000. In 1847 it rose to over a quarter of a million, while in the five years 1849-53 the average annual emigration was not less than 323,000. From the year 1855 the numbers diminished considerably, the annual average of the period 1855-59 being 134,304, and that of 1860-64 being only 127,779. Succeeding quinquennial periods, however, show, with the exception of the period 1875-79, a fairly steady increase, the numbers of the annual averages being: 1865-69, 165,283; 1870-74, 206,275; 1875-79, 124,503; 1880-84, 262,441. Of late years the higher numbers have been well maintained, the total for the year 1891 being 334,543, of whom 33,752 emigrants went to the N. American colonies, 252,016 to the United States, 19,957 to Australia and New Zealand, and 28,775 to other places. Against these numbers there must, of course, be set a large influx, every year, of immigrants from abroad, the number of these in 1891 being 151,360. Other European countries have also sent out large numbers of emigrants, especially Germany, the Scandinavian countries and Italy, Germany being second in numbers only to the U. Kingdom. The great bulk of the Germans go to the U. States. Many Italians have in recent years emigrated to the Argentine Republic.

Émigrés (ā-mi-grās), a name given more particularly to those persons who left France at the commencement of the first French revolution. At the head of these emigrants stood the royal princes of Condé, Provence, and Artois, the first of whom collected a part of the fugitives to co-operate with the allied armies in Germany for the restoration of the monarchy. At Coblenz a particular court of justice was established to settle causes relating to the French *émigrés*. The corps of Condé was finally taken into the Russian service, and was disbanded in the Russian-Austrian campaign of 1799. When Napoleon became emperor he granted permission to all but a few of the emigrants to return to their country; but many declined

to return until after his downfall. By the charter of 1814 they were shut out from the recovery of their estates and privileges.

Eminent Domain, the original ownership retained by the state, by which land or other private property may be taken for public use or benefit. If the authorities propose to set apart land for any lawful purpose, and the owner refuse to sell, or ask an unreasonable price, process may be issued from court to compel the surrender of the property. The constitution of the U. States limits the exercise of this right to cases where the public good demands it, and requires compensation to those from whom the property is taken.

Emin Pasha. See *Schnitzer, Edward*.

Emir (em'ēr), the title given by Mohammedans to independent chiefs or princes, *Amir* or *Ameer* being the same word. When associated with other words it denotes the heads of certain departments in Turkey. Thus the caliphs style themselves *Emir-al Mumenin*, Prince of the Faithful; *Emir-al Omrah*, Prince of Princes, is the title of the governors of the different provinces. The title is also given in Turkey to all the real or supposed descendants of Mohammed, through his daughter Fatimah.

Emmenagogues (em-men'a-gogz), medicines tending to promote menstruation.

Emmerich (em'e-rih), a walled town, Rhenish Prussia, on the right bank of the Rhine, 5 miles N.E. of Cleves. It carries on an active trade chiefly with Holland. Pop. 8900.

Em'met, ROBERT, an Irish rebel, born at Cork in 1780. He was expelled from Trinity College, Dublin, in 1798, on the ground of exciting disaffection and rebellion, and having become an object of suspicion to the government, quitted Ireland. He returned there on the repeal of the suspension of the Habeas Corpus Act, and became a member of the Society of United Irishmen for the establishment of the independence of Ireland. In July, 1803, he was the ringleader in the foolish rebellion in which Lord Kilwarden and others perished. He was arrested a few days afterwards, tried, and executed. His fate excited special interest from his attachment to Miss Sarah Curran, daughter of the celebrated barrister.

Emollients, medicines of an oleaginous, saponaceous, or emulsive character, applied to surfaces, generally external, to soothe and allay any tendencies to irritation or inflammation, &c.

Emotion, a term variously used by psychologists; sometimes as one of the divisions of feeling the other being sensation; sometimes as opposed to feeling when the latter is identified with sensation, and sometimes as distinct from both sensation and feeling, when the last term is rigidly confined to the sense of pleasure or pain. In any of these uses, however, emotions are distinguished from sensations in that sensations are primary forms of consciousness arising by external excitation, are comparatively simple and immediately presentative phenomena, and are definite in character and capable of localization; while emotions are secondary or derived forms of consciousness, are complex and representative, and are vague and diffused. Sensations are said to be 'peripherally initiated,' while emotions are centrally initiated. When, in addition to its being distinguished from sensation, it is also distinguished from feeling, emotion is applied to the whole psychical condition accompanying the sense of pleasure or pain (feeling). The muscles of the body and the organic functions of the system are often considerably influenced by emotion, which naturally seeks an outward expression unless held in check by what Darwin has called serviceable associated habits.

Empan'nel, to enter the names of the jurors into a schedule, roll, or page of a book, called the panel.

Emped'ocles (-klēz), a Greek philosopher of Agrigentum, in Sicily, born about 460 B.C. He is said to have introduced the democratic form of government in his native city, and the Agrigentines regarded him with the highest veneration as public benefactor, poet, orator, physician, prophet, and magician. Aristotle states that he died in obscurity, at the age of sixty years, in the Peloponnesus; but he is also said to have thrown himself into the crater of Mount Etna, in order to make it be believed, by his sudden disappearance, that he was of divine origin. According to Lucian, however, his sandals were thrown out from the volcano, and the manner of his death revealed. Empedocles holds earth, water, fire, air, as the four fundamental and indestructible elements from whose union and separation everything that exists is formed. To these material elements are added the two moving or operative principles of love and hatred, or attraction and repulsion.

Em'peror (from the Latin *imperātor*; in German, *Kaiser*, from *Cæsar*), the title of

the highest rank of sovereigns. The word *imperātor*, from *imperāre*, to command, in its most general sense signified the commander of an army. After the overthrow of the Roman republic *imperator* became the title of the rulers or emperors, and indicated their supreme power. Victorious generals were still, however, sometimes saluted with the title *imperator*, in its original sense. With the fall of Rome the title was lost in the West, but was kept up in the Eastern or Byzantine Empire for nearly ten centuries. In 800 it was renewed in the West when Charlemagne was crowned, by Leo III., as 'Carolus Augustus, the God-sent pious and great emperor of Rome.' It was, however, for many centuries considered necessary to be crowned at Rome, in order to be formally invested with the title of *emperor*. The imperial dignity became extinct in the East after the conquest of Constantinople in 1453, but the title was adopted by Peter I. of Russia in 1721. Napoleon I. adopted the old idea of an empire as a general union of states under the protection, or at least political preponderance, of one powerful state; and he was followed in this by his nephew, Napoleon III. In 1806 the first German Empire, 1000 years old, became extinct, and the German Emperor, Francis II., adopted the title of Francis I., emperor of Austria. In December, 1870, the second German Empire was formed, King William of Prussia having accepted the imperial office and title offered him at Versailles while engaged in the siege of Paris. Britain is considered as an empire, the crown as imperial, and the parliament is styled the *Imperial Parliament of Great Britain and Ireland*; but the sovereign has not the imperial title in reference to the home dominions, though the Queen bears the title of Empress of India. The sovereigns of China, Japan, and Morocco are often, though with little propriety, called *emperors*.

Emperor Moth (*Saturniapavonia minor*), a British moth of the silk-worm family. The colour is grayish-brown, with a faint purple tinge. The wings are about 3 inches in expanse, and in the centre of each is a large eye-like spot. The larva is of a green colour, with a black band on each segment.

Empetra'ceæ, a small nat. order of heath-like exogenous plants, of which the type is the crowberry.

Em'phasis, in rhetoric, a special stress or force given to some syllable, word, or words in speaking, in order to impress the hearers

in some desired manner, thus differing from *accent*, the position of which is fixed.

Empyse'ma, in medicine, an inflation of some part of the body by the introduction of air into the cellular tissue, as from an injury to the trachea or lungs.

Empire, the dominions of an emperor (which see).—*Empire State*, a name given to New York State, New York being called the *Empire City*.

Empir'ic, in medical history (from the Greek word *empeiria*, experience), an appellation assumed by a sect of physicians who contended that observation and experience alone were the foundation of the art of medicine. An empiric, in modern medicine, is a physician who has had no regular professional education, but who relies on what is frequently a very crude experience.

Employer's Liability Act, a British act of parliament passed in 1880, by which, within certain limits, an injured workman or, in event of his death, his relatives or representatives may claim from the employer compensation for injuries received in his service. Thus the employer is liable when the injury has been caused by any defect in the works, machinery, &c., by the negligence of a superintendent or any one with authority over the employé, by the negligence of any person in charge of railway signals, points, &c. An action must be brought within six months of the accident, or twelve months of the death, and notice of injury received must be given within six weeks. This act has been followed in the United States.

Em'poli, a town in North Italy, on the left bank of the Arno, 16 miles W.S.W. of Florence; has an old collegiate church with good paintings, and manufactures of straw bonnets, &c. Pop. 6500.

Empo'rium (Greek, *emporion*, a mart, from *emporos*, a merchant), a centre of extensive commerce, a trading town or city.

Empo'ria, Lyon co., Kan.; centre of a fine agricultural district. Pop. 7550.

Empye'ma, in medicine, a collection of pus or morbid matter in some cavity of the body, especially in the cavity of the pleura or chest.

Empyreu'ma, the smell arising from organic matter when subjected to the action of fire, but not enough to carbonize it entirely. The products of imperfect combustion, as from wood heated in heaps or distilled in close vessels, are frequently distinguished as *empyreumatic*.

Ems, a beautiful watering-place in the Prussian province of Hesse-Nassau, on the river Lahn, not far from its confluence with the Rhine. Its mineral waters are warm—from 70° to 118° Fahr., contain large quantities of carbonic acid gas, and are used in chronic catarrhs, pulmonary complaints, diseases of the stomach, gout, and some diseases of the urinary vessels. There are about 8000 visitors each season. Pop. 6943.

Ems, a river of North-west Germany, which flows north-west through Rhenish Prussia and Hanover, and falls into the Dollart Estuary near Emden; length 230 miles.

Emu. See *Emeu*.

Emul'sine, or SYNAPTASE, an albuminous or caseous substance of which the white part of both sweet and bitter almonds chiefly consists; discovered by Liebig and Wölder.

Emul'sion, a medical preparation, consisting of an oily or resinous substance made to combine with water by some substance that itself has the property of combining with both, such as gum arabic, the yolk of eggs, almonds, &c.

E'mys, a genus of tortoises, type of the family Emydidae, which includes the terrapins of America and others.

Enaliosau'rians ('sea-lizards'), a group of gigantic extinct reptiles of which the ichthyosaurus and plesiosaurus were the chief.

Enam'el, a vitreous glaze of various colours fused to the surface of gold, silver, copper, and other substances. The art of enamelling, which is of great antiquity, was practised by the Assyrians and by the Egyptians, from whom it may have passed into Greece, and thence into Rome and its provinces, including Great Britain, where various Roman antiquities with enamelled ornamentation have been discovered. The enamelled gold cup given by King John to the corporation of Lynn, in Norfolk, proves that the art was known among the Normans. The Byzantines of the 10th century produced excellent *cloisonné* enamels on a gold base, the *cloisonné* process consisting in tracing the design in fillets of gold upon the gold plate and filling up the small moulds thus formed with enamels the design appearing in coloured enamels separated by thin gold partitions or *cloisons*. In some cases, however, the enamels were filled into hollows beaten out in the gold plate, which formed part of the field. In the 12th century the town of Limoges acquired the high reputation for inlaid enamels which it held till the 14th century, and re-

acquired in the 16th for its painted enamels. The costliness of the sculptured ground had led the Italians early in the 14th century to substitute the practice of incising the design on the face of the plate, and then covering it with a transparent enamel. The further step, which made the Limousin workshops famous, consisted in the method of superficial enamelling, in which opaque colours or colours laid on a white opaque ground were used. The Limoges school degenerated greatly in the 17th century, but its method with certain modifications in detail is still employed. The basis of all kinds of enamel is a perfectly transparent and fusible glass, which is rendered either semitransparent or opaque by the admixture of metallic oxides. White enamels are composed by melting the oxide of tin with glass, and adding a small quantity of manganese or phosphate of calcium to increase the brilliancy of the colour. The addition of the oxide of lead, or antimony, or oxide of silver, produces a yellow enamel. Reds are formed by copper, and by an intermixture of the oxides of gold and iron. Greens, violets, and blues are formed from the oxides of copper, cobalt, and iron. In the middle of the last century enamelling was largely applied to the decoration of snuff-boxes, tea-canisters, candlesticks, and other small articles. Of late years it has been extensively applied to the coating of iron vessels for domestic purposes, the protection of the insides of baths, cisterns, and boilers, and the like. Enamelling in colours upon iron is now common, iron plates being thus treated by means of various mixtures, and words and designs of various kinds being permanently fixed upon them by stencilling, for advertising, signboards, &c.

Ena'ra, a lake of Russia, in the north of Finland, about 50 miles long by 30 miles broad. It is studded by innumerable islets, receives several streams, and is connected by the Patsjoki with the Arctic Ocean. At its south-west extremity is a small fishing town of same name, with an annual fair.

Enare'a, a region belonging to the country of the Gallas, south from Abyssinia. Sakha is the chief town. Coffee and ivory are the chief exports. The inhabitants are the most civilized of the Gallas.

Enarthro'sis, a ball-and-socket joint.

Encampment. See CAMP.

Encar'pus, in architecture, a sculptured ornament in imitation of a garland of fruits, leaves, or flowers, suspended between two

points. The garland is of greatest size in the middle, and diminishes gradually to the points of suspension, from which the ends generally hang down. The encarpus is some-

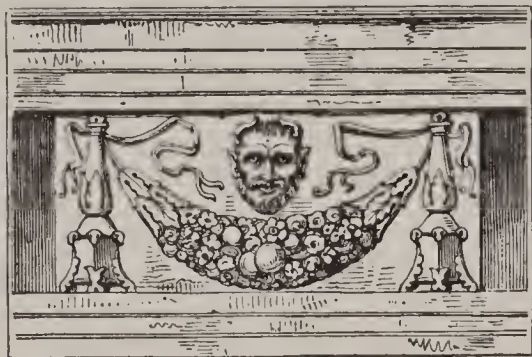

Encarpus, from Palazzo Niccolini, Rome.

times composed of an imitation of drapery similarly disposed, and sometimes of an assemblage of musical instruments, implements of war or of the chase.

Encaustic Painting, a kind of painting practised by the ancients, for the perfecting of which heating or burning in was required. Pliny distinguishes three species, in all of which wax was used along with colours. The art has been revived in modern times, but has not been greatly employed. As the thing chiefly regarded in encaustic painting was the securing of permanence and durability by the application of heat, the word *encaustic* has been applied to other and widely different processes. Thus it has been used for painting on earthen vessels, for painting on porcelain and work in enamel; and in the same way it was given to the painting on glass of the middle ages. See next article.

Encaustic Tiles, ornamental paving-tiles of baked pottery, much used during the middle ages in the pavements of churches and other ecclesiastical edifices. The encaustic tile, strictly so-called, was decorated with patterns formed by different coloured clays inlaid in the tile and fired with it. The art appears to have originated in the latter part of the 12th century, to have attained its highest perfection during the 13th, and to have sunk into disuse in the 15th. During the whole of this period it was principally carried on in England and Normandy. After a long lapse the art was revived in England in 1830 by Wright, a Shelton potter. In modern manufacture two methods are employed, the 'plastic' and the 'semi-dry' or 'dust' method. The first is, in all essentials, that used in the middle ages, except, perhaps, in the perfection of

modern moulding appliances; the second consists in ramming pulverized clay with a minimum of moisture into metal dies, the subsequent firing of tiles thus consolidated being attended with less risk from shrinkage.

Enceinte (ân-sant'), in fortification, the continuous line of works which forms the main inclosure of a town or fortress. The term is also applied to the area within this line.

Ence'nia, festivals anciently commemorative of the founding of a city or the dedication of a church; and in later times periodical ceremonies, as at Oxford, in commemoration of founders and benefactors.

Enceph'ala, that division of the Mollusca characterized by possessing a distinct head, and comprising the Gasteropoda, Pteropoda, and Cephalopoda.

Encephali'tis, inflammation of the brain.

Enceph'al'n, a term for the brain and whole nervous mass included in the skull.

Enchanter's Nightshade, a name common to plants of the genus *Circea*, nat. order Onagraceæ, two species being found in Britain, *C. lutetiāna* and *C. alpina*. The former is about a foot and a half high, and has delicate ovate leaves, small white flowers tinged with pink, and small roundish seed-vessels covered with hooked bristles. It abounds in shady woods. *C. alpina*, which is similar, but smaller and more delicate, is found in Scotland and north of England. Both species are found in the U. States.

Enchasing, the art of producing raised or indented ornamental figures and designs upon metallic surfaces. See *Chasing*.

Enchorial (en-kō'ri-al) **Writing**, the form of writing used by the old Egyptians for the common purposes of life, as distinct from the hieroglyphic and hieratic (used by the priests). Called also *Demotic*.

Encke (en'ke), JOHANN FRANZ, German astronomer, born at Hamburg in 1791. He studied under the astronomer Gauss at Göttingen. During the war of Liberation (1813-15) he served as artilleryman in the German army, and after the peace became assistant in the observatory of Seeberg, near Gotha. Here he calculated the orbit of the comet observed by Mechain, Miss Herschel, and Pons, predicted its return, and detected a gradual acceleration of movement, ascribed by him to the presence of a resisting medium. The comet is now known as Encke's comet. (See *Comets*.) The fame of his works *Die Entfernung der Sonne* (The Distance of the Sun) and *Der Venusdurchgang von 1769*

(Transit of Venus of 1769) led to his appointment as director of the Berlin Observatory (1825), a position which he held till his death in 1865.

Enclave (ân-kláv), a term used in German and French to denote a place or country which is entirely surrounded by the territories of another power. Thus several petty duchies and principalities are enclaves of Prussia.

En'crinite, a name often applied to all the marine animals of the order Crinoidea or stone-lilies, class Echinodermata, but more specifically restricted to the genera

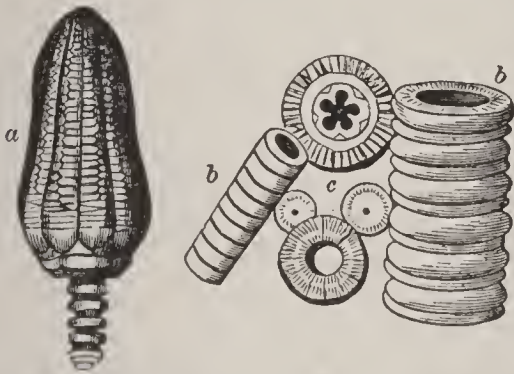

a, Fossil Encrinite with arms closed. bb, Portions of the Encrinite stem. c, Separate joints.

having rounded, smooth stems attached to the bottom, and supporting the body of the animal, which has numerous jointed arms radiating from a central disc, in which the mouth is situated. Encrinites were exceedingly numerous in past ages of the world's history; of those still existing our knowledge has been greatly increased of recent years through deep-sea dredging. Some of these forms are very graceful and interesting. See also *Crinoidea*.

Encyclopædia, **CYCLOPÆDIA**, or **CYCLOPEDIA** (Greek *en*, in, *kyklos*, a circle, and *paideia*, instruction), a systematic view of the whole extent of human knowledge or of particular departments of it, with the subjects arranged generally in alphabetic order. Varro and Pliny the elder, among the Romans, attempted works of an encyclopædic nature, the latter in his well-known *Historia Naturalis*, or Natural History. Other ancient encyclopedic works were those of Stobæus and Suidas, and especially of Marcianus Capella. In the 13th century a work on a regular plan was compiled by the Dominican Vincent of Beauvais (d. 1264), in which was exhibited the whole sum of the knowledge of the middle ages. His work was entitled *Speculum Historiale, Naturale, Doctrinale*, to which an anonymous author

added, some years later, a *Speculum Morale*. Roger Bacon's *Opus Majus* also belonged to the encyclopedic class. An exceedingly popular work was the *De Proprietatibus Rerum* of Bartholomeus de Glanvilla, an English Franciscan Friar, which maintained its reputation from 1360 to the middle of the 16th century. In the 17th century various encyclopedic works were compiled, such as the Latin one of Johann Heinrich Alsted (in 7 vols., Herborn, 1620). In 1674 appeared the first edition of Moreri's *Le Grand Dictionnaire Historique*; in 1677 Johann Jacob Hoffmann published at Basel his *Lexicon Universale*; and in 1697 appeared Bayle's famous *Dictionnaire Historique et Critique*, which is still of great value. The first English alphabetical encyclopædia was the *Lexicon Technicum*, published in 1704. Among the chief English works of this kind are: 1. Ephraim Chambers's *Cyclopædia, or a Universal Dictionary of Arts and Sciences*, published in 1728 in 2 vols. folio. 2. The *Encyclopædia Britannica*, published in Edinburgh, in nine editions—the first in 1788, the last in 1875–88 (24 vols. 4to, besides an index vol. 1889). 3. Rees' *Cyclopædia*, 39 vols. 4to, illustrated, 1802–20. 4. *Edinburgh Encyclopædia*, 1810–30, 18 vols. 4to, conducted by Sir David (then Dr.) Brewster. 5. *Encyclopædia Metropolitana*, London, 29 vols. 4to, and containing some valuable complete treatises. 6. The *London Encyclopædia*, by Thomas Curtis, 22 vols. 4to; London, 1829. 7. The *Penny Cyclopædia*, in 28 vols. small folio, 1833–43; since recast under the name of the *English Cyclopædia*. 8. Chambers's *Encyclopædia*, in 10 vols. large 8vo, 1860–68; new edition begun 1888. 9. The *Popular Encyclopædia*, in 7 vols. large 8vo, 1833–38; in 14 vols., 1882–85. The chief American encyclopædias are the *Encyclopædia Americana*, in 13 vols., 1829–33; the *New American Cyclopædia*, in 16 vols., 1858–63 and 1881, and Johnson's *Universal Cyclopedia*, 4 vols., 1874–77, and 8 vols., 1885. Of the French cyclopædias the most famous is the great *Dictionnaire Encyclopédique*, by Diderot and D'Alembert (see next article); the *Encyclopédie Méthodique*, ou par Ordre des Matières, Paris, 1781–1832, in 201 vols. 4to, of which 47 are plates; the *Encyclopédie Moderne*, 1824–32, 26 vols.; the *Encyclopédie des Gens du Monde*, 1835–44, 22 vols.; the *Dictionnaire de la Conversation et de la Lecture*, 1851–58 (2d edition), 16 vols. with supplements since; and the large and valuable *Grand Dictionnaire*

Universel du XIX Siècle, edited by Larousse, 16 vols. folio (with supplementary vols.). Numerous works of this kind have been published in Germany, the most popular being the Conversations-Lexikon of Brockhaus, now in its thirteenth edition; Meyer's Konversations-Lexikon, in its fourth edition; Pierer's Konversations-Lexikon, in its seventh edition; and that issued by Spamer, now in its second edition. The most comprehensive is the Allgemeine Encyklopädie, originally edited by Professors Ersch and Gruber, begun in 1818, and not yet completed.

Encyclopédie (ân-sik-lo-pā-dē), THE FRENCH, the most important work of the 18th century after the works of Voltaire and Rousseau, originated in a French translation of Ephraim Chambers's Cyclopædia. Diderot was appointed to edit it, and enlisted the ablest men of the time as contributors. D'Alembert (who wrote the famous Discours préliminaire) edited the mathematics; Rousseau wrote the musical articles; Daubenton, those connected with natural history; the Abbé Yvon, those on logic, metaphysics, and ethics; Toussaint, those on jurisprudence; Buffon contributed the article Nature; and Montesquieu, Voltaire, Euler, Marmon- tel, D'Holbach, Turgot, Grimm, and Con- dorcet took some share in the great work. Diderot himself was a prolific contributor on a wide variety of topics. The prospectus appeared in November, 1750, and the first volume in 1751, the whole being completed, despite fierce opposition, in 1765.

Endecagon, a plane figure of eleven sides and angles.

Endem'ic (Greek, *en*, and *dēmos*, people), a name commonly applied to diseases which attack the inhabitants of a particular district or country, and have their origin in some local cause, as the physical character of the place where they prevail, or in the employ- ments, habits, and mode of living of the people. Diseases which are endemic in one country may also appear in others, and be- come epidemic under influences resembling those which are the causes of the endemic in the former place.

En'derby Land, an island in the Antarctic Ocean, lon. 50° E., crossed by the Antarctic Circle.

En'dive, a plant, *Cichorium Endivia*, nat. order Compositæ, a native of Asia, intro- duced into Britain in 1548, and cultivated for culinary purposes. It has large sinuate, smooth, toothed, or finely-curved deep-green leaves, which, when blanched, are used in

salads, soups, &c. Chicory or succory is *C. Intybus*.

Endless Screw, a mechanical contrivance, consisting of a screw, the thread of which gears into a wheel with skew teeth, the ob- liquity corresponding to the angle of pitch of the screw. It is generally employed as a means of producing slow motion in the adjustments of machines, rather than as transmitter of any great amount of power.

Endlicher (end'li-hér), STEPHEN LADIS- LAUS, Austrian botanist, &c., born at Pres- burg in 1804. He was successively court- librarian at Vienna, and keeper of the natural history museum; and in 1840 was appointed professor of botany in the Uni- versity of Vienna, and director of the botanic garden, which he immediately be- gan to reorganize. He took part on the popu- lar side in the German revolution of 1848, and died by his own hand in 1849. Among his chief botanical works are his *Genera Plan- tarum*, a systematic treatise on botany; and his *Enchiridion Botanicum* or Manual of Botany.

Endocardi'tis, the inflammation of the endocardium or serous membrane covering the valves and internal surface of the heart.

Endog'amy (Greek, *endon*, within, *gamos*, marriage), a custom among some savage peoples of marrying only within their own tribe: opposite to *exogamy*.

Endogenous Plants (en-doj'e-nus), or EN- DOGENS (Gr. *endon*, within, *gen*, to produce),

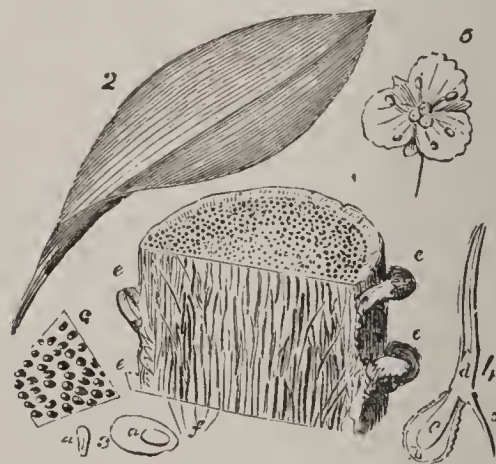

1, Section of the stem of a Palm: *c*, Portion of stem, natural size, showing the ends of the bundles of woody fibre; *e*, Remains of leaf-stalks; *f*, Bundles of woody fibre. 2, Endogenous Leaf, showing its parallel veins. 3, Mono- cotyledonous Seed, showing its single cotyledon: *a, a*, Co- tyledon. 4, Germination of Palm: *c*, Cotyledon; *b*, Albu- men; *d*, Plumule; *e*, Radicle issuing from a short sheath, endorhiza. 5, Flower of Endogen.

one of the large primary classes into which the vegetable kingdom is divided, so named in consequence of the new woody bundles being developed in the interior of the stem,

in which there is no distinction of pith and bark. In transverse section these bundles appear scattered through the cellular matter, being more compact towards the circumference. The other organs of the plants are also characteristic. The leaves are generally parallel-veined, the flowers usually with three organs in each whorl, the seed has an embryo with one cotyledon, and the radicle issues from a sheath and is never developed into a tap-root in germination. To this class belong palms, grasses, rushes, lilies, &c. Endogens increase in thickness only to a limited extent; hence they are not injured by twining plants as exogens are.

En'domorph, a term applied to minerals inclosed in crystals of other minerals.

En'doparasite (Greek, *endon*, within), a parasite living on the internal organs of animals, as opposed to an *ectoparasite*, which infests the skin.

Endorhiza (-rī'za), in botany, a term descriptive of the radicle of the embryo of monocotyledonous plants, which is developed inside a sheath (Gr. *endon*, within, *rhiza*, a root), from which it issues in germination. The cut shows the germinating embryo of the oat.



Endorhiza.

En'doskeleton, in anatomy, a term applied to the internal bony structure of man and other animals (Greek, *endon*, within), in contradistinction to *exoskeleton*, which is the outer and hardened covering of such animals as the crab, lobster, &c.

En'dosmose, or ENDOSMO'SIS, the transmission of fluids or gases through porous septa or partitions from the exterior to the interior of a vessel. An instrument for measuring the force of endosmotic action is known as an endosmometer.

En'dosperm, the tissue surrounding the embryo in many seeds and which is contained with it within the testa. It contains the supply of food for the germinating embryo, and is also called albumen or perisperm.

Endym'ion, a personage of Greek mythology, according to various accounts a huntsman, a shepherd, or a king of Elis, who is said to have asked of Zeus, or to have received as a punishment, eternal sleep. Others relate that Selēnē or Diana (the moon) conveyed him to Mount Latmos in Caria, and threw him into a perpetual sleep

in order that she might enjoy his kisses whenever she pleased.

Ene'ma, any liquid or gaseous form of medicine for injection into the rectum. It is most commonly administered to induce peristaltic action of the bowels, but it is often the most desirable means of conveying into the system nourishment or stimulants.

En'ergy, in physics, the power that a body or system possesses of doing work. A body may possess energy in one of two forms, viz. as *kinetic* energy, that is the energy due to motion, and *potential* energy, that is energy due to what may be called a position of advantage. Thus a moving mass, a bullet for example, can do work in virtue of its motion, and the name kinetic energy is given to energy of this kind. Under this name is also included energy belonging to molecular motion, to electricity in motion, to heat and light, and to actual chemical action. Again, as examples of potential energy we may take the case of a mass raised up to a position in which it is capable of doing work by falling—the weight of a clock for instance; but the term also includes the energy due to electrical separation, to absorbed heat, and to chemical separation, as in gunpowder, which is ready to do work by means of its explosion. From the investigations of Joule and others into the nature and phenomena of heat and the discovery of the equivalence of a definite quantity of mechanical energy to a definite quantity of heat, the grand principle of the *conservation of energy* was established. This asserts that the total amount of energy in the universe, or in any limited system which does not receive energy from without, or part with it to external matter, is invariable. If energy of any form seems to disappear in such a case it reappears in some other form. Thus, mechanical energy may be converted into heat. Heat again may be converted into the energy of electricity in motion, or into the potential energy of chemical separation. And electrical energy, whether potential or kinetic, and the energy of chemical separation, are also convertible into heat. (See also *Correlation of Physical Forces*.) Connected with this principle is another which states that no known natural process is *exactly* reversible, and that if we transform mechanical energy into heat, for example, we never can pass back and obtain from the heat produced precisely the amount of mechanical energy with which we commenced.

Whatever attempt is made to transform and retransform energy by an imperfect process, and no known process is perfect, *part of the energy is necessarily transformed into heat, and is dissipated* so as to be incapable of further useful transformation. It therefore follows, that as energy is in a constant state of transformation, there is a constant process of *degradation* of energy going on, a process by which energy constantly approaches the unavailable form of uniformly diffused heat; and *this will go on till the whole of the energy of the universe has taken this final form.*

Enfantin (ân-fân-tan), BARTHÉLEMY PROSPER, one of the chief apostles of St. Simonianism; born at Paris 1796. In 1825 he became acquainted with St. Simon, who in dying confided to him the task of continuing the work. This he did with success until after the revolution of 1830, when, as the representative of the social and religious theories of the school, he quarrelled with Bazard, the representative of its political ideas. Enfantin organized model communities, which quickly fell to pieces; the new organ of the sect, the *Globe*, was a failure; their convent at Ménilmontant, of which Enfantin was 'supreme father,' was broken up by government (1832). He himself was imprisoned as an offender against public morality (being an advocate of free love), and on his release attempted to found a model colony in Egypt, which was broken up in the second year. He then retired to Tain (Drôme), where he lived for some time as a farmer. In 1841 he was sent as member of a commission to explore the industrial resources of Algiers, and on his return published a work on the Colonization of Algiers (1848). On the revolution of 1848 he started a new journal, the *Crédit Public*, but after two years withdrew from public notice. He held latterly a post on the Lyons and Mediterranean Railway until his death in 1864.

En'field, a market town, England, county of Middlesex, 9 miles north by east of London. It is the seat of the government manufactory of rifles and small-arms. Pop. 31,532.

Enfield, Hartford co., Conn., chiefly a Shaker settlement. Pop. 1890, 7199. This includes the township, which is so closely settled as to constitute a town.

En'gadine, a beautiful valley in Switzerland, in the Grisons, on the banks of the Inn, bordering on the Tyrol, about 50 miles long, but in some parts very narrow, divided

into Upper and Lower. The pop. of the whole valley amounts to about 12,000. The language generally spoken is the Ladin, a branch of the Romanic tongue. The cold, dry climate and mineral springs have made the valley a favourite resort for invalids.

Engaged Column, in architecture, a column attached to a wall so that part of it (usually less than half) is concealed.

Engel (eng'l), KARL, a German writer on music; born in 1818, died in 1882 at London, where he had been settled for more than thirty years. He wrote *The Music of the Most Ancient Nations*; *An Introduction to the Study of National Music*; *Musical Myths and Facts*; &c.

Enghien (ân-gi ân), or ENGUIEN, a town in Hainault, Belgium, between Brussels and Tournai. It has a superb castle, and gave the title of duke to a prince of the house of Bourbon Condé in memory of the victory gained here by the great Condé. Pop. 4187.

Enghien (ân-gi-ân), LOUIS ANTOINE HENRI DE BOURBON, DUKE OF, born at Chantilly in 1772; son of Louis Henry Joseph Condé, duke of Bourbon. On the outbreak of the revolution he quitted France, travelled through various parts of Europe, and went in 1792 to Flanders to join his grandfather, the Prince of Condé, in the campaign against France. From 1796 to 1799 he commanded with distinguished merit the vanguard of Condé's army, which was disbanded at the Peace of Lunéville (1801). He then took up residence as a private citizen at Ettenheim in Baden, where he married the Princess Charlotte de Rohan Rochefort. He was generally looked upon as the leader of the *émigrés*, and was suspected by the Bonapartists of complicity in the attempt of Cadoudal to assassinate the first consul. An armed force was sent to seize him in Baden in violation of all territorial rights, and he was brought to Vincennes on the 20th March, 1804. A mock trial was held the same night; and on the following morning he was shot in the ditch outside the walls. It was this event which drew from Fouché the comment since become proverbial: 'C'est plus qu'un crime, c'est une faute' ('It is worse than a crime, it is a blunder').

En'gia, the modern name of Ægina (which see).

En'gine, a mechanical contrivance in which one or other of the natural forces is utilized for the performance of work of some kind; often distinctively a steam-engine.

Engineer', a term of somewhat loose application, being applied both to mechanics employed in the construction or management of steam-engines, and also to persons in general 'who make the useful application of mechanical science their peculiar study and profession;' the term *engineering* having a corresponding meaning. Those who turn their attention especially to the construction of docks, bridges, canals, light-houses, railroads, sewage and drainage, &c., are generally classed as *civil engineers*; those who devote themselves to the manufacture of machinery are known as *mechanical engineers*; while *mining engineers* are those who discover minerals and manage mines, &c. A distinct department from any of these is that of the *military engineer*. The special duties of the military engineer consist in the construction of fortifications, including the trenches and batteries required in besieging places; also of barracks and magazines, and of roads and bridges to facilitate the passage of an army. Civil engineering as a profession may be said to have originated in England about 1770, when the improvements of the steam-engine by Watt opened a new field for invention and adaptive skill. In 1818 the London Institution of Civil Engineers was founded, and the publication of its Transactions has been highly useful in disseminating data relating to the objects of the profession.

Engineers, ROYAL, a corps in the British army intrusted with the construction of all military works, plans, surveys, &c. The corps usually numbers from 5000 to 6000 officers and men. The privates are generally skilled artisans.

Engineers, CORPS OF, organized in the U. States in 1802. It is a special arm of the military service, charged with the selection and purchase of sites and the construction of fortifications; the removal of obstructions in streams; and important field duties in preparing for the movement of forces. It also plans and superintends harbour and river improvements, and makes surveys and geographical explorations. Until 1866 the engineer corps had the superintendence of the West Point academy; but since that year all branches of the service share in its supervision.

Engineers IN THE UNITED STATES NAVY are commissioned officers having charge of the machinery of steam-vessels. A thorough practical education in the construction and management of steam ma-

chinery is required. In military law they are considered non-combatants.

England, including WALES, the southern and larger portion of the island of Great Britain, is situated between 50° and 55° 46' N. lat., and 1° 46' E. and 5° 42' W. lon. On the N. it is bounded by Scotland; on all other sides it is washed by the sea; on the E. by the North Sea or German Ocean; on the S.

ENGLISH COUNTIES.	Area in sq. miles.	Pop. April 6, 1891.
Bedford,	461	160,729
Berks,	704	238,446
Buckingham,	730	185,190
Cambridge,	820	188,862
Chester,	1,102	730,052
Cornwall,	1,359	322,589
Cumberland,	1,516	266,550
Derby,	1,026	527,886
Devon,	2,586	631,767
Dorset,	980	194,487
Durham,	1,012	1,016,449
Essex,	1,648	785,399
Gloucester,	1,258	599,974
Hampshire,	1,611	690,086
Hereford,	832	115,986
Hertford,	611	220,125
Huntingdon,	359	57,772
Kent,	1,570	1,142,281
Lancaster,	1,888	3,926,798
Leicester,	800	373,693
Lincoln,	2,762	472,778
Middlesex,	283	3,251,703
Monmouth,	576	252,260
Norfolk,	2,119	456,474
Northampton,	984	302,184
Northumberland,	2,010	506,096
Nottingham,	822	445,599
Oxford,	734	185,938
Rutland,	149	20,659
Salop,	1,314	236,324
Somerset,	1,640	484,326
Stafford,	1,140	1,083,273
Suffolk,	1,484	369,351
Surrey,	786	1,730,871
Sussex,	1,450	550,442
Warwick,	885	805,070
Westmoreland,	783	66,098
Wilts,	1,343	264,969
Worcester,	738	413,755
York (East Riding),	1,257	399,412
— (North Riding),	2,120	368,237
— (West Riding),	2,682	2,441,164
WELSH COUNTIES.		
Anglesey,	302	50,079
Brecon,	719	57,031
Cardigan,	693	62,596
Carmarthen,	947	130,574
Carnarvon,	577	118,225
Denbigh,	613	117,950
Flint,	264	77,189
Glamorgan,	854	687,147
Merioneth,	602	49,204
Montgomery,	758	58,003
Pembroke,	616	89,125
Radnor,	432	21,791
Total of England and Wales,	58,311	29,001,018

ENGLAND.

by the English Channel; and on the w. by St. George's Channel and the Irish Sea. Its figure is, roughly speaking, triangular, but with many windings and indentations, the coast-line measuring not less than 2765 miles. The length of the country, measured on a meridian from Berwick nearly to St. Alban's Head, is 365 miles. Its breadth, measured on a parallel of latitude, attains its maximum between St. David's Head, in South Wales, and the Naze, in Essex, where it amounts to 280 miles. The area is 37,319,221 acres or 58,311 square miles, of which 32,597,398 acres or 50,933 square miles are in England, and 4,721,823 acres or 7378 square miles in Wales. This is exclusive of the Channel Islands and the Isle of Man, which together would add 193,647 acres or 302 square miles more to the area. The subdivision of England into counties is said to date from the time when the country was still under several kings, but it does not appear to have assumed a definite form till the time of Alfred the Great. The existing division was first completed in the time of Henry VIII. The names, areas, and population of the different counties are given in the adjoining table.

The capital of England and of the British Empire is London. The cities next in size (in order of population) are: Liverpool, Manchester and Salford, Birmingham, Leeds, Sheffield, Bristol, Nottingham, Bradford, and Hull.

Physical Features.—The chief indentations are: on the east, the Humber, the Wash, and the Thames estuary; on the west, the Solway Firth, Morecambe Bay, Cardigan Bay, and the Bristol Channel; those on the south are less prominent, though including some useful harbours. The greater part of the coast consists of cliffs, in some places clayey, in others rocky, and sometimes jutting out, as at Whitby and Flamborough Head on the east, Beachy Head, the Isle of Portland, the Lizard and Land's End on the south and south-west, St. David's Head and St. Bees Head on the west, into bold, lofty, and precipitous headlands. The most extensive stretches of flat coast are on the east, in the county of Lincoln, and from the southern part of Suffolk to the South Foreland in Kent, and in Sussex and Hants on the south coast. The chief islands are: Holy Island, the Farne Islands, Sheppy, and Thanet on the east coast; the Isle of Wight on the south; the Scilly Isles at the south-west extremity; and Lundy Island,

Anglesey, Holyhead, and Walney on the west.

The loftiest heights of England and Wales are situated at no great distance from its western shores, and consist, not so much of a continuous chain as of a succession of mountains and hills, stretching, with some interruptions, from north to south, and throwing out numerous branches on both sides, but particularly to the west, where all the culminating summits are found. The northern portion of this range has received the name of the Pennine chain. It is properly a continuation of the Cheviot Hills, and, commencing at the Scottish Border, proceeds south for about 270 miles till, in the counties of Derby and Stafford, it assumes the form of an elevated moorland plateau. In Derbyshire The Peak rises to the height of 2080 feet. By far the most important of its offsets are those of the west, more especially if we include in them the lofty mountain masses in North-western England sometimes classed separately as the Cumbrian range. Amidst these mountains lie the celebrated English lakes, of which the most important are Windermere, Derwent Water, Coniston Lake, and Ullswater. Here also is the highest summit of Northern England, Scawfell (3210 feet). The Pennine chain, with its appended Cumbrian range, is succeeded by one which surpasses both these in loftiness and extent, but has its great nucleus much further to the west, where it covers the greater part of Wales, deriving from this its name, the Cambrian range. Its principal ridge stretches through Carnarvonshire from N.N.E. to S.S.W., with Snowdon (3571 feet) as the culminating point of South Britain. Across the Bristol Channel from Wales is the Devonian range. It may be considered as commencing in the Mendip Hills of Somerset, and then pursuing a south-westerly direction through that county and the counties of Devon and Cornwall to the Land's End, the wild and desolate tract of Dartmoor forming one of its most remarkable features (highest summit, Yes Tor, 2050 feet). Other ranges are the Cotswold Hills proceeding in a north-easterly direction from near the Mendip Hills; the Chiltern Hills taking a similar direction farther to the east; and the North and South Downs running eastward, the latter reaching the south coast near Beachy Head, the former reaching the south-east coast at Folkestone.

Large part of the surface of England consists of wide valleys and plains. Be-

ginning in the north, the first valleys on the east side are those of the Coquet, Tyne, and Tees; on the west the beautiful valley of the Eden, which, at first hemmed in between the Cumbrian range and Pennine chain, gradually widens out into a plain of about 470 square miles, with the town of Carlisle in its centre. The most important of the northern plains is the Vale of York, which has an area of nearly 1000 square miles. Properly speaking it is still the same plain which stretches, with scarcely a single interruption, across the counties of Lincoln, Suffolk, and Essex, to the mouth of the Thames, and to a considerable distance inland, comprising the Central Plain and the region of the Fens. On the west side of the island, in S. Lancashire and Cheshire, is the fertile Cheshire Plain. In Wales there are no extensive plains, the valleys generally having a narrow rugged form favourable to romantic beauty, but not compatible with great fertility. Wales, however, by giving rise to the Severn, can justly claim part in the vale, or series of almost unrivalled vales, along which it pursues its romantic course through the counties of Montgomery, Salop, Worcester, and Gloucester. South-east of the Cotswold Hills is Salisbury Plain, but it is only in name that it can be classed with the other plains and level lands of England, being a large elevated plateau, of an oval shape, with a thin chalky soil only suitable for pasture. In the south-west the only vales deserving of notice are those of Taunton in Somerset and Exeter in Devon. A large portion of the south-east may be regarded as a continuous plain, consisting of what are called the Wealds of Sussex, Surrey, and Kent, between the North and South Downs, and containing an area of about 1000 square miles. The south-east angle of this district is occupied by the Romney Marsh, an extensive level tract composed for the most part of a rich marine deposit. Extensive tracts of a similar nature are situated on the east coast, in Yorkshire and Lincoln, where they are washed by the Humber; and in the counties which either border the Wash, or, like Northampton, Bedford, Huntingdon, and Cambridge, send their drainage into it by the Nen and the Ouse. Many of these lands are naturally the richest in the kingdom; but have only been utilized by means of drainage.

England is well supplied with rivers, many of them of great importance to industry and commerce. Most of them carry

their waters to the North Sea. If we consider the drainage as a whole, four principal river basins may be distinguished, those of the Thames, Wash, and Humber belonging to the German Ocean; and the Severn belonging to the Atlantic. The basin of the Thames has its greatest length from east to west, 130 miles, and its average breadth about 50 miles, area 6160 square miles. The river itself, which is the chief of English rivers, has a length of 215 miles. The basin of the Wash consists of the subordinate basins of the Great Ouse, Nen, Welland, and Witham, which all empty themselves into that estuary, and has an area computed at 5850 square miles. The basin of the Severn consists of two distinct portions, that on the right bank, of an irregularly oval shape, and having for its principal tributaries the Teme and the Wye; and that on the left, of which the Upper Avon is the principal tributary stream. The area of the whole basin is 8580 square miles. The next basin, that of the Humber, the largest of all, consists of the three basins of the Humber proper, the Ouse, and the Trent, and its area is 9550 square miles, being about one-sixth of the whole area of England and Wales. Other rivers unconnected with these systems are the Tyne, Wear, and Tees in the north-east; the Eden, Ribble, Mersey, and Dee in the north-west. The south-coast streams are very unimportant except for their estuaries.

In regard to the minerals, climate, agriculture, manufactures, &c., of England, see the article *Britain*.

Civil History.—The history of England proper begins when it ceased to be a Roman possession. (See *Britain*.) On the withdrawal of the Roman forces, about the beginning of the 5th century A.D., the South Britons, or inhabitants of what is now called England, were no longer able to withstand the attacks of their ferocious northern neighbours, the Scots and Picts. They applied for assistance to Attila, but the Roman general was too much occupied in the struggle with Attila to attend to their petition. In their distress they appear to have sought the aid of the Saxons; and according to the Anglo-Saxon narratives three ships, containing 1600 men, were despatched to their help under the command of the brothers Hengest and Horsa. Vortigern, a duke or prince of the Britons, assigned them the isle of Thanet for habitation, and, marching against the northern foe, they obtained

a complete victory. The date assigned to these events by the later Anglo-Saxon chronicles is 449 A.D., the narratives asserting further that the Saxons, finding the land desirable, turned their arms against the Britons, and, reinforced by new bands, conquered first Kent and ultimately the larger part of the island. Whatever the credibility of the story of Vortigern, it is certain that in the middle of the 5th century the occasional Teutonic incursions gave place to persistent invasion with a view to settlement. These Teutonic invaders were Low German tribes from the country about the mouths of the Elbe and the Weser, the three most prominent being the Angles, the Saxons, and the Jutes. Of these the Jutes were the first to form a settlement, taking possession of part of Kent, the Isle of Wight, &c.; but the larger conquests of the Saxons in the south and the Angles in the north gave to these tribes the leading place in the kingdom. The struggle continued 150 years, and at the end of that period the whole southern part of Britain, with the exception of Strathclyde, Wales, and West Wales (Cornwall), was in the hands of the Teutonic tribes. This conquered territory was divided among a number of small states or petty chieftaincies, seven of the most conspicuous of which are often spoken of as the *Heptarchy*. These were: 1. The kingdom of Kent; founded by Hengest in 455; ended in 823. 2. Kingdom of South Saxons, containing Sussex and Surrey; founded by Ella in 477; ended in 689. 3. Kingdom of East Angles, containing Norfolk, Suffolk, Cambridge, Ely (Isle of); founded by Uffa in 571 or 575; ended in 792. 4. Kingdom of West Saxons, containing Devon, Dorset, Somerset, Wilts, Hants, Berks, and part of Cornwall; founded by Cerdic 519; swallowed up the rest in 827. 5. Kingdom of Northumbria, containing York, Durham, Cumberland, Westmoreland, Northumberland, and the east coast of Scotland to the Firth of Forth; founded by Ida 547; absorbed by Wessex in 827. 6. Kingdom of East Saxons, containing Essex, Middlesex, Hertford (part); founded by Erchew in 527; ended in 823. 7. Kingdom of Mercia, containing Gloucester, Hereford, Worcester, Warwick, Leicester, Rutland, Northampton, Lincoln, Huntingdon, Bedford, Buckingham, Oxford, Stafford, Derby, Salop, Nottingham, Chester, Hertford (part); founded by Cridda about 584; absorbed by Wessex in 827. Each state was, in its turn,

annexed to more powerful neighbours; and at length, in 827, Egbert, by his valour and superior capacity, united in his own person the sovereignty of what had formerly been seven kingdoms, and the whole came to be called England, that is Angle-land.

While this work of conquest and of inter-tribal strife had been in progress towards the establishment of a united kingdom, certain important changes had occurred. The conquest had been the slow expulsion of a Christian race by a purely heathen race, and the country had returned to something of its old isolation with regard to the rest of Europe. But before the close of the 6th century Christianity had secured a footing in the south-east of the island. Ethelberht, king of Kent and suzerain over the kingdoms south of the Humber, married a Christian wife, Bertha, daughter of Charibert of Soissons, and this event indirectly led to the coming of St. Augustine. The conversion of Kent, Essex, and East Anglia was followed by that of Northumberland and then by that of Mercia, of Wessex, of Sussex, and lastly of Wight, the contest between the two religions being at its height in the seventh century. The legal and political changes immediately consequent upon the adoption of Christianity were not great, but there resulted a more intimate relation with Europe and the older civilizations, the introduction of new learning and culture, the formation of a written literature, and the fusion of the tribes and petty kingdoms into a closer and more lasting unity than that which could have been otherwise secured.

The kingdom, however, was still kept in a state of disturbance by the attacks of the Danes, who had made repeated incursions during the whole of the Saxon period, and about half a century after the unification of the kingdom became for the moment masters of nearly the whole of England. But the genius of Alfred the Great, who had ascended the throne in 871, speedily reversed matters by the defeat of the Danes at Ethandune (878). Guthrum, their king, embraced Christianity, became the vassal of the Saxon king, and retired to a strip of land on the east coast including Northumbria and called the Danelagh. The two immediate successors of Alfred, Edward (901-925) and Athelstan (925-940), the son and the grandson of Alfred, both vigorous and able rulers, had each in turn to direct his arms against these settlers of the Danelagh. The reigns of the next five kings, Edmund, Edred, Edwy, Edgar, and

Edward the Martyr, are chiefly remarkable on account of the conspicuous place occupied in them by Dunstan, who was counsellor to Edmund, minister of Edred, treasurer under Edwy, and supreme during the reigns of Edgar and his successor. It was possibly due to his policy that from the time of Athelstan till after the death of Edward the Martyr (978 or 979) the country had comparative rest from the Danes. During the 10th century many changes had taken place in the Teutonic constitution. Feudalism was already taking root; the king's authority had increased; the folkland was being taken over as the king's personal property; the nobles by birth, or ealdormen, were becoming of less importance in administration than the nobility of thegns, the officers of the king's court. Ethelred (978-1016), who succeeded Edward, was a minor, the government was feebly conducted, and no united action being taken against the Danes, their incursions became more frequent and destructive. Animositities between the English and the Danes who had settled among them became daily more violent, and a general massacre of the latter took place in 1002. The following year Sweyn invaded the kingdom with a powerful army and assumed the crown of England. Ethelred was compelled to take refuge in Normandy; and though he afterwards returned, he found in Canute an adversary no less formidable than Sweyn. Ethelred left his kingdom in 1016 to his son Edmund, who displayed great valour, but was compelled to divide his kingdom with Canute; and when he was assassinated in 1017 the Danes succeeded to the sovereignty of the whole.

Canute (Knut), who espoused the widow of Ethelred, that he might reconcile his new subjects, obtained the name of Great, not only on account of his personal qualities, but from the extent of his dominions, being master of Denmark and Norway as well as England. In 1035 he died, and in England was followed by other two Danish kings, Harold and Hardicanute, whose joint reigns lasted till 1042, after which the English line was again restored in the person of Edward the Confessor. Edward was a weak prince, and in the latter years of his reign had far less real power than his brother-in-law Harold, son of the great earl Godwin. On Edward's death in 1066 Harold accordingly obtained the crown. He found, however, a formidable opponent in the second-cousin

of Edward, William of Normandy, who instigated the Danes to invade the northern counties, while he, with 60,000 men, landed in the south. Harold vanquished the Danes, and hastening southwards met the Normans near Hastings, at Senlac, afterwards called Battle. Harold and his two brothers fell (Oct. 14, 1066), and William (1066-87) immediately claimed the government as lawful king of England, being subsequently known as William I., the Conqueror. For some time he conducted the government with great moderation; but being obliged to reward those who had assisted him, he bestowed the chief offices of government upon Normans, and divided among them a great part of the country. The revolts of the native English which followed were quickly crushed, continental feudalism in a modified form was established, and the English Church reorganized under Lanfranc as Archbishop of Canterbury.

At his death, in 1087, William II., commonly known by the name of Rufus, the conqueror's second son, obtained the crown, Robert, the eldest son, receiving the duchy of Normandy. In 1100, when William II. was accidentally killed in the New Forest, Robert was again cheated of his throne by his younger brother Henry (Henry I.), who in 1106 even wrested from him the duchy of Normandy. Henry's power being secured, he entered into a dispute with Anselm the primate, and with the pope, concerning the right of granting investiture to the clergy. He supported his quarrel with firmness, and brought it to a not unfavourable issue. His reign was also marked by the suppression of the greater Norman nobles in England, whose power (like that of many continental feudatories) threatened to overshadow that of the king, and by the substitution of a class of lesser nobles. In 1135 he died in Normandy, leaving behind him only a daughter, Matilda.

By the will of Henry I. his daughter Maud or Matilda, wife of Geoffrey Plantagenet, Count of Anjou, and frequently styled the Empress Matilda, because she had first been married to Henry V., emperor of Germany, was declared his successor. But Stephen, son of the Count of Blois, and of Adela, daughter of William the Conqueror, raised an army in Normandy, landed in England, and declared himself king. After years of civil war and bloodshed an amicable arrangement was brought about, by which it was agreed that Stephen should continue to reign

during the remainder of his life, but that he should be succeeded by Henry, son of Matilda and the Count of Anjou. Stephen died in 1154, and Henry Plantagenet ascended the throne with the title of Henry II., being the first of the Plantagenet or Angevin kings. A larger dominion was united under his sway than had been held by any previous sovereign of England, for at the time when he became King of England he was already in the possession of Anjou, Normandy, and Aquitaine.

Henry II. found far less difficulty in restraining the license of his barons than in abridging the exorbitant privileges of the clergy, who claimed exemption not only from the taxes of the state, but also from its penal enactments, and who were supported in their demands by the primate Becket. The king's wishes were formulated in the Constitutions of Clarendon (1164), which were at first accepted and then repudiated by the primate. The assassination of Becket, however, placed the king at a disadvantage in the struggle, and after his conquest of Ireland (1171) he submitted to the church, and did penance at Becket's tomb. Henry was the first who placed the common people of England in a situation which led to their having a share in the government. The system of frank-pledge was revived, trial by jury was instituted by the Assize of Clarendon, and the Eyre courts were made permanent by the Assize of Nottingham. To curb the power of the nobles he granted charters to towns, freeing them from all subjection to any but himself, thus laying the foundation of a new order in society.

Richard I., called Cœur de Lion, who in 1189 succeeded to his father, Henry II., spent most of his reign away from England. Having gone to Palestine to join in the third crusade he proved himself an intrepid soldier. Returning homewards in disguise through Germany, he was made prisoner by Leopold, duke of Austria, but was ransomed by his subjects. In the meantime John, his brother, had aspired to the crown, and hoped, by the assistance of the French, to exclude Richard from his right. Richard's presence for a time restored matters to some appearance of order; but having undertaken an expedition against France, he received a mortal wound at the siege of Chalons, in 1199.

John was at once recognized as King of England, and secured possession of Nor-

mandy; but Anjou, Maine, and Touraine acknowledged the claim of Arthur, son of Geoffrey, second son of Henry II. On the death of Arthur, while in John's power, these four French provinces were at once lost to England. John's opposition to the pope in electing a successor to the see of Canterbury in 1205 led to the kingdom being placed under an interdict; and the nation being in a disturbed condition, he was at last compelled to receive Stephen Langton as archbishop, and to accept his kingdom as a fief of the papacy (1213). His exactions and misgovernment had equally embroiled him with the nobles. In 1213 they refused to follow him to France, and on his return defeated, they at once took measures to secure their own privileges and abridge the prerogatives of the crown. King and barons met at Runnymede, and on June 15, 1215, the Great Charter (Magna Charta) was signed. It was speedily declared null and void by the pope, and war broke out between John and the barons, who were aided by the French king. In 1216, however, John died, and his turbulent reign was succeeded by the almost equally turbulent reign of Henry III.

During the first years of the reign of Henry III. the abilities of the Earl of Pembroke, who was regent until 1219, retained the kingdom in tranquillity; but when, in 1227, Henry assumed the reins of government he showed himself incapable of managing them. The Charter was three times reissued in a modified form, and new privileges were added to it, but the king took no pains to observe its provisions. The struggle, long maintained in the great council (henceforward called Parliament) over money grants and other grievances reached an acute stage in 1263, when civil war broke out. Simon de Montfort who had laid the foundations of the House of Commons by summoning representatives of the shire communities to the Mad Parliament of 1258, had by this time engrossed the sole power. He defeated the king and his son Edward at Lewes in 1264, and in his famous parliament of 1265 still further widened the privileges of the people by summoning to it burgesses as well as knights of the shire. The escape of Prince Edward, however, was followed by the battle of Evesham (1265), at which Earl Simon was defeated and slain, and the rest of the reign was undisturbed.

On the death of Henry III., in 1272, Edward I. succeeded without opposition. From 1276 to 1284 he was largely occupied in the conquest and annexation of Wales, which had become practically independent during the barons' wars. In 1292 Balliol, whom Edward had decided to be rightful heir to the Scottish throne, did homage for the fief to the English king; but when, in 1294, war broke out with France, Scotland also declared war. The Scots were defeated at Dunbar (1296), and the country placed under an English regent; but the revolt under Wallace (1297) was followed by that of Bruce (1306), and the Scots remained unsubdued. The reign of Edward was distinguished by many legal and legislative reforms, such as the separation of the old king's court into the Court of Exchequer, Court of King's Bench, and Court of Common Pleas, the passage of the Statute of Mortmain, &c. In 1295 the first perfect parliament was summoned, the clergy and barons by special writ, the commons by writ to the sheriffs directing the election of two knights from each shire, two citizens from each city, two burghers from each borough. Two years later the imposition of taxation without consent of parliament was forbidden by a special act (*De Tallagio non Concedendo*). The great aim of Edward, however, to include England, Scotland, and Wales in one kingdom proved a failure, and he died in 1307 marching against Robert Bruce.

The reign of his son Edward II. was unfortunate to himself and to his kingdom. He made a feeble attempt to carry out his father's last and earnest request to prosecute the war with Scotland, but the English were almost constantly unfortunate; and at length, at Bannockburn (1314), they received a defeat from Robert Bruce which ensured the independence of Scotland. The king soon proved incapable of regulating the lawless conduct of his barons; and his wife, a woman of bold, intriguing disposition, joined in the confederacy against him, which resulted in his imprisonment and death in 1327.

The reign of Edward III. was as brilliant as that of his father had been the reverse. The main projects of the third Edward were directed against France, the crown of which he claimed in 1328 in virtue of his mother, the daughter of King Philip. The victory won by the Black Prince at Crecy (1346), the capture of Calais (1347), and the victory of Poitiers (1356), ultimately led to the Peace

of Brétigny in 1360, by which Edward III. received all the west of France on condition of renouncing his claim to the French throne. (See *Brétigny*.) Before the close of his reign, however, these advantages were all lost again, save a few principal towns on the coast.

Edward III. was succeeded in 1377 by his grandson Richard II., son of Edward the Black Prince. The people of England now began to show, though in a turbulent manner, that they had acquired just notions of government. In 1380 an unjust and oppressive poll-tax brought their grievances to a head, and 100,000 men, under Wat Tyler, marched towards London (1381). Wat Tyler was killed while conferring with the king, and the prudence and courage of Richard appeased the insurgents. Despite his conduct on this occasion Richard was deficient in the vigour necessary to curb the lawlessness of the nobles. In 1398 he banished his cousin, Henry Bolingbroke; and on the death of the latter's father, the Duke of Lancaster, unjustly appropriated his cousin's patrimony. To avenge the injustice Bolingbroke landed in England during the king's absence in Ireland, and at the head of 60,000 malcontents compelled Richard to surrender. He was confined in the Tower, and despite the superior claims of Edmund Mortimer, Earl of March, Henry was appointed king (1399), the first of the House of Lancaster. Richard was, in all probability, murdered early in 1400.

The manner in which the Duke of Lancaster, now Henry IV., acquired the crown rendered his reign extremely turbulent, but the vigour of his administration quelled every insurrection. The most important—that of the Percies of Northumberland, Owen Glendower, and Douglas of Scotland—was crushed by the battle of Shrewsbury (1403). During the reign of Henry IV. the clergy of England first began the practice of burning heretics under the act *de hæretico comburendo*, passed in the second year of his reign. The act was chiefly directed against the Lollards, as the followers of Wickliffe now came to be called. Henry died in 1413, leaving his crown to his son, Henry V., who revived the claim of Edward III. to the throne of France in 1415, and invaded that country at the head of 30,000 men. The disjointed councils of the French rendered their country an easy prey; the victory of Agincourt was gained in 1415; and

ENGLAND.

after a second campaign a peace was concluded at Troyes in 1420, by which Henry received the hand of Katherine, daughter of Charles VI., was appointed regent of France during the reign of his father-in-law, and declared heir to the throne on his death. The two kings, however, died within a few weeks of each other in 1422, and the infant son of Henry thus became king of England (as Henry VI.) and France at the age of nine months.

England during the reign of Henry VI. was subjected, in the first place, to all the confusion incident to a long minority, and afterwards to all the misery of a civil war. Henry allowed himself to be managed by any one who had the courage to assume the conduct of his affairs, and the influence of his wife, Margaret of Anjou, a woman of uncommon capacity, was of no advantage either to himself or the realm. In France (1422-53) the English forces lost ground, and were finally expelled by the celebrated Joan of Arc, Calais alone being retained. The rebellion of Jack Cade in 1450 was suppressed, only to be succeeded by more serious trouble. In that year Richard, duke of York, the father of Edward, afterwards Edward IV., began to advance his pretensions to the throne, which had been so long usurped by the house of Lancaster. His claim was founded on his descent from the third son of Edward III., Lionel, duke of Clarence, who was his great-great-grandfather on the mother's side, while Henry was the great-grandson on the father's side of John of Gaunt, duke of Lancaster, the fourth son of Edward III. Richard of York was also grandson on the father's side of Edmund, fifth son of Edward III. The wars which resulted, called the Wars of the Roses, from the fact that a red rose was the badge of the house of Lancaster and a white one that of the house of York, lasted for thirty years, from the first battle of St. Albans, May 22, 1455, to the battle of Bosworth, Aug. 22, 1485. Henry VI. was twice driven from the throne (in 1461 and 1471) by Edward of York, whose father had previously been killed in battle in 1460. Edward of York reigned as Edward IV. from 1461 till his death in 1483, with a brief interval in 1471; and was succeeded by two other sovereigns of the house of York, first his son Edward V., who reigned for eleven weeks in 1483; and then by his brother Richard III., who reigned from 1483 till 1485, when he was defeated and slain

on Bosworth field by Henry Tudor, of the House of Lancaster, who then became Henry VII.

Henry VII. was at this time the representative of the house of Lancaster, and in order at once to strengthen his own title, and to put an end to the rivalry between the houses of York and Lancaster, he married in 1486 Elizabeth, the sister of Edward V. and heiress of the house of York. His reign was disturbed by insurrections attending the impostures of Lambert Simnel (1487), who pretended to be a son of the Duke of Clarence, brother of Edward IV., and of Perkin Warbeck (1488), who affirmed that he was the Duke of York, younger brother of Edward V.; but neither of these attained any magnitude. The king's worst fault was the avarice which led him to employ in schemes of extortion such instruments as Empson and Dudley. His administration throughout did much to increase the royal power and to establish order and prosperity. He died in 1509.

The authority of the English crown, which had been so much extended by Henry VII., was by his son Henry VIII. exerted in a tyrannical and capricious manner. The most important event of the reign was undoubtedly the Reformation; though it had its origin rather in Henry's caprice and in the casual situation of his private affairs than in his conviction of the necessity of a reformation in religion, or in the solidity of reasoning employed by the reformers. Henry had been espoused to Catharine of Spain, who was first married to his elder brother Arthur, a prince who died young. Henry became disgusted with his queen, and enamoured of one of her maids of honour, Anne Boleyn. He had recourse, therefore, to the pope to dissolve a marriage which had at first been rendered legal only by a dispensation from the pontiff; but failing in his desires he broke away entirely from the Holy See, and in 1534 got himself recognized by act of parliament as the head of the English Church. He died in 1547. He was married six times, and left three children, each of whom reigned in turn. These were: Mary, by his first wife, Catharine of Aragon; Elizabeth, by his second wife, Anne Boleyn; and Edward, by his third wife, Jane Seymour.

Edward, who reigned first, with the title of Edward VI., was nine years of age at the time of his succession, and died in 1553, when he was only sixteen. His short reign, or rather the reign of the Earl of Hertford,

afterwards Duke of Somerset, who was appointed regent, was distinguished chiefly by the success which attended the measures of the reformers, who acquired great part of the power formerly engrossed by the Catholics. The intrigues of Dudley, duke of Northumberland, during the reign of Edward, caused Lady Jane Grey to be declared his successor; but her reign, if it could be called such, lasted only a few days. Mary, daughter of Henry VIII., was placed upon the throne, and Lady Jane Grey and her husband were both executed. Mary, a bigoted Catholic, seems to have wished for the crown only for the purpose of re-establishing the Roman Catholic faith. Political motives had induced Philip of Spain to accept of her as a spouse; but she could never prevail on her subjects to allow him any share of power. She died in 1558.

Elizabeth, who succeeded her sister Mary, was attached to the Protestant faith, and found little difficulty in establishing it in England. Having concluded peace with France (1559), Elizabeth set herself to promote the confusion which prevailed in Scotland, to which her cousin Mary had returned from France as queen in 1561. In this she was so far successful that Mary placed herself in her power (1568), and after many years' imprisonment was sent to the scaffold (1587). As the most powerful Protestant nation, and as a rival to Spain in the New World, it was natural that England should become involved in difficulties with that country. The dispersion of the Armada by the English fleet under Howard, Drake, and Hawkins was the most brilliant event of a struggle which abounded in minor feats of valour. In Elizabeth's reign London became the centre of the world's trade, the extension of British commercial enterprise being coincident with the ruin of Antwerp in 1585. The parliament was increased by the creation of sixty-two new boroughs, and its members were exempted from arrest. In literature not less than in politics and in commerce the same full life displayed itself, and England began definitely to assume the characteristics which distinguish her from the other European nations of to-day.

To Elizabeth succeeded (in 1603) James VI. of Scotland and I. of England, son of Mary Queen of Scots and Darnley. His accession to the crown of England in addition to that of Scotland did much to unite the two nations, though a certain smoulder-

ing animosity still lingered. His dissimulation, however, ended in his satisfying neither of the contending ecclesiastical parties—the Puritans or the Catholics; and his absurd insistence on his divine right made his reign a continuous struggle between the prerogative of the crown and the freedom of the people. His extravagance kept him in constant disputes with the parliament, who would not grant him the sums he demanded, and compelled him to resort to monopolies, loans, benevolences, and other illegal methods. The nation at large, however, continued to prosper through the whole of this inglorious reign. His son Charles I., who succeeded him in 1625, inherited the same exalted ideas of royal prerogative, and his marriage with a Catholic, his arbitrary rule, and illegal methods of raising money, provoked bitter hostility. Under the guidance of Laud and Strafford things went from bad to worse. Civil war broke out in 1642 between the king's party and that of the parliament, and the latter proving victorious, in 1649 the king was beheaded.

A commonwealth or republican government was now established, in which the most prominent figure was Oliver Cromwell. Mutinies in the army among Fifth-monarchists and Levellers were subdued by Cromwell and Fairfax, and Cromwell in a series of masterly movements subjugated Ireland and gained the important battles of Dunbar and Worcester. At sea Blake had destroyed the Royalist fleet under Rupert, and was engaged in an honourable struggle with the Dutch under Van Tromp. But within the governing body matters had come to a deadlock. A dissolution was necessary, yet parliament shrank from dissolving itself, and in the meantime the reform of the law, a settlement with regard to the church, and other important matters remained untouched. In April, 1653, Cromwell cut the knot by forcibly ejecting the members and putting the keys of the house in his pocket. From this time he was practically head of the government, which was vested in a council of thirteen. A parliament—the Little or Barebones Parliament—was summoned, and in the December of the same year Cromwell was installed Lord Protector of the Commonwealth of England, Scotland, and Ireland. With more than the power of a king, he succeeded in dominating the confusion at home and made the country feared throughout the whole of Europe. Cromwell

died in 1658, and the brief and feeble protectorate of his son Richard followed.

There was now a wide-spread feeling that the country would be better under the old form of government, and Charles II., son of Charles I., was called to the throne by the Restoration of 1660. He took complete advantage of the popular reaction from the narrowness and intolerance of Puritanism, and even latterly endeavoured to carry it to the extreme of establishing the Catholic religion. The promises of religious freedom made by him before the Restoration in the Declaration of Breda were broken by the Test and Corporation Acts, and by the Act of Uniformity, which drove two thousand clergymen from the church and created the great dissenting movement of modern times. The Conventicle and Five-mile Acts followed, and the 'Drunken Parliament' restored Episcopacy in Scotland. At one time even civil war seemed again imminent. The abolition of the censorship of the press (1679) and the re-affirmation of the Habeas Corpus principle are the most praiseworthy incidents of the reign.

As Charles II. left no legitimate issue, his brother the Duke of York succeeded him as James II. (1685-88). An invasion by an illegitimate son of Charles, the Duke of Monmouth, who claimed the throne, was suppressed, and the king's arbitrary rule was supported by the wholesale butcheries of such instruments as Kirke and Jeffreys. The king's zealous countenance of Roman Catholicism and his attempts to force the church and the universities to submission provoked a storm of opposition. Seven prelates were brought to trial for seditious libel, but were acquitted amidst general rejoicings. The whole nation was prepared to welcome any deliverance, and in 1688 William of Orange, husband of James's daughter Mary, landed in Torbay. James fled to France, and a convention summoned by William settled the crown upon him, he thus becoming William III. Annexed to this settlement was a Declaration of Rights circumscribing the royal prerogative by depriving him of the right to exercise dispensing power, or to exact money, or maintain an army without the assent of parliament. This placed henceforward the right of the British sovereign to the throne upon a purely statutory basis. A toleration act, passed in 1689, released dissent from many penalties. An armed oppo-

sition to William lasted for a short time in Scotland, but ceased with the fall of Viscount Dundee, the leader of James's adherents; and though the struggle was prolonged in Ireland, it was brought to a close before the end of 1691. The following year saw the origination of the national debt, the exchequer having been drained by the heavy military expenditure. A bill for triennial parliaments was passed in 1694, the year in which Queen Mary died. For a moment after her death William's popularity was in danger, but his successes at Namur and elsewhere, and the obvious exhaustion of France, once more confirmed his power. The treaty of Ryswick followed in 1697, and the death of James II. in exile in 1701 removed a not unimportant source of danger. Early in the following year William also died, and by the act of settlement Anne succeeded him.

The closing act of William's reign had been the formation of the grand alliance between England, Holland, and the German Empire, and the new queen's rule opened with the brilliant successes of Marlborough at Blenheim (1704) and Ramilies (1706). Throughout the earlier part of her reign the Marlboroughs practically ruled the kingdom, the duke's wife, Sarah Jennings, being the queen's most intimate friend and adviser. In 1707 the history of England becomes the history of Britain, the Act of Union passed in that year binding the parliaments and realms of England and Scotland into a single and more powerful whole. See art. *Britain*.

Ecclesiastical History.—The first religion of the Celts of England was Druidism. It has been conjectured that Christianity may have reached Britain by way of France (Gaul) before the conclusion of the 1st, or not long after the commencement of the 2d century, but the period and manner of its introduction are uncertain. It had, however, made considerable progress in the island previous to the time of Constantine the Great (306-337). Several bishops from Britain sat in the Councils of Nice (325), Sardica (347), and Ariminum, in Italy (359); and in 519 an ecclesiastical synod of all the British clergy was held by St. David, archbishop of Caerleon and uncle of King Arthur, for extirpating the remains of the Pelagian heresy.

A period of almost total eclipse followed the inroad of the pagan Saxons, and it was not till A.D. 570 that signs of change showed themselves in the new nationality. On the

coming of Austin, or St. Augustine, sent over in 596 by Gregory the Great, a residence at Canterbury was assigned to him, and Ethelberht, king of Kent, and most of his subjects, adopted Christianity. Other missionaries followed; East Saxons were soon after converted by Mellitus; and a bishop's see was established at London, their capital, early in the 7th century. The Northumbrians were next converted, an event accelerated by the marriage of their king, Edwin, with a daughter of Ethelberht, and by the labours of the missionary Paulinus. The influence of Edwin and Paulinus also secured the conversion of Carpwald, king of the East Angles; and as a reward to Paulinus, Edwin erected a see at York, and obtained an archbishop's pall for him from Pope Honorius I., who sent one at the same time to Canterbury. The conversion of the other kingdoms followed in the course of the 7th century.

As Kent and Wessex received Christianity from Roman and Frankish missionaries, and Mercia and Northumbria through the Scottish Culdees (for Northumbria had apostatized after the death of its first Christian king, and received Christianity anew from a Scottish source), there were certain differences between the churches, especially concerning the time of keeping Easter. To promote the union of the churches thus founded in England with the Church of Rome, a grand council was summoned by Theodore of Tarsus, archbishop of Canterbury, at Hertford, A.D. 673, when uniformity was secured among all the English churches, and the see of Canterbury made supreme.

The clergy in course of time attained, particularly after the Norman conquest, to such a height of domination as to form an *imperium in imperio*. Under Anselm (1093-1109) the church was practically emancipated from the control of the state, and the power of the pope became supreme. The result was a considerable increase of monasticism in England, and the prevalence of the greatest abuses under the cloak of church privilege. Several monarchs showed themselves restive under the papal control, but without shaking off the yoke; and though Henry II. succeeded in abating some evils, yet the severity of the penance exacted from him for the murder of Becket is a striking proof of the power that the church then had in punishing offences committed against itself. The reaction set in during the reign of Henry III., when the vigorous indepen-

dence of Robert Grosseteste did much to stimulate the individual life of the English church. With the reign of Edward I. the new system of parliaments came as an effective rival of the church synods, and various acts restrained the power of the clergy. In the 14th century the teaching of Wickliffe promised to produce a thorough revolt from Rome; but the difficulties of the house of Lancaster, which drove its members to propitiate the church, and the Wars of the Roses, prevented matters coming to a head.

A steady decay of vital power set in, however, and when Henry VIII. resolved to recast the English church there was no effective protest. In 1531 the convocation of the clergy addressed a petition to Henry VIII. as the chief protector and only and supreme lord of the English Church. Not very long after the parliament abolished appeals to the see of Rome, dispensations, licenses, bulls of institution for bishoprics and archbishoprics, the payment of Peter's-pence, and the annates. In 1534 the papal authority was set aside by act of parliament, and by another act of parliament, passed in 1535, Henry assumed the title of supreme head of the Church of England. These acts, although they severed the connection between the English Church and the holy see, did not alter the religious faith of the church. But under Edward VI. the Duke of Somerset, the protector of the realm during the minority of the king, caused a more thorough reform of the doctrines and ceremonies of the church to be made. At his instigation parliament in 1547 repealed the statute of the six articles promulgated by Henry VIII., and in 1551 a new confession of faith was embodied in forty-two articles, denying the infallibility of councils, keeping only two sacraments, baptism and the Lord's supper, and rejecting the real presence, the invocation of saints, prayer for the dead, purgatory, and the celibacy of the clergy. At the same time a new liturgy was composed, in which English was substituted for Latin.

With the reign of Mary the old religion was re-established; and it was not till that of Elizabeth that the Church of England was finally instituted in its present form. The doctrines of the church were again modified, and the forty-two articles were reduced to thirty-nine by the convocation of the clergy in 1563. As no change was made in the episcopal form of government, and some rites and ceremonies were re-

tained which many of the reformed considered as superstitious, this circumstance gave rise to many future dissensions. In 1559, before the close of the first year of Elizabeth's reign, the Acts of Supremacy and Uniformity were passed with the object of bringing about the entire subjection of the church and the people in religious matters to the royal authority.

From James I. some relief was anticipated by Puritans and nonconformists, but they were disappointed. Under Charles I. the attempt was made, through the instrumentality of Laud, to reduce all the churches of Great Britain under the jurisdiction of bishops. But after the death of Laud the parliament abolished the episcopal government, and condemned everything contrary to the doctrine, worship, and discipline of the Church of Geneva. As soon as Charles II. was restored the ancient forms of ecclesiastical government and public worship were re-established and three severe measures were passed against nonconformity, namely, the Corporation Act of 1661, the Act of Uniformity, passed in 1662, and the Test Act, passed in 1673 (see *Act of Uniformity, Corporation and Test Acts*). In the reign of William III., and particularly in 1689, the divisions among the friends of Episcopacy gave rise to the two parties called the *high-churchmen* or *non-jurors*, and *low-churchmen*. The former maintained the doctrine of passive obedience to the sovereign; that the hereditary succession to the throne is of divine institution; that the church is subject to the jurisdiction of God alone; &c. The gradual progress of civil and religious liberty since that time has settled practically many such controversies. The great increase of the Dissenters in recent times (they are not much less numerous than the members of the Established Church) has led to new concessions in their favour, and especially to the repeal of the Corporation and Test Acts (in 1828), the Catholic emancipation (in 1829), and the opening of the universities in England to Dissenters (1871).

As at present constituted the established religion of England is Episcopacy. The sovereign is the supreme head. The church is governed by two archbishops and thirty-one bishops. The Archbishop of Canterbury is styled the *primate of all England*, and to him belongs the privilege of crowning the kings and queens of England. The province of Canterbury comprehends 24 bishoprics; in the province of the Archbishop of York,

who is styled *primate of England*, there are 9 bishoprics, the province comprising Cheshire, Lancashire, Yorkshire, and the other northern counties. Archbishops and bishops are appointed by the sovereign by what is called a *congé d'élire*, or leave to elect, naming the person to be chosen and sent to the dean and chapter. The archbishops and bishops, to the number of 24, have seats in the House of Lords, and are styled spiritual lords. The following are the bishops' sees:—London, Durham, Winchester, Bangor, Bath and Wells, Carlisle, Chester, Chichester, Gloster and Bristol, Hereford, Lichfield, Liverpool, Llandaff, Newcastle, Norwich, Oxford, Peterborough, Rochester, St. Albans, St. Asaph, St. David's, Southwell, Truro, Worcester, Sodor and Man, Ripon, Exeter, Lincoln, Salisbury, Ely, Manchester, Wakefield. (See also *Archbishop and Bishop*.) To every cathedral belong several prebendaries and a dean; these together, spoken of as 'the dean and chapter,' form the council of the bishop. Subordinate to the bishops are a certain number of archdeacons. The most numerous and laborious of the clergy are the priests, whether curates, vicars, or rectors. A parson is a priest in full possession of all the rights of a parish church; if the great tithes are *impropriated* the priest is called a vicar; if not, a rector; a curate is one who exercises the spiritual office under a rector or vicar. The doctrines of the Church of England are contained in the Thirty-nine Articles; the form of worship is directed by the liturgy contained in the Book of Common Prayer. The total revenue of the church is about £7,000,000 annually. The clergy numbers about 23,000.

English Art.—As regards *architecture* little can be said with regard to the style prevalent between the invasion of the Anglo-Saxons and the Norman Conquest, from the fact that the remains of buildings erected in England before the Conquest are few and insignificant. The Norman style was introduced in the reign of Edward the Confessor, though the workmen, both then and after the Conquest, being English, the earlier work preserved many native characteristics. The Norman period proper extends from about 1090 to 1150, some of the best examples being parts of the cathedrals of Rochester, Winchester, Durham, and Canterbury. In the brief period 1160 to 1195 a marked change took place in the adoption of the pointed arch and what is known as the *Early English style*. Improved methods of con-

struction led to the use of lighter walls and pillars instead of the heavy masses employed in the Norman style. Narrow lancet-shaped windows took the place of the round arch; bold projecting buttresses were introduced; and the roofs and spires became more lofty and more pointed, while in the interiors pointed arches rested on lofty clustered pillars. The best Early English type is Salisbury Cathedral. The Early English style has been regarded as lasting from 1190 to 1270, when the *Decorated style* of Gothic began to prevail. The transition to the Decorated style was gradual, but it may be considered as lasting to 1377. Exeter Cathedral is an excellent example of the earliest Decorated style. Between 1360 and 1399 the Decorated style gave place to the *Perpendicular*, which prevailed from 1377 to 1547, and was an exclusively English style. Gothic architecture, though it lingered on in many districts, practically came to an end in England in the reign of Henry VIII. The *Elizabethan and Jacobean styles* which followed were transitions from the Gothic to the Italian, with which these styles were more or less freely mixed. Many palatial mansions were built in these styles. In the reign of Charles I. Inigo Jones designed, among other buildings, Whitehall Palace and Greenwich Hospital in a purely classic style. After the great fire in London (1666) Sir Christopher Wren designed an immense number of churches and other buildings in classic style, particularly St. Paul's Cathedral, the Sheldonian Theatre of Oxford, Chelsea Hospital, &c. Various phases of classic or Renaissance continued to prevail during the 18th and earlier part of the 19th century. About 1836 the Gothic revival commenced, and that style has been employed with considerable success in the churches erected in recent times. The Houses of Parliament, erected in 1840-60 in the Tudor style, the Law Courts of Salford, St. Pancras railway-station, and the Law Courts of London (opened 1882) in the Gothic served to sustain an impetus that had been given to the use of that style. At the present day Gothic is much employed for ecclesiastical and collegiate buildings, and a mild type of Renaissance for civil buildings. Of late years a style that has received the name of 'Queen Anne' is much in vogue for private residences. It is very mixed, but withal highly picturesque. The most striking novelties in the 19th century have been induced by the extensive use of

iron and glass, as exemplified in the Exhibition building of 1851, the Crystal Palace, Sydenham, and the great railway-stations.

Very little is known of the state of the art of *painting* among the Anglo-Saxons; but in the 9th century Alfred the Great caused numerous MSS. to be adorned with miniatures, and about the end of the 10th century Archbishop Dunstan won reputation as a miniature painter. Under William the Conqueror and his two sons the painting of large pictures began to be studied, and Lanfranc, archbishop of Canterbury, adorned the vault of his church with paintings. Numerous miniatures of the 13th and 14th centuries have come down to us, rude in execution, but not without originality. From this period down to the 18th century a succession of foreign painters resided in England, of whom the chief were Mabuse, Hans Holbein, Federigo Zuccherro, Cornelius Jansen, Vandyck, Lely, and Kneller. Of native artists few are of importance prior to that original genius William Hogarth (1697-1764). Throughout the 18th century English artists attained higher eminence in portrait-painting than in other departments, and it culminated in Sir Joshua Reynolds (1723-92), Thomas Gainsborough (1727-88), and Romney (1734-1802). These were followed by Raeburn (1756-1823) and Lawrence (1769-1830). Barry (1741-1806), West (1738-1820), and Copley (1737-1815) gained distinction in historical compositions, especially in pictures of battles. Landscape-painting was represented by Richard Wilson, 1714-82, who painted classical scenes with figures from heathen mythology, and by Gainsborough already mentioned, who painted scenes of English nature and humble life. The Royal Academy of Arts, of which Reynolds was the first president, was established in London in 1769. Sir David Wilkie (1785-1841), in what is known abroad as *genre* painting has gained a European reputation that is unsurpassed. In the same class of art C. R. Leslie (1794-1859), Newton (1795-1835), Collins (1788-1847), Mulready (1786-1863), gained great distinction. In landscape the reputation of Turner (1775-1857) 'stands alone, solitary, colossal' (Wornum). Other distinguished landscape-painters are Clarkson Stanfield (1798-1867); David Roberts (1796-1864), who greatly excelled in picturesque architecture; Wm. Müller (1812-45); and John Constable (1776-1837); whose

works exercised great influence in France; and Calcott (1799–1844). In historical painting Hilton (1786–1839), Eastlake (1793–1865), Etty (1787–1849), E. M. Ward (1816–79), C. W. Cope (b. 1811), and D. Maclise (1811–70) attained celebrity. John Philip (1817–67) greatly distinguished himself by his scenes from Spanish life and by his mastery in colour. Landseer (1802–73) stands by himself as a painter of animals.

In 1824 the nucleus of the National Gallery was formed by the purchase of the Angerstein collection, and in 1832 the vote was passed for the erection of the National Gallery building. The competitions held in Westminster Hall in 1843, 1844, and 1847, with a view to the decoration of the Houses of Parliament, exercised great influence on art. Up to this time English pictures were rather distinguished for colour and effect of light and shade than for carefulness of modelling and exactness of drawing. In aiding to bring about a more accurate and careful style of work, the Pre-Raphaelites (1840–60), while seeking to restore in their practice an early phase of Italian art, exercised a beneficial influence, while they themselves ultimately abandoned the style to which at the first they had been devoted.

The modern group of British painters may be held to date from about 1850. Prominent among these the following may be named:—In historical painting Leighton, Alma-Tadema, Watts, Poynter, Long, Goodall, Holman Hunt, Noel Paton, Burne-Jones, and Madox Brown, as also W. P. Frith, whose *Derby Day* and *Railway Station*, so descriptive of modern life, may well be classed as historical. In figure painting or *genre* T. Faed, Erskine Nicol, Fildes, Orchardson, Herkomer, and Pettie. In portraiture Millais, Frank Holl, Oules, and Richmond. In landscape Linnell, Hook, Peter Graham, John Brett, Vicat Cole, H. Moore, and Keeley Halswelle. In water-colours the most eminent artists have been Girtin (1773–1802), Cotman (1782–1842), Liverseege (1803–32), Stothard (1755–1834), Turner, David Cox (1788–1859), De Wint (1784–1849), Copley Fielding (1787–1855), Barret (1774–1842), Samuel Prout (1783–1852), W. H. Hunt (1790–1864), Louis Haghe (1806–85), W. L. Leitch (1804–83), Sam Bough (1822–78), J. F. Lewis (1805–76).

English *sculpture* was long merely an accessory to architecture, and few English sculptors are known by name till comparatively modern times. During the Renais-

sance period Torregiano came from Italy and executed two masterpieces in England, the tomb of the mother of Henry VII., and that of Henry himself at Westminster. The troubles of the reign of Charles I. and the Commonwealth produced a stagnation in the art, and were the cause of the destruction of many valuable works. After the Restoration two sculptors of some note appeared, Grinling Gibbons, a wood-carver, and Caius Gabriel Cibber. During the 18th century there was no English sculptor of great eminence till John Flaxman (1755–1826). He had for rival and successor Sir Francis Chantrey (1781–1841), who acquired renown by the busts and statues which he made of many of the eminent men of his time. John Carew, Sir Richard Westmacott (1775–1856), E. H. Baily (1788–1867), John Gibson (1790–1866), P. MacDowell (1799–1870), H. Weekes (1807–77), and J. H. Foley (1818–74), are a few of the eminent sculptors of the 19th century. W. H. Thornycroft, J. E. Boehm, E. Onslow Ford, C. B. Birch, and Alfred Gilbert are among the foremost sculptors of the present time. The sculptures of the English school in general are characterized by a sort of romantic grace which is their distinguishing mark, and by extraordinary delicacy and finish in detail; but they frequently exhibit weakness in the modelling of naked parts, especially in female figures.

English Language.—The language spoken in England from the settlement of the Anglo-Saxons to the Norman Conquest (say 500–1066) is popularly known as Anglo-Saxon, though simply the earliest form of English. (See *Anglo-Saxons*.) It was a highly inflected and purely Teutonic tongue presenting several dialects. The Conquest introduced the Norman-French, and from 1066 to about 1250 two languages were spoken, the native English speaking their own language, the intruders speaking French. During this period the grammatical structure of the native language was greatly broken up, inflexions fell away, or were assimilated to each other; and towards the end of the period we find a few works written in a language resembling the English of our own day in grammar, but differing from it by being purely Saxon or Teutonic in vocabulary. Finally, the two languages began to mingle, and form one intelligible to the whole population, Normans as well as English, this change being marked by a great infusion of Norman-French words, and English proper

being the result. English is thus, in its vocabulary, a composite language, deriving part of its stock of words from a Teutonic source and part from a Latin source, Norman-French being in the main merely a modified form of Latin. In its grammatical structure and general character, however, English is entirely Teutonic, and is classed with Dutch and Gothic among the Low German tongues. If we divide the history of the English language into periods we shall find three most distinctly marked: 1st, the Old English or Anglo-Saxon, extending down to about 1100; 2d, the Middle English, 1100–1400 (to this period belong Chaucer, Wicliffe, Langland); 3d, Modern English. A more detailed subdivision would give transition periods connecting the main ones. The chief change which the language has experienced during the modern period consists in its absorbing new words from all quarters in obedience to the requirements of advancing science, more complicated social relations, and increased subtlety of thought. At the present time the rapid growth of the sciences already existing, and the creation of new ones, have caused whole groups of words to be introduced, chiefly from the Greek.

English Literature.—Before any English literature, in the strict sense of the term, existed, four literatures had arisen in England—the Celtic, Latin, Anglo-Saxon, and Anglo-Norman. The first includes such names as those of Taliesin, Llywarch Hen, Aneurin, and Merlin or Merddhin. The Latin literature prior to the Conquest presents those of Aldhelm, Bede, Alcuin, Asser, Ethelwerd, and Nennius. For Anglo-Saxon literature see the article *Anglo-Saxons*. With the coming of the Normans, although the Anglo-Saxon Chronicle was continued until 1154, the native language practically ceased for a time to be employed in literature, Latin being employed in law, history, and philosophy, French in the lighter forms of literature. The Norman *trouvère* displaced the Saxon *scop*, or gleeman, introducing the *Fabliau* and the Romance. By the *Fabliau* the literature was not greatly influenced until the time of Chaucer; but the Romance attained an early and striking development in the Arthurian cycle, founded upon the legends of Geoffrey of Monmouth's Latin History of the Britons (1147), by Geoffrey Gaimar, Maistre Wace, Walter Map, and other writers of the 12th century. The Latin literature included important contri-

butions to the Scholastic philosophy by Alexander Hales (d. 1245), Duns Scotus (d. 1308), and William of Occam (d. 1347), the philosophic works of Roger Bacon (1214–92), the Goliard poems of Walter Map, and a long list of chronicles or histories, either in prose or verse, by Eadmer (d. 1124), Ordericus Vitalis (d. 1142), William of Malmesbury (d. 1143), Geoffrey of Monmouth (d. 1154), Henry of Huntingdon (d. after 1154), Joseph of Exeter (d. 1195), Gervase of Tilbury (12th cent.), Roger of Wendover (d. 1237), Roger de Hoveden (12th and 13th cents.), Giraldus Cambrensis (d. 1222), Joscelin de Brakelonde (12th and 13th cents.), and Matthew Paris (d. 1259).

Apart from a few brief fragments, the first English writings after the Conquest are the Brut of Layamon (about 1200), based on the Brut of Wace; and the Ormulum, a collection of metrical homilies attributed to Orm or Ormin, an Augustine monk. Next in importance come the rhyming chroniclers Robert of Gloucester (time of Henry III. Edward I.) and Robert of Brunne or Mannyng (d. 1340), other writers being Dan Michel of Northgate (Ayenbite of Inwyt, 1340); Richard Rolle of Hampole (Pricke of Conscience, 1340); Laurence Minot (author of eleven military ballads; d. 1352); and several works of uncertain authorship, including the Ancren Riwele (? Richard Poor, d. 1237), Dialogue between the Owl and the Nightingale (? Nicholas of Guildford), the Land of Cockayne (? Michael of Kildare), the Song against the King of Almaine, and a Dialogue between the Body and the Soul. To this pre-Chaucerian period belong also several English translations of French romances—Horn, Tristrem, Alisaunder, Havelok, and others. Between the beginning and middle of the 14th century the English speech had entered upon a new phase of development in the absorption of Norman-French words. A rapid expansion of the literature followed, having as the foremost figure that of Chaucer (1340–1400), who, writing at first under French influences, and then under Italian, became in the end the most representative English writer of the time. Contemporary with him were the poets William or Robert Langland (1332–1400), John Gower (1325–1408), John Barbour (1316–95). In prose the name of John Wicliffe (1324–84) is pre-eminent, the English version of Mandeville's Travels being apparently of later date.

The period from the time of Chaucer to

ENGLAND.

the appearance of Spenser, that is, from the end of the 14th to near the end of the 16th century, is a very barren one in English literature, in part probably owing to foreign and domestic wars, the struggle of the people towards political power, and the religious controversies preceding and attending the Reformation. The immediate successors of Chaucer, Occleve (1370-1454) and Lydgate (d. 1460), were neither men of genius, and the centre of poetic creation was for the time transferred to Scotland, where James I. (1394-1437) headed the list which comprises Andrew de Wyntoun (15th cent.), Henry the Minstrel or Blind Harry (d. after 1492), Robert Henryson (d. before 1508), William Dunbar (1460-15—), Gavin Douglas (1474-1522), and Sir David Lyndsay (1490-1557). In England the literature was chiefly polemical, the only noteworthy prose prior to that of More being that of Reginald Pecock (1390-1460), Sir John Fortescue (1395-1485), the Paston Letters (1422-1505), and Malory's *Morte Darthur* (completed 1469-70); the only noteworthy verse, that of John Skelton (1460-1529).

It was now that several events of European importance combined to stimulate life and enlarge the mental horizon—the invention of printing, or rather of movable types, the promulgation of the Copernican system of astronomy, the discovery of America, the Renaissance, and the Reformation. The Renaissance spread from Florence to England by means of such men as Colet, Linacre, Erasmus, and Sir Thomas More (1480-1535), the last noteworthy as at the head of a new race of historians. Important contributions to the prose of the time were the Tyndale New Testament, printed in 1525, and the Coverdale Bible (1535). The first signs of an artistic advance in poetic literature are to be found in Wyatt (1503-42) and Surrey (1516-47), who nationalized the sonnet, and of whom the latter is regarded as the introducer of blank verse. The drama, too, had by this time reached a fairly high stage of development. The mystery and miracle plays, after the adoption of the vernacular in the 14th century, passed from the hands of the clergy into those of the laity, and both stage and drama underwent a rapid secularization. The morality began to embody matters of religious and political controversy, historical characters mingled with the personification of abstract qualities, real characters from contemporary life were in-

roduced, and at length farces on the French model were constructed, the Interludes of John Heywood (d. 1565) being the most important examples. To Nicholas Udall (1504-56) the first genuine comedy, *Roister Doister*, was due, this being shortly afterwards followed by John Still's *Gammer Gurton's Needle* (1566). The first tragedy, the *Ferrex and Porrex*, or *Gorboduc* of Sackville (d. 1608) and Norton (d. 1600), was performed in 1561, and the first prose play, the *Supposes of Gascoigne* (d. 1577) in 1566. *Gascoigne* and *Sackville* were in other regards than drama noteworthy amongst the earlier Elizabethans; but the figures which bulk most largely are those of Sidney (1554-86) and Spenser (1552-99). In drama Lyly, Peele, Greene, Nash, and Marlowe (1564-93) are the chief immediate precursors of Shakspeare (1564-1606), Marlowe alone, however, being at all comparable with the great master. Contemporary and later dramatic writers were Ben Jonson (1573-1637), the second great Elizabethan dramatist, Middleton (d. 1627), Marston (better known as a satirist), Chapman (1557-1634), Thomas Heywood, Dekker (d. 1639), Webster (17th cent.), Ford (1586-1639), Beaumont (1586-1616) and Fletcher (1576-1625), and Massinger (1584-1640). The minor poets include Michael Drayton (1563-1631), Samuel Daniel (1562-1619), John Davies (1570-1626), John Donne (1573-1631), Giles Fletcher (1580-1623), and Phineas Fletcher (1584-1650), Drummond of Hawthornden (1585-1649). In Elizabethan prose the prominent names are those of Roger Ascham (1515-68), Lyly the Euphuist (1553-1606), Hooker (1554-1600), Raleigh (1552-1618), Bacon (1561-1626), the founder in some regards of modern scientific method, Burton (1576-1640), Herbert of Cherbury (1581-1648), and Selden (1584-1654), with Overbury, Knolles, Holinshed, Stowe, Camden, Florio, and North. The issue of the authorized version of the Bible in 1611 may be said to close the prose list of the period.

After the death of James I. the course of literature breaks up into three stages, the first from 1625 to 1640, in which the survivals from the Elizabethan age slowly die away. The 'metaphysical poets,' Cowley, Wither, Herbert, Crashaw, Habbington, and Quarles, and the cavalier poets, Suckling, Carew, Denham, all published poems before the close of this period, in which also Milton's early poems were com-

ENGLAND.

posed, and the *Comus* and *Lycidas* published. The second stage (1640-60) was almost wholly given up to controversial prose, the Puritan revolution checking the production of pure literature. In this controversial prose of the time Milton was easily chief. With the restoration a third stage was begun. Milton turned his new leisure to the composition of his great poems; the drama was revived, and Davenant and Dryden, with Otway, Southerne, Etherege, Wycherley, Congreve, Vanbrugh, and Farquhar in their first plays, and minor playwrights, are the most representative writers of the period. Butler established a *genre* in satire, and Marvell as a satirist in some respects anticipated Swift; Roscommon, Rochester, and Dorset contributed to the little poetry; while in prose we have Hobbes, Clarendon, Fuller, Sir Thomas Browne, Walton, Cotton, Pepys and Evelyn, John Bunyan, Locke, Sir William Temple, Owen Feltham, Sir Henry Wotton, James Harrington, and a crowd of theological writers, of whom the best known are Jeremy Taylor ('Spenser of prose' and 'Shakspeare of divines'), Richard Baxter, Robert Barclay, William Penn, George Fox, Isaac Barrow, John Tillotson, Stillingfleet, Bishop Pearson, Sherlock, South, Sprat, Cudworth, and Burnet. Other features of the last part of the 17th century were the immense advance in physical science under Boyle, Isaac Newton, Harvey, and others, and the rise of the newspaper press.

Dryden's death in 1700 marks the commencement of the so-called Augustan age in English literature. During it, however, no greater poet appeared than Pope (1688-1744), in whom sagacity, wit, and fancy take the place of the highest poetic faculty, but who was a supreme artist within the formal limits of his conception of metrical art. Against these formal limits signs of reaction are apparent in the verse of Thomson (1700-48), Gray (1716-71), Collins (1720-59), Goldsmith (1728-74), and in the productions of Macpherson and Chatterton. The poets Prior (1664-1721), Gay (1688-1732), and Ambrose Phillips (1671-1749) inherit from the later 17th century, Gay being memorable in connection with English opera; and there are a large number of small but respectable poets—Garth, John Philips, Blackmore, Parnell, Dyer, Somerville, Green, Shenstone, Blair, Aken-side, Falconer, Anstey, Beattie, Allan Ram-

say, and Robert Fergusson. It is in prose that the chief development of the 18th century is to be found. Defoe (1661-1731) and Swift (1667-1745) led the way in fiction and prose satire; Steele (1672-1729) and Addison (1672-1719), working on a suggestion of Defoe, established the periodical essay; Richardson (1689-1761), Fielding (1707-54), Smollett (1721-71), and Sterne raised the novel to sudden perfection. Goldsmith also falls into the fictional group as well as into those of the poets and the essayists. Johnson (1709-84) exercised during the latter part of his life the power of a literary dictator, with Boswell (1740-95) as literary dependent. The other chief prose writers were Bishop Berkeley (1685-1753), Arbuthnot (1675-1735), Shaftesbury (1671-1713), Bolingbroke (1678-1751), Burke, the historians David Hume (1711-76), William Robertson (1721-93), Edmund Gibbon (1737-94); the political writers Wilkes and Junius, the economist and moral philosopher Adam Smith (1723-90); the philosophical writers Hume, Bentham (1749-1832), and Dugald Stewart (1753-1828); the scholars Bentley (1662-1742), Sir William Jones (1746-94), and Richard Porson (1759-1808); the theologians Atterbury, Butler (1692-1752), Warburton, and Paley; and some inferior playwrights, of whom Rowe, John Home, Colley Cibber, Colman the elder, Foote, and Sheridan were the most important.

With the French Revolution, or a few years earlier, the modern movement in literature may be said to have commenced. The departure from the old traditions, traceable in Gray and Collins, was more clearly exhibited in the last years of the century in Cowper (1731-1800) and Burns (1759-96), and was developed and perfected in the hands of Blake (1757-1828), Bowles (1762-1850), and the 'Lake poets' Wordsworth (1770-1850), Coleridge (1772-1834), and Southey (1774-1843); but there were at first many survivals from the poetic manner of the 17th century, such as Erasmus Darwin (1731-1802), Dr. John Wolcot (1738-1819), Robert Bloomfield (1766-1823), and Samuel Rogers (1763-1855). Amongst the earlier poets of the century, also, were George Crabbe (1754-1832), Sir Walter Scott (1771-1832), Hogg (1772-1835), Campbell (1777-1844), James Montgomery, Mrs. Hemans, Bryan Waller Procter ('Barry Cornwall'), Milman, L. E. Landon, Joanna Baillie, Robert Montgomery. A

more important group was that of Byron (1788–1824), Shelley (1792–1822), and Keats (1796–1821), with which may be associated the names of Leigh Hunt (1784–1859), Thomas Moore (1779–1852), and Landor (1775–1864). Among the earlier writers of fiction there were several women of note, such as Maria Edgeworth (1767–1849) and Jane Austen (1775–1817). The greatest name in fiction is unquestionably that of Scott. Other prose writers were Mackintosh, Malthus, Hallam, James Mill, Southey, Robert Hall, John Foster, Thomas Chalmers, Hannah More, Cobbett, William Hazlitt, Sydney Smith, Francis Jeffrey, Lord Brougham. In the literature since 1830 poetry has included as its chief names those of Praed, Hood, Aytoun, Lord Houghton, Sidney Dobell, Alexander Smith, Gerald Massey, Charles Mackay, Philip James Bailey, William Allingham, Elizabeth Barrett Browning, Coventry Patmore, Lord Lytton (Owen Meredith), Arthur Hugh Clough, Matthew Arnold, Dante G. Rossetti, Robert Buchanan, Wm. Morris, Lewis Morris, Jean Ingelow, Swinburne, and last and greatest, Tennyson and Browning. A brilliant list of novelists for the same period includes Marryat, Michael Scott, Lord Lytton, Ainsworth, Benjamin Disraeli (Earl of Beaconsfield), Dickens, Thackeray, Charles Kingsley, Charlotte Brontë, Lover, Lever, Wilkie Collins, Mayne Reid, George Macdonald, Charles Reade, George Eliot, Anthony Trollope, William Black, Thomas Hardy, R. D. Blackmore, George Meredith, Miss Braddon, Mrs. Craik (Miss Muloch), Mrs. Oliphant, Miss Yonge, Miss Thackeray, and others. To the historical and biographical list belong Alison, Macaulay, Buckle, Carlyle, Cornwall Lewis, Thirwall, Grote, Milman, Froude, Lecky, S. R. Gardiner, Kinglake, John Richard Green, E. A. Freeman, Hill Burton, Stubbs, Dean Stanley, David Masson, John Morley, Leslie Stephen. Prominent amongst the theological writers have been Dr. Newman, Whately, Augustus and Julius Hare, Trench, Stanley, Maurice, Hamilton, Alford, F. W. Robertson, Stopford Brooke, Liddon, Isaac Taylor, Jowett, James Martineau, Tulloch, and Caird. In science and philosophy among the chief writers have been Whewell, Sir W. Hamilton, Mansel, John Stuart Mill, Alexander Bain, Hugh Miller, Charles Darwin, Huxley, Tyndall, Max Müller, Herbert Spencer, T. H. Green. Of the other prose writers of importance the chief

are De Quincey, Harriet Martineau, Sir Arthur Helps, Ruskin, Matthew Arnold, W. E. Gladstone. A large and increasing number of writers of American and colonial birth have to be added to the native contributors to English literature in its widest sense. See *United States*.

England, New. See *New England*.

English Bazar, a town of Bengal, on the Mahánandá. Pop. 12,430.

English Channel, the arm of sea which separates England from France, extending, on the English side, from Dover to the Land's End; and on the French, from Calais to the Island of Ushant. On the east it communicates with the German Ocean by the Strait of Dover, 21 miles wide; and on the west it opens into the Atlantic by an entrance about 100 miles wide. At its greatest breadth it is about 150 miles. The pilchard and mackerel fisheries are very important.

The advantages of a railway tunnel across the Channel at its narrowest part have been frequently urged; and an English company formed for the purpose of constructing a tunnel half-way across from Dover, to meet a similar tunnel starting from near Calais, has pushed an excavation under the sea for over 2000 yards, but has been interdicted by the British government for military reasons. This tunnel would have a total length of 23 miles.

English Church, Language, Literature, &c. See *England*.

Engraving, the art of representing objects and depicting characters on metal, wood, precious stones, &c., by means of incisions made with instruments variously adapted to the substances operated upon and the description of work intended. Impressions from metal plates are named engravings, prints, or plates; those printed from wood being called indifferently wood engravings and wood-cuts. While, however, these impressions are not altogether dissimilar in appearance, the processes are distinct. In plates the lines intended to print are incised, and in order to take an impression the plate is daubed over with a thick ink which fills all the lines. The surface is then wiped perfectly clean, leaving only the incised lines filled with ink. A piece of damp paper is now laid on the face of the plate, and both are passed through the press, which causes the ink to pass from the plate to the paper. This operation needs to be repeated for every impression. In the

wood block, on the contrary, the spaces between the lines of the drawing are cut out, leaving the lines standing up like type, the printing being from the inked surface of the raised lines, and effected much more rapidly than plate printing.

Engraving on wood, intended for printing or impressing from, long preceded engraving on metals. The art is of eastern origin, and at least as early as the 10th century engraving and printing from wood blocks was common in China. We first hear of wood engraving being cultivated in Europe by the Italians and Germans in the 13th century. For a hundred and fifty years, however, there is small indication of the practice of the art, which was at first confined to the production of block-books, playing cards, and religious prints. In the 15th century the art of printing from engraved plates was discovered in Florence by Maso Finiguerra. Engraving had long been used as a means of decorating armour, metal vessels, &c., the engravers generally securing duplicates of their works before laying in the niello (a species of metallic enamel) by filling the lines with dark colour, and taking casts of them in sulphur. The discovery of the practicability of taking impressions upon paper led to engraving upon copper plates for the purpose of printing from. The date of the earliest known niello proof upon paper is 1452. The work of the Florentine engravers, however, was almost at once surpassed in Venice and elsewhere in North Italy by Andrea Mantegna (1431-1505), Girolamo Mocetto, Giovanni Batista del Porto, and others. In Marc Antonio Raimondi (1475-1534), who wrought under the guidance of Raphael, and reproduced many of his works, the art reached its highest point of the earlier period, and Rome became the centre of a new school, which included Marco da Ravenna (d. 1527), Giulio Bonasone (1531-72), and Agostino de Musis (fl. 1536). In the meantime, in Germany the progress of the art had been not less rapid. Of the oldest school the most important engraver is Martin Schongauer (1420-88). He was, however, surpassed a generation later by Albert Durer (1471-1528), who excelled both in copper and wood engraving, especially in the latter. Among his most famous contemporaries and successors were Burgkmair and Lucas Cranach. The Dutch and Flemish schools, of which Durer's contemporary Lucas van Leyden was the head, did

much to enlarge the scope of the art, either by paying increased attention to the rendering of light and shade, and the expression of local colour, as in the case of Cornelius Cort and Bloemart; or by developing freedom and expression of line, as in the case of Goltzius and his pupils. Rubens (1577-1640) influenced engraving through the two Bolswerts, Vorstermann, Pontius, and P. de Jode, who engraved many of his works on a large size. Towards the end of the 17th century etching, which had before been rarely used, became more common, and was practised with great success by Rembrandt (1607-69) and other painters of that period. In France Noel Garnier founded a school of engraving about the middle of the 16th century; but it produced no work of any high distinction until the reign of Louis XIV., when Nanteuil's pupil Gerard Edelinck and Gerard Audran flourished. The former was skilled in using his graver to produce colour effects, the latter is famed for his engravings from Nicolas Poussin and Le Brun. But these were all surpassed about the middle of the 18th century by Wille (1717-1807), a German resident in Paris. Before the middle of the 17th century England produced little noteworthy work, availing herself principally of the work of foreign engravers, of whom many took up temporary and even permanent residence. The first English engraver of marked importance was William Hogarth (1697-1764), whose works are distinguished for character and expression. Vivares (1712-82), a Frenchman by birth, laid the foundation of the English school of landscape-engraving, which was still further developed by William Woollet (1735-85), who was also an excellent engraver of the human figure. In historical engraving a not less remarkable advance was made by Sir Robert Strange (1721-92), and Richard Earlom (1743-1822) produced some admirable works in mezzotint. In succession to these came William Sharp (1746-1824), James Bazire (1730-1802), Bartolozzi (1727-1815), James Heath, Bromley, Raimbach, and others. The substitution of steel for copper plates (1820-30) gave the power of producing a much larger number of fine impressions, and opened new possibilities for highly-finished work. During the closing years of the 18th century line engraving attained a depth of colour and fulness of tone in which earlier works generally are deficient, and during the present century it has reached a

perfectness of finish which it had not previously attained. A picture, whether figure or landscape, may be translated by line engraving with all its depth of colour, delicacy of tone, and effect of light and shade; the various textures, whether of naked flesh, silk, satin, woollen, or velvet, all successfully rendered by ingenious modes of laying the lines and combinations of lines of varying strength, width, and depth. Among engravers who have produced historical works of large size and in the line manner the names of Raphael Morghen (1758-1833), Longhi (1766-1831), Anderloni (1784-1849), Garavaglia (1790-1835), and Toschi, in Italy; of Forster (1790-1872), Henriquel-Dupont (b. 1797), Bridoux (b. 1812), and Blanchard (b. 1819), in France; of John Burnet (1784-1868), J. H. Robinson (1796-1871), Geo. T. Doo (1800-86), J. H. Watt (1799-1867), and Lumb Stocks (b. 1812), in England, stand pre-eminent. Among historical and portrait engravers in the stipple or dotted manner the names of H. T. Ryall, Henry Robinson, William Holl (1807-71), and Francis Holl, may well be mentioned. In the period 1820-60 landscape engraving attained a perfection in Great Britain which it had not attained in any other country, or at any other time. Among landscape engravers the names of Geo. Cooke (1781-1834), William Miller (1796-1882), E. Goodall (1795-1870), J. Cousen (1804-80), R. Brandard (1805-62), and Wm. Forrest (b. 1805) hold the foremost places. In mezzotinto engraving Samuel Cousins (1801-87) is unrivalled. In the period 1830-45 various publications called *Annuals*, composed of light literature in prose and verse, and illustrated by highly-finished engravings in steel, were very popular. The engravings were necessarily of small size, and are generally of great excellence. A number of them both figure and landscape are executed with such finish and completeness as to be esteemed perfect works. The unrivalled illustrations of Rogers' *Poems* and Rogers' *Italy* after Turner and Stothard belong to this period. Many of the originals of the engravings in the *Annuals* were finished pictures of large size. A great part of the difficulty in engraving on a small scale from a large picture, consists in determining what details can be left out, and still preserve the full effect and character of the original. The most noted engravers for work of small size are Charles Heath, Charles Rolls, W. Finden, E. Finden, E. Portbury,

J. Goodyear, F. Engleheart, Henry Le Keux, E. Goodall, and W. Miller. Since 1870 many plates have been produced by a combination of etching and dry point, a comparatively cheap and rapid process. Such works have been fashionable and very popular with collectors. But while some of them have been excellent of their kind, the process is of limited resource, and the best works in this manner will not stand comparison with the masterpieces of line engraving. Through lack of encouragement, change of fashion, and the adoption of other methods of reproduction, line engraving is rapidly becoming a lost art in Great Britain. The men who made line engraving famous are either dead or too old to work, and there has been no sufficient inducement for younger men to pursue that art. In France and in Germany some able line engravers are still in practice.

Line Engraving, as implied by the term, is executed entirely in lines. The tools are few and simple. They consist of the graver or *burin*, the point, the scraper, and the burnisher; an oil-stone or hone, dividers, a parallel square, a magnifying lens; a bridge on which to rest the hand; a blind or shade of tissue paper, to make the light fall equally on the plate, callipers for levelling important erasures, a small steel anvil, a small pointed hammer, and punches. In etching, the following articles are required:—a resinous mixture called etching-ground, capable, when spread very thinly over the plate, of resisting the action of the acids used; a dauber for laying the ground equally; a hand-vice; some hair-pencils of different sizes, and bordering wax, made of burgundy-pitch, bees'-wax, and a little oil.

In engraving, the plate, which is highly polished and must be free from all scratches, is first prepared by spreading over it a thin layer of *ground*. The surface is then smoothed, and the outline of the picture transferred to it by pressure from the paper on which it has been drawn in fine outlines by a black-lead pencil. The picture is then drawn on the ground with the etching-needle, which removes the ground in every form produced by it, and leaves the bright metal exposed. A bank of wax is then put round the plate and diluted acid poured on it, which eats out the metal from the lines from which the ground has been removed, but leaves the rest of the plate untouched. The plate is then gone over with the graver, the etched lines clearly defined,

broken lines connected, new lines added, &c. Sometimes the plate is *rebitten* more than once, those parts which are sufficiently bitten in the first treatment being *stopped* with varnish, and only the selected parts exposed to after-biting. Finally the burnisher is brought into play alternately with the graver and point to give perfectness and finish. Such is the process for landscape engraving. In historical and portrait engraving of the highest class, the lines are first drawn on the metal with a fine point and then cut in by the graver, first making a fine line and afterwards entering and re-entering till the desired width and depth of lines is attained. Much of the excellence of such engravings depends on the mode in which the lines are laid, their relative thickness, and the manner in which they cross each other. In historical engraving etching is but little used, and then only for accessories and the less important parts.

Soft-ground Etching.—The ground, made by mixing lard with common etching-ground, is laid on the plate and smoked as before, but its extreme softness renders it very liable to injury. The outline of the subject is drawn on a piece of rough paper larger than the plate. The paper is then damped, and laid gently over the ground face upwards, and the margins folded over and pasted down on the back of the plate. When the paper is dry and tightly stretched the bridge is laid across, and with a hardish pencil and firm pressure the drawing is completed in the usual manner. The pressure makes the ground adhere to the back of the paper at all parts touched by the pencil, and on the paper being lifted carefully off, these parts of the ground are lifted with it, and the corresponding parts of the plate thus left bare are exposed to the subsequent action of the acid. The granulated surface of the paper, causing similar granulations in the touches on the ground, gives the character of a chalk-drawing. The biting-in is effected in the same manner as already described, and the subject is finished by re-biting and dotting with the graver.

Stipple, or Chalk Engraving, in its pure state, is exclusively composed of dots, varying in size and form as the nature of the subject demands, but few stipple plates are now produced without a large admixture of line in all parts, flesh excepted. A great advance, however, has been made in stipple engraving by the introduction of large and varied forms of dotting in the draperies, the

results almost rivalling line engraving in richness and power.

The processes of *Aquatint* and *Mezzotint* will be found under their respective heads, the latter differing from all other styles of engraving in that the lights and gradations are scraped or burnished out of a dark ground that has first been wrought upon the plate, instead of the forms being corroded or cut into a plain surface.

The Mixed Style is based on mezzotinto, which, still forming the great mass of shading, is in this method combined with etching in the darker, and stipple in the more delicate parts. By this combination a plate will produce a larger number of good impressions than were it done entirely in mezzotinto.

Engraving on Wood.—The wood best adapted for engraving is box. It is cut across the grain in thicknesses equal to the height of type, these slices being subjected to a lengthened process of seasoning, and then smoothed for use. Every wood engraving is the representative of a finished drawing previously made on the block; the unshaded parts being cut away, and the lines giving form, shading, texture, &c., left standing in relief by excavations of varied size and character, made between them by gravers of different forms. Drawings on wood are made either with black-lead pencil alone or with pencil and indian ink, the latter being employed for the broader and darker masses. It is now much the practice to photograph drawings made in black and white upon the wood instead of making the drawing on the wood block. When the drawing is put on the wood by washes or by photography instead of being entirely done by pencil lines, the engraver has to devise the width and style of lines to be employed instead of cutting in fac-simile, as is the case when the drawing is made entirely in lines. The tools required for wood engraving are similar but more numerous than those of the engraver on copper or steel. See also *Die-sinking, Gems.*

Engrossing, in law, denotes *extending* a deed, that is, rewriting it out fully in fair and legible characters.

Engrossing, **FORESTALLING**, and **REGRATING**, terms formerly in use for the purchase of corn or other commodities in order to sell again at a higher price, or in order to raise the market price of the same. These practices were once regarded as criminal, and positive statutes against them were passed

in England in 1266-67, in 1350-52, in 1552, in 1562, and in 1570. The offence of *engrossing* was described by the statute of Edward III. as the 'getting into one's possession, or buying up, large quantities of corn, or other dead victuals, with intent to sell them again;' *forestalling*, as the 'buying or contracting for any cattle, merchandise, or victual, coming in the way to the market, or dissuading persons from bringing their goods or provisions there, or persuading them to enhance the price when there;' and *regrating*, 'the buying of corn or other dead victual in any market and selling it again in the same market, or within 4 miles of the place.' By the statute of Edward VI. the engrossing of corn, which included the buying of it in one market to sell it in another, was made punishable by imprisonment and pillory; and no one could carry corn from one part of the kingdom to another without a license. All the positive statutes against these offences were repealed in 1772, but they were still found to be punishable by common law, and it was not till 1844 that they entirely ceased to rank among offences.

Enharmonic, in music, is an epithet applied to intervals smaller than the regular divisions of the scale, *i.e.* less than semitones. Enharmonic intervals can be produced on stringed instruments, or on specially constructed fixed-tone instruments having more than twelve divisions in the octave.

Enkhuizen (eng'k'hoi-zn), a seaport of Holland, on a projection in the Zuider Zee, 29 miles north-east of Amsterdam. It had formerly a pop. of 40,000, but the silting up of the harbour has caused its decay, and its inhabitants number now about 5000.

Enlistment, the method by which the regular army is supplied with troops, as distinguished from *conscription*. Up to 1802 the enlistment of men for the British army was left in the hands of private undertakers, or middlemen, who received a commission on the recruits they procured; but the abuses of this system induced the government to take the matter into their own management. At an early period enlistment was for short periods, but this was soon changed to enlistment for life. The act of 1847 limited the term of enlistment to ten years for the infantry and twelve for the cavalry, artillery, and ordnance; re-enlistments for periods of eleven and twelve years might be made, after serving which retiring

pensions were granted. By the acts of 1870 and 1881 the system of long and short service was introduced. By both acts the term of long service was fixed for twelve years, at the expiry of which period the soldier may re-enlist for other nine years, service for the two terms, or twenty-one years, entitling him to a pension. The short service of the first act extended over six years with the regular army and six years in the first-class reserve; the short service of the act of 1881 is seven years in the regular army and five in the reserve. The Foreign Enlistment Act of 1819 forbids British subjects serving with a foreign state without royal license, and also the equipment of ships to serve against a power with which Britain is at peace. It was amended by a new act passed in 1870. In the navy a seaman may engage for five or ten years, for the period his ship is in commission, or for a longer period. He receives higher pay for longer service. (See *Naval Reserve*.) In the United States men are enlisted for five years' duty in every branch, and recruits are assigned to regiments by order of the war department.

Enlistments during the Civil War IN THE U. STATES. The 'calls' for troops by the government during the civil war were as follows: April 15, 1862, 75,000 for three months; number enlisting, 93,326. May-June 25, 1862, 530,000 for three years; enlistments, 714,213. July 2, 1862, 300,000 for three years; enlistments, 431,958. Aug. 4, 1862, 300,000 for nine months; enlistments, 87,000. The 'calls' from Oct. 17, 1863, were orders for drafts; on that day was issued a 'call' for 300,000 for three years, and Feb. 1, 1864, a 'call' for 200,000 for the same term—these two 'calls' bringing 374,807 into service. Mar. 14, 1864, 200,000 men were called for, for three years, resulting in 284,021 entering the service. July 18, 1864, 500,000 men for 1, 2, and 3 years; number obtained, 384,882. The last 'call,' Dec. 19, 1864, for 300,000, for 1, 2, and 3 years, brought 204,568, into service. The whole number called for was 2,759,049; number obtained, 2,656,553. Probably not more than 50,000 drafted men performed personal service, substitutes being obtained. The 'substitute fund,' consisting of money paid as a release from service, which was used as a 'bounty fund' for volunteers, amounted to \$25,902,000.

Ennius, **QUINTUS**, an early Latin poet, considered by the Romans as the father of their literature, was born at Rudia, near

Brundisium, 239 B.C., died 169 B.C. He wrote an epic, Scipio, in hexameters; Roman annals; tragedies and comedies; satires, epigrams, precepts, &c. His whole works are supposed to have been extant up to the 13th century, but nothing now remains but fragments quoted from other ancient authors.

Enns, a river in Austria, which rises in the Alps of Salzburg, flows N., then E.N.E., then N.N.W. entering Upper Austria (Ober der Enns), which for 15 miles it separates from Lower Austria (Unter der Enns), and finally enters the Danube a little below the town of Enns (4438 inhabitants). Total course about 160 miles.

Enoch (ē'nok), (1) The eldest son of Cain, who called the city which he built after his name (Gen. iv. 17). (2) One of the patriarchs, the father of Methuselah. He 'walked with God; and he was not; for God took him' (Gen. v. 24) at the age of 365 years. The words quoted are generally understood to mean that Enoch did not die a natural death, but was removed as Elijah was.

Enoch, BOOK OF, an apocryphal book of an assumedly prophetic character, to which considerable importance has been attached on account of its supposed quotation by St. Jude in the 14th and 15th verses of his epistle. It is referred to by many of the early fathers; is of unknown authorship, but was probably written by a Palestinian Hebrew. Its date is also uncertain, critical conjecture ranging from 144 B.C. to 132 A.D. Until the close of last century it was known in Europe only by the references of early writers, and by the passage of St. Jude supposed to be founded on it. On his return from Egypt Bruce brought with him from Abyssinia three manuscripts containing a complete Ethiopic translation of it. It has since been repeatedly published, translated, and criticised in Europe.

E'nos, a seaport of European Turkey, in Roumelia, 38 miles N.W. of Gallipoli, on the Ægean Sea, in the Gulf of Enos. Pop. 7000.—The Gulf of Enos is 14 miles in length by about 5 in breadth.

En'sign, formerly, in the British army, the officer who carried the flag or colours of an infantry regiment; for this title, second lieutenant has been substituted. In naval language the ensign is the flag over the poop or stern which distinguishes the ships of different nations. In the royal navy of Britain it is a flag with a white field divided into quarters by the red cross of St. George, and having the union (or Union Jack as it

is commonly called) in the upper corner next the staff. In the United States navy an ensign ranks next below lieutenant.

En'silage, in agric., a mode of storing green fodder, vegetables, &c., in receptacles called 'silos.' These are usually pits of quadrangular form, lined with wood, brick, concrete, or stone. The fodder, &c., is cut and mixed, placed in the silo, pressed down, and kept compressed by heavy weights placed on a movable wooden covering. It undergoes a slight fermentation, and attains a slightly acid taste and smell, which is particularly grateful to cattle. The modern system of ensilage dates from about 1875, but the practice was known to the ancient Romans, and the system has been common in Mexico for centuries. Such advantages are claimed for it, as that in a wet season grass can be made into ensilage instead of hay, and that there is little loss of nutritive elements, while it has great feeding powers. Recent experiments seem to show that green fodder may be converted into ensilage without a pit by simply piling up and consolidating by pressure.

Entab'lature, in architecture, the horizontal, continuous work which rests upon a row of columns, and belongs especially to classical architecture. It consists of three principal divisions — the

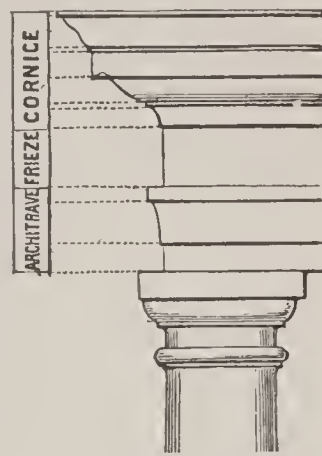

Entablature of Tuscan Column.

architrave immediately above the abacus of the column, next the *frieze*, and then the *cornice*. In large buildings projections similar to and known also as entablatures are often carried round the whole edifice, or along one front of it.

Enta'da, a genus of leguminous plants, sub-order Mimoseæ, containing about a dozen species of climbing tropical shrubs, remarkable for the great size of their pods. *E. scandens* has pods which measure from 6 to 8 feet in length. The seeds have a hard, woody, and beautifully polished shell, and are often made into snuff-boxes, scent-bottles, &c.

Entail', in law, the settlement of an estate by which a freehold is limited to a person and the heirs of his body, with such particular restrictions as the donor may

specify. Entailed estates are divided into *general* and *special*, the former when the estate is given to the donee and his heirs without exception, the latter when the estate is limited to certain heirs to the exclusion of others.

Entasis, in arch., the delicate and almost imperceptible swelling of the lower part of the shaft of a column, to be found in almost all the Grecian examples, adopted to give a more pleasing effect to the eye.

Entel'echy, in the peripatetic philos., an object in its complete actualization, as opposed to merely potential existence.

Entellus, an East Indian species of monkey, of the genus *Semnopithēcus* (*S. entellus*). It has yellowish fur, with a face of a violet tinge, and a long and powerful tail, which, however, is not prehensile. It receives divine honours from the natives of India, by whom it is termed *Hoonuman*. Costly temples are dedicated to these animals; hospitals are built for their reception, and large fortunes are bequeathed for their support. The entellus abounds in India; enters the houses and gardens of the natives, plunders them of fruit and eatables, and the visit is even considered an honour.

Enter'ic Fever. See *Typhoid Fever*.

Enterit'is (Greek, *enteron*, intestine), inflammation of the intestines. There are several forms of the disease of great severity and very fatal. A common form, which is of the nature of an intestinal catarrh, generally yields to simple treatment; but other forms are of great danger, and demand skilled and attentive treatment.

Entomol'ogy, the branch of zoology which treats of the insects, the name being from Greek *entōma*, animals 'cut in,' the transverse division or segmentation of the body being their most conspicuous feature. The true insects are those animals of the division Arthropoda or Articulata distinguished from the other classes of the division by the fact that the three divisions of the body—the head, thorax, and abdomen—are always distinct from one another. There are never more than three pairs of legs in the perfect insect, and these are all

borne upon the thorax. Each leg consists of from six to nine joints. The first of these is called the 'coxa,' and is succeeded by a short joint called the 'trochanter.' This

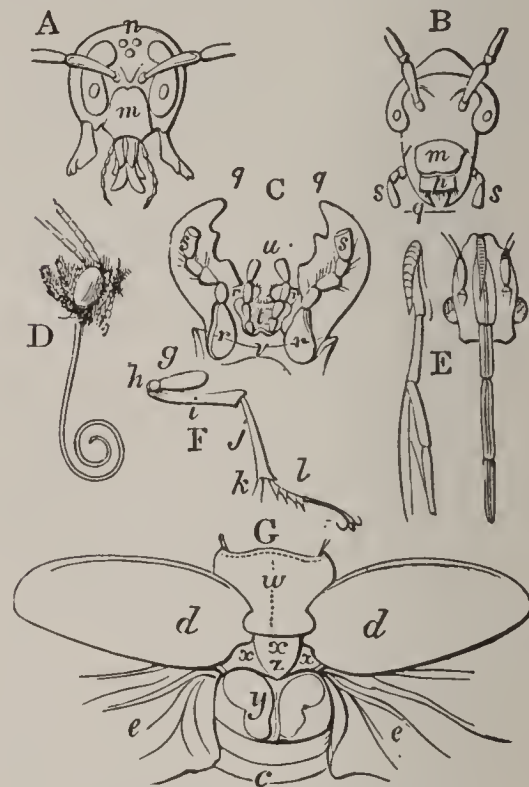

Figure showing Parts of Insects.

A, B, C, Mandibulate Mouth. A, Head of Hornet, and upper side of mouth. m, Clypeus. n, Ocelli, stemmata, or simple eyes. o, Compound eyes. B, Head of Beetle, and C, under side of mouth of Beetle. m, Clypeus. o, Eyes. p, Labrum or upper lip. q, Mandibles or upper jaws. r, Maxillæ or lower jaws. s, Maxillary palpi. t, Labium or under lip. u, Labial palpi. v, Mentum or chin.—D and E, Haustellate Mouths. D, Spiral sucker of a Butterfly, called also Antlia. E, Straight sucker of a Plant-bug (*Pentatoma*) called Haustellum.—F, Leg of Stag-beetle. g, Coxa. h, Trochanter. i, Femur. j, Tibia. k, Calcaria or spurs. l, Tarsus, which in this instance is pentamerous, or consisting of five pieces.—G, Thorax of Stag-beetle. c, Abdomen. dd, Elytra. ee, Wings. w, Prothorax. x, Mesothorax. y, Metathorax. z, Scutellum.

is followed by a joint, often of large size, called the 'femur,' succeeded by the 'tibia,' and this has articulated to it the 'tarsus,' which may be composed of from one to five joints. Normally two pairs of wings are present, but one or other may be wanting. The wings are expansions of the sides of the second and third sections of the thorax, and are attached by slender tubes called 'nervures.' In the beetles the anterior pair of wings becomes hardened so as to form protective cases for the posterior membranous wings, and are called in this condition 'elytra' or 'wing-cases.' Respiration is effected by means of air-tubes or tracheæ, which commence at the surface of the body by lateral apertures called 'stigmata' or 'spiracles,' and ramify through every part of the body. The head is com-



Figure showing Parts of Insects. Coleopter (*Cicindela campestris*). a, Head. b, Thorax. c, Abdomen. dd, Elytra. ee, Wings. ff, Antennæ.

posed of several segments amalgamated together, and carries a pair of feelers or 'antennæ,' a pair of eyes, usually compound, and the appendages of the mouth. The thorax is composed of three segments, also amalgamated, but generally pretty easily recognized. The abdominal segments are usually more or less freely movable upon one another, and never carry locomotive limbs; but the extremity is frequently furnished with appendages connected with generation, and which in some cases serve as offensive and defensive weapons (stings). The organs of the mouth take collectively two typical forms, the masticatory and the suctorial, the former exemplified by the beetles, the latter by the butterflies, in which the mouth is purely for suction. The alimentary canal consists of the œsophagus or gullet, a crop, a gizzard, a stomach, and an intestine, terminating in a cloaca. There is no regular system of blood-vessels; the most important organ of the circulation is a contractile vessel situated dorsally and called the 'dorsal vessel.' The nervous system is mainly composed of a series of ganglia placed along the ventral aspect of the body and connected by a set of double nerve-cords. The sexes are in different individuals, and most insects are oviparous. Reproduction is generally sexual, but non-sexual reproduction also occurs. (See *Parthenogenesis*.) Generally the young are very different from the full-grown insect, and pass through a 'metamorphosis' before attaining the mature stage. When this metamorphosis is complete it exhibits three stages—that of the larva, caterpillar, or grub, that of the pupa or chrysalis, and that of the imago or perfect winged insect. Insects have been divided into three sections—*Ametabola*, *Hemimetabola*, and *Holometabola*, according as they undergo no metamorphosis, an incomplete one, or a complete one. The young of the *Ametabola* differ from the adult only in size. They are all destitute of wings; the eyes are simple and sometimes wanting. The *Hemimetabola* undergo an incomplete metamorphosis, the larva differing from the imago chiefly in the absence of wings and in size. The pupa is usually active, or if quiescent capable of movement. In the *Holometabola* the metamorphosis is complete, the larva, pupa, and imago differing greatly from one another in external appearance and habits. The larva is wormlike and the pupa quiescent. The section *Ametabola* (which in the opinion of many

naturalists are scarcely within the pale of the true *Insecta*) is divided into three orders—*Anoplūra* (lice), *Mallophaga* (bird-lice), and *Thysanūra* (springtails). The section *Hemimetabola* comprises the orders *Hemiptera* (cicadas, bugs, plant-lice, &c.), *Orthoptera* (cockroaches, crickets, grasshoppers, locusts, earwigs, &c.), and *Neuroptera* (dragon-flies, may-flies, white-ants, &c.). The *Holometabola* comprises the orders *Aphaniptera* (fleas), *Diptera* (gnats, bot-flies, gad-flies, mosquitos, house-flies, &c.), *Lepidoptera* (butterflies and moths), *Hymenoptera* (bees, wasps, and ants), *Strepsiptera* (stylops, minute and parasites), and *Coleoptera* (lady-birds, glow-worms, cockchafers, weevils, and all of the beetle tribe). A division is sometimes made into *Mandibulate* and *Haustellate* groups, the oral apparatus of the former being adapted for mastication, the latter for imbibition of liquid food. Both types are, however, sometimes modified, and occasionally combined.

Entomoph'aga ('insect eaters'), a term applied to (1) a group of hymenopterous insects whose larvæ feed upon living insects. (2) A tribe of marsupials, as the opossums, bandicoots, &c., which are insectivorous, though not exclusively so. (3) A section of the edentates, as the ant-eater and pangolin.

Entomos'traca, a subclass of the crustaceous animals, composing all except the stalk-eyed and sessile-eyed groups. The groups usually noted by it are the *Ostracōda*, as *Cypris*; *Copepōda*, as *Cyclops*; *Cladocēra*, as *Daphnia* (water-flea); *Branchiopōda*, as the brine-shrimp and the glacier-flea; *Trilobites*, all of which are extinct; *Merostomūta*, of which the king-crab is the only living genus. No definition can be framed to

include all these groups, each of which is now usually regarded as a distinct order.

En'tophyte, a term applied to minute plants growing on or in living animals, or in the tissues of other plants. They all belong to the orders *Algæ* or *Fungi*. In many cases the growth of the plant appears to be a consequence of the diseased state of the structure, which, in this condition, presents the circumstances favourable for the develop-

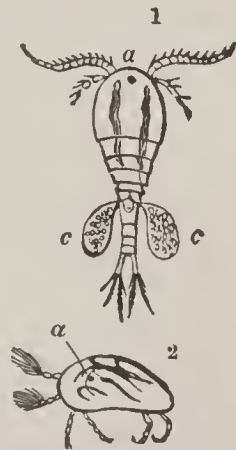

Entomostraca.

1, *Cyclops quadricornis*: a, Eye; cc, Eggs.
2, *Cypris*: a, Eye.

ment of the germ or spore into the plant. Epidemic diseases, as cholera, have been ascribed to these spores or germs being conveyed through the air. See *Germ Theory*.

Entozo'a, a general name for those annulose parasitical animals, which infest the bodies of other animals. Some are found in the intestines, others in the liver, brain, muscles, and other tissues. They pass

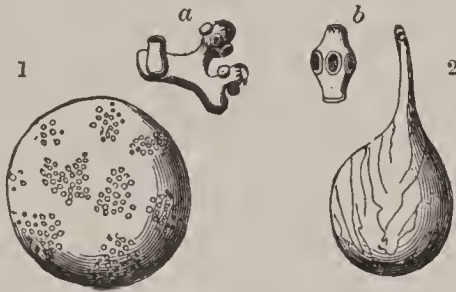

Entozoa magnified.

1, *Cœnurus cerebralis* (producing the staggers in sheep). a, Heads (shown on the surface) separately. 2, *Cysticercus cellulosæ* (causing the measles in pigs). b, Head.

through different stages in their development, and at each stage occupy a different tissue and usually a different animal. Thus the cystic or bladder worm, whose presence in the brain of sheep causes staggers, is the immature form of the tapeworm of the dog, &c. The number of species is being reduced as the relations of the different forms are studied. They all belong to the class *Scolēcida*, and are included in the orders *Trematōda* (flukes), *Teniāda* (tape-worms), *Acanthocephāla* (intestinal worms), *Gordiacēa* (hair-worms), and a section of the *Nematōda* (*Trichīna*, &c.).

Entr'acte (ân-trâkt; Fr.), the interval between the acts of a drama; or a short musical entertainment performed during such interval.

Entre-douro-e-Minho, a province of Portugal. See *Minho*.

Entrées (ân-trāz), in cookery, made-dishes comprising cutlets, fricassees, sweet-breads, and similar dishes, usually served hot before the joints at dinner. — *Entremets* are similar dishes, but of a more delicate character, served between the main dishes of the second course at dinner.

Entrepôt (ân-tr-pō; Fr.), a port where foreign merchandise which cannot enter the interior of a country is deposited in magazines under the surveillance of the custom-house officers till it is re-exported; also, any place where goods are sent to be distributed wherever customers are found.

Entre Rios (en'tre rē'os; 'between rivers'), a province of the Argentine Republic, lying

between the Uruguay and the Paraná; area estimated at 45,000 sq. miles; pop. 300,000. The province is largely pastoral. Capital Concepcion, with a pop. of 10,000.

Entresol (en'tër-sol; Fr. 'between the floors'), a low story between two of greater height, generally the ground and first stories. Called also the *Mezzanine*.

Entropium, in medicine, an inversion or turning in of the eyelashes, consequent either on loss of substance, or on inflammatory swelling of the lid.

En'try, in law, the act of taking possession of lands or tenements by entering or setting foot on the same.

Entry, BILL OF. See *Bill*.

Envelopes, the paper covers that inclose letters or notes. They became common shortly after the introduction of the penny postage system; were at first made chiefly by hand, but are now not only shaped, but folded, gummed, &c., by machinery.

En'voy, a person deputed by a ruler or government to negotiate a treaty, or transact other business, with a foreign ruler or government. We usually apply the word to a public minister sent on a special occasion or for one particular purpose; hence an *envoy* is distinguished from an *ambassador* or permanent resident at a foreign court, and is of inferior rank.

E'ocene, in geology, a term applied to the lower division of the Tertiary strata, from Gr. *ēōs*, dawn, and *kainos*, recent, because remains of existing organic species first occur here. The Eocene beds are arranged in two groups, termed the Lower and Upper Eocene; the strata formerly called Upper Eocene being now known as Oligocene. They consist of marls, limestones, clays, and sandstones, and are found in the Isle of Wight and in the south-east of England and north-west of France, in Central Europe, Western Asia, Northern Africa, and the Atlantic coast of North America.

Eolian Harp. See *Æolian Harp*.

Eolith'ic Period, in archæology, the early part of the palæolithic period of prehistoric time.

Eon de Beaumont. See *D'Eon de Beaumont*.

E'os, among the ancient Greeks the goddess of the dawn. See *Aurora*.

Eötvös (eut'veush), BARON JOSEPH, a Hungarian statesman and author, born 1813, died 1871. He completed his studies at the University of Pesth in 1831. He had already, before leaving the university, produced three

dramas—The Critics, The Wedding, and Revenge—the last a tragedy, all of which were well received. He became a friend of Kosuth, and distinguished himself as a journalist and orator of the popular party. He was minister of public instruction in 1848, but resigned the same year. In 1867 he was again appointed minister of public instruction, which place he retained till his death. Among his works are the novels: The Carthusian, The Village Notary (translated into English), and Hungary in 1514—giving vivid pictures of Hungarian life in modern and more remote epochs.

Eozo'ic Rocks, the name given to the oldest fossiliferous rocks, such as the Laurentian and Huronian of Canada, from their being supposed to contain the first or earliest traces of life in the stratified systems.

Eozo'on, a supposed gigantic fossil foraminifer found in the limestone of the Laurentian rocks of Canada, whence the name *Eozoön canadense*; and in the Archæan rocks of Germany: so called from Gr. *ēōs*, dawn, and *zōon*, an animal, as being the oldest form of life traceable in the past history of the globe. There is doubt, however, as to their being true fossils, many geologists now regarding them as of mineral origin.

Ep'acris, a genus of monopetalous exogens, the typical genus of the natural order Epacridaceæ, distinguished by having a coloured calyx with many bracts, a tubular corolla with smooth limb, stamens affixed to the corolla, and a five-valved many-seeded capsule. The species are shrubby plants, with axillary, white, red, or purple flowers, generally in leafy spikes. Among those cultivated in Britain we may mention *E. grandiflora*, which has flowers nearly an inch in length, of a brilliant reddish purple at the base and pure white at the apex. The order Epacridaceæ consists of plants allied to the heaths, chiefly natives of Australia. The fruit of some species is eaten under the name of Australian cranberry, and they are cultivated in greenhouses for their flowers.



Epacris grandiflora
(garden variety).

the excess of the solar month above the lunar synodical month, and of the solar year above the lunar year of twelve synodical months. The epacts then are *annual* and *menstrual* or *monthly*. Suppose the new moon to be on the 1st of January: the month of January containing 31 days, and the lunar month only 29 days, 12 hours, 44 minutes, 3 seconds; the difference, 1 day, 11 hours, 15 minutes, 57 seconds, is the *menstrual epact*. The *annual epact* is nearly 11 days; the solar year being 365 days, and the lunar year 354. The epacts were once of some importance in ecclesiastical chronology, being used for finding when Easter would fall.

Epaminondas, an ancient Greek hero, who, for a short time, raised his country, Thebes, to the summit of power and prosperity. He was born about 418 B.C., and killed at the battle of Mantinea, 362 B.C. He took the leading part in the struggle during which Spartan supremacy in Greece was destroyed, and the supremacy of Thebes temporarily secured. Four times he successfully invaded the Peloponnesus at the head of the Thebans, but after his death Thebes soon sank to her former secondary condition. Throughout life he was distinguished for the friendship subsisting between him and Pelopidas, with whom he served in the Spartan campaign 385 B.C. His character is one of the finest recorded in Greek history, and his virtues have been praised by both Xenophon and Plutarch.

Eparch (ep'ärk), in Greece, the governor or prefect of a provincial division called an *eparchy*, a subdivision of a nomarchy or province of the kingdom. In Russia an eparchy is the diocese or arch-diocese of a bishop or archbishop.

Epaulement (e-päl'ment), in fortification, a term for the mass of earth or other material which protects the guns in a battery in front and on either flank.

Ep'aulet, EP'AULETTE (Fr. *épaule*, the shoulder), an ornamental shoulder-piece belonging to a military or other dress. Epaulettes were worn in the British army till 1855, and are still worn in the navy by all officers of and above the rank of lieutenant, and by some civil officers.

Epée (è-pā), CHARLES MICHAEL, ABBE DE L', French philanthropist, born in 1712, died 1789. He had chosen the clerical profession, but had to leave the church on account of Jansenist opinions. The great object of his life was the instruction of the deaf and dumb,

Ep'act (Gr. *epaktos*, added), in chronology,

for whom he spent his whole income, besides what was contributed by benevolent patrons; erecting an institution for them at his own cost. He left several works on his method of instruction. See *Deaf and Dumb*.

Epeira (e-pī'ra), a genus of spiders, comprising the largest and best-known British species. *E. diadēma*, the common garden spider, is a handsomely marked species.

Eperies (e-pār'yāsh), a town of Northern Hungary, on the Tarcza, the seat of a Greek Catholic bishop. Pop. 10,139.

Epernay (ep-er-nā), a town of N.E. France, dep. Marne, on the Marne, the central depôt of the wine trade of Champagne. The vast wine-cellars of the town form a labyrinth of galleries cut in the tufa or calcareous soil of the district. Pop. 17,907.

E'phah, or BATH, a Hebrew measure of capacity, containing, according to one estimate or calculation, 8·6696 gallons; according to another only 4·4286 gallons.

Ephem'era, the typical genus of the insect family Ephemerae, Neuropterous insects, so named from the extreme shortness of their lives in the perfect state. They are known as *may-flies* or *day-flies*, and are characterized by the slenderness of their bodies; the delicacy of their wings, which are erect and unequal, the anterior being much the larger; the rudimentary condition of the mouth; and the termination of the abdomen in three filiform appendages. In the state of larvæ and pupæ they are aquatic and exist for years. When ready for their final change they creep out of the water, generally towards sunset of a fine summer evening, beginning to be seen generally in May. They shed their whole skin shortly after leaving the water, propagate their species, and die, taking no food in the perfect state. The may-fly is well known to anglers, who imitate it for bait.

Ephem'eris, an astronomical almanac, such as the *Nautical Almanac and Astronomical Ephemeris*, published by order of the British Admiralty. See *Almanac*.

Ephe'sians, THE EPISTLE TO THE, a canonical epistle addressed by the apostle Paul to the church which he had founded at Ephesus. It was written during his first captivity at Rome, immediately after he had written the Epistle to the Colossians (A.D. 62); and was sent by the hands of Tychicus, who also bore the message to the church at Colossæ.

Eph'esus, an ancient Greek city of Lydia, in Asia Minor, one of the twelve Ionian

cities, on the south side of the Caystrus, near its mouth. It was at one time the grand emporium of Western Asia, having a convenient and spacious harbour. The apostle Paul visited Ephesus and established a Christian church there, to which he dedicated one of his epistles. It was famous for its temple of Artemis (Diana), called *Artemision*, the largest and most perfect model of Ionic architecture, and reckoned one of the seven wonders of the world. The first great temple, begun about B.C. 650 and finished after 120 years, was burnt by the notorious Herostratus in order to perpetuate his name B.C. 356 (the night of Alexander the Great's birth). A second and more magnificent was then erected, which was burned by the Goths in A.D. 262. Some interesting remains have recently been discovered by excavation. Several church councils were held here, especially the third ecumenical council of 431, at which Nestorius was condemned. The site of the city is now desolate; near it is a poor village, Aiasoluk.

Eph'od, a species of vestment worn by the Jewish high-priest over the second tunic. It consisted of two main pieces, one covering the back, the other the breast and upper part of the body, fastened together on the shoulders by two onyx stones set in gold, on each of which were engraved the names of six tribes according to their order. A girdle or band, of one piece with the ephod, fastened it to the body. Just above the girdle, in the middle of the ephod, and joined to it by little gold chains, rested the square breastplate with the Urim and Thummim. The ephod was originally intended to be worn by the high-priest exclusively, but a similar vestment of an inferior material seems to have been in common use in later times among the ordinary priests.

Eph'ors, EPH'ORI, magistrates common to many Dorian communities of ancient Greece, of whom the most celebrated were the Ephori of Sparta. They were five in number, were elected annually, and both the judicial authority and the executive power were almost entirely in their hands. Their power became an intolerable burden, especially to the kings, and in 225 B.C. Cleomenes murdered the whole college and abolished the office.

E'phraem Syrus, that is 'Ephraim the Syrian,' writer of the Syrian Church, born at Nisibis about 306 A.D., died at Edessa in 373 or 378. He wrote several commentaries on Scripture, numerous homilies, and other

works (as well as hymns), which have come down to us partly in Syriac, partly in Greek, Latin, and Armenian translations. His works have been published in Syriac, Greek, and Latin.

E'phraim, the younger son of Joseph, and the founder of one of the twelve tribes of Israel. When the Israelites left Egypt the Ephraimites numbered 40,500, and their possessions in the very centre of Palestine included most of what was afterwards called Samaria.

Ep'ic, a poem of the narrative kind. Some authorities restrict the term to narrative poems written in a lofty style and describing the exploits of heroes. Others widen the definition so as to include not only long narrative poems of romantic or supernatural adventure, but also those of a historical, legendary, mock-heroic, or humorous character. Epic is distinguished from drama in so far as the author frequently speaks in his own person as narrator; and from lyrical poetry by making the predominant feature the narration of action rather than the expression of emotion. Among the more famous epics of the world's literature may be noted: Homer's *Iliad* and *Odyssey*; Virgil's *Æneid*; the German *Nibelungenlied*; the Anglo-Saxon poem of *Beowulf*; the French *Song of Roland*; Dante's *Divina Commedia*; Tasso's *Gierusalemme Liberata*; Ariosto's *Orlando Furioso*; Milton's *Paradise Lost*; Spenser's *Fairy Queen*; Camoens' *Lusiads* (Portuguese); and Firdusi's *Shah Nameh* (Persian). Hesiod's *Theogony*; the poetic *Edda*; the Finnish *Kalewala*; the Indian *Mahâbhârata* may be described as collections of epic legends. The historical epic has an excellent representative in Barbour's *Bruce*; and specimens of the mock-heroic and humorous epic are found in *The Battle of the Frogs and Mice*; *Reynard the Fox*; Butler's *Hudibras*; and Pope's *Rape of the Lock*.

Epicharmus (ep-i-kâr'mus), a Greek writer and philosopher of the Pythagorean school, born in the island of Cos about 540 B.C., died B.C. 450. He removed to Syracuse, where at the court of Hieron he spent the remainder of his life. He is credited with the invention of written comedy.

Epicte'tus, a Greek Stoic philosopher, born in Phrygia about A.D. 60. He lived long at Rome, where, in his youth, he was a slave. Though nominally a Stoic, he was not interested in Stoicism as an intellectual system; he adopted its terminology and its moral

doctrines, but in his discourses he appeared rather as a moral and religious teacher than as a philosopher. His doctrines approach more nearly to Christianity than those of any of the earlier Stoics, and although there is no trace in what is recorded of them of his having been directly acquainted with Christianity, it is at least probable that the ideas diffused by Christian teachers may have indirectly influenced them. The excellence of his system was universally acknowledged. When Domitian banished the philosophers from Rome (A.D. 94) Epictetus retired to Epirus, where he is supposed to have died. His disciple Arrian collected his opinions, which are preserved in two treatises called the *Discourses of Epictetus*, and the *Manual or Enchiridion*.

Epicure'an Philosophy. See *Epicurus*.

Epicu'rus, a Greek philosopher, founder of the Epicurean school, was born in the island of Samos B.C. 342, died at Athens B.C. 270. He settled at Athens B.C. 306, and purchased a garden in a favourable situation, where he established a philosophical school. Here he spent the remainder of his life, living in a simple manner and taking no part in public affairs. His pupils were numerous and enthusiastically devoted to him. His theory of the universe was based on the atomic theory of Democritus. The fundamental principle of his ethical system was that pleasure and pain are the chief good and evil, the attainment of the one and the avoidance of the other of which are to be regarded as the end of philosophy. He endeavoured, however, to give a moral tendency to this doctrine. He exalted the pure and noble enjoyments derived from virtue, to which he attributed an imperishable existence, as incalculably superior to the passing pleasures which disturb the peace of mind, the highest good, and are therefore detrimental to happiness. Peace of mind, based on meditation, he considered as the origin of all good. The philosophy of Epicurus has been violently opposed and frequently misrepresented; but while it is not open to the charges of gross sensualism which have been brought against it, it cannot be considered as much better than a refinement of sensualism. In ancient times his philosophy appears to have been more popular in Greece than in Rome, although his disciples were numerous in both, and the Latin poem of Lucretius, *De Rerum Natura*, is a poetical exposition of his doctrines. Epicurus was a very volu-

minous writer, but few of his writings are extant, what we possess comprising only some fragments of a 'Treatise on Nature, two letters, and detached passages. Lucretius, Cicero, Pliny, and Diogenes Laertius are our chief authorities for his doctrines.

Ep'icycle, in the ancient astronomy, a small circle supposed to move round the circumference of a larger, a hypothetical mode of representing the apparent motion of the planets, which were supposed to have such a motion round the circumference of a large circle, called the *deferent*, having the earth in its centre.

Epicy'cloid, in geometry, a curve generated by the movement of a circle upon the convex side of another curve, that generated by the movement of a circle upon the concave side of a fixed curve being called a *hypocycloid*.

Epicycloi'dal Wheel, a wheel or ring fixed to a framework, toothed on its inner side,

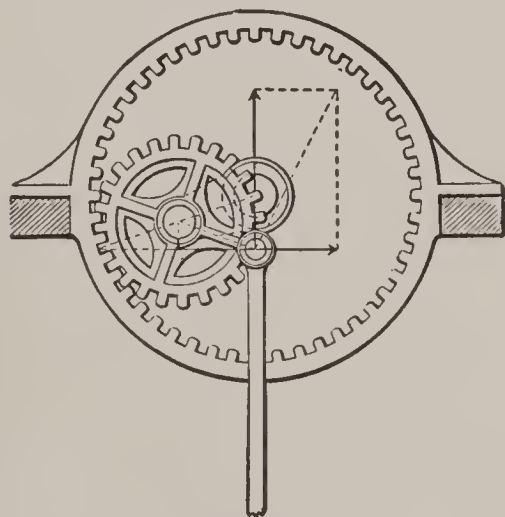

Epicycloidal Wheel.

and having in gear with it another toothed wheel of half the diameter of the first, fitted so as to revolve about the centre of the latter. It is used for converting circular into alternate motion, or alternate into circular. While the revolution of the smaller wheel is taking place any point whatever on its circumference will describe a straight line, or will pass and repass through a diameter of the circle, once during each revolution. In practice, a piston-rod or other reciprocating part may be attached to any point on the circumference of the smaller wheel.

Epidad'm'us. See *Durazzo*.

Epidau'rus, a town and seaport of ancient Greece, situated in Argolis, in the Peloponnesus, particularly celebrated for its magnificent temple of Æsculapius, which stood on

an eminence not far from the town. It had also temples of Artemis, Dionysus, Aphrodite, and Hera, and a splendid theatre still in fair preservation. The site is now occupied by the village *Epidauro*, where a congress met in 1822 and promulgated the 'Constitution of Epidaurus.'

Epidem'ic, or EPIDEMIC DISEASE (Gr. *epi*, upon, and *dēmos*, people), signifies a disease which attacks a people, suddenly spreading from one to the other in all directions, prevailing a certain time and then dying away. It usually travels from place to place in the direction of the most-frequented lines of communication. The reason is that such diseases are commonly due to some infective material capable of being conveyed from one individual to another, and of being transported from place to place. In Britain small-pox and cholera are occasionally epidemic, whilst scarlet fever, measles, chicken-pox, diphtheria, typhoid fever, &c., are almost invariably so. Certain diseases which appear to be more mental than physical sometimes occur so numerous as to assume an epidemic form, such as St. Vitus' dance, convulsionary diseases, suicidal mania, &c. See *Endemic*.

Epiden'drum (Gr. *epi*, upon, and *dendron*, a tree), a large genus of tropical American orchids, most of the species of which are epiphytic, growing on trees. There are upwards of 300 species. The stems are often pseudo-bulbs, the leaves are strap-shaped and leathery, and the flowers are single or in spikes, panicles, or racemes. The flowers are very handsome, and a large number of the species are in cultivation.

Epider'mis, in anatomy, the cuticle or scarf-skin of the body; a thin membrane covering the true skin of animals, consisting of two layers, an inner or mucous layer, called the *rete mucosum*, composed of active cells containing granules of colouring matter, and an outer or horny layer, consisting of flattened scale-like cells, dry, inactive, and effete, which are constantly being shed in the form of dust. Both layers are destitute of feeling, and of vessels or nerves.—The term is also applied to the cellular layer which covers the surface of plants, usually formed of a layer or layers of more or less compressed and flattened cells. It may be thin and soft or dense and hard, and has often appendages in the form of hairs, glands, &c.

Ep'idote, a mineral of a green or gray colour, vitreous lustre, and partial transparency,

a member of the garnet family. The primary form of the crystals is a right rhomboidal prism.

Epigæa (-jē'a), a genus of shrubs of the heath order, characterized by having three leaflets on the outside of the five-parted calyx; and by the corolla being salver-shaped, five-cleft, with its tube hairy on the inside. *E. repens*, the trailing arbutus, is the May-flower of N. America.

Epigastrium, EPIGASTRIC REGION (Gr. *epi*, upon, *gastēr*, the stomach), that part of the abdomen that lies over the stomach. See *Abdomen*.

Epiglottis, a cartilaginous plate behind the tongue, which covers the glottis like a lid during the act of swallowing, and thus prevents foreign bodies from entering the larynx. In its ordinary position during respiration it is pointed upwards, but in the act of swallowing it is pressed downwards and backwards by the drawing up of the windpipe beneath the base of the tongue, and thus closes the entrance to the air-passages. See *Larynx*.

Epigram (Gr. *epi*, upon, *graphein* to write), in a restricted sense, a short poem or piece in verse, which has only one subject, and finishes by a witty or ingenious turn of thought; in a general sense, a pointed or witty and antithetical saying. The term was originally given by the Greeks to a poetical inscription placed upon a tomb or public monument, and was afterwards extended to every little piece of verse expressing with precision a delicate or ingenious thought, as the pieces in the Greek anthology. In Roman classical poetry the term was somewhat indiscriminately used, but the epigrams of Martial contain a great number with the modern epigrammatic character.

Epigynous (e-pij'i-nus), in botany, growing on the top of the ovary or appearing to do so: said of stamens and petals.

Epilepsy (Greek *epilēpsia*, literally, a seizure), a nervous disease, the falling-sickness, so called because the patient falls suddenly to the ground. It depends on various causes, often exceedingly complicated and incapable of being removed; hence it is often an incurable periodical disease, appearing in single paroxysms. In its fully-developed form, convulsions, attended by complete unconsciousness, are the prominent feature. Among the different causes may be mentioned hereditary tendency, gastric disturbances, or some irritation within the skull itself, such as tumours,

&c. It is, for the most part, preceded by a tingling sensation, creeping up from the foot or hand to the breast and head, or some other premonitory symptom such as spectral illusions, headache, giddiness, confusion of thought, sense of fear, &c.; but sometimes there are no precursive symptoms. During the paroxysm all that is to be attended to is to prevent the patient from injuring himself; and this is to be accomplished by raising the head gently and loosening all tight parts of the dress. It is advisable to protect the tongue from being bitten by introducing a piece of india-rubber, cork, or soft wood between the teeth.

Epilobium, the willow-herb, a genus of plants, nat. order Onagraceæ. The species are herbs or under-shrubs with pink or purple, rarely yellow, flowers, solitary in the axils of the leaves or in terminal leafy spikes. The seeds are tipped with a pencil of silky hairs, and are contained in a long four-celled capsule. There are more than fifty species scattered over the arctic and temperate regions of the world, ten of them being natives of Britain.

Epilogue (Greek *epi*, upon, and *logos*, word, speech), the closing speech or short poem addressed to the audience at the end of a play. The epilogue is the opposite of the *prologue*, or opening address.

Epimachus (e-pim'a-kus), a genus of slender-billed (tenuirostral) birds of the hoopoe family, resembling the birds of paradise in the exceeding luxuriance and brilliancy of their plumage. See *Plume-bird*.

Epimenides (-dēz), an ancient Greek philosopher and poet, born in Crete in the 7th century before Christ. He was held for an infallible prophet, and by some is reckoned among the seven wise men, instead of Perander. He is supposed to be the prophet referred to by St. Paul in Titus, ch. i. 12.

Epimetheus (ep-i-mē'thūs), in Greek mythology, the brother of Prometheus and husband of Pandora. Epimetheus may be translated 'afterthought,' as Prometheus 'forethought.'

Épinal, a town of Eastern France, capital of the department of the Vosges, on the Moselle. It is well built and has handsome quays, an ancient Gothic church, a communal college, a public library of 20,000 vols., a museum, &c. The manufactures consist of articles in iron and brass, cutlery, earthenware, leather, oil, and chemicals. The famous paper-mills of Archettes are in the vicinity. Pop. 14,759.

Épinay, LOUISE FLORENCE PÉTRONILLE, MADAME D', French authoress, born in 1725, died 1783. She became the wife of M. Delalive d'Épinay, who filled the office of farmer-general. In 1748 she became acquainted with Rousseau, and gave him a cottage in which he passed many of his days. She was the author of *Les Conversations d'Emilie*, *Lettres à mon Fils*, and *Mes Moments heureux*. She left interesting memoirs and correspondence.

Epipha'nius, ST., was born in Palestine about 310, died 403. About 367 he was consecrated Bishop of Salamis or Constantia, in Cyprus. He was a zealous denouncer of heresy, and combated the opinions of Arius and Origen. His work *Panarion* gives the history, together with the refutation, of a great number of heresies. His festival is on the 12th of May.

Epiph'any (Greek, *epiphaneia*, a manifestation or showing forth), a festival, otherwise called the *manifestation of Christ to the Gentiles*, observed on the 6th of January in honour of the adoration of our Saviour by the three magi, or wise men, who came to adore him and bring him presents, led by the star. As a separate festival it dates from 813.

Ep'iphyte (Greek, *epi*, on, *phyton*, a plant), a plant which grows and flourishes on the trunks and branches of trees, adhering to the bark, as a moss, lichen, fern, &c., but which does not, like a parasite, derive any nourishment from the plant on which it grows. Many orchidaceous plants are epiphytes.

Epi'rus (Greek, *Epeiros*), a country of ancient Greece corresponding to the southern portion of modern Albania. The most interesting locality in it was Dodona (which see). The inhabitants were only in part Greeks. The Molossians at last acquired the ascendancy, and the kings of this tribe took the name of kings of Epirus. The most celebrated king of Epirus was Pyrrhus, who made war upon the Romans. Epirus became a Roman province in B.C. 168, and shared the fortunes of Rome till it was conquered by the Turks.

Epis'copacy, the system of church government in which bishops are established as distinct from and superior to priests or presbyters, there being in the church three distinct orders—deacons, priests, and bishops. See *Bishop*.

Ep'isode (Greek, *epeisodion*, something adventitious), an incidental narrative, or

digression in a poem, which the poet has connected with the main plot, but which is not essential to it.

Epistax'is, in medicine, a name for bleeding at the nose.

Epistemol'ogy (Greek, *epistēmē*, knowledge), that department of metaphysics which investigates and explains the doctrine or theory of knowing: distinguished from *ontology*, which investigates real existence or the theory of being.

Epis'tolæ Obscuro'rum Viro'rum ('Letters of Obscure Men') is the title of a collection of satirical letters which appeared in Germany in 1515-17, and professed to be the composition of certain ecclesiastics and professors in Cologne and other places. It is considered as one of the most masterly sarcasms in the history of literature, and its importance is enhanced by the effect it had in promoting the cause of the Reformation. The authorship of this satire has been a fertile subject of controversy, and is yet apparently far from being settled.

Ep'itaph (Greek, *epi*, upon, and *taphos*, tomb), an inscription upon a tomb or monument in honour or memory of the dead. Epitaphs were in use both among the Greeks and Romans. The Greeks distinguished by epitaphs only their illustrious men. Among the Romans they became a family institution, and private names were regularly recorded upon tombstones. The same practice has generally prevailed in Christian countries. On Christian tombstones epitaphs usually give brief facts of the deceased's life, sometimes also the pious hopes of survivors in reference to the resurrection or other doctrines of the Christian faith, &c. Many so-called epitaphs are mere witty *jeux d'esprit*, which might be described as epigrams, and which were never intended seriously for monumental inscriptions. The literature of the subject is very large.

Epithalamium (Gr. *epi*, on, and *thalamos*, a chamber), a nuptial song or poem in praise of a bride and bridegroom. Among the Greeks and Romans it was sung by young men and maids at the door of the bridal chamber of a new-married couple.

Epithelio'ma, epithelial cancer. See *Cancer*.

Epithe'lium, in anatomy, the cellular layer which lines the internal cavities and canals of the body, both closed and open, as the mouth, nose, respiratory organs, blood-vessels, &c., and which is analogous to the cuticle of the outer surface. There are sev-

eral varieties of epithelium. The epithelium lining the blood-vessels is called sometimes *endothelium*.

Epizo'a, a term applied to those parasitic animals which live upon the bodies of other animals, as lice, the itch-insect, &c.

Epizoöt'ic, or EPIZOÖTIC DISEASE, a disease that at some particular time and place attacks great numbers of the lower animals just as an epidemic attacks man. Pleuropneumonia is often an epizootic, as was also the rinderpest.

Epoch, or ERA, is a fixed point of time, commonly selected on account of some remarkable event by which it has been distinguished, and which is made the beginning or determining point of a particular year from which all other years, whether preceding or ensuing, are computed. The creation and the birth of Christ are the most important of the historical epochs. The creation has formed the foundation of various chronologies, the chief of which are: 1. The epoch adopted by Bossuet, Ussher, and other Catholic and Protestant divines, which places the creation in B.C. 4004. 2. The *Era of Constantinople* (adopted by Russia), which places it in B.C. 5508. 3. The *Era of Antioch*, used till A.D. 284, placed the creation B.C. 5502. 4. The *Era of Alexandria*, which made the creation B.C. 5492. This is also the *Abyssinian Era*. 5. The *Jewish Era*, which places the creation in B.C. 3760. The Greeks computed their time by periods of four years, called *Olympiads*, from the occurrence every fourth year of the Olympic games. The first Olympiad, being the year in which Coræbus was victor in the Olympic games, was in the year B.C. 776. The Romans dated from the supposed era of the foundation of their city (*Ab Urbe Condita*, A. U. C.), the 21st of April, in the third year of the sixth Olympiad, or B.C. 753 (according to some authorities B.C. 752). The *Christian Era*, or mode of computing from the birth of Christ as a starting-point, was first introduced in the 6th century, and was generally adopted by the year 1000. This event is believed to have taken place earlier, perhaps by four years, than the received date. The Julian epoch, based on the coincidence of the solar, lunar, and indictional periods, is fixed at 4713 B.C., and is the only epoch established on an astronomical basis. The *Mohammedan Era*, or *Hejira*, commences on 16th July, 622, and the years are computed by lunar months. The Chinese reckon their time by cycles of 60 years. Instead of numbering

them as we do, they give a different name to every year in the cycle. See *Chronology, Calendar*.

Epping, a village of England in Essex (giving name to a parl. div.), 17 miles from London, in the midst of an ancient royal forest which one time covered nearly the whole of Essex. The uninclosed portion has lately been secured to the public as a free place of recreation.

Eprouvette (ep-rö-vet'), the name of an instrument for ascertaining the strength of gunpowder, or of comparing the strength of different kinds of gunpowder.

Epsom, a town (giving name to a parl. div.) in the county of Surrey, England, 15 miles s.w. of London, formerly celebrated for a mineral spring, from the water of which the well-known Epsom salts were manufactured. The principal attraction Epsom can now boast of is the grand race meeting held on the Downs, the chief races being the Derby and Oaks (which see). Pop. 6916.

Epsom Salt, sulphate of magnesium ($Mg SO_4 7H_2O$), a cathartic salt which appears in capillary fibres or acicular crystals. It is found covering crevices of rocks, in mineral springs, &c.; but is commonly prepared by artificial processes from magnesian limestone by treating it with sulphuric acid, or by dissolving the mineral *kieserite* ($Mg SO_4 H_2O$) in boiling water, allowing the insoluble matter to settle, and crystallizing out the Epsom salt from the clear solution. It is employed in medicine as a purgative, and in the arts. The name is derived from its having been first procured from the mineral waters at Epsom.

Epworth, a small town of N. Lincolnshire, 9 miles N. of Gainsborough, the birth-place of John Wesley, the founder of Methodism. Pop. 2178.

Equation, in algebra, a proposition asserting the equality of two quantities, and expressed by the sign = between them; or an expression of the same quantity in two dissimilar terms, but of equal value; as, $3s. = 36d.$ or $x = b + m - r$. In the latter case x is equal to b added to m , with r subtracted, and the quantities on the right hand of the sign of equation are said to be the value of x on the left hand. An equation is termed *simple*, *quadratic*, *cubic*, or *biquadratic*, or of the first, second, third, or fourth degree, according as the index of the highest power of the unknown quantity is one, two, three, or four.

Equation, in astronomy, the correction or quantity to be added to or subtracted from the mean position of a heavenly body to obtain the true position. The term *personal equation* is the quantity of time by which a person is in the habit of noting a phenomenon wrongly; it may be called positive or negative, according as he notes it after or before it really takes place.

Equation of Payments, an arithmetical rule for the purpose of ascertaining at what time it is equitable that a person should make payment of a whole debt which is due in different parts, payable at different times.

Equation of Time, the difference between mean and apparent time, or the difference of time as given by a clock and as given by a sun-dial, arising chiefly from the varying velocity of the earth in its orbit and the eccentricity of the orbit. The sun and the clock agree four times in the year; the greatest difference between them at the beginning of November is fully sixteen minutes. See *Day*.

Equa'tor, that great circle of our globe every point of which is 90° from the poles. All places which are on it have invariably equal days and nights. Our earth is divided by it into the northern and southern hemispheres. From this circle is reckoned the latitude of places both north and south. There is also a corresponding celestial equator in the plane of the terrestrial, an imaginary great circle in the heavens the plane of which is perpendicular to the axis of the earth. It is everywhere 90° distant from the celestial poles, which coincide with the extremities of the earth's axis, supposed to be produced to meet the heavens. During his apparent yearly course the sun is twice in the celestial, and vertically over the terrestrial equator, at the beginning of spring and of autumn. Then the day and night are equal all over the earth, whence the name *equinox*.—The *magnetic equator* is a line which pretty nearly coincides with the geographical equator, and at every point of which the vertical component of the earth's magnetic attraction is zero; that is to say, a dipping needle carried along the magnetic equator remains horizontal. It is hence also called the *acclinic line*.

Equato'rial, an astronomical instrument contrived for the purpose of directing a telescope upon any celestial object, and of keeping the object in view for any length of time, notwithstanding the diurnal motion of the earth. For these purposes a prin-

cipal axis resting on firm supports is mounted exactly parallel to the axis of the earth's rotation, and consequently pointing to the poles of the heavens, being fixed so as to turn on pivots at its extremities. To this there is attached a telescope moving on an axis of its own in such a way that it may either be exactly parallel to the other axis, or at any angle to it; when at right angles it points to the celestial equator. By this means a star can be followed by one motion from its rising to its setting. In some observatories the equatorials have the necessary motion given them by clock-work.

Equer'ry, in Britain, the name of certain officers of the royal household, in the department of the master of the horse, whose duties consist in attendance when the sovereign rides abroad. Officers with the same denomination form part of the establishments of the members of the royal family.

Equestrian Order, the order of 'Knights' in ancient Rome. The *equites* or knights originally formed the cavalry of the army. They are said by Livy to have been instituted by Romulus, who selected 300 of them from the three principal tribes. About the time of the Gracchi (123 B.C.) the *equites* became a distinct order in the state, and the judges and the farmers of the revenue were selected from their ranks. They held their position in virtue of a certain property qualification, and towards the end of the republic they possessed much influence in the state. They had particular seats assigned to them in the circus and theatre, and the insignia of their rank, in addition to a horse, were a gold ring and a robe with a narrow purple border. Under the later emperors the order disappeared from the stage of political life.

Eq'uidæ, the horse family, a family belonging to the order Ungulata, or hoofed mammals, and subdivision Perissodactyla, characterized by an undivided hoof formed of the third toe and its enlarged horny nail, a simple stomach, a mane on the neck, and by six incisor teeth on each jaw, seven molars on either side of both jaws, and by two small canine teeth in the upper jaw of the males, and sometimes in both jaws. It is divided into two groups—one including the asses and zebras, the other comprising the true horses (genus *Equus*).

Equilib'rium, a state of equipoise; a state of rest produced by the mutual counteraction of two or more forces, as the state of the two ends of a lever or balance, when

both are charged with equal weight. When a body, being slightly moved out of any position, always tends to return to its position, that position is said to be one of *stable equilibrium*; when the body will not thus return to its previous position, its position is said to be one of *unstable equilibrium*.

Equinoc'tial, in astronomy, the circle in the heavens otherwise known as the celestial equator. When the sun is on the equator there is equal length of day and night over all the earth: hence the name *equinoctial*.—*Equinoctial gales*, storms which are observed generally to take place about the time of the sun's crossing the equator, that is, at the vernal and autumnal equinox, in March and September. (See *Equinox*.)—*Equinoctial points* are the two points wherein the celestial equator and ecliptic intersect each other; the one, being in the first point of Aries, is called the *vernal point*; and the other, in the first point of Libra, the *autumnal point*. These points are found to be moving backward or westward at the rate of 50'' of a degree in a year. This is called the *precession of the equinoxes*. See *Precession*.

Equinox, the precise time when the sun enters one of the equinoctial points, or the first point of Aries about the 21st of March, and the first point of Libra about the 23d of September, making the day and night of equal length all over the world. At all other times the lengths of the day and of the night are unequal, their difference being the greater the more we approach either pole, while in the same latitude it is everywhere the same. See *Equinoctial*.

Equise'tum, a genus of vascular cryptogamous plants with hollow-jointed stems, type of a nat. order the Equisetaceæ, growing in wet places, and popularly called *horse-tails*. See *Horse-tail*.

Eq'uites. See *Equestrian Order*.

Eq'uity, in law, the system of supplemental law administered in certain courts, founded upon defined rules, recorded precedents, and established principles, the judges, however, liberally expounding and developing them to meet new exigencies. While it aims to assist the defects of the common law, by extending relief to those rights of property which the strict law does not recognize, and by giving more ample and distributive redress than the ordinary tribunals afford, equity by no means either controls, mitigates, or supersedes the common law, but rather guides itself by its analogies, and does not assume any power to subvert its doc-

trines. Courts of equity grant redress to all parties where they have rights, *ex æquo et bono*, and modify and fashion that redress according to circumstances. They bring before them all the parties interested in the subject-matter of the suit, and adjust the rights of all.

Equity of Redemption, in law, the advantage allowed to a mortgager of a reasonable time to redeem an estate mortgaged, when it is of greater value than the sum for which it is mortgaged.

Equiv'alents, in chemistry, a term for the proportions in which the elements combine with one another to form compounds. See *Chemistry*.

Era. See *Epoch*.

Erard, SEBASTIEN, a celebrated musical-instrument maker, born at Strasburg in 1752, died 1831. He went to Paris at the age of eighteen, and in concert with his brother, Jean Baptiste, produced pianofortes superior to any that had previously been made in France. He afterwards established a manufactory in London, and made considerable improvements in the mechanism of the harp.

Eras'istratus, an ancient Greek physician, said to have been grandson of Aristotle. He lived in the 3d century before the Christian era, and was court physician of Seleucus Nicator, king of Syria. He was the first who systematically dissected the human body, and his description of the brain and nerves is much more exact than any given by his predecessors. He classified the nerves into nerves of sensation and of locomotion, and it is said had almost stumbled upon the discovery of the circulation of the blood. Of his works only the titles and some fragments remain.

Eras'mus, DESIDERIUS, a Dutch scholar, born at Rotterdam in 1467. His original name was Gerard, but this he changed according to a fashion of the time. After the death of his parents, whom he lost in his fourteenth year, his guardians compelled him to enter a monastery; and at the age of seventeen he assumed the monastic habit. The Bishop of Cambrai delivered him from this constraint. In 1492 he travelled to Paris to perfect himself in theology and polite literature. He there became the instructor of several rich Englishmen, from one of whom — Lord Mountjoy — he received a pension for life. He accompanied them to England in 1497, where he was graciously received by the king. He re-

turned soon after to the Continent, took his doctor's degree, was relieved from his monastic vows by dispensation from the pope, and published several of his works. He returned to England in 1510; wrote his *Praise of Folly* while residing with Sir Thomas More, and was appointed Margaret professor of divinity and Greek lecturer at Cambridge. In 1514 he returned to the Continent and lived chiefly at Basel, where he died in 1536. To extensive learning Erasmus joined a refined taste and a delicate wit. He rendered great and lasting



Desiderius Erasmus.

service to the cause of reviving scholarship. Although he took no direct part in the Reformation, and was reproached by Luther for lukewarmness, he attacked the disorders of monasticism and superstition, and everywhere promoted the cause of truth. He edited various classics, the first edition of the Greek Testament from MSS. (with Latin translation), &c., but his best-known books are the *Encomium Moriae*, or *Praise of Folly*, and his *Colloquies*. His letters are very valuable in reference to the history of that period.

Erastianism, the opinions of Erastus (which see).

Eras'tus, the learned name of Thomas Lieber, a Swiss physician, who maintained the opinions from which the well-known epithet of *Erastian*, as now used, is derived. He was born at Baden in 1523, and died at Basel 1584. He was successively professor of medicine at Heidelberg, and of ethics at

Basel. He maintained in his writings the complete subordination of the ecclesiastical to the secular power; and that the church had no right to exclude any one from church ordinances, or to inflict excommunication.

Er'ato, in Greek mythology, one of the Muses, whose name signifies loving or lovely. She presided over lyric and especially amatory poetry, and is generally represented crowned with roses and myrtle, and with the lyre in the left hand and the plectrum in the right in the act of playing.

Eratos'thenes, an ancient Greek astronomer, born at Cyrene, in Africa, B.C. 276, was librarian at Alexandria, and gained his greatest renown by his investigations of the size of the earth. He rendered much service to the science of astronomy, and first observed the obliquity of the ecliptic. Of the writings attributed to him one only remains complete,—*Katasterismoi*,—which treats of the constellations. He died about B.C. 194.

Er'bium, a rare metal found along with yttrium, terbium, and other rare elements, in some rare minerals. Its properties are but little known.

Ercilla y Zuñiga (er-thil'yá ē thö-nyé'gà), DON ALONSO DE, Spanish soldier and poet, born 1533, died 1595. He became page to the Infant Don Philip, accompanied him on his travels, and in 1554 went with him to England, on the occasion of his marriage with Queen Mary. After this he fought against the Araucanians of S. America (Chili), and his epic *La Araucana* is based on the events of this war. It was first published in 1569, is written in excellent Spanish, and occupies an honourable position in the national literature.

Erckmann-Chatrian (shát-ri-än), the joint name of two French-Alsatian writers of fiction. Émile Erckmann, born at Pfalzbourg 1822, studied law at Paris. Alexandre Chatrian, born at Soldatenthal, near Pfalzbourg, 1826, was for some time teacher in the Pfalzbourg College. They formed a literary partnership in 1847, but it was not till the appearance of *L'Illustre Docteur Mathéus* in 1859 that success attended them. Among their most popular books are *L'Ami Fritz*, *Le Fou Yégof*, *Madame Thérèse*, *Histoire d'un Conscrit* de 1813, *L'Histoire d'un Paysan*, *Waterloo*, *Le Plébiscite*, &c. Chatrian died Sept. 4, 1890.

Er'ebus, in the Greek mythology, the son of Chaos and Darkness. The name Erebus was also given to the infernal regions.

Erebus, MOUNT, a volcano of the antarctic regions in S. Victoria Land; height, 12,400 feet.

Erechtheus (e-rek'thūs), in Greek mythology, a personage associated with the early history of Athens, and to whom a fine temple, the *Erechthēum*, was built on the Acropolis.

Erection, LORDS OF, in Scots history, those private owners into whose hands the ecclesiastical estates belonging to the clergy had passed during the religious changes of the Reformation period.

Er'egli, EREKLI, the ancient *Heracleia*, a seaport of Asia Minor, on the Black Sea, prov. of Kastamuni, 128 miles E.N.E. of Constantinople. Pop. 5000.

Er'emite, a hermit or Anchorite. See *Anchorite*.

Er'furt, an important town in the Prussian province of Saxony, on the river Gera, formerly a fortress with two citadels, now given up as such. It has a fine cathedral dating from the 13th century and several handsome Gothic churches. The university, founded in 1378 and suppressed in 1816, was long an important institution. There are still a royal academy of science and a royal library with 60,000 vols. The monastery (now an orphanage) was the residence of Luther from 1501 to 1508. The town is in a very flourishing condition, and rapidly extending. The industries are varied, including clothing, machinery, leather, shoes, ironmongery, chemicals, &c. The horticulture of the environs enjoys a high reputation, plants and seed being produced for sale in great quantities. Pop. 1890, 72,360.

Er'got, the altered seed of rye and other grasses caused by the attack of a fungus called *Claviceps purpurea*. The seed is replaced by a dense homogeneous tissue largely charged with an oily fluid. In its perfect state this germinates and produces the *Claviceps*. When diseased rye of this kind is eaten a food for some time it sometimes causes death by a kind of mortification called dry gangrene. Ergot is used in obstetric practice to promote the contraction of the uterus.



1, Heads of Ergot (a a) produced on a grass. 2, *Claviceps purpurea* (b b) springing from the Ergot.

Erica (e-rī'ka), the heath, a large genus of branched rigid shrubs, type of the nat. order Ericaceæ, most of which are natives of South Africa, a few being found in Europe and Asia. The leaves are narrow and rigid, the flowers are globose or tubular, and four-lobed. Five species are found in Britain. See *Heath*.

Ericaceæ, a natural order of exogenous plants. See *Erica*.



Erica herbacea.

Er'icht, LOCH, a Scottish loch amid the Grampian Mountains, on the borders of Perth and Inverness-shires. It is 14½ miles long by about one mile broad, and joins Loch Rannoch by one outlet, and Loch Lydoch by another.

Er'icsson, JOHN, engineer, born in Sweden 1803. He served for a time in the Swedish army; removed to London in 1826, and to New York in 1839. He is identified with numerous inventions and improvements on steam machinery and its applications. His chief inventions are his caloric engine, the screw propeller (1836), which has revolutionized navigation, and his turret-ships, the first of which, the *Monitor*, distinguished itself in the American civil war, and inaugurated a new era in naval warfare. He latterly devoted himself to studies of the earth's motion and the intensity of solar heat. He died in 1889.

Erie (ē'ri), one of the great chain of North American lakes, between Lakes Huron and Ontario, about 265 miles long, 63½ miles broad at its centre, from 40 to 60 fathoms deep at the deepest part; area 9600 square miles. The whole of its southern shore is within the territory of the United States, and its northern within that of Canada. It receives the waters of the upper lakes by Detroit River at its south-western extremity, and discharges its waters into Lake Ontario by the Niagara River at its north-east end. The Welland Canal enables vessels to pass from it to Lake Ontario. It is shallow compared with the other lakes of the series, and is subject to violent storms. The principal harbours are those on the United States side—Buffalo, Erie, Cleveland, &c.

Erie, a city, Pennsylvania, U.S., an important railway and commercial centre on the southern shore of Lake Erie. There are numerous iron-works (including foundries, rolling-mills, blast-furnaces, &c.), petroleum refineries, breweries, tanneries, wood-working factories, &c. The harbour is one of the best on the lake. Pop. 40,634.

Erie Canal, the largest in the U.S., serving to connect the great lakes with the sea. It begins at Buffalo on Lake Erie, and extends to the Hudson at Albany. It is 363 miles long; has in all 72 locks; a surface width 70 feet, bottom width 42 feet, and depth 7 feet. It is carried over several large streams on stone aqueducts; cost nearly \$10,000,000, and was opened in 1825. The navigation is free.

Erigena (e-rij'e-na), JOANNES SCOTUS, an eminent scholar and metaphysician, probably born in Ireland about 800-810, died in France about 875. He spent a great part of his life at the court of Charles the Bald of France, and was placed at the head of the school of the palace. The king further imposed upon him the double task of translating into Latin the Greek works of the pseudo Dionysius the Areopagite, and of composing a treatise against Godeschalch on Predestination and Free-will. This treatise, and another, *De Divisione Naturæ*, contained many views in opposition to the teachings of the church. They were condemned by the councils of Valencia in 855 and of Langres in 859, and Pope Nicholas I. demanded the immediate disgrace of the culprit. His subsequent history is not known.

Erigeron (e-rij'é-ron), a genus of humble composite plants, of which *E. canadense* of America has diuretic properties.

Erina'ceus, a genus of animals, of which the hedgehog is the type. See *Hedgehog*.

Erin'na, a Greek poetess who lived about 600 B.C. She is said to have been an intimate friend of Sappho, and died at the age of eighteen. She acquired a high reputation for poetry; her chief work was called *Elakatē* (The Distaff), of which nothing has come down to us. An epitaph or two which are still extant, and believed by some to be hers, are by others deemed spurious.

Erinnyes (e-rin'i-ēz). See *Furies*.

Erioden'dron, the wool-tree, a genus of plants, nat. order Malvaceæ (mallows). There are eight species natives of America, but one belongs to Asia and Africa. The species are noble plants, growing from 50 to

100 feet high, having palmate leaves, and red or white flowers. The woolly coat of the seeds of some of the species is used in different countries for stuffing cushions and similar purposes.

Eriom'eter (Greek, *erion*, wool, *metron*, a measure), an optical instrument for measuring the diameters of minute particles and fibres, from the size of the coloured rings produced by the diffraction of the light in which the objects are viewed.

Erioph'orum. See *Cotton-grass*.

Eris, in the Greek mythology, the goddess of discord. Not being invited to the marriage of Peleus, she revenged herself by means of the *apple of discord*. See *Paris*.

Er'ith, a town of England, in Kent, on the Thames, about 14 miles east of London, a pleasant summer resort. Pop. 9812.

Er'ivan, a Russian town, capital of government of the same name in the lieutenancy of the Caucasus, on the Sanga, north of Mount Ararat. It has a citadel, barracks, a cannon foundry, and some manufactures. Pop. 12,505. The government has an area of 10,705 sq. miles, and a pop. of 583,957.

Erlang'en, a town of Bavaria, 10 miles N.N.W. of Nürnberg. The Protestant university, founded in 1743, is the chief institution. The industries include cotton spinning and weaving, mirrors, hosiery, gloves, combs, &c. Pop. 15,814.

Erlau, or **EGER**, a town, Hungary, on the Eger, 65 miles E.N.E. of Budapest. It has sundry manufactures; and the red wines of the district, esteemed the best in Hungary, are largely exported. Pop. 20,669.

Erl-king, the English form of the name given in German and Scandinavian poetical mythology to a personified natural power which devises and works mischief, especially to children. Goethe's celebrated poem *Der Erlikönig* (lit. 'elf-king') has rendered this malicious spirit universally known.

Er'mine, the stoat, a quadruped of the weasel tribe (*Mustēla Erminēa*), found over temperate Europe, but common only in the north. In consequence of the change that



Wool-tree (*Eriodendron anfractuosum*).

occurs in the colour of its fur at different seasons—by far most marked in the Arctic regions—it is not generally known that the ermine and stoät are the same. In winter, in cold countries or severe seasons, the fur changes from a reddish-brown to a yellowish-white, or almost pure white, under which



Ermine (*Mustela Erminea*).

shade the animal is recognized as the ermine. In both states the tip of the tail is black. Like many other species of this genus the ermine has the faculty of ejecting a fluid of a musky odour. Its fur is short, soft, and silky; the best skins being brought from Russia, Sweden, and Norway, and Hudson bay territories. It was formerly one of the insignia of royalty, and is still used by judges. When used as linings of cloaks the black tuft from the tail is sewed to the skin at irregular distances.—In heraldry, ermine is one of the furs, represented with its peculiar spots black on a white ground.

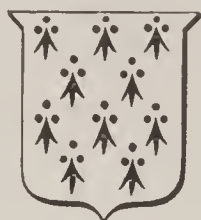

Ermine.

Erne (érn), the name often given to all the eagles of the genus *Haliaëtus*, but more specifically to the white-tailed sea-eagle. See *Sea-eagle*.

Erne, LOUGH, a lake, Ireland, county Fernanagh, consisting of a north or lower, and a south or upper lake (with the town of Enniskillen between), connected by a narrow winding channel, and properly forming only expansions of the river Erne. Its entire length is about 40 miles; average breadth 6 miles. It contains numerous small islands, and is well stocked with fish.—The river Erne rises in Lough Gounagh, in the county of Longford, flows through Loughs Oughter and Erne, and falls into Donegal Bay below Ballyshannon. Length, 72 miles.

Ernest Augustus, King of Hanover and Duke of Cumberland, was the fifth son of George III.; born 1771, died 1851. He became a field-marshal in the British army,

and on the death of William IV. in 1837 he ascended the throne of Hanover, in consequence of the succession to the sovereignty of that country being limited to male heirs. He was succeeded by his son, George V., the last of the Hanoverian kings.

E'ros, the Greek name of Cupid and Amor.

Erosion Theory, in geology, the theory, now held by all geologists, that valleys are due to the wearing influences of water and ice, the latter chiefly in the form of glaciers, as opposed to the theory which regards them as the result of fissures in the earth's crust produced by strains during its upheaval.

Erot'ic (from the Gr. *erōs*, love), relating to love.—*Erotic Poetry*, amatory poetry.—The name of *erotic* writers has been applied, in Greek literature, particularly to a class of romance writers, and to the writer of the Milesian Tales.

Erotoma'nia, mental alienation or melancholy caused by love.

Erra'ta (Lat. the plural form of *erratum*, an error), the list of errors and corrections placed at the end or at the beginning of a book.

Errat'ics, or **ERRATIC BLOCKS**, in geology, boulders or large masses of angular rock which have been transported to a distance from their original mountains by the action of ice during the glacial period. Thus on the slopes of the Jura Mountains immense blocks of granite are found which have travelled 60 miles from their original situation. Similarly masses of Scotch and Lake-district granites and of Welsh rocks (some of which weigh several tons) occur not uncommonly in the surface soil of the Midland counties of England.

Ersch (ersh), **JOHN SAMUEL**, German bibliographer, born 1766, died 1828. He was principal librarian and professor of geography and statistics at Halle. Among his publications are a Dictionary of French Writers; a Manual of German Literature; and, in connection with Gruber, the Universal Encyclopædia of Arts and Sciences (Leipzig, 1818, et seq. 4to).

Erse, a name sometimes given to Gaelic.

Ers'kine, **EBENEZER**, the founder of the Secession Church in Scotland, born 1680, died 1756. He studied at Edinburgh, and was ordained minister of Portmoak, in Fife, in 1703, in which situation he continued for twenty eight years, when he removed to Stirling. His attitude towards patronage and other abuses in the church led to his

being deposed, when, in conjunction with his brother and others, he founded the Secession Church. He is the author of several volumes of sermons.

Erskine, THE HON. HENRY, Scottish barrister, was the third son of Henry David, tenth earl of Buchan; born at Edinburgh 1746, died 1817. After studying at the universities of St. Andrews, Edinburgh, and Glasgow, he adopted the legal profession, and in 1768 was called to the bar. He twice held the office of lord-advocate, was for long the leader of the Scottish bar, and held a high reputation as a wit.

Erskine, JOHN, of Carnock, afterwards of Cardross, Scottish jurist, born 1695, died 1768. He was called to the Scotch bar in 1719, and was author of *Principles of the Law of Scotland*, and the *Institute of the Law of Scotland*, both works of authority.

Erskine, RALPH, brother of Ebenezer Erskine, born 1685, died 1752. He was ordained to the parish of Dunfermline in 1711, and in 1737 joined his brother, who had seceded from the Established Church. His *Gospel Sonnets* and other religious works were once very popular.

Erskine, THOMAS, Lord Erskine, Scottish lawyer, the youngest son of the tenth earl of Buchan, was born in 1750, and died in 1823. He was educated partly at the High School of Edinburgh, and partly at the University of St. Andrews. After serving four years in the navy and seven in the army he commenced the study of law, and in 1778 both took his degree at Cambridge and was called to the bar. His success was immediate. In May, 1783, he received a silk gown, and the same year was elected member of parliament for Portsmouth, a seat he held till 1806, when he was raised to the peerage. The rights of juries he firmly maintained on all occasions, but particularly in the celebrated trial of the Dean of St. Asaph for libel. In 1789 he defended Mr. Stockdale, a bookseller, for publishing what was charged as a libellous pamphlet in favour of Warren Hastings. In 1792, being employed to defend Thomas Paine, when prosecuted for the second part of his *Rights of Man*, he declared that, waiving all personal convictions, he deemed it right, as an English advocate, to obey the call: by the maintenance of which principle he lost his office of attorney-general to the Prince of Wales. In the trials of Hardy, Tooke, and others for high treason in 1794, which lasted for

several weeks, the ability displayed by Erskine was acknowledged by all parties. He was a warm partisan of Fox, and a strenuous opposer of the war with France. In 1802 the Prince of Wales not only restored him to his office of attorney-general, but made him keeper of his seals for the Duchy of Cornwall. On the death of Pitt, in 1806, Erskine was created a peer, and raised to the dignity of lord-chancellor. During his short tenure of office the bill for the abolition of slavery was passed. After he retired with the usual pension he took little part in politics.

Eruptive Rocks, in geology, those which, like lava, basalt, granite, &c., have broken through other rocks while in a molten state.

Eryn'go (*Eryngium*), a genus of plants belonging to the natural order Umbelliferae. There are upwards of 100 species found in temperate and sub-tropical climates, but chiefly in South America. *E. maritimum*, also called sea-holly, is the only truly native British species. It frequents sandy shores, and is distinguished by its rigid, spiny, glaucous, veined leaves, and its dense heads of blue flowers. The roots are sometimes candied, and are reputed to be stimulating and restorative, as well as to have aphrodisiac properties. *E. campestre* was formerly much employed in Europe as a tonic, and as tending to promote appetite. *E. aquaticum* is an American species known by the name of rattlesnake weed.

Erys'imum, a genus of plants, nat. order Cruciferae, chiefly biennials, with narrow entire leaves, and yellow, often fragrant, flowers. There are about 100 species, natives of northern temperate and cold countries. *E. cheiranthoides*, a native of Europe and N. America, is found in waste places in the south of England, and from being used as an anthelmintic, is called worm-seed.

Erysip'elas, the rose, or St. Anthony's fire, a disease characterized by diffused inflammation of the skin of some part of the body, but chiefly of the face or head, and attended by fever. It is, generally, an acute affection, its medium duration being from ten to fourteen days. It should be treated by nourishing food and iron tonics, the parts being protected from cold.

Erythe'ma, a mild form of inflammation of the skin somewhat resembling erysipelas. Some forms are connected with constitutional diseases, as rheumatism, gout, &c.

Erythræ'a, a genus of annual herbs, of which *Centaury* is the best-known species.

Erythræ'an Sea, in ancient geography, a name given to what is now called the Indian Ocean, but including the Persian and Arabian Gulfs. The name was latterly restricted to the Arabian Gulf.

Erythri'na, the coral-tree, a genus of trees with bright-red flowers. See *Coral-tree*.

Erythro'nium, a genus of liliaceous plants, natives of temperate regions, nearly stemless herbs, with two smooth shining flat leaves, and large generally reddish flowers, which are solitary. They have a long narrow, solid, scaly bulb. One of them is dog's-tooth violet.

Erythrophlœ'um, a genus of tropical trees, nat. order Leguminosæ, containing three species, two found in Africa, and the third in Australia. The *E. guineense* of Guinea has a poisonous juice, which is used by the natives as a test of innocence and guilt, and hence the name ordeal-tree.

Erythroxy læ, Erythroxy laceæ, a nat. order of exogenous plants, having alternate stipulate leaves, small pallid flowers, and drupaceous fruit. The principal genus is *Erythroxy lon*, some of whose species have a bright-red wood (hence the name—*Gr. erythros*, red, *xylon*, wood), occasionally used for dyeing. For *E. Coca* see *Coca*.

Eryx, an ancient city and a mountain in the west of Sicily, about 2 miles from the sea-coast. The mountain, now Monte San Giuliano, rises direct from the plain to a height of 2184 feet. On the summit anciently stood a celebrated temple of Venus. All traces of the ancient town of Eryx have now disappeared, and its site is occupied by the modern town of San Giuliano.

Erzerum, ERZEROU, or ERZEROU (er'-ze-röm), a city of Turkish Armenia, capital of a vilayet with an area of 27,000 sq. miles, and a pop. of 582,745. The town is about 6000 ft. above sea-level, forms an important strategical centre, and has become a principal frontier fortress. It is irregularly built, its narrow dirty streets, flanked by mean houses, being crowded together in the small space inclosed by its lofty walls. The Moslem element prevails largely over the Christian, although it is the metropolis of the Armenian church in union with Rome. In addition to important manufactures, especially in copper and iron, it carries on an extensive trade, and is a chief halting-place for Persian pilgrims on their way to Mecca. Pop. 38,894.

Erzgebirge (erts'ge-bir-ge; 'Ore Mountains'), a chain of European mountains form-

ing a natural boundary between Saxony and Bohemia, nearly 120 miles in length and 25 miles broad. The highest summits, which are on the side of Saxony, rise to 3800 or 3900 feet. The mountains are rich in silver, iron, copper, lead, cobalt, arsenic, &c.

Esarhad'don, the son of Sennacherib, and one of the most powerful of all the Assyrian monarchs. He extended the empire on all sides, and is the only Assyrian monarch who actually reigned at Babylon. He died about 667 B.C. See *Assyria*.

E'sau, the eldest son of Isaac, and twin-brother of Jacob. His name (which signifies rough, hairy) was due to his singular appearance at birth, being 'red, and all over like an hairy garment.' The story of his marriage, of his loss of birthright through the craft of Rebekah and Jacob, and of his quarrel and reconciliation with Jacob, are told in the book of Genesis. He was the progenitor of the Edonites, who dwelt on Mount Seir.

Escanaba, a city, in Delta co., Mich., at north end of Green Bay, has a good harbor; shipping large amounts of iron ore. Pop. 1890, 6808.

Escape'ment, the general contrivance in a time-piece by which the pressure of the wheels (which move always in one direction) and the vibratory motion of the pendulum or balance-wheel are accommodated the one to the other. By this contrivance the wheelwork is made to communicate an impulse to the regulating power (which in a clock is the pendulum and in a watch

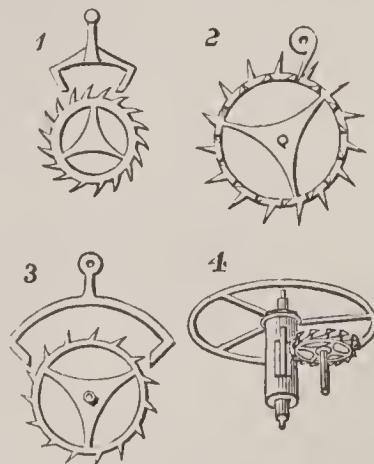

Watch and Clock Escapements.

1, Anchor escapement of a common clock. 2, Duplex escapement. 3, Lever escapement. 4, Horizontal or cylinder escapement.

the balance-wheel), so as to restore to it the small portion of force which it loses in every vibration, in consequence of friction and the resistance of the air. The leading requisite of a good escapement is that the impulse communicated to the pendulum or balance-wheel shall be invariable, notwithstanding any irregularity or foulness in the train of wheels. Various kinds of escapements have been contrived, some of which are shown

in the accompanying figure. See also *Clock, Watch*.

Es'car, ES'KAR, a late geological formation in the superficial drift, generally consisting of a long linear ridge of sand and gravel, including pieces of considerable size. The materials are derived from the waste of till or boulder-clay, and their arrangement took place probably under water over which icebergs floated, for in Sweden particularly angular, erratic blocks are often deposited on the *escar*. They are called in Scotland *Kaims* or *Kames*.

Escarp', in fortification. See *Scarp*.

Eschalot (esh'a-lot). See *Shallot*.

Eschar (es'kâr), a slough or portion of dead or disorganized tissue. The name is commonly applied to the crust or seal occasioned on the skin by burns or caustic applications.

Escharot'ics, substances that cause an eschar (which see).

Eschatol'ogy (es-ka-), in theol. the 'doctrine respecting the last things,' which treats of the millennium, the second advent of Christ, the resurrection, judgment, conflagration of the world, and the final state of the dead.

Escheat (es-chēt'), in law, a species of reversion arising from default of heirs or by forfeiture. That which falls or lapses to the original proprietor, or to the State, as lands or other property. By modern legislation there can be no escheat on failure of the whole blood wherever there are persons of the half-blood capable of inheriting.

Eschenbach (esh'en-bâh), WOLFRAM VON, German mediæval poet or minnesinger, flourished in the first half of the 13th century. The most esteemed of his numerous works are: *The Parzival* (printed 1477); *the Titu-rel, or the Guardian of the Graal* (printed 1477); and *the Willehalm*, a poem on the deeds of William of Orange, a contemporary of Charlemagne.

Eschscholtzia (esh-sholt'si-a), a small genus of glabrous whitish plants, of the poppy order, natives of California and the neighbouring regions. They have divided leaves, and yellow peduncled flowers. The sepals cohere and fall off as the flower opens in the form of a calyptra. They are now common in the gardens of Great Britain.

Eschwege (esh'vā-ge), a town of Prussia, province of Hessen-Nassau, on the Werra, 26 miles E.S.E. of Cassel. Pop. 9492.

Eschweiler (esh'vī-lër), a town of Prussia, in the province of Rheinland, 9 miles E.N.E.

of Aix-la-Chapelle, on the Inde. It is the seat of large and varied manufacturing industries, especially in iron, copper, and zinc, and has coal-mines. Pop. 16,889.

Escobar y Mendoza (es-ko-bär' ē mendō'thâ), ANTONIA, a Spanish casuist and Jesuit, born 1589, died 1669. His principal works are *Summula Casuum Conscientiæ* and several scriptural commentaries. He was severely criticised by Pascal, and the extreme laxity of his moral principles was ridiculed by Boileau, Molière, and La Fontaine.

Escrow', a legal writing delivered to a third person to be delivered by him to the person whom it purports to benefit, when some condition is performed. Upon the performance of this condition it becomes an absolute deed, but if the condition be not performed it remains an *escrow* or scroll.

Escu'rial (Spanish, *el Escorial*), a remarkable building in Spain, comprising at once a palace, a convent, a church, and a mausoleum. It is distant from Madrid about 24 miles in a north-westerly direction, and situated on the acclivity of the Sierra Guadarrama, the range of mountains which divides New from Old Castile. It was built by Philip II., and dedicated to St. Lawrence, in commemoration of the victory of St. Quentin, fought on the festival of the saint in 1557. It is popularly considered to be built on the plan of a gridiron, from the fact that St. Lawrence is said to have been broiled alive on a sort of large gridiron. The building is a rectangular parallelogram measuring 744 feet in length by 580 in breadth. The interior is divided into courts, formerly inhabited by monks and ecclesiastics, while a projection 460 feet in length (the handle of the gridiron) contains the royal palace. It was begun in 1563 and finished in 1584. It is of moderate height, and its innumerable windows (said to be 11,000) give it (apart from the church) somewhat the aspect of a large mill or barracks. The church is the finest portion of the whole building. The dome is 60 feet in diameter, and its height at the centre is about 320 feet. Under it is the Pantheon or family vault of the Spanish sovereigns. The library contains a valuable collection, including a rich store of Arabic MSS. The Escurial was partly burned in 1671, when many MSS. were destroyed, and was pillaged by the French in 1808 and 1813. It was restored by Ferdinand VII., but the monks, with their revenues which supported

it, have long since disappeared. In 1872 it was fired by lightning, and suffered serious damage.

Escutcheon, in heraldry, the shield whereon coats of arms are represented. See *Heraldry*.

Esdraë'lon, PLAIN OF, a plain extending across Palestine from the Mediterranean to the Jordan, and drained by the river Kishon. Among its subsidiary valleys are those of Engannin, Taanach, and Megiddo. This plain is celebrated for many important events in Old Testament history.

Esdras, BOOKS OF, two apocryphal books, which, in the Vulgate and other editions, are incorporated with the canonical books of Scripture. In the Vulgate the canonical books of Ezra and Nehemiah are called the first and second, and the apocryphal books the third and fourth books of Esdras. The Geneva Bible (1560) first adopted the present nomenclature, calling the two apocryphal books first and second Esdras. The subject of the first book of Esdras is the same as that of Ezra and Nehemiah, and in general it appears to be copied from the canonical Scriptures. The second book of Esdras is supposed to have been either of much later date, or to have been interpolated by Christian writers.

Esk (Celtic for water), the name of two small rivers in England—one in Cumberland and one in Yorkshire; and of several in Scotland, the chief being the Esk in Dumfriesshire; the North Esk and South Esk in Forfarshire; and the North Esk and South Esk in Edinburghshire.

Es'kar. See *Escar*.

Eski-jumna, town of Bulgaria, on the northern slope of the Binar-Dagh. Pop. 10,000.

Eskilstu'na, a town of Sweden, on river of same name connecting Lake Maelar with Lake Hjelm, with iron-works and manufactures of steel goods, weapons, &c. Pop. 8286.

Es'kimos. See *Esquimaux*.

Eski-Sagra, a town of Eastern Roumelia, on the south slope of the Balkans, 50 miles N.E. of Philippopolis. It has in its vicinity extensive gardens of roses, numerous orchards, and mineral springs. Pop. 13,000.

Eski-Shehr, a town of Asiatic Turkey, 90 miles S.E. of the Sea of Marmora, with warm baths and manufactures of meerscham pipes from the deposits of that substance in the neighbourhood. Pop. 10,000.

Esmarch (es'märk), JOHANNES FRIED-

RICH AUGUST, German surgeon; born 1823. He held high official positions during the Schleswig-Holstein and Franco-German wars; is a great authority on gun-shot wounds; has originated valuable improvements in barrack-hospitals, ambulances, &c.; and is the author of several surgical works.

Es'neh, a town of Upper Egypt, on the left bank of the Nile, 28 miles S.S.W. of Thebes, capital of a province of same name, on the site of the ancient Latopolis. Among the

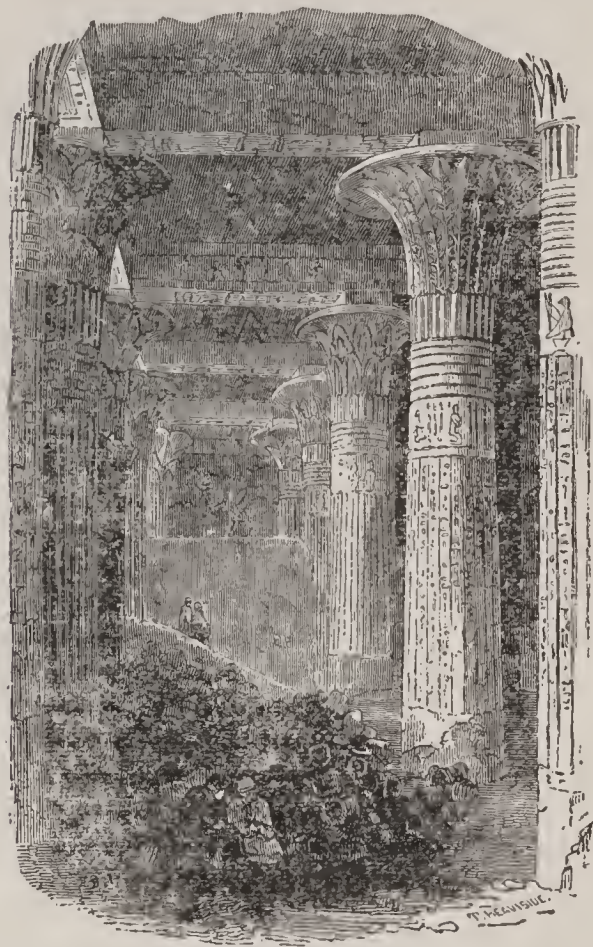

Interior of Temple, Esneh.

ruins there is a beautiful portico of twenty-four lofty and massive columns, belonging to a temple of Kneph (the only portion of the temple cleared out), and erected in the Ptolemaic and Roman period, with a zodiac on the ceiling. Esneh is the entrepôt of the Senaar caravans; has manufactures of cottons, pottery, &c.; and is reckoned the healthiest place in Egypt. Pop. 7000.

Esoc'idæ, the family of fishes to which the true pike (*Esox lucius*) belongs, as also the mascalonge (*E. nobilior*) of America.

Esop. See *Æsop*.

Espalier, in gardening, a sort of trellis-work on which the branches of fruit trees or bushes are extended horizontally, with the object of securing for the plant a freer

circulation of air as well as a full exposure to the sun. Trees thus trained are not subjected to such marked nor so rapid variations of temperature as wall-trees.

Espartero (es-pâr-tâ'rō), BALDOMERO, Duke of Vittoria, a Spanish statesman, born 1792, died 1879. The son of a wheelwright, he was educated for the priesthood, but joined the army as a volunteer in 1808. He took a leading part in the conflict with the Carlists, and was one of the most prominent men in Spain during several decades of the present century. He was regent of the kingdom in 1841-43, and again head of the government in 1854-56. He was exiled in England for several years (1843-47). In 1868 his name was vaguely put forward in the Cortes as a candidate for the throne, but the proposal fell flat, and the closing years of his life were spent in retirement.

Espar'to, a plant growing in Spain and N. Africa, long applied to the manufacture of cordage, matting, &c., and now extensively used for paper-making. This plant, called by botanists *Stipa* or *Macrochlōa tenacissima*, is a species of grass 2 to 4 feet high, covering large tracts in its native regions, and also cultivated, especially in Spain. Formerly the supply of esparto was almost wholly obtained from Spain, but it is now obtained in still larger quantity from Algeria (where it is called *alfa*), and from Tripoli and Tunis. The paper made from it is excellent; it may be also reduced to a fibrous state and used for stuffing mattresses, &c.

Espinasse. See *L'Espinasse*.

Espir'ito-Santo ('Holy Spirit'), a maritime province, Brazil, bounded north by Bahia, south by Rio-de-Janeiro; length, about 260 miles; breadth, about 120 miles; area, 43,290 square miles. Pop. 121,560.

Espir'itu-Santo, an island of the Pacific, the largest of the New Hebrides, with some 20,000 inhabitants.

Esplanade', in fortification, the wide open space left between a citadel and the nearest houses of the city. The term is also frequently applied to a kind of terrace, especially along the sea-side, for public walks or drives.

Esquimault (es-kē'mält), a harbour and naval station on the south-east coast of Vancouver Island, about 3 miles from Victoria, the capital of British Columbia. The harbour is almost landlocked, and with the 'Royal Roads' outside, is capable of giving safe anchorage to a fleet of vessels of the

largest size. It is the station of H.M. ships on the Pacific coast, and is being fortified and provided with all the necessaries of a first-class naval arsenal.

Esquimaux (es'ki-mōz), or **ESKIMOS**, a race inhabiting the Arctic coasts of North America, from Greenland to Behring's Strait, and extending into Asia. They call themselves *Inu-it*, the people; their other name is from an Algonquin word signifying eaters of raw flesh. They consist of three principal stocks—the Greenlanders; the Esquimaux proper, in Labrador; and the Western Esquimaux, found along Hudson's Bay, the west side of Baffin's Bay, the polar shores as far as the mouths of the Coppermine and Mackenzie rivers, and both on the American and Asiatic sides of Behring's Strait. Their leading physical peculiarities are a stunted stature, flattened nose, projecting cheek-bones, eyes often oblique, and yellow and brownish skin. Seal-skins, reindeer and other furs are used as materials for dress, according to the season, as well as skins of otters, foxes, martins, &c. In summer they live in tents, covered with skins; in winter they may be said to burrow beneath the snow. In Greenland houses built of stone and cemented with turf are used as permanent habitations. Vegetation being extremely stunted within the limits of their territories, their food consists of the flesh of whales, seals, walrus, &c., often eaten raw; and they show remarkable skill in fishing and hunting. Their weapons are bows and arrows, spears or lances, generally pointed with bone, but sometimes with metal. Their only domestic animal is the Esquimaux dog (which see). In intellect they are by no means deficient; in manners they are kind and hospitable. Their religious ideas appear scanty, but success has attended the labours of the Danish missionaries in teaching them the Christian religion.

Esquimaux Dog, or **ESKIMO DOG**, a breed of dogs extensively spread over the northern regions of America and of Eastern Asia. It is rather larger than the English pointer, but appears less on account of the shortness of its legs. It has oblique eyes, an elongated muzzle, and a bushy tail, which give it a wolfish appearance. The colour is generally a deep dun, obscurely barred and patched with darker colour. It is the only beast of burden in these latitudes, and with a team of such dogs attached to his sledge the Eskimo will cover 60 miles a day for several successive days.

Es'quire (old Fr. *escuyer*, from L. *scutum*, a shield); originally, a shield-bearer or armour-bearer; an attendant on a knight; hence in modern times a title of dignity next in degree below a knight. In England this title is properly given to the younger sons of noblemen, to officers of the king's courts and of the household, to counsellors at law, justices of the peace while in commission, sheriffs, gentlemen who have held commissions in the army and navy, &c. It is usually given to all professional and literary men, and nowadays, in the addresses of letters, *esquire* may be put as a complimentary adjunct to almost any person's name. In heraldry the helmet of an esquire is represented sideways, with the vizor closed.

Esquiros (es-kē-ros), HENRI ALPHONSE, French poet, romancist, and miscellaneous writer, born at Paris 1814, died at Versailles 1876. His first work, a volume of poetry, *Les Hirondelles*, appeared in 1834. This was followed by numerous romances, and a commentary on the life of Christ: *L'Évangile du Peuple*, for which he was prosecuted and imprisoned. He then published *Les Chants d'un Prisonnier*, poems written in prison; *Les Vierges Folles*; *Les Vierges Sages*; *L'Histoire des Montagnards*; &c. Having to leave France in 1851 he resided for years in England, and wrote a series of essays for the *Revue des Deux Mondes* on English life and character, which were translated under the title of *The English at Home*, and were very popular. He also wrote a similar work on the Dutch.

Es'say, a composition in which something is attempted to be proved or illustrated, usually shorter and less methodical and finished than a systematic or formal treatise; so that it may be a short disquisition on a subject of taste, philosophy, or common life. Caution or modesty has induced many writers of note to give the title of essay to their most elaborate productions: thus we have Locke's *Essay on the Human Understanding*. There is a class of English writers to whom the descriptive term *essayist* is applied. The *Spectator*, *The Tatler*, *The Rambler*, and many other extensive collections of brief treatises embracing every variety of subjects are among the works of this class of writers.

Essays and Reviews, a volume written by six Church of England clergymen and one layman, viz., Dr. Temple (afterwards successively Bishop of Exeter, and London), Dr. Rowland Williams, Baden Powell, H.

B. Wilson, Mark Pattison, Prof. Jowett, and Mr. C.W. Goodwin, and published in March, 1860. Its alleged heterodoxy caused much excitement, and called forth numerous replies, condemnation by convocation in 1864, and the prosecution of two of the writers by the ecclesiastical courts.

Essek. See *Eszek*.

Essen, a town of Rhenish Prussia, 18 miles north-east of Düsseldorf, founded in the 9th century, and adorned with a fine church dating from 873. It has recently increased with great rapidity, and is celebrated for the steel and iron works of Krupp, the most extensive in Europe, employing about 20,000 workmen. This great establishment was started in 1827, with only two workmen. The works occupy 1000 acres, and the firm possesses coal and iron-stone mines. The rifled steel cannon made here are supplied to most of the armies of Europe. In the Krupp works there is now a steam-hammer of 150 tons. Pop. 78,706.

Essences, solutions of the volatile or essential oils in spirits. See *Essential Oils*.

Essenes (es-sēnz'), or ESSÆANS, a sect among the Jews, the origin of which is unknown, as well as the etymology of their name. It appears to have sprung up in the course of the century preceding the Christian era, and disappeared on the dispersion of the Jews after the siege of Jerusalem. The sect appears to have been an outcome of Jewish mysticism and asceticism, which gradually assumed the form of a distinct organization. They were remarkable for their strictness and abstinence, and had a rule of life analogous to that of a monastic order.

Essential Oils, volatile oils usually drawn from aromatic plants by subjecting them to distillation with water, such as the oils of lavender, cloves, peppermint, &c.

Essequibo (es-se-kē'bō), a river of British Guiana, which flows into the Atlantic by an estuary 20 miles in width after a course of about 450 miles. The district or division of Essequibo is well cultivated and extremely fertile, producing coffee, cotton, cocoa, and sugar. Pop. 36,000.

Essex, a maritime county in the S.E. of England, bounded by Suffolk, the Thames, Hertford, and Middlesex; area is 987,032 acres. The surface is generally level, except in the N.W., where it is undulating and sometimes hilly. The soil is in general extremely fertile, and particularly well adapted for the growth of wheat. Beans and pease

also thrive uncommonly well. The other principal productions are potatoes, barley, oats, mangolds, turnips, tares, rape, mustard, and trefoil. The raising of caraway, coriander, and teazel is almost peculiar to this county. It had formerly a great extent of forest, the only survival of which is Epping Forest. The principal rivers in the county are the Roding, Crouch, Chelmer, Blackwater, Colne, &c. It has also the Thames, Lea, and Stour as boundary rivers. On the coast are some valuable oyster-beds, the oysters from which are exported in considerable quantities. The manufactures of the county are not very extensive, the chief being crape, silks, straw plait, &c. The chief towns are Chelmsford, the county town; West Ham, Colchester, Maldon, and Harwich. The county has eight parliamentary divisions, each returning one member. Pop. 1891, 785,399.

Essex, EARL OF. See *Cromwell, Thomas*.

Essex, ROBERT DEVEREUX, SECOND EARL OF, was born in 1567. Having appeared at court, he soon became a favourite of Queen Elizabeth, by whom he was kept in attendance against his will during the danger of the Armada. He served with more or less distinction in expeditions to Portugal and France, the latter on behalf of Henry of Navarre. In 1596 he was commander of the troops in an expedition against Spain, and distinguished himself by the capture of Cadiz. In an expedition next year he was less fortunate, and the queen, with whom he was always quarrelling, received him coldly. Presuming on the favour of Elizabeth he behaved with rudeness to her at a privy-council and received a box on the ear, and was told to 'go and be hanged.' After some months a reconciliation took place, and he was appointed Lord-lieutenant of Ireland (1599), which was then in a state of rebellion. He returned to England in September, having been entirely unsuccessful in his government. He was made a prisoner in his own house, and foolishly tried to excite an insurrection in London. After a skirmish with a party of soldiers he was compelled to surrender, and sent to the Tower. He was tried for treason on 19th February, and executed on the 26th February, 1601.

Esslingen (es'ling-ën), a town of Germany, in Würtemberg, on the Neckar, 7 miles E.S.E. of Stuttgart. It is of Roman origin, was long an imperial free town, has walls flanked with towers, a castle, and an

ancient Gothic church, with a tower 236 feet high. It has manufactures of machinery, articles of wood, cutlery, philosophical instruments, spinning and other mills, &c. Pop. 1890, 22,234.

Es-souan. See *Assouan*.

Established Church, a church having a form of doctrine and government established by law in any country for the teaching of Christianity within its boundaries, and usually endowed by the state. The upholders of the establishment theory maintain that it is the duty of a state to provide for the religious instruction of the people. On the other hand, it is argued that the state has no right to endow or support any particular sect or denomination, unless they assume that that denomination alone is possessed of religious truth and worth. Regarding the established *Church of England* see under *England*, and *Church of Scotland* under *Scotland*.

Estafette (es-ta-fet'), a courier who carries his message in conjunction with others by relay.

Estaminet (es-tä-mi-nā; French), a café where smoking is permitted.

Estan'cia, an estate or farm in Spanish South America, especially one on which cattle are reared.

Estate, the interest or quantity of interest a man has in lands, tenements, or other effects. Estates are *real* or *personal*. *Real estate* comprises lands, tenements, and hereditaments, held in freehold. *Personal estate* comprises interests for terms of years in lands, tenements, and hereditaments, and property of every other description. *Real estate* descends to heirs; *personal* to executors or administrators. In ordinary language, an estate is a piece of landed property; a definite portion of land in the ownership of some one.

Estates of Scotland, the name given to a body of similar constitution to the English Parliament, but with important differences, the king himself, as well as his officers, being responsible to the estates for wrongs done. They held the power of declaring war, or entering on a peace or treaty, and with them rested the right of declaring, with or without the consent of the king, resolutions of the assembly to be law. To prevent a bill being hurried through parliament it was submitted to and discussed by a committee called the *Lords of the Articles*. If sanctioned by this committee the bill was passed on to the whole house for approval. An-

other committee appointed by the estates was called the *Auditors of Complaints*, whose duty was to hear appeals against the decisions of the king's judges, and, if necessary, to reverse their sentences.

Estates of the Realm, in Britain, are the lords spiritual, the lords temporal, and the commons. From the circumstance that the lords spiritual and temporal meet in one house, and practically form one branch of the legislature, the popular error has arisen that the sovereign forms one of the three estates of the realm.

Este (es'tā), a town of North Italy, 16 miles s.w. of Padua. It has a castle, the cradle of the Este family. Manufactures of silk goods, earthenware, and majolica; numerous silk-mills and whetstone quarries. Pop. 10,640.

Este (es'tā), one of the most ancient and illustrious families of Italy. In the 11th century the house of Este became connected by marriage with the German Welfs or Guelphs, and founded the German branch of the house of Este, the dukes of Brunswick and Hanover. The sovereigns of Ferrara and Modena were of this family, several of them being famous as patrons of letters. The lives of Boiardo, Ariosto, and Tasso were closely connected with members of this house. The last male representative of the Estes died in 1798. His daughter married a son of the German emperor Francis I., and her grandson disappeared from the land of his forefathers at the consummation of Italian unity in 1860.

Estella (es-tel'yà), a town of N.E. Spain, in Navarre, on the Ega, 24 miles south-west of Pampeluna. Pop. 6749.

Este'pa, a town of Southern Spain, prov. of Seville, 50 miles east by south of Seville. It has a handsome Gothic church. Pop. 8190.

Estepo'na, a seaport of Southern Spain, prov. of Malaga, 23 miles north-east of Gibraltar. Pop. 9994.

Esterha'zy, a family of Hungarian magnates, whose authentic genealogy goes back to the first half of the 13th century. They were zealous partisans of the house of Hapsburg, to whom, during the reigns of Frederick II. and Leopold I., they lent a powerful support. Among the more prominent members of the family are—PAUL IV., PRINCE ESTERHAZY, a general and literary *savant*, 1635–1713. His grandson, NICHOLAS JOSEPH, a great patron of arts and music, founder of the school in which Haydn and

Pleyel, among others, were formed, 1714–90. NICHOLAS, PRINCE ESTERHAZY, distinguished as a field-marshal and foreign ambassador, 1765–1833. PRINCE PAUL ANTHONY, a distinguished and able diplomatist, born 1786, died 1866; was successively Austrian ambassador at Dresden, Rome, and Britain. He was a supporter of the national Hungarian movement.

Esther, a Jewess, who became the queen of Ahasuerus (see *Ahasuerus*), King of Persia, and whose story is told in the book of the Old Testament called by her name. This book is supposed by some to be the composition of Mordecai himself, the uncle of the heroine. Various opinions are held regarding the time and truth of the story; but the feast of Purim which commemorates the events narrated is still observed by the Jews during the month Adar.

Esthonia, a maritime government of Russia, bounded by the Gulf of Finland, the Baltic, and the governments of Livonia and St. Petersburg. It includes several islands, of which the most important are Dagoe and Oesel; area, about 7610 square miles. It has for the most part a flat or undulating surface. The whole of the north side, however, rises considerably above the sea, and presents to it ranges of cliffs. The Narva, which merely bounds the government on the east, is the only river of any importance; but minor streams, as well as small lakes, are very numerous. About a fourth of the surface is covered with forests of pine, birch, and alder. The crops include a little wheat, much barley and oats, and some flax, hops, and tobacco. Cattle are reared, and active fisheries are carried on. The peasantry are almost all of Finnish origin, and speak a Finnish dialect. In the 10th and 12th centuries it belonged to Denmark, it was afterwards annexed by Sweden, and in 1710 was seized by Russia. Revel is the capital. Pop. 392,738.

Estivation. See *Æstivation*.

Estop'pel, in law, anything done by a party himself, which puts a period to an action by closing the ground of controversy.

Esto'vers, in law, necessities or supplies. *Common of estovers* is the liberty of taking the necessary wood for a house or farm from another's estate.

Estrad'iot, an Albanian dragoon or light-horseman, employed in the French army in the 15th and 16th centuries. They sometimes fought on foot as well as on horseback.

Estremadu'ra, a western division of Spain, consisting of the provinces of Badajoz and Caceres. It is fertile, but not cultivated to its full extent. The Tagus and Guadiana intersect it east to west. Immense flocks of sheep graze on the rich plains. The area is about 16,700 sq. miles, and the pop. 818,211.

Estremadura, a maritime province of Portugal, divided by the Tagus into two nearly equal parts, of which the northern is the more mountainous. Wines and olives are the principal produce. The principal city is Lisbon. Area, 6876 sq. miles. Pop. 946,472.

Estremez', or **ESTREMOZ'**, a town of Portugal, in the province of Alemtejo, 22 miles west from Elvas. Pop. 7577.

Es'tuary, the wide mouth of a river opening out so as to form an arm of the sea.

Eszek (es-sek'), or **ESSEG**, a strongly-fortified town of Austro-Hungary, on the Drave, 13 miles from its confluence with the Danube. It has barracks, town-house, normal school, &c., an important trade, and several fairs. Pop. 18,201.

Etæ'rio, **ETERIO**, in bot. a collection of distinct indehiscent carpels, either dry upon a fleshy receptacle as the strawberry, or dry upon a dry receptacle as the ranunculus, or fleshy upon a dry receptacle as the raspberry, the parts being small drupes.

Etampes (ā-tānp), a town of France, dep. Seine-et-Oise, 30 miles s. by w. from Paris. Pop. 7465.

Etap'pen (Ger.), a department in continental armies the business of which is to relieve the commanders of the field army of all responsibility for their communications in the rear. The officers of this department supervise all arrangements for loading and unloading at stations, forwarding, feeding, billeting, &c.

Eta'wah, a town, Hindustan, N.W. Provinces, capital of the district of same name, on left bank of the Jumna, picturesquely situated among ravines, and richly planted with trees. It has some good buildings, and a considerable trade. Pop. 34,721. The district has an area of 1694 square miles, and a pop. of 722,371.

Etching, the art of producing designs upon a plate of steel or copper by means of lines drawn with an *etching-needle* (a fine-pointed steel tool), the lines being drawn through a coating or varnish (the *ground*), and *bitten in* by some strong acid which can only affect the plate where the varnish has been removed. See *Engraving*.

Etchmiadzin. See *Armenia*.

Ete'ocles and **Polyni'ces**, two heroes of ancient Greek legend, sons of Oedipus, king of Thebes. After their father's banishment from Thebes, Eteocles usurped the throne to the exclusion of his brother, an act which led to an expedition of Polynices and others against Thebes. The two brothers fell by each other's hand. See *Antigone*.

Ete'sian Winds, winds blowing at stated times of the year; applied especially to northerly and north-easterly winds which prevail at certain seasons in the Mediterranean regions.

Eth'elbert, King of Kent, born about 560, died 616. He succeeded his father, Hermenric, and reduced all the Anglo-Saxon states, except Northumberland, to the condition of his dependants. Ethelbert married Bertha, the daughter of Caribert, king of Paris, and a Christian princess, an event which led indirectly to the introduction of Christianity into England by St. Augustine. Ethelbert was the first Anglo-Saxon king to draw up a code of laws.

Ethelbert, King of England, son of Ethelwulf, succeeded to the government of the eastern side of the kingdom in 857, and in 860, on the death of his brother Ethelbald, became sole king. His reign was much disturbed by the inroads of the Danes. He died in 866.

Eth'elred I., King of England, son of Ethelwulf, succeeded his brother Ethelbert in 866. The Danes became so formidable in his reign as to threaten the conquest of the whole kingdom. Ethelred died in consequence of a wound received in an action with the Danes in 871, and was succeeded by his brother Alfred.

Ethelred II., King of England, son of Edgar, born 968, succeeded his brother, Edward the Martyr, in 978, and, for his want of vigour and capacity, was surnamed *the Unready*. In his reign began the practice of buying off the Danes by presents of money. After repeated payments of tribute he effected, in 1002, a massacre of the Danes; but this led to Sweyn gathering a large force together and carrying fire and sword through the country. They were again bribed to depart; but, upon a new invasion, Sweyn obliged the nobles to swear allegiance to him as King of England; while Ethelred, in 1013, fled to Normandy. On the death of Sweyn he was invited to resume the government, and died at London in the midst of his struggle with Canute (1016).

Eth'elwulf, King of England, succeeded his father, Egbert, about 837; died 857. His reign was in great measure occupied in repelling Danish incursions; but he is best remembered for his donation to the clergy, which is often quoted as the origin of the system of tithes.

Eth'endun, BATTLE OF, the victory which Alfred the Great gained over the Danes (878), and which led to the treaty with Guthrum, the Danish king of East England. The locality is doubtful.

E'ther, a hypothetical medium of extreme tenuity and elasticity supposed to be diffused throughout all space (as well as among the molecules of which solid bodies are composed), and to be the medium of the transmission of light and heat.

Ether, in chem. a very light, volatile, and inflammable fluid, produced by the distillation of alcohol with sulphuric acid. It is lighter than alcohol, of a strong sweet smell, susceptible of great expansion, and has a pungent taste. A mixture of vapour of ether with atmospheric air is extremely explosive. Its formula is $(C_2H_5)_2O$. Ether produces an intoxication of short duration, and is sometimes used as an anæsthetic.

Etherege (eth'é-rej), SIR GEORGE, English writer of comedy, was born about 1636. He studied at Cambridge, travelled afterwards on the Continent, and then returned to enter himself at one of the Inns of Court. But he devoted himself less to legal studies than to literature and society. In 1664 he had his first comedy represented, *The Comical Revenge*, or, *Love in a Tub*, which was well received. Four years later his *She Would if She Could*, appeared, a brilliant play though frivolous and immoral. Eight years afterwards (1676) he produced his best comedy, *The Man of Mode*, or *Sir Fopling Flutter*. *Etherege's* plays are witty and sparkling, and the characters, genuine portraits of the men and women he saw, are vividly if lightly drawn. He died about 1688.

E'therene. See *Ethylene*.

Eth'ics, otherwise called *Moral Philosophy* or *Morals*, is the science which treats of the nature and laws of the actions of intelligent beings, considered as to whether they are *right* or *wrong*, *good* or *bad*. The science is more or less closely connected with theology, psychology, politics, political economy, and jurisprudence, but what most strictly belongs to it is the investigation of the principles and basis of duty or the moral law, and an inquiry into the nature and origin

of the faculty by which duty is recognized. Various answers have been given to the question why we call an action good or bad, such as that it is consistent or not with the will of God, or with the nature of things, or with the greatest happiness of the greatest number, or that an inward faculty decides it to be such or such; and a great variety of *ethical* systems have been proposed. The foundations of the leading systems were laid in antiquity, the names of Socrates, Plato, Aristotle, Epicurus, the Cynics and the Stoics being especially prominent. The introduction of Christianity brought a new element into ethical speculation, and among Christians ethics were intimately associated with theology, and morality was regarded as based on and regulated by a definite code contained in the sacred writings. The speculations of the Greeks were not, however, disregarded, and some of the ablest Christian moralists (as Augustine, Peter Lombard, Erigena, Anselm, Aquinas, &c.) endeavoured to harmonize the Greek theories with the Christian dogmatics. Most modern ethical systems consider the subject as apart from theology and as based on independent philosophical principles, and they fall into one of two great classes—the utilitarian systems, which recognize as the chief good, happiness, or the greatest possible satisfaction of the tendencies of our nature; and the rationalistic systems, which recognize that ideas of law and obligation can have their source only in reason. The first of the modern school in England was Hobbes (1588-1679). Among subsequent names are those of Cudworth, Locke, Clarke, Shaftesbury, Butler, Hutcheson, Hume, Adam Smith, Reid, Paley, Whewell, Bentham, J. S. Mill, &c. Among those who maintain the utilitarian theory of morals is Paley, who holds that men ought to act so as to further the greatest possible happiness of the race, because God wills the happiness of men, and rewards and punishes them according to their actions, the divine commands being ascertained from Scripture and the light of nature. Bentham's utilitarianism is considerably different from Paley's. It was entirely dissociated from theology or Scripture, and maintained that increase of happiness ought to be the sole object of the moralist and legislator, pleasure and pain being the sole test of actions. To utilitarianism as a special development belong the later 'evolution ethics' represented by Mr. Herbert Spencer, in which biological con-

ceptions, such as 'the preservation of the human race,' take the place of the Benthamite criterion for determining what is good and bad in actions. Another theory of ethics places the moral principle in the sentimental part of our nature, that is, in the direct sympathetic pleasure or sympathetic indignation we have with the impulses which prompt to action or expression. By means of this theory, which he treats as an original and inexplicable fact in human nature, Adam Smith explains all the phenomena of the moral consciousness. In considering the systems which recognize that the ideas of law and obligation can have their source only in reason, the question, what is the source of the laws by which reason governs, gives rise to a number of psychological theories, amongst which we may notice Clarke's view of the moral principles as rational intuitions or axioms analogous to those of mathematics; Butler's theory of the natural authority of conscience; the position of Reid, Stewart, and other members of the later intuitional school, who conceive a moral faculty implanted in man which not only perceives the 'rightness' or 'moral obligation' of actions, but also impels the will to perform what is seen to be right. Very similar as far as classification goes, is the position of Kant, who holds that reason recognizes the immediate obligation of certain kinds of conduct, and that an action is only good when done from a good motive, and that this motive must be essentially different from a natural inclination of any kind.

Ethiopia, or ÆTHIOPIA (Hebrew, *Cush*), in ancient geography, the country lying to the south of Egypt, and comprehending the modern Nubia, Kordofan, Abyssinia, and other adjacent districts; but its limits were not clearly defined. It was vaguely spoken of in Greek and Roman accounts as the land of the *Ichthyophagi* or fish-eaters, the *Macrobii* or long-livers, the *Troglodytes* or dwellers in caves, and of the *Pygmies* or dwarf races. In ancient times its history was closely connected with that of Egypt, and about the 8th century B.C. it imposed a dynasty on Lower Egypt, and acquired a predominant influence in the valley of the Nile. In sacred history Ethiopia is repeatedly mentioned as a powerful military kingdom (see particularly Isaiah xx. 5). In the 6th century B.C. the Persian Cambyses invaded Ethiopia; but the country maintained its independence till it became tributary to the Romans in the

reign of Augustus. Subsequently Ethiopia came to be the designation of the country now known as Abyssinia, and the Abyssinian monarchs still call themselves rulers of Ethiopia.

The *Ethiopian Language*, or more accurately the *Geez* language, is the old official and ecclesiastical language of Abyssinia, introduced into that kingdom by settlers from South Arabia. In the 14th century it was supplanted as the language of the Christian church of Abyssinia by the Amharic. It is a Semitic language resembling Aramaic and Hebrew as well as Arabic. It has a Christian literature of some importance. The principal work is a translation of the Bible, including the Old and New Testaments and Apocrypha, to which are appended some non-canonical writings, such as the Shepherd of Hermas and the Book of Enoch. The language is to some extent represented by the modern dialects of Tigre, and by that spoken by some nomadic tribes of the Soudan. For the Ethiopian or Abyssinian Church, see *Abyssinia* and *Copt*.

Ethiops Mineral, the black sulphide of mercury, prepared by rubbing mercury and sulphur together, either hot or cold.

Eth'moid Bone, a light spongy bone situated between the orbital processes at the root of the nose. The olfactory nerves shoot down through its numerous perforations to the nose.

Ethnology and Ethnography, sciences treating of man, the former analysing the social phenomena of mankind as shown in their customs, languages, institutions, &c.; the latter being more concerned with descriptive details and the orderly collection of facts relating to particular tribes and localities. Besides these terms there is the term *Anthropology*, used by some to indicate the general science or natural history of mankind, of which the other two are parts. Here we can only give a few particulars bearing on the strictly ethnological and ethnographic divisions of the subject. (As to the place of man in the animal kingdom see *Man*.) The unity or plurality of species of the human race is a question which has given rise to much discussion. The most common view has probably been that which regards all mankind as descended from Adam and Eve, attributing the great differences exhibited by different races to climate and other causes acting for a long period of time. Many have held that such differences were not to be so accounted for, and that

the various typical races of the earth were not descended from a single pair, but were separately created in separate localities. The belief that man may have originated from a single pair is supported by the researches of Darwin, who has shown how an accumulation of differences amounting to the appearance of a distinct species may arise from continual modifications of a single primordial form. (See *Species*.) Certainly amongst men the variability of the same race under different climatic conditions is very striking. Even within a comparatively small period of time physical surroundings have induced typical differences between the lithe, sparely-fleshed Yankee of New England and the plump, rosy-cheeked Englishman; and the Boer of South Africa, with its dry climate, has developed a type as decidedly different from his original stock in moist Holland. The theory of the development of the human race from a single species demands a vast duration of time; and the flint implements discovered intermingled with remains of the mammoth and other extinct animals have proved that man was a contemporary of the mammoth, the cave bear, and other mammalia of the geological period antecedent to our own, though how distant that period was as measured by thousands of years it is difficult to say. Another interesting point is in regard to the first home of the human race. This of course is quite uncertain, but probably it was either in Western Asia or in Africa, and we may naturally conclude that where the mammalia of the highest characteristics appear there was the possible birthplace and centre of distribution of mankind.

When we attempt to classify mankind we can scarcely find any one physical characteristic belonging exclusively to a single race. At most we can only say that certain characteristics are the preponderant ones in certain races. In seeking racial characteristics ethnologists make use of various principles of classification. Some give the first place to the shape of the head. Camper, the Dutch anatomist, was the first who attempted to make a scientific distinction of races on this principle, taking as the basis of measurement the amount of the facial angle. (See *Facial Angle*.) But Camper's method, though it illustrates excellently the great differences which exist, between, say, the anthropoid apes with an angle of 42° , the African negro with an angle of 70° , and the European with an angle of 80° , is without certainty, it being

possible to find in the population of a single large town as wide variations of the facial angle as exist between distinct races. Camper's method was therefore superseded by the method of Blumenbach, which is based on consideration of all the chief distinctions in shape of the head according to which he classified the human family into five varieties: the Caucasian, Mongolian, Ethiopian, Malay, and American. These five varieties were cut down to three by Cuvier, who treated the Malay and American as subdivisions of the Mongolian; and extended by Dr. Prichard, who divided the Caucasian class into a Semitic and an Aryan or Indo-European class. Latham's classification was into 1. Mongolidæ (Chinese, Turks, Malays, American races, &c.); 2. Atlantidæ (African races, Jews and Arabs); 3. Japetidæ (Indo-Europeans). Amongst the later attempts made to find a new principle of classification we may mention that of Retzius, based on the relative length and breadth of the skull, according to which mankind are divided into *Dolichocephalic* or long-skulled and *Brachycephalic* or short, broad-skulled races. Later developments of craniology have introduced a third class, the *Mesocephalic*, representing a mean between the other two. The general rule for measurement is that the longitudinal diameter being rated as 100, the lateral diameter is expressed in a percentage of these units. If the index of breadth is from 74 to 78 the skull is termed mesocephalous; if below 74 it is dolichocephalous, a narrow or long skull; if it reaches 79 it is brachycephalous, a broad or short skull. The capacity of the brain cavity is also a favourite method with some ethnologists. Here the European stands highest with 92.1 cubic inches; the Australian lowest with 81.7. The character of hair and colour of skin has also been used by Huxley as the basis of his classification, which divides mankind into 1. *Ulotrichi*, crisp or woolly haired people with yellow or black skin, comprising Negroes, Bushmen, and Malays; 2. *Leiotrichi*, smooth-haired people, subdivided into Australioid, Mongoloid, Xanthochroic (fair whites), and Melanochroic (dark whites) groups. But many ethnologists hesitate to accept a classification which brings together nations apparently unrelated, such as the Australians, the ancient Egyptians, and the tribes of Southern India. On the other hand, the character of the hair is found to be one of the surest tests in separating neighbouring races, such as the Papuan, and the Ma-

layan and Australian tribes. Oscar Peschel's classification, based on a number of different particulars, such as the shape of the skull, the colour of the skin, the nature and colour of the hair, the shape of the features, &c., is as follows:—

1. *The Australians*.—Characters: skull of the dolichocephalic type, the jaws being also prognathous or protruded. The nose is narrow at the root, widening greatly below. The mouth is wide and unshapely. The body is thickly covered with hair; the hair is black, elliptical in section, that on the head being frizzly, and standing out so as to form a shaggy crown. The colour of the skin is dark as a rule, sometimes black, though a light copper-red also occurs.

2. *The Papuans*.—This race, which is the one most closely allied to the Australians, occupies New Guinea, New Caledonia, the Solomon Islands, New Hebrides, the Fiji Islands, &c. The most distinctive mark is their peculiarly flattened and abundant hair, growing in tufts, and forming a spreading crown round the head. The skin is always dark, the skull high and narrow (dolichocephalic); the jaws prognathous; the lips fleshy and somewhat swollen; the nose hooked somewhat after the Jewish type.

3. *The Mongoloid Nations*.—To this race belong the Polynesian and Asiatic Malays, the people of South-eastern and Eastern Asia, the Tibetese, all the Northern Asiatics, with their kinsmen in Northern Europe, and lastly the aboriginal population of America. The common characteristics are: long straight hair, circular in section; almost complete absence of beard and body hair; skin dark-coloured, varying from leather-yellow to deep brown, sometimes inclining to red; prominent cheek-bones, and eyes in general set obliquely. The various members of the Mongoloid race may be classed under the following subdivisions: (a) *The Malay race*, comprising the Malays of Malacca, Sumatra, Java, &c., the inhabitants of Madagascar, the New Zealanders, the natives of the Sandwich Islands, &c. (b) *Southern Asiatics with monosyllabic languages*, comprising the Chinese, Indo-Chinese (Burmese, Siamese, Anamese, &c.), Tibetese, &c. (c) *Coreans and Japanese*. (d) *Northern Mongoloids of the Old World*, comprising the true Mongols, Turks, Finns, Lapps, Magyars, Bulgarians, &c., all much resembling the Chinese and Indo-Chinese group in physical characters. (e) *Northern*

Nations of doubtful position.—The Yenisei Ostiaks, the Ainos of Yesso, the inhabitants of Saghalien, &c. (f) *The Behring's Nations*, of which the Esquimaux, or Eskimo, are the most important. (g) *The American Aborigines* or Red Indians.

4. *The Dravidians or Aborigines of India*.—These tribes have the skin generally very dark, frequently quite black; their hair is long and black, not straight but crimped or curly; the hair of beard and body grows profusely; the lips are thick and fleshy, somewhat like those of the negroes, but the jaws are never prominent. The Dravidians comprise the Tamuls, Telugus, Gonds, Santals or Sonthals, &c.

5. *The Hottentots and Bushmen*.—These are tribes of little importance inhabiting South Africa. They have the hair tufted and matted, the beard scanty, the body almost hairless; the lips are full, but not so much so as with the negroes; the nose is of the snub shape; the opening of the eyes is narrow but not oblique. They are slimly built, and the Bushmen in particular low in stature; their colour is yellowish or yellowish-brown.

6. *The Negroes*.—The negroes inhabit Africa from the southern margin of the Sahara to the territory of the Hottentots and Bushmen, and from the Atlantic to the Indian Ocean. They display great variety in external characteristics, and what is popularly considered the typical negro is rarely met with. The colour of the skin passes through every gradation, from ebony-black to dark brown, copper-red, olive, or yellow. In some tribes the nose is straight, in others hooked, though often broad and flat. The hair of the head is generally short, elliptic in section, and much crimped; that on the body is not plentiful; whiskers are comparatively rare. The negroes may be divided into the Bantu negroes (including the Kaffirs, Bechuanas, &c.) and the Soudan negroes, these divisions being based on differences in language. It is in the Soudan region that the most typical members of the negro race are found.

7. *The Mediterranean Nations*.—These include all Europeans who are not Mongoloids, the North Africans, all Western Asiatics, and the Hindus. Among them are the highest members of the human race. The northern nations have the skin quite fair; the southern have it darker; in North Africa and Eastern Asia it becomes yellow, red, or brown. The nose has always a high

bridge; prognathism and prominence of the jaws and cheek-bones are rare; the lips are never intumescent, and in no other race are refined and noble features so frequent. Subdivisions are: (a) *The Hamites*, comprising the ancient Egyptians, the Copts of Egypt and the Nubians, the Berbers and Gallas. (b) *The Semites*.—These comprise the Jews, Arabs, and Abyssinians, and the ancient Canaanites, Assyrians, Babylonians, and Phœnicians. (c) *The Indo-European or Aryan family*.—This family is divided into two branches, a European and an Asiatic. The European comprises the Germanic or Teutonic nations (English, Germans, Dutch, Danes, Norwegians, Swedes, &c.), the Romance nations (French, Italians, Spaniards, Portuguese), the Slavonians (Russians, Bohemians, Servians, &c.), the Greeks, and lastly the Celts. The Asiatic comprises the Hindus, Afghans, Persians, Armenians, and Kurds. (d) *Europeans of doubtful position*.—These include the Basques of the north-east of Spain and south-west of France and various tribes in the Caucasus.

Eth'yl is the name given to the radicle C_2H_5 , which is contained in ether and alcohol. It is a colourless gas, which is liquefied by moderate cold and pressure, and which burns with a brilliant white flame.

Eth'ylamine, an organic base formed by the substitution of ethyl for all or part of the hydrogen of ammonia. It has the odour and many of the reactions of ammonia.

Eth'ylene. See *Olephant Gas*.

Étienne (ā-ti-ān), **ST.**, a town of Southern France, dep. Loire, on the Furens, 32 miles s.w. of Lyons. It has spacious streets with substantial houses, but owing to the number of public works presents a dingy appearance. The principal buildings and institutions are the cathedral, an ancient Romanesque structure; the town-house, court-house, exchange, communal college, mining school, gallery of arts, library, and museum. The town stands in the centre of one of the most valuable mineral fields of France; and in addition to the extensive collieries, blast-furnaces, and other ironworks in the vicinity, has manufactures of ribbons, silks, cutlery, firearms, &c. The collieries alone employ about 16,000 men. Pop. 1891, 133,443.

Etiolation (Fr. *étioler*, to blanch), or **BLANCHING** of plants, is a state produced by the absence of light, by which the green colour is prevented from appearing. It is effected artificially, as in the case of celery, by raising up the earth about the stalks of

the plants; by tying the leaves together to keep the inner ones from the light; by covering with pots, boxes, or the like, or by setting in a dark place. The green colour of etiolated plants may be restored by exposure to light.

Etiquette (et'i-ket), a collective term for the established ceremonies and usages of society, from the forms which are to be observed in particular places such as courts, levees, and public occasions, to the general forms of polite society. Amongst courts the Byzantine and Spanish courts, and the French court under Louis XIV. and XV., have been noted for the strictness of their etiquette. Social etiquette consists in so many minute observances that a tolerable familiarity with it can be acquired only by a considerable intercourse with polite society. It is often said that all that is necessary to constitute good social manners is common sense and good feeling; but not to mention those formal rules of society which, though intrinsically worthless, demand a certain amount of respect, there are also many difficulties and emergencies in social intercourse which require peculiar tact and delicacy of judgment. Hence quickness of sympathy and a certain fineness of observation are more needed for proficiency in this sphere than pure power of intellect.

Etive (et'iv), **LOCH**, an inlet of the sea on the west coast of Scotland, county Argyll, nearly 20 miles long, of very unequal breadth, but at the broadest part about $1\frac{1}{2}$ miles. The scenery of its shores is very beautiful. About 3 miles from the sea, at Connel Ferry, a ridge of sunken rocks crossing it causes a turbulent rapid, which at half-tide forms a sort of waterfall.

Etna, or **ÆTNA, MOUNT**, the greatest volcano in Europe, a mountain in the province of Catania in Sicily; height, 10,874 feet. It rises immediately from the sea, has a circumference of more than 100 miles, and dominates the whole north-east part of Sicily, having a number of towns and villages on its lower slopes. The top is covered with perpetual snow; midway down is the woody or forest region; at the foot is a region of orchards, vineyards, olive groves, &c. Etna thus presents the variety of climates common to high mountains in lower latitudes, oranges and lemons and other fruits growing at the foot, the vine rather higher up, then oaks, chestnuts, beeches, and pines, while on the loftiest or desert region vegetation is of quite a stunted

character. A more or less distinct margin of cliff separates the mountain proper from the surrounding plain; and the whole mass seems formed of a series of superimposed mountains, the terminal volcano being surrounded by a number of cones, all of volcanic origin, and nearly 100 of which are of considerable size. The different aspects of the mountain present an astonishing variety of features—woods, forests, pastures, culti-

vated fields, bare rocky precipices, streams of lava, masses of ashes and scoriæ, as also picturesque towns and villages. From the summit the view presents a splendid panorama, embracing the whole of Sicily, the Lipari Islands, Malta, and Calabria. The eruptions of Etna have been numerous, and many of them destructive. That of 1169 overwhelmed Catania and buried 15,000 persons in the ruins. In 1669 the lava



Mount Etna, as seen from Reggio in Calabria.

spread over the country for forty days, and 10,000 persons are estimated to have perished. In 1693 there was an earthquake during the eruption, when over 60,000 lives were lost. One eruption was in 1755, the year of the Lisbon earthquake. Among more recent eruptions are those of 1832, 1865, 1874, 1879. An eruption is ordinarily preceded by premonitory symptoms of longer or shorter duration. The population of the district of Etna is about 300,000.

E'ton, a town of England, in Buckinghamshire, on the left bank of the Thames, and opposite Windsor, 22 miles west of London. Eton derives its celebrity wholly from its college, one of the great public schools of England, founded by Henry VI. in 1440. The building, which was commenced in 1441 and finished in 1523, has received important additions in recent times in the shape of mathematical and science schools, a mu-

seum, &c. The number of scholars on the foundation is fixed at seventy, but there are about 800 other scholars (mostly the sons of wealthy parents) who are boarded in the houses of the masters. The town is connected with Windsor by a bridge across the river. Pop. 3986.

Etru'ria (Greek, *Tyrrhenia*), the name anciently given to that part of Italy which corresponded partly with the modern Tuscany, and was bounded by the Mediterranean, the Apennines, the river Magra, and the Tiber. The name of Tusci or Etrusci was used by the Romans to designate the race of people anciently inhabiting this country, but the name by which they called themselves was Rasena (or perhaps more correctly Ta-rasena). These Rasena entered Italy at a very early period from the north, and besides occupying Etruria proper, extended their influence to Campania, Elba, and Cor-

sica. Etruria proper was in a flourishing condition before the foundation of Rome, 753 B.C. It was known very early as a confederation of twelve great cities, each of which formed a republic of itself. Amongst the chief were Veii, Clusium, Volsinii, Arretium, Cortona, Falerii, and Faesulae; but the list may have varied at different epochs. The chiefs of these republics were styled *lucumōnes*, and united the office of priest and general. They were elected for life. After a long struggle with Rome the Etruscan power was completely broken by the Romans in a series of victories, from the fall of Veii in 396 B.C. to the battle at the Vadimonian Lake (283 B.C.). The Etruscans had attained a high state of civilization. They carried on a flourishing commerce, and at one time were powerful at sea. They were less warlike than most of the nations around them, and had the custom of hiring mercenaries for their armies. Of the Etruscan language little is known, although more than 3000 inscriptions have been preserved. It was written in characters essentially the same as the ancient Greek; but philologists have not as yet been able to decide with what language it is connected, nor to agree in the decipherment of almost any inscription. The Etruscans were specially distinguished by their religious institutions and ceremonies, which reveal tendencies gloomy and mystical. Their gods were of two orders, the first nameless, mysterious deities, exercising a controlling influence in the background on the lower order of gods, who manage the affairs of the world. At the head of these is a deity resembling the Roman Jupiter (in Etruscan *Tinia*). But it is characteristic of the Etruscan religion that there is also a *Veiovis* or evil Jupiter. The Etruscan name of Venus was *Turan*, of Vulcan *Sethlans*, of Bacchus *Phuphluns*, of Mercury *Turms*. Etruscan art was in the main borrowed from Greece. For articles in terra cotta, a material which they used mainly for ornamental tiles, sarcophagi, and statues, Etruscans were especially celebrated. In the manufacture of pottery they had made great advances; but most of the painted vases popularly known as Etruscan are undoubtedly productions of Greek workmen. (See *Etruscan Vases*.) The skill of the Etruscans in works of metal is attested by ancient writers, and also by numerous extant specimens, such as necklaces, ear-rings, bracelets, &c. The bronze candelabra, of

which many examples have been preserved, were eagerly sought after both in Greece and Rome. A peculiar manufacture was that of engraved bronze mirrors. These were polished on one side, and have on the other an engraved design, taken in most cases from Greek legend or mythology. The Etruscans showed great constructive and engineering skill. They were acquainted with the principle of the arch, and the massive ruins of the walls of their ancient cities still testify to the solidity of their constructions. Various arts and inventions were derived by the Romans from the Etruscans.

Etruria, KINGDOM OF, in Italy, founded by Napoleon I. in 1801. Its capital was Florence. In 1807 Napoleon incorporated it with the French empire.

Etruscan Language. See *Etruria*.

Etruscan Vases, a class of beautiful ancient painted vases made in Etruria, but not strictly speaking a product of Etruscan



Etruscan Vases.

art, since they were really the productions of a ripe age of Greek art, the workmanship, subjects, style, and inscriptions being all Greek. They are elegant in form and enriched with bands of beautiful foliage and other ornaments, figures and similar subjects of a highly artistic character. One class has black figures and ornaments on a red ground—the natural colour of the clay; another has the figures left of the natural colour and the ground painted black. The former class belong to a date about 600 B.C., the latter date about a century later, and extend over a period of about 300 or 350 years, when the manufacture seems to have ceased. During this period there was much variety in the form and ornamentation, gold and other colours besides the primitive ones of black and red being frequently made use of. The subjects represented upon these vases frequently relate to heroic personages of the Greek mythology, but many scenes of an ordinary and even of a domestic character are depicted. The figures are usually

in profile: temples are occasionally introduced; and many curious particulars may be learned from these vase pictures regarding the Hellenic ritual, games, festivities, and domestic life.

Et'tlingen, a town of Baden, 5 miles from Carlsruhe, with manufactures of linen and cotton goods, &c. Pop. 6201.

Et'trick, a district of Scotland, in Selkirk, through which the Ettrick water runs. It is now a sheep-pasture denuded of wood, but anciently formed part of Ettrick Forest, which included the whole county as well as parts of Peebles and Edinburghshire. The *Ettrick Shepherd*, James Hogg, was a native of this district.

Etty, WILLIAM, an English painter, born in 1787, died in 1849. He studied at the Royal Academy. He worked long without much recognition, but at length in 1820 he won public notice by his *Coral Finders*. In 1828 he was elected an academician. Among his works, which were greatly admired, are a series of three pictures (1827-31) illustrating the Deliverance of Bethulia by Judith, Benaiah one of David's mighty men, Woman interceding for the Vanquished. All these are very large pictures, and are now in the National Gallery of Scotland. Others of note are *The Judgment of Paris*, *The Rape of Proserpine*, *Youth at the Prow* and *Pleasure at the Helm*. In colouring and the representation of the nude or partially nude figure, particularly females, he displays high ability.

Etymol'ogy, a term applied (1) to that part of grammar which treats of the various inflections and modifications of words and shows how they are formed from simple roots; (2) to that branch of philology which traces the history of words from their origin to their latest form and meaning. Etymology in this latter sense, or the investigation of the origin and growth of words, is amongst the oldest of studies. Plato and other Greek philosophers, the Alexandrian grammarians, the scholiasts, the Roman Varro, and others wrote much on this subject. But their work is made up of conjectures at best ingenious rather than sound, and very often wild and fantastic. It was not till recent times, and particularly since the study of Sanskrit, that etymology has been scientifically studied. Languages then began to be properly classed in groups and families, and words were studied by a comparison of their growth and relationship in different languages. It was recognized that

the development of language is not an arbitrary or accidental matter, but proceeds according to general laws. The result was a great advance in etymological knowledge and the formation of a new science of philology (which see).

Etzel. See *Attila*.

Eu (*eu*), a town in N. France, dep. Seine-Inférieure, about 17 miles north-east of Dieppe. It is notable for its old church and the celebrated Château d'Eu. Pop. 4436.

Eubœ'a, formerly called Negropont, a Greek island, the second largest island of the Ægean Sea. It is 90 miles in length; 30 in greatest breadth, reduced at one point to 4 miles. It is separated from the mainland of Greece by the narrow channels of Egripo and Talanta. It is connected with the Bœotian shore by a bridge. There are several mountain peaks over 2000 feet, and one over 7000 feet. The island is well-wooded and remarkably fertile. Wine is a staple product, and cotton, wool, pitch, and turpentine are exported. The chief towns are Chalcis and Karysto. The island was anciently divided among seven independent cities, the most important of which were Chalcis and Eretria, and its history is for the most part identical with that of those two cities. With some small islands it forms a modern nomarchy, with a pop. of 95,136.

Eubu'lus, a Greek comic writer, who flourished at Athens about B.C. 375. His subjects were chiefly mythological.

Eucalyp'tus, a genus of trees, nat. order



Blue Gum-tree (*Eucalyptus globulus*)

Myrtaceæ, mostly natives of Australia, and remarkable for their gigantic size, some of

them attaining the height of 480 or 500 feet. In the Australian colonies they are known by the name of gum-trees, from the gum which exudes from their trunks; and some of them have also such names as 'stringy bark,' 'iron bark,' &c. The wood is excellent for ship-building and such purposes. The *E. globulus*, or blue gum, yields an essential oil which is valuable as a febrifuge, antiasthmatic, and antispasmodic; the medicinal properties of this tree also make it useful as a disinfectant, and as an astringent in affections of the respiratory passages, being employed in the form of an infusion, a decoction, or an extract, and cigarettes made of the leaves being also smoked. The *E. globulus* and the *E. amygdalina* are found to have an excellent sanitary effect when planted in malarious districts such as the Roman Campagna, parts of which have already been reclaimed by their use. This result is partly brought about by the drainage of the soil (the trees absorbing great quantities of moisture), partly perhaps by the balsamic odour given out. *E. mannifera* and others yield a sweet secretion resembling manna. Some yield a kind of gum kino. The *Eucalyptus* has been introduced with success into India, Algiers, Southern France, &c.

Eucharist (ū'ka-rist; Greek *eucharistia*, from *eu*, well, and *charis*, grace), a name for the sacrament of the Lord's supper, in reference to the blessing and thanksgiving which accompany it. See *Lord's Supper*.

Euchre (ū'kēr), a game at cards, very popular in America, played mostly by two or four persons. After cutting for the deal, five cards are dealt (either by twos and threes or by threes and twos) to each player. The uppermost card of those undealt is turned for trump. The first player has the option either to 'order up' (*i.e.* to make this card trump) or 'pass.' In the latter case it is left to the next player to decide if he will play first or pass, and so on till the turn of the dealer comes, who must either play on this trump or turn it down, when all the players have again their choice in turn of making a new trump or passing. If a trump is 'ordered up' or taken in the first round, the dealer may take it into his cards, discarding instead his poorest card. If the player who elects to play wins five tricks, he counts two; if he wins three tricks he counts one; if he wins fewer than three tricks he is *cuchred*, and each independent opponent counts two. The cards rank as

at whist, except that the knave of the trump suit, called the *right bower* (from Ger. *bauer*, a peasant), is the highest card, and the knave of the other suit of the same colour the second highest.

Euclid (*Euclidēs*), of Alexandria, a distinguished Greek mathematician, who flourished about 300 B.C. His Elements of Geometry (*Stoicheia*), in thirteen books, are still extant, and form the most usual introduction to the study of geometry. The severity and accuracy of his methods of demonstration have as a whole never been surpassed. Besides the Elements, some other works are attributed to Euclid.

Euclid (*Euclidēs*), of Megara, an ancient Greek philosopher, the founder of the Megaric school of philosophy, and a pupil of Socrates.

Eudiometer (Gr. *eudios*, serene), an instrument originally designed for ascertaining the purity of the air or the quantity of oxygen it contains, but now employed generally in the analysis of gaseous mixtures. It consists of a graduated glass tube, either straight or bent in the shape of the letter **U**, hermetically sealed at one end and open at the other. Two platinum wires, intended for the conveyance of electric sparks through any mixture of gases, are inserted through the glass near the closed end of the tube, and approach but do not touch each other. The electric spark causes chemical combination to take place between the oxygen in the gas to be analysed, and hydrogen which has been introduced into the tube, and the nature and proportion of the constituents of the gaseous mixture are determined by the diminution in volume after the passing of the spark. Or certain substances, such as caustic potash, pyrogallic acid, &c., may be introduced into the closed tube in order to absorb the gases present one by one.

Eugene (ū-jēn'), or FRANÇOIS EUGÈNE, Prince of Savoy, fifth son of Eugène Maurice, duke of Savoy-Carignan, and Olympia Mancini, a niece of Cardinal Mazarin, was born at Paris Oct. 18, 1663. Offended with Louis XIV. he entered the Austrian service in 1683, serving his first campaign as a volunteer against the Turks. Here he distinguished himself so much that he received a regiment of dragoons. Later, at the sieges of Belgrade and Mayence, he increased his reputation, and on the outbreak of war between France and Austria he received the command of the imperial forces sent to Piedmont to act in conjunction with the troops

of the Duke of Savoy. At the end of the war he was sent as commander-in-chief to Hungary, where he defeated the Turks at the battle of Zenta (Sept. 11, 1697). The Spanish war of succession brought Eugene again into the field. In Northern Italy he outmanœuvred Catinat and Villeroy, defeating the latter at Cremona (1702). In 1703 he commanded the imperial army in Germany, and in co-operation with Marlborough frustrated the plans of France and her allies. In the battle of Höchststadt or Blenheim, Eugene and Marlborough defeated the



Prince Eugene.

French and Bavarians under Marshal Tallard, Aug. 13, 1704. Next year Eugene, returning to Italy, forced the French to raise the siege of Turin, and in one month drove them out of Italy. During the following years he fought on the Rhine, took Lille, and, in conjunction with Marlborough, defeated the French at Oudenarde (1708), and Malplaquet (1709), where he himself was dangerously wounded. After the recall of Marlborough, which Eugene opposed in person at London, without success, and the defection of England from the alliance against France, his farther progress was in a great measure checked. In the war with Turkey, in 1716, Eugene defeated two superior armies at Peterwaradin and Temesvar, and, in 1717, took Belgrade, after having gained a decisive victory over a third army that came to its relief. During fifteen years of peace which followed, Eugene served Austria as faithfully in the cabinet as he had done in the field. He died in Vienna April 21, 1736. He was one of the great generals of modern times.

Eugénia (so named in honour of Prince

Eugene), a genus of dicotyledonous polypetalous plants of the natural order Myrtaceæ, nearly related to the myrtle. It contains numerous species, some of which produce delicious fruits. The allspice or pimento is the berry of the *E. Pimenta*. *E. acris* is the wild clove.

Eugenic Acid, or **EUGENOL**, an acid derived from cloves, and conferring on them their essential properties.

Eugénie (eu-zhā-nē), **MARIE DE GUZMAN**, Ex-empress of the French, born at Granada in Spain in 1826. Her father, the Count de Montijo, was of a noble Spanish family; her mother was of Scotch extraction, maiden name Kirkpatrick. On Jan. 29, 1853, she became the wife of Napoleon III. and empress of the French. On March 16, 1856, a son was born of the marriage. When the war broke out with Germany she was appointed regent (July 27, 1870) during the absence of the emperor, but on the 4th Sept. the revolution forced her to flee from France. She went to England, where she was joined by the prince imperial and afterwards by the emperor. Camden House, Chislehurst, became the residence of the imperial exiles. On Jan. 9, 1873, the emperor died, and six years later the prince imperial was slain while with the English army in the Zulu war. In 1881 the empress transferred her residence to Farnborough in Hampshire.

Eugénus, the name of four popes.—1. **EUGENIUS I.**, elected Sept. 8, 654, while his predecessor, Martin I., was still living; died in 657 without having exerted any material influence on his times.—2. **EUGENIUS II.** held the see from 824–827.—3. **EUGENIUS III.**, born at Pisa, was a disciple of St. Bernard of Clairvaux. He was raised to the popedom in 1145, was obliged to quit Rome in 1146 in consequence of the commotions caused by Arnold of Brescia; returned by the help of King Roger of Sicily in 1150, and died in 1153.—4. **EUGENIUS IV.**, from Venice, originally called Gabriel Condolmero, was raised to the popedom in 1431. In consequence of his opposition to the council of Basel he was deposed. He died in 1447.

Eugubine Tables, the name given to seven bronze tablets or tables found in 1444 at the town of Gubbio, the ancient Iguvium or Eugubium, now in the Italian province of Perugia, bearing inscriptions in the language of the ancient Umbrians, which seems to have somewhat resembled the ancient Latin as well as the Oscan. They seem to

have been inscribed three or four centuries B.C., and refer to sacrificial usages and ritual.

Euhem'erism, or EUHEMERISM, a method or system (so named from its founder Euhemerus, a Greek philosopher) of interpreting myths and mythological deities, by which they are regarded as deifications of dead heroes and poetical exaggerations of real histories.

Eulenspiegel (oi'len-spē-gl), TILL, a name which has become associated in Germany with all sorts of wild, whimsical frolics, and with many amusing stories. Some such popular hero of tradition and folk-lore seems to have really existed in Germany, probably in the first half of the 14th century, and a collection of popular tales of a frolicsome character, originally written in Low German, purports to contain his adventures. The earliest edition of such is a Strasburg one of the year 1515 in the British Museum. Better known, however, is that of 1519, published also at Strasburg by Thomas Mürner. The work was early translated into English and almost all European tongues.

Euler (oi'lér or ū'lér), LEONARD, a distinguished mathematician, born at Basel in 1707, and educated at the University of Basel under the Bernouilli, through whose influence he procured a place in the Academy of St. Petersburg. In 1741 he accepted an invitation from Frederick the Great to become professor of mathematics in the Berlin Academy, but in 1766 returned to St. Petersburg, where he died in 1783, in the office of director of the mathematical class of the academy. Euler's profound and inventive mind gave a new form to the science. He applied the analytic method to mechanics and greatly improved the integral and differential calculus. He also wrote on physics, and employed himself in metaphysical and philosophical speculations. Amongst his numerous writings are the *Theoria Motuum Planetarum et Cometarum*; *Introductio in Analysin Infinitorum*; *Opuscula Analytica*; &c.

Eu'menes (-nēz), the name of two kings of Pergamus.—1. EUMENES I. succeeded his uncle Philetærus B.C. 263. He reigned for twenty-two years and then died in a fit of drunkenness.—2. EUMENES II. succeeded his father Attalus B.C. 197, and, like him, attached himself to the Romans, who, as a reward for his services in the war against Antiochus of Syria, bestowed upon him the Thracian Chersonesus and almost all Asia on this side of the Taurus. He died in 159 B.C.

Eumenides (ū-men'dēz). See *Furies*.

Eunomians, the followers of Eunomius, Bishop of Cyzicum, in the 4th century A.D., who held that Christ was a created being of a nature unlike that of the Father.

Eu'nuch, a male of the human species emasculated by castration. The term is of Greek origin (*eunouchos*, from *eunē*, a couch or bed, *echein*, to hold or guard); but eunuchs became known to the Greeks no doubt from the practice among Eastern nations of having them as guardians of their women's apartments. Eunuchs were employed in somewhat similar duties among the Romans in the luxurious times of the empire, and under the Byzantine monarchs they were common. The Mohammedans still have them about their harems. Emasculation, when effected in early life, produces singular changes in males and assimilates them in some respects to women, causing them in particular to have the voice of a female. Hence, not so long ago, it was not uncommon in Italy to castrate boys in order to fit them for soprano singers when grown to manhood.

Euon'ymus, the spindle-tree or prick-wood, a genus of shrubs or trees, nat. order Celastrineæ, containing about fifty species, natives of the temperate regions of the northern hemisphere. See *Spindle-tree*.

Eupata'ria, or EUPATO'RIA, formerly Kosloff, a seaport in Russia, on the western coast of the Crimea, gov. of Taurida. It was here that the allied forces landed at the commencement of the Crimean war (Sept. 14–18, 1854). Pop. 13,416.

Eupato'rium, a genus of plants, chiefly natives of America, belonging to the natural order Compositæ. Their roots are perennial, possessing a rough, bitter, or aromatic taste; the flowers are small, white, reddish, or bluish, in corymbs. Amongst the many species are *E. cannabinum*, or hemp-agrimony, a British plant, and *E. perfoliātum*, thorough-wort or bone-set. See *Bone-set*.

Eupen (oi'pen), a town in Rhenish Prussia, 7 miles s.s.w. of Aix-la-Chapelle. It has manufactures of woollen and linen cloth, hats, soap, leather, and chemicals; paper, flax, and worsted mills; and an important trade. The town was ceded to Prussia at the Peace of Paris in 1814. Pop. 15,441.

Eupho'nium, a brass bass instrument, generally introduced into military bands, and frequently met with in the orchestra as a substitute for the bass trombone, from which, however, it is very different in tone.

It is tuned on C or on B flat, and is furnished with three or four valves or pistons.

Euphorbia'ceæ, the spurge-worts, a natural order of herbaceous plants, shrubs, or very large trees, which occur in all regions of the globe. Most of them have an acrid milky juice, and diclinous or monœcious flowers. The fruit is dry or slightly fleshy, and three-lobed. Among the genera are: *Euphorbia*, which yields an oil used as a powerful cathartic; *Croton*, affording croton-oil; the *Ricinus communis*, or castor-oil plant; the *Buxus sempervirens*, or box-wood plant; the *Jatropha Manihot*, which yields the food known as tapioca or cassava. In most members of the genera the milky juice contains caoutchouc. See *Cassava*, *Castor-oil*, *Croton*, *Manchineel*, *Spurge*.

Euphor'bium, a yellowish-white body, which is the solidified juice of certain plants of the genus *Euphorbia*, either exuding naturally or from incisions made in the bark. It is a powerfully acrid substance, virulently purgative and emetic.

Euphra'sia. See *Eyebright*.

Euphra'tes, or EL FRAT, a celebrated river of Western Asia, in Asiatic Turkey, having a double source in two streams rising in the Anti-Taurus range. Its total length is about 1750 miles, and the area of its basin 260,000 sq. miles. It flows mainly in a south-easterly course through the great alluvial plains of Babylonia and Chaldæa till it falls into the Persian Gulf by several mouths, of which only one in Persian territory is navigable. About 100 miles from its mouth it is joined by the Tigris, when the united streams take the name of Shatt-el-Arab. It is navigable for about 1200 miles, but navigation is somewhat impeded by rapids and shallows. The melting of snow in the Taurus and Anti-Taurus causes a flooding in spring. The water is highest in May and June, when the current, which rarely exceeds 3 miles an hour, rises to 5.

Euphrates Valley Railway, a projected railway from the Levant to India. Projects for shortening the journey to India by the construction of a railway in the Euphrates valley have been repeatedly discussed, and some such expeditious method of reinforcing the British troops in India is highly desirable. At present the schemes spoken of are various, some recommending the Tigris, and some the Euphrates valley. The original project was to connect the Bosphorus with the Persian Gulf. From a strategical point of view it would be impor-

tant for Britain to have at least a branch line commencing opposite Cyprus, where its starting-point would be protected.

Euphrosyne (ū-froz'i-nē; 'Mirth'), one of the three Graces. See *Graces*.

Eu'phuism, an affected style of speech which distinguished the conversation and writings of many of the wits of the court of Queen Elizabeth. The name and the style were derived from the Euphues, the Anatomy of Wit (about 1580), and the Euphues and his England (about 1582), of John Lyly.

Eu'polis, an Athenian comic poet, who flourished about 429 B.C. Neither the date of his birth nor that of his death is known with certainty. He belongs, like Aristophanes and Cratinus, to the Old Comedy. His works are all lost except small fragments.

Eura'sians (syncopated from Europ-Asians), a name sometimes given to the 'half-castes' of India, the offspring of European fathers and Indian mothers. They are particularly common in the three presidential capitals—Calcutta, Madras, and Bombay. They generally receive a European education, and the young men are often engaged in government or mercantile offices. The girls in spite of their dark tint are generally very pretty and often marry Europeans.

Eure (*eur*), a river of N.W. France, which rises in the department of the Orne, and falls into the Seine after a course of 124 miles, being navigable for about half the distance. It gives its name to a department in the N.W. of France, forming part of Normandy; area, 2300 square miles. The surface consists of an extensive plain, intersected by rivers, chief of which is the Seine. Almost the whole surface is profitably occupied, the waste not amounting to one-thirtieth of the whole. Apples, pears, plums, and cherries form important crops, and a little wine is produced. The mining and manufacturing industries are extensive, and the department has a considerable trade in woollen cloth, linen and cotton fabrics, carpets, leather, paper, glass. Evreux is the capital. Pop. 1891, 349,471.

Eure-et-Loir (*eur-è-lwâr*), a department in the N.W. of France, forming part of the old provinces of Orléannais and Ile-de-France; area, 2267 square miles. A ridge of no great height divides the department into a north and a south basin, traversed respectively by the Eure and the Loire. The

soil is extremely fertile, and there is scarcely any waste land. A considerable portion is occupied by orchards and vineyards, but the greater part is devoted to cereal crops. The department is essentially agricultural, and has few manufactures. The capital is Chartres. Pop. 1891, 284,683.

Eure'ka (Gr. *heurēka*, I have found it), the exclamation of Archimedes when, after long study, he discovered a method of detecting the amount of alloy in King Hiero's crown. Hence the word is used as an expression of triumph at a discovery or supposed discovery.

Eurip'ides (-dēz), a celebrated Athenian tragedian, born B.C. 480, or, according to the Arundel marbles, 485, at Salamis. He studied under Prodicus and Anaxagoras, and is said to have begun to write

tragedies at the age of eighteen, although his first published play, the *Peliades*, appeared only in 455 B.C. He was not successful in gaining the first prize till the year 441 B.C., and he continued to exhibit till 408 B.C., when he exhibited the *Orestes*. The violence of unscrupulous enemies, who accused him of impiety and unbelief in the gods, drove Euripides to take refuge at the court of Archelaus, king of Macedonia, where he was held in the highest honour. According to a tradition he was killed by hounds in 406 B.C. Euripides is a master of tragic situations and pathos, and shows much knowledge of human nature and skill in grouping characters, but his works lack the artistic completeness and the sublime earnestness that characterize *Æschylus* and *Sophocles*. Euripides is said to have composed seventy-five, or according to another authority ninety-two tragedies. Of these eighteen (or nineteen, including the *Rhesus*) are extant, viz.: *Alcestis*, *Medea*, *Hippolytus*, *Hecuba*, *Heracleidæ*, *Supplices*, *Ion*, *Hercules Furens*, *Andromache*, *Troades*, *Electra*, *Helena*, *Iphigenia in Tauris*, *Orestes*, *Phœnissæ*, *Bacchæ*, *Iphigenia in Aulis*, and *Cyclops*.

Euripus (ū-rī'pus), in ancient geography,

the strait between the island of Eubœa and Bœotia in Greece.

Euroc'lydon, a tempestuous wind of the Levant, which was the occasion of the shipwreck of the vessel in which St. Paul sailed, as narrated in Acts xxvii. 14-44. The north-east wind is the wind evidently meant in the narrative.

Euro'pa, in Greek mythology, the daughter of Agēnor, king of the Phœnicians, and the sister of Cadmus. The fable relates that she was abducted by Jupiter, who for that occasion had assumed the form of a bull, and swam with his prize to the island of Crete. Here Europa bore to him Minos, Sarpēdon, and Rhadamanthus.

Europe, the smallest of the great continents, but the most important in the history of civilization for the last two thousand years. It forms a huge peninsula projecting from Asia, and is bounded on the N. by the Arctic Ocean; on the W. by the Atlantic Ocean; on the S. by the Mediterranean, the Black Sea, and the Caucasus range; on the east by the Caspian Sea, the Ural River, and the Ural Mountains. The most northerly point on the mainland is Cape Nordkyn, in Lapland, in lat. 71° 6'; the most southerly points are Punta da Tarifa, lat. 36° N., in the Strait of Gibraltar, and Cape Matapan, lat. 36° 17', which terminates Greece. The most westerly point is Cape Roca in Portugal, in lon. 9° 28' W., while Ekaterinburg is in lon. 60° 36' E. From Cape Matapan to North Cape is a direct distance of 2400 miles, from Cape St. Vincent to Ekaterinburg, north-east by east, 3400 miles; area of the continent, about 3,800,000 square miles. Great Britain and Ireland, Iceland, Nova Zembla, Corsica, Sardinia, Sicily, Malta, Crete, the Ionian and the Balearic islands are the chief islands of Europe. The shores are very much indented, giving Europe an immense length of coast-line (estimated at nearly 50,000 miles). The chief seas or arms of the sea are: the White Sea on the north; the North Sea or German Ocean on the west, from which branches off the great gulf or inland sea known as the Baltic; the English Channel, between England and France; the Mediterranean, communicating with the Atlantic by the Strait of Gibraltar (at one point only 19 miles wide); the Adriatic and Archipelago, branching off from the Mediterranean; and the Black Sea, connected with the Archipelago through the Hellespont, Sea of Marmora, and Bosphorus.

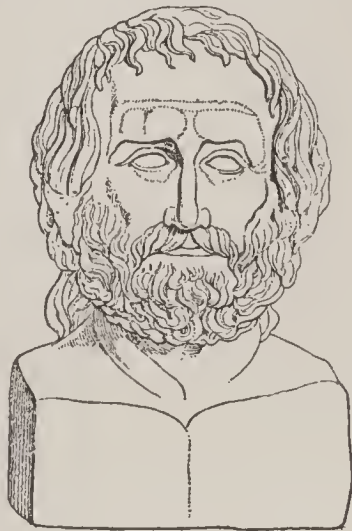

Euripides.

EUROPE.

Surface.—The mountains form several distinct groups or systems of very different geological dates, the loftiest mountain masses being in the south central region. The Scandinavian mountains in the north-west, to which the great northern peninsula owes its form, extend above 900 miles from the Polar Sea to the south point of Norway. The highest summits are about 8000 feet. The Alps, the highest mountains in Europe (unless Mount Elbruz in the Caucasus is claimed as European), extend from the Mediterranean first in a northerly and then in an easterly direction, and attain their greatest elevation in Mont Blanc (15,781 feet), Monte Rosa, and other summits. Branching off from the Alps, though not geologically connected with them, are the Apennines, which run south-east through Italy, constituting the central ridge of the peninsula. The highest summit is Monte Corno (9541 feet). Mount Vesuvius, the celebrated volcano in the south of the peninsula, is quite distinct from the Apennines. By south-eastern extensions the Alps are connected with the Balkan and the Despotodagh of the south-eastern peninsula of Europe. Among the mountains of South-western Europe are several massive chains, the loftiest summits being in the Pyrenees, and in the Sierra Nevada in the south of the Iberian Peninsula. The highest point in the former, La Maladetta or Mont Maudit, has an elevation of 11,165 feet; Mulahacen, in the latter, is 11,703 feet, and capped by perpetual snow. West and north-west of the Alps are the Cevennes, Jura, and Vosges; north and north-east, the Harz, the Thüringerwald Mountains, the Fichtelgebirge, the Erzgebirge and Böhmerwaldgebirge. Further to the east the Carpathian chain incloses the great plain of Hungary, attaining an elevation of 8000 or 8500 feet. The Ural Mountains between Europe and Asia reach the height of 5540 feet. Besides Vesuvius other two volcanoes are Etna in Sicily, and Hecla in Iceland. A great part of northern and eastern Europe is level. The *great plain* of North Europe occupies part of France, Western and Northern Belgium, Holland, the northern provinces of Germany, and the greater part of Russia. A large portion of this plain, extending through Holland and North Germany, is a low sandy level not unfrequently protected from inroads of the sea only by means of strong dykes. The other great plains of Europe are the plain of Lombardy

(the most fertile district in Europe) and the plain of Hungary. Part of Southern and South-eastern Russia consists of steppes.

Rivers and Lakes.—The main European watershed runs in a winding direction from south-west to north-east, at its north-eastern extremity being of very slight elevation. From the Alps descend some of the largest of the European rivers, the Rhine, the Rhone, and the Po, while the Danube, a still greater stream, rises in the Black Forest north of the Alps. The Volga, which enters the Caspian Sea, an inland sheet without outlet, is the longest of European rivers, having a direct length of nearly 1700 miles, including windings 2400 miles. Into the Mediterranean flow the Ebro, the Rhone, and the Po; into the Black Sea, the Danube, Dnieper, Dniester, and Don (through the Sea of Azov); into the Atlantic, the Guadalquivir, the Guadiana, the Tagus, and Loire; into the English Channel, the Seine; into the North Sea, the Rhine, Elbe; into the Baltic, the Oder, the Vistula, and the Duna; into the Arctic Ocean, the Dwina. The lakes of Europe may be divided into two groups, the southern and the northern. The former run along both sides of the Alps, and among them, on the north side, are the lakes of Geneva, Neuchâtel, Thun, Lucerne, Zürich, and Constance; on the south side, Lago Maggiore, and the lakes of Como, Lugano, Iseo, and Garda. The northern lakes extend across Sweden from west to east, and on the east side of the Baltic a number of lakes, stretching in the same direction across Finland on the borders of Russia, mark the continuation of the line of depression. It is in Russia that the largest European lakes are found—Lakes Ladoga and Onega.

Geology.—The geological features of Europe are exceedingly varied. The older formations prevail in the northern part as compared with the southern half and the middle region. North of the latitude of Edinburgh and Moscow there is very little of the surface of more recent origin than the strata of the Upper Jura belonging to the mesozoic period, and there are vast tracts occupied either by eruptive rocks or one or other of the older sedimentary formations. Denmark and the portions of Germany adjoining belong to the Cretaceous period, as does also a large part of Russia between the Volga and the basin of the Dnieper. Middle and Eastern Germany with Poland and the valley of the

EUROPE.

Dnieper present on the surface Eocene formations of the tertiary period. The remainder of Europe is remarkable for the great diversity of its superficial structure, rocks and deposits belonging to all periods being found within it, and having for the most part no great superficial extent. Europe possesses abundant stores of those minerals which are of most importance to man, such as coal and iron, Britain being particularly favoured in this respect. Coal and iron are also obtained in France, Belgium, and Germany. Gold is found to an unimportant extent, and silver is widely spread in small quantities. The richest silver ores are in Norway, Spain, the Erzgebirge, and the Harz Mountains. Spain is also rich in quicksilver. Copper ores are abundant in the Ural Mountains, Thuringia, Cornwall, and Spain. Tin ores are found in Cornwall, the Erzgebirge, and Brittany.

Climate.—Several circumstances concur to give Europe a climate peculiarly genial, such as its position almost wholly within the temperate zone, and the great extent of its maritime boundaries. Much benefit is also derived from the fact that its shores are exposed to the warm marine currents and warm winds from the south-west, which prevent the formation of ice on most of its northern shores. The eastern portion has a less favourable climate than the western. The extremes of temperature are greater, the summer being hotter and the winter colder, while the lines of equal mean temperature decline south as we go east. The same advantages of mild and genial temperature which western has over eastern Europe, the continent collectively has over the rest of the Old World. The diminution of mean temperature, as well as the intensity of the opposite seasons, increases as we go east. Peking, in lat. 40° N., has as severe a winter as St. Petersburg in lat. 60° .

Vegetable Productions.—With respect to the vegetable kingdom Europe may be divided into four zones. The first, or most northern, is that of fir and birch. The birch reaches almost to North Cape; the fir ceases a degree further south. The cultivation of grain extends further north than might be supposed. Barley ripens even under the seventieth parallel of north latitude; wheat ceases at 64° in Norway, 62° in Sweden. Within this zone, the southern limit of which extends from lat. 64° in Norway to lat. 62° in Russia, agriculture has little importance, its inhabitants being chiefly occu-

pled with the care of reindeer or cattle, and in fishing. The next zone, which may be called that of the oak and beech, and cereal produce, extends from the limit above mentioned to the 48th parallel. The Alps, though beyond the limit, by reason of their elevation belong to this zone, in the moister parts of which cattle husbandry has been brought to perfection. Next we find the zone of the chestnut and vine, occupying the space between the 48th parallel and the mountain chains of Southern Europe. Here the oak still flourishes, but the pine species become rarer. Rye, which characterizes the preceding zone on the continent, gives way to wheat, and in the southern portion of it to maize also. The fourth zone, comprehending the southern peninsulas, is that of the olive and evergreen woods. The orange flourishes in the southern portion of it, and rice is cultivated in a few spots in Italy and Spain.

Animals.—As regards animals the reindeer and polar-bears are peculiar to the north. In the forests of Poland and Lithuania the urus, a species of wild ox, is still occasionally met with. Bears and wolves still inhabit the forests and mountains; but, in general, cultivation and population have expelled wild animals. The domesticated animals are nearly the same throughout. The ass and mule lose their size and beauty north of the Pyrenees and Alps. The Mediterranean Sea has many species of fish, but no great fishery; the northern seas, on the other hand, are annually filled with countless shoals of a few species, chiefly the herring, mackerel, cod, and salmon.

Inhabitants.—Europe is occupied by several different peoples or races, in many parts now greatly intermingled. The Celts once possessed the west of Europe from the Alps to the British Islands. But the Celtic nationalities were broken by the wave of Roman conquest, and the succeeding invasions of the Germanic tribes completed their political ruin. At the present day the Celtic language is spoken only in the Scotch Highlands (Gaelic), in some parts of Ireland (Irish), in Wales (Cymric), and in Brittany (Armorican). Next to the Celtic comes the Teutonic race, comprehending the Germanic and Scandinavian branches. The former includes the Germans, the Dutch, and the English. The Scandinavians are divided into Danes, Swedes, and Norwegians. To the east, in general, of the Teutonic race, though sometimes mixed with it, come the

EUROPE.

Slavonians, that is, the Russians, the Poles, the Czechs or Bohemians, the Servians, Croatians, &c. In the south and south-east of Europe are the Greek and Latin peoples, the latter comprising the Italians, French, Spanish, and Portuguese. All the above peoples are regarded as belonging to the Indo-European or Aryan stock. To the Mongolian stock belong the Turks, Finns, Lapps, and Magyars or Hungarians, all immigrants into Europe in comparatively recent times. The Basques at the western extremity of the Pyrenees are a people whose affinities have not yet been determined. The total population of Europe is about 330,000,000; nine-tenths speak the languages of the Indo-European family,

the Teutonic group numbering about 108,000,000, the Slavonic and Latin over 95,000,000 each. The prevailing religion is the Christian, embracing the Roman Catholic Church, which is the most numerous, the various sects of Protestants (Lutheran, Calvinistic, Anglican, Baptists, Methodists, &c.), and the Greek Church. A part of the inhabitants profess the Jewish, a part the Mohammedan religion.

Political Divisions.—The states of Europe, with their respective areas and populations, are as shown below. In addition to those given in the table, there are also the insignificant states of Andorra, Monaco, and San Marino, which still maintain a kind of precarious independence.

STATES.	Area in Eng. sq. miles.	Population.	Designation.
Austria-Hungary,	240,942	40,464,808	Empire.
Liechtenstein,	62	9,124	Principality.
Bosnia, Herzegovina, &c., ...	23,262	1,504,031	Occupied by Austria.
Belgium,	11,373	6,030,043	Kingdom.
Denmark,	14,789	2,108,000	Kingdom.
Faroe and Iceland,	40,266	83,665	
France,	204,090	38,218,903	Republic.
Germany,	211,149	49,922,928	Empire.
Britain,	120,832	38,165,526	Kingdom.
European possessions,	145	175,186	
Greece,	25,014	2,187,208	Kingdom.
Netherlands,	12,648	4,505,932	Kingdom.
Luxemburg,	999	213,283	Grand-duchy.
Italy,	114,410	30,565,253	Kingdom.
Montenegro,	3,658	236,000	Principality.
Portugal,	36,028	4,708,178	Kingdom.
Roumania,	48,307	5,500,000	Kingdom.
Russia,	2,095,504	113,364,649	Empire.
Servia,	18,800	2,013,691	Kingdom.
Spain,	191,100	16,945,786	Kingdom.
Sweden and Norway—			Kingdom.
Sweden,	170,979	4,748,257	
Norway,	122,869	1,959,000	
Switzerland,	15,992	2,933,334	Confederative Republic.
Turkey,	63,850	6,817,265	Empire.
Bulgaria,	24,659	2,007,919	Principality.
Eastern Roumelia,	13,500	975,000	Joined to Bulgaria.

History.—Europe was probably first peopled from Asia, but at what date we know not. The first authentic history begins in Greece at about 776 B.C. Greek civilization was at its most flourishing period about 430 B.C. After Greece came Rome, which, by the early part of the Christian era, had conquered Spain, Greece, Gaul, Helvetia, Germany between the Danube and the Alps, Illyria, Dacia, &c. Improved laws and superior arts of life spread with the Roman empire throughout Europe, and the unity of government was also extremely favourable to the extension of Christianity. With

the decline of the Roman Empire a great change in the political constitution of Europe was produced by the universal migration of the northern nations. The Ostrogoths and Lombards settled in Italy, the Franks in France, the Visigoths in Spain, and the Anglo-Saxons in South Britain, reducing the inhabitants to subjection, or becoming incorporated with them. Under Charlemagne (771–814) a Great Germanic empire was established, so extensive that the kingdoms of France, Germany, Italy, Burgundy, Lorraine, and Navarre were afterwards formed out of it. About this time the northern and

eastern nations of Europe began to exert an influence in the affairs of Europe. The Slaves, or Slavonians, founded kingdoms in Bohemia, Poland, Russia, and the north of Germany; the Magyars appeared in Hungary, and the Normans agitated all Europe, founding kingdoms and principalities in England, France, Sicily, and the East. The Crusades and the growth of the Ottoman power are amongst the principal events which influenced Europe from the 12th to 15th century. The conquest of Constantinople by the Turks (1453), by driving the learned Greeks from this city, gave a new impulse to letters in Western Europe, which was carried onwards by the invention of printing, and the Reformation. The discovery of America was followed by the temporary preponderance of Spain in Europe, and next of France. Subsequently Prussia and Russia gradually increased in territory and strength. The French revolution (1789) and the Napoleonic wars had a profound effect on Europe, the dissolution of the old German Empire being one of the results. Since then the most important events in European history have been the establishment of the independence of Greece; the disappearance of Poland as a separate state; the unification of Italy under Victor Emmanuel; the Franco-German war, resulting in the consolidation of Germany into an empire under the leadership of Prussia; and the partial dismemberment of the Turkish Empire.

Euro'tas, a river of ancient Sparta (in the Morea), called the *Basilipotāmo*.

Eury'ale, a genus of plants of the water-lily order, growing in India and China, where the flouy seeds of some species are used as food.

Eurydice (ū-rid'i-sē), in Greek mythology, the wife of Orpheus. See *Orpheus*.

Euse'bius, the father of ecclesiastical history, a Greek writer, born in Palestine about 265 A.D., died about 340. About 315 he was appointed Bishop of Cæsarea. He became an advocate of the Arians and condemned the doctrines of Athanasius. His ecclesiastical history extends from the birth of Christ to 324. Amongst his other extant works is a life of Constantine the Great.

Eustachian Tube, in anatomy, a canal leading from the pharynx to the tympanum of the ear. See *Ear*, and also next article.

Eustachio, BARTOLOMEO, Italian physician and anatomist, born soon after 1500, died about 1574. He devoted himself to medical science and in particular to anatomy,

which he much enriched by his researches. Amongst his discoveries were the *eustachian tube* (see above art.) and the eustachian valve of the heart.

Eustatius, ST., a Dutch island in the W. Indies, one of the Leeward Islands, 11 miles north-west of St. Christopher's, pyramidal in form; area 8 sq. miles. Sugar, cotton, and maize are raised; but the principal production is tobacco. The climate is healthy, but earthquakes are frequent. Pop. 2335.

Euter'pe (1), one of the Muses, considered as presiding over lyric poetry, the invention of the flute being ascribed to her. She is usually represented as a virgin crowned with flowers, having a flute in her hand. (2) In botany, a genus of palms, natives of South America, sometimes nearly 100 feet in height. See *Assai-palm*.

Eutro'pius, FLAVIUS, a Latin historian, who flourished about 360 A.D. His abridgment of the history of Rome (*Breviarium Historiæ Romanæ*) is written in a perspicuous style.

Eutyches (ū'ti-kēz), a Greek heresiarch who lived in the 5th century after Christ. He was superior of a monastery near Constantinople, and his heresy consisted in maintaining that after the incarnation there was only a divine nature in Christ under the appearance of a human body. The doctrines of Eutyches were condemned by the Council of Chalcedon in 451, and he was expelled from his monastery. He died not long afterwards. His followers were often called Monophysites (Gr. *monos*, single, *physis*, nature) as well as Eutyichians.

Euxanthine, a substance supposed to be derived from the bile or urine of the buffalo, camel, or elephant. It comes from India under the name of purree or Indian yellow, and is used as a pigment.

Eux'ine (*Pontus Euxīnus*), the ancient name for the Black Sea.

Evangel'ical, a term often used to qualify certain theological views, especially strict views on the question of the atonement, justification by faith, the inspiration and authority of the Scriptures, and allied doctrines. In England the so-called Low Church party is evangelical in its views. In a more general sense the word implies a peculiar fervency and earnestness in insisting on such doctrines as regeneration, redemption, &c. The 'Evangelical Church' is the official title of the Established Church of Prussia, formed in 1817 by the union of Lutherans and Calvinists.

Evangelical Alliance, an association of members of different sections of the Christian church, organized in London in 1846, to lend its influence in favour of evangelical doctrines (see above art.), religious union and liberty, and against superstition and unbelief. The alliance has branches throughout the world, the American branch being especially strong, and has held meetings at Paris, Berlin, Amsterdam, Geneva, New York, &c. A week of united prayer is held in London in the early part of January each year.

Evangelical Association, a body of American Christians, chiefly of German descent, established about the beginning of the century. In form of government and mode of worship it generally agrees with the Methodist Episcopal Church.

Evangelical Union, the name of a religious sect, also familiarly known as the Morisonians, from the Rev. James Morison, its originator. It took rise in Scotland in 1840, and three years afterwards organized itself as a separate Christian denomination. The Morisonians maintain the universality of the atonement, combining with this the doctrine of eternal personal and unconditional election, and denying that any one will be condemned for Adam's fall. In point of church government the members of the Evangelical Union are independent. The body has about ninety congregations, chiefly in Scotland.

Evan'gelists, the writers of the history or doctrines, precepts, actions, life, and death of Christ; in particular, the *four evangelists*, Matthew, Mark, Luke, and John. The ancient symbols of the four evangelists are: for Matthew, *a man's face*; for Mark, *a lion*; for Luke, *an ox*; and for John, *a flying eagle*.

Evans, MARIAN. See *Eliot, George*.

Ev'ans, OLIVER, born at Newport, Del., U.S., in 1755, was the inventor of the automatic flour-mill and the high-pressure steam-engine. He died in New York, 21st April, 1819.

Evans, SIR DE LACY, a British general, born at Moig in Ireland in 1787. After some years of service in India he joined the army of Wellington in the Peninsula in 1812, where he served with distinction. In 1814 he was sent to America, and was present at the battles of Bladensburg and New Orleans, returning to Europe in time to take part in Waterloo. In 1830 and 1831 he was elected member for Rye, and in 1833 for

Westminster. In 1835 he was appointed to the command of 10,000 troops raised in Britain on behalf of the Queen of Spain. Under the training of Evans this force became an excellent army, and several times defeated the Carlists. During the Crimean war he distinguished himself as commander of the second division of the English army, and received the thanks of the House and other honours. He died Jan. 9, 1870.

Ev'anston, a town in Illinois, on Lake Michigan, 12 miles N. of Chicago. It is pleasantly situated; has a university with museum and extensive library. Pop. 3900.

Ev'ansville, a city in the United States, in Indiana, pleasantly situated on a height above the Ohio. It contains some handsome buildings, including custom-house and post-office, &c. Coal and iron abound in the vicinity, and there are numerous factories, flour-mills, iron-foundries, &c., and a large shipping trade. Pop. 50,756.

Evaporation, the conversion of a liquid or solid by heat into vapour or steam, which becomes dissipated in the atmosphere in the manner of an elastic fluid. The process of evaporation is constantly going on at the surface of the earth, but principally at the surface of the sea, of lakes, rivers, and pools. The vapour thus formed, being specifically lighter than atmospheric air, rises to considerable heights above the earth's surface; and afterwards, by a partial condensation, forms clouds, and finally descends in rain.

Evarts, WM. M., was born in Boston, Feb. 6, 1818. In 1868 was counsel for Pres. Johnson in the impeachment trial. In 1872 was counsel for the U. S. in the Alabama claims. His fees have amounted to \$50,000 for a single opinion. He was Secretary of State under President Hayes. He was U. S. Senator from 1885 to 1891.

Ev'elyn, JOHN, an English writer of the 17th century, born at Wotton, in Surrey, October 31, 1620; died there, February 27, 1706. After completing his course at Oxford he studied law at the Middle Temple, visited various parts of the Continent, and in 1659 took the royal side in the civil war. He published numerous works, amongst which are *Sculptura*, or the History and Art of Chalcography; *Sylva*, or a Discourse of Forest Trees; treatises on gardening, architecture, &c. But by far his most important work is his memoirs, comprehending a diary and correspondence, which are interesting contributions to the history of the time.

Evening-primrose, *Enothëra*, a genus of plants, nat. order Onagraceæ. *Æ. biennis*, an American species common in cottage gardens, is not unfrequent as an escaped plant in England.

Evening-schools, schools originally established in Britain for the instruction of those whose education has been neglected. They were strongly recommended by the Committee of the Privy-council of Education in 1861. In many cases they have been founded and maintained by private benevolence. A further development of this idea has been the establishment of evening schools or classes for imparting technical instruction to artisans, or for simply carrying farther the instruction begun in the elementary schools. In the larger cities of Great Britain and the United States such institutions have been very successful.

Evening-star, or HESPERUS, the name given to the planet Venus when visible in the evening. See *Venus*.

Ev'ere'tt, ALEXANDER HILL, an American diplomatist, born at Boston in 1792; died at Canton in 1847. After studying at Harvard, in 1809 he accompanied John Quincy Adams to St. Petersburg as secretary of legation. He afterwards filled successive diplomatic posts in the Netherlands, Spain, and elsewhere. He is the author, amongst other works, of *Europe, or a General Survey of the Present Situation of the Principal Powers* (1822); and a similar work on America.

Everett, EDWARD, an American statesman and author, brother of the preceding, born at Dorchester, Massachusetts, April 11, 1794. After travelling for some years in Germany and England he returned to America in 1819 to occupy the chair of Greek Literature at Harvard. He became editor of the *North American Review*, and entering the political world became successively member of Congress, governor of Massachusetts, and minister plenipotentiary in England (1840). In 1845 he was appointed president of Harvard College, and in 1852 secretary of state. Shortly after he retired into private life. He died at Boston, Jan. 15, 1865.

Everett, Middlesex co., Mass. Pop. 11,068.

Everglades, a low marshy tract of country in Southern Florida, inundated with water and interspersed with patches or portions covered with high grass and trees. They are 160 miles long and 60 broad.

Evergreen, a plant that retains its verdure

through all the seasons, as the fir, the holly, the laurel, the cedar, the cypress, the juniper, the holm-oak, and many others. Evergreens shed their old leaves in the spring or summer, after the new foliage has been formed, and consequently are verdant through all the winter season. They form a considerable part of the shrubs commonly cultivated in gardens, and are beautiful at all seasons of the year.

Everlasting-flowers, a name applied to certain plants which, when dried, suffer little change in their appearance. The plants to which this name is peculiarly applied belong to the genus *Helichrysum*, but it is also given to members of allied genera, such as *Antennaria*, *Gnaphalium*, &c.

Everlasting-pea, a popular name for *Lathyrus latifolius*, cultivated in flower-gardens, and belonging to the same genus as the sweet-pea.

Eversion of the Eyelids, ectropium, a disease in which the eyelids are turned outward, so as to expose the red internal tunic. It occurs most frequently in the lower eyelid.

Evesham (ēvz'am), a town in England, in the county and 15 miles S.E. of Worcester, beautifully situated on the Avon, and giving name to a parl. div. of the county. It was the seat of a monastery as early as the 8th century. Pop. 5112.

Eviction, the dispossession of a person from the occupancy of lands or tenements. The term occurs most commonly in connection with the proceedings by which a landlord ejects his tenant for non-payment of rent or on determination of the tenancy. In the case of evictions of tenants in Ireland, generally for non-payment of rent, the tenants are frequently readmitted as caretakers, or under some other title.

Evidence is that which makes evident, which enables the mind to see truth. It may be (a) *intuitive*, i.e. resting on the direct testimony of consciousness, of perception or memory, or on fundamental principles of the human intellect; or it may be (b) *demonstrative*, i.e. in a strict sense, proofs which establish with certainty as in mathematical science certain conclusions; or it may be (c) *probable*, under which class are ranked *moral evidence*, *legal evidence*, and generally every kind of evidence which, though it may be sufficient to satisfy the mind, is not an absolutely certain and incontrovertible demonstration.

In jurisprudence evidence is classified into that which is *direct* and *positive* and that

which is *presumptive* and *circumstantial*. The former is that which is proved by some writing containing a positive statement of the facts and binding the party whom it affects; or that which is proved by some witness, who has, and avers himself to have, positive knowledge thereof by means of his senses. Whenever the fact is not so directly and positively established, but is deduced from other facts in evidence, it is *presumptive* and *circumstantial* only. The following are the leading rules regarding evidence in a court of law:—

(1) The point in issue is to be proved by the party who asserts the affirmative. But where one person charges another with a culpable omission this rule will not apply, the person who makes the charge being bound to prove it. (2) The best evidence must be given of which the nature of the thing is capable. (3) Hearsay evidence of a fact is not admissible. The principal exceptions to this rule are—death-bed declarations, evidence in questions of pedigree, public right, custom boundaries, declarations against interest, declarations which accompany the facts or are part of the *res gesta*, &c. (4) Insane persons and idiots are incompetent to be witnesses. But persons temporarily insane are in their lucid intervals received as witnesses. Children are admissible as witnesses as soon as they have a competent share of understanding and know and feel the nature of an oath and of the obligation to speak the truth.

Evidences of Christianity. These may be divided broadly into two great classes, viz. *external evidences*, or the body of historical testimonies to the Christian revelation; and *internal evidences*, or arguments drawn from the nature of Christianity itself as exhibited in its teachings and effects, in favour of its divine origin. The first Christian apologies—those of Justin Martyr, Minucius Felix, and Tertullian, written in the 2d century—were mainly intended as justifications of the Christian religion against the charges of atheism, immorality, &c., commonly made at that time. Of a more philosophical kind and dealing more comprehensively with the principles of religion and belief in general, are the works of Origen, Arnobius, and Augustine in the centuries immediately succeeding. During the middle ages, the scientific representation of Christianity is mostly the work of the schoolmen occupied in welding Aristotelian or Platonic philosophy with the fabric of Christian dogmatics, or

writing attacks on the Jewish and Mahomedan faiths.

In the 16th and 17th centuries the influences of the Renaissance and the Reformation gave rise to a spirit of inquiry and criticism which developed English deism as represented by Herbert and Hobbes in the 17th century, and Collins and Bolingbroke in the 18th. The general position of English deism was the acceptance of the belief in the existence of God, and the profession of natural religion along with opposition to the mysteries and special claims of Christianity. It was in confutation of this position that the great English works on the evidences of Christianity of Butler, Berkeley, and Cudworth were written. In France the new spirit of inquiry was represented by Diderot, D'Holbach, and the encyclopedists in general, who assailed Christianity mainly on the ground that it was founded on imposture and superstition, and maintained by sacerdotal trickery and hypocrisy. No reply of any great value was produced in the French church, although in the previous age Pascal in his *Pensées* had brought together some of the profoundest considerations yet offered in favour of revealed religion. The 19th century has been distinguished by the strongly rationalistic spirit of its criticism. The works of such writers as Strauss, Bauer, and Feuerbach, attempting to eliminate the supernatural and the mysterious in the origin of Christianity, have been answered by the works of Neander, Ebrard, and Ullmann on the other side. The historical method of investigation, represented alike by the Hegelian school and the Positivists in philosophy, and by the Evolutionists in science, is the basis of the chief attacks of the present time against the supernatural character of Christianity, the tendency of all being to hold that while Christianity is the highest and most perfect development to which the religious spirit has yet attained, it differs simply in degree of development from any other religion. Notable amongst later apologists of Christianity have been Paley (*Natural Theology*), Chalmers (*Natural Theology*), Mansel, Liddon, and others, Lecturers of the Bampton Foundation; in Germany, Luthardt, Ewald, Baumstark, &c.

Evil, ORIGIN OF, the subject of an appalling quantity of barren speculation. The difficulty of the question lies mainly in this, that the existence of evil in the world seems inconsistent with the view that it was cre-

ated and is maintained by an omnipotent and beneficent creator. The various theories on the subject have all sought to elude this difficulty either by the supposition of some principle of evil equally eternal with that of good, or by regarding evil as having only a relative existence, being a kind of good in an imperfect and immature stage. Perhaps the oldest theory upon this subject is that of Parseeism, or the religion of Zoroaster, according to which there were two original principles, one good (Ormuzd) and the other evil (Ahriman). This is the doctrine that is now very often spoken of as Manichæism, from the fact that it was adopted by Manes, who attempted to engraft it on the doctrines of Christianity. In contradistinction to this dualistic theory with reference to the origin of evil stand the Monistic theories of Brahmanism and Platonism. According to the Brahmanic doctrine of the emanation of all things from one original being (Brahma), this original being was regarded as the sole true existence, and the phenomenal world, with all the evils appearing in it, was held to be mere illusion. Similarly Plato held that the good was the essence of all things, and that the evil and imperfect contained in them had no real existence. The theory enunciated by Leibnitz in his *Theodicée* resembles that of Plato. In that work he assigns to the evil existing in the world created by God, which he holds to be the best of all possible worlds, a merely relative existence; all that we call evil, is, he holds, only evil to us because we do not see it in relation to the rest of the universe, for in relation to the universe it is not evil but good, and accordingly cannot be evil in its own nature. Another view on the subject is that which neither assigns to the evil principle (as it does to God or the good principle) an original existence, nor denies the real existence of evil, but ascribes it to the exercise of man's free-will.

Evil Eye, a power which, according to an old and wide-spread superstition, resides in some people of doing injury to others by a mere look, or a look accompanied by certain words or charms. This belief, common amongst the ancients, is still prevalent among the more ignorant classes in Italy, Russia, Andalusia, Turkey, Egypt, the Highlands of Scotland, and other places.

Ev'olute, in geometry, a curve from which another curve, called the *involute* or *evolvent*, is described by the end of a thread

gradually wound upon the former, or unwound from it.

Evolution, literally the act of unrolling or unfolding, but used as a term in science and philosophy to indicate the development of an organism or organic entity towards greater differentiation of organs and functions, and, therefore, to a more complex and higher state of being. Thus, in astronomy, the nebular hypothesis, which regards the planetary bodies as evolved from nebular or gaseous matter, is an example of evolution. In geology, also, the old view which considered the animal and vegetable life of each geological period as a new and separate organic creation, has given place to the evolutionary theory of a process of development from earlier types to those of the later periods. But the evolution of the more complex from the more simple organisms does not necessarily, probably never does, exhibit a linear series of advances: thus of the protoplasm which represents the first stage of an animal's existence, part is set aside for one tissue, part for another; in the same way, on the theory of the origin of certain animal or vegetable forms from a common stock, some members of a group have manifested such modifications as render them permanently unlike their kindred of whom some may retain for a longer or shorter time their original characters, while others become specialized in other directions. Evolution is a law whose operation is traceable throughout every department of nature. It may be equally well illustrated from the history of philosophy or the arts, or from the historical development of society. But it is in connection with the evolutionary theory of the origin of species that the principle of evolution has been most discussed, affirming, as it does, that all forms of life both in the animal and vegetable kingdom have been developed by continuous differentiation of organs and modifications of parts from one low form of life consisting of a minute cell. The steps by which this process has been accomplished and the causes which have been mainly at work in it form a department of research to which many notable scientists—Lamarck, St. Hilaire, Meckel, Hæckel, Spencer, Darwin, Wallace, and others have contributed. One of the greatest contributions to the theory has been the work of Mr. Darwin (*On the Origin of Species*), in which he has produced some of the strongest evidence in favour of evolution as an endless progression evolving higher

species, genera, families, orders, classes, the infinitely varied forms being each adapted to the circumstances by which it is surrounded. See also *Natural Selection, Species*.

Evolution, in mathematics, the process of extracting the roots of numbers or quantities.

Evolvent, in mathematics. See *Evolute*.

Ev'ora, a town in Portugal, capital of the province of Alemtejo, 80 miles east of Lisbon. It is an ancient place, poorly built, and its walls, citadel, and forts are all in a ruinous state. It has a Roman aqueduct still serviceable, a Gothic cathedral, an ecclesiastical seminary, &c. Pop. 13,046.

Evremont, or EVREMONT. See *St. Evremont*.

Evreux (ev-reu), a town of N.W. France, capital of the department of Eure, in a fertile valley on the Iton. Although an ancient town with narrow streets, it is well built, has an ancient Gothic cathedral, a town-house, two theological seminaries. Pop. 9851.

Ewald (ā'vält), GEORG HEINRICH AUGUST VON, a German Orientalist and Biblical critic, born at Göttingen 16th Nov. 1803. After studying at the University there, in 1827 he became extraordinary, in 1831 ordinary professor of theology, and in 1835 professor of Oriental languages. In 1837 he lost his chair at Göttingen on account of his protest against the king's abrogation of the liberal constitution, became professor of theology at Tübingen, but in 1848 returned to his old chair at Göttingen. When Hanover was annexed by Prussia in 1866 he became a zealous defender of the rights of the ex-king. He died at Göttingen 5th May, 1875. Among his chief works are the following: Complete Course of the Hebrew Language; The Poetical Books of the Old Testament; History of the People of Israel; Antiquities of the People of Israel. The History is considered his greatest work.

Ewald (ā'vält), JOHANNES, Danish poet, born at Copenhagen in 1743. After studying theology at Copenhagen University he ran away and enlisted in the Prussian service, which he soon deserted for the Austrian. Having returned to Copenhagen an elegy which he wrote on the death of Frederick V. of Denmark was received with general admiration, and awoke in himself the consciousness of poetic talent. His reputation rapidly increased with the publication of his tragedies, The Death of Balder, Adam and Eve, Rolfkrage, &c.; and his odes and songs.

Ewing, THOS., statesman, was born in

Ohio co., Va., Dec. 28, 1789. In 1831 and 1850 was elected to the U. S. Senate. In 1841 appointed Secretary of the Treasury. In 1849 was made the first Secretary of the Interior. In the U. S. Supreme Court ranked among the foremost lawyers of the nation. He died Oct. 26, 1871.

Exarchate (egz-är'kāt), a name of a province or territory under an *exarch*, or viceroy. In the 6th century after Christ Justinian formed the middle part of Italy into a province of the Eastern Empire, and gave the government of it to an officer called an *exarch*. Exarch was also the title of an ecclesiastical grade in the Greek Church inferior to the patriarchs, but superior to the metropolitans. Among the modern Greeks an *exarch* is a deputy of the patriarch, who travels about in the provinces, and visits the bishops and churches.

Excam'bion, in Scots law, the name given to the contract by which one piece of land is exchanged for another.

Ex'cellency, a title given to ambassadors and plenipotentiaries, governors of colonies, the president of the U. States, &c.

Exchange, a place in large commercial towns where merchants, agents, bankers, brokers, and others concerned in commercial affairs meet at certain times for the transaction of business. The institution of exchanges dates from the 16th century. They originated in the important trading cities of Italy, Germany, and the Netherlands, from which last-named country they were introduced into England. In some exchanges only a special class of business is transacted. Thus there are stock exchanges, corn exchanges, coal exchanges, cotton exchanges, &c. See *Stock Exchange*.

Exchange, in commerce, that species of transactions by which the debts of individuals residing at a distance are cancelled by order, draft, or bill of exchange, without the transmission of specie. Thus, a merchant in London who owes £100 worth of cotton goods in Glasgow, gives a bill or order for that amount which can be negotiated through banking agencies or otherwise against similar debts owing by other parties in Glasgow who have payments to make in London. The creditor in Glasgow is thus paid by the debtor in Glasgow, and this contrivance obviates the expense and risk of transmitting money. The process of liquidating obligations between different nations is carried on in the same way by an exchange of foreign bills. When all the accounts of one

country correspond in value with those of another, so that there is an even balance, the exchange between the countries will be *at par*, that is, the sum for which the bill is drawn in the one country will be the exact value of it in the other. Exchange is said to be *at par* when, for instance, a bill drawn in New York for the payment of £100 sterling in London can be purchased there for £100. If it can be purchased for less, exchange is *under par* and is against London. If the purchaser is obliged to give more, exchange is *above par* and in favour of London. Although the thousand circumstances which incessantly affect the state of debt and credit prevent the ordinary course of exchange from being almost ever precisely at par, its fluctuations are confined within narrow limits, and if direct exchange is unfavourable between two countries this can often be obviated by the interposition of bills drawn on other countries where an opposite state of matters prevails. See also *Bill of Exchange*.

Exchange, DEED OF, in English law, an original common law conveyance for the mutual transfer of real estate. It takes place between two contracting parties only, although several individuals may be included in each party; and the parties must take an equal estate, as fee-simple for fee-simple, legal estate for legal estate, copyhold for copyhold of the same manor, and the like.

Exchequer, in Britain, the department which deals with the moneys received and paid on behalf of the public services of the country. The public revenues are paid into the Bank of England (or of Ireland) to account of the exchequer, and these receipts as well as the necessary payments for the public service are under the supervision of an important official called the Controller and Auditor General, the payments being granted by him on receipt of the proper orders proceeding through the treasury. The public accounts are also audited in his department.

Exchequer, CHANCELLOR OF THE. See *Chancellor*.

Exchequer, COURT OF, an ancient English court of record, established by William the Conqueror, and intended principally for the care and collection of the royal revenues. It was one of the supreme courts of common law, and is said to derive its name from the chequered cloth, resembling a chess-board, on which the sums were marked and scored with counters. The judges of this court

were the chief baron and five junior or *puisné* barons. This court has been merged in the High Court of Justice. In Canada there is a Court of Exchequer for the Dominion.

Exchequer and Audit Department, a department of the English Civil Service charged with the functions of auditing the accounts of all other departments. See *Exchequer*.

Exchequer Bills, bills of credit issued by authority of parliament as a means of raising money for temporary purposes. They are of various sums—£100 or any multiple of £100—and bear interest (generally from $1\frac{1}{2}d.$ to $2\frac{1}{2}d.$ *per diem* on £100) according to a rate fixed at the beginning of each year. These bills pass from hand to hand as money, and form a principal part of the public unfunded debt of Great Britain. *Exchequer bonds* are similar, but they run for a definite number of years at a fixed rate of interest.

Excise, an inland duty or impost laid on commodities produced and consumed within a country, and also on licenses to manufacture and deal in certain commodities. Excise duties were introduced into England by the Long Parliament in 1643, being then laid on the makers and vendors of ale, beer, cider, and perry. Being found to be a convenient and productive source of revenue, they continued to gain ground, and at the present time furnish about two-sevenths of the entire public revenue (or some £26,000,000). In Britain the excise include duties on spirits and beer, licenses on dogs, guns, carriages, servants, plate, railways, game, &c. Spirits and beer yield over £20,000,000.

Excito-motor action, the action of nerves distributed to muscular organs the stimulation of which leads to movement. Thus, irritation of a nerve supplying a muscle will lead to contraction of the muscle by excito-motor action, and irritation of certain nerves distributed to blood-vessels will lead to contraction of the vessel by acting on its muscular coat.

Exclusion, BILL OF, a bill introduced into the British Parliament during the reign of Charles II. for the purpose of excluding the Duke of York (afterwards James II.), he being a R. Catholic, from the throne.

Excommunication, the exclusion of a Christian from the communion and spiritual privileges of the church. Excommunication was practised early by the Christian church. A distinction gradually arose between a lesser and a greater excommunica-

tion, the former being a suspension from church privileges, the latter a formal expulsion excluding from all communion with the faithful. In the middle ages the popes often excommunicated whole cities and kingdoms. In such a case all religious services ceased and the grave inconveniences thus caused made excommunication a formidable weapon in the hands of the pope, till with frequent abuse it lost its force. Besides excommunication an extreme degree of denunciation called *anathema*, and cutting the offender off from all the hopes and consolations of the Christian faith, is used in the Roman Catholic Church. In the Church of England both the less and the greater excommunication are recognized.

Excre'tion, in physiology, the separation and carrying off of waste matter from an animal body, a function performed by the lungs, kidneys, bladder, and the skin, besides the action of the intestinal canal.

Excubito'rium, in mediæval churches, a gallery where public watch was kept at night on the eve of some festival, and from which the great shrines could be seen.

Exe, a river of England, which rises in Exmoor, in the county of Somerset, and after a southerly course of about 50 miles falls into the English Channel at Exmouth.

Execution, in law, is a judicial writ grounded on a judgment of the court by which the writ is issued, and is granted for the purpose of carrying the judgment into effect, by having it executed. Execution is granted by a court only upon the judgments given by the same court, not upon those pronounced by another.

Execution, the carrying out of the punishment of death. See *Capital Punishment*.

Executioner, the official who carries into effect a sentence of death, or inflicts capital punishment in pursuance of a legal warrant. In England the duty of executing the extreme sentence of the law devolves upon the sheriff, and in Scotland on the civic magistracy, but in practice the duty is performed by another in their presence. In the U. S. the duty devolves upon the sheriff.

Exec'utive, that branch of the government of a country by which the laws are carried into effect or the enforcement of them superintended. The term is used in distinction from the *legislative* and the *judicial* departments, and includes the supreme magistrate, whether emperor, king, president, or governor, his cabinet or ministers, and a host of minor officials.

Exec'utor, in law, is one appointed by a man's last will to carry its provisions into execution after the testator's death. The testator may, by the common law, appoint any person of sound mind and discretion, though otherwise under some legal disabilities as to contracting and transacting business in general, such as a married woman, or a minor. The duties of executors and of administrators are, in general, the same, the difference of the two depending mostly on the mode of appointment, the executor being nominated by the testator, the administrator being appointed by the judge of probate. An executor is liable for any loss occurring to the estate through negligence; for paying legatees before all debts are discharged.

Exegesis (-jē'sis), the exposition or interpretation of the Scriptures. The science which lays down the principles of the art of sacred interpretation is called *exegetics* or *hermeneutics*.

Exequa'tur (Lat. 'Let him accomplish'), a written recognition of a consul or commercial agent issued by the government to which he is accredited, and authorizing him to exercise his powers.

Exergue (egz-èrg'), the small space beneath the base line of a subject engraved on a coin or medal, left for the date, engraver's name, or something of minor importance.

Ex'eter, a city, river-port, and parliamentary and municipal borough of England, in the county of Devon, on the left bank of the Exe, 10 miles north-west from its outlet in the English Channel. It is pleasantly situated on the summit and slopes of an acclivity rising from the river, and has handsome squares, terraces, and streets. Amongst the objects of interest are the cathedral (founded 1112), the remains of the castle of Rougemont, the Guildhall, the Albert Memorial Museum, St. Michael's Church, &c. Exeter has iron-foundries, manufactories of agricultural implements, paper-mills, &c., and 'Honiton' lace is also made. By means of a canal vessels of 300 tons can reach the city. The largest vessels remain at Exmouth. Exeter is a place of remote antiquity, having been a British settlement long prior to the invasion of the Romans, by whom it was called *Isca Damnoniorum*. The city long returned two members to parliament, but lost one of them in 1885. Pop. 37,580.

Exeter College, OXFORD, a college, originally called Stapledon Hall, founded in 1314 by Walter de Stapledon, bishop of Exeter, who made a foundation for a rector

and twelve fellows. In 1404 Edmund Stafford, bishop of Exeter, added two fellowships and obtained leave to give the college its present name.

Exeter Hall, a large building on the north side of the Strand, London, opened in 1831. It is capable of containing over 3000 persons. In it the 'May Meetings' of the several religious societies are held. It is now the property of the Young Men's Christian Association.

Exfoliation, in surgery, the process by which a thin layer or scale of dead bone separates from the sound part.

Exhibition, a benefaction settled for the maintenance of undergraduates in the universities of England, the British colonies, and America. In Scotland such scholarships are called *bursaries*.

Exhibition, **INDUSTRIAL**, an exhibition of works of industry and art for the purpose of exciting public interest and promoting trade and manufactures. In 1798 an industrial exhibition of the products of French industry was held at Paris, and proved so successful that in 1802, during the consulate of Napoleon, another was held. The beneficial effects of these exhibitions were so obvious that a series of them was held at intervals, the eleventh and last being held at Paris in 1849. In Britain exhibitions of a more or less local nature had been held in Dublin (1829), Manchester, Liverpool, and Birmingham, and annually in London in the premises of the Society of Arts. All these had been generally successful, but the necessity of holding one on an international scale was first brought fairly before the public in 1848 by Prince Albert. A royal commission was issued on 3d Jan. 1850, and a guarantee fund raised by voluntary subscription. A vast structure of iron and glass, the design of Joseph Paxton, was erected in Hyde Park, London, and was opened by Queen Victoria on the 1st of May, 1851. The entire area was about 19 acres; the number of exhibitors reached 15,000. The money drawn for admission was £505,107, which left a balance of £150,000 after paying all expenses. When the exhibition was over the building was taken down, and a great part of the material was used in the construction of Sydenham Crystal Palace, London. In 1855 the first French Exposition Universelle was opened in Paris. The buildings were erected in the Champs Elysées, and covered about 24 acres. There were in all about 24,000 exhibitors. This

was followed by the national exhibitions of the Dutch at Haarlem and the Belgians at Brussels, both in 1861, and the following year by the second great international exhibition held in London. The building, erected at South Kensington, covered about 17 acres. The aggregate number of visitors from 1st May to 31st October was 6,211,103, the money taken for admission amounted to £328,858. The entire cost of the undertaking was £321,000. There were 29,000 exhibitors. In 1865 an exhibition was held at Dublin, which, successful in other respects, was a pecuniary failure. The second French International Exhibition was opened on the 1st April, 1867, and closed on the 3d November. It was erected on the Champ de Mars, and covered about 37 acres. The exhibitors numbered nearly 50,000, the visitors about 10,000,000. On the 1st of May, 1871, the first of a series of British annual international exhibitions of fine arts and industry was opened by the Prince of Wales. The buildings were erected in the Horticultural Society's gardens, South Kensington. This was followed by the exhibitions of 1872, 1873, and 1874, but they having proved unsuccessful, the series ceased. In 1873 the first Austrian international exhibition was held in Vienna. A great exhibition was held at Philadelphia in 1876 upon the occasion of the centennial festival of the American declaration of independence. It occupied 60 acres, and had nearly 10,000,000 visitors. A third French International Exhibition was held at Paris in 1878, the area occupied amounting in all to 140 acres, the visitors numbering about 17,000,000. A fourth was held in 1889, the latter being partly intended to commemorate the centenary of the French Revolution. One of the features in connection with it is the famous Eiffel Tower of iron, 984 feet high, and thus more than 400 feet higher than any other structure. In 1883 a series of exhibitions began at South Kensington, London, where the exhibits were confined to articles having relation to a special department. To this series belonged The Fisheries Exhibition of 1883, the Health Exhibition of 1884, the Exhibition of Inventions in 1885, and the Exhibition of Colonial and Indian products in 1886. This latter was visited by 5,550,749 persons. Besides these Edinburgh had an International Exhibition of Industry, Science, and Arts in 1886, visited by 2,769,632 persons. In 1887 a Royal Jubilee Exhibition of Arts and Manufactures was opened at

EXMOOR — EXOGENOUS PLANTS.

Manchester, and was visited by 4,765,000 persons. In the following year a great International Exhibition of Industry, Science, and Art was held at Glasgow, and attracted during the season 5,748,379 visitors. In 1892-93 an International Exhibition of majestic proportions was held in Chicago, Illinois, to commemorate the 400th anniversary of the discovery of America. In 1898 the Trans-Mississippi Exposition at Omaha, Neb., was unqualifiedly successful.

Exmoor', a wild and hilly district of England, in the extreme south-west of Somers-



Viscount Exmouth.

setshire, extending also into Devonshire, formerly a forest.

Ex'mouth, a town of England, in Devonshire, 10 miles s.s.e. of Exeter, at the mouth of the Exe. It is picturesquely situated, and is one of the handsomest sea-bathing places on the Devonshire coast. The chief industries are lace-making and the fisheries. Pop. 6245.

Exmouth, EDWARD PELLEW, VISCOUNT, a British naval officer, born in 1757. He went to sea at the age of thirteen, served as midshipman in the *Blonde* frigate during the American war, and greatly distinguished himself at Lake Champlain. In 1782 he was made a post-captain for a brilliant action in the *Pelican*, and on the outbreak of the war in 1793 was appointed to the command of the frigate *La Nymphe*. From this time till the peace in 1802 he was employed in active service. In 1804, on the resumption of hostilities, he was sent to take the chief command on the East India station,

in the *Culloden*, of seventy-four guns; and here he remained till 1809, when he had attained the rank of vice-admiral. His next appointment was the command of the fleet blockading the Scheldt. In 1814 he was made Baron Exmouth with a pension of £2000 per annum. In 1816 he proceeded to Algiers in command of a combined fleet of twenty-five English and Dutch ships to enforce the terms of a treaty regarding the abolition of Christian slavery which the dey had violated. He bombarded the city for seven hours, and inflicted such immense damage that the dey consented to every demand. Twelve hundred Christian slaves were by this exploit restored to liberty. Lord Exmouth was raised to the dignity of a viscount for this service. D. Jan. 23, '33.

Exocetus, EXOCÆTUS. See *Flying-fish*.

Exodus (Greek, *exodos*, a going out), the name given in the Septuagint to the second book of the Pentateuch, because it describes the departure of the Israelites from Egypt. The contents of the book are partly historical, describing the departure of the Israelites from Egypt, and partly legislative, describing the promulgation of the Sinaitic law. One of the difficulties connected with this book is that, according to Scriptural chronology, the residence of the Israelites in Egypt was only 215 years, and it seems incredible that in this time 'the threescore and ten souls' who accompanied Jacob to Egypt could have become the two and a half millions who left with Moses.

Exogenous Plants (eks-oj'e-nus), or Ex-

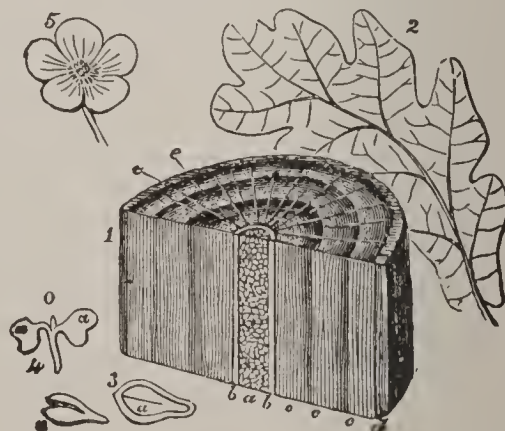

Exogenous Plants.

1, Section of a Branch of three years' growth. *a*, Medulla or pith. *b*, Medullary sheath. *cc*, Medullary rays. *cc*, Circles of annual growth. *d*, Bark. 2, Netted veined Leaf of Exogen (Oak). 3, Dicotyledonous Seed of Exogen. *a a*, Cotyledons. 4, Germination of Dicotyledonous Seed. *a a*, Seed-leaves or Cotyledons. *o*, Plumula. 5, Exogenous Flower (Crowfoot).

EXOGENS, those plants whose stems are formed by successive additions to the outside. The

exogens are the largest primary class of plants in the vegetable kingdom, and their increase by annual additions of new layers to the outside of their stems, formed in the cambium between the wood and the bark, is a feature in which they differ essentially from endogens, whose wood is formed by successive augmentations from the inside. The concentric circles thus annually formed, distinguishable even in the oldest trees, aid in computing the age of the tree. The stem and branches also exhibit a central pith and medullary rays extending outwards to the bark. All the trees of cold climates, and the principal part of those in hot, are exogenous, and are readily distinguished from those that are endogenous by the reticulated venation of their leaves, and by their seeds having two cotyledons (dicotyledonous). The parts of the flower are generally in fours or fives.

Ex'orcism, the casting out of evil spirits by certain forms of words or ceremonies. An opinion prevailed in the ancient church that certain persons, those particularly who were afflicted with certain diseases, especially madness and epilepsy, were possessed by evil spirits. Over such persons forms of conjuration were pronounced, and this act was called *exorcism*. There were even certain men who made this a regular profession, and were called *exorcists*. Exorcism still makes a part of the beliefs of some churches. In the R. Cath. Church exorcist is one of the inferior orders of the clergy.

Ex'osmose, the opposite of *endosmose* (which see).

Exostem'ma, a genus of plants, nat. order Cinchonaceæ. The species are trees or shrubs, natives of tropical America and the West Indies. *E. caribæum* and *E. floribunda* possess properties similar to those of the true cinchona, but without any trace of either cinchonine or quinine.

Exosto'sis, in med., a bony excrescence or growth from one of the bony structures of the body. It is generally found at the end of long bones near the joints, and in connection with the skull. Amputation is generally required.

Exot'ic, belonging to foreign countries; a term used especially of plants. Exotic plants are such as belong to a soil and climate entirely different from the place where they are raised. They are nearly always greenhouse or hothouse plants.

Expansion, in physics, is the enlargement or increase in the bulk of bodies, in conse-

quence of a change in their temperature. This is one of the most general effects of heat, being common to all bodies whatever, whether solid or fluid. The expansion of fluids varies considerably, but, in general, the denser the fluid, the less the expansion; thus water expands more than mercury, and spirits of wine more than water; and, commonly, the greater the heat, the greater the expansion; but this is not universal, for there are cases in which expansion is produced, not by an increase, but by a diminution of temperature. Water, in cooling, ceases to contract at 42° F.; and at about 39°, just before it reaches the freezing point (32°), it begins to expand again, and more and more rapidly as the freezing point is reached. This expansion is about one-eleventh of its bulk, and accounts for the bursting of pipes, &c., when water is freezing in them.

Expectation, in the doctrine of chances, the value of any prospect of prize or property depending upon the happening of some uncertain event. A sum of money in *expectation* upon a certain event has a determinate value before that event happens. If the chances of receiving or not receiving a hundred pounds, when an event arrives, are equal; then, before the arrival of the event the expectation is worth half the money.—*Expectation of life*, the probable duration of the life of individuals of any given age. A rough estimate of any one's expectation of life is made by calculating two-thirds of the difference between his or her present age and eighty.

Expec'torants, in pharmacy, medicines which favour the discharge of mucus from the windpipe and air-passages of the lungs. Such are the stimulating gums and resins, squills, ipecacuanha, &c.

Exper'iment, an operation designed to discover some unknown truth, principle, or effect, or to establish it when discovered. It differs from observation in the fact that the phenomena observed are, to a greater or less extent, controlled by human agency. Experiment distinguishes the modern method of investigating nature, and to it we owe the rapid strides made in chemistry, physics, &c.

Expert', a person eminently skilled in any particular branch or profession; specifically, a scientific or professional witness who gives evidence on matters connected with his profession, as an analytical chemist or a person skilled in handwriting.

Exploits', RIVER OF, a river which traverses nearly the whole of Newfoundland from S.W. to N.E., and falls into the Bay of Exploits. It is about 150 miles long, and is navigable for steamers 12 miles.

Explo'sion, a sudden bursting, generally due to the rapid production of gaseous matter from solids or liquids. Thus the explosion of gunpowder is due to the sudden formation and expansion of gases into which the powder is converted by chemical agency. Explosions are often caused by the elastic force of steam confined in boilers, &c.

Explo'sives are compounds practically available in war, in mining, and in general use for the sudden development of immense force. They comprise gunpowder, gun-cotton, nitro-glycerine with its compounds dynamite, litho-fracteur, &c. An Explosives Act for Britain, to amend the law with respect to the manufacturing, keeping, selling, carrying, and importing explosive substances, was passed in 1875; and an amendment act to check the use of explosives for felonious purposes became law in 1883.

Expo'nent, in algebra, the number or figure which, placed above a root at the right hand, denotes how often that root is repeated or how many multiplications are necessary to produce the power. Thus a^2 denotes the second power of the root a , that is, a multiplied by a ; a^4 denotes the fourth power. The figure is the *exponent* or index of the power. To express the roots of quantities fractional exponents are used: thus $a^{\frac{1}{2}}$, $a^{\frac{1}{3}}$, $a^{\frac{1}{n}}$, denote the square root, the cubic root, and the n^{th} root of a .

Ex Post Facto, in law, by something done after and bearing upon something previously done; thus a law is said to be *ex post facto*, or retrospective, when it is enacted to punish an offence committed before the passing of the law.

Express', a special message, messenger, or conveyance, sent on a particular occasion. The name is given to any regular provision made for the speedy transmission of messages, parcels, commissions, and the like; and particularly to a railway train which travels at a specially high rate of speed, stopping only at the principal stations.

Expressed Oils, in chemistry, are those which are obtainable from bodies only by pressing, to distinguish them from mineral and essential oils, which last are, for the most part, obtained by distillation.

Extension, (1) In physics and metaph.,

that property of a body by which it occupies a portion of space. Extension is an essential as well as a general property of matter, for it is impossible to form a conception of matter, however minute may be the particle, without connecting with it the idea of its having a certain bulk and occupying a certain quantity of space. Every body, however small, must have length, breadth, and thickness; that is, it must possess the property of extension. Figure or form is the result of extension, for we cannot conceive that a body has length, breadth, and thickness, without its having some kind of figure, however irregular. (2) In logic, *extension* is the extent of the application of a general term, that is, the objects collectively which are included under it; thus, the word figure is more extensive than triangle, circle, parallelogram, &c.; European more extensive than French, Frenchman, German, &c. Matter and mind are the most extensive terms of which any definite conception can be formed. Extension is contrasted with *comprehension* or *intension*.

Extincteur (eks-tan-teur), an apparatus for the extinction of fire, consisting of a metallic case containing water and materials for generating carbonic acid. When required the materials are brought into contact by pushing a rod which breaks a bottle containing acid, the gas mixes with the water, and the pressure generated is sufficient to project the water charged with the gas to a distance of 40 or 50 feet.

Ex'tract, a term to denote all that can be dissolved out of a substance by a specified menstruum, such as water, alcohol, ether, &c. In modern pharmacy the term is applied to two kinds of preparation from vegetables. One is got by digesting the plant in water or other solvent, and evaporating or distilling away the excess of solvent until the extracted matter is sufficiently inspissated. The other is got by bruising the plant in a mortar, separating the juice, warming it until the green colouring matter separates, and filtering it off. The juice is next heated until the albumen coagulates, and again filtered. The juice is now evaporated to a syrup, the green colouring matter added and well mixed, and the evaporation is thereafter continued until the required concentration is attained. Extracts must be capable of being redissolved, so as to form a solution like that from which they were derived. Extracts are used in cookery, medicine, and

the manufacture of perfumery.—*Extract of Meat* (*extractum carnis*) is a soft, yellowish-brown, solid, or very thick syrup, which is employed as a portable soup. It is now manufactured on the large scale by processes proposed by Liebig.

Extradition, the act by which a person accused of a crime is given up by the government in whose territories he has taken refuge to the government of which he is a subject. Treaties have been entered into by the U. States with almost all civilized countries for the apprehension and extradition of persons charged with particular offences, such as murder, robbery, embezzlement by public officers, arson, rape, piracy, &c. The constitution of the U. States provides that 'a person charged in any state with treason, felony, or other crime, who shall flee from justice and be found in another state, shall, on demand of the executive authority of the state from which he fled, be delivered up to be removed to the state having jurisdiction of the crime.'

Extravaganza, in music, the drama, &c., a species of composition designed to produce effect by its wild irregularity and incoherence; differing from a burlesque in being an original composition and not a mere travesty.

Extravasation, an escape of some fluid, as blood or urine, from the vessel containing it. *Blood extravasation*, in contusions and other accidents, is when blood-vessels are ruptured by the injury, and the blood finds its way into the neighbouring tissues. In some accidents to the urethra and bladder extravasation of urine is a very serious occurrence.

Extreme Unction has been, since the 12th century, one of the seven sacraments of the Catholic Church. It is performed in cases of mortal disease by anointing in the form of a cross, the eyes, ears, nose, mouth, hands, feet, and reins (in the case of males). It is administered after confession and the eucharist, and is believed to remove the last stains of sin. It can only be administered by a bishop or priest, and is not applied in the case of young children or excommunicated persons.

Extremities, the limbs, as distinguishing them from the other divisions of the animal, the head and trunk. The extremities are four in number, in man named upper and lower; in other animals anterior and posterior.

Exuma, GREAT and LITTLE, two of the

Bahama Islands. The former is 30 miles long and 3 miles wide, and has a good harbour. Pop. 2300.

Exuvia, the cast-off parts or coverings of animals, as the skins of serpents and caterpillars, the shells of lobsters, &c.

Eyalet (ī'a-let), a former administrative division of the Turkish empire, subdivided into sanjaks or provinces, and kazas or districts. It was ruled by a pasha, and gave place to the vilayet on the reorganization of the empire in 1871.

Eyck (ik), HUBERT and JAN VAN, brothers, famous painters of the old Flemish school, born at Maaseyck, Hubert in 1366, Jan probably about 1390. They lived first at Bruges, whence the younger brother is called John of Bruges, and afterwards at Ghent, to which they removed about 1420. Here they executed the celebrated Adoration of the Lamb for the cathedral of Ghent; a painting which, in its different parts, contains above three hundred figures, and is a masterpiece. It was in two horizontal divisions, comprising ten panels, of which only the two central ones remain at Ghent, the others being at Berlin. Hubert did not live to see it completed. He died at Ghent (1426), as did also his sister Margaret, who was likewise a painter (1431). Jan finished the work in 1432, and returned to Bruges, where he remained till his death, which took place in 1441, and executed several excellent pieces. His reputation became very great even during his lifetime, by his share in the introduction of oil-painting; the original invention of which has been incorrectly ascribed to him by many. Jan van Eyck also introduced improvements in linear and aerial perspective, and in painting upon glass.

Eye, the visual apparatus of animals, consisting in man of the globe of the eye, the muscles which move it, and of its appendages, which are the eyelids and eyebrows, and the lachrymal apparatus. The walls of the globe of the eye are formed principally of two fibrous membranes; one white and opaque — the *sclerotic* (Gr. *sklēros*, hard) — which envelops two-thirds of the globe posteriorly; and the other transparent, and resembling a horny plate, whence its name, *cornea* (Lat. *corneus*, horny). The sclerotic is a tough fibrous coat, and is the part to which the phrase 'white of the eye' is applied. In the front of the globe the sclerotic is abruptly transformed into the transparent portion (the cornea), which is circular, and which forms a window through

EYE.

which one can see into the interior. A mucous membrane, the *conjunctiva*, so named because it unites the eye to the lid, spreads over the anterior portion of the globe, and then folds back on itself and lines the internal surface of the eyelids. On the internal surface of the sclerotic is a vascular membrane called the *choroid*. This is essentially the blood-vessel coat of the eyeball. The front part of the choroid terminates about the place where the sclerotic passes into the cornea in a series of ridges, the *ciliary processes*. The circular space thus left in front by the termination of the choroid is occupied

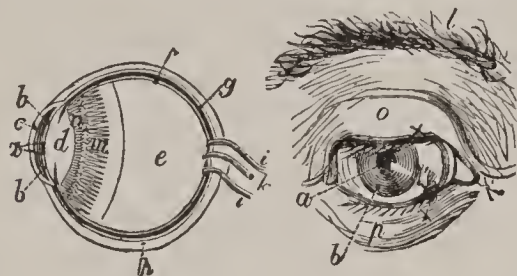

Human Eye.

Interior. *a*, Pupil. *b*, Iris. *c*, Cornea. *d*, Crystalline lens. *e*, Vitreous humour. *f*, Retina. *g*, Choroid coat. *h*, Sclerotic coat. *i i*, Central vein of the retina. *k*, Optic nerve. *m*, Ciliary processes. *n*, Ciliary ligament or circle.
Exterior. *l*, Eyebrow. *o p*, Upper and lower eyelid. *x x*, Eyelashes. The pupil and iris are also shown at *a* and *b* respectively.

by the *iris*, a round curtain, the structure seen through the cornea, differently coloured in different individuals. In its centre is a round hole, the *pupil*, which appears as if it were a black spot. The *iris* forms a sort of transverse partition dividing the cavity of the eyeball into two chambers, a small anterior chamber filled with the *aqueous humour*, and a large posterior chamber filled with *vitreous humour*. The *iris* consists of a framework of connective tissue, and its posterior surface is lined by cells containing pigment which gives the colour to the eye. In its substance are bundles of involuntary muscular fibres, one set being arranged in a ring round the margin of the pupil, the other set radiating from the pupil like the spokes of a wheel. In a bright light the circular fibres contract and the pupil is made smaller; but in the dark these fibres relax and cause the pupil to dilate more or less widely, thus allowing only that quantity of luminous rays to enter the eye which is necessary to vision. Just behind the pupil is the *crystalline lens*, resembling a small, very strongly magnifying glass, convex on each side, though more so behind. The greater or less convexity of the surfaces of the lens determines whether the

vision is long or short. The internal surface of the choroid, or rather the pigmentary layer which covers it, is lined by the *retina* or nervous tunic upon which the objects are depicted that we see. It appears to be formed by the expansion of the optic nerve, which enters the eye at its posterior part about one-tenth of an inch to the inner side of the axis of the eyeball, and forms at the bottom of the globe an enlargement, which is called the *papilla of the optic nerve*. Microscopists describe the retina as being composed of five, or even eight layers, of which the internal one is vascular and in contact with the vitreous; the external one, very important in a physiological point of view, is the *membrane of Jacob*. It is composed of cones and cylinders or *rods*, joined together like the stakes of a palisade, perpendicular to the plane of the membrane, and forming by their free extremities a mosaic, each microscopic division of which is about 0.001 of a line in diameter according to Robin, and 0.0008 of a line according to Helmholtz; and represents a section of a rod. These rods and cones are believed to be the agents by whose aid the waves of light become transformed into the stimulus of a sensation. The ocular globe is put in motion in the orbit by six muscles, grouped two by two, which raise or lower the eye, turn it inward or outward, or on its antero-posterior axis. In these movements the centre of the globe is immovable, and the eye moves round its transverse and vertical diameters. These three orders of movements are independent of each other, and may be made singly or in combination, in such a manner as to direct the pupil towards all points of the circumference of the orbit. Each eye is furnished with two eyelids, moved by muscles, which shield it from too much light and keep it from being injured. They are fringed with short fine hairs called eyelashes; and along the edge of the lids is a row of glands similar to the sebaceous glands of the skin. The eyebrows, ridges of thickened integument and muscle, situated on the upper circumference of the orbit and covered with short hairs, also regulate to some extent the admission of light by muscular contraction. In reptiles, some fishes (sharks, &c.), in birds, and in some mammals a third eyelid or nictitating membrane is present, and can be drawn over the surface of the eye so as to clear it of foreign matters, and also to modify the light. The lachrymal apparatus is composed of, firstly, the *lachrymal gland*,

which lies in a depression of the orbital arch; secondly, of the *lachrymal canals*, by which the tears are poured out upon the conjunctiva a little above the border of the upper lid; thirdly, the *lachrymal ducts*, which are destined to receive the tears after they have bathed the eye, and of which the orifices or *lachrymal points* are seen near the internal commissure of the lids; fourthly, the *lachrymal sac*, in which the lachrymal ducts terminate, and which empties the tears into the *nasal canal*. The tears, by running over the surface of the conjunctiva, render it supple and facilitate the movements of the globe and eyelids by lessening the friction. The influence of moral or physical causes increases their secretion, and when the lachrymal ducts do not suffice to carry them off they run over the lids.

Vision.—The retina renders the eye sensible of light, and we may therefore consider it as the essential organ of vision. The function of the other portions is to converge the luminous rays to a focus on the surface of the retina, a condition necessary for distinct vision and the clear perception of objects. The visual impressions are transmitted from the retina to the brain by means of the optic nerve, of which that membrane appears to be the expansion. The two optic nerves converge from the base of the orbit toward the centre of the base of the skull, where there is an interlacement of their fibres in such a manner that a portion of the right nerve goes to the left side of the brain, and a part of the left nerve to the right side; this is called the *chiasma* or *commissure* of the optic nerves. The principal advantage of having two eyes is in the estimation of distance and the perception of relief. In order to see a point as single by two eyes we must make its two images fall on corresponding points of the retinas; and this implies a greater or less convergence of the optic axes according as the object is nearer or more remote. To accommodate the eye to different distances the lens is capable of altering itself with great precision and rapidity. When we look at a near object the anterior surface of the lens bulges forward, becoming more convex the nearer the object; the more distant the object the more the lens is flattened. When the transparency of the cornea, the crystalline lens, or any of the humours, is destroyed, either partially or entirely, then will partial or total blindness follow, since no image can be formed upon the retina;

but although all the humours and the cornea be perfectly transparent, and retain their proper forms, which is likewise necessary to distinct vision, yet, from weakness or inactivity of the optic nerve, or injury of the central ganglia with which it is connected, weakness of sight or total blindness may ensue. Defective vision may also arise from the crystalline lens being so convex as to form an image before the rays reach the retina (a defect known as short sight or myopia), in which case distinct vision will be procured by interposing a concave lens between the eye and the object of such a curvature as shall cause the rays that pass through the crystalline lens to meet on the retina; or the lens may be too flat, as is the case in old age, a defect which is corrected by convex lenses. In the lower forms of life the organs of sight appear as mere pigment spots. Ascending higher, simple lenses or refracting bodies occur. Insects, crustaceans, &c., have large masses of simple eyes or ocelli aggregated together to form compound eyes—the separate facets or lenses being optically distinct, and sometimes numbering many thousands. In the molluscs well-developed eyes approaching in structure those of the highest animals are found; and in all vertebrate animals the organ of vision corresponds generally to what has been described, though they vary much in structure and adaptation to the surroundings of the animal.

Eye, in agriculture and gardening, signifies a bud or shoot of a plant or tuber.

Eye (ā), a municipal borough, England, county Suffolk, 19 miles north of Ipswich. Up till 1885 it sent a member to parliament, and it still gives name to a parl. div. of the county. Pop. 2296.

Eyebright (*Euphrasia officinālis*), a small plant belonging to the natural order Scrophulariaceæ, which is common in Britain and most parts of Europe, in North Asia, &c. It is annual, from 3 to 8 inches high, often much branched. The whole plant has a bitter taste. Under the name of *euphrasy* it formerly enjoyed a great reputation in diseases of the eyes.

Eyelid. See *Eye*.

Eyemouth, a fishing town of Berwickshire, Scotland, at the mouth of the Eye, an important place in the 13th century. Pop. 2825.

Eye-piece, in a telescope, microscope, or other optical instrument, the lens, or combination of lenses to which the eye is applied.

Eylau (ī'lou), a small town, about 28 miles distant from Königsberg, in Prussia, famous for a bloody battle fought between Napoleon and the allied Russians and Prussians, on the 7th and 8th of February, 1807. Both sides claimed the victory. The loss of the allies was about 20,000 men, while that of the French must have been considerably greater.

Eyre (ār), EDWARD JOHN, Australian explorer and colonial governor, born in Yorkshire 1815. He went to Australia in 1833. In 1839 he discovered Lake Torrens, and in 1840 explored its eastern shores and the adjacent Flinders Range. He then commenced his perilous journey along the shores of the Great Australian Bight, and reached King George's Sound, in Western Australia, a distance of 1200 miles, with a single native boy, having left Adelaide more than a year before. In 1845 he published *Discoveries in Central Australia*. After filling several governorships he was appointed governor of Jamaica in 1862. In 1865 he was confronted with a negro rebellion which he crushed with some severity, and was recalled. On his return to England John Stuart Mill and others took measures to try him for murder, but failed. Carlyle was one of his most strenuous defenders.

Eyre, LAKE, a large salt-water lake of South Australia. Area about 4000 sq. m., but it is subject to great fluctuations in size.

Eze'kiel ('God shall strengthen'), the third

of the great prophets, a priest, and the son of Buzi. He was carried away when young (about 599 B.C.) into the Babylonish captivity. His prophetic career extended over a period of 22 years, from the 5th to the 27th year of the captivity. The Book of Ezekiel contains predictions made before the fall of Jerusalem, 586 B.C. (chaps. i.-xxiv.); prophecies against some of the neighbouring tribes (chaps. xxv.-xxxii.); prophecies concerning the future of Israel (xxxiii.-xxxix.); and a series of visions relating to the circumstances of the people after the restoration.

Ezra, a celebrated Jewish scribe and priest. Under his guidance the second expedition of the Jews set out from Babylon to Palestine under the reign of Artaxerxes I., about 458 B.C. The important services rendered by Ezra to his countrymen on that occasion, and also in arranging, and in some measure, it is believed, settling the canon of Scripture, are specially acknowledged by the Jews, and he has even been regarded as the second founder of the nation. Josephus states that he died in Jerusalem; others assert that he returned to Babylon, and died there at the age of 120 years. The Book of Ezra contains an account of the favours bestowed upon the Jews by the Persian monarchs, the rebuilding of the temple, Ezra's mission to Jerusalem, and the various regulations and forms introduced by him. It is written partly in Hebrew and partly in Chaldee, which have led some to conclude that it is the work of different hands.

F.

F, the sixth letter of the English alphabet, is a labio-dental articulation, formed by the passage of breath between the lower lip and the upper front teeth. It is classed as a surd spirant, its corresponding sonant spirant being *v*, which is distinguished from *f* by being pronounced with voice instead of breath, as may be perceived by pronouncing *ef*, *ev*. (In *if*, *of*, however, *f* is = *v*.) The figure of the letter F is the same as that of the ancient Greek digamma, which it also closely resembles in power.

F, in music, is the fourth note of the diatonic scale.

Fa, the name given by Guido to the fourth note of the natural diatonic scale of C.

Faam-tea, or **Faham-tea**, a name given to the dried leaves of the *Angræcum frag-*

rans, an orchid growing in the Mauritius and in India, and much prized for the fragrance of its leaves, an infusion of which is used as a stomachic and as an expectorant in pulmonary complaints.

Faber, FREDERICK WILLIAM, D.D., a theologian and hymn-writer, the nephew of George Stanley Faber, born at Durham in 1814. In 1845 he became a convert to Roman Catholicism, and founded the oratory of St. Philip Neri, afterwards transferred to Brompton. He died Sept. 26, 1863.

Faber, REV. GEORGE STANLEY, D.D., an English popular theological writer, born in 1773, near Bradford in Yorkshire. He was educated at Oxford, and became a fellow of Lincoln College. He was appointed Bampton Lecturer in 1801; became a prebend in

Salisbury Cathedral in 1831, and master of Sherburn Hospital, Durham, in 1832. He died 27th Jan. 1854. Amongst his principal writings are *Horæ Mosaicæ*, *The Doctrine of Regeneration*, *A Dissertation on the Prophecies*.

Fabii (fā'bi-ī), an ancient and renowned family of Rome, who, having undertaken the duty of defending Roman territory against the incursions of the Veientes, established themselves at a post on the river Cremera. Being drawn into an ambush they were killed to a man (B.C. 477). A boy who happened to be left in Rome became the second founder of the family. Among its celebrated members in after-times was **FABIUS MAXIMUS**, whose policy of defensive warfare was so successful against Hannibal in the second Punic war (B.C. 217—); and **FABIUS PICTOR**, who lived about the same time and wrote a history of Rome, thus being the earliest Roman historian.

Fable, in literature, a term applied originally to every imaginative tale, but confined in modern use to short stories, either in prose or verse, in which animals and sometimes inanimate things are feigned to act and speak with human interests and passions for the purpose of inculcating a moral lesson in a pleasant and pointed manner. The fable consists properly of two parts—the symbolical representation and the application, or the instruction intended to be deduced from it, which latter is called the *moral* of the tale, and must be apparent in the fable itself. The oldest fables are supposed to be the oriental; among these the Indian fables of Pilpay or Bidpai, and the fables of the Arabian Lokman, are celebrated. (See *Bidpai* and *Lokman*.) Amongst the Greeks, *Æsop* is the master of a simple but very effective style of fable. The fables of Phædrus are a second-rate Latin version of those of *Æsop*. In modern times Gellert and Lessing among the Germans, Gay among the English, the Spanish Yriarte, and the Russian Ivan Kriloff, are celebrated. The first place, however, amongst modern fabulists belongs to the French writer La Fontaine. See *La Fontaine*.

Fabliaux (fab'li-ō), in French literature, the short metrical tales of the Trouvères, or early poets of the Langue d'Oil, composed for the most part in the 12th and 13th centuries. These productions were intended merely for recitation, not for singing, and had as their principal subjects the current

gossip and news of the day, which were treated in a witty and sarcastic way. The fabliaux lashed not only the clergy and nobility in their degeneracy, but even mocked the religious chivalrous spirit, and the religious and knightly doctrines and ceremonies.

Fabria'no, an Episcopal city of Italy, province of Ancona. Pop. 5593.

Fabricius, **CAIUS** (with the cognomen **LUSCINUS**), a pattern of ancient Roman virtue in his fearlessness, integrity, moderation, and contempt of riches. After having conquered the Samnites and Lucanians, and enriched his country with the spoils, of which he alone took nothing, he was sent on an embassy to Pyrrhus, king of Epirus, who tried in vain to corrupt him by large presents. When consul in 279 B.C. Fabricius delivered up to Pyrrhus his treacherous physician, who had offered to poison his royal master for a sum of money. In gratitude for the service the king released the Roman prisoners without ransom. In 275 B.C. Fabricius was chosen censor. He died about 250 B.C.

Fabricius, **JOHANN ALBRECHT**, a German scholar, born at Leipzig in 1668, became professor of rhetoric and moral philosophy at Hamburg, and published many learned works, amongst which are his *Bibliotheca Latina*, *Bibliotheca Ecclesiastica*, *Bibliotheca Antiquaria*. He died in 1736.

Fabricius, **JOHANN CHRISTIAN**, German entomologist, born 1748. After studying at Copenhagen, Leyden, Edinburgh, and under Linnæus at Upsala, he obtained the post of professor of natural history in the University of Kiel. In 1775 appeared his *System of Entomology*, which gave to this science an entirely new form. In 1778 he published his *Philosophia Entomologica*, written upon the plan of the well-known *Philosophia Botanica* of Linnæus. He died March 3, 1808.

Façade (fa-sād' or fa-säd'), the face, front view, or principal elevation of a building. It usually contains the principal entrance.

Facciolati (fât-cho-lä'tē) **JACOPO**, Italian classical scholar, born 1682, died 1769; professor in the University of Padua. The most important work with which he was connected was the *Totius Latinitätis Lexicon*, compiled by Forcellini under his direction and with his co-operation.

Face, the front part of the head, the seat of most of the senses. The bony basis of the face, exclusive of the thirty-two teeth (these not being in the strict sense bones), is com-

posed of fourteen bones, called, in anatomy, the *bones of the face*. The anterior part of the skull (*os frontis*) also forms an important feature of the face. Of all these bones the lower jaw only is movable, being articulated with the base of the skull. The other bones are firmly joined together and incapable of motion. In brutes the jaws project much more than in men, and form the prominent feature of the face, while the forehead recedes. (See *Facial Angle*.) The face of birds comprehends the ophthalmic regions, cheeks, temples, forehead and vertex; the face of insects includes all between the proboscis and the prothorax.

Facet, FACETTE (*fas'et, fa-set'*; literally a little face), one of a series of small circumscribed plane surfaces, as one of the small plane surfaces of a crystal or a cut gem.

Face'tiæ, humorous sayings, witticisms, jests. There have been many collections of such. Amongst the most notable are the *Jests of Hierocles*, an old Greek collection, the *Liber Facietiarum* of Poggio Bracciolini, the *Apophthegms* of Bacon, *Joe Miller's Jest-Book*, &c.

Facial Angle, an angle of importance in the method of skull measurement introduced by Camper, the Dutch anatomist, whosought

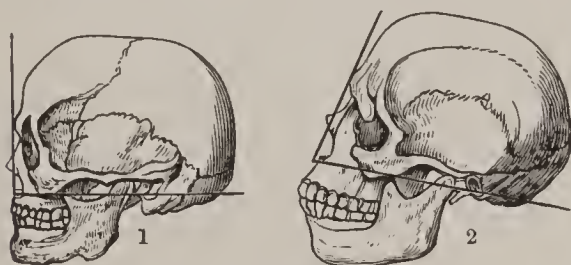

Facial Angle.
1, European. 2, Negro.

to establish a connection between the magnitude of this angle and the intelligence of different animals and men, maintaining that it is always greater as the intellectual powers are greater. Suppose a straight line drawn at the base of the skull, from the great occipital cavity across the external orifice of the ear to the bottom of the nose, and another straight line from the bottom of the nose, or from the roots of the upper incisors, to the most prominent part of the forehead, then both lines will form an angle which will be more or less acute. In apes this angle is only from 45° to 60° ; in the skull of a negro, about 70° ; in a European, from 75° to 85° . In another mode of drawing the lines the angle included between them varies in man from 90° to 120° , and is more capable of compari-

son among vertebrate animals than the angle of Camper. This angle though of some importance in the comparison of races, is fallacious as a test of individual capacity.

Facial Nerve, a nerve of the seventh pair of cranial nerves, a motor nerve which supplies the muscles of expression on either side of the face. Paralysis of this nerve produces *facial paralysis*, the result of which is that the affected side is smooth, unwrinkled, and motionless, the eyelids are wide open and cannot be closed, and the muscles of the sound side having it all their own way drag the mouth to that side.

Factor, in arithmetic, the multiplier and multiplicand, from the multiplication of which proceeds the product; thus 7 and 4 are the factors of 28. In algebra any expression which is considered as part of a product is considered a factor.

Factor, in commerce, an agent employed to do business for another in buying or selling, or in the charge of property. A factor seems to differ from a broker in holding a wider and more discretionary commission from his employer, in being able to buy and sell in his own name, and in having a lien on goods for his outlay; but the difference depends so much upon the usage of the particular trade, or upon the special instructions constituting the agency, that no exact line of demarkation can be drawn between them. The term factor has in common usage generally given place to the terms agent and broker, the former applied in the more general, the latter in the more restricted sense. It is still retained in some special cases, as in that of house factors and factors on landed property in Scotland, who have charge of the letting and general management of house property, farms, &c.; called in England estate agents.

Fact'ory (from *factor*), a name which appears originally to have been given to establishments of merchants and factors resident in foreign countries; it now more commonly signifies a place in which the various processes of a particular manufacture are carried on simultaneously. The rapid growth of factories in this sense is a comparatively recent development of industry, resulting from the free use of machinery and the consequent subdivision of labour. Amongst the advantages of the factory system are generally counted: 1st, increased productiveness arising from the minute division of labour; 2d, the mechanical accuracy and the cheapness of the product

turned out by machinery; 3d, the facilities for union and co-operation for common improvement afforded by bringing large masses of workmen together. But this last consideration is probably more than counterbalanced by the smaller amount of independent intelligence called forth in the individual worker, through the monotony of the minutely subdivided operations. Decided disadvantages of the factory system are the unhealthiness of the crowded rooms, where the air is full of deleterious elements; and the increasing demand on the labour of women and children, interfering as it does with the economy of domestic life. See also next article.

Factory Acts, acts passed for the regulation of factories and similar establishments. Considering that women and children were not qualified fully to protect themselves against the strain of competition, the British legislature has passed a series of acts to regulate the conditions of their employment in factories. The immediate occasion of the first act passed to regulate factory employment in England was the outbreak of an epidemic disease which committed great havoc among the younger persons employed in factories in the district round Manchester at the beginning of the present century. An act was passed (1802) in which provision was made for the regular cleansing and ventilation of mills and factories, and also for limiting the hours of labour to twelve daily. In 1819 an act followed which prescribed an hour and a half for meals in the course of a working day, and prohibited children under nine years of age being employed in factory work at all. Various acts were passed up to 1878, when what is known as the Factory and Workshop Act was passed. It consolidates the previous series of statutes, and may be said to contain practically all the law dealing with the subject. It has general provisions regarding drainage, ventilation, and fencing of dangerous machinery, &c. In textile factories the hours of labour for women are restricted to ten, with Saturday for a half-holiday. The hours for children (those under fourteen years of age) are fixed at half of those allowed to women and young persons ('young persons' being defined as those between fourteen and eighteen). Provision is made for holidays and for attendance at school of children employed in factories. Special provisions for particular kinds of factories are made by separate acts, and under these the employ-

ment of females and young persons is regulated in bleaching and dyeing works, lace-factories, manufactories of earthenware, lucifer matches, percussion caps, cartridges, blast-furnaces, copper-mills, forges, foundries, manufactories of machinery, metal, india-rubber, gutta-percha, paper, glass, tobacco, letterpress printing, bookbinding, &c. In all the States of the American Union in which the factory is an industrial feature there is some legislation relative to the employment of women and children. Attention is given to the age of children employed, and attendance at public schools for a certain period each year is obligatory. The daily hours of labor are regulated. In some States the belting, shafting, etc., employed must be securely guarded. Penalties for violation of these provisions are designated.

Fac'ulæ, certain luminous spots sometimes visible on the sun's disc. These portions have a different spectrum from the other bright parts of the sun, as well as from the maculæ or dark sun-spots. See *Sun*.

Faculties, COURT OF, in English law, a jurisdiction or tribunal belonging to the archbishop. It does not hold pleas in any suits, but has power to grant licenses or dispensations, such as, to marry without banns, to remove bodies previously buried, &c.

Faculty, the members taken collectively of the medical or legal professions; thus we speak of the medical faculty, the faculty of advocates. The term is also used for the professors and teachers collectively of the several departments in a university; as, the faculty of arts, of theology, of medicine, or of law.

Faculty, in law, is a power to do something, the right to do which the law admits, or a special privilege granted by law to do something which would otherwise be forbidden.

Fæces, the excrementitious part evacuated by animals. It varies of course with different species of animals, according to their diet. The main constituents are unassimilable parts of the food, on which the digestive process has no effect, and other portions, quite nutritious, but which have escaped digestion, also certain waste matters, &c. In disease the composition varies extremely.

Faed (fād), JOHN, R.S.A., artist, born in Kirkcudbrightshire in 1820, showed artistic talent at an early age. In 1841 he went to Edinburgh to study, and some years later

acquired considerable reputation. Among his principal works are: Shakspeare and his Contemporaries; An Incident of Scottish Justice; The Morning after Flodden; A Wappenshaw; two series of drawings illustrating The Cotter's Saturday Night and The Soldier's Return, John Anderson my Jo, Auld Mare Maggie. In 1864 he went to London.

Faed, THOMAS, R.A., younger brother of the preceding, born at the same place in 1826. He studied in Edinburgh, where at an early age he became known as a clever painter of rustic subjects. In 1852 he settled in London, where he won a high reputation. The subjects he has painted are for the most part domestic or pathetic, and in these he has contrived and told his own story, and that with a success that emulates Wilkie. Among his principal works are: Sir Walter Scott and his Friends (1849), The Mitherless Bairn (1855), The First Break in the Family (1857), Sunday in the Backwoods (1859), His Only Pair (1860), From Dawn to Sunset (1861), The Last o' the Clan (1865). A number of Mr. Faed's works have been engraved in large size, and have been very popular.

Faenza (fâ-en'za), an episcopal city of N. Italy, in the province of and 19 miles southwest of Ravenna. It is supposed to have been the first Italian city in which earthenware was introduced; hence *Faience* (which see). The manufacture still flourishes here, and there is also a considerable trade in spinning and weaving silk. Pop. 13,998.

Fagging, a custom which formerly prevailed generally at most of the English schools, and is still practised at Eton, Winchester, Harrow, Rugby, and one or two other places. It consists in making the junior boys act as servants or 'fags' in the performance of multifarious menial offices for the elder boys, such as carrying messages, preparing breakfast, &c., for their master, in return for which the elder boy accepts a certain responsibility for keeping order, and becomes the recognized adviser and protector of his 'fags.'

Faggot-vote, a name in Britain for a vote procured by the purchase of property so as to constitute a nominal qualification without a substantial basis. Faggot-votes are chiefly used in county elections for members of parliament. The way in which they are usually manufactured is by the purchase of a property which is divided into as many lots as will constitute separate votes, and

given to different persons, who may not be resident members of the constituency.

Fagot'to, the Italian name of the bassoon (which see).

Fahlerz (fâl'erts), or gray copper ore, is of a steel-gray or iron-black colour. It occurs crystallized in the form of the tetrahedron, also massive and disseminated. Its fracture is uneven or imperfectly conchoidal. Specific gravity 4.5. It consists of from 30 to 40 per cent of copper with iron and sulphur; but it also contains in very variable proportions zinc, lead, antimony, and silver.

Fahlunite. See *Falunite*.

Fahrenheit (fâ'rèn-hīt), GABRIEL DANIEL, German physicist, known for his arrangement of the thermometer, was born at Dantzic in 1686. Abandoning the commercial profession for which he had been designed, he settled in Holland to study natural philosophy. In 1720 he effected a great improvement by the use of quicksilver instead of spirits of wine in thermometers. He invented the Fahrenheit scale (see *Thermometer*), and made several valuable discoveries in physics. He died in 1736.

Faidherbe (fâ-derb), LOUIS LÉON CÉSAR, a French general, born in 1818, entered the army in 1840, served in Africa and the West Indies, was appointed governor of Senegal in 1854, and afterwards of a district in Algiers from 1867 to 1870. After the fall of Napoleon III. he was summoned by the government of the National Defence to France and appointed commander of the army of the north. He fought some bloody but indecisive battles with the Germans under Manteuffel and Goeben. After the war he was elected to the Assembly by Lille, his native place, but on the triumph of Thiers retired from politics to private life. He has written some valuable monographs on Senegal, the Soudan, and other parts of Africa.

Faience (fâ-yens'), imitation porcelain, a kind of fine pottery, superior to the common pottery in its glazing, beauty of form, and richness of painting, and of which several kinds are distinguished by critics. It derived its name from the town of Faenza, in Italy, where a fine sort of pottery called *majolica* was manufactured as early as the 14th century. The *majolica* reached its greatest perfection between 1530 and 1560. In the Louvre, at Berlin, and at Dresden are rich collections of it. The modern faience appears to have been invented about the middle of the 16th century, at Faenza,

as an imitation of majolica, and obtained its name in France, where a man from Faenza, having discovered a similar kind of clay at Nevers, had introduced the manufacture of it. True faience is made of a yellowish or ruddy earth, covered with an enamel which is usually white, but may be coloured. This enamel is a glass rendered opaque by oxide of tin or other suitable material, and is intended not only to glaze the body, but to conceal it entirely. See *Pottery*.

Faily (fâ-yē), PIERRE LOUIS CHARLES ACHILLE DE, French general, born in 1810. He distinguished himself in the Crimean war, and commanded a division against the Austrians in 1859. He was the means of introducing the Chassepot rifle into the French army, and commanded the troops which dispersed Garibaldi's irregulars at Mentana. At the outbreak of the Franco-German war Faily received the command of the Fifth Corps, but was severely criticised by his countrymen for the unskillfulness of his operations during the war. He died Nov. 15, 1892.

Fainéants (fā-nā-än; Fr. 'do-nothings'), a sarcastic epithet applied to the later Merovingian kings of France, who were puppets in the hands of the mayors of the palace. Louis V., the last of the Carolingian dynasty, received the same designation.

Fainting, or syncope, a sudden suspension of the heart's action, of sensation, and the power of motion. It may be produced by loss of blood, pain, emotional disturbance, or organic or other diseases of the heart. It is to be treated by placing the patient on his back in a recumbent position or even with head slightly depressed, sprinkling cold water on his face, applying stimulant scents to the nostrils, or anything which tends to bring back the blood to the brain. The admission of fresh cool air and the loosening of any tight articles of dress are important.

Fairbairn, PATRICK, Scottish theologian, born 1805, died 1874. He became a minister of the Established Church, but joined the Free Church at the disruption in 1843. In 1853 he was appointed professor of divinity in the Free Church College, Aberdeen, and in 1856 principal of the Free Church College, Glasgow. Among his works are: *Typology of Scripture*; *Jonah, his Life, Character, and Mission*; *Ezekiel*; *Prophecy*; *Hermeneutical Manual*; *Pastoral Epistles of St. Paul*. He edited and wrote extensively for the *Imperial Bible Dictionary*.

Fairbairn, SIR WILLIAM, British civil engineer, born at Kelson, Roxburghshire in 1789. He was apprenticed as an engine-wright at a colliery in North Shields, and commenced business on his own account in Manchester with a Mr. Lillie in 1817, where he made many improvements in machinery, such as the use of iron instead of wood in the shafting of cotton-mills. About 1831, his attention having been attracted to the use of iron as a material for ship-building, he built the first iron ship. His firm became extensively employed in iron ship-building at Manchester and at Millwall, London, and had a great share in the development of the trade. He shares with Mr. Stephenson the merit of constructing the great tubular bridge across the Menai Strait. Fairbairn was one of the earliest members of the British Association for the Advancement of Science, of which he was president in 1861-62. He was created a baronet in 1869. He died 18th August, 1874. Sir William wrote many valuable professional books and papers, amongst which we may mention: *On Canal Steam Navigation* (1831); *Iron—its History, Properties, and Manufacture* (1841); *Application of Iron to Building Purposes* (1854); *Iron Ship-building* (1865). His brother SIR PETER, born 1799, died 1861, was also a mechanical genius, and had large machine-works at Leeds.

Fairfax, EDWARD, the translator into English verse of Tasso's *Jerusalem Delivered*, was the natural son of Sir Thomas Fairfax of Denton, and born in the last quarter of the 16th century. He settled at Newhall in the parish of Fuyistone, Yorkshire, to a life of studious leisure. The first edition of his translation bears the date of 1600. One or two eclogues by him also remain. He died in 1635.

Fairfax, THOMAS, LORD, a distinguished commander and leading character in the civil wars which distracted England in the 17th century. He was born in 1611, at Denton, in Yorkshire, being son and heir of Ferdinando, Lord Fairfax, to whose title and estates he succeeded in 1648. After serving in the Netherlands with some reputation he returned to England, and on the rupture between Charles I. and the parliament joined the forces of the latter. In 1642 he was appointed general of the horse, and two years later held a chief command in the army sent to co-operate with the Scots. In 1645, on the resignation of the

Earl of Essex, Fairfax became general-in-chief of the parliamentary army. After the victory at Naseby he marched into the western counties, quelling all opposition, put down the insurgents in Kent and Essex in 1647, and captured Colchester. In April, 1649, he was occupied along with Cromwell in suppressing revolt in the army; but positively declined to march against the Scottish Presbyterians. He was a member of Cromwell's first parliament. He co-operated in the restoration of Charles II., being one of the committee charged to secure his return. He died at Nun Appleton, Yorkshire, 12th November, 1671.

Fair Head, a basaltic promontory on the north coast of Ireland, co. Antrim, rising to the height of 636 ft.

Fairies, **ELVES**, &c., imaginary supernatural beings or spirits supposed to have considerable influence for good or evil in the affairs of men. The name *fairy* comes ultimately from the Latin *fatum*, fate. In the 12th century the poem of Lancelot of the Lake introduced the poetical treatment of the fairy world into France; and the fairies played an important part in the romantic works of the time. In the last part of the 17th century the true fairy tales first became popular, the Italians taking the lead in the *Pentameron* of Basilio. The fashion passed to France, where Perrault in 1697 published *Contes de ma Mère l'Oye*. Numerous imitations soon appeared. The best collections of later times have been the *Cabinet des Fées* (Paris and Geneva 1786, thirty-seven vols.); those of the Brothers Grimm in German, and in English those of Keightley and Croker. As an original writer of fairy tales, Hans Christian Andersen, the celebrated Dane, deserves particular mention.

Fair Isle, an island lying nearly midway between the Orkney and Shetland islands, 3 miles long by 2 broad. It is inaccessible except at one point, and rises to the height of 480 ft. Some grain is grown, but the surface is better suited for sheep pasture. The men employ themselves in fishing, and the women knit a well-known variety of hosiery, an art which, it is said, the Spaniards introduced who escaped from the wreck of one of the vessels belonging to the Spanish Armada. Pop. 214.

Fair Oaks, **BATTLE OF**, fought at Fair Oaks in Virginia, 7 miles E. of Richmond, between the Confederates under Gen. Johnston and the Union troops under Gen. McClellan, 31st May, 1862. The loss on

each side was nearly 6000 men; the result was indecisive.

Fairs, periodical meetings of persons having goods or wares for sale in an open market held at a particular place, and generally for the transaction of a particular class of business. The origin of fairs is obviously to be traced to the convenience of bringing together at stated times the buyers and sellers of the stock-produce of a district. In Europe the numerous festivals of the church afforded the most favourable opportunity for the establishment of these markets. This association is indicated in the German name of a fair, which is identical with that used for the ceremony of the mass. In the middle ages fairs were of great importance, and were specially privileged and chartered by princes and magistrates, public proclamation being made of their commencement and duration. But modern facilities of communication have much diminished the necessity for periodical markets, and it is now chiefly amongst agriculturists that they are of much importance, large agricultural meetings being held in various districts for the sale of cattle and horses, and for the exhibition of agricultural implements. There are also, especially in Scotland, a considerable number of hiring fairs for farm-servants. In the less developed commerce of the East, however, they still retain much of their ancient importance and magnitude. In Europe the most important fairs of the present day are those at Leipzig and Frankfurt-on-the-Main in Germany, at Lyons in France, and at Nijni-Novgorod in Russia. The latter is, indeed, the largest fair in the world. The fairs of Great Britain now mostly consist of the weekly market-days of country towns and the agricultural meetings already mentioned. In many places the old fair-days are still kept, but are now merely an assemblage of penny-theatres, peep-shows, and such amusements. In the United States there are no fairs of the kind so common in the old world; the term is applied to a variety of exhibitions, especially of cattle and agricultural products; it also includes exhibitions and sales for religious and charitable purposes; likewise the fairs of the American Institute of New York, the Franklin Institute of Philadelphia, the Maryland Institute, and of many other organizations.

Fair Trade, an economical policy advocated by many in Britain, which, while not opposed to free-trade in principle, would

meet the prohibitory tariffs that foreign countries may put on British goods by placing equally heavy duties on goods sent from these countries to Britain. See *Free-trade*.

Fairweather, MOUNT, on the west coast of North America, in Alaska territory. It rises to the height of 14,900 feet, and is covered with perpetual snow.

Fairy Rings, a name given in Britain to rings often seen in fields, &c., formerly supposed to be traced by the fairies in their dances. There are two kinds—one of 6 or 7 yards in diameter, consisting of a bare ring or path, about a foot broad, with green grass in the middle of it; another of smaller dimensions, formed by a circle of grass, greener and fresher than that in the middle. They are ascribed to a kind of fungus.

Faith, the assent of the mind to the truth of what is declared by another, resting on his authority and veracity, either without other evidence or on probable evidence of any kind. In a special sense the term faith is used for the assent of the mind to what is given forth as a revelation of man's relation to God and the infinite, *i.e.* a religious faith; and in Christian theology we have (1st) *historical or speculative faith*, or belief in the historic truthfulness of the Scripture narrative and the claims of Scripture to an inspired and supernatural origin: (2d) *Evangelical or saving faith*, that emotion of the mind (as Dwight defines it) which is called trust, or confidence exercised towards the moral character of God, and particularly of the Saviour.

Faith, CONFESSION OF. See *Confession of Faith*.

Faizabad (fī-zä-bäd'). See *Fyzabad*.

Fakirs (fä-kērz'; lit. 'poor men'), a kind of fanatics met with chiefly in India and the neighbouring countries, who retire from the world and give themselves up to contemplation. They are properly of the Mohammedan religion, but the term is often used for a mendicant of any faith. They are found both living in communities and solitary. The wandering fakirs gain the veneration of the lower classes by absurd penances and self-mutilations.

Falaise (fä-lāz), a town, France, dep. Calvados, picturesquely situated on a rocky precipice (Fr. *falaise*) 23 miles s.s.e. of Caen. It contains several objects of interest, among others the ruined castle of the dukes of Normandy, where William the Conqueror was born. Pop. 7849.

Falashas. See *Abyssinia*.

Falckenstein, EDWARD VOGEL VON, a Prussian general, born in 1797. In 1813 he entered the Prussian army, distinguishing himself at the battles of Katzbach and Montmirail. In 1848 he served in the Holstein campaign, and he acted as colonel and chief of staff in the war with Denmark in 1864. In the war of 1866 he commanded the Seventh Army Corps. On the outbreak of the Franco-German war in 1870 he was appointed military governor of the maritime provinces.

Falcon (fä'kn), a name of various birds of prey, members of the family Falconidæ (which see). The falcons proper (genus *Falco*), for strength, symmetry, and powers



Peregrine Falcon (*Falco peregrinus*).

of flight are the most perfectly developed of the feathered race. They are distinguished by having the beak curved from the base, hooked at the point, the upper mandible with a notch or tooth on its cutting edge on either side, wings long and powerful, the second feather rather the longest, legs short and strong. The largest European falcons are the jerrfalcon or gyrfalcon proper (*Falco gyrfalco*), a native of the Scandinavian Peninsula, and the Iceland falcon (*F. Islandus*); to which may be also added the Greenland falcon (*F. Groenlandicus* or *candicans*). Between these three species much confusion at one time prevailed, but they are now distinctly defined and described. In the Greenland falcon the prevailing colour at all ages is white, in the Iceland falcon dark. The latter more nearly resembles the true gyrfalcon of Norway, which, however, is generally darker, rather smaller, but with a longer tail. The average length

of any of these falcons is about 2 feet. The Greenland species used to be the most highly prized by falconers. Its food consists chiefly of ptarmigans, hares, and water-fowl. It is found over a wide range of northern territory. The peregrine falcon (*F. peregrinus*) is not so large as the jerrfalcon, but more elegant in shape. It chiefly inhabits wild districts, and nestles among rocks. It preys on grouse, partridges, ptarmigans, pigeons, rabbits, &c. Its flight is exceedingly swift, said to be as much as 150 miles an hour. The peregrine falcon was one of those most frequently used in falconry. Other British falcons are the hobby (*F. subbuteo*), formerly a great favourite for the chase of small game when falconry was in fashion; the merlin (*F. aesalon*), small but swift and spirited; the kestrel (*F. tinnunculus*), one of the most common British falcons. The term falcon is by sportsmen restricted to the female, the male, which is smaller and less courageous, being called *tiercel*, *tersel*, *tercelet*, or *falconet*. See *Falconry*.

Falco'ne, ANCELLO, Italian painter, born in 1600, studied along with Salvator Rosa under Spagnoletto. His paintings, consisting chiefly of battle-pieces, are highly esteemed, but very rare. He died in 1665.

Falconer (fak'nér), HUGH, Scottish naturalist, born in 1808. After studying arts at Aberdeen and medicine at Edinburgh he went to India as a surgeon in 1830. Here he made valuable geological researches, and turned his attention to the introduction of tea cultivation. In 1837 he accompanied Barnes' second mission to Cabul. He visited England in 1843 and published an illustrated descriptive work entitled *Fauna Antiqua Sivalensis* (Ancient Fauna of the Siválik Hills). He returned to India in 1848, where he had been appointed superintendent of the botanic garden at Calcutta. In 1855 he returned to England, where he died 31st January, 1865.

Falconer, WILLIAM, poet and writer on naval affairs, born at Edinburgh in 1732. He went to sea in the merchant service, was wrecked, and wrote a poem (*The Shipwreck*) descriptive of the incidents, published in 1762. He now entered the navy, and was rated as midshipman on board the *Royal George*. In 1769 he published a *Universal Marine Dictionary*. The same year he sailed for Bengal as purser of the *Aurora* frigate, which is believed to have foundered at sea.

Falcon'idæ, a family of birds of prey, in

which the destructive powers are most perfectly developed. The family includes the different species of eagles as well as the hawks and falcons properly so called, comprising the sub-families Buteoninæ (buzzards), Polyborinæ (caracaras), Aquilinæ (eagles), Falconinæ (falcons), Milvinæ (kites), Accipitrinæ (hawks), and Circinæ (harriers).

Falconry (fa'kn-ri), the pursuit of game by means of trained falcons or hawks; also called *Hawking*. Falconry is a very old amusement in Europe and Asia. In the middle ages it was the favourite sport of princes and nobles; and, as ladies could en-



Goshawk hooded for Falconry

gage in it, it became very prevalent. Charlemagne passed laws in regard to falconry. In Germany Henry the Fowler and the Emperor Frederick the Second were much addicted to this sport, the latter having written a work on falconry. In France it reached its height under Francis I., whose grand falconer had under him an establishment of 15 nobles and 50 falconers, costing annually about 40,000 livres. In Britain it was practised among the Anglo-Saxons, but grew still more in favour after the Norman Conquest. One of the most interesting English works on the subject is that which forms the first part of the *Boke of St. Albans*, first printed in 1481. In England the Duke of St. Albans is still hereditary grand falconer, and presents the king with a cast (or pair) of falcons on the day of his coronation. Falconry continued in favour till the 17th century; but the invention of fire-arms gradually superseded it, though in isolated instances gentlemen may still be found who pursue the sport to some little extent. In

FALDSTOOL — FALKLAND ISLANDS.

Persia and other eastern countries hawking is still in great favour. The training of a hawk is a matter requiring great pains and protracted attention, the natural wildness and intractableness of the birds being difficult to overcome. When a hawk suffers itself to be hooded and unhooded quietly and will leap on the hand of the trainer to receive food, its education is considered far advanced, and the trainer now endeavours to accustom it to the *lure*. This may be a piece of leather or wood covered with the wings and feathers of a bird and attached to a cord. The falcon is fed from it, and is recalled by the falconer swinging the lure round his head with an accompanying cry. When it has been taught to obey the lure it is then practised in the mode of seizing its game, which is first done with tame game attached to a peg. It is then made to fly at free game, and when it is fully trained it is used for sport. It is always kept hooded during excursions, until it is wanted to fly.

Fald'stool, a folding stool provided with a cushion for a person to kneel on during the performance of certain acts of devotion, especially a kind of stool placed at the south side of the altar, on which the kings of England kneel at their coronation. The term is also given to a small desk at which the litany is enjoined to be sung or said.

Faler'nian Wine, an ancient wine of great repute amongst the Romans. It was made from the grapes grown on Mount Falernus in Campania. It was strong and generous, probably much resembling modern sherry.

Falie'ri, MARINO, Doge of Venice, born in 1274, commanded the troops of the republic at the siege of Zara in Dalmatia, where he gained a brilliant victory over the King of Hungary. He succeeded Andrea Dandolo, 11th October, 1354, was accused of a design to overthrow the republic and make himself sovereign of the state, and beheaded 17th April, 1355. The last scenes of his life are depicted in Byron's tragedy of Marino Falieri.

Falk'kirk, a parliamentary burgh of Scotland, in Stirlingshire, 21½ miles west by north of Edinburgh. The older portion of it is old-fashioned and irregularly built. There are several modern suburbs. In the town or its vicinity are the Carron Iron-works, the Falkirk Foundry, and other works, collieries, chemical works, distilleries, &c. Falkirk is connected with the port of Grangemouth by a railway 3 miles long.

The Trysts of Falkirk, held on Stenhouse-muir, 3 miles to the N.N.W., are the largest cattle-fairs in Scotland. Falkirk is of great antiquity, and is associated with many remarkable historical events. In the neighbourhood was fought the Battle of Falkirk in 1297 between Sir William Wallace and Edward I., the Scots, who were much inferior in numbers, being defeated. About 1 mile south-west from the town the Highlanders under Prince Charles defeated the royal forces under General Hawley, Jan. 17, 1746. The *Falkirk Burghs*, consisting of Falkirk, Lanark, Hamilton, Airdrie, and Linlithgow, return one member to the House of Commons. Pop. of Falkirk, 16,615.

Falkland (fak'land), an ancient royal burgh of Scotland, county of Fife, 21 miles north of Edinburgh. It was once the residence of the Scottish kings, and possesses remains of an ancient palace and some curious old houses. There was formerly a castle here, in which David, eldest son of Robert III., was starved to death by order of his uncle the Duke of Albany, but no trace of it now remains. Pop. 972.

Falkland (fak'land), LUCIUS CARY, VISCOUNT, an English worthy, born about 1610. His father being then Lord-deputy of Ireland, he was educated at Trinity College, Dublin. After passing a short time abroad he devoted himself to a life of retirement and the cultivation of polite literature, chiefly residing at his seat at Burford, near Oxford, which he made a kind of academy for the learned men of the neighbouring universities. In 1639 he joined the expedition against Scotland; and in 1640, his peerage being Scottish, he was chosen member of the House of Commons for Newport, in the Isle of Wight. In the first instance he warmly supported the parliament, but doubts of the ultimate objects of the parliamentary leaders caused him to modify his attitude; and in 1642 he accepted from Charles I. the office of secretary of state. When hostilities began he embraced decidedly the cause of the king, though he wished rather peace than victory. He was slain at the battle of Newbury, 20th Sept. 1643. He left behind him several pamphlets and published speeches, also a few poems, but nothing that explains the universal praises bestowed on him by contemporaries.

Falkland Islands, an island group belonging to Great Britain, in the South Atlantic Ocean, about 300 miles east of the Straits

of Magellan. They consist of two larger islands, East Falkland and West Falkland, containing respectively about 3000 and 2300 square miles, with a great number of smaller ones surrounding them; total area, 6500 sq. miles. They are hilly and boggy, entirely destitute of trees, but covered with a variety of grasses very nutritive for the sheep and cattle, the rearing of which is the principal industry. Fish and sea-fowl abound. Wool, frozen meat, hides, and tallow are the chief exports; total value in 1891, £130,752. The climate is equable and very healthy. The Falkland Islands were discovered by Davis on the 14th August, 1592. In 1710 a French vessel from St. Malo touched at them, and named them Isles Malouines. Settlements were afterwards formed on them by the French, Spaniards, and English alternately, but the latter have ultimately retained possession of them. The colony has a governor and other officers appointed by the crown. Port Stanley, in East Falkland, is a thriving settlement. Pop. of the group, 1800.

Fal'lacy, in logic, is when an argument is used as decisive of a particular issue, which in reality it does not decide. Properly a fallacy is a fault in the form of reasoning (see *Logic*), but the term is applied also to faults in the substance of the argument such as the *petitio principii*, or proving one proposition by assuming another which is identical with it; *ignoratio elenchi*, or mistaking the point at issue; *post hoc ergo propter hoc*, or arguing as if sequence were the same thing as cause and effect.

Falling-sickness. See *Epilepsy*.

Falling Stars. See *Meteors*.

Fall of Bodies. All bodies on the earth, by virtue of the attraction of gravitation, tend to the centre of the earth. A ball held in the hand presses downward; if dropped, it descends perpendicularly; if placed on an inclined plane, it rolls down, in doing which it presses the plane with a part of its weight. In the air bodies fall with unequal velocities, a piece of paper, for instance, more slowly than a ball of lead; and it was formerly thought that the velocity of the fall of bodies was in proportion to their weight. This error was attacked by Galileo, who, experimenting with balls of different substances which he dropped from the tower of Pisa, was led to the conclusion that the resistance of the air acting on different extents of surface was the cause of the unequal velocities, and that in a vacuum all bodies would fall with the same velocity. The

truth of this last proposition was first demonstrated by Newton in his celebrated 'guinea-and-feather' experiment, where a guinea and feather are shown to fall side by side in the vacuum of the air-pump. This experiment proves that the force of gravitation in bodies is proportional to their inertia, that is to their mass. The laws of falling bodies, that is of bodies falling freely in a straight line and through a distance short in comparison with the earth's centre, are the following:—

1. When a body falls from rest it acquires velocity at the rate of about 32·2 feet per second. This number, which represents the acceleration due to the force of gravity, varies slightly with the locality, increasing from the equator to the poles, and diminishing as we recede from the centre of the earth. (See *Gravity, Force of*.) At the end of five seconds, therefore, the body would be found to be moving at the rate of $5 \times 32\cdot2$, that is 161 feet per second.

2. The space fallen through in the first second is half of 32·2, that is 16·1 feet; and the space fallen through in any given time is found by multiplying the square of the number of seconds by 16·1. Thus, in three seconds a body falls $9 \times 16\cdot1$ feet, or 144·9 feet.

3. The square of the velocity acquired by falling through any number of feet is found by multiplying twice that number by 32·2. Thus if a body falls 9 feet, the square of the velocity acquired is $2 \times 32 \times 9$, or 576 feet per second, 32 being used instead of 32·2; and taking the square root of 576, we find that a velocity of 24 feet is acquired in a fall of 9 feet.

4. When a body is projected vertically upward with a given velocity, it continues to rise during a number of seconds found by dividing the number that expresses the velocity of projection by 32·2; and it rises to a height found by dividing the square of that number by $2 \times 32\cdot2$, or 64·4. For a machine used in verifying the laws of falling bodies see *Attwood*.

Fall of Man, a commonly received doctrine of Christianity, founded upon the historical narrative contained in the third chapter of the book of Genesis, together with the allusions to the same matter in other parts of Scripture. Adam, having eaten of the forbidden fruit, is said to have fallen; and the relation of mankind in general to this fall is stated by St. Paul in the words: 'By one man's disobedience many

were made sinners' (Rom. v. 19). Thus, in the fall of Adam, all men are held to have fallen and to have contracted 'original sin,' alienating them from God and rendering them morally inadequate. The doctrine of the fall does not stand alone in Scripture. It is universally agreed by interpreters that in the original sentence pronounced on the transgressors there is contained the promise of a redemption, and that the whole scope of Scripture is directed to the development of this promise, and of the divine scheme of providence associated with it.

Fallopian Tubes, in anatomy, are two ducts which open by one extremity into the womb, one at either angle of the fundus, and terminate at the other end in an open trumpet-shaped mouth, which at certain times grasps the ovary and receives the ovum. They are named after Fallopius or Falloppio, an Italian anatomist of the 16th century, who first recognized their functions.

Fallow Deer, a European and Western Asiatic deer, the *Cervus dama*. It is smaller than the stag, of a brownish-bay colour, whitish beneath, on the insides of the limbs, and beneath the tail. The horns, which are peculiar to the male, are very different from those of the stag; they are not properly branched, but are broader towards the upper part, and divided into processes down the outside. A simple snag rises from the base of each, and a similar one at some distance from the first. It was introduced at an early period into Britain, and is kept in many English parks.

Fallow Land is ground that has been left uncultivated for a time, in order that it may recover itself from an exhausted state. Strictly speaking, fallow ground is left altogether without crops; but in agricultural usage strict fallow is not always adopted, and the term fallow is applied to various modes of treatment, of which at least three distinct varieties are recognized: *bare fallow*, *bastard fallow*, and *green-crop fallow*. Bare fallow is that in which the land remains completely bare for a whole year; in bastard fallow it is ploughed up and worked after the removal of a spring or summer crop, preparatory to the sowing of a root or forage crop, to occupy the ground during autumn or winter; in green-crop fallow the land is sown with a root-crop, such as turnips or potatoes, placed in rows far enough apart to admit of the intermediate spaces being stirred, pulverized, and cleaned, during its growth, by horse or hand implements.

Fall River, a city and port, Bristol county, Massachusetts, United States, on an arm of Narraganset Bay and Taunton River, 53 miles s.s.w. of Boston. It is at the head of deep-water navigation, and the terminus of a line of steamers from New York. It contains several handsome streets, and has extensive cotton, woollen, and calico-printing factories, iron-works, &c. Pop. 1890, 74,398.

Falmouth, a seaport and parliamentary and municipal borough of England, in Cornwall, 250 miles w.s.w. of London. There is a good harbour here, with a fine roadstead affording excellent refuge for shipping. Falmouth was at one time an important packet station, but is now chiefly a port of call, its principal trade being in supplies and stores for shipping. Falmouth and Penryn together return a member to parliament. Pop. 4373.

False Bay, a bay of the Cape Colony, having the Cape of Good Hope at its entrance. See *Cape of Good Hope*.

False Imprisonment, the unlawful imprisonment or detention of any person. Every confinement of the person is imprisonment, whether in a common prison or a private house, or even by forcibly detaining one in the streets or highways. The law punishes false imprisonment as a crime, besides giving reparation to the party injured, through an action of trespass.

False Personation (Law). All forms of false personation, for the purpose of obtaining the property of others, are punishable by the criminal law; as instances, the personation of the owner of any share, stock, or annuity, &c.; the false personation of voters at an election is a misdemeanour, the punishment of which is determined by State statute, involving fine, imprisonment, and deprivation of the rights of citizenship for a certain period.

False Pretences (Law). False representations and statements, made with a fraudulent design to obtain "money, goods, wares, and merchandise," with intent to cheat. At common law a misdemeanour, punishable by statute.

False Prophecies, with intent to disturb the peace, are misdemeanours at common law.

False Signals. To exhibit a false signal, with a view to bring a ship into danger, is a felony, punishable by statute.

Falset'to (Ital.) applies, in singing, to the notes above the natural compass of the voice.

It is also called the *head* or *throat* voice, in contradistinction to the *chest* voice, which is the natural one. The falsetto voice is produced by tightening the ligaments of the glottis.

False Weights and Measures. The using of false weights and measures is an offence at law punishable by fine. By various British statutes standards are provided for weights and for measures of capacity or dimension, and all contracts of sale, &c., are referred to such standards unless there is a special agreement to the contrary. See *Weights and Measures*.

Fal'ster, an island belonging to Denmark, situated at the entrance of the Baltic, east of Laaland, from which it is separated only by a narrow strait; flat, well watered and wooded; productive in grain, pulse, potatoes, and, above all, fruit; area, 183 square miles. The principal town is Nykjöbing, Pop. 30,212.

Falun, or FAHLUN (fä'lun), a town of Sweden, on Lake Runn, 130 miles north-west of Stockholm. It has an excellent mining-school, museums, mineralogical collections, &c. Within the town boundary is the famous Falun copper-mine, formerly the richest in Sweden, and worked for 500 years. Pop. 7413.

Falunite, a mineral of a greenish colour, occurring in six-sided prisms. Its chief constituent is hydrated silicate of alumina. It takes its name from Fahlun or Falun in Sweden.

Fama Clamo'sa ('a clamant report'), in the ecclesiastical law of Scotland, is a public report imputing immoral conduct to a clergyman, licentiate, or office-bearer of the church. When the fama has become so notorious that it cannot be overlooked, the presbytery, after due inquiry, and if no particular party comes forward to institute a process, usually appear as accusers themselves.

Famagos'ta, or FAMAGUSTA, a seaport on the east coast of Cyprus. It is of remote antiquity, was an important place during the middle ages under the Lusignan kings of Cyprus and the Venetians, but, after being captured by the Turks in 1571, it declined. It has improved, however, in late years, since it came into the hands of the British.

Famati'na, a district and mountain range in the Argentine Republic, province of La Rioja, rich in copper; highest summit, the Nevada de Famatina, 19,758 feet high.

Familiar Spirits, demons or evil spirits

supposed to be continually within call and at the service of their masters, sometimes under an assumed shape, sometimes attached to a magical ring, or the like, sometimes compelled by magic skill, and sometimes doing voluntary service. We find traces of this belief in all ages and countries, under various forms.

Family, in zoological classifications, a group of individuals more comprehensive than a genus and less so than an order, a family usually containing a number of genera, while an order contains so many families. Family names usually terminate in -*idæ* (after Latin patronymics, such as *Æacídæ*, sons or descendants of *Æacus*). In botany it is sometimes used as a synonym of order.

Family Compact, the name given to a compact organized by the Duke de Choiseul, first minister of Louis XV., between the various members of the Bourbon family, then sovereigns of France, Spain, the Two Sicilies, Parma, and Piacenza, mutually to guarantee each other's possessions. It was signed 15th August, 1761, and entailed on Spain a war with England.

Famine, a dire want of food affecting considerable numbers of people at the same time. Irregular rainfalls in tropical climates, imperfect methods of irrigation, or, as in Ireland, the too exclusive dependence of the mass of the people on a single article of food which happens to fail, are amongst the commonest causes of famines. In the early and mediæval ages they were frequent; but the rapidity of modern communication and transport has made the rigour of famine almost impossible in Europe. In Ireland the years 1814, 1816, 1822, 1831, 1846, were marked by failure of the potato crop, and in the last-mentioned year the dearth was so great that ten millions were voted by parliament for relief of the sufferers. India has long been the seat of terrific famines; but of late the British officials have been very successful in organizing relief measures. Amongst the more recent are that in North-west India (1837-38), in which above 800,000 perished; that in Bengal and Orissa (1865-66), when about a million perished; that in Bengal (1874), which was very successfully treated; that in Bombay, Madras, Mysore (1877), in which about half a million died. In China a great famine took place in 1877-78, in which over nine millions are said to have perished; another took place in 1888-89 owing to the overflow of the Yellow River.

Fan, the name of various instruments for exciting a current of air by the agitation of a broad surface. (1) An instrument made of wood or ivory, feathers, thin skin, paper, variously constructed and mounted, and used by ladies to agitate the air and cool the face. As an article of luxury the fan was well known to the Greeks and Romans. They are said to have been introduced into England from Italy in the reign of Henry VIII. (2) Any contrivance of vanes or flat discs revolving by the aid of machinery, as for winnowing grain, for cooling fluids, urging combustion, assisting ventilation, &c., is also so called.

Fanar'iot, or PHANARIOTS, the inhabitants of the Greek quarter, or Phanar, in Constantinople, particularly the noble Greek families resident there since the times of the Byzantine emperors. The dragoman or interpreter of the Porte and other high officials used to be taken from their number. They have now mostly lost their influence at Constantinople, and have in many cases transferred themselves to Athens.

Fanat'icism is the term applied more particularly to the extravagance manifested in religious matters by those who allow themselves to be hurried away by their fancy and feelings, to the adoption not only of wild enthusiastic views, but also of inordinate and not unfrequently persecuting measures. By an extension of the term it is also sometimes applied to other forms of extravagance.

Fancy, a term approaching imagination in meaning. In its general acceptation it refers both to the forms of the imagination and to the mental faculty which produces them; but it is used frequently for the lighter or more fantastic forms of the imagination, and for the active play of that faculty which produces them. See *Imagination*.

Fancy-goods, fabrics of various patterns; as ribbons, silks, satins, &c. differing from those which are of a plain or simple colour, rather ornamental than solid or useful.

Fandan'go, an old Spanish dance, which originated most probably with the Moors in Andalusia. It is seldom danced but at the theatre, and in the parties of the lower classes. It is danced by two persons only, who never touch so much as each other's hands; their reciprocal allurements, retreats, approaches, and varied movements, by turns pursuing and pursued, their looks, attitudes, and whole expression, are grossly indicative of voluptuousness.

Faneuil Hall (fan'ū-il), a public building in Boston, famous as the place where stirring speeches were made at the outbreak of the war for American independence. It obtained the name "The cradle of American liberty." It was enlarged in 1805.

Fanfare, a short, lively, loud, and warlike piece of music, composed for trumpets and kettle-drums. Also small, lively pieces performed on hunting-horns, in the chase.

Fan-foot, a name given to a North African lizard of the genus *Ptyodactylus* (*P. Gecko*), one of the geckoes, much dreaded in Egypt for its supposed venomous properties.

Fanning Islands, a group of coral islands in Central Polynesia between 1° 57' and 5° 49' N. lat., and between 157° and 162° W. lon. They include Jarvis, Christmas, Washington, Palmyra, and Fanning, and have been occupied by the British. The population is very small.

Fano, a seaport of Italy, on the Adriatic, province of Pesaro e Urbino, 29 miles north-west of Ancona. It is a handsome, well-built town, and has a triumphal arch erected to Augustus, and other antiquities. Pop. 9484.

Fan-palm, a name sometimes given to the talipot palm or *Corijpha umbraculifera*, a native of Ceylon and Malabar. (See *Talipot Palm*.) It is also applied to the Mauritia palm (*Mauritia flexuosa*), a tree which grows in great abundance on the banks of the Orinoco river in South America, and which yields the natives of these regions food, wine (made from its sap), and cordage, besides serving them for housing during the inundations to which the country is subject.

Fans, an African race of people inhabiting the region of the west coast about the Gaboon River and the Ogoway. They are an energetic race, skilled in various arts, and are rapidly increasing in numbers. They are cannibals, but contact with Europeans is leading them to give up the practice.

Fanshaw, SIR RICHARD, an English diplomatist, poet, and translator, born in 1608. He studied at Cambridge; was secretary of the English embassy at Madrid; and took the royal side on the outbreak of the civil war in 1641. He was made a baronet in 1650, was taken prisoner at Worcester, but permitted to go at large on bail. After the restoration he was employed on several diplomatic missions, and in 1664, as ambassador at Madrid, negotiated a peace between England, Spain, and Portugal. He died at Madrid in 1666. His poetical abilities were

above mediocrity, as is evinced by his translations of the *Lusiads* of Camoens, the *Pastor Fido* of Guarini, the *Odes* of Horace, and the fourth book of the *Æneid*.

Fan-tail, a variety of the domestic pigeon, so called from the fan-like shape of their tails. Also a name applied to certain Australian birds of the fly-catcher family.

Fanta'sia, in music, a species of composition in which the author ties himself to no particular theme, ranging as his fancy leads him amidst various airs and movements.

Fantee', a country of Africa, on the Gold Coast, which extends about 90 miles along the shore of the Atlantic and 70 inland. The inhabitants, called *Fantees*, were the most numerous and powerful people situated immediately on the Gold Coast; but their power has been almost entirely broken since 1811 by repeated invasions of the Ashantees, and they have since lived under British protection. The soil is fertile, producing fruits, maize, and palm-wine.

Fan-tracery, in architecture, elaborate geometrical carved work, which spreads

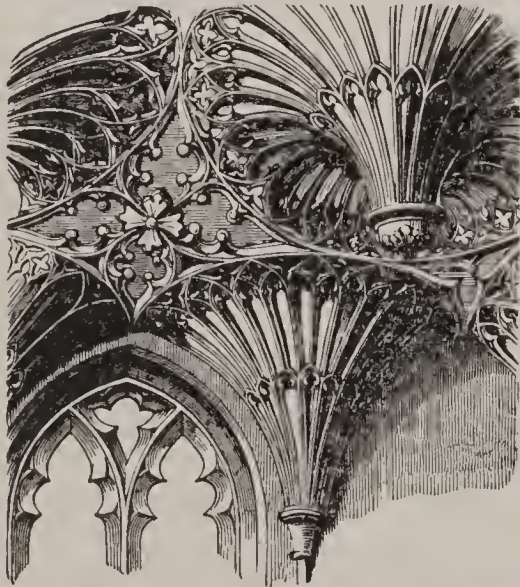

Fan-tracery Vaulting, Beauchamp Chapel, Warwick

over the surface of a vaulting, rising from a corbel and diverging like the folds of a fan. Fan-tracery vaulting is much used in the Perpendicular style, in which the vault is covered by ribs and veins of tracery, of which all the principal lines diverge from a point, as in Henry VII.'s chapel, Westminster.

Far'aday, MICHAEL, one of the greatest of English chemists and physicists, was born in humble circumstances at Newington Butts, near London, on the 22d September, 1791. Early in life he was apprenticed to

a bookbinder in London, but occupied himself in his leisure hours with electrical and other scientific experiments. Having been taken by a friend to Sir Humphry Davy's lectures, he attended the course, and conceived such an ardent desire for study that he resolved to quit trade. With this end he sent his notes of the lectures to Sir Humphry Davy, who was so struck with the great ability they showed that he appointed him his assistant at the Royal Institution. In 1829 he became lecturer at the Royal Military Academy at Woolwich, and in 1833 he was appointed to the newly-established chair of chemistry at the Royal Institution. It was while in this office that he made most of his great electrical discoveries. His communications to the *Philosophical Transactions* have been published separately in three vols. (1839, 1844, 1855). In 1832 he received the honorary degree of D.C.L. from Oxford, was made an honorary member of the Academy at Berlin, with many other honours too numerous to mention. In 1835 he received a pension of £300 a year from Lord Melbourne. He died Aug. 25, 1867. As an experimentalist Faraday was considered the very first of his time. As a popular lecturer he was equally distinguished, and used to draw crowds to the Friday evening lecture at the Royal Institution. Amongst his published works we may mention the following:—*Researches in Electricity* (1831–55), *Lectures on Non-metallic Elements* (1853), *Lectures on the Forces of Matter* (1860), *Lectures on the Chemical History of a Candle* (1861).

Faradization, the medical application of the magneto-electric currents which Faraday discovered in 1837.

Farâf'ra, one of the Egyptian oases in the Libyan desert.

Farallo'nes, a group of small islands in the Pacific, about 30 miles from the entrance to the Bay of San Francisco.

Faran'dola, an exciting dance popular amongst the peasants of the south of France and the neighbouring part of Italy. The men and women, placed alternately and facing different ways, form a long line winding out and in with a waving motion.

Farce, a dramatic piece of low comic character. It is grotesque and extravagant rather than artistically humorous.

Farcy, a disease to which horses are liable, intimately connected with glanders, the two diseases generally running into each other.

It is supposed to be a disease of the absorbents of the skin, and its first indication is generally the appearance of little tumours called farcy buds on the face, neck, or inside of the thigh. By order of council animals affected with farcy must be destroyed.

Fardel-bound, a term applied to cattle and sheep affected with a disease caused by the retention of food in the maniplies or third stomach, between the numerous plaits of which it is firmly impacted. Over-ripe clover, vetches, or rye-grass are liable to produce the disease.

Fareham, a town of England, in Hampshire, at the north-west extremity of Portsmouth harbour, giving name to a parl. div. of the county. It has building-yards, potteries, and brickworks, and a considerable trade. Pop. 7171.

Farel, GUILLAUME, one of the earliest and most active of the Swiss reformers, was born in 1489 in Dauphiny, and at an early period was led by his intercourse with the Waldenses to adopt similar views. After preaching in various parts of Switzerland he came to Geneva, where he was so successful at the religious conferences of 1534 and 1535 that the council formally embraced the Reformation. He was instrumental, also, in persuading Calvin to take up his residence in Geneva. An attempt on the part of the two reformers to enforce too severe ecclesiastical discipline was the cause of their having to leave the city in 1538. Farel took up his residence at Neuchâtel, where he died in 1565.

Farewell, CAPE, a cape at the southern extremity of Greenland.

Fargo, a town of North Dakota, on the Red river of the North and the N. Pacific Railroad. A destructive fire occurred June 7, 1893, causing a loss of over \$3,000,000 and 225 business houses and residences; 2200 persons were made homeless. Pop. 1890, 5664.

Faria y Sousa, MANUEL, Portuguese historian and poet, born 1590, of an ancient and illustrious family, died about 1649.

Faribault, a town of Minnesota, U. States, 53 miles south of St. Paul. Here are the state asylum for the deaf, dumb, and blind, and an episcopal divinity college. Pop. 6524.

Faridpur (*fa-rēd-pōr'*), a district of India, in the Dacca Division of Bengal; area 2267 sq. miles; pop. 1,631,734. Chief town, Faridpur, on the Mará Padmá. Pop. 10,263.

Fari'na, a term given to a soft, tasteless, and commonly white powder, obtained by

trituration of the seeds of cereal and leguminous plants, and of some roots, as the potato. It consists of gluten, starch, and mucilage.

Farinel'li, CARLO, an Italian singer, born at Naples in 1705. His true name was Carlo Broschi, and to develop his vocal powers he was made a eunuch. He sung in Vienna, Paris, and London with the greatest success. On visiting Spain, where he intended only a brief sojourn, he found King Philip V. plunged in a profound melancholy. He succeeded in rousing him from it by the powers of his voice, and became his prime favourite and political adviser. But the penalty of his advancement was that for ten years he had to sing every night to his royal master the same four airs. On his return to Italy, in 1762, he found himself almost forgotten, but continued to exercise a splendid hospitality in his country house, near Bologna. He died in 1782.

Far'ingdon, a market town, England, county of Berks, 16 miles south-west of Oxford. Pop. 5518.

Fari'ni, LUIGI CARLO, an Italian statesman and author, born in 1812. He studied medicine at Bologna, and practised as a physician. He became known as a nationalist and patriot in the political movements of 1841, had to leave the country for a time, but returned and was made a member of the Reform Ministry at Rome during the disturbances of 1848. Disapproving equally the views of the old Conservative and the extreme Republican party, he went to Piedmont, where he was elected a deputy, and fought with great energy both in literature and in parliament on behalf of Cavour and the Piedmontese Constitutionalists. After the peace of Villafranca he was chosen dictator of the duchies of Parma and Modena, and was mainly instrumental in inducing them to unite with the Piedmontese monarchy. His History of the Papal States from 1814 to 1850 is well known. In 1862 he became president of the ministry, lost his reason in 1863, and died 1st Aug. 1866.

Farmers-general (French, *Fermiers généraux*), private contractors, to whom under the old French monarchy was let out the collection of various branches of the revenue, poll-tax, duties on salt and tobacco, customs, &c. These contractors made enormous profits on the farming of the public revenues. A revenue collected in this way not only imposed a much heavier burden on the people, but the merciless rigour of irresponsible and

uncontrolled exactors subjected them to hardships and indignities to which they could not submit without degradation. In 1790 the system was suppressed by the constituent assembly.

Farming. See *Agriculture*.

Farne (or FERNE) **Islands**, a group of islets, England, in the German Ocean, off the north coast of Northumberland, 2 miles E. by S. of Bamborough Castle, and separated from the mainland by a channel of about $1\frac{3}{4}$ mile. They have been the scene of several disastrous shipwrecks.

Farnese (fār-nā'ze), an illustrious family of Italy, whose descent may be traced from about the middle of the 13th century, and which gave to the church and the Republic of Florence many eminent names, amongst which the following may be mentioned: PIETRO FARNESE (died 1363), a general of the Florentines in the war against Pisa; ALESSANDRO, who became Pope as Paul III. (1534-49), and whose gifts to his natural son Pier Luigi of the duchies of Parma and Piacenza laid the foundation of the wealth and greatness of the family; OTTAVIO (1520-85), son and successor of Pier Luigi, spent a long and peaceful reign in promoting the happiness of his subjects. ALESSANDRO (1546-92), elder son of Ottavio, became famous as a most successful general of the Spaniards in the wars with the Netherlands and France. RANUZIO (1569-1622), son of Ottavio, was a gloomy and suspicious tyrant. The line became extinct with Antonio in 1731. The name of the Farnese is associated with several famous buildings and works of art. The *Farnese Palace*, at Rome, was built for Pope Paul III. while he was cardinal, by Sangallo and Michael Angelo. It is now the residence of the dethroned Bourbon dynasty of Naples. Its sculpture gallery was formerly very celebrated, but the best pieces have been removed to Naples, including the following: The *Farnese Bull*, a celebrated ancient sculpture representing the punishment of Dirce, discovered in the 16th century in the Baths of Caracalla at Rome; *Farnese Hercules*, a celebrated ancient statue of Hercules by Glycon, found in the Baths of Caracalla in 1540; *Farnese Flora*, a colossal statue of great merit, found in the Baths of Caracalla; *Farnese Cup*, an antique onyx cup, highly ornamented with figures in relief.

Farnham, a town of England, county of Surrey, 3 miles S.W. of Aldershot; a well-built place. North of the town is Farnham

Castle, the residence of the bishops of Winchester. The staple trade is in hops. Pop. 4530.

Farnworth, a manufacturing township of Lancashire, England, 3 miles from Bolton. Pop. 1891, 23,758.

Faro, a seaport of Portugal, prov. of Algarve, 62 miles S.E. of Cape St. Vincent. It is surrounded by Moorish walls, and has a convenient harbour. Its trade is considerable. Pop. 8361.

Faro, or PHARO, a game of hazard at cards, played chiefly in gambling establishments, and in which the player plays against the bank, represented by a professional faro-banker.

Faro, a promontory forming the north-east point of Sicily at the entrance to the Strait of Messina. The point is strongly fortified, and on it there is a lighthouse 200 years old.

Faroe Islands (fā'rō; Danish *Färöer*, 'Sheep Islands'), a group of islands in the North Atlantic, lying between Iceland and Shetland. They belong to Denmark, and are twenty-five in number, of which seventeen are inhabited. The islands generally present steep and lofty precipices to the sea. Barley is the only cereal that comes to maturity; turnips and potatoes thrive well. There is no wood, but plenty of excellent turf, and also coal. The inhabitants are chiefly engaged in fishing and the rearing of sheep. Thorshavn, in Strömö, the largest island, is the seat of government. Pop. 1890, 12,955.

Farquhar (fār'kār), GEORGE, a comic writer of eminence, was born at Londonderry, in 1678. He tried the stage as an actor at Dublin, but soon left it to write plays for the London theatres. His first production was *Love in a Bottle*, performed at Drury Lane with great success in 1698. The *Constant Couple*, *Sir Harry Wildair*, *The Inconstant*, *The Recruiting Officer*, *The Beaux' Stratagem* (reckoned his masterpiece) followed during the next six years. He died in 1707. Farquhar's wit is genuine, and his characters drawn from nature; but his plays have the licentious taint of the time.

Far'ragut, DAVID GLASGOW, admiral of the United States, was born in 1801, and entered the navy as midshipman at the age of 9½. In 1821 he was promoted to a lieutenancy, and was actively engaged in his profession up till 1851, when he was appointed assistant inspector of ordnance. In

1855 he received a commission as captain. In 1861 he was assigned to go with the expedition against New Orleans, undertaken on the formation of the Confederacy, and sailed in February of the following year. New Orleans surrendered to the combined attack of the land and naval forces on 25th April, and Farragut proceeded to Vicksburg, running past successfully. In consequence of his success at New Orleans he was promoted to the rank of rear-admiral. In 1863 Farragut attempted to pass the batteries at Port Hudson, but was unsuccessful. In August, 1864, he attacked the Confederate fleet in the bay of Mobile, and forced it to surrender, thus making the fall of Mobile merely a question of time. July 25, 1866, he was made admiral, a grade which had not hitherto existed in the United States navy. He died 14th August, 1870.

Farrakhabad. See *Farukhabad*.

Far'rant, RICHARD, one of the earliest English composers of music. Very little is known of his history. He was a gentleman of the chapel royal in 1564, and subsequently organist and choir-master. He is supposed to have died about 1580. His music, which is ecclesiastical, is distinguished by purity, simplicity, tenderness, and elevation. The anthems Call to Remembrance, and Hide not Thou Thy Face, composed by him, are well known and highly esteemed.

Farrar, FREDERIC WILLIAM, THE VEN., D.D., F.R.S., son of a clergyman, born in Bombay, Aug. 7, 1831; graduated at Cambridge 1854, assistant master at Harrow in 1855, master of Marlborough College in 1871, archdeacon of Westminster 1883. He has published several popular theological works and works of fiction, and is known as a popular lecturer. He was Bampton Lecturer in 1885. Among his principal works are: *The Life of Christ* (1874), *Life of St. Paul* (1879), *The Early Days of Christianity* (1882); *Lives of the Fathers* (1889).

Farriery. See *Veterinary Art*.

Farringdon. See *Faringdon*.

Fars, or FARSISTAN, a maritime province in the south-west of Persia, abutting on the Persian Gulf. It is mountainous, but has many rich and well-cultivated districts. The most important products are grain, fruit, wine, oil, cotton, tobacco, silk, cochineal, and attar of roses. The manufactures include woollen, silk, and cotton goods; and in these and other articles an active trade

is carried on, chiefly with Hindustan. Pop. estimated at 1,700,000.

Farsan, two islands on the east side of the Red Sea on the coast of Yemen, called respectively Farsan Kebir and Farsan Segir.

Farthing, the fourth part of a penny; the modern form of the Anglo-Saxon *feorthung*, the fourth part of anything.

Farthingale, or FARDINGALE, an article of ladies' attire worn in the days of Queen Elizabeth, and closely resembling the modern crinoline. It was formed of circles of whalebone hoops, and protruded more at the waist than the modern crinoline.

Farukhabad, or FARRAKHABAD (*far-ak-ä-bäd'*), a city in the North-west Provinces of British India, 2 or 3 miles from the Ganges, a handsome well-built town, with avenues of trees in many of its streets. Pop. 1891, 78,032.

Fasa'no, a town of South Italy, prov. Bari. Pop. 13,941.

Fasces (*fas'sēz*), among the ancient Romans, a bundle of polished rods, in the middle of which was an axe, carried by lictors before the superior magistrates. The number of fasces and lictors varied with the dignity of the magistrate. In the city the axe was laid aside.

Fas'cia (Lat. a bandage), in anatomy signifies a thin tendinous covering which surrounds the muscles of the limbs and binds them in their places.

Fascination, the exercise of an overpowering and paralysing influence upon some animals attributed to certain snakes, corresponding somewhat to the so-called evil-eye among human beings. Squirrels, mice, and the smaller birds are said to be the most subject to this power; but the fact is far from clearly explained, and is not perhaps even sufficiently demonstrated. Most of the accounts agree in describing the animal fascinated as having a painful consciousness of its danger, and the power exercised over it, but to be unable to resist the desire to approach the fascinator. Some have endeavoured to explain this power as the effect of narcotic emanations from the serpent which stupefy the weaker animal. Others regard it as bearing a striking analogy to the mesmeric influence which one human being sometimes has over another.

Fascines (*fa-sēnz'*), in the military art, bundles of boughs or rods from 6 to 18 feet in length and usually 1 foot in diameter, used in raising batteries, strengthening parapets, revetting slopes, &c. The twigs are

drawn tightly together by a cord, and bands are passed round them at the distance of 2 feet from each other. Very long thin ones are called *saucissons* or *battery-sausages*.

Fashion, the prevalent style in dress and usages which society from time to time adopts and imposes by a sort of arbitrary law upon its members. In its less important details the law of fashion varies considerably, and is often little more than a play of caprice. On its better side it is an endeavour to embody in general and recognized forms the best judgment as to what is decorous and of good taste and feeling in the varying and often delicate situations which occur, where large and mixed companies are in the habit of meeting together. English society has a sort of pre-eminence in the respect it shows for the code of fashion, and the importance which it assigns to an acquaintance with etiquette; so much so that in matters of conventional refinement and courtesy the English standard, curiously enough, has come to be recognized as the highest in Europe, and is exercising a notable influence on foreign manners. The circle of fashion is not necessarily coincident with that of gentility. A man may be of noble birth, wealthy, and distinguished without being fashionable.

Fast-and-loose, a cheating game sometimes played at fairs by low sharpers, and also called 'prick the garter.' A belt or strap is doubled and rolled up with the double in the middle of the coils, it is then laid on a board, and the dupe is asked to catch the double with a skewer, when the gambler takes the two ends and looses it or draws it away, so as always to keep the skewer outside the doubled end.

Fasti (L.), among the Romans, registers of various kinds; as, *fasti sacri*, calendars of the year, giving the days for festivals, courts, &c., being a sort of almanac.

Fasting, the partial or total abstinence of mankind and animals from the ordinary requisite supply of aliment, by which it is to be understood that quantity which is adapted to preserve them in a healthy and vigorous condition. It would appear that various warm-blooded animals are capable of sustaining total abstinence much longer than human beings. Cats and dogs have survived for several weeks without nourishment of any kind, but it is probable that few human beings could survive such deprivation for more than a week. The use of water without solid food enables life to be sustained much longer than it could otherwise be.

Fasts, temporary abstentions from food, especially on religious grounds. Abstinence from food, accompanied with signs of humiliation and repentance or grief, is to be found more or less in almost all religions. Among the Jews fasts were numerous, and we find many instances of occasional fasting in the Old Testament. Herodotus says that the Egyptians prepared themselves by fasting for the celebration of the great festival of Isis. So in the Thesmophoria at Athens, and in the rites of Ceres at Rome, it was practised. The Church of Rome distinguishes between days of fasting and of abstinence. The former are: 1, the forty days of Lent; 2, the Ember days, being the Wednesday, Friday, and Saturday of the first week in Lent, of Whitsun week, of the third week in September, and of the third week in Advent; 3, the Wednesdays and Thursdays of the four weeks in Advent; 4, the vigils or eves of Whitsuntide, of the feasts of St. Peter and St. Paul, of the Assumption of the Virgin, of All Saints, and of Christmas day. When any fasting day falls upon Sunday it is observed on the Saturday before. The Greek Church observes four principal fasts: that of Lent, one beginning in the week after Whitsuntide, one for a fortnight before the Assumption, one forty days before Christmas. In the East, however, the strict idea of a fast is more preserved than in the West. The Church of England appoints the following fixed days for fasting and abstinence, between which no difference is made:—1, the forty days of Lent; 2, the Ember days at the four seasons; 3, the three Rogation days before Holy Thursday; 4, every Friday except Christmas day. The church, however, gives no directions concerning fasting.

Fat, an oily concrete substance, a compound of carbon, hydrogen, and oxygen, deposited in the cells of the adipose or cellular membrane of animal bodies. In most parts of the body the fat lies immediately under the skin. Fat is of various degrees of consistence, as in tallow, lard, and oil. It is generally white or yellowish, with little smell or taste. It consists of two substances, stearine and elaine or oleine, the former of which is solid, the latter liquid. These elements are separated by pressing the fat between folds of bibulous paper, which absorbs the liquid or oil. By after-treatment with water the oil is separated from the paper. Fats are insoluble in water. When boiled with caustic alkalies they are

decomposed (saponification), yielding an alkaline salt of the fatty acid (soap) and glycerine. Human fat appears to contain no stearine, but margarine and oleine. It is an excellent packing material in the body, and gives the human frame its smooth rounded contour. Being a bad conductor of heat, it is useful in retaining warmth, but its chief function is that of nutrition.

Fa'talism, the belief in fate, or an unchangeable destiny, to which everything is subject, uninfluenced by reason, and pre-established either by chance or the Creator. Amongst notable historical examples of the belief in fate may be mentioned the old Greek conception of a fate which stood behind the gods themselves as a controlling power; the Mohammedan fatalism, which regards all things great and small as inexorably predetermined, so that no accident is possible; the theological doctrine of predestination amongst Calvinists. See *Predestination*.

Fata Morga'na, a name given to a very striking optical illusion which has been principally remarked in the Strait of Messina, between the coasts of Sicily and Calabria—a variety of mirage (which see). The images of men, houses, towers, palaces, columns, trees, &c., are occasionally seen from the coast, sometimes in the water, and sometimes in the air, or at the surface of the water. The same object has frequently two images, one in the natural and the other in an inverted position. The images of a single object are said to be sometimes considerably multiplied.

Fategarh (*fat-e-gar'*), a town, North-west Provinces of India, 3 miles from Farukhabad, the scene of a massacre of upwards of 200 Europeans during the mutiny of 1857. Pop. 12,435.

Fatehpur (*fat-e-pör'*), Indian town in district of the same name, Allahabad division, North-west Provinces, 50 miles S.E. of Cawnpore. Pop. 21,328. The district has an area of 1639 sq. miles, and a pop. of 683,745.

Fatehpur Sikri, an Indian town, district of Agra, North-west Provinces. It was the favourite residence of the emperor Akbar, who inclosed and fortified it. It now chiefly consists of a vast expanse of magnificent ruins inclosed by a high stone wall some 5 miles in circuit. Pop. 6243.

Fates (in Latin, *Parca*, in Greek, *Moirai*), in Greek and Latin mythology, the inexorable sisters who spin the thread of human life. The appellation *Clotho* (the spinner)

was probably at first common to them all among the Greeks. As they were three in number, and poetry endeavoured to designate them more precisely, *Clotho* became a proper name, as did also *Atropos* and *Lachesis*. *Clotho* means she who spins (the thread of life); *Atropos* signifies unalterable fate; *Lachesis*, lot or chance; so that all three refer to the same subject under different points of view. They know and predict what is yet to happen. *Lachesis* is represented with a spindle, *Clotho* with the thread, and *Atropos* with scissors, with which she cuts it off. We find also in the northern mythology three beautiful virgins, the *Nornen*, who determine the fate of men. Their names are *Urd* (the past), *Varande* (the present), and *Skuld* (the future).

Fatherlasher, a fish of the genus *Cottus* or bull-head (*Cottus bubälis*), from 8 to 10 inches in length. The head is large, and is furnished with several formidable spines. The fish is found on the rocky coasts of Britain, and near Newfoundland and Greenland. In the latter regions it attains a much larger size, and is a considerable article of food.

Fathers of the Church, or CHRISTIAN FATHERS. See *Church, Fathers of the*.

Fathom, a unit of length equal to 6 feet. It is chiefly used by sailors, who measure soundings, &c., in fathoms.

Fat'imite Dynasty, a line of caliphs claiming descent from Fatima, the favourite daughter of Mohammed, and of Ali her cousin, to whom she was married. In the year 909 Abu-Mohammed Obeidalla, giving himself out as the grandson of Fatima, endeavoured to pass himself off as the Mahdi or Messiah predicted by the Koran. Denounced as an impostor by the reigning caliph of Bagdad he fled into Egypt, became caliph of Tunis, and soon conquered all Northern Africa from the Straits of Gibraltar to the borders of Egypt. His son wrested Egypt from the Abbasides in 970 and founded Cairo. The Fatimite dynasty was extinguished on the death of Adhed, the fourteenth caliph, and a new line began with Saladin.

Fatty Acids, a name given to such acids as have been separated from fats. Fats and fixed oils are composed of one or more acids combined with the radical glyceryl. By boiling with potash or soda the fat is decomposed, glycerin and a soap being the products. By treating this soap with hydrochloric or sulphuric acid the base is removed

and the fatty acid obtained free. These acids are such as butyric, caproic, stearic, margaric, palmitic, pelargonic, valerianic, acetic, &c. Formic acid has also been included in the fatty series of acids, as it belongs to the same order as those named.

Fatty Degeneration, an abnormal condition found in the tissues of the animal body, in which the healthy protoplasm is replaced by fatty granules. It is a sign of defective nutrition, and is common in old age, affecting the muscles, the heart, arteries, kidneys, &c. It is accompanied by great muscular flabbiness and want of energy, the sufferer looking at the same time fat and comparatively well.

Fatty Tissue, in anatomy, the adipose tissue, a tissue composed of minute cells or vesicles, having no communication with each other, but lying side by side in the meshes of the cellular tissue, which serves to hold them together, and through which also the blood-vessels find their way to them. In the cells of this tissue the animal matter called fat is deposited.

Fatu'ity. See *Insanity*.

Fatwa, a town, Patna district, Bengal, 8 miles from Patna city, at the junction of the Punpun with the Ganges. Pop. 10,919.

Faubourg (fō-bör), a suburb of French cities; the name is also given to districts now within the city, but which were formerly suburbs without it. Thus the *Faubourg St. Germain* is a fashionable quarter of Paris in which the ancient nobility resided.

Fau'ces (Lat. 'jaws'), in anatomy, the posterior part of the mouth, terminated by the pharynx and larynx.

Fau'cet, a form of valve or cock in which a spigot or plug opens or closes a part of a pipe for the passage of liquid.

Faucigny (fō-sē-nyē), a district of France, department of Haute Savoie, one of the loftiest districts of Europe, being partly traversed by the Pennine Alps.

Fau'cit, HELEN, Lady Theodore Martin, was born in 1816, the daughter of Mrs. Faucit the actress. She made her *début* at the Theatre Royal, Richmond, in 1833, as Juliet in *Romeo and Juliet*. She first appeared in London at Covent Garden as Julia in *The Hunchback*, in which she gained a decided success. She was one of the most important members of Macready's company during the Shaksperian revivals of 1837, and was subsequently the original representative of the heroines in Lord Lytton's *Lady of Lyons*, *Money*, *Richelieu*, &c., and in

Browning's Strafford, *Blot on the Scutcheon*, and *Colombe's Birthday*. She was married to Mr., now Sir Theodore, Martin, in 1851, since which she has rarely appeared on the stage, and latterly only for charitable purposes. Lady Martin is the authoress of a volume *On Some of Shakespeare's Female Characters*.

Fault, in geology, a fracture of strata, accompanied by a sliding down or an up-

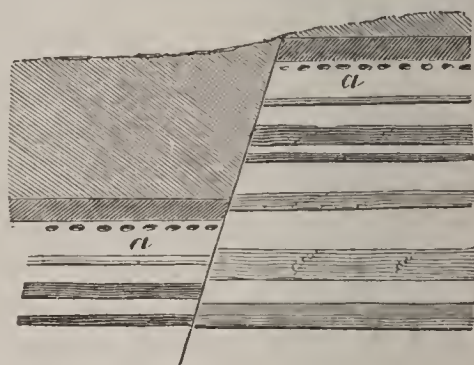

heaval of the deposits on the one side of the fracture to a greater distance than the other. Faults are frequently met with in coal-beds, the miner coming unexpectedly upon an abrupt wall of other strata. The angle this makes with the plane of the bed he is working indicates whether he must look up or down for its continuation on the other side of the fracture. In mines these faults often serve for natural drains. The cut shows at *aa* the change of position in strata caused by a fault.

Faun, one of a kind of rural deities or demigods believed in among the Romans, inhabiting the forests and groves, and differing little from satyrs. Their form was principally human, but with a short goat's tail, pointed ears, and projecting horns; sometimes also with cloven feet. There are some famous antique statues of fauns, the Dancing Faun at the Uffizi in Florence (restored by Michael Angelo), the Dancing Faun at Naples, the Faun (of Praxiteles?) at the Capitoline Museum, Rome, the Sleeping Faun, &c.

Fauna (from *faun*, which see), a collective word signifying all the animals of a certain region, and also the description of them, corresponding to the word *flora* in respect to plants.

Faust, DOCTOR JOHN, a celebrated dealer in the black art, who lived in Germany, early in the 16th century. According to some accounts he was born in Suabia, others make him a native of Anhalt, others of Brandenburg. In his sixteenth year he went

to Ingoistadt and studied theology, became in three years a *magister*, but abandoned theology, and began the study of medicine, astrology, and magic, in which he likewise instructed his familiar Johann Wagner, the son of a clergyman at Wasserburg. After Dr. Faust had spent a rich inheritance, he, according to tradition, made use of his power to conjure up spirits, and entered into a contract with the devil for twenty-four years. A spirit called *Mephistopheles* was given him as a servant, with whom he travelled about, enjoying life in all its forms, but the evil spirit finally carried him off. Even yet Dr. Faustus and his familiar Wagner play a conspicuous part in the puppet-shows of Germany, and the legend forms the subject of Goethe's great drama *Faust*, and furnishes the libretto for Gounod's famous opera of the same name. As early as 1590 the legend was dramatically treated in England by Christopher Marlowe.

Fausta, FLAVIA MAXIMIANA, daughter of Emp. Maximilian, married in 307 A.D. to Constantine the Great. She was murdered by her husband's orders in 326 A.D.

Faustina, the name of two Roman ladies: (1) Annia Galeria Faustina (died A.D. 141), the wife of the Emperor Antoninus Pius; and (2) her daughter, who was married to the Emperor Marcus Aurelius (died A.D. 175). Both were accused of dissolute conduct.

Favart (fä-vär), CHARLES SIMON, creator of the serio-comic opera in France, born 1710, was the son of a pastry-cook. His poetical reputation rests principally on his numerous productions for the *opéra aux Italiens*, and the comic opera. He was the director of a company of itinerant actors which followed Marshal Saxe into Flanders. His wife, Madame Favart, was a famous singer, comic actress, and dancer, and participated in the composition of her husband's plays. Favart died in 1792.

Faversham, a seaport of England, county Kent, on a branch of the Swale, giving name to a parl. div. of the county. It is a very ancient place, and has manufactures of brick, cement, and gunpowder. Faversham Creek is navigable up to the town for vessels of 200 tons. Pop. 1891, 10,478.

Favre (fävr), JULES, a French politician, born 21st March, 1809, at Lyons. He studied law, and after distinguishing himself at the Lyons bar came to Paris in 1835, where he became famous as a defender of political prisoners. On the outbreak of the revolution of 1848 he became secretary to Ledru-

Rollin. He was a leader of the party of opposition to the President Louis Napoleon; and after the coup d'état (1851) he retired from political life for six years, till in 1858 his defence of Orsini for the attempt on the life of the emperor again brought him forward. From this time he again became an active leader of the Republican opposition to the emperor. On the fall of the empire he became Vice-president of the Government of National Defence and Minister of Foreign Affairs. As such he conducted the negotiations for peace with Prince Bismarck. But though he showed great energy and was very eloquent, his operations both in the matter of the armistice and the peace showed a lack of skill and judgment. He died in 1880.

Favus, crusted or honey-combed ring-worm, a disease chiefly attacking the scalp, and characterized by yellowish dry incrustations. It is produced by a fungous growth.

Fawcett, HENRY, an English politician and economist, born at Salisbury in 1833. He was educated at Cambridge, studied law for a while at the Middle Temple, but soon renounced it. In 1858, when out partridge shooting, he met with an accident which inflicted on him total blindness. Undiscouraged, however, by his deprivation he gave his attention to economic studies. In 1863 he was elected to the chair of political economy at Cambridge. In 1865 he was elected M.P. for Brighton, which he represented till the general election of 1874, when he was elected for Hackney. He became Postmaster-general in the second Gladstone administration, and effected many reforms in his department. In 1883 he was made Lord Rector of Glasgow University. He died Nov. 6, 1884. Amongst his principal writings are: *A Manual of Political Economy*, *Lectures on the Economic Position of the British Labourer*, and articles on Indian finances.—His wife, MILLICENT GARRETT FAWCETT, shared her husband's studies, and has published a work, *Political Economy for Beginners*, which is an abridgment of her husband's larger works. She is also known as a prominent advocate of all measures for the educational and political advancement of women.

Fawkes, GUY. See *Gunpowder Plot*.

Fayal (fä-äl'), an island belonging to Portugal, one of the Azores. It is of a circular form, about 10 miles in diameter. The climate is good, and the air always mild and pure. The soil is very fertile, producing in

abundance wheat, maize, flax, and almost all the fruits of Europe. It exports a great quantity of oranges and lemons. The chief place is Villa Horta or Orta. Pop. 31,000.

Fayence. See *Faïence*.

Fayette, GENERAL LA. See *Lafayette*.

Fayette, MARIE MADELEINE, COUNTESS DE LA. See *Lafayette*.

Fayoum (fâ-yöm'), a province of Middle Egypt, a little to the west of the Nile, surrounded by the Libyan desert; area about 800 square miles. The soil is alluvial, and, in the north, particularly fertile. Fayoum is irrigated by canals coming from the Canal of Joseph, and that from the Nile, and is one of the most fertile provinces of Egypt. Here lay the ancient Labyrinth and the artificial lake Moeris. On the west lies Lake Birket-el-Kurun. The chief town, Medinet-el-Fayoum, is connected with Cairo by a railway. Pop. of province, 228,700.

Feasts. See *Festivals*.

Feather-grass, the popular name of *Stipa pennata*, a native of dry places in the south of Europe. The leaves are rigid, setaceous, grooved; the awns exceedingly long, feathering to the point. It is a great ornament to gardens in summer, and to rooms in winter. The Rush-leaved Feather-grass is found in prairies in the Western States.

Feather-moth. See *Plume-moth*.

Feathers, the form which the dermal appendages assume in birds, agreeing in mode of development, but differing in form from hairs and scales. The feather consists of a stem, horny, round, strong, and hollow in the lower part, called the *quill*, and in the upper part, called the *shaft*, filled with pith. On each side of the shaft is a web composed of a series of regularly-arranged fibres called *barbs*. The barbs and shaft constitute the *vane*. On the edges of the barbs are set the *barbules*, which interlock with those of adjacent barbs, and thus give strength to the vane. Feathers are generally divided into two kinds, quill feathers in the wing or tail, and plumes or clothing feathers generally diffused. The feathers of birds are periodically changed, generally once, but in some species twice a year. This is called *moulting*. When feathers have reached their full growth they become dry, and only the tube, or the vascular substance which it contains, continues to absorb moisture or fat. When, therefore, part of a feather is cut off, it does not grow out again; and a bird whose wings have been clipped remains in that situation till the next moulting

season, when the old stumps are shed and new feathers grow out. If, however, the stumps are pulled out sooner (by which operation the bird suffers nothing), the feathers will be renewed in a few weeks or even days. The feather is a very strong formation, not readily damaged, the arch of the shaft resisting pressure, while the web and fine fibres yield without suffering. Being a bad conductor of heat it preserves the high temperature of the bird, while it is so light as to be easily carried in flight. It is rendered almost impervious to wet by the oily fluid which most birds secrete at the base of the tail. Feathers form a considerable article of commerce, particularly those of the ostrich, heron, swan, peacock, goose, &c., for plumes, ornaments, filling of beds, pens, &c.

Feather-star, *Comatula rosacæa*, a beautiful crinoid star-fish occurring on the British coasts, consisting of a central body or disc, from which proceed five radiating arms, each dividing into two secondary branches, so that ultimately there are ten slender rays. Each arm is furnished on both sides with lateral processes so as to assume a feather-like appearance. It is fixed when young by a short stalk, but exists in a free condition in its adult state.

Feb'ric'ula, a short feverish attack, lasting only for a few days. See *Fever*.

Feb'rifuge, a medicine employed to drive off or diminish fever, such as quinine.

Febro'nianism, in Roman Catholic theology, a system of doctrines antagonistic to the admitted claims of the pope, and asserting the independence of national churches, and the rights of bishops to unrestricted action in matters of discipline and church government within their own dioceses. The term is derived from Justinus *Febronius*, a *nom de plume* assumed by John Nicholas von Hontheim, archbishop of Trèves, in a work on the claims of the pope.

Feb'ruary (from the Roman *Februa*, a festival of expiation or purification), the second month in the year, having twenty-eight days, except in leap-year, when it has twenty-nine. This latter number of days it had originally among the Romans, until the senate decreed that the seventh month should bear the name of Augustus, when a day was taken from February and added to August to make it equal to July in number of days.

Fécamp (fâ-kän), a seaport of France, department of Seine-Inférieure, 23 miles

north-east of Havre. It is one of the best ports in the Channel, and has many vessels employed in the cod, herring, and mackerel fisheries. Pop. 12,362.

Federal Party, a name assumed by that portion of the people of the U. States who favoured the adoption of the Federal constitution, organized the government and administered it for twelve years. They advocated a government having attributes of sovereignty, operating upon the people directly, and having all necessary powers for effective action; their opponents favoured a simple compact of confederation.

Federal Government, government by the confederation of several united states, self-governing in local matters, but subject in matters of general polity to a central authority, as, for instance, the Swiss Republic, the United States of North America, Mexico, &c. The degree to which such states give up their individual rights as sovereign bodies may be very different.

Fee, or **FIEF**, in law, primarily meant a loan of land, an estate held in trust on condition of the grantee giving personal or other service to the prince or lord who granted it. Feudal estates, however, soon came to be regarded as inalienable heritages held on various tenures; hence the term fee came to be equivalent to an estate of inheritance, that is an interest in land which passes to heirs if the owner die intestate. The amplest estate or interest in land is that of a *fee-simple*, which is also called an absolute fee, in contradistinction to a fee limited or clogged with certain conditions. A fee-simple means the entire and absolute possession of land, with full power to alienate it by deed, gift, or will. It is the estate out of which other lesser estates are said to be carved; such as a *fee-tail* (see *Entail*), which is limited to particular heirs, and subject to certain restrictions of use; and a *base fee*, which ceases with the existence of certain conditions.

Fee-farm, in law, a kind of tenure of land without homage, fealty, or other service, except that mentioned in the feoffment, which is usually the full rent.

Feejee. See *Fiji*.

Feeling is properly a synonym for sensation, or that state of consciousness which results from the application of a stimulus to the extremity of some sensory nerve. It is the most universal of the senses, existing wherever there are nerves; and they are distributed over all parts of the body, though

most numerous on such parts as the fingertips and the lines where skin and mucous membrane pass into each other. This universal distribution of feeling is necessary, otherwise parts of the body might be destroyed without our knowledge. The structures which thus apprehend the impressions of contact are papillæ or conical elevations of the skin in which the nerves end, and which are richly supplied with blood-vessels. The term feeling is also used for a general sense of comfort or discomfort which cannot be localized, and it is thus that the disturbances of internal organs often manifest themselves. In a figurative sense the term is also applied to a mental emotion, or even to a moral conception; thus we may speak of a friendly feeling, a feeling of freedom.

Felaniche (*fel-â-nē'chā*), a town in the island of Majorca, a very ancient place with Moorish remains. Pop. 9752.

Felegyhaza (*fā'led-yä-sä*), a town of Hungary, 66 miles s.e. of Budapest, with large cattle-markets and an extensive trade in corn, wine, and fruit. Pop. 1891, 30,406.

Felicu'di, one of the Lipari Isles, off the north coast of Sicily, 10 miles west of Salina. It is about 9 miles in circuit. The soil is both fertile and well cultivated. Pop. 800.

Fe'lidæ, animals of the cat kind, a family of Carnivora in which the predaceous instincts reach their highest development.

They are among the quadrupeds what the Falconidæ are among the birds. The teeth and claws are the principal instruments of the destructive energy in these animals. The incisor teeth are equal; the third tooth behind the large canine in either jaw is narrow and sharp,

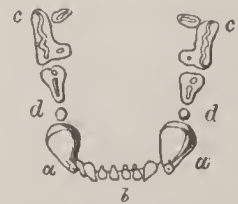
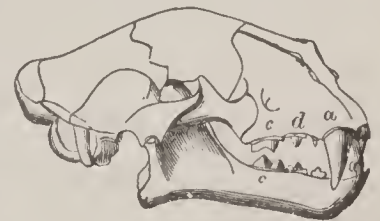

Teeth of Felidæ.

Skull and Teeth of the Tiger. *a*, Canines or tearing teeth. *b*, Incisors or cutting teeth. *c*, True molars or grinding teeth. *d*, Carnassial or sectorial teeth.

work against each other like scissors in cutting flesh: the claws are sheathed and retractile. They all approach their prey stealthily, seize it with a spring, and devour it fresh. The species are numerous in Europe, Asia, Africa, and America,

but none are found in Australia. The family comprehends the lion, tiger, leopard, lynx, jaguar, panther, chetah, ounce, serval, ocelot, cat, &c.

Felix, ANTONIUS or CLAUDIUS, procurator of Judea and freedman of the Emperor Claudius, is described by Tacitus as unscrupulous and profligate both in his public and private conduct. It was before this Felix that Paul's discourse (Acts xxiv. 25) was spoken. He was recalled A.D. 62, and narrowly escaped condemnation at Rome on charges which the Jews had lodged against him.

Felix, MARCUS MINUCIUS, a distinguished Roman lawyer, who embraced Christianity, and wrote a defence of it in a dialogue entitled *Octavius*. The period when he flourished is uncertain; but Jerome is probably right in placing him about A.D. 230.

Fellah, an Arabian word meaning 'peasant,' and used for the labouring class in Egypt. The fellahs or *fellaheen* constitute about three-fourths of the population of Egypt, and are mostly the direct descendants of the old Egyptians, although both their language and religion are now that of their Arabian conquerors. They live in rude huts by the banks of the Nile, and have suffered much from over-taxation and oppressive rule. See *Egypt*.

Fella'tah, FULBE, or FULAHS, a remarkable African race of the negro type, the original locality of which is unknown, but which is now widely diffused throughout the Soudan, where they are the predominant people in the states of Futa-Toro, Futa-Jalon, Bondu, Sokoto, &c. Though of the negro family, they have neither the deep jet colour, the crisped hair, flat nose, nor thick lips of the negro. In person they are decidedly handsome, and mostly of a light copper colour. They are shrewd, intelligent, and brave, and are mostly Mohammedans. Their influence is continually spreading.

Fel'enberg, PHILIP EMANUEL VON, Swiss educationalist, born in 1771. Having devoted himself to the social and intellectual improvement of the peasantry, he purchased the estate of Hofwyl, and established successively an institution for instructing the children of the poorer classes, a seminary for children in the higher grades of life, and a normal school. The pupils were all trained to work in the fields or at the bench, and the product of their labour was sufficient to cover the expenses of their education. Fellenberg's scheme was ultimately so suc-

cessful as to attract the attention even of foreign governments. He died in 1844, but the institutions established by him still exist in a modified form.

Fel'lows, SIR CHARLES, traveller and antiquarian, was born in 1799 at Nottingham. He first explored the valley of the Xanthus in Lycia, in 1838, and discovered the remains of the cities Xanthus and Teos. Under the auspices of the trustees of the British Museum he made further explorations in 1839 and 1841, and succeeded in obtaining the marbles now in the Lycian saloon of the Museum. He was knighted by the queen in 1845. He died in 1860. His principal works are: *Travels and Researches in Asia Minor*, and *Coins of Ancient Lycia before the Reign of Alexander*.

Fellowship, an honourable position in some universities, especially those of Oxford and Cambridge, which entitles the holder, called a fellow, to an annual stipend for a certain period. Fellowships in the English colleges commonly range in value from about £150 to £250 or £300 a year, and they all confer upon their holders the right to apartments in the college, and certain privileges as to commons or meals. Formerly they were usually tenable for life or till the attainment of a certain position in the church or at the bar, or till marriage; but six or seven years is now a common period during which they may be held, though this may be prolonged in certain circumstances.

Felo de se (Latin, 'a felon in regard to himself'), in law, a person that, being of sound mind and of the age of discretion, deliberately causes his own death. Formerly, in England, the goods of such a person were forfeited to the crown, and his body interred in an ignominious manner; that is, unless the coroner's jury gave a verdict of unsound mind; but these penalties have been abolished.

Fel'ony, in law, includes generally all crimes below treason and of greater gravity than misdemeanours. Formerly it was applied to those crimes which entailed forfeiture of lands or goods as part of the punishment.

Fel'spar, FELDSPAR, a mineral widely distributed, and usually of a foliated structure, consisting of silica and alumina, with potash, soda, or lime. It is a principal constituent in all igneous and metamorphic rocks, as granite, gneiss, porphyry, greenstone, trachyte, felstone, &c. When in crystals or

crystalline masses it is very susceptible of mechanical division at natural joints. Its hardness is a little inferior to that of quartz. There are several varieties, as common felspar or orthoclase, the type of an acid group containing from 7 to 16 per cent of potash; albite and oligoclase, soda felspars, the quantity of soda exceeding that of lime; labradorite and anorthite, lime felspars, the quantity of lime in the latter amounting to 20 per cent.

Felt, a kind of cloth made of wool, or of wool and cotton united by rolling, beating, and pressure. The materials to be felted are carded and placed in a machine, where they are kept wet and intimately mixed together by a process of beating. Pressure then unites the whole into a compact mass. The use of felt as a material for hats, tents, cloaks, &c., is very ancient. For hat-making the fur of rabbits, beavers, raccoons, and the wool of sheep is generally used. Felt being a good non-conductor of heat is much used for roofing, sheathing boilers, hot-water reservoirs, &c. The felt for such purposes is made from the coarsest woollen refuse from paper-mills.

Feltre (fel'trā), a town in Northern Italy, about 44 miles N.N.W. from Venice. Pop. 12,566.

Feluc'ca, a long narrow vessel, generally undecked, of light draught, and rigged with large lateen sails. They also carry from eight to twelve large oars. They are common in the Mediterranean.

Feme Covert, in law, signifies a married woman, in contradistinction to a *feme sole*, or single woman.

Femern (fā'mern), an island of Prussia, province of Schleswig-Holstein, separated from the mainland by a shallow strait about 1 mile broad. The island has a fertile but marshy soil. The inhabitants are chiefly agriculturists and fishers. Pop. 9800.

Femgerichte, FEHMGERICHTE, or VEHMGERICHTE (fām'ge-rih-te; from Old German, *fem*, punishment, and *gericht*, a court), criminal courts of Germany in the middle ages, which took the place of the regular administration of justice (then fallen into decay), especially in criminal cases. These courts originated and had their chief jurisdiction in Westphalia, and their proceedings were conducted with the most profound secrecy. They seem to have been a survival of old territorial jurisdictions which, on the general distraction and lawlessness prevalent after the fall of Henry the Lion (1182), acquired

an extensive and tremendous authority. In process of time, however, they degenerated, and no longer confined themselves to law and precedent, so that the secrecy in which they enveloped themselves only served as a cloak to their criminal purposes. The flagrant abuse of their power brought about their fall. In 1461 various princes and cities of Germany, as well as the Swiss confederates, united in a league against them, but their influence was not entirely destroyed until an amended form of trial and penal judicature was introduced. The last Femgericht was held at Zell in 1568. The president of the secret tribunal was called the *Freigraf*, and was generally a prince or count. His associates, who concurred in and executed the sentence, were called *Freischöffen*. These were scattered through all the provinces of Germany, and recognized one another by certain signs and watchwords. They acknowledged the emperor as their superior, and for this reason generally made him one of their number at his coronation at Aix-la-Chapelle. The assemblies of the tribunal were open or secret. The former were held by day in the open air; the latter by night, in a forest or in concealed and subterranean places. In these different cases the circumstances of judgment and the process of trial were different. The crimes of which the secret tribunal usurped cognizance were heresy, sorcery, rape, theft, robbery, and murder. The accusation was made by one of the *Freischöffen*, who, without further proof, declared upon oath that the accused had committed the crime. The accused was now thrice summoned to appear before the secret tribunal, and the citation was secretly affixed to the door of his dwelling or some neighbouring place; the accuser remained unknown. If, after the third summons, the accused did not appear, he was once more cited in a solemn session of the court, and if still contumacious, was given over to the *Freischöffen*. The first *Freischöffe* who met him was bound to execute the decree of the court. A dagger was left by the corpse to show that it was not a murder, but a punishment inflicted by one of the *Freischöffen*. How many judicial murders were perpetrated in this manner from revenge, interested motives, or malice, may well be imagined.

Fe'mur, in vertebrate animals, the first bone of the leg, situated next the trunk of the body, and in man popularly called the thigh-bone.

Fen, a marsh or stretch of wet boggy land often containing extensive pools. The *Fens*, or the *Fen District*, is a special term for a marshy district of England, extending into the counties of Cambridge, Lincoln, Huntingdon, Northampton, Norfolk, and Suffolk. A great part of the district is known as Bedford Level (which see). Much of the land has been reclaimed at vast expense. The soil of fen lands is generally black and rich to a depth of 2 or 3 feet, and with proper management in the matter of draining they will produce heavy crops of grass and corn.

Fences, continuous lines of obstacles artificially interposed between one portion of the surface of the land and another for the purpose of separation or exclusion. Live fences are made of hawthorn, holly, box, beech, &c.; dead fences of stone, wood, and in recent times of iron or wire. In agriculture fences are necessary both for restricting the tenant's own animals to their pasture, and for protecting his land from straying animals. The general erection of fences on farms is one of the improvements of modern agriculture.

Fencibles, a sort of local militia raised for defence in case of invasion, and not liable to be sent to serve out of the country. The term *volunteers* is now used for this kind of service.

Fencing, the art of attack and defence with sword or rapier, no shield being used. It was in Italy in the 16th century that the skilful use of the small sword first became common. The art spread to Spain and then to France, where, on account of the prevalence of duelling, it was brought to a high degree of development. The small sword or rapier (which was adopted for duelling) has a point, but no edge, and therefore demands the highest degree of adroitness in its use. In the fencing schools the instrument adopted for exercise is called a foil; it has a guard of metal or leather between the handle and blade, which is made of pliant steel and has a button at the end in place of a point. The parries are made with the weapon itself by opposing the *forte* of the foil (*i.e.* the strong part from the handle to the centre) to the *feible* of the adversary's foil (*i.e.* to the part from centre to point); the upper part of the body to the right is defended by the parry called *tierce*, the upper part to the left by the *carte*, and the lower part by the *seconde*. In all parrying care must be taken that in covering the

side attacked the other side is not too carelessly exposed to the enemy. After every parry a return should be made with rapidity and decision. The fencer should rely more upon his sword hand for protection than upon his agility of leg; yet he must be active on his legs so as to advance, retreat, or lunge with effect. The knees should therefore be somewhat bent when the fencer is on guard, that he may be light and elastic in his movements. An attack may be made by the mere extension of the arm, or accompanied by a lunge, that is, by advancing the body, stepping forward with the right foot without moving the left. An *engagement* means the crossing of the blades; a *disengagement*, slipping your foil under the opponent's and then pressing in the opposite direction; *riposte*, the attack without pause by a fencer who has parried. Fencing with the broadsword differs essentially from that with the foil, as the former has an edge as well as a point, and is therefore meant to cut as well as thrust. According to the instructions of drill-masters there are seven cuts, with corresponding guards, and three thrusts. Cut *one* is a diagonal, downward cut at the left cheek of the adversary; cut *three* is delivered with an upward slope at the left leg, and cut *five* horizontally at the right side; cuts *two*, *four*, and *six* attack the right cheek, right side, and right leg respectively; and cut *seven* is directed vertically at the head. Guards *one* and *two* defend the upper portion of the body, the sword sloping upwards in an opposite direction to the opponent's; guards *three* and *four* protect the legs, the sword sloping downwards; guards *five* and *six* defend the sides, when the sword is held vertically, point downwards; and guard *seven* protects the head, the blade meeting the enemy's almost at a right angle. Since the introduction of the bayonet, bayonet exercise has become an important department of fencing in the army. In handling the bayonet defensively the right foot is thrown back and receives most of the weight of the body, the knees are bent, the bayonet brought to a horizontal position level with the waist. This is the 'guard,' and according to the parry to be made the weapon is carried either to the 'high' position, pointing upwards from the breast, or to the 'low' position, pointing downwards from the breast. In taking the offensive the right leg is straightened, and the left bent forward, without moving the feet from their place.

The butt of the rifle is pressed firmly to the shoulder and points straight forward. In 'shortening arms' the butt is carried back to the full extent of the right arm, while the barrel (turned downwards) rests upon the left arm. The body rests upon the right leg, which is slightly bent, while the left is somewhat advanced.

Fénelon (fān-lōū), FRANÇOIS DE SALIGNAC DE LA MOTHE, one of the most venerable of the French clergy, born in 1651 at the Château Fénelon, in Périgord, of a family illustrious in church and state. A gentle disposition, united with great vivacity of mind and a feeble and delicate constitution, characterized his youth. He was educated under the eye of his uncle, the Marquis of Fénelon, and afterwards at St. Sulpice, Paris. He took orders at the age of twenty-four, and distinguished himself in the work of converting Protestants. In 1681 his uncle conferred on him the priory of Carennac. Soon after he wrote his first work, *Traité de l'Éducation des Filles*, which was the basis of his future reputation. In 1689 Louis XIV. intrusted to him the education of his grandsons, the Dukes of Burgundy, Anjou, and Berri. In 1694 he was created Archbishop of Cambrai. A theological dispute (see *Quietism*) with Bossuet, the virtual head of the French Church, terminated in his condemnation by Pope Innocent XII., and his banishment to his diocese by Louis XIV. Fénelon submitted without the least hesitation, and thenceforward lived contentedly in his diocese, sustaining the venerable character of a Christian philosopher, and scrupulously performing his sacred duties. He died in 1715. He left numerous works in philosophy, theology, and belles-lettres. The most celebrated is *Les Aventures de Télémaque*, in which he endeavoured to exhibit a model for the education of a prince. It was commonly taken for a satire on the reign of Louis XIV., though nothing, probably, was further from the mind of Fénelon.

Fenians, a name usually derived from Fionn or Finn, the name given to a semi-mythical class of Irish warriors famous for their prowess. The name has been assumed in recent years by those Irish who formed a brotherhood in their own country and in America, with the intention of delivering Ireland from the sovereignty of England, and establishing an Irish republic. About the end of 1861 the Fenian Brotherhood was regularly organized in America; and its chief

council, consisting of a 'head-centre,' John O'Mahony, and five other members, which had its seat at New York, soon had branches in every state of the Union; while at the same time large numbers joined the cause in Ireland, where James Stephens was 'head-centre.' The close of the American civil war, when large numbers of trained Irish soldiers who had taken part in the war were released from service, was thought to be a convenient time for taking some decisive steps. Two risings were planned in Ireland, but they were both frustrated by the energetic measures of the British government, the first, in September, 1865, by the seizure of the office of the Irish People, the Fenian journal published at Dublin, in which papers were found which revealed to the government the secrets of the conspiracy, and which led to the capture of the ringleaders, Luby, O'Leary, O'Donovan Rossa, and others; the second, in February, 1866, was as speedily suppressed by the suspension of the Habeas Corpus Act in Ireland. An invasion of Canada, attempted in the same year, failed as miserably as the attempt in Ireland, and convinced the Irish that they could not expect the aid from the United States on which they had hitherto counted. At last, on 5th March, 1867, the long-prepared insurrection broke out almost simultaneously in the districts of Dublin, Drogheda, and Kerry. The number of insurgents in the field, however, did not exceed 3000, and though they burned some police stations, they nowhere faced the troops sent after them. About the same time some forty or fifty Irish-Americans landed in a steamer near Waterford, but soon after fell into the hands of the police. In 1870 and 1871 two raids were again made on Canada, but both were ridiculous failures, the first being repulsed by the Canadian Volunteers, and the second suppressed by the United States government. At present the brotherhood seems to have suspended active operations.

Fennec (*Canis zerda*), a small animal allied to the dog and fox, and sometimes called the Sahara fox, being a native of that region. It lives on birds, jerboas, lizards, dates, &c., burrows with great facility, and is easily tamed. It is fox-like in appearance, and is remarkable for the great size of its ears.

Fennel, a fragrant plant, *Feniculum vulgare*, cultivated in gardens, belonging to the nat. order Umbelliferae. It bears umbels of

small yellow flowers, and has finely-divided leaves. The fruit, or in common language the seeds, are carminative, and frequently employed in medicine.—*Giant fennel* is a popular name for *Ferūla commūnis*, which attains sometimes a height of 15 ft.

Fen'ugreek, a leguminous plant, *Trigonella Fœnum græcum*, whose bitter and mucilaginous seeds are used in veterinary practice. It is an erect annual, about 2 ft. high, a native of the south of Europe and of some parts of Asia.

Fe'odor, the name of three Russian princes.—**FEODOR I.**, son of Ivan the Terrible, reigned from 1584-98. He was a feeble prince, who allowed himself to be entirely governed by his brother-in-law, Boris Godunov. With him the Russian dynasty of Rurik became extinct.—**FEODOR II.**, son of Boris Godunov, reigned only for a short time in 1605.—**FEODOR III.**, the son of Czar Alexis, reigned from 1676-82, warred with the Poles and Turks, and, by the peace of Baktschisarai, obtained possession of Kiev and some other towns of the Ukraine.

Feodo'sia (formerly *Kaffa*), a town in Russia, in the south-east of the Crimea. From 1266 to 1474 this town was in possession of the Genoese, in whose hands it became the seat of an extensive commerce with the East, and is said to have had a population of 80,000. It is still one of the most important towns in the Crimea. Pop. 9882.

Feoffment (fef'ment), in law, that mode of conveying property in land where the land passes by livery in deed, that is, actual delivery of a portion of the land, as a twig or a turf; or when the parties, being on the land, the feoffer expressly gives it to the feoffee. As the statute of uses has introduced a more convenient mode of conveyance, feoffments are now rarely used except by corporations. See *Seizin*, *Sasine*.

Feræ naturæ ('of a wild nature'), the name given in the Roman law to beasts and birds that live in a wild state, as distinguished from those which are *domitæ naturæ*, that is, tame animals, such as horses, sheep, &c. The right of property in such animals exists only as long as they are in a state of confinement or within the boundaries of the possessor's lands, unless it can be proved that any special animal had been trained to return to its master's property.

Fer-de-lance (fer-de-läns), the lance-headed viper or *Craspedocephalus (Bothrops) lanceolatus*, a serpent common in Brazil and

some of the West Indian Islands, and one of the most terrible members of the rattlesnake family (*Crotalidæ*). It is 5 to 7 ft. in length. The tail ends in a horny spine which scrapes harshly against rough objects but does not rattle. Its bite is almost certainly fatal.

Fer'dinand, German emperors:—1. **FERDINAND I.**, brother of Charles V., and born at Alcala, in Spain, 10th March, 1503. In 1522 he received the Austrian lands of the house of Hapsburg from the emperor, to which were afterwards added the kingdoms of Hungary and Bohemia in right of his wife Anna of Hungary. On the abdication of Charles he succeeded to the imperial title. He died 25th July, 1564.—2. **FERDINAND II.** was born in 1578, and succeeded his uncle Matthias as Emperor of Germany in 1619. He was of a dark and reserved character, and had been brought up by his mother and the Jesuits in fierce hate of Protestantism. The result was a quarrel with his Bohemian subjects, who openly revolted and offered the Bohemian crown to the Elector Palatine, a step which led to the outbreak of the Thirty Years' war (1619). (See article under that head.) With the help of the Catholic League and John George, Elector of Saxony, he was placed firmly on the throne of Bohemia, where he relentlessly persecuted the Protestants. He died Feb. 15, 1637.—3. **FERDINAND III.**, son of the preceding, was born in 1608, and succeeded his father in 1637. He had served in the Thirty Years' war and had seen the miseries which it occasioned and was reluctant to continue it. There were eleven years more of it, however, before the Peace of Westphalia was concluded in 1648. Ferdinand died in 1657.

Ferdinand V., King of Aragon, who received from the pope the title of *the Catholic*, on account of the expulsion of the Moors from Spain, was the son of King John II., and was born March 10, 1453. On the 18th of October, 1469, he married Isabella of Castile, and thus brought about that close connection between Aragon and Castile which became the basis of a united Spanish monarchy and raised Spain to pre-eminence amongst European states. After a bloody war of ten years they conquered Granada from the Moors (1491); but the most brilliant event of their reign was the discovery of America, which made them sovereigns of a new world. (See *Columbus*.) This politic prince laid the foundation of the

Spanish ascendancy in Europe by the acquisition of Naples (1503), and by the conquest of Navarre (1512); but his policy was deceitful and despotic. He instituted the court of the Inquisition at Seville in 1480, and, to the great injury of Spanish commerce, expelled the Jews (1492) and Moors (1501). He died in 1516.

Ferdinand I. of Bourbon, King of the Two Sicilies (previously Ferdinand IV. of Naples), born January 12, 1751, was the third son of Charles III., King of Spain, whom he succeeded in 1759, on the throne of Naples, on the accession of the latter to that of Spain. In 1768 he married Maria Caroline Louisa, daughter of the Empress Maria Theresa, who soon acquired a decided influence over him. After the death of Louis XVI. Ferdinand joined the coalition against France, and took part in the general war from 1793 to 1796; but in 1799, after the defeat of the Neapolitans under Gen. Mack, the French took possession of the whole kingdom, and proclaimed the Parthenopean Republic. The new republic did not last long. Ferdinand returned to Naples in 1800. Six years later he was again driven from Naples by the French, and compelled to take refuge in Sicily, where he maintained himself by the aid of the British. The Congress of Vienna finally re-established Ferdinand IV. in all his rights as King of the Two Sicilies in 1814, while Naples was still occupied by Murat. But after the flight of the latter in March, 1815, Ferdinand once more entered Naples, June 17, 1815. In 1816 he assumed the title of Ferdinand I., King of the Two Sicilies. In 1820, in consequence of a revolution, Ferdinand was obliged to swear to support a new and more liberal constitution. The Austrians, however, came to his help, and re-established him in possession of absolute power. He died in January, 1825, and was succeeded by his son, Francis I.

Ferdinand II., King of the Two Sicilies, born in 1810, succeeded his father Francis I. on the 8th of November, 1830. The revolution of France in this year had unsettled the minds of men throughout the Continent generally, and Ferdinand was at first forced to make some concessions to his subjects, but soon recalled them, determining thenceforward to make his will the only law. The result was a series of popular outbreaks, culminating in the year 1848, when Ferdinand earned the nickname of King Bomba, by bombarding his capital from the forts.

Despotism was again established by force of arms, and when Bomba died, on 22d May, 1859, his prisons were crowded with the best and bravest of his subjects. He was succeeded by his son, Francis II., who lost his crown when Italy was united in 1860 under Victor Emmanuel.

Ferdinand VII., King of Spain, eldest son of Charles IV., and of Maria Louisa of Parma, born in 1784; ascended the throne in March, 1808, when a popular rising forced his father to abdicate in his favour. A month later he himself abdicated in favour of Napoleon, who conferred the crown on his brother Joseph. Ferdinand returned to Spain in March, 1814. His arbitrary conduct caused an insurrection in 1820, which was at first successful, but Louis XVIII. of France having sent an army to his aid, his authority was once more made absolute in Spain. Having no sons he abolished the act of 1713 by which Philip V. had excluded women from the throne of Spain, and then left his crown to his daughter Isabella to the exclusion of his brother, Don Carlos. It was during the reign of this king that the Spanish colonies in America broke away from the mother country.

Ferdinandea. See *Graham Island*.

Fère (fâr), LA, a town of N. E. France, department of Aisne, at the confluence of the Serre and the Oise, a fortress of the second rank. Pop. 3243.

Ferenti'no, a town in Central Italy, 6 miles north-west of Frosinone. It has remains of ancient walls, built of hewn stone without mortar. Pop. 9096.

Fer'etory, a kind of box made of gold or other metal, or of wood variously adorned, and usually in the shape of a ridged chest, with a roof-like top, for containing the relics of saints. It is borne in processions.



Feretory.

Ferghana', a province of Asiatic Russia in Turkestan, formed in 1876 out of the conquered khanate of Khokand. It consists mainly of a valley surrounded by high ranges of mountains and traversed by the Sir-Darya and its tributaries; area, 36,000 sq. miles. The climate is warm, and the soil in part fertile, but a considerable portion of the country is desert. Pop. about 716,000. Khokand is the capital.

Fer'guson, ADAM, Scottish historical and political writer, born in 1724, died in 1816. In 1757 he succeeded David Hume as keeper of the Advocates' Library, Edinburgh, in 1759 was made professor of natural philosophy in the university, and in 1764 of moral philosophy. He resigned his chair in 1784. Among his chief works are an Essay on Civil Society (1767), Institutes of Moral Philosophy (1769), History of the Roman Republic (1783), Moral and Political Science (1792).

Ferguson, JAMES, an eminent experimental philosopher, mechanist, and astronomer, was born of poor parents at Keith, in Banffshire, in 1710. While a boy tending sheep he acquired a knowledge of the stars, and constructed a celestial globe. With the help of friends he went to Edinburgh, where he studied mathematics and drawing, making such rapid progress in the latter that he was able to support himself by taking portraits in miniature. In 1743 he went to London, where he painted and gave lectures in experimental philosophy. Amongst his hearers was George III., then Prince of Wales, who afterwards settled on him a pension of £50 a year. He died in 1776. His principal works are: Astronomy Explained upon Sir Isaac Newton's Principles (1756); Lectures on Mechanics, Hydrostatics, &c. (1760); Select Mechanical Exercises (1773).

Ferguson Bequest, a Scottish fund named from John Ferguson, a native of Irvine, who died in 1856, leaving about half a million for philanthropic purposes. Of this £400,000 were set apart as a fund for aiding in the erection of churches and schools, supplementing the income of ministers, missionaries, and teachers of schools, and maintaining public libraries. Only *quoad sacra* Established Churches, Free, United Presbyterian, and Congregational Churches share in the benefits. The Ferguson Scholarships in classics, mathematics, and philosophy respectively, one in each subject annually open to competitors from all the Scotch universities, were also founded by him.

Fergusson, JAMES, a writer on architecture, born at Ayr in 1808. He went out to India as partner of an important commercial house, but after some years retired from business to devote himself to the study of architecture and early civilizations. In 1845 he published Illustrations of the Rock-cut Temples of India; in 1849, A Historical Enquiry into the True Principles of Beauty

in Art; in 1851, The Palaces of Nineveh and Persepolis Restored; in 1855, Illustrated Handbook of Architecture; in 1862, History of the Modern Styles of Architecture, a sequel to the handbook, both being afterwards combined in History of Architecture in All Countries (3 vols. 1865-67), and completed by a History of Indian and Eastern Architecture (1876). He also wrote on the site of the Holy Sepulchre at Jerusalem; Tree and Serpent Worship; Rude Stone Monuments in All Countries, &c. He died in 1886.

Fergusson, ROBERT, a Scottish poet of distinguished merit, was born at Edinburgh October 17, 1750. He was educated at St. Andrews University, and became clerk to a writer of the signet in Edinburgh. He wrote poems, of which those in the Scottish dialect have genuine poetic excellence. Social excesses, into which he was led, impaired his feeble constitution, and brought on disease, which terminated his existence October 16, 1774. He was buried in the Canongate Churchyard, Edinburgh, where Burns erected a monument to the memory of this kindred genius, to whom he owed suggestions for several of his own poems.

Ferish'ta, more properly Mohammed Kasim, a Persian historian, born at Astrabad about 1550. He went to India with his father, and was for some time the tutor of a native prince. He wrote a history of the Mohammedan Power in India, which is the best yet written on the period which it embraces. He died about 1612.

Fermanagh (fer-mä'nä), an inland county in Ireland, in the province of Ulster; area, 714 sq. miles, or 457,369 acres. The county is divided lengthwise into two nearly equal portions by Lough Erne, and exhibits a succession of abrupt eminences of slight elevation, but is mountainous towards its western boundary. The soil is variable, and not remarkably fertile. The manufactures are unimportant. Politically it is divided into North Fermanagh and South Fermanagh, each sending one member to parliament. Pop. 1891, 74,037.

Fermentation, the spontaneous conversion of an organic substance into new compounds by the influence of a ferment, these ferments being apparently vegetable organisms of extremely simple type, which by their life, growth, and increase set up fermentation. There are several kinds of fermentation: 1st, the *vinous* or *alcoholic* fermentation—the most important from an

economic and industrial point of view—in which the sugar contained in liquids is converted into alcohol, carbonic acid, and glycerin; 2d, the *acid* fermentation, in which spirituous liquors become acid, producing acetic acid; 3d, the *putrid* fermentation, by which organic substances undergo various alterations according to the nature of the substance, and generally set free poisonous gases. Fermentation is also described as lactic, butyric, &c., according to the nature of the results. The general course of alcoholic fermentation, as seen in brewing and wine making, is as follows:—After a lapse of time, which may vary much according to the temperature and other conditions, the liquid acquires a turbid appearance, there is a slight disengagement of gas, which increases till the liquid begins to effervesce, its temperature rises to a higher point than that of the surrounding air, and its surface becomes covered with a frothy matter known as yeast. The effervescence becomes more and more violent till a climax is reached, when its intensity gradually diminishes, and the disengagement of gas ceases. The yeast then settles down at the bottom of the liquor, which is now entirely deprived of its sugar, and has the characteristic taste and effects of ‘fermented liquors.’ The rationale of this process has long been the subject of much discussion, but there can be little doubt that it is due to microscopic organisms (the yeast fungus) which live and multiply in the liquid in which they cause fermentation. And the fermentation may be checked or altogether prevented by anything which prevents the growth of the fungus, for example by the presence of any antiseptic substance such as sulphuric acid, carbolic acid, &c., which acts as a poison on the fungus; or by the liquid being either too hot or too cold (below 50° or above 86° Fahr.). Fermentation differs in kind according to the nature of the substance which produces it, and each kind is the special production of a certain species of organism, no two of which will ever pass into each other. *Lactic fermentation*, such as occurs in milk that has been allowed to stand, is caused, according to Pasteur, by the development in the mass of a microscopic fungus, *Penicillium glaucum*, the sugar of the milk being converted into lactic acid. The *acid* or *acetous fermentation* occurs in liquids which have already undergone vinous fermentation. When exposed to the atmosphere such liquids become sour,

and vinegar is produced. This change is probably due to the growth of a fungus, *Mycoderma acēti* (the vinegar plant). *Viscous fermentation* often accompanies vinous fermentation, making the wine thick and viscous so that it runs out in threads when poured. It occurs at temperatures ranging from 68° to 104° Fahr. *Butyric fermentation* follows on lactic fermentation when the latter is allowed to proceed after lactate of lime has been formed. It is believed that putrefaction is only a species of fermentation, determined by ferments of the bacteria class. As it is commonly maintained that fermentation may be set up by the necessary germs entering the liquors from the air in which they float, the theory of fermentation has a close connection with that of the germ theory of disease. See *Germ Theory*.

Ferment'ed Liquors, alcoholic beverages obtained by the fermentation and clarification of saccharine fluids. These have been in use from the earliest times. Amongst the commonest kinds are *wine* made from the juice of the grape; *ale* or *beer* made from an infusion of malt; *cider*, from apples; *mead*, from honey; *kumiss* made by the Kirghiz from mares' milk; *chica* from maize by the South American Indians; &c. From all fermented liquors a spirit may be extracted by distillation.

Fer'ments, certain substances which, under particular conditions, excite fermentation. Some are of inorganic nature, but the most important are organic. See *Fermentation*.

Fermo, a town of Middle Italy, province of Ascoli, on a height about 4 miles from the Adriatic, on which is its port, Porto di Fermo. Pop. 6692.

Fermoy', a town in Ireland, county Cork, on the Blackwater. It contains Fermoy College and St. Colman's Roman Catholic College, and has barracks accommodating 3000 men. It has large flour-mills and a considerable trade in corn. Pop. 6454.

Fernan'do de Noronha (no-ron'yá), a small island in the Atlantic, forming one of a small group of same name about 210 miles from the coast of Brazil, to which it belongs, and by which it is used as a penal settlement. It is defended by forts. The group is essentially volcanic in character; the vegetation of the tropical American type, remarkable for the immense number of creepers which festoon the trees. A scientific expedition was sent out by the British

government in July, 1887, to investigate the group.

Fernan'do Po, a Spanish island in the Bight of Biafra, off the west coast of Africa, about 20 miles from the mainland. It is of volcanic origin, and is of an oblong form, broadest at the south extremity, 35 miles long and 22 miles broad. It is traversed from north to south by a ridge of mountains terminating in a magnificent cone, 11,040 feet high, called Clarence Peak. The island is picturesquely covered with forests and luxuriant vegetation, chiefly palms and the bombax or silk-cotton tree. There are several harbours in the island. The population is about 20,000, partly a mixture of negroes, Portuguese, and other Europeans, partly native-born negroes. The capital is Clarence Town.

Ferney, a frontier village in France, dep. Ain, 1½ mile north of Geneva, celebrated as the chief residence of Voltaire from about 1760 to 1778. Pop. 1288.

Ferns (*Filices*), a natural order of cryptogamous or flowerless plants, forming the highest group of the acrogens or summit-growers. They are leafy plants, the leaves, or more properly fronds, arising from a rhizome or root-stock, or from a hollow arborescent trunk, and being circinate in veneration, a term descriptive of the manner in which the fronds are rolled up before they are developed in spring, having then the appearance of a bishop's crosier. On the veins of their lower surface, or their margins, the fronds bear small vessels named *sporangia*, containing spores. These spore-cases are arranged in clusters, named *sori*, which are either naked or covered with a layer of the epidermis, which forms an involucre or indusium. When the spores germinate they produce a cellular structure of a leafy description, called the *pro-embryo*, or *prothallus*, upon which are developed organs which have received the names of *antheridia* and *archegonia*. When produced upon the *prothallus* these organs do not immediately give origin to a germinating spore, but from their mutual action proceeds a distinct cellular body, destined at a later period to develop into a fruit-bearing frond. Ferns have a wide geographical range, but are most abundant in humid, temperate, and tropical regions. In the tropical forests the tree-ferns rival the palms, rising sometimes to a height of 50 or 60 feet. Ferns are very abundant as fossil plants. The earliest-known forms occur in Devonian

rocks. Various systems of classification for ferns have been proposed. At present the order is usually divided into six or eight sub-orders or tribes distinguished by differences in the structure of the sporangium. The generic characters are founded on the position and direction of the sori and on the venation. The largest division is that of the Polypodiaceæ, to which nearly all British ferns belong, such as the polypody, the lady-fern, the bracken, the hard-fern, the spleenwort, the maiden-hair, the hart's-tongue fern, &c. The royal fern, however, belongs to the Osmundaceæ. A few of the ferns are used medicinally, mostly as demulcents and astringents. Some yield food. *Pteris esculenta* is the edible bracken of New Zealand.

Ferozepoor. See *Firozpur*.

Ferra'ra, a city of N. Italy, capital of the province of same name, 26 miles N.N.E. Bologna, in a fertile but unhealthy plain. It is a well-built town with many remains of the splendour and commercial prosperity it enjoyed under the house of Este. Under the papal rule it fell into decay, and has now a deserted appearance. The old ducal castle or palace (now occupied by public offices), several other palaces, the cathedral, the public picture-gallery, the houses where Ariosto and Guarini lived, the cell in which Tasso was imprisoned, a monument to Savonarola, who was born here, are amongst the many interesting monuments which Ferrara contains. Pop. 28,814.—The province was formerly a duchy of Italy held by the House of Este as a papal fief from 1471 till 1597, when it fell to the pope. (See *Este*.) At the unification of Italy under Victor Emmanuel in 1860 it gave its name to a province bounded on the N. by the Po, E. by the Adriatic, S. and W. by Ravenna, Bologna, and Modena; area, 1100 square miles; population, 1891, 247,788.

Ferra'ri, GIUSEPPE, an Italian philosopher, born 1812 at Milan, studied law at Pavia, but afterwards devoted himself to literature. He first won notice by his edition of Vico's works (1836-37). Having gone to France he was professor of philosophy at Strasburg for a number of years. In 1859 he returned to Italy, becoming successively professor at Turin and Milan. He died at Rome in 1876. Amongst his principal writings are: *Essai sur le Principe et les Limites de la Philosophie de l'Histoire* (1847), *Filosofia della Rivoluzione* (1851), *Corso di Lezioni sugli Scrittori Politici Italiani* (1862).

Ferreira (fer-ā'i-rā), ANTONIO, Portuguese poet, born at Lisbon 1528. He carried to perfection the elegiac and epistolary style, and added to Portuguese poetry the epithalamium, the epigram, ode, and tragedy. His tragedy of Ines de Castro is still considered by the Portuguese as one of the finest monuments of their literature. He died 1569.

Fer'ret (*Putorius* or *Mustēla furo*), a carnivorous animal closely allied to the polecat,



Ferret (*Mustēla furo*).

about 14 inches in length, of a pale-yellow colour, with red eyes. It is a native of Africa, but has been introduced into Europe. It cannot, however, bear cold, and cannot subsist even in France except in a domestic state. Ferrets are used, in catching rabbits, to drive them out of their holes.

Fer'rier, JAMES FREDERICK, a Scotch metaphysician, born at Edinburgh in 1808, died at St. Andrews June 11, 1864. After studying at Edinburgh and Oxford he was admitted to the Scottish bar in 1832, but gave his attention more to literature than to law. His contributions to Blackwood's Magazine, then at the height of its fame, brought him into notice, and in 1845 he was appointed to the chair of moral philosophy at St. Andrews. His chief work is the Institutes of Metaphysic, in which he attempts to build up in a rigorously logical and deductive method a complete system of knowing and being.

Ferris Wheel, THE, exhibited at the Chicago World's Fair, was a remarkable engineering feature. Its diameter was 270 ft.; its circumference 825 ft. Its highest point was 280 ft. The axle was a steel bar, 45 ft. long, 32 inches thick. Fastened to each of the twin wheels was a steel hub 16 ft. in diameter. The 36 cars on the wheel each comfortably seated 40 persons, wheel and passengers weighing 1200 tons. The two

towers at the axis supporting the wheel were 140 ft. high. The motive power was a 1000-horse-power steam-engine under the wheel. By the Ferris wheel the almost indefinite application of the tension spoke to wheels of large dimensions has been vindicated, the expense being far smaller than that of the stiff spoke.

Ferro, or **HIERRO**, the most south-western and smallest of the Canary Islands, about 18 miles long and 9 miles broad. This island having once been supposed the most western point of the Old World, was formerly employed by all geographers to fix their first meridian, and the longitude reckoned from it. As first meridian its conventional place is 20° w. of Paris and 17° 40' w. of Greenwich. It is still occasionally used by German geographers.

Ferrocyanic Acid. See *Prussic Acid*.

Ferrol', a fortified seaport of Northern Spain, in the province and about 12 miles N.E. of the town of Coruña, on a fine inland bay, connected with the sea by a channel so narrow as to admit only one ship-of-the-line at a time. The chief naval arsenal of Spain, established on a magnificent scale, is here. The manufactures consist chiefly of



swords, cutlery, and military and naval equipments. Pop. 23,811.

Ferry, a particular part of a river, lake, arm of the sea, &c., where a boat or other conveyance plies to carry passengers or goods from the one side to the other. The right of establishing a public ferry is usually the prerogative of a government or legislature. The person who has a right of ferry is required to keep a boat or boats suitable for the conveyance of passengers, to charge

a reasonable fare, and to provide the requisite landing-places on either bank of the river. No one will be allowed to establish a rival ferry so near the original one as to destroy its custom. Common rowing-boats, sailing-boats, large flat-bottomed barges pulled along a rope stretched from bank to bank for horses and carriages, and steam-ferry-boats are among the conveyances.

Ferry, JULES FRANÇOIS CAMILLE, French statesman and writer, born at St. Dié in the Vosges April 5, 1832. He became a barrister at Paris, but devoted himself almost entirely to journalism. His articles in the *Presse*, *Courrier de Paris*, and *Temps*, from 1856 to 1869, brought him much into notice, and in 1869 he was returned as deputy for the sixth arrondissement of Paris and took his seat among the members of the 'Left.' After the fall of Sedan he became a member of the Government of the National Defence. In 1872 Thiers appointed him minister-resident at Athens. In 1879. he became minister of public instruction, and as such introduced an education bill, which amongst other things forbade unauthorized communities, such as Jesuits, to teach in schools. In 1880, Ferry, having become premier, entered upon a vigorous and somewhat hazardous foreign policy. His seizure of Tunis in 1881 was so far successful, though it led to his resignation; again premier in 1883 his unfortunate expedition to Tonquin forced him to retire from office. Feb. 24, 1893, he was elected president of the senate, but died March 17 of the same year.

Ferté-sous-Jouarre (fer-tā-sö-zhö-är), a town of France, department of Seine-et-Marne, 37 miles E.N.E. of Paris. Pop. 4804.

Ferti'ization of Plants. See *Botany*.

Ferti'lizers, the name given to various manures (which see).

Fer'ula, a genus of umbelliferous plants, whose species often yield a powerful stimulating gum resin, employed in medicine. The species are natives of the shores of the Mediterranean and Persia, and are characterized by tall-growing pithy stems, and deeply-divided leaves, the segments of which are frequently linear. *F. communis* of English gardens is called giant fennel. *F. orientālis* and *F. tingitāna* are said to yield African ammoniacum, a gum resin like asafetida, but less powerful.

Fescen'nine Verses, rude Latin verses in the form of a dialogue between two persons, who satirized and ridiculed each other's fail-

ings and vices with great freedom of speech. They originated in country districts in ancient Italy, but were ultimately introduced into the towns, and formed a favourite amusement at marriages and on other occasions of festivity.

Fesch (fesh), JOSEPH, half-brother of Napoleon's mother, was born at Ajaccio in 1763. He had devoted himself to an ecclesiastical life, but quitted it on the outbreak of the French revolution, and became commissary of war to the army of the Alps. After the restoration of Catholic worship he resumed his ecclesiastical status and became in 1802 Archbishop of Lyons, and next year a cardinal. After the fall of Napoleon he retired to Rome, where he died in 1839.

Fes'cue, the popular name of a genus of grasses (*Festūca*) belonging to the division with many-flowered spikelets on long stalks. Amongst the numerous species are some of the most valuable meadow and pasture grasses of Britain. *F. pratensis*, or meadow fescue, and *F. duriuscūla*, or hard fescue, are both highly prized for agricultural purposes. *F. ovīna*, or sheep's fescue, is much smaller than either of these, and is useful for lawns. It is abundant in mountain pastures. *F. elatior*, the tall fescue, is a coarse reedy grass with stem usually 4 or 5 feet high. All these species are perennial.

Fesse (fes), in heraldry, a band or girdle comprising the centre third part of the shield, and formed by two horizontal lines drawn across

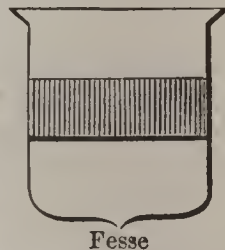

it; it is one of the nine honourable ordinaries. The fesse-point is the exact centre of the escutcheon.

Festiniog, a town of N. Wales in Merioneth, with important slate quarries. Pop. 8000.

Fes'tivals, or FEASTS, certain days or longer periods consecrated to particular celebrations either in honour of some god, or in commemoration of some important event. Such festivals have prevailed among nearly all nations, both ancient and modern. Amongst the Jews there are six festivals prescribed in the Scriptures (Lev. xxiii.), and thence called sacred feasts. These are the weekly feast of the Sabbath; the Passover, or Feast of Unleavened Bread; Pentecost, or the Feast of Weeks; the Feast of Trumpets, or New Moon; the Feast of the Atonement; and the Feast of Tabernacles.

Afterwards the Feast of Purim (to commemorate the failure of Haman's machinations), and the Dedication of the Temple (after its profanation by Antiochus Epiphanes), were added. Amongst the ancient Greeks were celebrated the Dionysia; the Eleusiania; the four great national games, the Olympic, the Isthmian, Nemean, and Pythian games. But each community and city had its own local festivals in addition, such as the Panathenæa, held by the tribes of Attica, whose union it was intended to celebrate. Among Roman festivals were the Saturnalia, Cerealia, Lupercalia, and others.

The festivals of the Christian church owe their origin partly to those of the Jewish religion, such as Easter, which corresponds to the Passover of the Jews, and Whitsuntide, which corresponds to Pentecost; partly also to pagan festivals, which the Christian hierarchy, finding it impossible to abolish them, applied to Christian uses by converting them into festivals of the church. These festivals are divided into movable and immovable; the former those which in different years fall on different days, the latter those which always fall upon the same day. The chief of the movable feasts is Easter, the one on which the position of all the others, except that of Advent Sunday, depends. (See *Easter*.) Septuagesima Sunday falls nine weeks before Easter, Sexagesima Sunday eight weeks, Quinquagesima Sunday seven weeks, the first Sunday in Lent six weeks, and Palm Sunday one week before Easter. Rogation Sunday falls five weeks, Ascension Day forty days, Whitsunday seven weeks, and Trinity Sunday eight weeks after Easter. Ash Wednesday is the Wednesday before the first Sunday in Lent, Maundy Thursday the Thursday, and Good Friday the Friday before Easter, and Corpus Christi is the Thursday after Trinity Sunday. Advent Sunday is the nearest Sunday to the feast of St. Andrew, November 30, whether before or after. The chief immovable feasts are the feast of the Circumcision on the 1st of January, Epiphany on the 6th of January, the Annunciation of the Blessed Virgin on the 25th of March, the Transfiguration of Christ on the 6th of August; the feast of St. Michael (Michaelmas) and All the Angels on the 29th of September, the feast of All-Saints on the 1st of November, the festival of All-Souls on the 2d of November, and Christmas Day or the Feast of the

Nativity of our Lord on the 25th of December. The festivals relating to the Virgin Mary in the R. Catholic Church include: the feast of the Annunciation; the Purification of the Virgin, or Candlemas; the feast of the Visitation of Our Lady; the feast of the Immaculate Conception; the Nativity of the Virgin; the Martyrdom of the Virgin Mary; the Assumption of the Virgin (Aug. 6); and several smaller ones. The worship of the cross introduced two festivals: that of the Invention of the Holy Cross (May 3), and that of the Exaltation of the Cross (September 1). The saints' days that are still held as festivals, and have religious services connected with them in the Church of England, are called *red-letter* days, because they used to be printed with red letters in the church calendar; while the saints' days which were still retained in the calendar at the Reformation, but had no services connected with them, are called *black-letter* days, because they were printed in black letters.

Festoon', in architecture, same as *Encarpus*.

Festus, PORCIUS, Roman procurator of Judæa 61–62 A.D., successor of Felix. The apostle Paul appeared before him, and was sent by him to Rome at his own request.

Festus, SEXTUS POMPEIUS, a Roman grammarian belonging to the 2d or 3d century of our era, author of an abridgment of a work by Verrius Flaccus called *De Verborum Significatione*, a kind of dictionary, which is very valuable for the information it contains about the Latin language. The work of Festus was still further abridged in the 8th century by Paulus Diaconus. The one MS. of the original work of Festus is now at Naples.

Fétis (fā-tēs), FRANÇOIS JOSEPH, a Belgian musical composer and writer on music, born 1784, died 1871. He was educated at the Paris Conservatoire; was professor there from 1818 to 1833, when he was appointed director of the Conservatoire at Brussels. Among his works may be mentioned *Traité de la Fugue* (1825); *Biographie Universelle des Musiciens* (1835–44); *Traité Complet de la Théorie et de la Pratique de l'Harmonie*. His musical compositions include operas, sacred music, and instrumental pieces for the piano and the violin.

Fe'tish, or FETICH, a word first brought into use by De Brosses, in his work *Du Culte des Dieux Fétiches* (1760), and derived from the Portuguese *feitico*, magic, a

word which expressed the Portuguese opinion of the religion of the natives of the west coast of Africa. The Portuguese gave this name to the idols of the negroes of the Senegal, and afterwards the word received a more extensive meaning. A fetish is any object which is regarded with a feeling of awe, as having mysterious powers residing in it, but without any consciousness in the exercise of them. The fetish may be animate, as a cock, a serpent, &c.; or inanimate, as a river, a tooth, a shell. Fetish worship prevails in Guinea and other parts of the west coast of Africa. In addition to the common fetish of the tribe every individual may have one of his own. To this he offers up prayers, and if they are not heard he punishes it, or perhaps throws it away, or breaks it in pieces.

Fetus, FÆTUS, the young of viviparous animals in the womb, and of oviparous animals in the egg, after it is perfectly formed; before which time it is called *embryo*.

Feu, FEU-HOLDING, in Scottish law, in its widest sense signifies any tenure of land which constitutes a relation of superior and vassal. The term is now, however, restricted to a special kind of tenure by which usually a small piece of ground is held perpetually from a superior on payment of an annual sum.

Feudal System, that system by which land (a *fief*) is held by a vassal on condition of fidelity, that is, in consideration of services to be rendered to his superior or feudal lord. The nature of the feudal system is to be explained by its origin amongst the Germanic tribes. In the earliest times the relation of superior and vassal did not exist in connection with the ownership of land. Each freeman had his share of the tribe lands, which were held simply on condition of his fulfilling his public duties of attendance at the councils of the mark or township and performing his share of military service in the wars or musters decreed at such councils. The noble had, of course, more land and more influence than the simple freeman, but there need be no tie of vassalage between them. This seems to have been the primitive social organization of the Anglo-Saxons and other German tribes. The lands held by all freemen, whether noble or ordinary freemen, under this system, are said to be *allodial*, as distinguished from *feudal* lands, which imply service to a superior lord. By the close of the 10th century, however, this system had

undergone considerable modifications. The masses of Teutonic invaders who overran Gaul and England had necessarily to confer exceptional powers on their leaders; and as they were for long very much in the position of military in an enemy's country, these powers were naturally continued. Thus it was that kings, before unknown to the Anglo-Saxons, make their appearance immediately after their descent upon Britain. It was common for a chief or great man to have a retinue or body-guard composed of valiant youths, who were furnished by the chief with arms and provisions, and who in return devoted themselves to his service. These companions (Anglo-Saxon, *Gesithas*; German, *Gesellen*) originally received no pay except their arms, horses, and provisions, and the portion of the spoils which remained after the chieftain had taken his own share. But when conquered lands came to be apportioned and large districts fell into the hands of kings or dukes and their subordinates, they gave certain portions of the territory to their attendants to enjoy for life. These estates were called *beneficia* or fiefs, because they were only lent to their possessors, to revert after their death to the grantor, who immediately gave them to another of his servants on the same terms. As the son commonly esteemed it his duty, or was forced by necessity, to devote his arm to the lord in whose service his father had lived, he also received his father's fief; or rather, he was invested with it anew. By the usage of centuries this custom became a right and the fief became hereditary. A fief rendered vacant by the death of the holder was at once taken possession of by his son, on the sole condition of paying homage to the feudal superior. Thus a feudal nobility and a feudal system arose and for a time existed alongside of the old allodial system. But gradually the greater security to be got by putting one's self under the protection of some powerful ruler or leader gave the feudal system the predominance. The free proprietor of landed property, oppressed by powerful neighbours, sought refuge in submitting to some more powerful nobleman, to whom he surrendered his land, receiving it back as a vassal. Even the inferior nobility found it to be to their advantage to have themselves recognized as feudatories of the nearest duke or earl; and as the royal power steadily advanced, the offices of duke, ealdorman, gerefa, &c., were always bestowed by the king. Thus the crown

became the source of all authority and possession in the country. The land which had once been 'folcland,' or the land of the people, became the land of the king, from whom all titles to it were held to be derived. Such at least was the development of feudalism in England, where its centralizing tendencies, especially in the matter of holding land from the crown, were strongly reinforced by the circumstances of the conquest under William the Norman. Under him and his immediate successors there was a struggle between royalty and the nobility, which ended in the power of the latter sinking before that of the kings. On the other hand, in Germany, France, and elsewhere on the Continent, the disintegrating tendencies of feudalism as a system of government had full play. In these countries the weakening of the kingly authority encouraged the great feudal dukes and counts to set up in an almost absolute independence, which in France was afterwards gradually lost as the monarchy grew stronger, but in Germany continued to divide the land down almost to our own times into a number of petty principalities.

Among the chief agencies that overthrew the feudal system were the rise of cities, the change in modes of warfare, and the spread of knowledge and civilization. The spirit of the feudal system, grounded on the prevalence of landed property, was necessarily foreign to cities which owed their origin to industry and personal property, and founded thereon a new sort of power. The growth of this new class, with its wealth and industrial importance, has contributed more than anything else to a social and political development before which the old feudal relations of society have almost totally disappeared. Even yet, however, the laws relating to land still bear the stamp of feudalism in various countries. In England, for instance, all land-owners are theoretically regarded as tenants holding from some superior or lord, though the lord may be quite unknown. See also *Middle Ages*.

Feuerbach (foi'èr-bâh), LUDWIG ANDREAS, a German metaphysician, son of the celebrated jurist (see next article), was born at Landshut in Bavaria in 1804. After studying theology and philosophy at Heidelberg and Berlin he became a tutor (Privatdocent) at Erlangen University in 1828. As his negative views in theology were obnoxious to government, and thus deprived him of all chance of a professor-

ship, he resigned, and the latter part of his life was passed in straitened circumstances. He died in 1872. All transcendental ideas, such as God, immortality, &c., Feuerbach came to regard as deleterious illusions, and considered that the direct contact of the senses with things alone gave the full truth. His works include a Critique of Hegel (1839); The Essence of Christianity (1841; translated by George Eliot, 1854); The Essence of Religion (1849); Godhead, Freedom, and Immortality (1866).

Feuerbach, PAUL JOHANN ANSELM, German criminal jurist, was born at Jena in 1775. Having published his first work, entitled *Anti-Hobbes*, in 1798, he began in 1799 to deliver lectures on law at Jena as Privatdocent. In 1801 he became an ordinary professor of jurisprudence at Jena, but the following year accepted a chair at Kiel. In 1804 he obtained an appointment in the University of Landshut, where he was employed to draw up the plan of a criminal code for Bavaria, which received the royal assent in 1813. In 1814 he was appointed second president of the appeal court at Bamberg, and in 1817 first president of the appeal court for the circle of Rezat at Anspach. He died in 1833. Among his most interesting and important works are *Remarkable Criminal Trials*, and *Themis*, or *Contributions to the art of Law-making*.

Feuillants (feu-yän), a religious order which arose as a reform of the order of Bernardines, and took origin in the abbey of Feuillants, near Toulouse, established in 1577. There were also convents of nuns who followed the same reform, called *Feuillantines*. They were suppressed by the revolution of 1789, and their convent in Paris taken possession of by a political club named the Feuillants, of which Mirabeau was a member.

Feuille (feu-yā), OCTAVE, a French novelist and dramatist, born at Saint Lô, department of Manche, 11th Aug. 1812, came into notice about 1846 with his novels of *Le Fruit Défendu*, *Le Conte de Polichinelle*, and a series of comedies and tales which were published in the *Revue des deux Mondes*. In 1857 the appearance of *Le Roman d'un Jeune Homme Pauvre* raised Feuille to the first rank of the novelists of the day. Amongst his other numerous novels are *Monsieur de Camors* (1867), *Julia de Trécœur* (1872), *Le Sphinx* (1874), *Histoire d'une Parisienne* (1881), &c. His works have a refined humour, and are free,

in great part, from the realistic coarseness of the later French school. Died 1890.

Feuilleton (*feu-i-ton*), that part of a French newspaper devoted to light literature or criticism, and generally marked off from the rest of the page by a line. The feuilleton very commonly contains a tale.

Fever (Latin, *febris*), a diseased condition of the body characterized by an accelerated pulse, with increase of heat, deranged functions, diminished strength, and often with excessive thirst. Fevers usually commence with chills or rigors, known as the *cold stage* of the disease, although the temperature of the body is really increased. There are also a feeling of lassitude, pains in the back and limbs, loss of appetite, and nausea. This soon develops into the *hot stage*, in which the pulse quickens and the skin becomes hot and dry. These phenomena are accompanied by thirst, headache, a furred tongue, a constipated state of the bowels, and a deficiency in the urinary secretion. The symptoms are generally aggravated at night, and may even be accompanied by slight delirium. After a time the *crisis* is reached, when the patient either dies from gradual exhaustion or from hyperpyrexia, or he begins to recover, the febrile symptoms disappearing sometimes quite suddenly, sometimes very slowly. The loss of strength in fever due to the waste of tissue (caused by the abnormal temperature) being greatly in excess of the nutritive supply, together with the general disturbance of functions, often brings about fatal results. In many cases fever is only an accompanying symptom of some specific disorder, but in others it is the primary and predominant element, apparently due to some poison operating in the blood. (See *Germ Theory of Disease*.) These primary or specific fevers may be classified as follows:—

1. *Continued Fever*, in which there is no intermission of the febrile symptoms till the crisis is reached. Simple fever, or febricula, typhus, typhoid (enteric or gastric) fever are examples. *Relapsing fever* also comes under this head; its chief feature is the recurrence of fever about a week after the subsidence of the symptoms.

2. *Intermittent Fever* or *Ague*, in which there is a periodic cessation of the symptoms. The varieties are the *quotidian*, occurring every day; the *tertian*, recurring in 48 hours; *quartan*, recurring in 72 hours or every three days.

3. *Remittent Fever*, in which there is a

short daily diminution of the symptoms. The condition known as hectic fever and yellow fever belong to this class.

4. *Eruptive Fevers*—(1) Small-pox. (2) Cow-pox. (3) Chicken-pox. (4) Measles. (5) Scarlet-fever. (6) Erysipelas. (7) Plague. (8) Dengue fever. See the separate articles.

Fe'verfew (*Pyrethrum Parthenium* or *Matricaria Parthenium*), a common composite biennial, frequent in waste places and near hedges. It has a tapering root, an erect, branching stem about 2 feet high, and stalked compound leaves of a hoary green colour, and ovate cut leaflets. The plant possesses tonic and bitter qualities, and was supposed to be a valuable febrifuge, whence its name.

Fez, one of the two capitals of Marocco, 100 miles east of the Atlantic and 85 miles south of the Mediterranean. It is finely situated on the hilly slopes of a valley, on the river Fez, which divides Old Fez from New Fez. Both parts are surrounded by walls now in very bad repair. The streets are narrow, dark, and extremely dirty; the houses two or three stories high, and without windows to the street. The interiors, however, are often handsome, the courtyards being paved and provided with fountains. There are many mosques, one of them the largest in N. Africa. The sultan's palace is a large but somewhat ruinous structure. Fez is a place of considerable commercial importance, being the depot for the caravan trade from the south and east and having extensive dealings with Europe. The manufactures consist of woollen cloaks, silk handkerchiefs, leather, the red caps named *fezes*, carpets, pottery, &c. Fez was at one time famous as a seat of Arabian learning. It is considered a holy town by the Western Arabs, and was resorted to by them as a place of pilgrimage when the way to Mecca was obstructed. Fez was founded in 793, and was the capital of an independent state from 1202 to 1548, attaining a high state of prosperity. The population is variously estimated from 50,000 to 150,000.

Fez (from *Fez*, the above town), a red cap of fine cloth, with a tassel of blue silk or wool at the crown, much worn in Turkey, on the shores of the Levant, in Egypt, and North Africa generally. The core or central part of a turban usually consists of a fez.

Fezzan', a state of North Africa, in the Sahara, forming a depression surrounded by mountain chains and consisting of a great number of small oases. There are no rivers

or brooks, and few natural springs; but water is found in abundance at various depths, generally from 10 to 20 feet. Rain seldom falls; in some districts it does not rain for years together, and but little at a time. Wheat, barley, millet, figs, melons, and other fruits, tobacco, cotton, &c., are cultivated, but the chief wealth of the country is in its date-palms. With exception of goats and camels, and in some districts sheep and cattle, few domestic animals are reared. There are few manufactures, but there is a considerable caravan trade, especially in slaves, Mourzuk, the capital, being the point of junction for caravans from Timbuctoo, Cairo, Tripoli, Soudan, &c. The natives are a mixed race of Arabs, Berbers, negroes, &c. Fezzan is governed by a lieutenant-governor (Kaïmakam) under the governor of Tripoli, and dependent therefore on Turkey. Pop., variously estimated, does not probably exceed 50,000.

Fiacre (fē-ä-kr), in France, a small four-wheeled carriage or hackney-coach, so called from the Hotel St. *Fiacre*, where Sauvage, the inventor of these carriages, established in 1640 an office for the hire of them.

Fiars' Prices, or **FIARS** (fē'arz), in Scotland, the prices of grain for the current year in the different counties, fixed by the sheriffs with the assistance of juries, and accepted in certain contracts or agreements where no price has been fixed otherwise.

Fi'at (Lat. 'let it be done'), in English law, a short order or warrant from a judge for making out and allowing certain processes.

Fibres used in Manufacture. These may be of mineral, animal, or vegetable origin. In the mineral kingdom a fibre which may be so used has been found in asbestos (which see). Amongst animal fibres the silk obtained from the cocoons of the silk-worm and the wool of the sheep represent two great classes. (See *Silk* and *Wool*.) Of the latter the wool of the sheep is by far the most important on account of its length, its fineness, and the comparative ease with which it can be produced in large quantities for the market. Amongst other animals whose wool or hair is also used to some extent are the goat, especially of the Angora species, the llama or alpaca, the vicuña, the rabbit, the yak, the chinchilla, &c. But the vegetable kingdom furnishes by far the greatest number and variety of fibres for manufacturing purposes. These fibres are obtained either, as in exogenous plants, from the sheath of the bark or bast; or, as in en-

dogenous plants, from the cellular tissues and pulp of their roots, stems, and leaves; or, in a few plants, from a hairy covering which grows upon the seeds within the pod. Of the first class are flax, from the fibres of the *Linum usitatissimum*; hemp, from the *Cannābis satīva*, a plant of the nettle family; jute, from several species of *Corchōrus*, a plant of the linden family; China grass from the *Boehmeria nivea*, &c. To the second class belong New Zealand flax, from the leaves of the *Phormium tenax*; Manilla hemp, from the leaf-stalks of the *Musa textilis*; coir of cocoa-nut fibre, from the husk of the cocoa-nut; Pita-flax, the fibre of the leaves of the *Agāve americana*, &c. To the third class belong cotton, from the seed-hairs of *Gossypium*; vegetable silk, the fibres which grow upon the seeds of the Asclepiadaceæ, &c. For details see *Cotton*, *Flax*, *Hemp*, *Jute*, *Silk*, *Wool*, &c.

Fi'brin, a peculiar organic compound substance found in animals and vegetables. Animal fibrin constitutes the solid matter which deposits when blood coagulates, but it is also furnished by the chyle, lymph, saliva, and by pus and other pathological fluids. Fibrin is composed of carbon, nitrogen, hydrogen, and oxygen, and is closely allied to albumen and caseine. It is a very important element of nutrition. In healthy venous blood there is about 2·3 present, but its percentage is slightly more in arterial blood. It is best obtained by switching newly-drawn blood with a glass rod or bundle of twigs, when the fibrin adheres to the rod or twigs in threads, and is purified from colouring matter by prolonged washing and kneading with water, and then by treatment with alcohol and ether to remove fat and other substances.

Fibrous Tissue, an animal tissue with a shining silvery lustre used to connect or support other parts. It is of two kinds, white, and yellow (elastic). It forms the ligaments, tendons of muscles, &c.

Fib'ula, in anat. the outer and smaller bone of the leg below the knee, much smaller than the tibia. See *Leg*.

Fichte (fih'tè), JOHANN GOTTLIEB, German philosopher, born of poor parents in 1762. After studying at Jena, Leipzig, and Wittenberg he passed several years as a private tutor in Switzerland and in Prussia Proper, and in Königsberg made the acquaintance of the great Kant, who showed some appreciation of his talents. His *Versuch einer Kritik aller Offenbarung* (Essay towards a

Criticism of all Revelation, 1792) attracted general attention, and procured him the professorship of philosophy in Jena in 1793. In 1800 he was one of the most prominent professors of that university during its most brilliant period. Here he published, under the name of *Wissenschaftslehre* (Theory of Science), a philosophical system, which, though founded on Kant's system, gives the latter a highly idealistic development which was strongly repudiated by the Königsberg philosopher. On account of an article he had written to the *Philosophical Journal* (on the grounds of our belief in the divine government of the world) he fell under the suspicion of atheistical views. This gave rise to an inquiry, which ended in Fichte losing his chair. He then went to Prussia, where he was appointed in 1805 professor of philosophy at Erlangen. During the war between Prussia and France he went to Königsberg, where he delivered lectures for a short time, returned to Berlin after the Peace of Tilsit, and in 1810, on the establishment of the university in that city, was appointed rector and professor of philosophy. Fichte's philosophy, though there are two distinct periods to be distinguished in it, is a consistent idealism, representing all that the individual perceives as distinct from himself, the *ego*, as a creation of this *I* or *ego*. This *ego*, however, is not the consciousness of the individual so much as the divine or universal consciousness of which the other is but a part. His philosophy thus came to assume a strongly moral and religious character. He died on Jan. 27, 1814. Amongst his best-known works, besides those already mentioned, are: *System der Sittenlehre* (Systematic Ethics), *Die Bestimmung des Menschen* (The Destination of Man), *Das Wesen des Gelehrten* (The Nature of the Scholar), *Grundzüge des Gegenwärtigen Zeitalters* (Characteristics of the Present Age), *Reden an die Deutsche Nation* (Addresses to the German Nation).

Fichtelgebirge (fi'h'tel-ge-bir-ge), a mountain range of Germany, in Bavaria; chief summit, Schneeberg, 3460 feet.

Ficino (fi-chē'nō), MARSILIO, an Italian philosopher of the Platonic school, born at Florence in 1433. His early display of talent attracted the notice of Cosmo de' Medici, who caused him to be instructed in the ancient languages and philosophy, and employed him to aid in establishing a Platonic Academy at Florence (about 1460). Ficino amply satisfied his patron, and many

excellent scholars were formed under his tuition. His exposition of Plato suffers from his confounding the doctrines of Plato and those of Neo-Platonism. He died in 1499.

Fiction. See *Novel* and *Romance*.

Fiction, in law, is an assumption made for the purposes of justice, though the same fact could not be proved, and may be literally untrue. Thus an heir is held to be the same person as the ancestor to the effect of making the heir liable for the debts of the ancestor. The rules by which the existence of legal fictions are limited have been stated as follows: (1) The fiction must have the semblance of truth. (2) It shall not be used to work a wrong. (3) It shall only be employed for the end for which it was introduced.

Fi'cus, the fig genus of plants. See *Fig*.

Fiddle. See *Violin*.

Fiddle-fish. See *Angel-fish*.

Fiddle-wood, the common name of *Citharoxylon*, a genus of trees or shrubs with some twenty species, natives of tropical America, nat. order Verbenaceæ. Some of the species are ornamental timber trees; several yield a hard wood valuable for carpenter work.

Fief (fēf). See *Fee*, *Feudalism*.

Field, in heraldry, the whole surface of the shield on which the charges are depicted, or of each separate coat when the shield contains quarterings.

Field, CYRUS WEST, an American merchant, born 1819. Having obtained a charter giving him exclusive right for fifty years of landing ocean telegraphs on the coast of Newfoundland, he organized an Atlantic telegraph company. Attempts to lay cables were made in 1857 and 1858, but without permanent success, and the American war having broken out, it was not till 1866 that a cable was successfully laid by the *Great Eastern*. Mr. Field took an active part in establishing telegraphic communication with the West Indies, South America &c., and was connected with various important enterprises. He died July 12, 1892.

Field-allowance, an extra payment made to officers of the British army on active service in the field, to compensate partly the enhanced price of all necessaries. These allowances are not made in India.

Field-artillery, light ordnance easy of draught, and hence fitted for rapid movements in the field.

Field-cricket, *Achēta* (*Gryllus*) *campestris*, one of the most noisy of all the crickets,

larger, but rarer than the house-cricket. It frequents hot, sandy districts, in which it burrows to the depth of 6 to 12 inches, and sits at the mouth of the hole watching for prey, which consists of insects.

Field, DAVID DUDLEY, lawyer, was born in Haddam, Conn., Feb. 13, 1805. He has been especially prominent in the cause of law reform. It has been asserted that Mr. Field has done more for the reform of laws than any other man living.

Field-fortification, FIELD-WORKS, temporary works, such as trenches, rifle-pits, &c., thrown up to strengthen the position of an army operating in the field. See *Fortification*.

Field-glass, a binocular telescope in compact form, usually from 4 to 6 inches long. The name is also given to a small achromatic telescope usually from 20 to 24 inches long, and having from three to six joints.

Fielding, ANTHONY VANDYKE COPLEY, English painter in water-colours, born about 1787. He early attracted attention by his water-colour landscapes, and for fourteen years before his death was president of the Society of Painters in Water-colours. His pictures are chiefly taken from English scenery, the various features of which, both in rich woodland and open plain, he has represented with great delicacy and truth, although latterly falling into mannerism and self-repetition. His oil-painting was not a success. He died in 1855.

Fielding, HENRY, one of the greatest of English novelists, was born at Sharpham Park, in Somersetshire, the seat of his father, General Edmund Fielding (a member of the Denbigh family), April 22, 1707. He was educated at Eton, whence he removed to Leyden; but the straitened circumstances of his father shortened his academical studies, and the same cause, added to a dissipated disposition, turned his attention to the stage. His first dramatic piece was entitled *Love in Several Masks*, was produced at Drury Lane in 1728, and met with a favourable reception. *The Temple Beau*, *The Author's Farce*, *The Modern Husband*, *Don Quixote in England*, and many others quickly followed, a number of them being little more than free translations from the French. He himself became a stage-manager, and for some time conducted the Haymarket Theatre. About 1736 or 1737 he married Miss Craddock, a lady of some fortune, and at the same time, by the death of his mother, became possessed of a small estate in Dor-

setshire. He immediately commenced country gentleman on a scale which, in three years, reduced him to greater indigence than ever, with a young family to support. He then, for the first time, dedicated himself to the bar as a profession, and for immediate subsistence employed his pen on various miscellaneous subjects. *The Champion*, a periodical paper on the model of the *Spectator*, but written in a freer style, and *An Essay on the Knowledge and Characters of Men*, were among the early fruits of his literary industry. In 1740 he was called to the bar, and went on circuit, but with so little success that he was compelled to return to literature. In 1742 the first of his great novels, *Joseph Andrews*, appeared, which he had at first conceived as a burlesque of Richardson's *Pamela*. It was a great success, and was followed by *A Journey from this World to the Next*, and the *History of Jonathan Wild*. In 1749 he was appointed a Middlesex justice, a not very reputable office, but which Fielding's honesty and earnest discharge of his duties did something to render more respectable. In the same year his masterpiece, *The History of Tom Jones*, appeared, and was followed two years afterwards by *Amelia*. At length, however, his constitution, exhausted both by hard work and reckless living, gave way, and in the June of 1754 he had to seek the milder climate of Lisbon, where he died 8th October of the same year. The chief merits of Fielding as a novelist are wit, humour, correct delineation of character, and knowledge of the human heart. He drew from a very varied experience of life, which he reproduced with an artistic realism entitling him to be considered, far more than Richardson, as the creator of the English novel.

Field-marshal, the highest military dignity in Britain, Germany, and other countries. In Britain the dignity is conferred by selection and enjoyed by but a very few officers, and chiefly for distinguished services or on the ground of royal descent. It was introduced into Britain by George II. in 1736.

Field-mouse. See *Mouse*.

Field-officers, in the army, those competent to command whole battalions—majors, lieutenant-colonels, colonels, as distinguished from those intrusted with company duties, as captains and lieutenants.

Field of the Cloth of Gold, a spot in the valley of Andren, between the English castle of Guisnes and the French castle of

Ardres, celebrated for the meeting (7th June, 1520) between Henry VIII. of England and Francis I. of France, attended by the flower of nobility of both nations. The diplomatic results were little or nothing, and the event is now memorable only as a grand historic parade.

Field-pieces, small cannons, from three to twelve-pounders, carried with an army.

Field-works. See *Fortification*.

Fi'eri Fa'cias, a judicial writ for enforcing judgment against the goods of a debtor. The term is commonly contracted *Fi. Fa.*

Fiery Cross, among the Scottish Highlanders, a cross of light wood, the extremities of which were set fire to and then extinguished in the blood of a goat, sent from place to place as a summons to arms. Also known as the *Crantara*.

Fieschi (fi-es'kē), JOSEPH MARIE, conspirator, born at Murato in Corsica in 1790. He served for some years in the French army, and in the Neapolitan army of Murat. Having returned to his native land he was convicted of robbery and sentenced to ten years' imprisonment. After the revolution of 1830 he appeared in Paris and by means of forged papers obtained a small pension and an appointment under the pretence that he had been a victim of the Restoration. Being afterwards deprived of his appointment he resolved to avenge the slight by assassinating Louis-Philippe, which he attempted by an 'infernal machine' on 28th July, 1835. The king escaped with a slight scratch, although a number of persons around him were killed. Fieschi was guillotined Feb. 19, 1836, along with two of his accomplices.

Fiesole (fi-es'o-lā; anciently *Fasulæ*), a small town of Italy, 3 miles north-east of Florence, on the top of a steep hill. It has a cathedral and is the seat of a bishop. Anciently it was an important Etruscan city, and still has some Etruscan remains. Pop. about 2800.

Fiesole, FRA GIOVANNI DA. See *Fra Angelico*.

Fife, a small instrument of the flute kind, pierced with six finger-holes, and usually having one key. Its ordinary compass is two octaves from D on the fourth line of the treble staff upwards. A combination of fifes and drums is the officially recognized music in the British army and navy.

Fife, or FIFESHIRE, a maritime county, Scotland, forming the peninsula between the

Firths of Forth and Tay; extreme length, 43 miles; extreme breadth, 17 miles; area, 316,089 acres. The surface is pleasantly undulating. The principal elevations are the Lomond Hills, whose highest summit is 1720 feet above sea-level. The principal valley, called Strath Eden, or the 'Howe (hollow) of Fife,' watered by the Eden, is very fertile, highly cultivated, and thickly studded with beautiful mansions and villas. Very fertile also is the district lying along the shores of the Firth of Forth, and remarkable for the number of towns and villages with which it is lined. But the north-eastern part, between St. Andrews and the Tay, which is mostly a wet clayey soil, and the north-western part, mostly rock and moor, are in general cold and poor. Fife is the third largest coal-producing county in Scotland. Iron, limestone, and freestone abound. The chief manufacture of the county is linen, damasks, diapers, checks, ticks, &c.; the first two principally at Dunfermline, the last two at Kirkcaldy. There are salmon and other fisheries. The principal towns are Dunfermline, Kirkcaldy, St. Andrews, and Cupar, the county town. Fife returns two members to the House of Commons, being divided into an eastern and a western division. Pop. 1891, 187,320.

Fife Ness, the eastern extremity of Fife, about 2 miles from Crail. Near it is a dangerous ridge of rocks known as the Carr rocks, on which a beacon has been erected.

Fifth, in music, an interval consisting of three tones and a semitone. Except the octave it is the most perfect of concords. Its ratio is 3:2. It is called the fifth as it comes, by diatonic ascent, in the fifth place from the fundamental or tonic. See *Music*.

Fifth-monarchy Men; a sect of politico-religious enthusiasts who during the protectorate of Cromwell assumed to be 'subjects only of King Jesus.' They considered the revolution as the introduction to the *fifth* great monarchy which was to succeed to the four great kingdoms of Antichrist mentioned by Daniel (the Assyrian, the Persian, the Grecian, and the Roman), and during which Christ was to reign on earth 1000 years.

Fig (*Ficus Carica*), a deciduous tree belonging to the order Moraceæ (mulberry). It is indigenous to Asia Minor, but has been naturalized in all the countries round the Mediterranean. It grows from 15 to 20 or even 30 feet high. In congenial climates it

bears two crops in a season, one in the early summer from the buds of the last year; the other (which is the chief harvest) in the autumn, from those on the spring growth. The fruit is a hollow receptacle produced in the axils of the leaves on small round peduncles, and containing a great multitude of minute flowers, the ripe carpels of which are embedded in the pulp. The flowers are



Fig (*Ficus Carica*).—a, Fruit shown in section.

male and female, the former situated near the orifice at the top, the latter in that part of the concavity next the stalk. Figs, particularly dried figs, form an important article of food in the countries of the Levant. The best come from Turkey.

Fig'aro, a dramatic character first introduced on the French stage by Beaumarchais in his comedies, the *Barber of Seville* and the *Marriage of Figaro*. Figaro is a barber remarkable for his shrewdness and dexterity in intrigue. The plays were adapted for Mozart's *Marriage of Figaro* and Rossini's *Barber of Seville*. The name is also well known as that of satirical journals published in Paris and London.

Figéac (fē-zhāk), a town of France, department Lot, 42 miles E.N.E. of Cahors. It is an ancient place, and consists chiefly of narrow crooked streets and antiquated houses with quaint Gothic fronts. Pop. 5782.

Fighting-fish (*Macropodus* or *Ctenops pugnax*), a small fish of the family Anabasiidæ (climbing perch), a native of the south-east of Asia, remarkable for its pugnacious propensities. In Siam these fishes are kept in glass globes, as we keep gold-fish, for the purpose of fighting, and an extravagant amount of gambling takes place about the result of the fights. When the fish is quiet

its colours are dull, but when it is irritated it glows with metallic splendour.

Figueras (fi-gā'räs), a town of Spain, in the province of and 21 miles N.N.E. of Gerona, near the French frontier, defended by a fortress reputed the strongest in Spain. Pop. 11,739.

Figuiér (fē-gi-ā), LOUIS, a French writer of popular works on science, born 1819, and latterly professor in the School of Pharmacy, Paris. Among his works are *Histoire du Merveilleux dans les Temps Modernes*; *L'Alchimie et les Alchimistes*; *Vies des Savants Illustre depuis l'Antiquité jusqu'au XIX Siècle*; *Les Grandes Inventions*; *Le Tableau de la Nature*; &c. Several of his works have been translated into English, including different sections of the one last mentioned. He died Nov. 9, 1894.

Figuline, a name given by mineralogists to potter's clay.

Fig'ural (or **FIGURATE**) **Numbers**, numbers formed by the terms of arithmetical series of all sorts, in which the first number is always unity. For example:—

I.—1,	2,	3,	4,	5,	6, &c.
II.—1,	3,	6,	10,	15,	21, &c.
III.—1,	4,	9,	16,	25,	36, &c.
IV.—1,	5,	12,	22,	35,	51, &c.

Those in the second row are called *triangular* numbers, because their units may be arranged in equilateral triangles; the members of the third row are called *square* numbers; those of the fourth *pentagonal*, &c.; and so there are also *hexagonal*, *heptagonal*, and, in general, *polygonal* numbers.

Figure-head, the ornamental figure or bust on the projecting part of a ship's stem, over the cutwater and immediately under the bowsprit.

Fig-worts, the common name of *Scrophularia*, and sometimes also applied to the Scrophulariaceæ, a large natural order of exogenous plants represented by the calceolaria, foxglove, veronica, &c.

Fiji, FEEJEE, or **VITI ISLANDS**, an island group, South Pacific Ocean, east of the New Hebrides, between lat. 15° 30' and 19° 30' S.; and lon. 177° E. and 178° W. The entire group, which was discovered by Tasman in 1643, comprises altogether 254 islands and islets, eighty of which are inhabited; total area about 8000 sq. miles. Two of the islands only are of large size, namely, Viti Levu, 90 miles long by 60 wide; and Vanua Levu, rather longer but much narrower and more irregular. Next to these come Tavuni and Kandavu. The islands are of vol-

canic origin, extremely fertile, and covered with a luxuriant foliage, especially on the east side. The peaks are usually basaltic cones or needles, some of which rise to the height of several thousand feet. The coasts are almost surrounded with coral reefs, and where the shore is not precipitous the beach is formed of fine coral sand. The cocoa-nut palm grows along the sea-coasts; the bread-fruit, banana, and pandanus are abundant; the orange, taro, yams, sweet-potato, and since the commencement of European settlements, maize, tobacco, and the sugar-cane are cultivated; timber trees, including the chestnut, are plentiful; sandal-wood is now scarce. The birds are wild ducks, pigeons, the domestic fowl, parrots and other tropical species. Except the stock introduced there are hardly any animals. Fish are plentiful. The natives inclose and cultivate their lands, the women performing most of the manual labour. The climate on the whole is healthy and agreeable for Europeans. The Fijians are a dark-coloured, frizzly-haired, bearded race of Melanesian extraction, although intermixed with the Polynesians of Tonga and Samoa. They are cleanly in their habits, and are generally regarded as superior to the Polynesians in intelligence. Their early character, however, was bad. Cannibalism was reduced to a system, and wives, children, and friends were often sacrificed to the fondness for human flesh. Cannibalism seems now to be abolished. This result has been due to the Christian missions, mostly Wesleyan, which have been very successful, most of the native population having become professed Christians. From 1866 onwards the influx of European settlers from New Zealand and the Australian colonies gradually brought the trade of Fiji into importance, and repeated applications were made to the British government both by the settlers and the king, Thakombau, to annex the islands. At length in 1874 this was done, and the Fiji Islands were made a crown colony, under a governor, assisted by an executive council and legislative assembly, both either officials or nominated by the governor. Native chiefs take part in the administration, the old customary law being still largely adhered to. Since the annexation the prosperity of the colony has been remarkable. The revenue is between £60,000 and £70,000; the imports in 1887 were £469,151; the exports, £281,080. The chief article of export is sugar; the next is copra, the dried kernels of the cocoa-

nut. The other important exports are cotton, molasses, coffee, &c. The demand for labour has led to the introduction of some 6000 coolies from India. In 1887 the population was 124,658. The Europeans number about 2000. The capital is Suva, on the south coast of Viti Levu. The island of Rotumah, to the north, was annexed to Fiji in 1881.

Filangieri (fi-làn-ji-ā'rē), GAETANO, Italian writer, born of a noble family in 1752. He studied law, and soon became distinguished in his profession by his learning and eloquence. His life was mainly devoted to a great work, *La Scienza della Legislazione* (The Science of Legislation), which was characterized by great fearlessness of speech in the advocacy of reforms, and was condemned by an ecclesiastical decree in 1784. Filangieri died in 1788.

Filbert, the fruit of a cultivated variety of *Corylus Avellāna* or hazel. See *Hazel*.

File, a bar of cast-steel with small sharp-edged elevations on its surface called teeth, the use of which is to cut into or abrade metals, wood, ivory, horn, &c. Files are of various shapes, as flat, half-round, three-sided, square, or round, and are generally thickest in the middle, while their teeth are of various degrees of fineness and of different forms. A file whose teeth are in parallel ridges only is called *single-cut* or *float-cut*. Such are mostly used for brass and copper. When there are two series of ridges crossing each other the file is *double-cut*, which is the file best suited for iron and steel. *Rasps* are files which have isolated sharp teeth separated by comparatively wide spaces, and are used chiefly for soft materials such as wood and horn. Each of these three classes of files is made in six different degrees of fineness, the coarsest being called *rough*, the next *middle*, followed by *bastard*, *second-cut*, *smooth*, and *superfine* or *deadsmooth*, each a degree finer than that which precedes it. Files are usually made with the hand, file-cutting machines not having been as yet perfectly successful on account of the delicacy of touch required in the work. The *blanks*, as the steel before it has teeth is called, are laid on the anvil and struck with the chisel, which rests obliquely on the blank, each blow raising a ridge or tooth. The strength of the blow depends on the hardness of the metal, and when one part is harder than another the workman alters his blows accordingly. When one side is covered with single cuts, if the file is to be

double cut he adds in the same manner a second series, crossing the others at a certain angle. In making fine files a good file-cutter will cut upwards of two hundred teeth within the space of an inch. The files, except those that are used for soft substances, are then hardened by heating them to a cherry-red colour and then dipping them in water. They are then finished by scouring and rubbing over with olive-oil and turpentine.

File, a row of soldiers ranged one behind another from front to rear. When a column is arranged two deep, a file is thus two men.

File-fish, a name given to certain fishes from their skins being granulated like a file; they constitute the genus *Balistes*. *B. capriscus*, a common inhabitant of the Mediterranean, has the power of inflating the sides of the abdomen at pleasure, and grows to the size of 2 feet. *B. aculeatus* is a native of the Indian and American seas.

Fil'ibusters, a name given to those adventurers, chiefly from the United States, who endeavoured to effect settlements on the Spanish islands and colonies in Central America. The term is of Spanish origin, but is ultimately from the English *fly-boat*, referring to the small fast-sailing vessels used by the buccaneers in the 17th century. Among the most noted of the filibusters was William Walker, who made three expeditions to Nicaragua (1855, 1857, 1860).

Filicaja (fi-li-kä'yä), VINCENZO DA, an Italian poet, born in 1642 at Florence of a noble family. The publication of his odes, sonnets, &c., in 1684 established Filicaja's fame as the first poet of his time in Italy. The Grand-duke of Tuscany appointed him governor of Volterra, and then of Pisa, in which posts he gained the esteem equally of people and sovereign. He died in 1707. Among his most successful poems are the Canzone to John Sobieski on the occasion of the relief of Vienna from the Turks, and the celebrated sonnet on Italy, imitated by Byron in the 4th canto of *Childe Harold*, stanzas 42, 43.

Filigree', a kind of ornamental open work in gold or silver, wrought delicately in the manner of little threads or grains, or of both intermixed. The art was practised by the Etruscans and the Greeks of the Byzantine empire. In the 17th century it was carried to great perfection in Italy, and silver filigree work is still largely manufactured in the south of Europe. Some of the eastern nations, especially the Chinese and Malays,

show great skill in the manufacture of silver filigree.

Filipo d'Argiro, SAN. Same as *Agira*.

Fillan, ST. Two saints of this name, who flourished in the 7th and 8th centuries, appear in the church calendars.—(1) ST. FILLAN, or FAOLAN, the leper, whose annual festival is the 20th June. His principal church in Scotland was at the lower end of Loch Earn, in Perthshire, where 'St. Fillan's Well' was long believed to have wonderful healing properties.—(2) ST. FILLAN, the abbot, the son of St. Kentigerna in Inchcailleach, in Loch Lomond, had his chief church also in Perthshire, in Strathfillan, the upper part of Glen Dochart. The silver head of this abbot's crozier, intrusted by King Robert Bruce to the Dewar family, is now in the Antiquarian Museum, Edinburgh.

Fillet, in arch., a small moulding, generally rectangular in section, and having the appearance of a narrow band, generally used to separate ornaments and mouldings.

Fillmore, MILLARD, thirteenth president of the United States, born 1800, died 1874. He began his political career in 1828; was member of congress in 1832, and in 1849 became Vice-president of the U.S. By the death of General Taylor, Fillmore was raised to the office of president, which he held with much acceptance till 1853.

Filtra'tion, the process of freeing a liquid from solid matter suspended in it by causing it to pass through some pervious substance or substances which catch and retain the solid matter. The materials of which a filter is composed must have pores or interstices sufficiently coarse to allow the passage of the liquid, and yet sufficiently fine to prevent the passage of any solid particles. On a small scale unsized paper is generally used; but on a large scale various kinds of stone, sand, gravel, powdered glass, clay, porous sulphur, preparations of iron, charcoal, cloth, felt, horse-hair, skins, silicated carbon, sponge, wood, wool, cane, capillary threads, &c., are all employed. In domestic filters the simplest forms are those

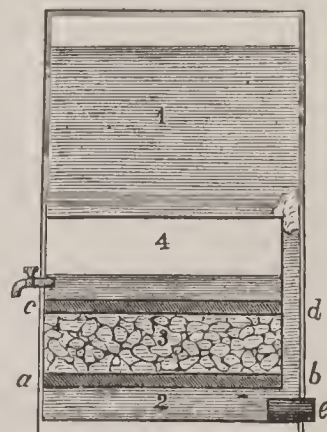

Leloge's Water Filter.

1234, The compartments: *a b*, porous top of 2d compartment; *c d*, filtering top of 3d compartment; *e*, movable plug.

in which the water passes down by its own gravitation through the filtering medium to a reservoir below. Lateral and ascending filtration are not uncommon. One of the most successful forms of ascending filter is divided into four compartments, as seen in the figure. The uppermost part, containing the water to be filtered, communicates with the lowest by a tube having a loose sponge at its mouth to stop some of the impurities. The top of the lowest compartment is composed of a porous slab, through which the water passes into the third part, which is filled with charcoal. The water is lastly forced through the charcoal and another slab into the remaining compartment, which is furnished with a tap to draw off the filtered water. The filters at water-works are large tanks or beds, made of good clay and filled with layers of large stones, pebbles, and coarse gravel, fine gravel, coarse sand and fine sand—the fine sand being at the top. Other materials are sometimes utilized, such as furnace cinders or clinkers, shells or shell-sand, and so forth. The water in the reservoir, collected from springs, surface drainage, and rain, is allowed to deposit its suspended matter in settling-tanks, and then it is run into the filters. By percolation the rest of the mineral matter is removed, and the water then flows into the mains which are to convey it to the locality where it is to be used. Filtration can only remove substances mechanically suspended in the liquid. In order to remove dissolved substances distillation is necessary.

Finale (fi-nä'le), the concluding part of a musical composition, for instance, of a quartette, of a symphony, of any act of an opera, of a ballet, &c. It consists of compositions of various characters.

Finance', the system or science of public revenue and expenditure. In the plural the term is applied to the income or revenue of a state, to the funds in the public treasury, and also to private income or resources. See such articles as *Exchequer*, *National Debt*, *Taxation*, *Bank*, &c.

Fin-back, or **FINNER**, a name given to the species of a genus of whales (*Physalus*), so called from their possessing a dorsal hump or fin. The name is also sometimes given to the members of the genus *Balenoptera* or rorquals.

Finch, one of the Fringillidæ, a large family of small seed-eating birds, inhabiting all parts of the globe, and belonging to the order Insectores, section Conirostres.

They are distinguished by having a sharply-pointed, conical, and in most cases a strongly-formed bill, suitable for crushing seeds and other hard objects. The species have been divided among several sub-families, as the haw-finches, the true finches, the buntings, the larks, the bull-finches, &c.

Finch, **HENEAGE**. See *Nottingham*, *Earlof*.

Fin'den, **WILLIAM**, line-engraver, born in 1787, died in London 1852. He engraved many illustrations for the Annuals and other books. In conjunction with his younger brother Edward and assistants he produced several extensive series of engravings of great merit; the first and most successful of which was *Illustrations of the Life and Works of Lord Byron*. Other series followed, including the *Royal Gallery of British Art*, 1838–40, a very important publication, the engravings in which measure $13\frac{1}{2} \times 9\frac{1}{2}$ in., and are of the highest class. The plates are executed by various engravers of the foremost rank. Besides his book-plates, Finden produced some celebrated large engravings, among which may be mentioned *The Village Festival* after Wilkie, George IV., full length seated on a sofa, after Sir Thomas Lawrence, &c.

Findlay, Hancock co., O., centre of natural gas industry. Pop. 18,553.

Find'horn, a Scotch salmon river which flows through the counties of Inverness, Nairn, and Elgin, and falls into the Moray Firth after a course of 62 miles.

Fin'don, or **FINNAN**, a fishing village, Kin-cardineshire, Scotland, 8 miles s. of Aberdeen, celebrated for its smoke-cured fish known as Findon or Finnan haddocks. Pop. 330.

Fine, in English law, formerly signified a sum of money paid at the entrance of a tenant into his land and on other occasions, but now generally has the signification of a pecuniary penalty exacted either in punishment of, or in compensation for, an offence, whether committed against an individual, in contravention of the laws of the community, or against the community itself.

Fine Arts, the arts whose object is the production of pleasure by their immediate impression on the mind, as poetry, music, painting, and sculpture. In modern usage the term is often restricted to the imitative arts which appeal to us through the eye, namely painting, sculpture, engraving, architecture, and is sometimes even restricted to the two first as more essentially imitative and imaginative.

Fin'gal, a hero of Gaelic romance, celebrated as a great warrior and a generous man in many old ballads belonging alike to Ireland and Scotland; but more especially the hero of an epic poem attributed to Fin'gal's son Ossian, first published by James Macpherson in 1762. See *Ossian*.

Fin'gal's Cave, a famous natural cavern in the island of Staffa, one of the Western Islands of Scotland. It extends 227 feet from its mouth inward, is composed of lofty basaltic columns, beautifully jointed, and of most symmetrical, though somewhat varied forms. The height from the top of the arched roof to the mean level of the sea is 66 feet; the breadth at the entrance 42 feet, at the end of the cave 22 feet.

Finger-board, the part of a stringed instrument, as the neck of a violin, guitar, &c., to which the fingers (of the left hand) are applied in playing to stop the strings. The finger-board of a keyed instrument (played with both hands) is commonly called a *key-board*.

Fingering, in music, (*a*) the art of dexterously applying the fingers to a musical instrument in playing. (*b*) The marking of the notes of a piece of music, as for the piano, organ, harmonium, concertina, &c., so as to guide the fingers in playing.

Fingers. See *Hand*.

Fingers and Toes, a disease or malformation in the bulb of the turnip, which, instead of swelling, divides and becomes hard and useless. It is not due to the attacks of insects, but generally arises from some peculiarity of the soil, which is not well mellowed, or from injudicious cropping.

Fin'ial, in architecture, an ornamental bunch of foliage which terminates pinnacles, canopies, pediments, &c., or any ornament of like kind. By older writers the term is used to denote not only the leafy termination but the whole pyramidal mass.

Finiguerra (fin-i-gwer'rá), TOMMASO, or MASO, a Florentine goldsmith of the 15th century, one of the best workers in *niello*, a form of decorative art then much in vogue in Italy, and the inventor of the method of taking impressions from engraved plates.

Fi'ning, a substance used to clarify liquors, usually such as are out of condition or are of inferior quality. A solution of isinglass is generally used for beer, and alum, carbonate of soda, salt of tartar, &c., for spirits. Finings always destroy some of the real virtue of the liquor.

Finistère (fi-nis-tār; 'Land's End'), a de-

partment of France, so named from occupying its westernmost extremity; area, 2595 square miles. The coast-line is bold and precipitous, composed almost throughout of lofty granite cliffs, in which are numerous deep indentations, the two most important of them forming both the bay of Douarnenez and the roadstead of Brest. The interior is traversed by hills which extend in all directions. The soil is generally fertile and well cultivated; fishing is extensively carried on; and the minerals are of considerable importance, including iron, zinc, bismuth, and lead. The manufactures consist chiefly of sail-cloth, linen, soap, oil, candles, ropes, leather, paper, and tobacco. Ship-building also is carried on, and the general trade is extensive. Quimper is the capital; other towns are Brest, Châteaulin, and Morlaix. Pop. 707,820.

Finisterre, CAPE, the most western cape of Spain, on the coast of Galicia.

Fin'land, a Russian grand-duchy, containing 134,829 square miles, bounded N. by Norway, E. by the governments of Olonetz and Archangel, S. by the Gulf of Finland, W. by Sweden and the Gulf of Bothnia. The capital is Helsingfors. The country, in some parts, is hilly, being traversed by the continuations of the Scandinavian Mountains, and, in others, is sandy, marshy, and abounding in lakes, which furnish one of the most characteristic features of the scenery. Tillage and cattle-breeding are carried on to some extent; but the most valuable exports are the products of the forests, timber, pitch, tar, and rosin. The forests occupy 60 per cent of the surface. The climate is severe, but healthy; the mean yearly temperature in the north is 27.5° F., at Helsingfors 38.7°. The principal minerals are iron and copper; granite is extensively quarried. The inhabitants are mostly Finns (see FINNS) and Swedes, with a few Lapps, Russians, and Germans. Up to the 12th century the Finns lived under their own chiefs and were pagans. Their conversion to Christianity took place about the middle of that century after their conquest by the Swedes. In 1721 the part of Finland which formed the province of Wiborg was secured to Peter the Great by treaty. The remainder was conquered from the Swedes in 1809. The religion, laws, and liberties of the country have, however, been preserved, and Finland is perhaps the freest part of the Russian empire. The established religion is Lutheran; but there is complete religious free-

dom for other bodies. The national parliament consists of four estates, the nobles, the clergy, the burgesses, and the peasants, convoked by the grand-duke, the Emperor of Russia. The superior administrative power is in the hands of the senate, which is nominated by the crown, and sits at Helsingfors under the presidency of a governor-general representing the emperor. The governor-general is usually a Russian and is appointed by the emperor. All other officials, as well as the officers of the army, must be Finnish subjects. The army on the peace footing numbers about 5000, with about 20,000 reserves. Finland has its own money and system of custom-houses. Pop. 2,250,000.

Finland, GULF OF, a great arm of the Baltic, 250 or 260 miles long and from 10 to 70 miles wide, stretching from w. to e. between Finland on the n. and the Russian governments of Esthonia and St. Petersburg on the s. Its waters are only slightly salt. It contains numerous islands, several excellent harbours and strong fortresses.

Fin'lay, GEORGE, historian, born of Scotch parents at Faversham, Kent, 1799, died 1875. He was educated, chiefly at Glasgow, for the legal profession, but, stirred by the cause of Greek independence, he went to Greece in 1823, and thenceforward lived chiefly at Athens devoted to the service of his adopted country. His chief work, the *History of Greece from its Conquest by the Romans to 1864*, was published in sections under different titles: *Greece under the Romans*; *History of the Byzantine Empire*, &c.

Fin'mark, a division of Norway, in the extreme north, partly bounded by the Arctic Ocean. It consists of a mountainous and usually sterile tract, stretching 140 miles north-east to south-west, with an average breadth of about 40 miles. The Loffoden Islands belong to a long line of coast where important fisheries are established. The cod-fishery employs a large number of boats and men, and a great quantity of cod-liver oil is made. Pop. 24,075.

Finner. See *Fin-back*.

Finns, in their own language called *Suomalainen*, are a race of people inhabiting the north-west of European Russia (governments of Archangel and Olonetz), but especially the grand-duchy of Finland. In a wider sense the term Finns, with its adjective Finnic, is applied to one of the chief branches of the northern or Uralo-Altaic division of the Turanian family of

peoples and languages. The Uralo-Finnic family has been divided into four groups or branches: 1, the Ugric, to which the Ostiaks, Voguls, and Magyars belong; 2, the Bulgaric or Volgaic, consisting of the Tcheremisses and the Mordvins; 3, the Permic, composed of the Permians, Sirianes, and Votiaks; and 4, the Chudic or Baltic group. To the last belong, besides the Finns proper, the Esths of Esthonia and the Lives or Livonians, the Chudes, in the governments of Novgorod and Olonetz, and the Lapps in Archangel and the northern parts of Finland, Sweden, and Norway. The typical Finns are physically of low stature but of strong build; with round head, forehead low and arched, features flat with prominent cheek-bones, and oblique eyes. Their language belongs to the northern division of the Turanian or Uralo-Altaic family of languages, and is most nearly allied to the languages of the Esths, Lapps, Mordvins, Voguls, and Hungarians. It is agreeable to the ear, rich in vowels and diphthongs, copious, and uncommonly flexible. The language is remarkably rich in declensional forms, there being as many as fifteen different cases, expressing such relations as are expressed in English by *near, to, by, on, in, with, without, along*, &c. There is no distinction of gender in nouns. The verb resembles the noun in its capability for expressing shades of meaning by corresponding inflections. Finnish literature is valuable chiefly for its rich stores of national poetry. These poems, which had been preserved by oral tradition from the times of heathendom, were gradually dying out, till 1835, when Lönnrot grouped together in one whole all the fragments he could lay his hands on and published them, under the title of *Kalevala*, as the national epic of the Finnish people. A second edition, increased almost by one-half, was published by him in 1849. He also published a collection of 592 ancient lyric poems and 50 old ballads, and collections of proverbs and riddles. A great impulse has been given to the cultivation of the language in modern times. It is now recognized as an official language side by side with Swedish, and is becoming more and more the vehicle for imparting instruction. In many of the higher educational institutions for both sexes in Finland the Finnish language is used. Works on science and history as well as poetry have been written in Finnish in recent years; a great Finnish-Swedish dictionary has been pub-

lished, and there are now a considerable number of newspapers. The centre of this literary life is Helsingfors.

Fins, the projecting wing-like organs which enable fishes to balance themselves and assist in regulating their movements in the water. The fin consists of a thin elastic membrane supported by rays or little bony or cartilaginous ossicles. The *pectoral* or breast fins are never more than two; they are placed immediately in the rear of the gill, opening on the shoulder. In a state of rest these fins are parallel with the body, and have



Fins—Common Perch (*Perca fluviatilis*).

1 D, First Dorsal. 2 D, Second Dorsal. P, Pectoral. V, Ventral. A, Anal. C, Caudal.

the apex towards the tail. The *ventrals*, or abdominal fins, are placed under the throat or belly, and point downwards and backwards. They are smaller, in general, than the pectorals, and have sometimes long appendages. Those of the back, or the *dorsal* fins, point upwards and backwards, and vary in number from one to four, to which sometimes are added several finlets or *pinnulae*—small appendages which are seen in the mackerel. The *anal* fins are situated behind the vent, varying in number from one to three, placed vertically, and, like the dorsal, generally deeper on the anterior margin. The *caudal*, or tail fin, terminates the body, and both propels the fish and serves as the rudder by which it steers itself. The pectoral and ventral are known as *paired* fins, and represent the fore and hind limbs of other vertebrates; the dorsal, anal, and caudal are *median*, *vertical*, or *unpaired* fins, and are organs peculiar to fishes.

Finsbury, a parliamentary borough of England, forming part of London, bounded by the parliamentary boroughs of St. Pancras, Islington, Shoreditch, London City, and Westminster. Since 1885 it returns three members to parliament. Pop. 182,109.

Finster-Aarhorn (är'horn), the highest peak of the Bernese Alps, 14,026 feet above the level of the sea.

Fin'sterwalde (-vâl'de), a town in the

province of Brandenburg, Prussia, with manufactures of cotton and woollen cloths. Pop. 7564.

Fion, FIONN (fē'on), a name given in the Ossianic poetry to a semi-mythical class of warriors of superhuman size, strength, speed, and prowess. Generally they are supposed to have been a sort of Irish militia, and to have had their name from *Fion MacCumhal* (the Finn MacCoul of Dunbar, and Fingal of Macpherson), their most distinguished leader; but Mr. Skene believes them to have been of the race that inhabited Germany before the Germans, and Scotland and Ireland before the Scots.

Fiord, a geographical term (of Scandinavian origin) applied to long, narrow, and very irregularly-shaped inlets of the sea, such as diversify the coast of Norway. Similar inlets of the sea are presented in the sea-lochs of the west coast of Scotland, as also in the fiords on the south-west coast of the South Island of New Zealand, where the scenery is singularly imposing. Fiords often seem to owe their origin to the action of glaciers in remote epochs of the earth's history.

Fi orin (*Agrostis alba*), or white-top, a grass found in Northern States of America. It is not of much agricultural value. A stoloniferous variety, sometimes called *A. stolonifera*, is often a troublesome weed.

Fir, a name sometimes used as co-extensive with the term *pine*, and including the whole genus *Pinus*; sometimes restricted to trees of the genus *Abies*, which differ from the pines in their leaves growing singly, and the scales of the cones being smooth, round and thin. The term fir, thus limited, is applied to the different varieties of the *silver fir* and the *spruce fir*, the common silver fir being the *Abies picca* of botanists, while the common or Norway spruce is the *Abies excelsa*. Other species are the great Californian fir (*A. grandis*), the balm of Gilead fir (*A. balsamifera*), the large-bracted fir (*A. nobilis*), the hemlock spruce fir (*A. canadensis*), oriental fir (*A. orientalis*), white spruce fir (*A. alba*), Douglas fir (*A. Douglasii*), &c. The Scotch fir is a species of pine (*P. sylvestris*). The firs, even in the widest sense of the term, are almost all remarkable for the regularity of their growth, their tapering form, and the great altitude of their stems. Their timber is often highly valuable, being almost solely used in the construction of houses, and for the spars and masts of vessels of all kinds. Some of them

are planted mainly as ornamental trees. By some botanists the larch and cedar are included with the firs in the genus *Abies*. See *Spruce, Silver Fir, Hemlock, &c.*

Firbolgs, one of the legendary or fabulous tribes of the earliest period of Irish history. Some of the Irish historians begin their account of the Irish monarchy and list of kings with Slainge, the first Firbolg king, who began to reign 1934 B.C. They are said to have been driven out or subjugated by a kindred tribe from Scotland, who in turn were expelled or conquered by the Milesians. The Firbolgs may, it has been thought, correspond to the pre-Aryan inhabitants of Ireland.

Firdu'si, or FIRDAU'SI, ABUL KASIM MANSUR, the greatest epic poet of the Persians, was born at Khorassan about 931, and died there about 1020. At the request of the Sultan Mahmud, of Ghuznee, Firdusi undertook to write an epic on the history of the Persian kings, the sultan promising him a piece of gold for each verse. Firdusi devoted a large

number of years to this work, and produced an historical poem of 60,000 verses, entitled *Shanameh* ('Book of the Kings'), containing the history of the Persian rulers from the beginning of the world to the downfall of the Sassanian dynasty (632 A.D.), and consisting properly of a succession of historical epics. The sultan, prejudiced against Firdusi by the poet's enemies, gave him only a piece of silver for each verse. In return Firdusi retaliated with one of the bitterest and severest satires ever penned. The resentment of Mahmud compelled the poet to wander from court to court seeking a protection which the sovereigns were afraid to give. The *Shanameh* is one of the finest Asiatic poems. No work in the Persian language can be compared with it. It abounds in rich imagery, contains many passages of splendid poetry, and is of great interest to historians and ethnologists. A French translation of the *Shanameh* by Mohl, with the Persian text, was published by the French government.

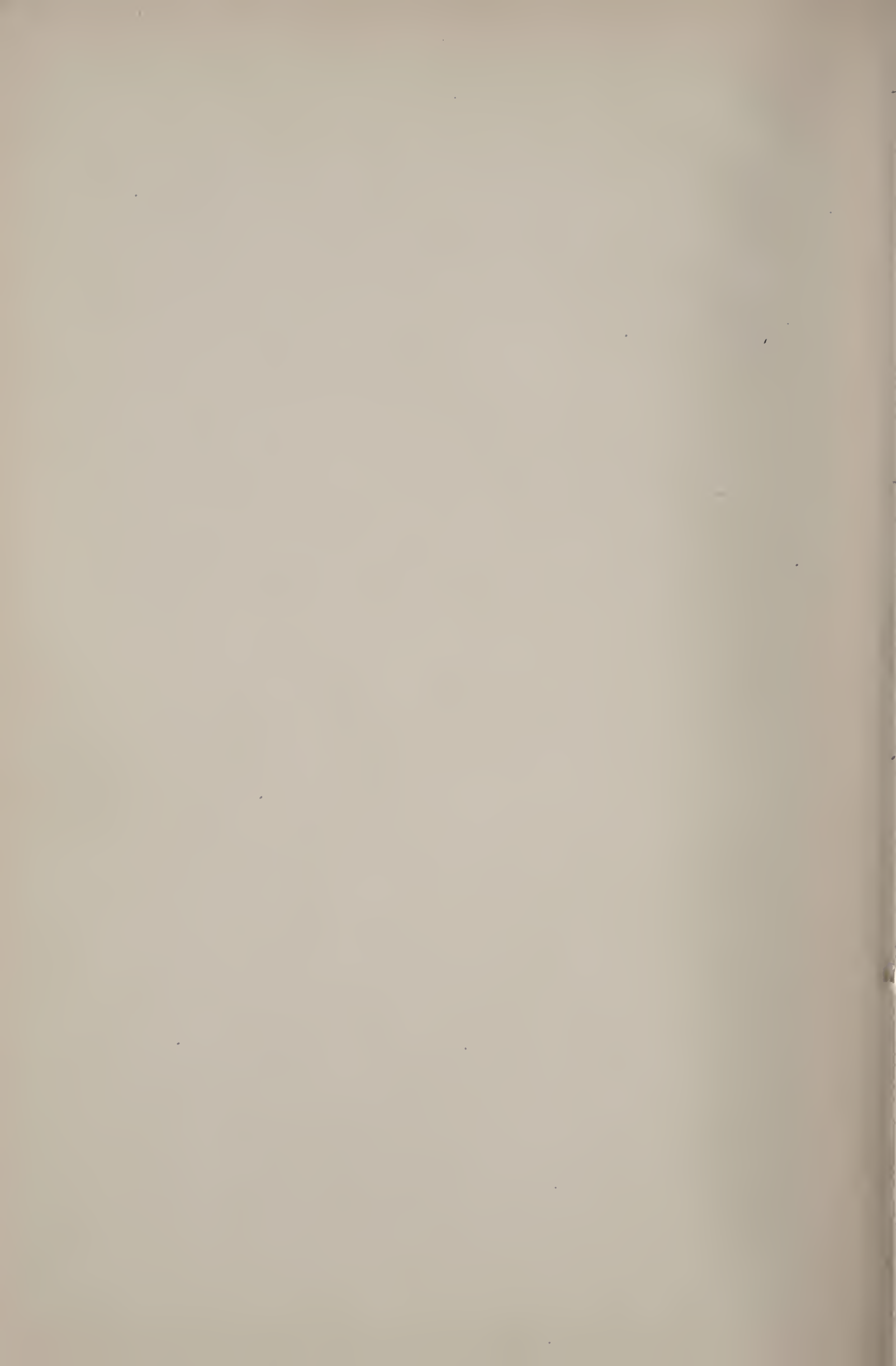





LIBRARY OF CONGRESS



0 038 701 438 A