

AMERICAN  
GARMENT CUTTER

---

MEN'S GARMENTS

THIRD EDITION



Class 7.1500

Book 102

Copyright N<sup>o</sup> 1234

**COPYRIGHT DEPOSIT.**





THE  
AMERICAN GARMENT CUTTER

THIRD EDITION

¶ A complete, practical up-to-date  
treatise on the Cutting of

MEN'S GARMENTS

according to the most approved  
method ❀ ❀ ❀ ❀ ❀



AMERICAN FASHION COMPANY

PUBLISHERS

NEW YORK LONDON PARIS BERLIN VIENNA

TT 590  
R+  
C14-

INTERNATIONAL COPYRIGHT, 1914

---

ENTERED ACCORDING TO ACT OF CONGRESS IN THE YEAR 1914

BY

AMERICAN FASHION COMPANY

IN THE OFFICE OF THE LIBRARIAN AT WASHINGTON, D. C.

---

ALL RIGHTS RESERVED

REPRODUCTION INTERDITE

VERVIELFAELTIGUNG UNTERS AGT

14-19342

OCT 14 1914

©CLASS0855

E. H. ... 21/14

## INTRODUCTION

Draper in his "Intellectual Advancement of Civilization" says: "Individual advancement is the model for social progress. Nowhere is the truth of this to be found so fully realized as in these United States, where individual advancement is marked in every avenue of life. "Excelsior" is inscribed on the banner of every man and woman, borne onward and forward through the rush and crush, through the whirlpools and fast flowing streams of life's kaleidoscopic changes, ever reaching higher and higher and becoming more and more and still more perfect in their particular sphere and in their own individual calling.

For twenty years the author has devoted his time and study to the compilation of a book for self-instruction in the art of cutting and designing men's garments, so arranged that any one of average intelligence can master it with proper care and necessary diligence.

The student will find the system extremely simple and entirely free from complication; no scale or chart of any kind is used, simply the ordinary divided square and inch tape measure; everything which might have a tendency to befog and mislead the student has been eliminated, so that every line drawn and applied may be easily grasped and perfectly understood. To produce a method of cutting where the points are based on the actual build of a man, and to be reproduced as nearly perfect as is possible to human ingenuity is what has been sought in this work. The author has so far succeeded that of the many who have studied, either by direct instruction or by the aid of this publication, not one has failed to enjoy the fullest confidence of their clientage. Particularly is this system of value where cutting has to be done without "try-on," and at no time can a garment be spoiled. The perfect points being the fundamental object of this method.

## PREFACE

In placing this work before the Cutting Fraternity, we feel confident that we have placed before them something that is useful and practical. Unlike any other work of its kind, its construction is simple and easy to understand. It has been our aim to eliminate all discussion of an anatomical nature, for we do not pretend to teach anatomy, nor do we try to convince the student of something we are not convinced of ourselves. We do claim that our work is absolutely practical, and correct, its measures are simple, and applied on the pattern exactly as taken, they will cover any and all points that have heretofore confused the cutter. There will be no need for the cutter to mark on the book "R. B." for round back or "O. E." for over erect or any other sign by which to show the shape of his customer, for his measurements will show all such points. We feel certain that any cutter following the instruction of the AMERICAN GARMENT CUTTER will be satisfied with the results obtained.

THE AUTHOR

S. REGAL.



## PREFACE TO THIRD EDITION

The publication of the first and second editions of this work marked an era in the history of cutting, as it was the introduction of a Self-Instructor that enabled the student to intelligently understand a system that was Simple, Concise and Practical.

The many systems that were heretofore published, advanced theories and expounded systems that proved to be so intricate and ambiguous they left the student floundering in uncertainty, and necessitated either a course of personal instruction, or a return to his former system that had proved unsatisfactory.

The great success that attended the sale of the first and second editions of this work is evidenced by that fact that many orders have been held in abeyance pending the publication of this edition, the first and second issues having been entirely sold out many months ago.

That the Author has succeeded in producing a work fulfilling all the requirements of a Self-Instructor is attested to by the result that not a single request for an explanation of any point has been received since the first and second issues were presented to the public.

Whilst the fundamental principles of the system taught in the previous editions have been retained, yet some changes have been made that practical experience has found to be beneficial, and many diagrams of garments added that make this the most complete work on Garment Cutting ever published.

Whether it be a Practical Cutter or Tailor, or one totally unacquainted with the art of Cutting, the Author is convinced that any person of average intelligence can become a master of the art through the medium of this publication.

The system as taught does not require changing when the vagaries of Fashion decree a different style, but can be used for all time, and embrace within its scope every outer garment worn by man.

The claims made for this work are fully borne out by the success attained by those who studied the first and second editions, and we know that it will meet with the same favor as its predecessor, and be of invaluable use to those who purchase it.

THE AUTHOR,  
S. REGAL.

### THE MEASURING OF THE HUMAN BODY.

The fact that in order to perfectly fit the human body perfect measurements are required, cannot be too often urged upon the cutter, and not only that, but it requires much tact on the part of the cutter to get his customer to forget that he is being measured. A fact well known among cutters is, that ninety-nine out of one hundred men will pose, unconsciously perhaps, while being measured. It is common to see a man standing erect, with shoulders thrown back and chest expanded, and if you were to ask him to stand natural, he would be indignant and answer, "why of course this is my natural position," but if after the garment is completed, he stoops forward, his chest sunken in, his back rounded, it will then be necessary for the cutter to either make a big alteration or a new garment; so it will readily be seen that the cutter who can make his customer forget that he is being measured, has the best chance of success.

If my opinion was asked as to whether actual measurements or proportions were the safest method to cut by, my answer would be actual measurements by all means, providing you have the ability to take an accurate measurement, otherwise use proportions. Proportions, therefore, would be my second choice, and judging by the various measuring devices that are being studied and invented, it would seem as if a great number of cutters are realizing that the proper measurements of the body is one of the greatest, if not the greatest, factor in producing that which the cutter is aiming to produce. But so far as I can see, no instrument has yet been devised that can really give a good measurement, *i. e.*, an instrument which the young student, as well as the practical cutter, can handle with an equal degree of confidence and certainty.

From my experience, I find that the only correct line needed for attitude is the horizontal line, this being the breast line. If such a line could be definitely located, the difficulty in measurements would be done away with. I therefore advise using the floor level for the breast line, as is shown in this book, and even if the breast line is taken one-quarter or one-half inch lower than the actual depth the armseye calls for, or if taken that much higher than it should be, then it will still leave the front and back lengths from the floor level the same. Consequently, if the scye depth is one-half inch too deep, so is the front shoulder length, and if too high, so is the front shoulder length. The balance, therefore must be the same.

The next important measurement is the waist indentation. We all know that the greater the waist hollow, the more back length we need, and that length can only be had by hollowing the backpart at the waist the proper amount to correspond with the indentation; this will adjust the lengths of the backpart from the breast line down, the same as the scye depth and strap will adjust it from the scye depth up.

### HOW TO MEASURE.

Before measuring, it is well to see that the sides of the Vest are not too loose; if necessary, pin up both sides of the Vest, but see that the center seam of the back is in the right place.

Use the ordinary division square. Place square under the arm with the long end down and parallel with the body. (See Fig. 1). The short end to be close, but not tight, under the arm; make a chalk mark on top of it in front.

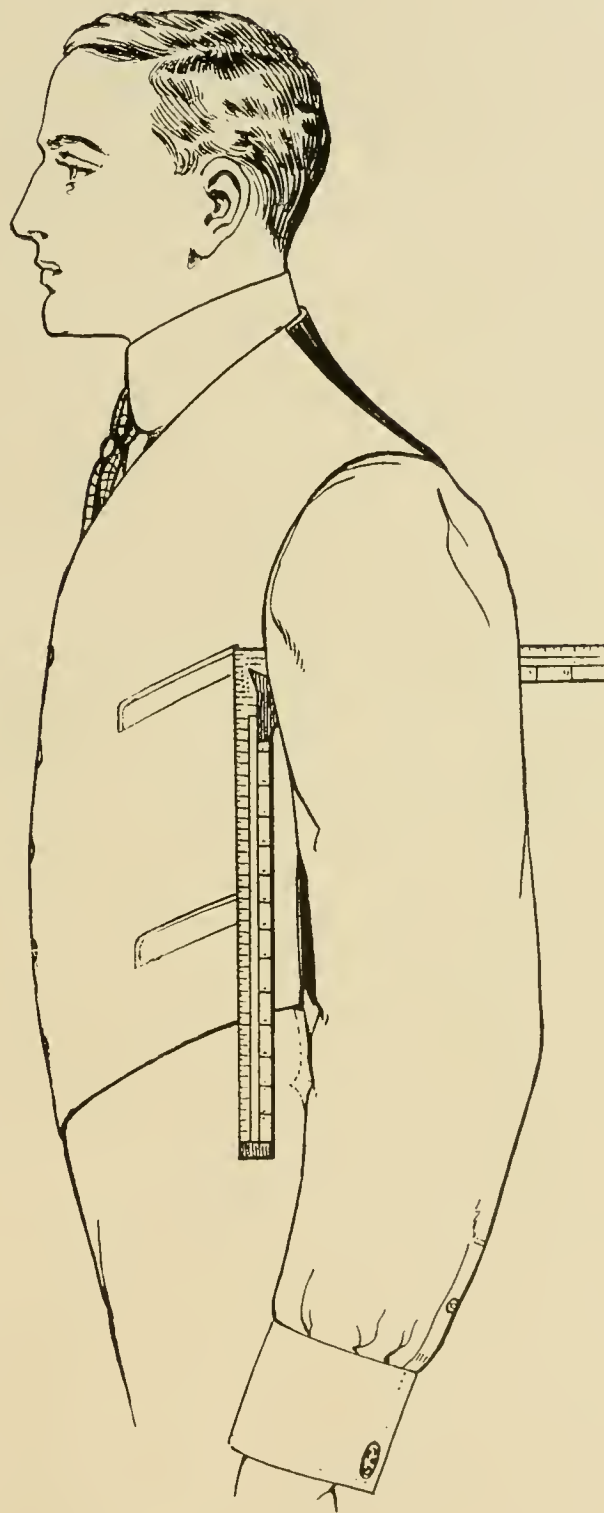

FIGURE 1.

## HOW TO MEASURE (Continued)

Now place the short end of the square under the arm with the long end upward (see Fig. 2), still keeping the inner edge of it close, but not tight, at the front scye; mark at the outer edge of it across the first line, so that it leaves a cross mark at the front scye.

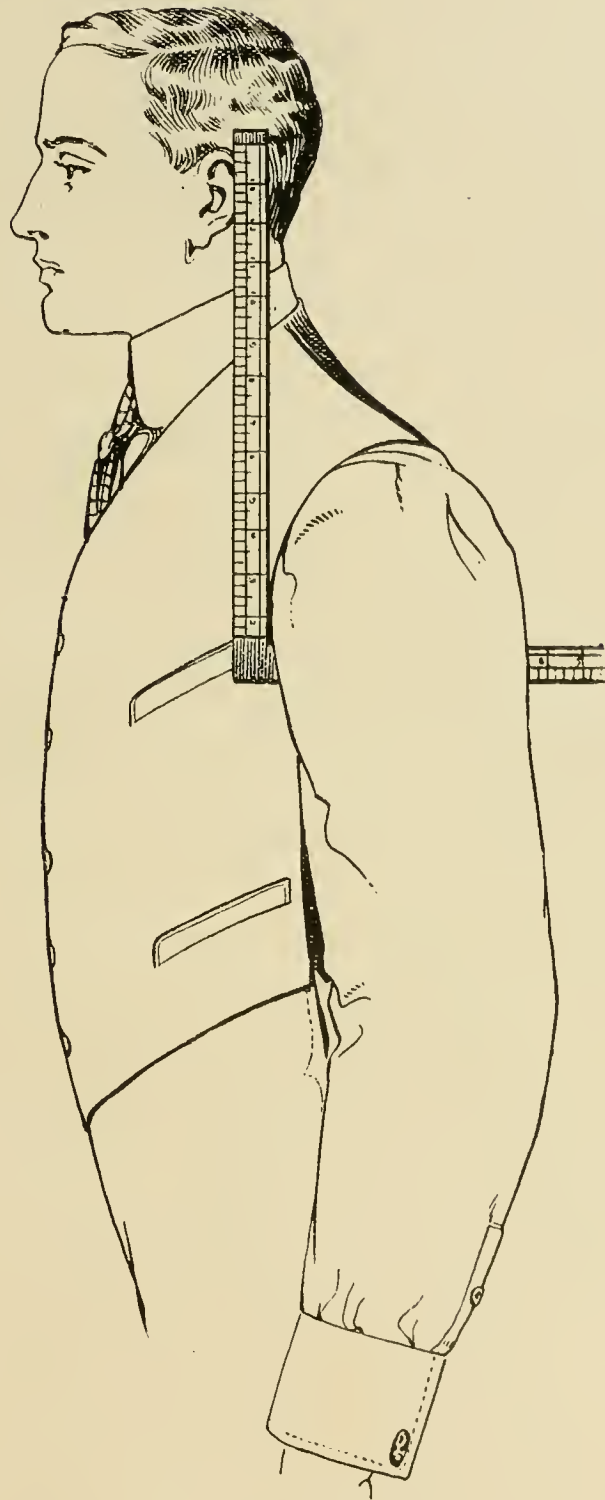

FIGURE 2.

## HOW TO MEASURE (Continued)

The cross mark shown on the front on Figure 3 shows where the line of scye depth and blade line cross.

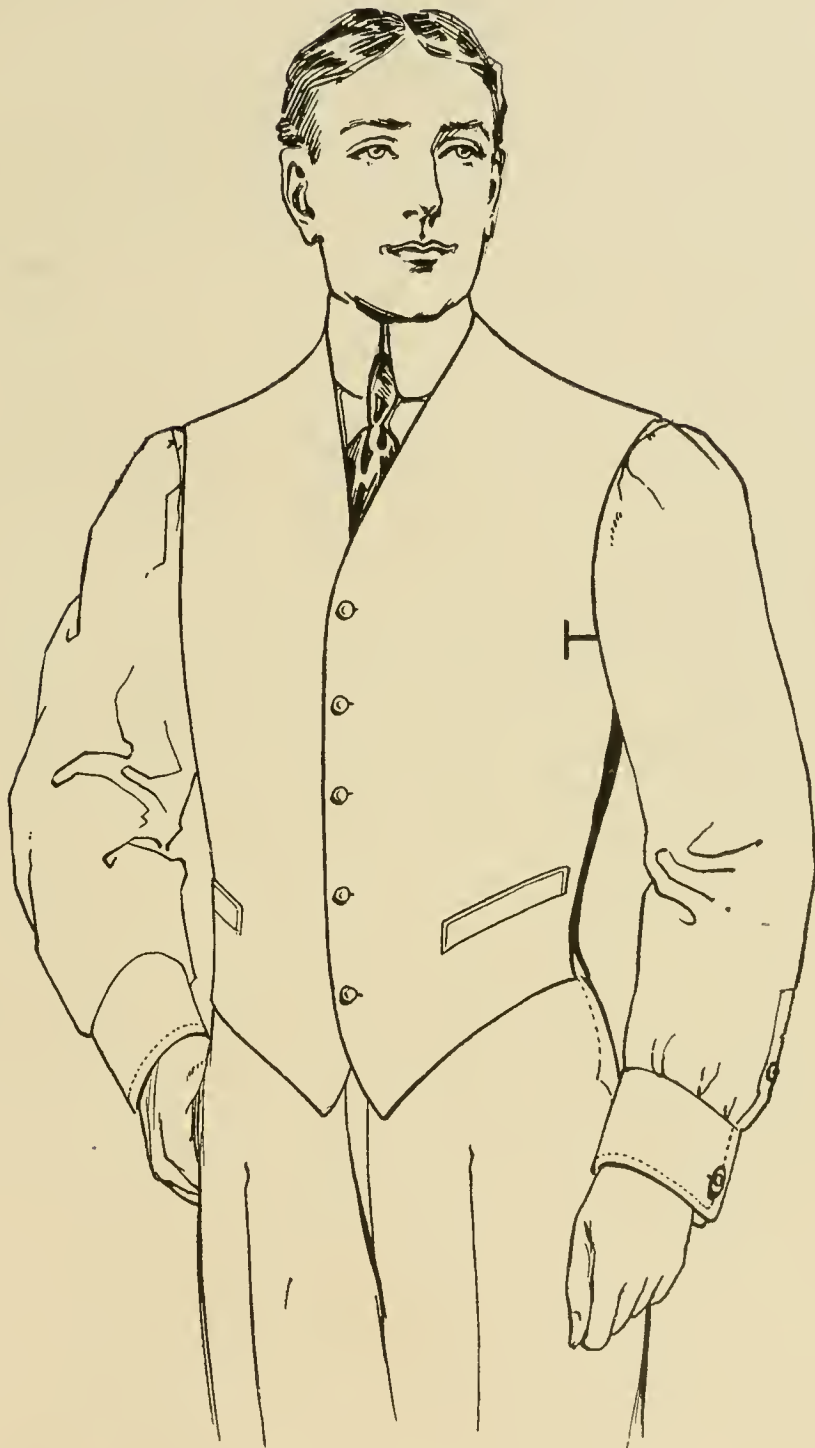

FIGURE 3.

## HOW TO MEASURE (Continued)

After obtaining this point, place the square and yardstick together (Fig. 4) and measure the distance from that square line down to the floor as shown.

After the length is obtained, proceed as per Fig. 5. Mark the same distance from the ground up on the backpart on each side.



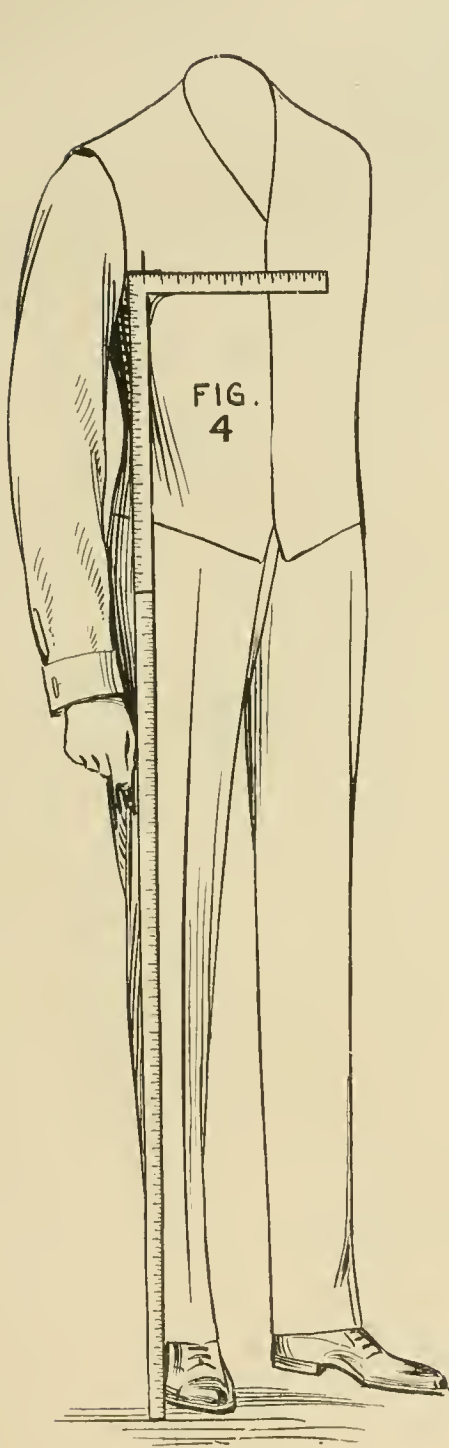

FIGURE 4.

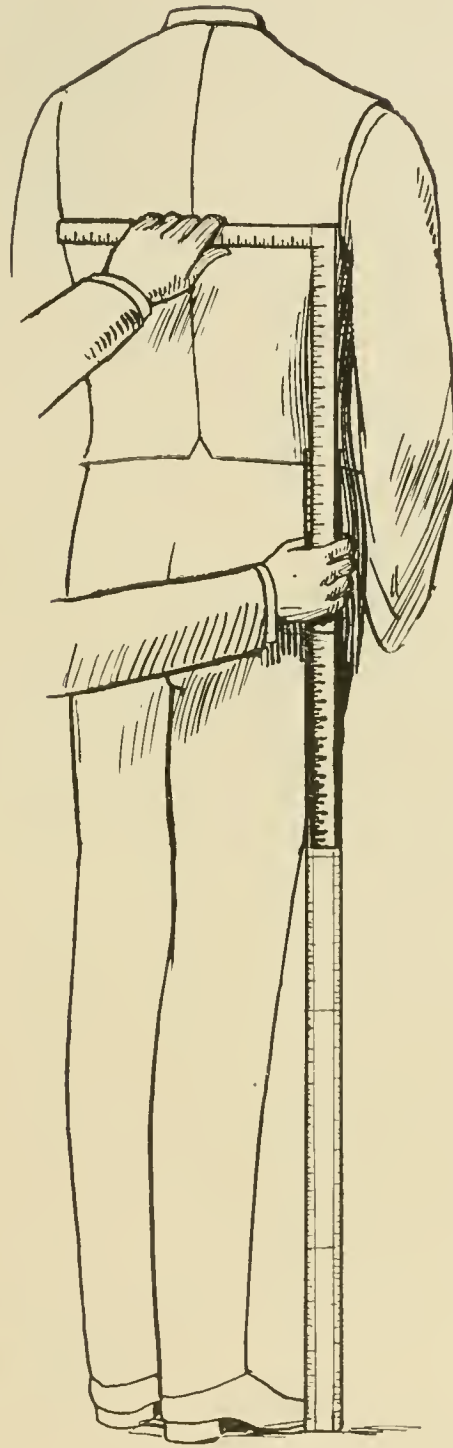

FIGURE 5.

#### HOW TO MEASURE (Continued)

Place the square across the two lines and mark on the center seam. (Fig. 6). Now place the tape string around the hollow part of the waist and mark the waist length at C. Go down from C to D six inches for the hip measure. It is easily understood that no matter where the hip may be, so long as you go down the same distance for the draft as the measure, you must be right.

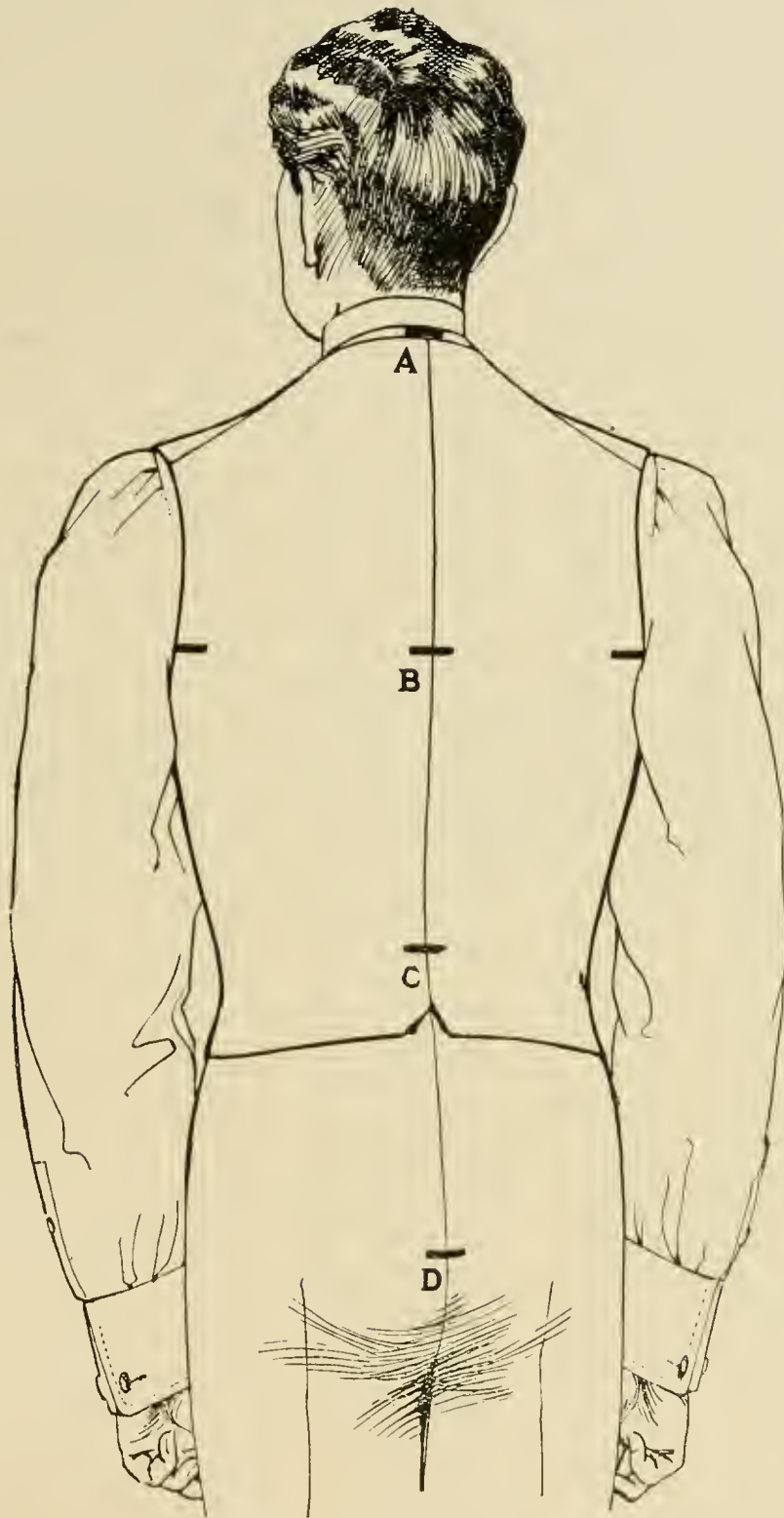

FIGURE 6.

## HOW TO MEASURE (Continued)

(Fig. 7). Now place the yardstick against the back and seat, and place the square to the hollow of the waist to see how much indentation there is between the waist hollow and the stick. Now, the average indentation at that place is  $1\frac{1}{2}$  inches, but this may be more or less. We shall explain later on how this measurement is used.

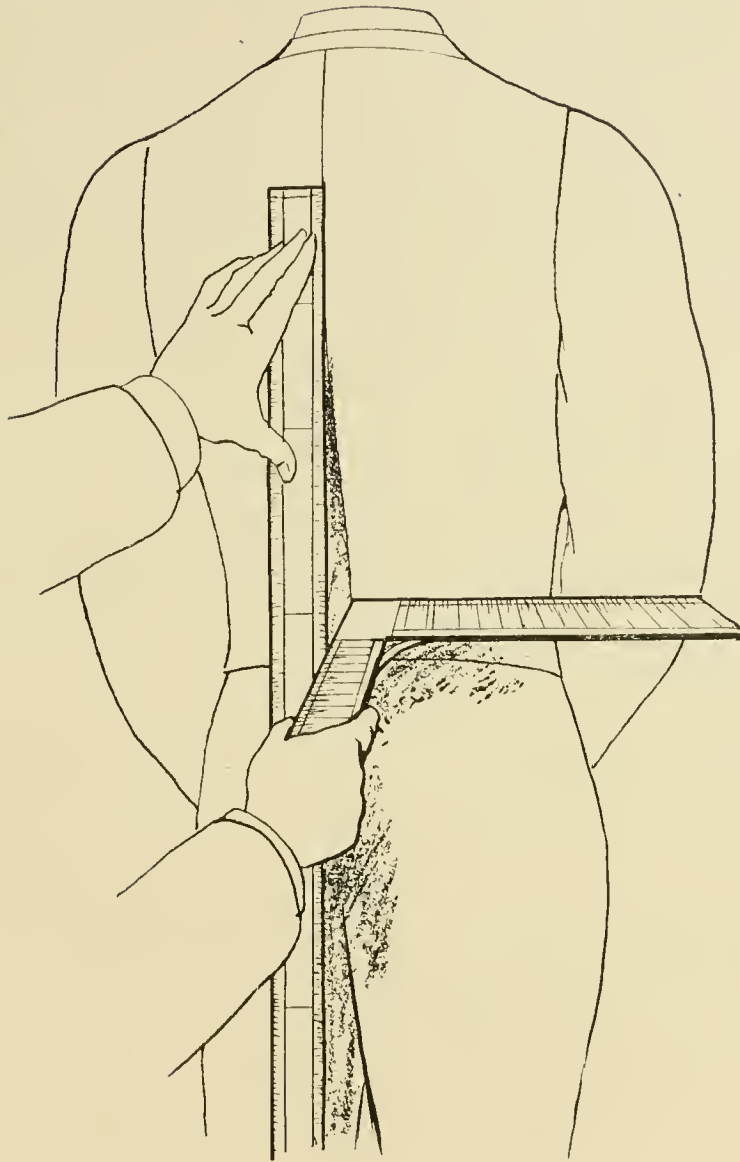

FIGURE 7.

## HOW TO MEASURE (Continued)

(Fig. 8). Now beginning at the collar button, proceed to measure as follows: first from the socket bone or collar button to the scye depth; on to the waist length and full length. It is not necessary to call off the seat length for the simple reason that the seat length is always 6 inches below the waist.

-----  
 (Fig. 9). Now take the strap measure from the collar button down to the front mark.

-----  
 (Fig. 10). The oversoulder measure from the scye depth at the center of back, across the shoulder to the front cross mark.

-----  
 (Fig. 11). The blade measure, from the front cross line under the arm and over the blade to the center seam of the backpart as illustrated. The breast measure, which should be taken naturally, neither too loose nor too tight, should be taken over the largest part of the blade. Then take the waist and seat measure. In taking the seat measure, we always make our additions to the measurements in the following manner: let us assume that the man to be measured has two hip pockets in his trousers. If at the time of taking the measure, there should be nothing in either pocket, we add 1 inch to the measurements; should the one pocket be full and the other one empty, we give  $\frac{1}{2}$  inch; should both pockets be reasonably full, we take the measurements easy and call it net.

## THE VEST.

If measured for a suit, all that is needed is the opening and full length measure, otherwise take the same measurements as for the coat.

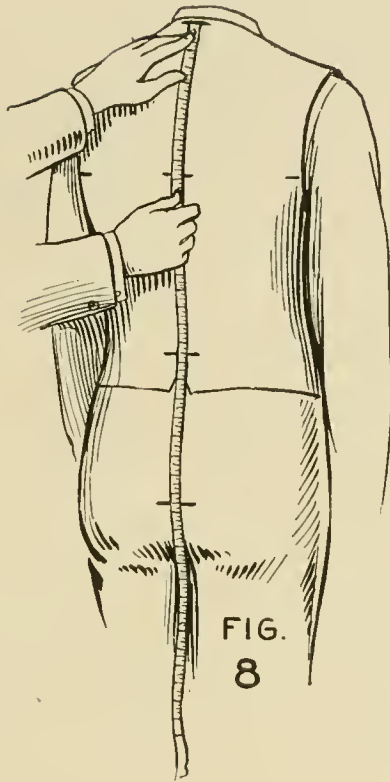

FIG.  
8

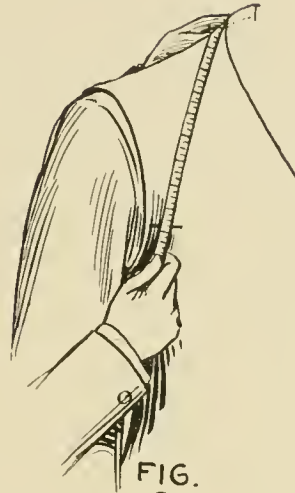

FIG.  
9

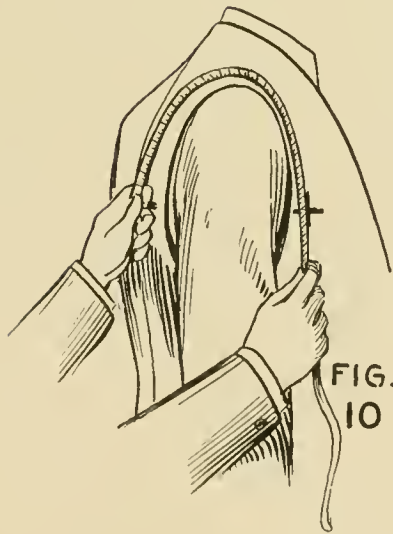

FIG.  
10

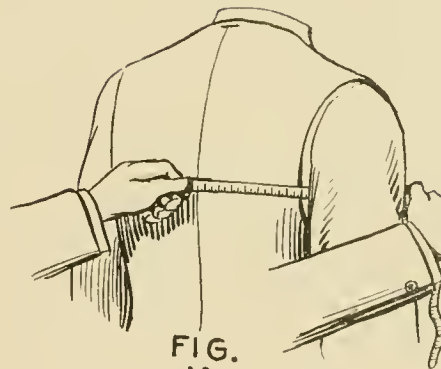

FIG.  
11

## HOW TO MEASURE (Continued)

## TROUSERS.

Measure the outside seam from the hip bone to the top of heel and reduce  $\frac{3}{4}$  inch.

For the inseam, have the trousers well drawn up and measure from the crotch to the top of heel and reduce  $\frac{3}{4}$  inch; then measure the waist, hip, seat, thigh, knee and bottom.

In measuring the trouser length, it must be remembered that if the trousers were made to come down to the top of heel they would be entirely too long for wear, but if made  $\frac{3}{4}$  inch above the heel it will give them the right length for medium widths. If the trouser legs are to be very narrow, the reduction may be 1 inch; very wide trousers may be reduced  $\frac{1}{2}$  inch but trousers with a permanent turn-up should be made from  $1\frac{1}{4}$  to 2 inches shorter than the actual measurements.



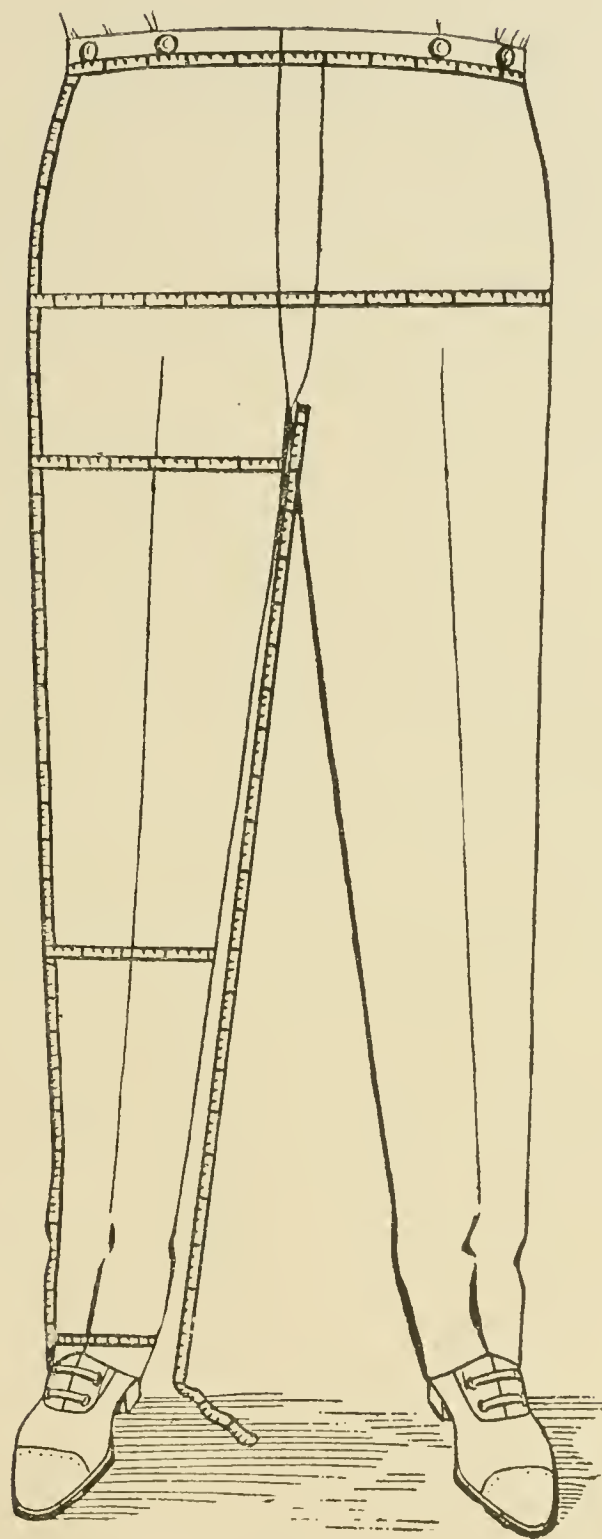

FIGURE 12.

## AMERICAN GARMENT CUTTER

## THE SQUARE.

The square used for these diagrams is a plain division square, understood by most cutters, but for the benefit of those who do not understand it, we herewith give an explanation of the divisions of same.

The long end of the square is divided into  $\frac{1}{8}$ ,  $\frac{3}{8}$ ,  $\frac{1}{2}$ ,  $\frac{5}{8}$ , 1-24; the short end is divided into  $\frac{1}{2}$ ,  $\frac{1}{4}$ ,  $\frac{1}{8}$ , 1-16 and 1-32. Should you try to find  $\frac{1}{8}$  of any size, say 36, 40 or 48, look at the short end of the square marked  $\frac{1}{8}$ , and there you will find the number you want, 18 for 36, 20 for 40, or 24 for 48. Should you want  $\frac{1}{2}$  of any size, look at the same short end of square marked  $\frac{1}{2}$ , or if you want  $\frac{1}{4}$ ,  $\frac{3}{8}$  or  $\frac{5}{8}$ , look at the long end for the mark  $\frac{1}{4}$ ,  $\frac{3}{8}$  or  $\frac{5}{8}$  and you will find it.

In drawing for square lines, be sure that you hold your square on the one line firmly, while drawing the right angle, for one line off will spoil the whole draft.

## DIAGRAM 1.

We will now proceed with the first lesson which is the groundwork. The measurements for this diagram are as follows:

Indentation .....	1½ inches
Scye depth .....	9 inches
Waist length .....	16½ inches
Full length .....	30 inches or whatever it might be
Strap .....	12 inches
Overshoulder .....	17 inches
Blade .....	12½ inches
Breast .....	36 inches
Waist .....	32 inches
Hip .....	38 inches

Square down and out from A.

From A to B is the scye depth plus  $\frac{1}{4}$  inch; to C is natural waist length; C to D is 6 inches always; A to E is full length; F is halfway between A and B; G is halfway between A and F; square out from G, B, C, D and E.

From C to 2 is one-half the indentation, in this case  $\frac{3}{4}$  inch; from E to 22 is one-half the distance of C to 2, in this case  $\frac{3}{8}$  inch. This is for body fitting coats. If the coat is to be loose, make the distance from E to 22 the same as C to 2, but if the coat is to be a full box coat, then draw a line from F through 2 down to the bottom. Draw a line from F to 2 and from 2 to 22 and shape the center seam; this locates point 1.

From 1 to H is one-half full breast; H to I is  $1\frac{3}{4}$  inches; I to J is  $\frac{3}{4}$  inch; K is halfway between I and H; from K to L is  $3\frac{1}{2}$  inches always; square down from L; this line drawn down from L is used as the waist division and never changes; now apply the blade measure from I to L which is  $12\frac{1}{2}$  inches and make no additions to it, because in taking the measure we have made a mark in front of the square which gives us the necessary addition; square up from L.

Now let it be understood that the blade measure does not always come even with the line squared down from L, as the increase or decrease of the blade measure may move the line either forwards or backwards from that point. This will be more fully explained as we proceed with our diagrams.

Point M is  $\frac{1}{2}$  of the blade measure, which is halfway between I and L; from M to N is  $1\frac{1}{4}$  inches; square up from N; this locates O; point 4 is halfway between M and N, but this may be moved forwards to N or further backwards in accordance with the style coat desired. If the back is to be very shapely, we can move point 4 back as far as point M or if the back is to be straight, we may move it forwards to N.

From 22 to 7 is the same distance as from 1 to 4; draw a line from 4 to 7; from N up to P is  $\frac{1}{2}$  breast; square forwards from P; from P to X is  $\frac{1}{2}$  inch; from A to 8 is  $6\frac{3}{8}$  inches; from 8 to 9 is  $1\frac{1}{2}$  inches; draw a line from A to 9; from A to 10 is  $\frac{1}{2}$  breast; square up from 10 to locate 11; draw a line from about  $\frac{1}{4}$  inch below 11 to O; from Q to R is  $\frac{1}{2}$  indentation, in this case  $\frac{3}{4}$  inch; from Q to S is  $\frac{1}{2}$  waist; place the square to points R-S and square down; this will regulate the front edge.

I consider the waist indentation as normal at  $1\frac{1}{2}$  inches; if the waist indentation is greater than  $1\frac{1}{2}$  inches, the body is sway back. In such a case, the front edge retreats from the waist down and causes the side seam to swing further back. Point T is halfway between Q and S; point U is halfway between L and I; draw a line from T through U up.

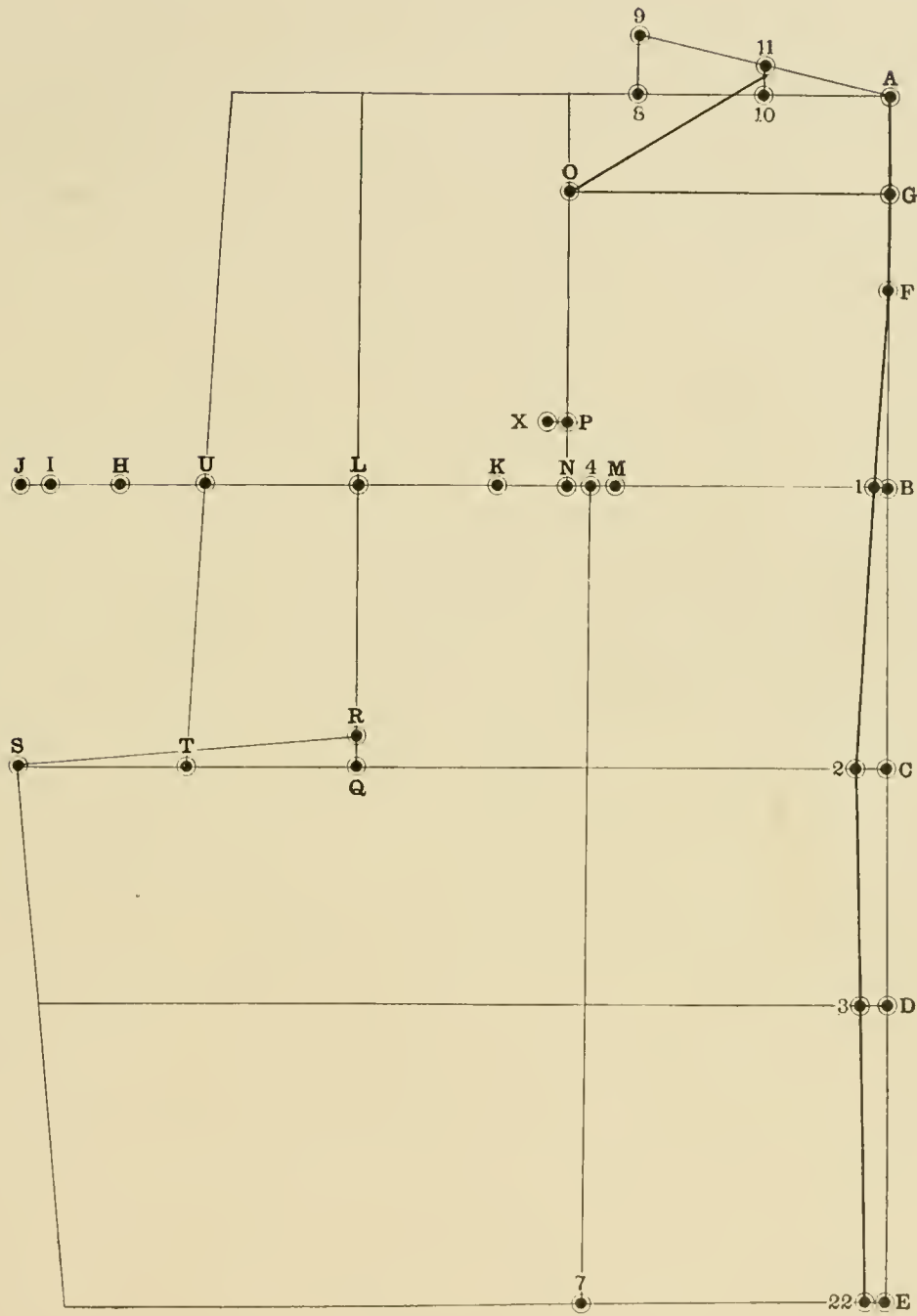

DIAGRAM 1.

## DIAGRAM 2

Measure the distance from A to 11 which is the top width of back; apply this amount to point L and measure up to V the strap measure plus  $\frac{3}{4}$  inch for seams; draw a line from V to O; from V to Z is  $\frac{3}{8}$  inch less than the width of the back shoulder. This is not for stretching, but the backpart is to be fulled in against the forepart  $\frac{3}{8}$  inch; shape the shoulder from about  $\frac{3}{8}$  inch below the line up to V and also the armseye as shown.

Square forwards from V by line T-U; from V to W is  $\frac{1}{2}$  breast plus  $\frac{1}{2}$  inch; draw a rounding line from W to J; this line is necessary for a coat that is to button up to the neck; in this case, however, it is only a guide for the gorge.

From V to Y is  $\frac{1}{8}$  breast; W to X is  $\frac{1}{8}$  breast; this distance may be increased or decreased in accordance with the prevailing style; draw a line from Y to X and shape the gorge; from J to 12 is 1 inch; S to 13 is the same; square down from 13 by line R-S; this locates 6; from 6 to 15 is 3 inches.

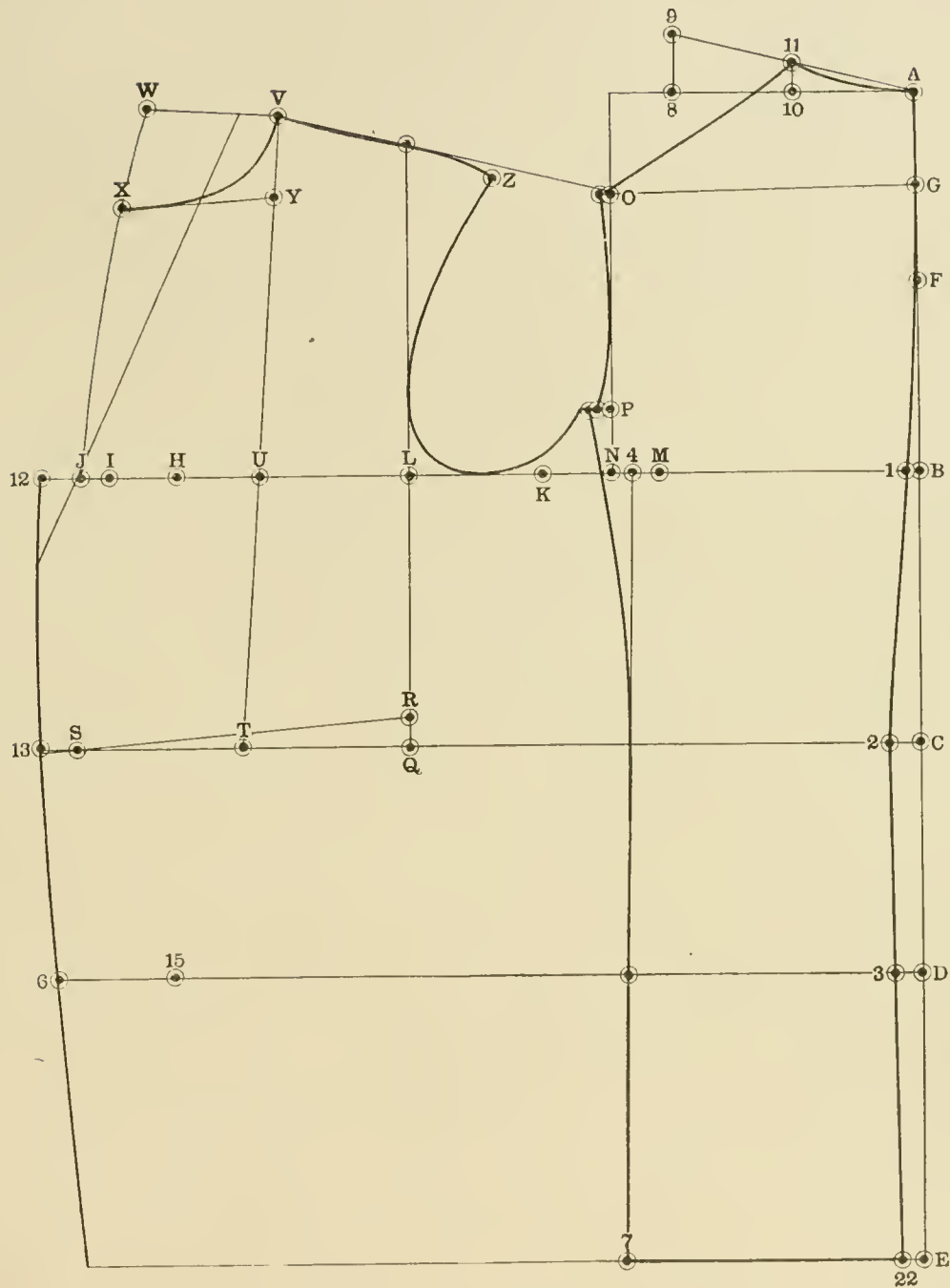

DIAGRAM 2.

## DIAGRAM 3

Apply the seat measure from 23 to 3 and from 15 to 20; the additions to this seat have already been made in the measurements, therefore the measurements are applied net. From 20 back to 19 is 2 inches; square up from 19 to locate 18; draw a line from 18 through 20 down and shape the side of the forepart as shown; from 18 to 21 is the same distance as from 5 to 7; from 16 to 17 is  $\frac{1}{8}$  breast; shape the bottom of forepart from 21 to 17.

Now if a close-fitting coat is desired, proceed as follows: from S back to 11 is  $2\frac{1}{2}$  inches; apply the waist measure from 5 to 2 and from 14 to 18; the surplus that you will find between the actual measure and 18 is to be taken out as an under-arm fish as shown. Where an under-arm fish is cut out from the forepart, lower the scye as at K one-half the amount that has been cut out at the waist. This is not for chest effect. It is merely that the side of the forepart should be held short at the waist and even on the top.

## THE COLLAR

If a straight crease collar is desired, proceed as follows: from V to 34 is  $1\frac{1}{4}$  inches; this represents the collar stand; draw a line through 34 to where the top button hole is placed; from 24 to 25 is  $1\frac{1}{4}$  inches; shape the collar stand from 25 through V into the gorge; from V to 25 is  $\frac{3}{8}$  inch more than the top width of back; square up from 25 to 24; from 24 to 26 is the width of the collar desired plus a seam; finish the collar as shown. On another page we will show different kinds of collars.

To mark the pocket, proceed as follows: place the square to line R-S and square down; from L to 27 is  $\frac{2}{3}$  of the sleeve length plus  $\frac{1}{2}$  inch but this may be changed in cases where the style of sack coat is extremely short or extremely long. Under these conditions, the distance may be increased or decreased to correspond with the coat style. Measure the distance from the bottom of the forepart up to 28 and also 29; the pocket should run parallel with the bottom of the forepart.

Make the distance from 27 to 28 about  $\frac{1}{6}$  breast and from 28 back to 29 the size pocket desired; if a ticket pocket is wanted, place the square to lines 28-29 and square up to 30; from 28 to 30 is  $3\frac{1}{2}$  inches; square forwards and backwards from 30; from 30 to 31 is 1 inch; 31 to 32 is  $3\frac{1}{2}$  inches.

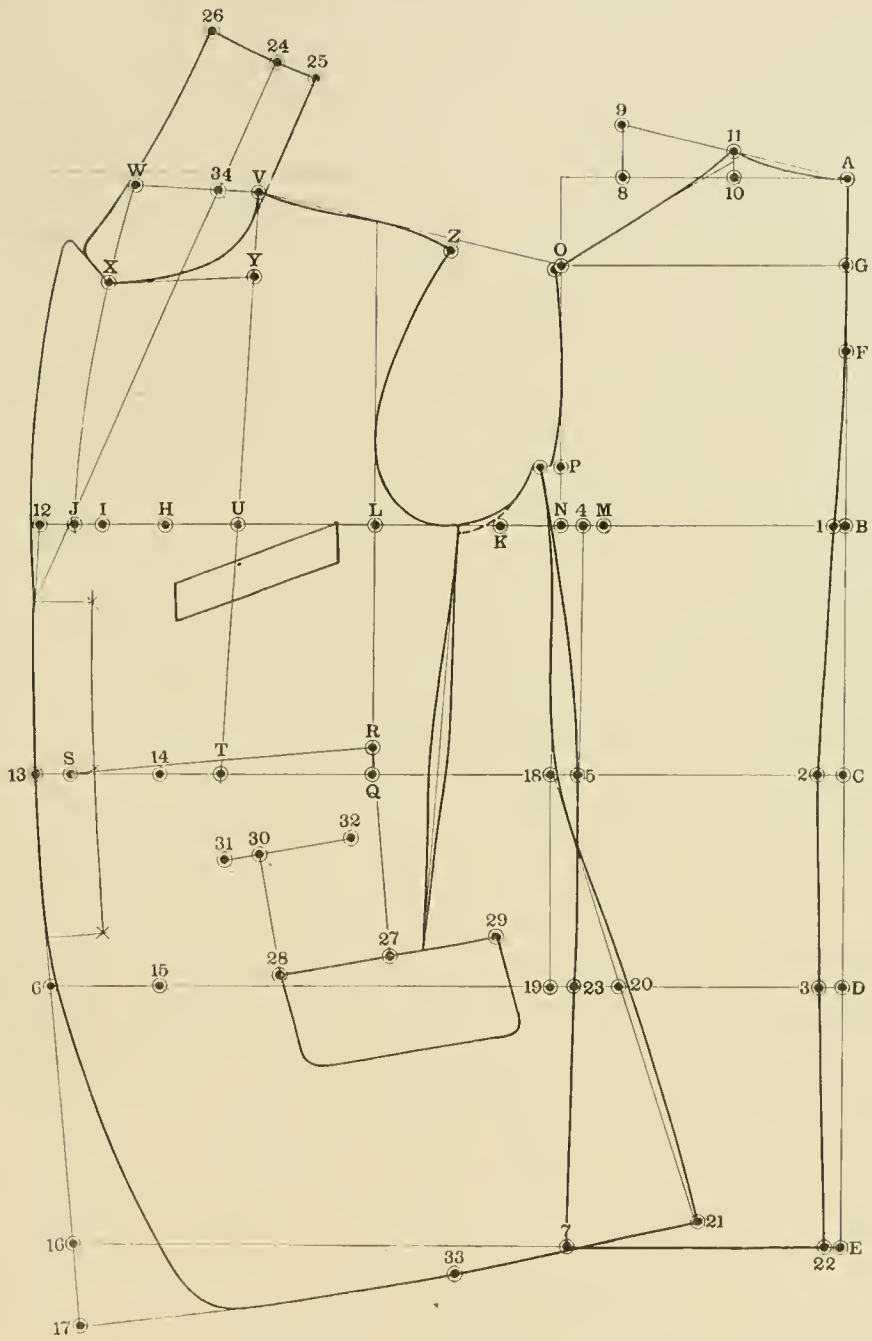

DIAGRAM 3.

---

 DIAGRAM 4

After the backpart and before the forepart is cut out place the back shoulder seam to the front shoulder as shown on this diagram and apply the oversoulder measure plus 1 inch, from B to L; if correct, reshape the gorge and also the armseye so as to carry the lines perfectly and cut out the forepart.

---

 DIAGRAM 5

Should the oversoulder be too long, overlap it as from Z to Y until the proper measurement plus 1 inch addition is obtained and reshape the shoulder as shown on this diagram.

---

 DIAGRAM 6

In case an artificially high shoulder is desired, proceed as in diagram 6; draw a line from the breast line up to A, also draw a line across the shoulder as at F-G; open the shoulder from F to G say  $\frac{3}{8}$  or  $\frac{1}{2}$  inch, allowing it to overlap at the gorge. This will advance the shoulder point as from A to D and raise it as at E; reshape the shoulder, gorge and armseye as shown by the broken line.



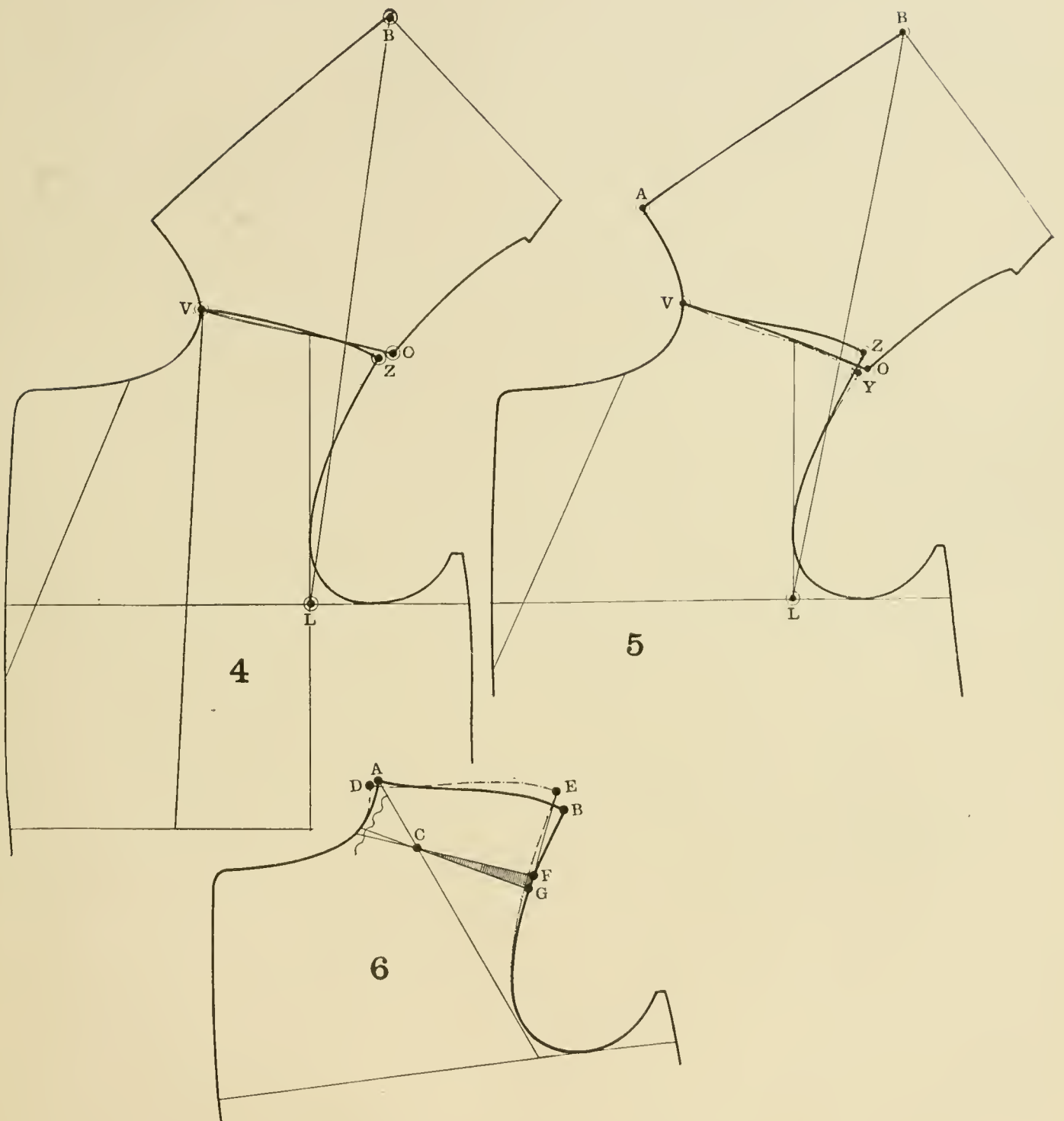

DIAGRAMS 4, 5, 6.

### DIAGRAM 7

Should one shoulder be higher than the other, always take your measurements on the high side and cut your pattern for that side, but make your changes on the low side as shown on diagram 7.

Let us assume that the low shoulder is  $\frac{1}{2}$  inch low, then proceed as follows: lower the back from 13 to 14 say  $\frac{1}{2}$  inch and from 11 to 12 the same; place your regular backpart to point 14 and mark it as per broken line from 12 to 11; now pivot your backpart at 12 and swing it until point 10 will strike on line 9; reshape the backpart as per broken line; shorten the forepart from 15 to 16 the same amount as the backpart has been lowered from 13 to 14.

---

### DIAGRAM 8

It often happens that the body swings over to one side, in which case it appears that one shoulder is lower than the other and yet if both shoulders were measured separately, the measurements on both sides would be the same. Still on the low side, the coat would strike against the seat and the same amount would swing off on the high side in which case the change should be made as shown on this diagram.

After the forepart and backpart have been cut for the high side, split the backpart as from 1 to 2; overlap it from 2 to 3 the amount the one shoulder is lower than the other and do the same with the front part; split the front part as from 4 to 5 and overlap it from 5 to 6 the same amount as the backpart has been overlapped from 2 to 3; straighten the center seam of the back as shown by the broken line and fill in the side seam the same amount.

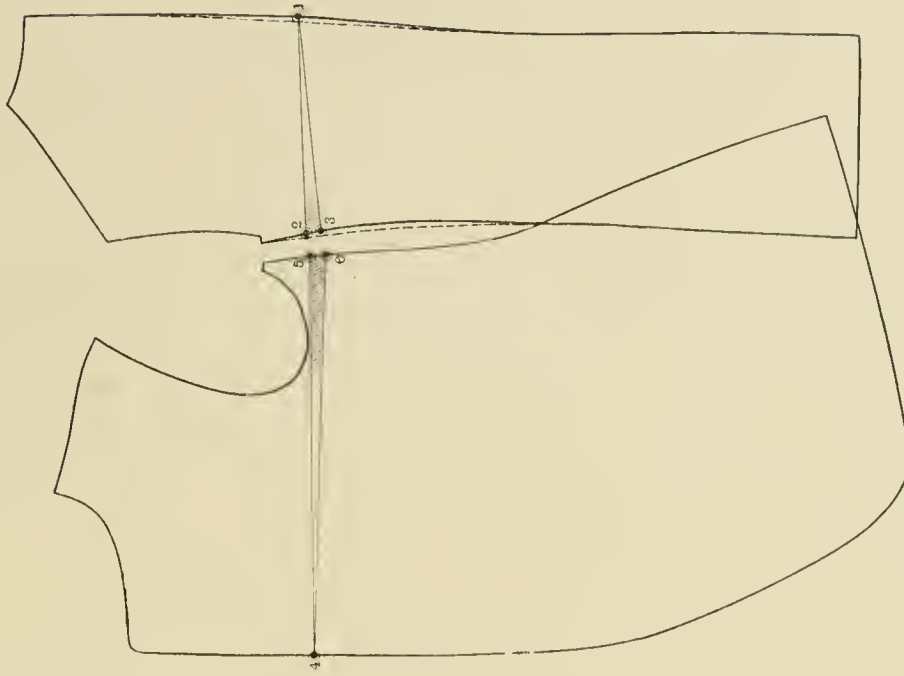

DIAGRAM 8.

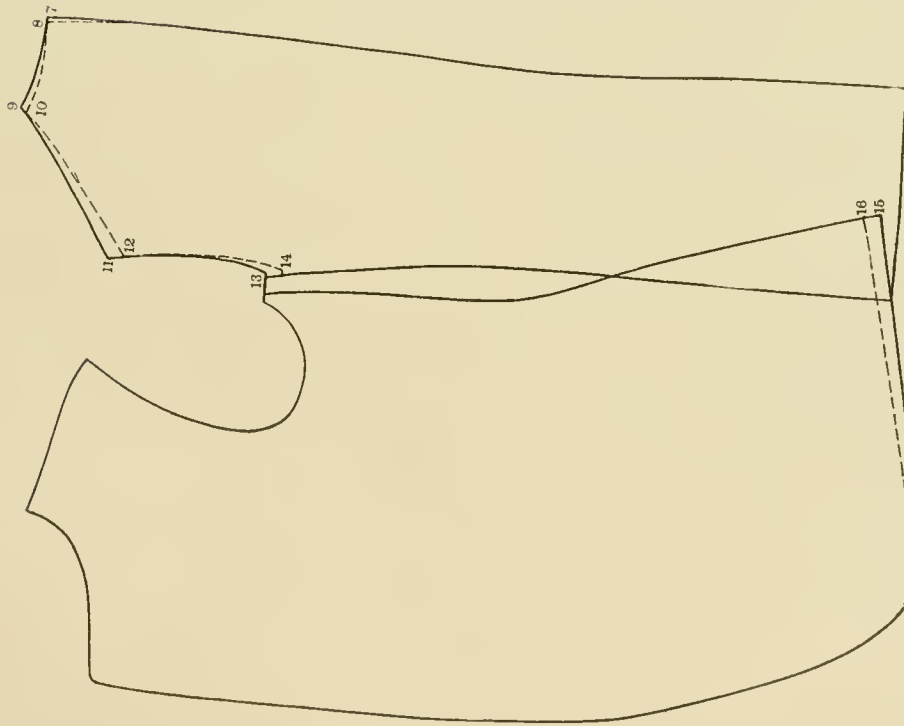

DIAGRAM 7.

## DIAGRAM 9

## SACK COAT FOR A FIGURE WITH A LARGE BLADE.

The measurements are the same for this coat as described for diagram 1, with the exception that the blade measure is 13 inches instead of  $12\frac{1}{2}$  inches. Square down and out from A.

From A to B is the scye depth plus  $\frac{1}{4}$  inch; C is waist length; C to D is 6 inches; A to E is full length; F is halfway between A and B; G is halfway between A and F; square out from G, B, C, D and E.

From C to 2 is  $\frac{1}{2}$  the indentation; E to 22 is  $\frac{1}{2}$  the distance of C to 2; draw a line from F to 2 and 2 to 22; this locates 1; from 1 to H is  $\frac{1}{2}$  breast; H to I is  $1\frac{3}{4}$  inches; I to J is  $\frac{3}{4}$  inch; K is halfway between 1 and H; from K to 23 is  $3\frac{1}{2}$  inches; square down from 23; this locates 21; from 21 to S is  $\frac{1}{2}$  waist; apply the blade measure from 1 to L which in this case is 13 inches and square up and down from L; this locates Q.

Point M is halfway between 1 and L; M to N is  $1\frac{1}{4}$  inches; square up from N to locate O; N to P is  $\frac{1}{2}$  breast; point 1 is halfway between M and N; from 22 to 7 is the same distance as 1 to 1; draw a line from 4 to 7; from A to 25 is  $\frac{1}{2}$  the distance of L to 23 or  $\frac{1}{2}$  of the blade increase; shape the center back from 25 into F.

From A to 8 is  $6\frac{3}{8}$  inches; 8 to 9 is  $1\frac{1}{2}$  inches; draw a line from A to 9; from 25 to 10 is  $\frac{1}{6}$  breast; square up from 10 to locate 11; draw a line from  $\frac{1}{4}$  inch below 11 to O and shape the back as shown; point T is halfway between Q and S; U is halfway between L and 1; draw a line from T through U up; from 25 to 11 and L to V is the strap measure plus  $\frac{3}{4}$  inch; draw a line from V to O; from V to Z is  $\frac{3}{8}$  inch less than the back shoulder width; drop the shoulder  $\frac{3}{8}$  inch below Z and shape the shoulder and arm-scye.

Now finish this coat in the same manner as described on diagram 3. This slight round that we have obtained at the center of back will bring the shoulder width up to the normal and will give just enough round to pocket the blade bone, and give it a clear side seam.

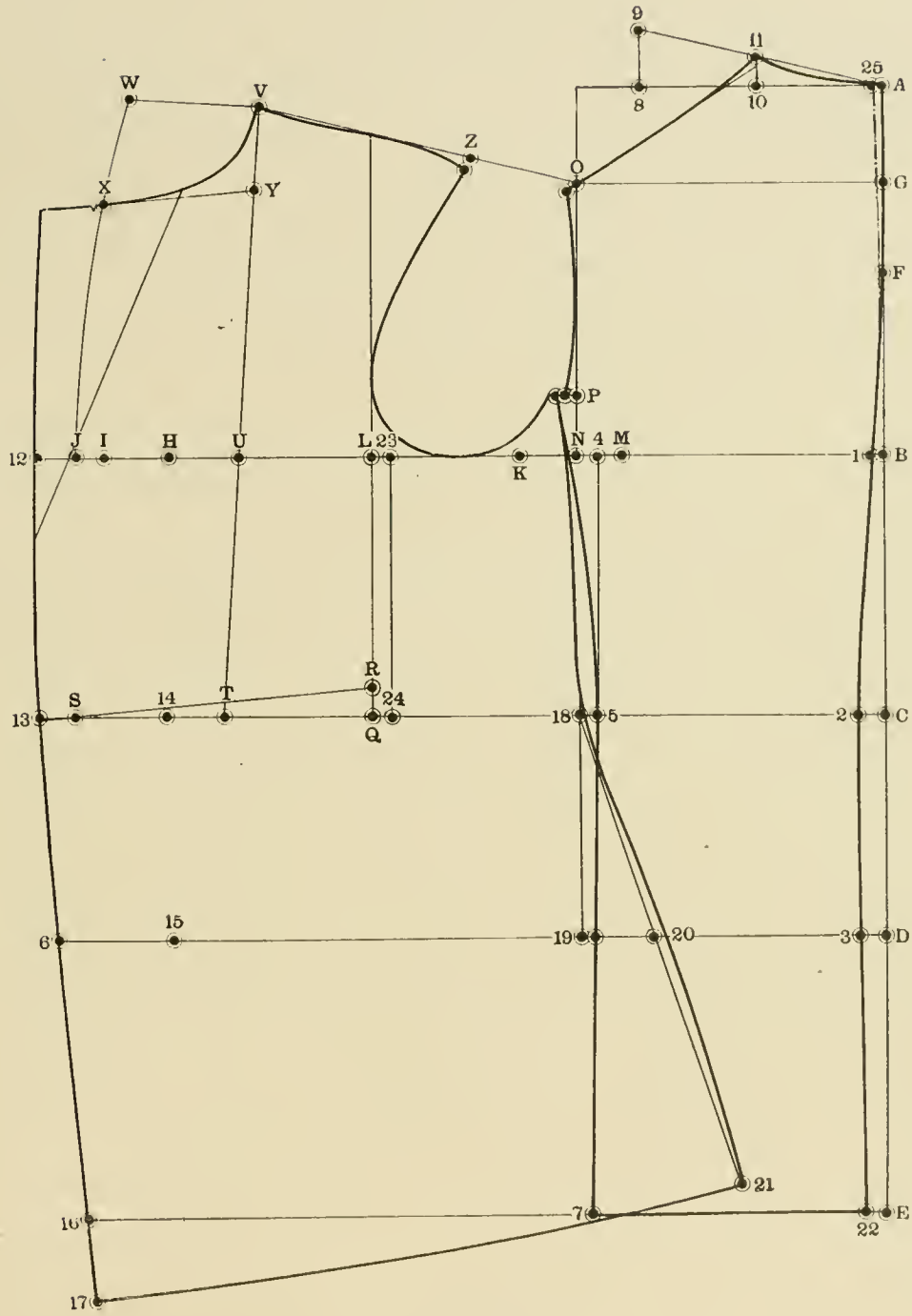

DIAGRAM 9.

## DIAGRAM 10

## SACK COAT FOR A FIGURE WITH A SMALL BLADE.

The measurements are the same for this coat as described for diagram 1, with the exception that the blade measure is 12 inches.

Square down and out from A.

From A to B is the scye depth plus  $\frac{1}{4}$  inch; C is waist length; C to D is 6 inches; A to E is full length; F is halfway between A and B; G is halfway between A and F; square out from G, B, C, D and E.

From C to 2 is  $\frac{1}{2}$  the indentation; E to 22 is  $\frac{1}{2}$  the distance of C to 2; draw a line from F to 2 and 2 to 22; from 1 to H is  $\frac{1}{2}$  breast; H to I is  $1\frac{3}{4}$  inches; I to J is  $\frac{3}{4}$  inch; K is halfway between 1 and H; from K to L is  $3\frac{1}{2}$  inches; square down from L to locate Q; from Q to S is  $\frac{1}{2}$  waist; apply the blade measure from 1 to 23 which is 12 inches and square up and down; this locates 21; M is halfway between 1 and 23; from M to N is  $1\frac{1}{4}$  inches; square up from N; N to P is  $\frac{1}{2}$  breast; point 4 is halfway between M and N; from 22 to 7 is the same distance as from 1 to 4; draw a line from 4 to 7.

From A to 25 is  $\frac{1}{2}$  the distance of 23 to L, in this case  $\frac{1}{4}$  inch; draw a line from 25 to F and shape the center seam; from 25 to 8 is  $6\frac{3}{8}$  inches; 8 to 9 is  $1\frac{1}{2}$  inches; draw a line from 25 to 9; 25 to 10 is  $\frac{1}{6}$  breast; square up from 10 to locate 11; draw a line from  $\frac{1}{4}$  inch below 11 to O and shape the back; point T is halfway between 21 and S; point U is halfway between 23 and 1; draw a line from T through U up.

From 25 to 11 and 23 to V is the strap measure plus  $\frac{3}{4}$  inch; draw a line from V to O; shape the shoulder and armseye as shown and finish in the same way as on diagram 3. The difference between this coat and the normal coat is that whilst the waist is applied from where the  $3\frac{1}{2}$  inches are squared down, the division for the shoulder point is always made by the blade measure.

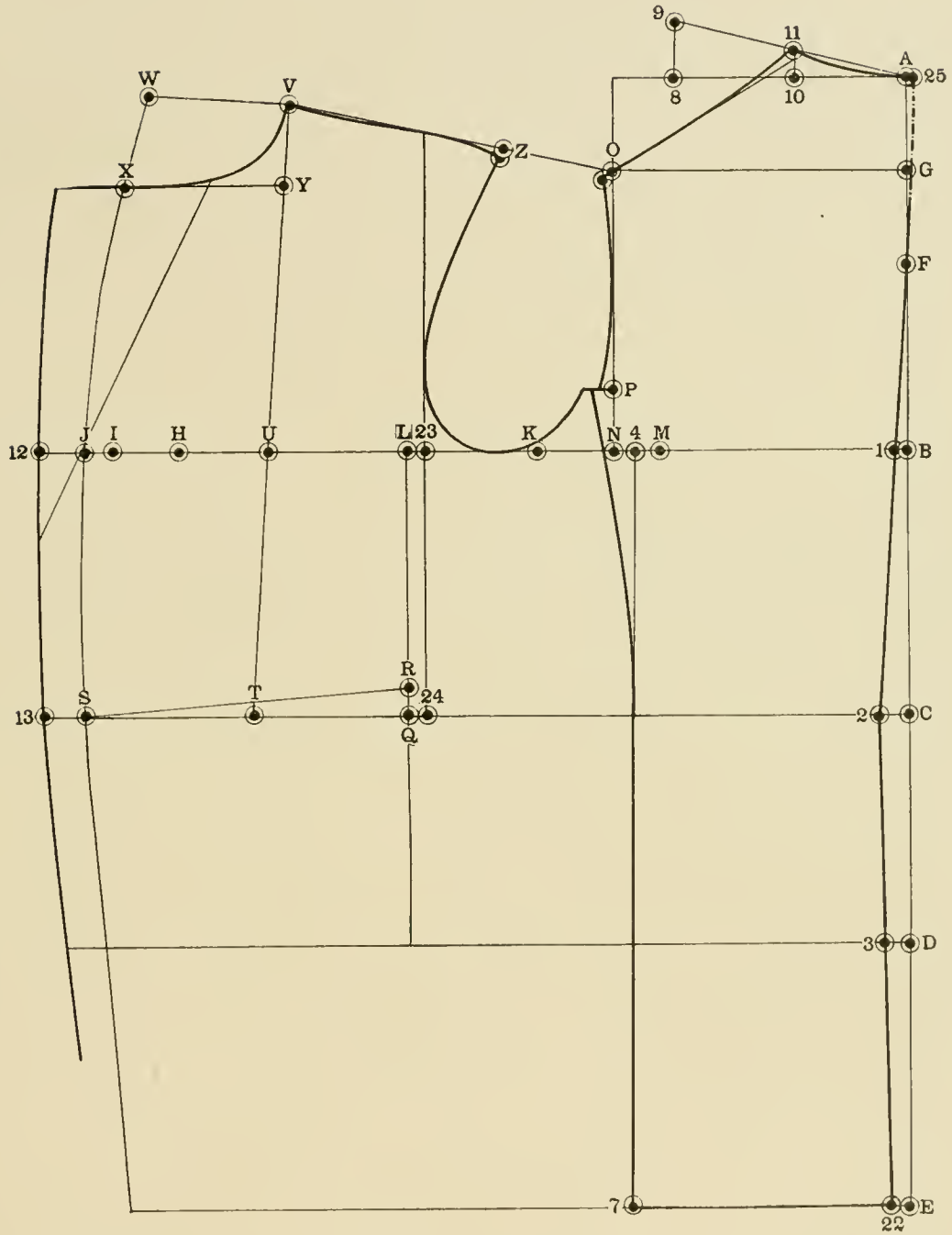

DIAGRAM 10.

## DIAGRAMS 11 AND 12

Diagram 11. To cause a small fold at the back of the arm, proceed as follows: after the backpart is cut out, add from A to B  $\frac{1}{4}$  or  $\frac{1}{2}$  inch and reshape the backpart as shown by broken line. This part of the back is to be drawn in and pressed back; there is no wing to be put in on that part of the back in making up coat.

Diagram 12. To make the shoulder narrower, place the backpart and forepart together at the shoulder seam and reshape as shown by the broken line.



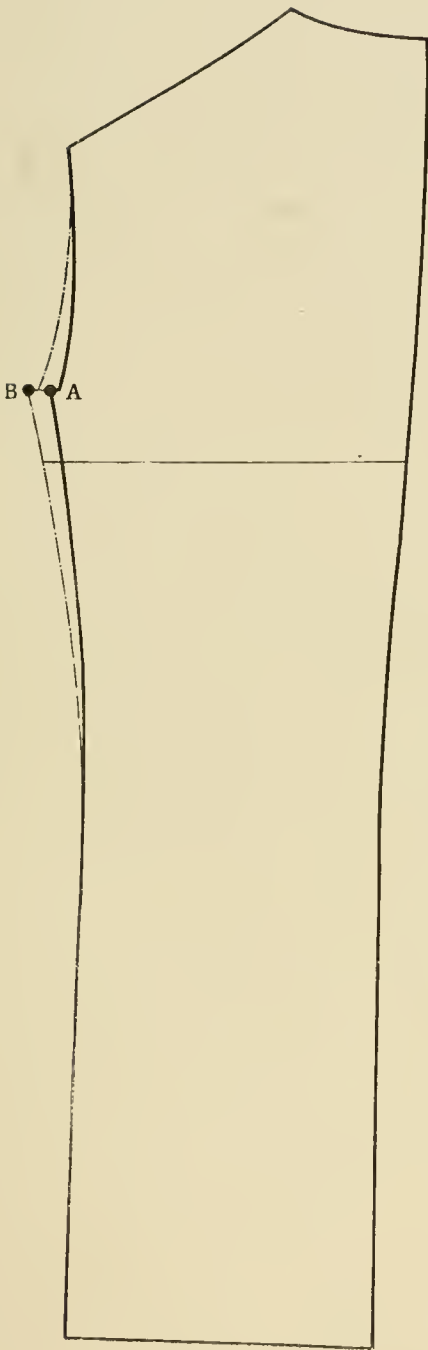

DIAGRAM 11.

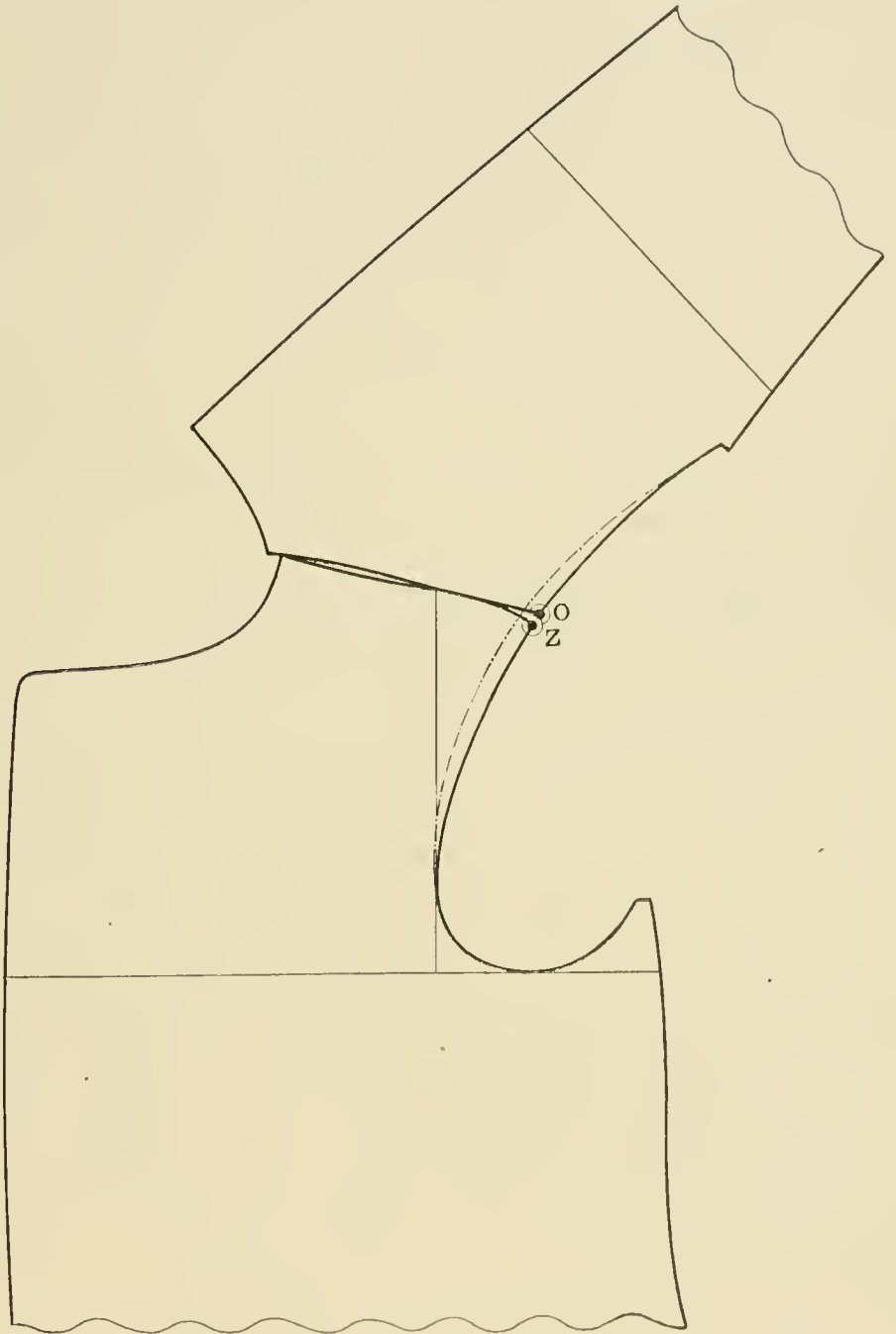

DIAGRAM 12.

## DIAGRAM 13

Diagram 13 shows how to increase the width of the shoulder. If an extremely wide shoulder is wanted, you may proceed as shown in this diagram. Add from A to B and 11 to 12 say  $\frac{3}{8}$  inch; add from V to W the same amount; add to the backpart from O to N about  $\frac{1}{2}$  inch or  $\frac{3}{4}$  inch; add from P to Q  $\frac{1}{4}$  inch and reshape the back part as per broken line. Now place the back shoulder alongside of the front shoulder and reshape the forepart as from Y to correspond with the back part as at N. This will increase the shoulder width without disturbing or interfering with any other part of the coat. Of course the armhole should be measured for the sleeve before the addition has been made.

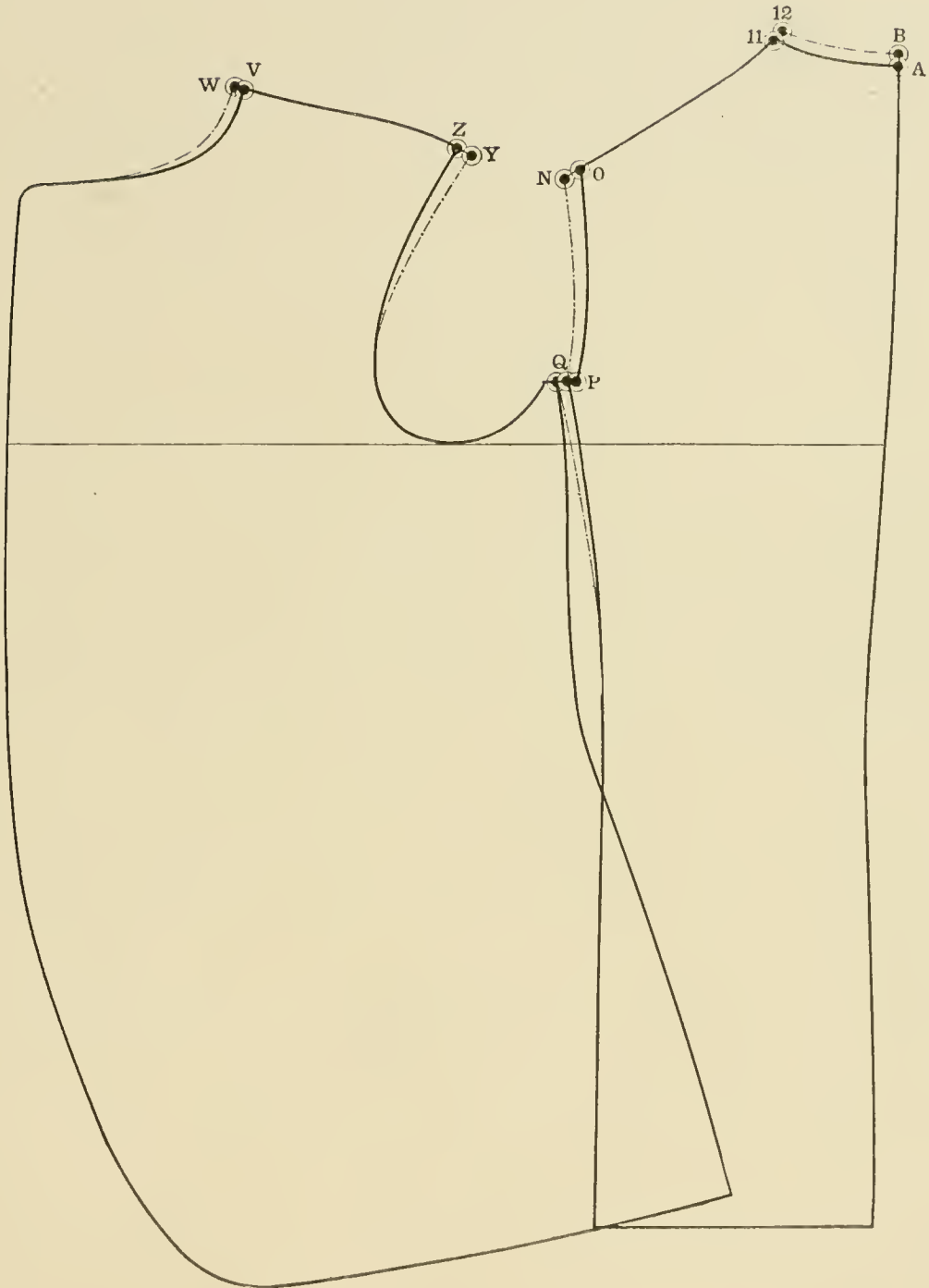

DIAGRAM 13.

## DIAGRAM 14

## SACK COAT FOR A SWAY-BACK FIGURE.

The measurements are as follows:

Indentation .....	2¼ inches.
Scye depth .....	9¾ inches.
Waist length .....	17 inches.
Full length .....	30½ inches.
Strap .....	12½ inches.
Overshoulder .....	17⅝ inches.
Blade .....	13 inches.
Breast .....	38 inches.
Waist .....	34½ inches.
Seat .....	40½ inches.

Square down and out from A.

From A to B is scye depth plus ¼ inch; C is natural waist length; C to D is 6 inches; A to E is full length; F is halfway between A and B; G is halfway between A and F; square out from G, B, C, D and E.

From C to 2 is ½ the indentation, in this case 1⅛ inches; E to 22 is ½ the distance of from C to 2; draw a line from F to 2 and 2 to 22 and shape the center of back; this locates 1; from 1 to H is ½ breast; H to I is 1¾ inches; I to J is ¾ inch; K is halfway between 1 and H; from K to L is 3½ inches; square down from L to locate Q; apply the blade measure from 1 to L which is 13 inches and square up; M is halfway between 1 and L; M to N is 1¼ inches; square up from N to locate O.

From N to P is ⅓ breast; point 4 is halfway between M and N; from 22 to 7 is the same distance as from 1 to 1; draw a line from 1 to 7; from A to 8 is 6¾ inches; 8 to 9 is 1½ inches; draw a line from A to 9; A to 10 is ⅓ breast; square up from 10 to locate 11; draw a line from ¼ inch below 11 to O and shape the back.

## THE FOREPART.

From Q to S is ½ waist; point T is halfway between Q and S; point U is halfway between L and I; draw a line from T through U up; from A to 11 and L to V is the strap measure plus ¾ inch; draw a line from V to O; from V to Z is ⅜ inch less than the back shoulder width; drop the shoulder ⅜ inch at Z and shape the shoulder and armscye as shown.

Square forwards from V by line T-U; V to W is ⅓ breast plus ½ inch; draw a rounding line from W to J; from W to X is ⅓ breast minus ½ inch; V to Y is ⅛ breast; from W to X, as explained before, is merely a change for lapel style; draw a line from Y to X and shape the gorge; from Q to R is the same distance as from C to 2, in this case 1⅛ inches; draw a line from R through S; from S to 13 is 1 inch; J to 12 is the same; square down from 13 by line R-S; this locates points 6 and 16.

From 16 to 17 is ⅓ breast; from 6 back to 15 is 3 inches; from 23 to 3 and 15 to 20 is the hip measure; from S back to 14 is 2½ inches; from 5 to 2 and 14 to 18 is the waist measure plus ¾ inch; draw a line from 18 through 20 down and shape the side of forepart; from 18 to 21 is the same distance as 5 to 7; shape the front edge, bottom of forepart and finish.

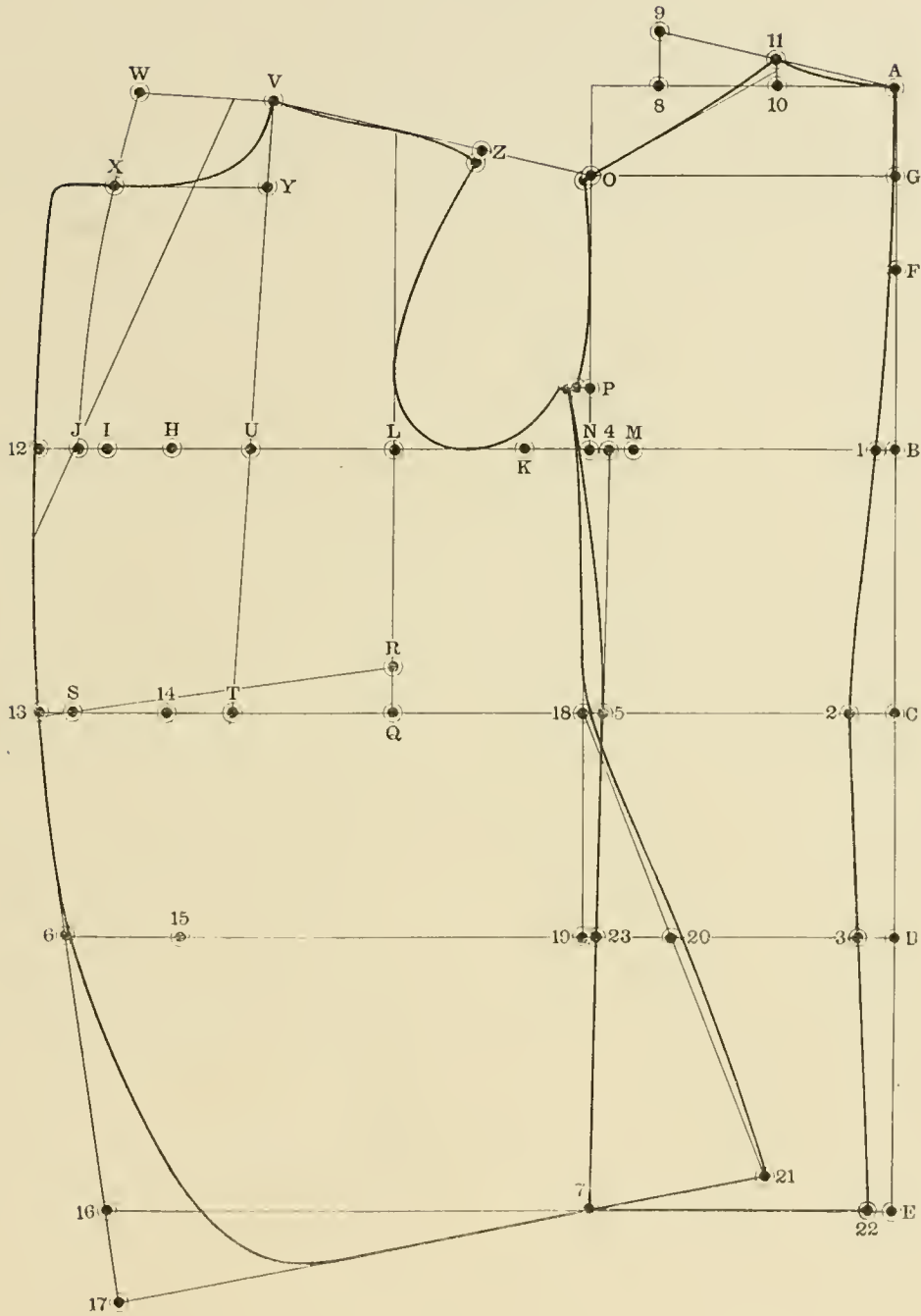

DIAGRAM 14.

## DIAGRAM 15

This diagram shows how to cut an increased or exaggerated size coat without disturbing the balance. The measurements for this coat are the same as given in the previous diagram, except that the waist indentation is normal.

Square down and out from A.

From A to B is the scye depth plus  $\frac{1}{4}$  inch; C is waist length; C to D is 6 inches; A to E is full length; F is halfway between A and B; G is halfway between A and F; square out from G, B, C, D and E.

From C to 2 is  $\frac{1}{2}$  the indentation,  $\frac{3}{4}$  inch; E to 22 is  $\frac{1}{2}$  the distance of from C to 2; draw a line from F to 2 and 2 to 22; shape the center seam; from 1 to 24 is  $\frac{1}{2}$  inch; 2 to 25 and 3 to 26 are the same; from 24 to H is  $\frac{1}{2}$  breast; H to I is  $1\frac{3}{4}$  inches; I to J is  $\frac{3}{4}$  inch; K is halfway between 24 and H; K to L is  $3\frac{1}{2}$  inches; square down from L to locate Q; apply the blade measure from 24 to L which is 13 inches and square up.

From L back to 27 is  $\frac{1}{4}$  inch or  $\frac{1}{2}$  the distance of from 1 to 24; point M is halfway between 1 and 27; M to N is  $1\frac{1}{4}$  inches; square up from N to locate O; point 4 is halfway between M and N; from 22 to 7 is the same distance as from 1 to 1; draw a line from 7 to 4; N to P is  $\frac{1}{2}$  breast; from A to 8 is  $6\frac{3}{8}$  inches; 8 to 9 is  $1\frac{1}{2}$  inches; draw a line from A to 9; A to 10 is  $\frac{1}{6}$  breast; square up from 10 to locate 11; draw a line from  $\frac{1}{4}$  inch below 11 to O and shape the back.

From Q to S is  $\frac{1}{2}$  waist; point T is halfway between Q and S; point U is halfway between L and I; draw a line from T through U up; from A to H and L to V is the strap measure plus  $\frac{3}{4}$  inch; draw a line from V to O; V to Z is  $\frac{3}{8}$  inch less the width of the back shoulder; drop the shoulder  $\frac{3}{8}$  inch at Z and shape the shoulder and armseye.

Square forwards from V by line T-U; V to W is  $\frac{1}{6}$  breast plus  $\frac{1}{2}$  inch; draw a rounding line from W to J; W to X is  $\frac{1}{6}$  breast; V to Y is  $\frac{1}{8}$  breast; draw a line from Y to X and shape the gorge; from Q to R is  $\frac{3}{4}$  inch; draw a line from R through S; S to 13 is 1 inch; J to 12 is the same; square down from 13 by line R-S; this locates points 6 and 16; from 16 to 17 is  $\frac{1}{8}$  breast; 6 to 15 is 3 inches; from 23 to 26 and 15 to 20 is the hip measure; from 20 back to 19 is 2 inches.

Square up from 19 to locate 18; draw a line from 18 through 20 down and shape the side of forepart; 18 to 21 is the same distance as from 5 to 7; finish this coat the same as the other coats. This kind of a pattern will produce an easy coat and it is specially recommended for tall, slender men.

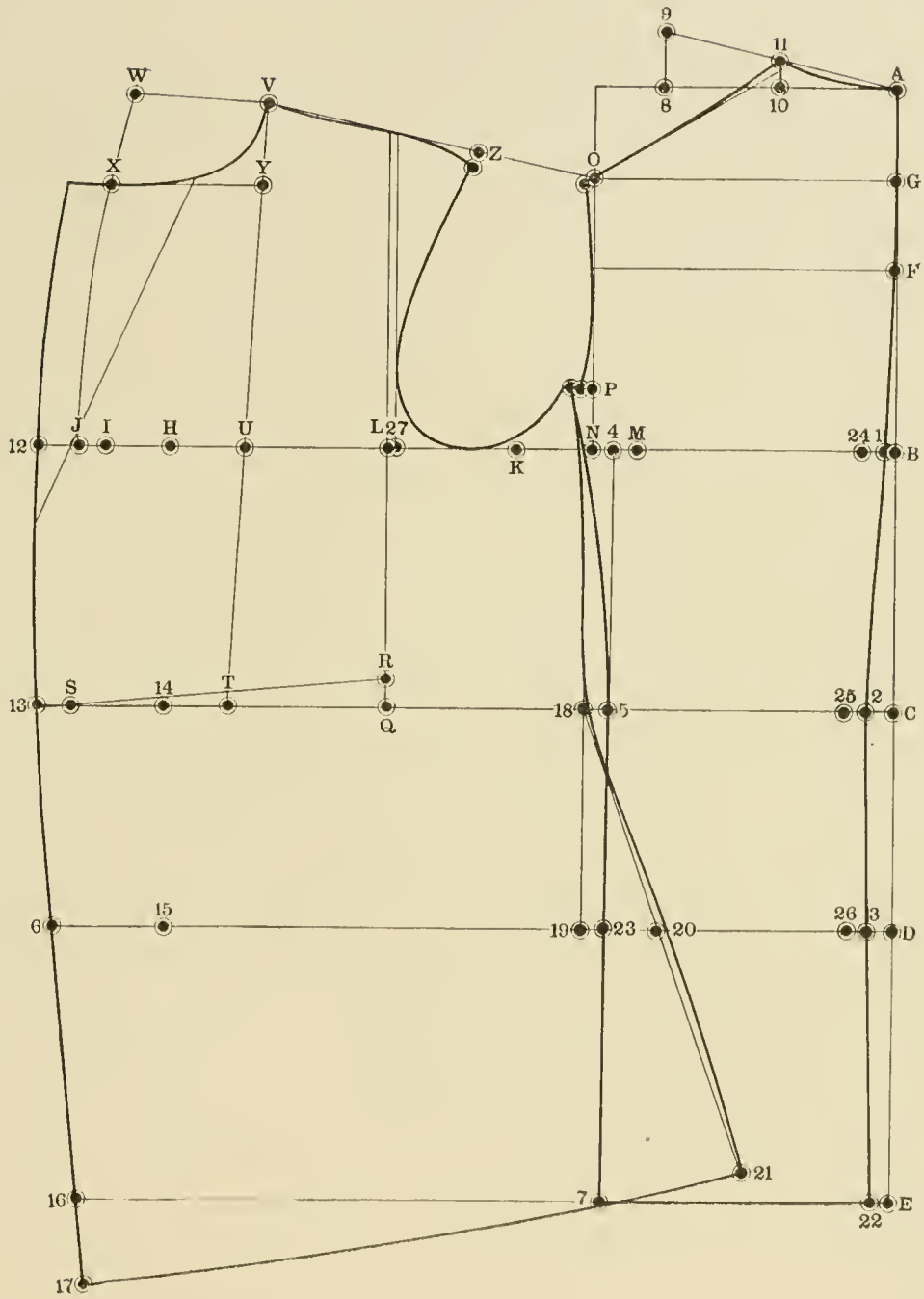

DIAGRAM 15.

## DIAGRAM 16

## FOUR-BUTTON STRAIGHT-HANGING SACK.

The measurements are as follows:

Scye depth .....	9½ inches
Waist length .....	17 inches
Full length .....	30½ inches
Strap .....	12¾ inches
Overshoulder .....	18 inches
Blade .....	13¾ inches
Breast .....	39 inches
Waist .....	35½ inches
Seat .....	41½ inches

Square down and out from A.

From A to B is the scye depth plus ¼ inch; C is waist length; C to D is 6 inches; A to E is full length; F is halfway between A and B; G is halfway between A and F; square out from G, B, C, D and E.

From C to 2 is ¾ inch, ½ indentation; draw a line from F to 2 and square down; this locates 22; from 1 to H is ½ breast; H to I is 1½ inches; I to J is ¾ inch; K is halfway between 1 and H; K to L is 3½ inches; square down from L to locate Q; apply the blade measure from 1 to L which is 13¾ inches and square up; M is halfway between 1 and L; M to N is 1¼ inches; square up from N to locate O; from N to P is ½ breast; 22 to 7 is the same distance as 1 to N; draw a line from 7 to N.

From A to 8 is 6¾ inches; 8 to 9 is 1½ inches; draw a line from A to 9; from A to 10 is ¼ breast; square up from 10 to locate 11; draw a line from 11 to O and shape the back as shown; from Q to S is ½ waist minus ½ inch; point T is halfway between Q and S; point U is halfway between L and 11; draw a line from T through U up; from A to 11 and L to V is the strap measure plus ¾ inch; draw a line from V to O; from V to Z is ¾ inch less than the back shoulder width; drop the shoulder ¾ inch at Z and shape the shoulder and armseye.

Square forwards from V by line T-U; V to W is ¼ breast plus ½ inch; draw a rounding line from W to J; from Q to R is ¾ inch; draw a line from R through S. Take note: this coat is cut ½ inch smaller at the front waist; this is done to reduce the front edge; from J to 12 is 1 inch; S to 13 is the same; square down from 13 by line R-S; this locates 16; 16 to 17 is ¼ breast.

Square down from 5; this locates 19; 19 to 20 is 2 inches; draw a line from 5 through 20 down and shape the side of forepart; from 5 to 21 is the same distance as from 5 to 7; shape the front edge, bottom of forepart and finish.



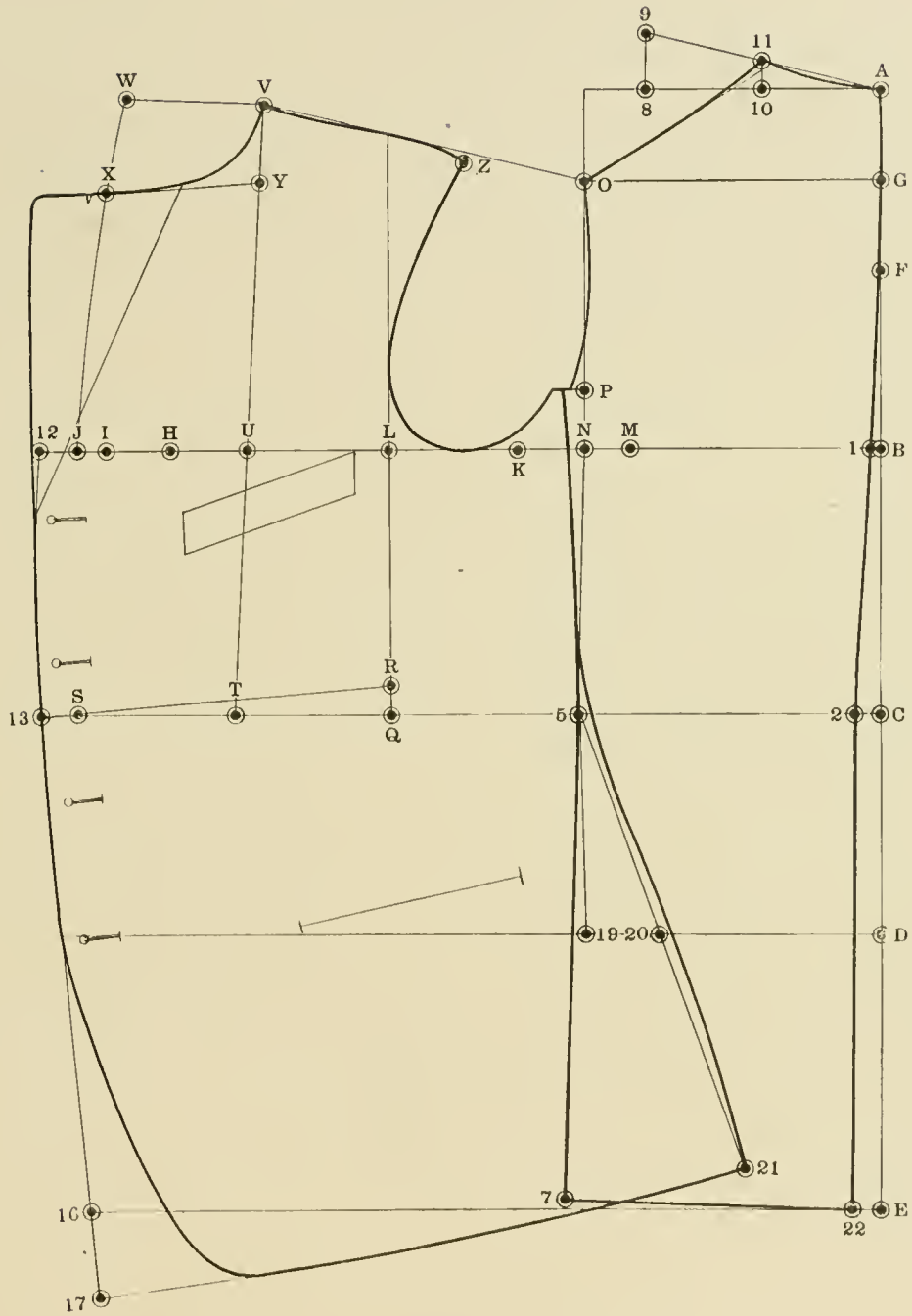

DIAGRAM 16.

## DIAGRAM 17

### BOX SACK COAT.

This diagram shows what is considered a box sack coat. Although not as full as a box overcoat, yet it will hang full from the shoulder down. The measurements are the same as shown on the previous diagram.

Square down and out from A.

From A to B is the scye depth plus  $\frac{1}{4}$  inch; C is waist length; C to D is 6 inches; A to E is full length; F is halfway between A and B; G is halfway between A and F; square out from G, B, C, D and E.

From C to 2 is  $\frac{3}{4}$  inch; draw a line from F through 2 down; this locates 22; from 1 to H is  $\frac{1}{2}$  breast; H to I is  $1\frac{1}{2}$  inches; I to J is  $\frac{3}{4}$  inch; K is halfway between 1 and H; from K to L is  $3\frac{1}{2}$  inches; square down from L to locate Q; apply the blade measure from 1 to L and square up; M is halfway between 1 and L; from M to N is  $1\frac{1}{4}$  inches; square up and down from N; this locates points O and 18; from 18 to 19 is  $1\frac{1}{2}$  inches; 18 to 20 is  $3\frac{1}{2}$  inches, or make the distance from 19 to 20, 5 inches.

From N to P is  $\frac{1}{2}$  breast; square out from P; P to 23 is  $\frac{1}{2}$  inch; draw lines from P through 19 to 7 and from 23 through 20 down; from A to 8 is  $6\frac{3}{8}$  inches; 8 to 9 is  $1\frac{1}{2}$  inches; draw a line from A to 9; A to 10 is  $\frac{1}{6}$  breast; square up from 10 to locate 11; draw line from  $\frac{1}{4}$  inch below 11 to O and shape the back.

From Q to S is  $\frac{1}{2}$  inch less than  $\frac{1}{2}$  waist; point T is halfway between Q and S; point U is halfway between L and I; draw a line from T through U up; from A to H and L to V is the strap measure plus  $\frac{3}{4}$  inch; draw a line from V to O; from V to Z is  $\frac{3}{8}$  inch less than the back shoulder width; drop the shoulder  $\frac{3}{8}$  inch at Z and shape the shoulder and armseye.

Square forwards from V by line T-U; from V to W is  $\frac{1}{6}$  breast plus  $\frac{1}{2}$  inch; draw a rounding line from W to J; W to X is  $\frac{1}{6}$  breast; V to Y is  $\frac{1}{8}$  breast; draw a line from Y through X and shape the gorge; from Q to R is 1 inch; draw a line from R to S; from S to 13 is 1 inch; J to 12 is the same; square down from 13 by line R-S; this locates point 16; from 16 to 17 is  $\frac{1}{8}$  breast; from 23 to 21 is the same distance as from 23 to 7; shape the bottom of forepart and finish hollowing the side seam of the forepart about  $\frac{1}{4}$  inch at the waist.

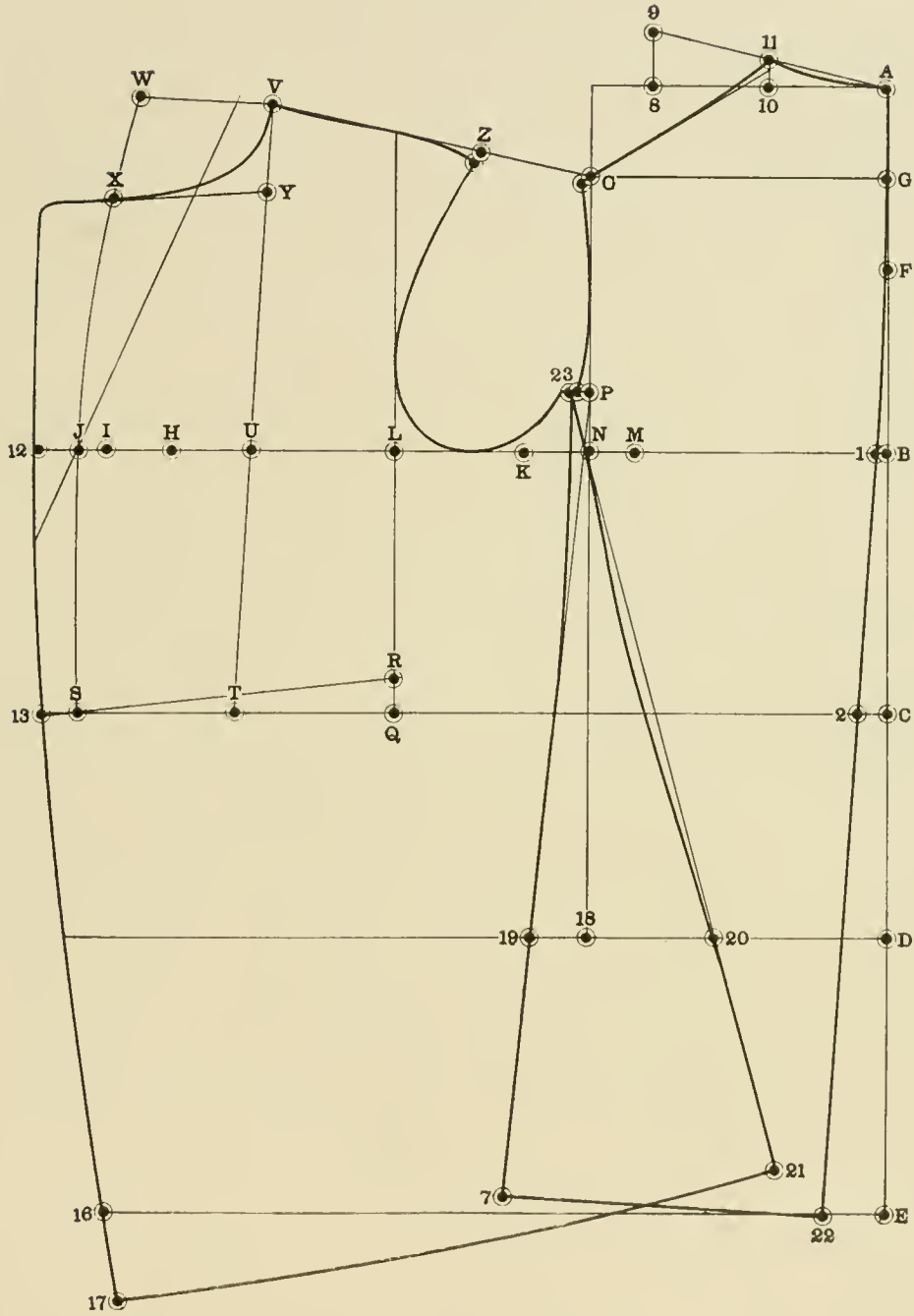

DIAGRAM 17.

## DIAGRAM 18

## THREE-BUTTON STOUT MAN'S SACK.

The measurements are as follows:

Indentation .....	1½ inches
Scye depth .....	9½ inches
Waist length .....	17 inches
Full length .....	31 inches
Strap .....	13 inches
Overshoulder .....	18¼ inches
Blade .....	13½ inches
Breast .....	40 inches
Waist .....	40 inches
Hip .....	42 inches

Square down and out from A.

From A to B is the scye depth plus ¼ inch; C is waist length; C to D is 6 inches; A to E is full length; F is halfway between A and B; G is halfway between A and F; square out from G, B, C, D and E.

From C to 2 is ½ the indentation; E to 22 is ½ the distance of C to 2; draw a line from F to 2 and 2 to 22; shape the center seam; from 1 to H is ½ breast; H to I is 1¾ inches; I to J is ¾ inch; square up a short line from J; K is halfway between 1 and H; from K to L is 3½ inches; square down from L to locate Q; apply the blade measure from 1 to L, which is 13½ inches and square up; M is halfway between 1 and L; from M to N is 1¼ inches; square up from N to locate O; from N to P is ½ breast; point 4 is halfway between M and N.

From 22 to 7 is the same distance as from 1 to 4; draw a line from 7 to 4; from A to 8 is 6¾ inches; 8 to 9 is 1½ inches; draw a line from A to 9; from A to 10 is ½ breast; square up from 10 to locate 11; draw a line from ¼ inch below 11 to O and shape the back; from Q to S is ½ waist; point T is halfway between Q and S; point U is halfway between L and I; draw a line from T through U up.

From A to 11 and L to V is the strap measure plus ¾ inch; draw a line from V to O; from V to Z is ¾ inch less than the back shoulder width; drop the shoulder ¾ inch at Z and shape the shoulder and armseye; square forwards from V by line T-U; square forwards from U by the same line; this locates 23; draw a line from W to 23; W to X is ½ breast; V to Y is ½ breast; draw a line from Y to X and shape the gorge.

From 23 to 12 is 1 inch; S to 13 is the same; Q to R is ½ the indentation; draw a line from R through S and square down from 13 by that line; this locates points 6 and 16; from 16 to 17 is ¾ breast; from 6 back to 15 is 3 inches; this being a stout man's coat and the seat measure being small, we apply the measurements in the following manner: from S back to 14 is 2½ inches; from 5 to 2 and 14 to 18 is the waist measure net. We always make it a rule to cut the stout man's or fat man's coat with as little addition as possible at the waist.

Square down from 18 to locate 19; from 19 to 20 is 2 inches; draw a line from 18 through 20 down and shape the side of forepart; from 18 to 21 is the same distance as from 5 to 7; draw a straight line from 21 to 17.

Now apply the actual seat measure from 24 to 3 and from 15 to 25; the distance from 25 to 20 is surplus and is to be taken out as will be shown in the next diagram; mark the pocket as usual after which split the forepart as from 30 to 24 and cut the pocket open as from 24 to 27 and from 27 down to 28. (Now see diagram 19).

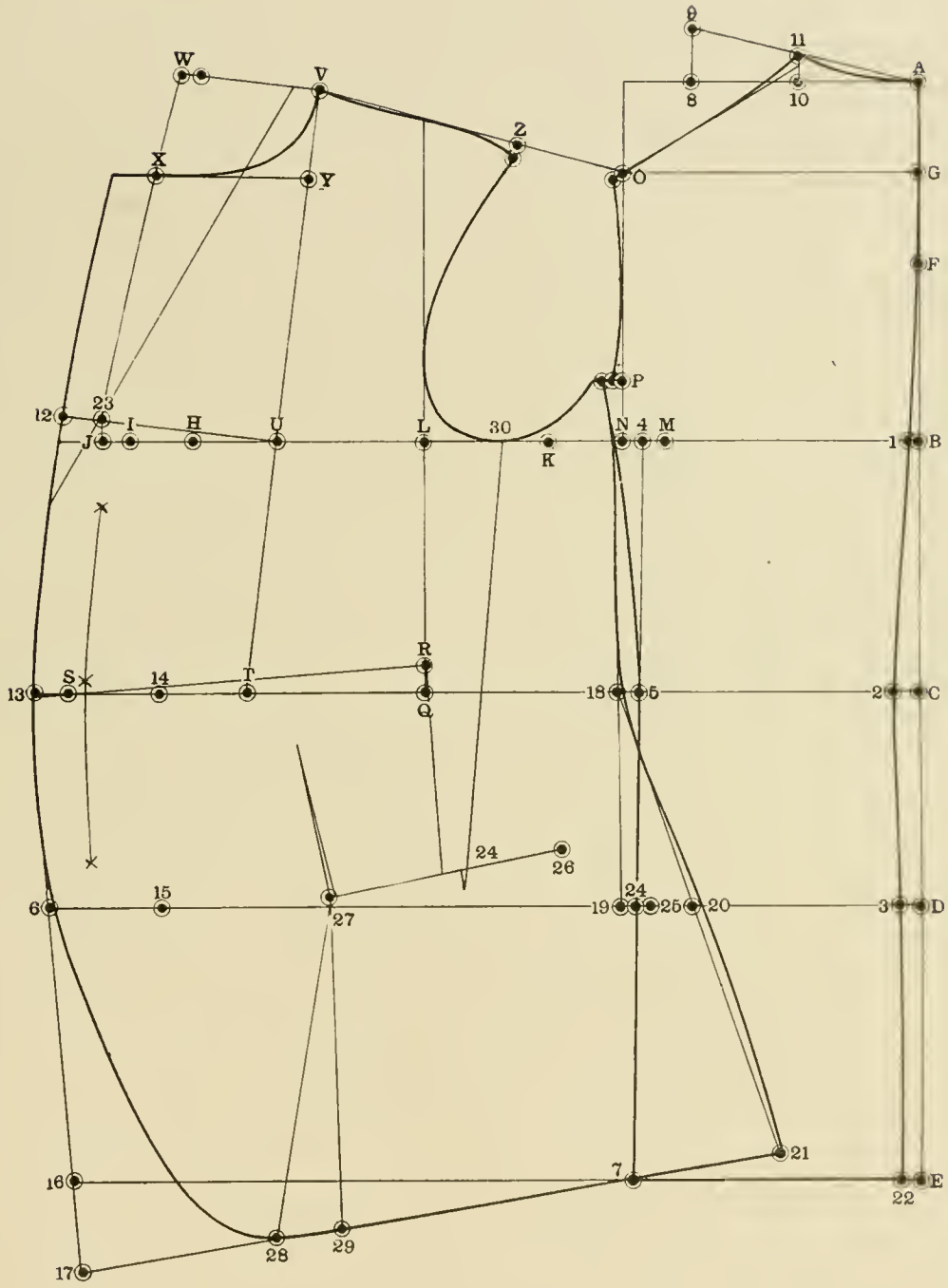

DIAGRAM 18.

## DIAGRAM 19

Place the two parts of the forepart together at 27, and keep the two edges close at 24; overlap them between 28 and 29 until the distance from 1 to 2 is the same as the surplus is on the previous diagram from 25 to 20; place the square to line 24-27 and square up to 30; make the distance from 27 to 30 about 3 inches; cut out a small V of about  $\frac{1}{8}$  inch between 27 and 30.

Now clip out a small piece as at 21; this will make up for the two seams which will be taken out at 27, and will flatten the forepart at the front corner of the pocket and throw a little fulness over the hip as is necessary for a man of this build.

Notice also the change that has taken place from the thin line to the heavy line at the bottom. After the front has been overlapped between 28 and 29, draw a straight line from 25 to the bottom of the side seam. This will give the amount of excess length that is required to go over the round part of the stomach.

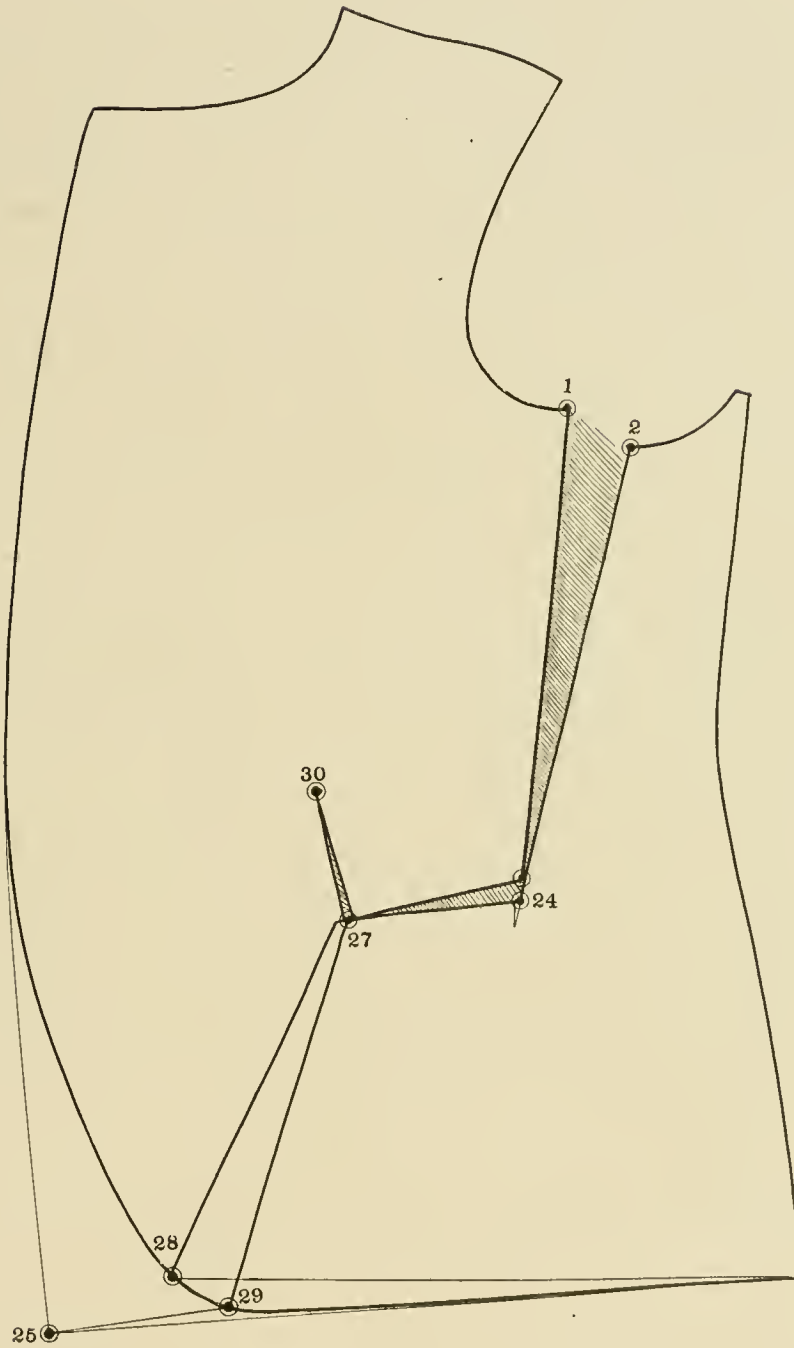

DIAGRAM 19.

## DIAGRAM 20

## THREE-BUTTON SACK COAT FOR A CORPULENT FIGURE.

The measurements are as follows:

Indentation .....	1 $\frac{1}{4}$ inches	Overshoulder .....	19 inches
Seye depth .....	9 $\frac{3}{4}$ inches	Blade .....	14 inches
Waist length .....	17 inches	Breast .....	42 inches
Full length .....	31 inches	Waist .....	45 inches
Strap .....	13 $\frac{1}{2}$ inches	Hip .....	47 inches

Square down and out from A.

From A to B is the seye depth plus  $\frac{1}{4}$  inch; C is waist length; C to D is 6 inches; A to E is full length; F is halfway between A and B; G is halfway between A and F; square out from G, B, C, D and E.

From C to 2 is  $5\frac{5}{8}$  inch,  $\frac{1}{2}$  the indentation; E to 22 is  $\frac{1}{2}$  the distance of C to 2; draw a line from F to 2, and from 2 to 22 and shape the center of back; from 1 to H is  $\frac{1}{2}$  breast; H to I is  $13\frac{1}{4}$  inches; I to J is  $3\frac{1}{4}$  inch; K is halfway between 1 and H; K to L is  $3\frac{1}{2}$  inches; square down from L to locate Q; apply the blade measure from 1 to L which is 14 inches and square up.

M is halfway between 1 and L; from M to N is  $1\frac{1}{4}$  inches; square up from N to locate O; N to P is  $\frac{1}{2}$  breast; point 4 is halfway between M and N; from 22 to 7 is the same distance as from 1 to 4; draw a line from 4 to 7; A to 8 is  $6\frac{3}{8}$  inches; 8 to 9 is  $1\frac{1}{2}$  inches; draw a line from A to 9; A to 10 is  $\frac{1}{6}$  breast; square up from 10 to locate 11; draw a line from  $\frac{1}{4}$  inch below 11 to O and shape the back.

From Q to S is  $\frac{1}{2}$  waist; point T is halfway between Q and S; point U is halfway between L and I; draw a line from T through U up; from A to 11 and L to V is the strap measure plus  $\frac{3}{4}$  inch; draw a line from V to O; V to Z is  $\frac{3}{8}$  inch less than the back shoulder width; drop the shoulder  $\frac{3}{8}$  inch at Z and shape the shoulder and armseye.

Square forwards from V by line T-U; V to W is  $\frac{1}{6}$  breast plus  $\frac{1}{2}$  inch, also square forwards from U by line T-U; square up from J to locate 23; draw a rounding line from W to 23; W to X is the depth of gorge desired; from V to Y is  $\frac{1}{8}$  breast; draw a line from Y to X and shape the gorge; Q to R is  $5\frac{5}{8}$  inch or  $\frac{1}{2}$  the indentation; draw a line from R through S; S to 13 is 1 inch; 23 to 12 is the same; square down from 13 by line R-S; this locates points 6 and 16.

From 16 to 17 is  $\frac{1}{8}$  breast; from S back to 14 is  $2\frac{1}{2}$  inches; from 5 to 2 and 14 to 5 is the waist measure net; square down from 5 to locate 19; from 19 to 20 is 2 inches; draw a line from 5 through 20 down and shape the side of forepart; from 5 to 21 is the same distance as from 5 to 7; draw a straight line from 21 to 17.

Now apply the hip measure from 19 to 3 and 15 to 18; from 18 to 20 is surplus and must be reduced the same as shown on diagrams 18 and 19.



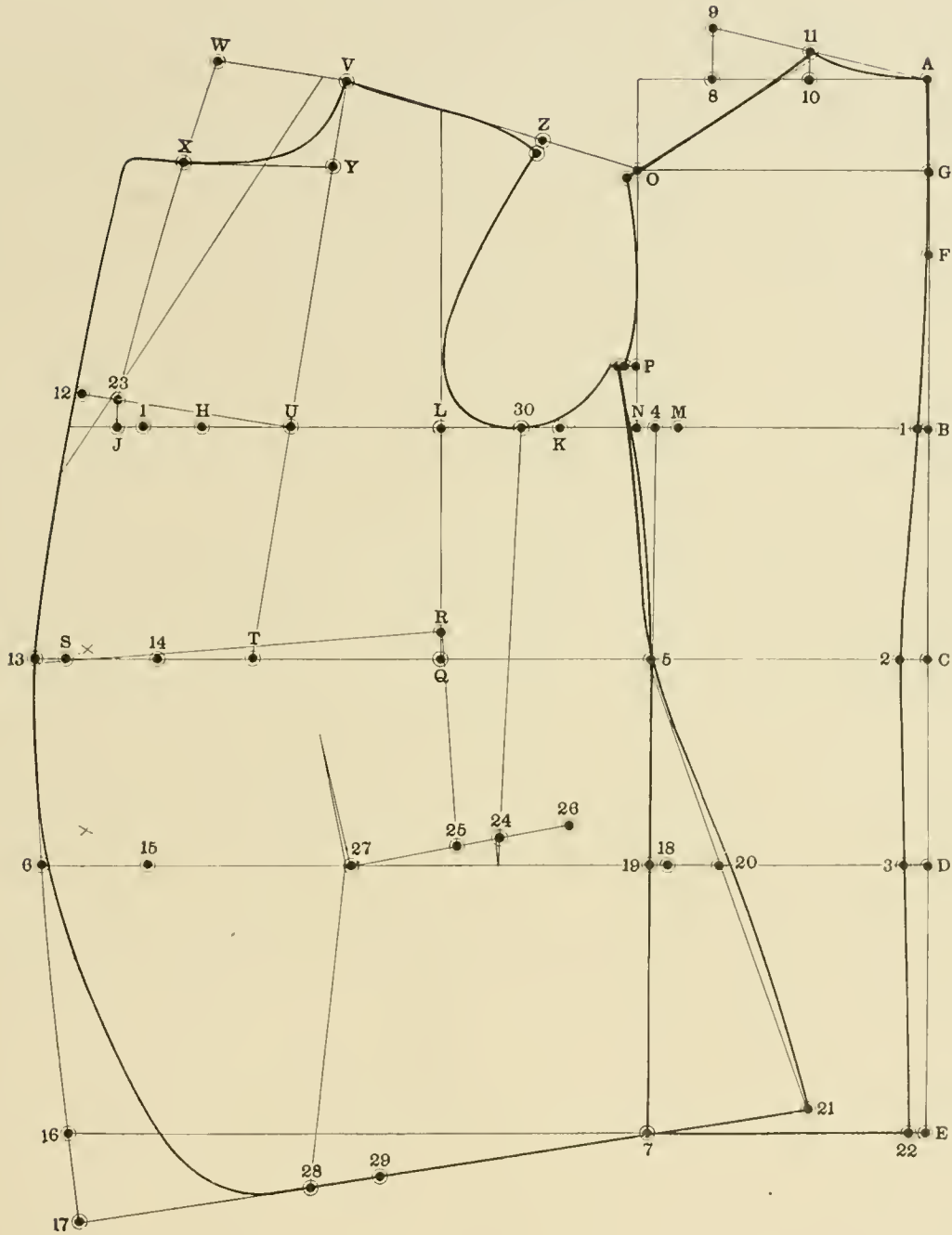

DIAGRAM 20.

## DIAGRAM 21

## DOUBLE-BREADED SACK COAT.

The measurements are as follows:

Indentation .....	1½ inches	Overshoulder .....	17½ inches
Scye depth .....	9¾ inches	Blade .....	13 inches
Waist length .....	17 inches	Breast .....	38 inches
Full length .....	30½ inches	Waist .....	34½ inches
Strap .....	12½ inches	Seat .....	40½ inches

Square down and out from A.

From A to B is the scye depth plus ¼ inch; C is waist length; C to D is 6 inches; A to E is full length; F is halfway between A and B; G is halfway between A and F; square out from G, B, C, D and E.

From C to 2 is ½ indentation which is ¾ inch; E to 22 is ½ the distance of C to 2; draw a line from F to 2 and 2 to 22 and shape the center seam; from 1 to H is ½ breast; H to I is 1¾ inches; I to J is ¾ inch; K is halfway between 1 and H; K to L is 3½ inches; square down from L to locate Q.

Apply the blade measure from 1 to L which is 13 inches and square up; M is halfway between 1 and L; M to N is 1¼ inches; square up from N; N to P is ½ breast; point 4 is halfway between M and N; from 22 to 7 is the same distance as from 1 to 4; draw a line from 4 to 7; from A to 8 is 6¾ inches; 8 to 9 is 1½ inches; draw a line from A to 9; A to 10 is ½ breast; square up from 10 to locate 11; draw a line from ¼ inch below 11 to O and shape the back.

From Q to S is ½ waist; point T is halfway between Q and S; point U is halfway between L and I; draw a line from T through U up; from A to 11 and L to V is the strap measure plus ¾ inch; draw a line from V to O; from V to Z is ¾ inch less than the back shoulder width; drop the shoulder ¾ inch at Z and shape the shoulder and arm-scye; square forwards from V by line T-U; from V to W is ½ breast plus ½ inch; draw a line from W to J; from W to X is ½ breast; V to Y is ⅛ breast; draw a line from Y to X and shape the gorge.

From Q to R is ¾ inch; draw a line from R through S; from S to 13 is ½ of the button stand desired, in this case the buttons are to be 6 inches from the edge, therefore the distance from S to 13 is 3 inches; square down from 13 by line R-S; J to 12 is the same as S to 13; shape the front edge.

From S back to 14 is 2½ inches; 6 to 15 is ½ inch less than 13 to 14; from 23 to 3 and 15 to 20 is the hip measure; 20 back to 19 is 2 inches; square up from 19 to locate 18; draw a line from 18 through 20 down and shape the side of forepart; from 18 to 21 is the same distance as from 5 to 7; from 16 to 17 is ⅛ breast; shape the bottom of forepart and finish.

Apply the waist measure from 5 to 2 and 14 to 18 and suppress the balance by taking out an underarm fish.

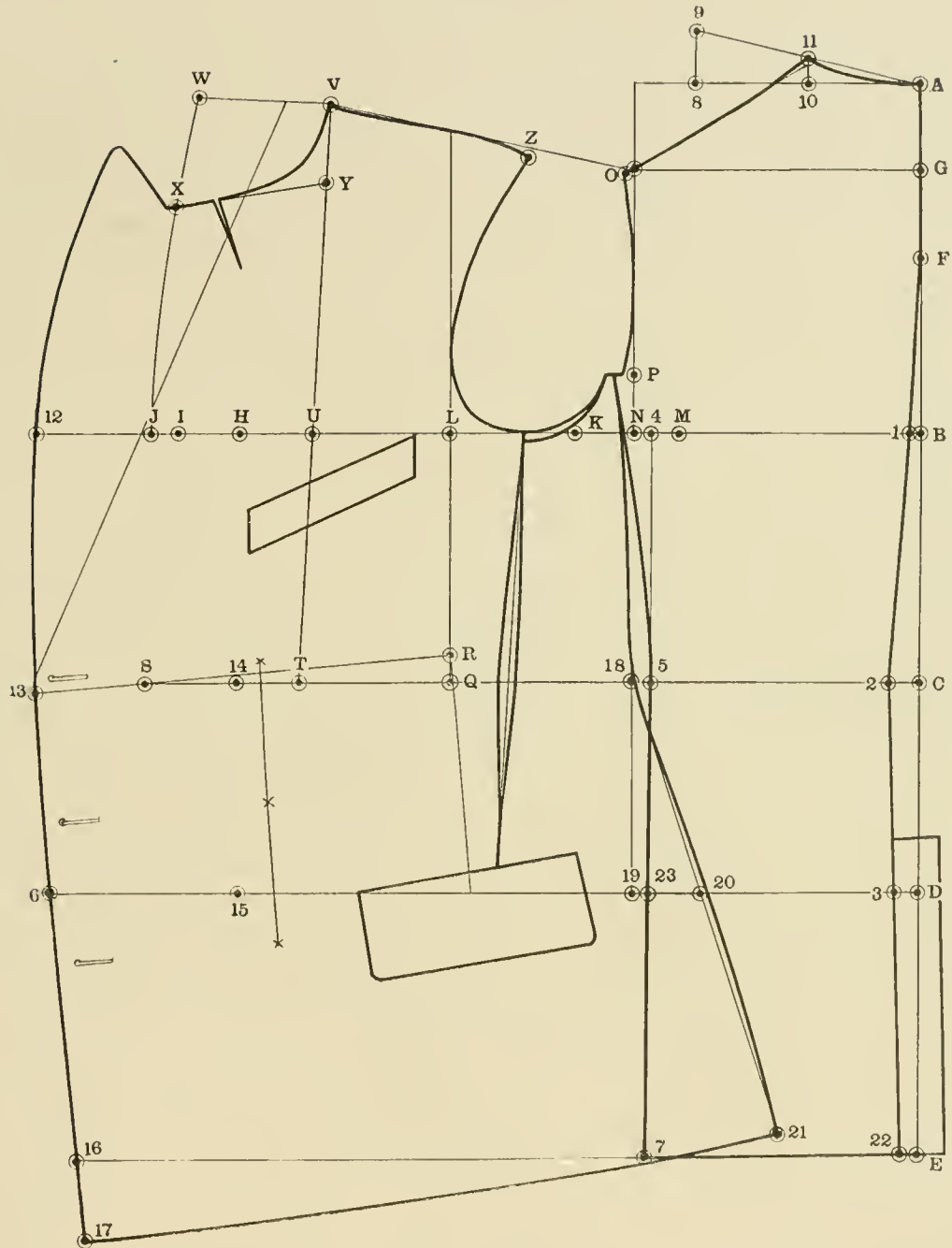

DIAGRAM 21

## DIAGRAM 22

## DOUBLE-BREADED SACK COAT FOR STOUT FIGURE.

The measurements are as follows:

Indentation .....	1½ inches	Overshoulder .....	19 inches
Scye depth .....	9¾ inches	Blade .....	14 inches
Waist length .....	17 inches	Breast .....	42 inches
Full length .....	31 inches	Waist .....	42 inches
Strap .....	13½ inches	Hip .....	41 inches

Square down and out from A.

From A to B is the scye depth plus ¼ inch; C is waist length; C to D is 6 inches; A to E is full length; F is halfway between A and B; G is halfway between A and F; square out from G, B, C, D and E.

From C to 2 is ½ indentation; E to 22 is ½ the distance of C to 2; draw a line from F to 2 and 2 to 22; shape the center seam; from I to H is ½ breast; H to I is 1¾ inches; I to J is ¾ inch; K is halfway between I and H; K to L is 3½ inches; square down from L to locate Q; apply the blade measure from I to L which is 14 inches and square up; M is halfway between I and L; M to N is 1¼ inches; square up from N to locate O.

From N to P is ½ breast; point 4 is halfway between M and N; 22 to 7 is the same distance as from I to 4; draw a line from 4 to 7; A to 8 is 6⅜ inches; 8 to 9 is 1½ inches; draw a line from A to 9; A to 10 is ⅙ breast; square up from 10 to locate 11; draw a line from ¼ inch below 11 to O and shape the back; Q to S is ½ waist; point T is halfway between Q and S; point U is halfway between L and I; draw a line from T through U up; A to 11 and L to V is the strap measure plus ¾ inch; draw a line from V to O; V to Z is ⅜ inch less than the back shoulder width; drop the shoulder ⅜ inch at Z and shape the shoulder and armseye.

Square forwards from V by line T-U; V to W is ⅙ breast plus ½ inch; square forwards from U by line T-U; square up from J to locate 23; draw a rounding line from W to 23; W to X is ⅙ breast; V to Y is ⅙ breast; draw a line from Y to X and shape the gorge; Q to R is ¾ inch or ½ the indentation; draw a line from R through S; S to 13 is ¾ inches; square down from 13 by line R-S; this locates points 6 and 16; 16 to 17 is ⅙ breast; 23 to 12 is the same distance as S to 13; shape the lapel and front edge.

From S back to 14 is 2½ inches; 6 back to 15 is ½ inch less than 13 to 14; 5 to 2 and 14 to 18 is the waist measure net; square down from 18 to locate 19; 19 to 20 is 2 inches; draw a line from 18 through 20 down and shape the side of forepart; 18 to 21 is the same distance as from 5 to 7; draw a straight line from 21 to 17.

Now apply the actual hip measure from 24 to 3 and 15 to 25; the distance from 25 to 20 in this case is 1¼ inches; split the forepart open as shown and manipulate in the same manner as shown in diagrams 18 and 19 and finish.

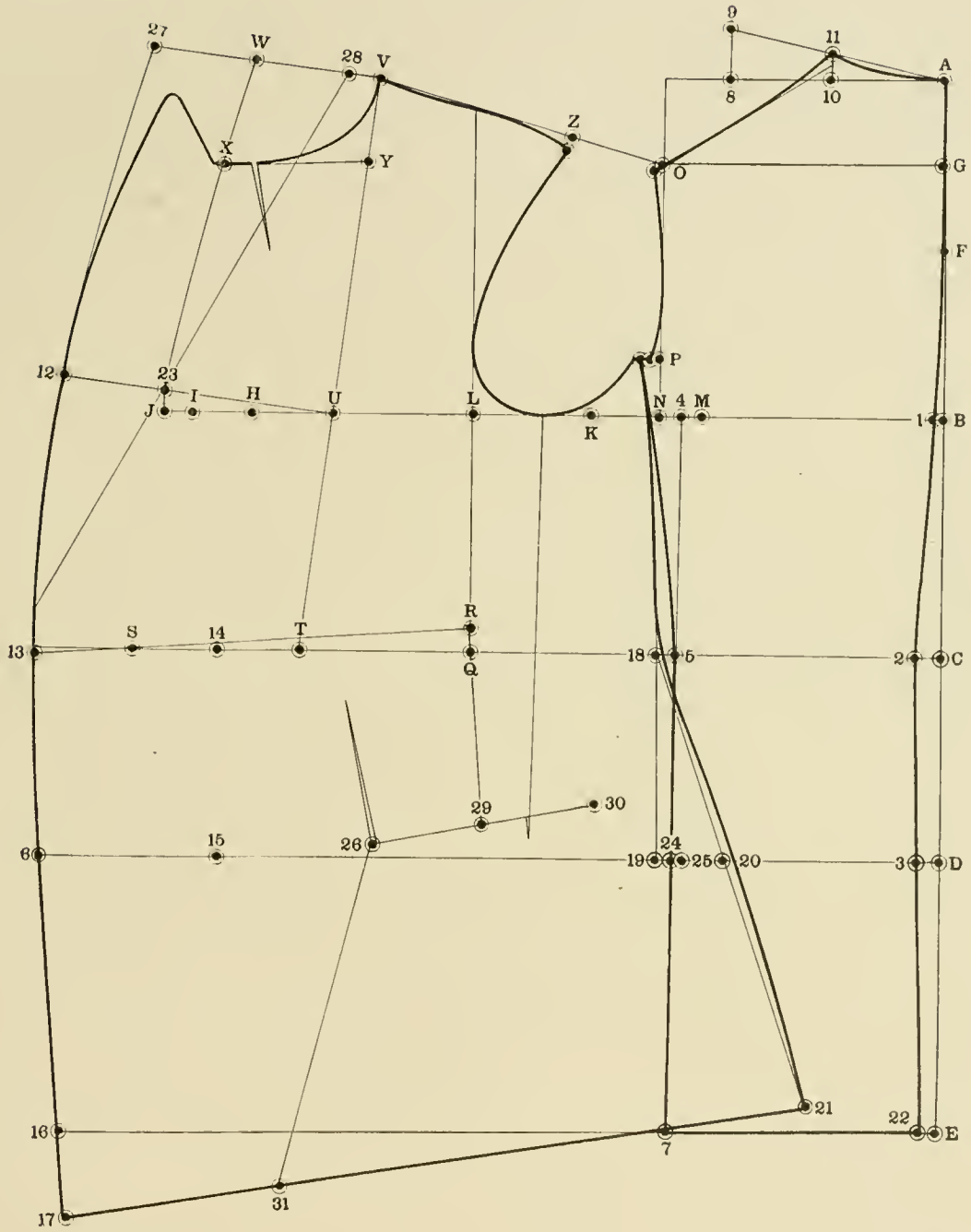

DIAGRAM 22.

## DIAGRAM 23

## THREE-BUTTON SACK COAT FOR A HUNCH-BACK.

The measurements are as follows:

Indentation .....	2 inches	Overshoulder .....	16 $\frac{3}{4}$ inches
Scye depth .....	8 inches	Blade .....	14 inches
Waist length .....	17 inches	Breast .....	40 inches
Full length .....	30 inches	Waist .....	38 inches
Strap .....	11 inches	Hip .....	41 inches

Square down and out from A.

From A to B is the scye depth plus  $\frac{1}{4}$  inch; C is waist length; C to D is 6 inches; A to E is full length; F is halfway between A and B; G is halfway between A and F; square out from G, B, C, D and E.

From C to 2 is  $\frac{1}{2}$  indentation. As we do not want this coat too shapely, we make the distance from E to 22 the same; draw a line from F to 2 and from 2 down to 22; from 1 to H is  $\frac{1}{2}$  breast; H to I is  $1\frac{3}{4}$  inches; I to J is  $\frac{3}{4}$  inch; K is halfway between 1 and H; K to 31 is  $3\frac{1}{2}$  inches; square down from 31 to locate Q; apply the blade measure from 1 to L which is 14 inches and square up and down; M is halfway between 1 and L; M to N is  $1\frac{1}{4}$  inches; square up from N to locate O; N to P is  $\frac{1}{2}$  breast; point 4 is halfway between M and N; 22 to 7 is the same distance as 1 to 4.

Draw a line from 4 to 7; from A to 8 is  $6\frac{3}{8}$  inches; 8 to 9 is  $1\frac{1}{2}$  inches; draw a line from A to 9; A to 10 is  $\frac{1}{8}$  breast; square up from 10 to locate 11; draw a line from  $\frac{1}{4}$  inch below 11 to O and shape the back; from Q to S is  $\frac{1}{2}$  waist; point T is halfway between 6 and S; point U is halfway between L and J; draw a line from T through U; from A to 11 and L to V is the strap measure plus  $\frac{3}{4}$  inch; draw a line from V to O.

Now apply the overshoulder measure plus 1 inch from 1 to 21 and L to 33; in this case the overshoulder measure up to line V-Z is  $1\frac{1}{4}$  inches short, therefore proceed as follows: from A to 26 is  $1\frac{1}{4}$  inches; 10 to 27 is the same; square up from 27 to locate 28; from O to 29 is  $1\frac{1}{4}$  inches; draw a line from 28 through 29; draw a line from 26 to F and reshape the back as shown, shaping the top of the back from 26 which is the upper line.

Measure the distance from 28 to 30 and make the distance from V to Z  $\frac{3}{8}$  inch less; shape the shoulder and armseye as shown; square forwards from V by line T-U; from V to W is  $\frac{1}{8}$  breast plus  $\frac{1}{2}$  inch; make the distance from W to X  $\frac{1}{8}$  breast more or less according to the kind of gorge desired; from V to Y is  $\frac{1}{8}$  breast; square forwards from Y and shape the gorge; Q to R is 1 inch; draw a line from R through S; S to 13 is 1 inch; J to 12 is the same; square down from 13 by line R-S; this locates 16; 16 to 17 is  $\frac{1}{8}$  breast; S back to 14 is  $2\frac{1}{2}$  inches; square down from 14 to locate 15; 19 to 3 and 15 to 20 is the seat measure.

From 5 to 2 and 14 to 18 is the waist measure; draw a line from 18 through 20 down and shape the side of forepart; shape the front edge, bottom of forepart and finish.

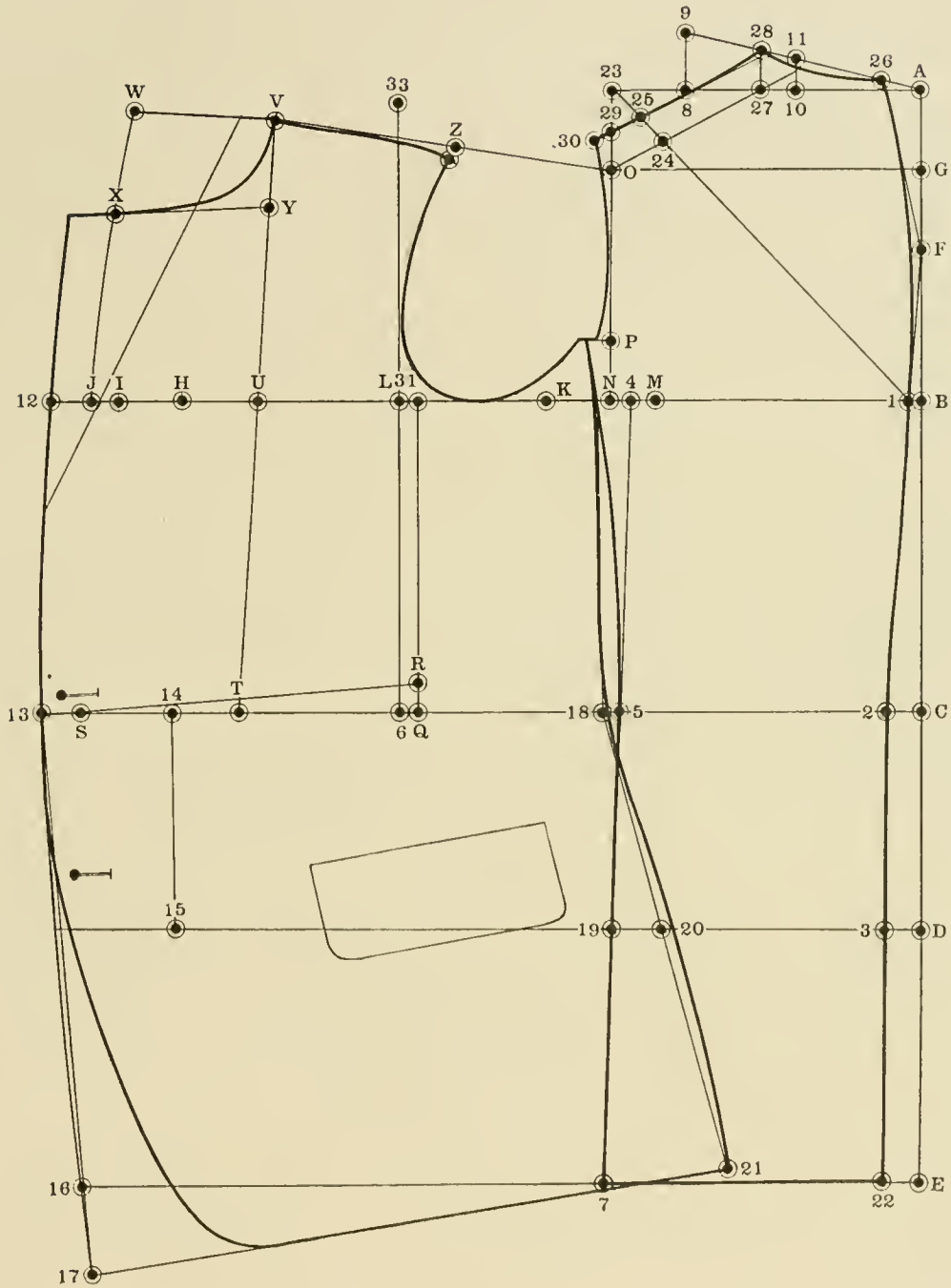

DIAGRAM 23.

DIAGRAM 24  
SHAWL COLLAR TUXEDO.

The measurements are as follows:

Indentation .....	1½ inches	Blade .....	12½ inches
Seve depth .....	9 inches	Breast .....	36 inches
Waist length .....	16½ inches	Waist .....	32 inches
Strap .....	12 inches	Seat .....	38 inches
Overshoulder .....	17 inches		

Square down and out from A.

From A to B is the seve depth plus ¼ inch; C is waist length; C to D is 6 inches; A to E is full length; F is halfway between A and B; G is halfway between A and F; square out from G, B, C, D and E; C to 2 is ½ indentation; E to 22 is ½ the distance of from C to 2; draw a line from F to 2 and 2 to 22, and shape the center of back.

From I to H is ½ breast; H to I is 1¾ inches; I to J is ¾ inch; K is halfway between I and H; K to L is 3½ inches; square down from L to locate Q; apply the blade measure from I to L which is 12½ inches and square up; M is halfway between I and L; from M to N is 1¼ inches; square up from N to locate O; from N to P is ½ breast; point 4 is halfway between M and N; 22 to 7 is the same distance as from I to I; draw a line from I to 7; A to 8 is 6⅜ inches; 8 to 9 is 1½ inches; draw a line from A to 9.

From A to 10 is ¾ breast; square up from 10 to locate H; draw a line from ¼ inch below H to O and shape the back; Q to S is ½ waist; point T is halfway between Q and S; point U is halfway between L and I; draw a line from T through U up; from A to 11 and L to V is the strap measure plus ¾ inch; draw a line from V to O; V to Z is ⅜ inch less than the back shoulder width; drop the shoulder ⅜ inch at Z and shape the shoulder and arm-seve.

Square forwards from V by line T-U; from V to 23 is 1¼ inches which is for the collar stand; 23 to W is the width of the collar desired plus ¼ inch for seam; draw a line from W through J; from Q to R is ¾ inch; draw a line from R to S and square down; this locates points 6 and 16; from 16 to 17 is ⅛ breast; from 6 back to 15 is 2 inches; 27 to 3 and 15 to 20 is the seat measure; from 20 back to 19 is 2 inches; square up from 19 to locate 18; draw a line from 18 through 20 and shape the side of forepart; from 18 to 21 is the same distance as from 5 to 7; draw a line from 21 to 17.

THE COLLAR

Draw a line from 6 through 23 up; from 23 to 24 is ¼ inch more than the top width of the back. From 24 to 25 is 1¼ inches; shape the collar stand from 25 to V and into the gorge; 24 to 26 is the width of the collar desired; shape the collar from 26 through J and 13 to 6.



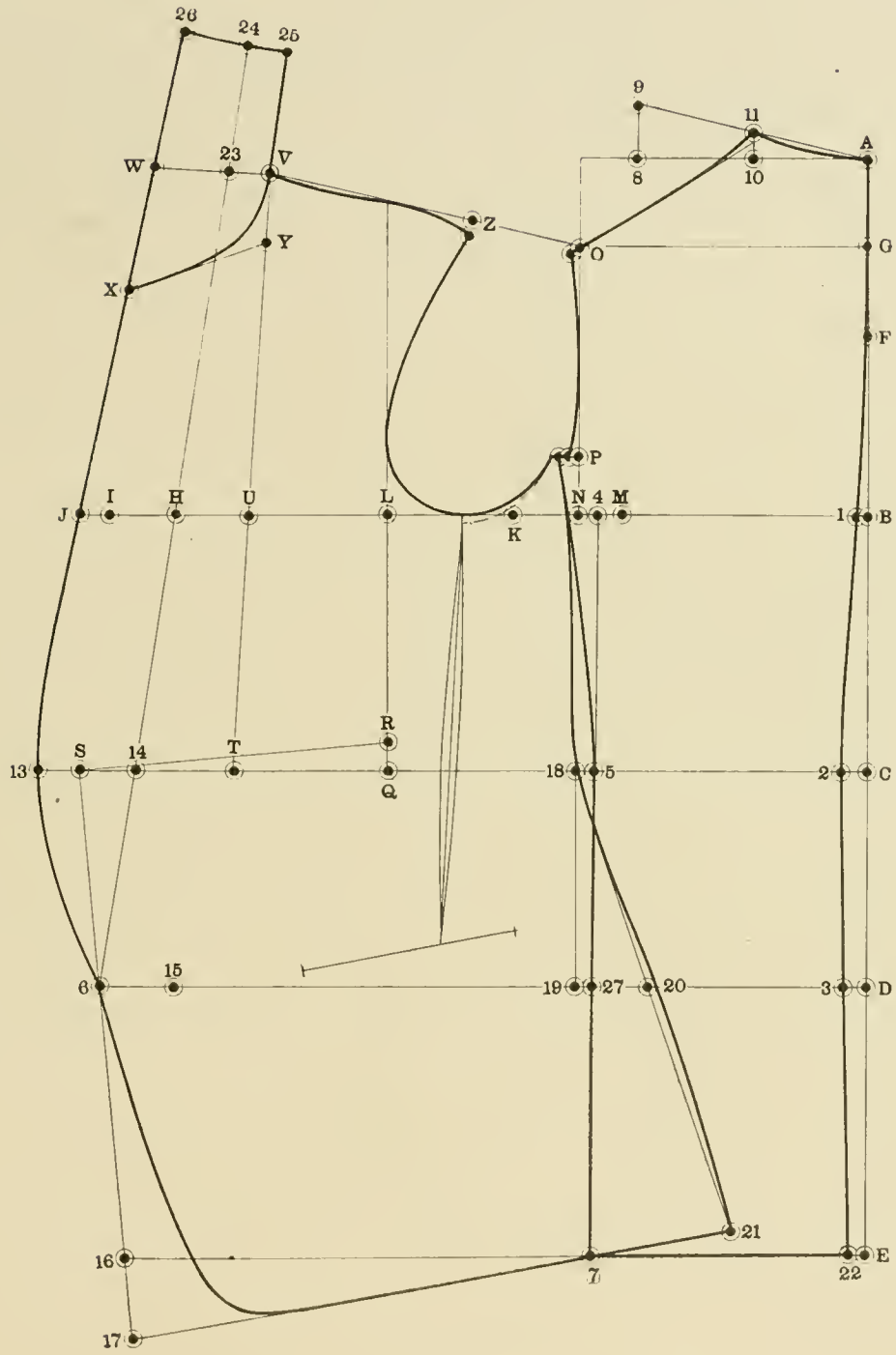

DIAGRAM 24.

DIAGRAM 25  
PEAKED LAPEL TUXEDO.

The measurements are as follows:

Indentation .....	1½ inches	Overshoulder .....	18¼ inches
Scye depth .....	9⅝ inches	Blade .....	13½ inches
Waist length .....	17 inches	Breast .....	40 inches
Full length .....	30½ inches	Waist .....	37 inches
Strap .....	13 inches	Seat .....	43 inches

Square down and out from A.

From A to B is the scye depth plus ¼ inch; C is waist length; C to D is 6 inches; A to E is full length; F is halfway between A and B; G is halfway between A and F; square out from G, B, C, D and E.

From C to 2 is ½ indentation; E to 22 is ½ the distance of from C to 2; draw a line from F to 2 and 2 to 22 and shape the center of back; from 1 to H is ½ breast; H to I is 1¾ inches; I to J is the same; K is halfway between 1 and H; K to L is 3½ inches; square down from L to locate Q; apply the blade measure from 1 to L which is 13½ inches and square up.

Point M is halfway between 1 and L; M to N is 1¼ inches; square up from N to locate O; N to P is ½ breast; point 4 is halfway between M and N; 22 to 7 is the same distance as from 1 to 4; draw a line from 4 to 7; from A to 8 is 6⅜ inches; 8 to 9 is 1½ inches; draw a line from A to 9; A to 10 is ⅓ breast; square up from 10 to locate 11; draw a line from ¼ inch below 11 to O and shape the back.

From Q to S is ½ waist; point T is halfway between Q and S; point U is halfway between L and I; draw a line from T through U up; from A to 11 and L to V is the strap measure plus ¾ inch; draw a line from V to O; V to Z is ⅜ inch less than the back shoulder width; drop the shoulder ⅜ inch at Z and shape the shoulder and armseye.

Square forwards from V by line T-U; V to 23 is 1¼ inches; V to W is ⅓ breast; draw a straight line from W to 1; W to X is ⅓ breast; V to Y is ⅛ breast; draw a line from Y to X and shape the gorge; from Q to R is ¾ inch; place the square to points R-S and square down; this locates point 6-16.

From 16 to 17 is ⅓ breast; now draw a line from 6 up through 23; from 23 to 24 is ¼ inch more than the top width of the back; 24 to 25 is 1¼ inches for the collar stand; 24 to 26 is the width of the collar desired; shape the collar and lapel and front edge; from 6 back to 15 is 2 inches; from 27 to 3 and 15 to 20 is the seat measure; 20 back to 19 is 2 inches; square up from 19 to locate 18; draw a line from 18 through 20 down and shape the side of forepart. From 18 to 21 is the same distance as 5 to 7; shape the bottom of forepart and finish.

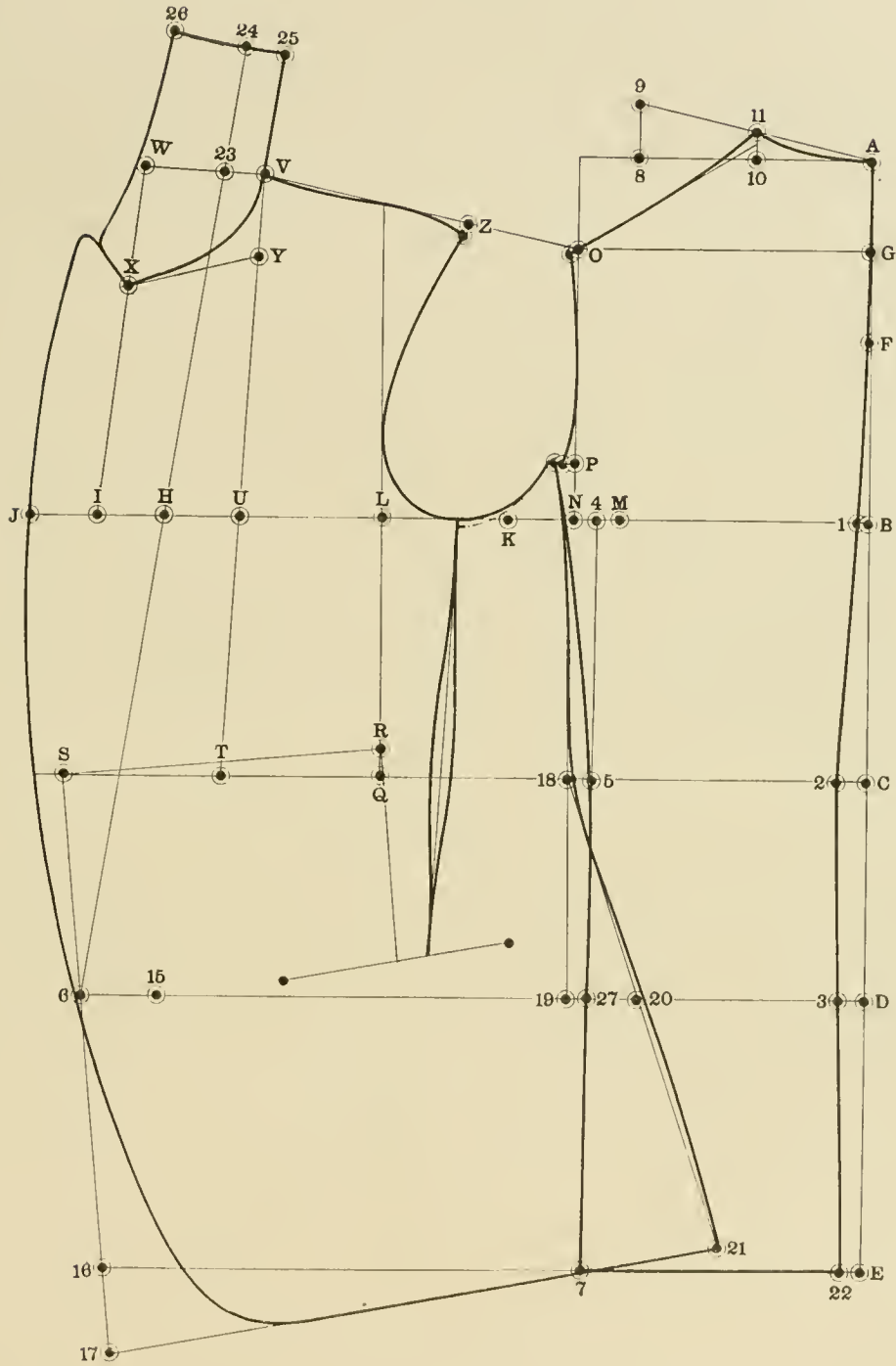

DIAGRAM 25.

## DIAGRAM 26

Some cutters imagine that if the side seam of the backpart has the same line as the side seam of the forepart that the coat will have a better line and will be easier to put together. If this is desired, proceed as follows: from 1 to M is  $\frac{1}{2}$  blade; M to N is  $1\frac{1}{4}$  inches; from 22 to 7 is the same distance as 1 to N; draw a line from M to 7; from N to 4 is  $\frac{1}{2}$  breast; from 4 to P is  $\frac{1}{2}$  inch; draw a straight line from P to 5; now shape the backpart as shown in this diagram.

From Q to S is  $\frac{1}{2}$  waist; S to 14 is  $2\frac{1}{2}$  inches; point 15 is 3 inches from the front edge; apply the waist measure from 5 to 2 and 14 to 18; apply the seat measure from 19 to 3 and 15 to 20; point 6 is halfway between 5 and 18; draw a line from 6 through 20; now cut out the backpart and place it to the side seam of the forepart as shown on this diagram and shape the front with the backpart.

## DIAGRAM 27

If a higher back seam is desired, proceed as shown on this diagram. Lay the backpart and forepart together, shoulder to shoulder; add from 11 to V  $\frac{1}{2}$  or  $\frac{3}{4}$  inch, and from O to Z the same and reshape as per broken line. The back shoulder seam should never be increased in any other way, because in this way only can the back receive the proper line at the neck.

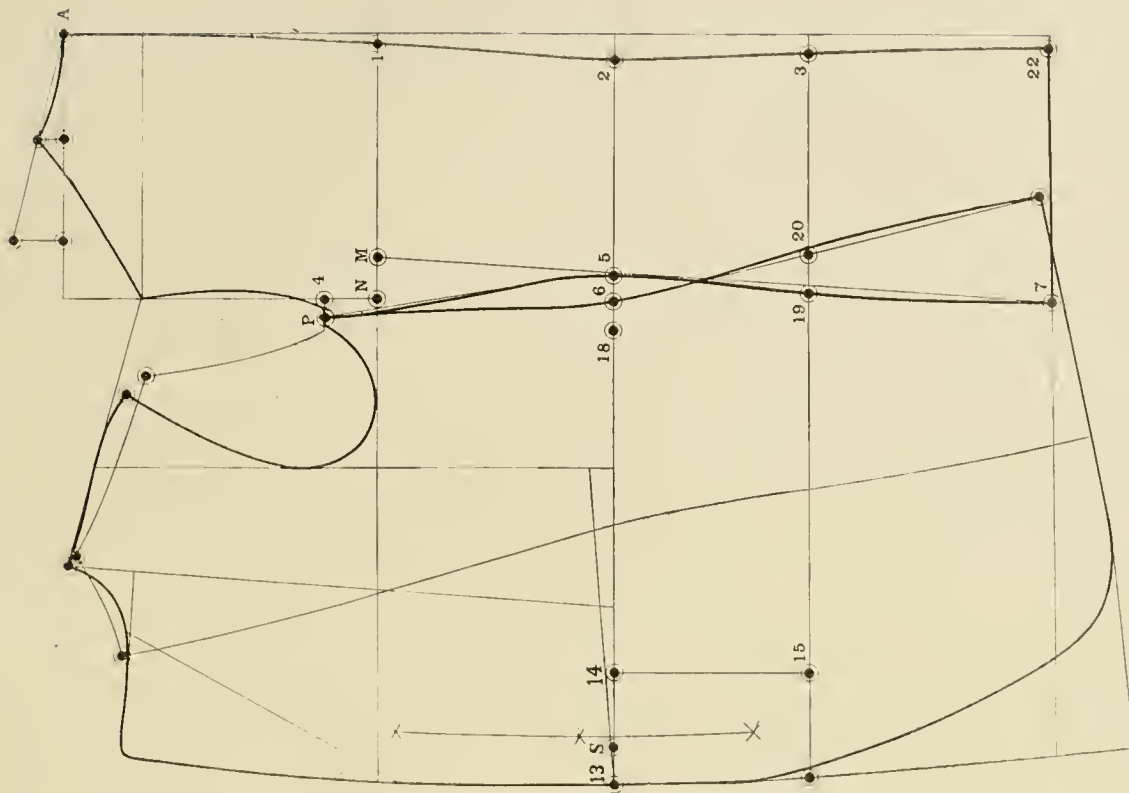

DIAGRAM 26.



DIAGRAM 27.

## DIAGRAM 28

## FROCK COAT.

The measurements are as follows:

Indentation .....	$1\frac{1}{2}$ inches	Overshoulder .....	$17\frac{5}{8}$ inches
Scye depth .....	$9\frac{3}{8}$ inches	Blade .....	13 inches
Natural waist length .....	$16\frac{3}{4}$ inches	Breast .....	38 inches
Fashionable waist length .....	$18\frac{1}{2}$ inches	Waist .....	$34\frac{1}{2}$ inches
Strap .....	$12\frac{1}{2}$ inches		

Square down and out from A.

From A to B is the scye depth plus  $\frac{1}{4}$  inch; C is natural waist length; D is fashionable waist length; F is halfway between A and B; G is halfway between A and F; square out from G, F, B, C, D and E.

From C to R is  $\frac{3}{4}$  inch,  $\frac{1}{2}$  indentation; draw a straight line from A through R to Q; this locates H; from H to I is  $\frac{1}{2}$  breast; I to J is  $1\frac{1}{2}$  inches; J to H is  $\frac{3}{4}$  inch; K is halfway between H and I; K to L is  $3\frac{1}{2}$  inches; square down from L to locate M; apply the blade measure from H to L which is 13 inches and square up; N is halfway between H and L; from N to O is  $1\frac{1}{4}$  inches; from A to 24 is the same distance as from H to O; draw a line from O to 24.

From A to T is  $6\frac{3}{8}$  inches; T to U is  $1\frac{1}{2}$  inches; draw a line from A to U; from A to V is  $\frac{1}{8}$  breast; square up from V to locate W; draw a line from  $\frac{1}{4}$  inch below W to P; from Q to S is  $\frac{1}{8}$  breast; this may be increased or decreased according to style; square up from S to E; from E to 22 is  $1\frac{3}{4}$  inches; sweep from 1 through 23 pivoting at 22; from 1 to 23 is the same distance as from 1 to 22; sweep from 1 to 22 pivoting at 23 and shape the side of backpart, taking care that your line is regular and has no digs; from M to 1 is  $\frac{1}{2}$  waist; square down from 1.

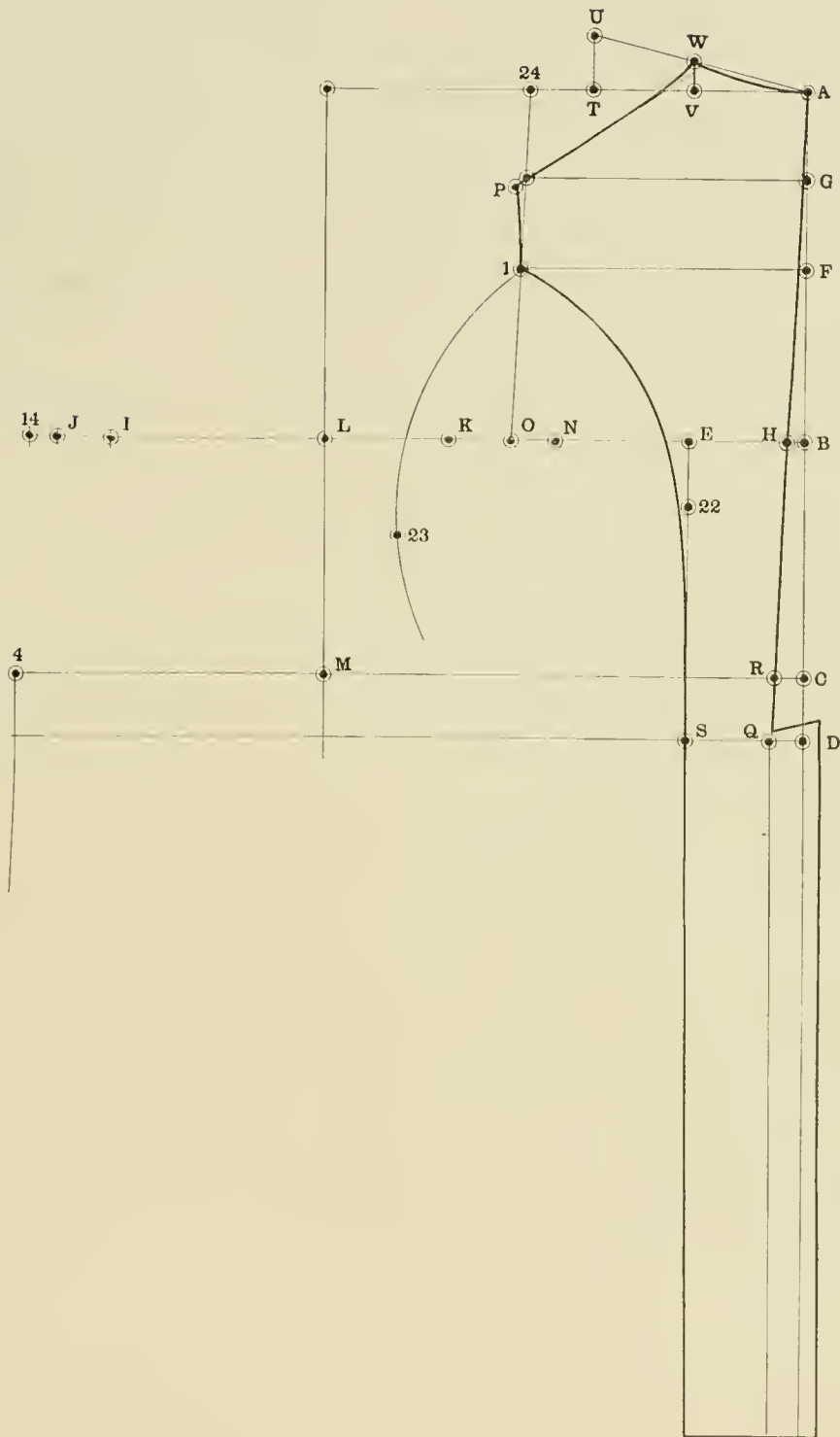

DIAGRAM 28.

## DIAGRAM 29

## THREE BUTTON FROCK, (CONTINUED)

From X to Y is  $1\frac{1}{4}$  inches; point Z is halfway between Y and M; square down from Y; from 1 to 2 is  $\frac{3}{4}$  inch; point 3 is  $\frac{1}{2}$  inch above the waist line; from O to K is  $\frac{1}{2}$  breast; shape the sidebody as shown; from 11 to 12 is  $\frac{1}{2}$  inch less than  $\frac{1}{6}$  breast; point 5 is halfway between M and 1; point 6 is halfway between L and J; draw a line from 5 through 6 up; from A to W and L to 7 is the strap measure plus  $\frac{3}{4}$  inch; draw a line from 7 to P; from 7 to 23 is  $\frac{3}{8}$  inch less than the back shoulder width; drop the shoulder  $\frac{3}{8}$  inch at 23 and shape the shoulder and armseye.

Square forwards from 7 by line 5-6; from 7 to 9 is  $\frac{1}{6}$  breast; draw a rounding line from 9 to 14; from 9 to 10 in this case is  $\frac{1}{6}$  breast; this gorge, the same as in a sack coat, may be raised or lowered in accordance with style; from 7 to 8 is  $\frac{1}{8}$  breast; draw a line from 8 to 10 and shape the gorge; from 4 back to 27 is  $2\frac{1}{4}$  inches where a fish is cut out at the waist; where no fish is cut out, the distance from 4 to 27 is to be  $1\frac{3}{4}$  inches. A fish may be cut out in all coats where the waist is 1 inches smaller than the breast or more, even 3 inches smaller than the breast, but where the waist is less than 2 inches smaller than the breast, it is advisable to leave the fish out, in which case the distance from 4 to 27 would be only  $1\frac{3}{4}$  inches.

From X to R, Z to Y and 27 to 21 is the waist measure net; draw a straight line from 3 to 12 and shape the side seam and bottom of forepart; from 11 to 15 is  $1\frac{1}{4}$  inches; 1 to 13 is the same; shape the lapel and front edge.

## THE SKIRT.

Go up from M to 20,  $\frac{3}{4}$  inch always; from 20 down to M is  $\frac{1}{2}$  indentation; this point may come above or below the waistline. Diagrams 39 and 40 will show how the spring changes for either a swayback or a flat-back. Place the square to wherever the indentation comes and square down from Y.

From Y to 25 is 9 inches; 25 to 26 is  $1\frac{1}{2}$  inches; draw a line from 22 through 26 down; from 22 to E is  $\frac{1}{4}$  inch more than from S to 17; from 12 to 18 is the same distance as from 22 to E; draw a line from 18 to E; point 16 is  $\frac{5}{8}$  inch below point 3; shape the top of skirt and round it  $\frac{5}{8}$  inch at 26. Now mark your buttonholes, shape off the lower part of the front of the skirt and finish.



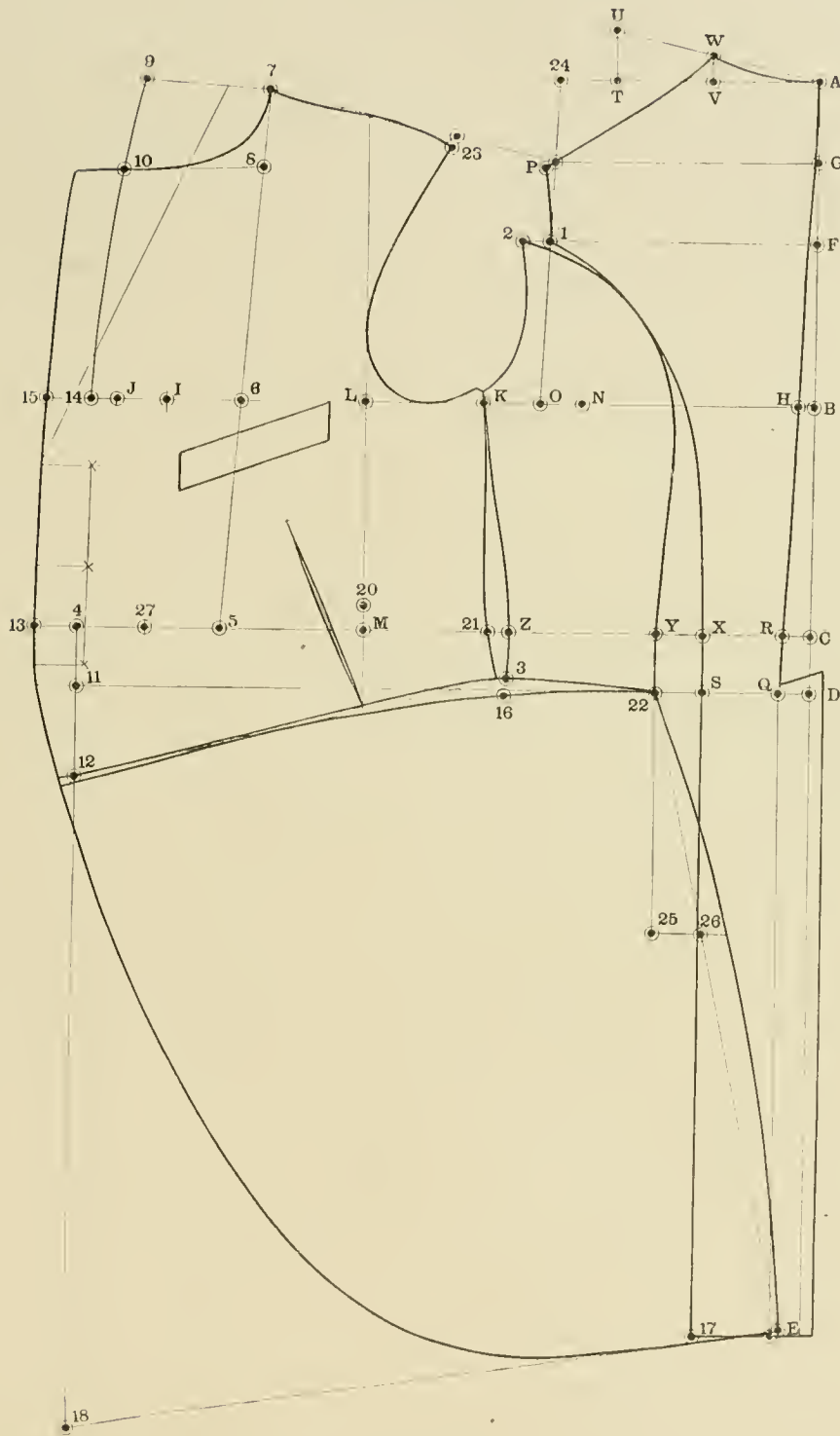

DIAGRAM 29.

## DIAGRAM 30

After the backpart is cut out and the strap and overshoulder is checked off, proceed as follows: Place the sidebody on the forepart and see that the forepart and sidebody meet at the breast line after they are sewn together, also hollow the forepart a scant  $\frac{1}{4}$  inch where the fish is placed, so that after the fish is sewn together, the seams should run as shown on Diagram 31.



DIAGRAM 30.

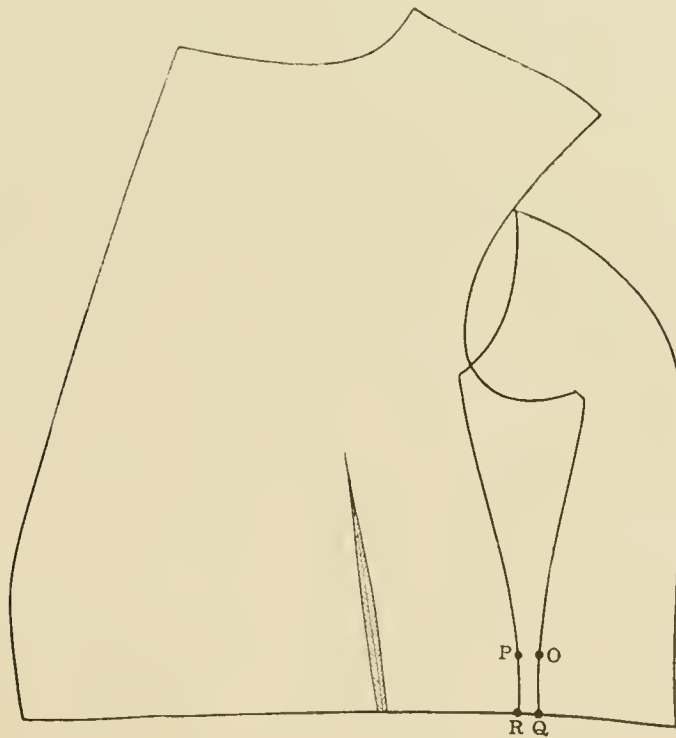

DIAGRAM 31.

## DIAGRAM 32

Should one shoulder be lower than the other proceed as follows; the frock coat should always be measured and cut for the high shoulder, as explained for sack coats, and the change should be made on the low side. If the difference between one shoulder and the other is  $\frac{1}{2}$  inch, lower your sidebody from F to G  $\frac{1}{2}$  inch and from D to E the same. Move point G of the sidebody up on a level with the forepart and shorten the side of the forepart from H to I to correspond with the sidebody. Reshape the sidebody as per broken line.

## DIAGRAM 33

In a case of the body leaning over to one side the change is made the same as in sack coats. After the pattern has been cut for the high side, copy the original pattern and proceed as shown on this diagram. Split the pattern as from A to the center of backpart and from A to the front edge; overlap the forepart as from A to B and overlap the backpart and sidebody from A to C.

**Notice:**—This change should always be made on the sidebody and backpart together, after which straighten the center seam of the backpart and fill in slightly at the sides.

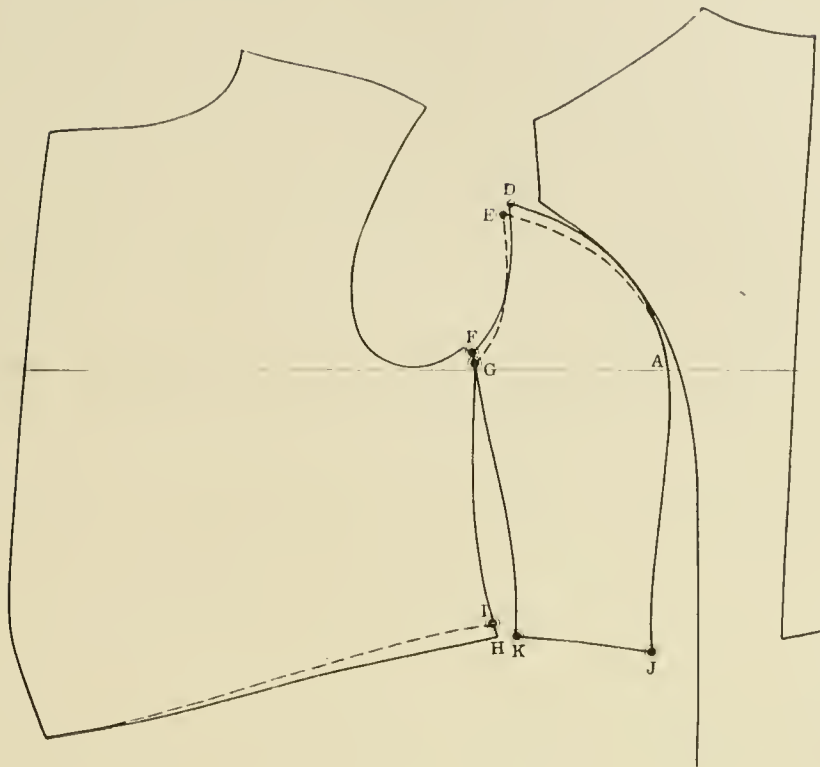

DIAGRAM 32

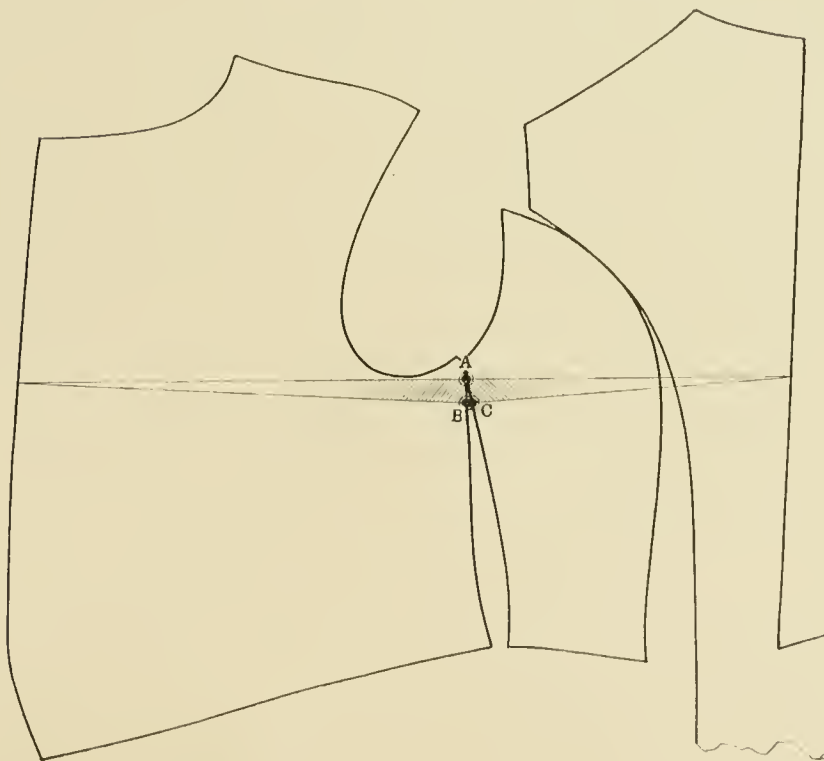

DIAGRAM 33.

## DIAGRAM 34

## FIGURE WITH A FLAT BLADE AND A FULL CHEST.

The measurements are the same as in diagram 27, with the exception that the blade measure is  $12\frac{1}{2}$  inches, which is  $\frac{1}{2}$  inch smaller than normal.

Square down and out from A.

From A to B is the scye depth plus  $\frac{1}{4}$  inch; C is natural waist length; F is halfway between A and B; G is halfway between A and F; square out from G, F, B and C.

From C to R is  $\frac{3}{4}$  inch; draw a straight line from A through R; this locates H; from H to I is  $\frac{1}{2}$  breast; I to J is  $1\frac{1}{2}$  inches; K is halfway between H and I; K to L is  $3\frac{1}{2}$  inches; square down from L; this locates M; from M to I is  $\frac{1}{2}$  waist; apply the blade measure from H to 8 which is  $12\frac{1}{2}$  inches and square up and down; this locates 9; point 5 is halfway between 9 and I; point 6 is halfway between 8 and J; draw a line from 5 through 6 up; point N is halfway between H and 8; N to O is  $1\frac{1}{4}$  inches; from A to 2 is  $\frac{1}{2}$  the distance of from 8 to L; draw a line from H to 2.

From 2 to T is  $6\frac{3}{8}$  inches; T to U is  $1\frac{1}{2}$  inches; draw a line from 2 to U; from 2 to V is  $\frac{3}{8}$  breast; square up from V to locate W; draw a line from  $\frac{1}{4}$  inch below W to P and finish the coat as usual.

## DIAGRAM 35

## FIGURE WITH A LARGE BLADE AND A FLAT CHEST.

The measurements for this coat are the same as in the previous diagram with the exception that the blade measurement is  $13\frac{1}{2}$  inches, which makes it  $\frac{1}{2}$  inch larger than normal.

Square down and out from A.

From A to B is the scye depth plus  $\frac{1}{4}$  inch; C is waist length; F is halfway between A and B; G is halfway between A and F; square out from G, F, B and C; this locates H; from H to I is  $\frac{1}{2}$  full breast; I to J is  $1\frac{1}{2}$  inches; J to 14 is  $\frac{3}{4}$  inch; K is halfway between H and I; from K to 8 is  $3\frac{1}{2}$  inches; square down from 8 to locate 9; from 9 to 4 is  $\frac{1}{2}$  waist; apply the blade measure from H to L which is  $13\frac{1}{2}$  inches and square up and down; this locates M; point 5 is halfway between M and I; point 6 is halfway between L and J; draw a line from 5 through 6 up.

From A to 2 is  $\frac{1}{2}$  the distance of 8 to L, in this case  $\frac{1}{4}$  inch; from 2 to T is  $6\frac{3}{8}$  inches; T to U is  $1\frac{1}{2}$  inches; draw a line from U to A; from 2 to V is  $\frac{3}{8}$  breast; square up from V to locate W; draw a line from  $\frac{1}{4}$  inch below W to P and shape the back; now draw a line from 2 to F and reshape the center as per broken line.

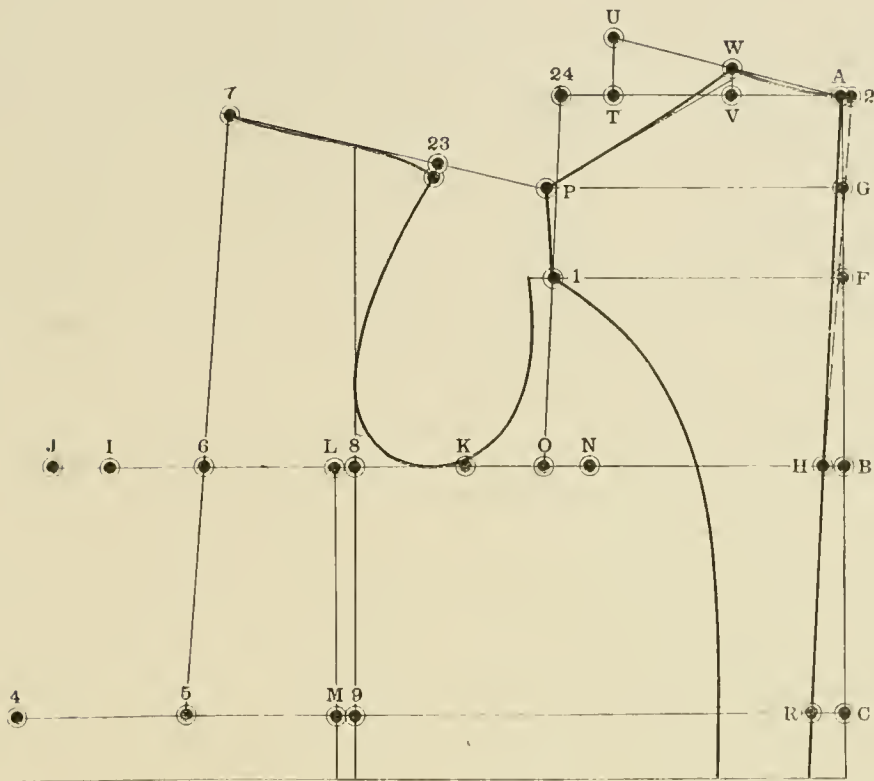

DIAGRAM 34.

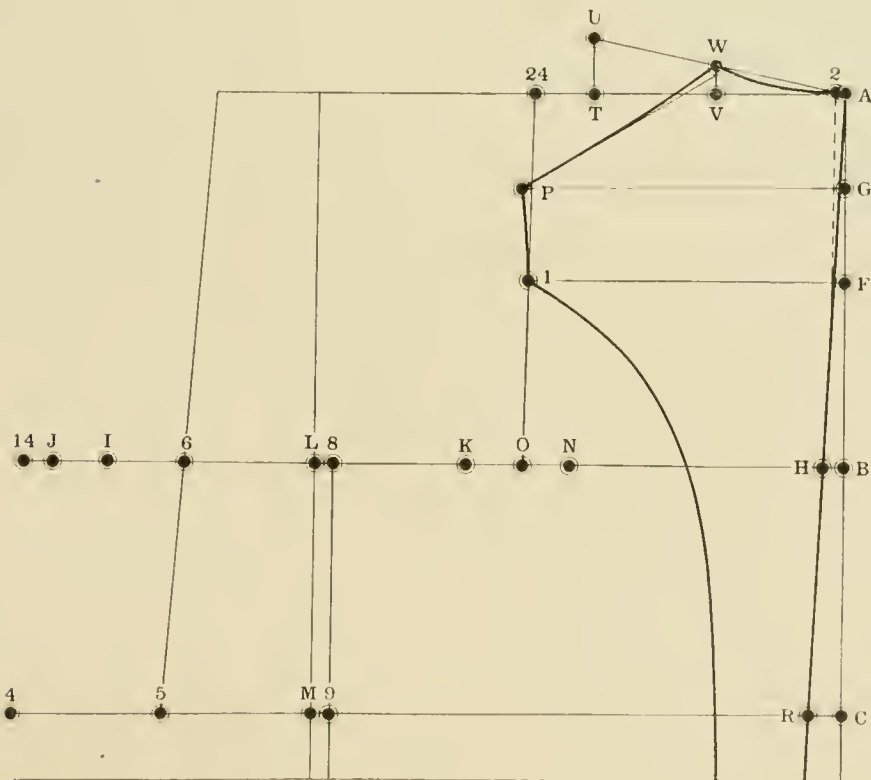

DIAGRAM 35.

## DIAGRAM 36

## THREE-BUTTON FROCK.

The measurements are as follows:

Seye depth .....	$9\frac{3}{8}$ inches	Overshoulder .....	$17\frac{5}{8}$ inches
Waist length .....	$16\frac{1}{2}$ inches	Blade .....	13 inches
Fashionable waist length .....	$18\frac{1}{4}$ inches	Breast .....	38 inches
Full length* .....	38 inches	Waist .....	36 inches
Strap .....	$12\frac{1}{2}$ inches		

This is the kind of a coat that is neither stout nor regular, and is made as follows:  
Square down and out from A.

From A to B is the seye depth plus  $\frac{1}{4}$  inch; C is waist length; C to D is fashionable waist length; E is full length; F is halfway between A and B; G is halfway between A and F; square out from G, F, B, C, D and E.

From C to R is  $\frac{1}{2}$  indentation; draw a line from A through R to Q and square down; this locates H; from H to I is  $\frac{1}{2}$  breast; I to J is  $1\frac{1}{2}$  inches; J to H is  $\frac{3}{4}$  inch; K is halfway between H and I; K to L is  $3\frac{1}{2}$  inches; square down from L to locate M; apply the blade measure from H to L which is 13 inches and square up; N is halfway between H and L; from N to O is  $1\frac{1}{4}$  inches; from A to 24 is the same distance as from H to O; draw a line from O to 24.

From A to T is  $6\frac{3}{8}$  inches; T to U is  $1\frac{1}{2}$  inches; draw a line from A to U; from A to V is  $\frac{1}{6}$  breast; square up from V to locate W; draw a line from  $\frac{1}{4}$  inch below W to P; from Q to S is  $\frac{1}{8}$  breast; square down from S and shape back; from X to Y is  $1\frac{1}{4}$  inches; from 1 to 2 is  $\frac{3}{4}$  inch; from O to K is  $\frac{1}{2}$  breast; point 20 is halfway between Y and M; draw a line from K through 20; point 3 is  $\frac{1}{2}$  inch above the waist line; shape the sidebody.

From M to 4 is  $\frac{1}{2}$  waist; square down from 4; this locates 11; from 11 to 12 is  $\frac{1}{2}$  inch less than  $\frac{1}{6}$  breast; point 5 is halfway between M and I; point 6 is halfway between L and J; draw a line from 5 through 6 up; from A to W and L to 7 is the strap measure plus  $\frac{3}{4}$  inch; draw a line from 7 to P; from 7 to 23 is  $\frac{3}{8}$  inch less than W to P; drop the shoulder  $\frac{3}{8}$  inch at 23 and shape the shoulder and armseye; square forwards from 7 by line 5-6; from 7 to 9 is  $\frac{1}{6}$  breast; draw a rounding line from 9 to 14; make the distance from 9 to 10 according to style; 7 to 8 is  $\frac{1}{8}$  breast; shape the gorge.

From 1 back to 27 in this case is  $13\frac{1}{4}$  inches; there being no fish cut out in this coat, therefore, it requires  $\frac{1}{2}$  inch less for makeup; apply the waist measure from X to R, 27 to Y and suppress the balance between Z and 21; shape the side of forepart; draw a line from 3 to 12; 11 to 15 is  $1\frac{1}{4}$  inches; 4 to 13 is the same.

## THE SKIRT.

Square down from Y; from Y to 25 is 9 inches; 25 to 26 is  $1\frac{1}{2}$  inches; draw a line from 22 through 26 down; from 22 to 19 is  $\frac{1}{4}$  inch more than from S to 17; from 12 to 18 is the same distance as 22 to 19; draw a line from 19 to 18; point 16 is  $\frac{5}{8}$  inch below point 3; shape the top of skirt, front edge and finish.



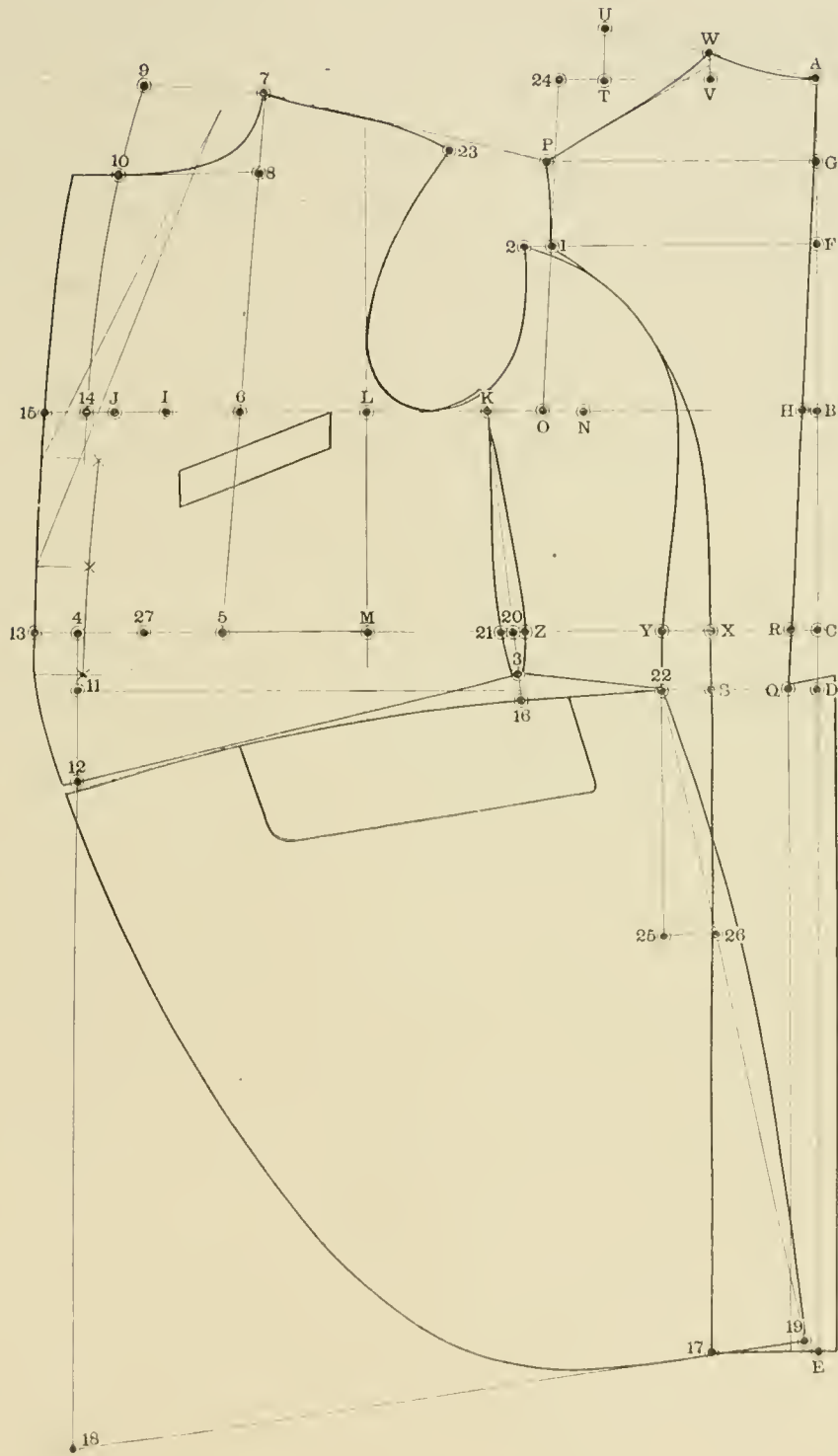

DIAGRAM 36.

## DIAGRAM 37

## THREE-BUTTON SACK.

We often hear cutters say our trade is a college trade,—young men of athletic build with large chests and small waists. The following diagrams will show how the same method of cutting will produce a coat for the athlete with a large breast and a small waist.

The measurements are as follows:

Indentation .....	2 inches	Overshoulder .....	17 $\frac{3}{4}$ inches
Scye depth .....	9 $\frac{3}{8}$ inches	Blade .....	13 inches
Waist length .....	17 inches	Breast .....	38 inches
Full length .....	30 inches	Waist .....	32 inches
Strap .....	12 $\frac{3}{4}$ inches	Seat .....	39 inches

Square down and out from A.

From A to B is the scye depth plus  $\frac{1}{4}$  inch; C is waist length, C to D is 6 inches; A to E is full length; F is halfway between A and B; G is halfway between A and F; square out from G, B, C, D and E.

From C to 2 is  $\frac{1}{2}$  the indentation, in this case 1 inch; from E to 22 is  $\frac{1}{2}$  the distance of C to 2, in this case  $\frac{1}{2}$  inch; draw a line from F to 2 and 2 to 22 and shape the center of back; this locates 1; from 1 to H is  $\frac{1}{2}$  breast; H to I is 13 $\frac{1}{4}$  inches; I to J is 3 $\frac{1}{4}$  inch; K is halfway between 1 and H; K to L is 3 $\frac{1}{2}$  inches; square down from L to locate Q; apply the blade measure from 1 to L which is 13 inches and square up.

Point M is halfway between 1 and L; from M to N is 1 $\frac{1}{4}$  inches; square up from N to locate O; from N to P is  $\frac{1}{2}$  breast; point 4 is halfway between M and N; from 22 to 7 is the same distance as from 1 to 4; draw a line from 1 to 7; from A to 8 is 6 $\frac{3}{8}$  inches; 8 to 9 is 1 $\frac{1}{2}$  inches; draw a line from A to 9; from A to 10 is  $\frac{1}{2}$  breast; square up from 10 to locate 11; draw a line from  $\frac{1}{4}$  inch below 11 to O and shape the back.

Add an extra  $\frac{1}{4}$  inch at 19; from Q to S is  $\frac{1}{2}$  waist, in this case 8 inches; point T is halfway between Q and S; point U is halfway between L and I; draw a line from T through U up; from A to 11 and L to V is the strap measure plus  $\frac{3}{4}$  inch; draw a line from V to O; from V to Z is  $\frac{3}{8}$  inch less than 11 to O; drop the shoulder  $\frac{3}{8}$  inch at Z and shape the shoulder and armseye.

Square forwards from V by line T-U; from V to W is  $\frac{1}{2}$  breast plus  $\frac{3}{4}$  inch; make the distance from W to X to suit the style; from V to Y is  $\frac{1}{8}$  breast; shape the gorge; from Q to R is  $\frac{1}{2}$  the indentation, in this case 1 inch; draw a line from R through S; from S to 13 is 1 inch; J to 12 is the same; square down from 13 by line R-S; this locates point 6 and 16; from 6 to 15 is 3 inches; S to 14 is 2 $\frac{1}{2}$  inches; apply the waist measure from 5 to 2 and 11 to 24; point 18 is halfway between 5 and 24; apply the seat measure from 19 to 3 and 15 to 20; draw a line from 18 through 20 and shape the side of forepart; this leaves the distance between 18 and 24 to be suppressed.

Cut out an under-arm fish which may be taken out a little larger than usual, and also a front fish if desired. In cutting a front fish proceed as follows: start the under-arm fish about 1 inch above the pocket; now cut your front fish, which is placed about 1 inch from the front of the pocket to strike about the center of the breast pocket; cut the pocket open from the front fish to the side fish and take out a small V on a line parallel with the under-arm fish as shown; this will take off one seam at the front fish and the V that is cut out in the pocket will take up the other seam and make the upper and lower edge of the pocket correspond.

From 18 to 21 is the same distance as from 5 to 7; 16 to 17 is  $\frac{1}{8}$  breast; shape the front edge, bottom of forepart and finish.

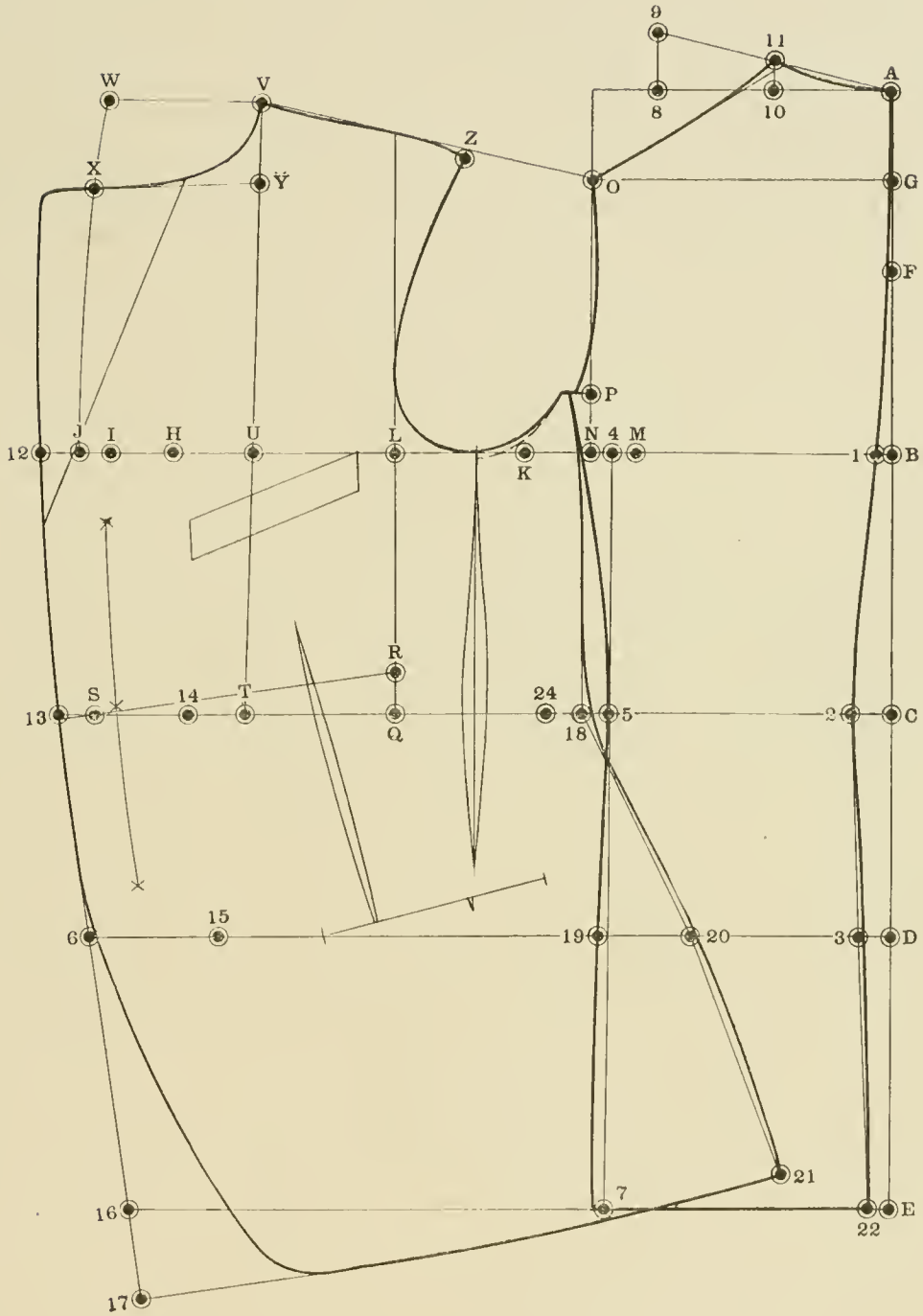

DIAGRAM 37.

## DIAGRAMS 38 AND 39

## FROCK COAT FOR A LARGE BREAST, SMALL WAIST &amp; SLIGHTLY SWAY-BACK.

This coat is cut by the same measurements as the sack coat with the exception that

Fashionable waist length is .....  $18\frac{1}{4}$  inches  
 Full length ..... 38 inches

Square down and out from A.

From A to B is the scye depth plus  $\frac{1}{4}$  inch; C is natural waist length; D is fashionable waist length; E is full length; F is halfway between A and B; G is halfway between A and F; square out from G, F, B, C, D and E.

From C to R is  $\frac{1}{2}$  the indentation, in this case 1 inch; draw a straight line from A through R to Q and square down; this locates H; from H to I is  $\frac{1}{2}$  breast; I to J is  $1\frac{1}{2}$  inches; J to H is  $\frac{3}{4}$  inch; K is halfway between H and I; K to L is  $3\frac{1}{2}$  inches; square down from L to locate M; apply the blade measure from H to L which is 13 inches and square up; N is halfway between H and L; N to O is  $1\frac{1}{4}$  inches; from A to 21 is the same distance as from H to O; draw a line from O to 21.

From A to T is  $6\frac{3}{8}$  inches; T to U is  $1\frac{1}{2}$  inches; draw a line from A to U; from A to V is  $\frac{1}{6}$  breast; square up from V to locate W; draw a line from  $\frac{1}{4}$  inch below W to P; from Q to S is  $\frac{1}{8}$  breast; square down from S and shape the back; from M to 4 is  $\frac{1}{2}$  waist; square down from 4 to locate 11; from 11 to 12 is  $\frac{1}{2}$  inch less than  $\frac{1}{6}$  breast; from 4 back to 27 is  $2\frac{1}{4}$  inches; from X to R and 27 to 29 is the waist measure net; point Y is halfway between X and 29; square down from Y; point Z is halfway between Y and M.

From O to K is  $\frac{1}{2}$  breast; 1 to 2 is  $\frac{3}{4}$  inch; point 3 is  $\frac{1}{2}$  inch above the waist line; shape the sidebody; point 5 is halfway between M and 4; point 6 is halfway between L and J; draw a line from 5 through 6 up; from A to W and L to 7 is the strap measure plus  $\frac{3}{4}$  inch; draw a line from 7 to P; from 7 to 23 is  $\frac{3}{8}$  inch less than W to P; drop the shoulder  $\frac{3}{8}$  inch at 23 and shape the shoulder and armseye.

Square forwards from 7 by line 5-6; from 7 to 9 is  $\frac{1}{6}$  breast plus  $\frac{1}{4}$  inch; draw a rounding line from 9 to 11; from 9 to 10 is the depth of the gorge desired; 7 to 8 is  $\frac{1}{8}$  breast; draw a line from 8 through 10 and shape the gorge.

From 11 to 15 is  $1\frac{1}{4}$  inches; 4 to 13 is the same; now suppress the waist between 28 and 21 the same amount as the distance is between Y and 29 and finish the upper part of the coat.

## THE SKIRT.

In this case the skirt is made as follows: from M to 19 is  $\frac{3}{4}$  inch always; from 19 to 20 is  $\frac{1}{2}$  indentation, in this case 1 inch; draw a line from 20 to Y and square down to 30; from Y to 30 is 9 inches; 30 to 31 is  $1\frac{1}{2}$  inches; draw a line from 22 through 31 down; if the indentation had been normal, the skirt would be cut in the following manner; M-Y would be the natural waist line to square from; place the square to M-Y and square down; this would produce point 25; 25 to 26 is  $1\frac{1}{2}$  inches; if you drew the line from 22 through 26 it would give you line 32 and in that case the skirt would have less spring than it has now.

From 22 to 33 is  $\frac{1}{4}$  inch more than from S to 17; 12 to 18 is the same distance as 22 to 33; draw a line from 33 to 8; point 16 is  $\frac{5}{8}$  inch below point 3; shape the front edge and skirt as shown and finish.

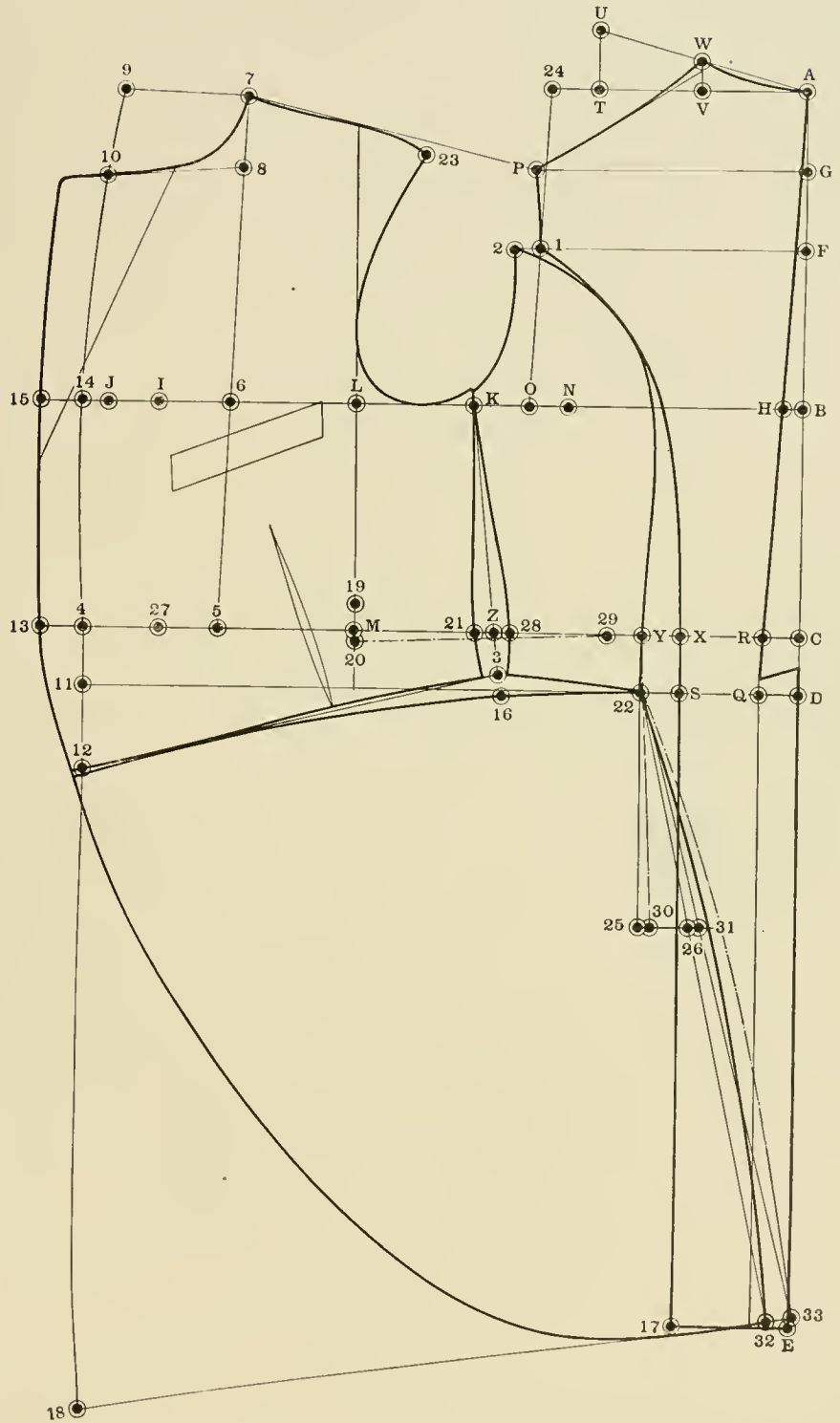

DIAGRAM 38.

DIAGRAM 39

## DIAGRAM 40

## FROCK COAT (CONTINUED)

This coat is the same as shown on diagram 39 with the exception that the indentation is 1 inch, therefore the seat is flat and the skirt is cut as follows: from M to 19 is  $\frac{3}{4}$  inch always; 19 to 20 is  $\frac{1}{2}$  indentation, in this case  $\frac{1}{2}$  inch; place the square to points 20-Y and square down; from Y to 25 is 9 inches; 25 to 26 is  $1\frac{1}{2}$  inches; finish your skirt as usual.

The normal indentation is  $1\frac{1}{2}$  inches, therefore when the indentation is normal, there is no need to go up from M to 19,  $\frac{3}{4}$  inch because the normal line is the waist line.



DIAGRAM 10.

## DIAGRAM 41

## THREE-BUTTON FROCK FOR STOUT FIGURE.

The measurements are as follows:

Indentation .....	1½ inches	Strap .....	13 inches
Scye depth .....	9½ inches	Overshoulder .....	18¼ inches
Waist length .....	16¾ inches	Blade .....	13½ inches
Fashionable waist length .....	18½ inches	Breast .....	40 inches
Full length according to style		Waist .....	40 inches

Square down and out from A.

From A to B is the scye depth plus ¼ inch; C is natural waist length; D is fashionable waist length; E is full length; F is halfway between A and B; G is halfway between A and F; square out from G, F, B, C, D and E.

From C to R is ½ indentation; draw a straight line from A through R to Q and square down; this locates H; from H to I is ½ breast; I to J is 1½ inches; J to 14 is ¾ inch; square up from 14; K is halfway between H and I; K to L is 3½ inches; square down from L to locate M; apply the blade measure from H to L which is 13½ inches and square up; N is halfway between H and L; from N to O is 1¼ inches; from A to 24 is the same distance as from H to O; draw a line from O to 24.

From A to T is 6¾ inches; T to U is 1½ inches; draw a line from A to U; from A to V is ¾ breast; square up from V to locate W; draw a line from ¼ inch below W to P; from Q to S is ⅛ breast; square down from S and shape the back.

## THE SIDEBODY

From X to Y is 1¼ inches; from 1 to 2 is ¾ inch; from O to 36 is ½ breast; point Z is halfway between Y and M; point 3 is ½ inch above the waist line; shape the side-body as shown; from M to 4 is ½ waist; square down from 4; this locates 11; from 11 to 12 is ½ inch less than ¼ breast; 12 to 34 is ¾ inch; draw a line from 3 to 34; now draw a straight line from 22 to 12; point 35 is where the two lines cross; cut out a small V at 35; hollow the waist seam slightly from 3 to 35 as shown in this diagram.

In cutting out this coat, the space between 12 and 34 is cut out and this is what produces the fulness over the stomach; point 5 is halfway between M and 4; point 6 is halfway between L and J; draw a line from 5 through 6 up; from A to W and L to 7 is the strap measure plus ¾ inch; draw a line from 7 to P; from 7 to 23 is ⅜ inch less than W to P; 23 to 38 is ⅜ inch; shape the shoulder and armseye.

Square forwards from 7 by line 5-6, also square forwards from 6 by the same line; this locates 37; from 7 to 9 is ¼ breast; 9 to 10 is the same; from 7 to 8 is ⅛ breast; draw a line from 8 through 10 and shape the gorge; from 4 back to 27 is 1¾ inches; from Z to Y, X to R and 27 to 21 is the waist measure net; shape the side of forepart; add from 37 to 15, 1¼ inches and from 4 to 13 the same and shape the front edge.

## THE SKIRT

Square down from Y; from Y to 25 is 9 inches; 25 to 26 is 1½ inches; draw a line from 22 through 26 down; from 22 to 32 is ¼ inch more than from S to 17; from 34 to 18 is the same distance as 22 to 32; draw a line from 32 to 18; point 16 is ⅝ inch below point 3; shape the skirt and finish, rounding the latter ⅝ inch at 26.

The checking off of the strap and the over shoulder measure plus 1 inch should be done in the frock coats as in all other coats.



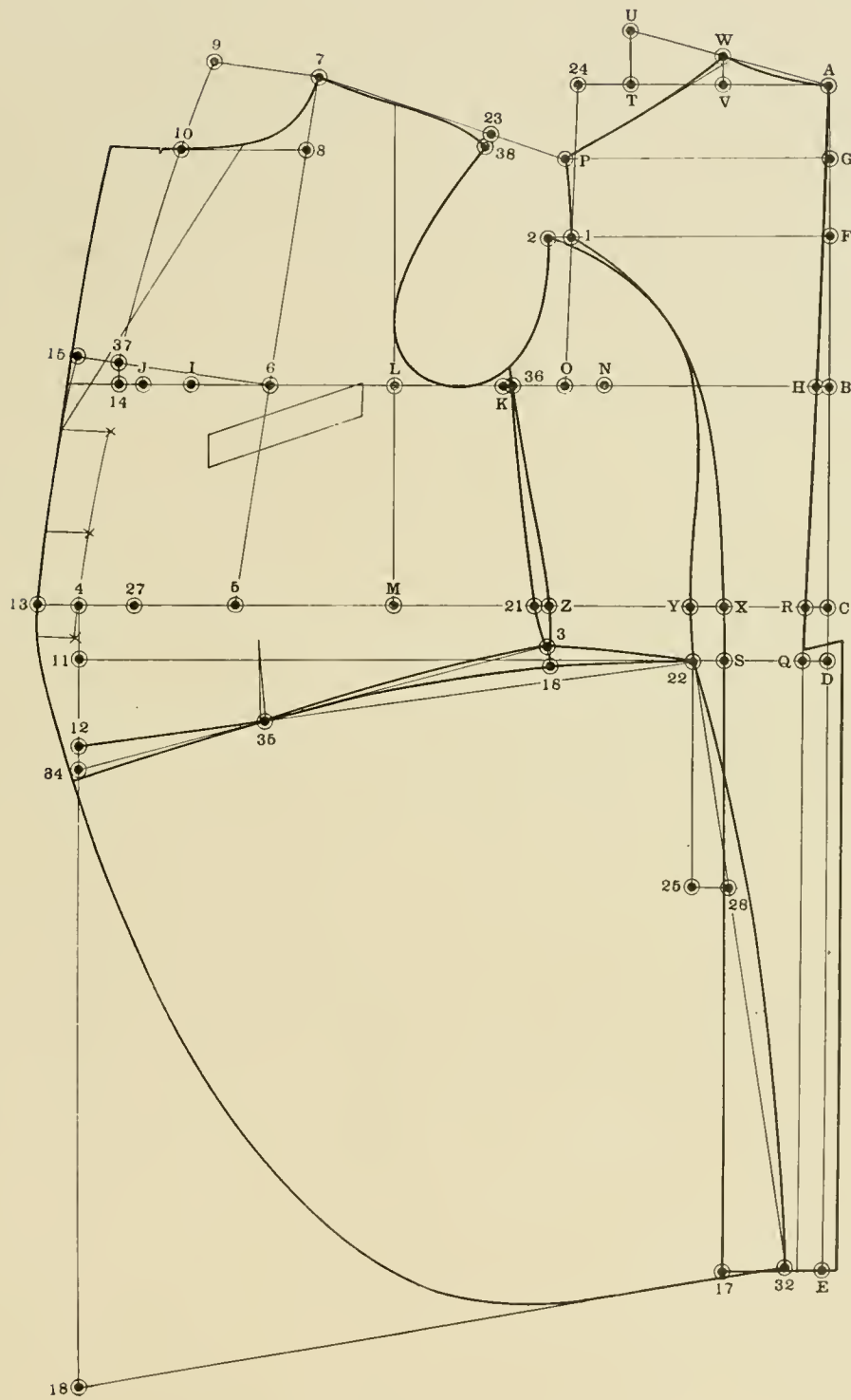

DIAGRAM 41.

## DIAGRAM 42

## THREE BUTTON FROCK FOR A CORPULENT FIGURE

The measurements are as follows:

Indentation . . . . .	1½ inches	Strap . . . . .	13½ inches
Scye depth . . . . .	9¾ inches	Overshoulder . . . . .	19 inches
Natural waist length . . . . .	17 inches	Blade . . . . .	14 inches
Fashionable waist length . . . . .	18½ inches	Breast . . . . .	12 inches
Full length, whatever the style calls for.		Waist . . . . .	15 inches

Square down and out from A.

From A to B is the scye depth plus ¼ inch; C is natural waist length; D is fashionable waist length; E is full length; F is halfway between A and B; G is halfway between A and F; square out from G, F, B, C, D and E.

From C to R is ¾ inch or ½ the indentation; draw a straight line from A through R to Q; this locates H; from H to I is ½ breast; I to J is 1½ inches; J to 14 is ¾ inch; square up from 14; K is halfway between H and I; K to L is 3½ inches; square down from L to locate M; apply the blade measure from H to L which is 14 inches and square up; N is halfway between H and L; N to O is 1¼ inches; from A to 24 is the same distance as from H to O; draw a line from O to 24.

From A to T is 6¾ inches; T to U is 1½ inches; draw a line from A to U; from A to V is ¼ breast; square up from V to locate W; draw a line from ¼ inch below W to P; from Q to S is ¼ breast; square down from S and shape the back. This being a corpulent coat, the waist suppression is made as follows: from M to 4 is ½ waist; square down from 4; this locates 11; from 11 to 12 is ½ inch less than ¼ breast; 12 to 34 is ¾ inch; from 4 back to 27 is 1¾ inches; from X to R and 27 to Y is the waist measure net; this leaves nothing to come out at Z.

Square down from Y; from 1 to 2 is ¾ inch; point Z is halfway between Y and M; from O to 36 is ½ breast; draw a line from 36 to Z; point 3 is ½ inch above the waist line; shape the sidebody with a slight hollow from 22 to 3, also draw a line from 3 to 34; now draw a straight line from 22 through 12; this locates 35; cut out a small V at 35; shape the bottom of the forepart the same as shown on diagram 41.

Point 5 is halfway between M and 1; point 6 is halfway between L and J; draw a line from 5 through 6 up; from A to W and L to 7 is the strap measure plus ¾ inch; draw a line from 7 to P; from 7 to 23 is ¾ inch less than from W to P; lower the shoulder ¾ inch at 23 and shape the shoulder and armscye.

Square forwards from 7 by line 5-6 also square forwards from 6 by the same line; this locates 37; from 7 to 9 is ¼ breast; draw a rounding line from 9 to 37; from 9 to 10 is the depth of the gorge desired; 7 to 8 is ¼ breast; draw a line from 8 through 10 and shape the gorge; from 37 to 15 is 1¼ inches; 4 to 13 is the same. The skirt is made in the same manner as shown in diagram 41 with the exception that at 34 add on about ¾ inch or the amount that the front part and sidebody overlap at 3.

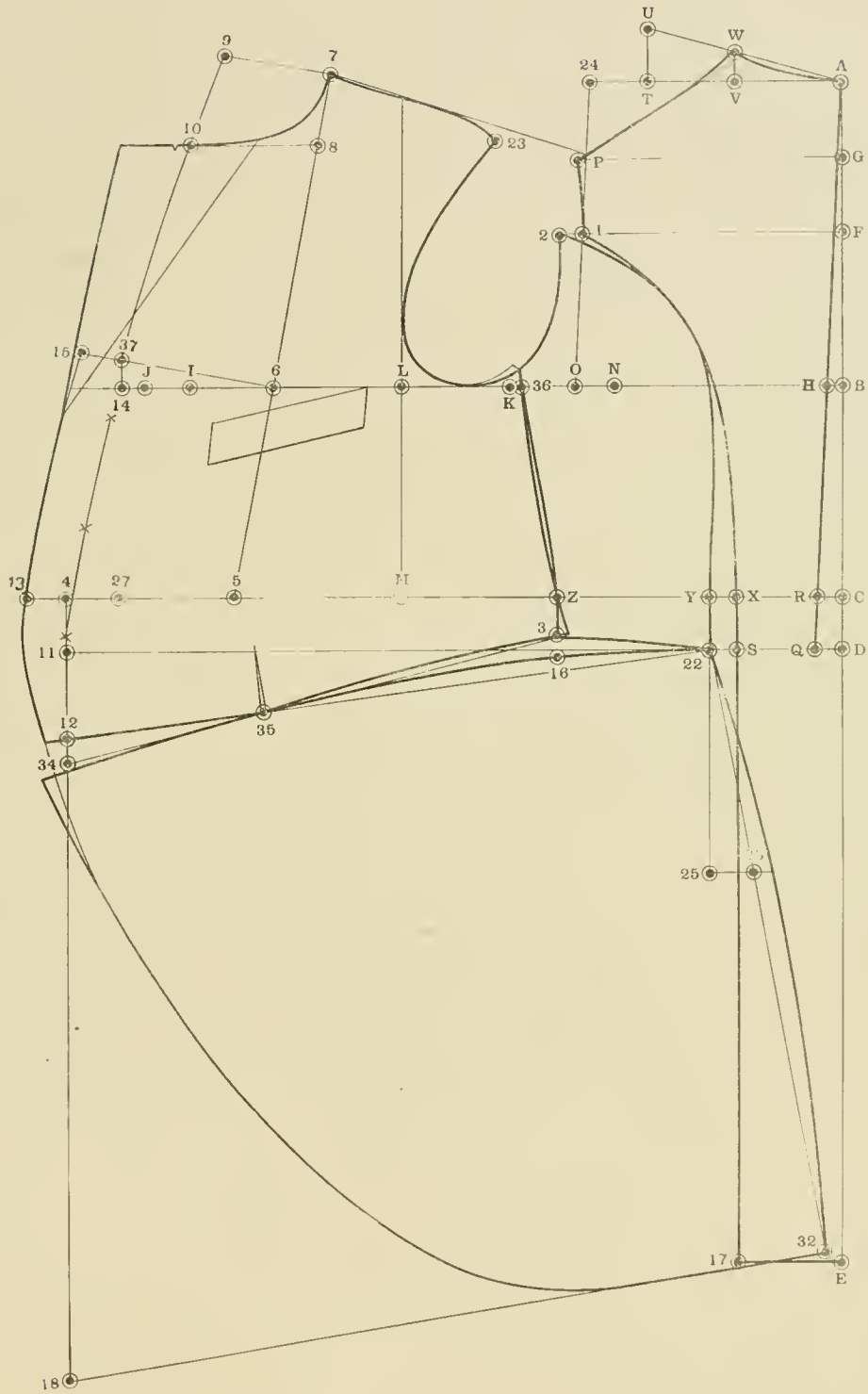

DIAGRAM 42.

## DIAGRAM 43

## ENGLISH WALKING FROCK WITH SACK FRONT

The measurements are as follows:

Indentation .....	1½ inches	Strap .....	12¾ inches
Scye depth .....	9½ inches	Overshoulder .....	18 inches
Natural waist length .....	16½ inches	Blade .....	13¼ inches
Fashionable waist length .....	18¼ inches	Breast .....	39 inches
Full length .....	37 inches	Waist .....	35½ inches

Square down and out from A.

From A to B is the scye depth plus ¼ inch; C is natural waist length; D is fashionable waist length; E is full length; F is halfway between A and B; G is halfway between A and F; square out from G. F, B, C, D and E.

From C to R is ½ indentation; draw a straight line from A through R to Q and square down; this locates H; from H to I is ½ breast; I to J is 1½ inches; J to 14 is ¾ inch; K is halfway between H and I; K to L is 3½ inches; square down from L to locate M; apply the blade measure from H to L which is 13¼ inches and square up; N is halfway between H and L; N to O is 1¼ inches; A to 24 is the same distance as from H to O; draw a line from O to 24.

From A to T is 6⅜ inches; T to U is 1½ inches; draw a line from A to U; A to V is ⅝ breast; square up from V to locate W; draw a line from ¼ inch below W to P; Q to S is ⅝ breast; square down from S and shape the back; X to Y is 1¼ inches; 1 to 2 is ¾ inch; O to K is ⅓ breast; point Z is halfway between Y and M; point 3 is ½ inch above the waist line; shape the sidebody as shown.

From M to 4 is ½ waist; square down from 4; this locates 11; from 11 to 12 is ¾ inch less than ⅝ breast; point 5 is halfway between M and 4; point 6 is halfway between L and J; draw a line from 5 through 6 up; A to W and L to 7 is the strap measure plus ¾ inch; draw a line from 7 to P; 7 to 23 is ⅜ inch less than the back shoulder width; drop the shoulder ⅜ inch at 23 and shape the shoulder and armseye; square forwards from 7 by line 5-6; 7 to 9 is ⅝ breast plus ¼ inch; draw a rounding line from 9 to 14; 9 to 10 is the depth of the gorge desired; 7 to 8 is ⅝ breast; draw a line from 8 to 10 and shape the gorge; 14 to 15 is 1¼ inches; 4 to 13 is the same; 4 back to 27 is 2¼ inches; Z to Y, X to R and 27 to 21 is the waist measure net; shape the side of forepart; draw a line from 3 to 12; this locates 16.

## THE SKIRT

Square down from Y to 25, 9 inches; 25 to 26 is 1½ inches; draw a line from 22 through 26 down; 22 to 19 is ¼ inch more than from S to 17; 12 to 18 is the same distance as S to 17; shape the skirt from 22 to 16; cut out a fish at 16; leave the front and skirt whole and finish.

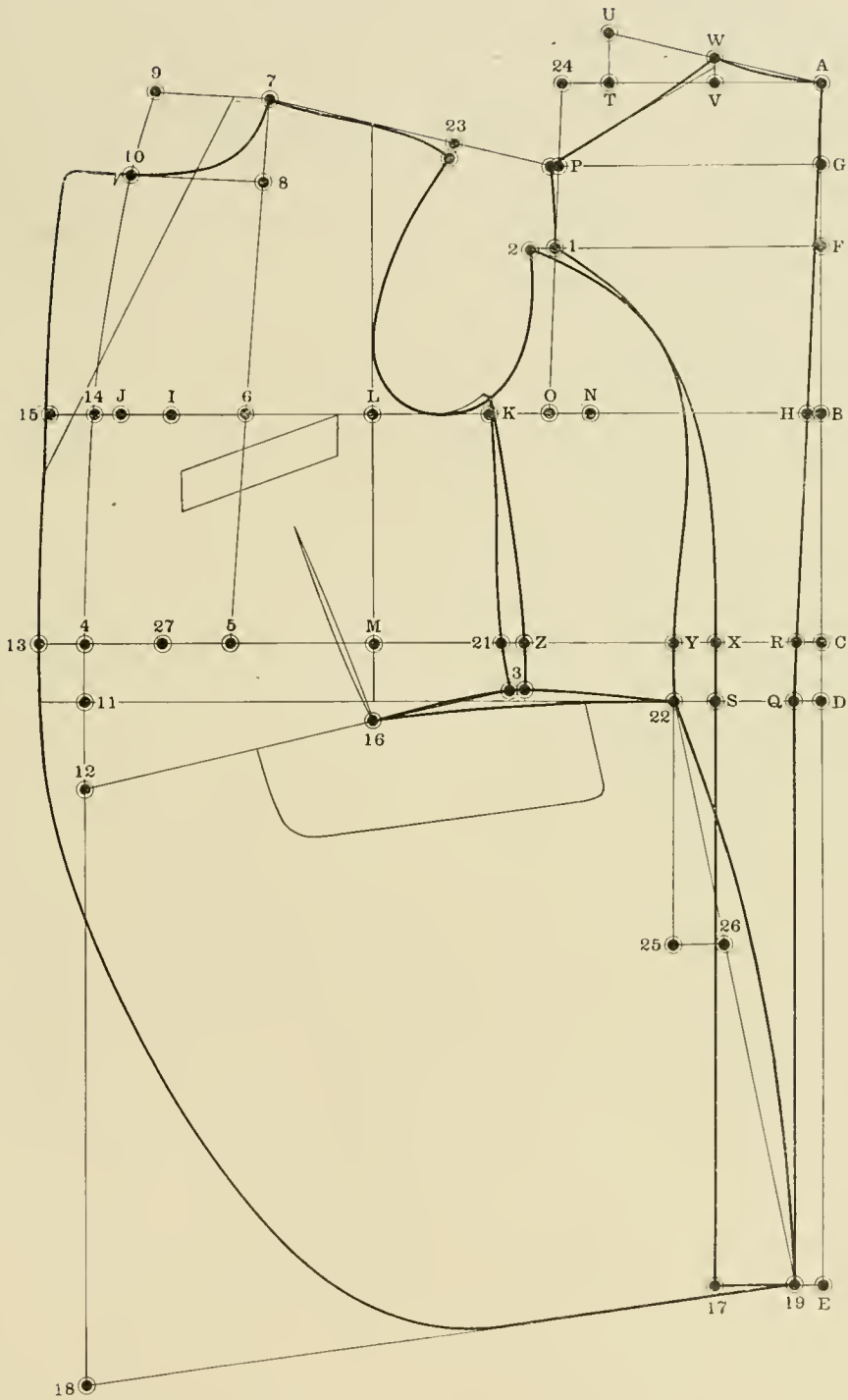

DIAGRAM 43.

## DIAGRAM 44

## SINGLE-BREADED STRAIGHT-FRONT FROCK

The measurements are as follows:—

Indentation .....	1½ inches	Strap .....	13 inches
Scye depth .....	9⅝ inches	Overshoulder ....	18¼ inches
Waist length .....	17 inches	Blade .....	13½ inches
Fashionable waist length .....	18½ inches	Breast .....	40 inches
Full length, whatever is desired.		Waist .....	37 inches

Square down and out from A.

From A to B is the scye depth plus ¼ inch; C is natural waist length; D is fashionable waist length; E is full length; F is halfway between A and B; G is halfway between A and F; square out from G, F, B, C, D and E.

From C to R is ½ indentation; draw a line from A through R to Q and square down; from H to I is ½ breast; I to J is 1½ inches; J to 14 is ¾ inch; K is halfway between H and I; K to L is 3½ inches; square down from L to locate M; apply the blade measure from H to L which is 13½ inches and square up; N is halfway between H and L; N to O is 1¼ inches; from A to 24 is the same distance as from H to O; draw a line from O to 24.

From A to T is 6⅜ inches; T to U is 1½ inches; draw a line from A to U; A to V is ⅝ breast; square up from V to locate W; draw a line from ¼ inch below W to P; Q to S is ⅝ breast; square down from S and shape the back; X to Y is 1¼ inches; square down from Y; 1 to 2 is ¾ inch; O to K is ½ breast; point Z is halfway between Y and M; point 3 is ½ inch above the waist line; shape the sidebody.

From M to 4 is ½ waist; square down from 4; this locates 11; from 11 to 12 is ½ inch less than ⅝ breast; point 5 is halfway between M and 4; point 6 is halfway between L and J; draw a line from 5 through 6 up; from A to W and L to 7 is the strap measure plus ¾ inch; draw a line from 7 to P; 7 to 23 is ⅜ inch less than the back shoulder width; drop the shoulder ⅜ inch at 23 and shape the shoulder and armseye; square forwards from 7 by line 5-6; 7 to 9 is ⅝ breast plus ½ inch; draw a rounding line from 9 to 14; from 9 to 10 is ⅝ breast; 7 to 8 is ⅝ breast; draw a line from 8 to 10 and shape the gorge; 11 to 15 is 1¼ inches; 4 to 13 is the same; place the straight edge to line 4-12 and make a mark at 29.

Sweep from 12 forwards and backwards pivoting at 29; shape the bottom of forepart from 3 hollowing it slightly into the sweep at 12; from 4 back to 27 is 2¼ inches; Z to Y, X to R and 27 to 21 is the waist measure net; shape the side of forepart.

## THE SKIRT

If a close-fitting skirt is desired, it should be made the same as in the cutaway frock; the skirt shown here is a slightly draped skirt and is made as follows; draw a straight line from 20 into the sweep at 12; square down from 20 by that line; from 20 to 25 is 9 inches; 25 to 26 is 1½ inches; draw a line from 20 through 26 down.

From 20 to 18 is ¼ inch more than from S to 17; 12 to 28 is the same distance as 20 to 18; square down from the front edge by the waist line; shape the bottom of skirt and round the side ⅝ inch at 26.

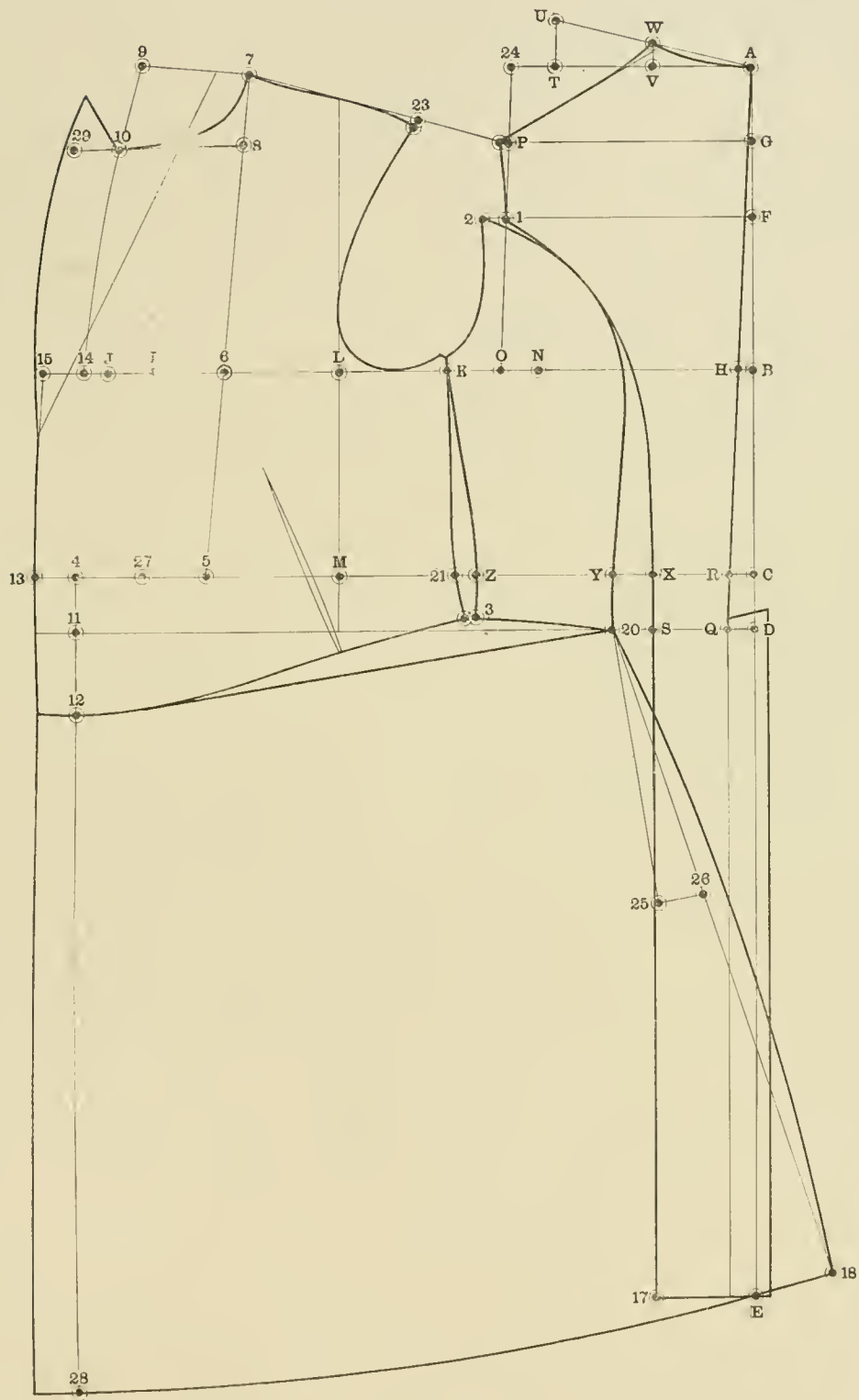

DIAGRAM 44

## DIAGRAM 45

## SINGLE-BREASTED STRAIGHT-FRONT FROCK FOR A STOUT FIGURE

The measurements are as follows:

Indentation .....	1½ inches	Strap .....	13½ inches
Scye depth .....	9¾ inches	Overshoulder .....	19 inches
Natural waist length .....	17 inches	Blade .....	14 inches
Fashionable waist length .....	18½ inches	Breast .....	42 inches
Full length according to style.		Waist .....	42 inches

Square down and out from A.

From A to B is the scye depth plus ¼ inch; C is natural waist length; D is fashionable waist length; E is full length; F is halfway between A and B; G is halfway between A and F; square out from G, F, B, C, D and E.

From C to R is ½ indentation; draw a line from A through R to Q and square down; from H to I is ½ breast; I to J is 1½ inches; J to 14 is ¾ inch; square up from 14; K is halfway between H and I; K to L is 3½ inches; square down from L to locate M; apply the blade measure from H to L which is 14 inches and square up; N is halfway between H and L; N to O is 1¼ inches; from A to 24 is the same distance as from H to O; draw a line from O to 24.

From A to T is 6¾ inches; T to U is 1½ inches; draw a line from A to U; A to V is ½ breast; square up from V to locate W; draw a line from ¼ inch below W to P; Q to S is ⅛ breast; square down from S and shape the back; from X to Y is 1¼ inches; square down from Y; from 1 to 2 is ¾ inch; O to Z is ⅛ breast; point 22 is halfway between Y and M; point 3 is ½ inch above the waist line; shape the sidebody.

From M to 4 is ½ waist; square down from 4; this locates 11; from 11 to 12 is ½ inch less than ⅛ breast; 12 to 15 is ¾ inch; point 5 is halfway between M and 4; point 6 is halfway between L and J; draw a line from 5 through 6 up; from A to W and L to 7 is the strap measure plus ¾ inch; draw a line from 7 to P; from 7 to 23 is ⅜ inch less than the back shoulder width; drop the shoulder ⅜ inch at 23 and shape the shoulder and armseye.

Square forwards from 7 by line 5-6, also square forwards from 6 by the same line; this locates 32; from 6 to 9 is ⅛ breast; draw a rounding line from 9 to 32; from 9 to 10 is ⅛ breast; 7 to 8 is ⅛ breast; draw a line from 8 through 10 and shape the gorge; 32 to 19 is 1¼ inches; 4 to 31 is the same; shape the front edge from 19 through 31; from 4 back to 27 is 1¾ inches; 22 to Y, X to R and 27 to 21 is the waist measure net; shape the side of forepart.

Now draw a line from 3 to 15 also draw a straight line from 20 to 12; point 16 is where the two lines cross; cut out a small V at 16; place the straight edge to points 12-4 and make a mark at 29; from 12 back to 30 is 2½ inches; sweep from 30 forwards to 13 pivoting at 29; shape the bottom of forepart hollowing the line slightly between 3-16.

## THE SKIRT

Place the square to line 20-16 and square down to 25; 20 to 25 is 9 inches; 25 to 26 is 1½ inches; draw a line from 20 through 26 down; from 20 to 18 is ¼ inch more than from S to 17; from 12 to 28 is the same distance as 20 to 18; square down from 13 by the waist line; shape the bottom of skirt and add ⅝ inch rounding at 26. In cutting out this skirt, there is nothing taken out between 12 and 15; the skirt is cut straight through from 20 to 16, 30 and 12 to 13.



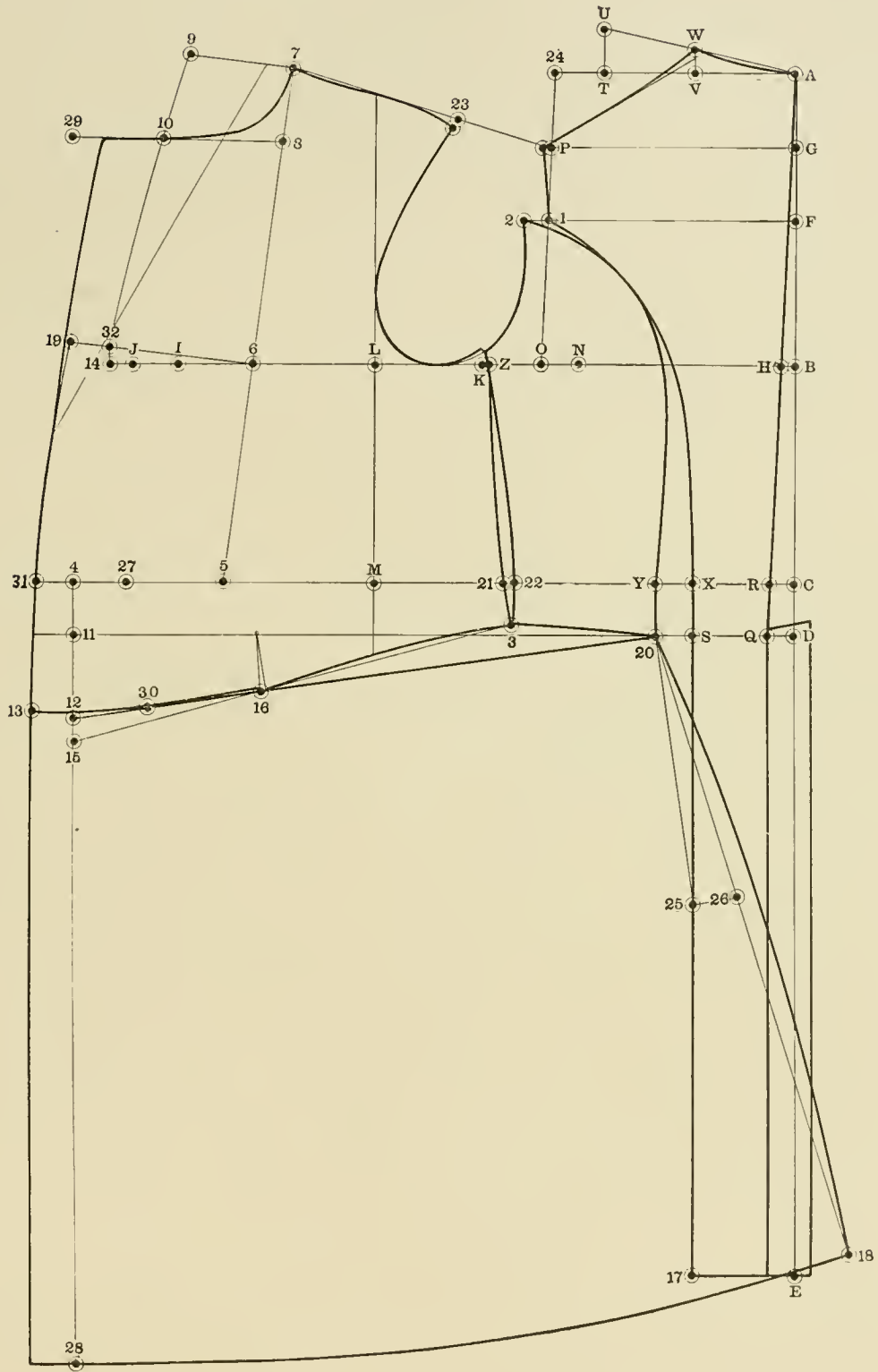

DIAGRAM 45

## DIAGRAM 46

## CLERGYMAN'S STRAIGHT-FRONT FROCK

The measurements are as follows:

Indentation . . . . .	1½ inches	Strap . . . . .	12¾ inches
Scye depth . . . . .	9½ inches	Overshoulder . . . . .	18 inches
Natural waist length . . . . .	16¾ inches	Blade . . . . .	13¼ inches
Fashionable waist length . . . . .	18½ inches	Breast . . . . .	39 inches
Full length, 40 inches or according to style		Waist . . . . .	35½ inches

Square down and out from A.

From A to B is the scye depth plus ¼ inch; C is natural waist length; D is fashionable waist length; E is full length; F is halfway between A and B; G is halfway between A and F; square out from G, F, B, C, D and E.

From C to R is ½ indentation; draw a straight line from A through R to Q and square down; from H to I is ½ breast; I to J is 1½ inches; J to 14 is ¾ inch; K is halfway between H and I; K to L is 3½ inches; square down from L to locate M; apply the blade measure from H to L which is 13¼ inches and square up; N is halfway between H and L; N to O is 1¼ inches; A to 24 is the same distance as H to O; draw a line from O to 24.

From A to T is 6⅜ inches; T to U is 1½ inches; draw a line from A to U; A to V is ⅝ breast; square up from V to locate W; draw a line from ¼ inch below W to P; Q to S is ⅝ breast; square down from S and shape the back; from X to Y is 1¼ inches; square down from Y; from 1 to 2 is ¾ inch; O to K is ½ breast; point 22 is halfway between Y and M; 34 is ½ inch above the waist line; shape the side body.

From M to 36 is ½ waist; square down from 36; this locates 11; 11 to 12 is ½ inch less than ⅝ breast; point 5 is halfway between M and 36; point 6 is halfway between L and J; draw a line from 5 through 6 up; from A to W and L to 7 is the strap measure plus ¾ inch; draw a line from 7 to P; from 7 to 23 is ⅜ inch less than the back shoulder width; shape the shoulder and armscye; square forwards from 7 by line 5-6; from 7 to 9 is ⅝ of the neck size plus ¾ inch; draw a line from 9 through 14 and 36

From 9 to 10 is ⅝ breast; 7 to 8 is ⅝ breast; draw a line from 8 to 10 and shape the gorge; now add for the left front from 10 to 30, ½ inch; 14 to 32 and 36 to 35 the same; now add to the right front from 30 to 29, 1¼ inches; 32 to 19 and 35 to 31 the same; shape the front edge; from 36 back to 27 is 2¼ inches; from 22 to Y, X to R and 27 to 21 is the waist measure net; shape the side and bottom of forepart.

## THE SKIRT

If a close-fitting skirt is desired, proceed as follows: from Y to 25 is 9 inches; 25 to 26 is 1½ inches; draw a line from 20 through 26 down; 20 to 18 is ¼ inch more than from S to 17; 12 to 28 is the same distance as 20 to 18; point 3 is ⅝ inch below 34; shape the skirt and finish, rounding it ⅝ inch at 26.

This coat may also be used for a Knights Templar coat. If a slightly flaring skirt is desired, the skirt may be made as shown on diagram 44.

## THE COLLAR

The standing collar is made as follows: draw a line from 10 through 7; from 10 to 16 is ½ the shirt collar size plus 1 inch, *i. e.*, if the collar size is 15¼ inches, ½ of which would be 7⅝, the distance from 10 to 16 would be 8⅝. Shape the collar from 16 into the gorge and square up from 16 to 15 by that line; from 16 to 15 is the height of the collar desired plus two seams; shape the collar as shown.

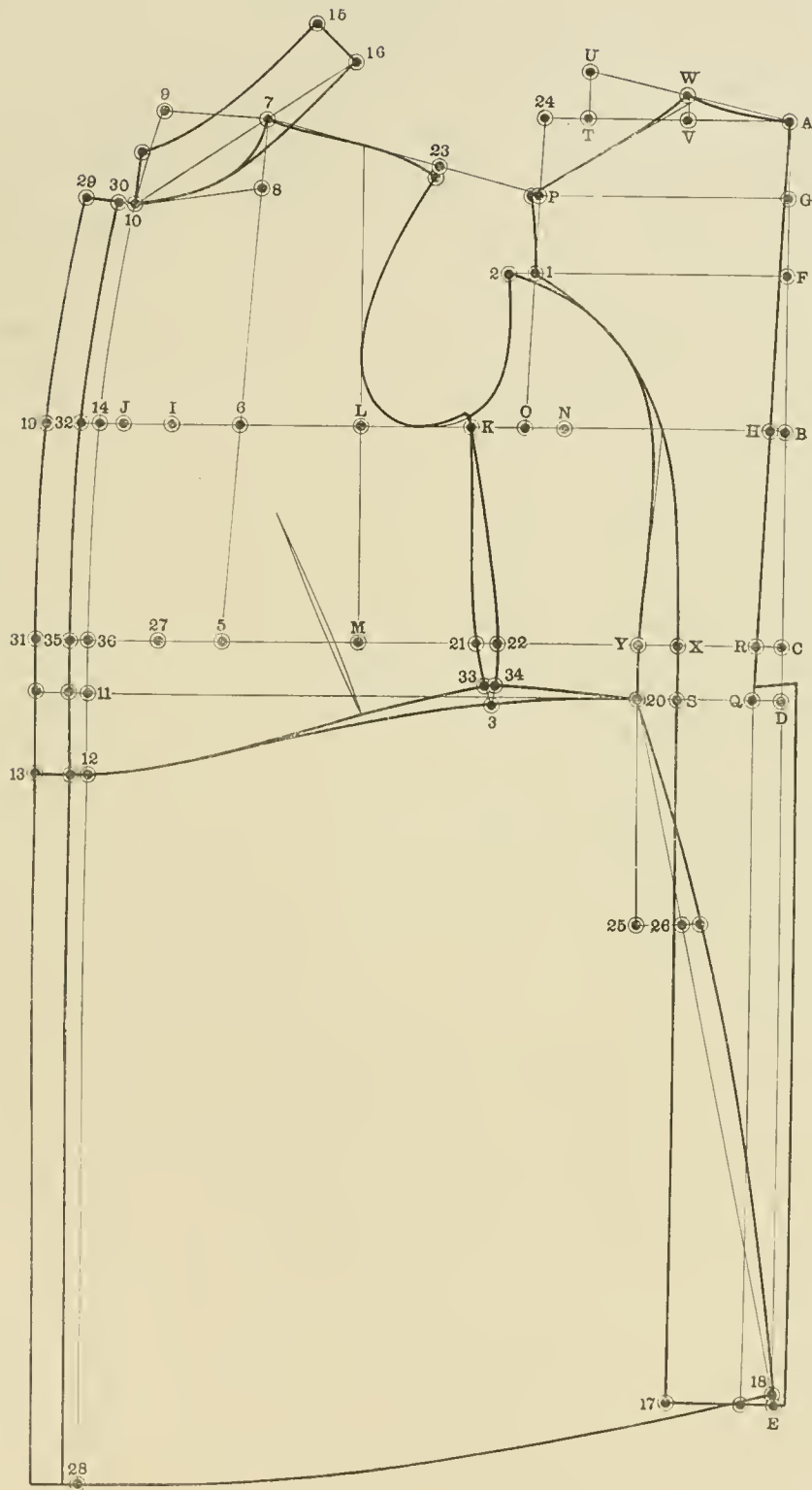

DIAGRAM 16

## DIAGRAM 47

## CASSOCK

The measurements are as follows:

Scye depth .....	$9\frac{3}{8}$ inches	Strap .....	$12\frac{1}{2}$ inches
Natural waist length .....	17 inches	Overshoulder .....	$17\frac{5}{8}$ inches
Fashionable waist length .....	$18\frac{1}{2}$ inches	Blade .....	13 inches
Full length .....	56 inches	Breast .....	38 inches
(These coats are supposed to reach down to the feet).		Waist .....	$34\frac{1}{2}$ inches

Square down and out from A.

From A to B is the scye depth plus  $\frac{1}{4}$  inch; C is natural waist length; D is fashionable waist length; E is full length; F is halfway between A and B; G is halfway between A and F; square out from G, F, B, C, D and E.

From C to R is  $\frac{3}{4}$  inch; draw a straight line from A through R to Q and from Q to E; from H to I is  $\frac{1}{2}$  breast; I to J is  $1\frac{1}{2}$  inches; J to 14 is  $\frac{3}{4}$  inch; K is halfway between H and I; K to L is  $3\frac{1}{2}$  inches; square down from L to locate M; apply the blade measure from H to L which is 13 inches and square up; N is halfway between H and L; N to O is  $1\frac{1}{4}$  inches; A to 24 is the same distance as from H to O; draw a line from O to 24.

From A to T is  $6\frac{3}{8}$  inches; T to U is  $1\frac{1}{2}$  inches; draw a line from A to U; A to V is  $\frac{1}{2}$  breast; square up from V to locate W; draw a line from  $\frac{1}{4}$  inch below W to P; from Q to S is  $3\frac{1}{4}$  inches; place the straight edge to points A-S and draw a line through to 17; shape the back; from X to Y is  $1\frac{1}{4}$  inches; square down from Y; from 1 to 2 is  $\frac{3}{4}$  inch; point Z is halfway between Y and M; point 3 is  $\frac{1}{4}$  inch above the waistline; shape the side-body.

From M to 4 is  $\frac{1}{2}$  waist; square down from 4; this locates 11; from 11 to 12 is  $\frac{3}{4}$  inch less than  $\frac{1}{2}$  breast; draw a straight line from 12 through 3; point 5 is halfway between M and 4; point 6 is halfway between L and J; draw a line from 5 through 6 up; from A to W and L to 7 is the strap measure plus  $\frac{3}{4}$  inch; draw a line from 7 to P; 7 to 23 is  $\frac{3}{8}$  inch less than the back shoulder width; drop the shoulder  $\frac{3}{8}$  inch at 23 and shape the shoulder and armseye.

Square forwards from 7 by line 5-6; from 7 to 9 is  $\frac{1}{2}$  of the collar size worn plus  $\frac{3}{4}$  inch; draw a rounding line from 9 to 14; from 9 to 10 is  $\frac{1}{2}$  breast; 7 to 8 is  $\frac{1}{8}$  breast; draw a line from 8 to 10 and shape the gorge; now add for the left front from 10 to 29,  $\frac{1}{2}$  inch; 14 to 15 and 4 to 13 the same; for the right front add from 29 to 30,  $1\frac{1}{2}$  inches and from 13 to 36 the same; square down from 13 and 36 by the waistline.

From 4 to 27 is 2 inches; from Z to Y, X to R and 27 to 21 is the waist measure net; shape the side of forepart, cutting out a small V in what will be the skirt as shown; 22 is about  $1\frac{1}{4}$  inches below 3; now place the square to line Y-12 and square down to 25; from Y to 25 is 9 inches; 25 to 26 is  $1\frac{1}{2}$  inches; draw a line from Y through 26 down; Y to 18 is  $\frac{1}{4}$  inch more than from S to 17; 12 to 28 is the same distance as 19 to 18; shape the bottom.

Now add on to the back as from Q to 23 and E to 34,  $4\frac{1}{2}$  to 5 inches; also add from S to 31 and from 17 to 32 the same amount as has been added from Q to 33; add from Y to 16 the same amount as has been added from S to 13, all the way down the same. These additions are to be made up into three inverted plaits, one in the center and one on each side.

## THE COLLAR

Draw a straight line from 10 through 7; the length of the collar should be  $1\frac{1}{2}$  sizes larger than the shirt collar; shape the collar as usual.

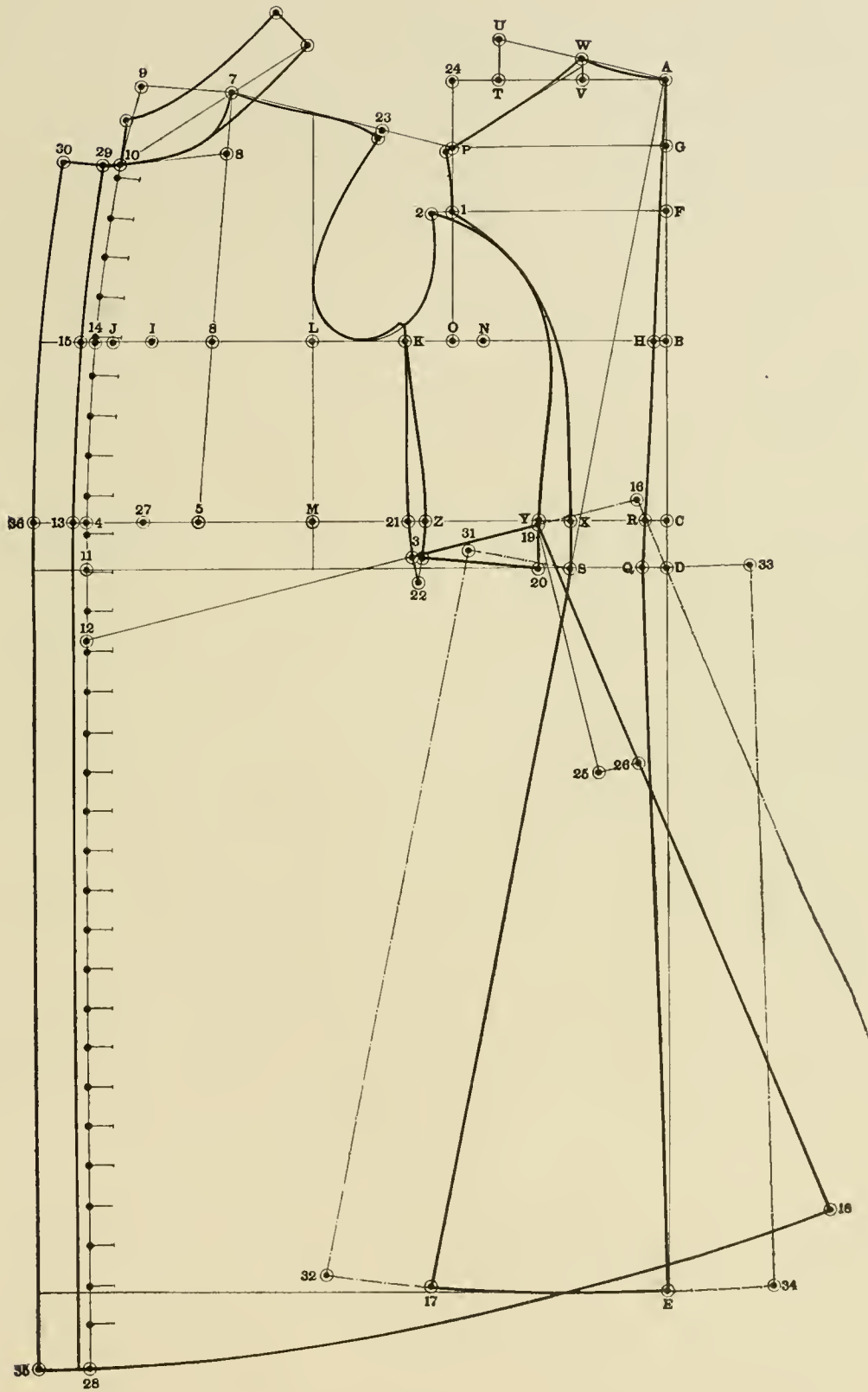

DIAGRAM 47

## DIAGRAM 48

## CLERGYMAN'S STRAIGHT-FRONT SACK

This coat is to be easy and not too shapely.

The measurements are as follows:

Scye depth .....	9 inches	Blade .....	12½ inches
Waist length .....	16½ inches	Breast .....	38 inches
Full length .....	33 inches	Waist .....	34½ inches
Strap .....	12 inches	Seat .....	40½ inches
Overshoulder .....	17 inches		

Square down and out from A.

From A to B is the scye depth plus ¼ inch; C is waist length; C to D is 6 inches; A to E is full length; F is halfway between A and B; G is halfway between A and F; square out from G, B, C, D and E.

From C to 2 is ½ indentation; square down from 2; shape the center back from F to 2; from 1 to H is ½ breast; H to I is 1¾ inches; I to J is ¾ inch; K is halfway between 1 and H; K to L is 3½ inches; square down from L to locate Q; apply the blade measure from 1 to L which is 12½ inches and square up; M is halfway between 1 and L; M to N is 1¼ inches; square up from N; N back to 4 is ¼ inch; 22 to 7 is the same distance as 1 to 4; draw a line from 4 to 7; N to P is ½ breast; A to 8 is 6⅜ inches; 8 to 9 is 1½ inches; draw a line from A to 9.

From A to 10 is ½ breast; square up from 10 to locate 11; draw a line from ¼ inch below 11 to O and shape the back; Q to S is ½ waist; point T is halfway between Q and S; point U is halfway between L and I; draw a line from T through U up; A to 11 and L to V is the strap measure plus ¾ inch; draw a line from V to O; V to Z is ⅜ inch less than the back shoulder width; drop the shoulder ⅜ inch at Z and shape the shoulder and armscye.

Square forwards from V by line T-U; V to W is ⅓ of the collar worn plus ¾ inch; draw a rounding line from W to J; W to X is ½ breast; V to Y is ⅛ breast; draw a line from Y to X and shape the gorge; X to 26 on the left front is ½ inch; J to 12 and S to 13 are the same; from Q to R is ¾ inch, ½ the indentation; place the square to point R-S and square down, also square down from 13.

From 6 back to 16 is 2½ inches; from 14 to 3 and 15 to 20 is the seat measure; 20 back to 19 is 2 inches; square up from 19 to locate 18; draw a line from 18 through 20 down and shape the side of forepart; from 18 to 21 is the same distance as 5 to 7; 31 to 32 is ⅛ breast; shape the bottom of forepart; now add to the right front from 26 to 27, 1½ inches; 12 to 28, 13 to 29 and 32 to 17 are all the same.

## THE COLLAR

Draw a line from X through Y to 23; from X to 23 is two sizes more than the size collar worn, *i. e.*, if the size collar worn is 15 inches, one-half of which would be 7½ inches, this would make the distance from X to 23, 8½ inches; shape the collar from 23 into the gorge line; square up from 23 to 24 by that line; 23 to 24 is the height of the collar desired plus two seams and from 26 to 25 is the same; shape the collar and finish.

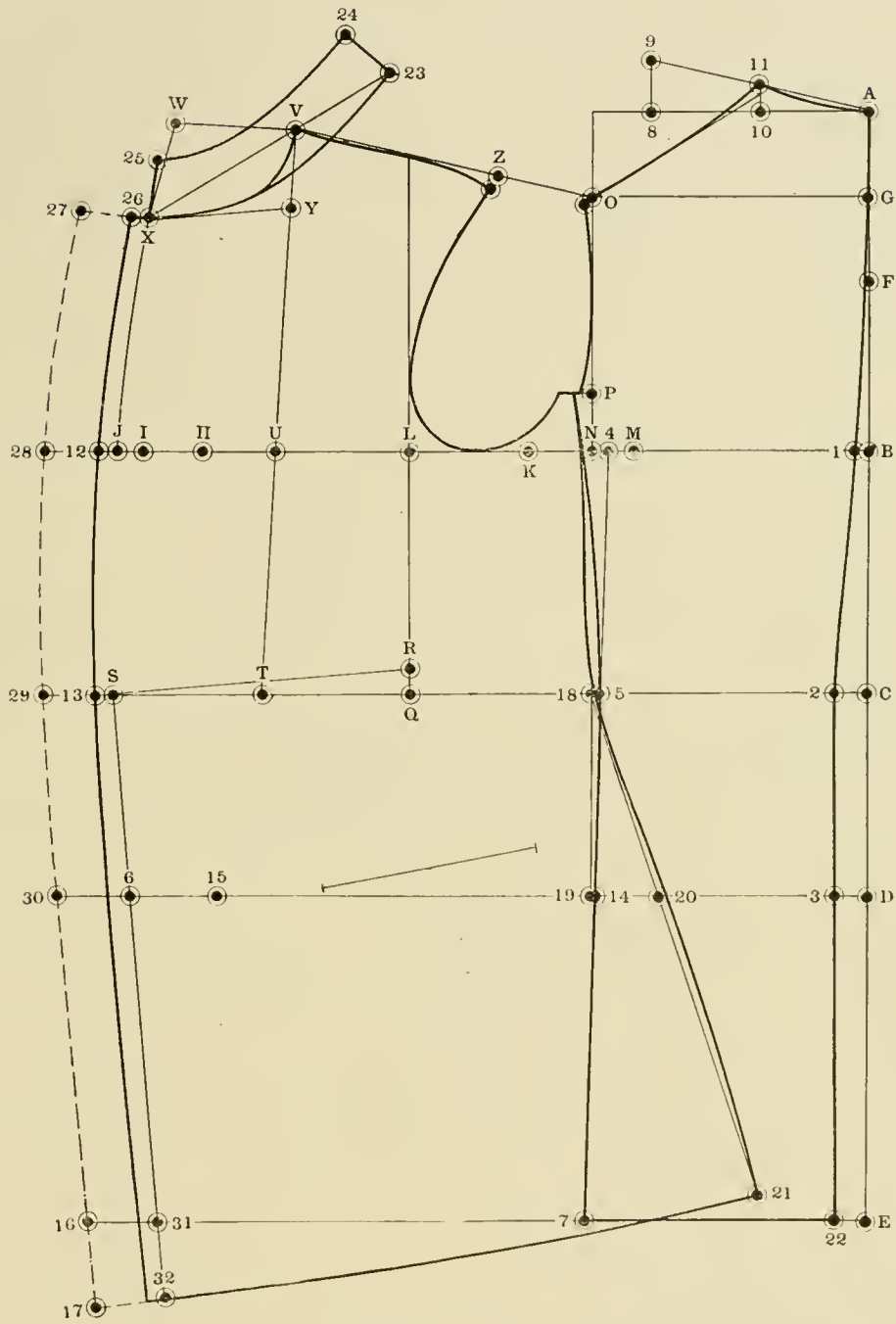

DIAGRAM 18

## DIAGRAM 49

## DOUBLE-BREASTED FROCK

The measurements are as follows:

Indentation .....	1½ inches	Strap .....	12¾ inches
Scye depth .....	9½ inches	Overshoulder .....	18 inches
Natural waist length .....	16½ inches	Blade .....	13¼ inches
Fashionable waist length .....	18¼ inches	Breast .....	39 inches
Full length, whatever style calls for		Waist .....	35½ inches

Square down and out from A.

From A to B is the scye depth plus ¼ inch; C is natural waist length; D is fashionable waist length; E is full length; F is halfway between A and B; G is halfway between A and F; square out from G, F, B, C, D and E.

From C to R is ½ indentation; draw a line from A through R to Q and square down; this locates H; H to I is ½ breast; I to J is 1½ inches; J to K is 1 inch; K is halfway between H and I; K to L is 3½ inches; square down from L to locate M; apply the blade measure from H to L which is 13¼ inches and square up; N is halfway between H and L; N to O is 1¼ inches; A to P is the same distance as H to O; draw a line from O to P; A to T is 6¾ inches; T to U is 1½ inches; draw a line from A to U; A to V is ½ breast; square up from V to locate W; draw a line from ¼ inch below W to P; from Q to S is ½ breast; square down from S and shape the back.

## THE SIDEBODY

From X to Y is 1¼ inches; square down from Y; from 1 to 2 is ¾ inch; O to K is ½ breast; 22 is halfway between Y and M; point 3 is ½ inch above the waistline; shape the sidebody.

## THE FOREPART

From M to 4 is ½ waist; square down from 4; this locates 11; from 11 to 12 is ½ inch less than ½ breast; point 5 is halfway between M and 4; point 6 is halfway between L and J; draw a line from 5 through 6 up; from A to W and L to 7 is the strap measure plus ¾ inch; draw a line from 7 to P; from 7 to 23 is ⅜ inch less than W to P; shape the shoulder and armscye.

Square forwards from 7 by line 5-6; 7 to 9 is ½ breast plus ¾ inch; add ¼ inch for seam at 4 and shape the front edge from 9 through 11 down; from 9 to 10 is ½ breast; 7 to 8 is ⅜ breast; draw a line from 8 to 10 and shape the gorge; 4 back to 27 is 2¼ inches; 22 to Y, X to R and 25 to 24 is the waist measure net; shape the side of forepart.

## THE REVER

Draw a straight line close to the front edge as at 12-4 up; sweep from 10 to 29 pivoting at 12; sweep from 12 forwards and backwards pivoting at 29; make the width of the rever according to the style desired.

## THE SKIRT

Draw a straight line from 12 to 20 and if a slightly flared skirt is desired, square down from 20. If more flare is desired, proceed as follows: go up from 20 to 30, ¾ inch more or less according to the amount of drapery desired; draw a line from 16 to 30 and square down by that line to 25; from 30 to 25 is 9 inches; 25 to 26 is 1½ inches; draw a line from 30 through 26 down; from 30 to 18 is ¼ inch more than from S to 17; from 12 to 28 is the same distance as 30 to 18; square down from 13 by the waist line; finish the skirt as shown, rounding it ⅝ inch at 26.



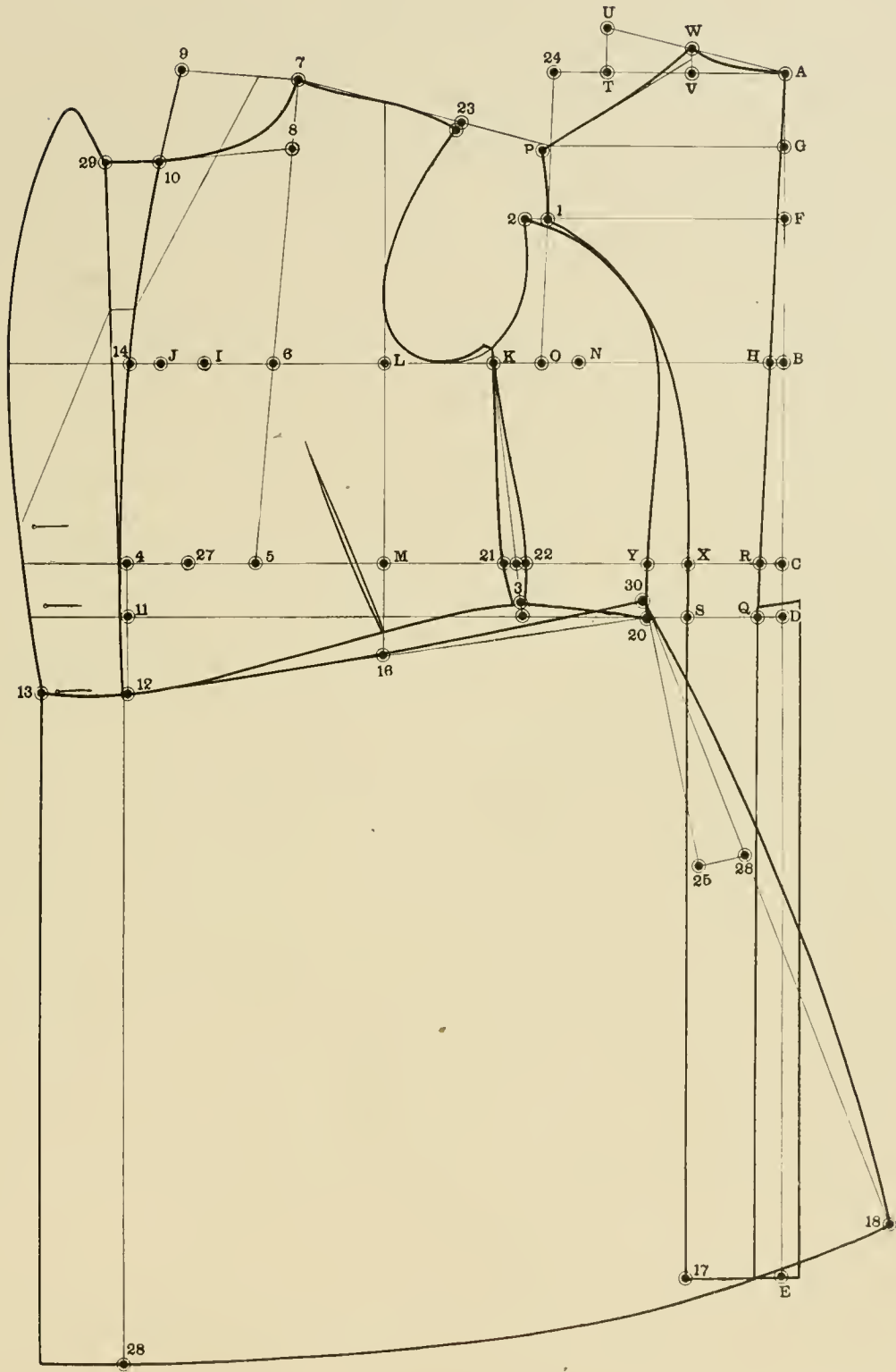

DIAGRAM 49

## DIAGRAM 50

## DOUBLE-BREADED FROCK FOR A STOUT FIGURE

The measurements are as follows:

Indentation .....	1½ inches	Strap .....	13½ inches
Scye depth .....	9¾ inches	Overshoulder .....	19 inches
Natural waist length .....	17 inches	Blade .....	14 inches
Fashionable waist length .....	18¾ inches	Breast .....	42 inches
Full length whatever style calls for		Waist .....	42 inches

Square down and out from A.

From A to B is the scye depth plus ¼ inch; C is natural waist length; D is fashionable waist length; E is full length; F is halfway between A and B; G is halfway between A and F; square out from G, F, B, C, D and E.

From C to R is ½ indentation; draw a line from A through R to Q and square down; from H to I is ½ breast; I to J is 1½ inches; J to H is 1 inch; square up from H; K is halfway between H and I; K to L is 3½ inches; square down from L to locate M; apply the blade measure from H to L which is 14 inches and square up; N is halfway between H and L; N to O is 1¼ inches; from A to 21 is the same distance as H to O; draw a line from O to 21.

From A to T is 6¾ inches; T to U is 1½ inches; draw a line from A to U; from A to V is ½ breast; square up from V to locate W; draw a line from ¼ inch below W to P; Q to S is ⅛ breast; square down from S and shape the back; from X to Y is 1¼ inches; square down from Y; 1 to 2 is ¾ inch; O to Z is ⅛ breast; point 22 is halfway between Y and M; point 3 is ½ inch above the waistline; shape the sidebody.

From M to 4 is ½ waist; square down from 4; this locates 11; from 11 to 12 is ½ inch less than ⅓ breast; 12 to 15 is ¾ inch; draw a line from 3 to 15; point 5 is halfway between M and 1; point 6 is halfway between L and J; draw a line from 5 through 6 up; from A to W and L to 7 is the strap measure plus ¾ inch; draw a line from 7 to P; from 7 to 23 is ⅜ inch less than the back shoulder width; shape the shoulder and armseye; square forwards from 7 by line 5-6; from 7 to 9 is ⅓ breast plus ¾ inch; also square forwards from 6 by the same line; this locates 30; add ¼ inch at 4 and shape the front edge from 9 through 30 and 4 down; from 9 to 10 is ⅓ breast; 7 to 8 is ⅓ breast; draw a line from 8 to 10 and shape the gorge; from 4 back to 27 is 1¾ inches; from 22 to Y, X to R and 27 to 21 is the waist measure net; shape the side of forepart. Draw a straight line from 20 to 12; this locates point 16; cut out a small V at 16; hollow the bottom of forepart slightly between 3 and 16.

## THE REVER

Draw a straight line from 19 up to 29; sweep from 10 to 29 pivoting at 19; from 12 back to 32 is 2½ inches; sweep from 32 forwards to 13 pivoting at 29; shape the bottom of forepart; make the width of the rever according to style.

## THE SKIRT

Square down from 20 by line 16-20; from 20 to 25 is 9 inches; 25 to 26 is 1½ inches; draw a line from 20 through 26 down; from 20 to 18 is ¼ inch more than from S to 17; 19 to 28 is the same distance as 20 to 18; square down from 13 by the waist line; finish the skirt rounding it ⅝ inch at 26.

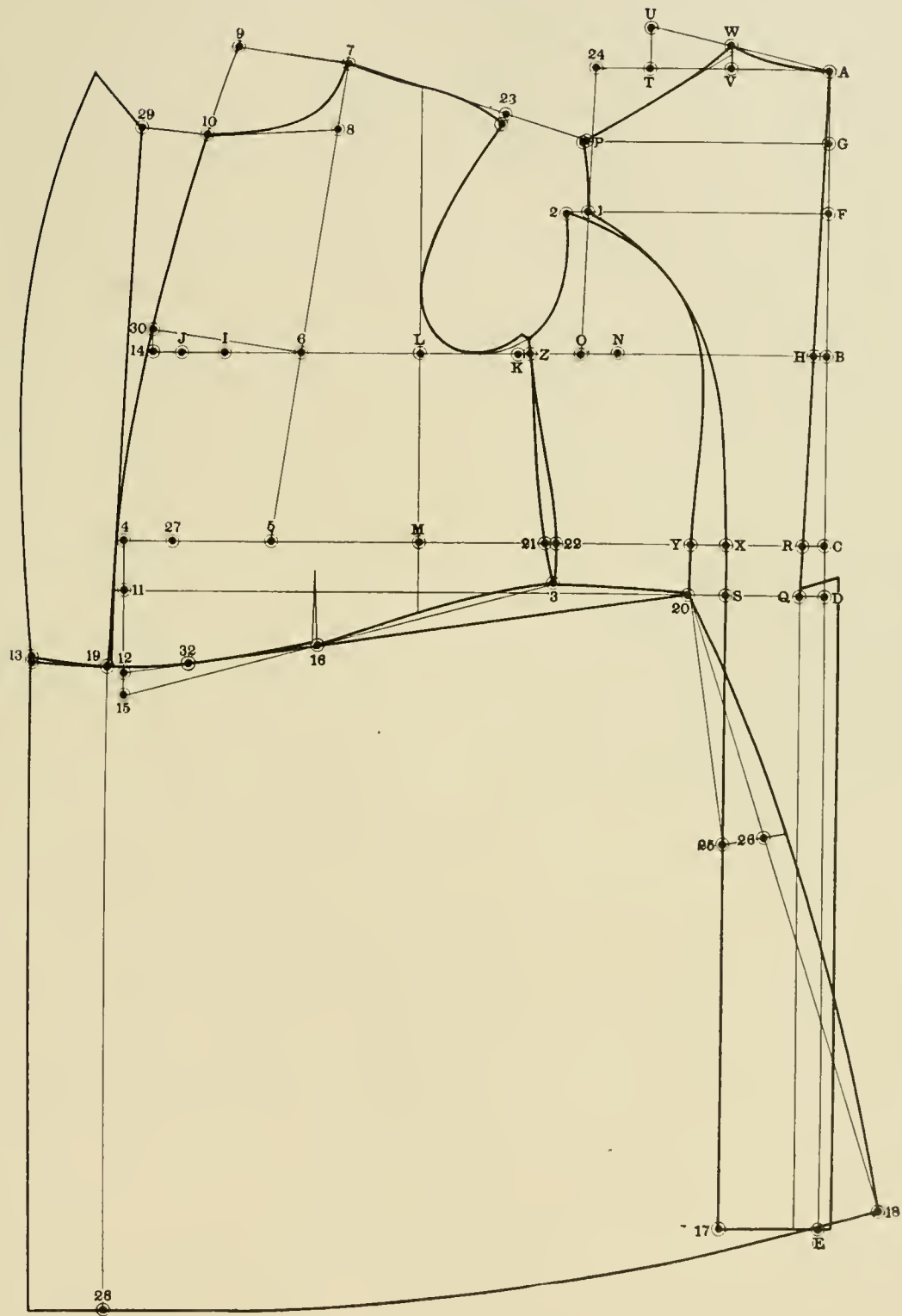

DIAGRAM 50

## DIAGRAM 51

## DOUBLE BREASTED FROCK FOR A CORPULENT FIGURE

The measurements are as follows:

Indentation .....	1½ inches	Strap .....	13¾ inches
Scye depth .....	9¾ inches	Overshoulder .....	19¼ inches
Natural waist length .....	17 inches	Blade .....	14¼ inches
Fashionable waist length .....	18¾ inches	Breast .....	43 inches
Full length according to style		Waist .....	46 inches

Square down and out from A.

From A to B is the scye depth plus ¼ inch; C is natural waist length; D is fashionable waist length; E is full length; F is halfway between A and B; G is halfway between A and F; square out from G, F, B, C, D and E.

From C to R is ½ indentation; draw a line from A through R to Q and square down; from H to I is ½ breast; I to J is 1½ inches; J to 14 is 1 inch; square up from 14; K is halfway between H and I; from K to L is 3½ inches; square down from L to locate M; apply the blade measure from H to L which is 14¼ inches and square up; N is halfway between H and L; from N to O is 1¼ inches; from A to 24 is the same distance as from H to O; draw a line from O to 24.

From A to T is 6¾ inches; T to U is 1½ inches; draw a line from A to U; from A to V is ¼ breast; square up from V to locate W; draw a line from ¼ inch below W to P; from Q to S is ⅛ breast; square down from S and shape the back; from M to 4 is ½ waist; square down from 4; this locates 11; from 11 to 12 is ½ inch less than ¼ breast; 12 to 15 is ¾ inch.

From 4 back to 27 is 1¾ inches; from X to R and 27 to Y is the waist measure net; this waist being 3 inches larger than the breast, there is nothing to come out between the sidebody and the forepart; square down from Y; from 1 to 2 is ¾ inch; O to Z is ½ breast; point 3 is halfway between Y and M; points 21 and 22 are ½ inch above the waistline; shape the sidebody and also the side of forepart, overlapping it between 21 and 22 about ¼ or ⅜ inch; point 5 is halfway between M and 4; 6 is halfway between L and J; draw a line from 5 through 6 up.

From A to W and L to 7 is the strap measure plus ¾ inch; draw a line from 7 to P; from 7 to 23 is ⅜ inch less than the back shoulder width; shape the shoulder and armscye; square forwards from 7 by line 5-6; square forwards from 6 by the same line; this locates point 30; add ¼ inch to 4 for a seam and shape the front edge from 9 through 30 down.

**Notice:**—In this case the distance between the line squared down from 4 and the front edge is about ½ inch; this amount is given there so as to compensate for the V that is being cut out from the forepart and also to give the front edge a regular line.

From 9 to 10 is ¼ breast; 7 to 8 is ⅛ breast; draw a line from 8 to 10 and shape the gorge; draw a line from 22 to 15; now place the square to point 20 and draw a line to 19; point 16 is where the two lines cross; hollow the bottom of forepart slightly between 22 and 16, and cut out a small V at 16.

## THE REVER

Draw a straight line from 19 up to 29; sweep from 10 to 29 pivoting at 19; from 12 back to 32 is 2½ inches; sweep from 32 forwards to 13 pivoting at 29; shape the bottom of forepart; make the width of the rever according to style.

## THE SKIRT

Square down from 20 by line 16-20; from 20 to 25 is 9 inches; from 25 to 26 is 1½ inches; draw a line from 20 through 26; square down from 19 and 13 by the waist line; from 20 to 18 is ¼ inch more than from S to 17; from 19 to 28 is the same distance as 20 to 18; sweep from 32 to 34 pivoting at 28; shape the top of skirt from 20 through 16 to 34; finish the skirt rounding it ⅝ inch at 26.

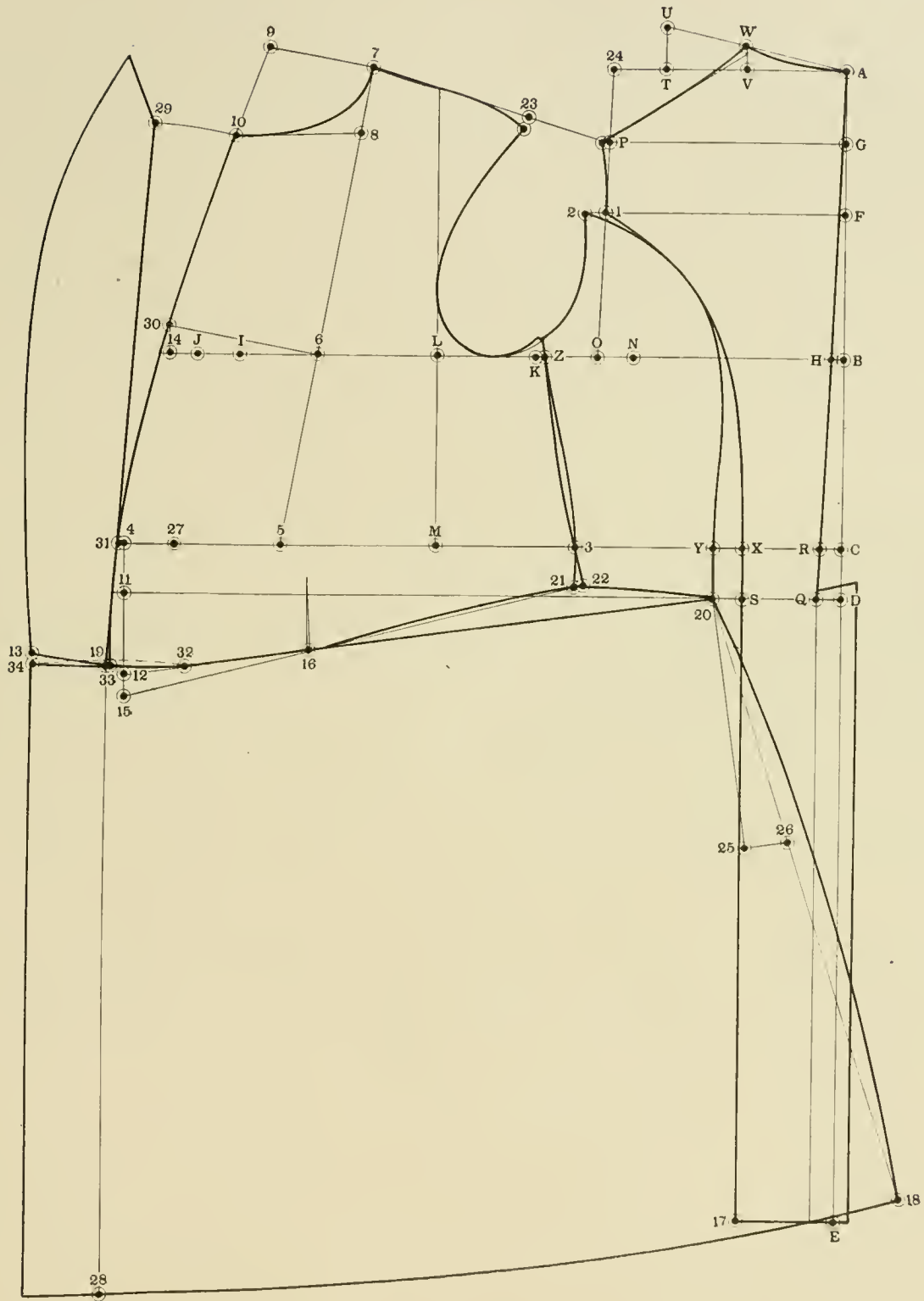

DIAGRAM 51

## DIAGRAM 52

## EVENING DRESS COAT

The measurements are as follows:

Indentation .....	1½ inches	Strap .....	12 inches
Scye depth .....	9 inches	Overshoulder .....	17 inches
Natural waist length .....	16½ inches	Blade .....	12½ inches
Fashionable waist length .....	18¼ inches	Breast .....	36 inches
Full length whatever style calls for		Waist .....	32 inches

Square down and out from A.

From A to B is the scye depth plus ¼ inch; C is natural waist length; D is fashionable waist length; E is full length; F is halfway between A and B; G is halfway between A and F; square out from G, F, B, C, D and E.

From C to R is ½ indentation; draw a line from A through R to Q and square down; from H to I is ½ breast; I to J is 1½ inches; K is halfway between H and I; K to L is 3½ inches; square down from L to locate M; apply the blade measure from H to L which is 12½ inches and square up; N is halfway between H and L; N to O is 1¼ inches; A to 28 is the same distance as from H to O; draw a line from O to 28.

From A to T is 6¾ inches; T to U is 1½ inches; draw a line from A to U; A to V is ⅓ breast; square up from V to locate W; draw a line from ¼ inch below W to P; from Q to S is ⅛ breast or may be made smaller if so desired; square down from S and shape the back; from X to Y is 1¼ inches; square down from Y.

From 1 to 2 is ¾ inch; O to K is ½ breast; point Z is halfway between Y and M; point 3 is ½ inch above the waist line; shape the sidebody; from M to 4 is ½ waist; square down from 4; this locates 11; from 11 to 20 is ½ inch less than ⅓ breast; point 5 is halfway between M and 4; point 6 is halfway between L and J; draw a line from 5 through 6 up; A to W and L to 7 is the strap measure plus ¾ inch; draw a line from 7 to P; 7 to 23 is ⅝ inch less than the back shoulder width; shape the shoulder and armscye.

Square forwards from 7 by line 5-6; 7 to 9 is ⅓ breast; 4 back to 13 is 1½ inches; shape the front edge from 9 through J and 13 down; draw a line from 3 to 20 and shape the bottom of forepart; from 9 to 10 is ⅓ breast; this may be made more or less according to style; 7 to 8 is ⅓ breast; draw a line from 8 to 10 and shape the gorge.

## THE REVER

Draw a straight line from 14 through 27 up; make the width of the rever according to style and also make the length of the rever to correspond with the front and skirt strap; from 4 back to 30 is 2¼ inches; Z to Y, X to R and 30 to 21 is the waist measure net; shape the side of forepart.

## THE SKIRT

From Y to 25 is 9 inches; 25 to 26 is 1½ inches; draw a line from 24 through 26 down; 24 to 19 is ¼ inch more than from S to 17; from 20 to 29 is the same distance as from 24 to 19; draw a line from 19 to 29; from 3 to 12 is ⅝ inch; shape the top of the skirt from 24 through 12 and drop it ¼ inch at 14; from 14 to 15 is 1¾ inches; from 15 to 16 is ⅓ of the distance of 14 to 24.

From 19 to 18 is the same distance as 15 to 16; draw a line from 18 to 16; shape the skirt and finish rounding it ⅝ inch at 26.

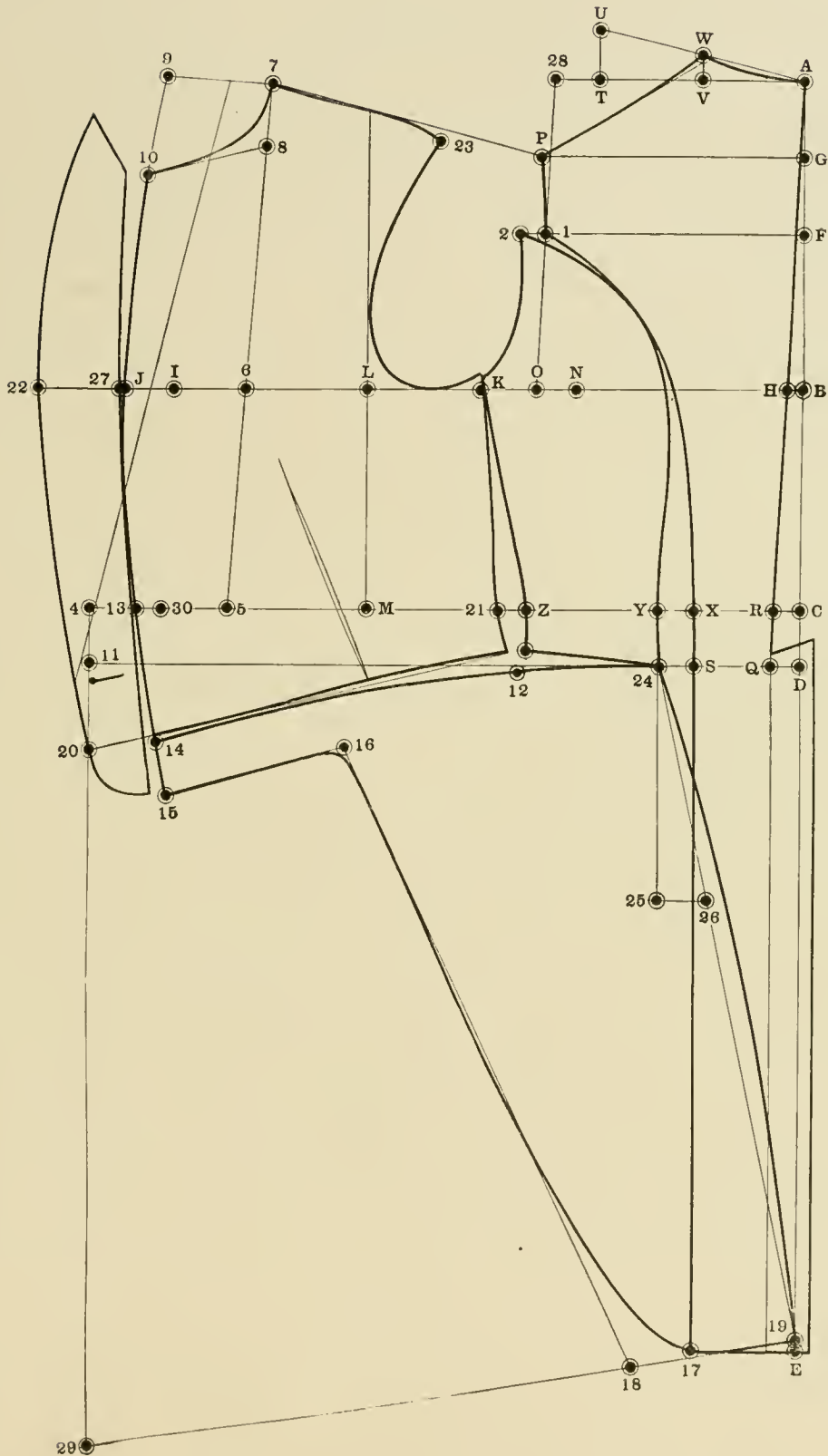

DIAGRAM 52

## DIAGRAM 53

## EVENING DRESS COAT FOR A STOUT FIGURE

The measurements are as follows:

Indentation .....	1½ inches	Strap .....	13 inches
Scye depth .....	9½ inches	Overshoulder .....	18¼ inches
Natural waist length .....	16¾ inches	Blade .....	13½ inches
Fashionable waist length .....	18½ inches	Breast .....	40 inches
Full length according to style		Waist .....	40 inches

Square down and out from A.

From A to B is the scye depth plus ¼ inch; C is natural waist length; D is fashionable waist length; E is full length; F is halfway between A and B; G is halfway between A and F; square out from G, F, B, C, D and E.

From C to R is ½ indentation; draw a straight line from A through R to Q and square down; H to I is ½ breast; I to J is 1½ inches; K is halfway between H and I; K to L is 3½ inches; square down from L to locate M; apply the blade measure from H to L which is 13½ inches and square up; N is halfway between H and L; N to O is 1¼ inches; A to 28 is the same distance as H to O; draw a line from O to 28.

From A to T is 6⅜ inches; T to U is 1½ inches; draw a line from A to U; A to V is ⅓ breast; square up from V to locate W; draw a line from ¼ inch below W to P; from Q to S is ⅛ breast; square down from S and shape the back; from X to Y is 1¼ inches; square down from Y; from 1 to 2 is ¾ inch; O to K is ½ breast; point Z is halfway between Y and M; draw a line from K to Z; point 3 is ½ inch above the waist line; shape the sidebody.

From M to 1 is ½ waist; square down from 1; this locates 11; from 11 to 14 is ½ inch less than ⅓ breast; 14 to 15 is ¾ inch; draw a line from 3 to 15; point 5 is halfway between M and 1; point 6 is halfway between L and J; draw a line from 5 through 6 up; from A to W and L to 7 is the strap measure plus ¾ inch; draw a line from 7 to P; from 7 to 23 is ⅜ inch less than the back shoulder width; shape the shoulder and armseye.

Square forwards from 7 by line 5-6; 7 to 9 is ⅓ breast; from 1 back to 13 is 1½ inches; shape the front edge from 9 through J and 13 down; from 9 to 10 is ⅓ breast; 7 to 8 is ⅛ breast; draw a line from 8 to 10 and shape the gorge; from 1 back to 30 is 1¾ inches; from Z to Y, X to R and 30 to 21 is the waist measure net; shape the side of forepart; draw a straight line from 24 to 11; point 12 is where the two lines cross; cut out a small V at 12; point 27 is ⅝ inch below point 3; shape the top of skirt from 24 through 27 and 12, dropping it ¼ inch at 20; square down from Y; Y to 25 is 9 inches; 25 to 26 is 1½ inches; draw a line from 24 through 26 down; 24 to 19 is ¼ inch more than from S to 17; 15 to 29 is the same distance as 21 to 19; draw a line from 19 to 29; from 20 to 22 is 1¾ inches; 12 to 16 is the same; draw a line from 16 to 22; from 20 to 12 is ⅓ the distance of 20 to 21; 19 to 18 is the same distance as 20 to 12; draw a line from 18 to 16; shape the skirt and finish, rounding it ⅝ inch at 26.

## THE REVER.

The rever is made in the same way as described in the previous diagram.



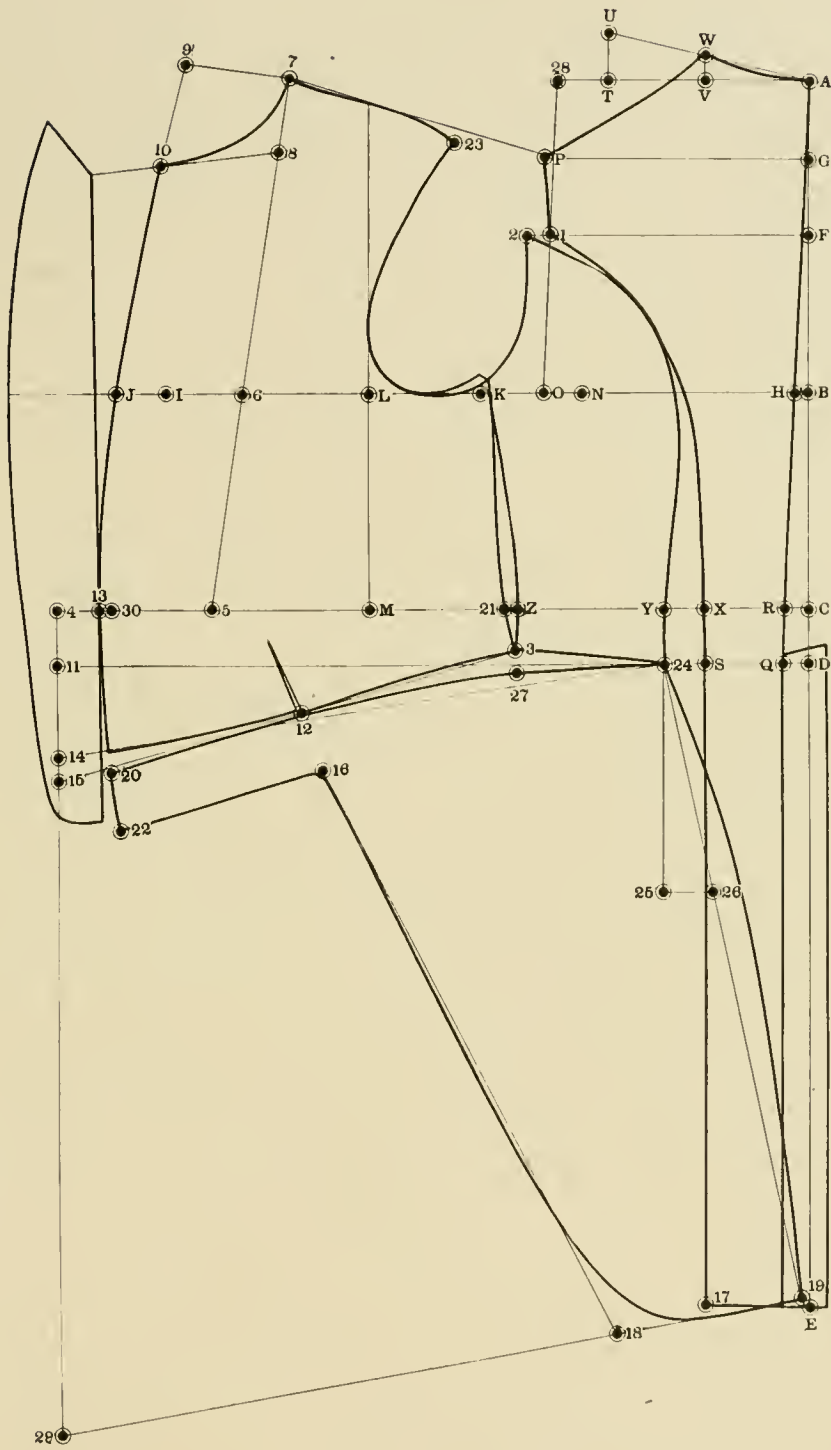

DIAGRAM 53

## DIAGRAM 54

## EVENING DRESS COAT WITH REVER AND SKIRT STRAP IN ONE.

The measurements are as follows:

Indentation .....	1½ inches	Strap .....	12½ inches
Scye depth .....	9¾ inches	Overshoulder .....	17¾ inches
Waist length .....	16½ inches	Blade .....	13 inches
Fashionable waist length .....	18¼ inches	Breast .....	38 inches
Full length according to style.		Waist . . . . .	34½ inches

Square down and out from A.

From A to B is the scye depth plus ¼ inch; C is natural waist length; D is fashionable waist length; E is full length; F is halfway between A and B; G is halfway between A and F; square out from G, F, B, C, D and E.

From C to R is ½ indentation; draw a line from A through R to Q and square down; from H to I is ½ breast; I to J is 1½ inches; K is halfway between H and I; K to L is 3½ inches; square down from L to locate M; apply the blade measure from H to L which is 13 inches and square up; N is halfway between H and L; N to O is 1¼ inches; A to 28 is the same distance as from H to O; draw a line from O to 28.

From A to T is 6¾ inches; T to U is 1½ inches; draw a line from A to U; A to V is ½ breast; square up from V to locate W; draw a line from ¼ inch below W to P; from Q to S is ⅛ breast; square down from S and shape the back; from X to Y is 1¼ inches; square down from Y; from 1 to 2 is ¾ inch; O to K is ½ breast; point Z is halfway between Y and M; point 3 is ½ inch above the waistline; shape the sidebody.

From M to 4 is ½ waist; square down from 4; this locates 11; 11 to 16 is ½ inch less than ½ breast; point 5 is halfway between M and 4; point 6 is halfway between L and J; draw a line from 5 through 6 up; from A to W and L to 7 is the strap measure plus ¾ inch; draw a line from 7 to P; from 7 to 23 is ⅜ inch less than W to P; shape the shoulder and armseye; square forwards from 7 by line 5-6; from 7 to 9 is ½ breast; 4 back to 13 is 1½ inches; draw a line from 9 through J and 13 down.

From 4 back to 30 is 2¼ inches; from Z to Y, X to R and 30 to 21 is the waist measure net; shape the side of forepart; from A to W and 7 to 15 is the length of the waistcoat plus 1 inch; shape the bottom of forepart, hollowing it slightly from 3 to 15; this locates 20; make the distance from 20 to 22 about 1¼ inches and shape the lapel and front edge according to style.

## THE SKIRT.

From Y to 25 is 9 inches; 25 to 26 is 1½ inches; draw a line from 24 through 26 down; from 24 to 19 is ¼ inch more than from S to 17; from 16 to 29 is the same distance as from 24 to 19; draw a line from 19 to 29; from 20 to 12 is ⅓ the distance of from 20 to 24; from 19 to 18 is the same distance as from 20 to 12; draw a line from 18 to 12; from 3 to 27 is ⅝ inch; shape the top of skirt from 24 through 27, dropping it ¼ inch at 12. Finish the skirt rounding it ⅝ inch at 26.

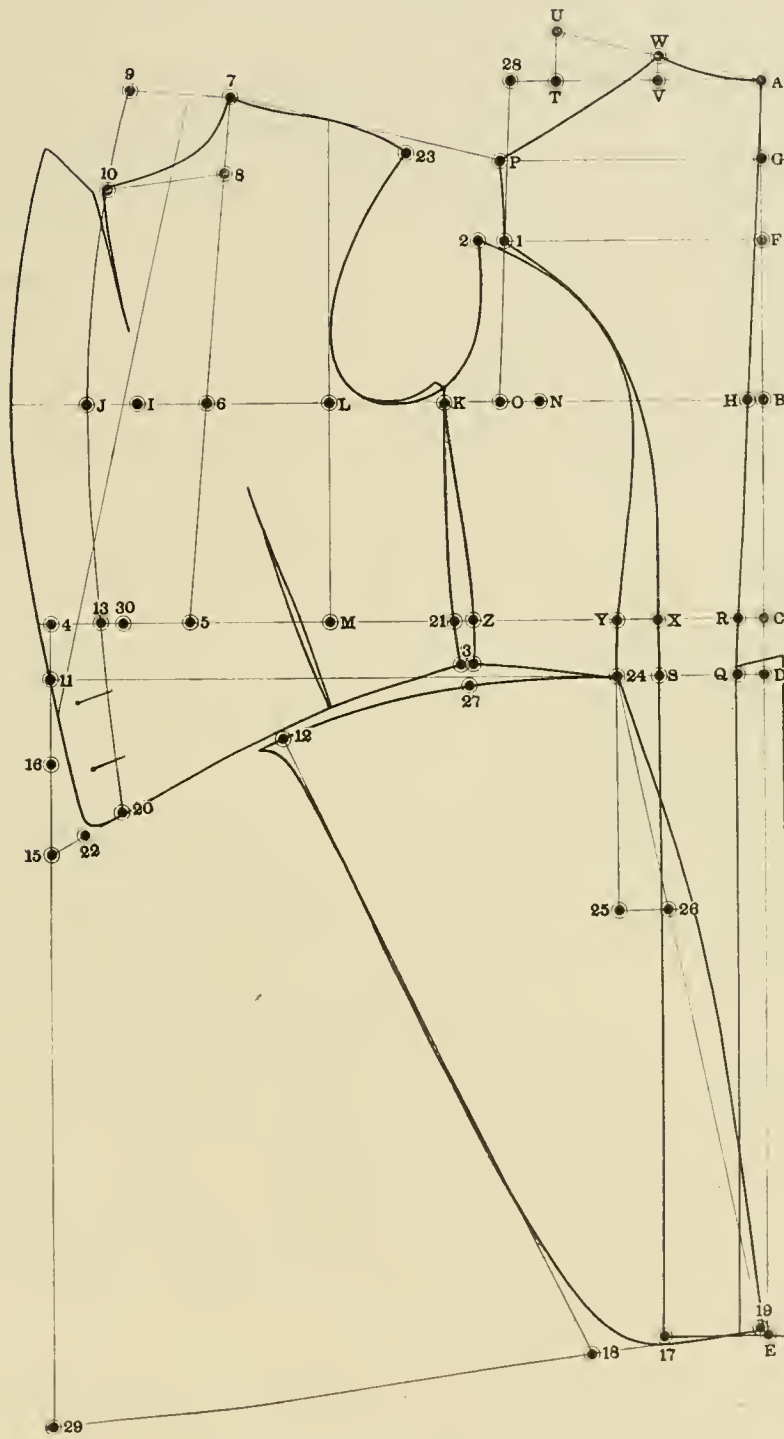

DIAGRAM 54

## DIAGRAM 55

This coat is the same style as Diagram 54, except that it is for a Stout Figure.

The measurements are as follows:

Indentation .....	1½ inches	Strap .....	13½ inches
Scye depth .....	9¾ inches	Overshoulder .....	19 inches
Natural waist length .....	17 inches	Blade .....	14 inches
Fashionable waist length .....	18½ inches	Breast .....	42 inches
Full length whatever style calls for		Waist .....	42 inches

Square down and out from A.

From A to B is the scye depth plus ¼ inch; C is natural waist length; D is fashionable waist length; E is full length; F is halfway between A and B; G is halfway between A and F; square out from G, F, B, C, D and E.

From C to R is ½ the indentation; draw a line from A through R to Q and square down; H to I is ½ breast; I to J is 1½ inches; K is halfway between H and I; K to L is 3½ inches; square down from L to locate M; apply the blade measure from H to L which is 14 inches and square up; N is halfway between H and L; N to O is 1¼ inches; A to 28 is the same distance as H to O; draw a line from O to 28.

From A to T is 6¾ inches; T to U is 1½ inches; draw a line from A to U; from A to V is ½ breast; square up from V to locate W; draw a line from ¼ inch below W to P; Q to S is ⅛ breast; square down from S and shape the back; from X to Y is 1¼ inches; square down from Y; from 1 to 2 is ¾ inch; O to K is ½ breast; point Z is halfway between Y and M; point 3 is ½ inch above the waistline; shape the sidebody.

From M to 4 is ½ waist; square down from 4; this locates 11; from 11 to 14 is ½ inch less than ½ breast; point 5 is halfway between M and 4; point 6 is halfway between L and J; draw a line from 5 through 6 up; from A to W and L to 7 is the strap measure plus ¾ inch; draw a line from 7 to P; from 7 to 23 is ⅜ inch less than W to P; shape the shoulder and armscye; square forwards from 7 by line 5-6; from 7 to 9 is ½ breast; from 4 back to 13 is 1½ inches; draw a line from 9 through J and 13 down.

From 9 to 10 is ⅛ breast; 7 to 8 is ⅛ breast; draw a line from 8 to 10 and shape the gorge; from 4 back to 30 is 1¾ inches; from Z to Y, X to R and 30 to 21 is the waist measure net; shape the side of forepart; from A to W and 7 to 15 is the length of the waistcoat plus 1 inch; shape the bottom of forepart from 3 to 15.

## THE SKIRT.

From Y to 25 is 9 inches; 25 to 26 is 1½ inches; draw a line from 24 through 26 down; from 24 to 19 is ¼ inch more than from S to 17; from 14 to 29 is the same distance as 24 to 19; draw a line from 19 to 29; from 20 to 12 is ⅓ the distance of from 20 to 24; 19 to 18 is the same distance as from 20 to 12; draw a line from 18 to 12; from 3 to 27 is ⅝ inch; shape the top of skirt and finish.

NOTE:—The only difference between this coat and the previous coat is that this coat being for a stout figure, has a small V cut out at 12, and the other dress coat has a fish cut out.

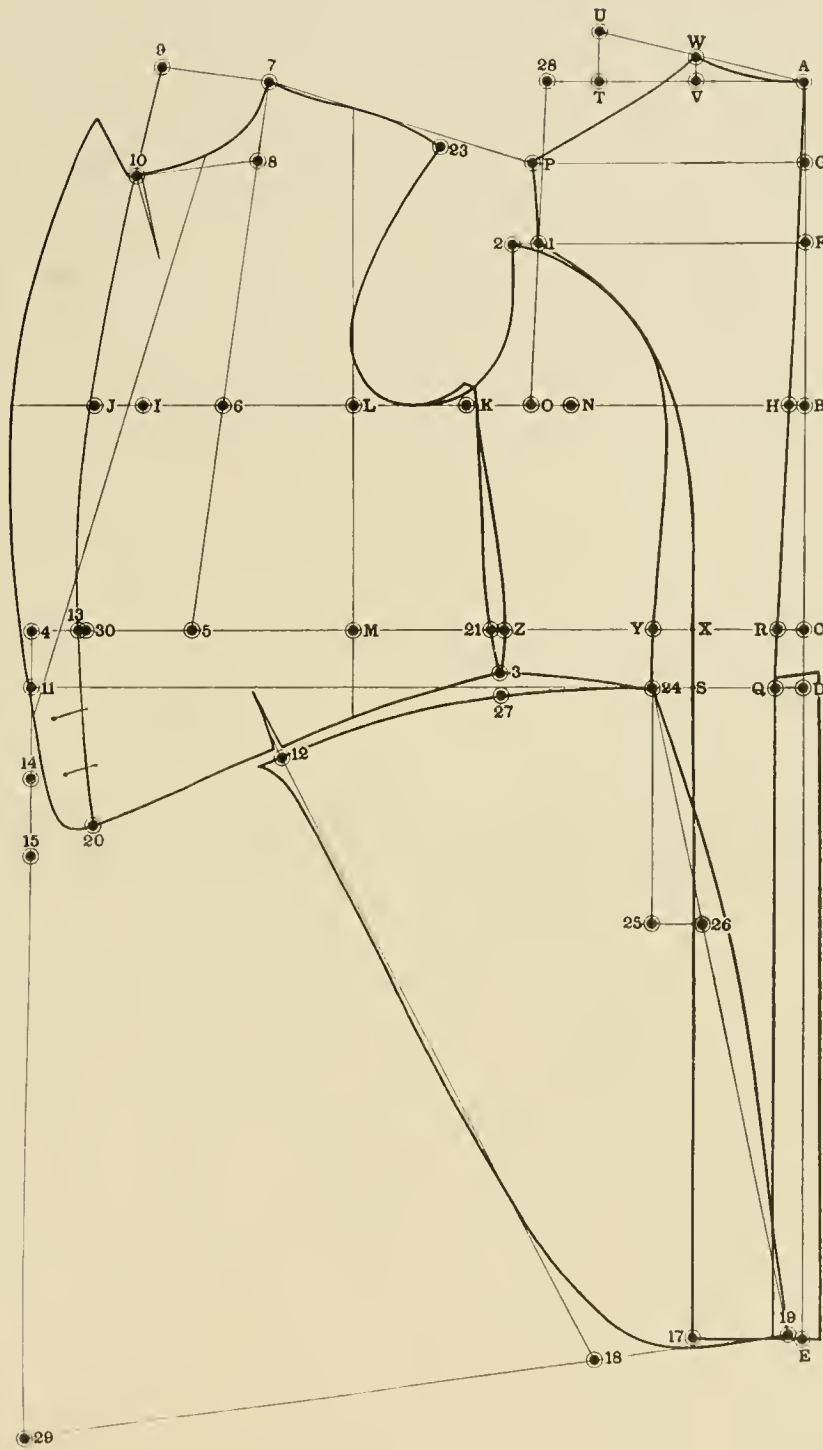

DIAGRAM 55

## DIAGRAM 56

## SINGLE-BREASTED OVERCOAT.

This overcoat is neither a shapely overcoat nor a loose overcoat; it is just a plain coat which never is out of style. The measurements for overcoats are taken over the waistcoats in all cases, the same as for any other coat and the additions are made in the cutting.

The measurements as taken over the waistcoat are as follows:

Scye depth .....	9 inches	Blade .....	12½ inches
Waist length .....	16½ inches	Breast .....	36 inches
Full length whatever style calls for		Waist .....	32 inches
Strap .....	12 inches	Hip .....	38 inches
Overshoulder .....	17 inches		

Square down and out from A.

From A to B is the scye depth plus ¼ inch; B to C is ¾ inch; this is the difference between the undercoat and the overcoat; from A to D is the waist length plus ¾ inch; D to 23 is 6 inches; A to E is full length; F is halfway between A and C; G is halfway between A and F; square out from G, B, C, D, 23 and E.

From D to 2 is ½ indentation; E to 22 is the same; this not being a shapely coat, you do not swing that line out at 22; shape the center of back from F to 2 and down; this locates 1; from 1 to 21 in this case is 1½ inches. If the material for the overcoat is to be extremely heavy, the distance from 1 to 21 may be as much as 2 inches and no more; from 3 to 25 is the same distance as from 1 to 21; from 21 to H is ½ of 36 breast; H to I is 1¾ inches; I to J is ¾ inch; K is halfway between 21 and H; K to L is 3½ inches; square down from L to locate Q.

Apply the blade measure from 21 to L which is 12½ inches and square up; go back from L to 15, ½ inch or ⅓ of the distance of from 1 to 21; this gives ⅓ of the increase to the forepart and ⅔ of the increase from the front of the armseye backwards; square up from 15; point M is halfway between 1 and 15; from M to N is 1¼ inches; square up from N; from N to 1 is 1 inch; from N back to P in this case is ¼ inch; from 22 to 28 is the same distance as from 1 to P. This distance may be made greater if so desired.

Draw a line from 28 to P; from A to 8 is 6¾ inches; 8 to 9 is 1½ inches; draw a line from A to 9; from A to 10 is ⅓ breast; square up from 10 to locate 11; draw a line from ¼ inch below 11 to O and shape the back; from Q to S is ½ of 32 waist; point T is halfway between Q and S; point U is halfway between L and 1; draw a line from T through U up.

From A to 11 and L to V is the strap measure plus ¾ inch; draw a line from V to O; from V to Z is ⅔ inch less than the back shoulder width; shape the shoulder and armseye; square forwards from V by line T-U; from V to W is ⅓ breast plus ½ inch; draw a rounding line from W to J; make the depth of the gorge from W to X according to style; V to Y is ⅓ breast; draw a line from Y through X and shape the gorge.

If the material is of a medium weight the distance from J to 12 is 1¾ inches; if the material is heavy weight the distance may be 2 to 2¼ inches but no more; if the material is extra light weight, 1½ inches is enough; from S to 13 is the same distance as J to 12.

From Q to R is ½ the indentation; draw a line from R through S; square down from 13 by line R-S; this locates points 27 and 16; there being no under-arm fish in this coat, the distance from 27 to 7 is the same as from H to 12; from 19 to 25 and 7 to 20 is the hip measure; from 20 back to 19 is 2 inches; square up from 19 to 5; draw a line from 5 through 20 down and shape the side of forepart; from 5 to 29 is the same distance as from 5 to 28; from 16 to 17 is ⅓ breast; shape the bottom of forepart and finish.

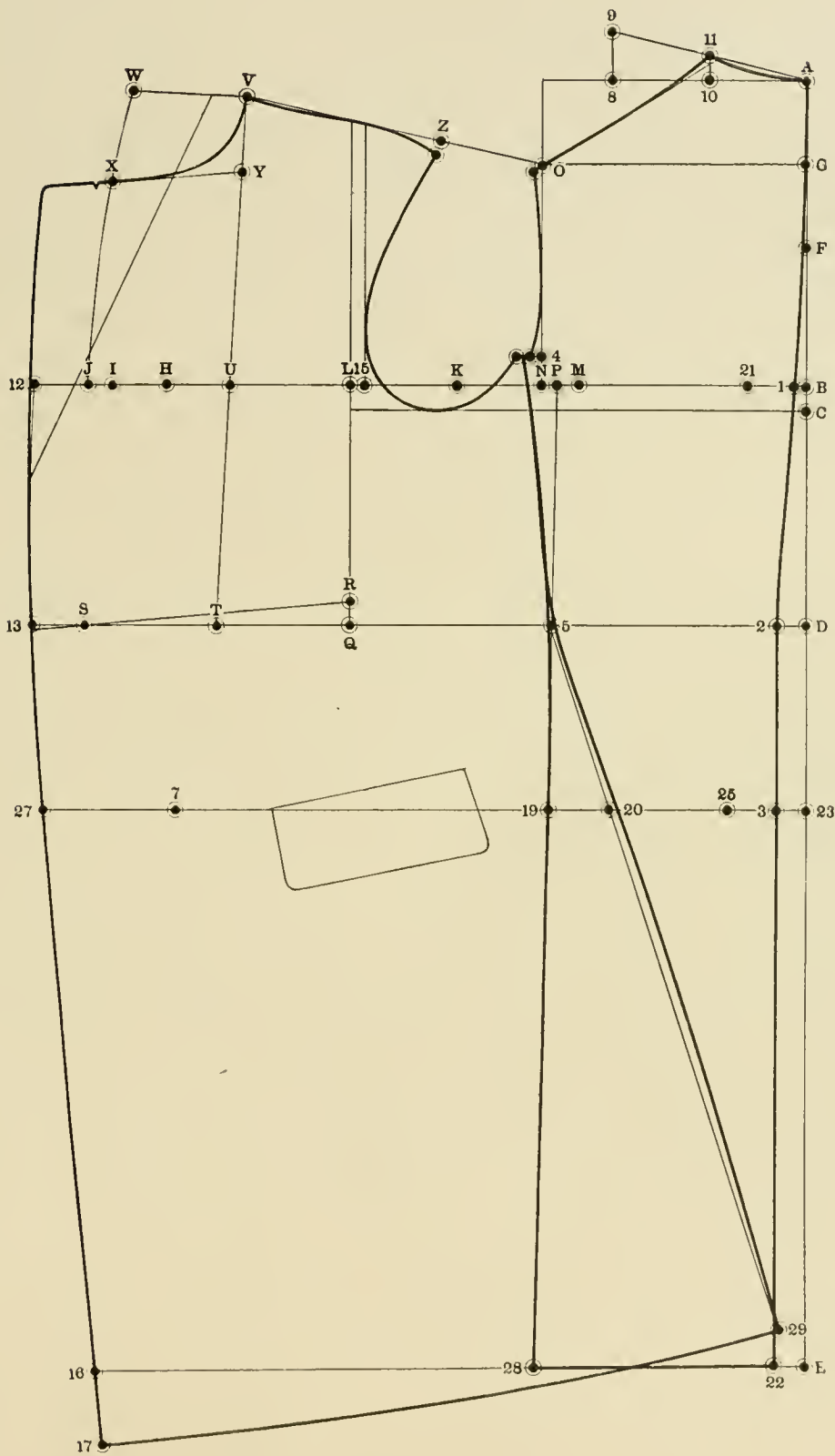

DIAGRAM 56

## DIAGRAM 57

## SINGLE-BREASTED SHAPELY OVERCOAT.

The measurements as taken over the waistcoat are as follows:

Indentation .....	1½ inches	Overshoulder .....	17½ inches
Scye depth .....	9⅜ inches	Blade .....	13 inches
Waist length .....	17 inches	Breast .....	38 inches
Full length whatever style calls for.		Waist .....	34½ inches
Strap .....	12½ inches	Hip .....	40½ inches

Square down and out from A.

From A to B is the scye depth plus ¼ inch; B to C is ¾ inch; A to D is the waist length plus ¾ inch; D to 23 is 6 inches; A to E is full length; F is halfway between A and C; G is halfway between A and F; square out from G, B, C, D, 23 and E.

From D to 2 is ½ the indentation; E to 22 is ½ the distance of D to 2; shape the center of back from F to 2 and 2 to 22; from 1 to 21 is 1½ inches; 21 to H is ½ breast; H to I is 1¾ inches; I to J is ¾ inch; K is halfway between 21 and H; K to L is 3½ inches; square down from L to locate Q; apply the blade measure from 21 to L which is 13 inches and square up.

From L back to 15 is ½ inch; square up from 15; point M is halfway between 1 and 15; from M to N is 1¼ inches; square up from N; from N to 4 is 1 inch; point P is halfway between M and N; from 22 to 28 is the same distance as from 1 to P; this may be made wider if so desired. Draw a line from 28 to P; from A to 8 is 6⅜ inches; 8 to 9 is 1½ inches; draw a line from A to 9; from A to 10 is ⅓ of 38 breast; square up from 10 to locate 11; draw a line from ¼ inch below 11 to O and shape the back.

From Q to S is ½ of 34 ½ waist; point T is halfway between Q and S; point U is halfway between L and I; draw a line from T through U up; from A to 11 and L to V is the strap measure plus ¾ inch; draw a line from V to O; from V to Z is ⅜ inch less than 11 to O; shape the shoulder and armseye; square forwards from V by line T-U; V to W is ⅓ breast plus ½ inch; draw a rounding line from W to J; from W to X is ⅓ breast or according to style; V to Y is ⅛ breast; draw a line from Y through X and shape the gorge; from S to 13 is 1¾ inches; J to 12 is the same.

From Q to R is ½ the indentation; draw a line from R through S; square down from 13 by line R-S; this locates point 27-16; from 27 to 7 is ½ inch less than from H to 12; from 3 to 25 is the same distance as from 1 to 21; from 19 to 25 and 7 to 20 is the hip measure; from 20 back to 6 is 2 inches; square up from 6 to locate 18; draw a line from 18 through 20 down and shape the side of forepart.

From 18 to 29 is the same distance as from 5 to 28; 16 to 17 is ⅛ breast; shape the bottom of forepart and finish. Cut out an underarm fish and lower the side of forepart as from 31 to 32, ½ the amount that has been taken out at the fish.



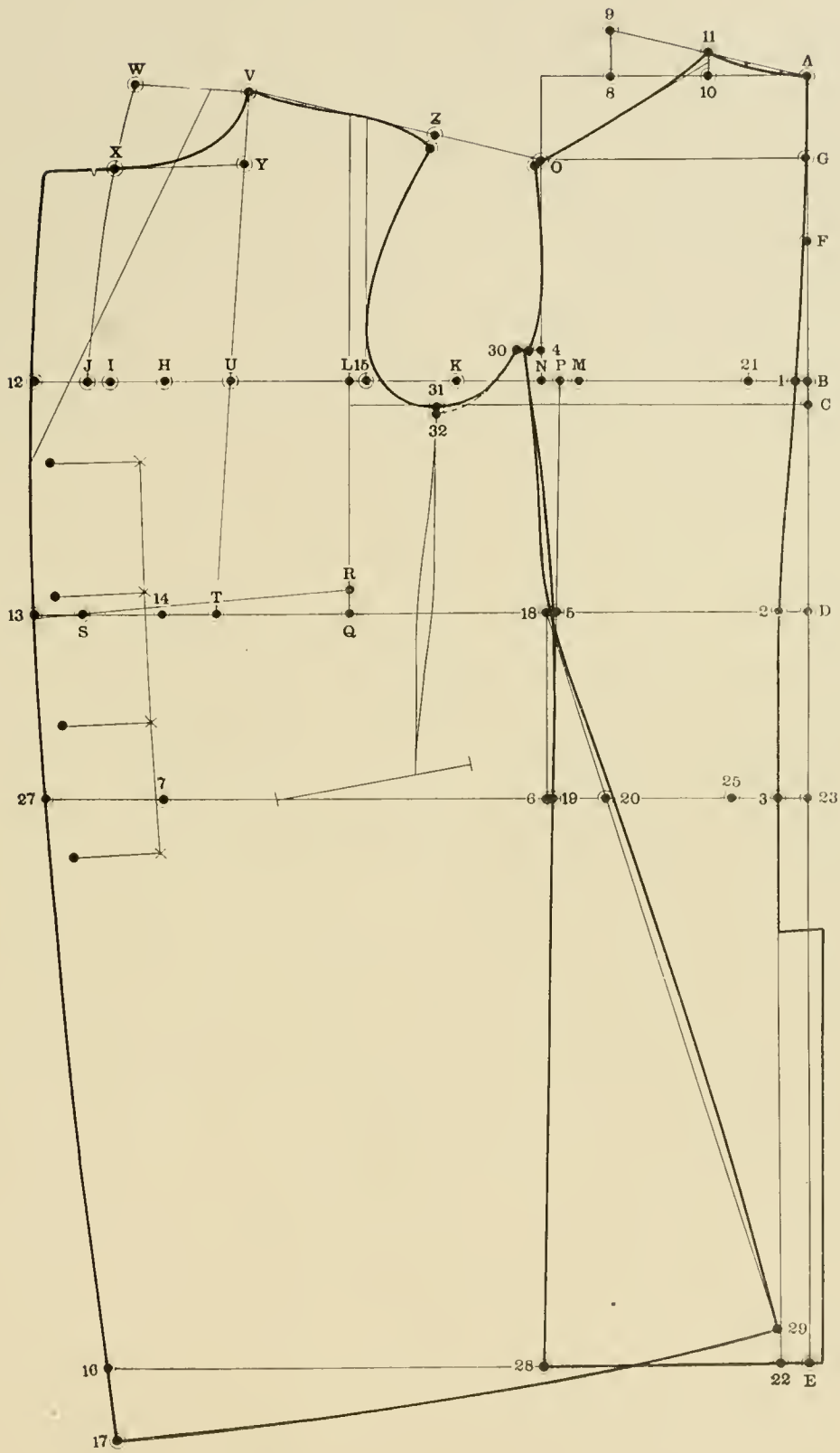

DIAGRAM 57

## DIAGRAM 58

This coat is made the same as shown on diagram 57 with the exception that from J to 12 is  $3\frac{1}{2}$  to  $3\frac{3}{4}$  inches and from S to 13 is the same. This would set the buttons  $\uparrow$  to  $\uparrow\frac{1}{2}$  inches from the edge.

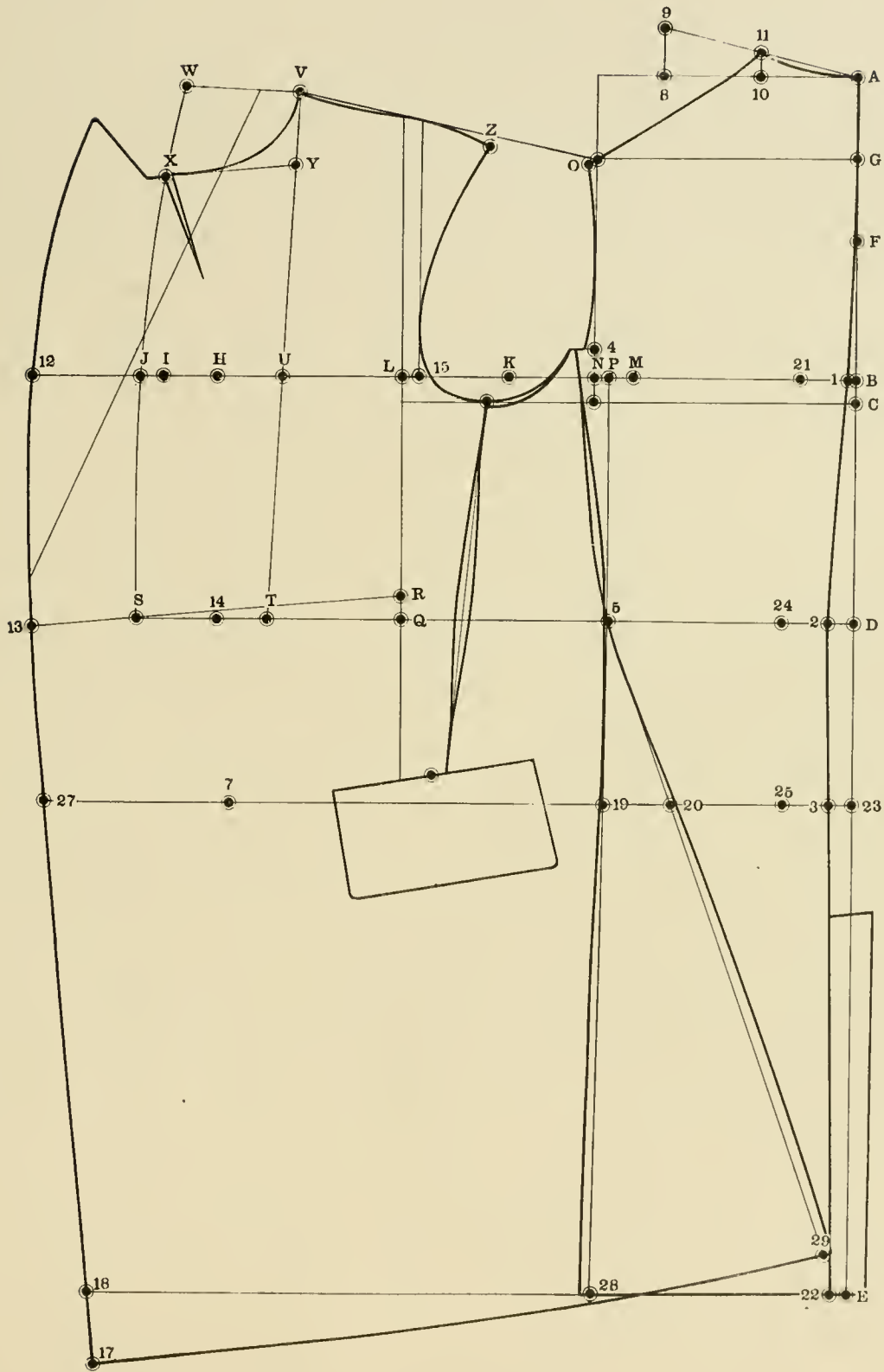

DIAGRAM 58

## DIAGRAM 59

## SHAPELY OVERCOAT FOR A STOUT FIGURE.

The measurements as taken over the waistcoat are as follows:

Indentation .....	1½ inches	Overshoulder .....	19 inches
Scye depth .....	9¾ inches	Blade .....	14 inches
Waist length .....	17 inches	Breast .....	42 inches
Full length according to style.		Waist .....	42 inches
Strap .....	13½ inches	Hip .....	44 inches

Square down and out from A.

From A to B is the scye depth plus ¼ inch; B to C is ¾ inch; A to D is waist length plus ¾ inch; D to 23 is 6 inches; A to E is full length; F is halfway between A and C; G is halfway between A and F; square out from G, B, C, D, 23 and E.

From D to 2 is ½ indentation; shape the center of back from F to 2 and square down from 2; this locates 1-3; from 1 to 21 is 1½ inches; 2 to 24 and 3 to 25 are the same; from 21 to H is ½ of 42 breast; H to I is 1¾ inches; I to J is ¾ inch; square up from J; K is halfway between 21 and H; K to L is 3½ inches; square down from L to locate Q; apply the blade measure from 21 to L which is 14 inches and square up; from L back to 15 is ½ inch

Square up from 15; point M is halfway between 1 and 15; M to N is 1¼ inches; square up from N; from N to 4 is 1 inch; N to P is ½ inch; 22 to 28 is the same distance as from 1 to P; draw a line from P to 28; from A to 8 is 6⅜ inches; 8 to 9 is 1½ inches; draw a line from A to 9; A to 10 is ⅙ of 42 breast; square out from 10 to locate 11; draw a line from ¼ inch below 11 to O and shape the back.

From Q to S is ½ waist; point T is halfway between Q and S; point U is halfway between L and I; draw a line from T through U up; from A to 11 and L to V is the strap measure plus ¾ inch; draw a line from V to O; from V to Z is ⅜ inch less than the back shoulder width; shape the shoulder and arm-scye; square forwards from V by line T-U; V to W is ⅙ breast plus ½ inch; square out from U by the same line; this locates 26; draw a line from W to 26; from W to X is ⅙ breast; V to Y is ⅙ breast; draw a line from Y to X and shape the gorge.

From 26 to 12 is 1¾ inches; S to 13 is the same; from Q to R is ½ indentation; draw a line from R through S; square down from 13 by line R-S and shape the front edge; from S back to 14 is 2½ inches; from 27 to 7 is ½ inch less than 13 to 14; from 5 to 24 and 14 to 18 is the waist measure net; square down from 18 to locate 6; from 6 to 20 is 2 inches; draw a line from 18 through 20 down and shape the side of forepart; from 18 to 29 is the same distance as from 5 to 28.

From 16 to 17 is ⅙ breast; draw a straight line from 29 to 17; now apply the hip measure from the side of backpart to 25 and from 7 to 19; this leaves a surplus from 19 to 20 in this case of 1¼ inches; split the forepart down to the pocket; open the pocket to the front V allowing it to open under the arm 1¼ inches the same as shown on diagram 18 and 19.

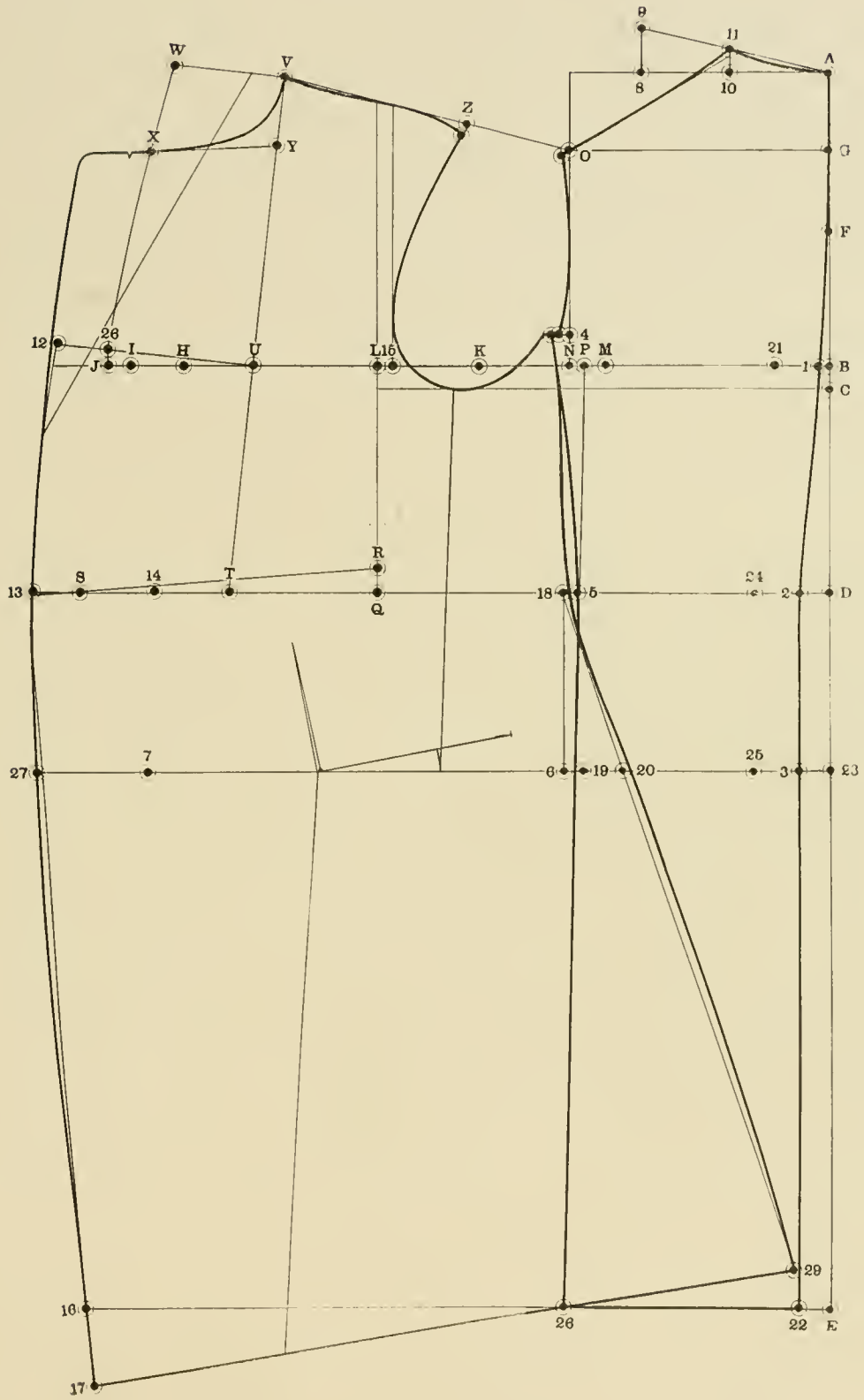

DIAGRAM 59

## DIAGRAM 60

## DOUBLE-BREASTED OVERCOAT FOR STOUT FIGURE.

The measurements for this coat are the same as given for diagram 59. The coat is made in the same way with the exception of the button-stand which is: from 26 to 12 is  $3\frac{1}{2}$  inches, or  $3\frac{3}{4}$  inches; S to 13 is the same; square down from 13 by line R-S; from S to 14 is  $2\frac{1}{2}$  inches; 27 to 7 is  $\frac{1}{2}$  inch less than 13 to 14.

Finish the coat in the same manner as described for diagram 59.

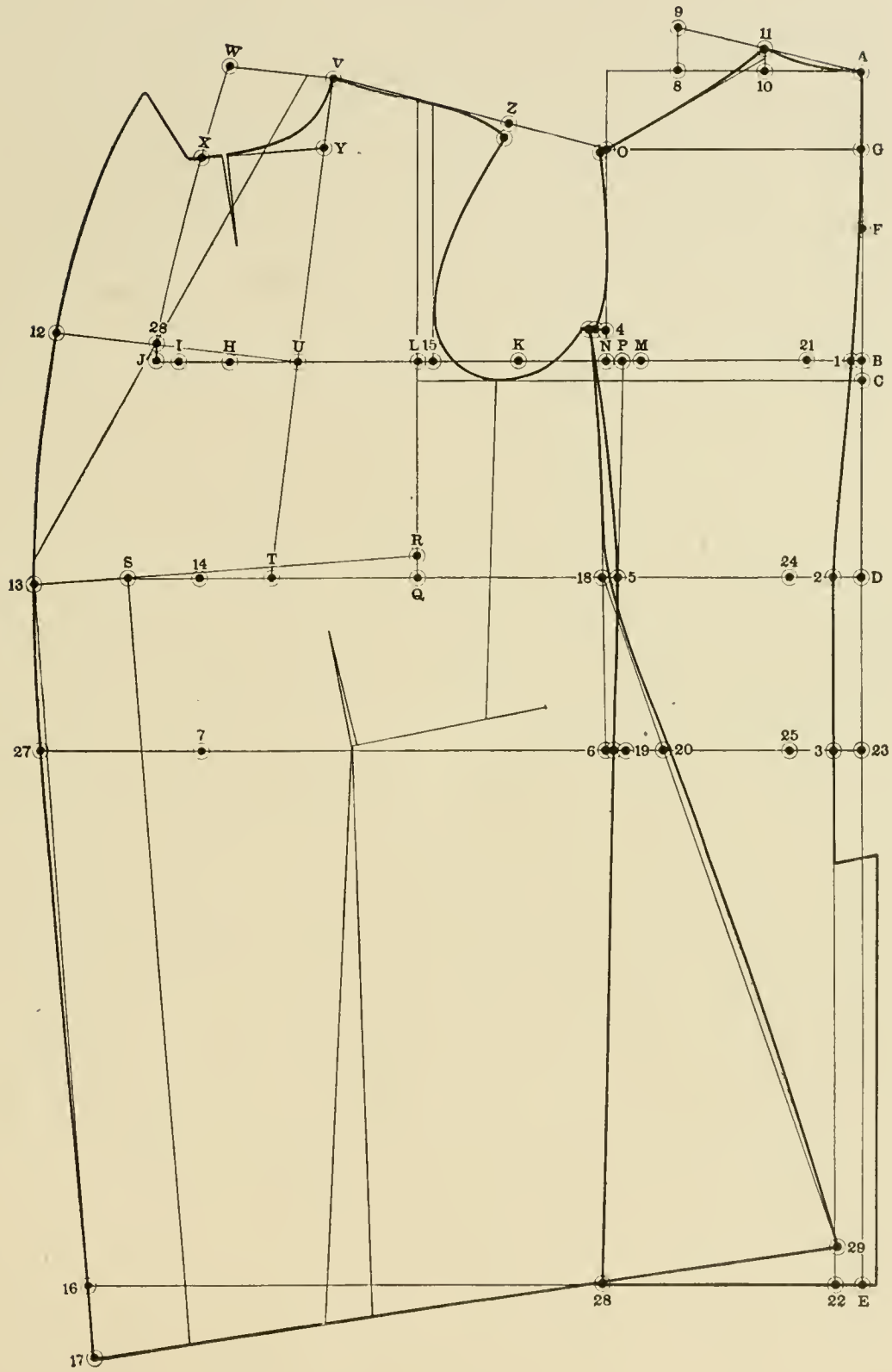

DIAGRAM 60

## DIAGRAM 61

## SINGLE-BREASTED LOOSE-HANGING OVERCOAT.

This overcoat is neither a shapely coat nor a box overcoat, but is just between the two.

The measurements as taken over the waistcoat are as follows:

Scye depth .....	9 inches	Overshoulder .....	17 inches
Waist length .....	16½ inches	Blade .....	12½ inches
Full length according to style		Breast .....	36 inches
Strap .....	12 inches	Waist .....	32 inches

Square down and out from A.

From A to B is the scye depth plus ¼ inch; B to C is ¾ inch; A to D is waist length, plus ¾ inch; D to 23 is 6 inches; A to E is full length; F is halfway between A and C; G is halfway between A and F; square out from G, B, C, D, 23 and E.

From D to 2 is ¾ inch; draw a line from F through 2 down; this locates 22; square forwards from 22; from 1 to 21 is 1½ inches or may be more if so desired; 21 to H is ½ breast; H to I is 1½ inches; I to J is ¾ inch; K is halfway between 21 and H; K to L is 3½ inches; square down from L to locate Q; apply the blade measure from 21 to L which is 12½ inches and square up; from L back to 15 is ½ inch.

Point M is halfway between 1 and 15; from M to N is 1¼ inches; square up and down from N; this locates point 19; from 19 to 6 is 1½ inches; 19 to 20 is 3½ inches or make the distance from 6 to 20, 5 inches; draw a line from N through 6; this locates 5; from 4 to 25 is ½ inch; draw a line from 25 through 20 down; from 25 to 18 is the same distance as from 25 to 5.

From A to 8 is 6⅜ inches; 8 to 9 is 1½ inches; draw a line from A to 9; from A to 10 is ½ breast; square up from 10 to locate 11; draw a line from ¼ inch below 11 to O and shape the back. This being a draped coat, we lengthen the front edge in the following manner: from 3 to S is ½ waist; point T is halfway between Q and S; point U is halfway between L and I; draw a line from T through U up.

From A to H and L to V is the strap measure plus ¾ inch; draw a line from V to O; from V to Z is ⅜ inch less than the back shoulder width; shape the shoulder and armscye; square forwards from V by line T-U; V to W is ½ breast plus ¾ inch; draw a rounding line from W to J; W to X is ½ breast; V to Y is ⅜ breast; draw a line from Y to X and shape the gorge; J to 12 is 1¾ inches; S to 13 is the same; Q to R is 1 inch; draw a line from R through S; square down from 13 by line R-S; this locates 16; from 16 to 17 is ⅜ breast; shape the front edge, bottom of forepart and finish.



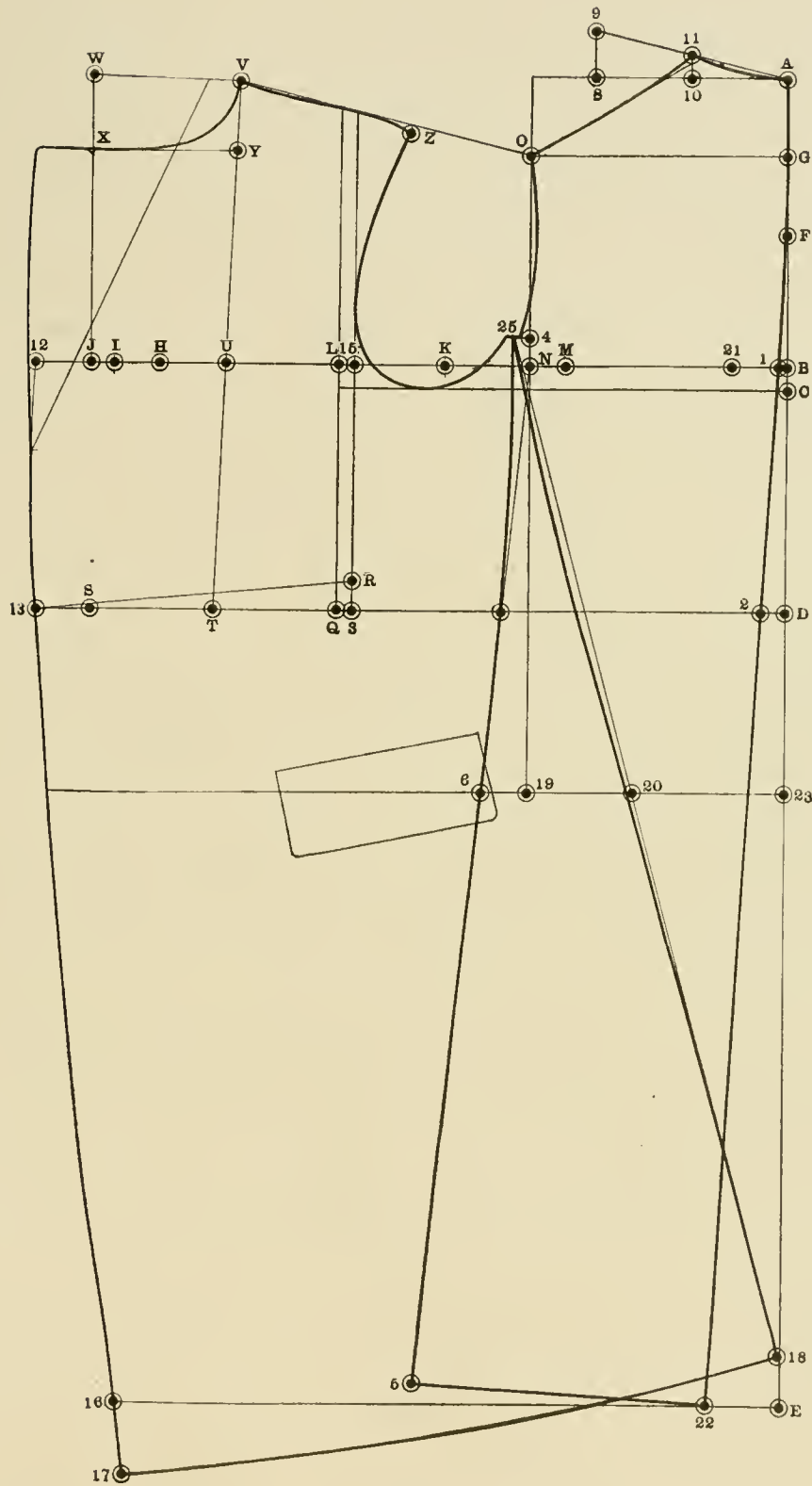

DIAGRAM 61

## DIAGRAM 62

## STRAIGHT-HANGING OVERCOAT FOR A STOUT FIGURE.

The measurements as taken over the waistcoat are as follows:

Scye depth .....	10 inches	Overshoulder .....	19 $\frac{1}{4}$ inches
Waist length .....	17 $\frac{1}{2}$ inches	Blade .....	14 $\frac{1}{4}$ inches
Full length whatever style calls for.		Breast .....	43 inches
Strap .....	13 $\frac{3}{4}$ inches	Waist .....	43 inches

Square down and out from A.

From A to B is scye depth plus  $\frac{1}{4}$  inch; B to C is  $\frac{3}{4}$  inch; A to D is waist length plus  $\frac{3}{4}$  inch; D to 23 is 6 inches; A to E is full length; F is halfway between A and C; G is halfway between A and F; square out from G, B, C, D, 23 and E.

From D to 2 is  $\frac{3}{4}$  inch; draw a line from F through 2 down; this locates 22; square forwards from 22 and shape the center of back; from 1 to 21 is  $1\frac{1}{2}$  or  $1\frac{3}{4}$  inches; 21 to H is  $\frac{1}{2}$  breast; H to I is  $1\frac{1}{2}$  inches; I to J is  $\frac{3}{4}$  inch; K is halfway between 21 and H; K to L is  $3\frac{1}{2}$  inches; square down from L to locate Q; apply the blade measure from 21 to L which is  $14\frac{1}{4}$  inches and square up.

From L back to 15 is  $\frac{1}{2}$  inch or  $\frac{1}{3}$  the distance of from 1 to 21; square up and down from 15; this locates point 3; point M is halfway between 1 and 15; M to N is  $1\frac{1}{4}$  inches; square up and down from N; from N to 4 is 1 inch; from A to 8 is  $6\frac{3}{8}$  inches; 8 to 9 is  $1\frac{1}{2}$  inches; draw a line from A to 9; from A to 10 is  $\frac{1}{8}$  breast; square up from 10 to locate 11; draw a line from  $\frac{1}{4}$  inch below 11 to O and shape the back.

From 19 to 6 is  $1\frac{1}{2}$  inches; 19 to 20 is  $3\frac{1}{2}$  inches; draw a line from 1 through 6 down; this locates point 5; from 4 to 25 is  $\frac{1}{2}$  inch; draw a line from 25 through 20 down; from 25 to 18 is the same distance as 25 to 5; hollow the side of the forepart about  $\frac{1}{4}$  inch at the waist; from 3 to S is  $\frac{1}{2}$  waist; point T is halfway between Q and S; point U is halfway between L and I; draw a line from T through U up.

From A to 11 and L to V is the strap measure plus  $\frac{3}{4}$  inch; draw a line from V to O; from V to Z is  $\frac{3}{8}$  inch less than the back shoulder width; shape the shoulder and armscye; square forwards from V by line T-U; V to W is  $\frac{1}{8}$  breast plus  $\frac{1}{2}$  inch; draw a rounding line from W to J; W to X is the depth of gorge desired; V to Y is  $\frac{1}{8}$  breast; draw a line from Y through X and shape the gorge.

From Q to R is 1 inch; draw a line from R through S; from S to 13 is  $1\frac{3}{4}$  inches; J to 12 is the same; square down from 13 by line R-S; this locates 16; from 16 to 17 is  $\frac{1}{8}$  breast; draw a straight line from 17 to 18.

After the forepart is cut out you may split the forepart as from P down to the pocket, also open up the pocket to 7 and split the front from 7 to 24; manipulate the forepart the same as shown on diagrams 18 and 19; but in a case of this kind you may add to the side of the forepart  $1\frac{1}{2}$  to 2 inches the same as shown on diagram 65, so as not to reduce the drapery of the coat.

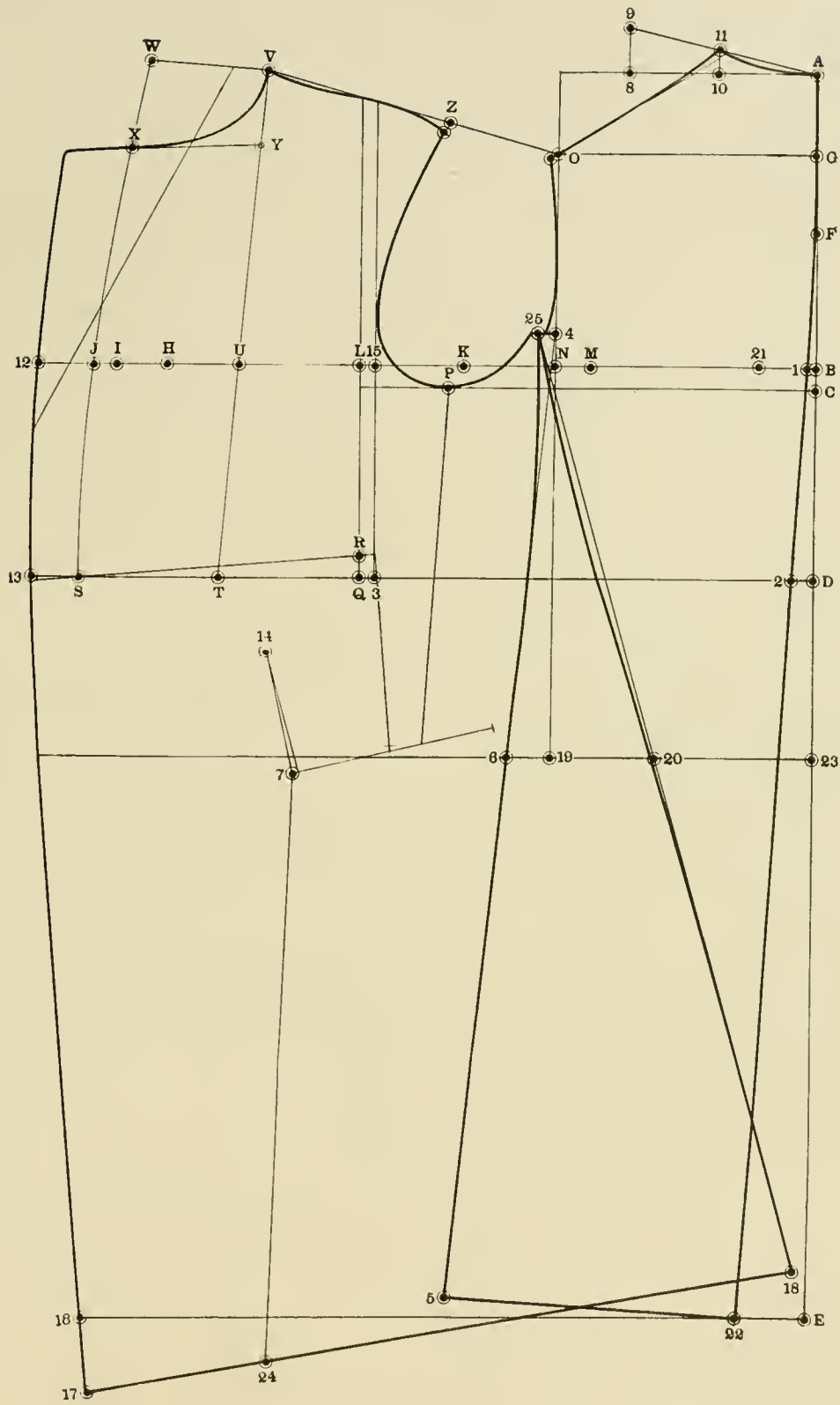

DIAGRAM 62

## DIAGRAM 63

## DOUBLE-BREADED ULSTER.

The measurements as taken over the waistcoat are as follows:

Scye depth .....	9 $\frac{3}{8}$ inches	Overshoulder .....	17 $\frac{5}{8}$ inches
Waist length .....	17 inches	Blade .....	13 inches
Full length .....	47 inches	Breast .....	38 inches
Strap .....	12 $\frac{1}{2}$ inches	Waist .....	34 inches

Square down and out from A.

From A to B is the scye depth plus  $\frac{1}{4}$  inch; B to C is  $\frac{3}{4}$  inch; A to D is the waist length plus  $\frac{3}{4}$  inch; A to E is full length; F is halfway between A and C; G is halfway between A and F; square out from G, B, C, D and E.

From D to 2 is  $\frac{3}{4}$  inch; draw a line from F through 2 down; this locates 22; from 1 to 3 is 1 $\frac{1}{2}$  inches; 3 to H is  $\frac{1}{2}$  breast; H to I is 1 $\frac{3}{4}$  inches; I to J is  $\frac{3}{4}$  inch; K is halfway between 3 and H; K to L is 3 $\frac{1}{2}$  inches; square down from L; apply the blade measure from 3 to L which is 13 inches and square up; from L to 15 is  $\frac{1}{2}$  inch; point M is halfway between 1 and 15; from M to N is 1 $\frac{1}{4}$  inches; square up and down from N; from N to P is 1 inch; from P to 4 is  $\frac{1}{2}$  inch.

From A to 8 is 6 $\frac{3}{8}$  inches; 8 to 9 is 1 $\frac{1}{2}$  inches; draw a line from A to 9; from A to 10 is  $\frac{1}{8}$  breast; square up from 10 to locate 11; draw a line from 11 to O; from 19 to 6 is 1 inch; draw a line from N through 6 down; this locates point 9; shape the back from A to 11, 11 to O, O to 4 and from 4 through 6 down to 9; 6 to 20 is 2 $\frac{1}{2}$  inches; draw a line from 1 through 20 down; hollow the side seam at 20 about  $\frac{3}{8}$  inch.

From Q to S is  $\frac{1}{2}$  waist; point T is halfway between Q and S; point U is halfway between L and I; draw a line from T through U up; from A to 11 and L to V is the strap measure plus  $\frac{3}{4}$  inch; draw a line from V to O; from V to Z is  $\frac{3}{8}$  inch less than 11 to O; shape the shoulder and armseye; square forwards from V by line T-U; from V to W is  $\frac{1}{8}$  breast plus  $\frac{1}{2}$  inch; draw a rounding line from W to J; from W to X is  $\frac{1}{8}$  breast; V to Y is  $\frac{1}{8}$  breast; draw a line from Y to X and shape the gorge.

From Q to R is  $\frac{3}{4}$  inch; draw a line from R through S; from S to 13 is 3 $\frac{3}{4}$  inches; J to 12 is the same; square down from 13 by line R-S; this locates point 16; from 16 to 17 is  $\frac{1}{8}$  breast; shape the front edge. Now add  $\frac{3}{4}$  inch as from 4 to 5 and 9 to 10 and reshape the backpart; from 4 to 18 is the same length as from 5 to 10; shape the bottom of forepart and finish.

## THE COLLAR.

Draw the crease line from 12 through 27 up; this coat is to button up high or to roll down to the second button; the collar is cut so as it will button easily in either case; from V to 21 is the same width as from A to 11 on the backpart; from 21 to 23 is 1 $\frac{1}{4}$  inches and from 23 to 24 is the same; shape the crease line from 23 through V to 27.

From V to 25 is  $\frac{3}{4}$  inch; place the square to points 23-25 and square out to 26; from 23 to 26 is the width of the collar desired; shape the collar and finish.

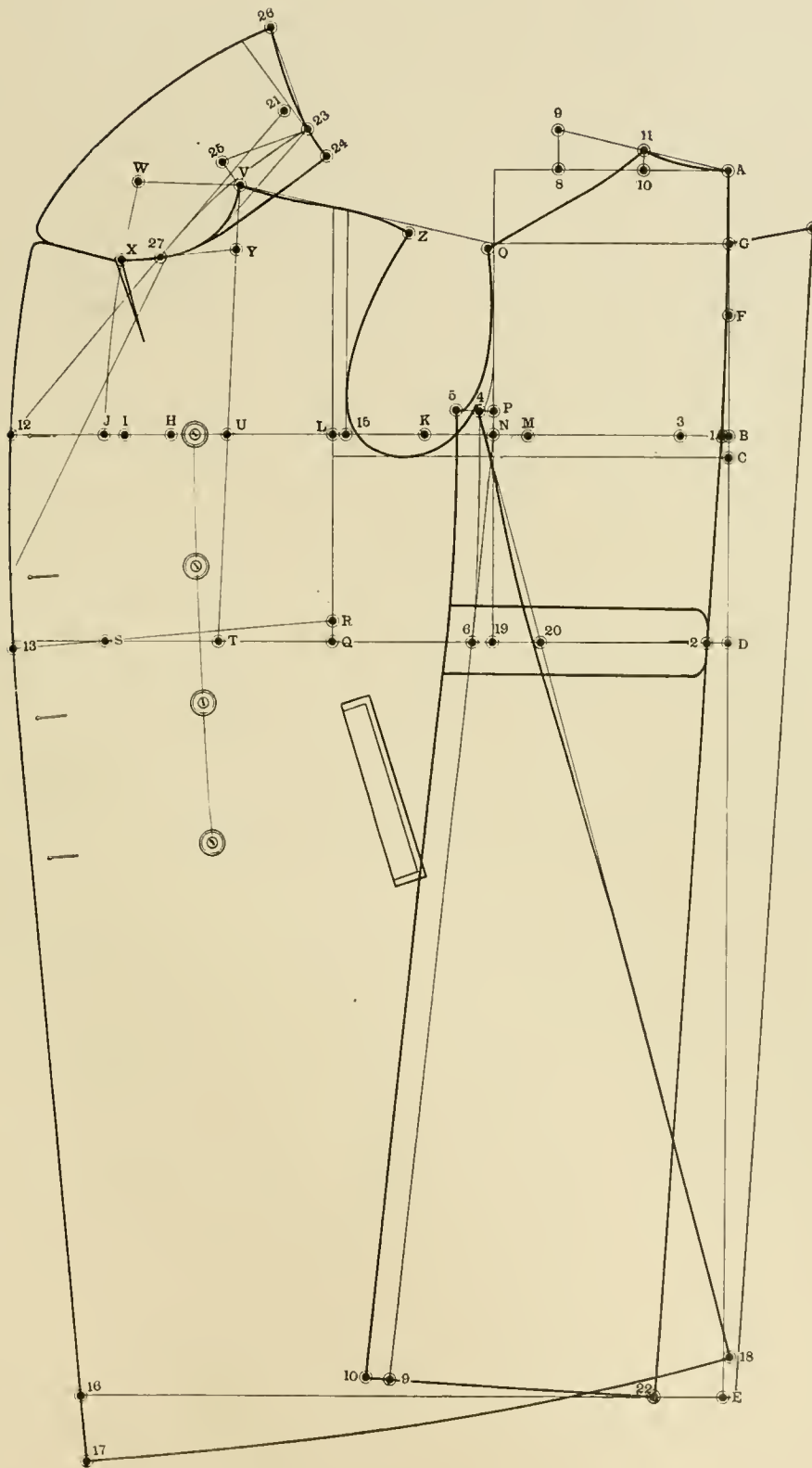

DIAGRAM 63

## DIAGRAM 64

## SINGLE-BREASTED BOX OVERCOAT.

The measurements as taken over the waistcoat are as follows:

Scye depth .....	9 inches	Overshoulder .....	17 inches
Waist length .....	16½ inches	Blade .....	12½ inches
Full length whatever style calls for.		Breast .....	36½ inches
Strap .....	12 inches	Waist .....	32 inches

Square down and out from A.

From A to B is scye depth plus  $\frac{1}{4}$  inch; B to C is  $\frac{3}{4}$  inch; A to D is waist length plus  $\frac{3}{4}$  inch; E is full length; F is halfway between A and C; G is halfway between A and F; square out from G, B, C, D and E.

From D to 2 is  $\frac{3}{4}$  inch; draw a straight line from F through 2 down; this locates 22; square forwards from 22 by that line; from 1 to 21 is  $1\frac{1}{2}$  inches; 21 to H is  $\frac{1}{2}$  breast; H to I is  $1\frac{1}{2}$  inches; I to J is  $\frac{3}{4}$  inch; K is halfway between 21 and H; K to L is  $3\frac{1}{2}$  inches; square down from L to locate Q; apply the blade measure from 21 to L which is  $12\frac{1}{2}$  inches and square up; L back to 15 is  $\frac{1}{2}$  inch; square up and down from 15; this locates 3.

Point M is halfway between 1 and 15; M to N is  $1\frac{1}{4}$  inches; square up from N to locate O; A to 8 is  $6\frac{3}{8}$  inches; 8 to 9 is  $1\frac{1}{2}$  inches; draw a line from A to 9; from A to 10 is  $\frac{1}{6}$  breast; square up from 10 to locate 11; draw a line from 11 to O and shape the back; point 4 is where the armhole crosses the breast line; square down from 4 to locate 19; 19 to 6 is  $1\frac{1}{2}$  inches; 6 to 20 is  $3\frac{1}{2}$  inches; draw lines from 4 through 6 to 7 and from 4 through 20 to 18.

From 3 to S is  $\frac{1}{2}$  waist; point T is halfway between Q and S; point U is halfway between L and 1; draw a line from T through U up; from A to 11 and L to V is the strap measure plus 1 inch; draw a line from V to O; V to Z is  $\frac{3}{8}$  inch less than 11 to O; shape the shoulder and armscye as shown; from 3 up to R is  $1\frac{1}{4}$  inches; from S to 13 is  $1\frac{1}{2}$  inches; J to 12 is the same; draw a line from R to 13 and square down; this locates point 16; from 16 to 17 is  $\frac{1}{8}$  breast; shape the front edge; square forwards from V by line T-U; V to W is  $\frac{1}{6}$  breast plus  $\frac{1}{2}$  inch; draw a rounding line from W to J.

From W to X is  $\frac{1}{6}$  breast; V to Y is  $\frac{1}{8}$  breast; draw a line from Y to X and shape the gorge; now add to the backpart from 4 to P,  $1\frac{1}{4}$  inches and from 7 to 5 the same and reshape the back as shown; from 4 to 18 is the same distance as from P to 5; shape the bottom of forepart and finish.

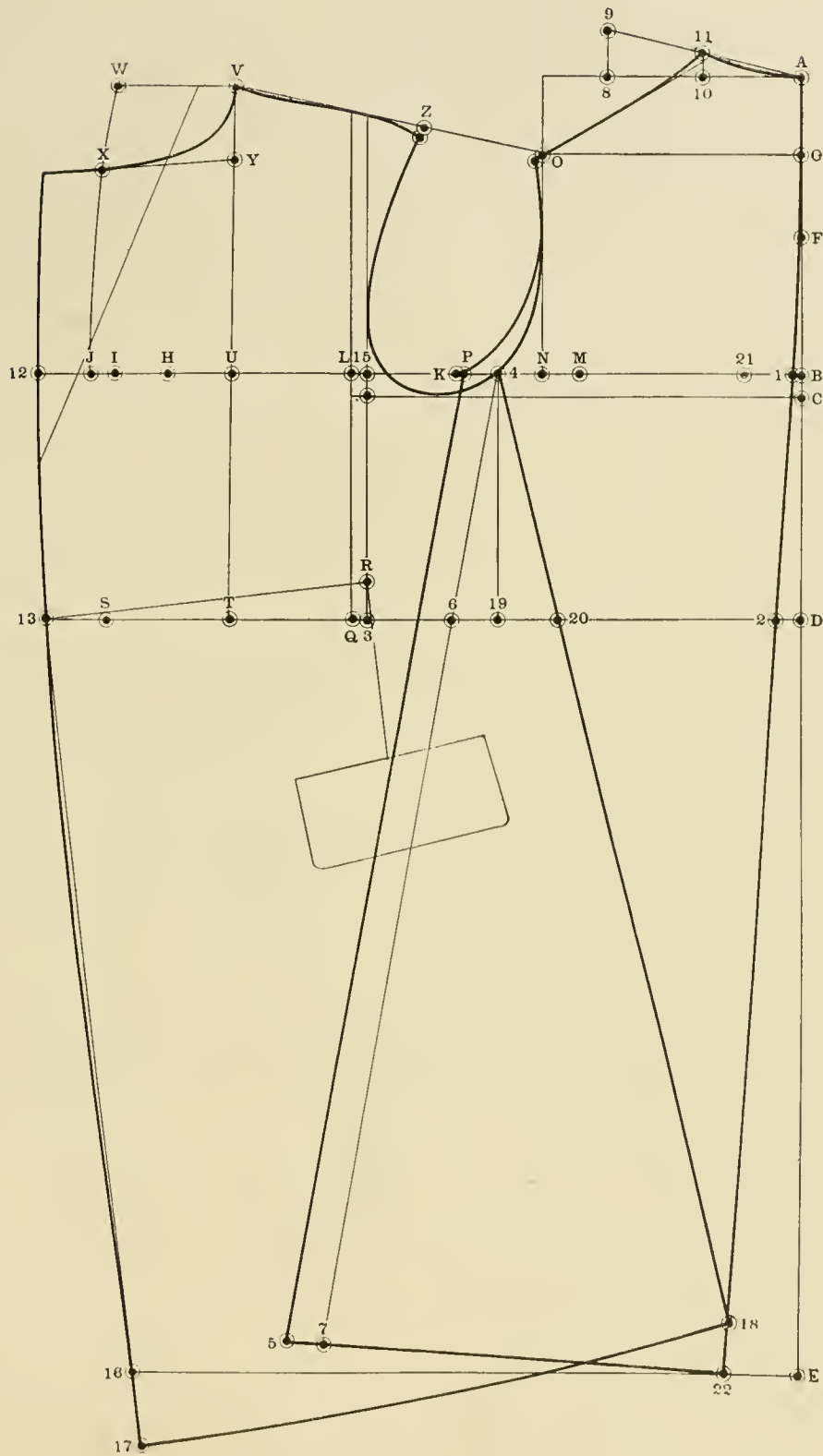

DIAGRAM 64

## DIAGRAM 65

## BOX OVERCOAT FOR A STOUT FIGURE.

The measurements as taken over the waistcoat are as follows:

Scye depth .....	9½ inches	Overshoulder .....	18¼ inches
Waist length .....	17 inches	Blade .....	13½ inches
Full length whatever style calls for.		Breast .....	40 inches
Strap .....	13 inches	Waist .....	40 inches

Square down and out from A.

From A to B is the scye depth plus ¼ inch; B to C is ¾ inch; A to D is waist length plus ¾ inch; E is full length; F is halfway between A and C; G is halfway between A and F; square out from G, B, C, D and E.

From D to 2 is ¾ inch; draw a line from F through 2 and shape the center seam; this locates 22; square forwards from 22 by that line; 1 to 21 is 1½ inches; 21 to H is ½ breast; H to I is 1½ inches; I to J is ¾ inch; K is halfway between 21 and H; K to L is 3½ inches; square down from L to locate Q; apply the blade measure from 21 to L which is 13½ inches and square up.

From L back to 15 is ½ inch; square up and down from 15; this locates point 3; point M is halfway between 1 and 15; M to N is 1¼ inches; square up from N; from A to 8 is 6¾ inches; 8 to 9 is 1½ inches; draw a line from A to 9; from A to 10 is ⅝ breast; square up from 10 to locate 11; draw a line from ¼ inch below 11 to O; shape the upper part of the back as from A to 11, 11 to O and O through 4.

Point 4 is where the armhole crosses the breast line; square down from 4; this locates 19; from 19 to 6 is 1½ inches; 6 to 20 is 3½ inches; draw line from 4 through 6 down; this locates 7; also draw a line from 4 through 20 down; from 3 to S is ½ waist; point T is halfway between Q and S; point U is halfway between L and I; draw a line from T through U up.

From A to 11 and L to V is the strap measure plus 1 inch; draw a line from V to O; from V to Z is ¾ inch less than the back shoulder width; shape the shoulder and armseye; square forwards from V by line T-U; V to W is ⅝ breast plus ¾ inch; draw a line from W to J; W to X is the depth of the gorge desired; V to Y is ⅝ breast; draw a line from Y to X and shape the gorge; J to 12 is 1¾ inches; S to 13 is the same; Q to R is 1¼ inches; square down from 13 by line R-S; this locates 16.

From 16 to 17 is ⅝ breast; from 4 to 14 is the same length as from 4 to 7; shape the bottom of forepart; now add to the back from 1 to P and 7 to 5 1¼ inches and reshape the back. In a coat of this kind it is not absolutely necessary to split the front for the sake of taking out the front fulness, but if so desired, it may be done as follows: split the forepart as from 28 to 23, 23 to 24 and from 24 to 26; overlap it the same way as shown on diagram 66, but in which case it is well to add as from 14 to 18 about as much as will be taken out between 26 and 27; this is done so as the drapery should not be lessened.



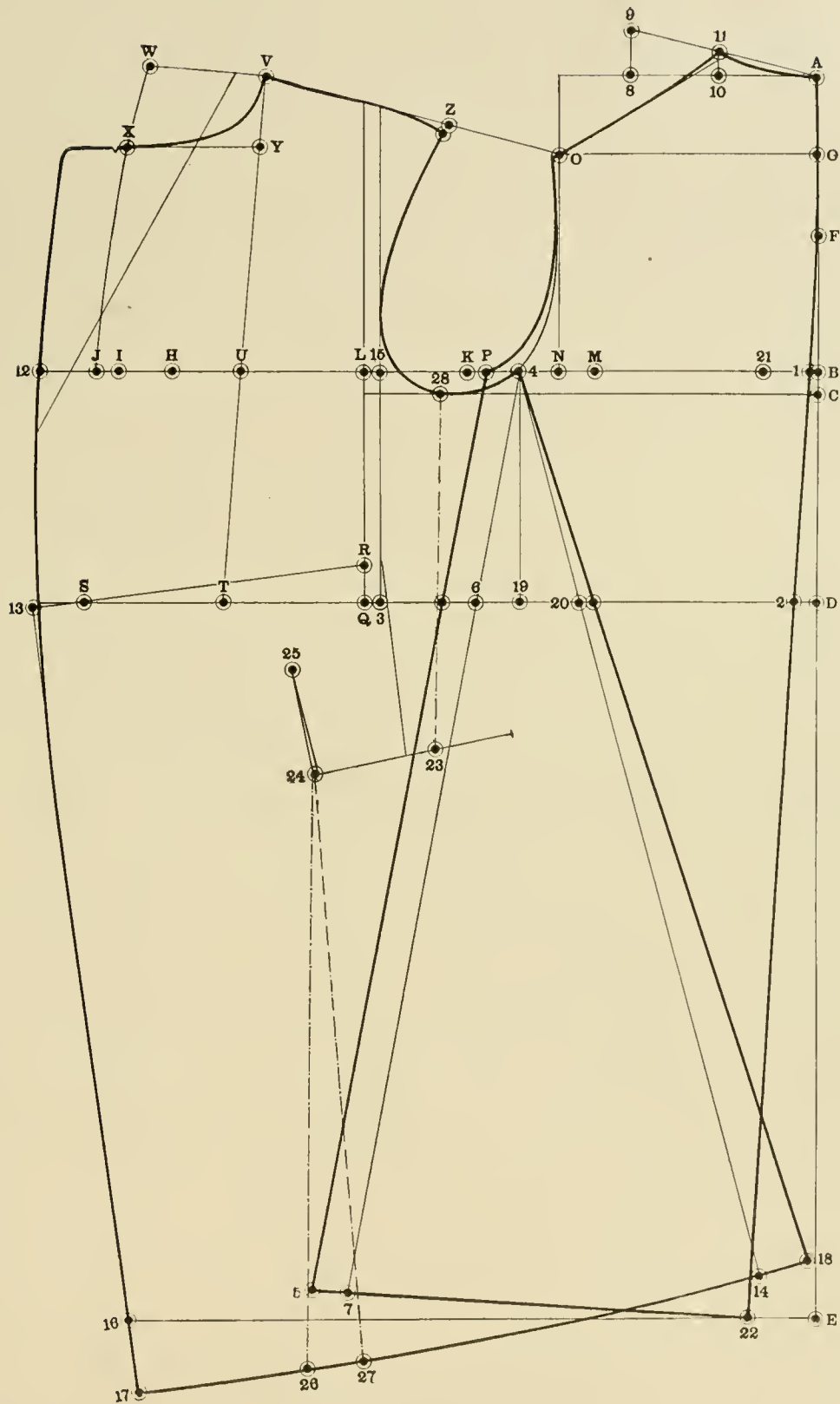

DIAGRAM 65

## DIAGRAM 66

After the forepart has been split as shown on diagram 65, place the two parts of the forepart together so that they should touch at D-E; open from A to B say about 1 or  $1\frac{1}{4}$  inches allowing it to overlap from G to H and reshape the bottom. Cut out a small V as at C so that when the two seams are taken out the lower edge of the pocket should not be fuller than the upper edge.

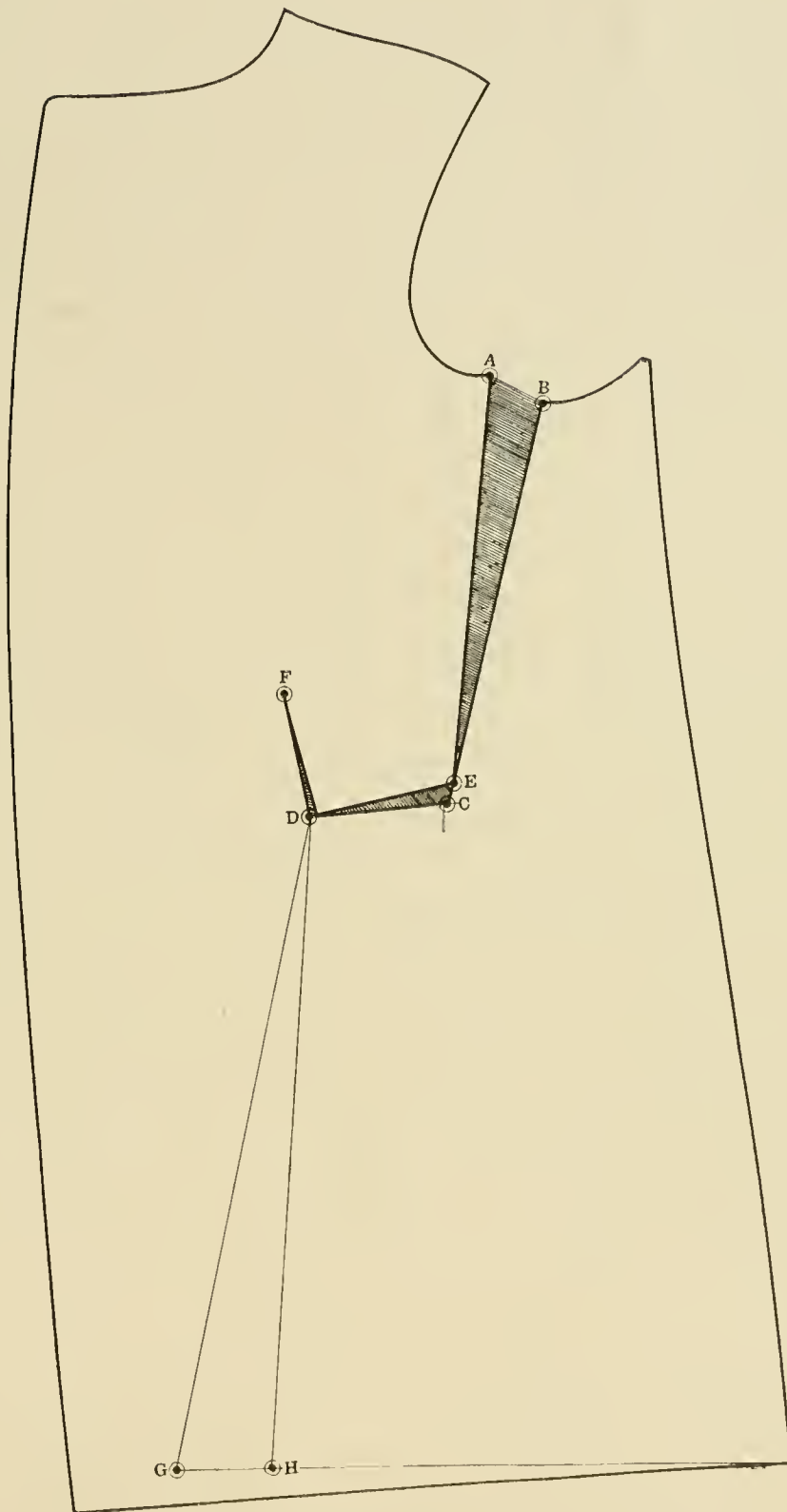

DIAGRAM 66

## DIAGRAM 67

This diagram is the same as diagram 65 with the exception that this is a Double-Breasted Overcoat, and the addition to the front edge should be made as follows: from 25 to 12 should be  $\frac{1}{2}$  of the button lap and from S to 13 the same.

Finish the coat in the same manner as shown on diagrams 65 and 66.

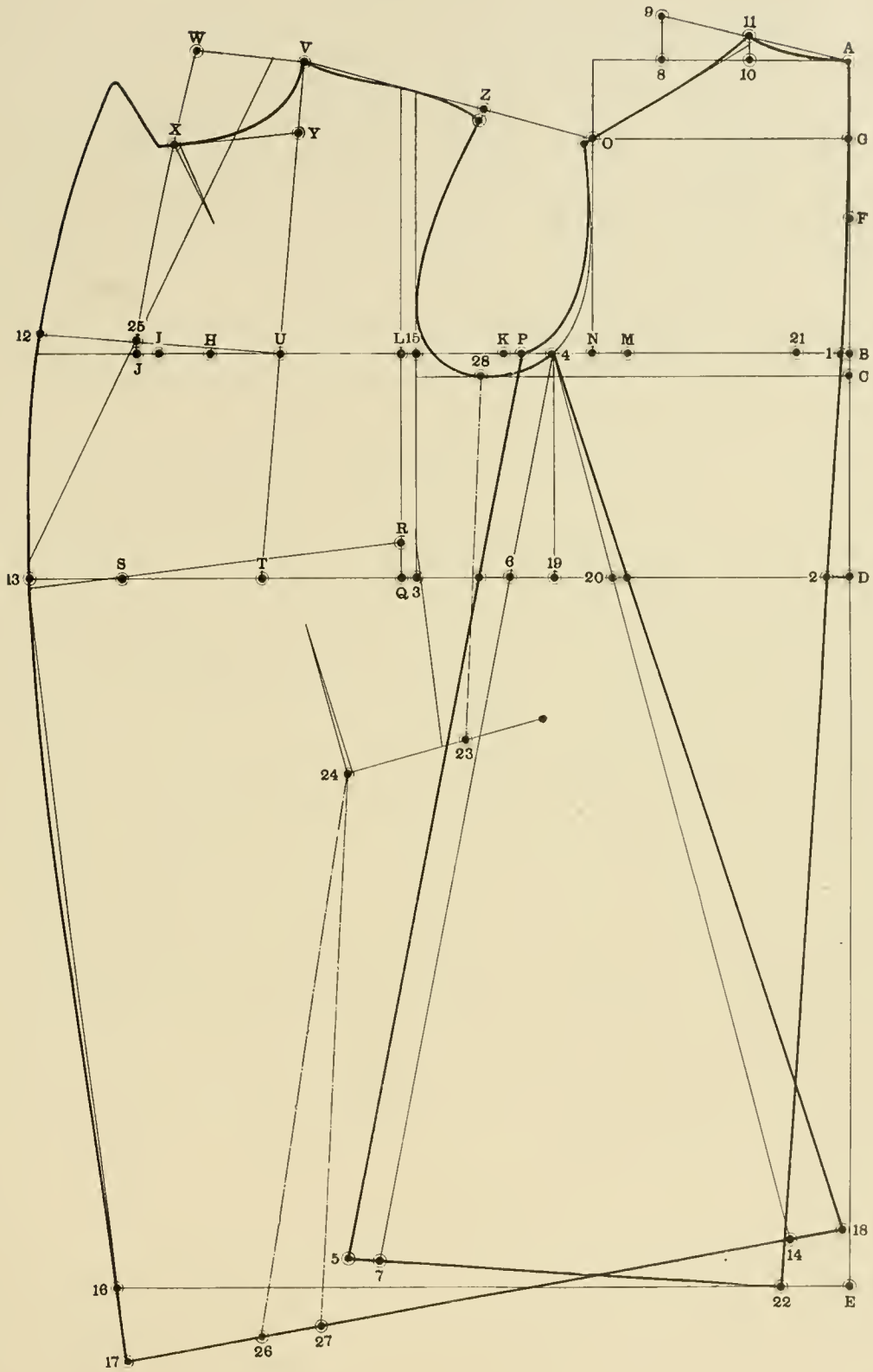

DIAGRAM 67

## DIAGRAM 68

## SINGLE-BREADED FROCK OVERCOAT.

The measurements as taken over the waistcoat are as follows:

Indentation .....	1½ inches	Strap .....	12½ inches
Seye depth .....	9¾ inches	Overshoulder .....	17⅝ inches
Natural waist length .....	16½ inches	Blade .....	13 inches
Fashionable waist length .....	18¼ inches	Breast .....	38 inches
Full length according to style.		Waist .....	34½ inches

Square down and out from A.

From A to B is the seye depth plus ¼ inch; B to 30 is ¾ inch; A to C is ½ inch more than the natural waist length; C to D is 1½ inches or may be 1¾ inches; E is full length; F is halfway between A and 30; G is halfway between A and F; square out from G, F, B, 30, C, D and E.

From C to R is ½ the indentation; draw a line from A through R to Q and square down; this locates H; from H to I is 1½ inches or may be made 1¾ inches; from I to J is ½ breast; J to K is 1½ inches; K to L is ¾ inch; L is halfway between I and J; from L to M is 3½ inches; square down from L to locate M; apply the blade measure from I to L which is 13 inches and square up; L back to 31 is ½ inch; point N is halfway between H and 31; N to O is 1¼ inches; A to 28 is the same distance as H to O; draw a line from O to 28.

From A to T is 6⅜ inches; T to U is 1½ inches; draw a line from A to U; from A to V is ⅓ breast; square up from V to locate W; draw a line from ¼ inch below W to P; from Q to S is ⅓ breast plus ¼ inch or may be made to style; square down from S and shape the back; from X to Y is 1¼ inches; square down from Y; 1 to 2 is ¾ inch; from O to 23 is ½ breast; point Z is halfway between the line squared down from 31 and Y; point 3 is ½ inch above the waist line; shape the sidebody.

From M to 4 is ½ of 31½ waist; square down from 4; this locates H; from H to 14 is ½ inch less than ⅓ breast; point 5 is halfway between M and 4; point 6 is halfway between L and J; draw a line from 5 through 6 up; from A to W and L to 7 is the strap measure plus ¾ inch; draw a line from 7 to P; from 7 to 23 is ⅜ inch less than W to P; shape the shoulder and armseye.

Square forwards from 7 by line 5-6; from 7 to 9 is ⅓ breast plus ½ inch; draw a line from 9 to 22; from 9 to 10 is ⅓ breast; 7 to 8 is ⅓ breast; draw a line from 8 to 10 and shape the gorge; from 4 back to 17 is 2¼ inches; from R to 29 is the same distance as from H to I; from Z to Y, X to 29 and 17 to 21 is the waist measure net; shape the side of forepart.

Place the square to line 14-4 and make a mark at 36; sweep from 14 forwards and backwards pivoting at 36 and shape the bottom of forepart; from 22 to 27 is 1¾ inches; 4 to 32 is the same; shape the front edge.

## THE SKIRT.

Draw a straight line from the front sweep to 16; this locates point 12; go up from 16 to 21, 1¼ inches more or less according to the amount of flare desired; draw a line from 12 to 24 and square down by that line to 25; from 24 to 25 is 9 inches; from 25 to 26 is 1½ inches; draw a line from 24 through 26 down; from 24 to 19 is ¼ inch more than S to 18; from 14 to 15 is the same distance as from 24 to 19; finish the skirt as shown, rounding it ⅝ inch at 26.

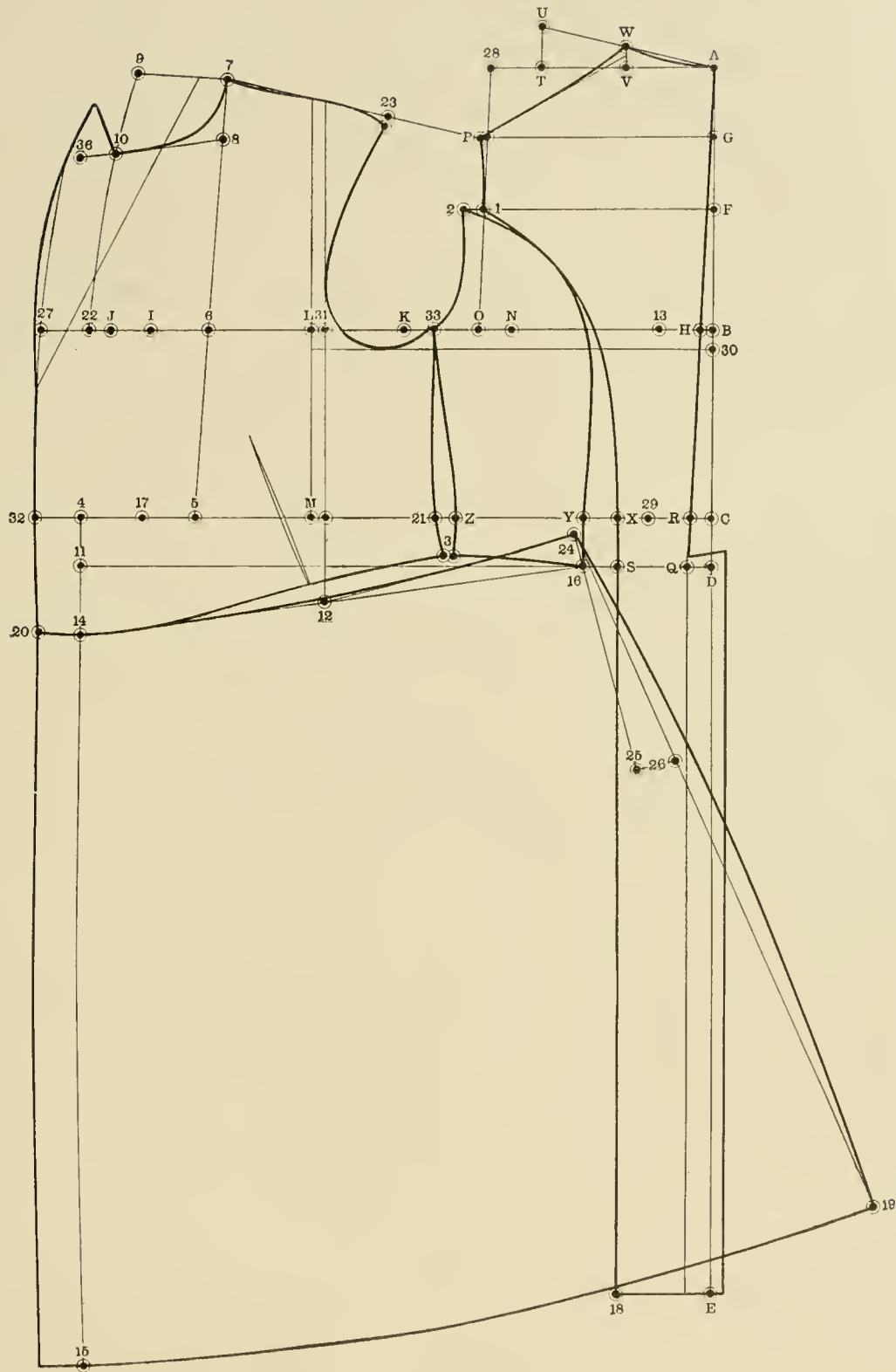

DIAGRAM 68

## DIAGRAM 69

## SINGLE-BREASTED FROCK OVERCOAT FOR A STOUT FIGURE.

The measurements as taken over the waistcoat are as follows:

Indentation .....	1½ inches	Strap .....	13½ inches
Scye depth .....	9¾ inches	Overshoulder .....	19 inches
Natural waist length .....	17 inches	Blade .....	14 inches
Fashionable waist length .....	18¾ inches	Breast .....	42 inches
Full length according to style.		Waist .....	42 inches

Square down and out from A.

From A to B is the scye depth plus ¼ inch; B to 30 is ¾ inch; A to C is natural waist length plus ½ inch; C to D is 1½ or 1¾ inches; E is full length; F is halfway between A and 30; G is halfway between A and F; square out from G, F, B, 30, C, D and E.

From C to R is ¾ inch; draw a line from A through R to Q; from H to 13 is 1½ inches; R to 29 is the same; from 13 to I is ½ breast; I to J is 1½ inches; J to 22 is ¾ inch; square up from 22; K is halfway between 13 and I; from K to L is 3½ inches; square down from L to locate M; apply the blade measure from 13 to L and square up; from L back to 31 is ½ inch; point N is halfway between H and 31; N to O is 1¼ inches.

From A to 28 is the same distance as from H to O; draw a line from O to 28; A to T is 6⅜ inches; T to U is 1½ inches; draw a line from A to U; A to V is ⅙ breast; square up from V to locate W; draw a line from ¼ inch below W to P; from Q to S is ⅙ breast plus ¼ inch; square down from S and shape the back; from X to Y is 1¼ inches; square down from Y; from 1 to 2 is ¾ inch; O to 33 is ⅓ breast; point Z is halfway between Y and 37; point 3 is ½ inch above the waistline; shape the sidebody.

## THE FOREPART.

From M to 4 is ½ waist; square down from 1; this locates 11; from 11 to 14 is ½ inch less than ⅙ breast; this being a coat for a stout figure, we go down from 14 to 34, ¾ inch; draw a line from 3 to 34; point 5 is halfway between M and I; point 6 is halfway between L and J; draw a line from 5 through 6 up; from A to W and L to 7 is the strap measure plus ¾ inch; draw a line from 7 to P; 7 to 23 is ⅜ inch less than W to P; shape the shoulder and armseye.

Square forwards from 7 by line 5-6; 7 to 9 is ⅙ breast plus ¼ inch; square forwards from 6 by line 5-6; this locates 35; draw a line from 9 to 35; from 9 to 10 is the depth of the gorge desired; 7 to 8 is ⅙ breast; draw a line from 8 to 10 and shape the gorge; from 4 back to 17 is 1¾ inches; from Z to Y, X to 29 and 17 to 21 is the waist measure net; shape the side of forepart.

From 35 to 27 is 1¾ inches; from 4 to 32 is the same; shape the front edge; place the straight edge to line 14-4 and make a mark at 36; draw a straight line from 16 to 14; cut out a small V where the two lines cross; from 11 back to 38 is 2½ inches; sweep from 38 forwards pivoting at 36; hollow the forepart slightly between 3 and the V and shape the bottom of forepart.

## THE SKIRT.

From 16 up to 24 is 1¼ inches; draw a line from 12 to 24 and by that line square down to 25; from 24 to 25 is 9 inches; from 25 to 26 is 1½ inches; draw a line from 24 through 26 down; from 24 to 19 is ¼ inch more than from S to 18; from 14 to 15 is the same distance as 21 to 19; square down from 20 by the waistline; finish the skirt as shown rounding it ⅝ inch at 26.



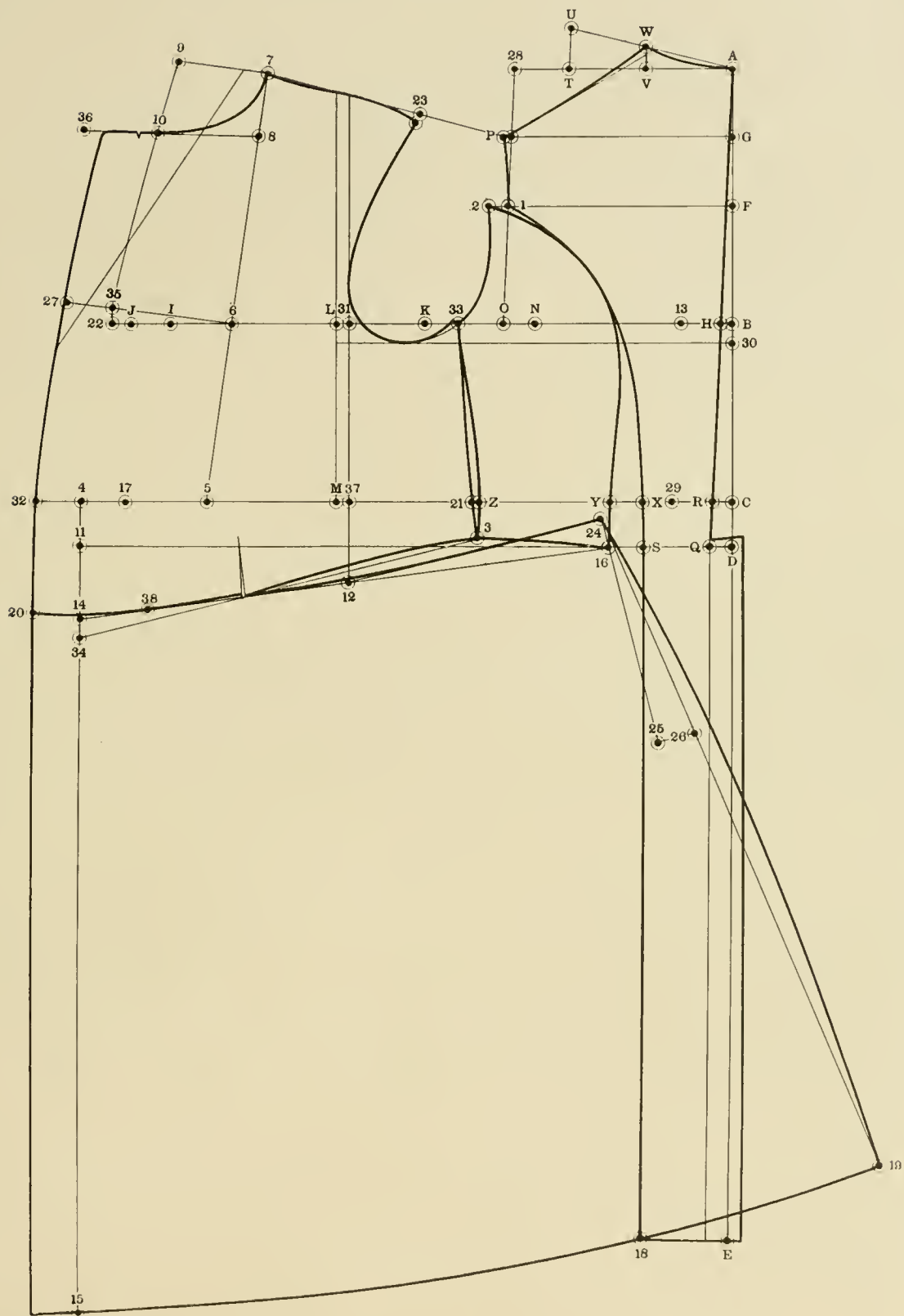

DIAGRAM 69

## DIAGRAM 70

## SINGLE-BREASTED PADDOCK OVERCOAT.

The measurements as taken over the waistcoat are as follows:

Indentation .....	1½ inches	Strap .....	12¾ inches
Scye depth .....	9½ inches	Overshoulder .....	18 inches
Natural waist length .....	16¾ inches	Blade .....	13¼ inches
Fashionable waist length .....	18½ inches	Breast .....	39 inches
Full length according to style.		Waist .....	35½ inches

Square down and out from A.

From A to B is the scye depth plus ¼ inch; B to 19 is ¾ inch; A to C is natural waist length plus ½ inch; C to D is 1½ or 1¾ inches; A to E is full length; F is halfway between A and 19; G is halfway between A and F; square out from G, F, B, 19, C, D and E.

From C to R is ¾ inch; draw a line from A through R to Q and square down; from H to 32 is 1½ inches; R to 33 is the same; from 32 to I is ½ breast; I to J is 1½ inches; J to 14 is ¾ inch; K is halfway between 32 and I; K to L is 3½ inches; square down from L to locate M; apply the blade measure from 32 to L which is 13¼ inches and square up; L back to 15 is ½ inch; square up and down from 15; N is halfway between H and 15; from N to O is 1¼ inches.

From A to 24 is the same distance as from H to O; draw a line from O to 24; from A to T is 6⅜ inches; T to U is 1½ inches; draw a line from A to U; from A to V is ⅓ breast; square up from V to locate W; draw a line from ¼ inch below W to P; Q to S is ⅓ breast plus ¼ inch or make the distance to suit the style; square down from S and shape the back; from X to Y is 1¼ inches; square down from Y; from 1 to 2 is ¾ inch; O to Z is ⅓ breast; point 22 is halfway between 29 and Y; point 3 is ½ inch above the waistline; shape the sidebody.

## THE FOREPART.

From M to 4 is ½ waist; square down from 4 to locate 11; from 11 to 13 is ½ inch less than ⅓ breast; point 5 is halfway between M and 1; point 6 is halfway between L and J; draw a line from 5 through 6 up; from A to W and L to 7 is the strap measure plus ¾ inch; draw a line from 7 to P; 7 to 34 is ⅜ inch less than W to P; shape the shoulder and armscye.

Square forwards from 7 by line 5-6; from 7 to 9 is ⅓ breast plus ½ inch; draw a rounding line from 9 to 14; from 9 to 10 is ⅓ breast or to suit the style; 7 to 8 is ⅓ breast; draw a line from 8 to 10 and shape the gorge; 11 to 30 is 1¾ inches; 4 to 31 is the same; 4 back to 27 is 2¼ inches; from 22 to Y, X to 33 and 27 to 21 is the waist measure net; shape the side of forepart.

Draw a line from 13 through 3 to 21; square down from 21; from 24 to 25 is 9 inches; 25 to 26 is 1½ inches; draw a line from 24 through 26 down; from 24 to 18 is ¼ inch more than from S to 17; from 13 to 28 is ½ inch less than 24 to 18; shape the front edge and finish the skirt rounding it ⅝ inch at 26. This skirt cuts open to point 16 and from there a fish is taken out; the front of the coat and skirt are left in one piece.

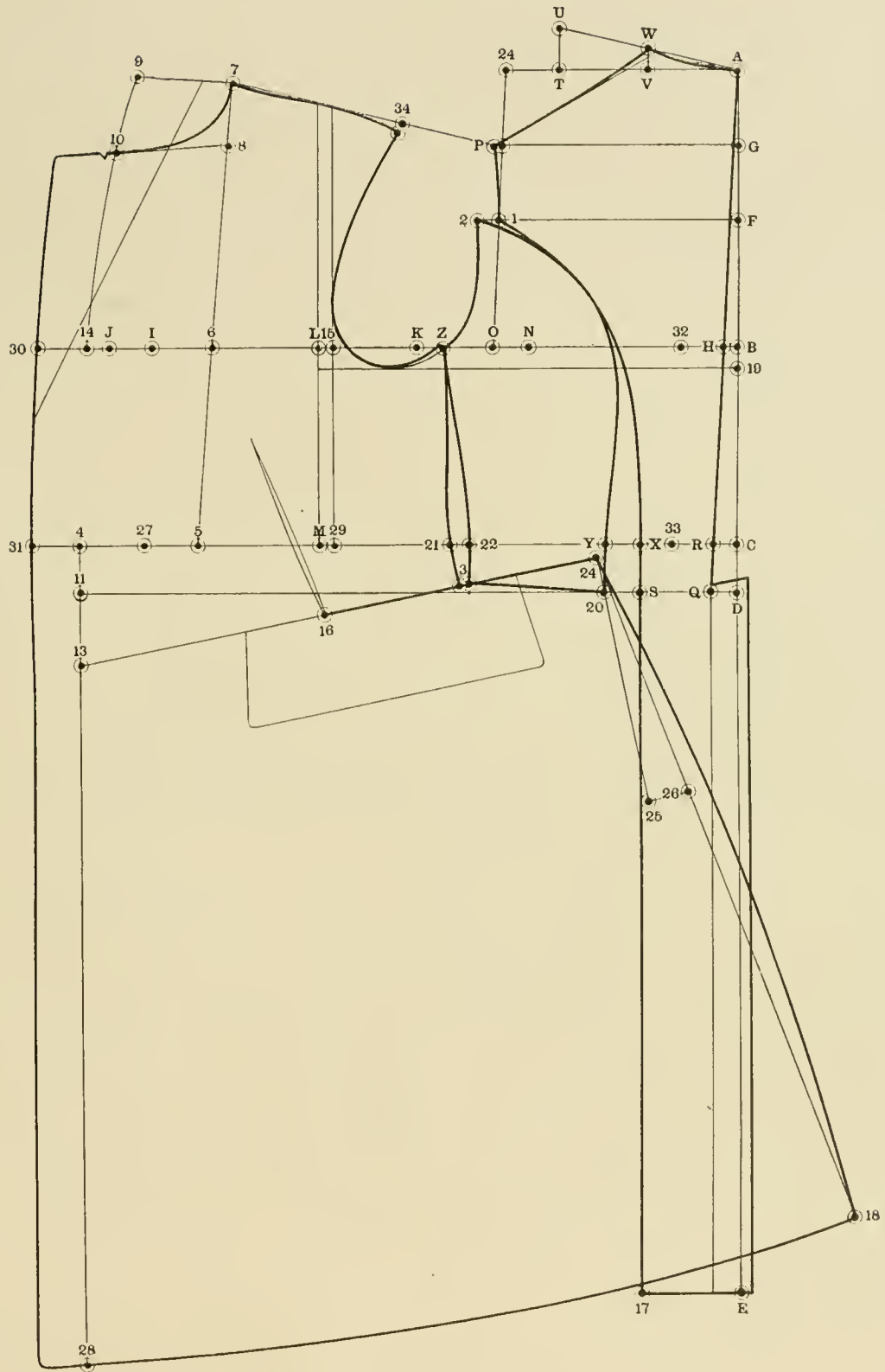

DIAGRAM 70

## DIAGRAM 71

## DOUBLE-BREASTED PALETOT.

The measurements as taken over the waistcoat are as follows:

Indentation .....	1½ inches	Strap .....	12 inches
Scye depth .....	9 inches	Overshoulder .....	17 inches
Natural waist length .....	16½ inches	Blade .....	12½ inches
Fashionable waist length .....	18¼ inches	Breast .....	36 inches
Full length to suit style.		Waist .....	32 inches

Square down and out from A.

From A to B is the scye depth plus ¼ inch; B to 30 is ¾ inch; A to C is natural waist length plus ¾ inch; C to D is 1¾ inches; A to E is full length; F is halfway between A and 30; G is halfway between A and F; square out from G, F, B, 30, C, D and E.

From C to R is ½ indentation; shape the center of back from F through R to Q and square down; from H to 13 is 1½ inches; R to 29 is the same; from 13 to I is ½ breast; I to J is 1¾ inches; J to 22 is ¾ inch; K is halfway between 13 and I; K to L is 3½ inches; square down from L to locate M; apply the blade measure from 13 to L which is 12½ inches and square up; from L back to 31 is ½ inch; square up from 31.

Point N is halfway between 11 and 31; from N to O is 1¼ inches; from A to 28 is the same distance as 11 to O; draw a line from O to 28; from A to T is 6¾ inches; T to U is 1½ inches; draw a line from A to U; A to V is ¾ breast; square up from V to locate W; draw a line from ¼ inch below W to P; from Q to S is 3½ inches; 24 to 18 is 5 inches; draw a line from S to 18 and shape the back.

From X to Y is 1 inch; square down from Y; this locates point 16; from Y to 25 is 9 inches; 25 to 26 is 1½ inches; draw a line from 16 through 26; from 16 to 19 is the same distance as from S to 18; from 1 to 2 is ¾ inch; square down from K; from M to 4 is ½ waist; point 5 is halfway between M and 4; point 6 is halfway between L and J; draw a line from 5 through 6 up; from A to W and L to 7 is the strap measure plus ¾ inch; draw a line from 7 to P; from 7 to 23 is ¾ inch less than W to P; shape the shoulder and armseye; square forwards from 7 by line 5-6; from 7 to 9 is ¾ breast plus ½ inch; draw a rounding line from 9 to 22.

From 9 to 10 is ¾ breast; 7 to 8 is ¼ breast; draw a line from 8 to 10 and shape the gorge; 22 to 27 is 3½ inches; 4 to 32 is the same; M to 20 is ¾ inch; draw a line from 20 to 32 and square down from 32; this locates 4; from 4 to 5 is ¼ breast; from 4 back to 17 is 2½ inches; apply the waist measure from X to 29 and 17 to Y and suppress the balance between Z and 21; add ⅝ inch round at 26.

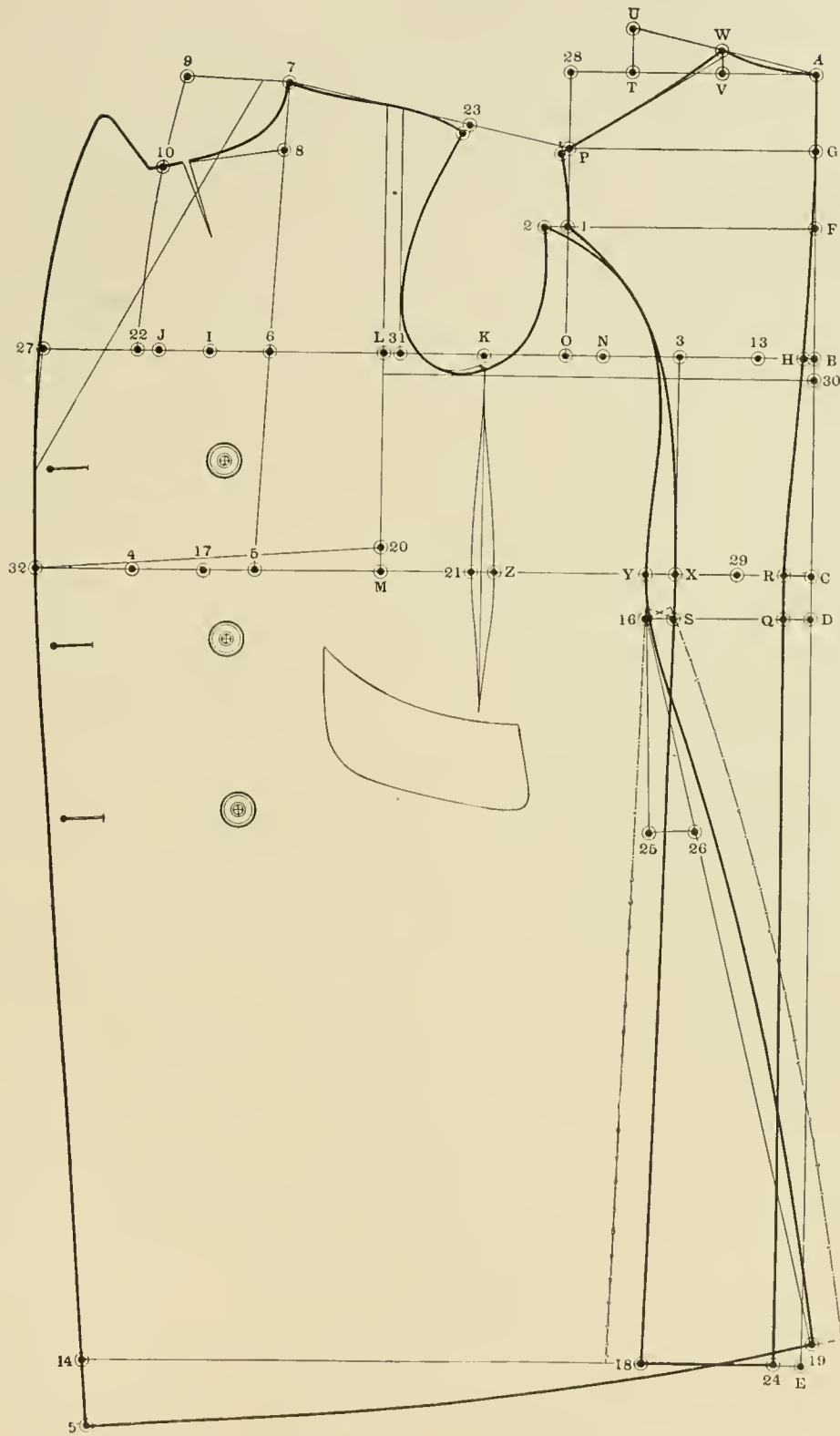

DIAGRAM 71

## DIAGRAM 72

## DOUBLE-BREADED FROCK OVERCOAT

The measurements as taken over the waistcoat are as follows:

Indentation .....	1½ inches	Strap .....	12½ inches
Scye depth .....	9¾ inches	Overshoulder .....	17½ inches
Natural waist length .....	16½ inches	Blade .....	13 inches
Fashionable waist length .....	18¼ inches	Breast .....	38 inches
Full length according to style		Waist .....	34½ inches

Square down and out from A.

From A to B is the scye depth plus ¼ inch; B to 30 is ¾ inch; A to C is natural waist length plus ½ inch; C to D is 1¾ inches; A to E is full length; F is halfway between A and 30; G is halfway between A and F; square out from G, F, B, 30, C, D and E.

From C to R is ½ indentation; draw a straight line from A through R to Q and square down; from H to 13 is 1½ inches; R to 29 is the same; 13 to I is ½ breast; I to J is 1½ inches; J to 22 is 1 inch; K is halfway between 13 and I; K to L is 3½ inches; square down from L to locate M; apply the blade measure from 13 to L which is 13 inches and square up; L back to 31 is ½ inch; square up and down from 31; point N is halfway between H and 31; N to O is 1¼ inches.

From A to 28 is the same distance as H to O; draw a line from O to 28; A to T is 6¾ inches; T to U is 1½ inches; draw a line from A to U; from A to V is ½ breast; square up from V to locate W; draw a line from ¼ inch below W to P; from Q to S is ⅛ breast plus ¼ inch or to style; square down from S and shape the back.

From X to Y is 1¼ inches; square down from Y; from 1 to 2 is ¾ inch; O to 33 is ⅛ breast; point Z is halfway between the line squared down from 31 and Y; point 3 is ½ inch above the waistline; shape the sidebody.

## THE FOREPART.

From M to 4 is ½ waist; square down from 4; from 11 to 14 is ½ inch less than ⅝ breast; point 5 is halfway between M and 4; point 6 is halfway between L and J; draw a line from 5 through 6 up; A to W and L to 7 is the strap measure plus ¾ inch; draw a line from 7 to P; 7 to 23 is ⅜ inch less than the back shoulder width; shape the shoulder and armseye.

Square forwards from 7 by line 5-6; 7 to 9 is ⅝ breast plus ¾ inch; add ¼ inch for seam in front of 4 and shape the front from 9 through 22 down to 11; from 9 to 10 is ⅝ breast; 7 to 8 is ⅛ breast; draw a line from 8 to 10 and shape the gorge; 4 back to 17 is 2¼ inches; Z to Y, X to 29 and 17 to 21 is the waist measure net.

## THE REVER.

Draw a straight line at 14-4 up to 36; sweep from 10 to 36 pivoting at 14; sweep from 14 forwards to 20 and backwards pivoting at 36; shape the bottom of forepart, including the rever. Make the width of the rever according to style.

## THE SKIRT.

Draw a straight line from 16 into the front sweep; this locates 12; from 16 to 24 is 1¼ inches; draw a line from 12 to 24 and square down; from 24 to 25 is 9 inches; 25 to 26 is 1½ inches; draw a line from 24 through 26 down; 24 to 19 is ¼ inch more than S to 18; 14 to 15 is the same distance as from 24 to 19; square down from 20 by the waistline; finish the skirt rounding it ⅝ inch at 26.

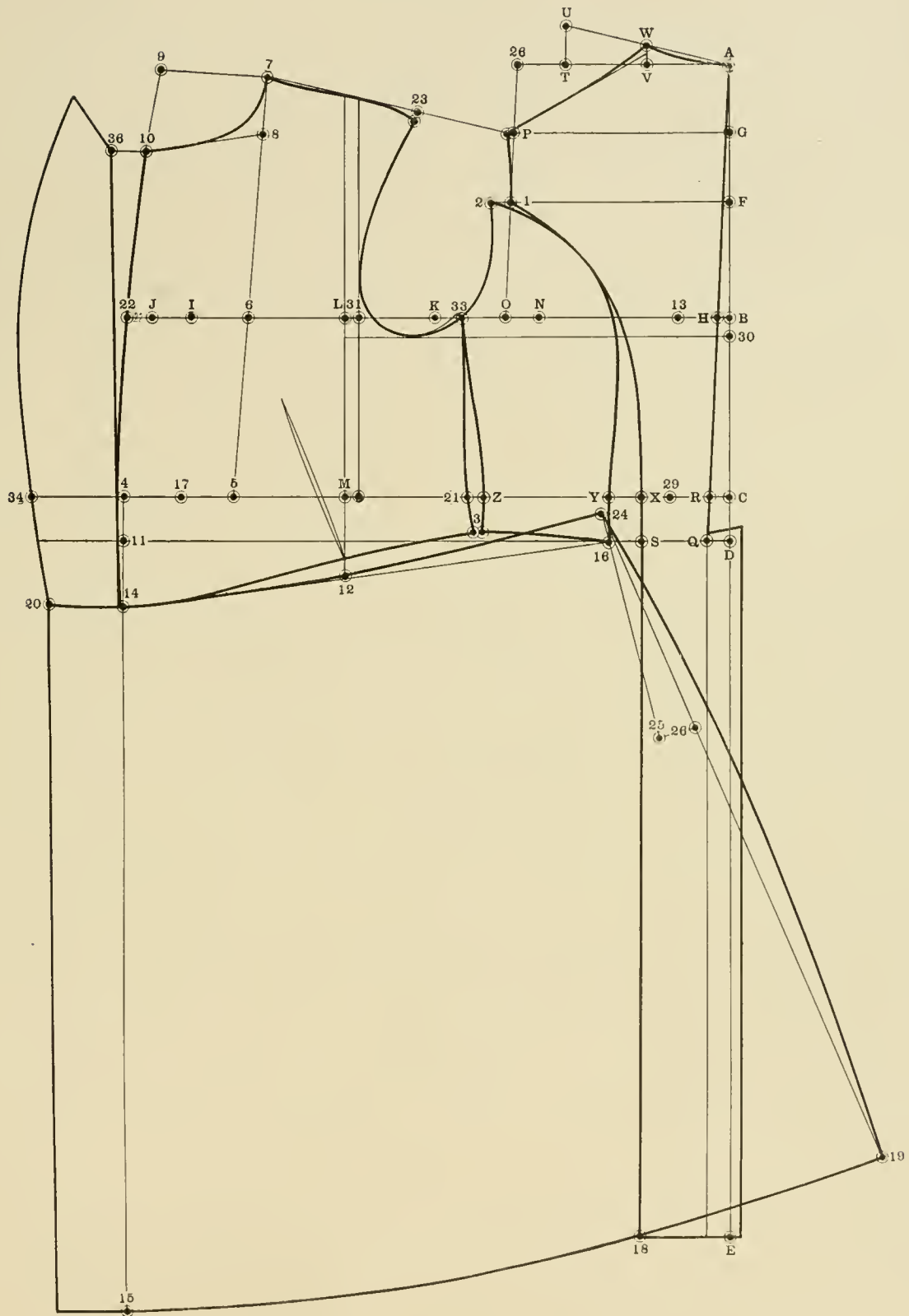

DIAGRAM 72

## DIAGRAM 73

## DOUBLE-BREADED FROCK OVERCOAT FOR A CORPULENT FIGURE.

The measurements as taken over the waistcoat are as follows:

Scye depth .....	9 $\frac{3}{4}$ inches	Overshoulder .....	19 inches
Natural waist length .....	17 inches	Blade .....	14 inches
Fashionable waist length .....	18 $\frac{3}{4}$ inches	Breast .....	42 inches
Full length according to style.		Waist .....	44 inches
Strap .....	13 $\frac{1}{2}$ inches		

Square down and out from A.

From A to B is the scye depth plus  $\frac{1}{4}$  inch; B to 30 is  $\frac{3}{4}$  inch; A to C is natural waist length plus  $\frac{1}{2}$  inch; C to D is 13 $\frac{3}{4}$  inches; A to E is full length; F is halfway between A and 30; G is halfway between A and F; square out from G, F, B, 30, C, D and E.

From C to R is  $\frac{3}{4}$  inch; draw a line from A through R to Q and square down; from H to 13 is 1 $\frac{1}{2}$  inches; R to 29 is the same; 13 to I is  $\frac{1}{2}$  breast; I to J is 1 $\frac{1}{2}$  inches; J to 22 is 1 inch; square up from 22; K is halfway between H and I; from K to L is 3 $\frac{1}{2}$  inches; square down from L to locate M; apply the blade measure from 13 to L which is 14 inches and square up; L back to 31 is  $\frac{1}{2}$  inch; square up and down from 31; N is halfway between H and 31.

From N to O is 1 $\frac{1}{4}$  inches; from A to 28 is the same distance as H to O; draw a line from O to 28; from A to T is 6 $\frac{3}{8}$  inches; T to U is 1 $\frac{1}{2}$  inches; draw a line from A to U; A to V is  $\frac{1}{8}$  breast; square up from V to locate W; draw a line from  $\frac{1}{4}$  inch below W to P; from Q to S is  $\frac{1}{8}$  breast plus  $\frac{1}{4}$  inch; square down from S and shape the back; from M to 4 is  $\frac{1}{2}$  waist; square down from 4; this locates 11.

From 11 to 14 is  $\frac{1}{2}$  inch less than  $\frac{1}{8}$  breast; 11 to 34 is  $\frac{3}{4}$  inch; from 4 back to 17 is 13 $\frac{1}{4}$  inches; X to 29 and 17 to Y is the waist measure net; square down from Y; from 1 to 2 is  $\frac{3}{4}$  inch; O to 33 is  $\frac{1}{2}$  breast; point Z is halfway between Y and 40; point 3 is  $\frac{1}{2}$  inch above the waistline; shape the sidebody, also the side of the forepart, overlapping it about  $\frac{3}{8}$  inch at 3; point 5 is halfway between M and 4; point 6 is halfway between L and J; draw a line from 5 through 6 up.

From A to W and L to 7 is the strap measure plus  $\frac{3}{4}$  inch; draw a line from 7 to P; from 7 to 23 is  $\frac{3}{8}$  inch less than the back shoulder width; shape the shoulder and armseye; square forwards from 7 by line 5-6; from 7 to 9 is  $\frac{1}{8}$  breast plus  $\frac{3}{4}$  inch; square out from 6 by line 5-6; this locates 35; add  $\frac{1}{4}$  inch for seam in front of 4 and shape the front edge from 9 through 35 down to 37.

Draw a line from 3 to 34; place the square to point 16-11 and draw a straight line across; 39 is where the two lines cross; cut out a small V at 39; shape the bottom of forepart, hollowing it slightly between 3 and 39.

## THE REVER

Draw a straight line from 37 up to 36; sweep from 10 to 36 pivoting at 37; from 14 back to 38 is 2 $\frac{1}{2}$  inches; sweep from 38 forwards to 20 pivoting at 36 and shape the bottom of forepart.

## THE SKIRT.

Point 12 has been located by drawing the line from 16 to 11; from 16 to 24 is 1 $\frac{1}{4}$  inches; draw a line from 12 to 24 and square down; 24 to 25 is 9 inches; 25 to 26 is 1 $\frac{1}{2}$  inches; draw a line from 24 through 26 down; from 24 to 19 is  $\frac{1}{4}$  inch more than from S to 18; 37 to 15 is the same distance as 24 to 19; square down from 20 by the waistline; finish the rever to style and round the skirt  $\frac{5}{8}$  inch at 26.



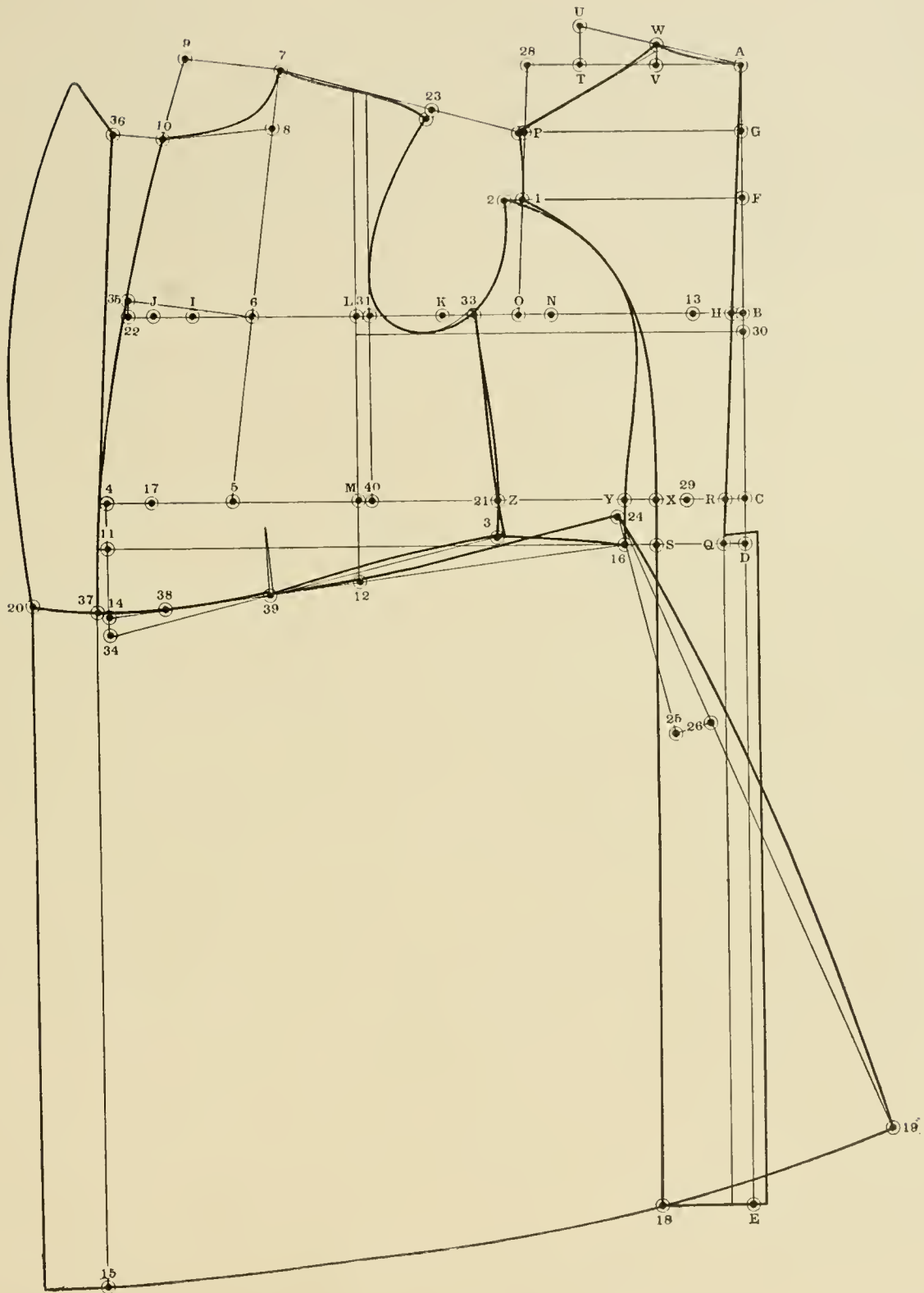

DIAGRAM 73

## DIAGRAM 74

## SHELL FOR FUR COAT.

The measurements as taken over the waistcoat are as follows:

Scye depth .....	9 inches	Overshoulder .....	17 inches
Waist length .....	16½ inches	Blade .....	12½ inches
Full length .....	48 inches	Breast .....	36 inches

(or whatever the style calls for).

Strap .....	12 inches	Waist .....	32 inches
-------------	-----------	-------------	-----------

This coat is to be increased two inches over the breast, waist and seat; also add  $\frac{3}{8}$  inch to the scye depth,  $\frac{1}{2}$  inch to the strap,  $\frac{3}{8}$  inch to the overshoulder and  $\frac{1}{2}$  inch to the blade. This makes the measurements as follows:

Scye depth .....	9¾ inches	Blade .....	13 inches
Strap .....	12½ inches	Breast .....	38 inches
Overshoulder .....	17¾ inches	Waist .....	34 inches

Square down and out from A.

From A to B is the scye depth plus  $\frac{1}{4}$  inch, in this case 9¾ inches; B to 18 is  $\frac{3}{4}$  inch; from A to C is the waist length plus  $\frac{3}{4}$  inch; C to D is 6 inches; A to E is full length; F is halfway between A and 18; G is halfway between A and F; square out from G, B, 18, C, D and E.

From C to 2 is  $\frac{3}{4}$  inch; draw a line from F to 2 and square down; this locates 1; from 1 to 3 is 1½ inches; 3 to H is  $\frac{1}{2}$  of 38 breast; H to I is 1¾ inches; I to J is  $\frac{3}{4}$  inch; K is halfway between 3 and H; K to L is 3½ inches; square down from L to locate Q; apply the blade measure plus an extra  $\frac{1}{2}$  inch from 3 to L, in this case 13 inches and square up; L back to 15 is  $\frac{1}{2}$  inch; M is halfway between 1 and 15; M to N is 1¼ inches; square up and down from N; this locates point 6; from 6 to 19 is 1 inch; 6 to 20 is 3½ inches; draw a line from N through 19 down; this locates 7; from N to P is 1 inch; P to 5 is  $\frac{1}{2}$  inch.

From A to 8 is 6¾ inches; 8 to 9 is 1½ inches; draw a line from A to 9; A to 10 is  $\frac{1}{8}$  of 38 breast; square up from 10 to locate 11; draw a line from 11 to O and shape the back.

## THE FOREPART.

Draw a straight line from 5 through 20 down; hollow the side seam at the waist about  $\frac{1}{4}$  inch; from 5 to 21 is the same length as from P to 7; from Q to S is  $\frac{1}{2}$  of 34 waist; point T is halfway between Q and S; point U is halfway between L and I; draw a line from T through U up; from A to 11 and L to V is the strap measure plus  $\frac{3}{4}$  inch, in this case 13¾ inches; draw a line from V to O; from V to Z is  $\frac{3}{8}$  inch less than 11 to O; shape the shoulder and armscye.

Square forwards from V by line T-U; from V to 4 is  $\frac{1}{8}$  breast plus  $\frac{3}{4}$  inch; draw a rounding line from 4 to S; from V to Y is  $\frac{1}{8}$  breast; make the distance from 4 down to the gorge  $\frac{1}{8}$  breast and shape the gorge; from J to 12 is 3½ inches; S to 13 is the same; from Q to R is 1 inch; square down from 13 by line R-13; this locates point 16; from 16 to 17 is  $\frac{1}{8}$  of 38 breast; shape the front edge and bottom of forepart.

## THE COLLAR.

The backpart:—Square up from 11 by line A-9 and square up from A by the same line; from A to 34 is 1¼ inches; 11 to 23 is the same; draw a line from 34 to 23; from 23 to X is 1¼ inches; 34 to W is the same; from 34 to 25 is the width of the collar desired plus  $\frac{1}{2}$  inch which is to be shaped off later on; 23 to 24 is the same; shape the backpart of the collar as shown.

The front part of the collar:—From 29 to 28 is 1¼ inches; draw a line through 28 for the break of lapel; this locates point 30; from 27 to 26 is 1¼ inches; place the square to line 28-31 and square up until the right angle touches at 14; square back from 31; this locates 32; shape the collar stand from 26 through 30 to 32; from 27 to 33 is the same distance as from 23 to 24 on the backpart of the collar; shape the collar from 33 through 32 into the front break line.

Now cut out the two parts of the collar and place them together, point 23 to 27 and point 24 to 33, and reshape the collar.

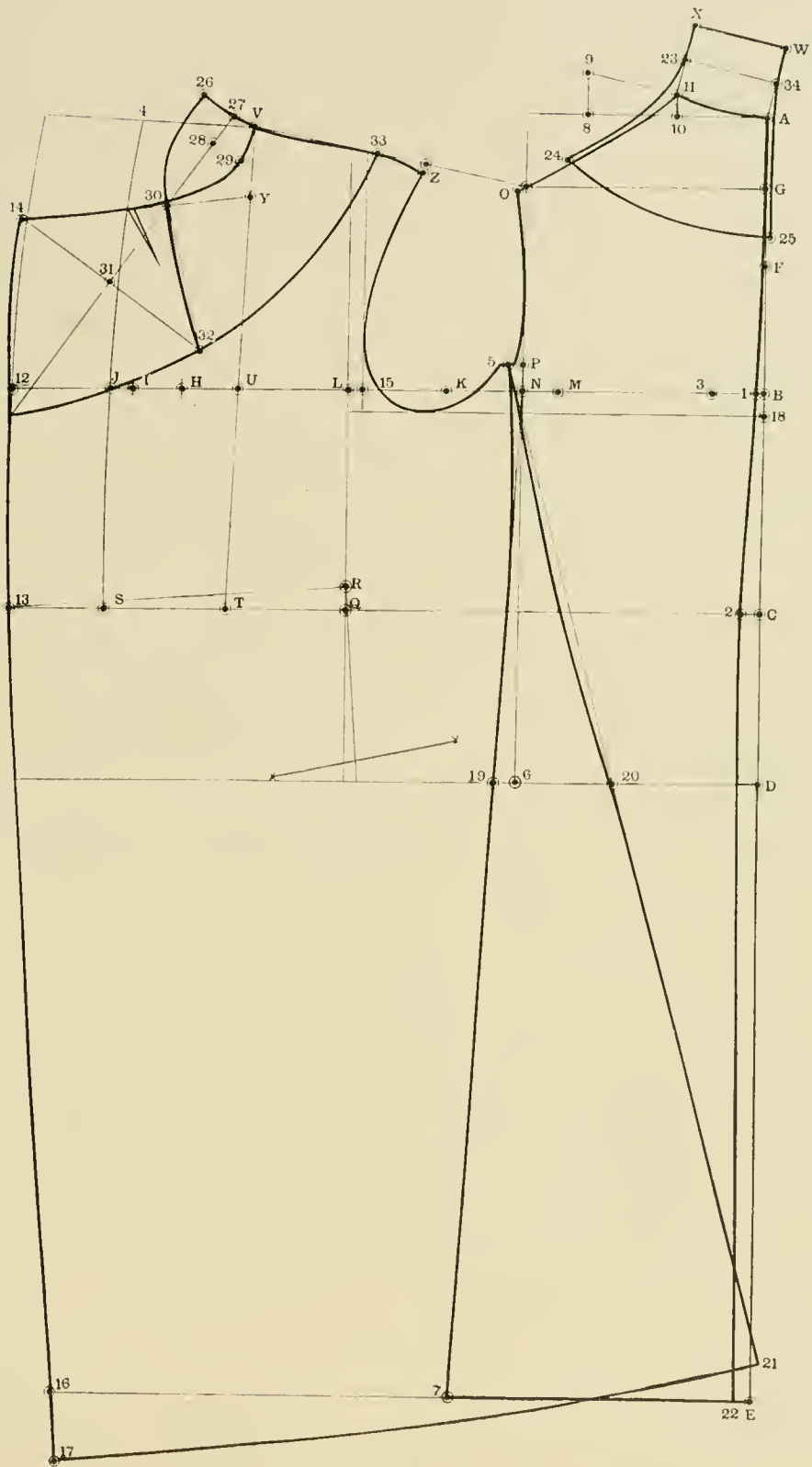

DIAGRAM 71

## DIAGRAMS 75 &amp; 76.

## THE SLEEVE.

Diagrams 75 and 76 show how to measure the armhole for the sleeve. Measure the armseye closely, beginning at 1 through 2 and up to 3; now let us say that this armhole measures 19 inches; proceed as follows: point 2 is 1 inch above the breast line and is the front notch; for the back go up  $\frac{1}{4}$  of the armseye from the breast line and place the notch there.

Place the back shoulder along the front shoulder as shown on diagram 76; point 5 is the back notch; now measure the distance on a straight line from the front notch to the back notch; this distance is  $9\frac{1}{4}$  inches; make your sleeve as shown in the following way.

---

 DIAGRAM 77

From A to B is  $\frac{1}{3}$  of the armseye; from B to C is the same distance as from 4 to 5, which is the distance from the back notch to the breast line; from B to D is 1 inch always which is the same distance as the front notch from the breast line; B to E is full length of the sleeve; square out from C, B and E. This sleeve is to be made up with very little wadding; should a regular pad be desired for the sleeve head, make the distance from A to B,  $\frac{1}{3}$  armseye plus  $\frac{1}{4}$  inch, but the distance from B to C always remains the same as from the breast line to the notch.

From D to K is  $9\frac{1}{4}$  inches which is the same distance as from 2 to 5 on a straight line (diagram 76); square down from K; this locates L; point M is halfway between L and B; square up from M; this locates points O and N; point P is halfway between A and N; draw a line from P to D; place the square to line O-E and square back; from E to U is the width of the sleeve desired plus 1 inch for seams.

In frock coats or sack coats where an underarm fish is cut out, make the distance from K to V  $\frac{1}{2}$  inch; in sack coats or overcoats where no underarm fish is cut out, make the distance from K to V,  $\frac{1}{4}$  inch; in this case from K to V is  $\frac{1}{2}$  inch; add  $\frac{1}{4}$  inch width on top of the undersleeve at V for a seam; draw a line from V to M; from B to G is  $1\frac{1}{4}$  inches; E to H is the same; B to I is the same distance as B to G; E to J is the same distance as E to H; hollow the upper and undersleeve as at Q and R,  $\frac{3}{4}$  inch and add the same amount from S to T and shape the sleeve; in shaping the undersleeve go up from I to F a full  $\frac{1}{4}$  inch.

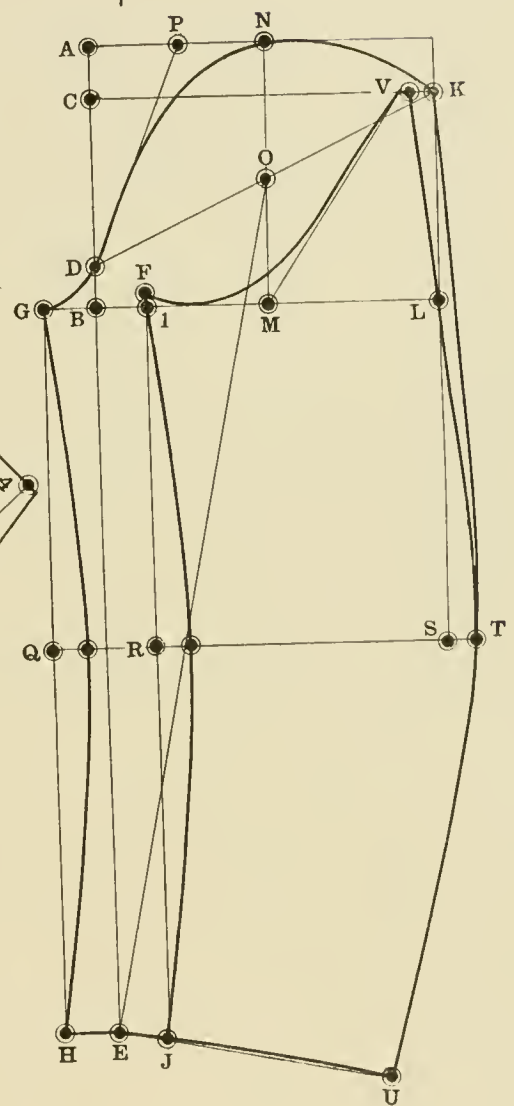
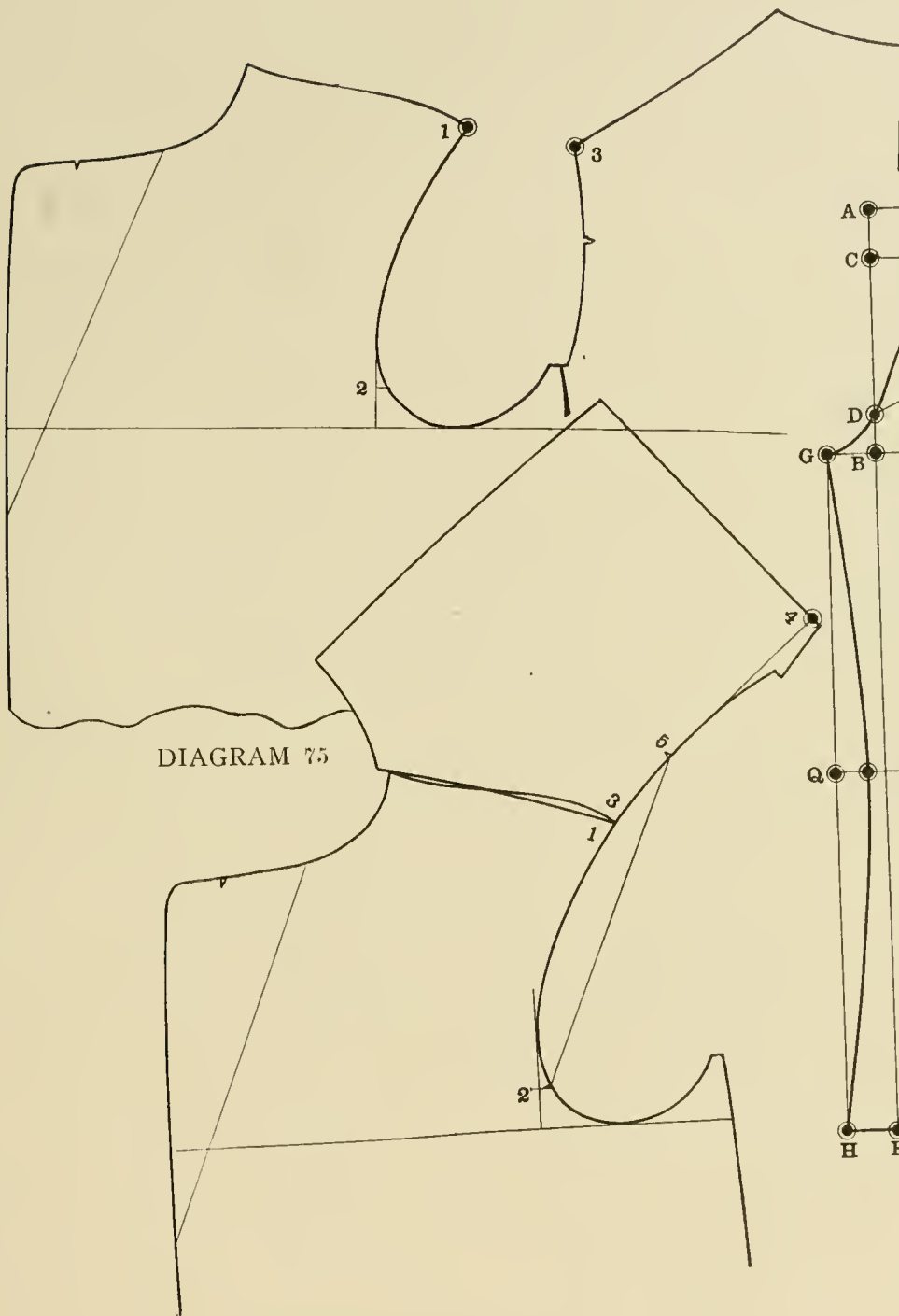

DIAGRAM 77

### DIAGRAM 78

In a case of measuring the armhole on a frock coat, proceed in the same manner as described on diagrams 75 and 76, but before measuring the distance from the back notch to the breast line, let the back overlap the sidebody a  $\frac{1}{2}$  inch before measuring same.

---

### DIAGRAM 79

This sleeve is made the same as shown on diagram 77 with the exception that it is cut half and half, therefore add a seam at D which is an extra  $\frac{1}{4}$  inch to the upper and under sleeve as shown and finish the same as the other sleeve.

---

### DIAGRAM 80

If an extra easy sleeve is desired, make your sleeve as shown in this diagram. From A to B is  $\frac{1}{3}$  the armscye; B to C is the same distance as from the breast line to the back notch; from B to D is 1 inch always; from D to K is the width of the sleeve as shown on Diagram 76; square down from K; this locates I; M is halfway between I and B; square up from M; this locates points O and N; point P is halfway between A and N; draw a line from P to D; from I down to S in this case is  $\frac{1}{2}$  inch; place the square to S-B and square down; this locates point H; square back from H by line O-H and make the width of the sleeve according to style and finish the same as shown in diagram 77.

DIAGRAM 78

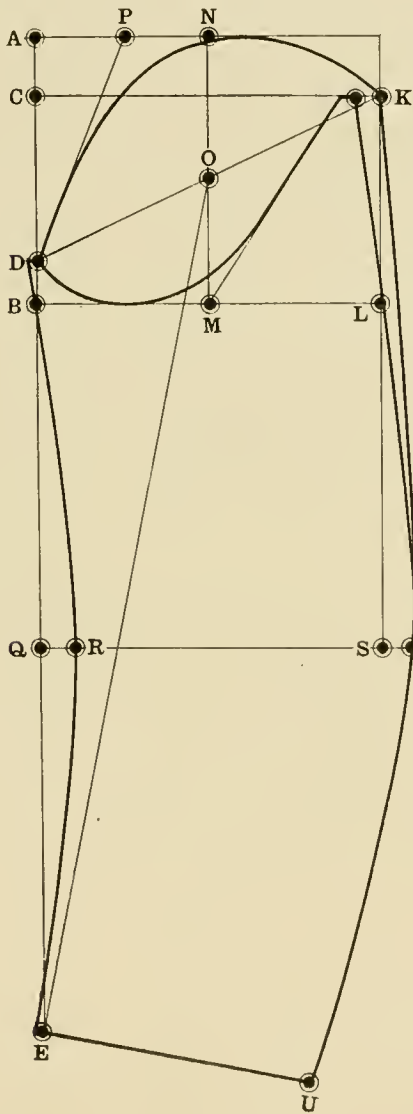
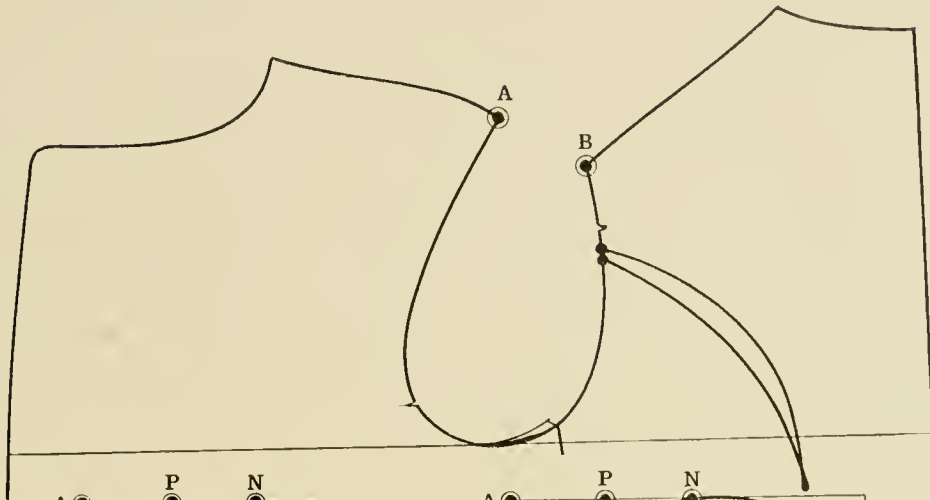

DIAGRAM 79



DIAGRAM 80

## DIAGRAM 81

In cutting sleeves for overcoats, the same method is used as for under coats. The only change made is that the overcoat sleeve is cut  $1\frac{1}{2}$  inches larger around the wrist than an under coat sleeve of the same size would be. To measure the armhole for a Box Overcoat, proceed as follows: do not add the overlap as from 1 to 2 in the measuring of the armholes, but begin as at A and measure around through 2 straight up to B; for the overlap between 1 and 2 there is an addition made on the undersleeve.

## DIAGRAM 82

## SLEEVE FOR BOX OVERCOAT.

The size of this armhole is 21 inches; the width of the sleeve on a straight line is 10 inches.

Square down and out from A.

From A to B is  $\frac{1}{3}$  of the armseye; B to C is  $\frac{1}{4}$  of the armseye; B to D is 1 inch; square out from C and B; from D to K is 10 inches; square down from K; this locates L; M is halfway between L and B; square up from M; this locates points O and N; point P is halfway between A and N; draw a line from P to D; from M back to V is  $\frac{1}{2}$  inch; take out nothing at K but draw a line from K to V; this gives the extra  $\frac{1}{2}$  inch that is required for the overlap of the armhole from 1 to 2 (diagram 81); add on a seam to the undersleeve as shown.

From B to E is the sleeve length; in the case of an overcoat, the sleeve is cut the same length as for the under coat; there is no need to add any length because the backpart and shoulder having become wider and the armhole deeper, this gives sufficient length to the sleeve by making it the same length as the under coat; square back from E by line O-E.

From E to U in this case is  $7\frac{1}{2}$  inches; this will finish the sleeve 14 inches and will make it  $1\frac{1}{2}$  inches wider than an under coat sleeve of the same size would be. Add from B to G  $1\frac{1}{4}$  inches and from E to H the same; reduce the undersleeve from B to I and E to J the same amount as has been added to the upper sleeve; hollow at Q and R,  $\frac{3}{4}$  inch and add the same amount from S to T.



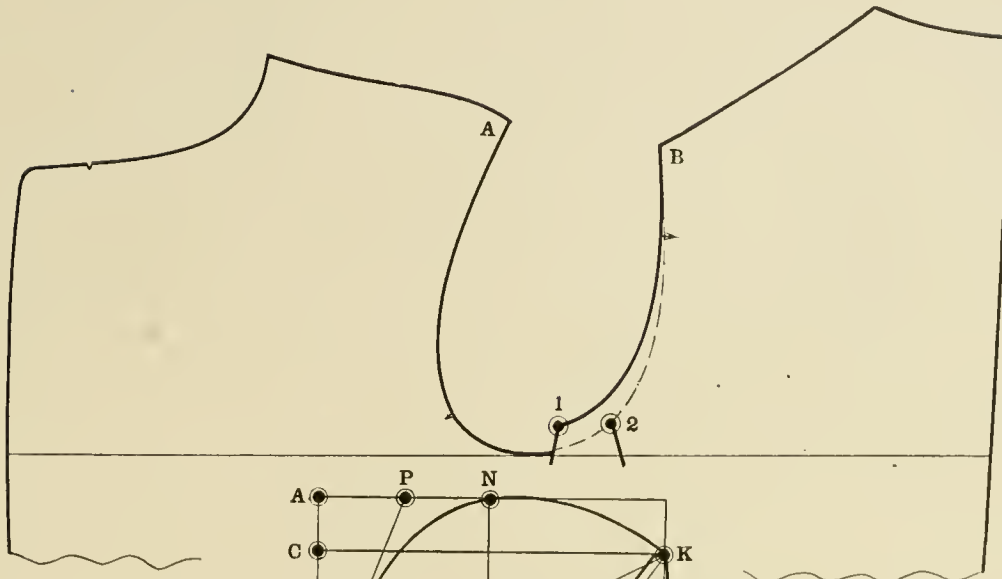

DIAGRAM 81

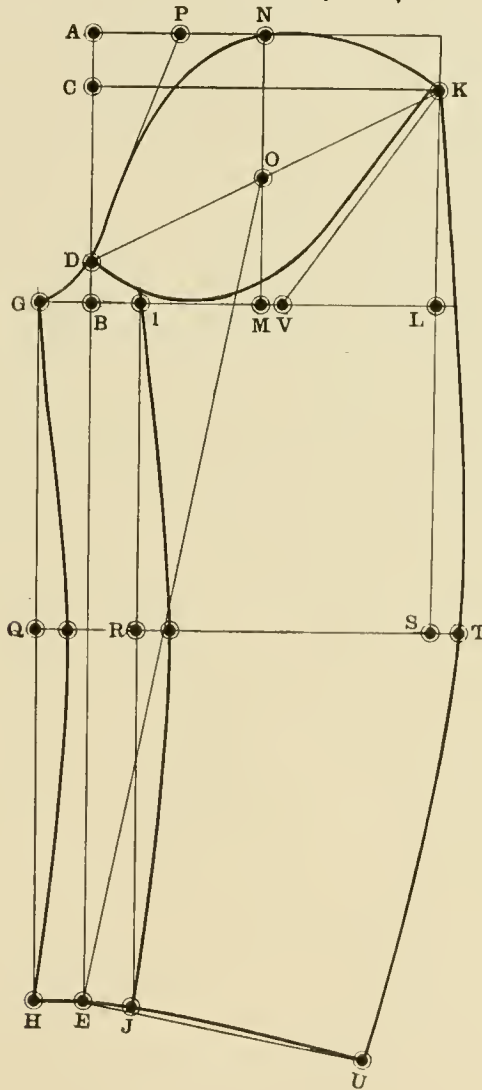

DIAGRAM 82

## DIAGRAMS 83 &amp; 84.

For a narrow shoulder manipulate the sleeve as follows: first of all cut all your shoulders natural width; by natural width, I mean that after the back width is squared up, make the distance from 1 to 2 at least  $\frac{1}{4}$  inch.

Now see diagram 83. After the pattern is finished with the natural shoulder, measure the armseye and mark the notches; now draft the sleeve for the natural armseye and proceed as follows: place the back shoulder along the front shoulder and reshape the shoulder width, see diagram 83, broken line, but do not cut out.

Now see diagram 84. Place the original back notch to the sleeve head as at 3; extend line 6-4 up and make the notch as at 4; now reshape as indicated by the broken line; lengthen the undersleeve as from 3 to 4 to make it correspond with the upper sleeve and reshape.

DIAGRAM 83

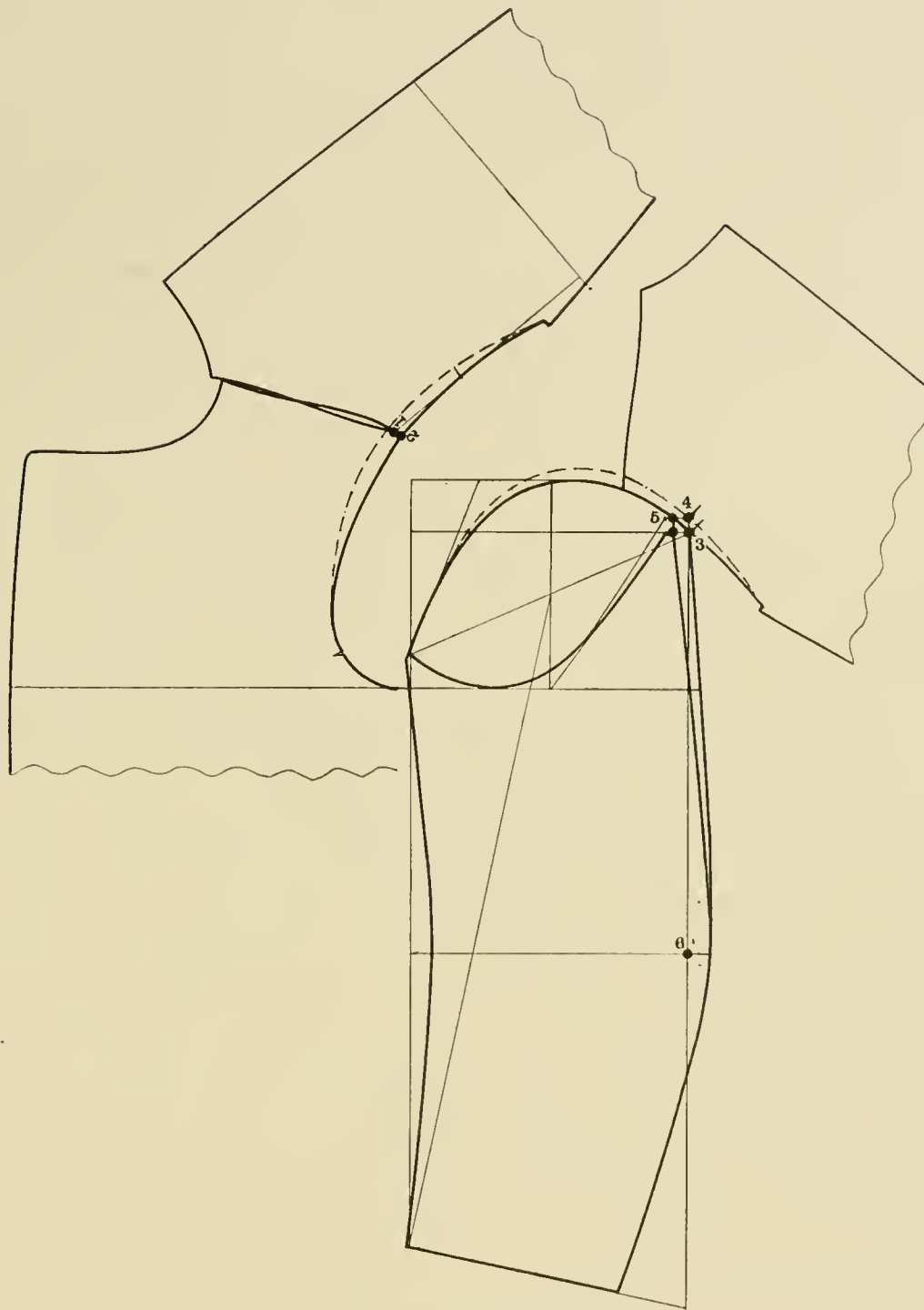

DIAGRAM 84

## AMERICAN GARMENT CUTTER

## DIAGRAM 85

## RAGLAN OVERCOAT.

The measurements as taken over the waistcoat are as follows:

Scye depth .....	9½ inches	Overshoulder .....	18 inches
Waist length .....	17 inches	Blade .....	13¼ inches
Full length whatever style calls for.		Breast .....	39 inches
Strap .....	12¾ inches	Waist .....	35½ inches

Square down and out from A.

From A to B is scye depth plus ¼ inch; B to C is ¾ inch; A to D is waist length plus ¾ inch; E is full length; F is halfway between A and C; G is halfway between A and E; square out from G, B, C, D and E.

From D to 2 is ¾ inch; draw a line from F through 2 down; this locates 22; square out from 22; from 1 to 21 is 1½ inches; 21 to H is ½ breast; H to I is 1½ inches; I to J is ¾ inch; K is halfway between 21 and H; K to L is 3½ inches; square down from L to locate Q; apply the blade measure from 21 to L which is 13¼ inches and square up; L back to 15 is ½ inch; square up and down from 15; point M is halfway between I and 15; from M to N is 1¼ inches; square up from N.

From A to 8 is 6⅔ inches; 8 to 9 is 1½ inches; draw a line from A to 9; A to 10 is ½ breast; square up from 10 to locate 11; draw a line from 11 to O and shape the back; point 4 is where the armhole crosses the breast line; square down from 4 to locate 19; from 19 to 6 is 1½ inches; 6 to 20 is 3½ inches; draw a line from 4 through 6 down; this locates 7 and draw a line from 4 through 20 down; from 4 to 18 is the same distance as from 4 to 7; from 3 to S is ½ waist; point T is halfway between Q and S; point U is halfway between L and I; draw a line from T through U up.

From A to 11 and L to V is the strap measure plus 1 inch; draw a line from V to O; from V to Z is ⅜ inch less than 11 to 24; shape the shoulder and armseye; square forwards from V by line T-U; V to W is ½ breast plus ¾ inch; draw a rounding line from W to J; W to X is the depth of the gorge desired; V to Y is ⅛ breast; shape the gorge; from Q to R is 1¼ inches; S to 13 is 1¾ inches; J to 12 is the same; square down from 13 by line R-13; this locates 16.

From 16 to 17 is ⅛ breast; shape the front edge and bottom of forepart; now add from 1 to P, 1¼ inches and from 7 to 5 the same and reshape the backpart.

Now measure the armhole the same as shown on Diagram 81, that is, from 30 down to 15 and through 4 up to 21; point 15 is 1 inch above the lower breast line; from the lower breast line to 14 is ¼ of the armseye; make the back notch at 11. The measurements for this armhole are as follows:

Armseye circumference .....	21½ inches
Back notch at 14 to lower breast line .....	5⅜ inches

In this coat it is not necessary to take the width of the armhole from notch to notch on a straight line; now draw a line on the backpart from 11 into the armhole; place the square to that line until the right angle touches at 24; go out from 23 to 25 about ¾ inch more or less according to style and shape the backpart as from 11 through 25 into the armhole.

## THE FOREPART.

Draw a line as from V to 15; place the square to that line until the right angle touches at 30; from 29 to 31 is ¾ inch; from V to 26 is ½ inch; shape the front part from 26 through 31 to 15; now measure the distance on the backpart from the notch up to 11; in this case it is 7½ inches; measure the distance on a straight line from 15 to 26, in this case it is 10 inches.

Measure the width of the shoulder at the narrowest point as from 27 to 28, in this case it is 6 inches; now proceed with your sleeve as follows:

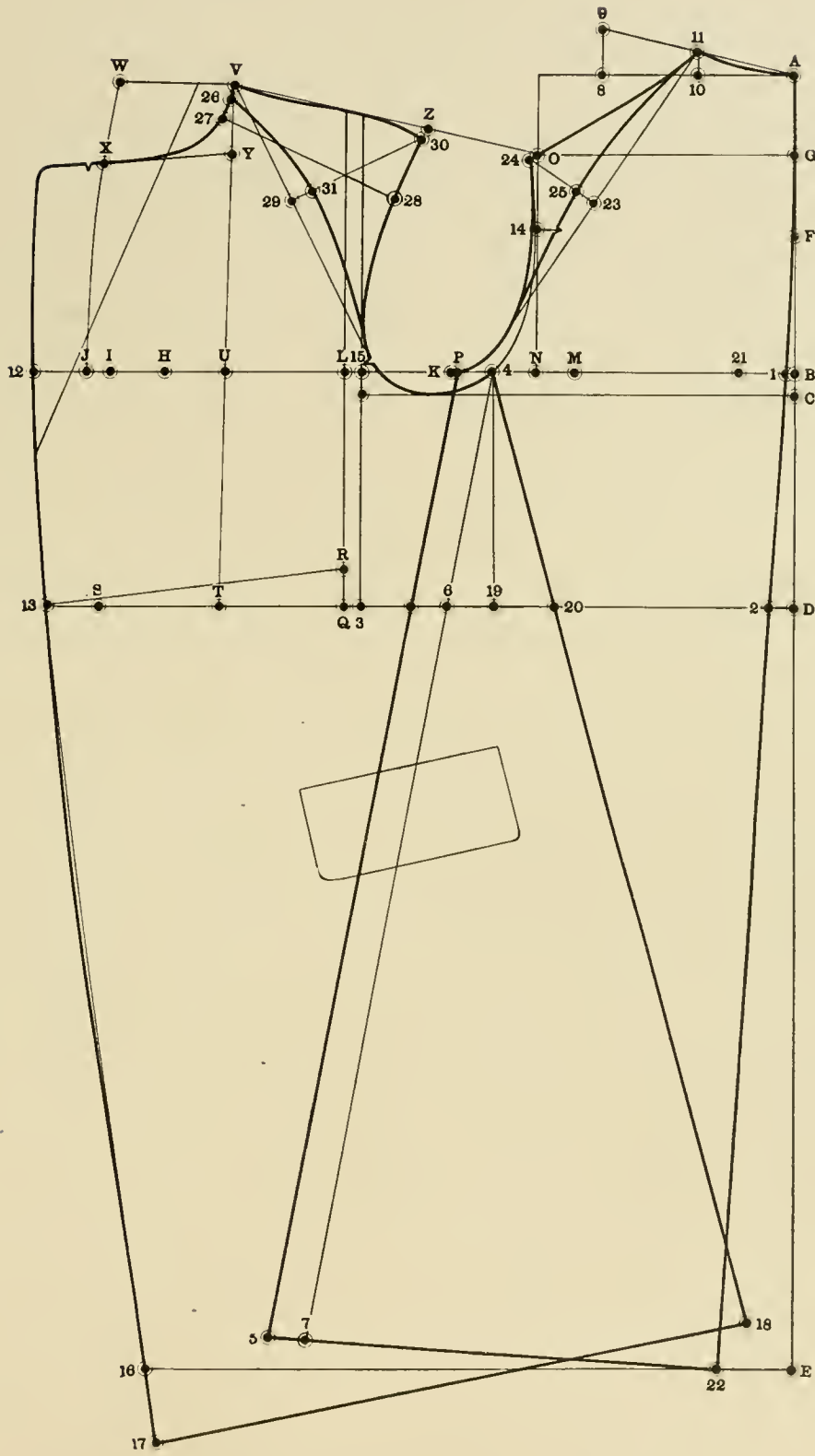

DIAGRAM 85

## DIAGRAM 86

## THE SPLIT SLEEVE.

Square down and out from A.

From A to D is  $\frac{1}{3}$  of the armseye; D to C is the same distance as from the breast line up to the back notch; D to E is 1 inch; square out from C and D; from E to F is  $\frac{1}{2}$  of the armseye; square up and down from F; this locates G; point N is halfway between D and G; square up and down from N; this locates points Z and X.

From D to B is the sleeve length; square back from B by line Z-B; from B to O is the width of the sleeve desired; from N back to H is  $\frac{1}{2}$  inch; draw a line from F to H and shape the under sleeve; from F to T is  $\frac{3}{8}$  inch less than the distance from the back notch up to H, in this case  $1\frac{1}{8}$  inches.

From E to Q is the same distance as from 15 to 26, in this case 10 inches; from X to W is the same distance as from 28 to 27, in this case 6 inches; sweep from Q to R pivoting at E; sweep from T to U pivoting at F; sweep from W forwards to R and backwards to U pivoting at X; from U to V is  $\frac{3}{4}$  inch; R to S is the same; draw a line from R to E; this locates Y. Hollow the sleeve from Y to I the same amount as the shoulder has been rounded from 29 to 31; draw a line from V to X and from S to X; point P is halfway between O and B; draw a line from Z through N down to P; add  $\frac{3}{8}$  inch or  $\frac{1}{2}$  inch each side of line Z-P and cut out the sleeve; reduce the sleeve from V to I,  $\frac{3}{8}$  inch and finish.

## DIAGRAM 87

If a whole sleeve is desired, proceed as in this diagram: from A to B is  $\frac{1}{3}$  of the armseye; B to C is the same distance as from the back notch to the lower breast line; B to D is 1 inch; from D to K is  $\frac{1}{2}$  of the armseye; square up and down from K; this locates L; point M is halfway between B and L; square up from M; this locates O; M to Y is  $\frac{1}{2}$  inch; from D to Z is the same distance as from 15 to 26 on diagram 85; from K to I is the same distance as from back notch up to H.

Add from K to V the same amount as has been cut off from the actual backpart at H to its present raglan style back, in this case it is  $\frac{3}{4}$  inch; sweep forwards from I pivoting at L; sweep backwards from Z pivoting at M; this locates point P; draw a line from P to D; from P to 2 is 1 inch; draw a line from 2 to V, also draw a line from V to Y.

Hollow the sleeve from 3 to I the same amount as the shoulder has been rounded from 29 to 31; shape the undersleeve straight down from V and shape the upper sleeve and finish the same as other sleeves.

In sewing up the side of this sleeve, the upper sleeve is to be full in about  $\frac{1}{2}$  inch between L and V. The best way to sew in this sleeve is as follows: put the stay in from about 1 inch above the notch to within about 1 inch below the shoulder point at P and draw the sleeve in  $\frac{3}{4}$  inch, also lay your tape 1 inch below 2 and draw that part in about  $\frac{3}{4}$  inch between 2 and V; press the fullness away on both sides before joining to the shoulder.

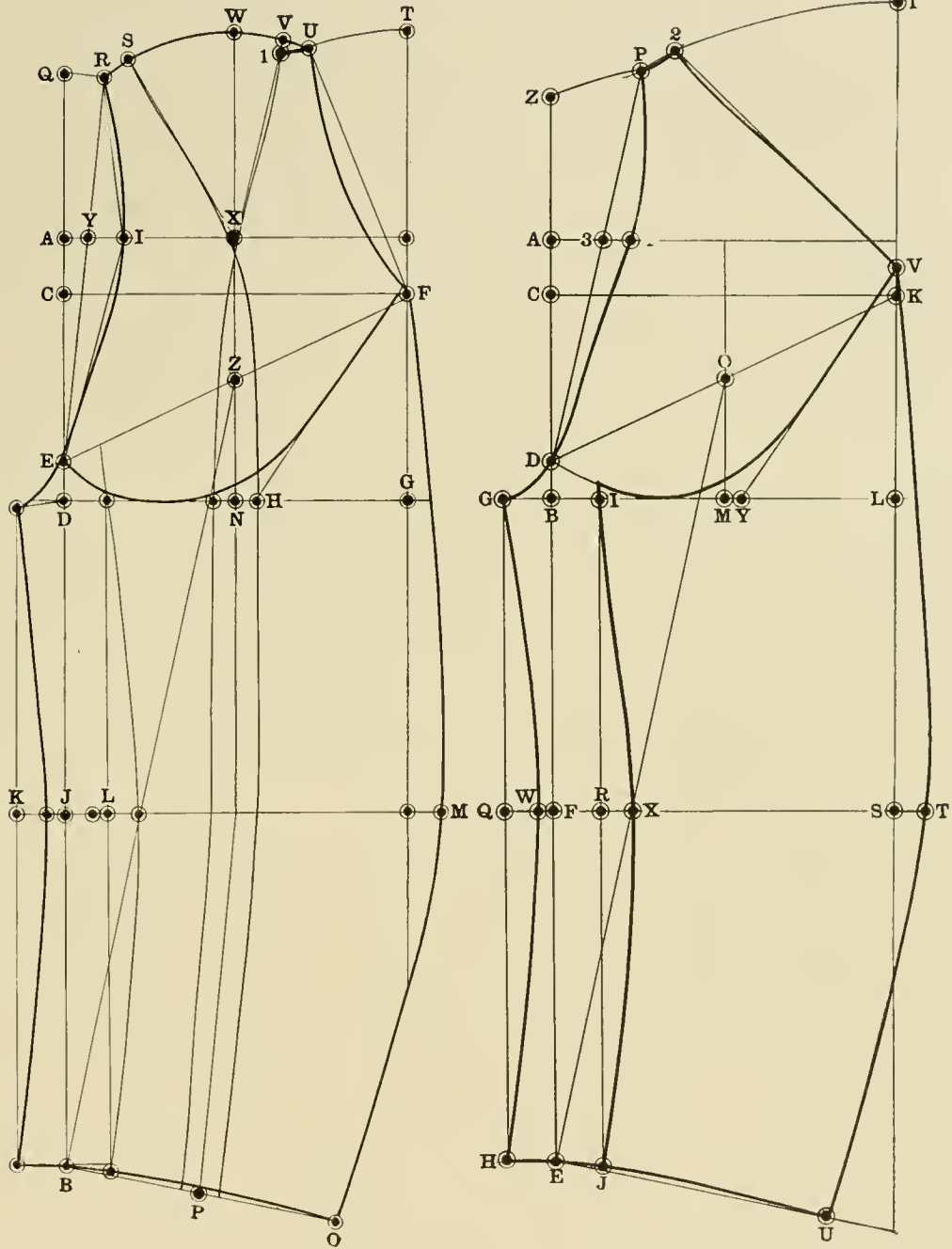

DIAGRAM 86

DIAGRAM 87

## AMERICAN GARMENT CUTTER

## DIAGRAM 88

## BALMACAAN.

This coat is cut the same as either the Box Coat or the Raglan Coat, therefore we will cut same by proportion.

Breast .....	38	inches
Waist .....	34½	inches
Height .....	5 ft., 7 ins.	

Square down and out from A.

From A to B is  $\frac{1}{3}$  breast plus  $3\frac{1}{4}$  inches; B to C is  $\frac{3}{4}$  inch; A to D is  $\frac{1}{4}$  height plus  $\frac{3}{4}$  inch; E is full length; F is halfway between A and C; G is halfway between A and F; square out from G, B, C, D and E.

From D to 2 is  $\frac{3}{4}$  inch; draw a line from F through 2 down; this locates 22; square out from 22; from 1 to 21 is  $1\frac{1}{2}$  inches; 21 to H is  $\frac{1}{2}$  breast; H to I is  $1\frac{1}{2}$  inches; I to J is  $\frac{3}{4}$  inch; K is halfway between 21 and H; from K to L is  $3\frac{1}{2}$  inches; square up and down from L; L back to 15 is  $\frac{1}{2}$  inch; square up and down from 15.

Point M is halfway between 1 and 15; M to N is  $1\frac{1}{4}$  inches; square up from N; from A to 8 is  $6\frac{3}{8}$  inches; 8 to 9 is  $1\frac{1}{2}$  inches; draw a line from A to 9; from A to 10 is  $\frac{1}{6}$  breast; square up from 10 to locate 11; draw a line from 11 to O and shape the back; point 4 is where the armhole crosses the breast line; square down from 4; this locates 19; from 19 to 6 is  $1\frac{1}{2}$  inches; from 6 to 20 is  $3\frac{1}{2}$  inches; draw lines from 4 through 6 to 7 and from 4 through 20 to 18; 4 to 18 is the same distance as from 4 to 7; from 3 to S is  $\frac{1}{2}$  waist.

Point T is halfway between Q and S; point U is halfway between L and I; draw a line from T through U up; from A to 11 and L to V is  $\frac{1}{4}$  of 38 breast plus 4 inches, in this case  $13\frac{1}{2}$  inches; draw a line from V to O; from V to Z is  $\frac{3}{8}$  inch less than the back shoulder width; shape the shoulder and armseye.

Square forwards from V by line T-U; V to W is  $\frac{1}{6}$  breast plus  $\frac{1}{2}$  inch; draw a rounding line from W to J; W to X is  $\frac{1}{6}$  breast; V to Y is  $\frac{1}{8}$  breast; draw a line from Y to X and shape the gorge; J to 12 is  $1\frac{1}{2}$  inches; S to 13 is the same; Q to R is  $1\frac{1}{4}$  inches; square down from 13 by line R-13; this locates 16; 16 to 17 is  $\frac{1}{8}$  breast; shape the front edge and bottom of forepart.

## THE COLLAR.

Draw a line from X through V; from X to 29 is  $\frac{1}{2}$  of the shirt collar size; the normal shirt collar for a 38 breast is 15 inches, therefore the distance from X to 29 is  $7\frac{1}{2}$  inches; point 30 is halfway between 29 and X; square up from 30; 30 to 31 is  $1\frac{1}{4}$  inches; shape the collar from 29 through 31 to X.

From 29 to 32 is  $\frac{1}{6}$  breast; place the square to points 29-32 and square out to 34; from 32 to 34 is  $1\frac{1}{4}$  inches; 29 to 33 is  $1\frac{1}{4}$  inches; X to 39 is  $\frac{1}{2}$  inch; shape the collar stand from 33 through 34 to 39; from 34 to 35 is  $\frac{3}{4}$  inch; place the square to points 33-35 and square out to 36; 33 to 36 is the width of the collar desired; 34 to 37 and 39 to 38 are the same; shape the collar as shown and finish.

This collar stand is to be stretched until it folds over as shown by the crease line; the collar size as it is now will be two inches larger than the shirt collar which is correct for an overcoat. Now measure the armseye as from 24 through 15 and 4 up to O; the circumference of this armseye is 21 inches; point 15 is 1 inch above the lower breast line; from the lower breast line to back notch is  $\frac{1}{4}$  armseye; now draw a straight line on the backpart from 11 to the armseye; place the square to that line until the right angle touches at O.

Add from 27 to 28,  $\frac{1}{2}$  or  $\frac{3}{4}$  inch rounding and shape the backpart; draw a line on the forepart from 15 to V; place the square to that line until the right angle touches at Z; make the distance from 23 to 26 according to style, in this case about  $\frac{1}{2}$  inch; from V to 25 is  $\frac{1}{2}$  inch; shape the forepart from 25 through 26 into 15.



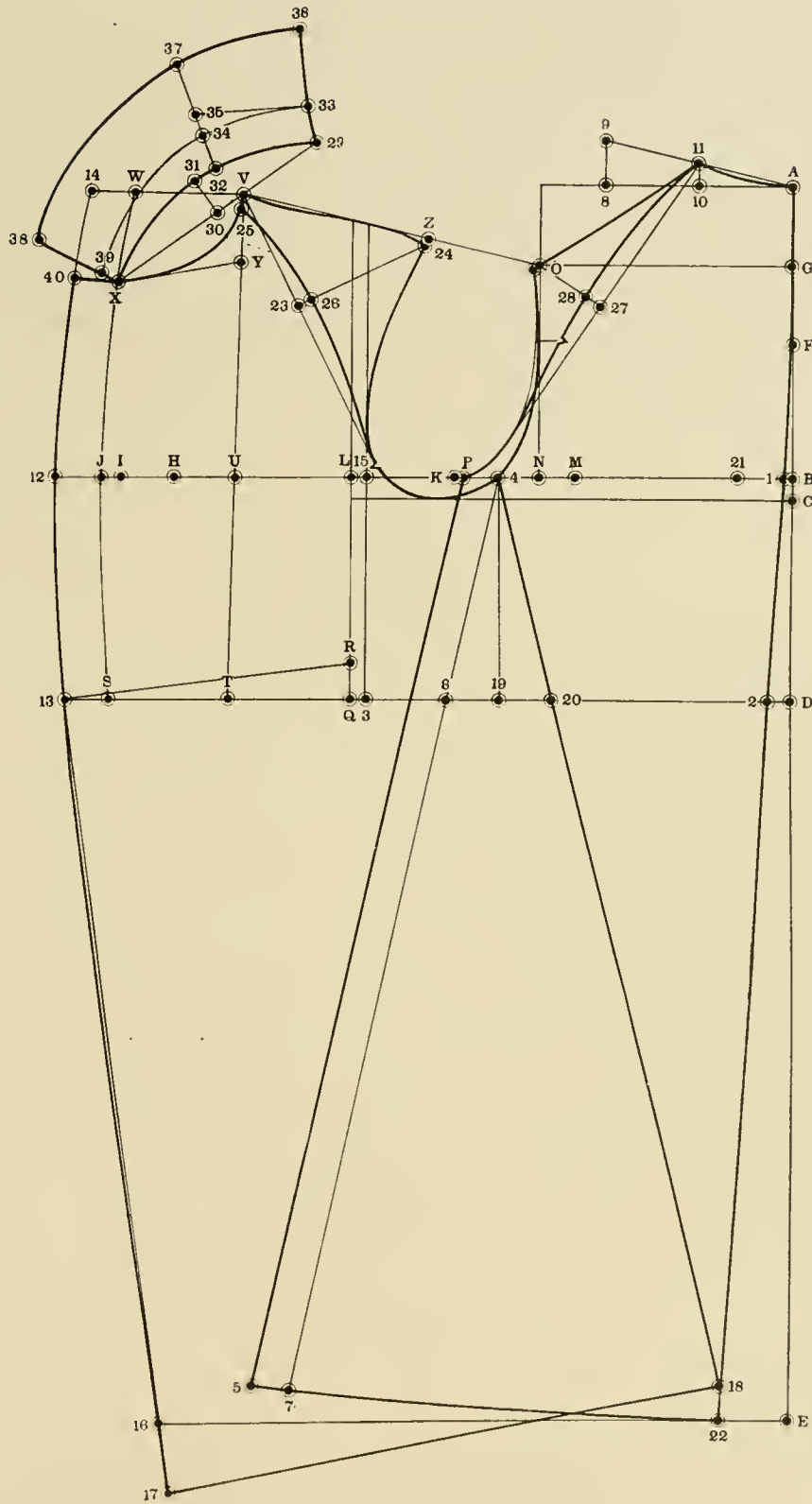

DIAGRAM 88

## DIAGRAM 89

Now cut out the forepart and backpart, place them side seam to side seam and proceed as shown on diagram 89: split the backpart as from A to B and B to C; open the backpart from C to D as much as desired, in this case about  $3\frac{1}{2}$  inches, also split the forepart as from E to F and F to H; open from H to G the same amount as the backpart has been opened from C to D.

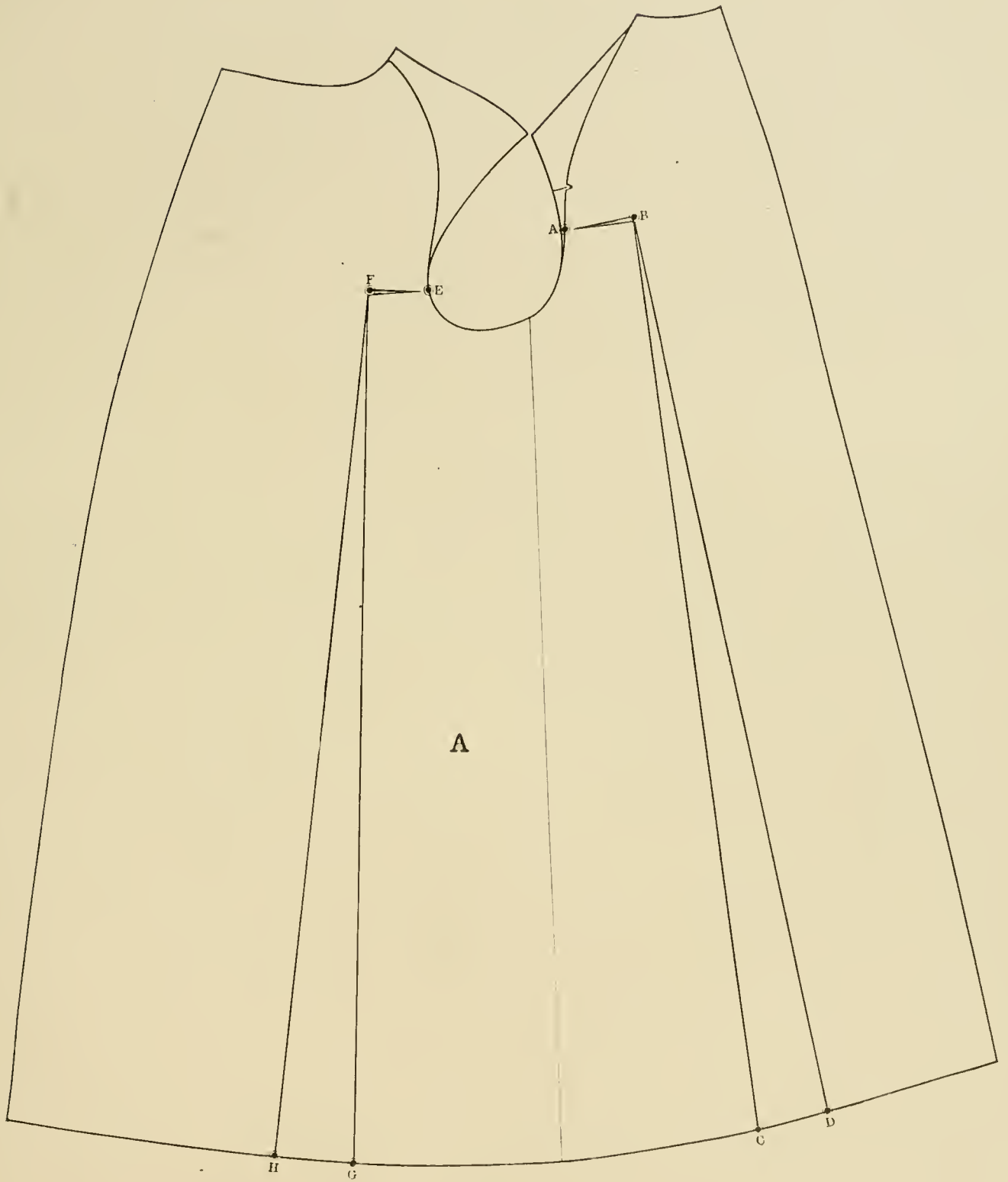

DIAGRAM 89

## DIAGRAM 90

(Diagram 90). The forepart and backpart being now in one piece fold pattern over until both sides of the armseye as shown come together as at letter A, also the distance from 1 to 2 should be about  $1\frac{1}{4}$  inches; crease the pattern down as shown.

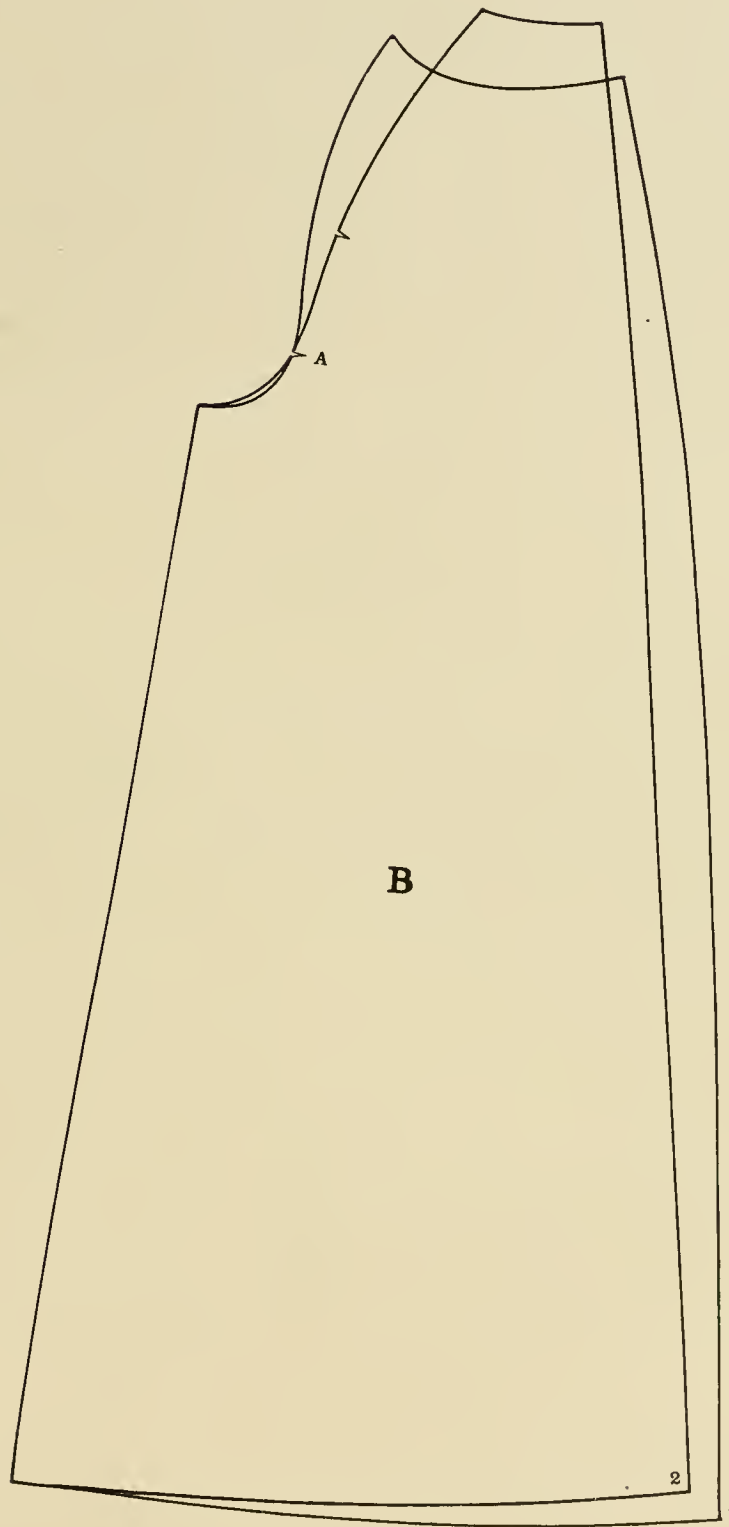

DIAGRAM 90

## DIAGRAM 91

Now take diagram 91: line B, C and E represent the line where the pattern was creased, and this practically constitutes the center of the coat; now go down from A to D the depth of the armhole desired, in this case it is 1 inches; square back from D; this locates C; measure the distance from A to B, in this case it is  $3\frac{1}{4}$  inches; now draw lines from the back notch to C and from the front notch to C and shape the armseye as shown. The armseye measurements will be noted on this diagram.

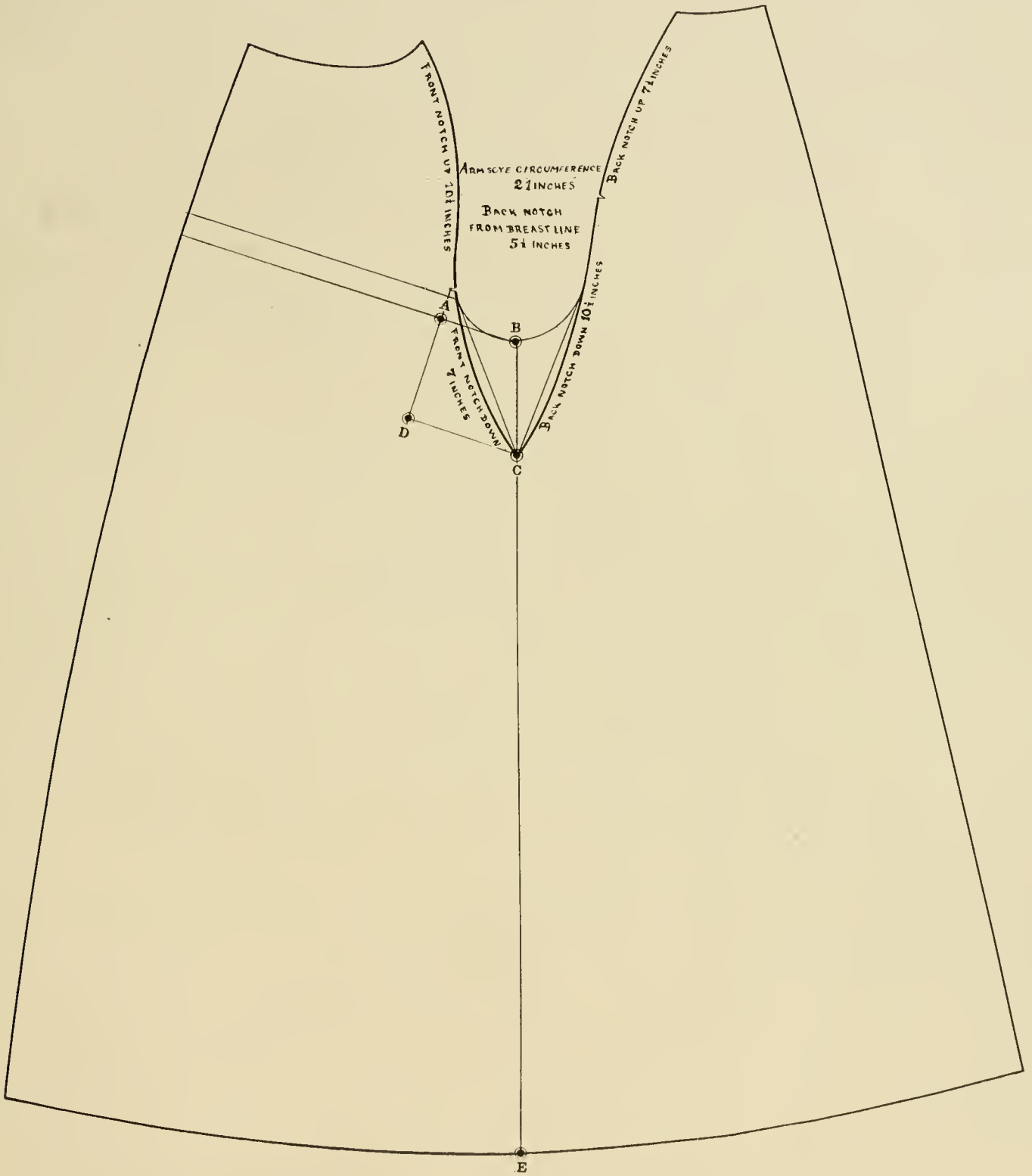

DIAGRAM 91

## DIAGRAM 92

## BALMACAAN SLEEVE.

Square down and out from A.

From A to B is  $\frac{1}{2}$  armseye; B to C is the same distance as from the breast line to the back notch which is  $\frac{1}{4}$  armseye; B to D is 1 inch; square out from C and B; from D to E is  $\frac{1}{2}$  armseye; square up and down from E; this locates Z; point Y is halfway between B and Z; square up and down from Y; this locates M.

From D to P is the same distance as from the front notch up to the shoulder point, in this case  $10\frac{1}{4}$  inches; from E to N is  $\frac{3}{8}$  inch less than from the back notch up, in this case  $7\frac{1}{8}$  inches; from M to O is the same as the shoulder width at the narrowest part, in this case 6 inches; sweep from P back pivoting at D; sweep from N forwards pivoting at E; sweep from O forwards and backwards pivoting at M; this locates points Q-S.

Draw a line from Q to E, also draw a line from S to D; hollow from W to X the same amount as the front part has been rounded from the straight line; hollow out between Q and E about  $\frac{3}{8}$  inch; Q to R is  $\frac{3}{4}$  inch; S to T is the same; draw lines from R to M and from T to M; take off from R to 12,  $\frac{3}{8}$  inch; from B to G is the sleeve length; place the square to M-G and square back.

From G to 8 is the width of the sleeve desired; point 10 is halfway between G and 8; shape the upper sleeve as shown, adding  $\frac{1}{2}$  inch each side of line E-H-L-10, from B to F is  $\frac{1}{2}$  the distance of from A to D on diagram 91; square forwards and backwards from F; from F to I is the same distance as from A to B on diagram 91, plus  $\frac{1}{4}$  inch for a seam, in this case it is  $3\frac{1}{4}$  inches plus a seam; square down from I; from F to 1 is  $9\frac{3}{4}$  inches; from I to F and 1 to 2 is the same distance as from F to 1, which is  $9\frac{3}{4}$  inches; add a seam at 2 and square down; draw a line from E to 2; from E to 3 is  $\frac{3}{4}$  inch more than from the back notch to C. (diagram 91) in this case it is  $11\frac{1}{4}$  inches.

From D to J is  $\frac{3}{8}$  inch more than from the front notch to C; shape the upper and under sleeve as shown and draw lines from J to K and from 3 to 4; from 5 to 6 is the same distance as from 5 to 7; from 6 to 9 is the same distance as from 7 to 8; shape the sleeve as shown and finish.



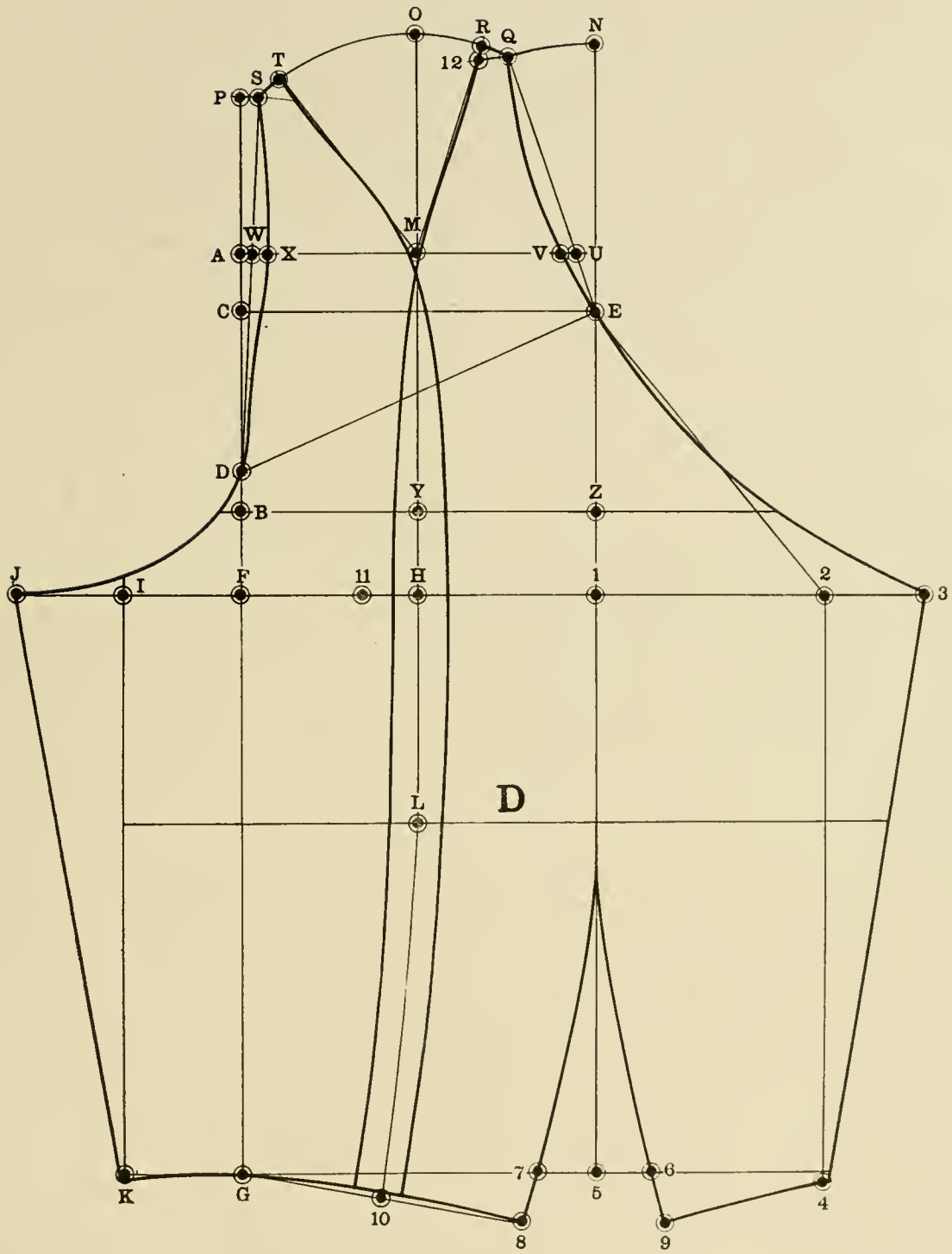

DIAGRAM 92

## DIAGRAM 93

## HOW TO MAKE SPLIT SLEEVE.

Place the back shoulder alongside of the front shoulder as shown in this diagram and proceed as follows: draw a line from A to F; from A to E is  $\frac{1}{8}$  breast; square back from E by line A-F; this shoulder should be made narrower than the ordinary shoulder; reshape the backpart as at H and I and the forepart as from G.



DIAGRAM 93

## DIAGRAM 94

The Sleeve is made as follows: (diagram 94)—place the upper sleeve to the edge of the backpart as shown in this diagram, the side seam of the upper sleeve to rest along the notch of the backpart and shape the shoulder as shown through A and B and C. Now split the sleeve on that line.

## DIAGRAM 95

The Forepart (diagram 95)—place the other half of the upper sleeve alongside of the forepart, notch to notch, and the sleeve head to the shoulder seam; shape the shoulder from D through E and the sleeve through F down; sweep from G to H pivoting at F; now add  $\frac{1}{2}$  inch for two seams from E to H, F to I and J to K; reshape the sleeve from H to L as shown.

DIABRAM 94

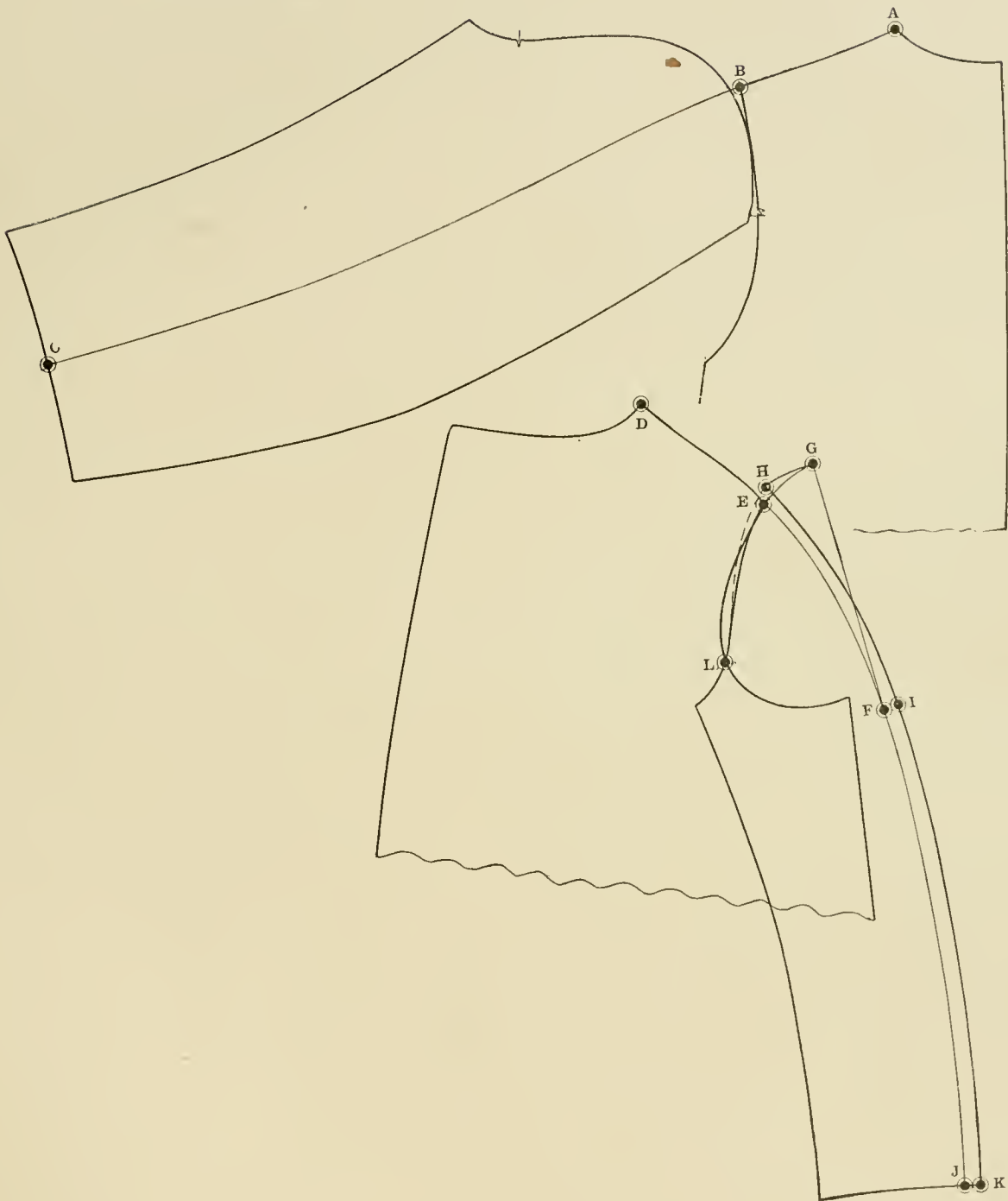

DIAGRAM 95

## DIAGRAMS 96 &amp; 97

If a two seam split sleeve is desired, proceed as follows: measure the armseye before the shoulder has been made narrower the same as shown on diagram 93 and proceed as follows: the measurement for the armseye circumference is  $21\frac{3}{4}$  inches and from the breast line to the back notch is  $5\frac{1}{2}$  inches.

Square down and out from A.

From A to B is  $\frac{1}{3}$  of the armseye; B to C is  $5\frac{1}{2}$  inches which is  $\frac{1}{4}$  armseye; B to D is 1 inch; square out from C and B; D to K is  $\frac{1}{2}$  armseye; square down from K; point M is halfway between B and L; square up and down from M; this locates W; P is halfway between W and A; draw a line from P to D; also draw a line from K to M; shape the upper and under sleeve as shown.

From B to H is the sleeve length; square out from H; this locates E and U; line A-B-H is on the fold and is not cut through; after the sleeve is cut out, open it as shown on diagram 97; split the sleeve on line W-M-E.

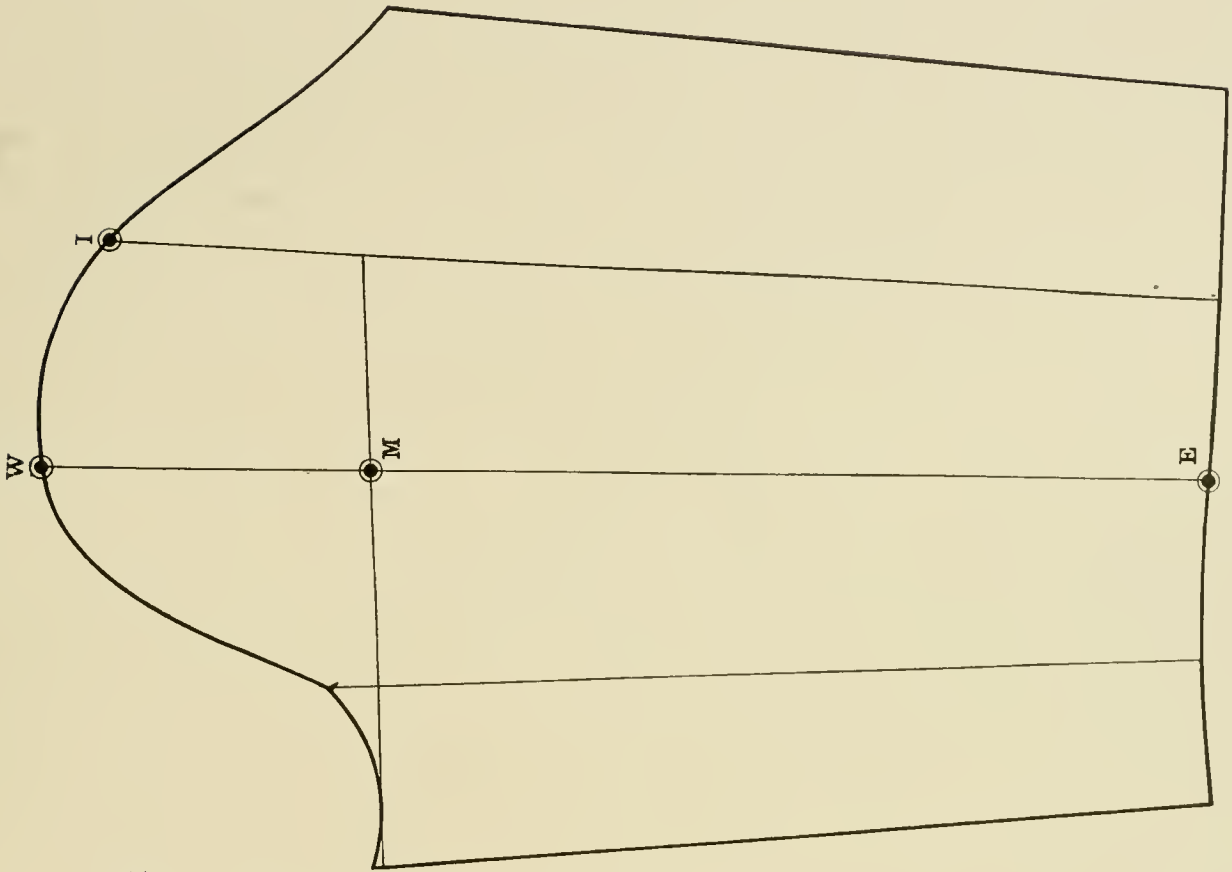

DIAGRAM 97

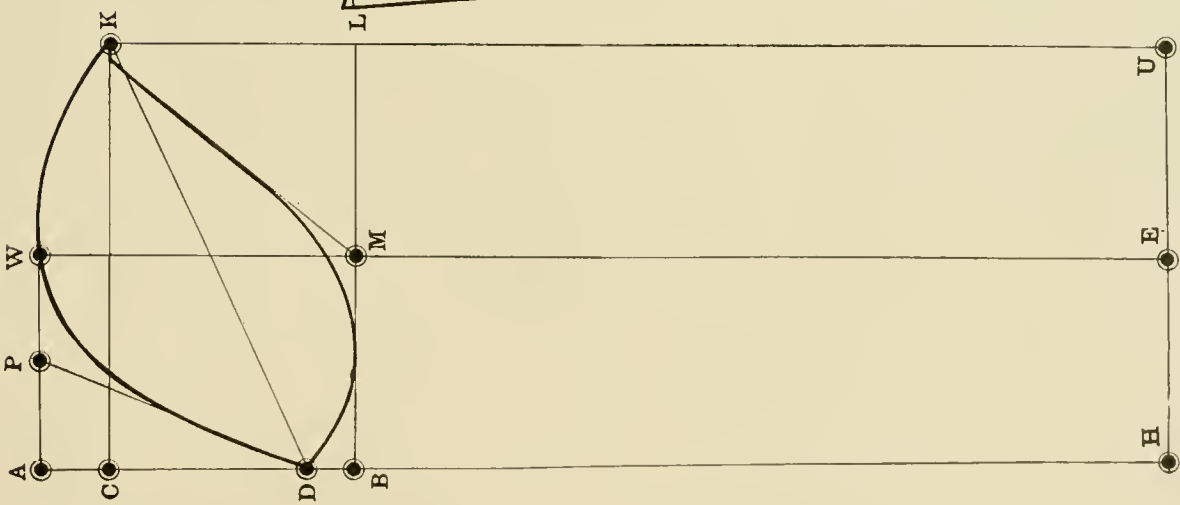

DIAGRAM 96

## DIAGRAMS 98, 99 &amp; 100

(Diagram 98) Notch your sleeve at I; place the backpart of the sleeve alongside of the backpart of the coat, point I which represents the sleeve notch to the back notch; from J to B is the width of the sleeve desired; from U to C is  $\frac{3}{4}$  inch; shape the sleeve from H through C to B; point B is  $\frac{3}{8}$  inch below line L-J.

(Diagram 99) Place the front part of the sleeve to the forepart of the coat, point E, which is the notch of the sleeve to the notch of the armhole and the sleeve head to the shoulder seam; from C to J is the same distance as from B to J on Diagram 98; from K to L is  $\frac{3}{4}$  inch; shape the sleeve from F through L to J; point J is  $\frac{3}{8}$  inch below line C-D.

Sweep from H to G pivoting at A; add from F to M,  $\frac{1}{2}$  inch and reshape the sleeve as per broken line.

To test the two parts of the sleeve, proceed as on Diagram 100; lay the two parts of the sleeve together as shown on this diagram; from M to G is the addition that has been made on the sleeve from M to G on Diagram 99.



DIAGRAM 98

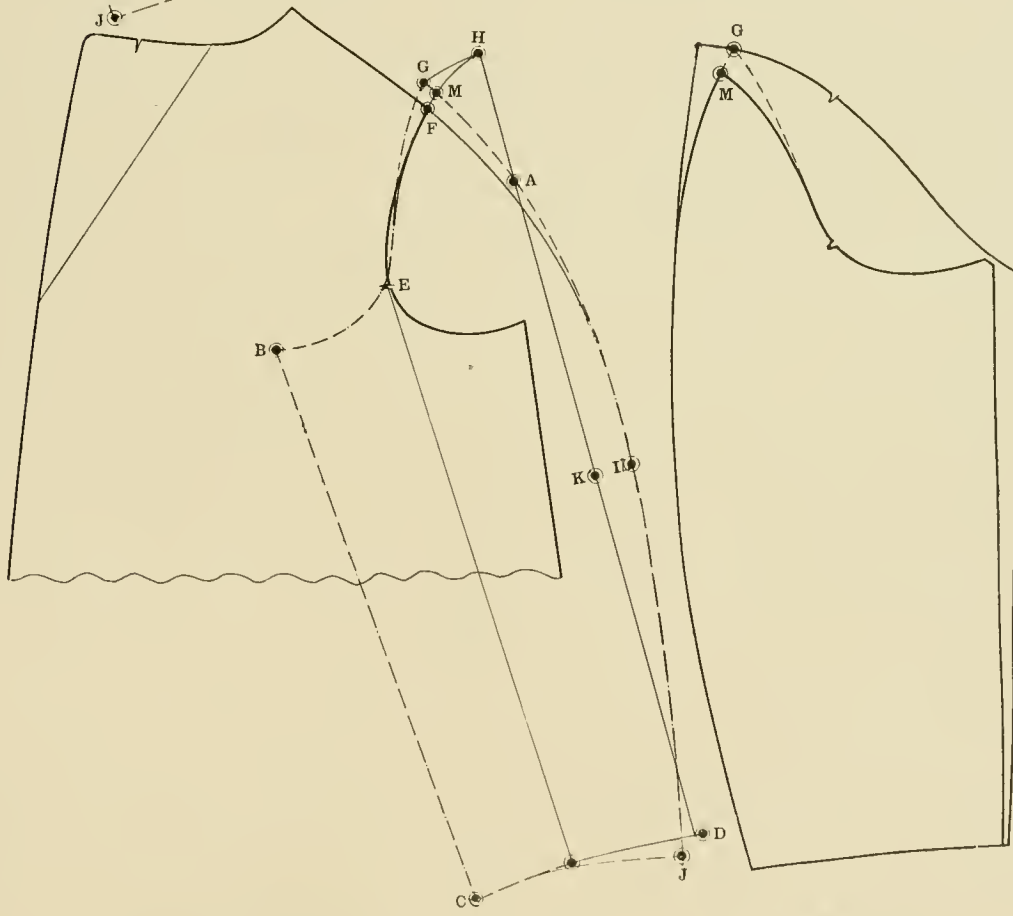
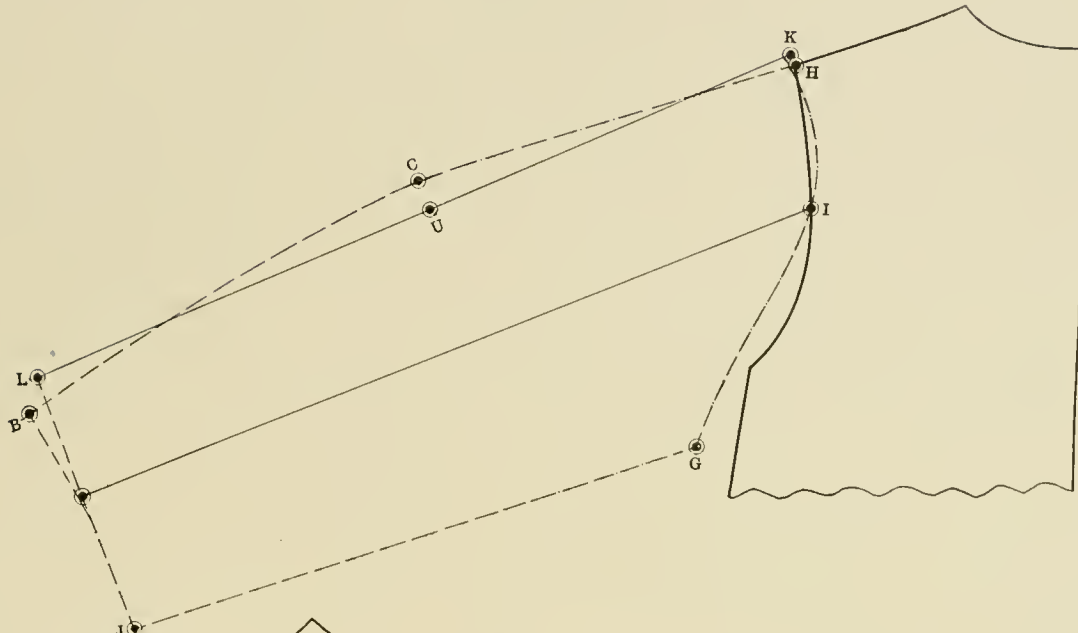

DIAGRAM 99

DIAGRAM 100

## DIAGRAM 101

## INVERNESS.

The measurements as taken over the waistcoat are as follows:

Scye depth .....	9 inches	Blade .....	12½ inches
Waist length .....	16½ inches	Breast .....	36 inches
Strap .....	12 inches	Waist .....	32 inches
Overshoulder .....	17 inches		

Square down and out from A.

From A to B is the scye depth plus  $\frac{1}{4}$  inch; B to C is  $\frac{3}{4}$  inch; A to D is waist length plus  $\frac{3}{4}$  inch; E is full length. These coats are usually cut fairly long. F is half-way between A and C; G is half-way between A and F; square out from G, B, C, D and E.

From D to 2 is  $\frac{3}{4}$  inch; draw a line from F through 2 down; this locates 22; square out from 22; from 1 to 21 is  $1\frac{1}{2}$  inches; 21 to H is  $\frac{1}{2}$  breast; H to I is  $1\frac{1}{2}$  inches; I to J is  $\frac{3}{4}$  inch; K is half-way between 21 and H; K to L is  $3\frac{1}{2}$  inches; square down from L; apply the blade measure from 21 to L which is  $12\frac{1}{2}$  inches and square up; L back to 15 is  $\frac{1}{2}$  inch; square down from 15.

Point M is half-way between 1 and 15; from M to N is  $1\frac{1}{4}$  inches; square up and down from N; this locates point 19; from 19 to 6 is  $1\frac{1}{4}$  inches; 6 back to 20 is  $3\frac{1}{2}$  inches; draw lines from N through 6 down to 7 and from N through 20 down to 18; N to 18 is the same distance as from N to 7.

From A to 8 is  $6\frac{3}{8}$  inches; 8 to 9 is  $1\frac{1}{2}$  inches; draw a line from A to 9; A to 10 is  $\frac{1}{8}$  breast; square up from 10 to locate 11; draw a line from 11 to O; from O back to P is  $1\frac{1}{2}$  inches; N to 4 is 1 inch; 7 to 5 is the same; draw a line from 4 to 5 and shape the back as shown; from 3 to S is  $\frac{1}{2}$  waist; point T is half-way between Q and S; point U is half-way between L and I; draw a line from T through U up.

From A to 11 and L to V is the strap measure plus 1 inch; draw a line from V to O; from V to 34 is the same distance as from 11 to P; L to 23 is  $3\frac{1}{2}$  inches; square back from 23; this locates point 24; notch the backpart on line 23-24; square forwards from V by line T-U; V to W is  $\frac{1}{8}$  breast plus  $\frac{1}{2}$  inch; draw a rounding line from W to J; W to X is  $\frac{1}{8}$  breast; V to Y is  $\frac{1}{8}$  breast; draw a line from Y to X and shape the gorge.

From J to 12 is  $13\frac{1}{4}$  inches; S to 13 is the same; Q to R is  $1\frac{1}{4}$  inches; square down from 13 by line R-13; this locates 16; 16 to 17 is  $\frac{1}{8}$  breast; shape the front edge and bottom of forepart.

## THE CAPE.

Extend the breast line back to 25; from L to 30 is the sleeve length plus  $\frac{3}{4}$  inch; sweep from 30 forwards to 28 and backwards to 25 pivoting at V; add from 28 to 29, 1 inch; from 34 to Z is  $\frac{3}{4}$  inch; shape the back from 25 through P and Z to V. If the cape is to meet in front, it should be cut off as at X-J-S-28, but if it is to button, add from X to 31,  $\frac{3}{4}$  inch, J to 32 and S to 33 the same and shape as per broken line; point 27 is 3 inches from point 25; this is to be a small open vent.

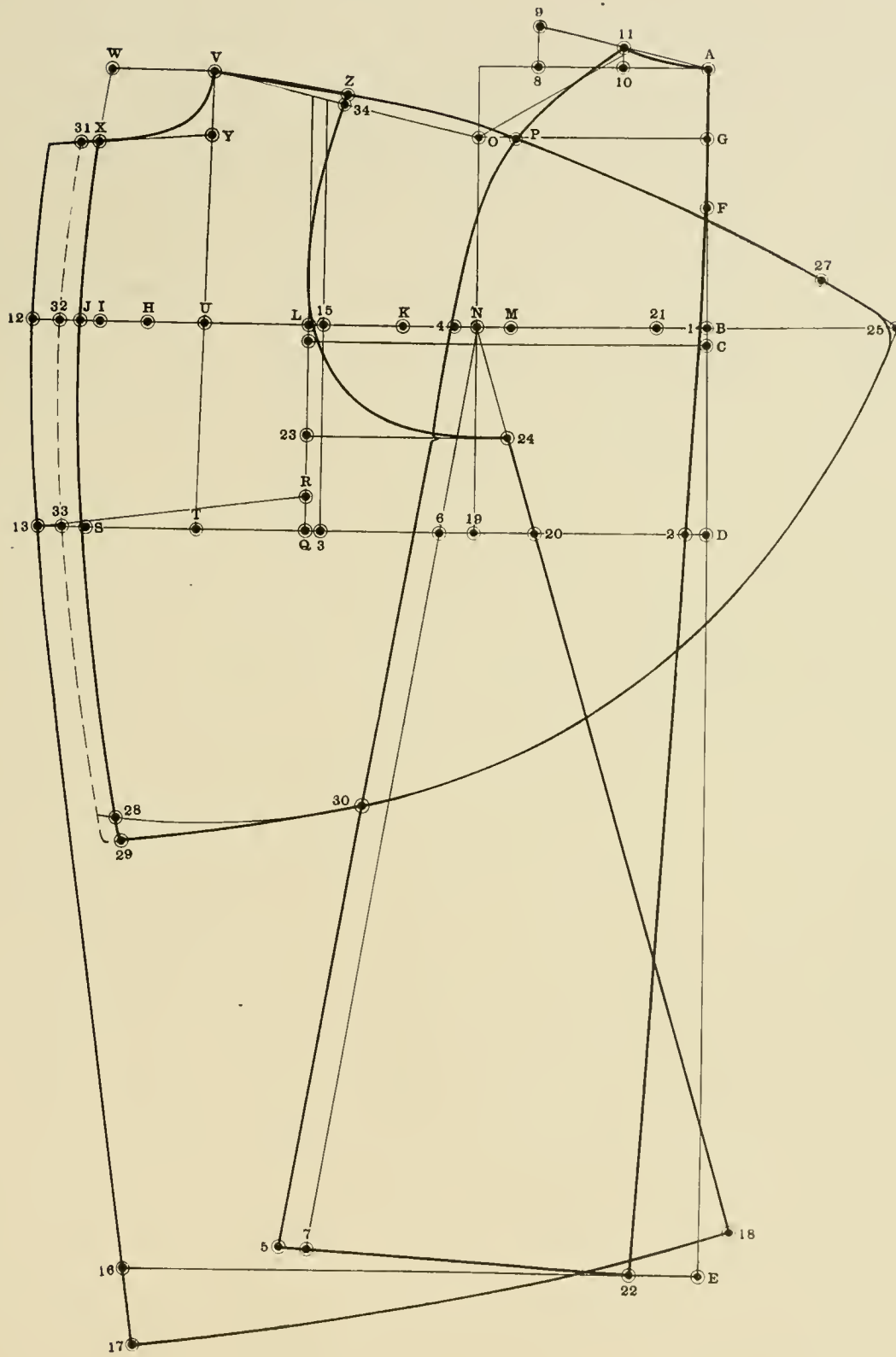

DIAGRAM 101

## DIAGRAM 102

## SQUARE SHOULDERED INVERNESS.

The measurements are the same as in diagram 101.

Square down and out from A.

From A to B is the scye depth plus  $\frac{1}{4}$  inch; B to C is  $\frac{3}{4}$  inch; A to D is waist length plus  $\frac{3}{4}$  inch; E is full length; F is halfway between A and C; G is halfway between A and F; square out from G, B, C, D and E.

From D to 2 is  $\frac{3}{4}$  inch; draw a line from F through 2 down; this locates 22; square out from 22; from 1 to 21 is  $1\frac{1}{2}$  inches; 21 to H is  $\frac{1}{2}$  breast; H to I is  $1\frac{1}{2}$  inches; I to J is  $\frac{3}{4}$  inch; K is halfway between 21 and H; K to L is  $3\frac{1}{2}$  inches; square down from L to locate Q; apply the blade measure from 21 to L and square up; from L back to 15 is  $\frac{1}{2}$  inch; square up and down from 15.

Point M is halfway between 1 and 15; M to N is  $\frac{1}{4}$  inches; square up and down from N; this locates O-19; from 19 to 6 is  $1\frac{1}{4}$  inches; 6 to 20 is  $3\frac{1}{2}$  inches; draw lines from N through 6 to 7 and from N through 20 down; from N to 18 is the same distance as N to 7.

From A to 8 is  $6\frac{3}{8}$  inches; 8 to 9 is  $1\frac{1}{2}$  inches; draw a line from A to 9; A to 10 is  $\frac{1}{2}$  breast; square up from 10 to locate 11; draw a line from 11 to O; now add from N to 1, 1 inch and from 7 to 5 the same and shape the back.

## THE FOREPART.

From 3 to S is  $\frac{1}{2}$  waist; point T is halfway between Q and S; point U is halfway between L and I; draw a line from T through U up; from A to 11 and L to V is the strap measure plus 1 inch; draw a line from V to O; V to Z is  $\frac{3}{8}$  inch less than 11 to O; L to 23 is  $3\frac{1}{2}$  inches; square back from 23; shape the shoulder and armseye as shown; notch the back on line 23-21.

Square forwards from V by line T-U; V to W is  $\frac{1}{2}$  breast plus  $\frac{1}{2}$  inch; draw a rounding line from W through J and S; from W to X is  $\frac{1}{2}$  breast; V to Y is  $\frac{1}{8}$  breast; draw a line from Y through X and shape the gorge; from J to 12 is  $1\frac{3}{4}$  inches; S to 13 is the same; from 3 to R is  $1\frac{1}{4}$  inches; square down from 13 by line R-13; this locates 16; from 16 to 17 is  $\frac{1}{8}$  breast; shape the front edge and bottom of forepart.

The cape is made as follows: extend the breast line to 25; from L to 30 is the sleeve length plus  $\frac{3}{4}$  inch; sweep from 30 forwards to 28 and backwards to 25 pivoting at V; from 28 to 29 is 1 inch; shape the bottom of the cape as shown; from Z to 26 is  $\frac{1}{4}$  breast; sweep from Z to 27 pivoting at 26; from Z to 27 is  $1\frac{1}{2}$  inches; draw a line from 27 to 25; shape the V of the cape as from Z to 26 and the side of the cape from 25 through 27 to 26, adding  $\frac{3}{4}$  inch round to line 25-27.

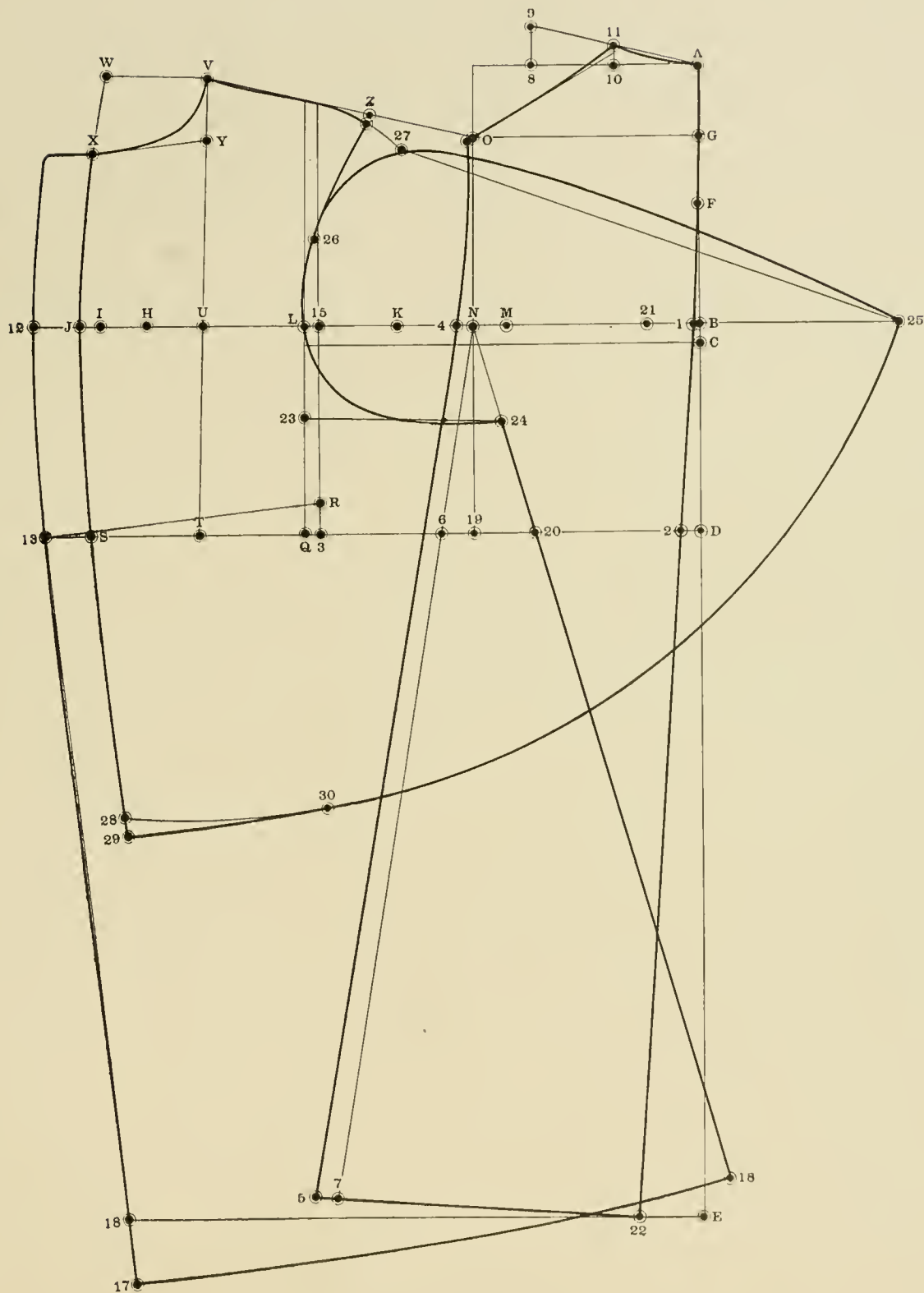

DIAGRAM 102

### DIAGRAM 103

#### SHOULDER CAPE.

Select an overcoat pattern to correspond with the breast measurements required and proceed as follows: mark the backpart pattern on a piece of paper at A, B, C, D and G; from D to E is  $\frac{5}{8}$  inch; G to F is 2 inches; G to H is  $\frac{1}{8}$  breast; from B to J is  $\frac{1}{2}$  breast; J to L is  $\frac{1}{3}$  breast; L to I is  $2\frac{1}{4}$  inches; draw a line from H through I; sweep from C to K pivoting at E; shape the back of the cape as shown, flattening the bottom about  $\frac{1}{2}$  inch.

---

### DIAGRAM 104

#### THE FOREPART.

Place the forepart pattern of the overcoat on a piece of paper and mark around as shown; from A to B is  $\frac{5}{8}$  inch; C to D is the same distance as G to F on the backpart, in this case 2 inches; from D to E is  $\frac{1}{2}$  inch; draw a line from E to G parallel with the armhole; point G is 4 inches from E; sweep from E to F pivoting at G; from E to F is  $1\frac{3}{4}$  inches; from N to I is  $\frac{1}{3}$  breast; point J is  $1\frac{3}{4}$  inches from the front edge; point H is the same.

From J to K is  $\frac{1}{2}$  of the full breast; draw a line from I through K down; from B to E is  $\frac{1}{4}$  inch less than E to F on the backpart; from F to L is the same distance as from F to K on the backpart; sweep from L to M pivoting at A; flatten the bottom of the cape about  $\frac{3}{4}$  inch.

DIAGRAM 103

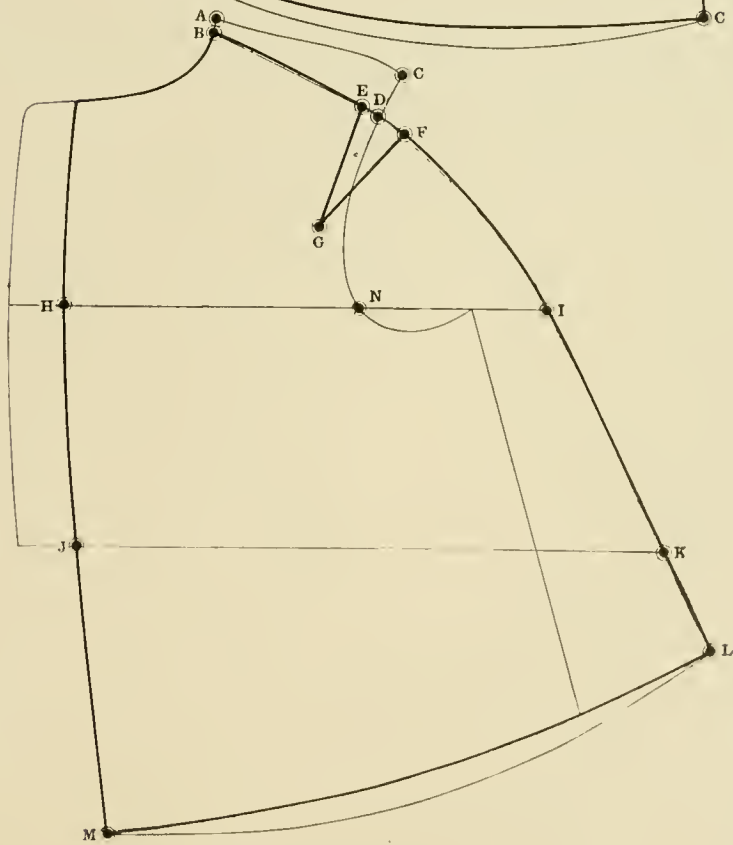
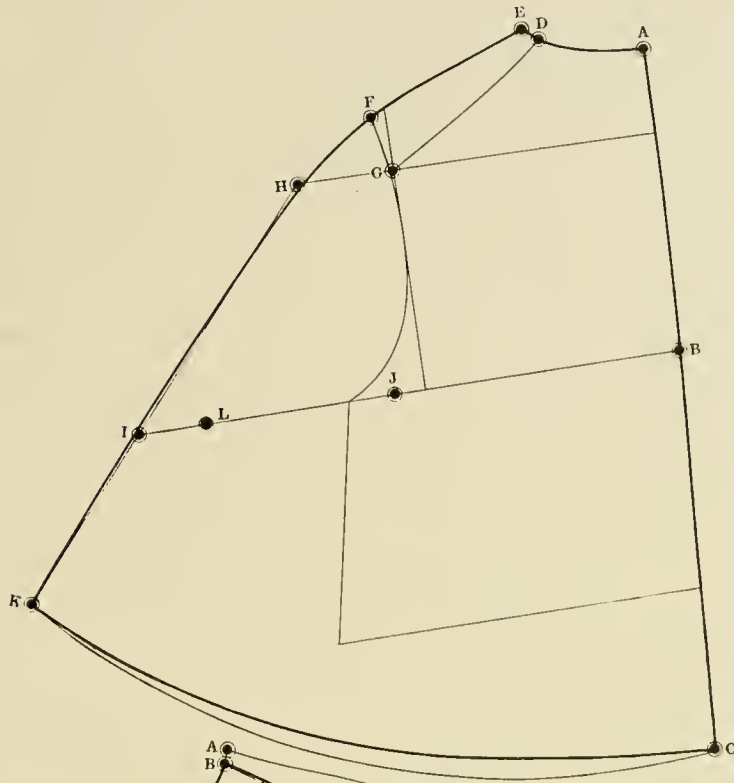

DIAGRAM 104

## DIAGRAM 105

The backpart and forepart, after they are cut out are to be placed together as at A and the bottom straightened if necessary.



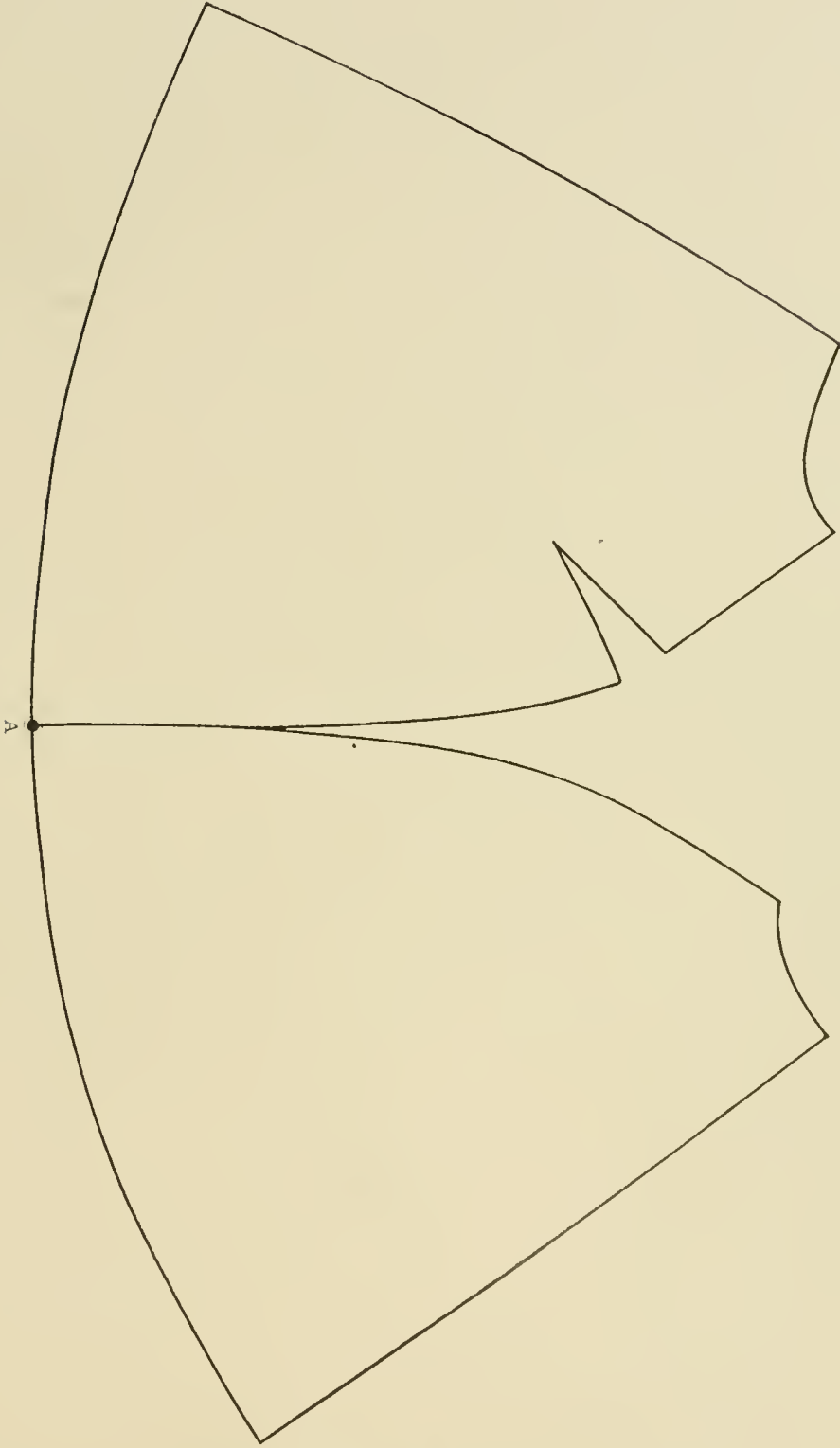

DIAGRAM 105

## DIAGRAM 106

## SPANISH CAPE.

Select an overcoat pattern to correspond with the breast measurement desired and proceed as follows: place the back shoulder alongside of the front shoulder as shown at A-B-C and mark the front and back pattern as shown. Draw a line from D to E; from D to F is  $\frac{1}{8}$  breast; place the square to line D-E and square down from F; measure the length of the cape from D to I; see what difference there is, if any, between that and the overcoat length.

Reduce or increase the back from J to K the same amount as has been reduced or increased from H to I; reduce or increase the front part from O to P the same amount as has been reduced or increased from J to K; M to I is the same distance as O to P; measure the distance from A to K and make the distance from A to G the same; sweep from G forwards to P and backwards to K pivoting at A; reshape the bottom and finish.

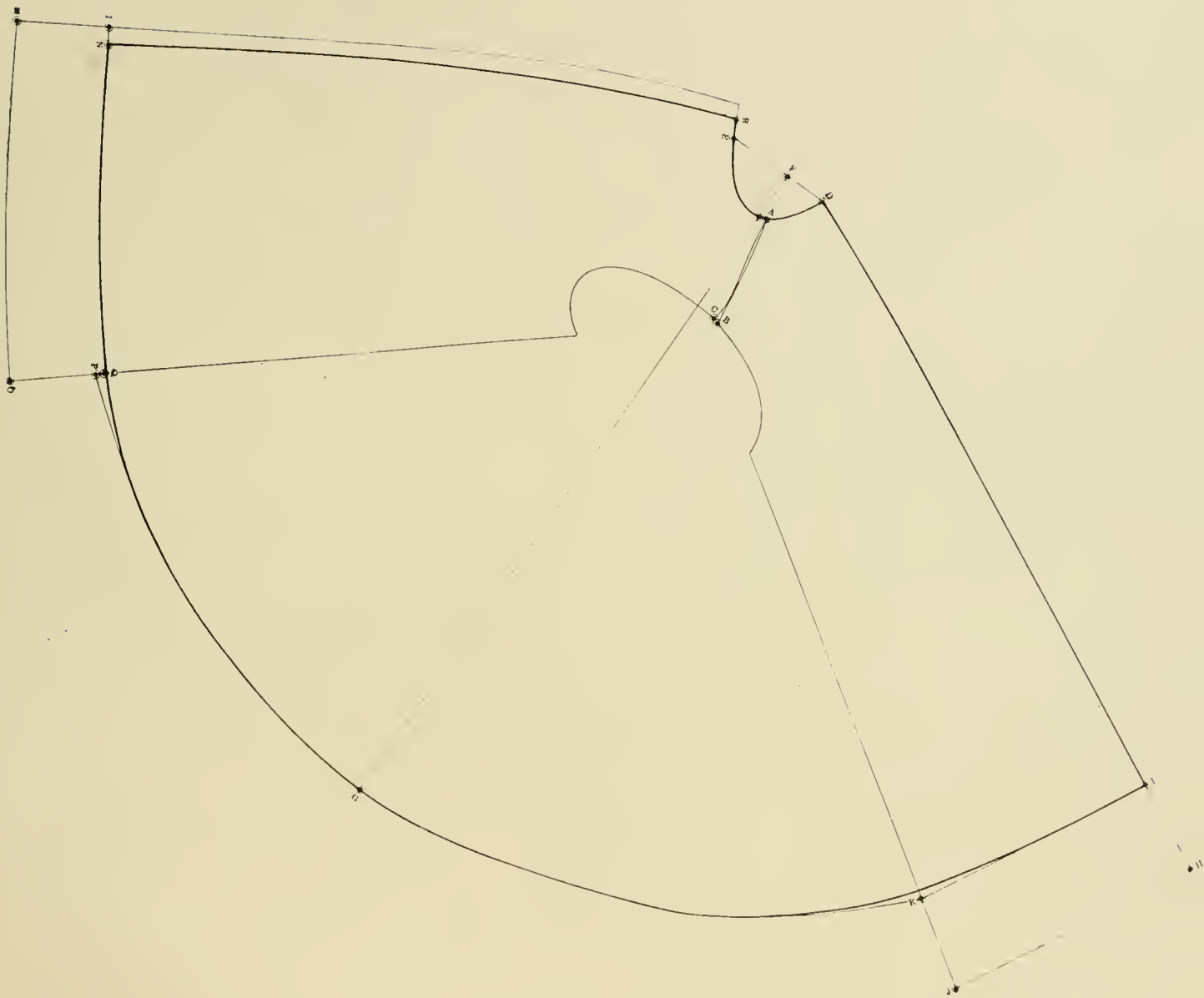

DIAGRAM 106

DIAGRAM 107  
MILITARY CAPE.

Select an overcoat pattern to correspond with the breast measure desired and proceed as follows: place the forepart and backpart into a square as shown in this diagram, so that both shoulders touch at Q; apply the length from D to F and whatever difference there is between F and B, make the same distance between G and H, K and L, I and J; add to M-N  $\frac{1}{2}$  or  $\frac{3}{4}$  inch and from Q to R the same; reduce the forepart from O to E the same amount as has been increased from M to N; draw a straight line from O to N; point P is half-way between M and O.

Sweep from H to L pivoting at P; point T is halfway between L and H; draw a line from R to T; from T to S is 5 inches; this distance may be made more or less according to the amount of drapery desired; draw a line from S to R; shape the front and back parts as shown, *i. e.*, the backpart from N through R to T and the front part from E through R to S; after both parts have been cut out, place them together at point S-T and fill in slightly to make the circle complete.

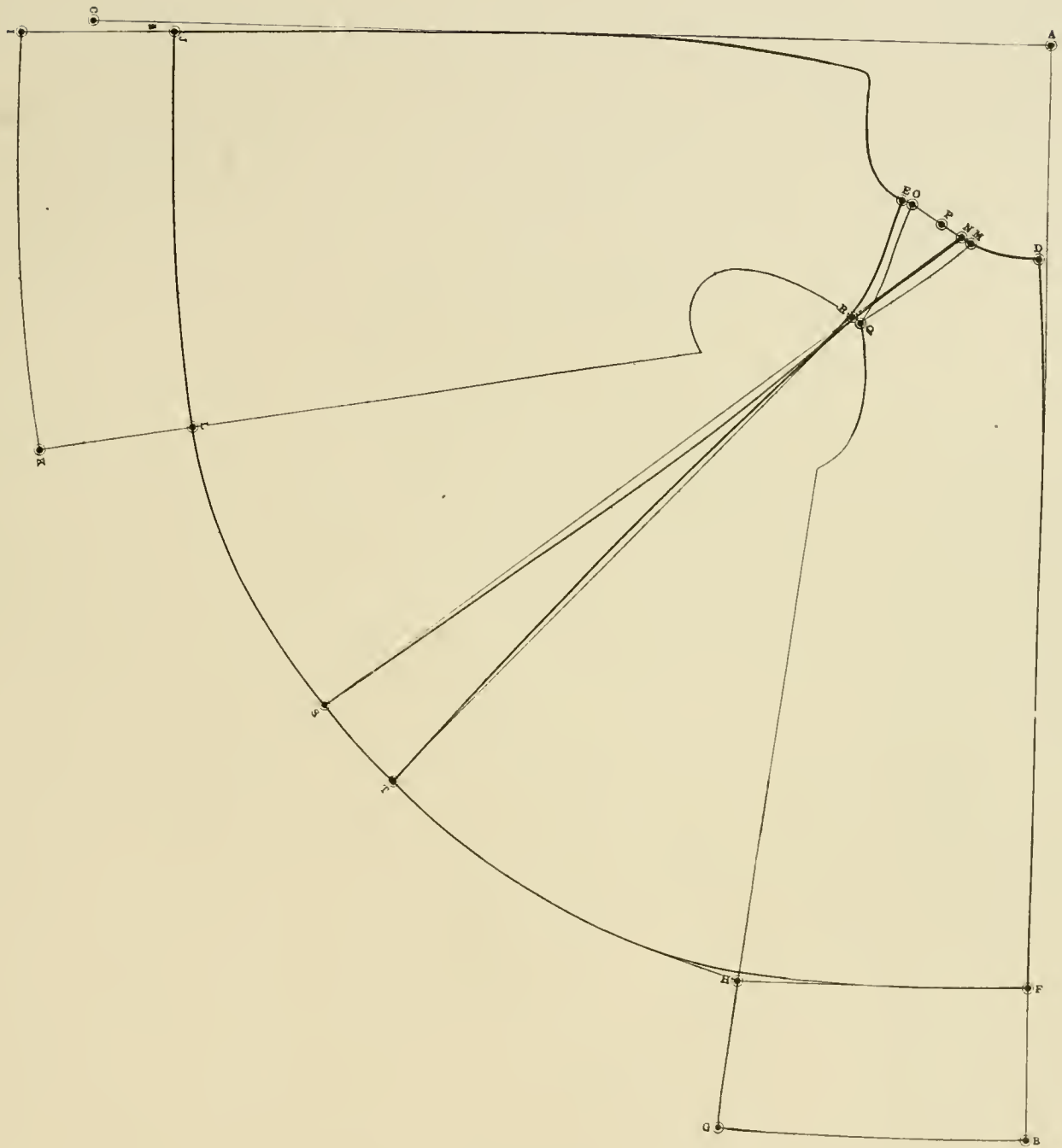

DIAGRAM 107

## DIAGRAMS 108 &amp; 109

## A HOOD.

The hood is made as follows: select an overcoat pattern of the size desired; place the backpart on a sheet of paper and mark around it as from C to A, A to U, and U to S; line B is the breast line; from B to L is  $\frac{1}{2}$  breast; L to M is  $2\frac{3}{4}$  inches; now place the forepart to overlap the backpart  $\frac{1}{2}$  inch from S to 4.

Make the opening between U and 25, 1 inch; now mark around the shoulder and gorge of the forepart as from 4 to 25 and from 25 to 21; point 21 is where the lapel crease is; draw a line from 21 to M; from A to C is the length of hood desired; draw a line from C to M; shape the hood, adding about an inch rounding over the line 21-M.

Diagram 109 is the hood after it is folded into place. After the hood has been folded, as is herein shown, go in from A to B, 1 inch; round the center seam away as to line B; stretch out the fold and shrink in the center seam as indicated.

DIAGRAM 108

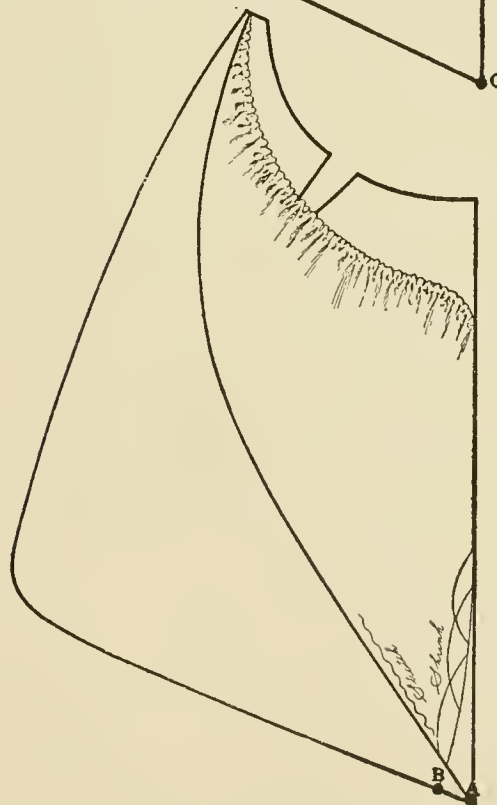
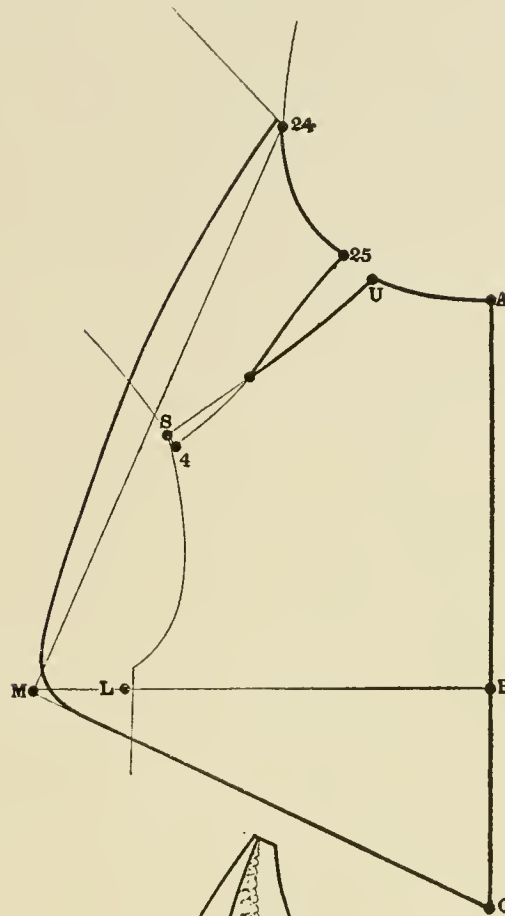

DIAGRAM 109

## DIAGRAM 110

## NAVAL OFFICER'S BLOUSE.

(This coat is also worn by bicycle policemen.)

The measurements are as follows:

Syce depth .....	9 $\frac{3}{8}$ inches	Blade .....	13 inches
Waist .....	17 inches	Breast .....	38 inches
Full length .....	30 inches	Waist .....	34 inches
Strap .....	12 $\frac{1}{2}$ inches	Hip .....	40 inches
Overshoulder .....	17 $\frac{5}{8}$ inches		

Square down and out from A.

From A to B is syce depth plus  $\frac{1}{4}$  inch; C is waist length; C to D is 6 inches; A to E is full length; F is halfway between A and B; G is halfway between A and F; square out from G, F, B, C, D and E.

From C to 2 is 1 inch; E to 22 is  $\frac{1}{2}$  inch; draw a line from F to 2 and 2 to 22; from 1 to H is  $\frac{1}{2}$  breast; H to I is 1 $\frac{3}{4}$  inches; I to J is  $\frac{3}{4}$  inch; K is halfway between 1 and H; K to L is 3 $\frac{1}{2}$  inches; square down from L to locate Q; apply the blade measure from 1 to L which is 13 inches and square up; 4 is halfway between 1 and L; from 4 to N is 1 $\frac{1}{4}$  inches; square up from N; this locates point R-O.

From R to P is 1 inch; from A to 8 is 6 $\frac{3}{8}$  inches; 8 to 9 is 1 $\frac{1}{2}$  inches; draw a line from A to 9; A to 10 is  $\frac{1}{2}$  breast; square up from 10 to locate 11; draw a line from  $\frac{1}{4}$  inch below 11 to O; from 2 to 5 is  $\frac{1}{4}$  waist; square down from 5 and shape the back.

## THE FOREPART.

From Q to S is  $\frac{1}{2}$  waist; point T is halfway between Q and S; point U is halfway between L and I; draw a line from T through U up; from A to 11 and L to V is the strap measure plus  $\frac{3}{4}$  inch; draw a line from V to O; V to Z is  $\frac{3}{8}$  inch less than the back shoulder width; shape the shoulder and armseye.

Square forwards from V by line T-U; V to 23 is  $\frac{1}{2}$  breast; 23 to W is  $\frac{1}{2}$  inch; shape the front edge from W through J and S down; from S to 14 is 2 $\frac{1}{2}$  inches; 6 to 15 is the same; from 32 to 3 and 15 to 20 is the seat measure; from 5 to 2 and 14 to 31 is the waist measure; point 18 is halfway between 5 and 31; draw a line from 18 through 20 down; from 18 to 21 is the same distance as from 5 to 7; shape the side of forepart; from 16 to 17 is  $\frac{1}{8}$  breast; shape the bottom of forepart.

Point 27 is halfway between N and L; square down from 27; take out between 28 and 29 the surplus amount from between 18 and 31; the broken line as at 24-25 and 26-33 is the facing; from X to 26 and 6 to 33 is 1 $\frac{1}{2}$  inches each, and this is left on the facing for a button stand.

The collar for this coat is a standing collar and is made the same as shown on Diagrams 47 and 48.



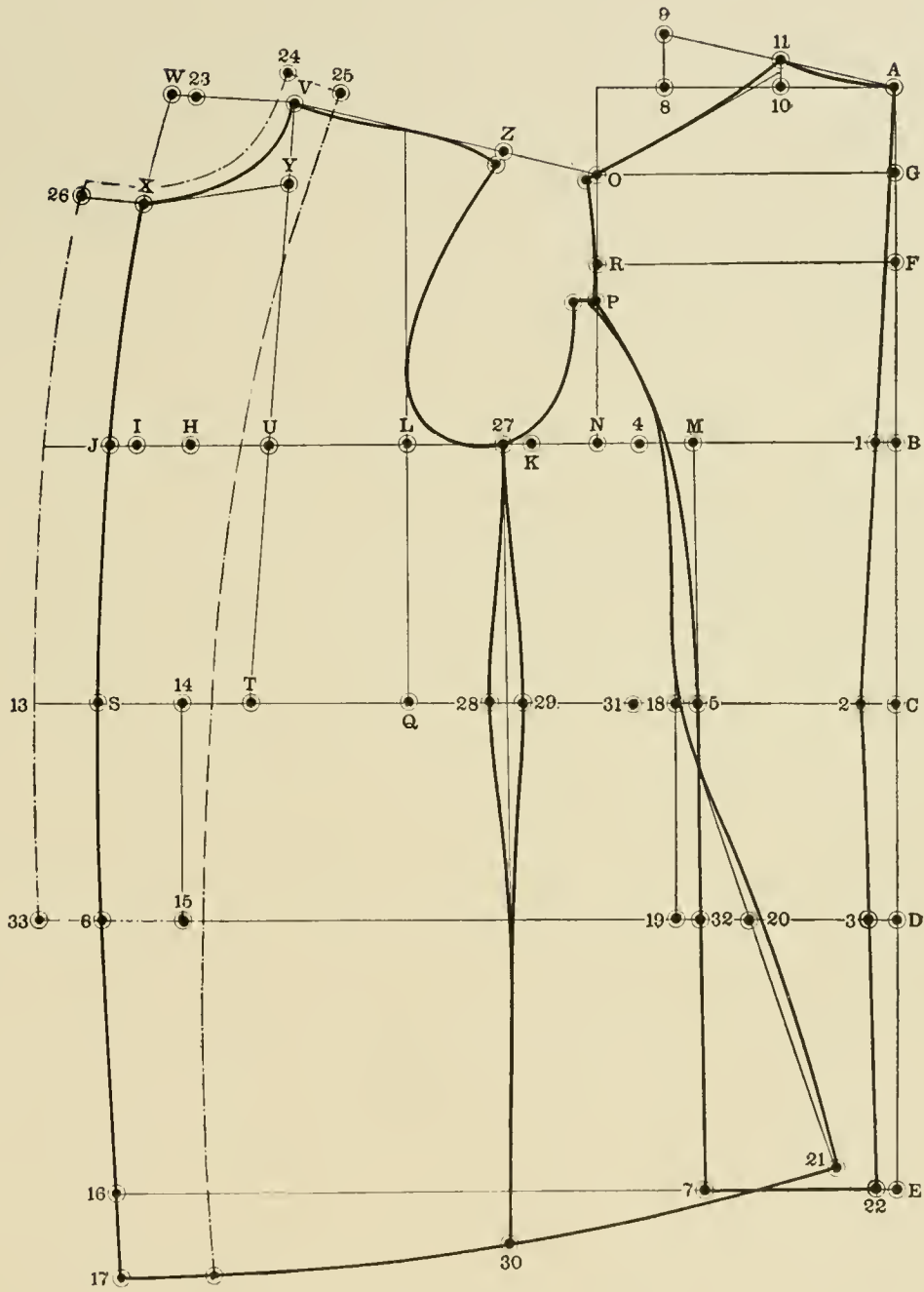

DIAGRAM 110

## DIAGRAM 111

## COACHMAN'S OR GROOM'S FROCK UNDERCOAT.

The measurements are as follows:

Indentation .....	1½ inches	Strap .....	12¾ inches
Scye depth .....	9½ inches	Overshoulder .....	18 inches
Waist length .....	16¾ inches	Blade .....	13¼ inches
Fashionable waist length .....	18½ inches	Breast .....	39 inches
Full length .....	39 inches	Waist .....	35½ inches

Square down and out from A.

From A to B is the scye depth plus ¼ inch; C is natural waist length; D is fashionable waist length; E is full length; F is halfway between A and B; G is halfway between A and F; square out from G, F, B, C, D and E.

From C to R is ½ indentation; draw a straight line from A through R to Q and square down; from H to I is ½ breast; I to J is 1½ inches; J to 11 is ¾ inch; K is halfway between H and I; K to L is 3½ inches; square down from L to locate M; apply the blade measure from H to L which is 13¼ inches and square up; N is halfway between H and L; N to O is 1¼ inches.

From A to 24 is the same distance as from H to O; draw a line from O to 24; A to T is 6¾ inches; T to U is 1½ inches; draw a line from A to U; A to V is ⅙ breast; square up from V to locate W; draw a line from ¼ inch below W to P; from Q to S is ⅛ breast plus ¼ inch; square down from S and shape the back.

From X to Y is 1¼ inches; square down from Y; 1 to 2 is ¾ inch; point 3 is ½ inch above the waist line; point Z is halfway between Y and M; shape the sidebody.

## THE FOREPART.

From M to 4 is ½ waist; square down from 4; this locates 11; from 11 to 12 is ½ inch less than ⅙ breast; point 5 is halfway between M and 4; point 6 is halfway between L and J; draw a line from 5 through 6 up; from A to W and L to 7 is the strap measure plus ¾ inch; draw a line from 7 to P; from 7 to 23 is ⅜ inch less than the back shoulder width; shape the shoulder and armscye.

Square forwards from 7 by line 5-6; from 7 to 9 is ⅙ breast plus ¼ inch; 7 to 8 is ⅙ breast; square forwards from 8 and shape the gorge. These coats are cut to button high up and are made with a short lapel and fronts close with five buttons; from 14 to 15 is 1¼ inches; 4 to 13 is the same; shape the front edge.

From 4 back to 27 is 2¼ inches; from Z to Y, X to R and 27 to 21 is the waist measure net; shape the side and bottom of forepart.

## THE SKIRT.

From Y to 25 is 9 inches; 25 to 26 is 1½ inches; draw a line from 22 through 26 down; from 22 to 19 is ¼ inch more than from S to 17; from 12 to 18 is the same distance as 22 to 19; square down from 20 by the waist line; from 3 to 16 is ⅝ inch; shape the skirt and finish, rounding the latter ⅝ inch at 26.

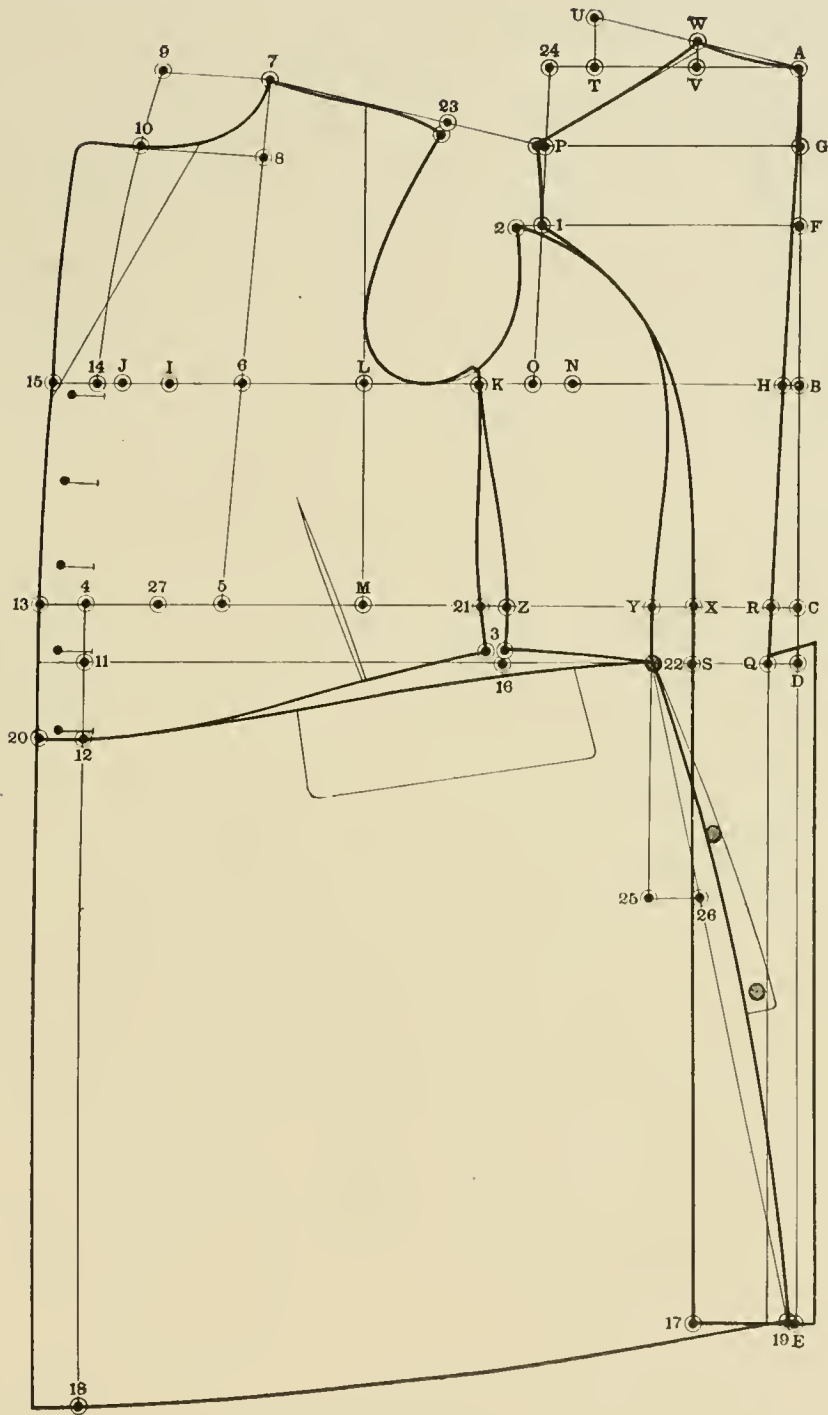

DIAGRAM 111

DIAGRAM 112  
COACHMAN'S FROCK OVERCOAT.

The measurements as taken over the waistcoat are as follows:

Seye depth ..... $9\frac{3}{4}$ inches	Strap ..... 13 inches
Natural waist length ..... 17 inches	Overshoulder ..... $18\frac{1}{4}$ inches
Fashionable waist ..... $18\frac{3}{4}$ inches	Blade ..... $13\frac{1}{2}$ inches
Full length ..... 46 inches	Breast ..... 40 inches
(or whatever style calls for.)	Waist ..... 37 inches

Square down and out from A.

From A to B is the seye depth plus  $\frac{1}{4}$  inch; B to 30 is  $\frac{3}{4}$  inch; A to C is natural waist length; D is fashionable waist length; E is full length; F is halfway between A and 30; G is halfway between A and F; square out from G, F, B, 30, C, D and E.

From C to R is  $\frac{3}{4}$  inch; draw a line from A through R to Q; from H to 13 is  $1\frac{1}{2}$  inches; 13 to I is  $\frac{1}{2}$  breast; I to J is  $1\frac{1}{2}$  inches; J to 22 is 1 inch; K is halfway between 13 and I; K to L is  $3\frac{1}{2}$  inches; square down from L to locate M; apply the blade measure from 13 to L which is  $13\frac{1}{2}$  inches and square up; L back to 31 is  $\frac{1}{2}$  inch; square up and down from 31; N is halfway between H and 31; N to O is  $1\frac{1}{4}$  inches.

From A to 28 is the same distance as H to O; draw a line from O to 28; A to T is  $6\frac{3}{8}$  inches; T to U is  $1\frac{1}{2}$  inches; draw a line from A to U; A to V is  $\frac{1}{8}$  breast; square up from V to locate W; draw a line from  $\frac{1}{4}$  inch below W to P; from Q to S is  $\frac{1}{8}$  breast plus  $\frac{1}{4}$  inch; square down from S and shape the back.

**THE SIDEBODY.**

From X to Y is  $1\frac{1}{4}$  inches; 1 to 2 is  $\frac{3}{4}$  inch; O to 33 is  $\frac{1}{2}$  breast; point Z is halfway between Y and 40; point 3 is  $\frac{1}{2}$  inch above the waistline; shape the sidebody.

**THE FOREPART.**

From M to 4 is  $\frac{1}{2}$  waist; square down from 4; this locates 11; from 11 to 14 is  $\frac{1}{2}$  inch less than  $\frac{1}{8}$  breast; point 5 is halfway between M and 4; point 6 is halfway between L and J; draw a line from 5 through 6 up; from A to W and L to 7 is the strap measure plus  $\frac{3}{4}$  inch; draw a line from 7 to P; 7 to 23 is  $\frac{3}{8}$  inch less than the back shoulder width; shape the shoulder and armseye.

Square forwards from 7 by line 5-6; from 7 to 9 is  $\frac{1}{8}$  breast plus  $\frac{3}{4}$  inch; add  $\frac{1}{4}$  inch in front of 4 for a seam and shape the front edge from 9 through 22 down to 14; from 9 to 10 is  $\frac{1}{8}$  breast; 7 to 8 is  $\frac{1}{8}$  breast; draw a line from 8 to 10 and shape the gorge; 4 back to 17 is  $2\frac{1}{4}$  inches; R to 29 is the same as from H to 13; from Z to Y, X to 29 and 17 to 21 is the waist measure net; shape the side of forepart.

**THE REVER.**

Draw a straight line from 14 up to 36; sweep from 10 to 36 pivoting at 14; sweep from 14 forwards to 20, and backwards pivoting at 36; the rever width from 14 to 20 is 3 inches; from 36 back to 37 is  $\frac{1}{2}$  inch; round the rever slightly down from 37; 37 to 38 is  $4\frac{1}{2}$  inches; finish the rever as shown.

**THE SKIRT.**

Draw a straight line from 6 into the sweep at 14; this locates point 12; from 6 to 24 is  $1\frac{1}{4}$  inches; draw a line from 12 to 24 and square down; 24 to 25 is 9 inches; 25 to 26 is  $1\frac{1}{2}$  inches; draw a line from 24 through 26 down; from 24 to 19 is  $\frac{1}{4}$  inch more than from S to 18; 14 to 15 is the same distance as 24 to 19; square down from 20 by the waist line; finish the skirt as shown, rounding it  $\frac{5}{8}$  inch at 26.

**THE COLLAR.**

A Prussian collar is to be worn with this coat, which collar is made as follows: draw a straight line from 10 through 7; 10 to 39 is  $\frac{1}{2}$  the size of the shirt collar; the proportion shirt collar for a man of 40 breast would be  $15\frac{1}{2}$  inches, therefore the distance from 10 to 39 is  $7\frac{3}{4}$  inches.

Point 41 to 42 is 1 inch; shape the collar from 39 through 42 to 10; from 39 back to 45 is the same distance as from A to W on the backpart; place the square to points 39-45 and square up; 45 to 46 is  $1\frac{1}{4}$  inches; 46 to 47 is  $\frac{3}{4}$  inch; 39 to 43 is  $1\frac{1}{4}$  inches; 10 to 44 is  $\frac{1}{2}$  inch; shape the collar stand from 43 through 46 to 44; from 43 to 48 is the width of the collar desired; shape the outer leaf of the collar and finish.

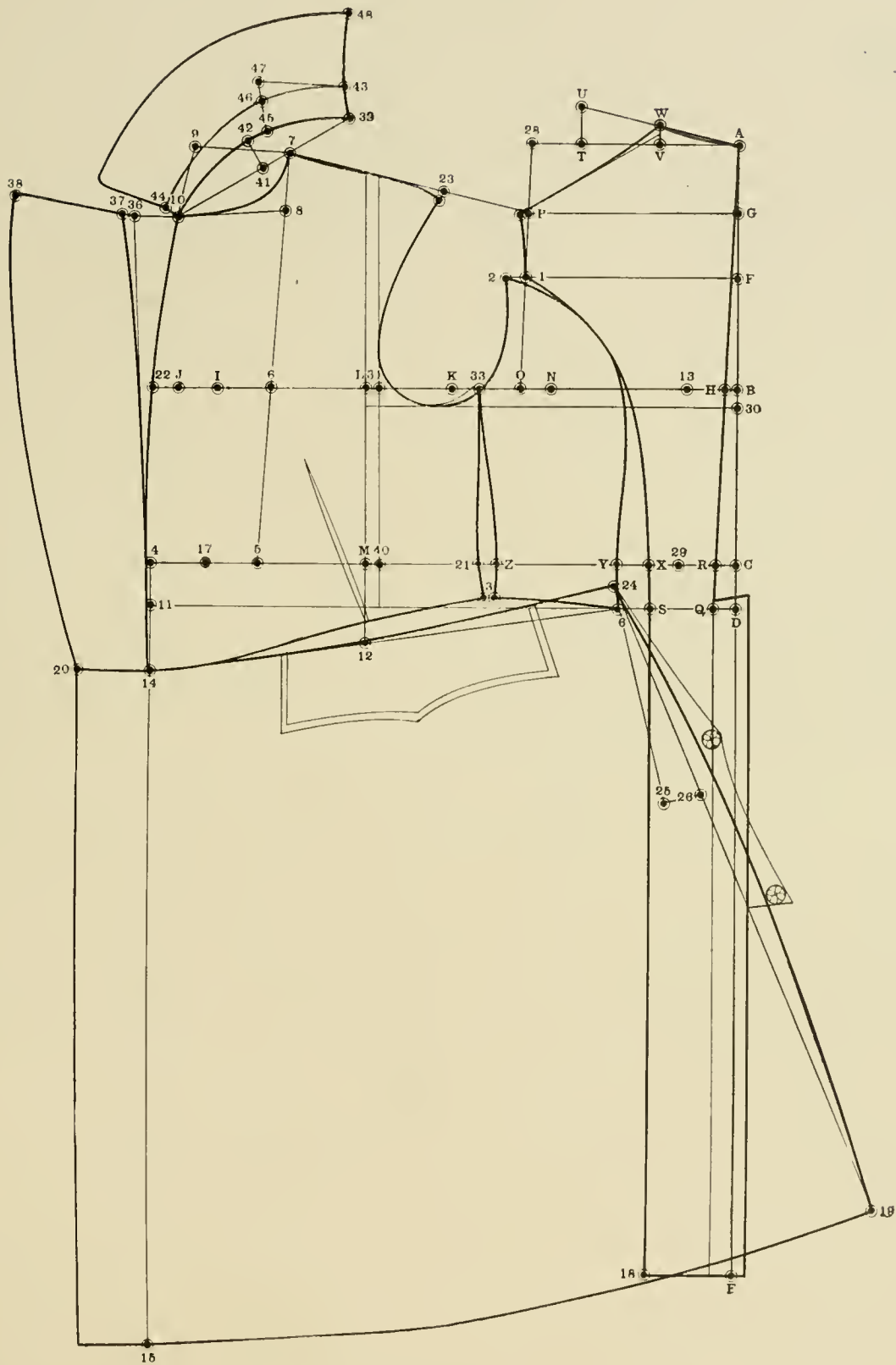

DIAGRAM 112

## DIAGRAM 113.

## FOOTMAN'S OR DOORMAN'S DRESS COAT.

The measurements are as follows:

Indentation . . . . .	1½ inches	Strap . . . . .	12 inches
Seye depth . . . . .	9 inches	Overshoulder . . . . .	17 inches
Natural waist length . . . . .	16½ inches	Blade . . . . .	12½ inches
Fashionable waist length . . . . .	18¼ inches	Breast . . . . .	36 inches
Full length . . . . .	31 inches	Waist . . . . .	32 inches

(or according to the man's height.)

Square down and out from A.

From A to B is the seye depth plus ¼ inch; C is natural waist length; D is fashionable waist length; E is full length; F is halfway between A and B; G is halfway between A and F; square out from G, F, B, C, D and E.

From C to R is ½ indentation; draw a line from A through R to Q and square down; H to I is ½ breast; I to J is 1½ inches; J to K is ¾ inch; K is halfway between H and I; K to L is 3½ inches; square down from L to locate M; apply the blade measure from H to L, which is 12½ inches and square up; N is halfway between H and L; N to O is ¼ inch; from A to 24 is the same distance as from H to O; draw a line from O to 24.

From A to T is 6⅜ inches; T to U is 1½ inches; draw a line from A to U; A to V is ¼ breast; square up from V to locate W; draw a line from ¼ inch below W to P; Q to S is ⅝ breast; square down from S and shape the back.

## THE SIDEBODY.

From X to Y is 1¼ inches; square down from Y; 1 to 2 is ¾ inch; point Z is halfway between Y and M; point 3 is ½ inch above the waistline; shape the sidebody.

## THE FOREPART.

From M to 4 is ½ waist; square down from 4 to locate 11; 11 to 12 is ½ inch less than ¼ breast; point 5 is halfway between M and 4; point 6 is halfway between L and J; draw a line from 5 through 6 up; from A to W and L to 7 is the strap measure plus ¾ inch; draw a line from 7 to P; from 7 to 23 is ⅜ inch less than W to P; shape the shoulder and armseye.

Square forwards from 7 by line 5-6; 7 to 9 is ¼ breast plus ½ inch; 4 back to 13 is 1¼ inches; shape the front edge from 9 through 14 and 13 down to 15; 9 to 10 is ¼ breast; 7 to 8 is ⅝ breast; draw a line from 8 to 10 and shape the gorge; 4 back to 27 is 2 inches; Z to Y, X to R and 27 to 21 is the waist measure net; shape the side and bottom of forepart.

## THE SKIRT.

From Y to 25 is 9 inches; 25 to 26 is 1½ inches; draw a line from 20 through 26 down; 20 to 18 is ¼ inch more than from S to 17; 12 to 28 is the same distance as 20 to 18; draw a line from 18 to 28; shape the skirt as shown, rounding it ⅝ inch at 26.

## THE COLLAR.

Draw a line from 10 through 7; 10 to 19 is two sizes more than the shirt collar; the proportionate size of shirt collar for a man, 36 breast, is 14½ inches, one-half of which is 7¼ inches. The distance therefore from 10 to 19 is 8¼ inches; shape the collar from 19 into the gorge; square up from 19 to 22; 19 to 22 is the height of collar desired; 10 to 16 is the same; finish the collar as shown.

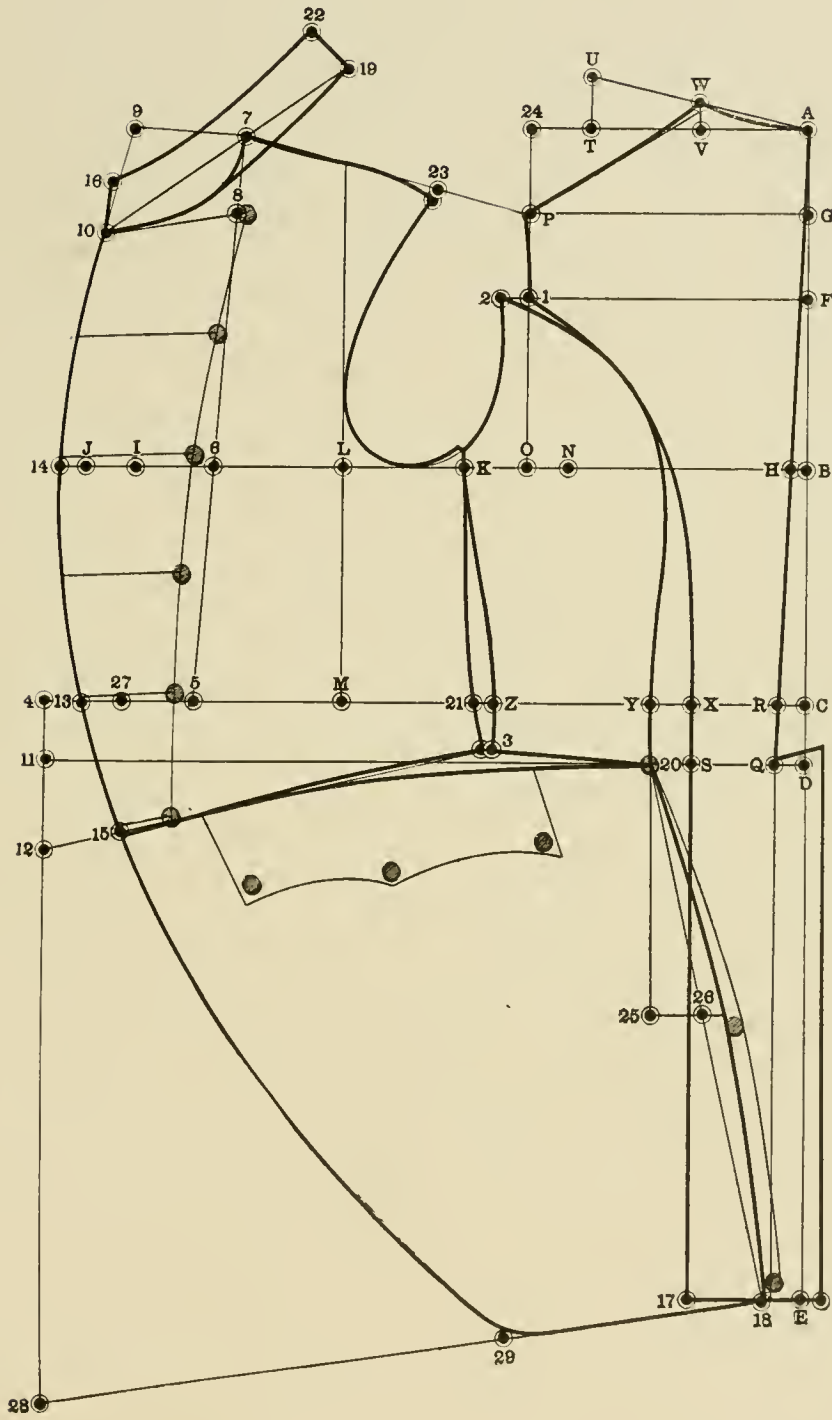

DIAGRAM 113

## DIAGRAM 114

## FOOTMAN'S COATEE.

The measurements are as follows:

Scye depth .....	$9\frac{3}{8}$ inches	Overshoulder .....	$17\frac{5}{8}$ inches
Natural waist .....	$16\frac{3}{4}$ inches	Blade .....	13 inches
Fashionable waist .....	$18\frac{1}{2}$ inches	Breast .....	38 inches
Full length .....	36 inches	Waist .....	34 inches
Strap .....	$12\frac{1}{2}$ inches		

Square down and out from A.

From A to B is the scye depth plus  $\frac{1}{4}$  inch; C is natural waist length; D is fashionable waist length; E is full length; F is halfway between A and B; G is halfway between A and F; square out from G, F, B, C, D and E.

From C to R is  $\frac{1}{2}$  indentation; draw a line from A through R to Q and square down; H to I is  $\frac{1}{2}$  breast; I to J is  $1\frac{1}{2}$  inches; K is halfway between H and I; K to L is  $3\frac{1}{2}$  inches; square down from L to locate M; apply the blade measure from H to L which is 13 inches and square up; N is halfway between H and L; N to O is  $1\frac{1}{4}$  inches; A to 21 is the same distance as H to O; draw a line from O to 21.

From A to T is  $6\frac{3}{8}$  inches; T to U is  $1\frac{1}{2}$  inches; draw a line from A to U; A to V is  $\frac{1}{8}$  breast; square up from V to locate W; draw a line from  $\frac{1}{4}$  inch below W to P; Q to S is  $\frac{1}{8}$  breast; square down from S and shape the back.

## THE SIDEBODY.

From X to Y is  $1\frac{1}{4}$  inches; 1 to 2 is  $\frac{3}{4}$  inch; O to K is  $\frac{1}{2}$  breast; point Z is halfway between Y and M; point 3 is  $\frac{1}{2}$  inch above the waist line; shape the sidebody; M to 4 is  $\frac{1}{2}$  waist; square down from 4 to locate 11; 11 to 12 is  $\frac{1}{2}$  inch less than  $\frac{1}{8}$  breast; point 5 is halfway between M and 4; point 6 is halfway between L and J; draw a line from 5 through 6 up; A to W and L to 7 is the strap measure plus  $\frac{3}{4}$  inch; draw a line from 7 to P; 7 to 23 is  $\frac{3}{8}$  inch less than W to P; shape the shoulder and armseye.

Square forwards from 7 by line 5-6; 7 to 9 is  $\frac{1}{8}$  breast; 4 back to 13 is  $1\frac{1}{4}$  inches; shape the front edge from 9 through J and 13 to 14; 9 to 10 is  $\frac{1}{8}$  breast; 7 to 8 is  $\frac{1}{8}$  breast; draw a line from 8 to 10 and shape the gorge; from 4 back to 27 is 2 inches; from Z to Y, X to R and 27 to 21 is the waist measure net; shape the side and bottom of forepart.

## THE SKIRT.

From Y to 25 is 9 inches; 25 to 26 is  $1\frac{1}{2}$  inches; draw a line from 22 through 26 down; 22 to 19 is  $\frac{1}{4}$  inch more than S to 17; 12 to 18 is the same distance as 22 to 19; draw a line from 18 to 19; point 16 is  $\frac{5}{8}$  inch below point 3. From 15 to 20 is  $1\frac{3}{4}$  inches; from 20 to 24 is  $\frac{1}{3}$  the distance of from 14 to 22; from 19 to 28 is the same distance as from 20 to 24; draw a line from 24 to 28. Cut the rever the same as for any other dress coat.



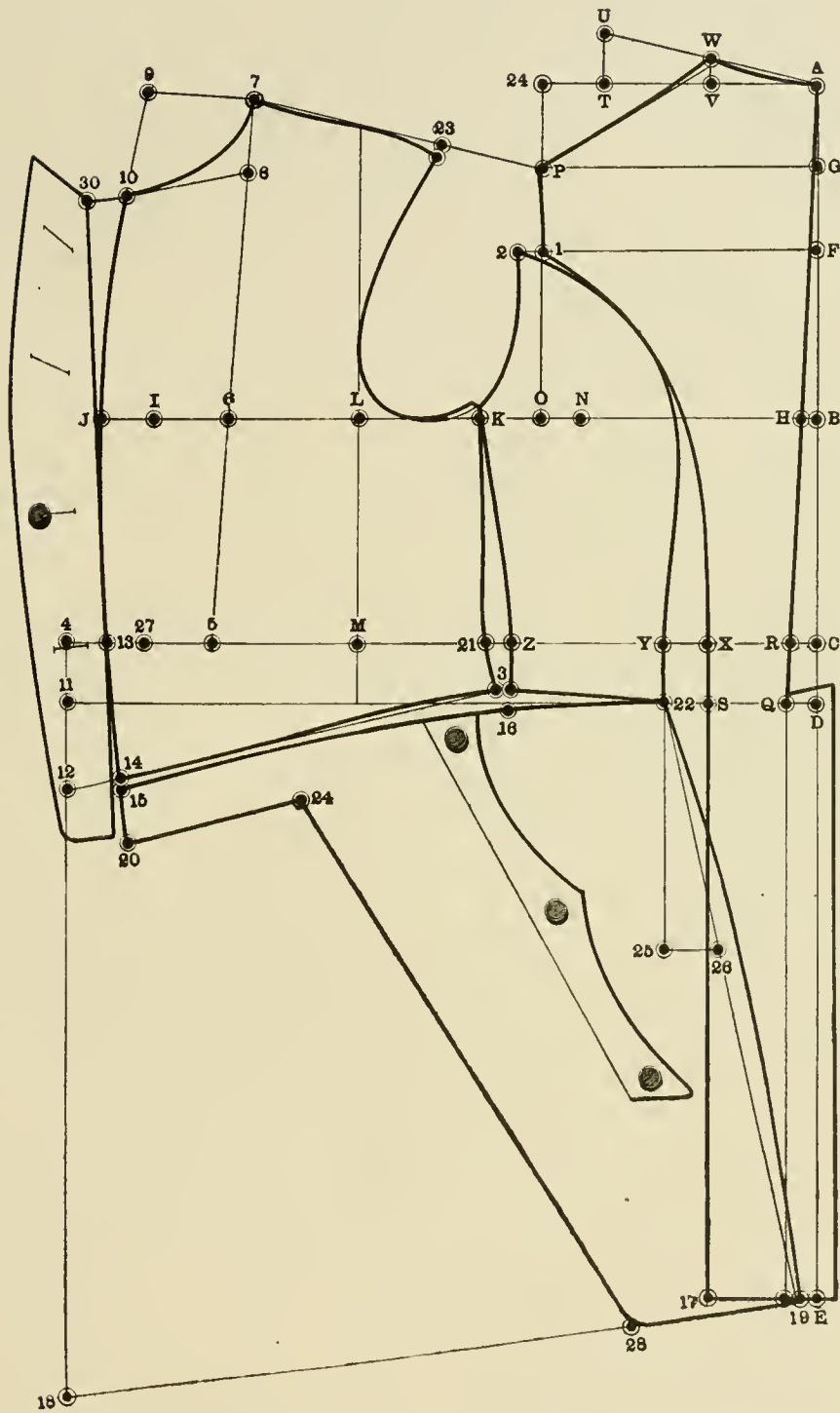

DIAGRAM 114

## DIAGRAM 115

## MESS JACKET.

The measurements are as follows:

Scye depth .....	9 inches	Overshoulder .....	17 inches
Waist length .....	16 inches	Blade .....	12½ inches
Fashionable waist length .....	17¾ inches	Breast .....	36 inches
Full length .....	20 inches	Waist .....	32 inches
Strap .....	12 inches		

Square down and out from A.

From A to B is the scye depth plus ¼ inch; C is waist length; D is fashionable waist length; E is full length; F is halfway between A and B; G is halfway between A and F; square out from G, F, B, C, D and E.

From C to R is ½ indentation; draw a straight line from A to R and square down; from H to I is ½ breast; I to J is 1½ inches; J to 14 is ¾ inch; K is halfway between H and I; K to L is 3½ inches; square down from L to locate M; apply the blade measure from H to L, which is 12½ inches and square up; N is halfway between H and L; N to O is ¼ inches.

From A to 24 is the same distance as H to O; draw a line from O to 24; from A to T is 6¾ inches; T to U is 1½ inches; draw a line from A to U; A to V is ½ breast; square up from V to locate W; draw a line from ¼ inch below W to P; from R to X is ½ breast; S to 18 is 1½ inches; shape the back.

## THE SIDEBODY.

From X to Y is ¼ inches; square down from Y; this locates 20; 20 to 17 is ¼ inch more than from S to 18; 1 to 2 is ¾ inch; O to K is ½ breast; point Z is halfway between Y and M; shape the sidebody.

## THE FOREPART.

From M to 4 is ½ waist; square down from 4; this locates 11; from 11 to 12 is ½ inch less than ½ breast; 12 to 28 is the same distance as from D to E; point 5 is halfway between M and 4; point 6 is halfway between L and J; draw a line from 5 through 6 up; A to W and L to 7 is the strap measure plus ¾ inch; draw a line from 7 to P; 7 to 23 is ⅔ inch less than the backshoulder; shape the shoulder and armscye.

Square forwards from 7 by line 5-6; 7 to 9 is ½ breast; draw a rounding line from 9 through 14 to 4; from 9 to 10 is ½ breast; 7 to 8 is ⅛ breast; draw a line from 8 to 10 and shape the gorge; add to the left forepart from 10 to 19, ½ inch; 14 to 22, 4 to 25 and 28 to 30 the same; on the right front add from 19 to 29, 1¼ inches; 22 to 15, 25 to 13 and 30 to 26 is the same.

From 4 back to 27 is 2¼ inches; from Z to Y, X to R and 27 to 21 is the waist measure net; shape the side and bottom of forepart.

The collar is a standing one and is made the same as shown in other diagrams.

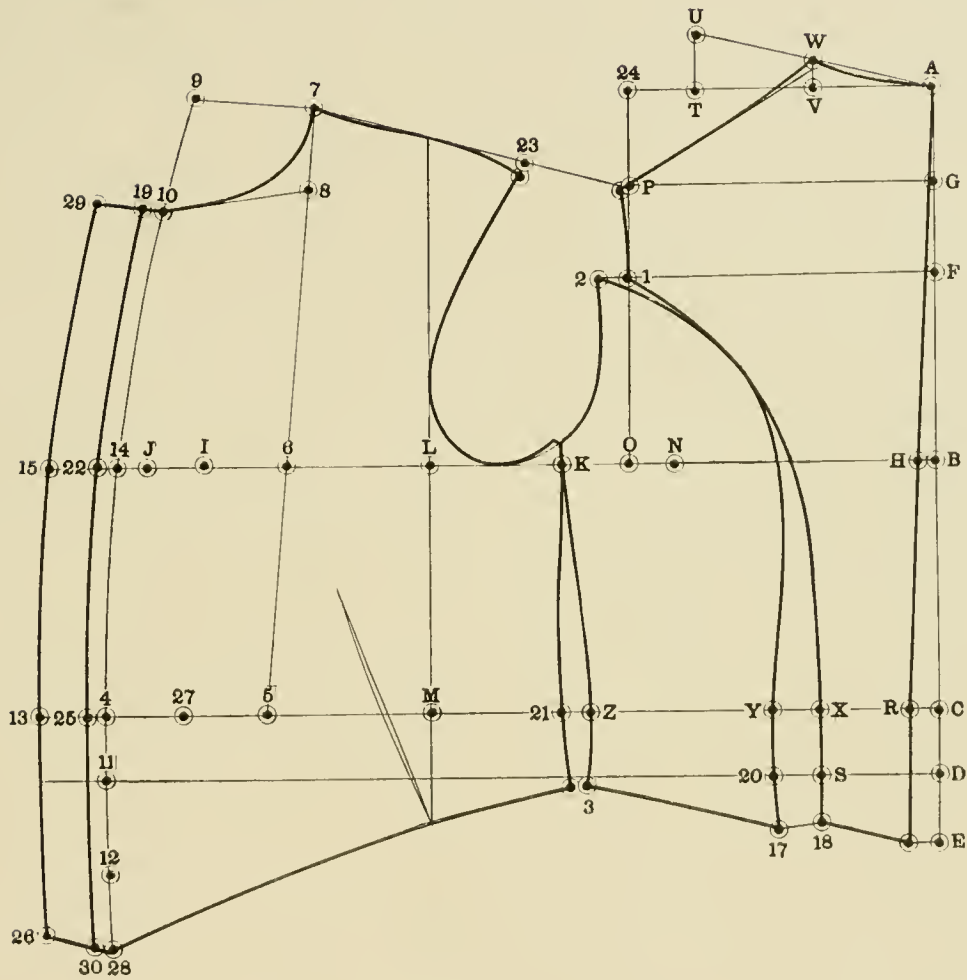

DIAGRAM 115

## DIAGRAM 116

## CHAUFFEUR'S SACK.

The measurements are as follows:

Indentation .....	1½ inches	Overshoulder .....	18 inches
Scye depth .....	9½ inches	Blade .....	13¼ inches
Waist length .....	17 inches	Breast .....	39 inches
Full length .....	32 inches	Waist .....	35½ inches
Strap .....	12¾ inches	Seat .....	41½ inches

Square down and out from A.

From A to B is the scye depth plus ¼ inch; C is waist length; C to D is 6 inches; A to E is full length; F is halfway between A and B; G is halfway between A and F; square out from G, B, C, D and E.

From C to 2 is ¾ inch; draw a line from F to 2 and square down; 1 to H is ½ breast; H to I is 1¾ inches; 1 to J is ¾ inch; K is halfway between 1 and H; K to L is 3½ inches; square down from L to locate Q; apply the blade measure from 1 to L which is 13¼ inches and square up; M is halfway between 1 and L; M to N is 1¼ inches; square up from N; N to P is ½ breast; point 4 is halfway between M and N; 22 to 7 is the same distance as from 1 to 4.

From A to 8 is 6¾ inches; 8 to 9 is 1½ inches; draw a line from A to 9; A to 10 is ½ breast; square up from 10 to locate 11; draw a line from ¼ inch below 11 to O and shape the back; from Q to S is ½ waist; point T is halfway between Q and S; point U is halfway between L and I; draw a line from T through U up.

From A to 11 and L to V is the strap measure plus ¾ inch; draw a line from V to O; V to Z is ¾ inch less than the back shoulder width; shape the shoulder and armseye; square forwards from V by line T-U; V to W is ½ breast plus ½ inch; draw a rounding line from W to J; from W to X is ½ breast; V to Y is ⅛ breast; draw a line from Y to X and shape the gorge; from J to 12 is 3½ inches; S to 13 is the same; from Q to R is ¾ inch; draw a line from R through S to 13 and square down by that line; this locates 16.

From 16 to 17 is ⅛ breast; from 6 back to 15 is the same distance as H to 12; 14 to 3 and 15 to 20 is the seat measure; from 20 back to 19 is 2 inches; square up from 19 to locate 18; draw a line from 18 through 20 down and shape the side of forepart; from 18 to 21 is the same distance as from 5 to 7; shape the bottom of forepart and finish.

## THE COLLAR.

From V to 26 is the same distance as A to 11 on the backpart; from 26 back to 24 is 1 inch; 29 to 30 is ½ inch; shape the collar crease from 24 through V and 30 to X; from 24 to 28 is 1¼ inches; V to 23 is the same; X to 31 is ½ inch; from 24 to 25 is the width of the collar desired; X to 32 is the same; from V to 27 is ¾ inch; place the square to 27-24 and square out to 25; shape the collar as shown by the broken line and finish.

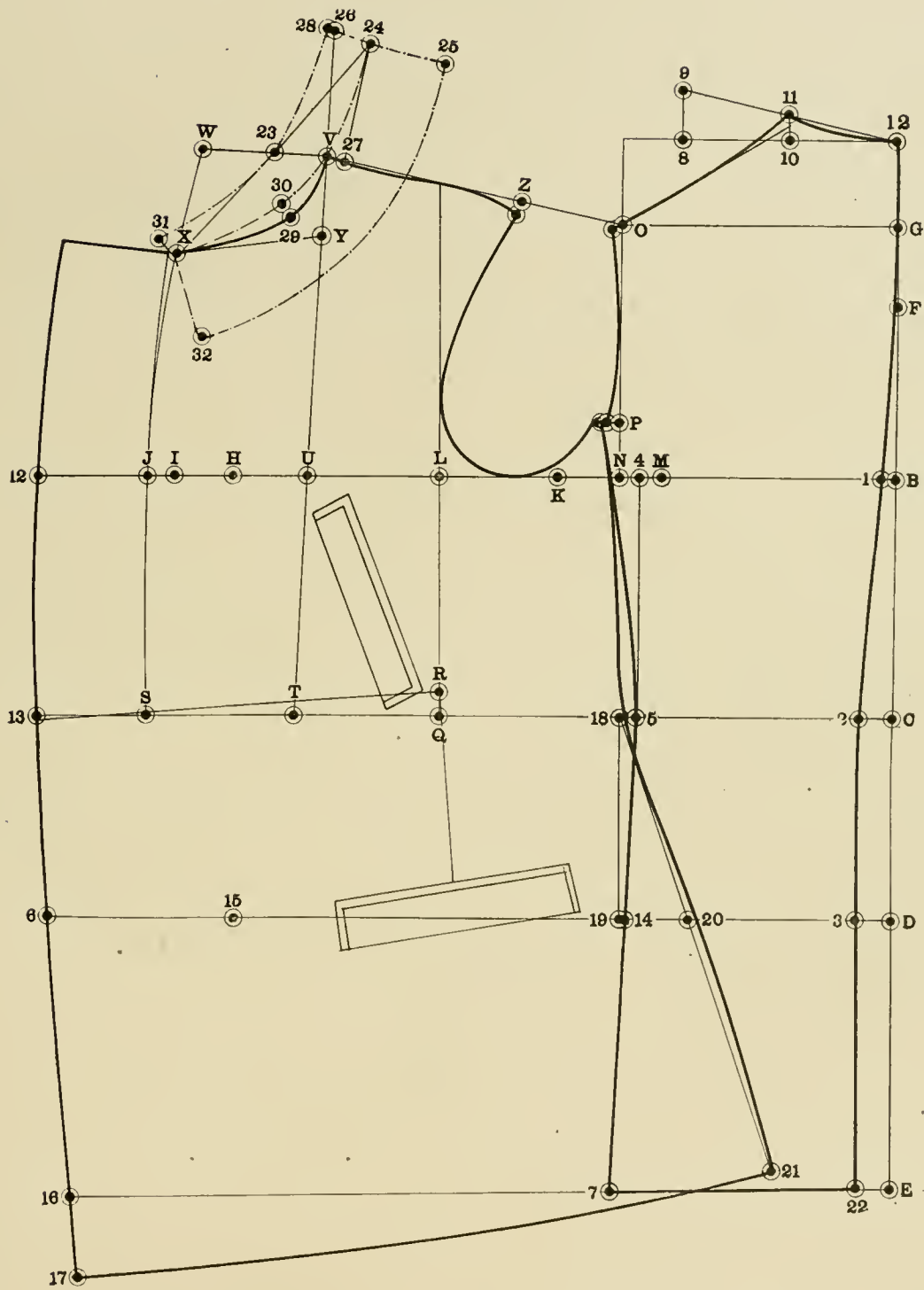

DIAGRAM 116

## DIAGRAM 117

## CHAUFFEUR'S OVERCOAT.

The measurements as taken over the waistcoat are as follows:

Scye depth .....	9 $\frac{3}{8}$ inches	Overshoulder .....	17 $\frac{5}{8}$ inches
Waist length .....	17 inches	Blade .....	13 inches
Full length whatever height requires		Breast .....	38 inches
Strap .....	12 $\frac{1}{2}$ inches	Waist .....	34 inches

Square down and out from A; A to B is the scye depth plus  $\frac{1}{4}$  inch; B to C is  $\frac{3}{4}$  inch; A to D is waist length plus  $\frac{3}{4}$  inch; D to 23 is 6 inches; A to E is full length; F is halfway between A and C; G is halfway between A and F; square out from G, B, C, D, 23 and E.

From D to 2 is  $\frac{3}{4}$  inch; draw a line from F through 2 down; this locates 22; square forwards from 22; from 1 to 21 is 1 $\frac{1}{2}$  inches; if the material is heavy it may be 1 $\frac{3}{4}$  or 2 inches; 21 to H is  $\frac{1}{2}$  breast; H to I is 1 $\frac{3}{4}$  inches; I to J is  $\frac{3}{4}$  inch; K is halfway between 21 and H; K to L is 3 $\frac{1}{2}$  inches; square down from L to locate Q; apply the blade measure from 21 to L which is 13 inches and square up.

From L back to 15 is  $\frac{1}{2}$  inch; M is halfway between 1 and 15; M to N is 1 $\frac{1}{4}$  inches; square up and down from N; from 19 to 6 is 1 $\frac{1}{2}$  inches; 19 to 20 is 3 $\frac{1}{2}$  inches or make the distance from 6 to 20, 5 inches; draw a line from N through 6 down; N to 4 is 1 inch; 4 to 3 is  $\frac{1}{2}$  inch; draw a line from 3 through 20 down; 3 to 18 is the same distance as from 3 to 5.

From A to 8 is 6 $\frac{3}{8}$  inches; 8 to 9 is 1 $\frac{1}{2}$  inches; draw a line from A to 9; A to 10 is  $\frac{1}{2}$  breast; square up from 10 to locate 11; draw a line from 11 to O and shape the back; from Q to S is  $\frac{1}{2}$  waist; point T is halfway between Q and S; point U is halfway between L and I; draw a line from T through U up; A to 11 and L to V is the strap measure plus  $\frac{3}{4}$  inch; draw a line from V to O; from V to Z is  $\frac{3}{8}$  inch less than the back shoulder width; shape the shoulder and armscye.

Square forwards from V by line T-U; V to W is  $\frac{1}{2}$  breast plus  $\frac{1}{2}$  inch; draw a line from W to J; W to X is  $\frac{1}{2}$  breast; V to Y is  $\frac{1}{8}$  breast; draw a line from Y to X and shape the gorge; X to 25 is  $\frac{3}{4}$  inch; cut out a V as between X and 25; J to 12 is 3 $\frac{1}{2}$  inches; S to 13 is the same; Q to R is 1 inch; draw a line from R to 13 and square down by that line; this locates 16; 16 to 17 is  $\frac{1}{8}$  breast; 12 to 24 is 1 $\frac{1}{4}$  inches.

The button stand on this coat will be 8 $\frac{1}{2}$  inches at the breast and 7 $\frac{1}{2}$  inches from the waist down; add from 3 to 7, 1 $\frac{1}{4}$  inches; from 5 to 11 is the same and reshape the back as shown by the broken line. If a center plait is desired, add from G to 26, 2 $\frac{1}{2}$  to 3 inches and from 22 to 27 the same.

## THE COLLAR.

Draw a straight line from X through V; from X to 28 is the same as the size of the shirt collar, in this case 7 $\frac{1}{2}$  inches; point 29 is halfway between X and 28; square up from 29; from 29 to 30 is 1 $\frac{1}{4}$  inches; shape the collar stand from 28 through 30 to X; from 28 to 31 is 1 $\frac{1}{4}$  inches; from X to 32 is  $\frac{1}{2}$  inch; shape the collar crease from 31 through 33 to 32; from 31 to 33 is the same distance as the top width of the back; place the square to points 31-33 and square up to 34; from 33 to 34 is  $\frac{3}{4}$  inch; now place the square to points 31-34 and square up to 35; 31 to 35 is the width of the collar desired; 32 to 36 is the same; shape the collar and finish as shown.

The crease line of this collar after being cut out will be found to be 2 inches more than the size of the shirt collar, in this case it is to be 8 $\frac{1}{2}$  inches plus 2 seams or 17 inches finished.

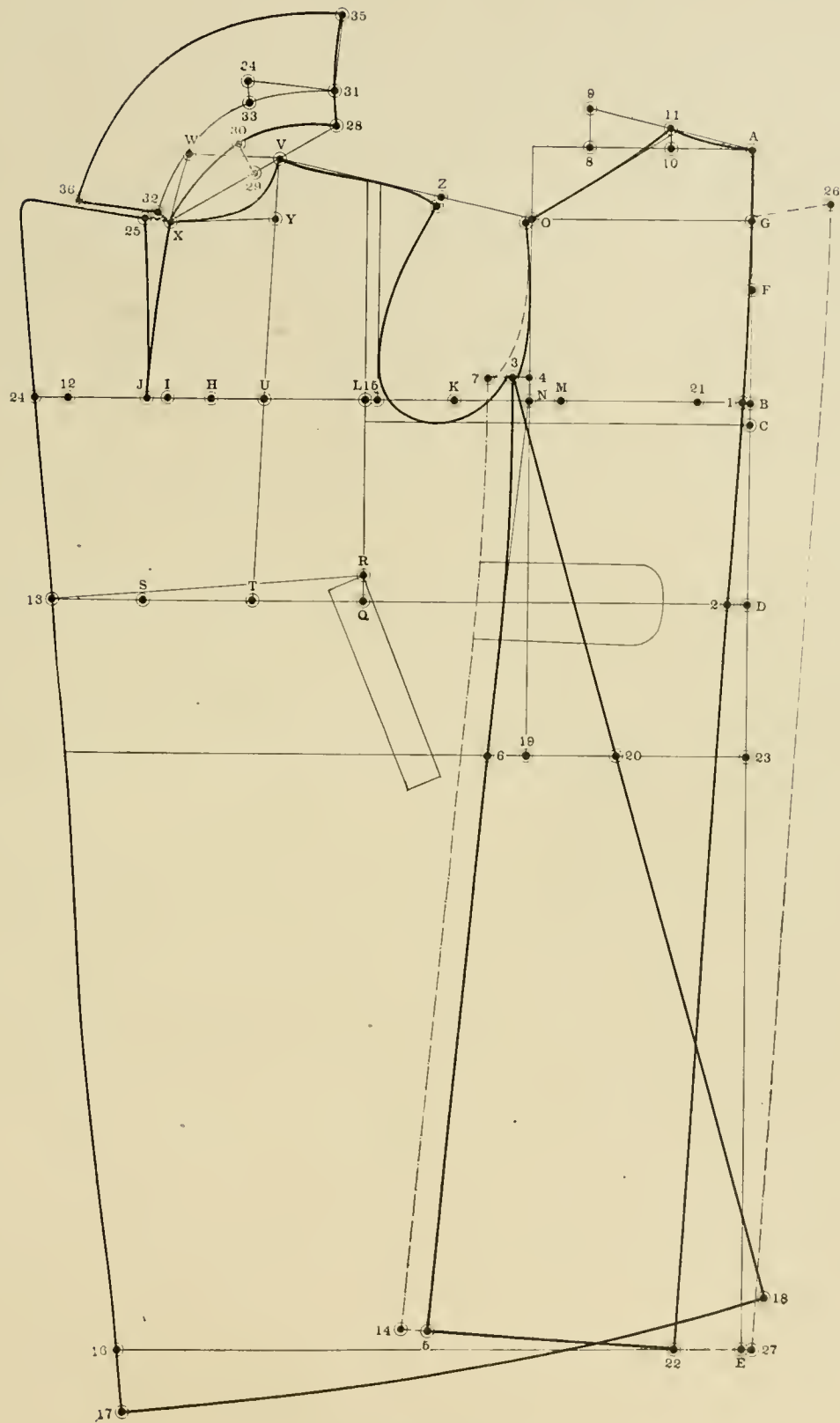

DIAGRAM 117

## DIAGRAM 118

## RIDING SACK.

The measurements are as follows:

Scye depth .....	9 inches	Blade .....	12½ inches
Waist length .....	16½ inches	Breast .....	36 inches
Full length .....	34 inches	Waist .....	32 inches
Strap .....	12 inches	Seat .....	38 inches
Overshoulder .....	17 inches		

Square down and out from A.

From A to B is the scye depth net; C is waist length; C to D is 6 inches; A to E is full length; F is halfway between A and B; G is halfway between A and F; square out from G, B, C, D and E.

From C to 23 is ½ indentation in this case ¾ inch; draw a line from A to 23; 23 to 2 is the same as C to 23; square down from 2; this locates 22; now shape the backpart from F to 2 and down; from 1 to H is ½ breast; H to I is 1¾ inches; I to J is ¾ inch; K is halfway between 1 and H; K to L is 3½ inches; square down from L to locate Q; apply the blade measure from 1 to L which is 12½ inches and square up.

Point M is halfway between 1 and L; M to N is ¼ inches; square up from N; N to P is ½ breast; N to 1 is ¾ inch; square down from 1 to 5; 22 to 7 is the same distance as 1 to 4; draw a line from 5 to 7; add from 7 to 24, 1¼ inches.

From A to 8 is 6⅜ inches; 8 to 9 is 1½ inches; draw a line from A to 9; from A to 10 is ⅓ breast; square up from 10 to locate 11; draw a line from ¼ inch below 11 to O and shape the back; from Q to S is ½ waist; point T is halfway between Q and S; point U is halfway between L and I; draw a line from T through U up; A to 11 and L to V is the strap measure plus ¾ inch; draw a line from V to O.

For a riding sack it is desirable to have the shoulder quite easy, therefore shape the shoulder above point Z; V to Z is ⅜ inch less than the back shoulder width; shape the shoulder and armseye; square forwards from V by line T-U; V to W is ⅓ breast; W to 25 is 1 inch; draw a line from 25 to J; V to Y is ⅝ breast; square forwards from Y and shape the gorge; J to 12 is 1 inch; S to 13 is the same; from Q to R is ½ indentation; draw a line from R through S; square down from 13 by line R-S; this locates 16; 16 to 17 is ⅝ breast.

From 6 back to 15 is 3 inches; S to 14 is 2½ inches; 19 to 3 and 15 to 20 is the seat measure; 5 to 2 and 14 to 18 is the waist measure plus ¾ inch; draw a line from 18 through 20 down; 18 to 21 is the same distance as from 5 to 24; shape the bottom of forepart and finish.



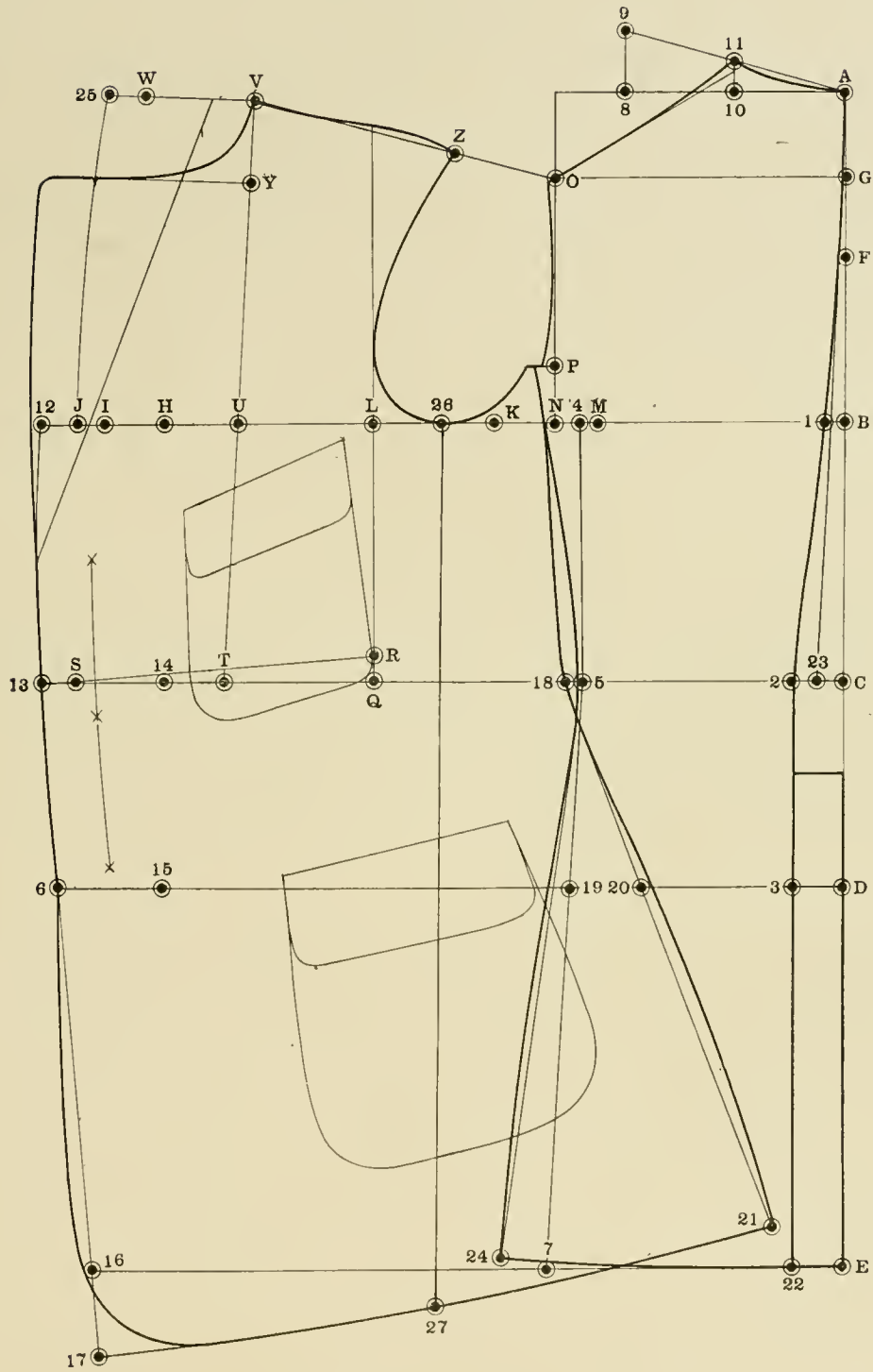

DIAGRAM 118

## DIAGRAM 119

## RIDING SACK, (Continued).

After the backpart and forepart have been cut out, split the front as from 26 down to 27 and proceed as in this diagram: keep the pattern close at 26 and open it between 27 and 28 about  $1\frac{1}{2}$  inches; reshape the underarm fish as shown down to 18 and finish.

This will give the coat the proper amount of drapery.

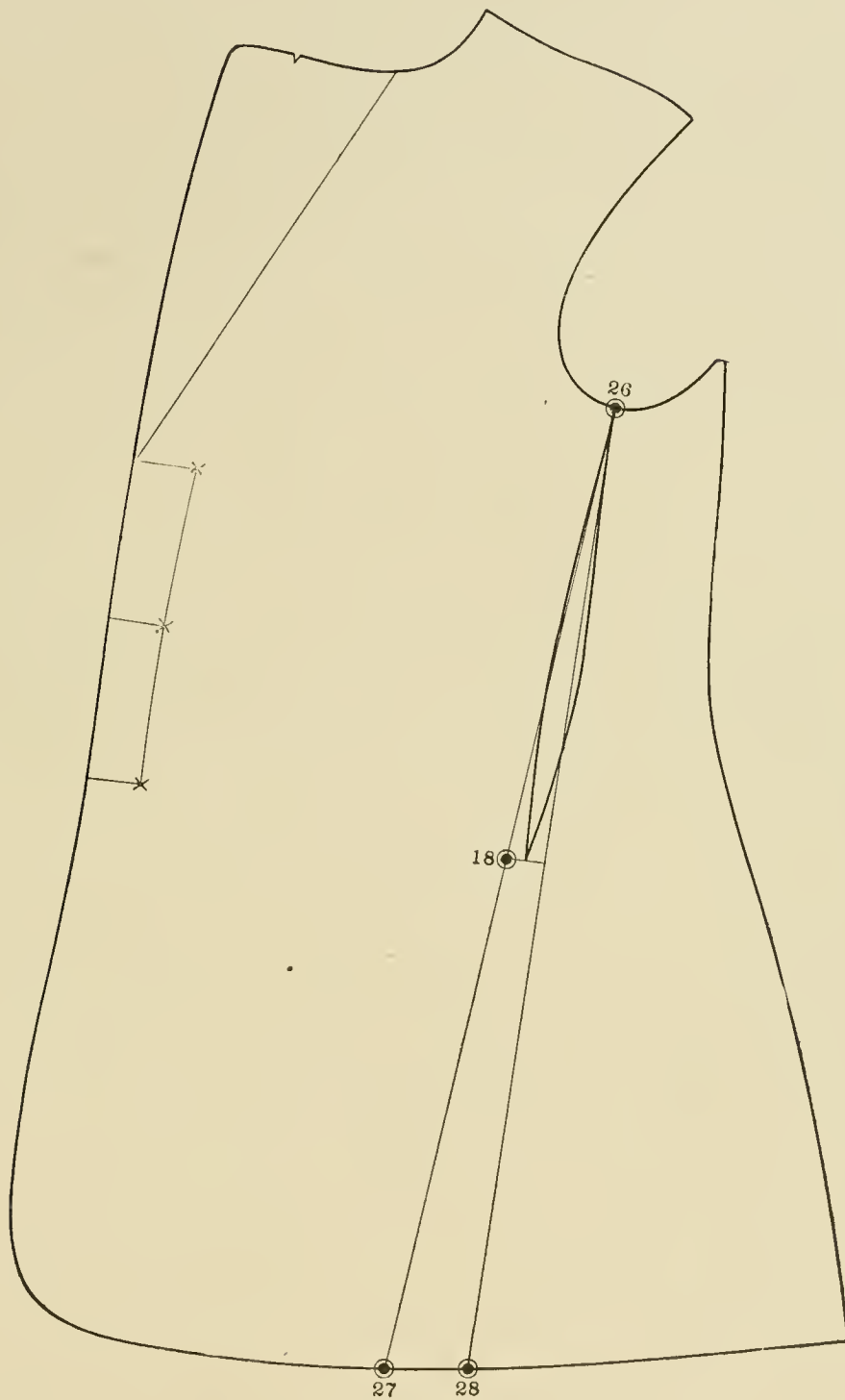

DIAGRAM 119

## DIAGRAM 120

## RIDING FROCK.

The measurements are as follows:

Scye depth .....	$9\frac{3}{8}$ inches	Overshoulder .....	$17\frac{5}{8}$ inches
Natural waist length .....	$16\frac{1}{2}$ inches	Blade .....	13 inches
Fashionable waist length .....	$18\frac{1}{4}$ inches	Breast .....	38 inches
Full length whatever style calls for.		Waist .....	34 inches
Strap .....	$12\frac{1}{2}$ inches		

Square down and out from A.

From A to B is the scye depth plus  $\frac{1}{4}$  inch; C is natural waist length; D is fashionable waist length; E is full length; F is halfway between A and B; G is halfway between A and F; square out from G, F, B, C, D and E.

From C to R is  $\frac{1}{2}$  indentation; draw a straight line from A through R to Q and square down; H to I is  $\frac{1}{2}$  breast; I to J is  $1\frac{1}{2}$  inches; J to 14 is  $\frac{3}{4}$  inch; K is halfway between H and I; K to L is  $3\frac{1}{2}$  inches; square down from L to locate M; apply the blade measure from H to L which is 13 inches and square up; N is halfway between H and L; N to O is  $1\frac{1}{4}$  inches; from A to 24 is the same distance as H to O; draw a line from O to 24.

From A to T is  $6\frac{3}{8}$  inches; T to U is  $1\frac{1}{2}$  inches; draw a line from A to U; A to V is  $\frac{1}{8}$  breast; square up from V to locate W; draw a line from  $\frac{1}{4}$  inch below W to P; from Q to S is  $\frac{1}{8}$  breast; square down from S and shape the back; X to Y is  $1\frac{1}{4}$  inches; 1 to 2 is  $\frac{3}{4}$  inch; point Z is halfway between Y and M; point 3 is  $\frac{1}{2}$  inch above the waistline; shape the sidebody as shown.

From M to 4 is  $\frac{1}{2}$  waist; square down from 4; this locates 11; 11 to 12 is  $\frac{1}{8}$  breast less 1 inch. In a riding frock it is necessary to have the front waist short so that when sitting on a horse the coat should not break above the waist seam.

Point 5 is halfway between M and 4; point 6 is halfway between L and J; draw a line from 5 through 6 up; A to W and L to 7 is the strap measure plus  $\frac{3}{4}$  inch; draw a line from 7 to P; 7 to 23 is  $\frac{3}{8}$  inch less than W to P; shape the shoulder and armscye; square forwards from 7 by line 5-6; 7 to 9 is  $\frac{1}{8}$  breast plus  $\frac{1}{4}$  inch; draw a rounding line from 9 to 14; 7 to 8 is  $\frac{1}{8}$  breast; square forwards from 8 and shape the gorge; from 4 back to 27 is  $2\frac{1}{4}$  inches; Z to Y, X to R and 27 to 21 is the waist measure net; shape the side and bottom of forepart. From 14 to 15 is  $1\frac{1}{4}$  inches; 4 to 13 is the same.

## THE SKIRT.

Draw a straight line from 12 to 22; this locates point 16; 22 to 20 is 1 inch; draw a line from 16 to 20 and square down; from 20 to 25 is 9 inches; 25 to 26 is  $1\frac{1}{2}$  inches; draw a line from 20 through 26 down; 20 to 19 is  $\frac{1}{4}$  inch more than from S to 17; 12 to 18 is the same distance as 20 to 19; draw a line from 19 to 18; round the skirt  $\frac{5}{8}$  inch at 26; shape the front edge and finish.

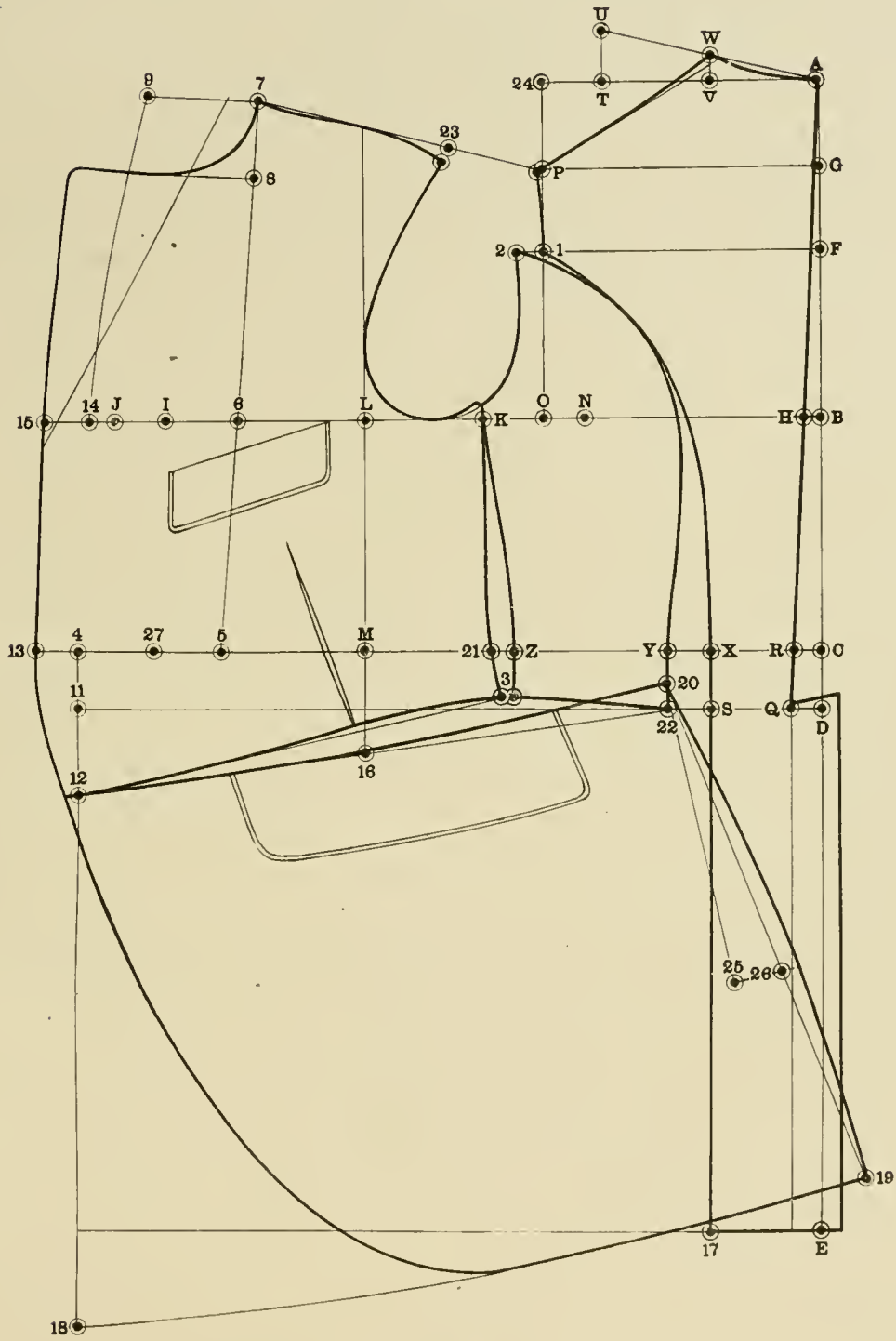

DIAGRAM 120

## DIAGRAM 121

## COLLARS.

Figure 1 shows a collar made up with a straight crease; after deciding upon the length of the lapel, go out from A to B,  $1\frac{1}{4}$  inches; this represents the collar stand; draw a line from the lapel crease through B; from E to D is  $1\frac{1}{4}$  inches; from C to D is  $\frac{1}{4}$  inch more than the top width of the back; square down from E to D by line B-E; swing out the collar about  $\frac{1}{8}$  inch at F and make the distance from E to F according to the style of collar desired and shape.

For a long roll the collar is made as shown on figure 2. As the crease is to be straight, this collar is made up in the same manner as described for figure 1. From A to B is  $1\frac{1}{4}$  inches; draw a line for the crease through B; C to D is  $\frac{1}{4}$  inch more than the top width of the back; shape the collar the same as in figure 1.

Figure 3 shows a collar made up slightly horse-shoe, or a rounded collar slightly hollowed at the crease line. It is made as follows: A to B is 1 inch; draw a line through B; this locates E; from E to G is  $\frac{5}{8}$  inch; G to H is  $1\frac{1}{4}$  inches; draw a line from H to A; from C to H is the same as the top width of the back, plus  $\frac{1}{4}$  inch; square up from H to G by line A-H swing out the collar about  $\frac{1}{4}$  inch at F; G to F is the width of collar desired; shape the collar. This collar must be slightly shrunk on the crease.

For a man with a short neck or for a fat man's coat, the collar should be made as shown on figure 4. From A to B is  $\frac{3}{4}$  inch; draw a line from the lapel crease through B; this locates E; from E to G is 1 inch; G to H is the same; draw a line as from H through C to A; from C to H is  $\frac{1}{4}$  inch more than the top width of back; square up from H to G by line H-C and finish the collar.

Figure 5 shows how to make an ulster collar to either roll or button; this collar is made as follows: from A to B is  $1\frac{1}{4}$  inches; draw a line through B; C to D is  $1\frac{1}{4}$  inches; D to E is the same; draw a line from E through F to A; from F to E is the same as the top width of back plus  $\frac{1}{4}$  inch; from F to G is  $1\frac{1}{4}$  inches; shape the collar crease from D through G into the crease line; square up from G.

From G to H is  $\frac{3}{4}$  inch; place the square to point D-H and square up; make the outer leaf of collar according to style desired and finish.

To have this collar button up to the neck proceed as follows: go up from D to I,  $\frac{3}{8}$  inch and make another collar stand as from I to J. In the making up of this collar the canvas should be cut on the bias and then bent in at line I-B-J. Both the stand and leaf should be treated in this manner so that when rolled up, the collar will break on that line.

Figure 6 shows how to make a standing collar, also a standing rolling collar. This collar is made as follows: draw a line from A through C; from A to B is 1 inch more than  $\frac{1}{2}$  of the shirt collar size. This collar when finished must measure 2 inches more than the shirt collar; draw a line from B through D into the gorge; square up from B by line B-D; from B to E is the width of the collar desired plus a seam; A to F is the same, shape the collar as shown by the solid line.

For a standing rolling collar proceed as follows: hollow the outer leaf at G about  $\frac{1}{2}$  inch; place the standing collar so as line E-G will touch on the broken line corresponding at those points; shape out as from E to H and from F to I; now cut out the outer leaf the same as shown by the broken line; those two parts of the collar are to be sewn together at line E-G-F.

All the other style collars are shown and described in conjunction with the various coat diagrams.

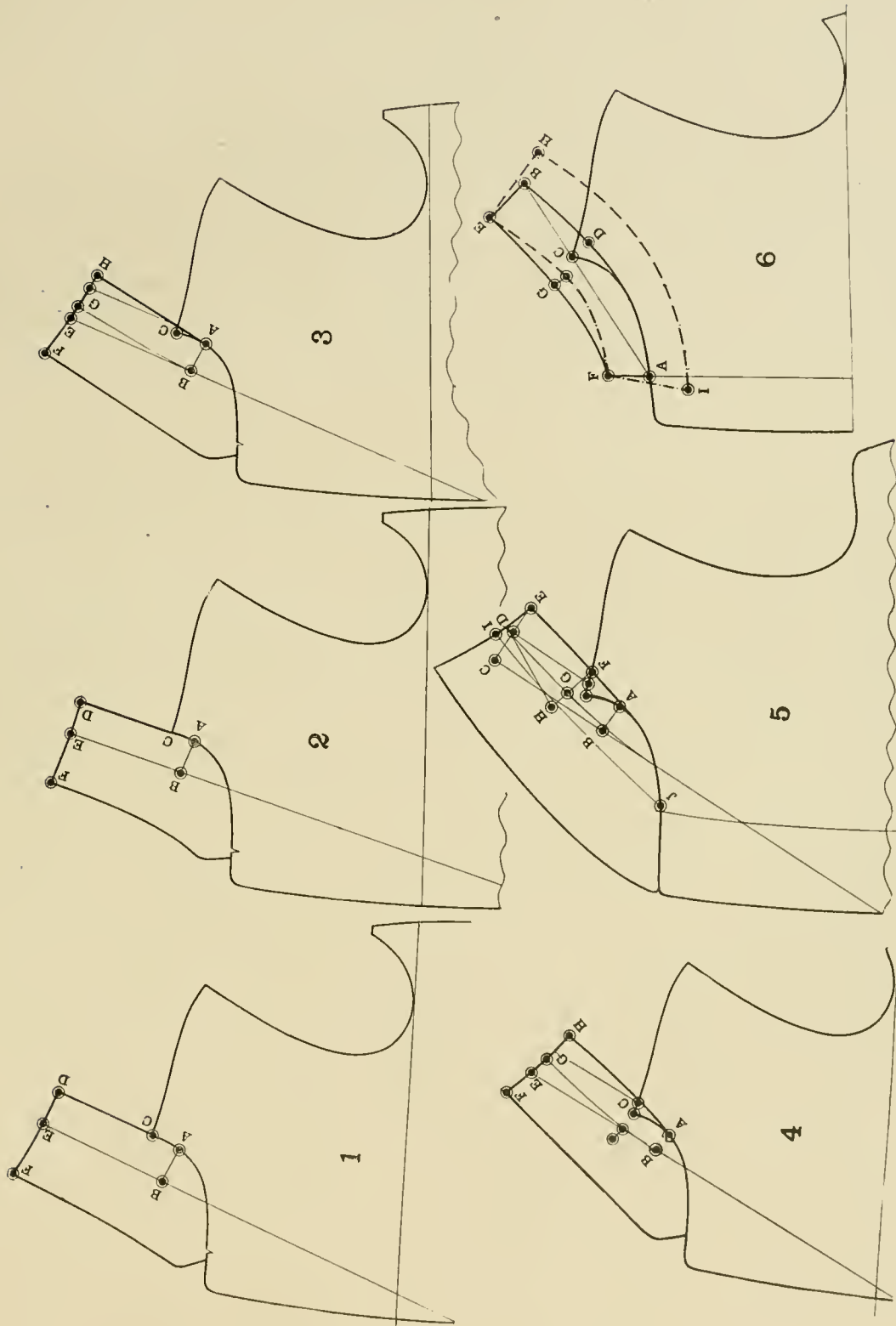

DIAGRAM 121

## DIAGRAM 122

## SINGLE-BREADED NO-COLLAR WAISTCOAT.

In measuring for a waistcoat, all that is needed is the opening and full length measurements, otherwise the same measurements are used as for a coat.

The measurements for this waistcoat are as follows:

Scye depth .....	9 inches	Breast .....	36 inches
Waist length .....	16½ inches	Waist .....	32 inches
Strap .....	12 inches	Opening .....	11½ inches
Overshoulder .....	17 inches	Full length .....	25½ inches
Blade .....	12½ inches		

Square down and out from A.

From A to B is the scye depth plus ¼ inch; C is waist length; C to D is 2¾ inches; this distance may be increased or decreased according to your own individual ideas; E is halfway between A and B; F is halfway between A and E; square out from F, B, C, and D.

From C to 2 is ¾ inch; draw a line from E to 2; this locates 1; from 1 to G is ½ breast; G to H is 1¼ inches; H to I is ¾ inch; J is halfway between 1 and G; J to K is 3 inches; this makes the waistcoat one size smaller than the coat; square down from K to locate L; apply the blade measure minus ½ inch from 1 to K, which in this case is 12 inches and square up; X is halfway between 1 and K; from X to 3 is ½ inch; square up from 3; this locates 20; from 20 to W is 1 inch.

From A to S is 6¾ inches; S to T is 1½ inches; draw a line from A to T; from A to U is ½ breast; square up from U to locate V; draw a line from V to W; now add ¼ inch to the shoulder height as at 5-4, also add a seam on top of line A-V.

From L to M is ½ waist; N is halfway between L and M; O is halfway between K and H; draw a line from N through O up; A to 5 and K to P is the strap measure plus ¾ inch; draw a line from P to W; from P to R is ¾ inch less than 5 to 4; go forwards from K about ¾ inch and shape the shoulder and armseye; square forwards from P by line N-O; P to Y is ½ breast plus ½ inch; shape the front edge from Y through I and M down.

From P to Q is 1 inch; from P to 11 is ¼ inch less than from A to 5 on the backpart; draw a line from 11 to Q; make the depth of the neckpiece as from Q back 1¼ inches; apply the opening measure as from 11 to wherever it comes, adding in this case only ¼ inch and the full length down to Z plus ¾ inch.

From L to 6 is 1 inch; J to 12 is 1¼ inches; draw a line from 12 to 6 and shape the side and bottom of forepart; 7 is halfway between 2 and 6; from 7 to 8 is ¼ waist; 7 to 9 is ¼ waist plus ¾ inch; shape the center of back through 9 and the side from 12 through 8 to 10; lengthen the back at 10, ⅜ inch and finish.

If the overshoulder is to be used, apply it in the same way as shown on sack coat, adding 1 inch to it.



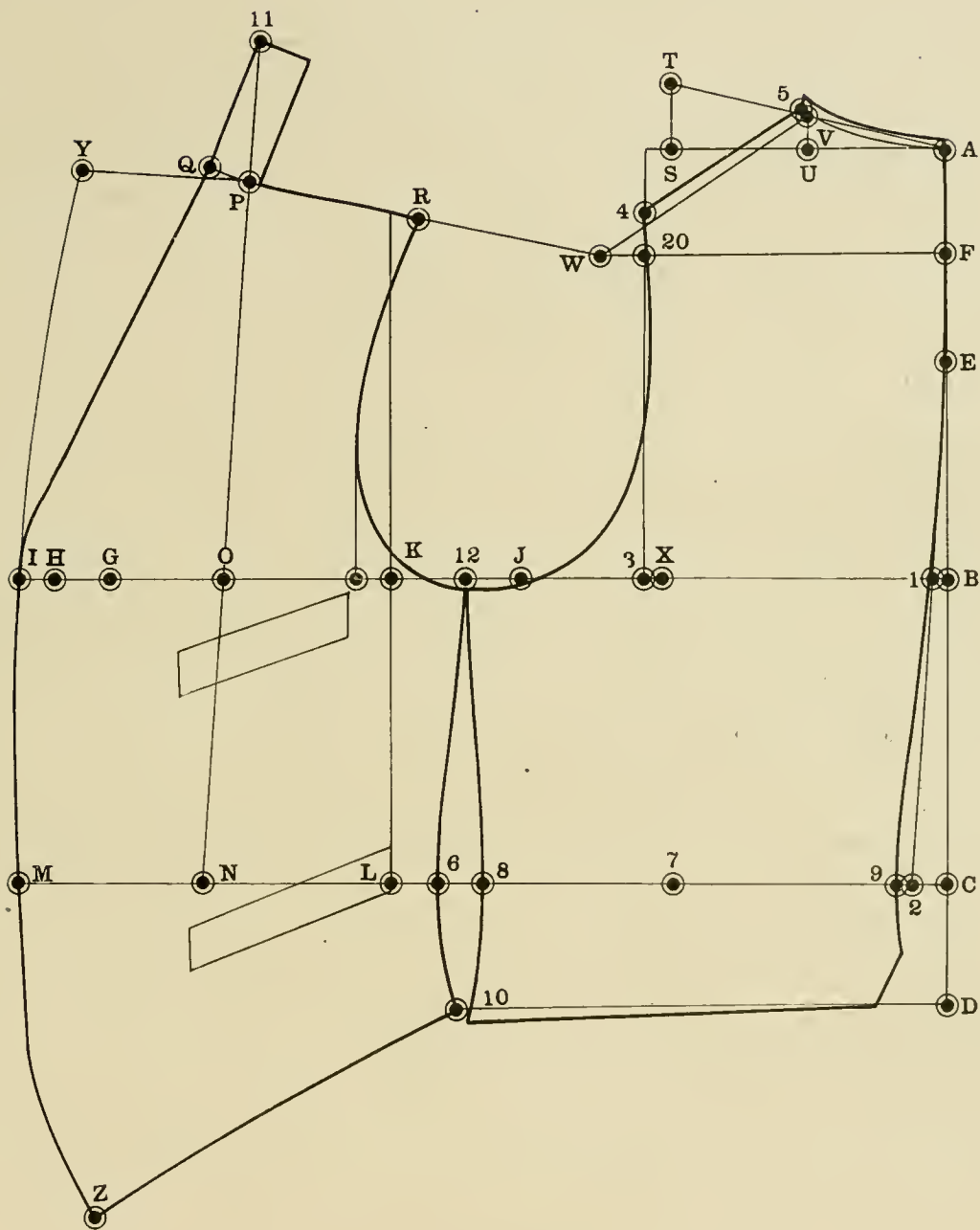

DIAGRAM 122

## DIAGRAM 123

## SINGLE-BREASTED WAISTCOAT WITH NOTCH COLLAR

The measurements are as follows:

Scye depth .....	$9\frac{3}{8}$ inches	Breast .....	38 inches
Waist length .....	17 inches	Waist .....	$34\frac{1}{2}$ inches
Strap .....	$12\frac{1}{2}$ inches	Opening .....	13 inches
Overshoulder .....	$17\frac{5}{8}$ inches	Full length .....	$26\frac{1}{2}$ inches
Blade .....	13 inches		

Square down and out from A.

From A to B is scye depth plus  $\frac{1}{4}$  inch; C is waist length; C to D is  $2\frac{3}{4}$  inches; E is halfway between A and B; F is halfway between A and E; square out from F, B, C and D.

From C to 2 is  $\frac{3}{4}$  inch; draw a line from E to 2; this locates 1; 1 to G is  $\frac{1}{2}$  breast; G to H is  $1\frac{1}{4}$  inches; H to I is  $\frac{3}{4}$  inch; J is halfway between 1 and G; J to K is 3 inches; square down from K to locate L; apply the blade measure minus  $\frac{1}{2}$  inch from 1 to K, in this case it is  $12\frac{1}{2}$  inches; square up.

X is halfway between 1 and K; X to 3 is  $\frac{1}{2}$  inch; square up from 3; this locates 20; 20 to W is 1 inch; A to S is  $6\frac{3}{8}$  inches; S to T is  $1\frac{1}{2}$  inches; draw a line from A to T; A to U is  $\frac{1}{2}$  breast; square up from U to locate V; draw a line from V to W; add on  $\frac{1}{4}$  inch to the shoulder as at line 5-4; also add  $\frac{1}{4}$  inch on top of back as at A-V.

From L to M is  $\frac{1}{2}$  waist; point N is halfway between L and M; O is halfway between K and H; draw a line from N through O up; A to 5 and K to P is the strap measure plus  $\frac{3}{4}$  inch; draw a line from P to W; from P to R is  $\frac{3}{8}$  inch less than 5 to 4; go forwards from K  $\frac{3}{4}$  inch and shape the shoulder and armseye as shown; square forwards from P by line N-O; from P to Q in this case is  $\frac{3}{4}$  inch. This vest being cut with a collar it does not lose a seam at Q as the collar is sewed on flat.

From P to Y is  $\frac{1}{2}$  breast plus  $\frac{1}{2}$  inch; shape the front edge from Y through 1 and M down; apply the opening measure plus  $\frac{3}{4}$  inch in this case from A to 5 and P to I, also the full length plus 1 inch from A to 5 and P to Z; from L to 6 is 1 inch; from J to 12 is  $1\frac{1}{4}$  inches; draw a line from 12 to 6 and shape the side of forepart and finish.

Point 7 is halfway between 2 and 6; from 7 to 8 is  $\frac{1}{4}$  waist; 7 to 9 is  $\frac{1}{4}$  waist plus  $\frac{3}{4}$  inch; draw a line from 12 to 8 and shape the side of backpart, also the center seam; finish the vest as usual, adding  $\frac{3}{8}$  inch to the backpart as 10.

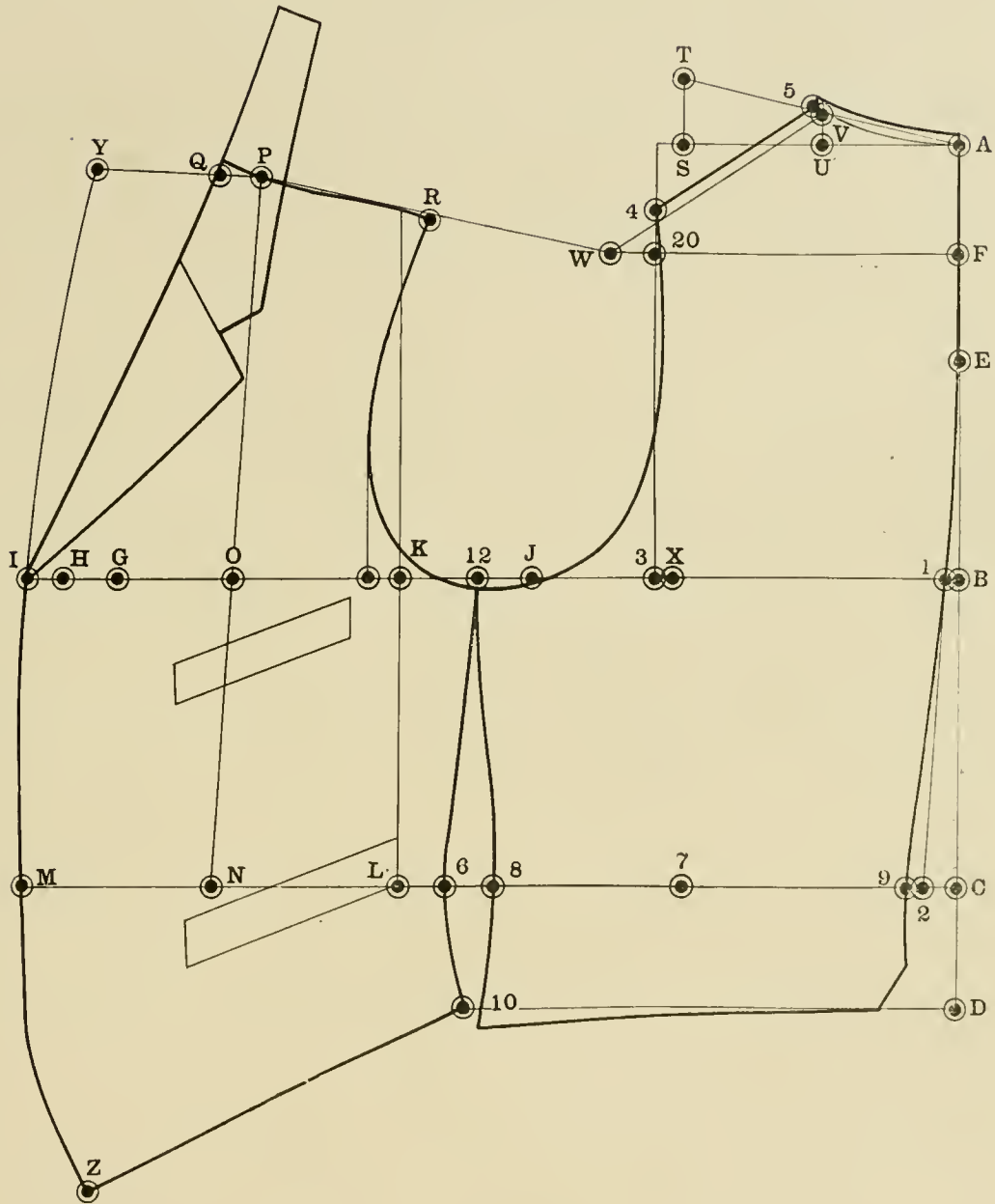

DIAGRAM 123

## DIAGRAM 124

This diagram shows a waistcoat for a figure with a large blade. The measurements are the same as in the previous diagram except that the blade measure is  $13\frac{1}{2}$  inches.

Square down and out from A.

From A to B is the scye depth plus  $\frac{1}{4}$  inch; C is waist length; C to D is  $2\frac{3}{4}$  inches; E is halfway between A and B; F is halfway between A and E; square out from F, B, C and D.

From C to 2 is  $\frac{3}{4}$  inch; draw a line from E to 2; 1 to G is  $\frac{1}{2}$  breast; G to H is  $1\frac{1}{4}$  inches; H to I is  $\frac{3}{4}$  inch; J is halfway between 1 and G; from J to K is 3 inches; square down from K to locate L; apply the blade measure minus  $\frac{1}{2}$  inch from 1 to Z, in this case it is 13 inches; square up and down from Z; X is halfway between 1 and Z; X to 3 is  $\frac{1}{2}$  inch; square up from 3.

From 20 to W is 1 inch; A to 12 is  $\frac{1}{2}$  of the distance between K and Z, in this case  $\frac{1}{4}$  inch; draw a line from 12 to E and shape the center seam as shown by the broken line; from 12 to S is  $6\frac{3}{8}$  inches; S to T is  $1\frac{1}{2}$  inches; draw a line from A to T; 12 to U is  $\frac{1}{2}$  breast; square up from U to locate V; draw a line from V to W; from L to M is  $\frac{1}{2}$  waist; point N is halfway between 6 and M; point O is halfway between Z and H; draw a line from N through O up. Otherwise finish the vest the same as shown in diagrams 122 and 123.

---

 DIAGRAM 125

This diagram shows how to make a waistcoat for a figure with a flat back and full chest. The measurements are the same as described in the previous diagrams with the exception that the blade is  $12\frac{1}{2}$  inches instead of 13 inches.

Square down and out from A.

From A to B is scye depth plus  $\frac{1}{4}$  inch; C is waist length; E is halfway between A and B; F is halfway between A and E; square out from F, B and C.

From C to 2 is  $\frac{3}{4}$  inch; draw a line from E to 2; from 1 to G is  $\frac{1}{2}$  breast; G to H is  $1\frac{1}{4}$  inches; H to I is  $\frac{3}{4}$  inch; J is halfway between 1 and G; from J to K is 3 inches; square down from K to locate L; apply the blade measure minus  $\frac{1}{2}$  inch from 1 to Z, in this case it is 12 inches; square up and down from Z; X is halfway between 1 and Z; X to 3 is  $\frac{1}{2}$  inch; square up from 3.

From A back to 12 is  $\frac{1}{2}$  of the distance of from K to Z, in this case  $\frac{1}{4}$  inch; draw a line from 12 to E; 12 to S is  $6\frac{3}{8}$  inches; S to T is  $1\frac{1}{2}$  inches; draw a line from A to T; from 12 to U is  $\frac{1}{2}$  breast; square up from U to locate V; draw a line from V to W; from L to M is  $\frac{1}{2}$  waist; point N is halfway between 6 and M; point O is halfway between Z and H; draw a line from N through O up.

From 12 to 5 and Z to P is the strap measure plus  $\frac{3}{4}$  inch; shape the back from 12 to E as per broken line. Otherwise finish the waistcoat the same as shown on the other diagrams.

DIAGRAM 124

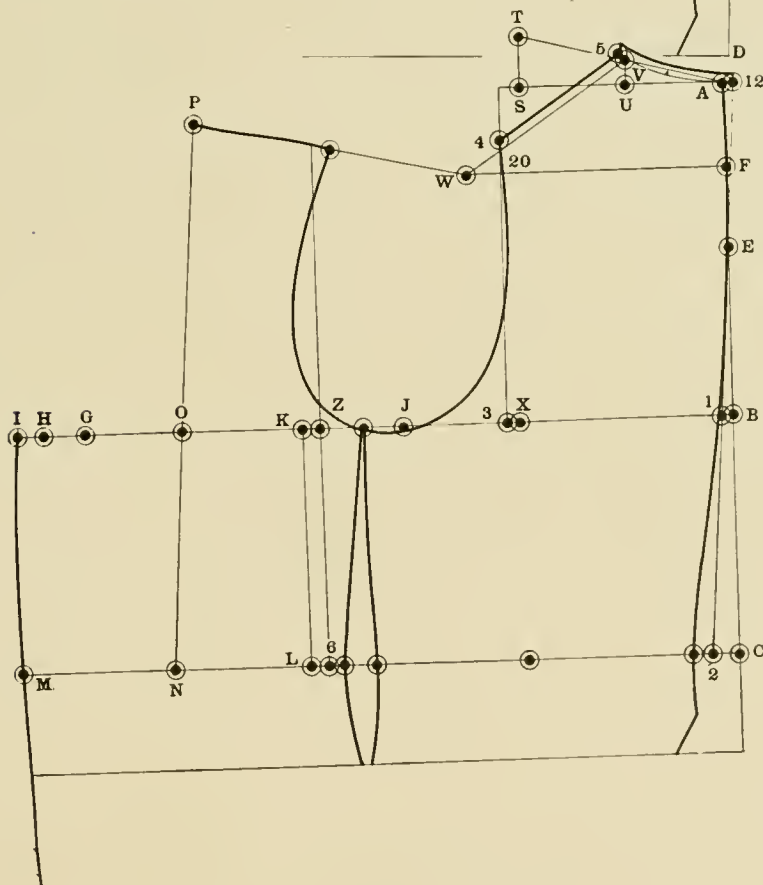
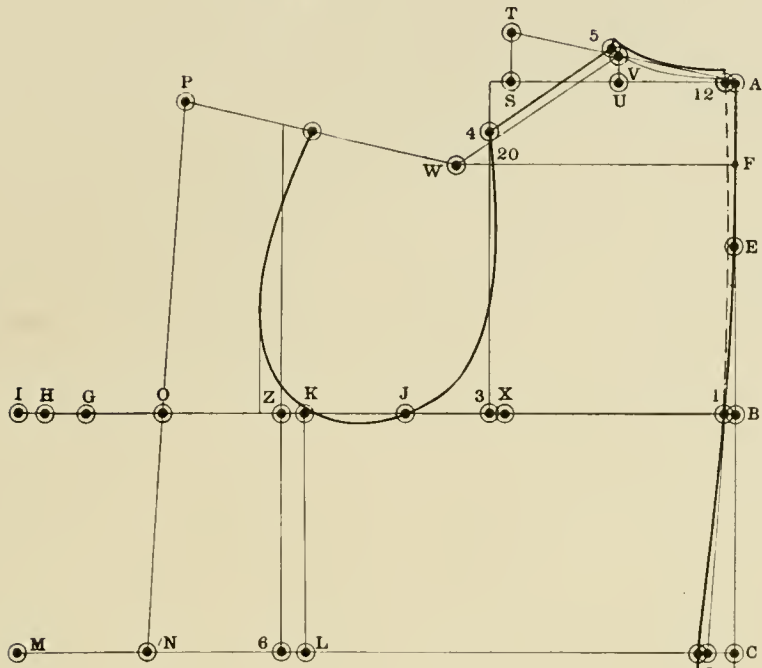

DIAGRAM 125

## DIAGRAM 126

## DOUBLE-BREADED WAISTCOAT.

The measurements are as follows:

Scye depth .....	9½ inches	Blade .....	13¼ inches
Waist length .....	17 inches	Breast .....	39 inches
Strap .....	12¾ inches	Waist .....	35½ inches
Overshoulder .....	18 inches		

Square down and out from A.

From A to B is scye depth plus ¼ inch; C is waist length; C to D is 2¾ inches; E is halfway between A and B; F is halfway between A and E; square out from F, B, C and D.

From C to 2 is ¾ inch; draw a line from E to 2; from 1 to G is ½ breast; G to H is 1¼ inches; H to I is ¼ inch; J is halfway between 1 and G; from J to K is 3 inches; square down from K to locate L; apply the blade measure minus ½ inch from 1 to K, in this case 12¾ inches and square up; X is halfway between 1 and K; from X to 3 is ½ inch; square up from 3 to locate 20; 20 to W is 1 inch; A to S is 6⅜ inches; S to T is 1½ inches; draw a line from A to T.

From A to U is ⅓ breast; square up from U to locate V; draw a line from V to W; add on ¼ inch as at 5-4, also ¼ inch on top of back; from L to M is ½ waist; point N is halfway between L and M; point O is halfway between K and H; draw a line from N through O up; from A to 5 and K to P is the strap measure plus ¾ inch; draw a line from P to W; P to R is ⅜ inch less than 5 to 4; go forwards ¾ inch from K and square up; shape the shoulder and armscye.

From M back to 13 is ½ inch; draw a line from 13 through I up and down; from P to 11 is ¼ inch less than A to 5 on the backpart; from P to Q is 1 inch; draw a line from 11 to Q and finish the top neckpiece.

Apply the opening measure plus ¼ inch from 11 to 17, and the full length plus ¾ inch from 11 to Z; draw a line from Q through 17 down; make the button stand from 15 to 16 according to style; from Z to 14 is 1¼ inches; draw a line from 14 to 16; add on ⅝ inch in front of 16-14 which is for the make-up of edge and the button-hole; from L to 6 is 1 inch; J to 12 is 1¼ inches; draw a line from 12 through 6 and shape the side of forepart.

7 is halfway between 2 and 6; 7 to 8 is ¼ waist; 7 to 9 is ¼ waist plus ¾ inch; shape the center and side of backpart and finish, adding to the backpart ⅜ inch at 10.

Where a double-breasted waistcoat is cut without a separate rever, it is well to cut a fish through the pocket as shown on this diagram.

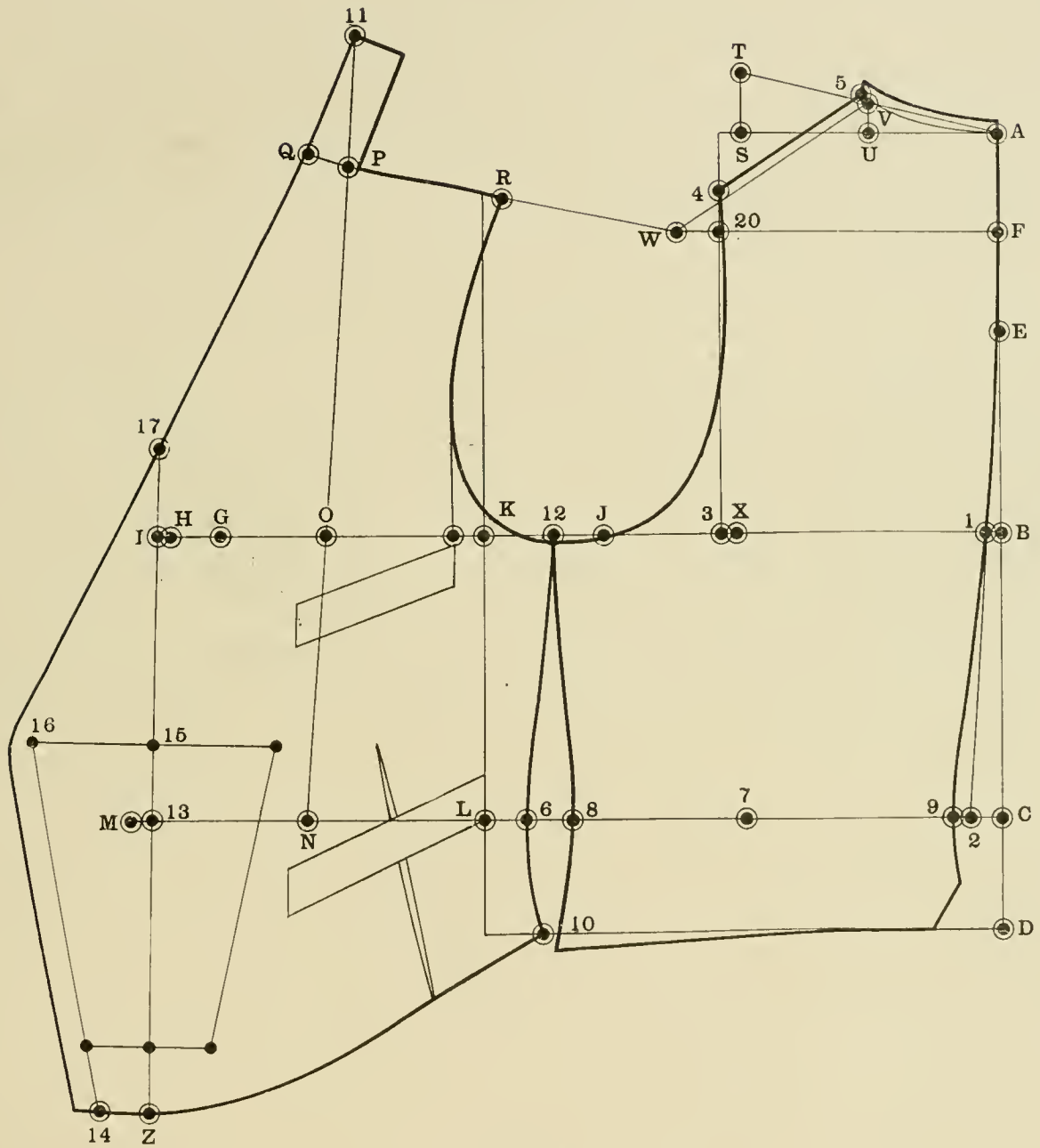

DIAGRAM 126

### DIAGRAM 127

After the forepart is cut out, crease it over as at line 17-Z; shape off the bottom; mark the buttons and buttonholes as shown and finish.

---

### DIAGRAM 128

If a waistcoat is cut with a separate rever proceed as on Diagrams 128 and 129. Finish your vest regular, after which cut off  $\frac{1}{4}$  inch from the front edge of the forepart all the way down, following the regular line as shown by those diagrams. After which proceed as follows: draw a straight line from 17 to Z; make the distance from Z to 14,  $1\frac{1}{2}$  inches or according to your own ideas; make the width at 16 about  $3\frac{1}{2}$  inches and draw a line as from 16 to 14. Add  $\frac{5}{8}$  inch in front of line 16-14 for the makeup of the edge and buttonholes.

Reshape the neck as from 1 through 17 down; add in front of 17-16 about  $\frac{1}{2}$  inch for two seams. This style of vest should be made with a collar. To make the collar for this style of vest proceed as follows: go down from 1 to 2,  $\frac{1}{4}$  of breast; square out from 2 to 4 by line 1-2; make the distance from 2 to 3 about  $1\frac{3}{4}$  inches and from 3 to 4 the width of the lapel desired; go up from 4 to 5 about 1 inch; from 2 to 6 is the same distance as from 2 to 3. Draw an imaginary line for a seam as from 3 to 6; now shape the collar as desired; this is shown so as to give an idea of about the proportionate length of the collar and lapel.

---

### DIAGRAM 129

After the rever is cut off place it to the forepart as at line Z and reshape the bottom as shown.



611-77  
113

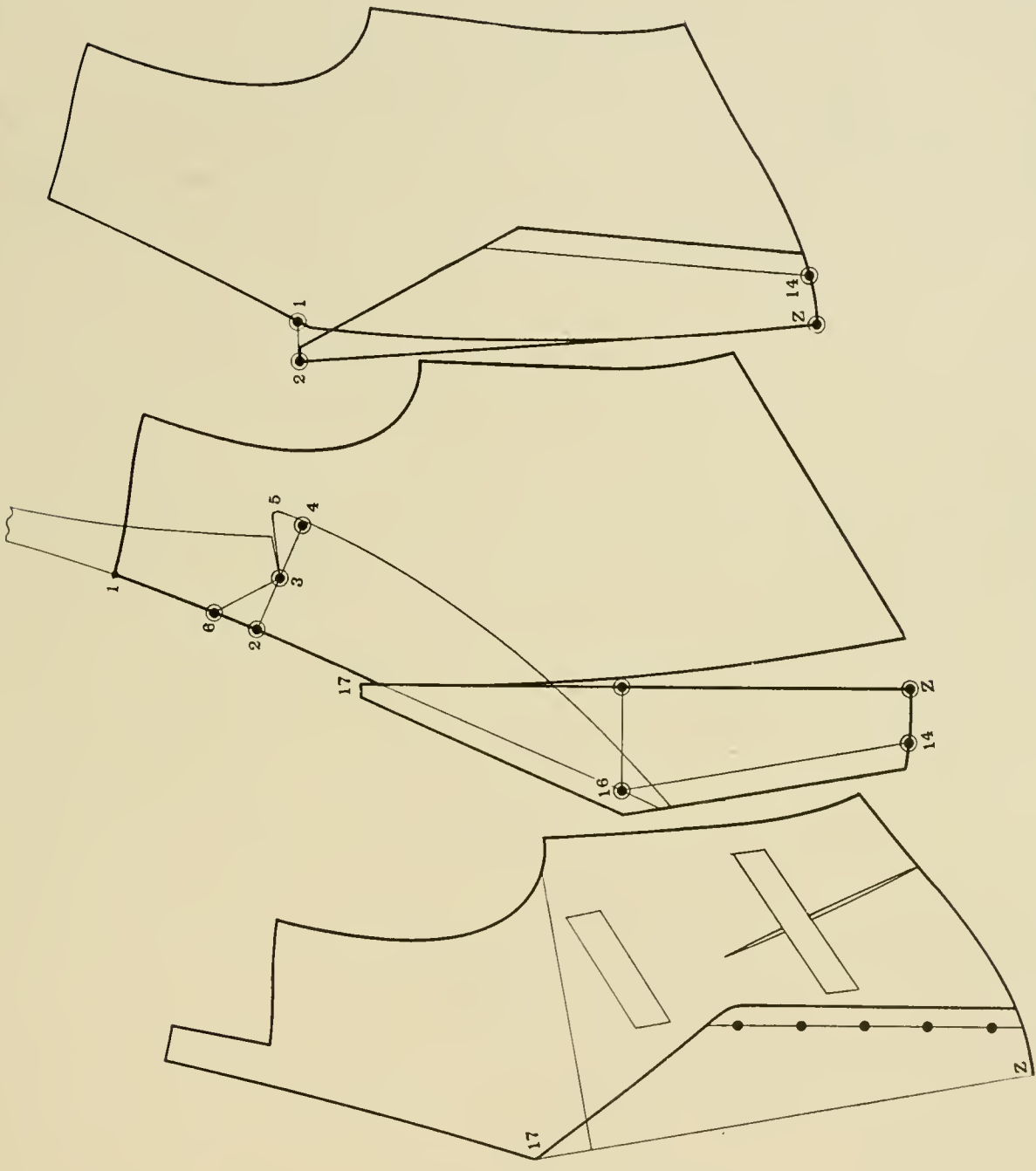

DIAGRAM 129

DIAGRAM 128

DIAGRAM 127

## DIAGRAM 130

## SINGLE-BREADED NO-COLLAR VEST FOR A STOUT FIGURE

The measurements are as follows:

Scye depth .....	9½ inches	Breast .....	40 inches
Waist length .....	17 inches	Waist .....	40 inches
Strap .....	13 inches	Opening .....	13½ inches
Overshoulder .....	18¼ inches	Full length .....	27½ inches
Blade .....	13½ inches		

Square down and out from A.

From A to B is the scye depth plus ¼ inch; C is waist length; C to D is 2¾ inches; E is halfway between A and B; F is halfway between A and E; square out from F, B, C and D.

From C to 2 is ¾ inch; draw a line from E to 2; from 1 to G is ½ breast; G to H is 1¼ inches; H to I is ¾ inch; square up a short line from 1; J is halfway between 1 and G; J to K is 3 inches; square down from K to locate L; apply the blade measure minus ½ inch from 1 to K, in this case, 13 inches and square up; X is halfway between 1 and K; X to 3 is ½ inch; square up from 3; this locates 20.

From 20 to W is 1 inch; A to S is 6⅜ inches; S to T is 1½ inches; draw a line from A to T; A to U is ½ breast; square up from U to locate V; draw a line from V to W; add ¼ inch to the back shoulder as at line 5-4, also add ¼ inch to the top of back; from L to M is ½ waist; N is halfway between L and M; O is halfway between K and H; draw a line from N through O up; A to 5 and K to P is the strap measure plus ¾ inch; draw a line from P to W; from P to R is ⅜ inch less than 5 to 4; go forwards ¾ inch from K and square up; shape the shoulder and armseye.

Square forwards from P by line N-O; P to Q is 1 inch; P to 11 is ¼ inch less than A to 5 on the backpart; draw a line from 11 to Q and finish the neckpiece. From P to Y is ½ breast plus ½ inch; square forwards from O by line N-O; this locates 18; shape the front edge from Y through 18 and M down; apply the opening measure plus ¼ inch from 11 to the opening, also apply the full length of the waist coat plus ¾ inch from 11 to Z; from L to 6 is 1 inch; J to 12 is 1¼ inches; draw a line from 12 to 6 and shape the side and bottom of forepart.

Point 7 is halfway between 2 and 6; 7 to 8 is ¼ waist; 7 to 2 is ¼ waist plus ¾ inch; add ½ inch to the backpart at 10, also add ½ inch to the forepart at the same point, because the pocket will be cut open as at line 6, and two seams will have to come out of there.

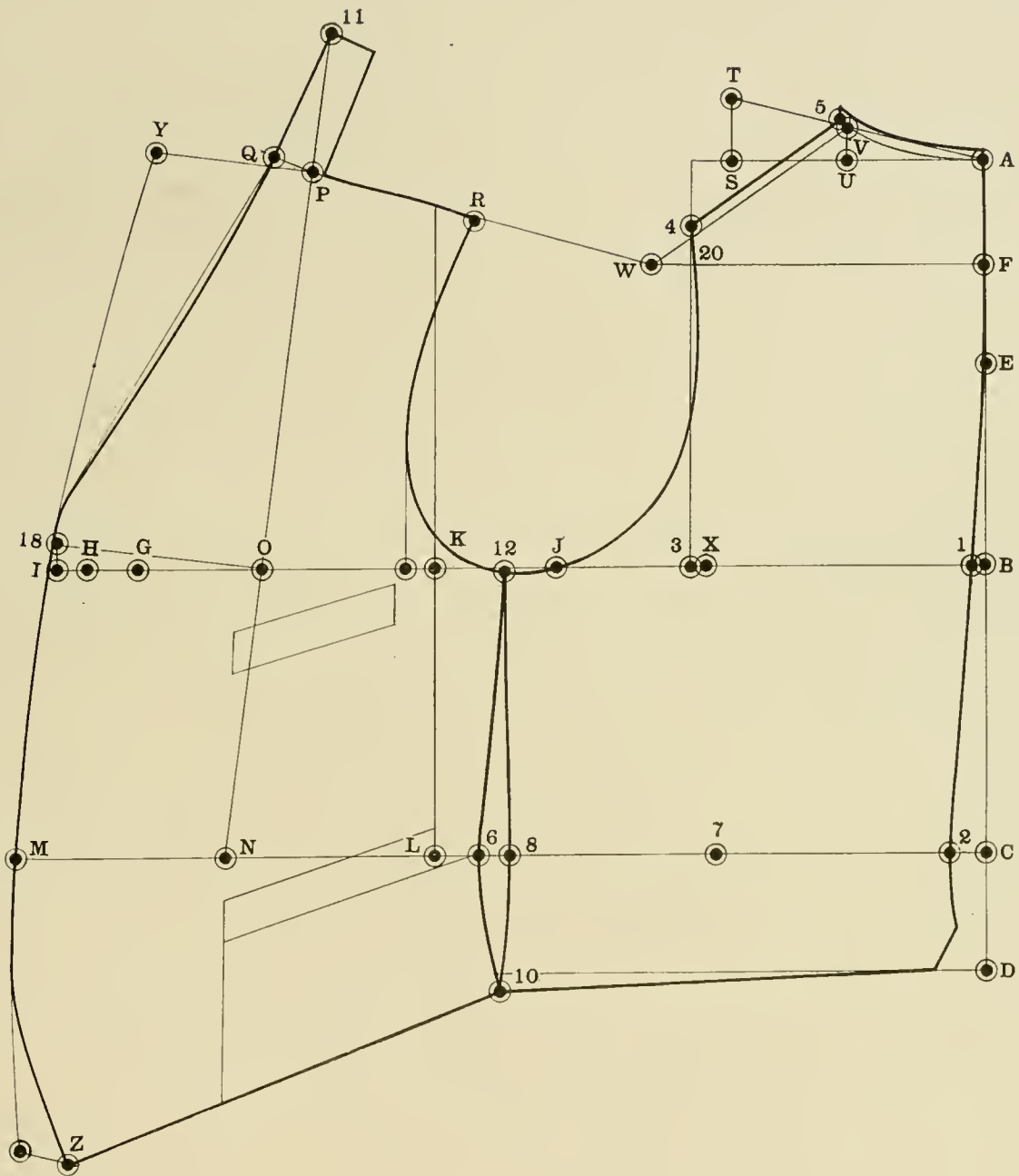

DIAGRAM 139

## DIAGRAM 131

After the forepart is cut out and the pocket is cut open, proceed as shown in diagram 131: overlap the forepart as from C to D about  $\frac{1}{2}$  inch, allowing it to open as between A and B; this will give the amount of convexity necessary to go over the stomach. Reshape the bottom.

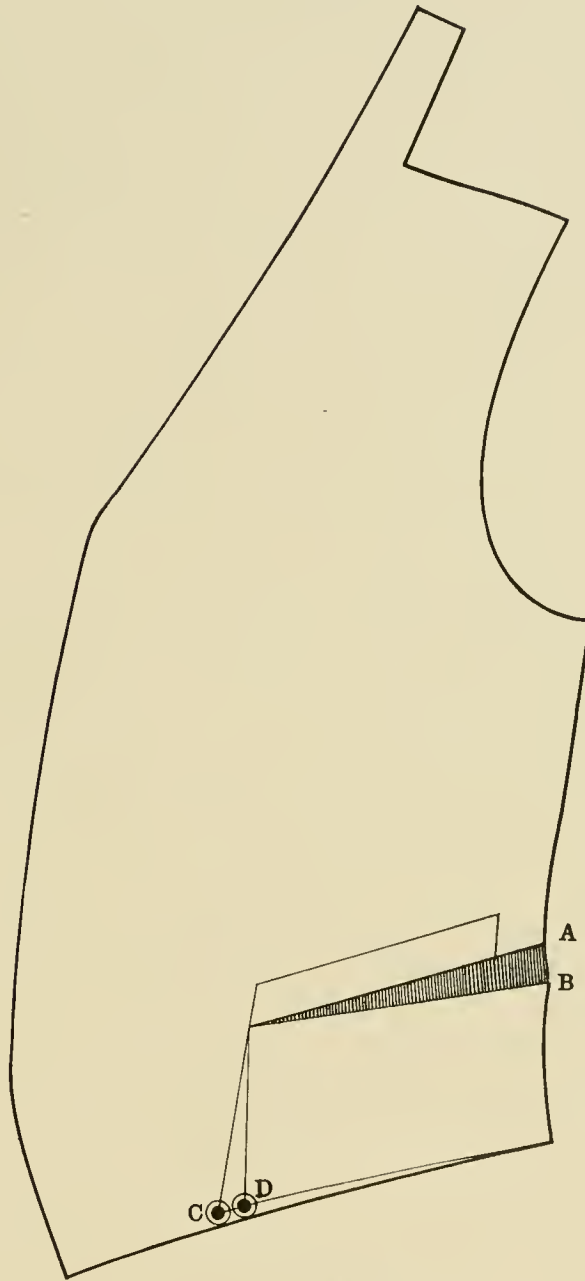

DIAGRAM 131

## DIAGRAM 132

## SINGLE-BREASTED WAISTCOAT FOR A CORPULENT FIGURE

The measurements are as follows:

Scye depth .....	9 $\frac{3}{4}$ inches	Breast .....	42 inches
Waist length .....	17 inches	Waist .....	44 inches
Strap .....	13 $\frac{1}{2}$ inches	Opening .....	14 inches
Overshoulder .....	19 inches	Full length .....	28 $\frac{1}{2}$ inches
Blade .....	14 inches		

Square down and out from A.

A to B is the scye depth plus  $\frac{1}{4}$  inch; C is waist length; C to D is 2 $\frac{3}{4}$  inches; E is halfway between A and B; F is halfway between A and E; square out from F, B, C and D.

C to 2 is  $\frac{3}{4}$  inch; draw a line from E to 2; from 1 to G is  $\frac{1}{2}$  breast; G to H is 1 $\frac{1}{4}$  inches; H to I is  $\frac{3}{4}$  inch; square up a short line from I; J is halfway between 1 and G; from J to K is 3 inches; square down from K to locate L; apply the blade measure minus  $\frac{1}{2}$  inch from 1 to K, in this case it is 13 $\frac{1}{2}$  inches and square up.

X is halfway between 1 and K; from X to 3 is  $\frac{1}{2}$  inch; square up from 3 to locate 20; 20 to W is 1 inch; from A to S is 6 $\frac{3}{8}$  inches; S to T is 1 $\frac{1}{2}$  inches; draw a line from A to T; A to U is  $\frac{1}{8}$  breast; square up from U to locate V; draw a line from V to W; add  $\frac{1}{4}$  inch to the shoulder as at 5-4, also  $\frac{1}{4}$  inch on top of back.

L to M is  $\frac{1}{2}$  waist; N is halfway between L and M; O is halfway between K and H; draw a line from N through O up; from A to 5 and K to P is the strap measure plus  $\frac{3}{4}$  inch; draw a line from P to W; from P to R is  $\frac{3}{8}$  inch less than from 5 to 4; shape the shoulder and armseye.

Square forwards from P by line N-O; also square forwards from O by same line; this locates 18; from P to Y is  $\frac{1}{8}$  breast plus  $\frac{1}{2}$  inch; shape the front edge from Y through 18 and M down; if the vest is to be with a collar, go out from P to Q  $\frac{3}{4}$  inch; if without a collar 1 inch; apply the opening measure plus  $\frac{3}{4}$  inch from A to 5 and P to the opening, also apply the full length measure plus 1 inch from A to 5 and P to Z.

From L to 6 is 1 inch; J to 12 is 1 $\frac{1}{4}$  inches; draw a line from 12 to 6 and shape the side and bottom of forepart; point 7 is halfway between 2 and 6; 7 to 8 is  $\frac{1}{4}$  waist; 7 back to 2 is  $\frac{1}{4}$  waist plus  $\frac{3}{4}$  inch; shape the center of back and also the side; add  $\frac{1}{2}$  inch to the backpart at 10 and finish.

For a corpulent man it is well to set a V in as shown at point 7; this will keep the backpart of the vest easy across the hip and give it the proper shape.

After the backpart is cut out, open the pocket and manipulate it in the same way as shown on diagram 131.

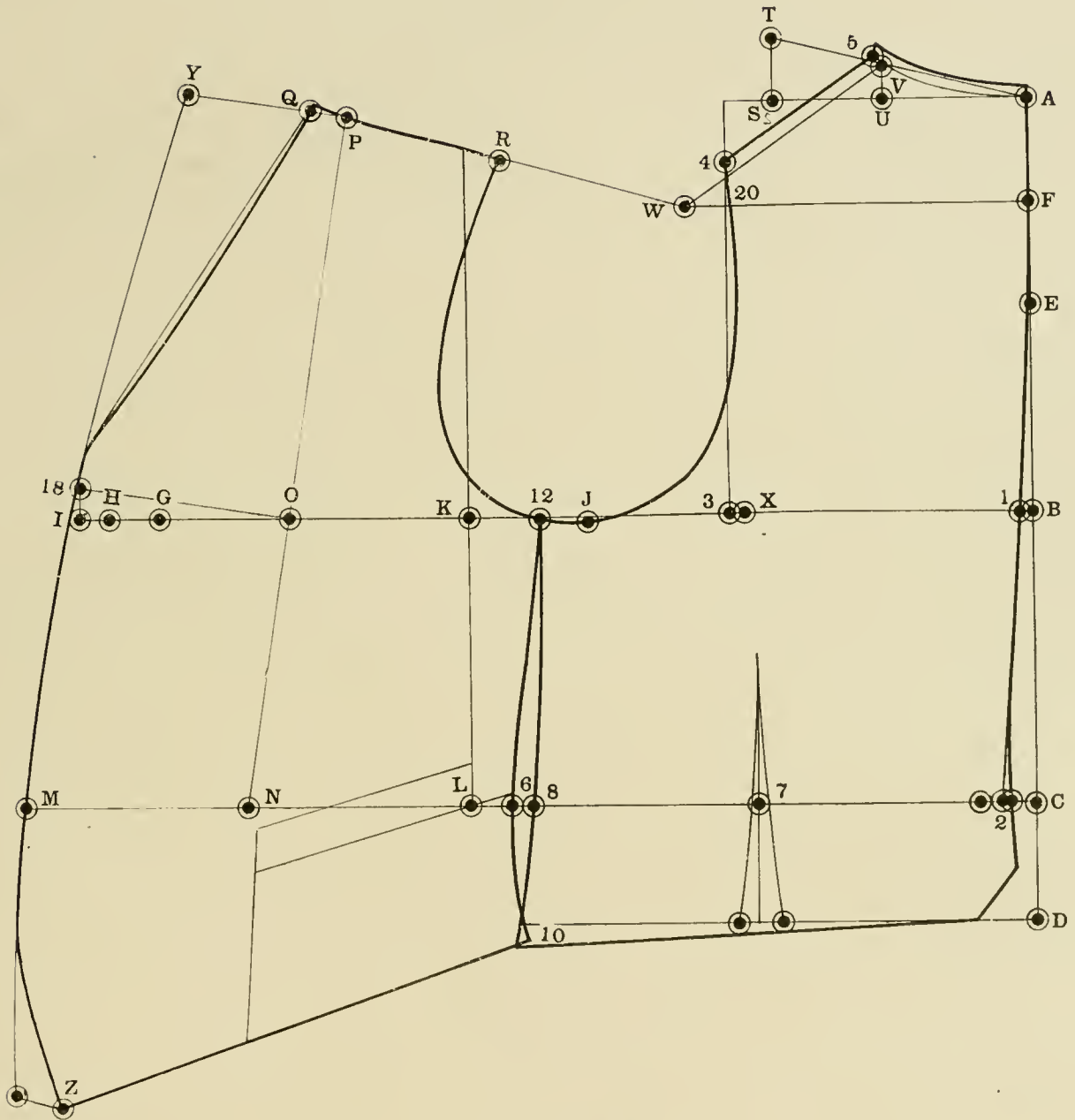

DIAGRAM 132

DIAGRAM 133  
DOUBLE-BREADED VEST FOR A STOUT FIGURE

The measurements are as follows:

Scye depth .....	9 $\frac{3}{4}$ inches	Breast .....	42 inches
Waist length .....	17 inches	Waist .....	12 inches
Strap .....	13 $\frac{1}{2}$ inches	Opening .....	13 inches
Overshoulder .....	19 inches	Full length .....	28 $\frac{1}{2}$ inches
Blade .....	14 inches		

Square down and out from A.

A to B is the scye depth plus  $\frac{1}{4}$  inch; C is waist length; C to D is 2 $\frac{3}{4}$  inches; E is halfway between A and B; F is halfway between A and E; square out from F, B, C and D.

C to 2 is  $\frac{3}{4}$  inch; draw a line from E to 2; from 1 to G is  $\frac{1}{2}$  breast; G to H is 1 $\frac{1}{4}$  inches; H to I is  $\frac{1}{4}$  inch; square up a short line from 1; J is halfway between 1 and G; J to K is 3 inches; square down from K to locate L; apply the blade measure minus  $\frac{1}{2}$  inch from 1 to K and square up; X is halfway between 1 and K; X to 3 is  $\frac{1}{2}$  inch; square up from 3 to locate 20; 20 to W is 1 inch; from A to S is 6 $\frac{3}{8}$  inches; S to T is 1 $\frac{1}{2}$  inches; draw a line from A to T.

From A to U is  $\frac{1}{8}$  breast; square up from U to locate V; draw a line from V to W; add  $\frac{1}{4}$  inch to the shoulder as at 5-4, also add  $\frac{1}{4}$  inch to the top of back; from L to M is  $\frac{1}{2}$  waist; point N is halfway between L and M; point O is halfway between K and H; draw a line from N through O up; from A to 5 and K to P is the strap measure plus  $\frac{3}{4}$  inch; draw a line from P to W; from P to R is  $\frac{3}{8}$  inch less than 5 to 4; shape the shoulder and armseye.

Square forwards from P by line N-O also square forwards from O by the same line; this locates 18; from P to Q is 1 inch; from P to 11 is  $\frac{1}{4}$  inch less than A to 5 on the backpart; draw a line from 11 to Q and finish the neckpiece.

From M back to 19 is  $\frac{1}{2}$  inch; draw a line from 18 through 19 down; apply the opening measure plus  $\frac{1}{4}$  inch from 11 to the opening, also apply the full length measure plus  $\frac{3}{4}$  inch from 11 to Z; draw a line from Q through the opening down; make the width from Z to 14 and 15 to 16 according to style, also add  $\frac{5}{8}$  inch in front of line 16-11 for the making up of the edge and the buttonholes.

From L back to 6 is 1 inch; J to 12 is 1 $\frac{1}{4}$  inches; shape the side of forepart from 12 through 6 down; also add  $\frac{1}{2}$  inch to the forepart and backpart at 10; point 7 is halfway between 2 and 6; from 7 to 8 is  $\frac{1}{4}$  waist; from 7 to 2 is  $\frac{1}{4}$  waist plus  $\frac{3}{4}$  inch; cut out the forepart and backpart; cut in the pocket as at 6 and manipulate the pattern the same as shown on diagram 134.



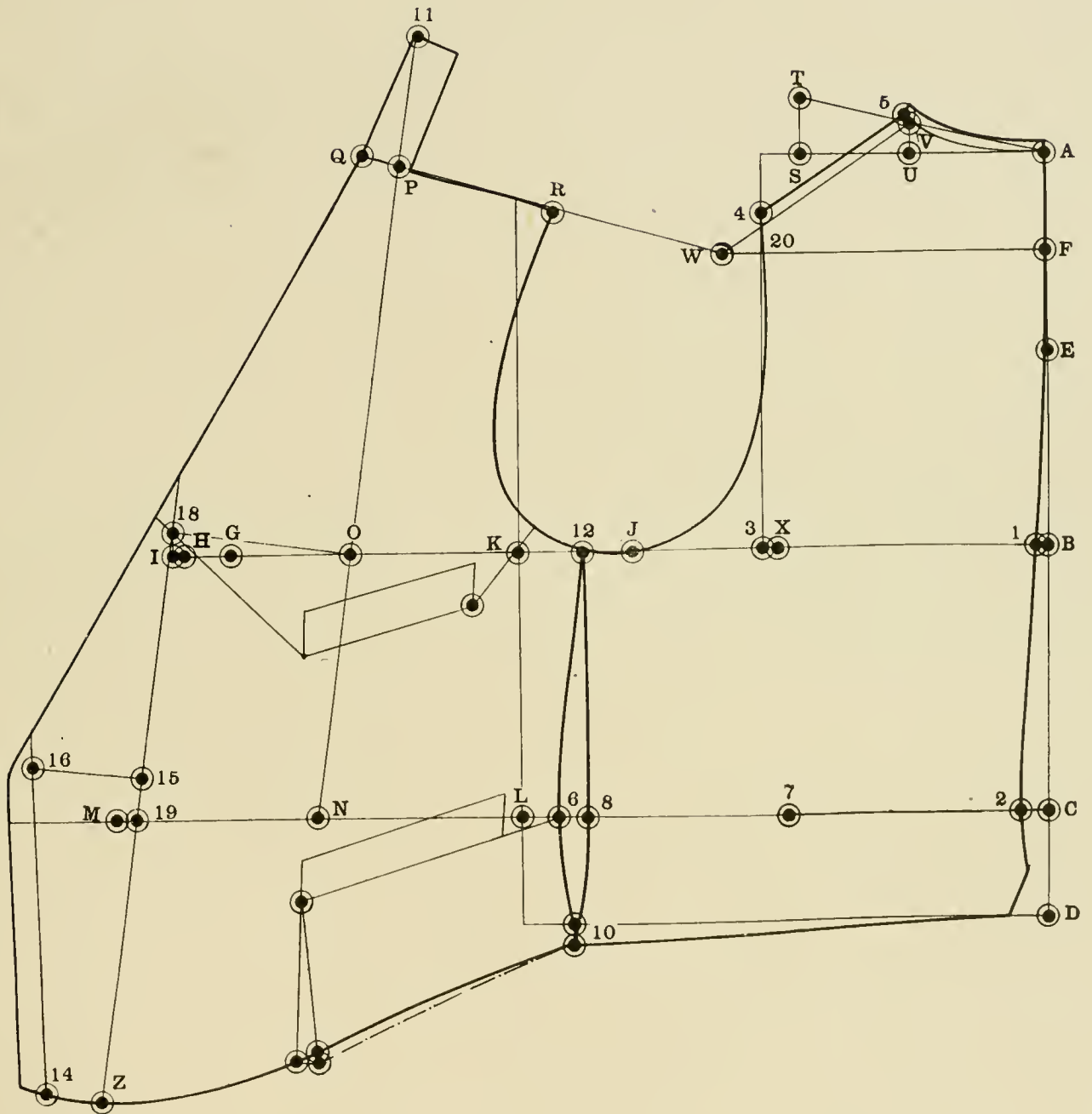

DIAGRAM 133

## DIAGRAM 134

In cutting a double-breasted waistcoat for a stout figure it is well, besides overlapping the forepart as between 1 and 2, to cut in the breast pocket as from 9 to 10; open the pocket as from 10 to 7 and overlap it as between 5 and 6 about  $\frac{3}{8}$  inch, after which add a seam to lines 8 and 9; this will not alone work around over the stomach but will also shorten the neck line so as to keep the opening from being loose.

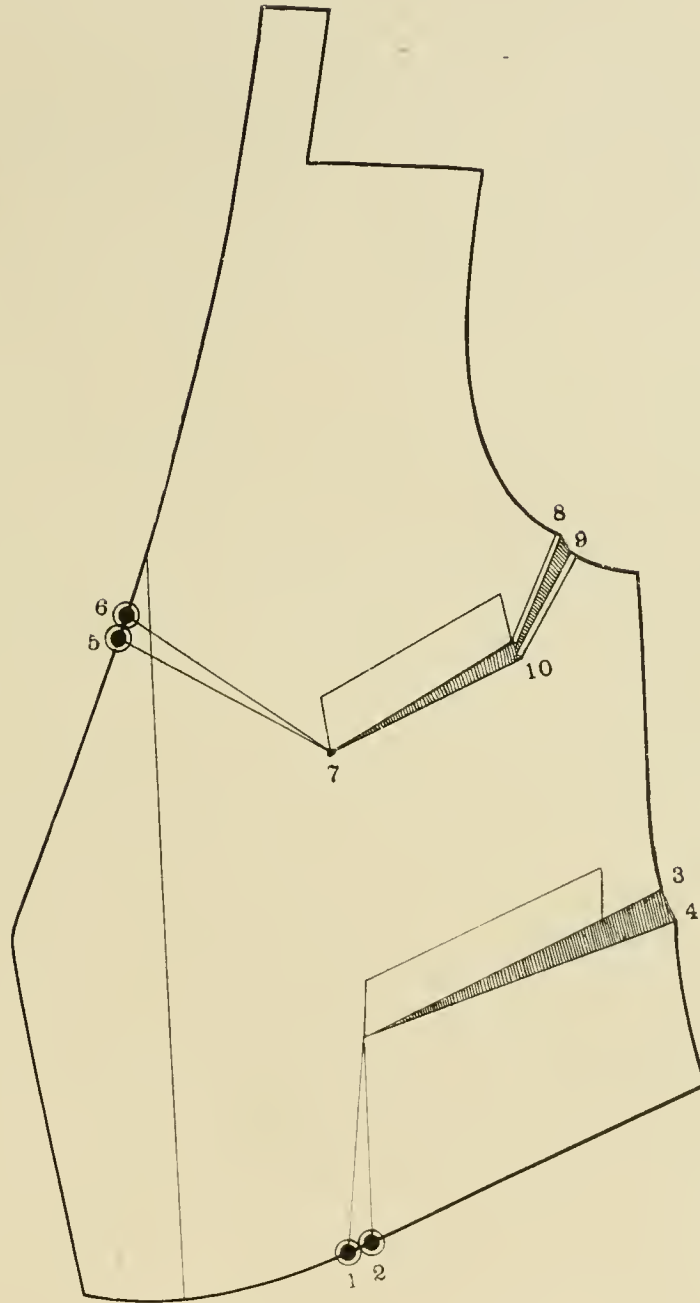

DIAGRAM 134

DIAGRAM 135  
SINGLE-BREADED DRESS WAISTCOAT

The measurements are as follows:

Scye depth .....	9 inches	Breast .....	36 inches
Waist length .....	16½ inches	Waist .....	32 inches
Strap .....	12 inches	Opening according to style	
Overshoulder .....	17 inches	Full length .....	25½ inches
Blade .....	12½ inches		

Square down and out from A.

From A to B is the scye depth plus ¼ inch; C is waist length; C to D is 2¾ inches; E is halfway between A and B; F is halfway between A and E; square out from F, B, C and D.

From C to 2 is ¾ inch; draw a line from E to 2; 1 to G is ½ breast; G to H is 1¼ inches; H to I is ¾ inch; J is halfway between 1 and G; J to K is 3 inches; square down from K to locate L; apply the blade measure minus ½ inch from 1 to K, in this case 12 inches and square up; X is halfway between 1 and K; X to 3 is ½ inch; square up from 3 to locate 20; 20 to W is 1 inch; A to S is 6¾ inches; S to T is 1½ inches; draw a line from A to T.

From A to U is ¾ breast; square up from U to locate V; draw a line from V to W; add ¼ inch to the shoulder as at 5-4, also add ¼ inch to the top of back; L to M is ½ waist; point N is halfway between L and M; point O is halfway between K and H; draw a line from N through O up; from A to 5 and K to P is the strap measure plus ¾ inch draw a line from P to W; from P to R is ¾ inch less than 5 to 4; go forwards ¾ inch from K and square up; shape the shoulder and armseye.

From P to Q is 4 inch; apply the opening measure plus ¾ inch from A to 5 and from P to wherever the opening comes, also full length plus 1 inch from A to 5 and P to Z; shape the front edge from 1 through M down; from M back to Y is ¾ breast; draw a line from Y to Q; shape the opening, adding a little round to the straight line as shown in this diagram; from L to 6 is 1 inch; J to 12 is 1¼ inches; shape the side and bottom of forepart.

Point 7 is halfway between 2 and 6; from 7 to 8 is ¼ waist; 7 to 9 is ¼ waist plus ¾ inch; shape the center and sideseam of backpart and finish.

The collar, like all other waistcoat collars, is cut flat; no stand.

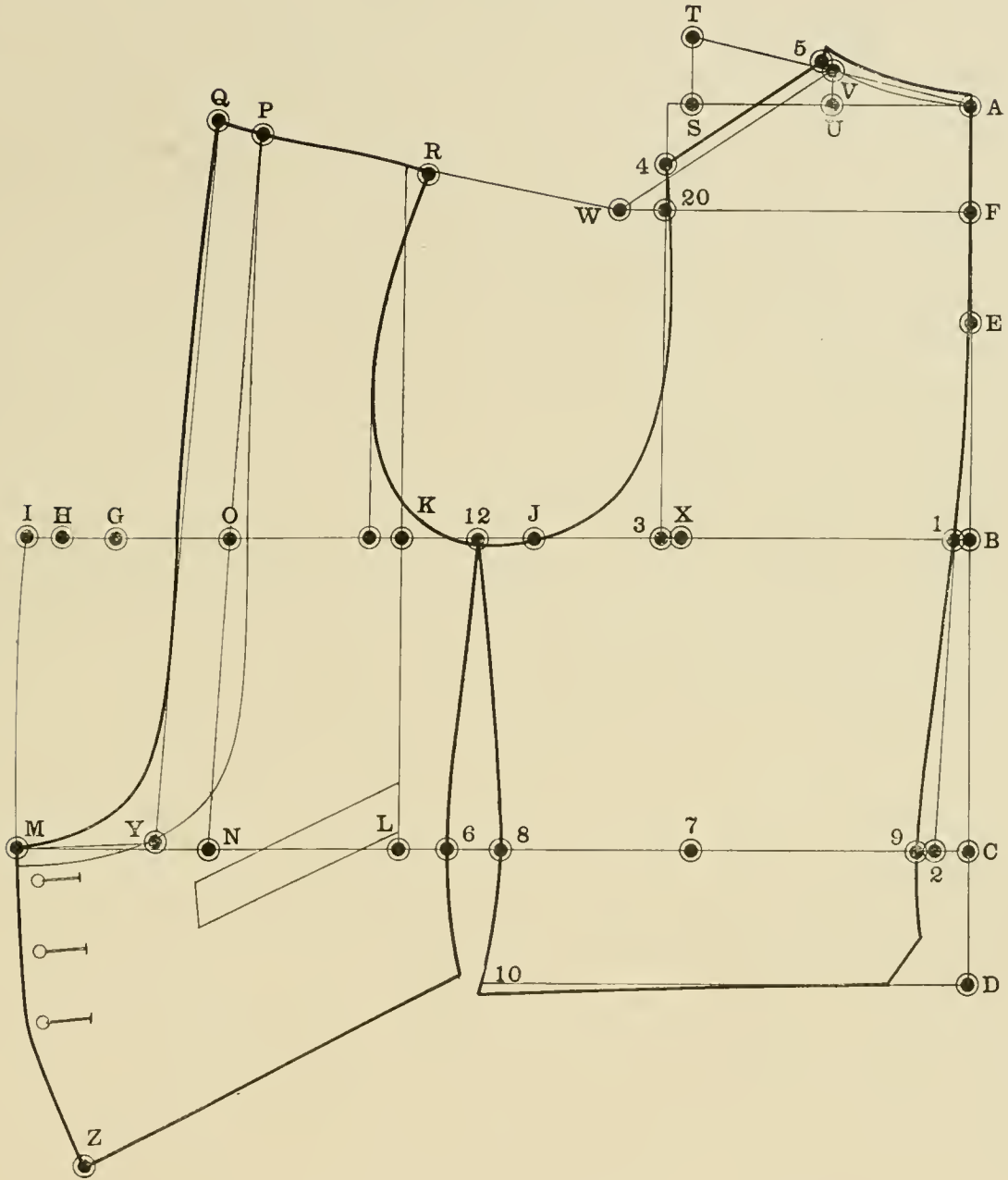

DIAGRAM 135

## DIAGRAM 136

## DOUBLE-BREADED DRESS WAISTCOAT

As shown in this diagram this waistcoat is made as follows: line A-C is the regular edge of a single-breasted waistcoat; go back from A to B  $\frac{1}{2}$  inch and from C to D the same; draw a straight line from B through D down; this locates the center line; from Z to 14 is  $1\frac{1}{4}$  inches; Y to 15 is  $2\frac{1}{2}$  inches; draw a line from 15 through 14; add  $\frac{5}{8}$  inch in front of line 14-15 for the makeup of the edge and buttonholes.

Measure the opening plus  $\frac{3}{4}$  inch the same as shown in the other waistcoat; go back from line C to 16,  $\frac{1}{6}$  breast; draw a line up to the side of the neck point; reshape as shown, after which crease over the front part on the center line B-Z and reshape the bottom the same as shown on diagram 127.

## DIAGRAM 137

This diagram shows how to make a double-breasted waistcoat with a V shaped front. Line A-D is the center line of forepart; from A to B is  $2\frac{1}{2}$  inches; D to E is  $3\frac{1}{2}$  inches; draw a line from B through E; add  $\frac{5}{8}$  inch for makeup in front of line B-E and reshape the front; crease over as at line A-E and mark the buttons and buttonholes as shown.

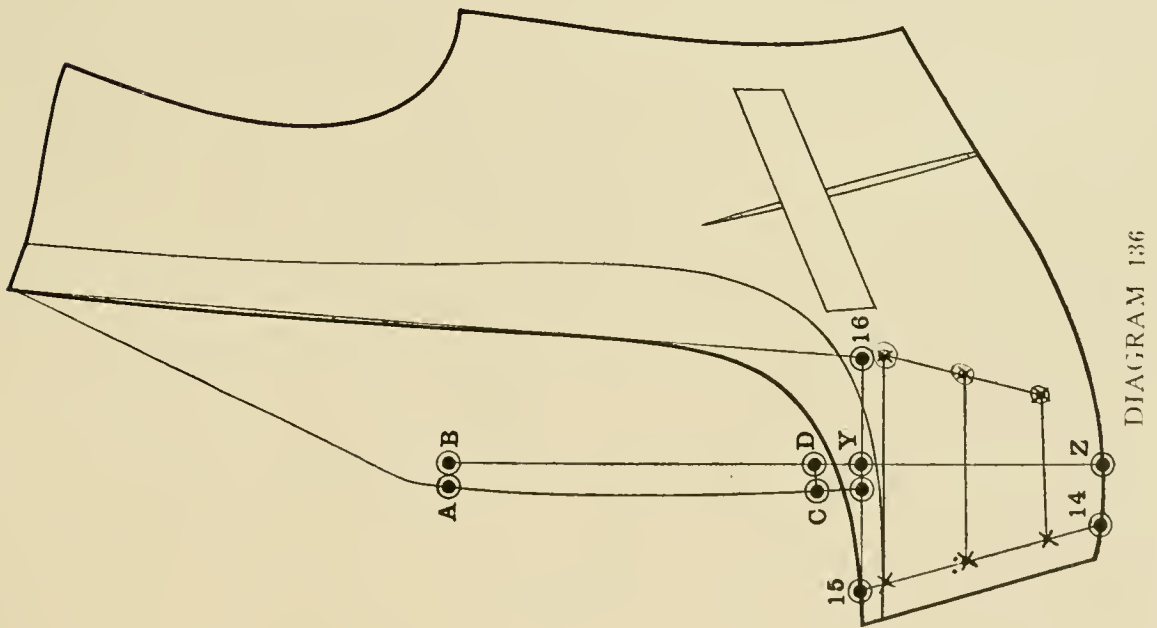
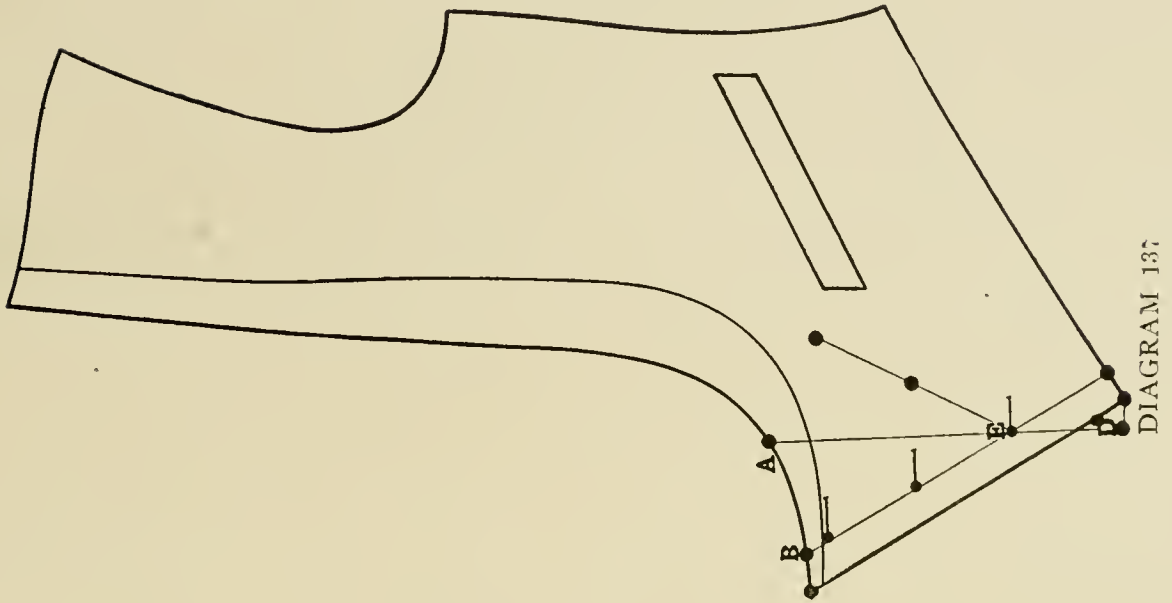

## DIAGRAM 138

## CLERGYMAN'S WAISTCOAT

As the measurements for waistcoats are invariably the same, it is not necessary to repeat same in each case. Therefore the measurements for this waistcoat are the same as in previous diagrams.

Square down and out from A.

From A to B is the scye depth plus  $\frac{1}{4}$  inch; C is waist length; C to D is  $2\frac{3}{4}$  inches; E is halfway between A and B; F is halfway between A and E; square out from F, B, C and D.

C to 2 is  $\frac{3}{4}$  inch; draw a line from E to 2; from 1 to G is  $\frac{1}{2}$  breast; G to H is  $1\frac{1}{4}$  inches; H to I is  $\frac{3}{4}$  inch; J is halfway between 1 and G; J to K is 3 inches; square down from K to locate L; apply the blade measure minus  $\frac{1}{2}$  inch from 1 to K and square up; X is halfway between 1 and K; from X to 3 is  $\frac{1}{2}$  inch; square up from 3 to locate 20; from 20 to W is 1 inch; A to S is  $6\frac{3}{8}$  inches; S to T is  $1\frac{1}{2}$  inches; draw a line from A to T.

From A to U is  $\frac{1}{6}$  breast; square up from U to locate V; draw a line from V to W; add  $\frac{1}{4}$  inch to the shoulder as at 5-4, also add  $\frac{1}{4}$  inch to the top of back; from L to M is  $\frac{1}{2}$  waist; point N is halfway between L and M; point O is halfway between K and H; draw a line from N through O up; from A to 5 and K to P is the strap measure plus  $\frac{3}{4}$  inch; draw a line from P to W; from P to R is  $\frac{3}{8}$  inch less than 5 to 4; go forwards  $\frac{3}{4}$  inch from K and square up; shape the shoulder and armhole.

Square forwards from P by line N-O; P to Y is  $\frac{1}{6}$  breast plus  $\frac{1}{2}$  inch; shape the front edge from Y through I and M down; from Y to Q is  $\frac{3}{4}$  inch less than  $\frac{1}{6}$  breast; P to 11 is  $\frac{1}{4}$  inch less than  $\frac{1}{8}$  breast; draw a line from 11 to Q and shape the gorge; add on a seam at the gorge as at P-Q; apply the full length measure plus 1 inch from A to 5 and P down; L to 6 is 1 inch; J to 12 is  $1\frac{1}{4}$  inches; shape the side and bottom of forepart; point 7 is halfway between 2 and 6; 7 to 8 is  $\frac{1}{4}$  waist; 7 to 9 is  $\frac{1}{4}$  waist plus  $\frac{3}{4}$  inch; shape the center and sideseam of back.

## THE COLLAR

From Q to 12 is  $\frac{1}{2}$  inch; draw a line from 12 through P; from 12 to 13 is 1 inch more than  $\frac{1}{2}$  of the shirt collar size; shape the collar from 13 into the gorge line; from 13 to 14 is the height of the collar desired; make the distance from 12 up the same as from 13 to 14; shape the collar and finish.



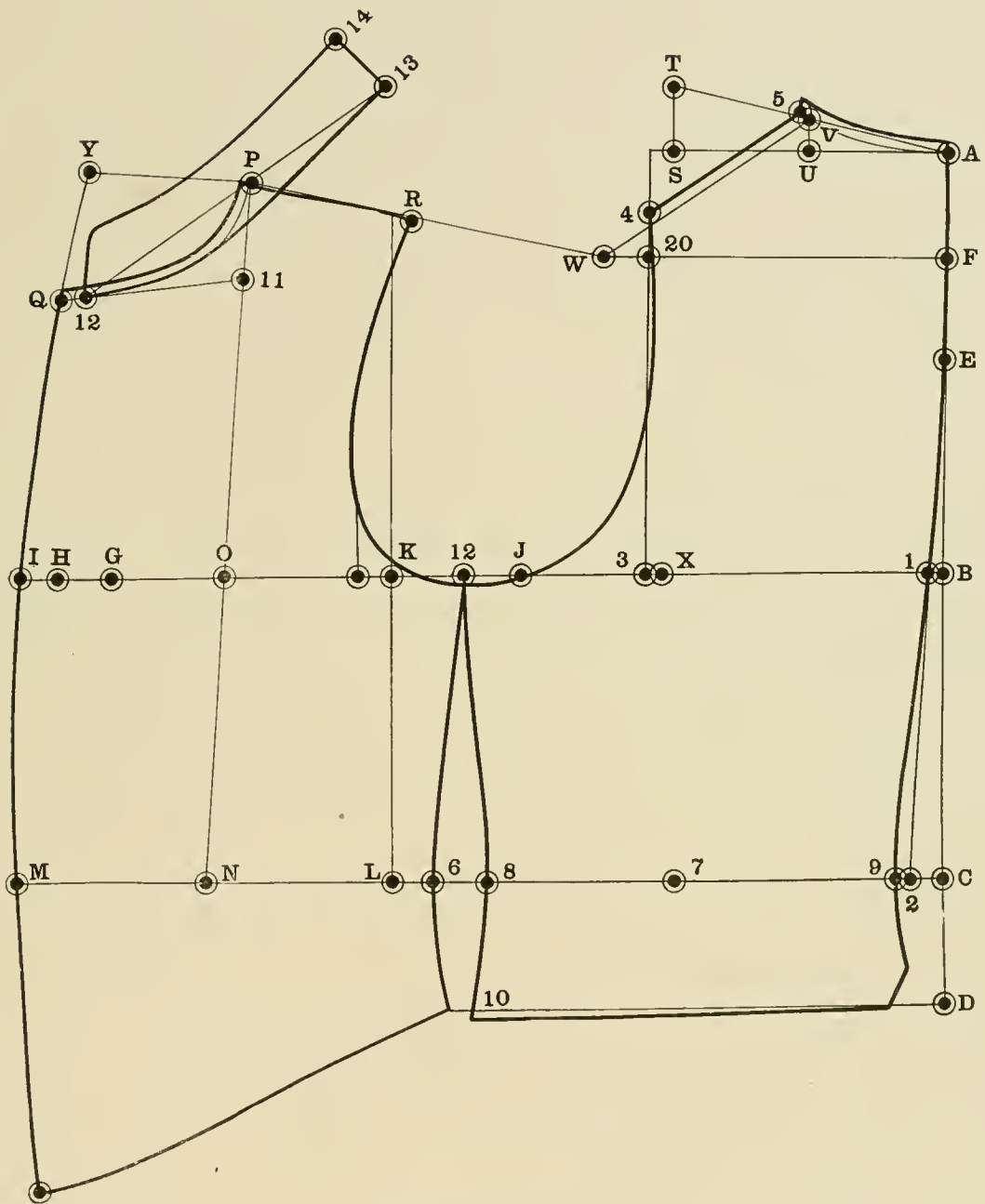

DIAGRAM 138

## DIAGRAMS 139 &amp; 140

These diagrams show how a clergyman's waistcoat may be made to button on the side with a seam in the center front. Diagram 139: after the regular waistcoat has been cut out as explained in diagram 138, cut off from the front edge  $\frac{1}{4}$  inch as from 1 to 2 and 3 to 4. Place the front pattern on a piece of paper and mark around the side, shoulder and armhole as shown on this diagram; draw a line as from 5 to 6 and cut out the extra piece.

Diagram 140 represents the extra piece that has been traced out and this is to be used for the button stand and the buttonholes are to be placed on the side of the front part.

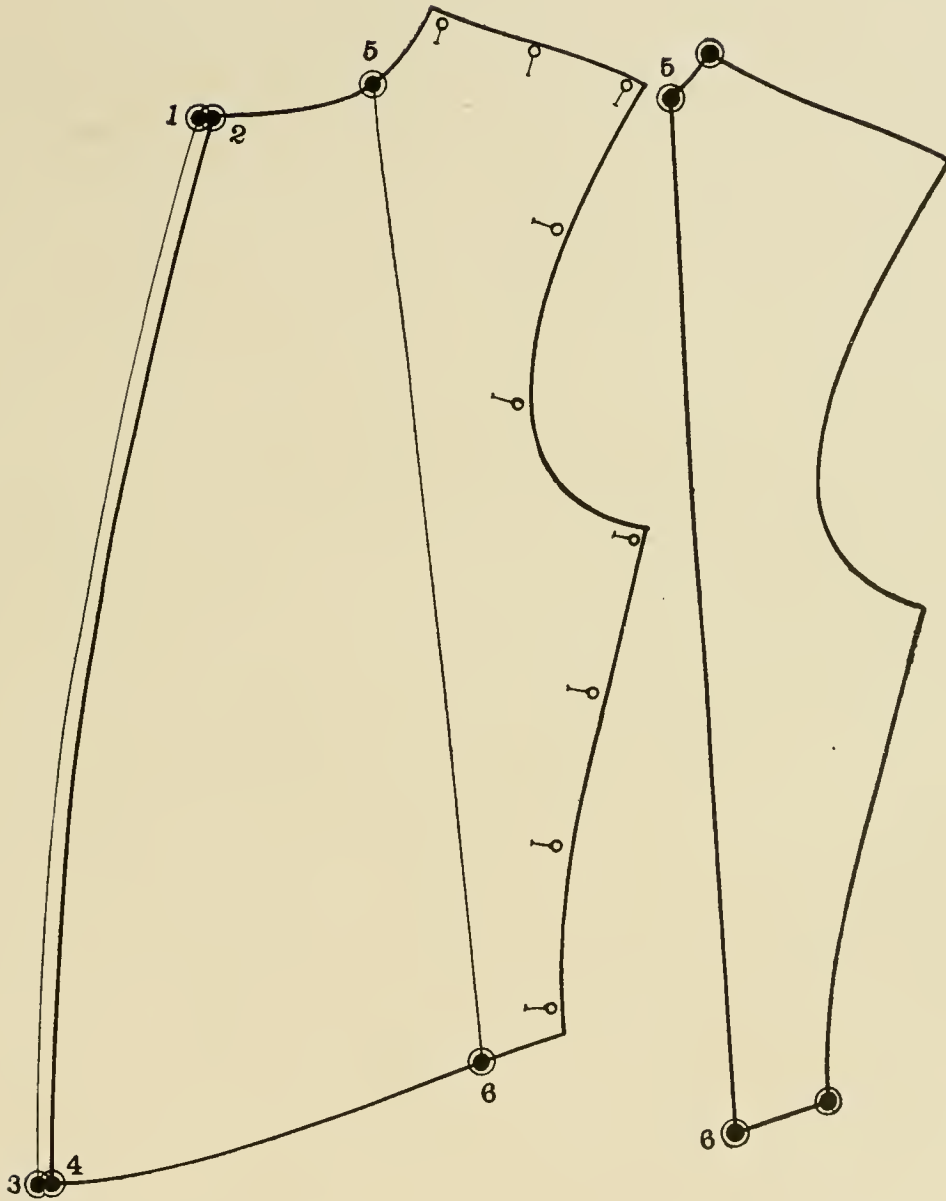

DIAGRAM 139

DIAGRAM 140

## DIAGRAMS 141 &amp; 142

These two diagrams show how the same waistcoat is to be made without a seam in front. From 1 back to 2 is  $\frac{1}{2}$  inch and 3 back to 4 is the same; shape the front edge as from 2 through D down to 4 and square down from 4 by the waistline; cut out a small fish from the lower pocket as shown. This will allow the line from 4 to be squared down by the waist, after which mark your breast pocket and proceed as follows: split the front part as from A to B, B to C and C to D.

(Diagram 142.) Keep the two parts of the forepart close at C; overlap at D until the front edge can be made into a straight line; add a seam as at A-B as shown on this diagram and finish. Nothing is to be added on to the pocket. When these parts, A and B are sewn together, also the lower fish is sewn, the front will have the proper amount of roundness and can be made up on the fold without a seam in front.

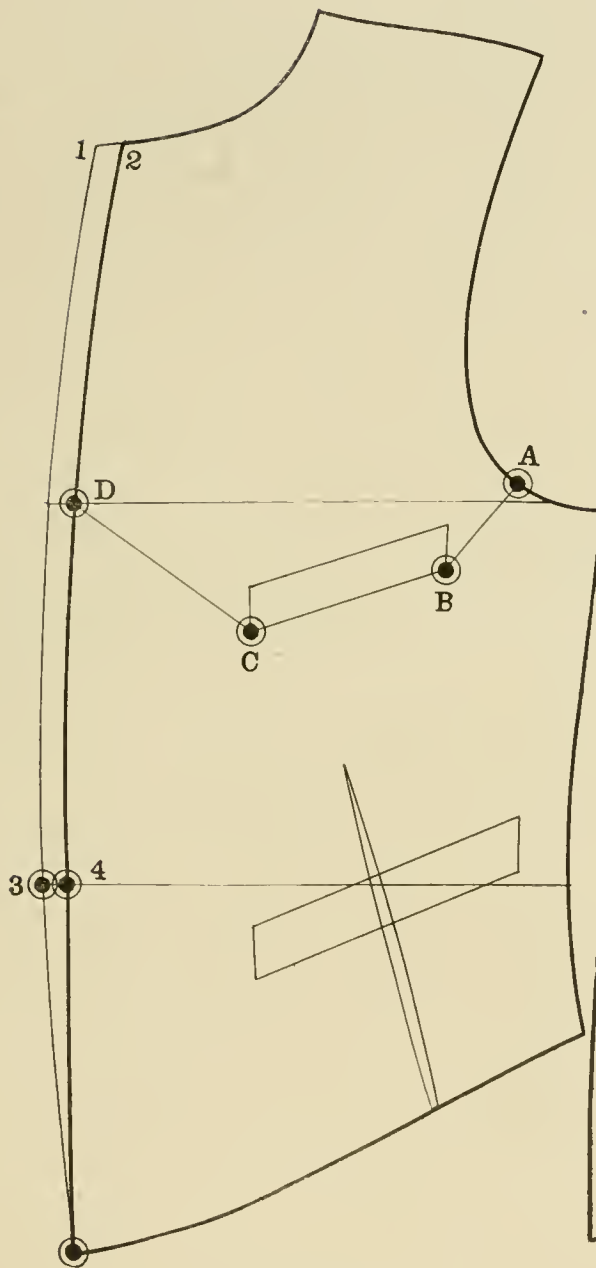

DIAGRAM 141

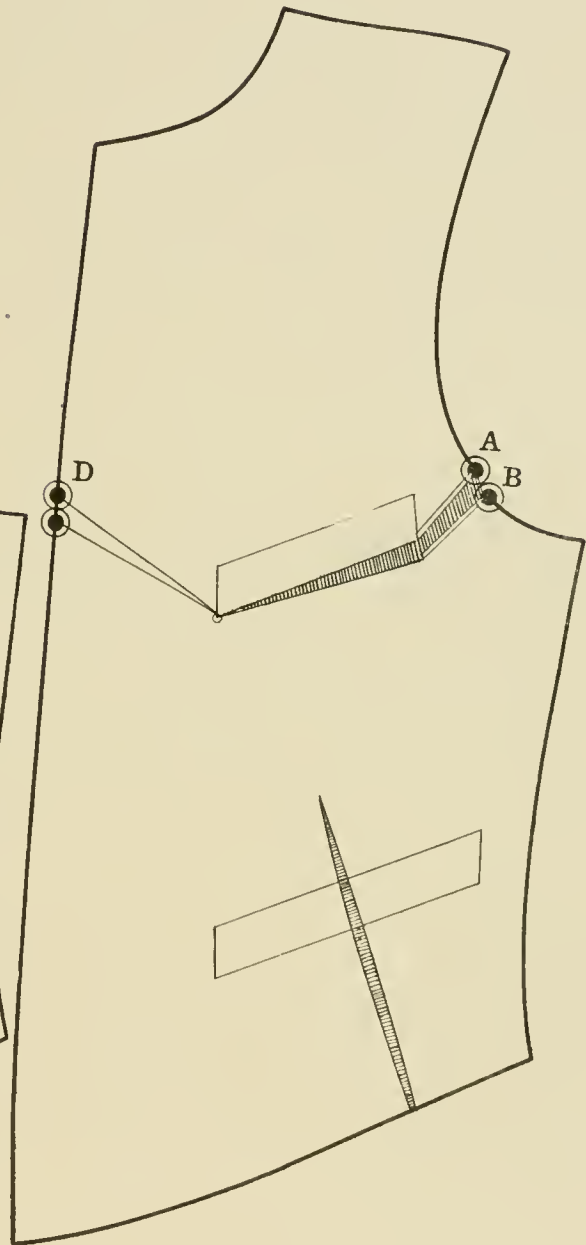

DIAGRAM 142

## DIAGRAM 143

## SINGLE-BREADED WAISTCOAT FOR A HUNCH-BACK

The measurements are as follows:

Scye depth .....	8 inches	Breast .....	38 inches
Waist length .....	$16\frac{3}{4}$ inches	Waist .....	36 inches
Strap .....	11 inches	Opening .....	12 inches
Overshoulder .....	$16\frac{3}{4}$ inches	Full length .....	25 inches
Blade .....	13 inches		

Square down and out from A.

From A to B is the scye depth plus  $\frac{1}{4}$  inch; C is waist length; C to D is  $2\frac{3}{4}$  inches; E is halfway between A and B; F is halfway between A and E; square out from F, B, C and D.

From C to 2 is  $\frac{3}{4}$  inch; draw a line from E to 2; from 1 to G is  $\frac{1}{2}$  breast; G to H is  $1\frac{1}{4}$  inches; H to I is  $\frac{3}{4}$  inch; J is halfway between 1 and G; J to K is 3 inches; square down from K to locate L; apply the blade measure minus  $\frac{1}{2}$  inch from 1 to K which is  $12\frac{1}{2}$  inches and square up; X is halfway between 1 and K; X to 3 is  $\frac{1}{2}$  inch; square up from 3 to locate 20; from 20 to W is 1 inch; A to S is  $6\frac{3}{8}$  inches; S to T is  $1\frac{1}{2}$  inches; draw a line from A to T.

From A to U is  $\frac{1}{2}$  breast; square up from U to locate V; draw a line from V to W; add on  $\frac{1}{4}$  inch to the shoulder as at 5-4, also add  $\frac{1}{4}$  inch to the top of back; from L to M is  $\frac{1}{2}$  waist; N is halfway between L and M; O is halfway between K and H; draw a line from N through O up; from A to 5 and K to P is the strap measure plus  $\frac{3}{4}$  inch; draw a line from P to W; from P to R is  $\frac{3}{8}$  inch less than 4 to 5; go forwards  $\frac{3}{4}$  inch from K and shape the shoulder and armseye.

Now apply the overshoulder measure plus 1 inch from 1 to 4 and from K up; the overshoulder measure reaches up to 10, in this case the distance between 13 and 10 is  $1\frac{1}{4}$  inches, the overshoulder therefore is  $1\frac{1}{4}$  inches short. Proceed as follows: add from 4 to 9,  $1\frac{1}{4}$  inches; from 5 to 11 the same; go in from 1 to 14,  $1\frac{1}{4}$  inches; draw a line from 14 to E; point 15 begins at line A-T; now shape the backpart from 15 to 1 and from 15 to 11, 11 to 9 and from 9 into the armseye. Measure the distance from 11 to 9 and make the distance from P to R,  $\frac{3}{8}$  inch less; from L to 6 is 1 inch; point 7 is halfway between 2 and 6; 7 to 8 is  $\frac{1}{4}$  waist; 7 to 2 is  $\frac{1}{4}$  waist plus  $\frac{3}{4}$  inch; J to 12 is  $1\frac{1}{4}$  inches; shape the sideseams of the backpart and forepart.

Now apply the opening measure plus  $\frac{3}{4}$  inch from 15 to 11 and P to I and the full length plus 1 inch from 15 to 11 and P to Z; shape the front edge and finish.

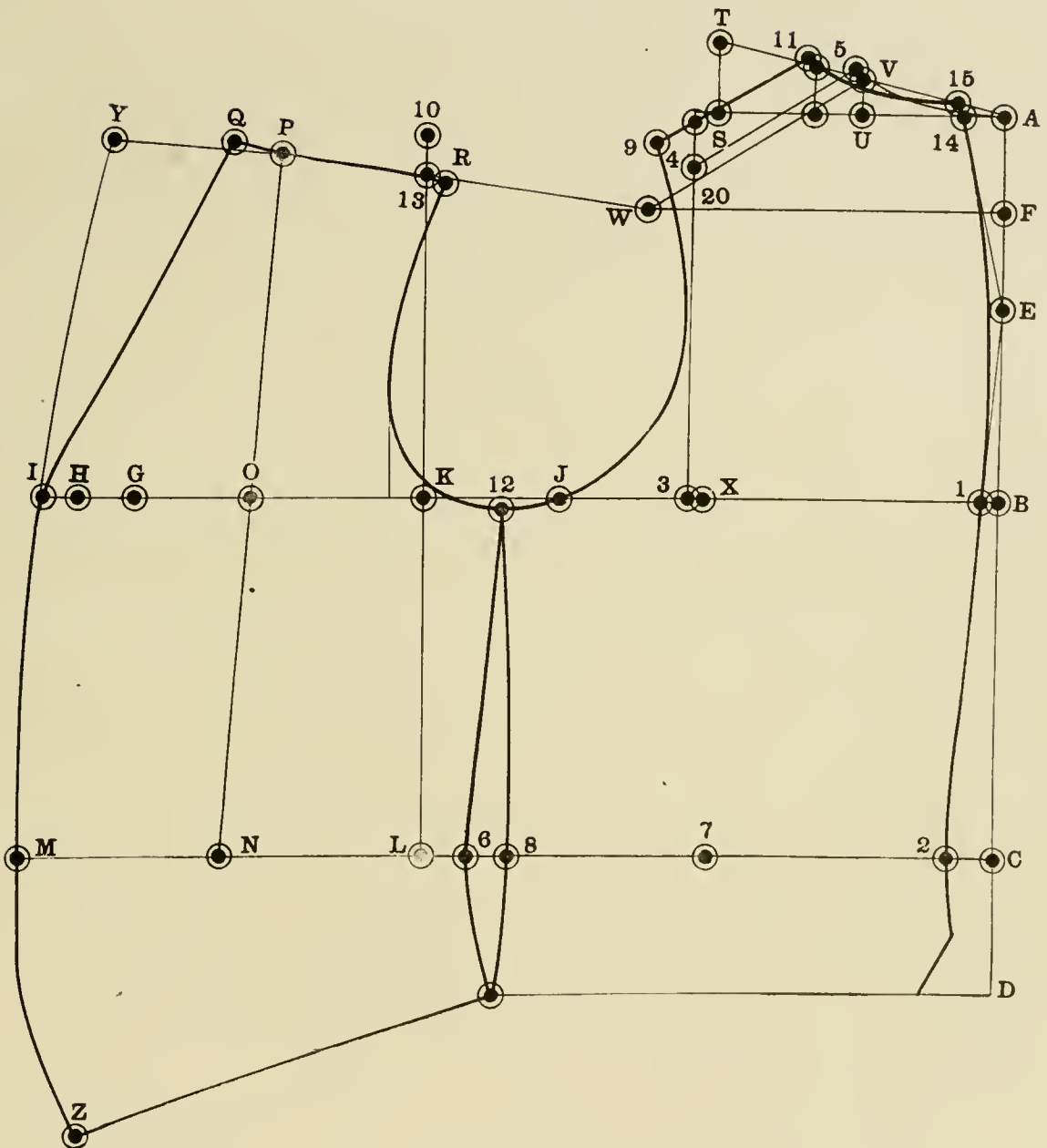

DIAGRAM 143

## DIAGRAMS 144 &amp; 145

## TROUSERS

Measurements for trousers should be taken in the following manner: the outside length should be taken from the hip bone down to the top of heel, minus  $\frac{3}{4}$  inch for regular trousers. If the trousers are to be very narrow, the measurements may be made minus 1 inch. Loose leg trousers may always be made slightly longer than tight leg trousers; the inseam should be taken from the crotch down to the top of the heel minus the same amount as has been reduced on the outside seam. The waist measure should be taken  $\frac{1}{2}$  inch closer than the natural measure because the measurements are taken over the trousers and the trousers will be worn over the underwear. The seat measure should be taken natural, neither too loose nor too tight and knee and bottom should be taken according to style.

The measurements for diagram 144 are as follows:

Outside length .....	42 inches	Seat .....	38 inches
Inseam .....	$32\frac{1}{2}$ inches	Knee .....	19 inches
Waist .....	32 inches	Bottom .....	$16\frac{1}{2}$ inches

Square down and out from A.

From A to B is the outside length; from B to C is the inseam plus  $\frac{1}{4}$  inch; B to E is  $\frac{1}{2}$  inseam plus 2 inches; C to D is  $\frac{1}{6}$  seat; square out from D, C, E and B; from C to F is  $\frac{1}{2}$  seat; from F to 1 is 5-16 inch and F to 2 is the same, or make the distance from 1 to 2,  $\frac{5}{8}$  inch; from 1 to G is  $\frac{1}{8}$  seat; G back to H is  $\frac{3}{4}$  inch; K is halfway between C and H.

From B to L is the same distance as from C to K; draw a line from L through K up; from L to T is  $\frac{1}{4}$  inch less than  $\frac{1}{4}$  bottom; L to S is the same; M to R is  $\frac{1}{4}$  knee; M to Q is the same; draw a line from T through Q up; this locates J; sweep from J to G pivoting at Q; from N to O is  $\frac{1}{4}$  waist; N to P is the same; draw a line from S to R and from R to C; shape the front part as shown.

## THE BACKPART

**Diagram 145.** Extend lines S-T-R-Q; from S to W is  $\frac{1}{2}$  inch; T to V is  $1\frac{1}{2}$  inches; Q to U is 1 inch; sweep from G to 7 pivoting at Q; from G to 7 is  $1\frac{5}{8}$  inches; from R back to H is 1 inch; R to 12 is the same; sweep from C backwards pivoting at H; sweep from D to 10 pivoting at H; sweep from P to 3 pivoting at 12; 4 to 5 is 1 inch; square up from 5; place the square to points E-6 until the right angle lays on 3 and square both ways; this locates point 8.

From 8 to 9 is  $\frac{1}{2}$  seat; 9 to 10 is  $1\frac{1}{2}$  inches; draw a line from R through 10 up; hollow the side seam of the backpart slightly between 10 and 12; from 6 to X is  $\frac{1}{2}$  waist; X to Y is  $1\frac{1}{2}$  inches for six seams, including the V; whatever is left between Y and 3 is to be cut out as a V at X and Z; sweep from X to Z pivoting at 1; shape the backpart as shown and finish.



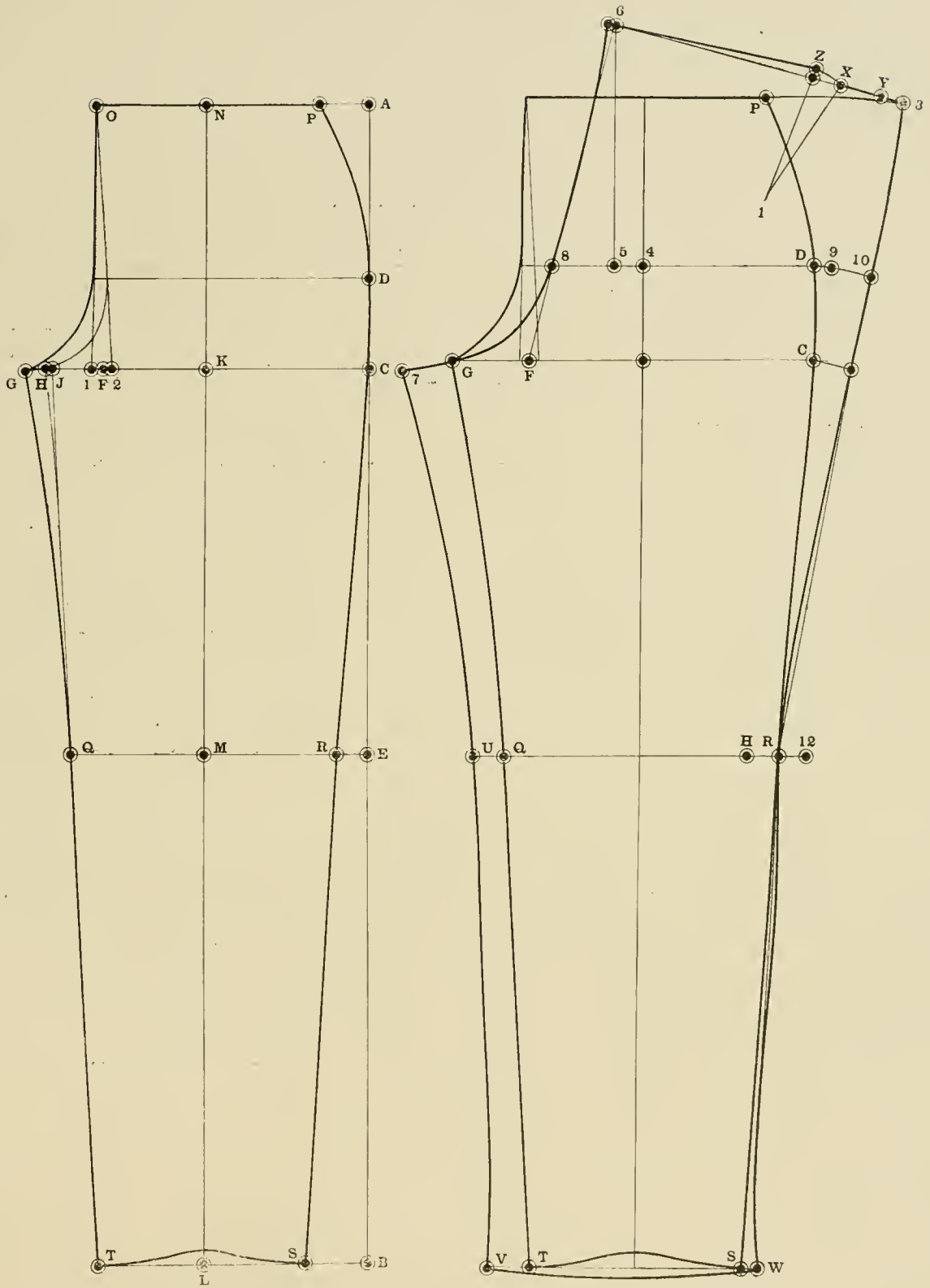

DIAGRAM 144

DIAGRAM 145

## DIAGRAMS 146 &amp; 147

## STOUT MAN'S TROUSERS

The measurements are as follows:

Outside length .....	42½ inches	Seat .....	44 inches
Inseam .....	32 inches	Knee .....	21 inches
Waist .....	42 inches	Bottom .....	16½ inches

Square down and out from A.

From A to B is the outside length; B to C is the inseam plus  $\frac{1}{4}$  inch; B to E is  $\frac{1}{2}$  inseam plus 2 inches; from C to D is  $\frac{1}{8}$  seat; square out from D, C, E and B.

From C to F is  $\frac{1}{2}$  seat; F to 1 is  $\frac{5}{16}$  inch and 1 to 2 is  $\frac{5}{8}$  inch; from 1 to G is  $\frac{1}{8}$  seat; G back to H is  $\frac{3}{4}$  inch; point K is halfway between C and H; B to L is the same distance as from C to K; draw a line from L through K up; from L to T is  $\frac{1}{4}$  inch less than  $\frac{1}{4}$  bottom; L to S is the same; M to Q is  $\frac{1}{4}$  knee; M to R is the same; draw lines from T through Q up; this locates J; sweep from J to G pivoting at Q, also draw a line from S to R and R to C.

From N to O is  $\frac{1}{4}$  waist; N to P is the same; draw lines from O to 1 and from O to 2; place the square to points C-1 with the right angle touching at 13; whatever the distance is from 13 to O, go up the same distance from 13 to 14; now draw a line from P through 14 and shape the forepart as shown.

## THE BACKPART

**Diagram 147.** Extend lines S-T and Q-R; from S to W is  $\frac{1}{2}$  inch; T to V is  $1\frac{1}{2}$  inches; Q to U is 1 inch; sweep from G to 7 pivoting at Q; from G to 7 is  $1\frac{5}{8}$  inches; from R to H is 1 inch; R to 12 is the same; sweep from C backwards pivoting at H; sweep from D to 10 pivoting at H; sweep from P to 3 pivoting at 12; from 4 to 5 is 1 inch; square up from 5; place the square to points F-6 until the right angle touches the sweep as at 3 and mark both ways; this locates 8.

From 8 to 9 is  $\frac{1}{2}$  seat; 9 to 10 is  $1\frac{1}{2}$  inches; draw a line from R through 10 up to 3; from 6 to X is  $\frac{1}{2}$  waist; X to Y is  $1\frac{1}{2}$  inches for seams; whatever is left between Y and 3 cut out as a V at Z; shape the backpart and finish.



DIAGRAM 146

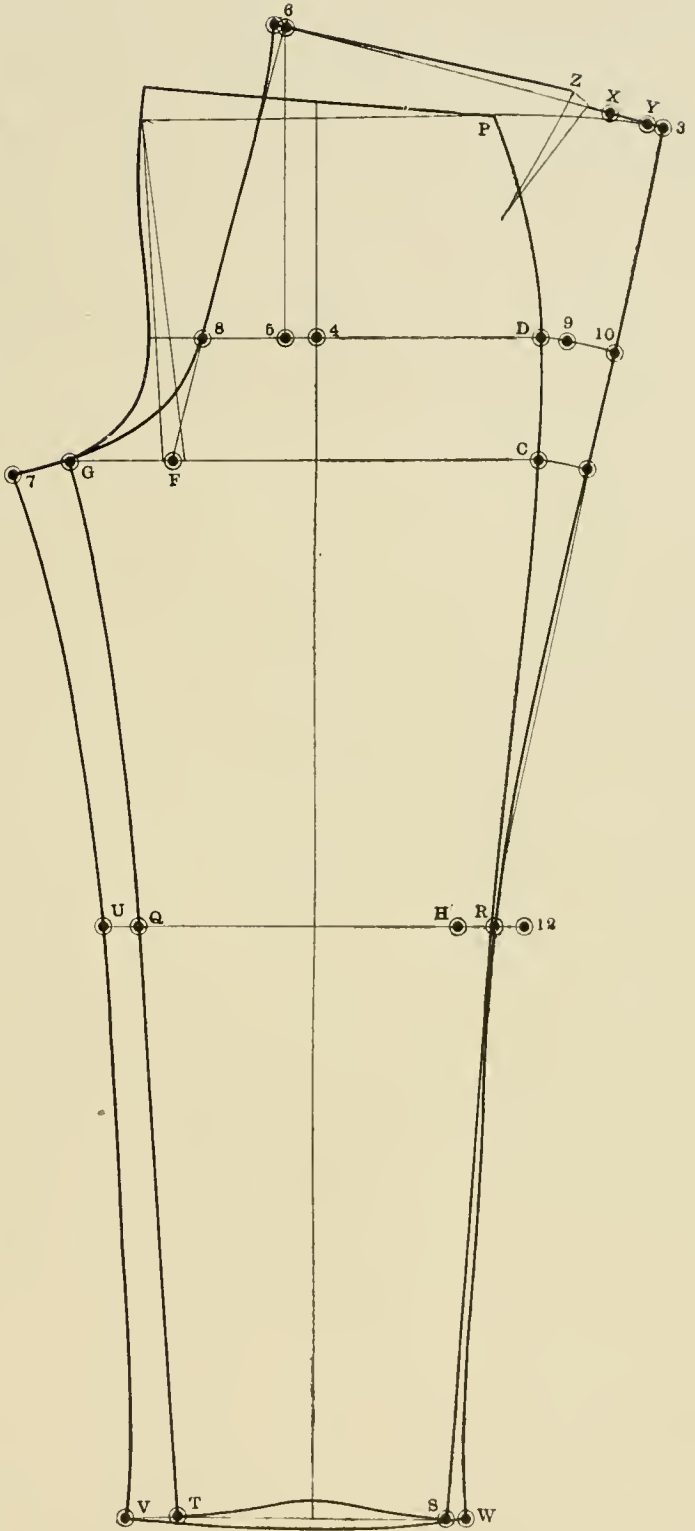

DIAGRAM 147

## DIAGRAM 148

## PEG-TOP TROUSERS

The measurements are as follows:

Outside length .....	41 inches	Seat .....	38 inches
Inseam .....	32 inches	Knee .....	21 $\frac{1}{2}$ inches
Waist .....	30 inches	Bottom .....	16 inches

Square down and out from A.

From A to B is the outside length; B to C is the inseam plus  $\frac{1}{4}$  inch; B to E is  $\frac{1}{2}$  inseam plus 2 inches; C to D is  $\frac{1}{6}$  seat; square out from D, C, E and B.

From C to F is  $\frac{1}{2}$  seat; F to J is 5.16 inch; J to 2 is  $\frac{5}{8}$  inch; J to G is  $\frac{1}{8}$  seat; G back to H is  $\frac{3}{4}$  inch; K is halfway between C and H; from B to L is the same distance as from C to K; draw a line from L through K up; L to T is  $\frac{1}{4}$  inch less than  $\frac{1}{4}$  bottom; L to S is the same; draw a line from T to H; this locates Q; sweep from H to G pivoting at Q; from Q to E is  $\frac{1}{2}$  knee; draw a line from S through E up.

From N to O is  $\frac{1}{4}$  waist; N to P is the same; draw lines from O to 1 and O to 2; add from C to 9 as much as desired and shape the sideseam from P through 9 to E.

## THE BACKPART

Extend lines T-S, Q-E, H-C, 4-D and O-P; from 4 to 5 is 1 $\frac{1}{2}$  inches; square up from 5; this locates J; from J to 3 is  $\frac{1}{2}$  seat plus  $\frac{1}{2}$  inch; place the square to points F-6 until the right angle touches at 3; this locates 8; from 8 to 10 is  $\frac{1}{2}$  seat plus 1 $\frac{1}{2}$  inches; draw a straight line from S through 10 up; S to W is  $\frac{1}{2}$  inch; T to V is 1 $\frac{1}{2}$  inches; Q to U is 1 inch; sweep from G to 7 pivoting at Q; G to 7 is 1 $\frac{5}{8}$  inches; apply the waist measure plus 1 $\frac{1}{2}$  inches for seams and 1 inch for a V and shape the backpart as shown, adding about  $\frac{3}{4}$  inch rounding at 12.

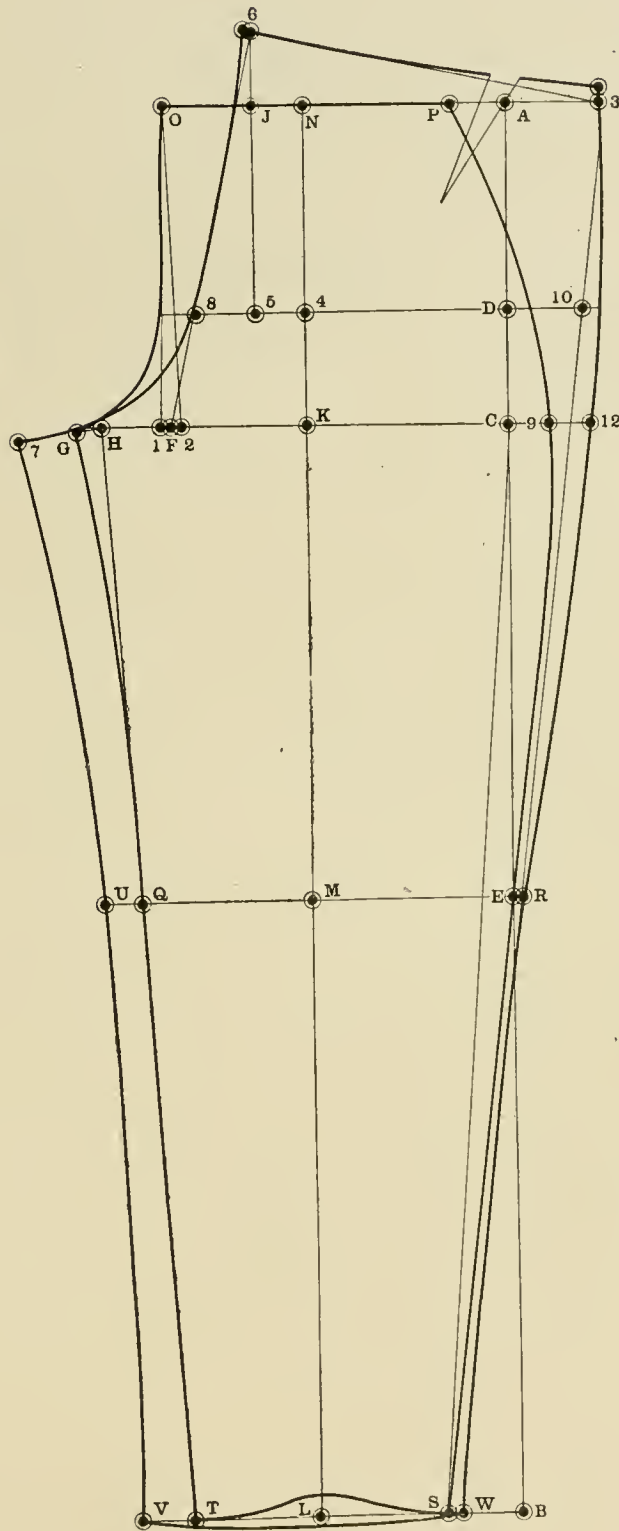

DIAGRAM 148

## DIAGRAM 149

This diagram shows a pair of trousers with large legs, without being peg-top.

The measurements are as follows.

Outside length .....	42	inches	Seat .....	40	inches
Inseam .....	32½	inches	Knee .....	22	inches
Waist .....	34	inches	Bottom .....	16½	inches

Square down and out from A.

From A to B is the outside length; B to C is the inseam plus  $\frac{1}{4}$  inch; B to E is  $\frac{1}{2}$  inseam plus 2 inches; C to D is  $\frac{1}{6}$  seat; square out from D, C, E and B.

From C to F is  $\frac{1}{2}$  seat; F to 1 is  $\frac{5}{16}$  inch; 1 to 2 is  $\frac{5}{8}$  inch; from 1 to G is  $\frac{1}{8}$  seat; G back to H is  $\frac{3}{4}$  inch; K is halfway between C and H; B to L is the same distance as from C to K; draw a line from L through K up; from L to T is  $\frac{1}{4}$  inch less than  $\frac{1}{4}$  bottom; L to S is the same; draw a line from T to H; this locates Q; sweep from H to G pivoting at Q, also draw a straight line from S to C; this locates R. From N to O is  $\frac{1}{4}$  waist; N to P is the same; draw lines from O to 1 and O to 2 and shape the forepart.

## THE BACKPART

Extend lines S-T and Q-R; from R to H is 1 inch; R to E is the same; from S to W is  $\frac{1}{2}$  inch; T to V is  $1\frac{1}{2}$  inches; from Q to U is 1 inch; sweep from G to 7 pivoting at Q; from G to 7 is  $1\frac{5}{8}$  inches; sweep from C backwards pivoting at H; sweep from D to 10 pivoting at H; sweep from P to 3 pivoting at E; apply the knee measure plus 1 inch from Q to R and U to 12.

Divide the distance between 12 and R in half; this locates E; from U to 13 is the same distance as from 12 to E; shape the inseam from 7 through 13 to V; from 4 to 5 is 1 inch; square up from 5; place the square to points F-6 until the right angle touches the sweep at 3; this locates 8.

From 8 to 10 is  $\frac{1}{2}$  seat plus  $1\frac{1}{2}$  inches; draw a line from R through 10 up; shape the outside seam from 10 through E to W and finish the backpart the same as shown on the previous diagram.

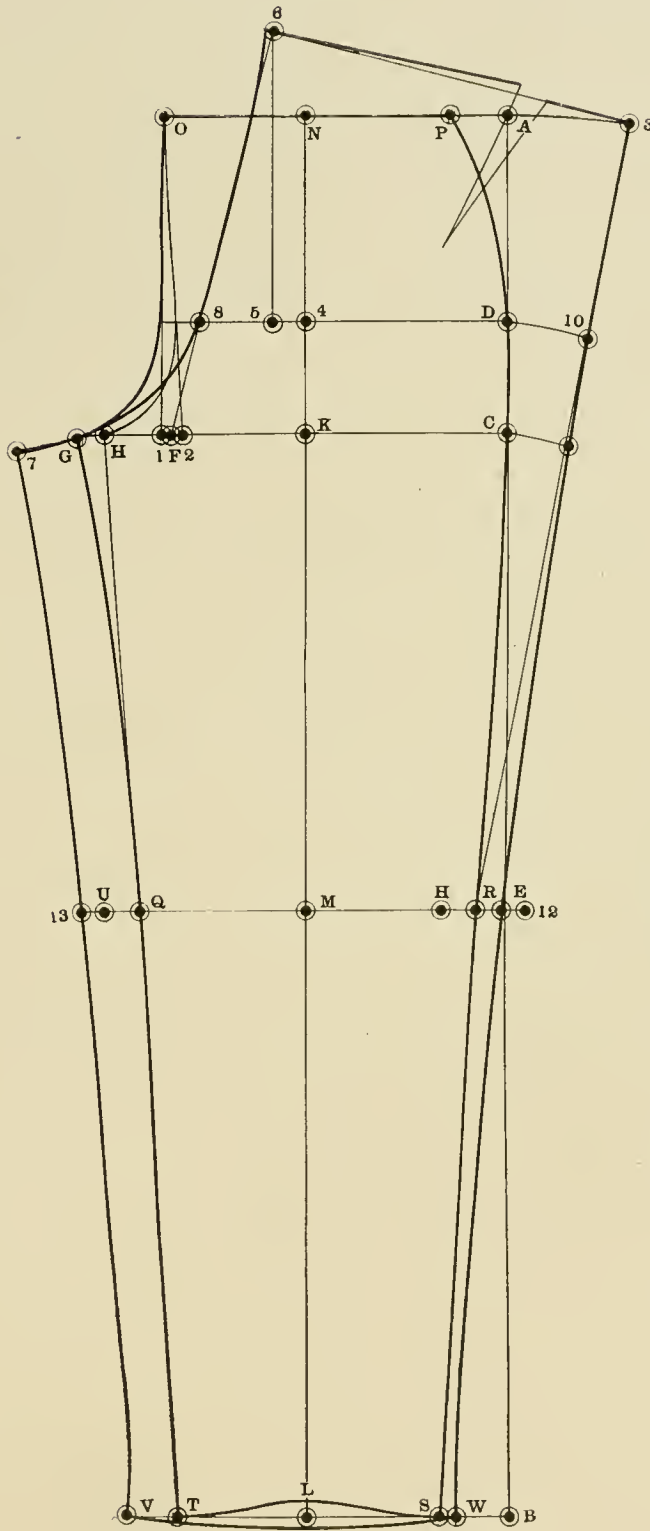

DIAGRAM 149

## DIAGRAMS 150 &amp; 151

This diagram shows how to make Spring Bottom Trousers. In these trousers the knee measure is shown to be 18 inches and the bottom  $19\frac{1}{2}$  inches; make the front part from T to S about 2 inches smaller in size than the knee measure, *i. e.*, the knee measure is 18 inches, therefore make the distance from S to T, 8 inches, which is  $\frac{1}{2}$  of 16.

## THE BACKPART

From Q to U is 1 inch; T to V is  $1\frac{1}{2}$  inches; S to W is  $\frac{1}{2}$  inch; measure the bottom, plus 1 inch for seams from T to S and V to 3; point 4 is halfway between 3 and W; V to 5 is the same distance as 3 to 4; V to 1 is 5 inches; W to 2 is the same; shape the backpart as shown.

**Diagram 151**—This diagram shows how to manipulate the backpart of a pair of trousers for a back bow. After the forepart and backpart have been cut out, proceed as follows: split the backpart as from 1 to 2; overlap the backpart as from 2 to 3,  $\frac{1}{2}$  or  $\frac{3}{4}$  inch; now make the distance from the inseam notch up to 5 the same distance as it was before being split and re-shape the backpart as shown by the broken line. There are quite a number of cutters who claim that in a back bow the forepart should be made longer and the backpart shorter, but as a matter of fact, the forepart is made longer because as the backpart becomes shorter the front part is in itself comparatively longer.



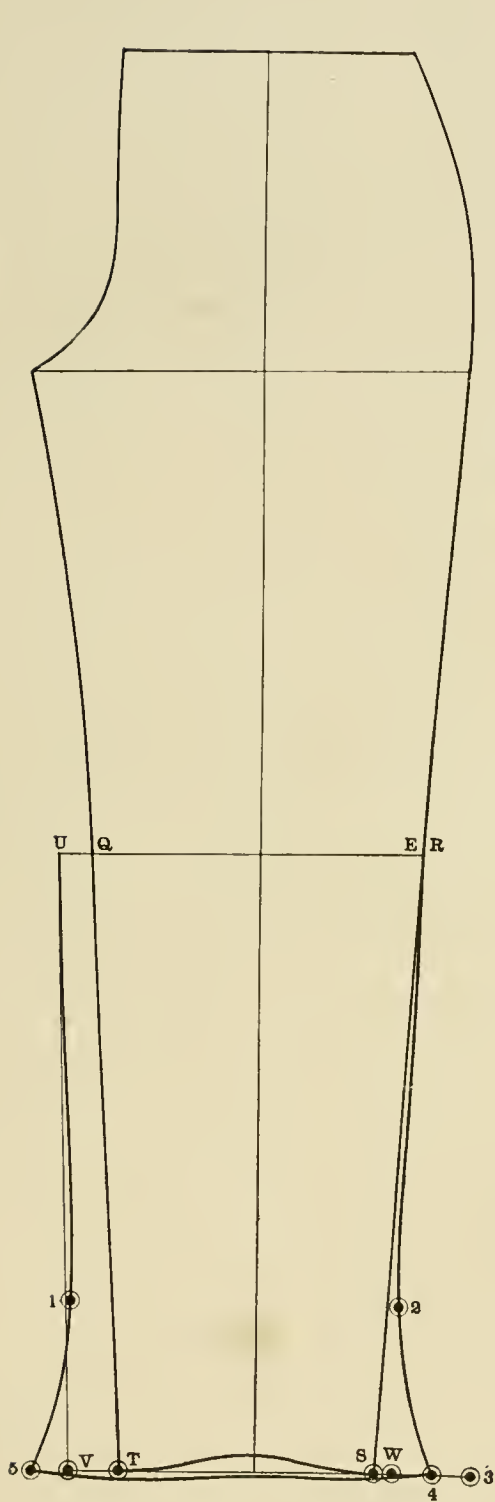

DIAGRAM 150

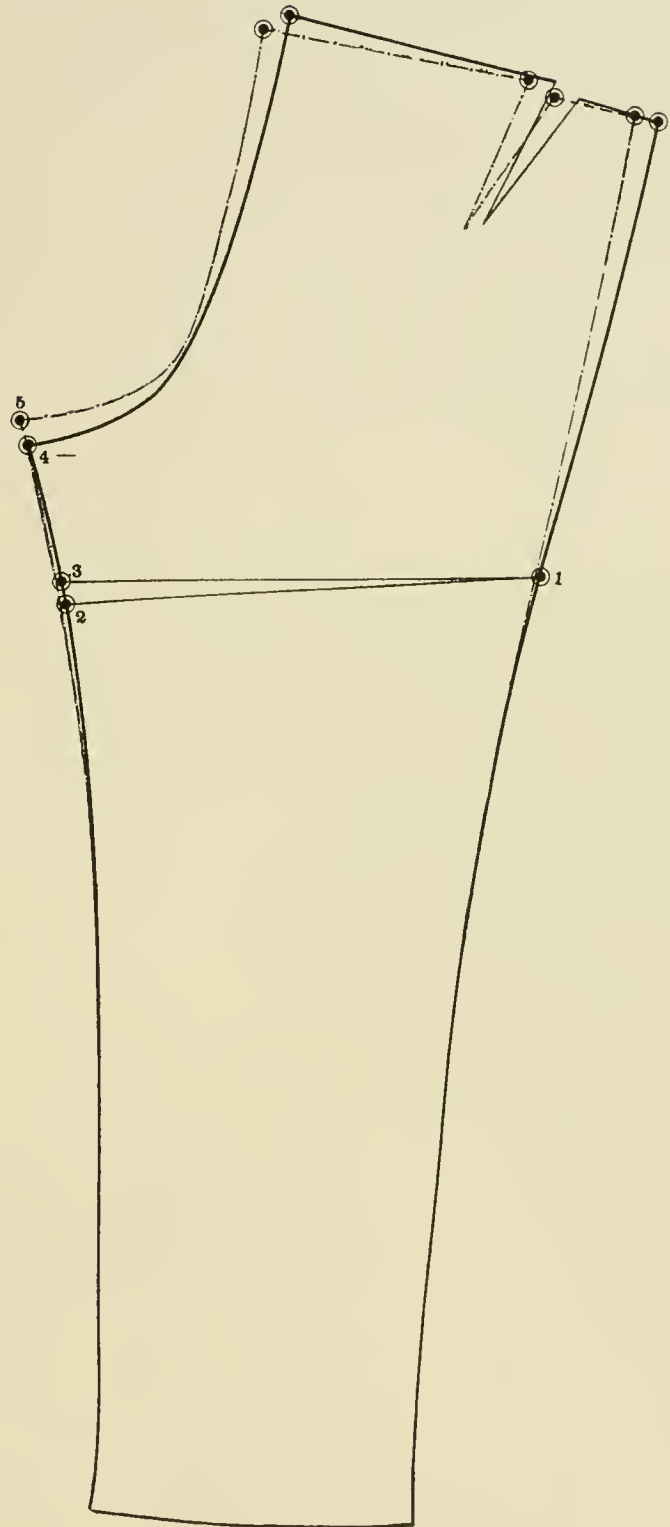

DIAGRAM 151

## DIAGRAMS 152 &amp; 153

## BROAD FALLS

The facing for broad falls is cut as follows: After the side pockets are marked and notched on the forepart, mark C to D, 1 inch; F to H is  $2\frac{1}{2}$  inches; H to J is  $\frac{3}{4}$  inch; F to G is the same; shape the facing as indicated.

## NARROW FALLS

The narrow falls are cut as follows: Line D-F is the center of forepart; from D to F is the same as A to C; square back from F; from F to E is 2 inches; draw a line from D to E; D to G is  $2\frac{1}{2}$  inches; H to K is the same; draw a line from G through K; from K to L is  $\frac{3}{4}$  inch; H to J is the same; draw a line from J to L; cut in the forepart from D to E and finish as represented.



DIAGRAM 152



DIAGRAM 153

## DIAGRAMS 154 &amp; 155

Trousers for bow-legged men are cut as follows:

Ascertain the amount the legs are bowed by having your customer stand with his heels close together; find as nearly as you can the amount of space there is between the knees. Let us say the space is three inches, which means that each leg is bowed  $1\frac{1}{2}$  inches. Now, having cut the forepart in the regular way, proceed as follows: (diagram 151).

Line A-C is the knee line; cut the forepart open as from A to C; lengthen the outside seam by opening the pattern  $\frac{3}{4}$  inch, which is one-half the amount of the bow. Reshape the outside and inseam by filling in slightly at C and reducing the same amount at A-B.

After the forepart is finished as explained, cut the backpart according to the forepart (see diagram 155).

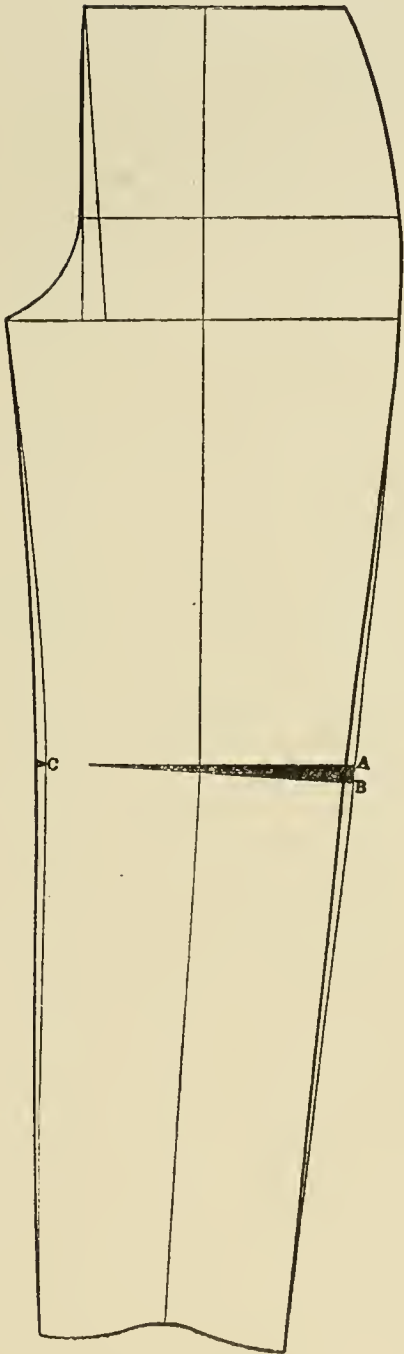

DIAGRAM 151

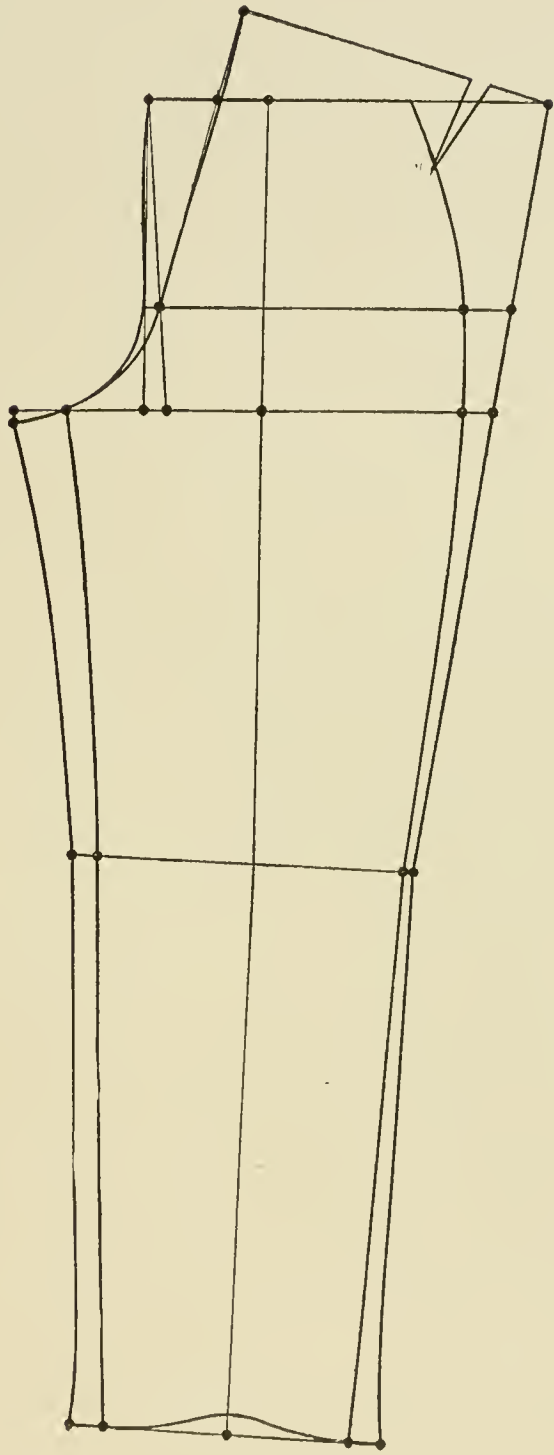

DIAGRAM 155

## DIAGRAM 156

### RIDING BREECHES

Riding breeches are to be measured in the following manner: First take the outside seam length, from the hip bone down to the top of the heel in the regular way, then the inseam in the regular way, next take the waist and seat measures in the usual way for trousers.

After the measurements are taken in this manner, proceed as follows: (see sketch)—The measurements should be taken over the drawers, but if so desired, the trousers may be pinned up close to the leg so as to get the complete outline of the leg; now make a mark as shown on the sketch at 1, which is the regular knee; 2 is the small of the knee; 3 is the largest part of the calf; if an extension is desired, make a mark also at 4.

Now let us suppose that the measurements are as follows.

Outside length .....	42 inches
Inseam .....	32½ inches
(This leaves a rise of 9½ inches.)	
Waist .....	33 inches
Seat .....	39 inches
Length from the crotch to knee .....	13 inches
To the small of the knee .....	16 inches
To the largest part of calf .....	19½ inches

The distance from 3 to 4 is the extension and may be made according to your own judgment.

Around the knee at 1 .....	15 inches
Around the small of knee as at 2 .....	13½ inches
Around the largest part of calf as at 3 .....	14¼ inches
Around as at 4 .....	11 inches

Now proceed with diagram.

Square down and out from A.

From A to C is the rise, in this case 9½ inches; C to D is 2 inches always; this is to give enough length over the knee while sitting; from D to E is 13 inches; to F is 16 inches; to B is 19½ inches; to G let us say 24 inches; square out from C, E, F, B and G.

From C to H is ½ seat; H to 10 is ⅙ seat; point K is halfway between C and 10; square up from H; this locates W; go down from W to X, ½ inch and draw a line from X to Y; from X to Y is ½ waist; from H to I is ½ inch; 10 to J is the same; from B to L is ¼ seat; draw a line from L through K up; this locates points O and M; from M to N is ¼ knee; O to P is ¼ small of knee; from L to Q is ¼ calf. If the extension is desired, extend that line down and make the distance from 17 to U, ¼ ankle.

From L to T is 1 inch; M to R is 1½ inches; draw a line from R through T down; draw a straight line from J through N and shape the crotch and inseam; from Y to Z is the waist band; from C to I is 1¼ inches; draw a line from I to R; shape the outside seam as shown.

### THE BACKPART

Extend all the lines as shown and proceed as follows: from 8 to 9 is ⅙ seat; draw a line from 10 through 9 up; from 9 to 11 is ⅙ seat; from 11 to 12 is ½ waist plus 1½ inches; from 1 to 5 is 1¾ inches; from 12 to 13 is ½ inch; draw a line from 13 to 11; from 13 to 16 is ½ waist plus 2 inches; 13 to 15 is the same width as Y to Z; sweep from 10 to 7 pivoting at N.

From J to 7 is 1¾ inches; draw a line from 7 to N and from N down through P and Q to U; from U to V and U to 22 is the ankle measure plus 1 inch. If the measurements are taken over the trousers they are to be cut without any addition, but if taken over the drawers, there is to be 1 inch addition. This includes all the measurements, i. e., the calf, the small of the knee and the knee measurements.

From Q to T and Q to 2 is the calf measure; from P to S and P to 3 is the small of knee measure; from N to R and N to 4 is the knee measure; shape the side seam of the backpart from 12 through 5, 1, 3 and 2, extending the line from 2 to 23 so as to give it a regular run. Suppress the distance between 22 and 23 by cutting out a V as between 20 and 21, including two seams for making up same; add from 4 to 24, 1¼ inches; 23 to 25 is the same; this is to be used for a button stand.

If the cloth is soft and can easily be shaped with the iron, the backpart is to be stretched between N and Q, also between 4 and 2, and the front part is to be filled in above the knee. Usually the kind of material riding breeches is made of is hard to press, in which case split the backpart between 3 and 4 and N and P; take out 1½ inch fish under the knee. These two pieces are to be sewn together and this helps to form the backpart of the trousers. The V which is taken out between 20 and 21 is to give the proper round over the calf.

From 18 to 20 and from V to 21 is the same distance as has been taken out between 19 and V and 19 and 18. When this V is sewn up, it will require this much more length in order to give the bottom of the breeches a straight run.

Cut out a ½ inch V at the top of the waistband and finish.

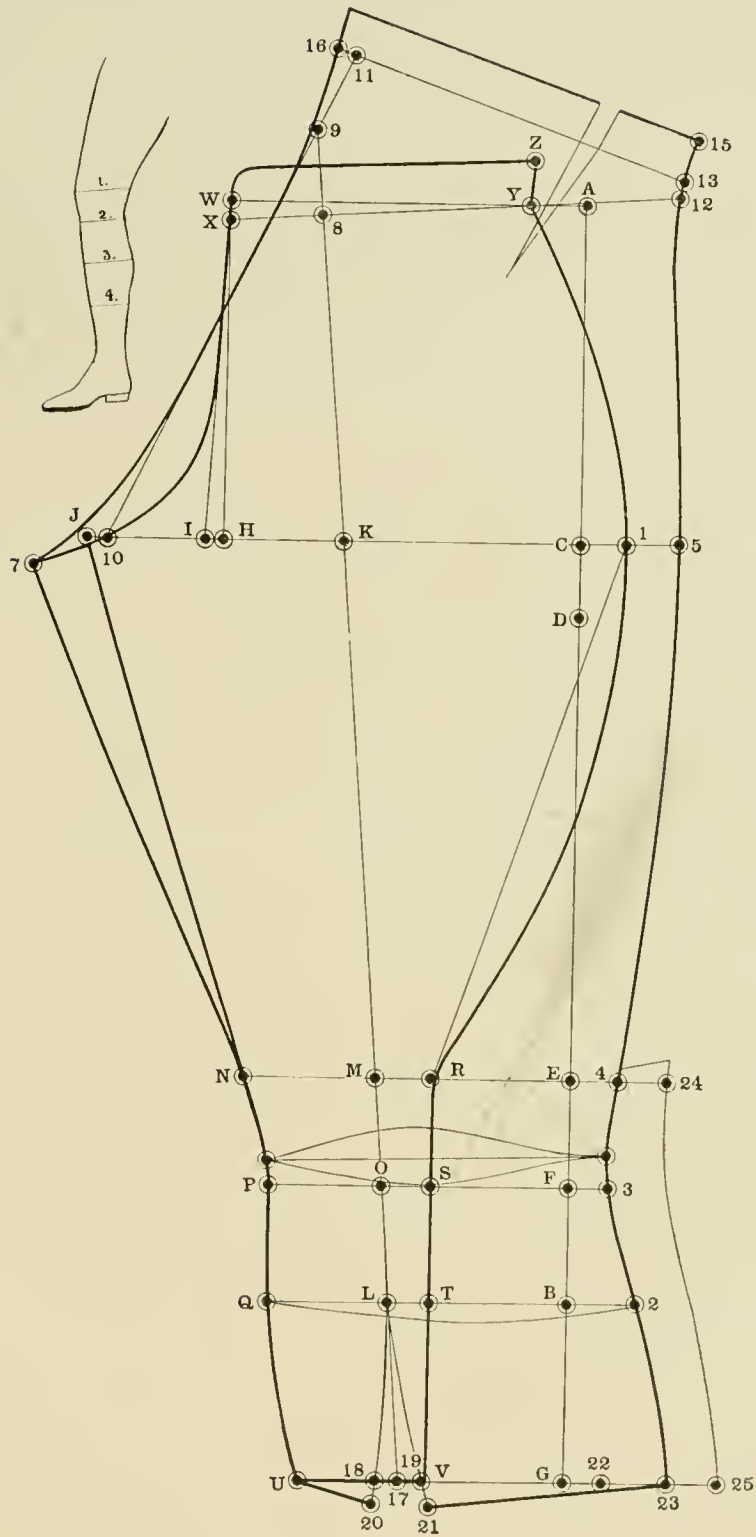

DIAGRAM 156

## DIAGRAM 157

Riding breeches without extensions. These breeches are made the same as shown on diagram 156, except that they are made without the extensions, and the material is such as can be shaped with the iron, therefore, there is no fish cut out under the knee and the backpart is cut one-half inch shorter than the forepart so as to allow for the stretching under the knee.



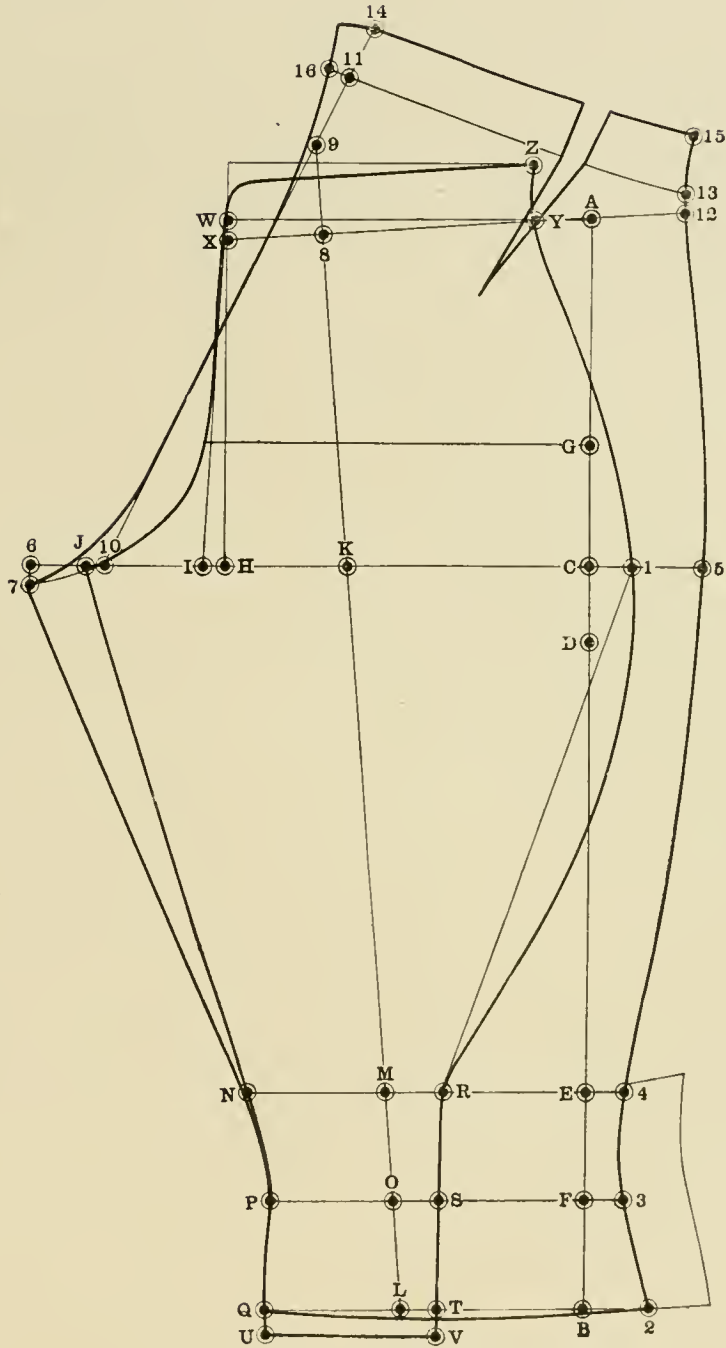

DIAGRAM 157

## DIAGRAM 158

## COACHMAN'S BREECHES

The measurements are as follows:

Outside length .....	43 inches	Knee .....	15 inches
Inseam .....	33 inches	Small of knee .....	13 inches
Waist .....	33 inches	Calf .....	14 inches
Seat .....	39 inches		

Draw line A-B and square out to P.

From A to C is the difference between the outside and inside seams, 10 inches; from C to E is 1 inch less than  $\frac{1}{2}$  of the inseam,  $15\frac{1}{2}$  inches; E to I is 3 inches; from I to B is 4 inches; C to D is  $\frac{1}{6}$  seat; square out from C, D, E, I and B.

From C to H is  $\frac{1}{2}$  seat; from H to J is  $\frac{3}{4}$  inch; square up from J to get P; draw a line from H to P to get 23; from J to L is  $\frac{1}{8}$  seat; L back to K is  $\frac{5}{8}$  inch; point 12 is half-way between C and K; from B to 11 is the same distance as C to 12; draw a line from 11 through 12 to locate points 26, 25 and O.

From 11 to T is  $\frac{1}{4}$  of the calf; from 26 to S is  $\frac{1}{4}$  of the small of knee; 25 to R is  $\frac{1}{4}$  of the knee measure; from 11 to 13 is 1 inch less than 11 to T; from 26 to 21 is 1 inch less than 26 to S; from 25 to 24 is 1 inch less than 25 to R.

From O to P is  $\frac{1}{4}$  waist; O to M is the same; shape the forepart as indicated.

## THE BACKPART

Extend lines 12-O, P-M, 23-D, C-L, R-24, S-21 and T-13.

From T to 13 and T to 16 is the calf measure plus 1 inch for seams; from S to 21 and S to G is the small of knee measure plus 1 inch; from R to 24 and R to F is the knee measure plus 1 inch; from D to 22 is 2 inches; O to 2 is  $\frac{1}{2}$  waist; O to 4 is  $\frac{1}{6}$  seat; draw a line from 2 through 4; 2 to 5 is  $\frac{1}{2}$  waist plus 1 inch; draw a line from 5 to 23; L to 6 is  $\frac{1}{2}$  seat; 6 to 7 is  $\frac{3}{8}$  inch; shape the backpart and finish as indicated.

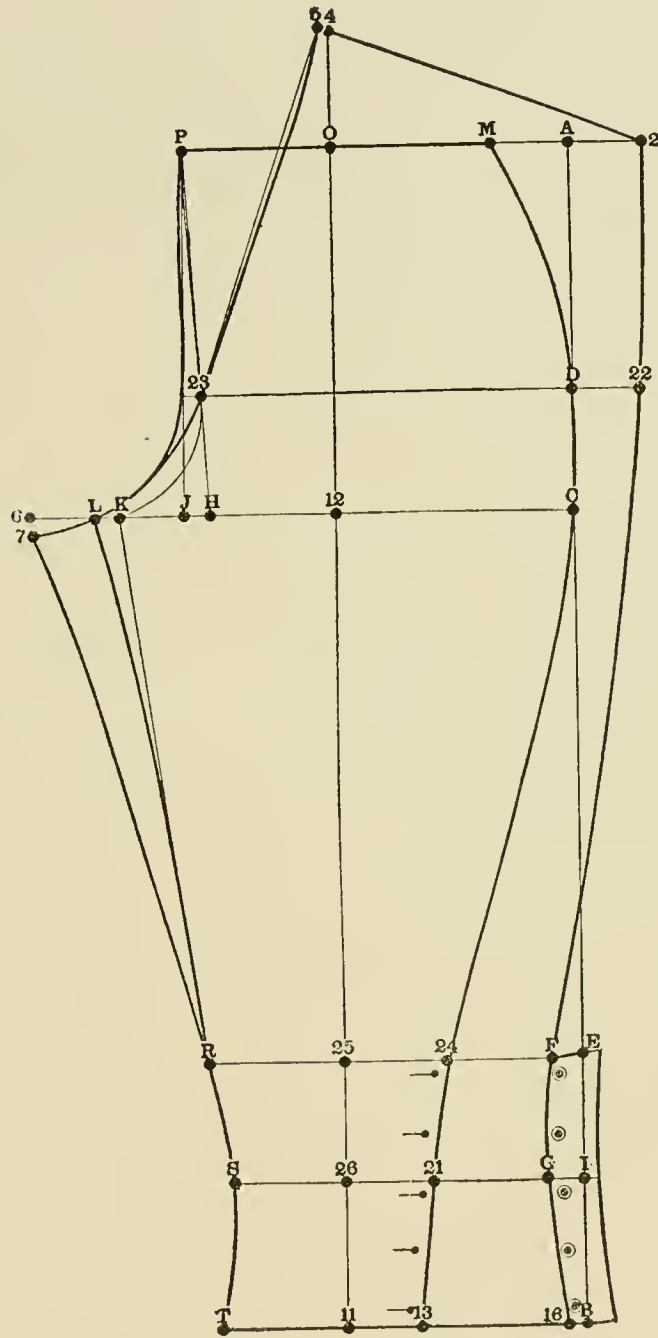

DIAGRAM 158

## DIAGRAM 159

## KNICKERBOCKERS

The measurements are as follows:

Outside seam .....	42 inches	Seat .....	40 inches
Inseam .....	32 inches	Small of knee .....	13 inches
Waist .....	34 inches	Calf .....	14 inches

Draw line A-C and square out to S.

From A to D is the difference between the inside seam and the outside seam, which is 10 inches; from D to 13 is 1 inch less than  $\frac{1}{2}$  of the inseam, which is 15 inches; from 13 to B is  $2\frac{1}{2}$  inches, and from B to C is 4 inches; from D to E is  $\frac{1}{8}$  seat; square out from E, D, 13, B and C.

From D to G is  $\frac{1}{2}$  seat; G to H is  $\frac{3}{4}$  inch; square up from 11 to get point S; draw a line from G to S to get point 3; J is halfway between G and 11; J to K is  $\frac{1}{8}$  seat; K to L is  $\frac{1}{2}$  inch; M is halfway between D and K; from C to N is the same distance as from D to M; from 11 to U is  $\frac{1}{4}$  of the small of knee; 11 to 13 is the same; from N to 7 is  $\frac{1}{4}$  of the calf; N to 9 is the same; from 9 to 14 is 1 inch; 13 to 12 is the same; draw a line from 12 to 11; D to Z is  $1\frac{1}{4}$  inches; from R to S is  $\frac{1}{4}$  waist; R to T is the same; shape the forepart as indicated.

## THE BACKPART

Extend lines A-S, Z-L, V-U and 14-7; from 7 to 8 is  $\frac{1}{2}$  inch; U to W is the same; from L to X is  $\frac{1}{8}$  seat; X to Y is  $\frac{3}{8}$  inch; from Z to 15 is  $1\frac{1}{2}$  inches; from R to 16 is  $\frac{1}{2}$  waist; R to 5 is  $\frac{1}{8}$  seat; from 15 to 4 is the same length as Z to T; draw a line from 16 through 5; from 4 to 6 is  $\frac{1}{2}$  waist plus 1 inch; draw a line from 6 to 3.

Apply the small of knee measure plus 1 inch for seams from 12 to U and W to V, which is 11 inches; apply the calf measure plus 1 inch for seams from 7 to 14 and from 8 to 10 which is 15 inches; shape the backpart as indicated.

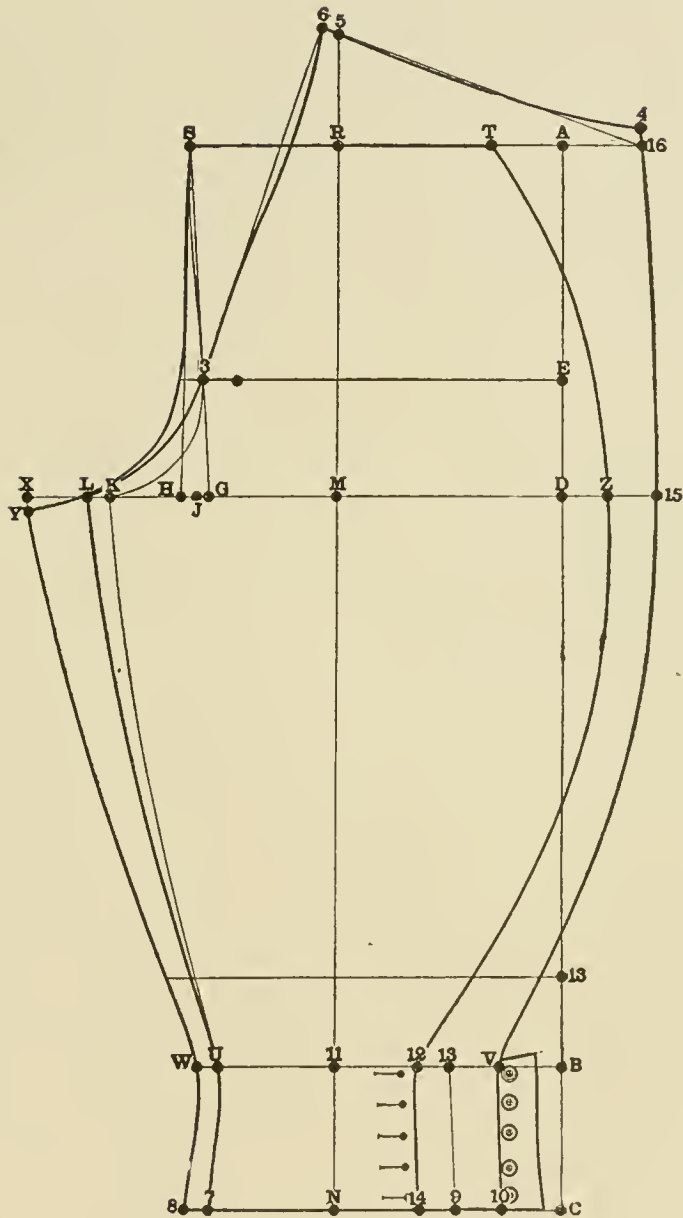

DIAGRAM 159

## DIAGRAM 160

## GOLFING BREECHES

The measurements are as follows:

Outside length to knee . . . . .	23½ inches	Seat . . . . .	40 inches
Full length . . . . .	42 inches	Knee . . . . .	22 inches
Inseam . . . . .	32 inches	Small of the knee . . . . .	13 inches
Waist . . . . .	34 inches		

Draw line A-C and square out to S.

From A to D is the difference between the outside and inside lengths which is 10 inches; to B is the knee length, 23½ inches; from B to C is 6 inches; D to E is ½ seat; square out from E, D, B and C.

From D to G is ½ seat; G to H is ¾ inch; square up from H to get S; draw a line from G to S to get 3; point J is halfway between G and H; from J to K is ⅛ seat; K to L is ½ inch; point M is halfway between D and K; from C to N is the same distance as D to M; draw a line from N through M; this locates Q-R; from N to O is ½ inch; from N to P is the same; cut out a V between P and O reaching up to Q; from P to 7 is ¼ of the small of knee plus ¼ inch; O to 9 is the same; from Q to V is ¼ knee; Q to U is the same; from R to S is ¼ waist; R to T is the same; from D to Z is 1¼ inches; shape the forepart as indicated.

## THE BACKPART

Extend lines S-T, 3-E, L-Z, U-V and 7-9. From R to 4 is ½ waist; R to 5 is ⅓ seat; draw a line from 4 through 5; 4 to 6 is ½ waist plus 1 inch; draw a line from 6 to 3; from 3 to F and 3 to 2 is the seat measure plus 3¼ inches; from L to X is ⅓ seat; X to Y is 3⁄8 inch; U to W is ½ inch; V to B is the same; 7 to 8 is ½ inch; 9 to 10 is the same; take out a V from the back the same as between P and O on the forepart; shape the backpart as indicated and finish.

The cuff on the bottom is to be about 3 inches wide.

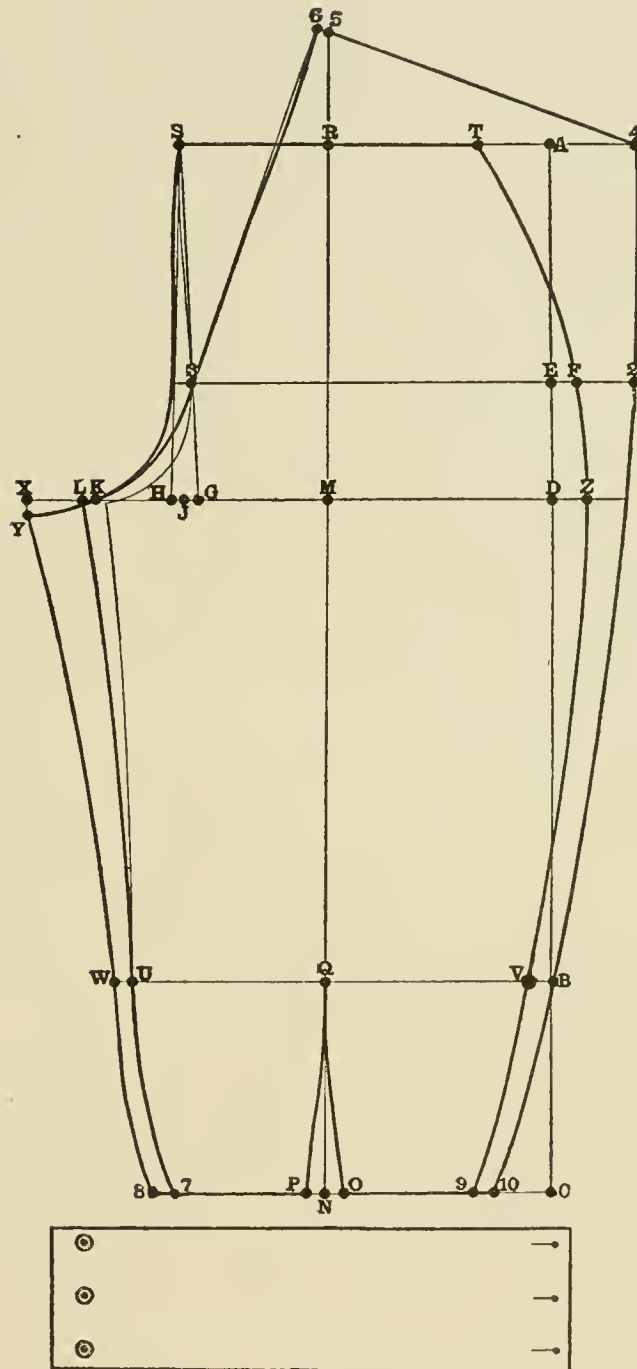

DIAGRAM 160

## DIAGRAM 161

## STRAIGHT-FRONT SACK FOR A BOY 6 YEARS OF AGE

The Proportion Table comes as near the actual breast and waist sizes for children as it does for grown people, but in cutting children's clothing it is always advisable to cut same two sizes larger, as it is not good judgment to have children's clothing fit as closely as men's garments. This coat, therefore, is increased two sizes.

The measurements for this coat are as follows:

Breast .....	26	inches
Waist .....	25	inches
Seat .....	28½	inches
Waist length.....	12¾	inches
Sleeve (taken from the center of the back to the elbow and the full length to the wrist .....	21½	inches

Around wrist 9½ inches (see proportion table for boys and youths.)

Square down and out from A.

From A to B is ¼ breast; C is waist length; C to D is 5 inches; E is full length; F is halfway between A and B; G is halfway between A and F; square out from G, B, C, D and E.

From C to 2 is ½ inch; E to 22 is ¼ inch; shape the center of back from F to 2 and down to 22; from 1 to H is ½ breast; H to I is 1¼ inches; I to J is ¾ inch; from 1 to L is ¾ breast on square division plus ½ inch; square up and down from L; this locates Q; M is halfway between 1 and L; M to N is 1 inch; square up from N to locate O.

From A to 8 is 6¾ inches; 8 to 9 is 1½ inches; draw a line from A to 9; A to 10 is ¼ breast; this may be made ⅓ breast plus ¼ inch if so desired; square up from 10 to locate 11; draw a line from 11 to O; N back to 4 is ¼ inch; from 22 to 7 is the same distance as from 1 to N; draw a line from 7 to 4; N to P is ½ breast; shape the back.

From Q to S is ½ waist; point T is halfway between Q and S; point U is halfway between L and 1; draw a line from T through U up; from A to 11 and L to V is ⅓ breast plus ¾ inch; draw a line from V to O; from V to Z is ¼ inch less than 11 to O; shape the shoulder and armscye as shown.

Square forwards from V by line T-U; from V to W is ⅓ breast plus ¼ inch; draw a rounding line from W to J; J to 12 is 1 inch; S to 13 is the same; shape the front edge through 12 and 13 down; from S back to 14 is the same distance as from J to H; from 6 to 15 is the same distance as from 13 to 14; from 19 to 3 and 15 to 20 is the seat measure; shape the side seam. From 5 to 21 is the same distance as from 5 to 7; from 16 to 17 is ⅓ breast; shape the front edge, bottom of forepart and finish.

## THE COLLAR

From V to 23 is ¾ inch; draw a line for the lapel break through 23; from 23 to 24 is ¼ inch more than A to 11 on the backpart; 24 to 25 is ½ inch; 25 to 26 is ¾ inch; shape the collar as shown and finish.



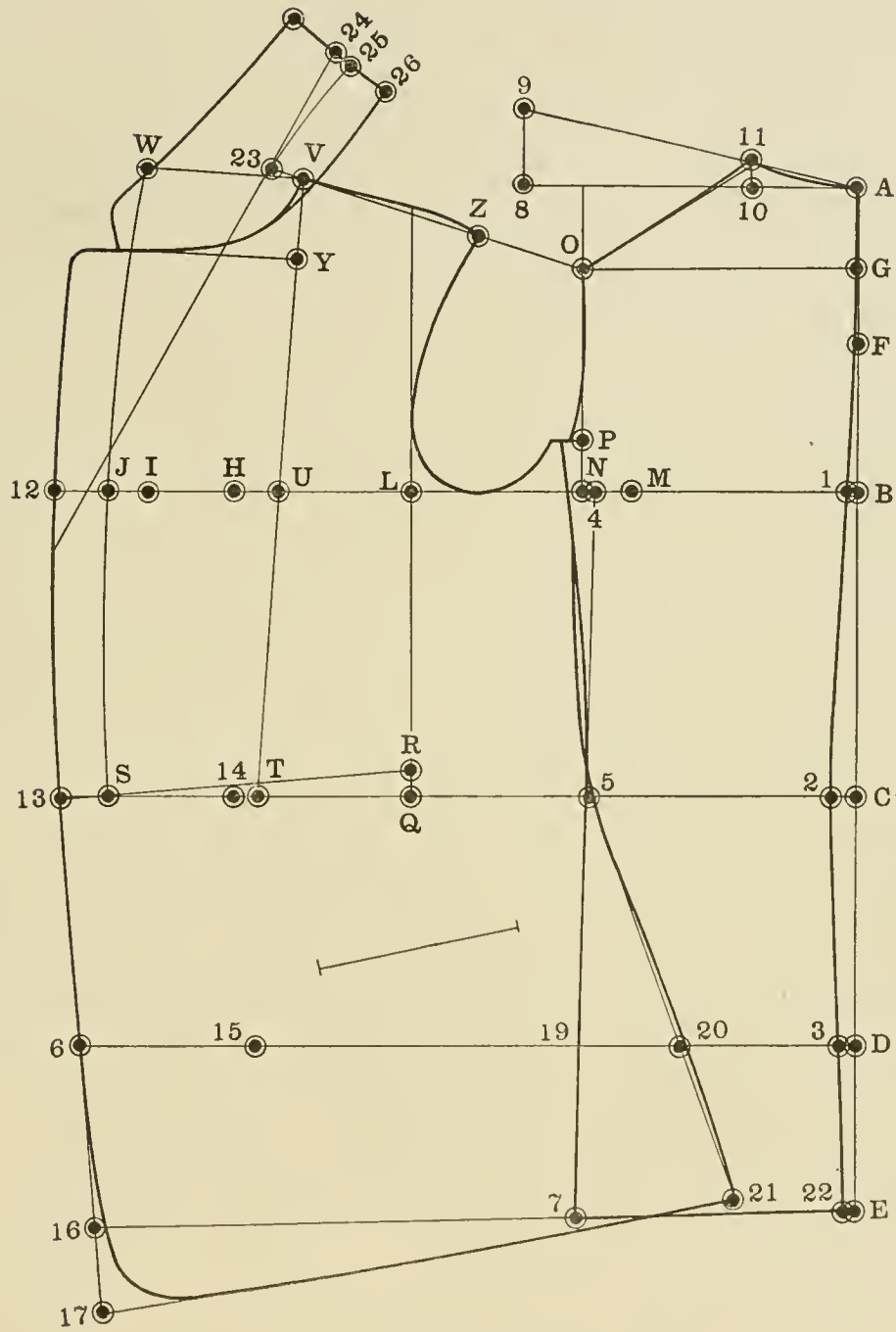

DIAGRAM 161

## DIAGRAM 162

DOUBLE-BREASTED SACK FOR A BOY, 12 YEARS (*Increased 2 sizes*)

The measurements are as follows:

Breast .....	30½ inches	Coat length .....	24½ inches
Waist .....	28 inches	Sleeve length .....	27 inches
Hip .....	32½ inches	Wrist .....	11 inches
Waist length .....	14⅔ inches		

Square down and out from A.

From A to B is  $\frac{1}{4}$  breast; C is waist length; C to D is 5 inches; A to E is full length; F is halfway between A and B; G is halfway between A and F; square out from G, B, C, D and E.

From C to 2 is  $\frac{1}{2}$  inch; E to 22 is  $\frac{1}{2}$  the distance of C to 2; draw a line from F to 2 and down; from 1 to H is  $\frac{1}{2}$  breast; H to I is  $1\frac{3}{4}$  inches; I to J is  $\frac{3}{4}$  inch; from 1 to L is  $\frac{3}{8}$  breast (on square division) plus  $\frac{1}{2}$  inch; square up and down from L; M is halfway between I and L; M to N is 1 inch; square up from N; from N to P is  $\frac{1}{2}$  breast; N back to 4 is  $\frac{1}{4}$  inch; from 22 to 7 is the same distance as from 1 to 4; draw a line from 4 to 7; from A to 8 is  $6\frac{3}{8}$  inches; 8 to 9 is  $1\frac{1}{2}$  inches; draw a line from A to 9.

From A to 10 is  $\frac{1}{8}$  breast; square up from 10 to locate 11; draw a line from 11 to O and shape the back; from Q to S is  $\frac{1}{2}$  waist; point T is halfway between Q and S; point U is halfway between L and I; draw a line from T through U up; from A to 11 and L to V is  $\frac{1}{8}$  breast plus  $\frac{3}{4}$  inch; draw a line from V to O; from V to Z is  $\frac{3}{8}$  inch less than 11 to O; shape the shoulder and armseye.

Square forwards from V by line T-U; from V to W is  $\frac{1}{8}$  breast plus  $\frac{1}{2}$  inch; draw a rounding line from W to J; from W to X is  $\frac{1}{8}$  breast; V to Y is  $\frac{1}{8}$  breast; draw a line from Y to X and shape the gorge; from J to 12 is  $2\frac{1}{2}$  inches; S to 13 is the same; from Q to R is  $\frac{1}{2}$  inch; square down from 13 by line R-13; this locates points 6 and 16; from 16 to 17 is  $\frac{1}{8}$  breast; from 6 back to 15 is the same distance as from H to 12; from 23 to 3 and 15 to 20 is the seat measure; 20 back to 19 is 2 inches; square up from 19 to locate 18; draw a line from 18 through 20 down and shape the side of forepart; from 18 to 21 is the same distance as from 5 to 7; shape the bottom of forepart and finish.

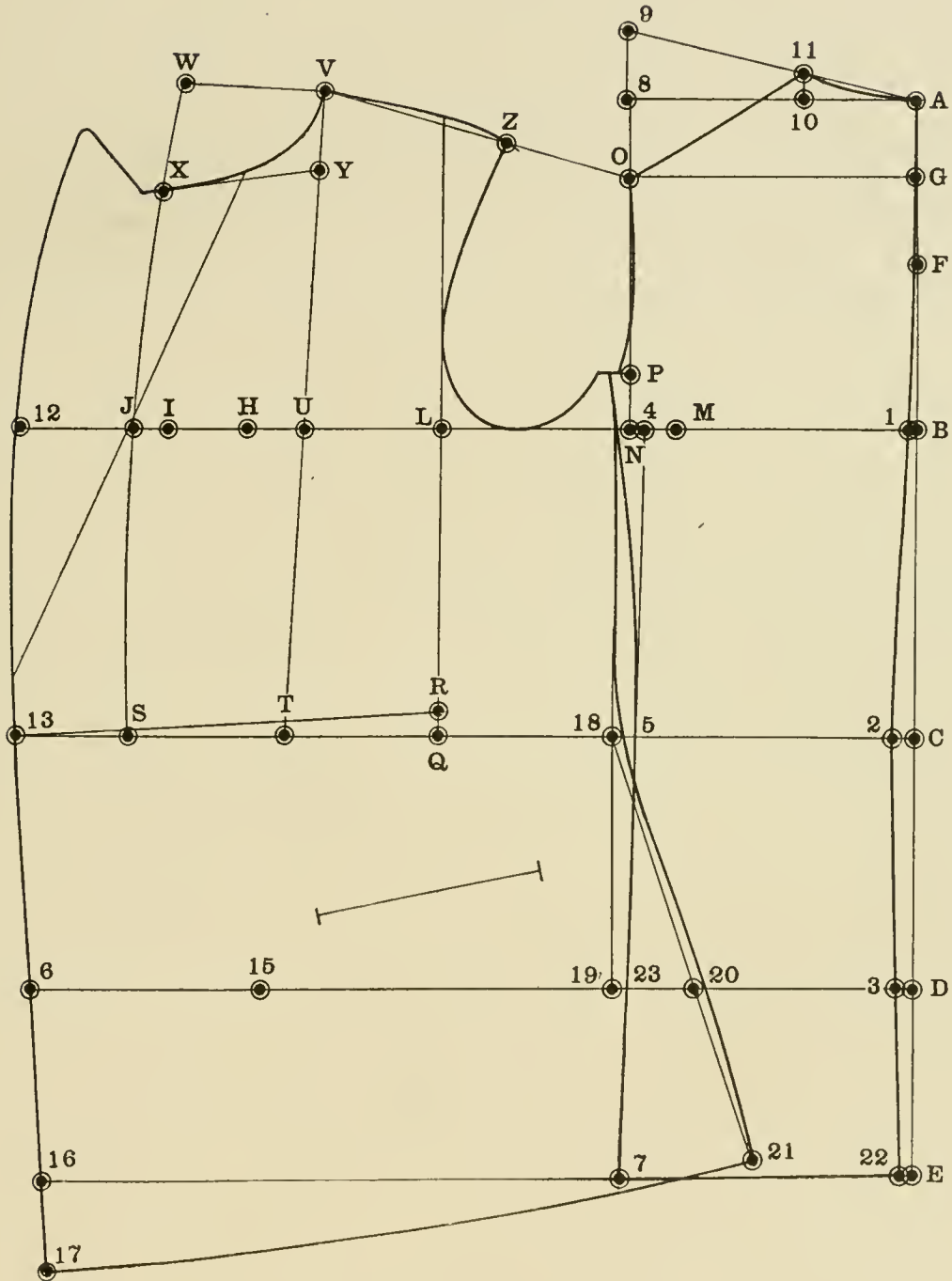

DIAGRAM 162

## DIAGRAM 163

## SINGLE-BREASTED OVERCOAT FOR A BOY, 10 YEARS

For further measurements see Proportion Table: (increase these overcoats 2 sizes the same as for other coats.)

Breast .....	29 inches
Waist .....	27 inches
Seat .....	31 inches

Square down and out from A.

From A to B is  $\frac{1}{4}$  breast; B to 1 is  $\frac{3}{4}$  inch; A to C is waist length plus  $\frac{1}{2}$  inch; C to D is 5 inches; E is full length; F is halfway between A and 1; G is halfway between A and F; square out from G, B, 1, C, D and E.

From C to 2 is  $\frac{1}{2}$  inch; E to 22 is the same; draw a line from F to 2 and 2 to 22; B to 24 is  $1\frac{1}{2}$  inches; 24 to H is  $\frac{1}{2}$  breast; H to I is  $1\frac{3}{4}$  inches; I to J is  $\frac{3}{4}$  inch; from 24 to L is  $\frac{2}{3}$  (on square division) breast plus  $\frac{1}{2}$  inch; square up and down from L; J back to K is  $\frac{1}{2}$  inch; square up from K; M is halfway between B and K; M to N is 1 inch; square up from N; from N to P is 1 inch; N back to 4 is  $\frac{1}{4}$  inch; 22 to 7 is the same distance as from B to N; draw a line from 4 to 7.

From A to 8 is  $6\frac{3}{8}$  inches; 8 to 9 is  $1\frac{1}{2}$  inches; draw a line from A to 9; A to 10 is  $\frac{1}{8}$  breast; square up from 10 to locate 11; draw a line from 11 to O and shape the back; Q to S is  $\frac{1}{2}$  waist; point T is halfway between Q and S; point U is halfway between L and I; draw a line from T through U up; from A to 11 and L to V is  $\frac{1}{8}$  breast plus  $\frac{3}{4}$  inch.

Draw a line from V to O; from V to Z is  $\frac{1}{4}$  inch less than 11 to O; shape the shoulder and armseye; square forwards from V by line T-U; from V to W is  $\frac{1}{8}$  breast plus  $\frac{1}{4}$  inch; draw a rounding line from W to J; V to Y is  $\frac{1}{8}$  breast; square forwards from Y and shape the gorge.

From J to 12 is  $1\frac{1}{2}$  inches; S to 13 is the same; Q to R is  $\frac{1}{2}$  inch; square down from 13 by line R-S; this locates points 6 and 16; 16 to 17 is  $\frac{1}{8}$  breast; 6 back to 15 is the same distance as from H to 12; from 23 to X and 15 to 20 is the seat measure; 20 back to 19 is 2 inches; square up from 19 to locate 18; draw a line from 18 through 20 down and shape the side of forepart; from 18 to 21 is the same distance as from 18 to 7; shape the bottom of forepart and finish.

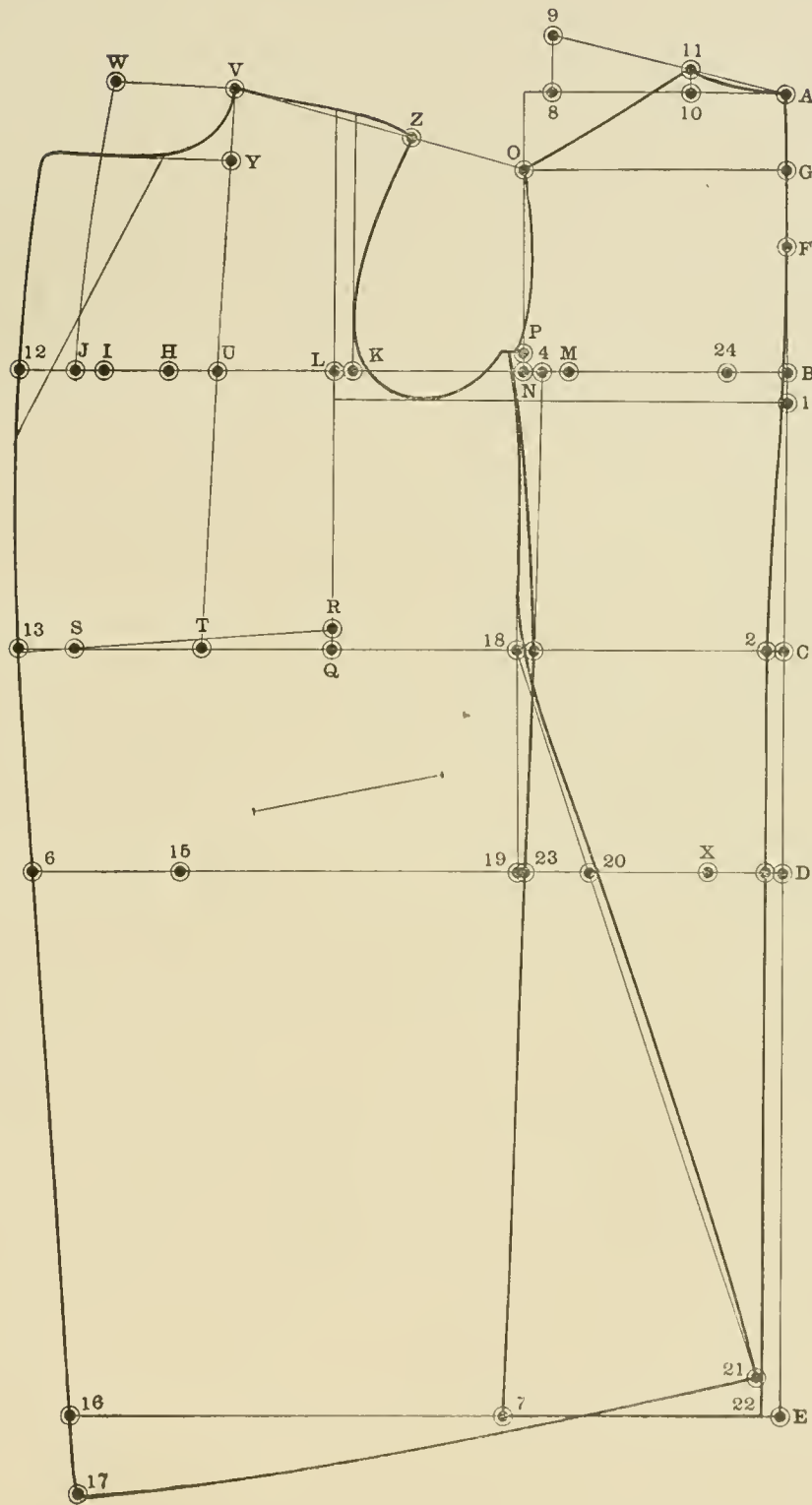

DIAGRAM 163

## DIAGRAM 164

## DOUBLE-BREASTED BOX OVERCOAT FOR A BOY, 16 YEARS

For further measurements see Proportion Table.

Breast .....	32	inches
Waist .....	29	inches
Seat .....	33 $\frac{3}{4}$	inches

Square down and out from A.

From A to B is  $\frac{3}{4}$  breast; B to 1 is 1 inch; A to C is waist length plus  $\frac{1}{2}$  inch; D is full length; F is halfway between A and 1; G is halfway between A and F; square out from G, B, 1, C and D.

From C to 2 is  $\frac{1}{2}$  inch; draw a line from F through 2 down; this locates 22; square forwards from 22; from B to 21 is  $1\frac{1}{2}$  inches; 21 to H is  $\frac{1}{2}$  breast; H to I is  $1\frac{1}{2}$  inches; I to J is  $\frac{3}{4}$  inch; from 21 to L is  $\frac{2}{3}$  breast (on square division) plus  $\frac{1}{2}$  inch; square up and down from L; L back to 18 is  $\frac{1}{2}$  inch; square up and down from 18; M is halfway between B and 18; M to N is 1 inch; square up from N to locate O.

From A to 8 is  $6\frac{3}{8}$  inches; 8 to 9 is  $1\frac{1}{2}$  inches; draw a line from A to 9; A to 10 is  $\frac{1}{6}$  breast; square up from 10 to locate 11; draw a line from 11 to O and shape the back; point 3 is where the armhole crosses the breast line; square down from 3 to locate 4; 4 to 5 is  $1\frac{1}{2}$  inches; 5 to 6 is  $3\frac{1}{2}$  inches; draw lines from 3 through 5 to 7 and from 3 through 6 to 15.

From Q to S is  $\frac{1}{2}$  waist; point T is halfway between P and S; point U is halfway between L and I; draw a line from T through U up; A to 11 and L to V is  $\frac{1}{3}$  breast plus  $\frac{3}{4}$  inch; draw a line from V to O; from V to Z is  $\frac{3}{8}$  inch less than 11 to O; shape the shoulder and armseye.

Square forwards from V by line T-U; V to W is  $\frac{1}{6}$  breast plus  $\frac{1}{2}$  inch; draw a rounding line from W to J; W to X is  $\frac{1}{6}$  breast; V to Y is  $\frac{1}{8}$  breast; draw a line from Y through X and shape the gorge. From J to 12 is  $\frac{1}{2}$  buttonstand, in this case  $2\frac{1}{2}$  inches; S to 13 is the same; Q to R is 1 inch; place the square to points R-13 and square down; this locates 16; 16 to 17 is  $\frac{1}{8}$  breast; now add to the backpart from 3 to K, 1 inch and from 7 to 14 the same; from 3 to 15 is the same distance as from K to 14; shape the bottom and finish.

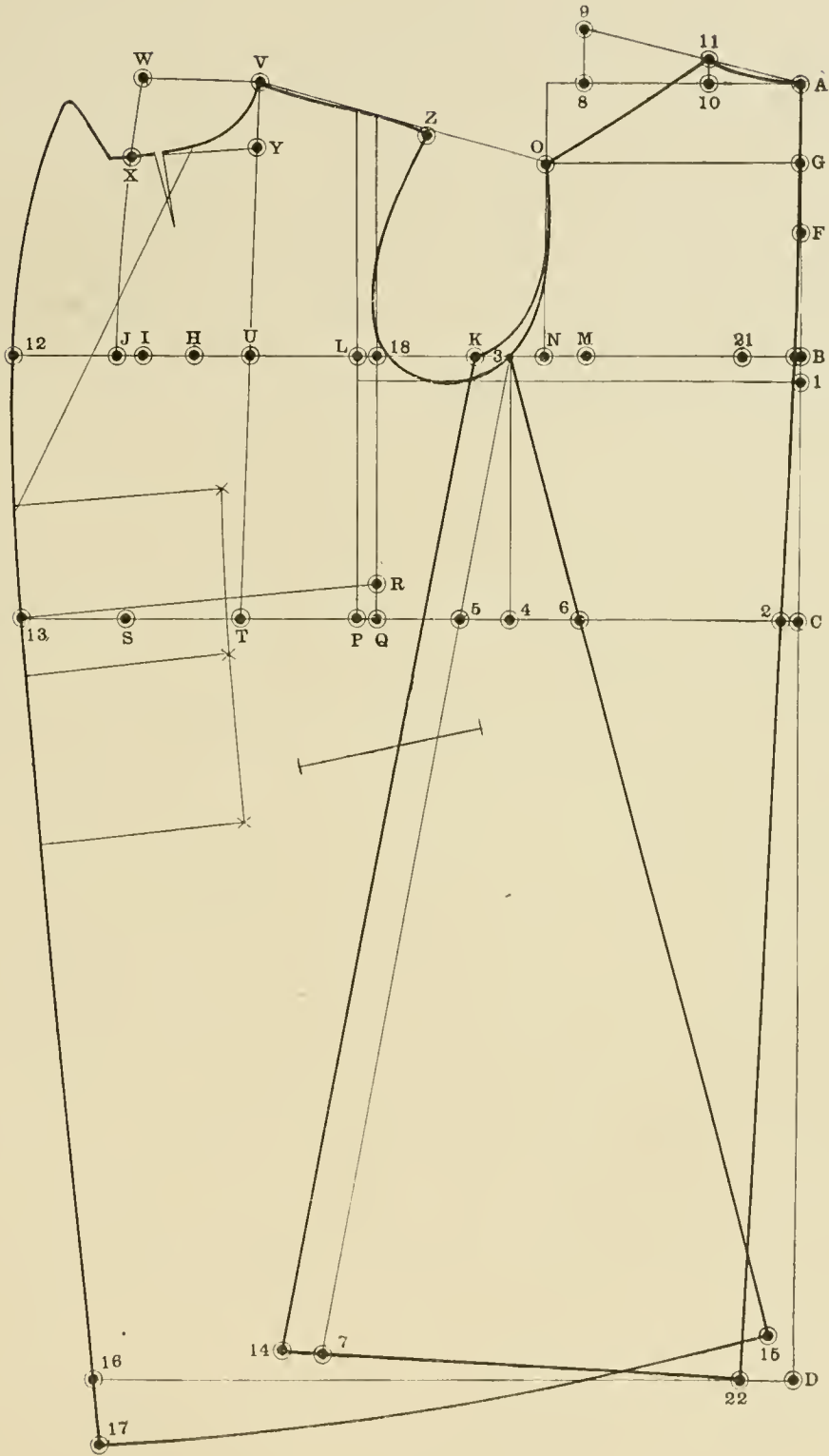

DIAGRAM 164

## DIAGRAM 165

## BOYS' SLEEVE

The sleeve for children's coats is made as follows: measure around the armseye closely and cut the sleeve by the armseye.

Draw line A-F and square back to I.

From A to I is  $\frac{1}{2}$  of the armseye; square down from I; from A to B is  $\frac{1}{2}$  of the armseye; B to D is  $\frac{1}{4}$  of the armseye; D to E is the same; square out from B and D; from D to C is 1 inch; from C to H is  $\frac{1}{2}$  of the armseye; H to J is  $\frac{3}{4}$  inch; draw a line from C to H; point G is halfway between C and H; draw a line from E to J.

From A to K is  $\frac{1}{8}$  of the armseye; K to L is the same; from D to F is the sleeve length; from D to O is 1 inch; D to P is the same; F to Q is 1 inch; F to R is the same; place the square at G-F and square back to N; from F to N is the width of the sleeve desired plus 1 inch for seams; point T is halfway between C and F; square back from T to locate M; from S to T is  $\frac{1}{2}$  inch; U to V is the same; shape the upper and under sleeve as indicated.

## DIAGRAM 166

## BOYS' TROUSERS

Boys' trousers are cut as follows: (for measurements see Table of Proportions for Boys and Youths).

Draw line A-D and square out to I.

From A to C is the rise; C to D is the inseam; C to 2 is  $\frac{1}{8}$  seat; square out from 2, C and D; from C to E is  $\frac{1}{2}$  seat; E to V is  $\frac{1}{8}$  seat; G is halfway between C and V; from D to F is the same distance as C to G; draw a line from F through G to get 7; from F to N is  $\frac{1}{4}$  bottom; F to O is the same; square up from E to get I; from I to K is  $\frac{1}{2}$  waist; shape the forepart as indicated.

## THE BACKPART

Extend lines G-7, I-K, 6-2, C-V and N-O.

From N to Q is  $\frac{1}{2}$  inch; O to R is the same; V to U is  $1\frac{1}{2}$  inches; U to 5 is  $\frac{1}{4}$  inch; 2 to 3 is  $1\frac{1}{2}$  inches; from 7 to X is  $\frac{1}{8}$  seat; draw a line from X to 6; sweep from K to Y pivoting at N; X to V is  $\frac{1}{2}$  waist plus 1 inch; shape the backpart as shown and finish.



DIAGRAM 165

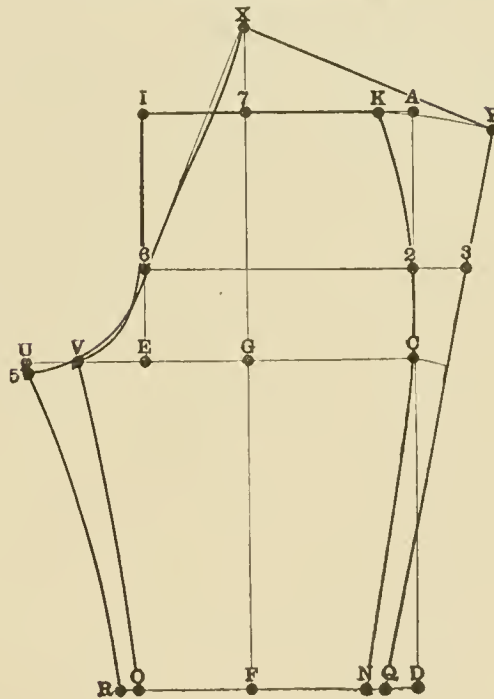
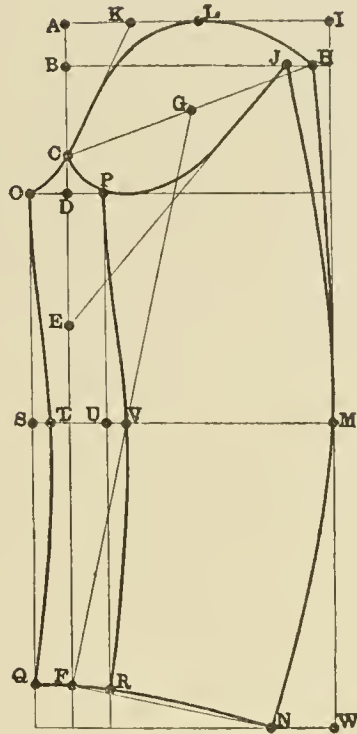

DIAGRAM 166

## DIAGRAM 167

## NORFOLK COAT

Of course there is no limit to the various styles and ways of producing Norfolk Jackets, but no matter what the style may be they must all be made to come up to the original pattern after the various plaits are inserted. The two Norfolk coats shown here are merely offered as suggestions on how to produce same.

This coat is cut from the ordinary sack coat pattern. After the pattern is cut out as usual, proceed as follows:

## THE BACKPART

Point F is halfway between E and G; from E to A is  $1\frac{1}{4}$  inches; G to B is the same; cut the back through as marked; now add a seam to the lower portion of the back and add the same to the yoke.

The forepart is made in the same way. From K to J is 1 inch; I is halfway between H and J; from H to C is  $\frac{1}{2}$  inch; K to D is the same; cut the pattern through as from C to I and from I to D; add a seam to the lower part of the front and the same to the yoke.

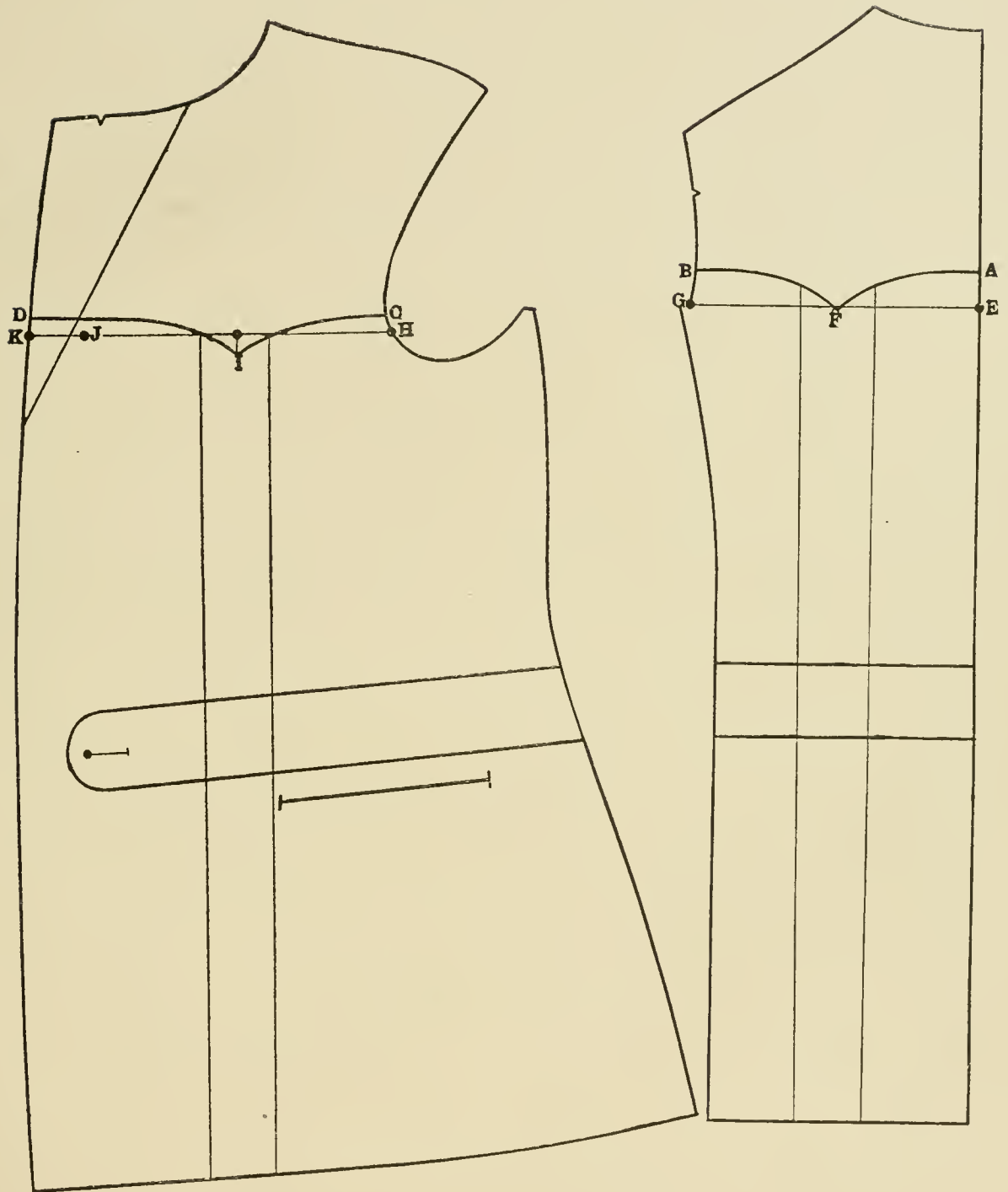

DIAGRAM 167

## DIAGRAM 168

## NORFOLK COAT

After the back and forepart are cut out proceed as follows: cut off your yoke as marked on the forepart and backpart; this may be cut according to taste. Add a seam each to the yoke and to the lower part; line 1-2 on the backpart represents about the center of the back; split the pattern down as from 1 to 2, also through the waistline as 2-3.

Now take a thin piece of paper, crease it over in either two or three plaits or as many as desired. Lay the piece that has been cut out off the backpart on the folded piece and cut it according to the original pattern. That piece when opened up should look as shown here 1, 2, 3 and 4.

## THE FOREPART

Split the forepart as from D to E, E to B and B to A; now take a piece of soft paper and fold in plaits as explained on the backpart; then take the piece that is cut from the forepart and place it on the plaited piece; cut it out in accordance with the original piece; adding seams as at A-C and B-E. Now set the piece back in again as the broken line shows and sew the yoke on.

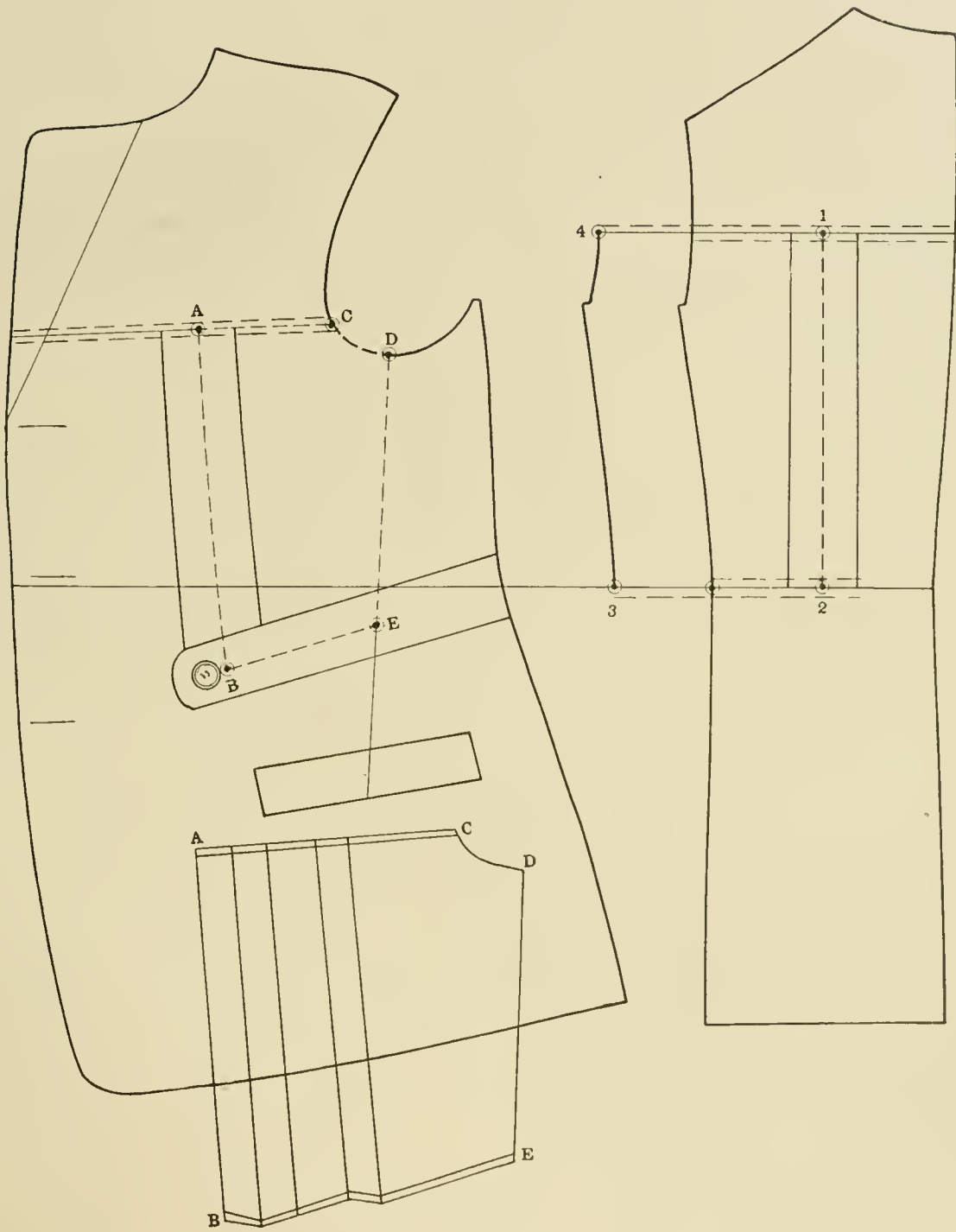

DIAGRAM 168



TABLE OF PROPORTIONS  
FROM  
NORMALS TO STOUTS

COAT					VEST	TROUSERS		
BREAST	WAIST	HIP	SLEEVE	COAT LENGTHS	VEST LENGTHS	RISE	WAIST	SEAT
34	30	36	17½	30	24¾	9¼	29	35
35	31	37	17¾	30¼	25⅞	9½	30	36
36	32	38	18	30½	25½	9¾	31	37
37	33¼	39	18¼	30¾	25⅞	10	32¼	38
38	34½	40	18½	31	26¼	10¼	33½	39
39	35¾	41	18¾	31¼	26⅝	10½	34¾	40
40	37	42	19	31½	27⅞	10¾	36	41
41	38¼	43	19¼	31¾	27½	11	37¼	42
42	39½	44	19½	32	27⅞	11¼	38½	43
43	40¾	45	19½	32¼	28¼	11½	39¾	44
44	42	46	19½	32½	28½	11¾	41	45
45	43¼	47	19½	32¾	28⅞	12	42¼	46
46	44½	48	19½	33	28¾	12¼	43½	47
47	45¾	49	19½	33¼	28⅞	12½	44¾	48
48	47	50	19½	33½	29	12¾	46	49
49	48¼	51	19½	33¾	29⅞	13	47¾	50
50	49½	52	19½	34	29¼	13¼	48½	51

TABLE OF PROPORTIONS  
FROM  
STOUT TO CORPULENTS

COATS			TROUSERS			
BREAST	WAIST	HIP	WAIST	HIP	SEAT	RISE
38	37	41	36	40	40	10
39	38¼	42	37¼	41¼	41	10¼
40	39½	43	38½	42½	42	10½
41	40¾	44	39¾	43¾	43	10¾
42	42	45	41	45	44	11
43	43¼	46	42¼	46¼	45	11¼
44	44½	47	43½	47½	46	11½
45	45¾	48	44¾	48¾	47	11¾
46	47	49	46	50	48	12
47	48¼	50	47¼	51¼	49	12¼
48	49½	51	48½	52½	50	12½
49	50¾	52	49¾	53¾	51	12¾
50	52	53	51	55	52	13
51	53¼	54	52¼	56	53	13¼
52	54½	55	53½	57	54	13½
53	55¾	56	54¾	58	55	13¾
54	57	57	56	59	56	13½

For vest lengths add ¼ of breast and ¼ of height.

The short measures for the table of proportions for men are as follows:

Scye depth, ⅓ breast plus 3¼ inches; Waist length, ¼ of height; For fashionable waist length, add 2 inches; Strap, ¼ breast plus 3¾ inches; Blade, ¼ breast plus 3½ inches; For overshoulder use ⅓ of breast plus 6 inches.

Where changes are made in either the scye depth, strap or blade, for either stooping or over erect forms, the overshoulder is obtained as follows:

For example:

Scye depth .....	9¼ inches
Strap .....	12¾ inches
Blade .....	12½ inches

Total .....

31½ inches  
Take one-half of the amount, which is 15¾ inches and add ¼ inch, which is 17½ inches.  
Make no extra additions, as all allowances have been made.

AMERICAN GARMENT CUTTER  
TABLE OF PROPORTIONS  
FOR  
BOYS AND YOUTHS

COATS

AGE	BREAST	WAIST	HIP	WAIST LENGTH	FULL LENGTH	SLEEVE	WRIST
4	23	23	26	11 $\frac{1}{3}$	18	17 $\frac{1}{2}$	8 $\frac{1}{2}$
5	23 $\frac{3}{4}$	23 $\frac{1}{2}$	26 $\frac{5}{8}$	11 $\frac{2}{3}$	18 $\frac{5}{8}$	18 $\frac{1}{2}$	8 $\frac{3}{4}$
6	24 $\frac{1}{2}$	24	27 $\frac{1}{4}$	12	19 $\frac{1}{4}$	19 $\frac{1}{2}$	9
7	25 $\frac{1}{4}$	24 $\frac{1}{2}$	27 $\frac{7}{8}$	12 $\frac{1}{3}$	19 $\frac{7}{8}$	20 $\frac{1}{2}$	9 $\frac{1}{4}$
8	26	25	28 $\frac{1}{2}$	12 $\frac{2}{3}$	20 $\frac{1}{2}$	21 $\frac{1}{2}$	9 $\frac{1}{2}$
9	26 $\frac{3}{4}$	25 $\frac{1}{2}$	29 $\frac{1}{8}$	13	21 $\frac{1}{8}$	22 $\frac{1}{2}$	9 $\frac{3}{4}$
10	27 $\frac{1}{2}$	26	29 $\frac{3}{4}$	13 $\frac{1}{3}$	21 $\frac{3}{4}$	23 $\frac{1}{2}$	10
11	28 $\frac{1}{4}$	26 $\frac{1}{2}$	30 $\frac{3}{8}$	13 $\frac{2}{3}$	22 $\frac{3}{8}$	24 $\frac{1}{2}$	10 $\frac{1}{4}$
12	29	27	31	14	23	25 $\frac{1}{2}$	10 $\frac{1}{2}$
13	29 $\frac{3}{4}$	27 $\frac{1}{2}$	31 $\frac{5}{8}$	14 $\frac{1}{3}$	23 $\frac{3}{4}$	26 $\frac{1}{4}$	10 $\frac{3}{4}$
14	30 $\frac{1}{2}$	28	32 $\frac{1}{4}$	14 $\frac{2}{3}$	24 $\frac{1}{2}$	27	11
15	31 $\frac{1}{4}$	28 $\frac{1}{2}$	33	15	25 $\frac{1}{4}$	27 $\frac{3}{4}$	11 $\frac{1}{4}$
16	32	29	33 $\frac{3}{4}$	15 $\frac{1}{3}$	26	28 $\frac{1}{2}$	11 $\frac{1}{2}$
17	33	29 $\frac{1}{2}$	34 $\frac{1}{2}$	15 $\frac{2}{3}$	26 $\frac{3}{4}$	29 $\frac{1}{4}$	11 $\frac{3}{4}$
18	34	30	35	16	27 $\frac{1}{2}$	30	12
19	35	31	36	16 $\frac{1}{3}$	28 $\frac{1}{4}$	31	12 $\frac{1}{4}$
20	36	32	37	16 $\frac{2}{3}$	29	32	12 $\frac{1}{2}$

TROUSERS

AGE	BOYS' VESTS	RISE	LENGTH	WAIST	SEAT	KNEE
4		5 $\frac{1}{2}$	5 $\frac{1}{4}$	23	25 $\frac{1}{2}$	11
5		5 $\frac{3}{4}$	6 $\frac{1}{8}$	23 $\frac{1}{2}$	26 $\frac{1}{4}$	11 $\frac{1}{4}$
6		6	7	24	27	11 $\frac{1}{2}$
7		6 $\frac{1}{4}$	7 $\frac{7}{8}$	24 $\frac{1}{2}$	27 $\frac{3}{4}$	11 $\frac{3}{4}$
8		6 $\frac{1}{2}$	8 $\frac{3}{4}$	25	28 $\frac{1}{2}$	12
9		6 $\frac{3}{4}$	9 $\frac{5}{8}$	25 $\frac{1}{2}$	29 $\frac{1}{8}$	12 $\frac{1}{4}$
10	21 $\frac{3}{4}$	7	10 $\frac{1}{2}$	26	29 $\frac{3}{4}$	12 $\frac{1}{2}$
11	22 $\frac{1}{8}$	7 $\frac{1}{4}$	11 $\frac{3}{8}$	26 $\frac{1}{2}$	30 $\frac{3}{8}$	12 $\frac{3}{4}$
12	22 $\frac{1}{2}$	7 $\frac{1}{2}$	12 $\frac{1}{4}$	27	31	13
13	22 $\frac{7}{8}$	7 $\frac{3}{4}$	13 $\frac{1}{8}$	27 $\frac{1}{2}$	31 $\frac{5}{8}$	13 $\frac{1}{4}$
14	23 $\frac{1}{4}$	8	14	28	32 $\frac{1}{4}$	13 $\frac{1}{2}$
15	23 $\frac{5}{8}$	8 $\frac{1}{4}$	14 $\frac{3}{4}$	28 $\frac{1}{2}$	33	13 $\frac{3}{4}$
16	24	8 $\frac{1}{2}$	15 $\frac{1}{2}$	29	33 $\frac{3}{4}$	14
17	24 $\frac{3}{8}$	8 $\frac{3}{4}$	30 $\frac{1}{2}$	29 $\frac{1}{2}$	34 $\frac{1}{2}$	11 $\frac{1}{2}$ (Bottom)
18	24 $\frac{3}{4}$	9	31	30	35 $\frac{1}{4}$	15
19	25 $\frac{1}{8}$	9 $\frac{1}{4}$	31 $\frac{1}{2}$	31	36	15 $\frac{1}{2}$
20	25 $\frac{1}{2}$	9 $\frac{1}{2}$	32	32	37	16

The short measures for the table of proportions for children's clothing are as follows:  
Sleeve depth,  $\frac{1}{4}$  breast; strap,  $\frac{1}{3}$  breast plus  $\frac{3}{4}$  inch; blade,  $\frac{2}{3}$  breast plus  $\frac{1}{2}$  inch.  
Make no extra additions, as all allowances have been made.



## A FEW REMARKS ABOUT MAKING COATS.

The canvas and haircloth for all coats should be cut on the bias as shown on Diagram A; cut in this way, it will give freely at the gorge, shoulder and armhole. Some tailors consider the canvas on the bias when cut as shown on Diagram B; this is the wrong way, because if cut in this way it will be on the straight around the gorge, shoulder and armhole, and unless cut in at several places will produce a stiffness and will not give at the shoulder and armhole as it should.

**Sack Coats**—Before sewing up the side seams it is well to shrink in the back from about four inches below the armhole to the shoulder so as to form a pocket for the blade bone, also put in a piece of stay linen at the back of the armhole so as to keep the blade pocket in place. If a close-fitting sack coat, you may stretch the backpart slightly at the waist. On a straight hanging sack coat or overcoat the backpart must not be stretched at the waist. In pressing the canvas, stretch it slightly at the gorge and shoulder, but do not stretch the cloth because the fulling in of the back at the shoulder seam, also the fulling in of the collar will give all the stretching needed.

**The Edges**—Always dip the stay tape in water and press before using it. When basting stay tape on the front edge, hold it short over the breast and work the front edge in, so that the roundness of the breast is pressed into the middle of the front and the edge becomes straight. For a stout person, hold the stay tape short over the most prominent rounding, which is over the waist. In all straight front coats, such as overcoats, double-breasted sacks, or straight-front sacks, the front edges must be worked in until they are straight.

**The Sleeves**—In sewing up the front seams always begin at the top, and, basting on the upper sleeve, keep both upper and under sleeves even for about 3 inches; from there down, hold the upper sleeve a little short to about 3 inches from the bottom and from there down, hold them even. When sewing up the back seam, begin also on top, and basting on the upper sleeve, keep them both even to the elbow; over the roundness of the elbow hold the upper sleeve easy, and from there down even.

When basting in the sleeve, begin with the right one and placing the seam of the sleeve to the notch of the back hold it easy to about 1 inch beyond the shoulder seam; from there on full the sleeve in until the front notch of the sleeve reaches the front notch of the armhole; from there hold the sleeve even until you reach the part of the armhole that is drawn in with the stay linen and full the undersleeve in over the back.

**The Collar**—Collars are to be put in easy in the hollow of the gorge for normal or slim persons. A concave shoulder needs a longer collar than a normal shoulder. A stout person needs a shorter collar than a normal person. In either case, don't stretch the collar stand.

## FROCKS

In basting the sidebody to the front always begin and keep them even at the armhole and hold straight all the way down.

## THE SKIRT

After the sideseam and fish are sewed and pressed open, baste a piece of stay tape to the bottom, or the waist seam of the sidebody, so as to prevent it from stretching, after which baste the skirt on, beginning at the side, hold the skirt and sidebody even to the side seam. From there on for about 4 inches hold the skirt full, and from there on even to the front.

In sewing the back to the sidebody, begin at the armhole and keep both back and sidebody even to about 4 inches from the waist; from there down full the back in about  $\frac{1}{4}$  inch; **don't stretch the sidebody** until after the back is sewed on to it, and then only just enough to make the backseam straight; shrink in the sidebody halfway.

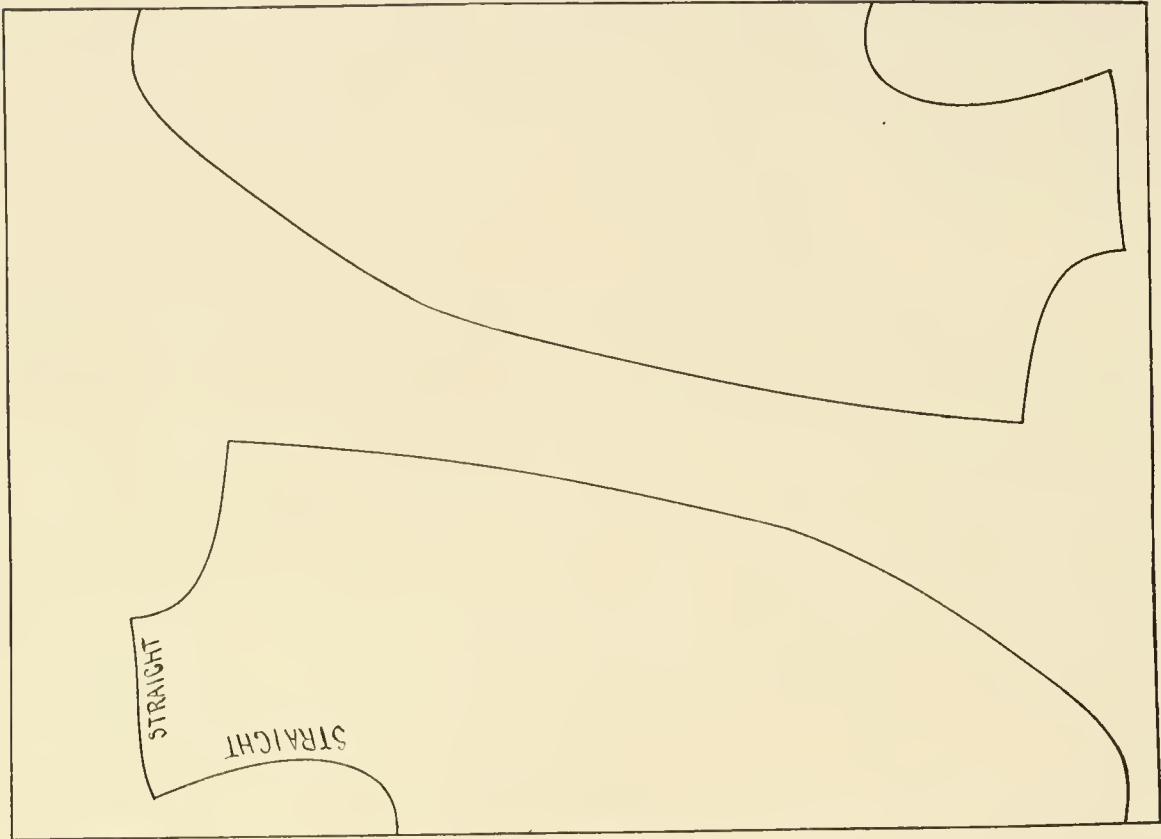

B

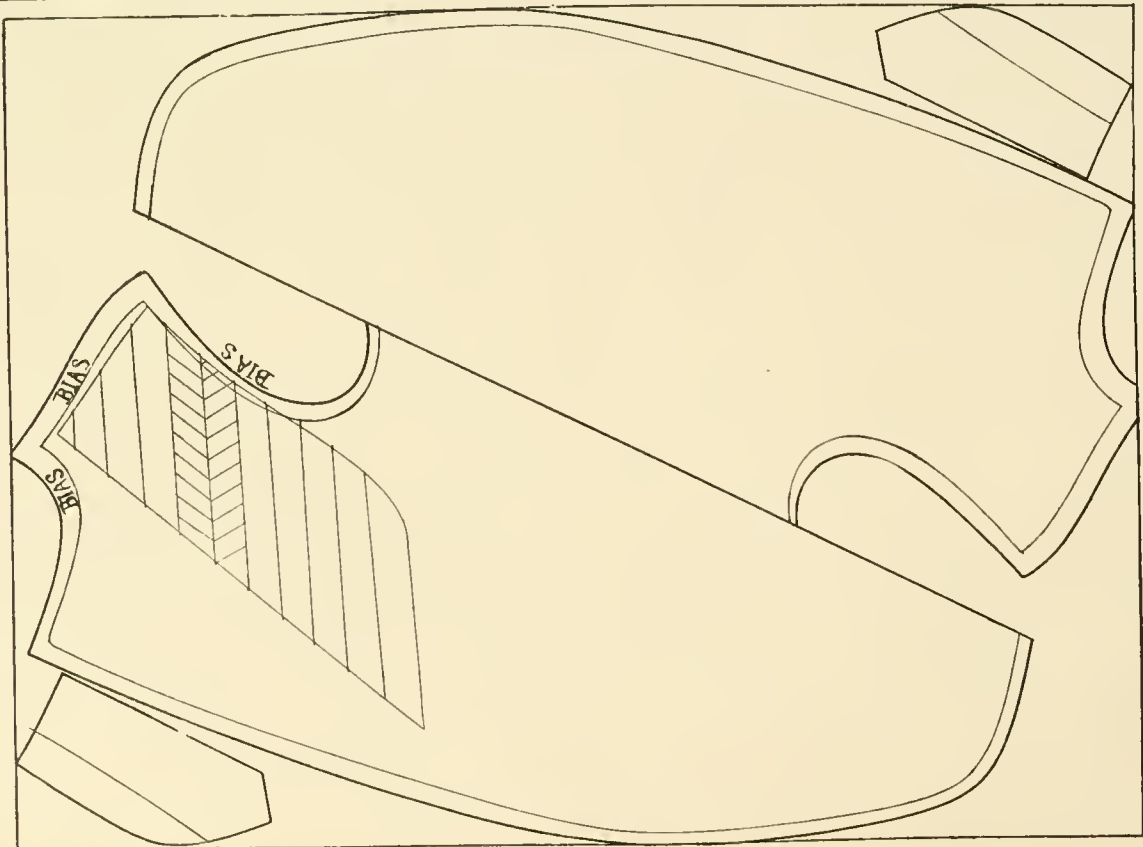

A

10.

### THE PLAITS

The proper way to make plaits is to put a baste in  $\frac{1}{4}$  inch or a seam back from the mark stitch and press the roundness of the skirt in until the plait is straight; then press it open as if it were a seam. Pull the baste out and it is ready to be joined to the back.

The shoulder, collar and sleeves are the same as in the sack coats.

In double-breasted frocks or dress coats all the seams are joined the same as the single-breasted coats, except that the rever is held slightly short over the breast and the bell shape skirt needs but little fulness at the waist.

### VESTS

All vests cut by this system need no collar stand, as the stand is cut on the vest.

**The Edges**—All the front edges are to be made straight with the stap tape, *i. e.*, they are to be worked in until the edge is straight and the fullness pressed into the middle of the front.

**The Shoulders**—The shoulders ought to be stretched slightly and the back held full over them. The Collar, if there be one, should be held easy to about 3 inches from the shoulder and from there held short to about 2 inches from the front edge.

Double-breasted vests, with or without collar, or dress vests with low openings should have stay tape laid around the opening and held short so as to prevent the edge sticking away from the shirt front.

Double-breasted vests and double-breasted coats must have more breast worked in them than single-breasted vests or coats.

### TROUSERS

Avoid stretching trousers, except in the backpart from the knee up and that but slightly. Any stretching on the forepart is sure to spoil them. Let the notches come together evenly; hold the forepart easy over the knee and the backpart hold easy over the calf.

Peg top trousers should have the roundness from over the hip pressed into the back; let the forepart be held easy over the backpart from the hip to the knee; waistbands should be held a little short over the forepart, easy in hollow of the waist and even from there back; the right fly should be held easy in the hollow of the crotch. Let all the shaping be done by shrinking. Do not stretch.

# I N D E X

	Page		Page		Page
INTRODUCTION .....	3	CLERGYMAN'S STRAIGHT-FRONT FROCK .....	94	FOOTMAN'S COATEE .....	204
PREFACE .....	4	CASSOCK .....	96	MESS JACKET .....	206
PREFACE TO THIRD EDITION .....	5	CLERGYMAN'S STRAIGHT-FRONT SACK .....	98	CHAUFFEUR'S SACK .....	208
THE MEASURING OF THE HUMAN BODY .....	6	DOUBLE-BREASTED FROCK .....	100	CHAUFFEUR'S OVERCOAT .....	210
HOW TO MEASURE .....	8	DOUBLE-BREASTED FROCK FOR A STOUT FIGURE .....	102	RIDING SACK .....	212
HOW TO MEASURE, Continued .....	10	DOUBLE-BREASTED FROCK FOR A CORPULENT FIGURE .....	104	RIDING SACK, Continued .....	211
HOW TO MEASURE, Continued .....	12	EVENING DRESS COAT .....	106	RIDING FROCK .....	216
HOW TO MEASURE, Continued .....	11	EVENING DRESS COAT WITH REVER AND SKIRT STRAP IN ONE .....	110	COLLARS .....	218
HOW TO MEASURE, Continued .....	16	EVENING DRESS COAT, Continued .....	112	SINGLE-BREASTED NO-COLLAR WAISTCOAT .....	220
HOW TO MEASURE, Continued .....	18	SINGLE-BREASTED OVERCOAT .....	114	SINGLE-BREASTED WAISTCOAT WITH NOTCH COLLAR .....	222
HOW TO MEASURE, Continued .....	20	SINGLE-BREASTED SHAPELY OVERCOAT .....	116	WAISTCOAT FOR A FIGURE WITH A LARGE BLADE .....	221
FIRST LESSON FOR DRAFTING A SACK COAT .....	22	SINGLE-BREASTED SHAPELY OVERCOAT, Continued .....	118	WAISTCOAT FOR A FIGURE WITH A FLAT BLADE AND FULL CHEST .....	221
FIRST LESSON FOR DRAFTING A SACK COAT, Continued .....	24	SHAPELY OVERCOAT FOR A STOUT FIGURE .....	120	DOUBLE-BREASTED WAISTCOAT .....	226
FIRST LESSON FOR DRAFTING A SACK COAT, Continued .....	26	DOUBLE-BREASTED OVERCOAT FOR STOUT FIGURE .....	122	WAISTCOAT CUT WITH SEPARATE REVER .....	228
HOW TO APPLY THE OVERSHOULDER MEASURE .....	28	SINGLE-BREASTED LOOSE-HANGING OVERCOAT .....	121	SINGLE-BREASTED NO-COLLAR VEST FOR A STOUT FIGURE .....	230
HOW TO MAKE THE CHANGE FOR A LOW SHOULDER .....	30	STRAIGHT-HANGING OVERCOAT FOR A STOUT FIGURE .....	126	SINGLE-BREASTED NO-COLLAR VEST FOR A STOUT FIGURE, Continued .....	232
SACK COAT FOR A FIGURE WITH A LARGE BLADE .....	32	DOUBLE-BREASTED ULSTER .....	128	SINGLE-BREASTED WAISTCOAT FOR A CORPULENT FIGURE .....	234
SACK COAT FOR A FIGURE WITH A SMALL BLADE .....	34	SINGLE-BREASTED BOX OVERCOAT .....	130	DOUBLE-BREASTED WAISTCOAT FOR A STOUT FIGURE .....	236
TO CAUSE A SMALL FOLD AT THE BACK OF THE ARM .....	36	BOX OVERCOAT FOR A STOUT FIGURE .....	132	DOUBLE-BREASTED WAISTCOAT FOR A STOUT FIGURE, Continued .....	228
TO INCREASE THE WIDTH OF THE SHOULDER .....	38	BOX OVERCOAT FOR A STOUT FIGURE, Continued .....	134	SINGLE-BREASTED DRESS WAISTCOAT .....	240
SACK COAT FOR A SWAY-BACK FIGURE .....	40	DOUBLE-BREASTED OVERCOAT FOR A STOUT FIGURE .....	136	DOUBLE-BREASTED DRESS WAISTCOAT .....	242
TO CUT AN INCREASED SIZE COAT WITHOUT DISTURBING THE BALANCE .....	42	SINGLE-BREASTED FROCK OVERCOAT .....	138	CLERGYMAN'S WAISTCOAT .....	244
FOUR-BUTTON STRAIGHT-HANGING SACK BOX SACK COAT .....	46	SINGLE-BREASTED FROCK OVERCOAT FOR A STOUT FIGURE .....	140	CLERGYMAN'S WAISTCOAT, Continued .....	246
THREE-BUTTON STOUT MAN'S SACK .....	48	SINGLE-BREASTED PADDOCK OVERCOAT .....	142	CLERGYMAN'S WAISTCOAT, Continued .....	248
HOW TO POCKET A FAT MAN'S COAT .....	50	DOUBLE-BREASTED PALETOT .....	144	SINGLE-BREASTED WAISTCOAT FOR A HUNCH-BACK .....	250
THREE-BUTTON SACK COAT FOR A CORPULENT FIGURE .....	52	DOUBLE-BREASTED FROCK OVERCOAT .....	146	TROUSERS .....	252
DOUBLE BREASTED SACK COAT .....	54	DOUBLE-BREASTED FROCK OVERCOAT FOR A CORPULENT FIGURE .....	148	STOUT MAN'S TROUSERS .....	254
DOUBLE-BREASTED SACK COAT FOR A STOUT FIGURE .....	56	SHELL FOR FUR COAT .....	150	PEG-TOP TROUSERS .....	256
THREE-BUTTON SACK COAT FOR A HUNCH-BACK .....	58	THE SLEEVE .....	152	TROUSERS WITH LARGE LEGS .....	258
SHAWL COLLAR TUXEDO .....	60	THE SLEEVE, Continued .....	151	SPRING-BOTTOM TROUSERS .....	260
PEAKED LAPEL TUXEDO .....	62	SLEEVE FOR BOX OVERCOAT .....	156	HOW TO MANIPULATE A PAIR OF TROUSERS FOR BACK BOW .....	260
HOW TO GET A HIGH BACK SEAM .....	64	SLEEVE FOR A NARROW SHOULDER .....	158	BROAD AND NARROW FALLS .....	262
FROCK COAT .....	66	RAGLAN OVERCOAT .....	160	TROUSERS FOR BOW-LEGGED MEN .....	264
THREE-BUTTON FROCK, Continued .....	68	THE SPLIT SLEEVE .....	162	RIDING BREECHES .....	266
TO PROCURE THE PROPER SEAMS ON A FROCK COAT .....	70	THE WHOLE SLEEVE .....	162	RIDING BREECHES WITHOUT EXTENSIONS .....	268
HOW TO CHANGE A FROCK COAT PATTERN FOR A LOW SHOULDER .....	72	BALMACAAN .....	164	COACHMAN'S BREECHES .....	270
FIGURE WITH A FLAT BLADE AND A FULL CHEST .....	74	BALMACAAN, Continued .....	166	KNICKERBOCKERS .....	272
FIGURE WITH A LARGE BLADE AND A FLAT CHEST .....	76	BALMACAAN, Continued .....	168	GOLFING BREECHES .....	274
THREE-BUTTON FROCK .....	78	BALMACAAN, Continued .....	170	STRAIGHT FRONT SACK FOR A BOY 6 YEARS OF AGE .....	276
THREE-BUTTON SACK FOR AN ATHLETE FROCK COAT FOR A LARGE BREST, SMALL WAIST AND SLIGHTLY SWAY-BACK .....	80	BALMACAAN SLEEVE .....	172	DOUBLE-BREASTED SACK FOR A BOY, 12 YEARS (Increased 2 sizes) .....	278
FROCK COAT, Continued .....	82	BALMACAAN SPLIT SLEEVE .....	171	SINGLE-BREASTED OVERCOAT FOR A BOY 10 YEARS .....	280
THREE-BUTTON FROCK FOR STOUT FIGURE .....	84	SLEEVE, Continued .....	176	DOUBLE-BREASTED BOX OVERCOAT FOR A BOY 16 YEARS .....	282
THREE-BUTTON FROCK FOR A CORPULENT FIGURE .....	86	TWO SEAM SPLIT SLEEVE .....	178	BOY'S SLEEVES AND TROUSERS .....	284
ENGLISH WALKING FROCK WITH SACK FRONT .....	88	SLEEVE, Continued .....	180	NORFOLK COAT .....	286
SINGLE-BREASTED STRAIGHT-FRONT FROCK .....	90	INVERNESS .....	182	NORFOLK COAT, Continued .....	288
SINGLE-BREASTED STRAIGHT-FRONT FROCK FOR A STOUT FIGURE .....	92	SQUARE-SHOULDERED INVERNESS .....	181	TABLE OF PROPORTIONS, FOR SHORT MEASURES BY BRESTS & HEIGHTS .....	290
		SHOULDER CAPE .....	186	TABLE OF PROPORTIONS FROM NORMALS TO STOUTS .....	291
		SHOULDER CAPE, Continued .....	188	TABLE OF PROPORTIONS FROM STOUTS TO CORPULENTS .....	292
		SPANISH CAPE .....	190	A FEW REMARKS ABOUT GARMENT MAKING .....	293
		MILITARY CAPE .....	192	REMARKS ON COAT MAKING, Continued .....	294
		A HOOD .....	191	REMARKS ON COAT MAKING, Continued .....	295
		NAVAL OFFICER'S BLOUSE .....	196		
		COACHMAN'S OR GROOM'S FROCK UNDERCOAT .....	198		
		COACHMAN'S FROCK OVERCOAT .....	200		
		FOOTMAN'S OR DOORMAN'S DRESS COAT .....	202		



} b. }



LIBRARY OF CONGRESS

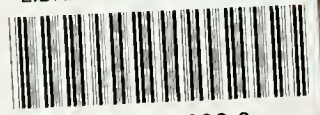

0 014 082 908 0

