

ar v
18684

*ELEMENTS OF
RADIO TELEPHONY*

WILLIAM C. BALLARD, JR.

arv
18684

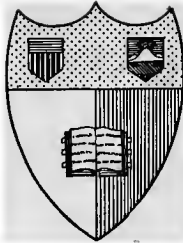

Cornell University Library
Ithaca, New York

FROM

The Author

.....

.....

.....

Cornell University Library

arV18684

Elements of radio telephony,



3 1924 031 239 589

olin,anx

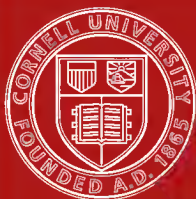

Cornell University Library

The original of this book is in
the Cornell University Library.

There are no known copyright restrictions in
the United States on the use of the text.

<http://www.archive.org/details/cu31924031239589>

ELEMENTS
OF
RADIO TELEPHONY

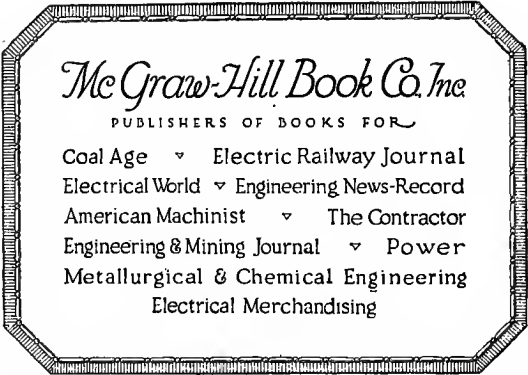

McGraw-Hill Book Co. Inc.

PUBLISHERS OF BOOKS FOR

Coal Age ▽ Electric Railway Journal
Electrical World ▽ Engineering News-Record
American Machinist ▽ The Contractor
Engineering & Mining Journal ▽ Power
Metallurgical & Chemical Engineering
Electrical Merchandising

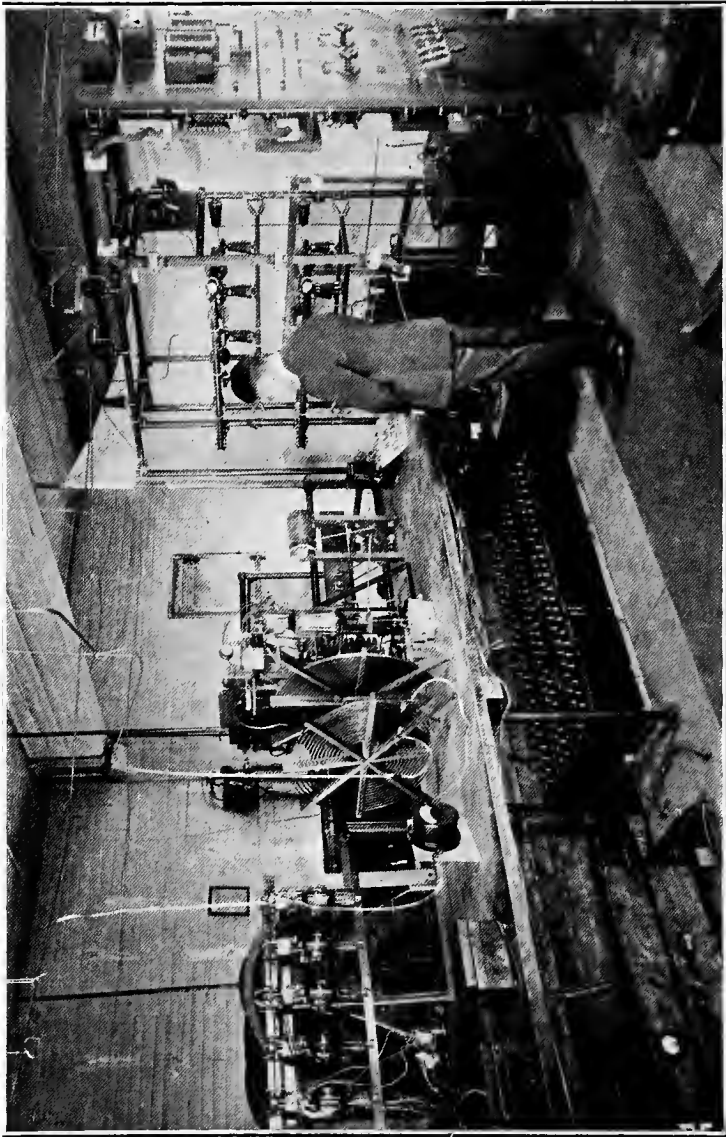

Interior of the Broadcasting Station of the General Electric Company at Schenectady, N. Y. The plate voltage is produced by rectifying both halves of the waves from all three phases of a three-phase supply system. The six rectifier tubes can be seen a few feet to the operator's right.

ELEMENTS
OF
RADIO TELEPHONY

BY
WILLIAM C. BALLARD, JR., M.E.
ASSISTANT PROFESSOR OF ELECTRICAL ENGINEERING
CORNELL UNIVERSITY

FIRST EDITION

McGRAW-HILL BOOK COMPANY, INC.
NEW YORK: 370 SEVENTH AVENUE
LONDON: 6 & 8 BOUVERIE ST., E. C. 4

1922

w

COPYRIGHT, 1922, BY THE
MCGRAW-HILL BOOK COMPANY, INC

PREFACE

The phenomenal popularity into which radio telephonic broadcasting has sprung has been the means of interesting thousands in radio transmission. To the non-technical reader the transmission of speech and music with no visible means of intercommunication is somewhat of a mystery. While it is mysterious it is no more mysterious than the production and recognition of light, for radio and light waves are of exactly the same nature. The relation of radio and light waves is the same as that existing between red and blue light, it is merely a matter of frequency. Of course the "colors" of the radio spectrum are invisible as far as the human eye is concerned and the radio receiver is nothing more than an artificial eye sensitive to these extremely low-frequency "colors."

This little volume has a three-fold purpose: first, to present in simplified form a brief discussion of what happens when messages are sent and received by radio; secondly a brief, simplified description of the apparatus required to produce these effects and how it operates; and lastly, practical unbiased information for the experimenter who desires certain results but who does not know what apparatus is necessary.

The use of mathematics has been almost entirely avoided and the treatment in most cases is qualitative rather than quantitative. For those readers who are interested in the calculation of the numerical constants of the circuits shown in the book, Circular No. 74 of the Bureau of Standards

entitled "Radio Instruments and Measurements" will be found to contain valuable material. This circular may be obtained from the Superintendent of Documents, Government Printing Office, Washington, D. C.

The usual conventions have been used in the circuit diagrams. For the sake of simplicity filament-regulating resistances have been omitted from all tube diagrams. The diagrams illustrating the currents and voltages in detector circuits are not intended to represent oscillograph records but have been conventionally represented.

The author is indebted to his colleague B. K. Northrop for many valuable suggestions in the preparation of the manuscript and to the American Radio and Research Corporation, the General Electric Company, the Westinghouse Electric and Manufacturing, and the Mullard Radio Valve Co., London, England, for photographs of radio apparatus.

W. C. B.

CORNELL UNIV., ITHACA, N. Y.
May, 1922.

CONTENTS

PREFACE	PAGE V
-------------------	-----------

CHAPTER I

WIRE AND RADIO TELEPHONE SYSTEMS	1
The Telephone Receiver and Transmitter—Comparison between the Two Systems.	

CHAPTER II

HIGH-FREQUENCY CURRENTS AND THEIR PRODUCTION	6
Alternating Currents—Sound, Heat and Light and Their Relation to Radio Waves—Damped and Sustained Waves—Spark Transmitters—Arc Transmitters—Alternator Transmitters— Tube Transmitters.	

CHAPTER III

VACUUM TUBES	14
The Physics of Electron Emission from the Filament—Fleming Valve—Space Charge—Grid Electrode and Its Effect— Tungsten and Coated Filaments.	

CHAPTER IV

VACUUM TUBE OSCILLATORS	24
Mechanical Examples of Oscillation—Self-excited Tube Circuits— Various Systems of Feedback Coupling—Wave Length of Resultant Oscillations—Plate Voltage Supply Systems—Direct current Generators—Rectifier Systems—Hot Cathode Rectifiers—Cold Cathode Rectifiers—Electrolytic Rectifiers—Filter Condensers— Electrolytic Condensers—Master Oscillator and Power Amplifier.	

CHAPTER V

PAGE

MODULATOR SYSTEMS	47
Function of Modulator—Modulation by Antenna Control— Microphone in Antenna Circuit—Magnetic Modulator— Modulation by Variation of Tube Output—Plate Circuit Modulation—Grid Circuit Modulation.	

CHAPTER VI

RECEIVING EQUIPMENT	55
Sympathetic Vibration—Radio Tuning—Electrical Equiva- lent of the Antenna—Crystal Detector Receivers—Loose Coupler Circuits—Vacuum Tube Detector—Action with and without Grid Condenser—"Soft" Tubes—Regenerative Receivers—Single Circuit Receiver—Coupled Circuit Re- ceiver—Methods of Adjustment—Audio Frequency Amplifiers —Radio Frequency Amplifiers—Loud Speakers—"Push-Pull" Amplifier Circuit.	

CHAPTER VII

TRANSMISSION	98
The Antenna—Production of Ether Waves—Relation between Frequency and Wave Length—Elevated Antennae—Antenna Construction—Masts—Wire—Ground Systems—Loop or Coil Antennae—Transmission Range—"Fading"—Atmospherics or "Static."	

CHAPTER VIII

MISCELLANEOUS	116
Storage Batteries—Lead Acid Batteries—Nickel Iron Batteries —Plate Circuit Batteries—Storage Battery Charging Appa- ratus—Wavemeters—Measurement of Transmitter Wave Length—Receiver Circuit Calibration—Selection of Apparatus for Broadcasting Reception—Range of Various Sets—Indoor Antennae—Equipment Using Loop Antennæ—Loud Speakers.	

ELEMENTS OF RADIO TELEPHONY

CHAPTER I

WIRE AND RADIO TELEPHONE SYSTEMS

Wire and Wireless Telephone Systems.—The production of sound depends upon setting the air into suitable vibration. When we speak the vocal chords or membranes located down in the throat vibrate and set the column of air in the throat into vibration and these vibrations are in turn transmitted into the surrounding air. The air waves thus formed beat upon the membrane of the ear and cause it to vibrate in the same manner as the vocal chords did to produce them. The vibration of the membrane of the ear, or the ear drum as we more commonly call it, affects the nerves of the ear and the message is in turn transmitted to the brain.

Transmission over wire or wireless systems is quite similar to the above procedure but instead of using air waves, waves of electric current are employed. Fig. 1 shows a typical telephone circuit which for the sake of simplicity is arranged to transmit only in one direction. *M* is a telephone transmitter or microphone as it is sometimes called. *B* is a battery which supplies the force necessary to send the current around the electric circuit comprising the line wires *L*₁ and *L*₂; *R* is the telephone receiver. The essential parts

of a telephone transmitter are a thin sheet of material, usually metal, called the diaphragm, which is arranged so as to be set into motion when sound waves impinge upon it; and some type of variable resistance contact arranged to be operated by the motion of the diaphragm. The variable resistance contact usually consists of a small chamber in

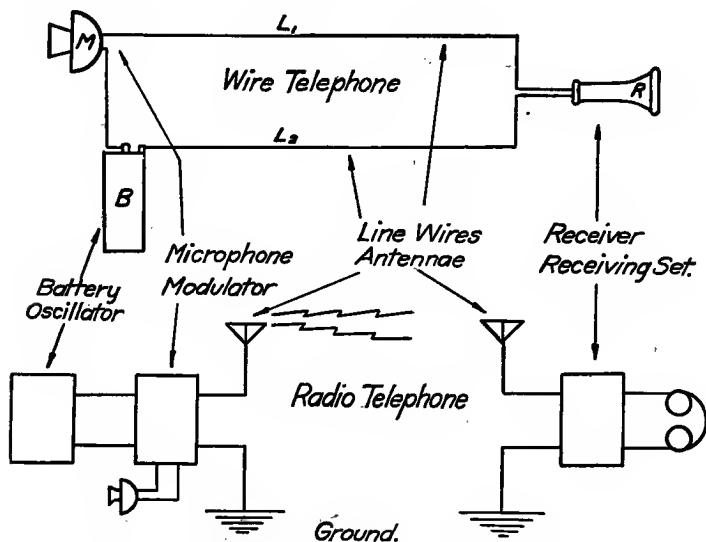

FIG. 1.—Graphical comparison of wire and radio telephone systems.

which two carbon discs are situated and insulated from one another. One disc is stationary and the other is attached to the diaphragm and free to move with it. The space between the two discs is loosely packed with carbon grains about the size of a pin head. The carbon granules have the property of varying the electrical resistance between the two carbon discs, which resistance depends upon the degree of

pressure applied to the granular carbon. When the carbon granules are tightly compressed their resistance is low and

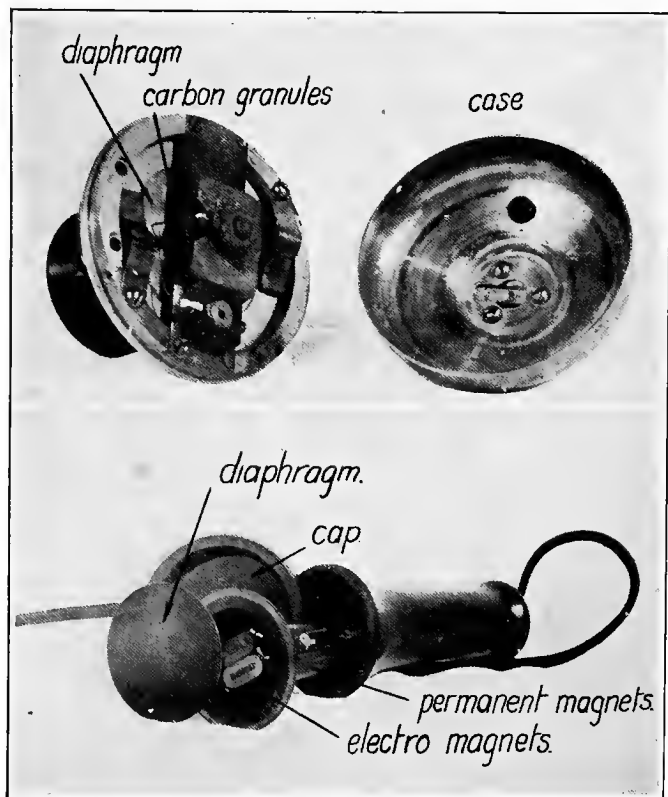

FIG. 2.—Telephone transmitter or microphone and telephone receiver removed from their cases to show internal construction.

this allows the battery to send a comparatively large current through the circuit. When pressure is removed the resistance

increases and the current is correspondingly reduced. Thus the sound waves impressed on the transmitter diaphragm are reproduced in the electrical circuit as changes in the strength of the electric current.

The receiver consists of a thin sheet of soft iron so arranged as to be attracted by an electromagnet. Sometimes this magnet is a combination of permanent and electromagnet and sometimes the permanent magnet is omitted. The coil of wire wound around the iron core constituting the electromagnet has the property of attracting the diaphragm with varying degrees of force depending upon the current through the coil. Since the diaphragm is flexible it will move in response to these changes in pull and thus send out an air wave which resembles to a greater or less degree the current through the coil. The essential features in wire telephony are a source of power, the battery; a modulator of the power source so that the output varies according to the sound to be transmitted, in this case the transmitter or microphone; means for transmitting the modulated power output from the transmitting to the receiving station, represented by the line wires; and finally a device to change the electrical impulses back to sound waves, which is the function of the receiver.

The operation of radio or wireless telephone systems requires corresponding units similar to those already enumerated and which have exactly the same functions. The principal point of difference is that in order to transmit power through the ether, which we have to employ in place of the line wires, it is necessary to use high-frequency energy, and hence the power source will have to be one capable of producing high-frequency currents and the receiving system sensitive to high-frequency currents instead of currents such as are produced in wire telephony. Thus for radio telephony the battery will be replaced by a high-frequency

current generator, the microphone by a modulation system, the line wires by the two antennae and the intervening ether, and the receiver by special receiving apparatus sensitive to high-frequency currents.

Fig. 1 shows these relations in diagrammatic form.

CHAPTER II

HIGH-FREQUENCY CURRENTS AND THEIR PRODUCTION

The current produced in the wire telephone circuit shown in Fig. 1 is what is known as a direct current since it flows always in the same direction. Currents of this general type are used extensively in electrical work, street cars are almost exclusively operated on direct current. Electric lights are usually supplied with alternating current for certain technical reasons. Alternating currents do not flow in any given direction but reverse their direction of flow many times per second. A change from zero through a series of positive or negative values back to zero again is spoken of as an alternation and two alternations compose a cycle. The number of cycles passed through per second is the frequency. These different values are illustrated in Fig. 3, which illustrates the variation of a 60-cycle current with time. It makes no difference where we start or end a cycle or alternation; these values are essentially units of measurement and applicable equally well at any starting point.

The frequency most commonly used on alternating-current power and lighting circuits is 60, and if the filaments of the incandescent lamps could cool off rapidly enough they would actually go out 120 times a second or every time the current passed through zero. However the filament usually stores up enough heat to supply it over the period of zero current and we do not notice any appreciable flicker. In

spite of the heat storage of the filament, flickering is frequently noticeable on 15- and 25-cycle circuits.

The frequencies used in radio work are very much higher than those employed in power work. Radio frequencies range from about 15,000 cycles up to several millions of cycles per second.

Sound waves are alternating air currents or disturbances in the air while radio waves are alternating disturbances in the "ether." Sound waves are mechanical disturbances

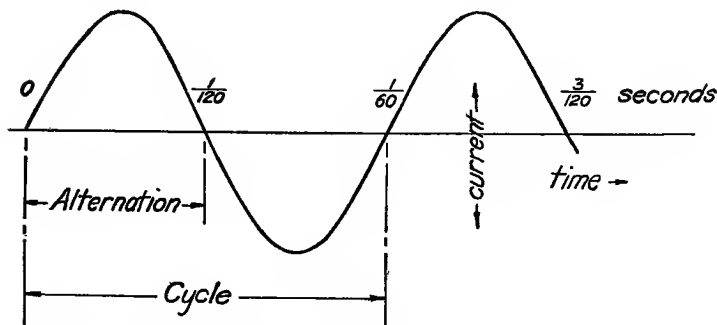

FIG. 3.—Alternating-current wave of 60 cycles frequency.

while radio waves are electromagnetic disturbances. Light and heat are electromagnetic "ether" disturbances similar to radio waves but of very much higher frequencies. Fig. 4 has been drawn with the idea of comparing the various sound and electromagnetic waves with which we have to deal. A piano keyboard comprises about seven octaves. The frequencies of sound waves corresponding to notes one octave apart bear the relation to two to one. If we double the frequency of any given note we always get the octave above it. The drawing shows an enlarged keyboard with the octaves indicated, it should be very definitely remem-

bered that although marked on the same scale, that there is a fundamental difference between sound and radio, light, and heat waves other than that of difference in frequency. As we increase the frequency from the audible range of the piano we reach the limit to which the ear responds at about 10,000 cycles per second and slightly beyond this value we reach the longest radio waves in use to-day. The upper limit of radio frequencies in ordinary use is about four million cycles and from this point to the longer heat waves is a region utilized only in laboratory experiments. As the heat waves become of higher frequency they pass into visible light

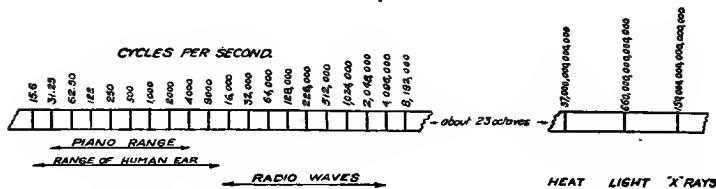

FIG. 4.—Chart showing the relative frequencies of sound, radio, and light waves.

starting at the red end of the "rainbow" or spectrum and finally passing into invisibility through the blue end of the spectrum. Invisible waves of higher frequency than the blue, while having no visible effect on the eye, will affect a photographic plate and produce other manifestations. As we go still higher we come upon the very short waves of high penetrative power known as X-rays. These rays are invisible to the eye but are capable of affecting photographic plates and also produce luminous effects when impinging upon certain chemicals.

Radio and light waves are identical except for the difference in frequency; it so happens that the human eye is sensi-

tive to a rather restricted band of frequencies, otherwise we would be able to see radio signals as flashes of light. Radio telegraph signals would be recognized as alternate flashes of light followed by periods of total darkness and radio telephone signals would correspond to the light given off by a lamp which flickered but never went out entirely. As will be noticed there are several large bands almost entirely unexplored and it is a matter of conjecture just what would

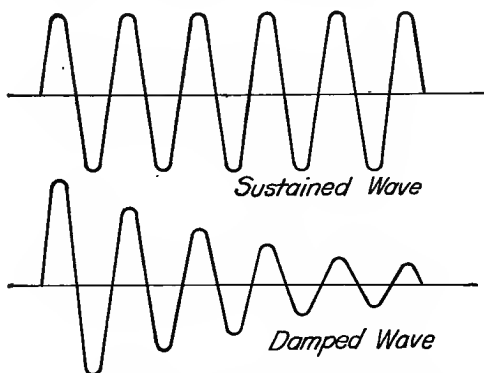

FIG. 5.—Sustained or continuous and damped waves.

be found if radio receiving sets could be tuned to these particular ranges.

Damped and Sustained Waves.—There are two general types of alternating currents useful in radio transmission, (a) those producing sustained waves and (b) those producing damped waves.

In the sustained type the currents vary between constant positive and negative maximum values, each wave being just as high as its neighbor; while in the damped type the waves become smaller and smaller as time goes on. For

instance, an organ pipe produces a sustained sound wave while a piano string produces a damped sound wave which constantly decreases in amplitude. The difference between these two types is illustrated in Fig. 5. Damped waves in general are not of particular interest in radio telephony, their principal application being to radio telegraphy.

There are several different schemes suitable for the production of high-frequency currents applicable to radio communication, some are suitable for both radio telegraphy and telephony while others are adaptable to radio telegraphy alone.

The table below indicates some of the more common systems and their principal applications.

Spark (audible frequency)	Telegraphy.
Spark (inaudible frequency)	Telegraphy and telephony.
Arc	Telegraphy and telephony. (?)
Alternator	Telegraphy and telephony.
Vacuum tube	Telegraphy and telephony.

Spark Systems.—From a numerical standpoint at least, the spark is probably the most important system in use in medium and short distance radio telegraphy. A majority of radio-equipped vessels operate on the spark system, although it may be expected that it will be superseded in the near future on account of certain inherent difficulties in the system.

Since this system is only difficultly applicable to radio telephony it will be but briefly discussed here. It is possible to set up tuned electrical circuits in the same way that we produce tuned conditions in musical instruments. If we tighten the strings on a piano up to the proper point they will sound a certain tone when set into vibration, each tone corresponding to a definite number of cycles per second.

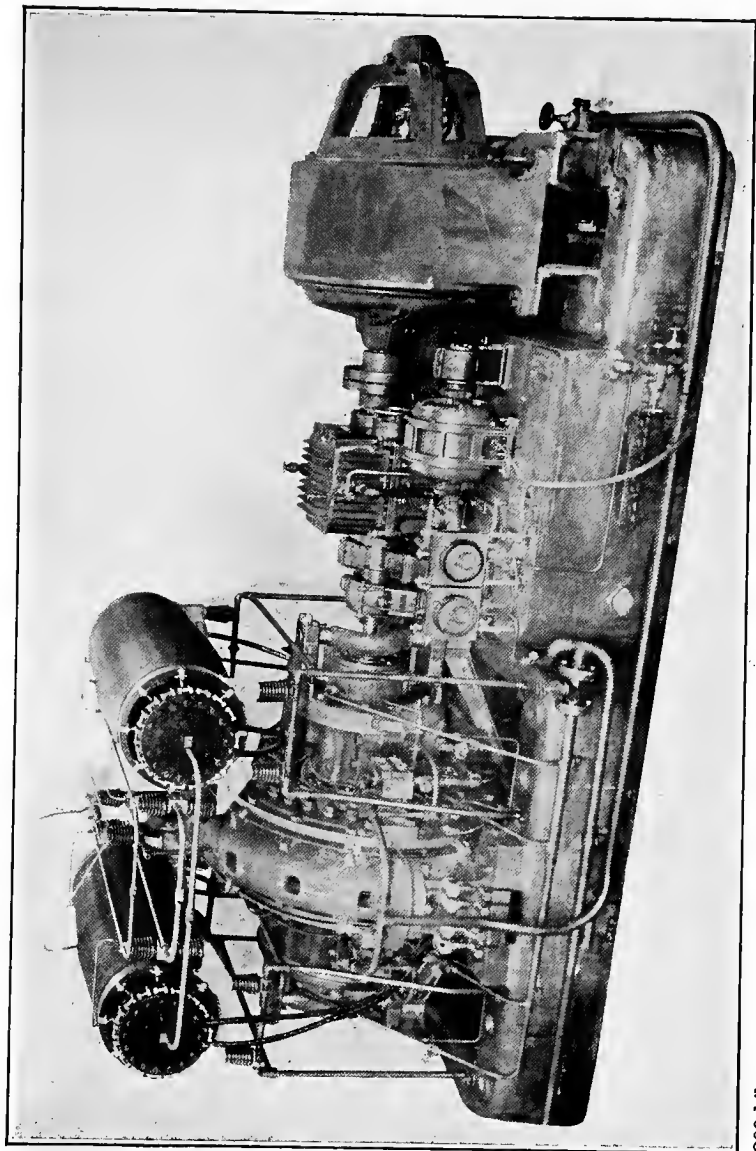

200-kilowatt Alexanderson high-frequency alternator. By modulating the output with a magnetic modulator system, transatlantic radio telephone communication has been established.



The string will continue to vibrate a few seconds after being struck and will gradually die down to rest. The string vibrates because it has both elasticity, which allows it to be stretched taut on the sounding board, and inertia due to the mass of the metal composing the wire. The electrical circuit on the other hand will have capacitance and inductance corresponding to elasticity and mass in the piano string. In order to set it into sudden vibration we insert a spark gap in the circuit and charge the condenser up to the point where the gap breaks down and allows a spark to pass. The spark which passes is not a direct-current discharge as might be expected, but corresponds to a high-frequency alternating current of a frequency determined from the capacitance and inductance of the circuit. This is analogous to the case of the piano string where the frequency of the sound vibration is determined by the tension and weight of the string.

The usual arrangement is to have the high voltage supplied from a transformer, in which case we ordinarily get one spark per alternation, or two sparks per cycle. If the generator frequency is 500, as is the case in most marine installations, there will be a thousand spark discharges per second, one for each positive and negative peak. At each discharge through the air gap, a high-frequency current of several cycles gradually diminishing down to zero, is set up, and by proper connection to the antenna circuit a corresponding ether wave is sent out. By proper arrangement of receiving apparatus at the receiving antenna a note of 1000 cycles will be heard in the telephones.

The transmitter at Arlington which sends daily time signals is operated on this system.

The only way in which this type of transmitter can be used for radio telephony is to increase the spark rate until the spark note comes above the limit of audibility and

under these conditions the output of the system may be modulated for radio telephony as described in a later chapter. The system is not of great practical importance as other systems are superior to it in very many respects.

Arc Systems.—Arc transmitters operating on the Poulsen system are in extensive use for long distance telegraph transmission and are gradually being introduced in smaller sizes for marine work in place of spark transmitters. The electrical principles involved are not greatly different from those involved in spark transmitter operation. In normal arc operation one spark passes for each cycle of high-frequency current, while in spark transmitters there are several cycles for each spark. The arc is supplied with direct current instead of alternating as in the previous case, and produces sustained or undamped waves in contrast with the damped wave produced by the spark transmitter.

The arc is not well suited for radio telephony on account of hissing produced by irregularities of the transmitted wave due to the instability of the arc.

Alternator Systems.—Alternator systems employ apparatus of the same general nature as that used to supply power for power and lighting applications except that instead of generating frequencies around 60, such as are used for power applications, they must be capable of producing frequencies above 10,000 cycles per second. Several different alternator systems have been developed, among which should be mentioned the Alexanderson inductor type in which the high frequency is produced directly in the alternator, the Goldschmidt system in which a relatively low frequency is initially generated in the alternator and reflected back and forth several times between the two windings on the machine with a corresponding increase of frequency at each reflection, and the Joly-Arco system in which the frequency is stepped up in outside stationary apparatus.

Any of the above systems produces an output admirably suited for radio telephony and is subject only to the difficulties involved in controlling the output in accordance with the sound wave which it is desired to modulate. A magnetic modulator has been developed in connection with the Alexanderson system and very successful tests have been carried out by its use.

Tube Systems.—The three-element electron tube variously known as the audion, pliotron, triode, etc., seems to offer the ideal solution of the radio telephone transmission problem, and the results already accomplished indicate an immense field for its further application. In fact the tube may eventually displace all other systems and become the one universal type of radio apparatus. On account of its wide application both in receiving and transmitting circuits, its construction and operation will be treated in a separate chapter.

CHAPTER III

VACUUM TUBES

It has been known in scientific circles for several hundred years that heated bodies exhibit peculiar electrical effects. For example, early investigators found that by bringing a charged electroscope near a red-hot iron ball the electroscope would lose its charge. As a part of his researches in connection with the development of the incandescent lamp, Edison noted that the filament had the power of giving off electricity when heated.

Modern discoveries in physics indicate that all material bodies are composed of minute divisions of matter termed molecules and that these molecules are in constant motion inside the substance. The rapidity with which these particles move and the temperature of the body are thought to be closely related, the higher the temperature the greater the molecular velocity. On the other hand as the temperature is lowered the molecular activity becomes less and less until the molecules come to a standstill at the absolute zero of temperature which corresponds to 273 degrees below zero in the Centigrade scale.

If the molecular structure of a material is such that electricity can pass through it, we call it an electrical conductor. Scientists think of electricity as being composed of large numbers of infinite divisions which have been termed "electrons." An electron is quite a small value when compared with the amounts of electricity we deal with in every-

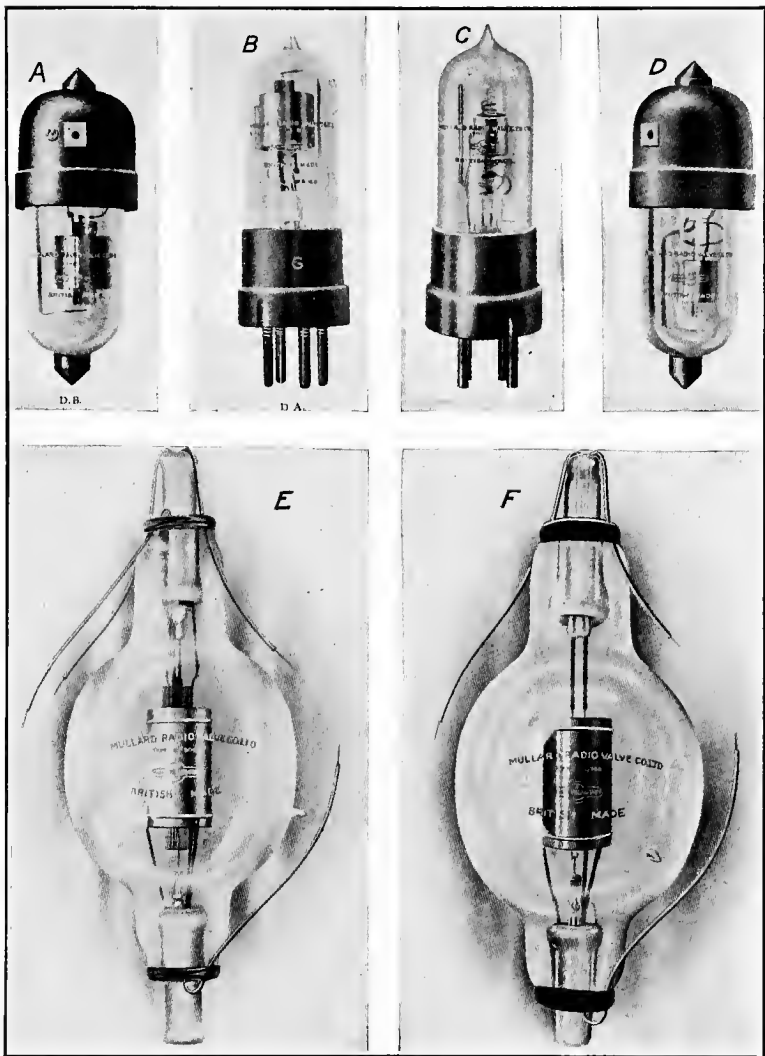

Vacuum tubes of English manufacture. *A* and *B* are "soft" detector tubes, *C* and *D* are hard amplifier tubes. *E* is a 500-watt transmitting tube and *F* is a 500-watt rectifying tube. The special construction of *E* and *F* allows the filament to be replaced without destroying the whole tube.

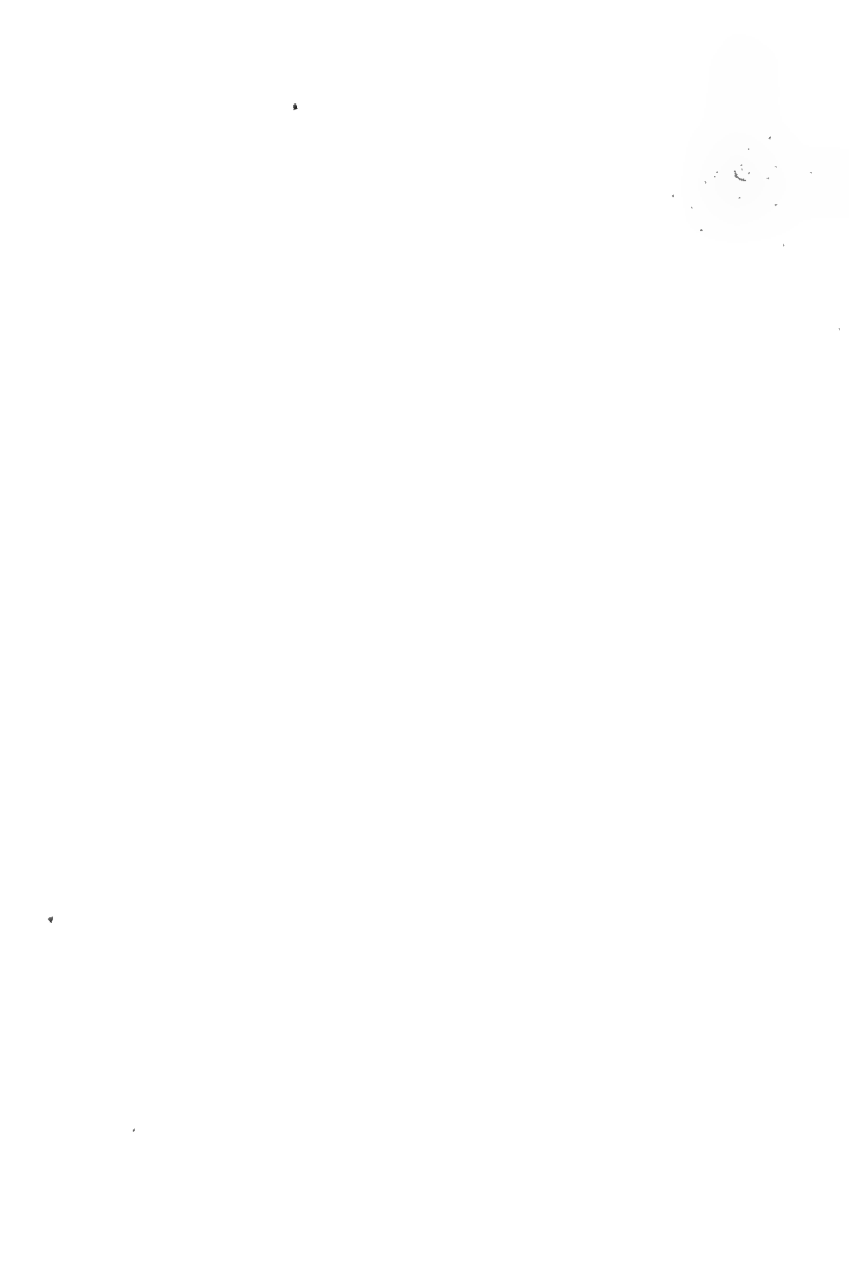

day life; for example, in order to light an average-sized incandescent lamp of fifty watts capacity it requires a stream of about 3,000,000,000,000,000 electrons per second.

When the molecular structure of any material prevents the passage of electrons more or less completely we rate this material as an electrical insulator.

When water is exposed to the air a certain amount of it vaporizes, and it evaporates as we say. The rapidity with which it evaporates is dependent upon several conditions, one of which is the temperature of the water. This is explained according to the "molecular motion" theory of heat by saying that some of the water molecules have attained sufficient speed due to the temperature to break through the surface and be shot off into the air. Water does not have to be in liquid form to evaporate; it is a well-known fact that ice will evaporate at temperatures considerably below the freezing point. This fact can be checked by hanging a wet cloth out on a very cold day; if conditions are right it will dry almost as rapidly as in the summer.

Other solid substances act in the same way as ice but usually require rather high temperatures before much evaporation takes place. One example is the gradual blackening of incandescent lamps which have been used for some time, the high temperature at which the filament is operated causes a certain amount of evaporation which condenses upon the cool walls of the glass bulb.

Tungsten is particularly suitable for lamp filaments because it can be heated very hot and give off large quantities of light without appreciable evaporation.

If high temperature produces extreme velocities of the molecules composing the material it is reasonable to suppose that it may also be true with regard to whatever electrons happen to be in the material. As the temperature is increased more and more some electrons will attain a sufficient

velocity to break through the surface of the material and be shot off into space. This idea of "evaporation" of electricity from heated bodies is further substantiated by the fact that the numerical relation between temperature and amount of evaporation are very much the same in the case of the actual evaporation of the material and "evaporation" of the electrons or thermionic emission, as it is usually called.

It has been found that the electricity given off from heated filaments, such as are used in electron tubes, is negative as compared with the commonly accepted idea of positive and negative electricity. Years ago the assumption was made that an electric current consisted of a motion of electricity from positive to negative. This was an arbitrary assumption made on account of a lack of information one way or the other, and it seems now that it was incorrect for we believe that the electron passes from negative to positive and has the same effect as a passage of so-called "positive" electricity in the opposite direction. Thus, according to the original assumption an electron is negative electricity and passes from negative to positive.

Fleming Valve.—The earliest application of the thermionic emission principle to radio telegraphy was in the Fleming valve used as a rectifier in radio receiving circuits. The apparatus consisted of an incandescent lamp filament mounted together with another electrode in the form of a plate inside a glass bulb and exhausted in the usual manner. When the filament is brought up to incandescence large numbers of electrons are shot off. As each electron carries a negative charge, the removal of electrons or negative electricity imparts a corresponding positive charge to the filament, the removal of negative electricity having the same effect as the addition of positive electricity. Unlike polarities attract and like polarities repel, so the positive filament will attract back all the electrons unless some other elec-

trical force is acting upon them. However, if the plate is charged positively by connecting it to a battery, a certain number of the electrons will be attracted over to the plate.

This action takes place only when the plate is positively charged with respect to the filament; if the connections to the battery be reversed then the plate will be negative with respect to the filament and repel the electrons back into the filament even more vigorously. Thus current will flow when the plate is positive but not when the plate is negative. If an alternating voltage is applied between plate and filament, electrons will pass and a current flow when the plate is positive but no action takes place when the plate is negative. The tube acts essentially like an electrical check valve, allowing current to pass in one direction but shutting it out absolutely in the other. Just how this rectifier action is utilized in the receiving circuit will be discussed in a later chapter.

Space Charge.—When applying comparatively low positive voltages on the plate we find experimentally that the current obtained represents only a fraction of the current corresponding to the number of electrons emitted from the filament. Thus some of the electrons sent off from the filament must have been attracted back into the filament even though the plate is charged positively. This action is attributed to what is generally known as “space charge.” Each electron carries a negative charge, similar charges repel each other, hence there is always a mutual repulsion between electrons. After an electron has left the filament there are two forces acting upon it, one the force of attraction of the positively charged plate and the other a force of repulsion due to the electrons which have left the filament ahead of it and which on account of the repulsive action between similarly charged bodies are pushing it back into the filament. Whether the electron leaves the surface of the filament or

not depends upon whether the force exerted by the plate or that due to the mutual repulsion action is the stronger. If the first predominates it will pass over to the plate, if not it will be repelled back into the filament. Each electron carries the same charge, hence two electrons at a given distance away will repel another electron with twice the force that a single electron would. Thus the repulsive effect on the electron just leaving the filament depends upon how many electrons are clustered around the filament in their motion toward the plate, in other words the electron density in the space just around the filament. The greater the density of electrons moving away from the filament the greater the current flowing to the plate, thus for any given positive plate voltage there will be a certain electron density around the filament which will just neutralize the pull of the plate. This prevents any increase in the rate at which electrons are pulled away for if more are pulled away the density around the filament will be increased and the electrons would be pushed back into the filament with more force than the plate exerts to pull them away. If the voltage on the plate is increased the current will increase to the point where the increased electron density around the filament is again sufficiently great to nearly balance the increased pull of the higher voltage on the plate. There is a limit to the number of electrons which can be drawn over to the plate, however, and this is determined by the total number of electrons emitted by the filament which in turn is controlled by the filament temperature. The current corresponding to a complete utilization of all the electrons sent off by the filament is generally spoken of as the "saturation current."

Fig. 6 shows how the current flowing to the plate varies as the filament current is maintained at a constant value and the plate voltage varied. The saturation current is indi-

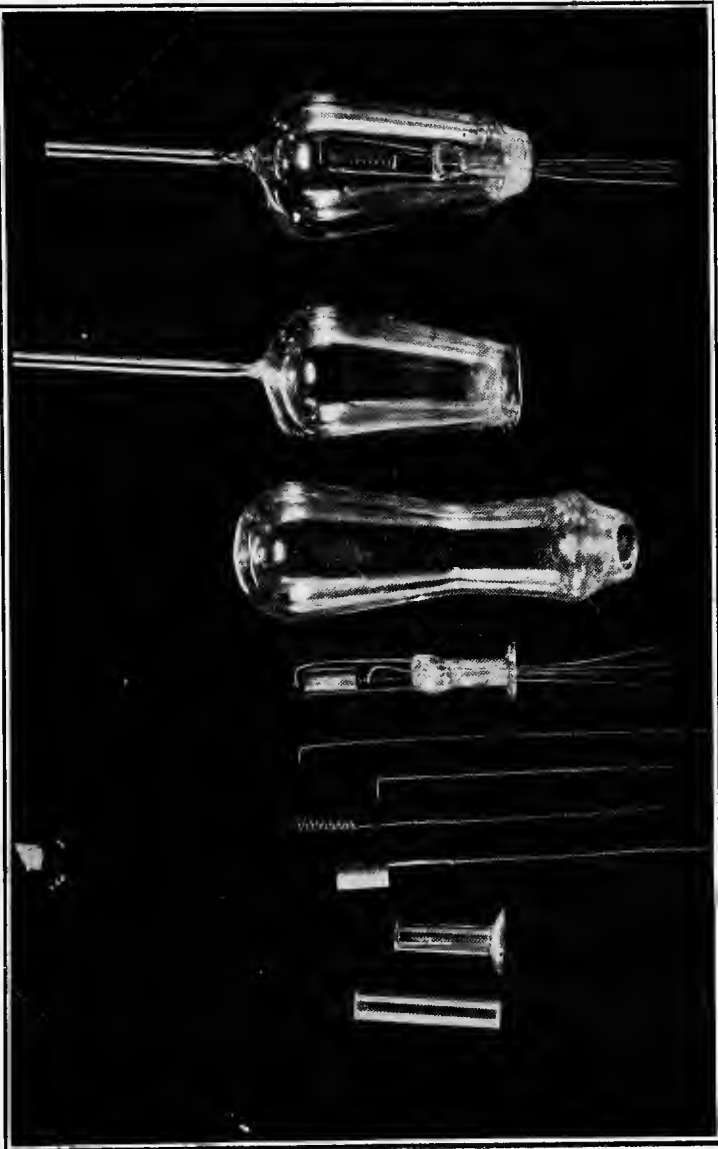

Steps in the manufacture of receiving tubes. A flange is spun on the end of the short piece of glass tubing and the plate, grid, and filament leads are sealed into the other end. The next two views show how the bulb is received from the factory is fitted with an exhausting stem and the end cut off. The last view shows the tube ready for exhaustion.

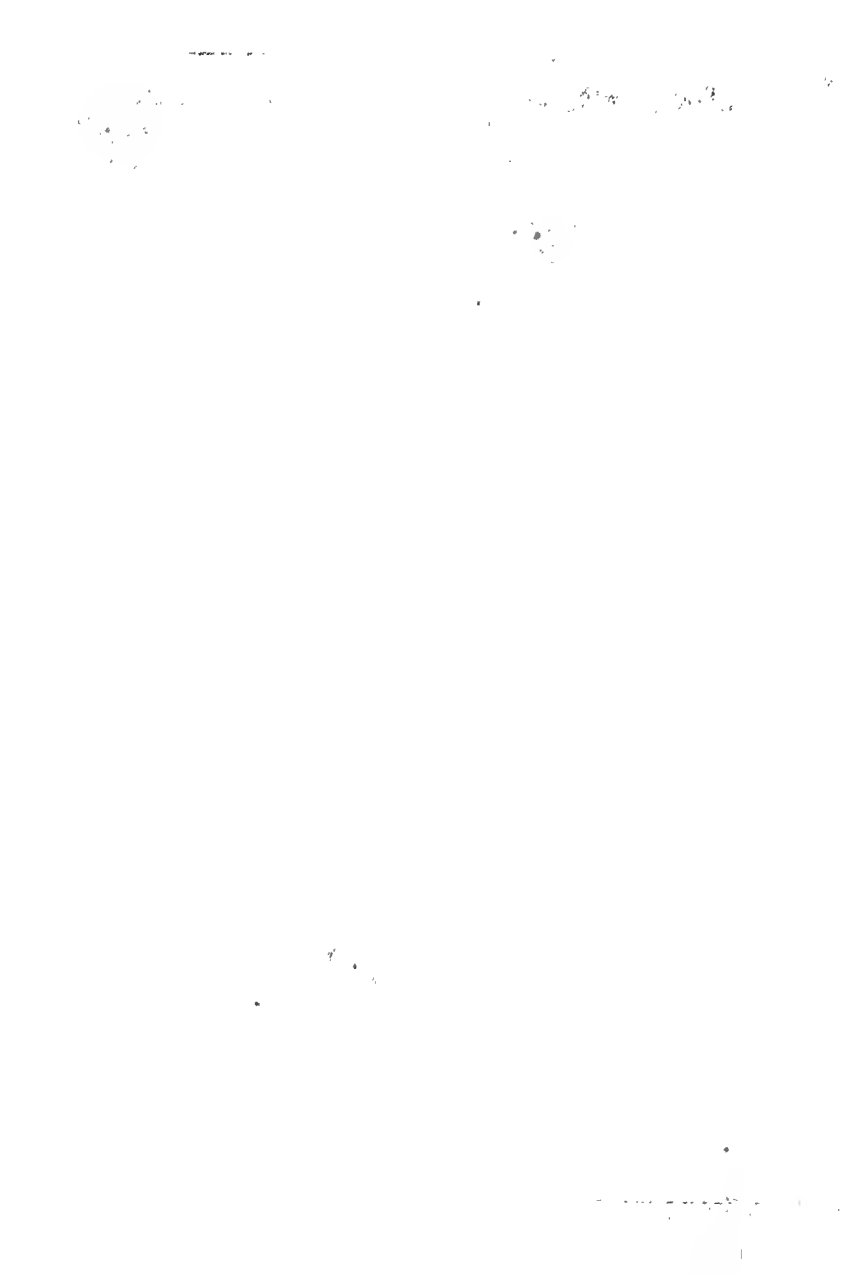

icated by the sudden flattening out of the curve. This indicates that all the electrons sent off from the filament are being utilized and hence the number cannot be increased by increasing the plate voltage.

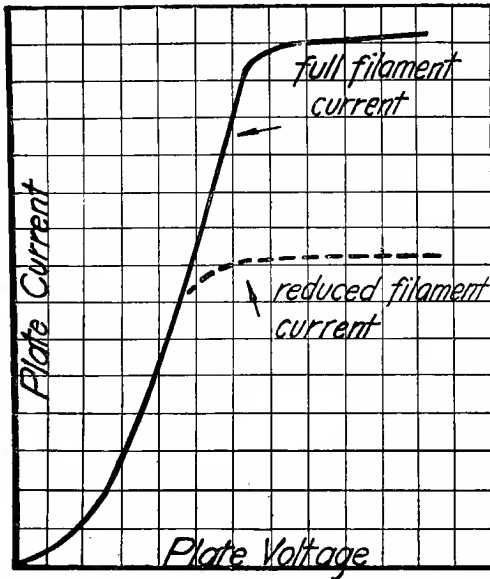

FIG. 6.—Curve showing the relation between plate current and plate voltage. The dotted curve shows the effect of not having the filament hot enough.

Grid Electrode.—The addition of the third electrode to the rectifying valve is due to Dr. Lee DeForest, who first investigated the action of the grid electrode. DeForest's three-element tube was of the same construction as the Fleming valve except that it contained a third electrode operating cold and located between the filament and plate.

The third electrode enormously enhances the value of the vacuum valve and increases its functions from that of simple rectifier to amplifier, amplifying rectifier, oscillator and modulator.

In considering the action of the third electrode, the grid acts merely in the capacity of a second plate in so far as the

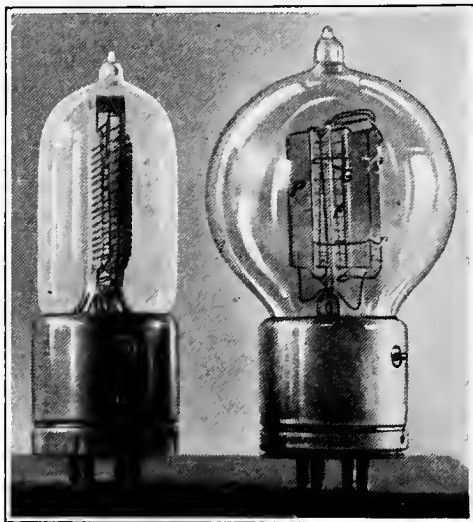

FIG. 7.—Three-electrode vacuum tubes. Receiving tube on the left and 5-watt transmitting tube on the right. The location of the plate, grid and filament is indicated by the letters *P*, *G* and *F*.

electric field around the filament is concerned. The space charge limitation of current is no longer determined solely by the potential of the plate but is the result of the combination of the potentials of both plate and grid. When the grid is located between the filament and plate it usually has a much greater relative effect on the limitation of the electron current

by space charge than does the plate. In other words the grid acts like a second plate located in a very much more advantageous position. In some large-sized tubes used for power purposes this ratio of effectiveness runs as high as 400, although usually much less. This means that if a given decrease in plate current required the reduction of the plate voltage from 800 volts to 400, the same effect could have been produced by lowering the potential of the grid by one volt. This ratio of effectiveness of grid and plate is usually spoken of as the "amplification constant." Grids are usually made in the form of a wire network; sometimes wound in the form of a helical spring with the filament in the center and with plates of cylindrical form outside, sometimes built in the form of a flat gridiron with fine wires closely spaced for use with flat plates. The amplification constant may be increased by placing the grid closer to the filament or by decreasing the opening between grid wires, but a tube with very fine grid and high amplification constant gives a relatively smaller plate current for a given plate voltage since the shielding action of the grid makes the plate voltage relatively less effective in drawing the electrons across.

Tungsten and Coated Filaments.—Most elements require an extremely high temperature before they give appreciable electron emission, hence only a few with very high melting points can be used practically. Tungsten with its extremely high melting point is very satisfactory where large electron currents are required and is used extensively for both transmitting and receiving tubes.

It has been found that numerous chemical compounds exhibit the same thermionic effects as pure metals and in certain cases at very much lower temperatures. The oxides of barium, strontium and calcium are particularly valuable in this respect and can be operated at a fairly low red heat as compared to the brilliant white heat required for tungsten.

Since the power input to the filament is used very largely to produce heat in the filament and the heat produced in the filament is necessarily a total loss, emission at low temperatures represents quite a saving of filament power. The usual procedure is to coat a platinum wire or strip with

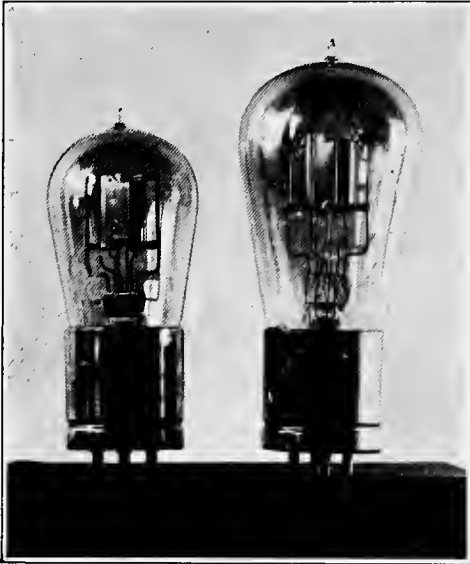

FIG. 8.—Receiving tube (left) and 5-watt transmitting tube (right).

certain compounds of the three metals which change into the oxide when heated. The author has built a number of tubes using other materials in place of platinum with very good success. The saving in power for a given filament emission is around 75 per cent as compared with the tungsten filament and makes it almost imperative to use coated

filaments in tubes designed to be operated from dry cells.

The tubes shown in Fig. 7 have oxide-coated platinum filaments and those illustrated in Fig. 8 have uncoated tungsten filaments.

CHAPTER IV

VACUUM TUBE OSCILLATORS

The ability of the three-electrode tube to produce alternating currents of radio frequencies makes it almost indispensable in radio communication and it finds application in both receiving and transmitting circuits.

The production of alternating currents depends upon the fundamental control which the grid has upon the plate current. This effect has already been touched upon in the previous chapter where it was pointed out that the plate current was increased or decreased as the grid voltage was made more positive or more negative with respect to the filament. The grid really acts like an electric control valve and allows more or less energy to flow from the plate battery, and since under proper conditions, the grid valve can be made nearly "frictionless," electrically speaking, a very small amount of energy applied to the grid may control a large output from the plate battery. Thus it can be seen that this device should have a distinct application in amplifying weak voltages.

There are a number of mechanical illustrations of amplifier action, for instance, the tremendous blow of the steam hammer can be controlled by an easily operated valve in the hands of the operator. The operator presses down on the control valve with a force of say five pounds and this action controls the hammer so that it strikes a blow of five tons on the anvil. Then he may operate the valve in the other direc-

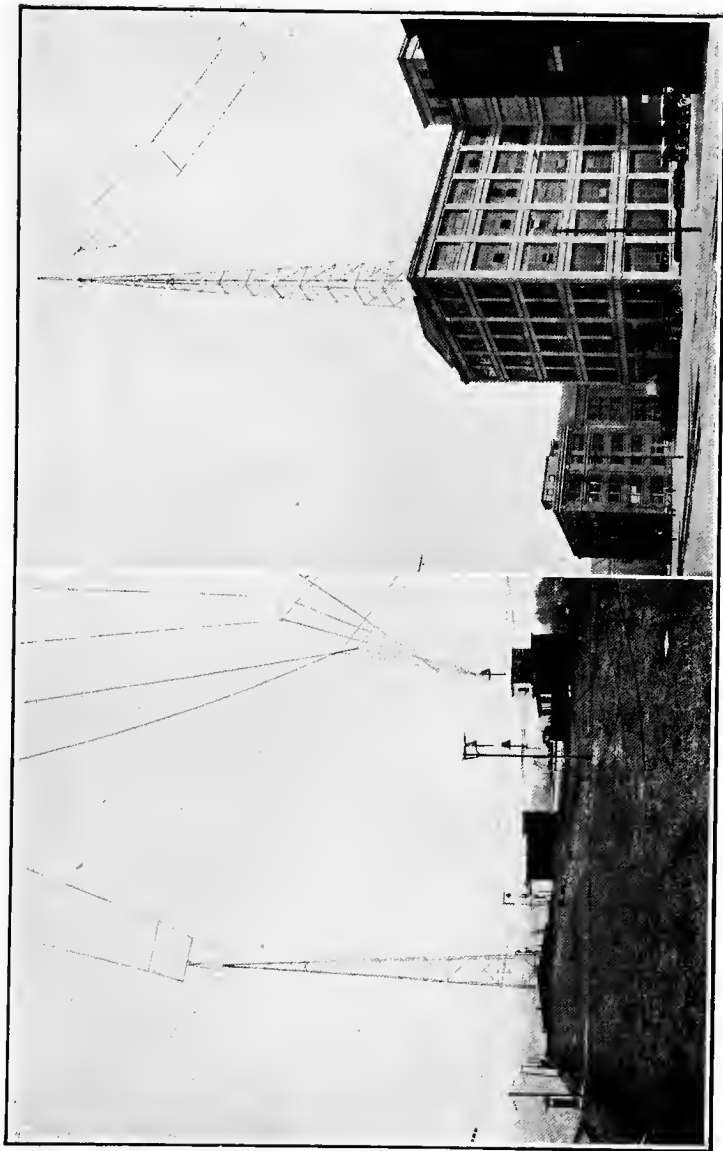

Two views of the antenna system used with the transmitter shown in frontispiece. The short poles near the edge of the roof support the counterpoise.



tion with another five-pound force applied upwards and release the five-ton pressure on the anvil. If we are to consider this action in the same sense of amplifier as applied to the vacuum tube; we would say that the five-pound "blow" of the operator had been amplified into a five-ton blow on the anvil. In other words, by controlling the power supplied from the boiler, we have "amplified" the operator's strength two thousand times. In the case of the tube, the grid acts like the steam valve which allows more or less of the boiler pressure (corresponding to the voltage of the plate battery) to act. It is distinctly not a device from which something can be obtained for nothing, but acts merely as a control of some secondary source of energy.

If it were desirable, we could make the steam hammer self-acting and have it continue to move up and down automatically by a simple arrangement which would open or close the valve as the hammer reached the end of its stroke. A possible scheme of this character is shown in Fig. 9. The sliding valve shown in black moves up and down on its seat. When it is in its upper position it uncovers the opening from the boiler and allows steam to pass into the lower end of the cylinder, where it acts on the lower side of the piston and pushes it upwards. When the valve is in the lower position, the steam from the boiler is cut off, and a passage from the cylinder to the open air is provided, thus allowing the hammer to descend from its own weight. In order to make it self-acting, a rod, pivoted at the center, and connected to the lower end of the valve rod is so arranged that it is moved when the hammer reaches either end of its stroke. When the hammer hits the bottom the valve rod is moved upwards and the hammer started on its upstroke; when it reaches the top, its motion is reversed and the hammer falls. This action will continue until the steam is shut off at the boiler.

One important requirement for continued operation is

that the force which the hammer exerts must be more than that necessary to open and close the valve; in other words, we

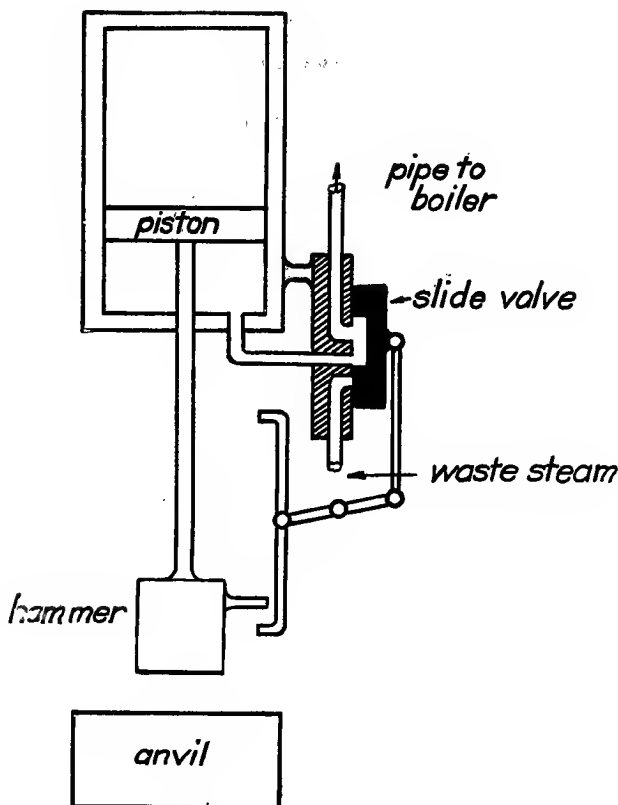

FIG. 9.—Steam hammer with automatically operated control valve.

must have the element of “amplification” present or the apparatus will obviously not operate. This general fact is true in the operation of any self-controlled system of this

kind. For instance, if the sound produced by a telephone receiver is of greater intensity than that which must be impressed on the transmitter to produce the same sound, the system can be made to oscillate and produce a loud "howl" by placing the receiver near the transmitter. Here again we have taken a portion of the power from the controlled circuit and put enough back into the controlling circuit to maintain the oscillation.

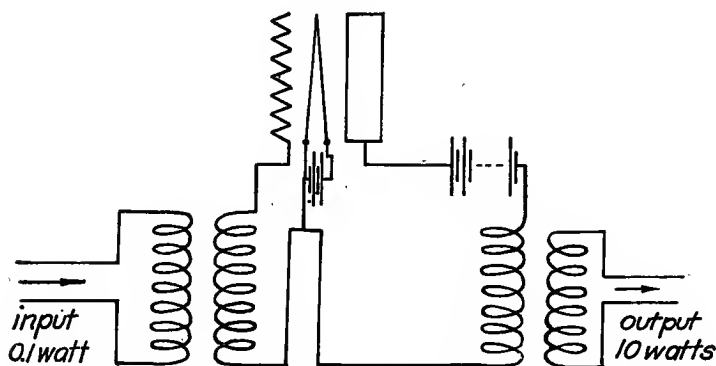

FIG. 10.—Vacuum tube with its grid excited from an outside power source.

Feedback Coupling.—In applying these principles to the vacuum tube, we must take some of the energy set free from the plate battery and bring it back to the grid circuit where it can in turn control the output of the plate battery.

Consider Fig. 10 in which a vacuum tube is shown with its grid circuit connected to an outside source of power. Assume that it takes $\frac{1}{10}$ watt input to completely control the output of the plate battery, and that under these conditions the plate battery can deliver 10 watts of power. If the grid

circuit is connected to a 60-cycle source of power, the power output of the plate circuit will be a reproduction of the impressed 60-cycle wave. But it is possible to take $\frac{1}{10}$ watt of power from the plate circuit and still have a possible 9.9 watts of power left. Under these conditions the system could be made to oscillate without any connection to an outside source by taking $\frac{1}{10}$ watt from the plate circuit and impressing it upon the grid.

Frequency of Oscillation.—When the tube connections are changed from outside excitation to self-excitation by coupling the grid circuit over on to the plate circuit, the frequency at which power is being produced in the plate circuit will probably change from the original frequency of 60 cycles. When the input frequency is controlled by some outside source of power, the tube has no choice but to reproduce in the plate circuit what has been impressed on the grid circuit, but when the tube is self-excited by coupling plate and grid circuits together, the frequency impressed on the grid is the same as that produced in the plate circuit. This in turn is controlled by the grid action alone, and thus a change in one circuit produces a complete change in the other. The actual outcome is that after a very short period of time, the tube will pick out the frequency at which it can most easily oscillate and continue to operate at that particular frequency. This frequency will be determined by the electrical constants of the circuit, and is analogous to the natural frequencies that mechanically vibrating bodies have. A swing will swing back and forth very easily at one particular speed, but if an attempt is made to speed it up or slow it down, it will require considerable exertion. These critical speeds or frequencies are generally spoken of as “resonant” or “natural” frequencies.

Types of Feedback Coupling.—There are a number of different ways in which a portion of the energy from the

plate circuit may be fed back into the grid circuit. Fig. 11 shows a method in which the changes in the plate current react directly on the grid circuit through a transformer. As the plate current in coil L_p increases and decreases it sets up alternating voltages in L_g , the coil connected to the grid circuit, and thus sustains the oscillations in the plate circuit. This type of circuit should be classed under the head of magnetically coupled circuits.

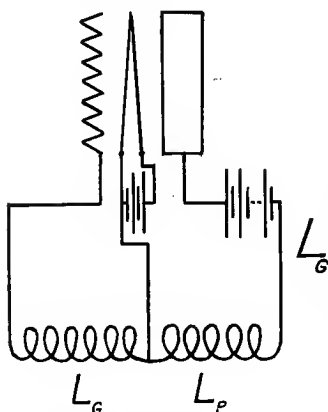

FIG. 11.—Magnetically coupled feedback circuit.

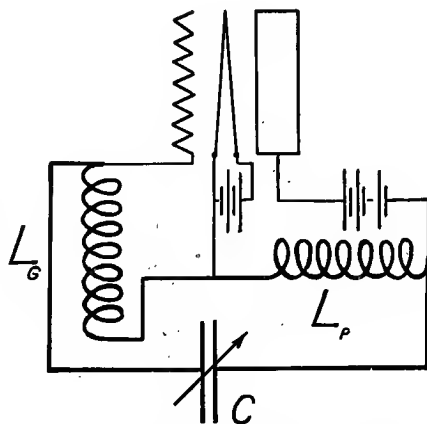

FIG. 12.—Another type of feedback circuit.

Another scheme is illustrated in Fig. 12. Here the coil carrying the plate current and the grid coil have no magnetic relation to one another but are merely connected in the same electrical circuit. When a pulsating current flows in the plate circuit, it sets up an alternating voltage in the plate coil L_p . The plate coil being a part of the heavy lined oscillatory circuit, sets up a current in this circuit, which in turn sets up a voltage across the grid coil L_g . Thus the

same effect is produced as in the case of the direct magnetic coupling just described.

The third system illustrated in Fig. 13 is essentially the same as far as theoretical relations are concerned except

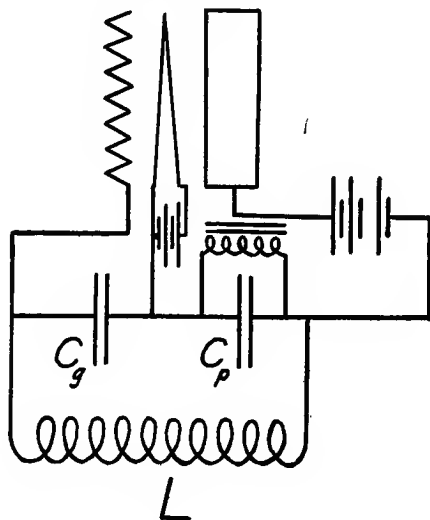

FIG. 13.—Circuit similar to Fig. 12 using condensers in place of the inductance coils.

that condensers are used in place of coils with essentially the same results.

Electrostatic coupling is illustrated in Fig. 14. Here the coupling is due to the fact that the condenser C_1 is located in the part of the circuit common to both grid and plate circuits. The alternating component of the plate circuit passing through the condenser C_1 produces a voltage drop across C_1 . Since this drop is also in the grid circuit, its

effect is carried on to the grid and oscillations are thus sustained. The direct current component of the plate current cannot flow through the condenser so a bypath around the condenser must be provided. This bypass should allow the direct current to flow and shut out the alternating current

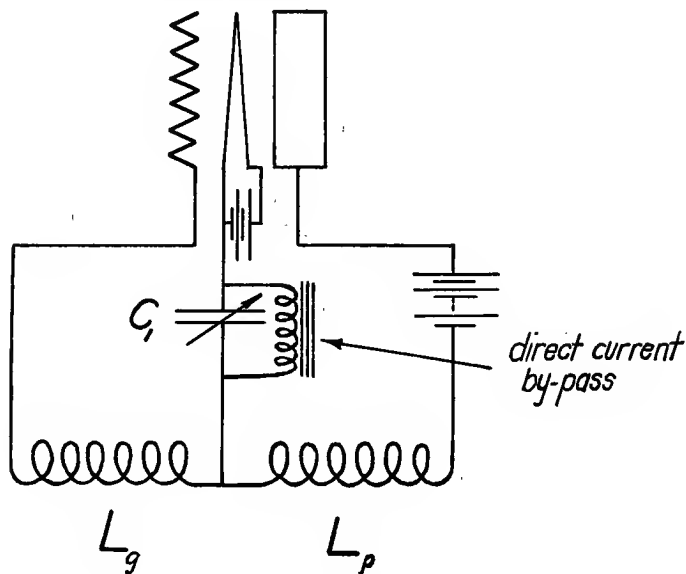

FIG. 14.—Electrostatically coupled feedback circuit.

so that it has to pass through the condenser. This function can be satisfactorily performed by an iron-cored inductance coil of comparatively low resistance and connected in parallel with the coupling condenser. Since the voltage drop in any condenser is proportional to the current and inversely proportional to the product of the frequency and the capacity of the condenser for a given high-frequency current in

the plate circuit, the voltage impressed in the grid circuit will be inversely proportional to the capacity of the condenser. Thus to increase the effective coupling between grid and plate circuits the condenser capacity should be reduced. Changing the capacity of the coupling condenser also changes conditions in the plate circuit so that the relations are somewhat complex.

There are a number of modifications and combinations of the above circuits applicable to practical operation, in fact most of the circuits in actual use employ two or more fundamental types of coupling simultaneously.

Frequency.—In predicting the frequency of oscillation in circuits similar to that given in Fig. 12, it is necessary to know the inductance of the coils L_g and L_p and the capacity of the condenser C . Where these values are known, we have the relation

$$f = \frac{300,000,000}{1884\sqrt{(L_p + L_g) \times C}}$$

where f is the frequency in cycles per second, L_g and L_p are the inductances of the respective coils expressed in microhenries and C the capacity of the condenser expressed in microfarads. If we wish to express the results in terms of wave length instead of frequency the following relation would be used:

$$\text{wave length in meters} = 1884\sqrt{(L_g + L_p) \times C}.$$

In generating very short waves where the capacity of the condenser C is very low, the internal capacity of the tube and tube socket must be taken into account. In one type of receiving circuit, formerly very popular with the amateurs, the only capacity employed was that of the tube and the

socket together with the capacity effects of the coils themselves, with the condenser C omitted entirely.

If there is any magnetic coupling between the two coils another term must be added to the above equations. The quantity in parenthesis will now be increased by $2M$, where M is the mutual inductance of the two coils.

The circuit shown in Fig. 13 can be solved in the same way if we substitute the equivalent capacity of the two condensers for the value of C as given in the equation. The expression for the equivalent value of two condensers connected in series is

$$C_{eq} = \frac{1}{\frac{1}{C_1} + \frac{1}{C_2}} = \frac{C_1 C_2}{C_1 + C_2}.$$

Plate-voltage Supply Systems.—The principal problem in the operation of power tubes is the high-voltage plate supply, and it may be solved in several different ways. The potential required varies with the size of the tube used. For standard small power tubes rated at 5-watts output, this value lies around 300 volts; for tubes of 50-watts output, it is 1000 volts; for 250 watts, it is 2000 volts; and up to 20,000 volts for higher powered tubes. Standard 2000-volt direct-current generators are now available but above this value it is usual to use a rectifier system in connection with an alternating-current supply, the resulting output being smoothed out with suitable electrical filters consisting of condensers and inductance coils.

Direct-current Generators.—The construction of direct-current generators up to 500 volts is so well known that only certain special types of machines will be considered here. One requirement of all plate-voltage generators is that the voltage should be as constant and as free from ripples as

possible. This requirement should be met by having as many commutator segments as possible since the disturbance caused by the brushes passing from one segment to the next may be thus reduced in the inverse proportion of the number of commutator segments. High-voltage generators usually require a large number of commutator segments for insulational purposes also. For sets which are to be supplied from storage batteries a special type of combination motor and generator has been developed. This machine,



FIG. 15.—Dynamotor for producing high-voltage direct current from a low-voltage direct-current supply.

which is known as a “dynamotor,” has a single field and armature, but two separate windings on the armature which are insulated from one another. Each of these windings is brought out to its own commutator, one of which is located on each end of the shaft. The low-voltage winding designed for a value around 10 or 12 volts is connected to the storage battery and acts as the motor, while the other winding produces a high potential of about 350 volts for the plate supply. The field winding is supplied from the storage battery. A similar piece of apparatus is sometimes used in

airplane sets, the machine in this case acts as a double-current generator driven mechanically by an air fan and supplies both plate and filament circuits simultaneously.

For voltages up to 1000 volts a single-commutator machine is usually employed, above this value, double-commutator machines are preferable. The standard 2000-volt generator

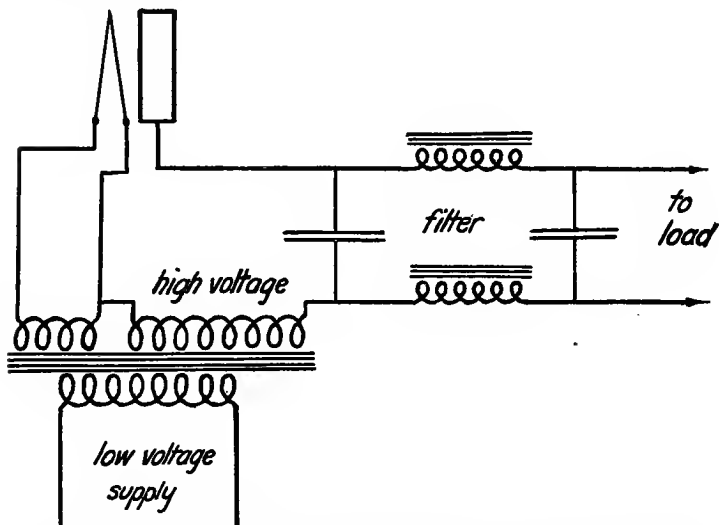

FIG. 16.—Rectifier connections in which but one-half of the alternating current wave is utilized.

built by one manufacturer has two 1000-volt windings brought out to separate commutators on each end of the shaft. The two windings are connected in series to produce 2000 volts. The field excitation on this machine is preferably arranged to be furnished from a separate low-voltage supply, thus keeping the field circuit entirely insulated from the high-voltage windings.

Rectifier Systems.—Rectifier systems are applicable from about 500 volts upwards. Although they may be used below 500 volts, the difficulties involved in smoothing out the wave usually make the generator preferable.

High-powered tubes require high-voltage and low-current supply, hence rectifiers utilizing pure electron emission are

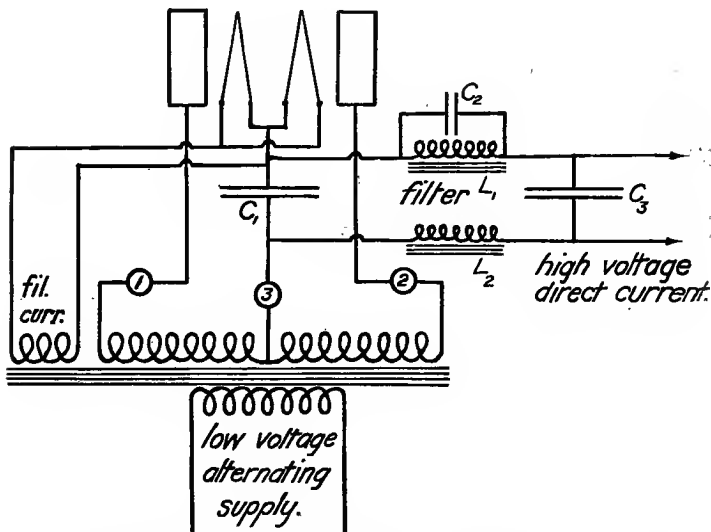

FIG. 17.—Rectifier utilizing both halves of the alternating current wave.

better suited than those of the mercury arc type. As commercially manufactured they much resemble the power tubes which they are designed to supply except that the grid being unnecessary is of course omitted. Fig. 16 shows the connections employed where one tube is used and only one-half of the wave rectified. Double-wave rectification employing two tubes and utilizing both halves of the wave is much to be preferred in the case of radio telephone trans-

mitters. The currents in the various portions of the circuit indicated in Fig. 17 are illustrated in Fig. 18. The condenser C_1 acts as an electrical storage reservoir for the energy which passes into it in impulses as delivered from the rectifier. The irregularities are further eliminated by the series inductance coils, L_1 and L_2 , which are composed

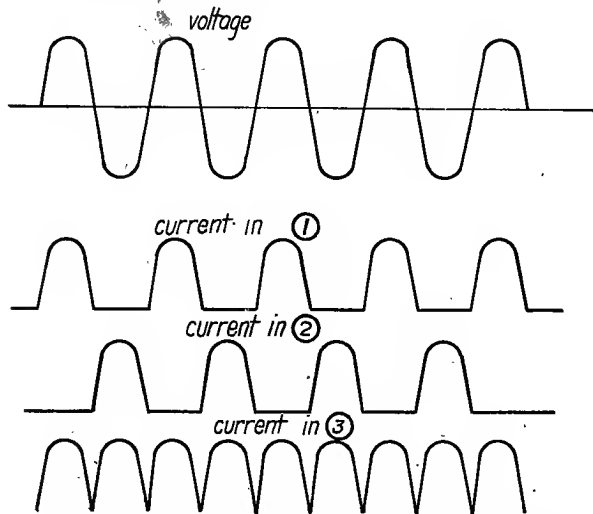

FIG. 18.—Voltage and rectified currents as indicated in Fig. 17.

of a very large number of turns wound on an iron core. The energy is transferred to the condenser C_3 which acts as another storage reservoir and serves to still further smooth out the variations. Coil L_1 is shunted by another condenser C_2 , and the two values are adjusted so that they are resonant together at the supply frequency. This, as can be mathematically shown, produces a very high resistance to the passage of currents of this particular frequency and is an

additional aid to the elimination of the low-frequency ripple. Since irregular waves are composed of a large number of multiple-frequency waves the single-frequency trap cannot

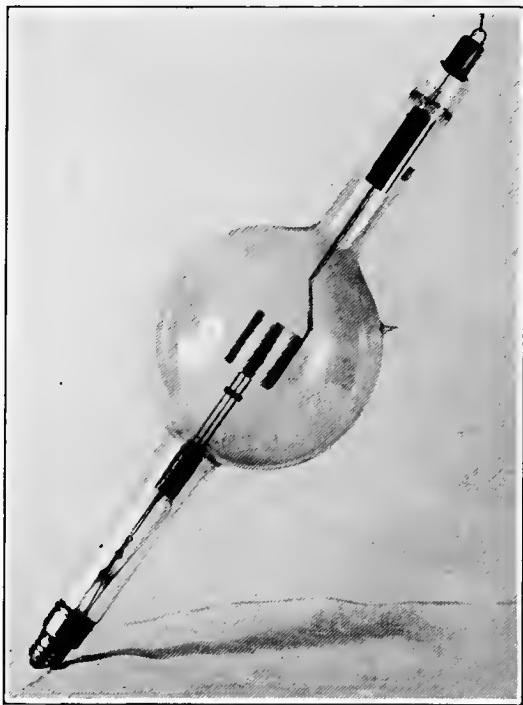

FIG. 19.—Hot cathode or "Kenotron" rectifier. Normal rating 0.1 ampere at 100,000 volts.

eliminate all of the disturbing variation. If it is desired to smooth out the wave still further, other sections of series inductance and shunt capacity may be added with increasingly better results. With properly designed filter systems

direct-current voltages may be produced which compare very favorably with those produced by direct-current generators, and which are very well suited for radio telephony.

Cold-cathode Rectifiers.—A cold-cathode rectifier has recently been developed by one manufacturer. This apparatus consists of two electrodes mounted inside a glass bulb in a much-reduced atmosphere of certain gases. Its operation hinges on the peculiar effects of ionization by collision as experienced in the action of soft detector tubes under which heading this action is treated in some detail. The electrodes are so arranged that all electrons passing from one of the electrodes to the other are absorbed before any ionization by collision with the gas particles can be effected while electrons passing in the other direction have a long enough path so that they can produce new electrons and positive ions by collision. The result is that when potential is applied in one direction a very minute current consisting of the free electrons in the gas will flow, but on reversing the direction of the voltage the current will be very much increased due to the additional electrons and positive ions set free by collision. The rectification is not perfect since some current will flow in either direction but the reversed current is very small and almost negligible.

The connections used in its operation are exactly the same as those shown for the hot-cathode rectifier except that the circuit used for lighting the filament is not needed.

Electrolytic Rectifiers.—On account of the extreme simplicity of construction the electrolytic rectifier is quite well suited for the rectification of small amounts of alternating-current power at moderate voltages. It consists of active plates of aluminum and inactive plates of carbon or lead immersed in electrolyte. There are a number of different solutions which can be used but a saturated water solution of pure boracic acid seems to be a favorite. The voltage

that each cell will take care of is dependent upon the construction but usually does not exceed 200 volts, hence a number of cells must be connected in series where voltages above this value are used. The connections used are



FIG. 20.—Cold cathode rectifier and electrolytic condenser.

exactly similar to those shown for use with hot-cathode rectifiers with the vacuum tubes replaced by the proper number of cells connected in series. The filament circuit is of course not needed. Obviously either single- or double-wave rectification may be obtained by the proper connection.

Proper operation is indicated by a series of star-like sparks at the surface of the aluminum electrode and care should be taken to provide sufficient capacity so that the electrolyte does not become very hot as rectification may be partially or totally prevented by high temperature.

Filter Condensers.—Filter condensers must have high capacity and be able to withstand the full-plate voltage. These conditions are best fulfilled by mica or treated paper condensers since air condensers are very bulky in large capacities. Ordinary paraffined paper telephone condensers are suitable if the plate voltage does not exceed 300 volts, but where voltages go much above this value mica or specially treated paper condensers should be used. It is not safe to connect two or more condensers in series across a high-voltage direct-current supply as the voltage will divide between the various units in direct proportion to their individual insulation resistances. Thus if two condensers are used in series and one is slightly "leaky" the full voltage will be thrown across the good one and will usually puncture it. It is possible to equalize the voltages in such cases by connecting equal resistances across each condenser, but this is wasteful of energy.

Filter condensers are usually not designed to carry radio-frequency currents since large losses are induced by the high-frequency which heats the condenser internally and eventually destroys its insulation. Where there is any possibility of this happening a radio-frequency choke and by-pass condenser capable of handling radio-frequency current must be provided. The by-pass condenser need not be very large but must be capable of standing up under the full plate voltage. Its capacity need not be more than .001 mf. for short waves. The radio-frequency choke will vary in size depending upon the wave length used. For amateur waves around 200 meters a coil consisting of from 100 to 200 turns

of wire wound on a tube about $2\frac{1}{2}$ inches in diameter in a single layer is sufficient. The location of the choke should be between the last filter condenser and the oscillator tube and the by-pass condenser should be located on the oscillator side of the choke.

Electrolytic Condensers.—Electrolytic condensers are formed by immersing aluminum electrodes in certain solutions and passing a direct current between them. The action of the electric current is to decompose some of the electrolyte into gas and form a thin film of gas between the surface of the plate and the electrolyte. Since the gas film is extremely thin the capacity per unit area is very high and large capacity condensers can be easily constructed by providing fairly large electrode surface. The breakdown voltage of this type of condenser depends upon the electrolyte used, one authority gives 480 volts for sodium borate, 470 volts for ammonium citrate, 460 volts for ammonium acid phosphate and 445 volts for sodium silicate. One advantage of this type of condenser is that it is self-healing; if it is punctured, reduce the voltage and build up a new gas film and it will function as well as ever.

The electrolytic condenser illustrated has special aluminum electrodes designed to give very large area in contact with the electrolyte and has very high capacity. The capacity is so high that in certain cases the filter inductance may be greatly decreased in size or entirely omitted with very satisfactory results.

Radio-frequency Power Amplifiers.—On account of the very sharp tuning possible with tube transmitters it is very important that the transmitted frequency be maintained very nearly constant. In circuits where the tube supplies its own excitation by coupling back from the plate circuit, any change in the constants of the plate circuit or circuits associated with the plate circuit will have a corresponding

effect on the frequency of oscillation. Since in most circuits the antenna is either directly or inductively coupled to the plate circuit, any change in the antenna inductance or capacity will react back upon the plate circuit and produce a very annoying change in frequency. Unless the antenna is very well guyed, it will swing in the wind, and this motion will change its effective capacity. This will in turn produce

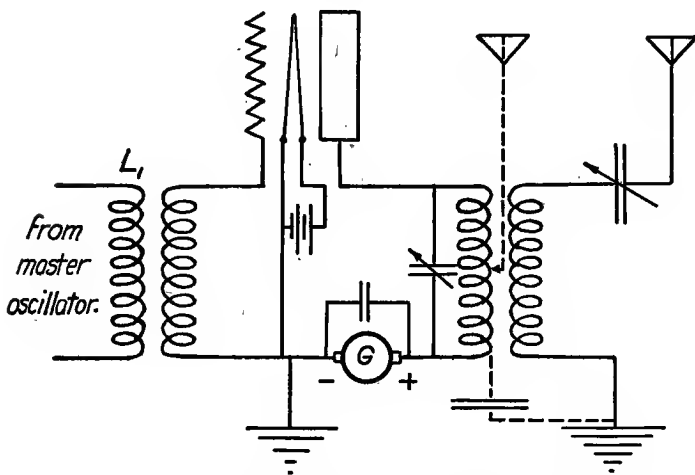

FIG. 21.—Master oscillator and radio frequency power amplifier.

a change in the transmitted wave length. To eliminate this difficulty, the circuit shown in Fig. 21 has been devised. The coil L_1 is connected to the output circuit of the master oscillator tube which for radio telephony would be arranged for modulation by some one of the modulation systems outlined elsewhere. The output of the master oscillator is impressed on the grid of the power amplifier tube and is in turn amplified and put into the antenna circuit. Since

there is no connection between the antenna and the master oscillator tube except back through the amplifier which only operates in one direction, a variation in the antenna constants will not affect the frequency of oscillation. The power rating of the master oscillator may be very much lower than the amplifier, or one master oscillator tube may control several tubes of the same type connected together as amplifiers. The grids, filaments and plates of the several amplifiers would be respectively connected together and should operate satisfactorily if their construction is uniform.

Transmitting Tube Circuits.—For the sake of simplicity the plate-voltage supply has been shown in nearly all diagrams as connected next to the plate in the plate circuit. While this is satisfactory in the case of receiving tubes it is not desirable in the case of power tubes as it puts the generator or rectifier system in a high potential part of the circuit as far as radio-frequency voltage is concerned. This may induce considerable strain between the windings and the ground and may puncture the insulation. In order to avoid this condition the proper position for the generator or rectifier system is next to the filament circuit with the negative side connected directly to the filament. If the filament is supplied with alternating current this connection should be made to the center tap on the filament winding. This common point is usually grounded to guard against the possibility of any considerable potential being set up between generator windings and frame. These precautions have been indicated in Fig. 21.

In nearly all circuits shown the plate-voltage supply has been connected in series with the plate coil. It may also be connected in parallel with the plate coil if a condenser is inserted in series with the plate coil to prevent it short-circuiting the plate-voltage supply. In order to prevent the high-frequency current from passing through the generator

rather than through the plate coil the by-pass condenser across the generator terminals should be omitted and a radio-frequency choke inserted in one or both leads.

There are two general types of possible connection with the antenna circuit, inductive and direct.

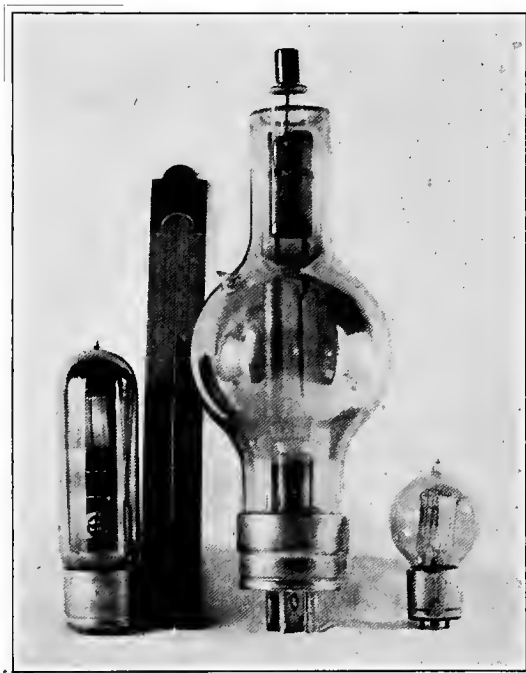

FIG. 22.—Power tubes rated at 50, 250, and 5 watts output respectively.

Inductive coupling is illustrated in Fig. 21 by the solid lined antenna circuit. This system offers advantages where the antenna system is of high resistance or where very short wave-length transmission is desired.

Direct coupling is obtained by completing the antenna circuit through several turns of the plate coil. This type of connection is illustrated in Fig. 21 by the dotted antenna circuit. The number of turns used should be adjustable to compensate for different antenna and tube characteristics. The condenser in the ground lead is necessary to prevent the plate-voltage generator being short-circuited through the double-ground connection. With a high-resistance antenna and direct coupling it is sometimes difficult to make the tube oscillate properly on account of the large resistance effect of the antenna. In such cases it is advisable to employ inductive coupling as the adjustments are somewhat simpler.

CHAPTER V

MODULATOR SYSTEMS

The modulator in radio transmission has the same duty as the transmitter does in wire transmission. If the transmitter does not alter its resistance the value of the direct current flowing through the circuit will remain unchanged and the telephone receiver diaphragm will not vibrate; only when the current is changing in value is any sound transmitted and the modulator in radio telephony is the device that varies the output of the set in accordance with the sound wave that it is desired to transmit.

There are two general schemes which are employed in radio telephony, in the first one the tube delivers a constant power output and the transmitted wave is varied in amplitude by changing conditions in the antenna circuit; the second one does not vary antenna conditions but controls the output of the tube in accordance with the sound wave to be transmitted.

Modulation by Antenna Control.—The simplest case of modulation by antenna control is illustrated in the use of an ordinary telephone transmitter or microphone connected directly in the antenna circuit. The telephone transmitter, as has been pointed out, is a device which changes its resistance to correspond with the sound waves impressed upon its diaphragm, hence the transmitter connected directly in series with the antenna will cause the current to rise and fall as the resistance decreases and increases. The one serious

limitation which this system involves is the small amount of power which can be successfully handled by its use. Where the antenna current is only a small fraction of an ampere, the ordinary telephone transmitter will act satisfactorily, and where larger currents are involved special high-current microphones have been developed, but the system as a whole is wasteful of power and not satisfactory.

Magnetic Modulator.—Another more satisfactory solution involves the use of the magnetic modulator. A schematic drawing of the magnetic modulator is shown in Fig. 23. The iron core is composed of a strip of very thin transformer iron wound into the form of a hollow cylinder. The direct-current winding, which is wound through the center of the cylinder, is connected in series with a battery and telephone transmitter. The high-frequency current winding is placed around the outside of the cylinder at right angles to the direct-current winding. For short waves this winding is wound in two parts and connected in series, the two halves being wound in opposite directions. The high-frequency conductor is composed of a number of fine insulated copper wires braided together, commonly called "litzendraht." This type of wire has a much lower resistance at high frequencies than solid wire. The iron core is of special thin high-frequency iron and carefully insulated.

The action of this type of modulator is difficult to explain without recourse to rather advanced mathematics, briefly the action depends upon the effect that varying magnetic saturation has upon the modulator. When the direct current from the microphone is large the iron becomes nearly saturated, that is, it will only slightly respond to further increases in current. This changes the characteristics of the high-frequency coil also and hence the current in the antenna. This effect is varied to a greater or less degree depending upon the value of current flowing through the

direct-current winding, which is in turn controlled by the resistance of the microphone, and thus the sound waves are reproduced in the amplitude of the antenna current.

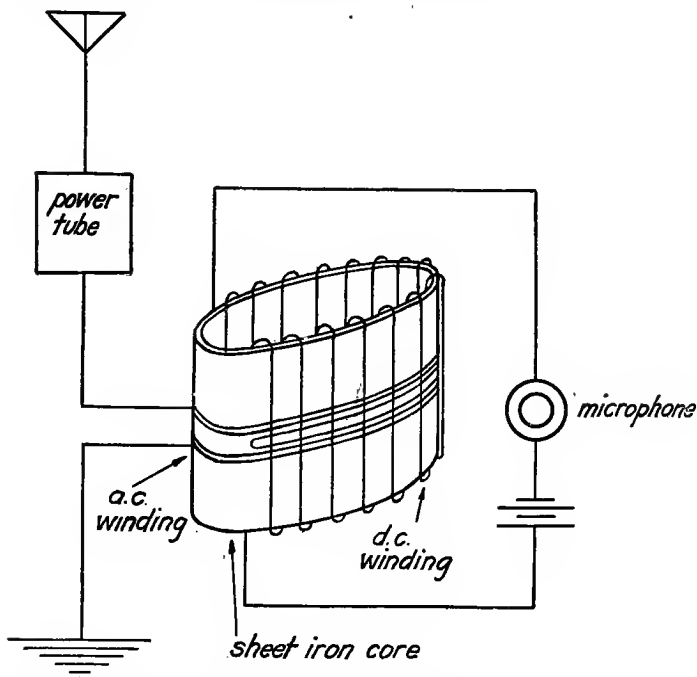

FIG. 23.—Magnetic modulator showing connections to power tube oscillator and antenna.

The current-carrying capacity of this apparatus is not limited as was the case with the microphone and it can be employed to modulate very large outputs. For simplicity of operation it can hardly be improved upon, and the results obtained with its use are very satisfactory.

Modulation by Variation of Tube Output.—This system differs from the one just described in that the constants of the antenna circuit remain unchanged and the output of the tube oscillator is made to vary in accordance with the sound wave to be transmitted. There are two general ways in which the output of the tube oscillator may be varied: (a) by

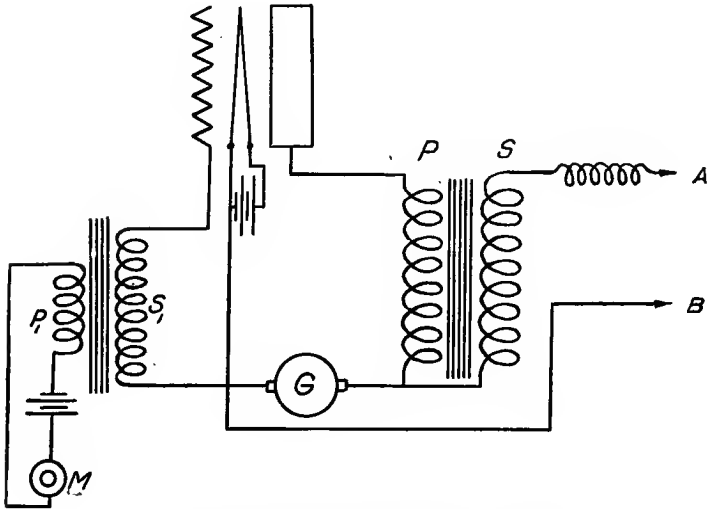

FIG. 24.—Plate circuit modulator connections.

variation of the plate voltage and (b) by variation of the grid voltage.

Plate-circuit Modulation.—Connections for plate-circuit modulation are shown in Fig. 24. The terminals *A* and *B* are connected to a tube oscillator in place of the usual high-voltage supply connections. *P* and *S* are two coils of an iron-cored transformer, the plate current to the oscillator tube flowing through *S*, and the plate current of the modu-

lator tube flowing through P . If the plate current from the modulator tube remains constant no voltage will be induced in the coil S , and the voltage applied at the plate of the oscillator tube will be that generated by the direct-current generator G . Any variation in the current flowing through P will set up a voltage in coil S , and since this coil is in series with the plate of the oscillator tube, the actual voltage delivered to the oscillator tube will be the sum of the voltage produced by the generator and that set up in the coil S due to the change of current in coil P . Sometimes this voltage will be in such a direction as to add to the voltage supplied by the direct-current generator and at other times it will oppose the generator voltage and lower its effective value. The output of the oscillator is thus changed, its value being low when the applied voltage is low and large when the applied voltage is high.

When sound waves impinge upon the diaphragm of the microphone M , its resistance is changed and the current flowing through the primary coil P_1 of the modulation transformer is changed in accordance with the resistance variation. This sets a voltage up in the secondary coil S_1 which in turn is transmitted to the grid of the modulator tube. Variation of the grid voltage varies the plate current, and finally changes the voltage applied to the plate of the oscillator tube thus changing its output.

It is not necessary to use two separate coils P and S , as both plate currents may be carried through a single coil. This corresponds to the "auto-transformer" connection well known in electrical work and is essentially the same as far as electrical characteristics are concerned as the two-coil transformer with equal number of turns. The connection employing the single coil has been erroneously termed the "constant current" method of modulation, the assumption being that the current in the single coil has a single

constant value. The error in this assumption can easily be proven from a simple mathematical treatment of the circuit. When this system is in proper adjustment, the modulation is extremely good with the additional advantage of controlling the entire antenna output rather than only a small portion as is the case with some other systems. When once properly adjusted, it will operate satisfactorily over a wide variation of operating conditions without further adjustment. It has the disadvantage of requiring at least two tubes of approximately equal output, and the output of only one tube is recoverable as high-frequency power for signal production. Two tubes used together as oscillators and modulated with a microphone in the antenna circuit will be required to produce theoretically the same signal when properly adjusted as one tube acting as oscillator and one as modulator.

Grid Modulation.—In the general consideration of vacuum tubes it was pointed out that the current in the plate circuit could be controlled in two different ways, by varying the plate voltage a given amount or by varying the grid voltage by a correspondingly much smaller amount. Thus the output of an oscillator can be controlled by the introduction of a variable voltage in the plate circuit or by a similar voltage of much smaller value introduced into the grid circuit. Fig. 25 illustrates a possible connection for grid modulation. The microphone is connected in series with a battery and the primary coil of the modulation transformer and the secondary voltage instead of being impressed on the grid of the modulator tube is put into the grid circuit of the oscillator tube directly. A condenser is connected across the terminals of the secondary of the transformer in order to allow the high-frequency currents to pass which would have otherwise been shut off by the inductance of the secondary winding. This condenser can also act as the grid condenser in the oscillating circuit, and the resistance of the secondary coil being

very high may serve as the grid leak resistance. This system is quite difficult to adjust and maintain in operating condition, and the results are in general much inferior to plate circuit modulation. It is difficult to modulate any considerable proportion of the output without getting into diffi-

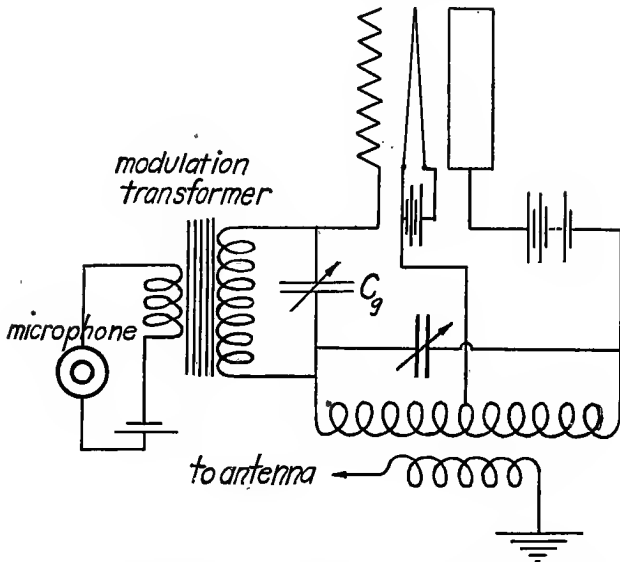

FIG. 25.—Transmitting tube arranged for grid circuit modulation.

culty due to the tube stopping oscillation entirely. When the voltage of the secondary of the modulation transformer makes the grid negative, the output is reduced but not proportionately. There seems to be a point of instability which when reached stops the tube oscillation instead of merely reducing it. This causes very poor modulation and is difficult to avoid if complete modulation is desired.

The value of the condenser C_o plays an important part in the proper adjustment and should be varied by trial for best results. It is difficult to maintain this system in adjustment as variations of plate voltage, filament current, antenna constants, etc., all seem to require compensating readjustments.

CHAPTER VI

RECEIVING EQUIPMENT

Tuning.—If one will depress the “loud” or damper pedal on a piano and sing some tone of constant pitch while the pedal is down the set of strings corresponding to that pitch will be set into vibration. This fact can be verified by suddenly stopping the tone and listening intently while the pedal is still held down when the string vibration can be recognized by a faint ringing tone produced by the vibrating strings. This phenomenon, which is known as “sympathetic vibration,” is the basis of all radio tuning. The transmitter sets up a note in the ether corresponding to the sound produced vocally and this radio “note” travels out in all directions and impinges on hundreds of antenna systems which correspond to the strings on the piano, but the only ones on which it has any appreciable effect are those which are tuned to the same frequency or wave length as the transmitted wave. To produce different tones on the piano we tighten or loosen the strings which are of light weight in the upper register and heavy in the bass section; in radio tuning we accomplish the same results by varying the inductance and capacitance of the circuit. In Fig. 26 several typical radio circuits are shown and the wave length to which these circuits are tuned can be computed from the relation

$$\lambda = 1884\sqrt{L \times C} \quad (\text{in meters}),$$

where L represents the total effective inductance of the circuit measured in microhenries and C is the total effective

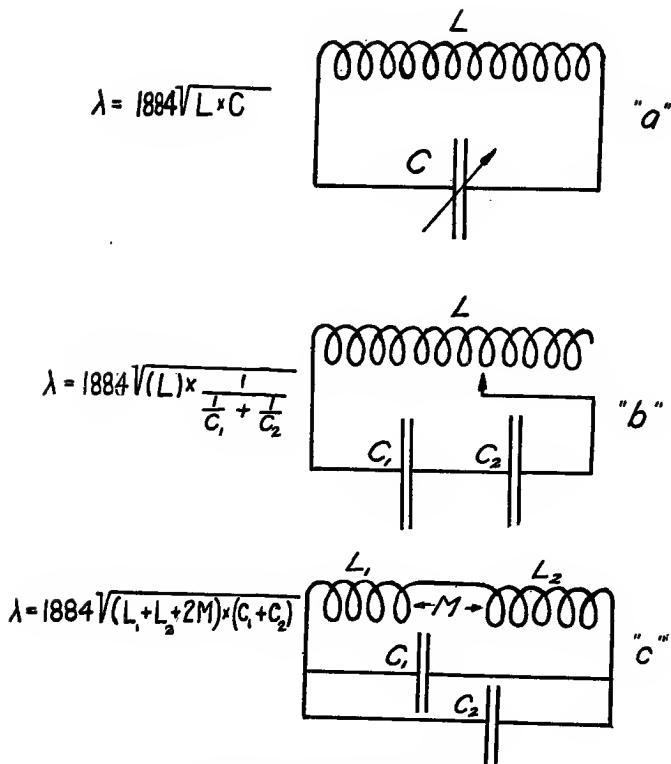

FIG. 26.—Typical radio circuits.

capacity of the circuit measured in microfarads. Where both quantities are lumped together we may substitute directly but in other cases the equivalent values must be computed.

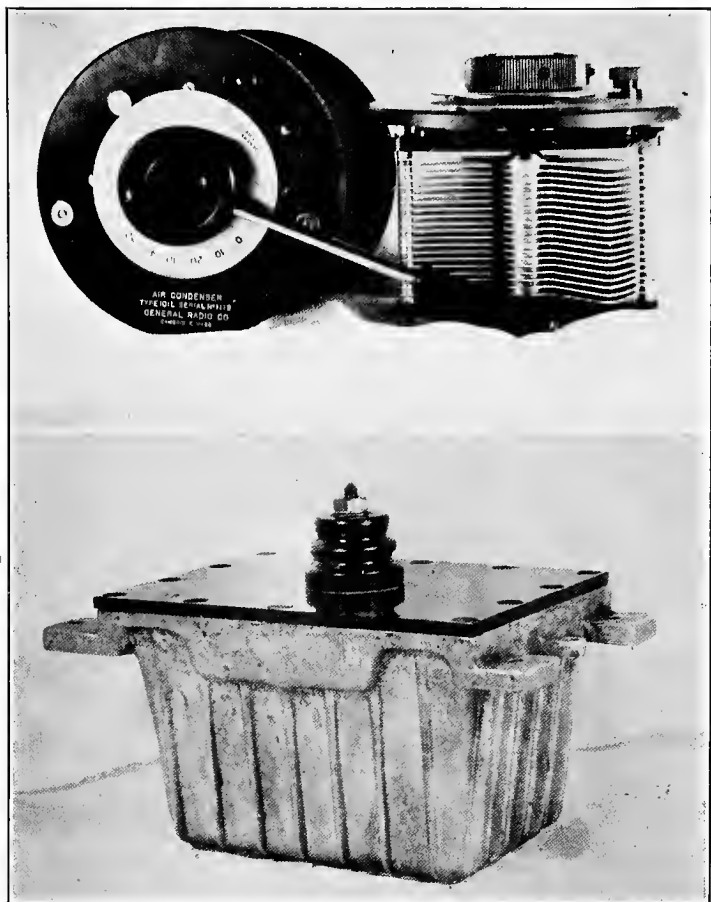

FIG. 27.—Low-voltage variable air condenser for receiving circuits above and high-voltage mica transmitting condenser below.

Condensers connected in parallel are added directly, while condensers connected in series are equivalent to a single condenser whose value is found by taking the reciprocal of the sum of the reciprocals of each of the individual condensers.

Inductances are handled just the other way around, when in series they add directly and when in parallel the resultant is computed in the same way that we handle series condensers. If one coil has an appreciable magnetic effect on the other coil there is another term called mutual inductance which must be taken into consideration. When the coils are connected in series the equivalent inductance is represented by

$$L_{eq} = L_1 + L_2 + 2M,$$

if the coils are wound so that the current passes in the same direction in the two coils. Where the coils are connected so that the direction of current flow is opposite in the two coils the $2M$ is subtracted instead of being added. L_1 and L_2 , the self-inductances of the coils, and M the mutual inductance of the two coils may be computed for simple cases from tables. The effect that mutual inductance has upon the parallel connection of inductance coils is rather complicated and beyond the scope of this volume.

Electrical Equivalent of the Antenna.—The ordinary elevated antenna is really a large-sized condenser, one plate of which is represented by the elevated wires, and the other one by the ground or counterpoise.

The wires of the antenna have inductance, hence the equivalent circuit would be represented as shown by the dotted lines in Fig. 28. On account of the fact that the inductance and capacity are uniformly distributed along the length of the antenna it is not possible to represent an antenna by single concentrated inductances and condensers.

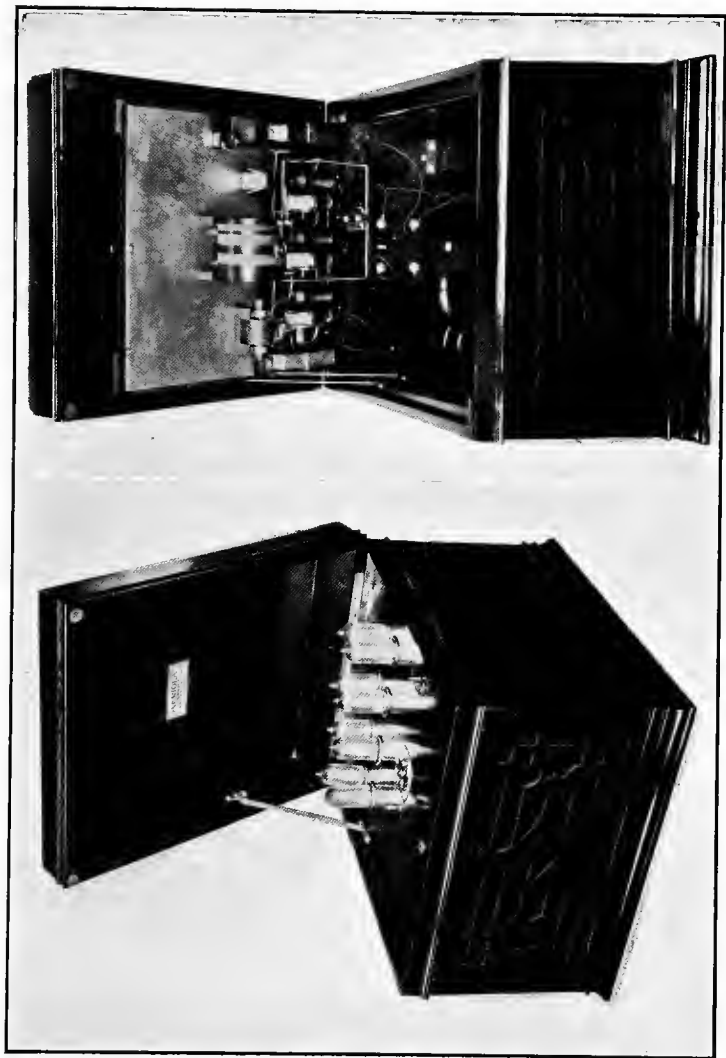

Two views of the Aeriola Grand, a self-contained tuner, detector, audio-frequency amplifier and loud speaker.



but values can be selected which will exactly represent the electrical equivalent at any single frequency.

Antenna Series Condensers and Inductances.—To reduce the wave length a condenser should be inserted in series with the antenna. This gives a circuit in which two condensers are connected in series and thus reduces the wave

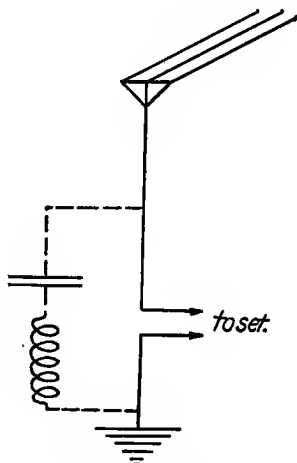

FIG. 28.—The electrical equivalent of the antenna.

length below the value which would have been obtained with the natural capacity of the antenna alone. By decreasing the condenser the wave length may be brought down to one-half its natural value but not lower.

The insertion of inductance in series with the antenna increases the effective inductance of the system and thus increases the wave length. There is no limit to the wave length obtainable in this manner.

Some receiving circuits employ detectors directly con-

nected to the antenna circuit and others use a second circuit connected to the detector and electrically coupled to the antenna circuit but insulated from it. In either case every circuit involved must be tuned to the wave length of the incoming signal.

Receiving equipment may be classified under three general subheadings, Tuners, Detectors and Amplifiers.

Tuners.—Under this heading come such combinations of coils and condensers as are capable of tuning the antenna and associated circuits to the proper frequency so that the incoming signal may be received at maximum intensity and undesirable signals weeded out. The choice of tuner depends almost entirely upon the detector employed, so that detailed consideration to various circuits will be given under the discussion of the various detectors involved.

Detectors.—The simplest type of detector is the “ crystal ” or “ mineral ” detector. It consists of a contact between some mineral and another electrical conductor which is sometimes in the form of a metallic wire and sometimes another mineral. These contacts have the property of conducting electricity easily in one direction and of shutting out more or less completely any current that may tend to flow in the other direction.

There are quite a number of substances which exhibit this peculiar one-way conduction and the following are usually used in connection with metallic points.

Galena.....	PbS
Carborundum.....	SiC
Silicon.....	Si
Iron pyrites.....	FeS ₂
Copper pyrites.....	CuFeS ₂
Pyrolusite.....	MnO ₂
Molybdenite.....	MoS ₂
Chalcocite.....	Cu ₂ S

A combination of zinc oxide and copper pyrites known as the "Perikon" detector is representative of the second class of detectors and gives very satisfactory results.

There are a large number of good mountings for crystal detectors of varying mechanical construction. A good mounting should fulfill the following requirements:

(a) Every part of the crystal surface should be easily and quickly accessible to the contact point.

(b) The pressure of the contact point should be adjustable from a very light contact to one involving considerable pressure.

(c) The crystal or crystals should be firmly embedded in the containing cup and make good connection with the outside circuit.

(d) The surface of the crystal should be protected from any accumulation of grease, dust, and dirt.

In order to satisfy the third condition the crystal should be mounted in an alloy of low melting point, as the use of solder or lead is apt to impair the sensitivity of the crystal on account of the heat. This alloy can be obtained from radio dealers or a substitute made by adding a few drops of mercury to a small amount of molten soft solder. Mounting in a glass tube effectually protects from the action of grease, dust, and dirt and allows an unobstructed view of the crystal surface at the same time.

Single Circuit Receiver with Crystal Detector.—A diagram showing the usual connections is given in Fig. 29. The incoming signal sets up a voltage in the antenna and this in turn produces a current which flows through the circuit comprising the antenna, tuning coil L , condenser C , and ground connection. The tuning or inductance coil is usually adjustable either by a provision for changing the number of turns included in the circuit or by the addition of another small coil connected in series with the main coil and arranged

so that it may be made to rotate inside the larger coil. This changes the mutual inductance between the two coils and hence varies the wave length by a variation of the $2M$ term in the expression for wave length given on page 58. This type of variable inductance coil is commonly known as a variometer and is illustrated in Fig. 30. Another illustration

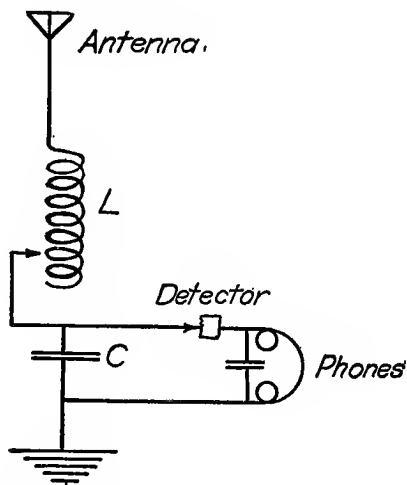

FIG. 29.—Simple crystal detector receiving set.

of this type of variable inductance coil can be seen in Fig. 39, which illustrates a set employing a single circuit receiver of different characteristics.

In operating a set of this character the movable contact in the crystal detector is brought into contact with the stationary crystal and adjusted to its most sensitive condition by moving it slightly while listening in the telephone receivers. There will usually be enough noise of one kind

or another present in the antenna circuit to adjust the point although in some sets a small high-pitched electric buzzer is provided to set up an artificial signal in the antenna circuit. When the crystal detector is carefully adjusted to its most sensitive condition the set is ready for tuning. This is accomplished by varying the inductance coil or condenser over the entire available range, listening meanwhile for the

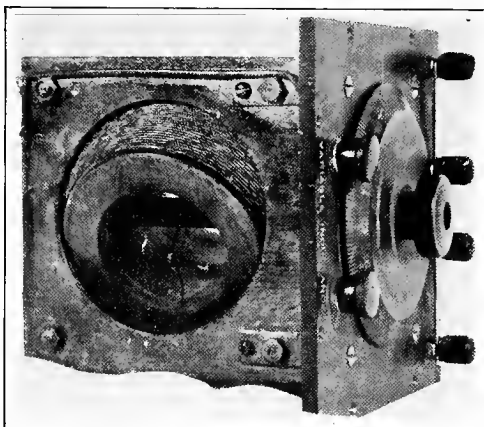

FIG. 30.—Variometer type variable inductance coil.

signal. When the signal is heard, readjust the detector point for maximum clearness. Unless the set has been previously calibrated with the particular antenna in use by means of a wavemeter the proper setting is most easily obtained by trial.

Theory of Operation.—The current produced in the antenna circuit of Fig. 29 is represented at *a* in Fig. 31. As was explained in the chapter on modulation, the outline or envelope of this wave corresponds to the sound wave trans-

mitted, but the individual pulsations of the wave are so rapid that it is impossible for the telephone diaphragm to follow them. This wave passing through the condenser *C* sets up a voltage wave across its terminals exactly like the current wave flowing down the antenna circuit but slightly behind it as regards time. This voltage tends to send a current similar to curve *a* through the telephones, but

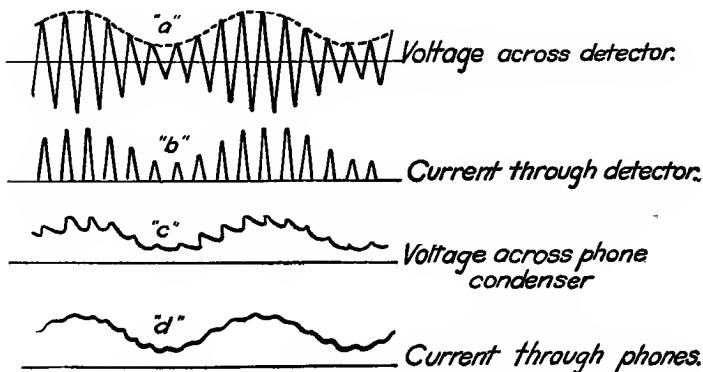

FIG. 31.—Currents and voltages in a crystal detector circuit.

the detector stops the flow of current in one direction while allowing it to pass in the opposite direction. The current flowing through the crystal detector will look like curve *b*. The condenser across the telephones acts like an electrical storage reservoir and the telephone windings bridged across the condenser act like a slow leak in the reservoir. One of the fundamental relations in the case of condensers is that the more electricity we put into the condenser the greater will be the internal pressure tending to discharge that electricity. The action is somewhat similar to an

automobile tire with a punctured tube. If we try to pump air into the tire the air will naturally leak out, and the rate at which air will leak out through the puncture will be determined by the rate at which we are pumping. In order to make it similar to the electrical case we must pump at the same number of strokes per minute and vary the rate at which air is being delivered to the tire by the length of the stroke. Consider that the height of each pulse of current shown in Fig. 31*b* represents the length of one stroke of the pump. Then when the strokes are long the pressure inside the tube will be increased before it has a chance to leak away and on the other hand the pressure will be low when the strokes are short. Curve *c* corresponds to what we might expect as regards pressure inside the tire and since the rate at which air leaks through the puncture depends upon the pressure of air inside the tire curve *d* might be expected to represent the rate at which air was leaking through the puncture. To come back to the electrical case, the pressure in the tire corresponds to the voltage (or electrical pressure) of the telephone condenser and the rate at which air leaks through the puncture corresponds to the current through the telephones. The reason that curve *d* is shown somewhat smoother than curve *c* is due to the smoothing-out effect of the inductance of the telephone windings. Thus we get a current in the telephone receivers which varies from instant to instant in accordance with the height of the received wave and since the height of the received waves is molded to correspond with the desired sound wave, the telephone diaphragm will reproduce the desired sound.

Sometimes the condenser across the telephones is omitted, the capacity of the telephone cords and windings being sufficient to store the requisite amount of energy.

Most inexpensive crystal detector sets on the market employ this circuit or a slight modification of it.

“ Loose Coupler ” Circuit.—The circuit just considered is very good where there is no interference from other stations operating on approximately the same wave length. Where such interference does exist, the two-circuit tuner or “ loose

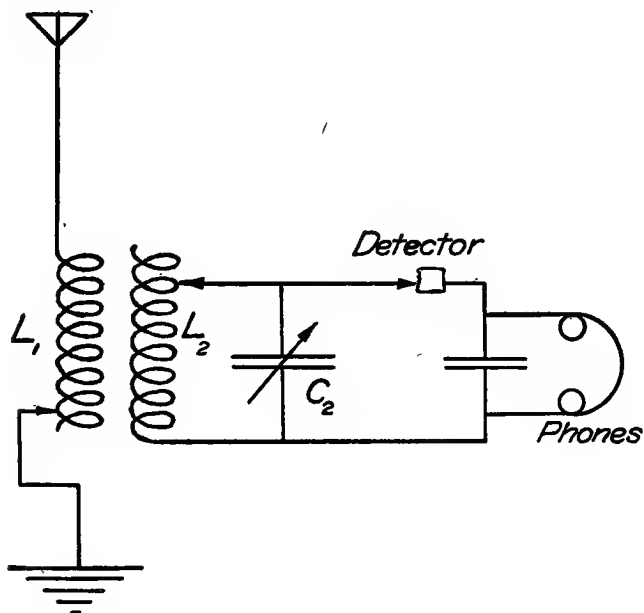

FIG. 32.—Crystal detector set using loose coupler.

coupler ” will give greater selectivity and “ sharper ” tuning and thus eliminate a considerable amount of interference. This circuit is illustrated in Fig. 32. Here L_1 and L_2 are two inductance coils arranged so that the number of turns included in each one is variable and so arranged that the position of the two coils may be varied with respect to each

other. In some cases the coils are coaxial and slide into one another, other forms cause one coil to rotate inside the other. The combination of the two coils and adjusting mechanism is usually spoken of as a "loose coupler," the "Navy" type indicating the sliding coil coupler and the revolving coil coupler going by the name of variometer coupler or "vario-coupler." The theory and operation of this circuit is essentially the same as that of the single circuit tuner previously described except that two circuits must be tuned instead of one. After adjusting the crystal to its most sensitive point as previously described find from the table supplied with the set the proper setting for L_2 and C_2 to give the desired wave length. Adjust the set to these values and with the coils fairly close together adjust the inductance L_1 until the desired signals are heard. Then reduce the coupling by bringing the coils further apart and retune if necessary. A change in coupling will change the wave length to which the set is adjusted, so the inductances L_1 and L_2 and the condenser C_2 must be again slightly adjusted to keep the signal at its maximum intensity. It is always desirable to use as loose coupling as possible, as interference from other stations is thus reduced to a minimum.

Tube Detectors.—The first vacuum tube detector was the so-called "Fleming Valve" and consisted only of hot filament and cold plate. Its action was merely that of a rectifier as has been described in a preceding chapter and it took the place of the crystal detector. Since it was no more sensitive than a crystal detector and required auxiliary batteries for its operation, it never became very popular and hence will not be considered here.

The three-electrode tube, however, is in almost universal use where the distances to be covered are great, and a sensitive detector is desired. A typical connection is shown in Fig. 33, here the circuit that was formerly connected to

the crystal detector and telephones is now connected between the grid and the filament of the detector tube.

The internal action of the vacuum tube has been discussed in a preceding chapter. There are two general explanations of the detector action in a vacuum tube, one when a con-

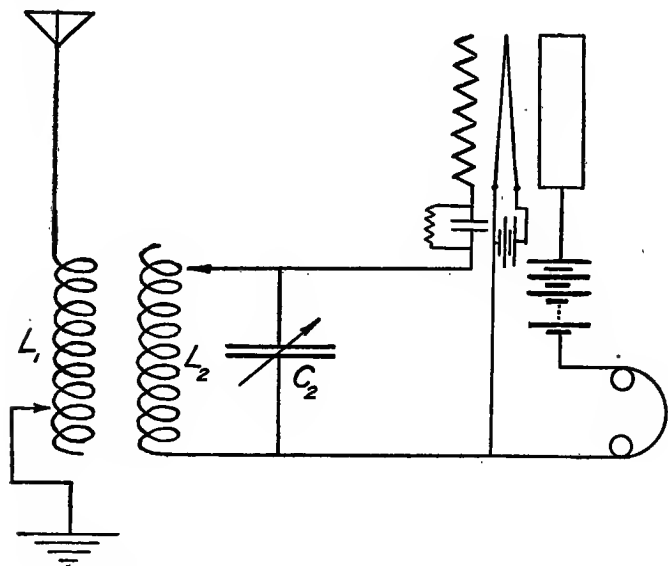

FIG. 33.—Non-regenerative vacuum-tube detector set.

denser is used in the grid circuit, the other without the grid condenser. Referring to Fig. 33 let E_c be the voltage induced across the terminals of the condenser C_2 due to the incoming signal.

Represented graphically it might look something like the wave marked E_c in Fig. 34. If we consider the positive parts of the waves as being above the line, and those below

negative, then when the grid voltage is positive a current will tend to flow in the grid circuit while no current will pass when the grid is negative. These pulses of current passing into the grid condenser on their passage through the grid circuit will charge it up so that it will produce a negative

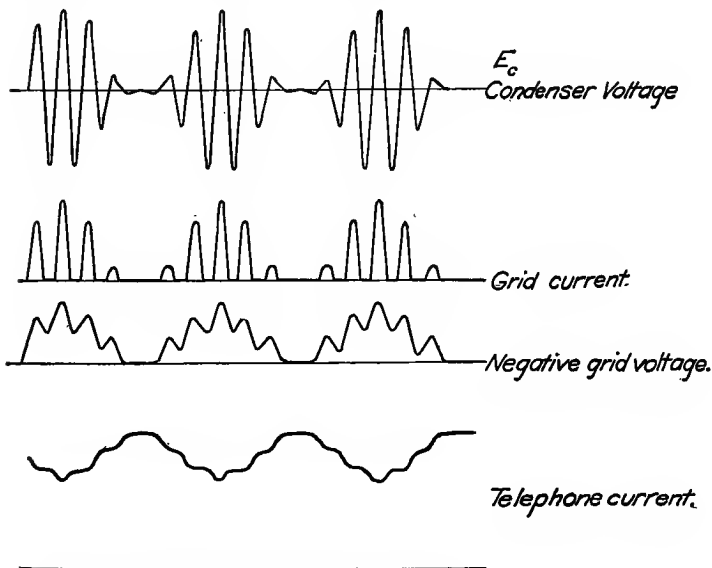

FIG. 34.—Voltages and currents in vacuum-tube detector circuit.

potential on the grid. In Fig. 34 the second line represents the current flowing through the grid circuit, and the third line the voltage to which the grid condenser is charged from instant to instant. The high resistance across the grid condenser prevents the condenser from becoming too highly charged and allows the charge to leak off continuously. Referring back to Chapter III we have seen that making

the grid more negative produces a decrease in the plate current, thus the plate current will vary as shown in the fourth line of Fig. 34. Since the plate current passes directly through the receivers, the magnetic pull on the receiver diaphragms will vary in accordance with the current flowing through them, and reproduce the desired sound.

It is not always necessary to use a "grid leak," as the high resistance placed across the grid is usually called. Theoretically, if no grid leak were employed the grid condenser would continue to charge up more and more until the grid became sufficiently negative to reduce the plate current to zero thus "blocking" the tube and making it inoperative, but practically this seldom happens in this circuit, as even when high-vacuum tubes are used there is usually enough leakage through the insulation to prevent blocking, and where "soft" or low-vacuum tubes are used the grid can pass quite a little current in the reverse direction, so that the grid condenser never becomes very highly charged and hence makes the use of a grid leak unnecessary.

Detector without Grid Condenser.—The grid condenser and grid leak resistance in Fig. 33 could have been removed and a direct connection made between the coil and the grid without entirely destroying the detector action of the tube. Although a tube with grid condenser usually gives better signals than one without, yet results in the second case are in general almost as good as when the grid condenser is used. Referring to Fig. 35, the curve showing the relation between grid voltage variations and plate current, it will be seen that for a given positive potential applied to the grid the amount of the increase in the current is much greater than the value of the decrease in current, which the same value of negative grid voltage would produce.

The signal voltage applied to the grid circuit is reproduced in the plate circuit, but its reproduction is distorted due to

the fact that when the grid voltage varies between equal positive and negative values, the plate current will show a much larger increase of current when the grid is positive than it will correspondingly show decrease of current when the grid is negative. These fluctuations in the value of the plate current cannot pass through the telephones themselves on account of the choking effect of the large number of turns

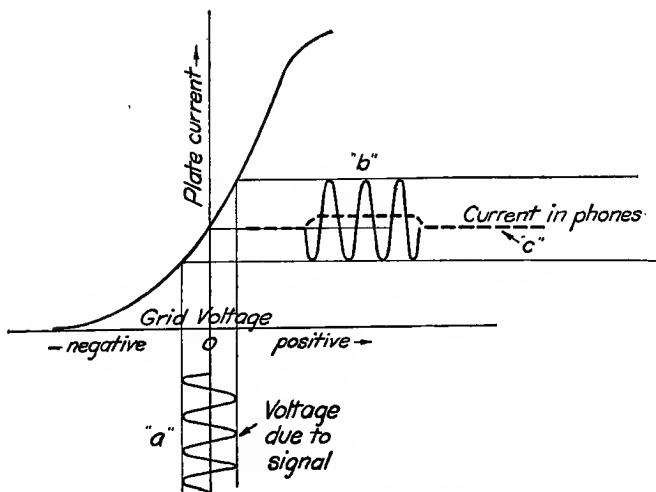

FIG. 35.—Detector action in vacuum-tube detector without grid condenser.

of wire of which their windings are composed, and hence they are "by-passed" through the capacity action of the telephone cords or through the condenser across the telephone if there is one. The current which flows through the telephone windings is the average value of the plate current, and thus the telephone diaphragm is made to vibrate so as to reproduce the desired sound.

These various currents and voltages are represented in Fig. 35, (a) being the voltage impressed on the grid circuit by the incoming signal, (b) the resultant plate current, and (c) the current that will pass through the telephone receivers.

When discussing the tube with grid condenser no mention was made of the effect of the distortion of the signal, and the consequent detector action which it induces, but to be exact

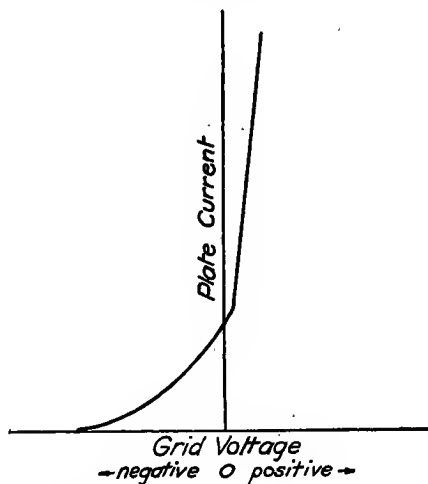

FIG. 36.—Grid voltage-plate current curve for a “soft” detector tube.

both these functions are present when using a grid condenser.

Soft Tubes.—Tubes that have an appreciable amount of gas left in them seem to make better detectors than those which are thoroughly exhausted, and this increased sensibility can best be explained by considering the relation between plate current and grid voltage in each case. Fig. 35 shows the relation between these quantities for a “hard” tube or one

in which the vacuum is very good and practically no gas present. Fig. 36 shows the same relation for a "soft" tube in which the vacuum is not quite so high and a small amount of gas remains. The sudden rise in plate current when the grid is made positive is due to "ionization" of the gas particles in the tube. The effect of ionization is to produce new electrons from the gas molecules and thus greatly increase

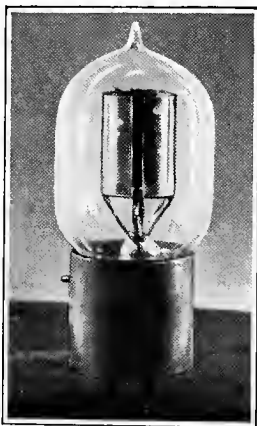

FIG. 37.—One type of "soft" or gas content detector tube.

the plate current whenever the grid voltage (or plate voltage) is brought above a critical value. This phenomenon is called "ionization by collision" and may be explained in the following manner. In a tube from which all gas has been exhausted and whose vacuum is very high, the electrons are unimpeded in their passage from the filament to the plate or grid. In tubes in which traces of gas remain this is not the case for according to the modern theory of gases numerous molecules of gas are constantly darting back and

forth inside the tube. A gas molecule ordinarily comprises a minute portion of gas, an electron or negative charge and an equal and opposite positive charge. These two charges are of equal value and opposite polarities so that their net effect is to make the molecule electrically neutral. As the electrons move from filament to plate some of them naturally collide with some of the gas molecules. The force of the impact depends upon the speed at which the electron happened to be traveling. The velocity of the electron is dependent upon the attraction of the plate and grid and this in turn depends upon the voltage applied to the plate and grid. If the electron is moving rapidly enough it will break up the neutral gas molecule and set free the negative electron which was formerly attached to it. The positive charge remains attached to the gas particle and is attracted by any negatively charged body in the vicinity. The requisite velocity for the electron to break up the gas molecule is very well defined and when the plate and grid potentials are raised to the proper point there is a sudden increase in plate current of very considerable value which produces the sudden rise in current shown in Fig. 36. If this action is very intense it may give rise to a visible bluish light inside the tube familiarly known as "blue glow."

The point at which ionization by collision begins may also be recognized by listening in the telephones. As the plate voltage or filament current is increased a point will be reached at which a hissing or frying sound is heard. This indicates the first stages of ionization by collision and the most sensitive adjustment of the tube as a detector is just below this hissing point.

Soft or gas tubes are very erratic in action and although more sensitive than well-pumped tubes are frequently displaced by hard tubes on account of the lack of sensitive adjustments and greater reliability of the hard tube.

A simple test of the degree of vacuum in any tube may be made by grasping the tube by the glass bulb end and touching any of the metallic connections to the high-tension terminal of a spark coil which is delivering about a one-half inch spark. One end of the secondary winding should be connected to the primary winding if not already connected. A very hard tube will produce no glow while a soft tube will vary from a bluish discharge on the inside surface of the glass to a glow which may completely fill the tube depending upon the amount of gas present.

Regenerative Receivers.—In Fig. 35 it was seen that the plate current consisted of two parts, one the low-frequency current corresponding to the sound wave which it was desired to receive and the other a high-frequency ripple of the same frequency as that of the incoming radio wave. The high-frequency ripple in the plate-current wave is of no particular importance in the action of the straight tube detector, but can be utilized by special means to enormously increase the strength of the signal.

In the chapter on tube oscillators we have seen that under proper conditions every variation in the voltage impressed on the grid produces a consequent variation of the plate potential, hence if the power on the grid from the signal received on the antenna is 1 microwatt, the plate circuit will produce an alternating-current output of the same wave form but of several times that amount, say 10 microwatts. If we arrange the receiver so that 1 microwatt is impressed back on the grid circuit from the plate circuit, the immediate result will be approximately twice the signal strength in the telephones, and 20 microwatts output of high-frequency signal energy. Since by supposition 1 microwatt in the grid circuit produces 10 microwatts in the plate circuit the high-frequency power in the plate circuit will automatically double itself since 2 microwatts of power are now

impressed on the grid, one from the antenna and one fed back from the plate circuit. This doubling of the power in the plate circuit automatically doubles the amount of power "fed back" to the grid from the plate circuit and this in turn increases the plate-circuit power. This action is cumulative and can thus enormously increase the effect of the signal voltage as impressed on the grid circuit. There is one limitation, when too much power is "fed back" from the plate circuit the tube will oscillate continuously as we have seen from the chapter on Tube Oscillators. For maximum signal then, the circuit should be adjusted to feed back just as much power as is possible from the plate to the grid circuit without making the tube self-oscillating.

Regenerative Receiver Circuits.—Regenerative receivers may be of either single- or two-circuit types as was explained in connection with crystal detector circuits.

Single-circuit Tuner.—One of the simplest single-circuit schemes is shown in Fig. 38. From the antenna the circuit passes through a variable condenser C_1 , down through the variable inductance coil L_1 to the ground.

Tuning may be accomplished by varying either the condenser C_1 or the inductance coil L_1 or as is the case of a popular commercial receiver both condenser and inductance are varied simultaneously. Increasing either the capacity of the condenser or the inductance of the coil will increase the wave length to which the receiver is tuned, and decreasing either or both of these values will shorten the wave length. The coil L_2 is connected in the plate circuit and is arranged so that its effect on coil L_1 in the grid circuit may be varied. Sometimes L_2 is mounted inside L_1 and arranged so that it can rotate inside L_1 , in other cases the coil L_2 is wound on the same form as L_1 and its effect upon L_1 controlled by a switch which can cut in any number of turns. The effect in either case is the same except that where the two coils are

in fixed relation to one another, and adjustment is effected by varying the number of turns, it is usually impossible to

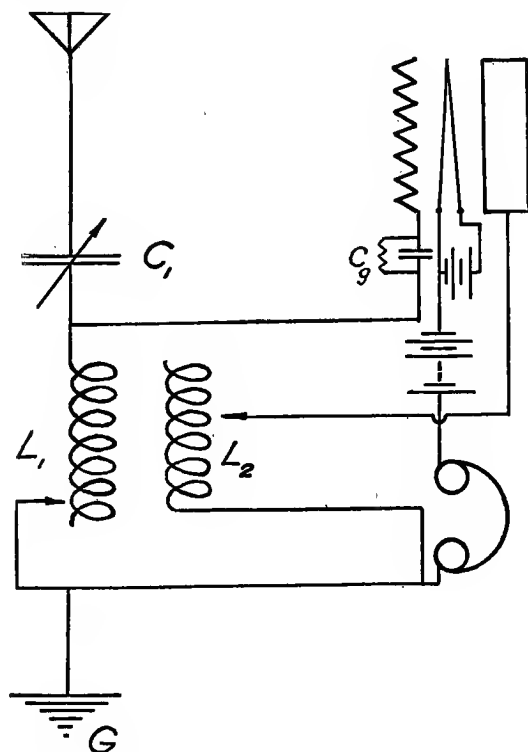

FIG. 38.—Single circuit regenerative receiving set.

obtain as accurate a control over the feed back and the consequent regeneration of the signal as is desirable.

In operating a set of this character adjust the tube filament current to the proper value, then tune for the desired signal by varying the condenser and inductance coil, the plate or

“ tickler ” coil being adjusted somewhat below its maximum value. When the desired signal is heard, increase the plate-coil adjustment until the signal is amplified to its maximum point. This point is just below the adjustment for the self-oscillating condition. A variation in the plate-coil adjustment will usually change the tuning of the antenna circuit and require a slight readjustment of condenser or coil to keep the signal at maximum intensity. Where it is desired to increase the wave-length range beyond that of the receiver alone an additional combination loading coil for grid and plate circuits is supplied with some sets.

The receiver shown in Fig. 39 is representative of the single-circuit regenerative set. Its circuit is essentially that of Fig. 38 except in certain minor details. The condenser C_1 is not continuously variable but is adjustable to one of two values by interchanging the antenna connection between the two binding posts on the right-hand side of the panel. Coils L_1 and L_2 are split up into several sections and are adjustable by the use of a variometer adjustment as may be seen from the illustration. The large handle controls the inductance of coil L_1 and the small knob to the lower left simultaneously controls the coupling between plate and grid circuits and the inductance of coil L_2 , hence the large handle would be used for tuning and the small knob for the control of regeneration. The tube used in this set is of special design and requires but two-tenths of an ampere to bring the filament up to normal brilliancy. The filament is of the coated type and consists of a very fine platinum strip coated with the oxides of certain of the alkaline metals and will consequently be ruined if operated above a red heat. The filament voltage is low enough so that an ordinary dry cell will supply it satisfactorily and the current taken is so low that a single cell will last quite a long time before becoming exhausted.

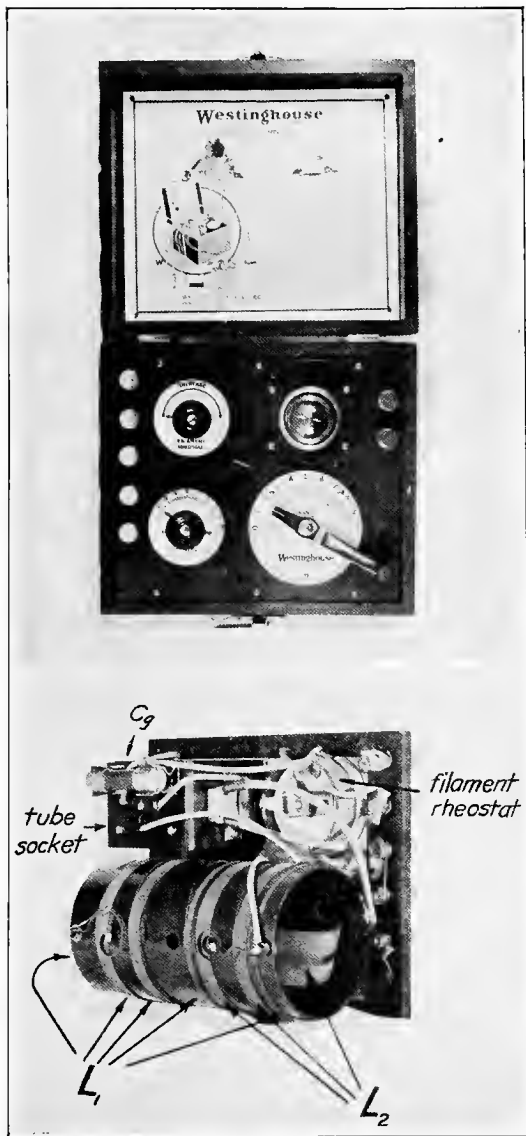

FIG. 39.—Single-circuit regenerative receiver.

The circuit used in the set illustrated in Fig. 40 is similar to Fig. 38. The condenser C_1 is varied by the large knob on the extreme left and the large knob in the center varies

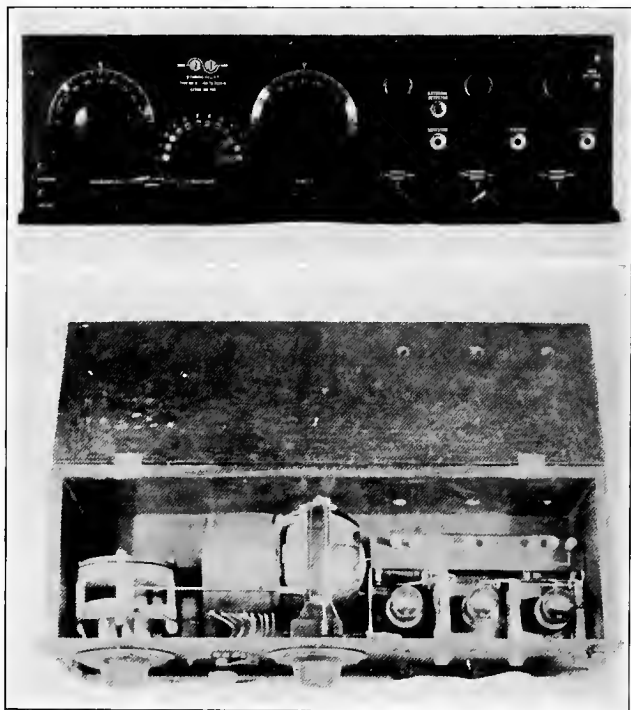

FIG. 40.—Exterior and interior of 150-3000 meter single circuit regenerative receiver.

the degree of regeneration. The coils are adjusted by the two-point switch which short circuits unused portions to eliminate dead-end losses. By varying both condenser and inductance this set will tune from 150 to 3000 meters without

additional loading coils. The tube detector and two-stage audio-frequency amplifier are mounted with the tuner in the same cabinet.

The single-circuit regenerative tuner is probably not as selective as the more complicated two-circuit tuner but will usually give better results in the hands of the novice as it is very much easier to adjust than the two-circuit tuner unless the operator has had long experience and will give a signal as loud or louder than the two-circuit tuner.

Two-circuit Tuner.—One type of two-circuit tuner employs the same system of feedback as that illustrated in the single-circuit regenerative receiver. Its operation is quite similar to the single circuit except that the antenna circuit is tuned separately from the closed or oscillating circuit. The general features are shown in Fig. 41. To tune the set to any desired wave length, adjust the values of L_2 and C_2 to correspond to the wave length desired, these values being obtained from manufacturer's data or other calibration of the set, and with the tube in operation and the plate-coil coupling adjusted just below the oscillation point, set the coupling between antenna and tube circuit at about 25 per cent of its maximum, and tune the antenna circuit. The correct adjustment of the antenna circuit will be indicated by the loudest signals in the telephone receivers.

It is usually advisable to loosen the coupling between antenna and tube circuits as much as can be done without making the signal too weak, as this adjustment will give maximum freedom from interference from other stations.

After the coupling has been loosened, go over the set and readjust all controls slightly for maximum signal intensity, as a change in coupling will cause a slight change in the tuning of the set. The adjustment of the plate-circuit coil is very important as signals may be enormously magnified by its proper control. In receiving radio telephony the

adjustment should be made so that the tube has just stopped oscillating, and is apparently just on the point of starting again. When the tube is oscillating, and radio telephony is being received, a "beat note" of adjustable pitch and usually

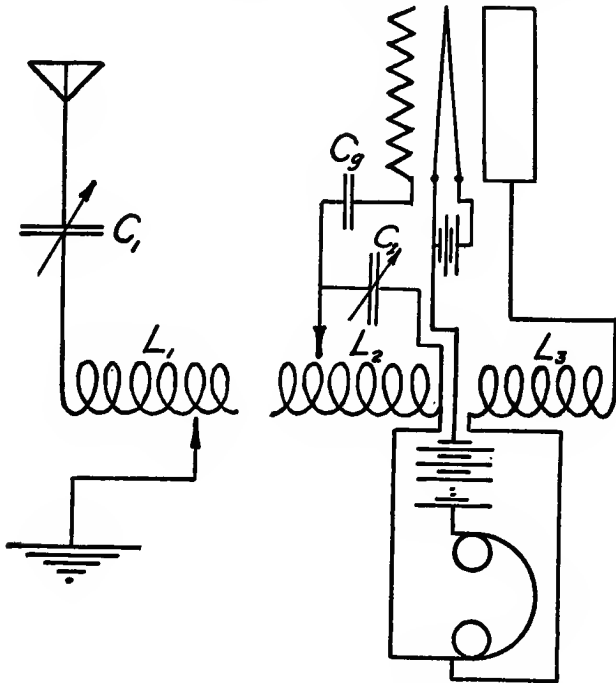

FIG. 41.—Two-circuit regenerative receiver with "tickler" coil.

very loud will be heard to the exclusion of the telephone signals. This "beat tone" can be eliminated by reducing the plate-coil coupling until oscillations cease, when the speech will be clearly received. In congested districts it is particularly undesirable to receive radio telephone signals

with the tube oscillating even though the beat note has been eliminated by tuning so that its pitch becomes lower and lower until it finally disappears, as the oscillating tube sends out weak radio waves from the receiving antenna, which will cause considerable interference with nearby stations tuned to approximately the same wave lengths. The plate coupling coil L_3 is frequently called a "tickler" coil.

Tuned Plate Receiver.—The coupling between plate and grid in the preceding circuits is principally of the type illustrated in Fig. 11 and known as magnetic coupling. Another type of receiver which has attained very widespread popularity in advanced amateur circles utilizes coupling illustrated in Fig. 12. The usual connections are shown in Fig. 42. The inductances L_g and L_p are replaced by two variable inductance coils V_g and V_p , usually built in the form of variometers, and the requisite condenser effects are obtained from the internal capacities of the tube itself and adjacent conductors. Receiving tubes are usually constructed with the conducting wires, which connect grid filament and plate, sealed into the glass fairly close together and separated by a layer of glass. The glass has high dielectric properties and the conducting wires separated by a thin layer of glass produce a considerable capacity effect. The capacity effects of the tube are illustrated in the diagram by the dotted circuit drawn above the tube.

As would be supposed, maximum regeneration is produced when the grid circuit is tuned to the same wave length as the plate circuit. If the capacity between grid and filament of the tube is the same as that between filament and plate then the inductance of the coil V_g plus the inductance of the secondary L_2 of the coupler should be equal to the inductance of the coil V_p . These capacities are seldom exactly equal hence there will usually be an unbalancing of the inductance in the plate and grid circuits to compensate.

This type of set is rather complicated to tune, and different operators prefer different procedures. One scheme would be to adjust the two variometers to approximately the same setting or until the tube started oscillating. The test for

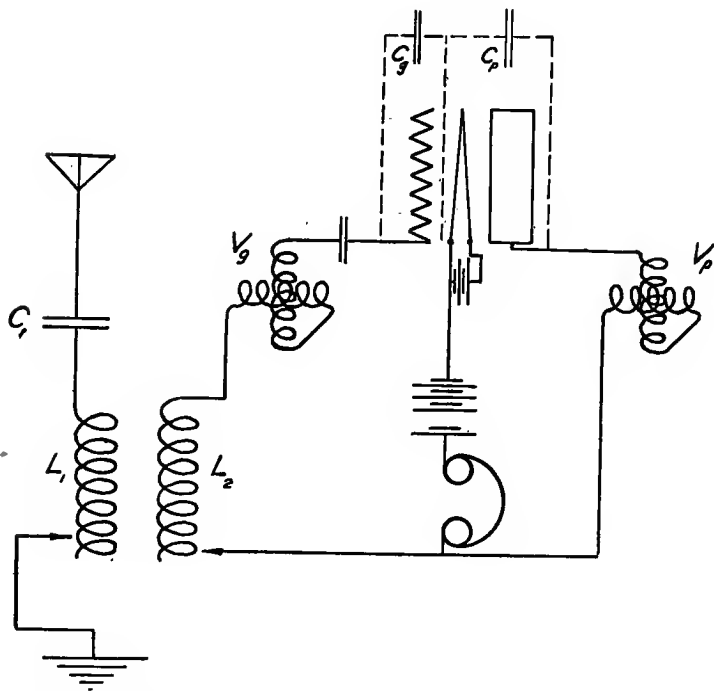

FIG. 42.—Two-circuit regenerative receiver with tuned plate circuit.

oscillation is made by touching the grid connection of the tube with the finger; if only a single click is heard in the phones either upon touching the contact or on removing the finger, the indication is that the tube is not oscillating, if

however a double click is heard, that is, a sound both upon making and breaking the contact with finger, and if these two clicks are of about equal intensity, it is an indication that the tube is oscillating. The test for oscillation is rather hard to describe, the sound produced is better described as a "cluck" rather than a click, but when it is once actually heard there will be no difficulty in recognizing it afterwards. After the tube has been set into oscillation close up the coupling to the antenna circuit somewhat, and adjust the antenna circuit until the signal is heard. In adjusting the antenna circuit to tune there will usually be two points at which a click will be heard in the telephones due to the fact that as the antenna circuit comes nearer to the proper adjustment it absorbs more and more energy from the oscillating circuit until oscillations are finally stopped. If the antenna adjustment is continued, a point will be reached where oscillations start again giving a second click. The point midway between the two settings at which clicks occur is the proper adjustment for the antenna. The coupling between antenna and tube circuit should now be reduced to the point where oscillations commence again, and then slightly increased until oscillations stop. This will give the best point for radio telephone reception. There are a number of other ways of adjusting the set to the proper point for regeneration, some operators prefer to reduce the antenna coupling to a low value and then stop the oscillations by mistuning the plate circuit to the proper point, this adjustment being very desirable where considerable interference is experienced from stations operating on wave lengths near the one which it is desired to receive. The proper operation of a set of this character requires quite a little experience, and the novice cannot expect to get the exceptionally good results that are possible with this set without considerable experience in its operation.

Amplifiers.—Where it is desired to receive a signal of greater intensity than can be obtained with a detector alone some type of amplifier must be employed. There are two general types of amplifiers, those which amplify the signal before it has been rectified and those which amplify the signal after it has passed through the detector. The first class are called “radio-frequency” amplifiers and the second class, “audio-frequency” amplifiers. Since at present audio-frequency amplifiers are in the most extensive use, they will be considered first.

Audio-frequency Amplifiers.—The principle on which all tube amplifiers operate is embodied in the relation previously discussed whereby any alternating voltage impressed on the grid circuit of a tube will reproduce itself in the plate circuit, enlarged many times. The usual connection is shown in Fig. 43, the primary circuit terminals *A* and *B* are connected in place of the telephones in the detector circuit. The signal voltage from the detector is stepped up in the transformer *T*, and the secondary voltage is applied between grid and filament of the tube. This grid voltage controls the output of the plate battery in accordance with the impressed signal and varies the current through the telephone receivers. The signal produced in the telephones is thus increased in intensity many times over the original signal received from the detector. Referring to Fig. 43 it will be noticed that part of the filament current regulating resistance is included in the circuit between grid and filament. The voltage drop in this resistance due to the filament current flowing through it gives the grid a slight negative “bias.” Amplifiers usually operate better with a slight negative bias, the amount varying with the tube, but usually about one volt in value.

If further amplification is desired another stage can be added by connecting the primary terminals of the transformer of the second tube to the points marked *A'* and *B'* and the

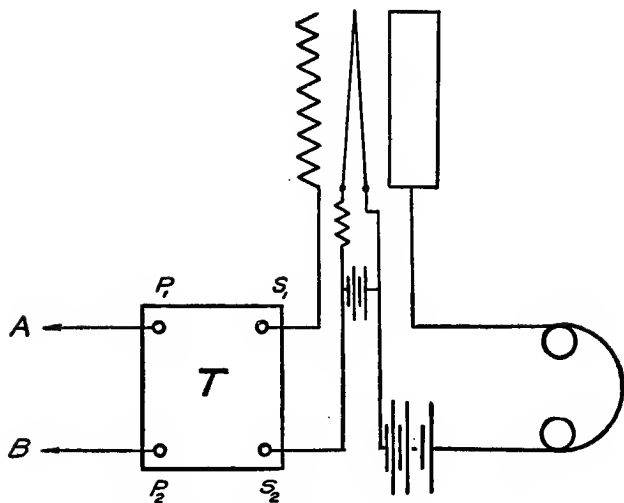

FIG. 43.—Single-stage audio frequency amplifier.

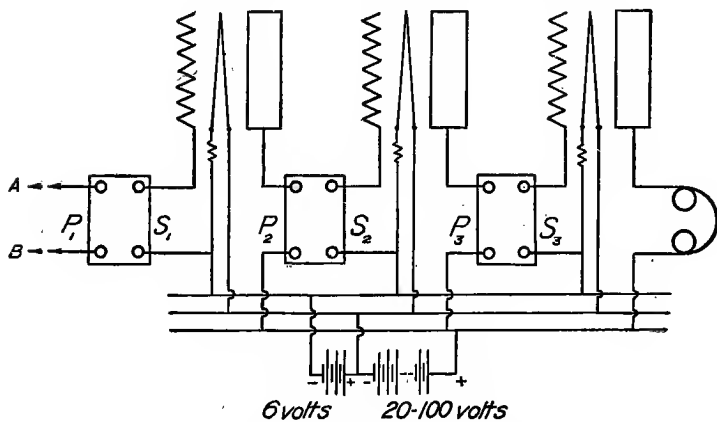

FIG. 44.—Three-stage audio-frequency amplifier.

telephones in the plate circuit of the second tube. A three-stage amplifier is shown in Fig. 44 in which the same filament and plate batteries are used for all three tubes. The use of more than three stages of audio frequency is usually not to be recommended as there is usually a very pronounced tendency for the amplifier to "howl" or produce oscillations of audible frequency continuously. This is usually due to some of the amplified energy of the last stage finding its way back to the grid circuit of the first tube. Since the amplification is so high only a very slight "feed-back" coupling is necessary to produce the howl and special means are usually necessary to prevent it. The most desirable condition would be to have each stage of amplification enclosed in a separate iron case which is connected to ground. This would prevent either magnetic or electrostatic coupling between steps, but since this is difficult to accomplish the different stages are usually separated by grounded metallic screens. It is usually desirable also to ground one side of the filament battery as well as the iron cores of the amplifier transformers.

Audio-frequency Amplifying Transformers.—Audio-frequency transformers are usually constructed with laminated iron cores of the closed-core type. The construction is such as to produce a minimum amount of electromagnetic disturbance outside the core on account of the undesirable feed-back coupling which it might produce, and the consequent howling of the amplifier. The windings are composed of many thousands of turns of extremely fine wire insulated with an enamel coating, the total diameter of the wire and insulation being much less than that of a human hair. Each layer is separated from the next by a layer of very thin paper and the whole winding impregnated with some type of insulating compound.

The secondary coil usually contains from three to nine times as many turns as the primary coil, thus producing

a step-up action on the voltage impressed on the grid.

Amplifying Tubes.—The general construction of tubes used for amplifying purposes is usually exactly the same as those used as detectors, with the exception that amplifying tubes are usually exhausted as far as possible, and contain a minimum amount of gas. However, detector tubes may be used for amplification providing that the plate voltages employed are not sufficiently high to produce appreciable "blue glow" in the tube.

The detector tubes offered on the market will operate fairly well as amplifiers if the plate voltage does not greatly exceed the normal $22\frac{1}{2}$ volts.

When hard tubes designed for amplification are used the plate voltage may be increased considerably with better results. The amplifier plate battery may consist of as many as four or five standard $22\frac{1}{2}$ -volt plate batteries or even more in certain cases.

Certain amplifying tubes are exhausted by the "chemical" process, that is they are pumped down to a fairly low degree of vacuum with mechanical pumps and then sealed off at the tip. The degree of vacuum produced by the mechanical pump is not nearly high enough for tube operation, so certain chemicals are introduced inside the tube before sealing off which will take care of the remaining gas present. One scheme involves painting the filament support wires with a red phosphorus emulsion. Red phosphorus is normally inert but when the tube filament is lighted the connecting wires become heated and the red phosphorus is changed to yellow phosphorus and vaporized. Yellow phosphorus and its compounds have an intense affinity for oxygen and water vapor, and if the tube is in operation with voltages around fifty or above, the electrical discharge combines the remaining gases with the phosphorus in a way not yet well under-

stood. The metal parts inside the tube slowly give up gas during the first few hours of their operation and this gas is absorbed provided the plate voltage is around fifty volts, but little or no action takes place with plate voltages below this point. Thus if a tube of this character which has not been sufficiently hardened is used with a $22\frac{1}{2}$ -volt battery, the action usually gets worse and worse since there is no clean up going on at this voltage. The remedy would obviously be to increase the plate voltage to say 100 volts and operate it at slightly above normal brilliancy until all the gas has been gotten out of the electrodes and combined with the phosphorus. Then the voltage can be reduced to $22\frac{1}{2}$ volts again with satisfactory results. If 100-volts direct current is not available, the 110-volts alternating current lighting voltage supply can be used instead. It is best to connect a 25-watt lamp in series with one lead in order to protect against any possible short circuit that might occur.

Radio-frequency Amplification.—Amplification of the signal before passing it on to the detector offers a number of advantages. When radio-frequency amplification is combined with a detector and audio-frequency amplifier it is possible to get an almost unbelievable amplification of signal.

The general principles involved are similar to those of audio-frequency amplification and the point of difference lies in the fact that the transformers must be designed for radio frequencies instead of audio frequencies.

It is somewhat difficult to amplify signals of lower wave length than 600 meters on account of the prominent part the capacities of the tube play in the circuit. However, with certain tubes, which are specifically designed to give very low internal capacities, very fair amplification may be obtained on waves much shorter than 600 meters. The design of the coupling transformer depends almost entirely upon the characteristics of the tubes used and the wave-length ranges

to be covered. They contain a comparatively few turns of wire wound on special iron cores. The iron used in these cores is rolled very much thinner than that used in audio-frequency transformers and each sheet is very carefully insulated from its neighbor with a thin coating of varnish.

Some coupling transformers are built without iron cores and wound on forms composed of insulating material. This

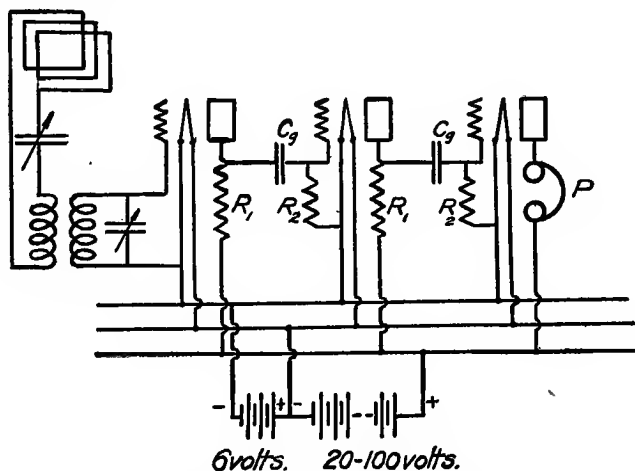

FIG. 45.—Three-stage radio-frequency amplifier with resistance coupling connected to loop antenna.

type requires more turns than the iron-cored type but is simpler to construct.

Resistance coupling is sometimes employed for short wave lengths, and while not nearly so efficient as transformer coupling has the advantages of simplicity and equal amplification over a wide band of wave lengths. A typical circuit is shown in Fig. 45. Using a coil about 4 inches

in diameter and containing thirty or forty turns as antenna in the author's laboratory, no difficulty was experienced in picking up signals many hundreds of miles away when five stages of amplification were used.

The chief advantage in radio-frequency amplification lies in the fact that several stages of radio- and audio-frequency amplification can be used in the same set without any very pronounced tendency for howling, which condition would be almost impossible to avoid if an equal number of either audio or radio stages were used.

Telephone Receivers.—The telephone receivers used in radio differ internally from those used in wire telephony principally in the winding on the electromagnets. Radio receivers are wound with very fine wire and have a very large number of turns on each coil. Wire telephone receivers operate with much larger currents than it is convenient to obtain in radio, hence radio receivers have to have many more turns to compensate for it, since .1 ampere flowing through ten turns produces the same magnetic effect as 1 ampere flowing through one turn. This makes the resistance of the windings rather high, usually between 1000 and 1500 ohms for each receiver, the resistance being a sort of necessary evil due to the small wire and large number of turns employed.

One type uses a diaphragm of sheet mica instead of iron and the magnets instead of acting directly on the iron act on a light auxiliary armature which in turn is connected with the center of the mica diaphragm. Due to the special construction of the coil and magnetic circuit, and the excellent vibrating qualities of the mica diaphragm, this type of receiver is very sensitive and will give a very loud response to strong signals. It is quite well suited for use in so-called "loud speaking" telephones.

Unfortunately the most sensitive radio telegraph receivers

are not always the best suited for radio telephone reception. By properly designing the diaphragms, it is possible to make them very sensitive to any certain frequency to the exclusion of other frequencies. Since the note which most modern spark telegraph stations use is around 1000 cycles, corresponding to the pitch of "high C," receivers for telegraph use frequently have their diaphragms tuned to a point near 1000 cycles. This is very undesirable for radio telephone work as it causes serious distortion of the speech, certain high notes are very much exaggerated while others are badly suppressed, thus distorting the speech or music to a very unnatural degree. The more modern receivers are designed to be equally sensitive for all frequencies within the audible range and have no one sensitive frequency.

Loud Speakers.—Where a number of persons desire to receive radio signals it is sometimes desirable to eliminate the individual telephone receivers and use a single loud-speaking unit in connection with a horn.

It is not possible to utilize the ordinary type of iron diaphragm telephone receivers for producing very loud sounds on account of the limitations imposed on the vibration of the diaphragm by the nearness of the magnetic pole pieces. When the current exceeds a certain value the motion of the diaphragm is increased to such an extent that it will hit against the magnetic pole pieces and produce a rattling sound.

The Baldwin or mica diaphragm type of receiver, however, has considerably more leeway due to its mechanical construction, and when used in connection with a suitable horn will operate fairly well if not overloaded.

Better results are obtained when diaphragms of metal are substituted for the mica diaphragms usually furnished with this type of receiver, on account of the distortion present when mica is used. The mica diaphragms are very

light and unduly responsive to the higher pitched tones, and although this is desirable in receivers used for telegraphy it is undesirable for telephony. One type of loud speaker employing the Baldwin receiver uses a thin aluminum diaphragm in which there is a series of concentric circular depressions, thus greatly reducing the distortion due to the mica diaphragms.

Electrodynamic Receivers.—Where extremely loud signals are desired such as would be required to fill large auditoriums, the electrodynamic type of loud speaker can be used.

In Fig. 46 the essential parts of one type are illustrated. Instead of employing permanent magnets electro-magnets are used to produce the magnetic field. In this field is a coil of wire wound on a light cylindrical form, and the sound currents are led through this coil. The coil and field are so related that a mechanical force is exerted on the coil when it is carrying current, and this force is in turn transmitted to the diaphragm to which the coil is rigidly attached. A reversal of the current reverses the direction of the pull on the diaphragm, thus reproducing the variations of current in the pull exerted on the diaphragm. Referring to the figure, the coil connected to the 6-volt battery actually contains many hundreds of turns instead of the few shown and produces a magnetic field which passes through the core around which the coil is wound, to the upper end where it branches in all directions through the air gap in which the moving coil is situated, completing the circuit through the outside casing of the magnet. Current from the receiving circuit is led into the moving coil through a pair of flexible conductors not shown on the sketch. It can be seen that the moving coil has almost unlimited freedom of movement, hence if the sound currents are large the volume of sound produced may be enormous. The makers claim that under

favorable conditions sound has been transmitted a distance of several miles by its use.

The moving coil is composed of comparatively few turns of rather coarse wire, hence if it is desired to use it in place of a high-resistance radio telephone receiver a transformer must be used to increase the current and lower the voltage of the

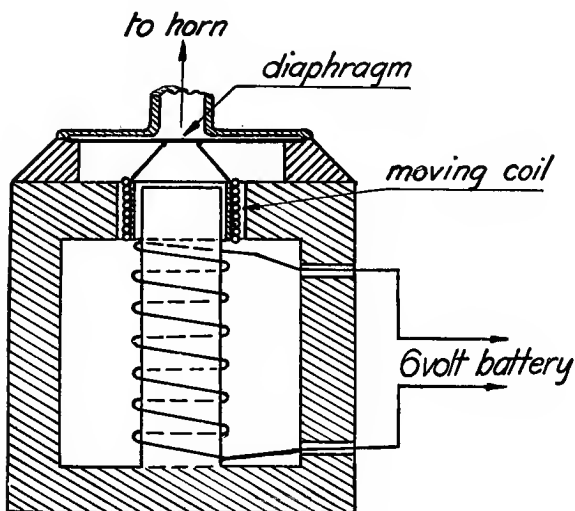

FIG. 46.—Electrodynamic type of loud speaker.

signal. The coil on the transformer with the larger number of turns is connected in place of the radio receiver, and the one with the smaller number is connected to the moving coil.

Where efficient operation is desired the last stage of the amplifier should contain a "power" tube operated at its normal plate voltage. The electrodynamic receiver is capable of handling an output of several watts efficiently,

and the signal must be amplified accordingly if maximum response is desired.

Push-pull Amplifier Connection.—In order to avoid the usual serious distortion of speech and music when high amplification is employed the push-pull circuit has been devised. While some of the distortion may usually be traced to improperly operating loud speaking devices a con-

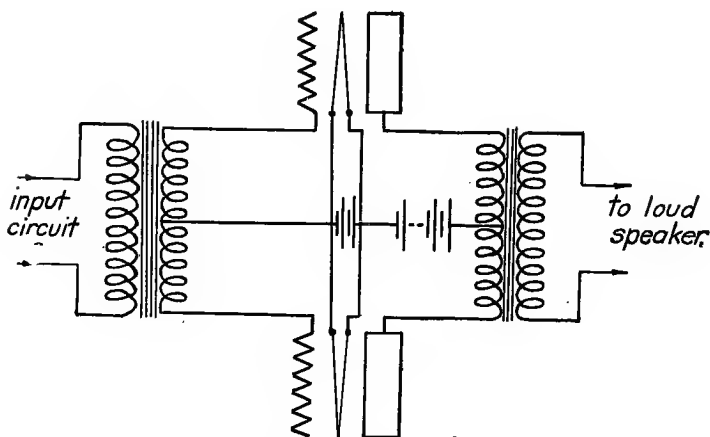

FIG. 47.—Push-pull amplifier circuit.

siderable proportion is due to the distorting effects of the tubes themselves. This connection which is illustrated in Fig. 47 requires special transformers with double windings and eliminates most of the tube distortion by increasing the plate current in one tube while it is decreasing the plate current in the other, and when the effects of the two currents are taken together they give a response exactly proportional to the grid voltage. Where the signals are weak the ordinary

single-tube connection gives satisfactory results but after they have been amplified up through several stages some type of distortionless connection must be used in the last stages if clear signals are to be obtained from the loud speaker.

CHAPTER VII

TRANSMISSION

Antenna and Ground Systems.—The function of the transmitting antenna is to change the electric power produced by the radio transmitter into electromagnetic waves and to start these waves on their way to the receiving station. At the receiving station the function of the antenna is to change the electromagnetic energy which it absorbs from the passing waves into electrical energy of such form as will operate the receiving apparatus. The transmitting antenna is energized by the radio transmitter and the energizing currents which flow into the antenna set up around it disturbances in the surrounding "ether." Ether is the name given to the all-pervading "something" which exists everywhere and which serves as the medium through which electromagnetic waves travel, whether they be light, heat, or radio. Ether bears the same relation to electromagnetic waves that the surface of the water bears to water waves or that air bears to sound waves.

Waves set up by mechanical means are quite similar in many respects to those set up electrically, so a brief discussion of a mechanical case may be an aid to the understanding of the electrical one. Suppose we set up a wave in water by poking a stick up and down in the water. The first thing that happens is that some of the water is pushed aside or displaced when the stick is placed in the water. When the stick is withdrawn most of the water that was dis-

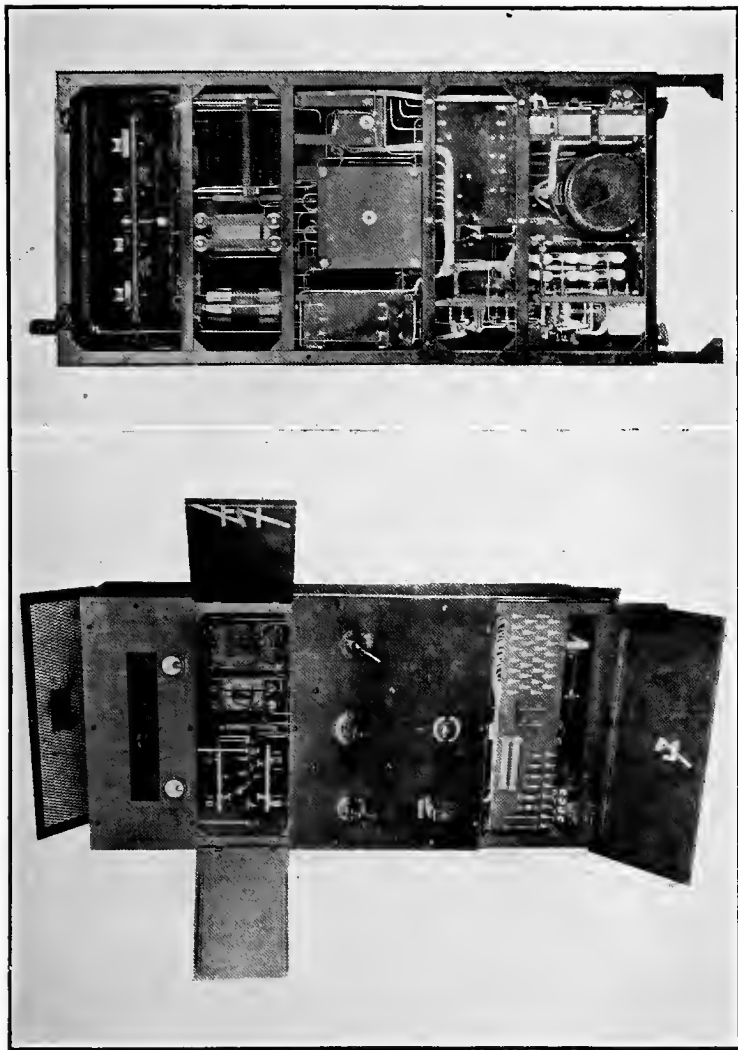

1-kilowatt tube transmitter. The four large tubes in the upper part of the set can be connected in parallel for radio telegraphy or two may be used as oscillators and two as modulators for radio telephony. The smaller tube is used to amplify the speech before it is impressed on the modulator tubes.

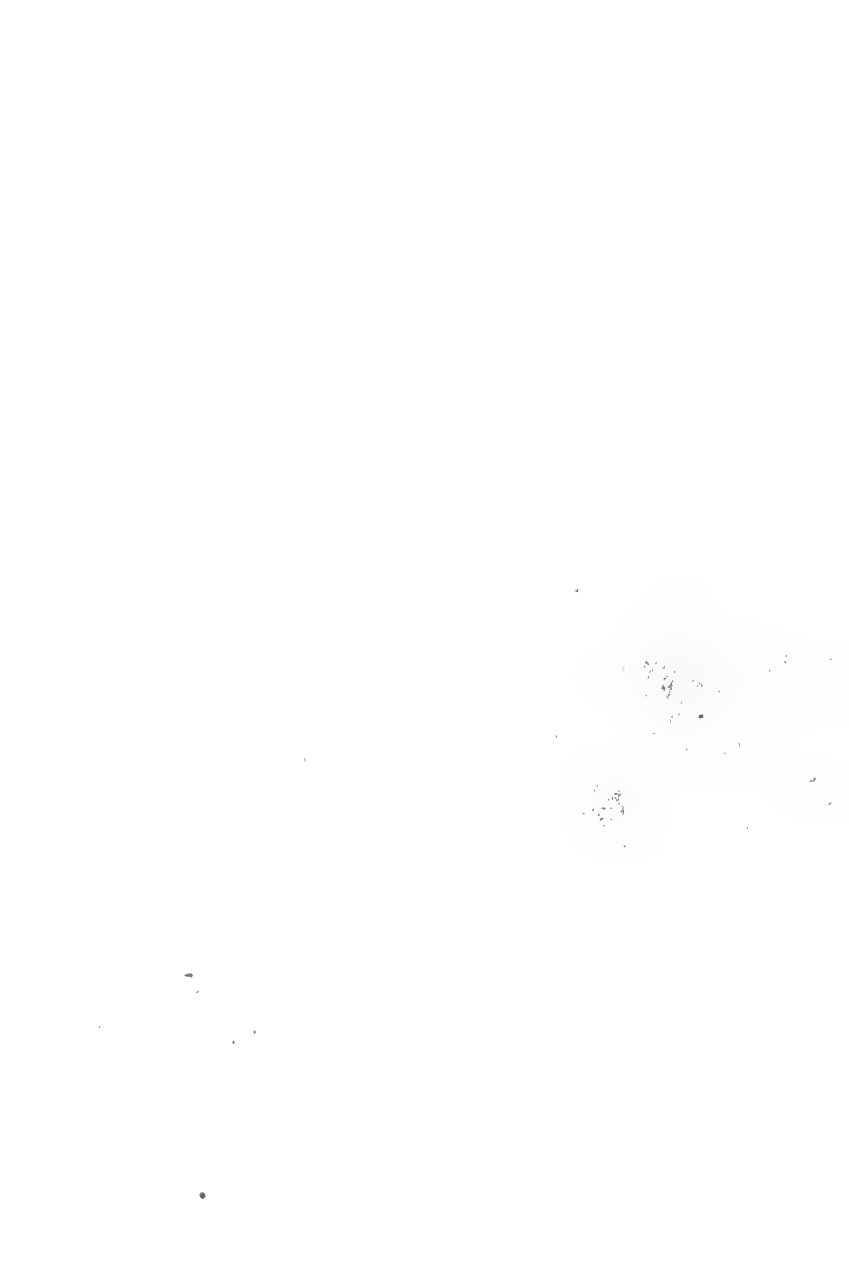

placed flows back into its original position, but in addition to this return of the displaced water, a displacement wave is sent out in all directions. The case with the radio antenna is quite similar, the current flowing into the antenna produces an electromagnetic and electrostatic disturbance in the surrounding ether which has a tendency to restore itself to the normal condition just as soon as the cause is removed. However, when the current in the antenna does finally reach zero the disturbance in the ether does not entirely collapse on the antenna without setting up a "disturbance" wave in all directions from the antenna. When the current in the antenna reverses, due to the action of the radio transmitter, a similar disturbance is set up around the antenna except that this disturbance has the opposite polarity to that originally produced, and a portion of it is also radiated away just as in the first case. This rapid succession of positive and negative disturbances are thus radiated out in all directions from the transmitting antenna and finally impinge upon the receiving antenna system. Radio waves have the power of setting up the same kind of disturbance in the receiving antenna as that required to produce them in the transmitting antenna. Similarly, waves produced by moving a stick up and down in water will tend to move other sticks on which they have a chance to act in the same manner that the first stick was moved.

Ether waves travel at the speed of light (light being an ether wave), 186,000 miles or 300,000,000 meters per second. Suppose it takes one-millionth of a second for the current in the transmitting antenna to change from its maximum positive value through zero to its maximum negative value, then the positive wave will have had one-millionth of a second start on the negative wave and will have traveled one-millionth of 300,000,000 meters before the negative starts. As they are both moving at the same speed there will be a

constant distance of 300 meters between the peak of the positive wave and the peak of the negative wave. This would correspond to the distance between the crest and the trough in the case of a water wave and the distance between crests would naturally be twice that amount. Similarly we consider the wave length in the case of the electric wave as being the distance between successive positive peaks and this distance would be 600 meters under our assumption. If it requires one-millionth of a second to pass from positive through zero to the negative maximum, it will require twice this time to complete a cycle, or two-millionths of a second. If it takes two-millionths of a second to pass through a cycle, cycles will occur at the rate of 500,000 per second, in other words the frequency corresponding to a 600-meter wave is 500,000 cycles per second. The relation between wave length and frequency is therefore

$$\text{wave length} = 300,000,000 / \text{frequency. (in meters)}$$

Elevated Antenna.—For general reception and transmission work it is usually advisable to erect an elevated antenna consisting of one or more wires. It is essential that the antenna be carefully insulated from the ground and all other conductors. It is not necessary to use insulated wire although there is no objection to its use, the insulation being usually obtained through the use of good insulators at the ends and wherever else support is needed. For reception it is generally sufficient to erect but a single wire as multiple wire antennae are of advantage principally in transmission work, and the expense of more than one wire for receiving is usually not justified. The most desirable characteristic in any antenna is height, the higher the antenna the greater the amount of signal energy that will be absorbed from the passing wave and the louder the signal. Additional length

will partially compensate for lack of height but there are limits in the total length of an antenna above which it is not desirable to go. The natural wave length of any antenna (or wave length at which it will oscillate most easily without coil or condenser in series with it) is roughly speaking from four to five times the actual length of the antenna. The figure four applies most nearly to vertical antennae and five to long low horizontal antennae. By the use of a series condenser it is possible to tune down to a value only slightly above one-half the natural wave length with one-half the natural wave length as the lower limit. To increase the wave length we add inductance coils in series and there is no limit to which an antenna can be loaded in this manner.

For example let us suppose that an antenna for reception on 300 meters is desired. The upper limit of length would be computed from one which had 600 meters for its natural wave length, and assuming the four to one relation, we find that the maximum total antenna length must not exceed 150 meters or 490 feet. Thus, if we had two 50-foot poles available we would set them not more than 440 feet apart and erect an antenna 440 feet long and about 50 feet high. Actually such an antenna would probably be cut down to 300 feet or less on account of the additional ease in tuning. If a single-circuit tuner is to be used it is best to follow the directions accompanying the apparatus as the specified wave-length range will only be obtained when the antenna has the specified dimensions. A large antenna will increase both maximum and minimum wave lengths to which the set may be tuned while an antenna smaller than that called for will decrease both these values.

In Fig. 48 several different types of antennae are shown. The inverted L is probably the most common type as it is easy to erect and quite efficient. For very short-wave transmission and reception the T antenna is quite desirable.

Here we get twice the length in the horizontal portion without producing a natural wave length much greater than that which would have been obtained if one-half of the horizontal

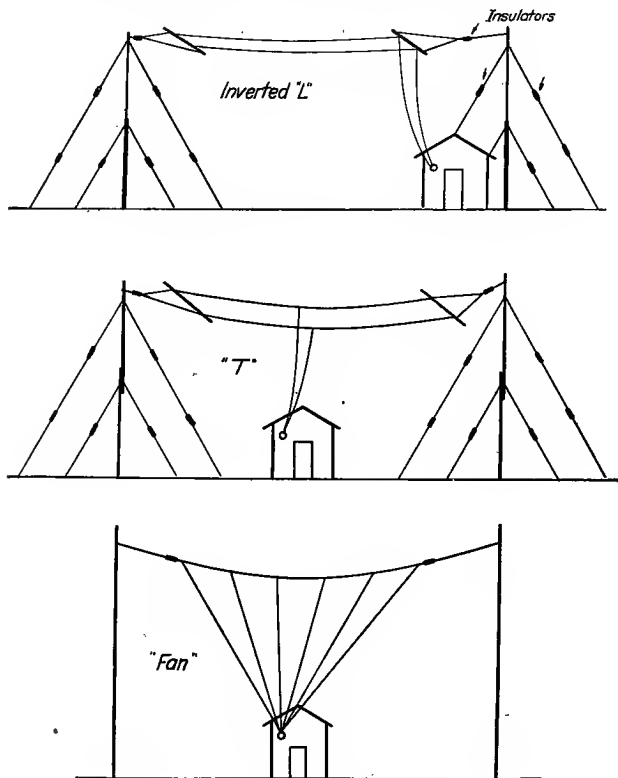

FIG. 48.—Types of antennae.

portion had been removed. The fan antenna is well adapted for transmission but apparently offers no particular advantages in reception.

Antenna Construction.—The actual construction of any antenna will depend very largely upon the supports available. If one end is to be attached to a house and the other end to a tree or similar support, the inverted L should be selected. An insulator should be located between each support and the antenna, and the antenna will have to be swung clear of all nearby objects or else rigidly attached to them with insulators. The insulator near the house should be swung clear of the house on a rope or wire by a sufficient distance to insure against the possibility of the antenna rubbing against the house in windy weather. If one end is attached to a house and the other end to a tree, allowance should be made when tightening up the wire so that the probable swaying of the tree in windy weather will not break the wire. One way to get around this difficulty is to use a weight and pulley at the far end of the antenna. In any case the insulator should be located far enough out from the tree so that there will be no possibility of any of the branches coming into contact with the antenna wire.

Masts.—If no trees are available, wooden or metal masts can be erected without a great deal of difficulty or expense. The best metal mast would be a steel flagpole set in a concrete foundation and can be purchased from various manufacturers, but a fairly satisfactory substitute can be constructed from several lengths of wrought-iron pipe. The lower lengths should be of 2- or 2½-inch pipe and gradually taper in size upwards. That is, the first length would be 2½-inch, the second, 2-inch and so on. Unless extra heavy malleable iron couplings can be obtained it is usually best to have some machine shop make up a series of couplings of heavy construction with holes bored to fit the various sizes of pipe. These sleeve couplings need not be threaded but should make a tight fit for several inches on each length of pipe and holes should be bored for the insertion

of small pins to keep the couplings in place. The weak points of such a mast are the couplings and when it is erected a series of radiating guy wires should be attached at each joint so as to remove as much of the strain as possible. A series of guy wires should also radiate from the extreme top of the pole.

If a wooden mast is to be erected several two by fours of selected clear lumber may be used. The lengths should be bolted or clamped together in such a way as to produce a minimum amount of weakening at these points and the mast guyed at each joint just as in the previous case. The iron mast should be given a good coat of asphaltum or other preservative paint before erection and the wooden mast treated with several coats of spar varnish or other preservative paint.

Wire.—Either copper, aluminum or bronze wire may be used, the choice depending somewhat on local conditions. Aluminum is quite readily attacked by salt spray and chemical fumes and in this respect is not so good as copper or bronze, which are less subject to corrosion. Soft copper is unfortunately mechanically weak and not good where very long spans are to be erected. For long spans phosphor or silicon bronze or hard-drawn copper should be employed, and preferably in the form of a stranded cable. One standard size in wide use in commercial stations is composed of seven strands of No. 22 B. and S. gauge wire. Soft copper has lower resistance than any of the other types of wire, but in receiving circuits the additional resistance of the stronger wires is usually of small importance in comparison with other resistances in the circuit. Phosphor bronze and silicon bronze are usually hard drawn by a process similar to that employed in producing hard-drawn copper and which produces a very considerable increase in tensile strength. Heating the wire removes the effect of hard drawing and

makes it much weaker so care should be taken that soldered joints do not occur in parts of the wire subject to heavy tension. If joints are necessary in the span proper they should be made with special twisted sleeves such as are used in making joints in hard-drawn telephone and telegraph lines. If a soldered joint is considered essential the two ends of the wire can be slipped through the sleeves for 6 or 7 inches and the free ends connected together and soldered. The strain is thus put on the sleeve and at the same time the wire is actually soldered.

Copper-clad wire is well adapted for small receiving antennae. It has the advantage of fairly high tensile strength and good electrical conductivity at a reasonable price. It is composed of a steel core covered with a layer of pure copper and on account of the peculiar skin effect due to the high-frequency currents practically all of the current is carried on the surface of the wire and the steel core enters very little into the actual electrical conduction. Steel or iron wire without the copper coating is not to be recommended on account of the extraordinarily high losses which are incurred when it is used as a high-frequency conductor. Steel and iron are in quite general use on telephone and telegraph lines where direct or low-frequency currents are to be carried, but the skin effect induced by high-frequency currents enormously increases the resistance of iron or steel wires.

In choosing the location for an antenna, care should be taken that it is not screened by other conducting structures. It would, for instance, be very undesirable to locate an antenna in the "shadow" of a steel-framed building or in a location thickly surrounded by trees as a considerable proportion of the energy of the oncoming wave will probably be absorbed by the interfering structure and the signals weakened very much. However it is fortunate that during the winter when

radio transmission is at its best the trees are free from sap and usually frozen and this naturally greatly reduces the energy absorbed from the passing waves. The absorbing power of a hill is a rather uncertain quantity depending upon geological conditions; it is wise however to avoid, if possible, locations near very steep slopes as transmission may be seriously affected.

Grounds.—The type of ground connection employed will depend very largely upon the condition of the surface of the earth. If the earth is very moist the best type of ground connection is one consisting of a number of metallic stakes or rods driven into the ground directly under the antenna and located so as to cover the space directly under the antenna. These stakes should have copper wires soldered to them and after they have been connected together in a net work, a single lead should be brought to the radio apparatus. Where the ground is moderately dry on the surface it is well to see that the ground stakes actually penetrate into the layer of permanently moist soil which is usually found a short distance below the surface. Where underground water supply systems are available the ground connection may be made directly on to the water pipes without the necessity of constructing any elaborate ground system. Where the ground is extremely dry and no moist layer can be found at any reasonable depth below the surface, it is preferable to use a counterpoise. A counterpoise consists of a replica of the antenna erected directly under it and located only a short distance above the ground. No harm is done if the counterpoise system is larger and more extensive than the antenna system but it should be located as nearly under the antenna as possible and as near the earth as convenient. For receiving apparatus the counterpoise may be made of well-insulated wire and buried a few inches under the surface of the earth for the sake of mechanical protection, but care should be

taken that the insulation does not become defective and the counterpoise become partially grounded, for a partially grounded counterpoise is worse than none. If the counterpoise is located in such a position that it would interfere with traffic if located close to the ground, it may be elevated sufficiently high to clear pedestrians or teams, but it is better to keep it as close to the earth as possible. In any case the counterpoise must be well insulated from the ground. For transmission the counterpoise is much to be preferred in every case except where open water or marshy grounds are available, but the ground is of less importance in receiving equipment where the antenna circuit is usually of high resistance and the addition of small amounts of additional resistance is of relatively less effect. When the antenna is not in use it should be grounded so as to protect it against the effects of lightning and atmospheric electricity. This is best accomplished by means of a grounding switch located on the outside of the building and connecting the antenna to ground through a separate ground wire running down the side of the building and terminating on a stake driven into the ground. The Board of Underwriters, acting for the insurance interests, issue from time to time specifications governing the type and size of the grounding equipment required to conform to their regulations and details may be obtained from the local insurance agents.

Loop or Coil Antennae.—The type of antenna just discussed is affected by both magnetic and electrostatic components of the radio wave. In the case of loop or coil antennae the electrostatic component is neutralized and the action is due to the electromagnetic component of the oncoming wave. The loop antenna usually consists of a few turns of wire wound on a frame of relatively small dimensions. For reception from stations operating on 360 meters 15 turns wound on a frame 3 feet square would be approximately

correct. For longer waves more turns or a larger frame would be used. In the case of the previously discussed type of antenna, the directional characteristics are not very marked unless the horizontal length is very long as compared with the height, and then reception and transmission are best in the direction opposite to which the open end of the antenna is pointing. In all ordinary short-wave antennae this directional effect is quite small, and usually not noticeable. In the case of the loop antenna the directional characteristics are very marked and can be used to eliminate and receive stations at will depending upon the direction in which their signals travel. If a properly connected loop antenna is revolved around a vertical axis, the signal strength will vary according to the position of the loop, it will be strongest when the plane of the loop is pointing to the transmitting station and will fade out entirely when the loop is moved a quarter of a turn in either direction. The setting for zero signal is quite sharp but the point of maximum signal is not well defined as the intensity of the signal is only slightly altered by a considerable angular change when passing through the maximum point. In determining the direction from which signals are coming, the loop is revolved until the signal strength is reduced to a minimum and at this setting the waves are approaching the loop in a direction at right angles to its plane. Ordinarily there would be no indication from which of two directions the signals are approaching; for instance a given reading might indicate north or south. When the exact location of the sending station is desired, several independent readings are taken simultaneously from stations separated by some distance. The readings are collected and lines running in the directions indicated by the individual readings are drawn on a map through the known locations of the observing stations and continued until they meet. The point of meeting gives the

location of the unknown station. A series of radio compass stations equipped with loop receivers is maintained around each of the principal ocean ports by the U. S. Navy and ships entering into their range can be informed of their exact position in a very short time by simply calling the shore station and sending a series of signals. This system is obviously also useful in locating illegal radio stations.

The loop antenna can be used in place of the ordinary antenna by connecting one end to the lead normally connected to ground and the other end of the loop to the point normally connected to the antenna. A condenser has to be inserted in one of the leads since the loop has no condenser action like the elevated antenna. On account of the comparatively small portion of the wave which is intercepted by the loop as compared to that absorbed by the elevated antenna, the signal given by the loop is very much weaker than that produced by the elevated antenna. Usually from two to three additional steps of amplification are required in connection with the average loop antenna to give results comparable with those produced by elevated antennae.

The one disadvantage of the loop is the weakness of signal strength and it has a large number of advantages. Weak signals can often be received through powerful interference caused by nearby transmitting stations by turning the loop in such a direction that no signal is received from the nearby station without entirely losing the signal from the weak distant station. A loop also seems to pick up less disturbing noise and atmospherics in proportion to the signal produced than is the case with the elevated antenna and since the sound intensity can easily be brought up to any desired point with proper amplifiers this characteristic is of distinct advantage. Since high amplification is required with all loops, the best receiver to use is one which comprises several steps of radio-

frequency amplification, a detector, and several steps of audio-frequency amplification.

Transmission Phenomena.—The transmission of radio waves through the ether is the one weak and uncertain link in the system. It is never possible to accurately predict just what transmission conditions will exist at any given time; during certain periods signals may be very strong, and during other exactly similar periods, very weak. In general, however, it is found that signals are stronger during the night than during the daytime, that long-wave signals are less affected by day and night conditions, and that transmission conditions are much better in winter than in summer. The periods just around sunrise and sunset are frequently noticeable by sudden erratic changes in signal strength particularly in the case of long-wave long-distance transmission. The difference in day and night range is so pronounced that an amateur station operating on 200 meters may have ten times the range at night as compared with the daylight range. On the other hand signals from the high-powered long-wave transatlantic stations show only slight variation between day and night signals.

Such ranges as are obtainable on short waves during the daylight are fairly reliable and the signals do not vary greatly in intensity, while during the night the same station may be extremely strong one instant and totally inaudible the next. This phenomenon of fading, which applies alike to radio-telephone and telegraph signals, is not entirely understood, but is thought to be due to reflection and refraction phenomena in the upper layers of the atmosphere. Fig. 49 shows a transmitting station *A* and a receiving station *B* located exactly ten wave lengths apart. Part of the signal received at *B* consists of direct radiation parallel to the earth's surface and part is reflected downwards by the reflecting medium *R* after having been originally radiated

upwards. Radio waves being of exactly the same nature as light waves are reflected by conducting layers just as a mirror reflects light waves. We do not know what composes the reflecting layer but believe that it may be composed of dust or moisture-laden particles. If the distance between stations is exactly ten wave lengths, when a positive wave is being received at *B* another positive wave will be just leaving *A*. If the distance happened to be $9\frac{1}{2}$ or $10\frac{1}{2}$ wave lengths

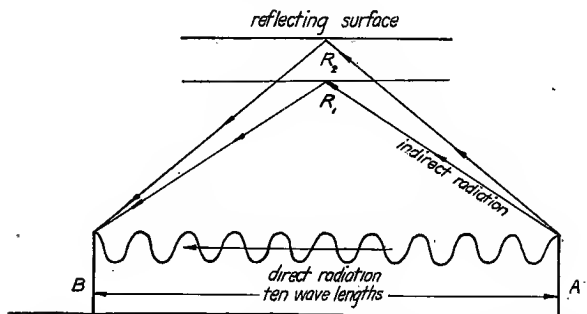

FIG. 49.—Diagram showing how fading phenomena may be produced by reflection from conducting layers above the earth.

then a negative wave would have been received at *B* while a positive wave was being radiated from *A*, or vice versa.

If the total effective distance measured from *A* to *R* and back down to *B* is an integral number of wave lengths a positive wave will be received at *B* when a positive wave is radiated from *A*, and the waves reaching *B* over the two routes will add together and produce a stronger signal than that due to either of the components. The reflecting layer is apparently in constant motion and if moving upwards will gradually increase the length of the reflected path until its effective length is increased by a half wave length. Now

the wave reaching *B* by the reflected route will have changed its phase with respect to the one reaching *B* by the direct route and the two waves will be of opposite polarity with respect to each other. If they happen to be equal in strength the two will cancel each other out and leave no signal at all. When the layer moves still higher, it will eventually increase the reflected distance by another half wave length and the two waves will again aid each other and this action will continue alternately increasing and diminishing the signal intensity as the two component waves move in and out of step. It will take three times as long for the reflecting layer to move a distance corresponding to a half wave length for a 600-meter wave as it will for a 200-meter wave and observation indicates that such is approximately the case, substantiating to some degree the original hypothesis. Certain investigators have assumed that clouds might be the basis of the reflecting surfaces, but observation seems to indicate that fading phenomena on clear nights are usually more pronounced than on cloudy ones.

Signals of all wave lengths are stronger during the colder than in the warmer months. This is particularly true in the case of short-wave signals which may vary from being totally inaudible in the summer time to strong signals in winter. The theory that green vegetation absorbs a large proportion of the energy of the wave in passing over the land seems substantiated from the results obtained from short-wave transmission. Each green tree and bush acts as a miniature receiving antenna and abstracts a minute proportion of the signal energy from each passing wave. This absorbing action is not present in the winter months for during this period the sap is absent and the trees frozen, making them non-conductors.

There seems to be an erroneous impression prevalent that the receiving range of a set is somehow connected with

the wave-length range; the longer the wave to which it may be tuned, the greater the distance over which signals may be received. This is a false idea as there is no direct relation between wave length and distance. It is true that where long distances are to be covered, long wave lengths are used, but there is a different reason for this. Long waves correspond to low-pitched notes while short waves are of higher frequency and correspond to high pitches. A penny whistle is very high-pitched but the factory steam whistle is deep-sounding and low-pitched, and the same general relations hold good in the case of transmitting stations. For transatlantic transmission waves around 10,000 meters in length are employed while for short-distance broadcasting 360 meters is more suitable. If it is desired to receive transatlantic communication, the receiving set will have to tune up to 10,000 meters, but its long wave-length range will not enable it to receive broadcasting any better, and unless it can be tuned down to low wave lengths, no broadcasting can possibly be heard.

“Atmospherics.”—The most disturbing element in radio transmission is the effect of the so-called “static” or “atmospheric” disturbances so frequently present. Very little is known regarding the origin of atmospherics but it is thought that they owe their origin to electrical discharges through the air somewhere above the surface of the earth. Their effect is to produce irregular sounds of no particular pitch in the telephone receivers and thus seriously interfere with the reception of weak signals. There are several different kinds of atmospherics which apparently result from different causes, a series of sharp clicks separated by a few seconds probably indicates lightning discharges accompanying a thunderstorm which may be many miles away, a steady rumble known as “grinders” is usually noted to a greater or less degree during the entire summer period although its

cause is not definitely known, while the approach of a snow-storm is frequently heralded by a peculiar hissing and squealing disturbance.

The elimination of atmospherics is a most difficult if not impossible matter. Tests have apparently shown that a large proportion of the atmospheric disturbances are propagated vertically, and this theory has been utilized in connection with directive reception with loops to eliminate some of their disturbing effects; however, the extensive apparatus required makes it beyond the possibility of most amateur stations.

Loose coupling between antenna and detector circuits in receivers where this is possible will cut down atmospherics in a greater ratio than it affects signals, and is about the only scheme that the amateur can conveniently employ. Loop antennae give relatively less atmospheric disturbance in proportion to signal strength than elevated antennae and may be employed to good advantage where effective amplification is possible. Insulated wires laid directly on the surface of the earth or buried a few inches may be used in place of the regular antenna for reception. While signals are much weaker than with the elevated antenna the atmospherics are reduced in still greater proportion with a consequent gain in readability.

If the receiving antenna is located near other electric wires a certain amount of disturbance will probably be experienced. If near an alternating-current transmission line a regular hum may be induced in the receiver. Trolley lines will frequently produce considerable noise particularly if the motors are not kept in first-class shape. These noises are best avoided by locating the antenna as far away from the disturbing line as possible and preferably at right angles to it. A single-circuit receiver of any type will pick up very much more

disturbance of this character than will the corresponding two-circuit receiver.

Where trees are allowed to grow up into the high-tension wires it frequently happens that the insulation becomes rubbed off and an arc is formed between the wire and the tree. This will produce a roar in the receiver and is almost impossible to eliminate. If the sparking wire is near by it will usually drown out all other signals. The power companies are usually quite willing to clear up such arcing grounds and will generally remedy this difficulty if the matter is called to their attention.

CHAPTER VIII

MISCELLANEOUS

Batteries and Battery Charging.—Although it is possible to use alternating current to light the filaments of transmitting tubes, it is usually not advisable to try to employ it for receiving tubes on account of the great difficulties experienced in eliminating the alternating-current hum. This is particularly difficult in sets employing high amplification, the hum induced in the detector tube, although perhaps not noticeable without amplifier, may be extremely annoying when amplified through several stages. Direct-current supply systems such as are employed in farm lighting plants and found also in the business districts of large cities may be used providing the commutator hum from the main generators can be eliminated. This may usually be accomplished with a condenser-inductance filter system as has been described in the chapter on tube oscillators. Since the voltage used on the tube is low compared with the line voltage of the system, some type of regulating resistance or rheostat must be provided to take care of the difference in voltages.

The most satisfactory system is to use some type of battery, as this will eliminate all noise. There are two general classes of battery applicable to this kind of service, (a) primary batteries and (b) storage batteries. The dry cell is the only type of primary battery in common use to-day and



A more elaborate cabinet mounting of the Aeriola Grand.

is not to be recommended for any type of continuous service requiring more than a small fraction of an ampere. It will satisfactorily supply the so-called "dry battery" tube which requires about two-tenths of an ampere, but the standard tube requiring about one ampere will soon exhaust it.

The production of electricity in any battery depends upon certain internal chemical reactions. As current is delivered by the cell a portion of the active chemical material inside the cell is changed over to another chemical form, and when all of the material is so changed we say that the battery is discharged. In recharging a primary battery we provide entirely new chemicals, which means that in the case of the dry cell the entire cell is discarded and a new one provided. In secondary or storage batteries we can convert the second compound back to its original form by passing current through it backwards. A storage battery does not store electrical energy but gets its ability to give back the electricity put into it by a storage of chemical energy.

Storage Batteries.—The electrical size of a storage battery is usually measured in amperehours. A 40-amperehour battery will theoretically deliver 40 amperes for one hour, 5 amperes for eight hours or 1 ampere for forty hours. Practically, the capacity is reduced as the current is increased. The same relations hold good in charging a battery except that on account of the internal losses it is necessary to put in a larger number of amperehours than we can expect to get out. The charging rates and times are usually given by the manufacturer on the name plate, in general the current values should not be exceeded but no harm will be done by charging for a longer time with a smaller current.

The length of time that any battery can be expected to supply a set can easily be computed. Receiving tubes require about 1 ampere each, hence a set employing a detector and two stages of amplification may be operated

continuously for thirteen hours on a single charge of a 40-amperehour battery.

There are two general types of storage battery in common use, the lead-acid type and the nickel-iron-alkaline type.

Lead-Acid Batteries.—The lead-acid type is more commonly used and has certain advantages and disadvantages. The advantages include high electrical efficiency and but slight variation of voltage during charge and discharge. Constancy of voltage is of considerable importance where critical soft detector tubes are used as it minimizes the adjustment necessary as the voltage drops due to discharge. Their disadvantages are great weight, liability of sulphuric acid electrolyte coming into contact with outside materials, and mechanical weakness of the glass or hard rubber containers. A lead cell may be easily ruined by being allowed to stand in a discharged condition.

The care of a lead battery involves charging as soon as possible after discharge and adding sufficient pure water from time to time to make up for that lost by evaporation and boiling away during charging. The state of charge is best determined by a battery hydrometer which measures the density of the acid electrolyte. The density of the electrolyte will vary in direct proportion to the amount of charge in the battery, the higher the specific gravity the greater the charge. The numerical values for different types of cell vary with the design and are usually given by the manufacturer. The battery should be charged as soon as the specific gravity has reached the lower point. In operating a battery in radio work it is generally quite simple to recognize the point at which it should be charged by the position of the adjusting rheostat on the detector tube, near the end of discharge the voltage falls off quite rapidly and the resistance of the rheostat must be correspondingly decreased.

It is of extreme importance that only the purest water

be used for refilling batteries as they may be completely ruined by slight traces of impurity. Distilled water is best and can be procured from the druggist or storage-battery service station, or very pure rain water which has not been stored in metallic containers and is free from other contamination may be used. On no account should water from city water mains, springs or wells be used.

Nickel-iron Batteries.—The nickel-iron battery, more generally known as the Edison battery, is far superior mechanically since it is mounted in electrically welded steel containers. The electrolyte consisting of a caustic solution is much less liable to cause damage with surrounding objects. It is practically impossible to electrically injure a battery of this type in ordinary operation. A periodic complete discharge which would ruin a lead battery actually benefits an Edison cell. It can be charged and discharged at almost any rate without injury. However, the electrical efficiency is low as compared with the corresponding type of lead battery and the voltage drops rapidly as it discharges. The voltage per cell averages a little over 1 volt as compared to a value of about 2 volts for the lead cell.

Plate Batteries.—The plate circuits of receiving tubes require voltages ranging from 20 to 100. These may be supplied by generators but are more often supplied by batteries. Generators give an undesirable hum which has to be eliminated by a series of filters as previously described. Both storage and dry cells are used for plate batteries. Certain commercial types of high-voltage storage battery are very satisfactory, but those of home-made construction are usually far from satisfactory. They are "messy," require constant attention and charging and in view of the excellent results obtainable with dry cells are hardly worth the additional bother.

Dry batteries for plate service should have what is known

as a long "shelf life." The current taken from a plate battery is so small that the battery usually goes bad from natural deterioration rather than from discharging. It seems rather difficult to combine long shelf life with the ability to deliver rather heavy currents for short periods of time as in the case with batteries intended for flashlight service and hence good plate batteries are built by a formula quite different from that employed in flashlight batteries. Care should be taken in the selection of plate batteries, some are merely assemblies of flashlight batteries while others are scientifically designed for long life in radio circuits. It is usually economy to buy the larger sizes of plate battery particularly when several tubes are operated from the same source. The standard plate battery unit is one composed of fifteen small cells connected in series and delivering $22\frac{1}{2}$ volts normally. Where higher voltages are required, several of these units may be connected in series. An exhausted plate battery will give very peculiar frying and hissing noises in the telephones which are very frequently mistaken for atmospheric disturbances. Exhausted batteries are best detected by the voltage test made with a voltmeter, the useful life usually having been reached when the reading drops to 17 volts.

Storage-battery Charging Apparatus.—Since most storage-battery charging stations are rather high in their rates for storage-battery charging, it is usually economical wherever possible to install charging apparatus.

The type of charging equipment will naturally depend upon the source of power available. Where direct current is available the battery can be connected in series with a suitable lamp resistance and charged directly from the line. Alternating-current circuits cannot be so used on account of the periodic reversal of the current, and some type of auxiliary apparatus has to be employed. Where a large

number of batteries are to be charged, a motor generator set is most economical. The motor is arranged to be operated from the alternating-current line, and in turn drives a low-voltage direct-current generator. For radio installations some type of rectifier is usually preferable on account of lower cost and additional simplicity. There are several types of rectifier, among which the mercury arc, the gas-filled hot cathode (Tungar and Rectigon), and the vibrating contact rectifier should be mentioned. Either of the first two types is very satisfactory and will operate equally well. The mercury arc must be started by hand and will be permanently stopped if the power is momentarily interrupted, while the second type requires no hand starting and will operate continuously as long as the voltage is available. The vibrating contact rectifier is not quite as satisfactory in its present stage of development as the other two types since it requires some adjustment for best operation.

Wavemeters.—Instruments used to determine the length of radio waves are called wavemeters. They consist essentially of an electric circuit containing both inductance and capacity, either or both adjustable and whose values are accurately known. The additional apparatus required depends upon the particular use to which the wavemeter is put.

Measurement of Transmitter Wave Length.—In order to measure the wave length of a transmitting set some indicating device must be used in connection with the wavemeter. This may consist of a sensitive high-frequency ammeter connected in series with the circuit, a rarefied gas discharge tube connected across the terminals of the condenser, or a crystal detector and telephone receiver connected to a condenser terminal, depending upon the strength of the transmitting set. The wavemeter inductance coil is brought near some part of the antenna circuit of the transmitter and

the wavemeter adjusted until the indicating device shows a maximum. This point will be indicated by a maximum deflection of the ammeter needle, the most intense glow in the tube, or the loudest sound in the telephones. Some wavemeters have the readings in wave length engraved directly upon the scale of the variable condenser or inductance and by noting the reading at which the maximum effect was obtained the wave length may be directly determined. In other cases it will be necessary to refer to the calibration chart which shows the relation between wave lengths and scale readings. The theory is that the maximum effect will be produced when the natural frequency of the wavemeter circuit is the same as that of the wave to be measured, and thus the unknown frequency can be computed by knowing the capacity and inductance of the wavemeter circuit.

When measuring the wave length of continuous wave transmitters such as tube telegraph and telephone sets care must be taken that the coupling between the wavemeter and the set is not too great as the tuning is extremely sharp and a change of one or two degrees in the setting of the instrument may be sufficient to throw the pointer off the end of the scale and burn out the instrument if the wavemeter is too near the transmitting set.

Receiving Circuit Calibration.—For measurements with receiving apparatus the wavemeter is usually arranged to emit feeble electric waves of known length which are received on the receiver just as waves coming in on the antenna. To find the adjustment on the receiver for any given wave length, set the wavemeter to send out signals of this frequency and then adjust the receiver until the loudest sound is heard in the telephones. The wave length of any distant transmitting station can be measured by adjusting the receiving set to receive the signal from the station with maximum intensity and then without disturbing the receiver

adjustment vary the wave sent out from the wavemeter until the loudest sound is heard in the telephones when the setting on the wavemeter will naturally give the wave length of the distant station. In order to emit signals a high-

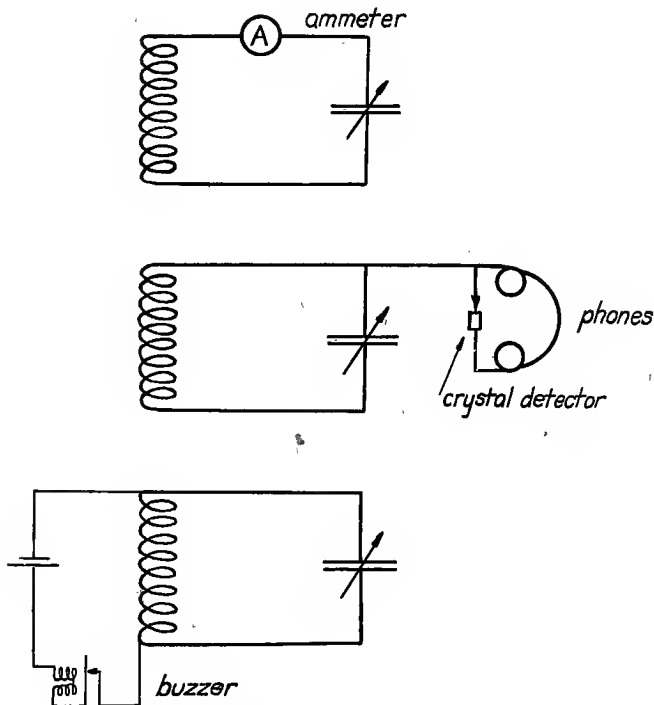

FIG. 50.—Typical wavemeter connections.

pitched buzzer is used and the usual connection is shown in Fig. 50. The rapid interruption of the battery current each time the contact on the buzzer is broken sets up pulses of battery current through the inductance coil of the wave-

meter and this sets the circuit into oscillation at its own natural wave length just as plucking a mandolin string produces a sound whose pitch is determined by the tension and size of the string.



FIG. 51.—Kolster decremeter and wavemeter.

The Kolster Decremeter and Wavemeter illustrated serves a number of purposes; measurement of the wave length of a transmitter can be made with the high-frequency ammeter or the crystal detector and telephones, while the

buzzer supplied by the small dry battery attached to the side of the instrument enables it to send out waves of known wave length for receiver calibration. The measurement of decrement from which the instrument gets its name is of interest principally in the case of spark transmitters used for radio telegraphy and is made to determine the sharpness with which a given spark station may be tuned in or out. The Government regulations specify certain requirements in this regard to prevent undue interference with other stations. There are three removable coils supplied with the instrument and the condenser is continuously variable with values of wave length corresponding to different settings of the condenser engraved directly upon the condenser dial.

The Selection of Apparatus for Broadcasting Reception.—

Just as the distance over which a sound may be heard depends upon the loudness of the sound, the acuteness of the listener's ear, and the amount of other noise present, the range of any radio telephone broadcasting station is dependent upon similar factors. Up to a distance of 150 to 200 miles from such first-class stations as Pittsburgh, Newark, Schenectady and Detroit, the problem is one involving almost entirely the acuteness or sensitivity of the receiving apparatus. Beyond this distance the signals are often seriously interfered with by outside noises such as "atmospherics" and noises produced by local electrical apparatus, so that the question is no longer one of sensitivity but of selectivity.

It is very difficult to predict with any degree of certainty just what any given installation will do on account of the great difference in the receptive powers of different antennae. Under average conditions with an antenna about 40 feet in height and around 150 feet long it should be possible

to obtain satisfactory results with either a single or coupled circuit type of crystal detector receiver from any station of the class mentioned above up to distances or about 30 miles. Satisfactory results have been attained with are this equipment at much greater distances but these results somewhat exceptional.

Where greater sensitivity is desired for locations up to 100 miles some type of vacuum tube detector is the most desirable. The non-regenerative circuit is very much less sensitive than the regenerative circuit and care should be taken when purchasing apparatus to find out just what circuit is employed as certain of the non-regenerative sets look almost exactly like the better regenerative receivers.

Every tube receiver requires two batteries or their equivalent, one to light the filament and the other to supply a direct-current voltage around 22 volts for the plate. If standard tubes employing tungsten filaments are used, it will probably be necessary to purchase a storage battery for the filament supply. One set of this character uses a special tube with low filament consumption and this tube may be supplied from a single dry battery.

Increase in sensitivity beyond this point is obtained by the addition of one or more steps of amplification. If an outside antenna of usual dimensions is used a regenerative receiver and two-stage audio-frequency amplifier will usually receive about all that can be received as such a set will amplify the disturbing noises up to a point where they interfere with the distant signals and will thus be capable of reproducing any signals that can be heard above the local atmospherics and other disturbing noises.

Indoor Antennae.—It is possible to erect indoor antennae and obtain approximately the same results as would have been obtained with the same antenna erected outside the

building provided that the construction does not shield the antenna from the incoming waves. Theoretically if the building contains no metal of any kind the signals should be just as strong with an indoor antenna as they would be with an outdoor one of the same dimensions. This condition is seldom found in practice as nearly every structure has some metallic circuits such as electric wires, water pipes, etc., but if they do not extend above the antenna their effect is not great.

Equipment using Loop Antennae.—Loop antennae can be substituted for outside antennae with very satisfactory results if sufficient amplification can be provided. As a general rule a loop of average dimensions requires about two or three stages of additional amplification to produce the same signal as would be obtained from an average-sized elevated outdoor antenna. Where extremely high amplification is necessary it is usually necessary to utilize both radio- and audio-frequency amplification. It is possible to obtain completely self-contained receivers consisting of loop antenna, radio- and audio-frequency amplifiers, detector, and loud speaker assembled in a single cabinet. This makes an ideal combination as the set can be located almost anywhere as it is self-contained and requires no outside antenna. There are certain advantages of the loop as compared with the outside antenna which have been previously discussed which can be realized in this type of receiver. The principal disadvantages are the high initial cost, heavy drain on the storage batteries and rather complex circuits involved.

Loud Speakers.—Loud-speaking telephones are desirable where several persons listen simultaneously. They require however from one to two additional stages of audio-frequency amplification with the last stage preferably employing

the "push-pull" connection and with power tubes substituted for ordinary receiving amplifier tubes. The electrodynamic type of loud speaker requires a separate circuit from the storage battery to energize the electromagnet in the apparatus.

INDEX

A

- Airplane generator, 35
- Alexanderson alternator, 12
- Alternation, 6
- Alternator transmitters, 12
- Amplification
 - constant of tube, 21
 - mechanical, 20
- Amplifiers, 86
 - audio-frequency, 86
 - power, 42
 - push-pull, 96, 128
 - radio-frequency, 90
- Amplifying transformers, 88, 90
- Amplifying tubes, 89
- Antenna
 - coil, 107, 127
 - connections, 45
 - construction, 103
 - effect of loading, 59
 - elevated, 100
 - equivalent circuit of, 58
 - indoor, 126
 - location, 105
 - loop, 107, 127
 - masts, 103
 - theory, 98
 - types of, 102
 - wire, 104

- Atmospherics, 113
 - elimination of, 114

B

- Baldwin receiver, 93
- Batteries, 116
 - dry, 117, 119
 - plate circuit, 119
 - primary, 116
 - storage, 117
 - lead-acid, 118
 - nickel-iron, 119
- Battery charging, 120, 121
- Broadcasting
 - selection of apparatus for, 125

C

- Choke coil, radio-frequency, 41
- Circuits
 - receiver—see under Receiver
 - transmitting tube, 44
- Compass, radio, 109
- Condenser
 - connections, 33
 - filter, 41
- Conductor
 - definition, 14
- Coil antenna, 107

Counterpoise, 106

Current

alternating, 6

direct, 6

high-frequency, 7

plate, 18

saturation, 18

Cycle, 6

D

Decremeter, 124

DeForest, Dr. Lee, 19

Detector

crystal, 60, 61

"soft" tube, 72

vacuum tube, 67

with grid condenser, 68

without grid condenser, 70

Disturbances, 113, 114

Dynamotor, 34

E

Electricity

negative, 16

positive, 16

Electrons, 14

mutual repulsion of, 17

value of, 15

Ether, 98

waves, 99

Evaporation

of electricity, 15

of water, 15

F

Fading, 111

Feedback

coupling, types of, 28, 29, 30, 31

principle, 27

Filaments

oxide-coated, 21

tungsten, 15, 21

Filter

condensers, 41

systems, 37

Fleming valve, 16

rectifier action of, 17

Frequency

chart, 8

definition, 6

formula, 32

radio, 7

tube oscillation, 28, 32, 33

G

Generators

direct-current, 33

dynamotor, 34

high-voltage, 35

location of, 44

Goldschmidt alternator, 12

Grid electrode, 19

action of, 24

Ground connection, 106

counterpoise, 106

H

Heat waves, 8

Howling telephone, 27

I

Inductance

formula, 58

Ionization by collision, 39, 74

J

Joly-Arco alternator, 12

- L
- Light waves, 8
 Loop antennæ, 107
 Loud speakers, 92, 93, 127
- M
- Magnetic coupling, 29, 33
 Magnetic modulator, 13, 48
 Master oscillator, 43
 Masts, 103
 Modulation
 antenna control, 47
 "constant current," 51
 grid circuit, 52
 plate circuit, 50
 tube outfit, 50
 Modulator
 magnetic, 13, 48
 systems, 47
 Molecule
 activity of, 14
- O
- Oscillations
 frequency of, 28, 32, 33
 production of, 27
 Oscillator
 master, 43
 vacuum tube, 24
- P
- Plate voltage, usual values of, 33
- R
- Radio compass, 109
 Receiving circuit calibration, 122
 Receiving equipment, 55
- Receivers
 Baldwin, 93
 crystal detector
 single circuit, 61
 "loose coupler," 66
 electrodynamic, 94
 loud-speaking, 92, 93
 telephone, 4, 94
 tube
 non-regenerative, 67-75
 regenerative, 75-85
- Rectifiers
 cold cathode, 39
 double-wave, 36
 electrolytic, 39
 hot cathode, 36
 internal action of, 37
 single-wave, 36
 systems, 36
- S
- "Soft" tubes, 72
 Spark transmitters, 10
 Steam hammer, 24
- T
- Telephone
 diaphragm, 2
 radio, 4
 receivers, 4, 92
 systems, comparison of, 1
 transmitter, 1
 "Tickler" coil, 78, 83
 Transmission phenomena, 98, 110
 Tubes
 amplifier, 89
 "soft," 72
 Tuners, 60

	W	
Wave-length		Waves— <i>Continued</i>
antenna, 101		heat, 8
formulae, 32, 55, 56		light, 8
measurement of, 121, 122		sustained, 9
relation of, to range, 112		Wire
Wavemeters, 121		antenna, 104, 105
Waves		"litzendraht," 48
damped, 9		
electromagnetic, 98		X
		X-rays, 8

