

THE AMERICAN

ELEVATOR AND

GRAIN TRADE



Printed in U. S. A. Entered as second-class matter June 26, 1885, at the Post Office at Chicago, Illinois, under Act of March 3rd, 1879. Established 1883

PUBLISHED BY
Mitchell Brothers Publishing Co.

A MONTHLY JOURNAL DEVOTED TO THE ELEVATOR AND GRAIN INTERESTS.

One Dollar Per Annum
SINGLE COPIES, 15 CENTS

VOL. XLII

431 South Dearborn Street, Chicago, Ill., November 15, 1923

NO. 5

WE ARE PROGRESSIVE ENOUGH
TO BE AGGRESSIVE FOR YOU

McKENNA & DICKEY
Grain

80 BOARD OF TRADE
CHICAGO

For your
Business Sake
Communicate

**LIGHTNING IS THE LARGEST
DESTROYER OF ELEVATORS**

COST OF PROTECTION SAVED IN REDUCED INSURANCE

Govt. State Municipal and Industrial Plants
Equipped with our 25-year Guaranteed System-

THE ARROW CONDUCTOR CORP. CHICAGO

"THE MARKET'S UP!"

How Soon Will You Know?

Find Out Instantly With

RADIO

It means money to you. Market reports every half hour through the day—FREE!

CATCH THEM—THEY'RE YOURS

Baseball, Football Scores, Time Signals, Lectures, the Opera, Wonderful Concerts—

A MILLION THINGS

Out of the air with this wonder worker

EHRLER-RADIO

30 N. Dearborn St. CHICAGO

Radio Sets and Accessories are Useful Gifts

"When You Think of Radio Think of Ehrler"

FEED SYSTEM ENGINEERING

for Feed Plant Construction and Equipment
Feed Formulas & Manufacturing Methods

S. T. EDWARDS & CO. 110 S. Dearborn St. CHICAGO

THE ILLINOIS SEED CO.

GRASS SEEDS FIELD

BUYERS CHICAGO SELLERS

Ask for Samples

Mail Samples for Bids

TIMOTHY, CLOVERS, ALSIKE, ALFALFA, MILLETS, RED-TOP, BLUEGRASS, SEED GRAIN, GRAIN BAGS, Etc.

The Emerson Dockage Tester

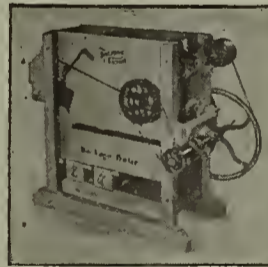

Positively determines all foreign matter in your samples—often pays for itself on one car of grain—the Tester used in Federal Grain Supervision Offices. Made in both hand and electric motor driven styles.

Made by

EMERSON MANUFACTURING COMPANY

1701 Madison St. N. E., Minneapolis, Minn.

COURTEEN SEED CO.

Specialize in all

GRASS AND FIELD SEEDS

SHIPPERS. Send Samples for Bid.

BUYERS. Ask for samples and prices.

MILWAUKEE, WISCONSIN

PREDOMINATOR

**GRAIN BELTING
ELEVATOR and CONVEYOR**

Ask for Our Salesman to Call

Hamilton Rubber Manufacturing Co.

118 So. Clinton Street

CHICAGO, ILL.

Select a Steel Post that is Different and Better— *Ankorite* Studded "T" Post



DON'T handle a post just like every other dealer in town is selling—select one with distinctive features that eliminates competition. Here are two exclusive features that make the Ankorite Studded "T" Post a real profit builder.

New Snap-On Fastener

The simplest, most practical wire fastener you ever saw. The workman just strings the wires and snaps the fasteners in place as he goes—then walks along the fence and bends over the legs of the fasteners with a pair of pliers. They hold.

An Anchor Plate Clamp That Never Gets Loose

Fastened with a heavy U-shaped steel bar, clamped firmly around the post. No holes in the post to weaken it; no rivets to pull loose in driving.

When buyers want these important features they'll have to come to you to get them. Your Ankorite franchise is liberal and profitable. Write for details.



The Snap-on fastener

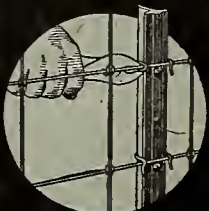

Showing method of fastening



CALUMET STEEL COMPANY 208 SO. LA SALLE ST. CHICAGO ~ ~ ILL.

SEND US YOUR DRAFTS

Collections Remitted
For Promptly

The Second National Bank

of

TOLEDO, OHIO

CAPITAL, \$1,000,000

SURPLUS AND PROFITS, \$2,800,000

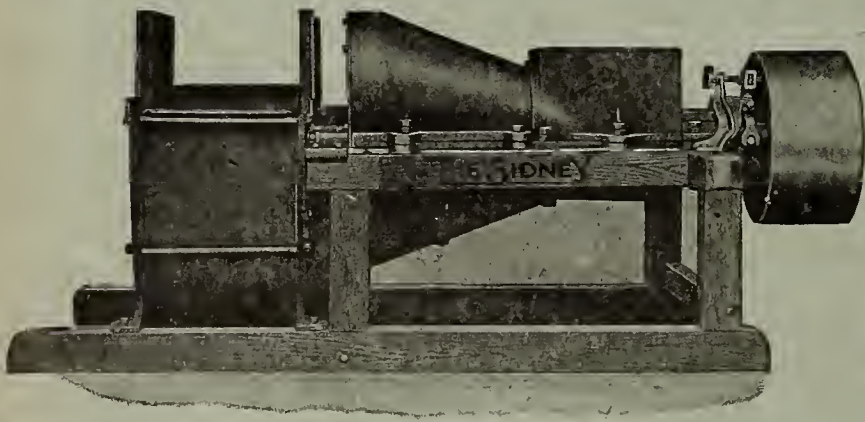

The Sidney Combined Sheller and Boot

The Sidney Combined Sheller and Boot without take-ups on boot is a combination of the regular Sidney Sheller and Standard Cast Iron Elevator Boot requiring no expensive hopping and eliminates deep tank or pit under elevator. It is guaranteed to work successfully on corn in any condition.

Other Specialties for the Grain Trade Are:

- The Sidney Double Shoe Corn and Grain Cleaner
- The Sidney Ball Bearing Safety Man Lift
- The Sidney Style B Grain Drag

We Furnish Complete Grain Elevator Equipments

Send for Catalog

THE SIDNEY GRAIN MACHINERY CO.
SIDNEY, OHIO



SILENT CHAIN DRIVES

Operate with maximum efficiency over short centers. This fact alone enables A Morse Silent Chain Drive to quickly pay for itself in the space it makes available for productive uses.

MORSE CHAIN CO., ITHACA, N. Y.

There is a Morse Engineer near you

- | | | |
|------------------|----------------------|----------------------|
| Atlanta, Ga. | Denver, Colo. | Philadelphia, Pa. |
| Baltimore, Md. | Detroit, Mich. | Pittsburgh, Pa. |
| Boston, Mass. | Kansas City, Mo. | San Francisco, Cal. |
| Charlotte, N. C. | New York City. | St. Louis, Mo. |
| Chicago, Ill. | Minneapolis, Minn. | Toronto, Ont., Can. |
| Cleveland, Ohio | Montreal, Que., Can. | Winnipeg, Man., Can. |

WE CAN NOW SUPPLY

Elwood's Grain Tables

Show the value of any number of bushels or pounds of WHEAT, RYE, OATS, CORN OR BARLEY at any given price from 10 cents to \$2.00 per bushel. One of the most useful books ever offered to millers. Indorsed by prominent millers and grain dealers. Bound in cloth, 200 pages. Mailed on receipt of price.

\$2.00

Mitchell Brothers Publishing Co.
431 S. Dearborn St. Chicago, Ill.

EVERYTHING YOU NEED For Your Corn Meal and Feed Plants

We have, for the past Sixty-three years, manufactured a full and complete line of machinery for Flour, Corn, Feed and Cereal Mills and Grain Elevators. Also Power Transmission Machinery.



Victor Corn Sheller

Victor Corn Sheller

The Victor Corn Sheller is the STANDARD sheller of the world. It is made to shell only, and is particularly adapted to elevators and feed mills where it is desired to shell corn in the basement, and separate and clean it in the upper part of the house. It is made in seven sizes, ranging in capacities from 60 to 1,500 bushels per hour.

We also make a pitless corn sheller, in five sizes, that will discharge directly into the elevator boot, thereby obviating the necessity of a deep pit or tank under your house.

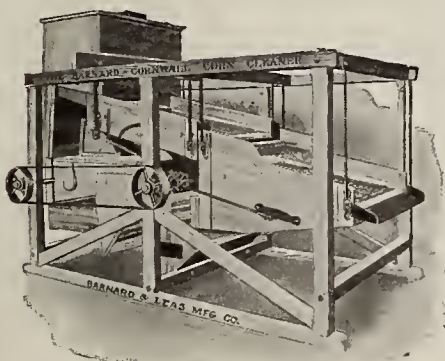

Barnard-Cornwall Corn Cleaner

Barnard-Cornwall Corn Cleaner

The Barnard-Cornwall Corn Cleaner—equipped with our Patent Finger Sieve is the most practical sieve corn cleaner on the market. It removes, without clogging, all cob ends, pieces of cob, chaff, silks, husks, shrunken grains and light, broken pieces of corn, leaving the corn absolutely clean. It is made in six sizes—ranging in capacities of 175 to 2,000 bushels per hour. The machine is dustless, light running and durable, saves the screenings for feed and cleans the corn thoroughly in one operation.

We also make the Little Victor Corn Cleaner—a small capacity machine. Also the Barnard-Moline Improved Single and Double Screen Dustless Corn Cleaners—rolling screen type.

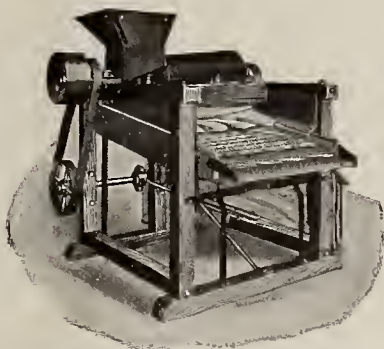

Little Victor Combined Corn Sheller and Cleaner

Combined Corn Shellers and Cleaners

The Little Victor Combined Corn Sheller and Cleaner, equipped with our Patent Finger Sieve, to prevent clogging, is especially designed to meet the requirements of those wanting a machine of small capacity, yet strong and durable. It shells and thoroughly cleans the corn in one operation. It is made in two sizes—60 and 125 bushels per hour. The small size can be placed in a small space 4'9" x 4'5"; the large size, 5'3" x 7'.

We also make the Victor Combined Corn Sheller and Cleaner—rolling screen type.

Barnard-Moline Roller Feed Mills

We manufacture a full and complete line of Roller Mills—Three Roller, One, Two and Three-pair-high and Combined Six Roller Mills—for grinding Corn, Wheat, Oats, Barley, Fine Meal of all kinds, Coarse Corn Meal, Feeds of all kinds, Wheat for Graham, Rye and other small grain. Made in various sizes with either chain-oiling or ball bearings.

We also make a full line of Reels and Sifters for bolting corn meal, and Feed Mixers for mixing various kinds of feeds.

Let Us Quote on Your Requirements

BARNARD & LEAS MFG. CO.

"Builders of High Grade Milling Machinery Since 1860"

MOLINE, ILLINOIS, U. S. A.



Barnard-Moline Light-Running Three Roller Feed Mill

INDIANAPOLIS

Indianapolis—Your Market—A Three Times Greater Grain Market

Indianapolis, the center of grain centers, is known today as one of the most important, rapidly growing grain and hay markets in the country. Receipts of grain during the last ten years have nearly trebled in volume, due to the advantages its geographical location offers to the grain and hay producing and consuming sections of the country, its splendid railroad facilities assuring prompt returns on shipments, its large local consumption of grain by its corn and flour mills and its manufacturing industries, its increased elevator storage and drying equipment, its adequate weighing facilities and efficient inspection department. This has made Indianapolis more and more important each season for shippers and buyers of grain, hay and feed.

Movement of Grain and Hay During the Year 1922

	Receipts	Shipments
Corn	21,274,000 bushels	13,588,800 bushels
Oats	9,893,000 bushels	7,659,000 bushels
Wheat	3,301,600 bushels	1,538,500 bushels
Rye	703,200 bushels	368,000 bushels

The following Receivers and Shippers are members of
Indianapolis Board of Trade

<p>Bert A. Boyd Grain Co. The Indianapolis Commission House "Consignments Our Hobby" We Never Buy for Ourselves—We Always Sell for You</p>	<p>JAMES E. BENNETT & CO. GRAIN, STOCKS, COTTON MEMBERS New York Stock Exchange Chicago Board of Trade and other leading exchanges. Cash Grain Shipments Solicited Indianapolis branch at 718 Board of Trade</p>	<p>H. E. Kinney Grain Co. COMMISSION—BROKERAGE</p>
<p>The Cleveland Grain Co. OPERATING FIVE TERMINAL ELEVATORS Mighty Good Consignment Service Ed. K. Shepperd, Manager</p>	<p>The Lew Hill Grain Company Incorporated Capital Stock \$50,000 GRAIN COMMISSION, BROKERAGE Phone Main 3886</p>	<p>Lamson Bros. & Co. GRAIN, STOCKS AND PROVISIONS Members of New York Stock Exchange, Chicago Board of Trade and other Commodity Markets</p>
<p>The Bingham Grain Company Receivers and Shippers of GRAIN</p>	<p>HART-MAIBUCHER CO. GRAIN COMMISSION and SALES TO ARRIVE SERVICE - EFFICIENCY - COURTESY</p>	<p>C. D. Menzie Grain and Brokerage Co. SALES MADE TO ARRIVE</p>

WELLER EQUIPMENT

The Better Kind of Grain Handling Machinery



NORTHERN CENTRAL ELEVATOR, BALTIMORE, MD.

Weller made products are sold on the basis of quality. Installed in your elevator they will help you to operate at full capacity at the lowest cost for upkeep. Frequent shutdowns and waiting for repairs dissipate your profits so why not specify

WELLER MADE MACHINERY

Made by men who know its application and the conditions under which it is to operate. It proves its merit because quality is built into it.



MARINE LEG
NORTHERN CENTRAL ELEVATOR
BALTIMORE, MD.

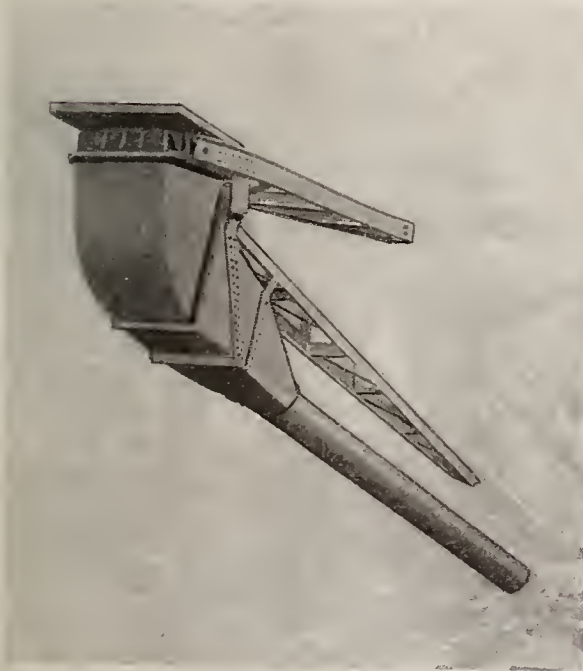

DOCK SPOUTS
NORTHERN CENTRAL ELEVATOR
BALTIMORE, MD.

WE MAKE

- | | |
|------------------|-----------------|
| Apron Conveyors | Elevator Spouts |
| Belt Conveyors | Loading Spouts |
| Drag Conveyors | Dock Spouts |
| Pan Conveyors | Chain |
| Mixing Conveyors | Sprockets |
| Spiral Conveyors | Grain Cleaners |
| Trippers | Grain Driers |
| Bucket Elevators | Truck Dumps |
| Elevator Buckets | Wagon Dumps |
| Elevator Boots | Track Hoppers |
| Elevator Casing | Power Shovels |
| Elevator Heads | Car Pullers |
| Sack Elevators | Rope Drives |
| Barrel Elevators | Gears |

Power Transmitting Machinery
Coal and Ash Handling Machinery

Send Us a List
of Your Requirements
We Will Quote Prices
WELLER MACHINERY
Is Adapted for Use in Large or
Small Elevators

WELLER MFG. CO.

Main Office and Works,

1820-1856 N. Kostner Ave.

Chicago, Ill.

SALES OFFICES:

NEW YORK

BOSTON

BALTIMORE

PITTSBURGH

DETROIT

SAN FRANCISCO

CINCINNATI

THE GATEWAY TO THE SOUTH AND EAST

Has the "square deal" plugging system for hay.

Has reconsignment and transit privileges and other favorable points which insures most successful handling of grain or hay shipments.



Home of the Cincinnati Grain and Hay Exchange

Is the terminal point for 200,000 miles of railways and therefore a convenient shipping point for the country dealer, and local buyers are enabled to distribute all products quickly and to best advantage. Has weighing and inspection service second to none and up-to-date grain and hay merchants constantly safeguarding their patrons' interests.

Those are just a few of the reasons why you should ship your Grain and Hay to Cincinnati. Ship to any of the following responsible grain and hay firms, all members of the

Cincinnati Grain & Hay Exchange

MUTUAL COMMISSION COMPANY,
Strictly Commission

DE MOLET GRAIN CO., Grain and Hay

A. C. GALE & CO., Shippers of Choice
Milling Wheat

CLEVELAND GRAIN & MILLING CO.,
Grain

FITZGERALD BROS. CO., Grain and Hay

THE CURRUS GRAIN CO., Grain & Hay

SCHOLL GRAIN CO., Grain Exclusively

PERIN, BROUSE, SKIDMORE GRAIN &
MILLING CO., Grain, Hay, Feed

EARLY & DANIEL CO., Hay, Grain, Feed

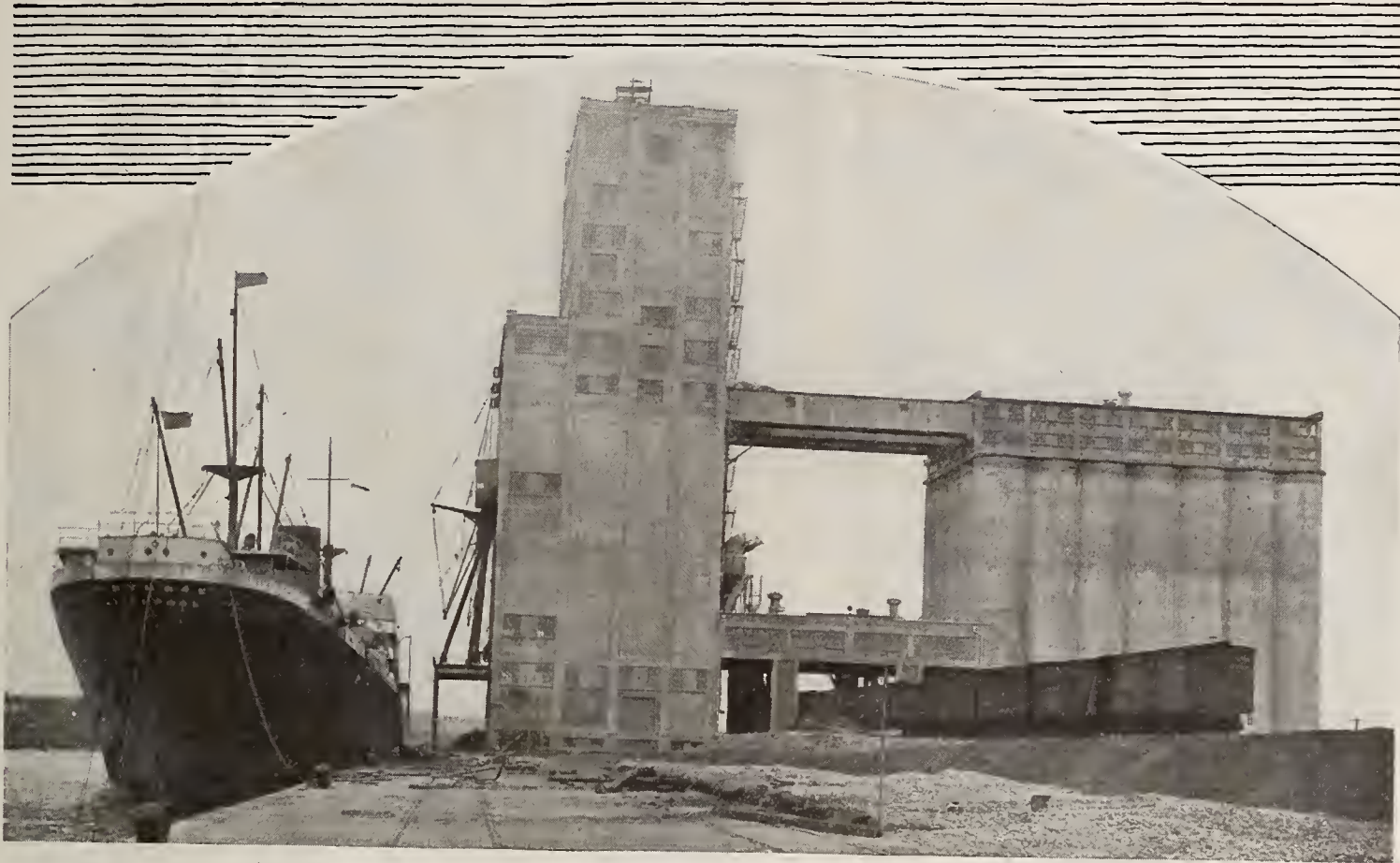

A "Known Quantity" in Modern Grain Elevator Equipment

WEBSTER service to grain elevator engineers and builders is based on an intimate knowledge of the grain elevator business coupled with an unusual ability to meet its particular conditions. This service has years of background, experience, and development behind it. As a result Webster Grain Handling Equipment is a known quantity in modern elevator practice regardless of whether the equipment includes Marine Legs, Belt Conveyors, Elevators, Loading Hoppers, Spouting, or Power Transmission Machinery.

Engineers and Builders of Grain Elevators and Mills will therefore find it worth while to work with Webster Engineers on their grain handling problems. They will help you in selecting suitable equipment to meet your particular requirements. This service is at your disposal.

THE WEBSTER MFG. COMPANY

4500-4560 Cortland Street, CHICAGO

Branch Offices

BOSTON 902 Oliver Bldg.
BUFFALO 572 Ellicott Square
CINCINNATI 1914 Union Central Bldg.
CLEVELAND 509 Sweetland Bldg.
NEW YORK 90 West Street
PHILADELPHIA 719 Commercial Trust Bldg.

Factories

CHICAGO, ILLINOIS TIFFIN, OHIO

Agencies and Representatives

Atlanta, Ga. Fulton Supply Co., 70 Nelson St.
Baltimore, Md. H. W. Faunt LeRoy, 523 Calvert Bldg.
Birmingham, Ala. G. R. Mueller, Brown-Marx Bldg.
Denver, Colo. C. L. Dean, 1718 California Ave.
Detroit, Mich. Palmer-Bee Co., 2778-2794 E Grand Blvd
Knoxville, Tenn. Webster & Co., Holston Bank Bldg.
Louisville, Ky. E. D. Morton & Co., 516 W. Main St.
Memphis, Tenn. E. C. Atkins & Co., Malne & Butler Sts.
Milwaukee, Wis. W. Clasmann Co., 620 Wells Bldg.
New Orleans, La. Globe Supply & Machinery Company,
625-627 S. Peters Street.
Pittsburgh, Pa. Dempey-Degener Co., 708 Penn Ave.
Salt Lake City, Utah, L. W. Mendenhall, 517 McIntyre
Building.
Salt Lake City, Utah Galigher Machinery Co.
Seattle, Wash. The Brinkley Company, 651 Alaska St.
Vancouver, B. C. B. C. Equipment Company, Ltd.,
613 Bank of Nova Scotia Bldg.

Canadian Factory - Sales Office: WEBSTER - INGLIS, LIMITED, 14 Strachan Ave., Toronto, Ont.

MACDONALD ENGINEERING CO.

CONSTRUCTING ENGINEERS

Chicago 53 W. Jackson Blvd. New York 90 West St. San Francisco 149 California St. Toronto, Ont. C. P. R. Building.

**DESIGNERS AND BUILDERS
OF**

**GRAIN ELEVATORS, FLOUR MILLS, WAREHOUSES,
COLD STORAGE PLANTS, COAL STORAGE, ETC.
SEND US YOUR INQUIRIES**



400,000-BUSHEL ELEVATOR

BUILT FOR
POSTUM CEREAL CO., BATTLE CREEK, MICH.
"THERE'S A REASON"

FOLWELL-AHLKOG CO.

Engineers and Contractors

*Designers and Builders
OF*

**Grain Elevators, Flour Mills, Industrial Plants, and other
Engineering Works**

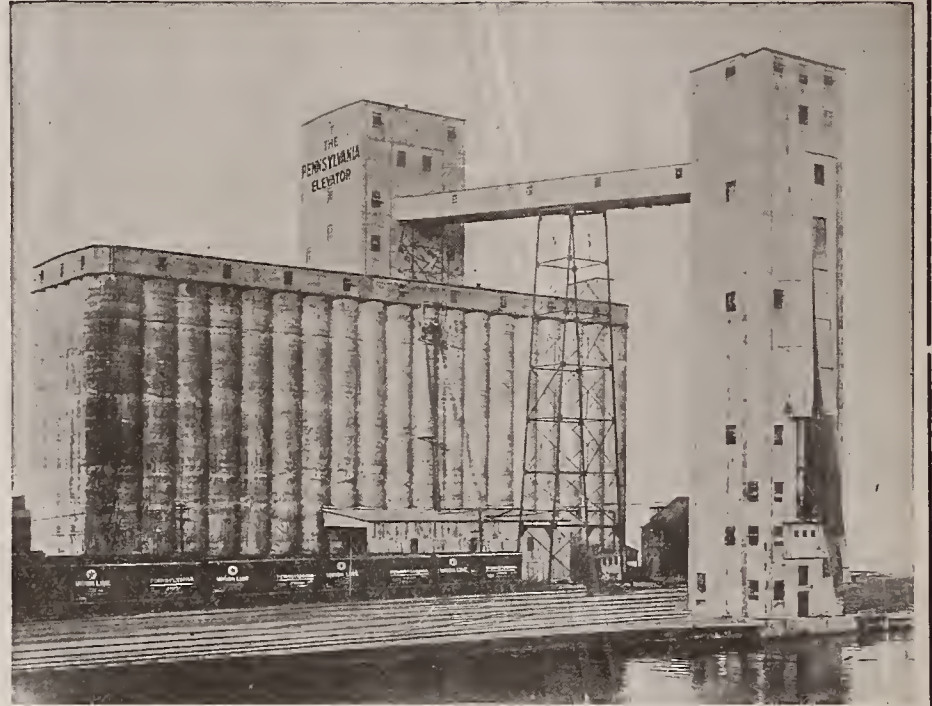

PENNSYLVANIA RAILROAD COMPANY ELEVATOR, ERIE, PA.

1,250,000-bushel Concrete Workinghouse and 25,000-bushel Marine Tower. Reinforced Concrete. Latest improvements. Write us for designs and estimates.

323 N. MICHIGAN AVE., CHICAGO, ILL.

**PETERBORO, ONT. PLANT
THE QUAKER OATS COMPANY**

DESIGNED AND BUILT BY
LEONARD CONSTRUCTION CO.



LEONARD CONSTRUCTION COMPANY

**ENGINEERS and
CONSTRUCTORS**

37 SO. WABASH AVE.
CHICAGO

51 MAIDEN LANE
NEW YORK

We Invite Your Inquiries

**PROTECT YOUR INVESTMENT
FROM FIRE BY UTILIZING
REINFORCED CONCRETE**



Reinforced concrete construction typifies the truest form of economy in that it provides the most modern form of buildings and reduces the fire-risk to a minimum.

**FLOUR AND FEED MILLS
GRAIN ELEVATORS, WAREHOUSES**

The Spencer Organization enjoys a long, enviable record for successful accomplishment, having erected some of the largest and most complete structures in this country.

Enquiries for Information and Estimates Cordially Invited

SPENCER CONSTRUCTION CO.

Garrett Building

Baltimore, Maryland

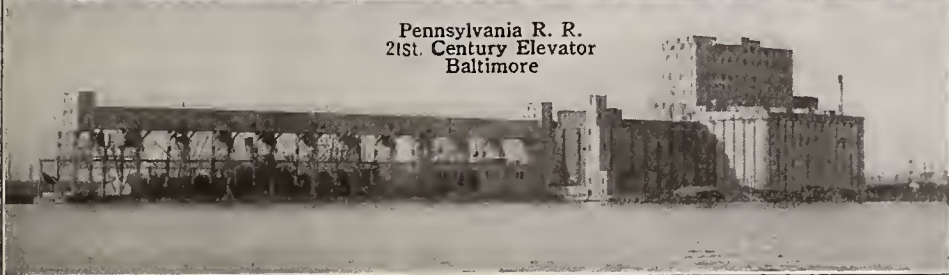
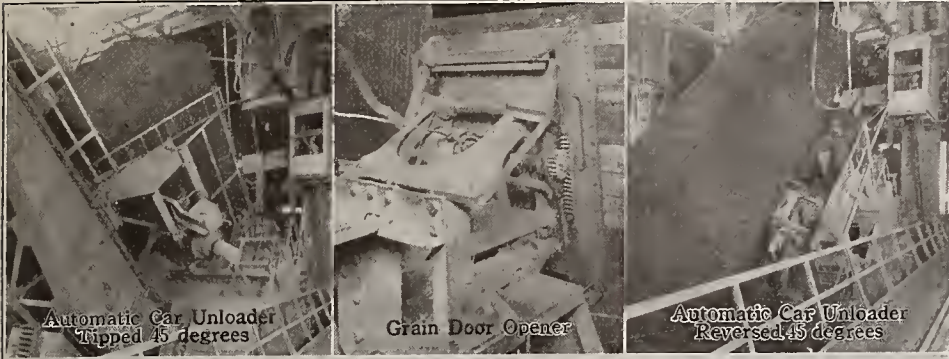

JAMES STEWART & COMPANY, Inc.

1210 Fisher Bldg. Chicago, Ill. **Designers and Builders Grain Elevators** W. R. SINKS Manager
In all parts of the world

Every day in every way we are designing and building better and better Grain Elevators. We have built for many of your friends—Eventually we will build for you. Why not now?



L. A. STINSON CO.

Engineers and General Contractors

ELEVATORS, MILLS AND WAREHOUSES COMPLETE

National Life Building Chicago, Ill.

General Overhauling and Improvements

THE POLK SYSTEM

All-steel machines for all kinds of **CIRCULAR CONCRETE CONSTRUCTION**

We contract grain storages, water towers and coal pockets.

Polk-Genung-Polk Company

Fort Branch,

Indiana

Reliance Construction Company

Furnish Plans, Estimates and Build COUNTRY GRAIN ELEVATORS

Our long experience as a builder of elevators insures you an up-to-date house. Write today.

Board of Trade Building,

INDIANAPOLIS, IND.

Burrell Engineering & Construction Co.

Designers of Grain Elevators, Flour Mills and Associated Buildings

513 West Jackson Boulevard

Chicago, Ill.

P. F. McALLISTER & CO.

CONTRACTORS - DESIGNERS Grain Elevators Ear-Corn Plants

COMPLETE

Locust Street Viaduct

Bloomington, Ill.

TOWNSEND B. SMITH

Designer and Builder

of

Grain Elevators

DECATUR, ILL.

FEGLES CONSTRUCTION CO., LIMITED
ENGINEERS—CONTRACTORS GENERAL OFFICES: MINNEAPOLIS AND FORT WILLIAM



SPECIALIZING in the construction of fire-proof grain elevators of advanced design. We are prepared to build anywhere. The following are now building:

- STATE OF NEW YORK—BROOKLYN, 2,000,000 BU. ELEVATOR AND SHIPPING GALLERIES. (ILLUSTRATION.)
- STATE OF NORTH DAKOTA—GRAND FORKS, 2,000,000 BU. ELEVATOR AND 3,000 BBL. MILL.
- ARCHER DANIELS LINSEED CO., BUFFALO, ¼ MILLION BU. ELEVATOR AND A REAL MARINE TOWER.
- PILLSBURY FLOUR MILLS CO., ATCHISON, KAN., ¼ MILLION BU.—FINEST MILLING ELEVATOR IN AMERICA.
- N. M. PATERSON & CO., LTD., FORT WILLIAM, ONT., ¼ MILLION BU. STORAGE.



Manchester Ship Canal Elevator
Manchester, England
Capacity 1,500,000 Bushels
Completed 1914



Buenos Aires Elevator Co.
Buenos Aires, Argentina
Capacity 750,000 Bushels
Completed 1920



John S. Metcalf Co. Grain Elevator Engineers



Chicago & North Western Railway Elevator
South Chicago, Illinois
Capacity 10,000,000 Bushels
Completed 1920

OFFICES:

Chicago, Illinois, - - - 108 S. La Salle Street
Montreal, Canada, - 54 St. Francois Xavier Street
Melbourne, Australia, - - 395 Collins Street
Buenos Aires, Argentina, S. A., 639 Calle Maipu

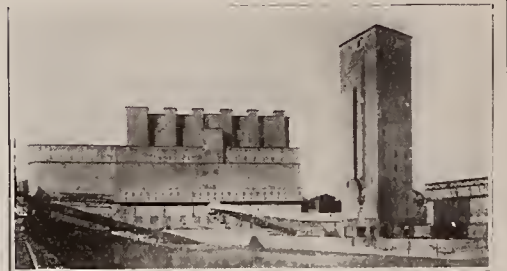

Harbour Commissioners Elevator No. 2
Montreal, Quebec
Capacity 2,600,000 Bushels
Completed 1912



Sydney Terminal Elevator
Sydney, Australia
Capacity 6,400,000 Bushels
Completed 1921



MONARCH

Built Elevators
Assure You
Economical Design
First Class Work
Efficient Operation
and
Satisfaction
Let Us Submit
Designs and Prices

One of the Modern Houses Which Has Made a Record
for Rapid and Economical Handling
CONCRETE CENTRAL, BUFFALO, 4,500,000 Bu.



MONARCH ENGINEERING CO. - - - BUFFALO, N. Y.



The Barnett & Record Company GENERAL CONTRACTORS

Designers and Builders of

Grain Elevators, Flour Mills and Heavy Structures

Reinforced Concrete and Steel Ore Dock constructed at Superior, Wisconsin, for the Allouez Bay Dock Company. Entirely Fireproof.

Write for Designs and Estimates

OFFICES:

Minneapolis, Minn.

Duluth, Minn.

Fort William, Ontario

BALTIMORE, MD.
HORN & HORN BLDG.
Telephone Plaza 3722

THE M. A. LONG CO.
ENGINEERS AND CONSTRUCTORS
GRAIN ELEVATOR DEPARTMENT

NEW YORK, N. Y.
30 CHURCH ST.
Telephone Cortlandt 181

GRAIN ELEVATORS
FLOUR MILLS
STORAGE BINS and TANKS



STORAGE FOR SECURITY CEMENT & LIME CO.,
SECURITY, MD.

CONSULTING
DESIGNING
CONSTRUCTING

ANY TYPE OF CONSTRUCTION

BUILDINGS AND COMPLETE MACHINERY
INSTALLATIONS AND EQUIPMENTS

ARE YOU WORRIED

about the condition of that grain in your bins?
Let us equip your storage with a

Zeleny Thermometer System

to tell you the exact condition of
the grain and cut out the worry

Over 100 Elevators Equipped

Write for Description

WESTERN FIRE APPLIANCE WORKS
542 South Dearborn Street Chicago

PLAY SAFE Take No Chances
with Explosive Dust

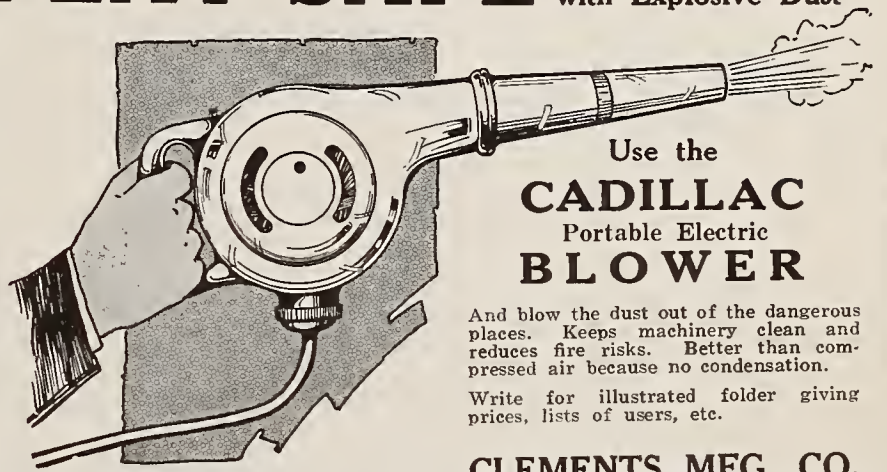

Use the
CADILLAC
Portable Electric
BLOWER

And blow the dust out of the dangerous
places. Keeps machinery clean and
reduces fire risks. Better than com-
pressed air because no condensation.
Write for illustrated folder giving
prices, lists of users, etc.

Weighs only 6 lbs. and attaches to any
light socket.

CLEMENTS MFG. CO.
610 Fulton St. Chicago

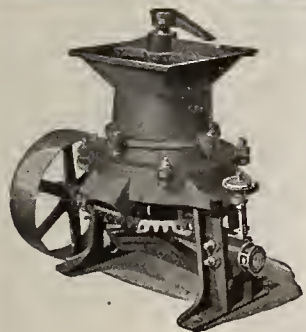

**YOU CAN'T
GO WRONG**

when you install
TRIUMPH
Corn and Cob
CRUSHERS

Let us send you a descriptive
bulletin. It tells all about them.

THE C. O. BARTLETT & SNOW CO.
Cleveland, Ohio

Transit Leaks

are unknown to the grain ship-
pers who use

**KENNEDY
Car Liners**

Enormous Increased Sales prove
the Efficiency, Merit and Service-
ability of these liners.

The Kennedy Car Liner

is the only device offered the
grain shipper that makes a car
Leak-Proof. Cheap—Modern—
Profitable. Write now for par-
ticulars.

THE KENNEDY CAR LINER & BAG CO.
Shelbyville, Indiana, U. S. A.

**STUDABAKER GRAIN AND
SEED COMPANY**

BLUFFTON, INDIANA

Operating Country Elevators

CORN and OATS Shippers
Buy and Sell CLOVER and TIMOTHY Seed under
purity and germination tests.

MAIL US SAMPLES

Our Specialties—Fancy Alfalfa and Soy Beans

We can now supply
Elwood's Grain Tables
\$2.00 per copy

JONES-HETTELSATER CONSTRUCTION CO.

Designers and Builders

MILL BUILDINGS—ELEVATORS—FEED PLANTS

706 Mutual Bldg., Kansas City, Mo.

Siding and Roofing

Corrugated or Flat
Galvanized or Painted
Immediate Shipment from Stock

Nails



Write—Wire—Phone

Steel Mfg. Warehouse
1449 GENESEE KANSAS CITY, MO.
COMPANY

GIBBS' PATENT DUST PROTECTOR



is invaluable to opera-
tives in every industry
where dust is trouble-
some, affording per-
fect protection with
perfect ventilation.
Thoroughly tested for
many years in every
kind of dust. Nickel-
plated protector \$1.25.
Canada \$1.50, post
paid. Circulars free.

GIBBS RESPIRATOR CO.
246 Forest Ave. River Forest, Ill.

DIRECT HEAT OR STEAM CONTINUOUS FLOW MADE IN ALL SIZES
Randolph Grain Driers
O. W. RANDOLPH CO. TOLEDO OHIO, U. S. A.

The Corn Exchange National Bank

OF CHICAGO

Capital - - - - - \$ 5,000,000.00
Surplus - - - - - 10,000,000.00

OFFICERS

ERNEST A. HAMILL, President	EDWARD F. SCHOENECK, Cashier
CHARLES L. HUTCHINSON, Vice-Pres.	LEWIS E. GARY, Assistant Cashier
OWEN T. REEVES, JR., Vice-President.	JAMES A. WALKER, Assistant Cashier
J. EDWARD MAASS, Vice-President.	C. RAY PHILLIPS, Assistant Cashier
NORMAN J. FORD, Vice-President.	FRANK F. SPIEGLER, Asst. Cashier
JAMES G. WAKEFIELD, Vice-Pres.	WILLIAM E. WALKER, Asst. Cashier.

DIRECTORS

WATSON F. BLAIR	CHARLES H. HULBURD
CHAUNCEY B. BORLAND	CHARLES L. HUTCHINSON
EDWARD B. BUTLER	JOHN J. MITCHELL
BENJAMIN CARPENTER	MARTIN A. RYERSON
HENRY P. CROWELL	J. HARRY SELZ
ERNEST A. HAMILL	ROBERT J. THORNE
	CHARLES H. WACKER

UNITED STATES DEPOSITARY

Foreign Exchange Cable Transfers Letters of Credit

Accounts of grain elevator operators and commission men throughout the country respectfully solicited

The Baltimore and Ohio Railroad Co.'s New Elevator in Baltimore Will Be Equipped With

8 No. 12 Invincible Receiving Separators
And
2 No. 10 Invincible Oat Clippers

The two other railroad export elevators in Baltimore that are equipped with Invincible Cleaners are the Western Maryland and the Pennsylvania.

Abundant testimony of the service and satisfaction rendered by Invincible machinery.

Invincible Grain Cleaner Company
SILVER CREEK NEW YORK

REPRESENTATIVES

F. H. Morley, Jr., 825 Webster Bldg., Chicago, Ill.
C. Wilkinson, 6027 Chestnut St., Philadelphia, Pa.
C. L. Hogle, 30 S. Arlington St., Indianapolis, Ind.
F. J. Murphy, Postal Telegraph Bldg., Kansas City, Mo.
H. C. Purvine, 111 E. 5th St., Bristol, Tenn.
Bert Eesley, P. O. Box 363, Freemont, Ohio.
Strong-Scott Mfg. Co., Minneapolis, Minn.
King-Sprague Co., 112 Market St., San Francisco, Cal.
Grain Cleaners, Ltd., 75 Mark Lane, London, England.

HESS GRAIN DRIERS and CONDITIONERS

Moisture Testers
and Accessories
Dockage Sieves and
Scales
Emerson Kickers
Boerner Samplers
Bucket Testers and
All Kinds of Sampling
and Testing
Apparatus

Ask for booklets

Hess Warming and Ventilating Co.
1210 Tacoma Bldg. Chicago

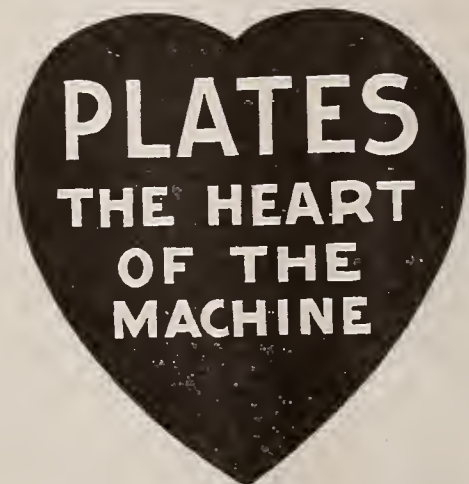

The user of Bauer Ball-Bearing Attrition Mills gets the benefit of all the famous Bauer features and, in addition, something no other Mill can duplicate for economy and uniformity of product—BAUER PLATES.

- BECAUSE**—They cost less for Power per ton of Material ground.
—They are the most uniformly perfect plates made.
—Every element of risk is eliminated.
—Fewer plate changes are required.
—One of the foremost metallurgists in the U. S. A. is on the job in the Bauer Laboratory every day testing the Metals in every run of Bauer Plates.
—Bauer Plates are the highest grade Plates manufactured.

For more detailed information about BAUER BALL-BEARING ATTRITION MILLS, write today.

The Bauer
COSTS LESS PER HOUR

The Bauer Bros. Co.
517 Bauer Bldg.
Springfield, Ohio.

?

CHIMNEY

*If there is a question
of its safety—Rebuild*

Mutual Fire Prevention Bureau

230 E. Ohio St.

Chicago, Ill.

Representing the

Mill Mutual Fire Insurance Co.'s

ELIMINATE WEEVIL

with

Liquefied Hydrocyanic Acid

Developed for the elimination of Moth and Weevil in mills, elevators and grain in storage

Endorsed by

**The Mutual Fire
Prevention Bureau**

A. R. Young Material Co.

1710 Grand Ave.

Kansas City, Mo.



The Day Dust Collecting System

Dust Collectors alone do not prevent explosions in elevators, but Day Dust Collecting Systems do when properly installed.

For catalog write

THE DAY COMPANY, Minneapolis, Minn.

SHARP CRACKED CORN and CLEAN CRUSHED OATS

are most economically
made on

GIBSON MILLS

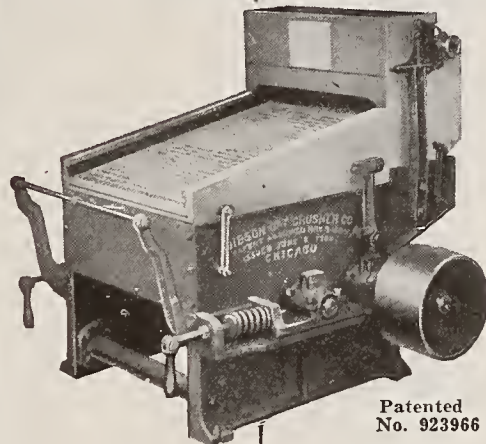

Patented
No. 923966

Gibson Oat Crushers are built in eight sizes—500 to 5,000 lbs. per hour. Gibson Corn Crackers in four sizes—5,000 to 12,000 lbs. per hour. **Shipped on trial.**

8,000 lbs. of Cracked Corn—less than 2% meal—using only 5 H. P.—the No. 18 GIBSON CORN CRACKER will do it.

Gibson Oat Crusher Co.

Patentees & Mfrs.

1328 McCormick Bldg.

CHICAGO

This Mill turns out Quality Feed and keeps on doing it year after year

A large capacity is maintained for years with the MONARCH Ball Bearing Attrition Mill without "shutdowns" for tramming or frequent delays that lose time and profits.

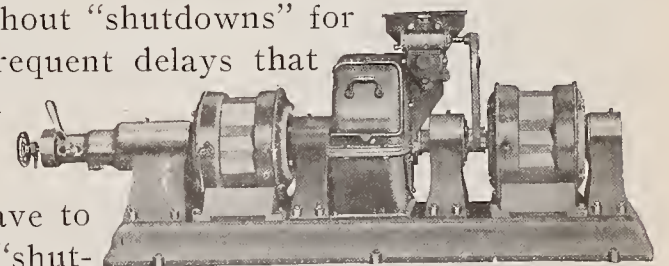

You don't have to worry about "shutdowns" for tramming the MONARCH—tramming devices are useless, as the runner heads never get out of tram.

The MONARCH grinds feed just as fine and uniform as customers want it.

Special features, developed after long experience in the building of milling machinery, are used on the MONARCH Attrition Mill to turn out a quality feed with fewer shutdowns, and less cost for power.

Let us send you a 16-page booklet—just printed—which describes the MONARCH in detail—write for a copy.

SPROUT, WALDRON & Co., 1203 Sherman St., Muncy, Pa.

GEORGE J. NOTH, MGR.
CHICAGO OFFICE
9 S. CLINTON ST.

H. C. MALSNESS, MGR.
KANSAS CITY OFFICE
308 NEW ENGLAND BLDG.



THE MONARCH MILL BUILDERS

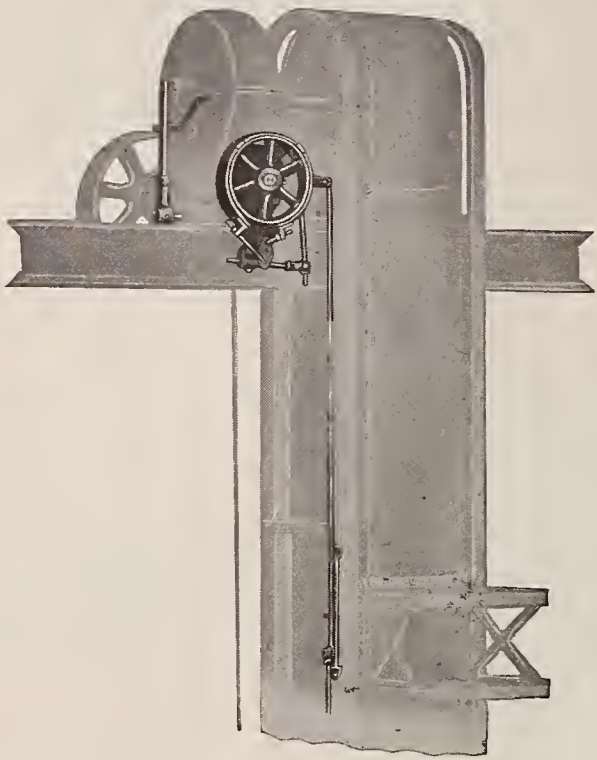

**N. & M. CO. SERVICE ELEVATOR
WITH
AUTOMATIC
SAFETY DEVICE**

WITH the upper terminal automatic stop in operation there is no danger of being carried overhead and injured. The weight of the passenger after the top floor is reached automatically throws a lever, shutting off the power and applying the brake, thereby locking the belt and steps against movement in either direction.

The automatic stop mechanism furnished with the Nordyke & Marmon Company service elevator adds the vital feature of safety to the elevator's other excellent qualities of reliability and utility.

Send for Service Elevator Circular.

NORDYKE & MARMON COMPANY

Established 1851

INDIANAPOLIS

INDIANA

AMERICA'S LEADING MILL BUILDERS

**International
Acceptance Bank**
INCORPORATED

31 Pine Street, New York

Capital, Surplus and Undivided Profits \$16,400,000

A Complete International Banking Service

Our Booklet "Acceptance Financing" Will Be Sent on Request

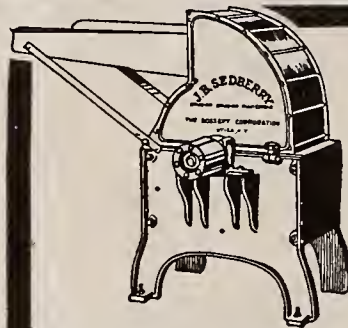

**Put an End to
Your Grinding Troubles**

Just think of it! A mill with no grinding plates, burrs, knives or gears, to break or wear out. A mill that cannot be harmed by nuts, bolts or other foreign material. The grinding is done by grain against metal --- not metal against metal as in other grinding processes.

By cutting out repair expense you increase your profits. Once a "JAY BEE" owner, always a booster.

NOW IS THE TIME to buy your

JAY BEE

feed mill. You will want to grind from three to seven thousand pounds per hour of ear corn in one operation. You will want to grind your oats and barley, hulls and all, into middlings. Do not buy oat middlings. Make them yourselves and save the consumer the freight, and make a greater profit yourself. For full particulars address THE BOSSERT CORPORATION, Utica, N. Y., or Jay Bee Sales Co., Box 231, Rushville, Ind.



Make Feed Grinding More Profitable!

Bowsher's "Combination" Mills do this

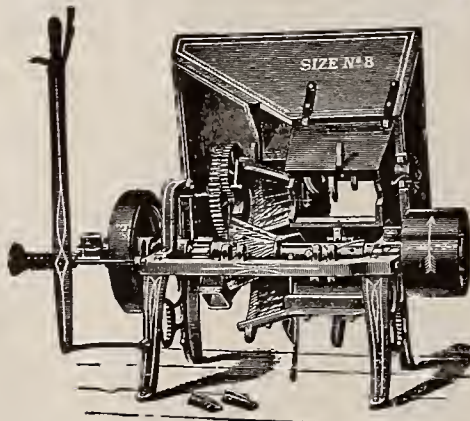

Because their large capacity, cone-shaped grinders and positive self ear feeders are properly designed to direct every ounce of power energy to the actual reduction of the grain.

Crush and Grind ear corn, husked or unhusked, alone or mixed with any kind of small grain in any desired proportion. Reduce the material to any fineness desired for feeding purposes.

11 Sizes, 2 to 25 H.P.

Sold with or without Sacking Elevator.

The N. P. Bowsher Co., South Bend, Ind.

**The "Knickerbocker Cyclone"
Dust Collector**



For Grain Cleaners

ALL STEEL



Write for Catalog

The Knickerbocker Company

Jackson, Mich.

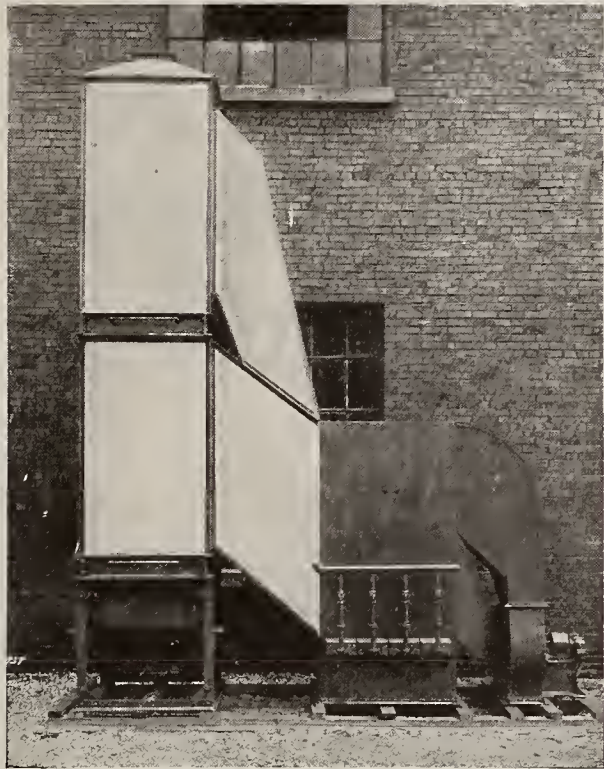

No. 1-5-5 Portable Drier

For THE SMALL MILL

The accompanying illustration shows our smallest portable drier and cooler. It has an hourly capacity on wheat or corn of 30 bushels per hour. It stands 14 feet high, is 10 feet 8 inches long, and 2 feet 9 inches wide. The entire apparatus is built of the same material and gauges as our larger driers and is a practical machine in every respect. Send for catalog 26.

If you are in need of a rotary drier for meal, grits, etc., it will be worth your while to write for information on the Ellis Ball Bearing Rotary. It is in a class by itself.

THE ELLIS DRIER COMPANY, Chicago, U. S. A.

WE CAN NOW SUPPLY

Elwood's Grain Tables

Show the value of any number of bushels or pounds of **WHEAT, RYE, OATS, CORN OR BARLEY** at any given price from 10 cents to \$2.00 per bushel. One of the most useful books ever offered to millers. Indorsed by prominent millers and grain dealers. Bound in cloth, 200 pages. Mailed on receipt of price.

\$2.00

Mitchell Brothers Publishing Co.
431 S. Dearborn St. Chicago, Ill.

Speed Production!

Have a careful estimate made of the TOTAL time and energy taken each day by your employees running up and down stairs. You'll be surprised at the amount, in dollars and cents, such a total represents. Save that waste and speed up production by installing the

Humphrey Elevator

A Safety Belt Employees Carrier

Used by HUNDREDS OF LEADING MILLS AND ELEVATORS. 36 years of building and improving have made it unexcelled for economical operation, safety and dependability. Note these features:

Compact driving mechanism running in oil bath; electric silent chain drive; Humphrey Patented Automatic Safety Stop; quick, easy control.

Send for reliable data on actual savings that Humphreys are making in plants of various capacities.

Humphrey Elevator Company
1131 Division St., Faribault, Minn.

There is ONLY ONE GENUINE Humphrey Elevator



Our motto is—"Service"—Try us out

WESTERN

Shellers and Cleaners
and
Complete Elevator Equipments



DECATUR

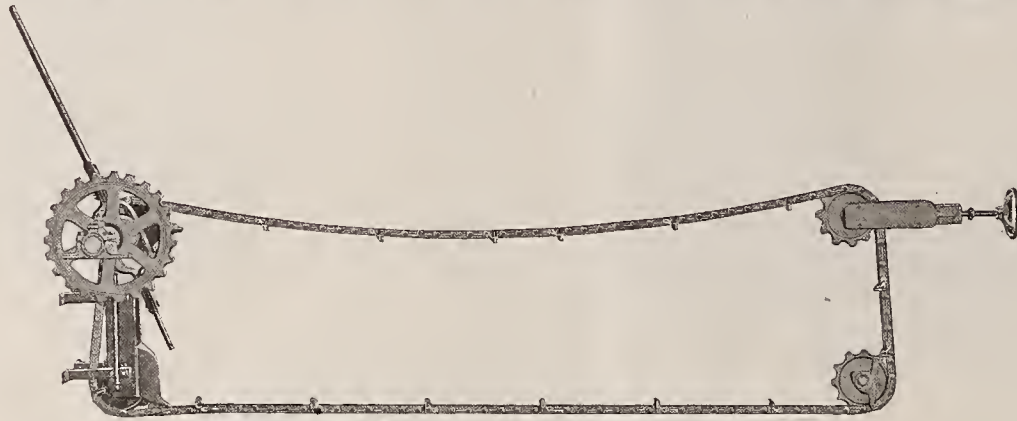

"Western" Chain Conveyor Feeder—Style B

UNION IRON WORKS

Write for Catalog No. 27

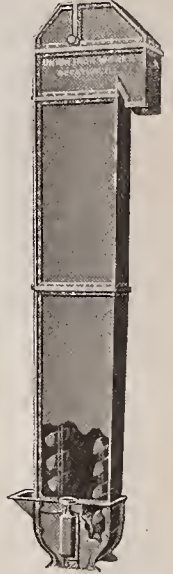

ILLINOIS

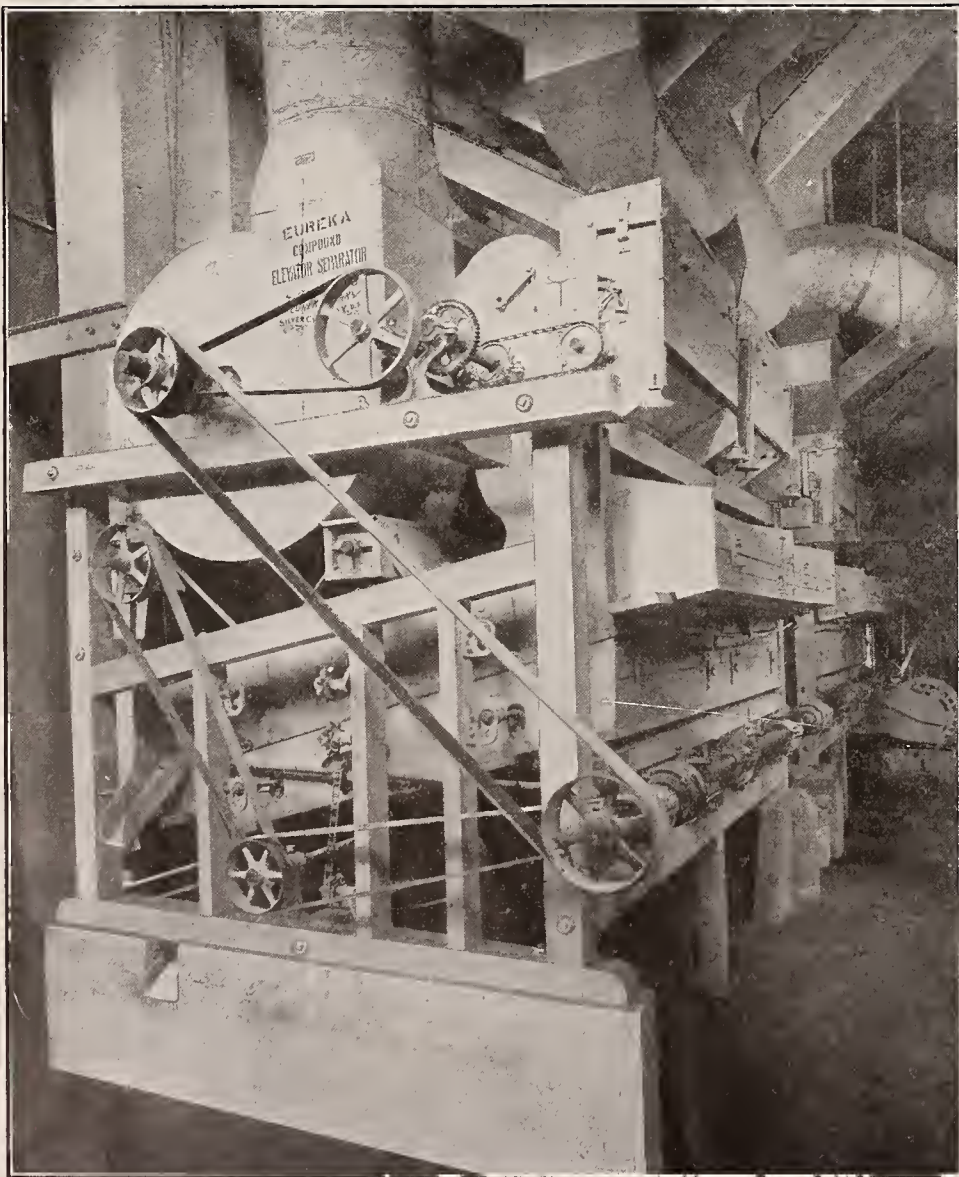

The
MOST TALKED ABOUT
Grain Handling Plant
in America
is the
**NORFOLK
MUNICIPAL ELEVATOR**

Said to be the world's fastest working house. In its construction are embodied all the latest ideal features, including of course

EUREKA Ball-Bearing Eccentric **CLEANERS**

These machines are raising export wheat two grades. If you too want a good separator

Write



S. HOWES CO., Inc.
Silver Creek, N. Y.



CALDWELL

HALF a million dollars worth of well selected stock, constantly maintained, and an organization keyed up to the theory that plant efficiency is measured by the number of orders shipped on the day of receipt, accounts for Caldwell service.

If you need gears, sprockets, transmission machinery, Helicoid Conveyor or any of the Caldwell specialties promptly, wire Caldwell, or call up the nearest Link-Belt office. You will find Link-Belt Company offices in all principal cities.

H. W. CALDWELL & SON CO.
LINK-BELT COMPANY, OWNER

CHICAGO, 17th Street and Western Avenue

Dallas, Texas, 709 Main Street

New York, Woolworth Building

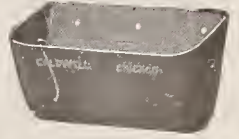
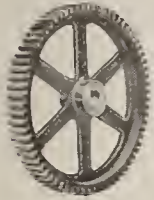
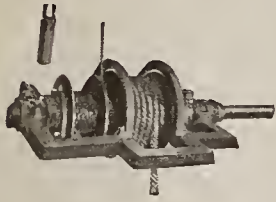

WALLS, BINS AND GRAIN ELEVATORS

By MILO S. KETCHUM

Design and construction are covered completely in this book of 556 pages. The new second edition brings it up to the minute with fresh data, new cuts, and a modern treatment throughout. Over 150 pages were added to the old edition. The new chapters on "Reinforced Concrete" and "Methods of Construction and Cost of Retaining Walls" are especially valuable. It is the standard work on stresses due to granular materials.

PRICE \$5.00 POSTPAID

MITCHELL BROS. PUBLISHING COMPANY

431 S. DEARBORN STREET
CHICAGO, ILL.

Constant Fan Discharge Corn Sheller

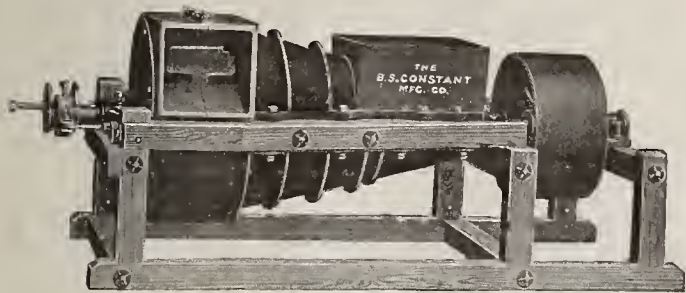

Constant Fan Discharge Corn Sheller

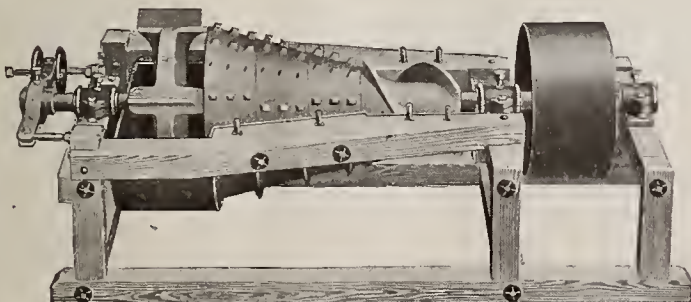

Upper Shell Removed Showing Fan and Cylinder

We are the Originators of the Fan Discharge Corn Sheller
**Fan Discharge Corn Sheller Mounted on Wood Frame
for Shelling Ear Corn**

Three-piece sectional cylinder eliminates necessity of replacing entire cylinder in case of accident.

Heavy reinforced rib shells mounted individually above and below frame, allowing replacement without disturbing cylinder.

Positive Lock wheel adjustment allows for adjustments whether idle or in operation.

Discharge housing made in sections permitting any type of discharge without change of pattern.

Screw type feed collars made up in sections.

Teeth in shells and cylinder have chilled, hardened surfaces, insuring long wear.

All shellers of capacity over 400 bu. per hour are equipped with out-board bearing as shown.

Pulley and adjustment can be located on either end to suit conditions.

All Constant Shellers are guaranteed to shell their rated capacities.

30 DAYS' FREE TRIAL

Try this sheller for 30 days. Give it the acid test of actual service and if you are not satisfied, ship it back to us. Send today for free trial offer.

The B. S. Constant Mfg. Co., Bloomington, Ill.

Elevating, Conveying and Power Transmitting Machinery. Complete Equipments for Grain Elevators.

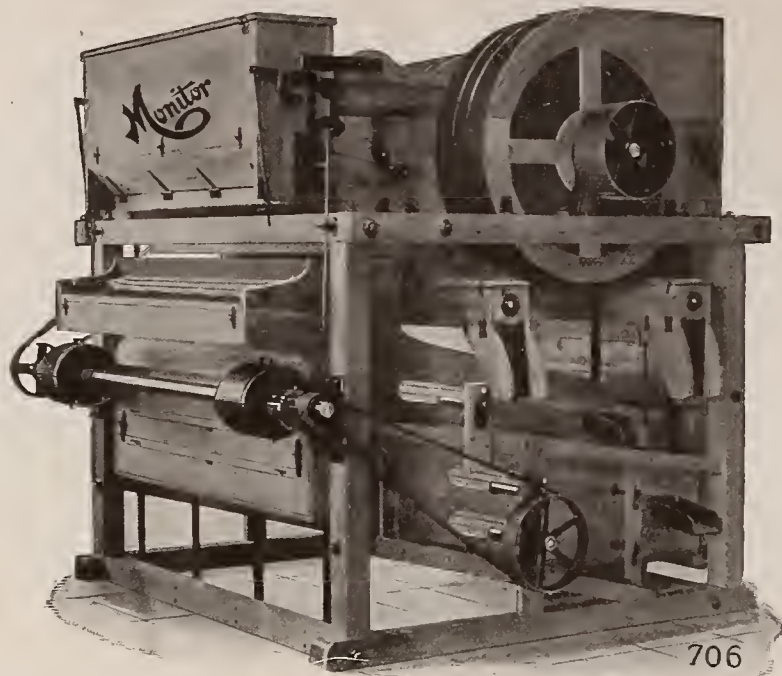

WASTE IN CLEANING

The invisible loss—that which is natural in the proper cleaning of grain, is about all the loss there should be. Yet, many Cleaners show abnormal shrinkage but if you would examine the screenings, you would find the reason. In such cases, you would find them full of good grain.

The MONITOR Separator is noted for its close cleaning with minimum shrinkage. This is because it does not pull out good kernels with the screenings—they pass on with the cleaned grain. It does stop and remove all foul material as well as badly shrunken or weevil eaten kernels. But that is what you want.

If you use the MONITOR, you know a good cleaner. If you do not use it, you are losing a nice margin of profit.

HUNTLEY MFG. CO.

Department E

SILVER CREEK, N. Y.

OUR REPRESENTATIVES, AT YOUR SERVICE

CHICAGO
A. D. McPherson, 410 Webster Bldg.
MINNEAPOLIS
A. F. Shuler, 218 Iron Exchange
KANSAS CITY
J. B. Ruthrauff, Coates House

CANADIAN PLANT
Tillsonburg, Ontario
WINNIPEG, MAN.
Will Hill, 217 Grain Exchange
J. J. Ross Mill Furnishing Co.
Portland, Ore. - Seattle, Wash.

DAYTON, OHIO
W. B. Sutton, 236 Boyer St.
HARRISBURG, PA.
B. L. Brooks, Governor Hotel
HIGH POINT, N. C.
C. T. Burton, 116 Taylor St.

A monthly journal devoted to the elevator and grain interests.

Official paper of the Grain Dealers' National Association and of the Illinois Grain Dealers' Association.

Established in 1882.



Published on the fifteenth of each month by Mitchell Bros. Publishing Co., 431 So. Dearborn St., Chicago, Ill.

Subscription price, \$1.00 per year. English and Foreign subscription, \$1.75 per year.

Established in 1882.

VOL. XLII

CHICAGO, ILLINOIS, NOVEMBER 15, 1923

NO. 5

New York's Place in Our Export Grain Trade

Some Facts and Figures Bearing on the Export Situation of the Past and the Future Which We Are Apt to Forget

WHILE our exports of grain and grain products have fallen off considerably from the enormous shipments of last year, the record for the first nine months of 1923 shows that we will export considerably more of all grains this year than we did in the five years preceding the war. This is contrary to the general belief, for there has been so much talk of stagnant foreign trade, that we assume that our foreign market has become negligible.

It is well, occasionally, to take a survey of the situation lest we lose the proper perspective. From January 1 to September 30 of this year grain exports can be compared with last year as follows, the 1922 figures being in parenthesis in each case:

Wheat, 80,196,646 bushels (126,155,959); flour, 10,651,444 barrels (10,458,370); rye, 29,118,670 bushels (35,868,546); rye flour 28,518 barrels (38,238); corn, 38,660,491 bushels (141,180,889); cornmeal and flour, 514,384 barrels (493,116); other corn products 51,024,441 pounds (236,039,880); oats, 2,825,979 bushels (24,023,569); rolled oats and meal, 101,888,235 pounds (75,649,933); barley, 9,763,671 bushels (13,185,553); malt, 2,781,546 bushels (3,628,132).

The discrepancy between this year and last is marked, and the prevailing discontent is largely due to the fact that, while the international trade in grain is gradually working back to the pre-war basis,

our production is still on the scale made necessary by war demands. There is nothing more certain than that our grain exports will not again assume the proportions of war time trade, except in event of another war, and that we must restrict our bread grain production to a pre-war basis, allowing for the increase in population of our own country. This latter factor, as restricted by our immigration laws, will be much slower than it was in the 50 years preceding 1910.

During the years of stimulated export activity, our facilities failed to keep up with the pressure put upon them. This year, however, they have been found adequate, with little congestion or delay anywhere from country station to ocean vessel. From this premise it might be assumed that the plans for increased export facilities, such as the St. Law-

rence waterway, the extension of inland waterway service, and new elevators at seaboard, are unnecessary. But that is far from the case. These improvements are not merely to afford greater facilities, but will insure a more economical movement, and this is more essential now than during the war, and even more necessary than the increased physical capacity which they will afford. Not only does the impoverished condition of importing countries make the price factor of greater importance, but the redistribution of population from manufacturing centers to small land holdings in many countries of Europe, increases the competition among exporters for what trade remains. The importance of the distribution of population on the

agricultural production stood at 118 and manufactures at 163. The population of the country during this same period had grown more than 20 per cent. Nearly all of this addition to our people was found in cities and towns. Of the 15,000,000 people who had been added to our numbers, more than 12,000,000 became city dwellers. For the 20 years, 1899-1919, the volume of farm products had increased by 35 per cent, while manufactured output had grown by more than 100 per cent. Our population during the same time had become 40 per cent larger, while the dwellers in cities and towns had increased by 60 per cent . . .

"In addition to these domestic factors which were raising the price of farm products between

1899 and 1909, the foreign situation was likewise favorable to an increase in agricultural prices. Except for our slight unpleasantness with Spain in 1898, the world had been at peace for almost 30 years. But in 1900 came the Boer War, and in 1904 the Russo-Japanese war. Both these conflicts had the effect of stimulating the demand for American farm products. The nations involved in these wars were able to command credit with which to buy the things they needed. The three decades of peace and of industrial development which had preceded had placed the world in a position where Government bonds were readily absorbed by the international money mar-



FLOATING GRAIN ELEVATORS IN NEW YORK HARBOR

demand for farm products and the corresponding price movement, was recently pointed out by David Friday who was president of the Michigan Agricultural College, but proved to be too good an economist and too honest in his utterances to satisfy the powers-that-be in that institution. Speaking of the greater relative increase in value of farm products than of manufactured products from 1899 to 1917, Mr. Friday said:

"The position of first importance among the causes which were at work must be assigned to the more rapid growth of population and production in the field of manufacture as compared with agriculture. The average agricultural output during the first decade of this century was only 11 per cent more than in 1899; while in manufactures it amounted to 34 per cent. In 1909, the index of

ket. In addition to these military conflicts, Europe, like ourselves was enjoying an unprecedented industrial development. Mining, manufacturing and construction work were active and were yielding large profits. Population was increasing. The growth of cities is not alone an American manifestation during the first two decades of this century; it was universal in the Western world. All of this accentuated the tendency of demand for agricultural products to outrun the supply at the old prices."

During all this period discussed by Mr. Friday, prices were governed by natural economic causes, and not by manipulation, and unfair practices as was so often charged through the years. But now to get back to the immediate present:

In our export grain trade New York has always

been and will continue to be a dominant factor. Through that port in 1922, the following grains in bushels were handled: Barley, 2,178,154; corn, 25,340,573; oats, 19,819,717; rye, 10,160,407; wheat, 18,769,377. Even with the new Gowanus Bay Elevator, the storage facilities at the port are wholly inadequate to handle the volume of grain. Only a limited number of full cargoes are sent out so that a system of lighterage has been developed by which grain parcels can be loaded while a vessel is berthed to take on other cargo. This lighterage system is expensive, compared with loading direct from an elevator, but the conditions at the port make it the only possible way of handling the grain commerce.

So far as the exporter is concerned the favorable rates often obtained for grain parcels to complete a cargo, more than make up for the extra cost of handling. The fleet of floating elevators shown in the illustration, which are operated by the International Elevator Company, are a necessary part of the facilities at the port, and their usefulness will be increased rather than diminished as the motor boat service from the head of the lakes to the port is further developed.

THE GOULD PLAN

There has been a great deal of talk about the "Gould Plan" and there will be a great deal more before this wheat business is settled, so it is well to have in mind just what it means.

The Gould plan was proposed by W. E. Gould of Kankakee, Ill., a banker and farmer. As a first step, Mr. Gould proposes an increase in the duty on wheat to provide an absolute bar to grain imports from Canada. Next, that the War Finance Corporation finance the shipment of 50,000,000 bushels of wheat to Germany by the purchase of drafts on wheat shipments sent to that country without recourse on the wheat shipper. In order to equalize the benefits of the plan, the wheat to be exported would be as follows:

Durum wheat, 10,000,000 bushels; Pacific Coast wheat, 10,000,000 bushels; east of the Rockies, 30,000,000 bushels. One-third of all the wheat would be in the form of flour, all of the wheat to be American-grown and all of the flour American milled. Shipments would be made partly in United States Shipping Board and part in German bottoms.

Selling this wheat to Germany would put this country on a domestic basis and would not affect the world market, because otherwise the German population will subsist on coarse grains and potatoes, having no money to buy wheat. Also it was contended that such a move would save Germany from bolshevism, arresting the present menace to civilization.

When Germany comes back economically, the United States shall have the first call on that country's trade by reason of the good feeling thus created. If the War Finance Corporation has not the power now to finance the shipments, the President was urged to call an extra session of Congress to provide the authority.

The plan was submitted to President Coolidge and Secretary Wallace by a delegation of grain dealers from Chicago and Omaha and bankers and farmers. The grain dealers had no authority to represent the exchanges.

FIGHTING THE CHINCH BUG

H. M. Bainer, director of the Southwestern Wheat Improvement Association, on October 29 called a meeting of the entomologists of Kansas, Nebraska, Missouri and Oklahoma, at Kansas City for the purpose of formulating a systematic plan of control of chinch bugs in the states mentioned. In all, seven entomologists were present; three from Kansas, two from Oklahoma and one each from Missouri and Nebraska.

The general plan of control adopted was that of burning the hibernating places of these insects between November 1 and December 15. Several reports were made showing that where farmers had been organized by school districts, townships

and counties and had burned the bunch grass, roadsides, ravines, waste places and so forth by December 15, the bugs had given no trouble the following year. It was estimated that the chinch bug damages this past year to wheat, oats and corn in the four states mentioned amounted to more than \$50,000,000.

NEW INQUIRY ON GRAIN RATES

The refusal of the railroads to lower export rates on November 1, was followed by an announcement of the Interstate Commerce Commission that a new investigation of grain rates would begin on November 14 at Kansas City.

The Commission also announced Commissioners Aitcheson, Esch and Campbell, who will conduct the investigation, will proceed to Minneapolis, where on November 26 they will not only take up the matter of rates and charges of grains, but also seek additional information for the record in the well-known case of the Public Utilities Commission of Kansas vs. the Atchison, Topeka & Santa Fe Railway.

This latter case also deals with general reductions in grain rates, but did not specifically call for any change in the rate structure on grains for export. Recently the Commission declined to hand down an opinion in this case because of its present record.

At Minneapolis the Commissioners will seek information on export rates, and also the condition of farmers in the Ninth Federal Reserve district, who are responsible for the President's action in seeking a voluntary reduction in rates.

From Minneapolis the Commissioners will proceed to Spokane, Wash., where on December 5 the railroads and wheat growing farmers in Washington, Montana, Idaho and Oregon will present their views in the grain rate situation in the Northwest. On December 11, at San Francisco, the Commissioners will hear future testimony, and will then proceed to Phoenix, Ariz., December 12, where another hearing will be held. Additional dates and places for hearings will be announced later.

TELEPHONE TACTICS

BY TRAVELER

It's becoming more apparent every day that old-time methods won't get the elevator man very far in the battle for business. Only the most up-to-date elevators, with equally up-to-date service, can hope to get a fair share of the farmers' grain. No longer does the farmer load his wagon with grain, and then start out to hunt a place to sell it. Today, the farmer knows just where his grain is going and what disposition he's going to make of it, before he loads a bushel of it onto his wagon. Very often he is even relieved of that labor, as some elevator man, equipped with trucks, may haul it for him.

The universal use of the telephone and paved highways has wrought a complete change in the system of buying grain from the farmer. Scarcely a farmer's home today is without a telephone, and this, in a great measure, deprives the dealer of the advantage of the personal contact in the making of a deal. Formerly, if the question of a competitor paying a higher price arose, the dealer had the load of grain in his driveway and was usually able to make an adjustment of some sort which would satisfy the farmer and thus prevent the grain going to his competitor. Having the load where he could easily examine it, he might find it to be "just on the line," and would spring it a grade in an effort to keep his customer from hauling elsewhere. Many other advantages could be enumerated to show the desirability of personal contact in making purchases from farmers.

Many dealers are aware of this condition, but few seem to realize how seriously it is affecting the old-time order of doing business. They do not seem to see that, more and more, the trade coming to their elevators is made up of transients, and every day their list of regular customers is growing smaller. This, however, is quite true, and any elevator man who takes the trouble to analyze

the situation will be able to prove it in his own case.

The writer happened to be sitting in a country telephone office when a woman called an elevator for the price of wheat. Right away, she called another elevator, and after that two or three more. The operator then told me that this was a regular thing and that the women do the most of the phoning. The men go out to work in the fields, and leave instructions with the women folk to call up the various elevators in the surrounding territory and get all their prices. When the farmer is ready to haul, he starts for the elevator quoting the highest price. There is no second chance for the man who happened to be a trifle low.

Sometimes, these inquirers may be induced to give their names, and then if the elevator man finds that they are out of his territory, he may purposely spring the price to get the grain away from the dealer in that locality, or force him to pay more. The final result is to make the buying doubly hard for all the dealers, and at the same time stir up a feeling of suspicion if not downright enmity amongst the farmers.

There seems to be no satisfactory remedy to offer for this condition, unless it would be possible for dealers, within a certain territory, to get together and decide upon a fixed margin of profit. This scheme, however, has been tried before, and no matter how carefully planned, has always seemed to leave some loop-hole for the tricky dealer to jump through. Something should be done, however, as country buying of grain is, at the moment, in a very chaotic state.

CANADIAN RATE WAR ON LAKES SETTLED

BY ELMER M. HILL

Grain shippers at the Canadian Head of the Lakes are responsible for the settlement of the two months' war between the Dominion Government and American vessel owners which resulted in the withdrawal of American shipping from the Canadian grain trade during the period when boats were needed to move the crops to eastern markets. The Canadian Government accepted the proposal of vessel managers that the shippers file the necessary tariffs after the charters were made. Members of the Canadian Grain Commission and shippers at Fort William and Port Arthur held a conference at which the entire situation was satisfactorily settled.

The trouble could have been settled on the same basis two months ago when Canadian shippers indicated their desire to file the tariffs when American vessel owners and managers refused to comply with the new Canadian Grain Rates Act. While the larger American vessel owners refused to handle Canadian cargoes, many small independent lines rushed into the Canadian trade and moved a large amount of grain to Eastern markets at high rates. Shippers appeared to be ready to pay almost any price in order to get their crops East before the close of navigation on the Great Lakes.

Although some grain was moved by wild carriers, the terminal elevators at Fort William and Port Arthur were choked with grain and for a time it was apparent that shippers were face to face with a very serious situation. The failure of big American boats to handle Canadian cargoes practically eliminated the trade on the Great Lakes. The movement of Canadian export grain down the lakes has been reduced at least three-fourths. During the strike period, shippers were paying up to 5¼ cents to Georgian Bay ports, 6 cents to Buffalo and 14 cents to Montreal.

Carrying charges, however, took a drop when several American lines entered the Fort William and Port Arthur Harbors prepared to handle Canadian cargoes under the terms of settlement. Only a limited amount of late loading tonnage had been chartered up to the early part of November, owing to the failure of shippers to insure prompt dispatch. Elevators at Buffalo and other Lake Erie ports were congested last year and grain freighters were held in port from three to nine days before they

were unloaded. Many ship owners operated their vessels at a loss and do not intend to repeat the performance this year.

Shippers and vessel owners have arrived at the conclusion that the grain shipments for the season will be smaller than was figured on unless the weather remains favorable. Recent storms at the Head of the Lakes and on Lake Erie point to an early winter, and if the wintry blasts continue to appear, the greater portion of the grain now in Canadian elevators will have to be shipped by rail or held until next spring.

An increase was made in the stocks at the Canadian Head of the Lakes during the first week of November. The elevators at Fort William and Port Arthur were holding 28,717,448 bushels, which is an increase of almost 2,750,000 bushels over the previous week. Stocks at Canadian elevators have mounted steadily in the last two months.

L. H. Boyd, chairman of the Canadian Commission, announced his ruling which brought the strike of American ship owners to an end:

"We are preparing to accept as compliance with section three of the Inland Water Freight Rates Act (a) the filing with the board of tariffs by vessel companies, and (b) the filing by shippers, before loading, of copies of charters or contracts for space."

LOWER EXPORT RATES DENIED

When President Coolidge suggested to the railroads that they should lower the rate on export wheat, it is not likely that he had much idea that they would do so. A similar request, made by the Omaha Board of Trade and other bodies some months ago, was refused by the roads, who at that time gave reasons why it could not be done. Since then the grain traffic has been far behind that of last year and conditions in general have not changed materially.

The reply to the President's suggestion was given to the Interstate Commerce Commission at Washington in the form of a statement signed by the executives of both eastern and western roads, in part as follows:

"The roads have every desire to help the wheat farmer and have approached the matter in that spirit, but they believe that a reduction in the export rates will not benefit the wheat grower for the reason that, conforming to long established and well recognized economic laws, any reduction in the rates on American grown wheat will be immediately followed by corresponding lowering of rates or prices on wheat grown in Canada, Argentine and other wheat exporting countries and consequently no change in the situation will result other than a lowering of the price to the foreign consumer without benefit to the American farmer and at the expense of the railroads."

CLEAN WHEAT BRINGS HIGHER PRICES

The value of cleaning wheat at threshing time is once more demonstrated in experiments conducted in Minnesota and the Dakotas by the United States Department of Agriculture. Farmers co-operating in the experiments with the most successful recleaner gained an average of 7.3 cents per bushel on each bushel threshed. Various types of cleaning machines were operated in connection with threshers.

The 7.3 cents gain per bushel includes the higher price received for the cleaned wheat, the value of the screenings removed and used for feed, and a small saving in transportation. No charge was made to cover the operation of the recleaner, but it is pointed out that if a charge of as much as 2 cents per bushel had been made, the gain would have averaged 5.3 cents per bushel net. The simple and efficient disc recleaner designed by Department technologists received the hearty endorsement of Spring wheat farmers because the new method not only gives them a premium for their wheat but also permits them to make valuable use of their dockage which had previously been a total loss.

SEVEN BROTHERS INCORPORATED

The occultists tell us that "seven" is a mystic number and particularly lucky. Perhaps there is something in it. At any rate, it looks as though the firm of Seven Brothers, Incorporated, of Clarksburg, W. Va., was destined for a future filled with substantial success in the jobbing of grain, flour,



J. M. FRAME, PRESIDENT

feed and groceries. This is not a fanciful name, for the firm is actually comprised of seven brothers, who appear on their letter head as follows: J. M. Frame, president; R. A. Frame, vice-president; C. A. Frame, secretary; W. H. Frame, treasurer; M. V. Frame, director; W. L. Frame, director; P. B. Frame, director.

In this case we believe that seven will be luckier than six would be, because every one of the seven is full of energy, ambition and experience and will contribute to the success of the venture in just that proportion.

The president of the company is also the head of J. M. Frame & Co., of Charleston, W. Va., and this company is associated with the Seven Brothers and will take care of their interests in the southern part of the state. J. M. Frame was formerly a



RAY A. FRAME, VICE-PRESIDENT

railroad engineer, but got into the brokerage business some years ago and has made a distinct success of it.

Ray A. Frame, vice-president, is the youngest of the seven, but has had a great deal of experience, having been sales manager for a feed manufacturing company, and was active in Frame Bros. & Co., which was a flour, feed and grain company with 19 salesmen on the road. The control of the former company passed into other hands and the Seven Brothers, Incorporated, is the result.

The firm already has a comfortable grain, flour and feed brokerage business in West Virginia and in parts of Virginia, Kentucky and Maryland. Three

new offices are about to be opened up at Pittsburgh, Lynchburg, Va., and Norfolk, Va. Eventually each one of the seven brothers will have his own headquarters with a separate territory and will be in a position to furnish exceptional service in as many states. All of the brothers have had years of experience and are well acquainted with the trade which will be served, and if ambition and high ideals can establish a satisfactory business and a satisfied clientele, then the new company is assured of success from the start.

IMPROVING DURUM WHEAT

An improved strain of Kubanka wheat named Nodak has been developed which combines to a high degree the desired characters of a Durum wheat, such as resistance to stem rust, ability to yield well, and suitability for making macaroni. The Kubanka variety was chosen for improvement through selection at the Dickinson, N. D. substation, by the United States Department of Agriculture, because this variety, more than any other, possessed to a considerable extent the qualities desired.

The improvement of Kubanka Durum wheat by pure-line selection is described in Department Bulletin 1192, by the United States Department of Agriculture in co-operation with the North Dakota Agricultural Experiment Station. Of 144 pure-line strains tested for a number of years, Kubanka No. 98. (Nodak) is the most promising as it combines high yielding ability with rust resistance and good quality for making macaroni. It is an amber Durum of the Kubanka type, but has heads slightly longer than the average for that variety. It also differs from the original Kubanka in being more resistant to stem rust. Because of these characters, setting off the selection from the parent bulk variety, it is named Nodak. Under this name it will be further tested, increased, and distributed for commercial growing in North Dakota. A copy of this bulletin may be secured, as long as the supply lasts, from the United States Department of Agriculture, Washington, D. C.

FIGURES THAT LOOK LIKE FACTS

There is a story going about that the reports of enormous wheat crops in Canada, is deliberate propaganda, without foundation in fact, put out by the banks, railroads, and even the Government of Canada, to induce new settlers to come to the Dominion to replace those who have been disgusted with farm conditions there and are leaving the farms, either to locate in the city or to come to this country.

There have been too many private crop investigators from this country who have seen the Canadian crop for themselves, to give any credence to this propaganda story. It is absurd to even suggest such a thing. The total wheat crop of the Canadian provinces of Manitoba, Saskatchewan and Alberta is estimated by Government officials at 425,503,169 bushels, an increase of 50,000,000 bushels over the record 1922 yield. The three provinces now produce approximately 95 per cent of all wheat grown in the Dominion.

Forty-five and 50-bushel yields were reported in a number of areas, while in others the run was 60 bushels to the acre. The wheat weighed between 63 and 67 pounds to the bushel and more than 90 per cent of it graded No. 1 Hard.

The oats yield in the prairies was placed at 386,825,295 bushels. Other grain crops were estimated as follows: Barley, 61,540,140 bushels; rye, 24,376,560 bushels, and flax, 7,193,026 pounds.

So far as individual yields are concerned, G. G. Coate of southern Alberta made a record which leads us to believe almost anything of Canada's totals. From a field of 25 acres on his farm near Nanton, Mr. Coote threshed 1,835 bushels of wheat, an average of more than 73 bushels to the acre. He has not yet finished threshing, but his whole crop is going well over 60 bushels to the acre. Several other farmers in the province have reported yields of 50 to 70 bushels per acre.

Dust Collecting Equipment for Elevators

Results of a Preliminary Study of Dust Collecting Appliances Now Installed in Terminal Grain Elevators—Some General Recommendations

By HYLTON R. BROWN and J. O. REED

CLEANLINESS has always been considered the most effective step in dust explosion prevention and the installation of effective dust collecting equipment at every point where dust is produced has been advocated for several years¹. Elevator operators differ, however, as to the points in the plant where the installation of dust collecting equipment or the application of suction is advisable. The absence of authentic data on the quantity of dust necessary to cause an explosion under the conditions prevailing in their plants and the lack of apparatus or instruments which will readily indicate the quantity of dust present have contributed to this difference of opinion.

Tests made in the Dust Explosion Prevention Laboratory of the Department of Agriculture have

transfer houses in some of the cities visited were studied, and the information obtained was used in checking results at the terminal elevators or in developing methods of suction application to the larger houses. One Canadian plant was visited.

METHOD OF TESTING DUST COLLECTING SYSTEMS

After selecting the grain elevators at which tests were to be made and arranged for the co-operation of the owners and operators, a general survey of the plant was made. All points at which suction was applied, floor sweeps or suction inlets were provided, or natural ventilation was arranged, were noted and a general inspection was made to determine the points where dust might escape without being collected or removed. Where suction was applied the size and shape of hood, if

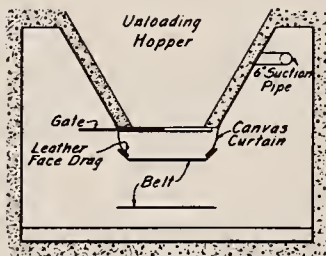
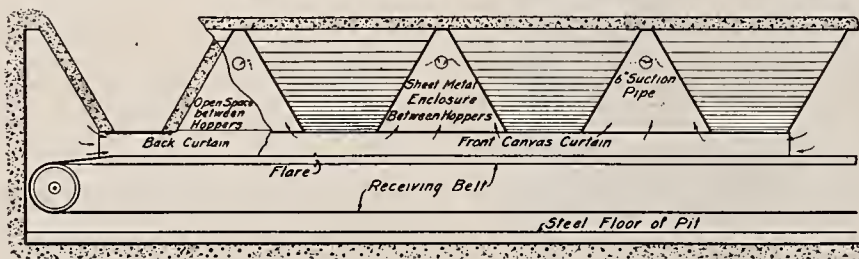

SECTION OF UNLOADING PIT

FIG. 1. SUCTION SYSTEM FOR DUST REMOVAL APPLIED TO UNLOADING PITS

shown the quantity of dry dust necessary in a given quantity of air to produce an explosion. Until a satisfactory method is developed for determining the exact conditions present and indicating whether or not the quantity of dust present under these conditions constitutes an explosion hazard, however, it seems advisable to provide dust collecting equipment at every point in a grain elevator where the quantity of dust produced is equal to or exceeds the minimum quantity necessary to start an explosion under the most favorable conditions.

To determine these points the Bureau of Chemistry of the United States Department of Agriculture made a survey of the dust collecting, dust removing and dust conveying equipment at a number of large terminal elevators. The results of this survey, together with some preliminary tests made with the dust collecting systems installed in these plants, are reported here.

PLANTS AT WHICH TESTS WERE MADE

In selecting the plants an attempt was made to secure the greatest possible variation in type of building, type of dust collecting system, and grain handling methods, in order to obtain what might be considered data generally applicable to all plants. Elevators along the Great Lakes, the Atlantic Coast and the Gulf Coast were included in the survey. As a rule, the larger plants at each place visited were selected because they offered the greatest opportunity for determining all the points in modern grain handling systems where suction should be applied.

Terminal elevators were selected for the tests because each handling of grain creates a greater quantity of dust and as a rule the terminal elevator is the last point at which the grain is handled before export shipment. Special features installed in connection with the dust collecting systems at

any, and the size of the suction pipe were noted. Tests were made to determine the suction or negative pressure and velocity of the air entering the hoods and readings were made in several of the suction trunk lines. Observations were also made at various points to determine whether or not the suction was strong enough to lift and carry grain with the dust collected.

Where the suction hoods did not seem to be operating satisfactorily an inspection was made to determine whether there were any defects in the construction of the hood or in its installation, and its distance from the fan and the number of bends or elbows in the suction line were noted. As a rule, the design or construction of suction hoods and of suction lines was still in the experimental stage. The standardization of such equipment would be a long step towards the solution of the dust collecting problem.

Pilot tubes with both mercury and water manometers and an anemometer were used in making

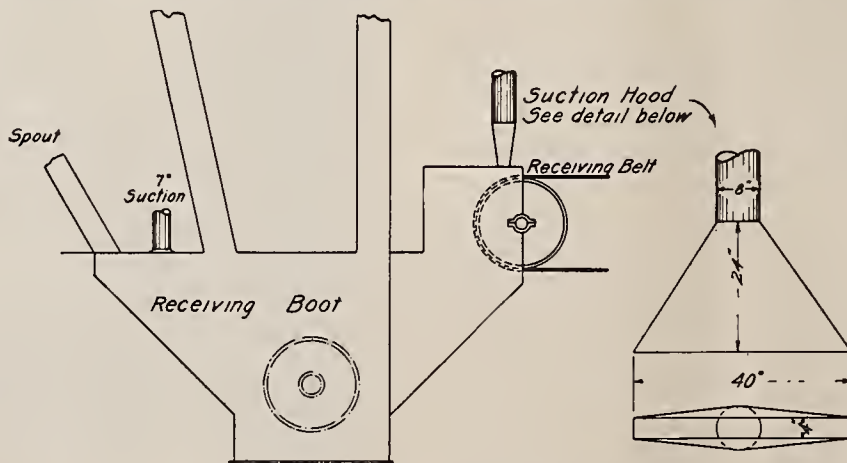

FIG. 2. SUCTION APPLIED TO RECEIVING BOOTS

the tests. A tachometer was used to determine the speed of the suction fans for computing the volume of air handled, because in many cases the speed of the motor had been changed, usually to provide greater suction at some distant point in the plant, so that the reading on the data plate attached to the motor was not correct. Sometimes the fans were driven by belts or silent chains and the tachometer was the only satisfactory method of determining the speed.

Concurrent tests were made at one of the elevators to determine the quantity of dust present in the air at various points² and other tests were made to determine the amount of suction neces-

sary to lift grain a given distance and the type of hood which will collect the maximum quantity of fine, light floating dust without lifting or removing from the grain any kernels or dockage heavy enough to materially affect the weight of the grain.

RESULTS OF TESTS OF DUST COLLECTING SYSTEMS

The following conclusions concerning the method of applying suction and the amount that should be used were drawn:

1. Suction should be applied through hoods or flared pipes rather than through a direct connection of the suction pipe.

2. Suction hoods should be designed to inclose as much as possible the machine or equipment producing the dust and should be so arranged that there is no possibility of grain or heavy material being thrown into the section of the hood or pipe line where the suction is stronger than it is at the intake.

3. No suction hood should be placed close enough to the grain stream to lift kernels or heavy particles of dust. This distance, of course, depends on the amount of suction maintained and the design of the hood. A velocity of 12,000 feet per minute will lift a grain of corn a distance of 1 inch or draw it to the intake over a smooth surface a distance of 2 inches. A velocity of 4,000 feet per minute will carry grain and dust in suspension within a pipe line. Thus, to prevent the picking up of grain it is necessary to reduce the velocity of the air at the point of application below 4,000 feet per minute.

4. Suction hoods should be so designed that the suction at the point of application is just sufficient to collect the light floating dust, while the air velocity in the suction line should be sufficient to carry the dust to the point of collection without allowing it to settle or collect in the pipe. An air velocity at the point of application of 1,000 feet per minute is sufficient to collect the light dust, while a velocity of 5,000 to 6,000 feet per minute is desirable in the pipe line. These figures indicate that a suction hood should be designed with an intake area of about six times the area of the pipe line.

DETERMINATION OF POINTS WHERE SUCTION SHOULD BE APPLIED

The lack of apparatus which will readily indicate the quantity of dust present in the air made it difficult to determine accurately all points where the quantity of dust escaping would be large enough to be dangerous. However, samples of air were taken at representative points and the dust content was determined by laboratory tests. From these re-

sults the relative quantity of dust present at other points in the plant was determined by observation. The maximum concentration of dust found with the apparatus in use was 620 milligrams per cubic meter and it is assumed that there are points where the dust concentration is 10 times as great.

These determinations and comparative observations in the plant visited indicate that when dusty grain is being handled dangerously large quantities of explosive dust arise at practically every point

¹ Dust Explosions. Price and Brown, National Fire Protective Association, Boston, Mass., July, 1922.

² Collection and Examination of Explosive Dusts in Air. L. J. Trostel and H. W. Frevert, Industrial and Engineering Chemistry, Vol. 15, No. 3, page 232, March, 1923.

where the grain is thrown or agitated. Suction is not necessary at all these points, however, to prevent the dissemination of the dust through the plant because the air currents traveling with the grain provide sufficient ventilation if some means of reaching the outside air is provided. At several points where suction was provided a natural vent would have served the purpose better and more economically. The points where quantities of dust were being disseminated through the plant are listed below. Each one is discussed separately, with reference to the dust collecting equipment used at these points or the method best suited to meet the requirements.

1. Unloading grain from cars.
 2. Discharge from track hopper to receiving belt.
 3. Discharge from belt to boot of receiving leg.
 4. Discharge from elevator head to garner.
 5. Discharge from garner to scale.
 6. Discharge from scale to distributing belt.
 7. Discharge from distributing belt to bin.
 8. Discharge from bin to shipping belt.
 9. Discharge from belt to shipper leg.
 10. Discharge from shipper leg to garner.
 11. Ends of conveyor belts or belt transfers.
1. Cars are usually unloaded outside of the elevator building or in segregated sections having thorough ventilation. The large clouds of dust produced in this operation do not remain long in

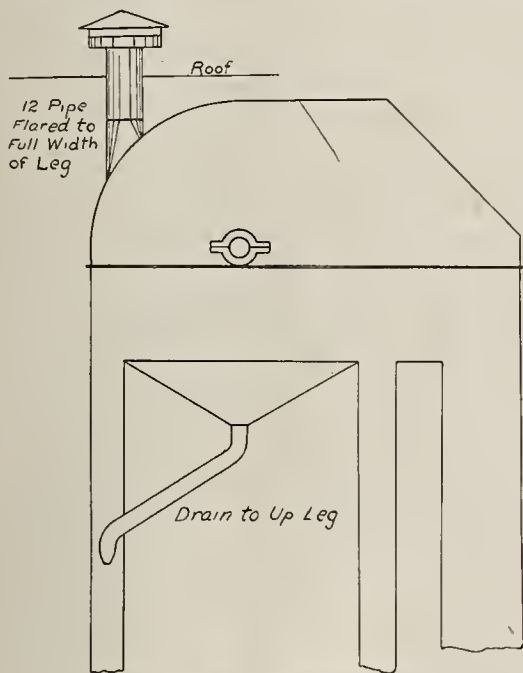

FIG. 3. ELEVATOR HEAD VENT

suspension. Unless the unloading is done in the main part of the elevator the use of suction at this point is not considered necessary. The principal step to be taken in controlling the dust condition is to see that the track shed is as open as possible and that there are no direct openings into the main part of the plant through which the dust can be carried by air currents.

2. When grain discharged from the track hopper strikes a swiftly moving conveyor belt clouds of dust are produced. Since this step in the handling process usually takes place in a tunnel or basement, the ventilation is poor and the dust remains in suspension in what is generally considered an atmosphere favorable for a dust explosion. The application of suction is essential here. It can perhaps be best accomplished by inclosing the receiving tunnel or the space around the bottom of the track hoppers and connecting a suction pipe to this enclosure. Such an installation, made by at least one elevator operator, seems to have been entirely satisfactory. Fig. 1 shows the arrangement of such an enclosure. While changes may be necessary to meet local conditions, it illustrates the method suggested for the control of the dust condition at the track hopper discharge.

3. As the grain leaves the conveyor belt and enters the boot of the receiving leg a cloud of dust usually arises about this part of the plant. Being in the basement, one of the most vulnerable spots of an elevator from the dust explosion standpoint, it constitutes a hazard. The application of

suction at the boot of the receiving leg seems to be the most logical remedy. The installation of a broad suction hood over the point where the belt discharges into the boot, with enough suction to lift only the light floating dust, will greatly improve dust conditions. A number of different methods for applying suction at this point are in use. In some cases a suction pipe is connected directly to the up leg, the down leg, the side of the boot, the top of the boot, or the spout feeding the leg. While all of the methods may be satisfactory as far as the removal of the dust is concerned, a chance to remove grain with the dust should the suction become too strong exists. A broad hood similar to the one shown in Fig. 2 seems to offer the best solution of the dust control problem at this point where the leg is fed by a conveyor belt. On the same drawing is shown a direct suction line connection for spout fed boot at what is believed to be the best point for the collection of dust with the possibility of collecting grain reduced to a minimum.

4. There are many methods for controlling the dust condition at the elevator discharge. A large quantity of dust is present in the elevator head when grain is being thrown from the buckets to the discharge spout. Some operators have applied suction to the head casing, while others have provided vents from the head to the outside of the building. Still other operators have kept the head casing and discharge spout tight and vented the garner into which the grain is being run. Tests made at the elevator head indicated both positive and negative pressure at this point, depending on whether or not the leg was in operation and whether or not grain was being elevated. When the elevator is not running the legs act as chimneys or flues and a decided up-draft from the boot to the head is usually found. When grain is being elevated the empty buckets descending carry more air than the filled buckets ascending. Consequently there is an inflow of air at the head to equalize this condition. With the leg running empty there is an outward flow of air through the head vent, but this flow is only about half as great as when the leg is not running. With grain flowing from the head to the garner through a closed spout the air displaced in the garner by the grain must escape somewhere. If no other vent is available it will flow back to the elevator head, either escaping there or being carried down to the boot by the descending buckets. This changing of the direction of flow of the air currents undoubtedly produces an excessively large quantity of dust in the elevator head and the alternate pressure and suction in time will open up cracks in the casing,

head vent is unnecessary, provided a sufficiently large vent is provided on the garner. Considering the value of the head vent as a means of ventilating the basement, however, its installation seems to be justified because the readings taken showed an upward flow of over 600 cubic feet a minute. For this reason vents on both elevator heads and garners are advocated as the most satisfactory method of controlling the dust condition at the elevator discharge.

5. The presence of dust on the scale floor of an elevator is particularly objectionable because of its effect on the scale mechanism and the accurate reading of weights. The grain entering the scale

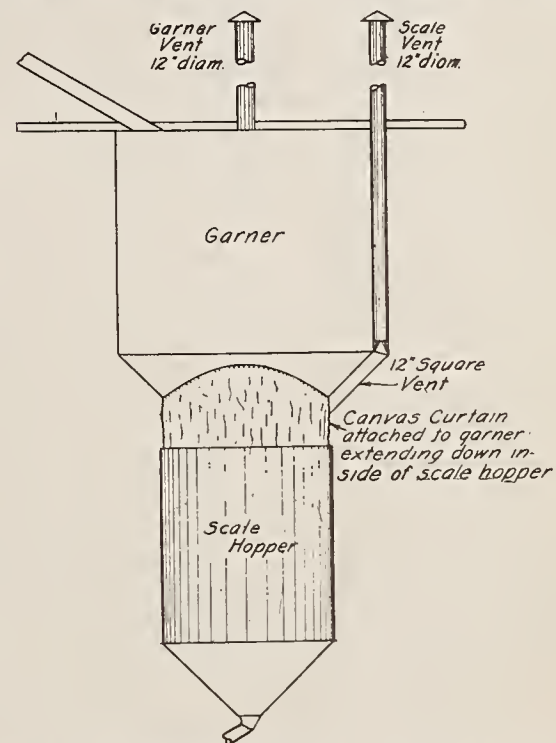

FIG. 5. ARRANGEMENT OF SCALE AND GARNER VENTS

hoppers displaces the air already there and this air, carrying large volumes of dust, will escape inside the building unless provision is made to vent it to the outside. It has become a general practice to inclose the space between the scale hopper and garner with a curtain and vent the enclosure or apply suction to it. Observations made at this point indicate that natural vents are proving satisfactory. The type of vent and curtain shown in connection with the garner vent (Fig. 5) is probably as compact an arrangement as can be made, although it can be varied to suit local conditions.

6. In some of the smaller houses it is possible to discharge grain from the scale directly to the

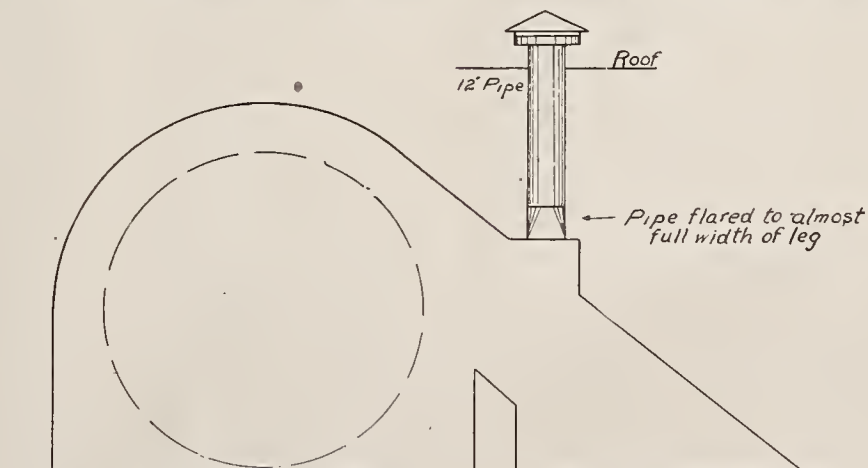

FIG. 4. ROOF VENT ON LOFTER HEAD TO SERVE BOTH LEG AND GARNER

thus permitting the dust to escape into the building. Obviously these conditions call for some air control apparatus at this point. Changing air conditions make it extremely difficult to maintain satisfactory suction on the head.

The natural vent, however, is a very satisfactory remedy for conditions at this point. Figs. 3, 4 and 5 show natural vents for elevator heads and garners. The tests showed that with vents at both points the flow of air when grain was being elevated was inward through the elevator head vent and outward through the garner vent. This indicates that as a dust control measure the elevator

storage bins. In the larger houses this is impossible, however, and conveyor belts with trippers are used. In either case the agitation of the grain at this point in the handling process stirs up the dust and some means of collecting it should be installed. If the discharge is direct to a bin the problem can be easily solved by venting the bin as described in the following paragraph, but if the grain is discharged onto a belt the problem of collecting the dust becomes more difficult.

The only installation considered suitable for collecting the dust at this point consists of suction
(Continued on page 349)

RAISINS AND WHEAT

BY JOHN J. STREAM
President Chicago Board of Trade

Co-operative marketing of farm products is a subject of wide interest in America. Innumerable organizations have been formed in recent years for the avowed purpose of improving the farmer's market. Many of these have been organized on the theory that they were superior to the established marketing machinery and therefore spelled greater success for the farmer in the shape of bigger financial returns.

Records of the Department of Agriculture show that a large number of these ill-advised co-operative ventures collapsed, failure overtaking 243 farmers' associations since 1913. Causes included insufficient business, inefficient or dishonest management, insufficient capital and too liberal extension of credit, according to the Department's reports.

The failures drive forcibly home the fact that co-operative ventures are not immune from the same difficulties that assail independent business. While the thought seems to prevail in certain communities that co-operative schemes are in some way superior to the efforts of the independent dealer and the present marketing system, the official records would clearly indicate that a co-operative organization is nevertheless subject to precisely the same ills and troubles that any other business must face.

Failures shown by the Department of Agriculture records do not constitute a happy record for co-operative marketing. Yet it would be utterly unfair and indicate a colossal lack of vision to condemn co-operative marketing simply because of the failures of the past.

On the contrary there is every reason to believe that the producer of many agricultural products can be distinctly aided through the adoption of co-operative marketing methods. This particularly applies to producers of perishable crops such as vegetables and fruits.

In this connection it should be stated that perhaps the greatest blunder ever made in co-operative movements is the present tendency to apply to grain and cotton the same marketing rules used in the handling of fruit. For conditions are as different as night and day.

There are many difficulties that must be overcome in the marketing of such agricultural specialties as oranges, raisins, prunes and apples. First of all it is necessary to create, or at least to stimulate, the demand. The world does not eat oranges or any other single fruit three times a day. Indeed the world could easily get on without any one particular fruit. There would be enough others to take its place. So the demand must be made.

It would be absurd for the individual fruit grower to attempt to create this demand. But it is wholly practicable for growers to band together and contribute to a general advertising and sales fund by which the product is kept in the mind of the public. As a result of such a course untold numbers of people who never cared for raisins or oranges could be induced to eat them. Doubling the consumption of a specific fruit may thus be attained. It simply means the creation of a demand and the building of a market that did not before exist.

Now let us contrast this co-operative fruit marketing with the marketing of wheat.

First of all, the demand for wheat does not have to be created. It already exists. It is world wide. It is an active and staple demand. The buyers of bread and flour are daily buyers. Unlike fruit, wheat does not have to be forced upon the consumer. In all lands the consumer wants it. Were all wheat growers to band together in a great advertising and sales campaign it would still be impossible to double the consumption of wheat as the consumption of fruit may be doubled. Consumption of wheat could of course be increased but only to a limited extent.

The whole matter simmers down to the fact that while the fruit grower must build up a special

taste for his product, the grain grower must simply fulfill the world demand. While the fruit grower has no regular marketing machinery, the grain grower has marketing machinery that has been built up by years of study and experiment; machinery that functions at a lower cost than exists in the marketing of any other staple foodstuff.

It is obvious therefore that to apply the co-operative fruit marketing idea to grain would simply mean the duplication of existing marketing machinery at a tremendous cost. And after this new machinery were built it would be found that it contained far more imperfections than had been anticipated.

If the farmers themselves would make a closer study of the question they would see the fallacy of likening fruit marketing to grain marketing. Fewer farmers would be tempted by the proposed pools and other economically unsound marketing schemes.

Farmers have been told repeatedly by the ill-advised organizer that co-operative grain marketing would greatly enhance the price. To the practical grain man or the student of marketing such talk is ridiculous. Should there be a successful movement by which wheat were pooled or stored and withheld from the market, any price advance resulting therefrom could only be temporary, for sooner or later the wheat would have to be sold. Moreover, if the wheat were held from market any length of time, it might bring disaster, for with unnaturally high prices an unprecedented wave of wheat growing would sweep the world. The subsequent glut of the market would inevitably bring ruinously low prices.

Wheat is a world product and must always be so considered. To increase the consumption of wheat or to control the price through such artificial means as pooling or withholding from the market is infinitely more difficult than the comparatively simple problem of marketing fruit.

Much has been said on the matter of "orderly marketing." Those sponsoring co-operative marketing schemes constantly stress the point that

wheat flowing to the market in large volume at harvest time depresses the price. They will tell you, too, that after the heavy grain movement season prices swing upward. Hence they favor marketing after the usual marketing season is over.

This misrepresentation of true conditions has been disproved many, many times in recent years. Surveys by disinterested authorities covering a period of half a century have shown that the farmer who sells at harvest time profits equally with the farmer who sells at a later season. The slightly higher margin received in later months will do no more than offset the cost of storage, insurance, shrinkage and other carrying charges.

Today the grain farmer has as complete and efficient marketing facilities as could be created if the soundest course of the co-operative movement were to be followed. The only possible result would be the complete duplication of the present marketing machinery, the high efficiency and value of which is becoming more and more apparent as the co-operative grain marketing schemes are studied.

There is indeed a vast difference between the co-operative marketing of raisins and the co-operative marketing of grain.

"SETTLEMENT IN FULL" CHECK

One of the arbitration committees of the Grain Dealers National Association recently decided a controversy according to common law and without reference to the trade rules.

The Beaverhead Milling Company of Dillon, Mont., failed to fulfill a contract for oats made to E. A. Webster & Co., and offered to settle. There was a disagreement as to settlement terms, but after considerable correspondence on the subject the milling company sent a check in a letter which contained the following paragraph.

"We have checked the matter of current values, with other dealers in touch with the oat situation on the coast, and are informed that \$40 to \$42 a

WHEAT CROP AND EXPORTS OF THE UNITED STATES

Year	Acres	Yield Bushels	Farm Value per Bu. Dec. 1st	*Exports Wheat & Flour Bushels	Share of Exports in form of		Population U. S.
					Wheat	Flour	
1880	37,987,000	498,550,000	95.1	186,322,000			50,155,783
1881	37,709,000	383,280,000	119.2	121,892,000			
1882	37,069,000	504,185,000	88.4	147,811,000			
1883	36,456,000	421,086,000	91.1	111,534,000			
1884	39,476,000	512,765,000	64.5	132,570,000			
1885	34,149,000	357,112,000	77.1	94,566,000	65.93	34.07	
1886	36,806,000	457,218,000	68.7	153,805,000			
1887	37,642,000	456,329,000	68.1	119,625,000			
1888	37,336,000	415,868,000	92.6	88,601,000			
1889	33,580,000	468,374,000	69.8	109,431,000			
1890	36,087,000	399,262,000	83.8	106,181,000			62,947,714
1891	39,917,000	611,781,000	83.9	225,666,000			
1892	38,554,000	515,947,000	62.4	191,913,000			
1893	34,629,000	396,132,000	53.8	164,283,000	59.50	40.50	
1894	34,882,000	460,267,000	49.1	144,813,000			
1895	34,047,000	467,103,000	50.9	126,444,000			
1896	34,619,000	427,684,000	72.6	145,125,000			
1897	39,465,000	530,149,000	80.8	217,306,000			
1898	44,055,000	675,149,000	58.2	222,618,000	59.03	40.97	
1899	44,592,000	547,303,000	58.4	186,097,000			
1900	42,495,000	522,230,000	61.9	215,990,000			75,994,575
1901	49,896,000	748,460,000	62.4	234,773,000			
1902	46,262,000	670,063,000	63.0	202,906,000			
1903	49,465,000	637,822,000	69.5	120,728,000	55.06	44.94	
1904	44,075,000	552,400,000	92.4	44,113,000			
1905	47,854,000	692,979,000	74.8	97,609,000	35.85	64.15	
1906	47,306,000	735,261,000	66.7	146,700,000	52.38	47.62	
1907	45,211,000	634,087,000	87.4	163,043,000	61.63	38.37	
1908	47,557,000	664,602,000	92.8	114,268,000	58.57	41.43	
1909	44,262,000	683,379,000	98.4	87,364,000	53.50	46.50	
1910	45,681,000	635,121,000	88.3	69,312,000	34.24	65.76	91,972,266
1911	49,543,000	621,338,000	87.4	79,689,000	37.85	62.15	
1912	45,814,000	730,267,000	76.0	142,880,000	64.11	35.89	
1913	50,184,000	763,380,000	79.9	145,590,000	63.65	36.35	
1914	53,541,000	891,017,000	98.6	332,465,000	78.11	21.89	
1915	60,469,000	1,025,801,000	91.9	243,117,000	71.33	28.67	
1916	52,316,000	639,886,000	160.3	203,574,000	73.60	26.40	
1917	45,089,000	636,655,000	200.8	132,580,000	26.25	73.75	
1918	59,110,000	917,100,000	204.4	287,438,000	62.20	37.80	
1919	72,308,000	934,265,000	215.1	219,881,000	55.69	44.31	
1920	61,143,000	833,027,000	143.7	366,077,000	80.11	19.89	105,683,108
1921	63,696,000	814,905,000	92.7	279,406,000	74.80	25.20	
1922	61,230,000	856,211,000	100.9	221,923,000	70.33	29.67	

*Years beginning July 1st and ending June 30th of the succeeding year.

—From Soil Products Bulletin, First National Bank in St. Louis.

ANSWERING A CRITIC

ton is the very best that they could hope to sell at (not bid us), and after figuring this thing over from all angles we are enclosing our check for \$225 to settle all differences between us and close the matter. You can suit yourself about cashing the check."

E. A. Baxter & Co. replied to this letter in part as follows:

"We have your check for \$225 which will be applied on the balance you owe us on cancellation of car oats. It will not, however, be accepted in full settlement as per the notation you have made on the check. We will not accept your basis of settlement under any circumstances."

The arbitration committee took into account only this check transaction, rendering the following decision:

"In the opinion of the Arbitration Committee the acceptance by E. W. Webster & Co. of the check sent it by the Beaverhead Milling Company, which check had indorsed thereon that the same was "in full for all claims demanded" constitutes full settlement of the claim. E. A. Webster & Co. at the time that they *received, accepted and cashed* the check was advised that the Beaverhead Milling Company offering the amount of the check in *full settlement for all claims*, and therefor it necessarily follows that the acceptance of this remittance constitutes a settlement of the claim. We therefor find in favor of the Beaverhead Milling Co. and against E. A. Webster & Co. and assess the costs of this arbitration to E. A. Webster & Company."

"JIM DUNN"

BY HOOZUS

Jim Dunn, who runs the elevator at Sperry Sid-ing, says: "About th' meanest fellers th' elevator man has gotta deal with, is th' ones that pile two or three crops on top o' each other, an' keep a' holdin' th' stuff—like Joseph did in th' Bible—for fear there's a' goin' t' be another seven lean years. When th' weevil gets so bad that th' whole gran-ary starts t' do a shimmy, then they begin t' think 'bout movin' it.

"Old Ai Sawyer is jest that kinda feller, an' th' other day he calls me up an' he says t' me, he says: 'Dunn! I've got two or three bins o' wheat that I'd like t' have you come out an' look at. I'm beginnin' t' think 'bout movin' it.'

"'Oh, ya are, are ya,' I says. 'Well, what d'ya want t' go t' that bother for? Jest tell it what elevator ya want it t' go t', an' it will move it-self. Ya gotta lot o' nerve, Ai, t' call that stuff wheat. Ya ain't got enny wheat out there,' I says. 'What ya got is a animated bran pile.'

"Ai, he hangs up madder'n a hatter, but th' next day, he starts his man t' haulin', an' I made th' price so low I felt like a thief, but when my returns comes in, blamed if I hadn't paid him 'bout 10 cents more'n th' stuff was worth, ennyhow."

LITTLE TIPS FROM JIM DUNN

Careful weighin' an' careless addin' is a bum combinashun. It's like takin' a lot o' pains with your writin' an' then lettin' th' blotter slip.

Lettin' weevil have a quiet time is bad for th' elevator man. Handle them like some women do their husbands. Make th' house unpleasant for 'em an' they won't stick around much.

A transmishun rope is like a man's conshuns. If it's wobbly it'll soon wear out. Keep it trued up an' it'll carry most enny load.

Th' elevator man that works th' hardest an' takes th' longest way t' do things, never reads a trade paper.

Ya'll save time if ya sit down an' think it out aforehand, 'stead o' layin' down an' swearin' it out afterwards.

Some elevator men know jest as much 'bout p'liteness as a pig does 'bout pie-crust.

Do a good job o' cooperin' your cars. It's a whole lot easier an' cheaper t' prevent a leak than it is t' get th' leakin's back from th' railroad afterwards.

Ya can do more in three minnits o' thinkin', than ya can in three hours o' thumpin'.

Eugene Meyers, managing director of the War Financing Corporation, recently made the state-ment that grain dealers have not done a solitary constructive thing for the producers. To this charge F. B. Wells of Minneapolis made answer. Mr. Wells offers no spectacular panacea for the situation, but he states some facts which all con-sidering the matter should keep in mind. Follow-ing is part of Mr. Well's answer:

If the grain dealers of the country have not made one constructive suggestion for the relief of the pro-ducers of grain, it is because their advice has not been solicited by the Government departments having this problem under consideration.

Farmers, lawyers, merchants, bankers, political economists and politicians—principally politicians—have been called to Washington to offer suggestions for the relief of the wheat grower, but the grain trade, which is so closely in touch with the grain situation and so intensely interested in marketing problems, have not been asked for information or for suggestion. As a consequence of this, the views of the grain trade on this serious economic problem have not come to public notice.

If the grain trade were to be asked for its ideas as to what is to be done for the wheat farmer, their reply would be based upon sound economic principles and would not be tinged by any thought of political expediency.

The grain trade of this country is not opposed to co-operative marketing. As I have before stated, the trade believes that, subject to certain limitations and under well defined conditions, co-operative marketing affords a very valuable means of distribution, but the grain trade is opposed to any movement tending to build false hopes in the minds of the wheat producers of this country, and it is firmly of the belief that no system of marketing can alter materially the price level of wheat in this country. Twenty-five per cent of our wheat crop is available for export. The price obtainable for this surplus in the world's market determines the domestic price of the entire crop. The cost of raising this surplus is materially in excess of the cost of competing offerings of wheat. The farmer in the United States cannot raise wheat profitably for export in competition with low cost pro-ducting countries, where labor and land values are materially lower and where the standard of living is such as would not be tolerated by our agricultural population. Under these conditions, it is obvious that the solution of the wheat farmers' troubles lies in the reduction of production until it reaches a proper relation to domestic consumption and the main-tenance of an import duty sufficiently high to bar out importations of wheat.

If the grain trade were asked to make recommen-dations for the relief of the wheat growers' situation, I believe that their reply would be to raise the im-port duty on wheat to 50 cents a bushel to protect our producers against an avalanche of wheat from the Canadian Northwest, and, at the same time, start an intensive campaign for the reduction of wheat acreage, particularly in those sections of the coun-try which during and since the war have increased their acreage to a very great extent over that under cultivation in wheat prior to 1914. Any movement which tends to enhance the price of wheat in this country artificially will inevitably increase the pro-duction, and, in the long run, the position of the wheat farmer will be worse than it is today.

You can not lose sight of the fact that the compe-tition in the world's wheat market will unquestion-ably be more keen as years go on than it is now. Russia is rapidly coming back to production. The Argentine is increasing its acreage. Canada has tre-mendous untilled areas suitable for the production of wheat, and, owing to its higher yield per acre, can raise wheat at less cost than the United States.

It is claimed that the so-called orderly marketing resulting from co-operative organization is of im-mense benefit to the producer. This unquestionably is true in the case of commodities for which no well organized marketing machinery exists, but the present machinery for the marketing of wheat has accom-plished all that the advocates of orderly marketing desire, as is evidenced by the fact that over a period of 59 years the average price of wheat during the months of heaviest marketing, as compared with the average price during the months when the stocks are practically depleted, shows a difference of barely enough to pay the cost of carrying the grain—i. e., interest, insurance and storage from the period of the peak movement to the period of supply exhaus-tion.

As regards the cost of handling grain under the existing marketing system and under the co-opera-tive system, co-operative costs covering a period of years are not available, but it can be stated without fear of contradiction that for the last 15 years the gross cost of handling wheat from the producer to the terminal market under the existing system has not, on the average, exceeded 5½ cents a bushel, while such reports as are available from various pool operations indicate a total handling cost of from 11 to 15 cents a bushel. Obviously, no economy in the

cost of handling can be anticipated from co-opera-tive organization. That there are advantages in the organization and operation of local associations is not to be denied, but these advantages are largely educational and however desirable do not tend to change the economic position of the wheat farmer. The same is true with regard to the organization of co-operative sales agencies at the terminals and the grain trade offers no opposition to either of these forms of co-operative activity. There is no disposition on the part of the grain trade to scoff at any innova-tion in marketing, but, in all fairness, it is wrong to hold out to the farmer the prospect of securing a better price for his wheat through co-operative mar-keting based on the record of such success as has been attained in the marketing of specialty crops through co-operative organization.

The acreage seeded to wheat in 1922-1923 was 11,-000,000 acres greater than the average during the prewar years 1909-1913. If this land could be returned to the uses for which it was formerly employed, and the duty on wheat be raised to, say 50 cents per bushel, the problem of the wheat farmer would be solved and there would be no distressing after effects which would inevitably result from a change in the system of marketing or from inflation in price as the result of operations which are economically unsound.

As regards any service rendered by the grain trade to the producer, I would call attention to the fact that the grain trade, in connection with the milling trade, were the pioneers and financed the campaigns for seed improvement and rust eradication; that, whenever any section of the country has suffered seri-ous crop disasters, the grain trade has come forward with large donations for relief, and that, through the efforts of the grain trade and because of their finan-cial assistance over 50 per cent of all the local grain elevators in the Northwest are owned, controlled and operated either by farmer elevator companies, co-operative companies, or local independent dealers.

The importance of an increase in the import duty on wheat should be apparent to all. The northwest markets are now practically on a basis which permits of the importation of Canadian wheat, and action should not be delayed. If the authorities in Washing-ton wish the advice, suggestions and co-operation of the grain trade, it is theirs for the asking.

NORTH DAKOTA WHEAT POOL STATEMENT

Saving money by co-operative marketing as ad-vocated by Eugene Meyer, Jr., and other theorists received another severe setback when the North Dakota Wheat Growers Association issued to its members a statement of the operations of its wheat pool in 1922. A total of 2,981,763 bushels of wheat from 3,000 members was pooled and the charges for handling are itemized as follows:

	Per Bu. Cents.
Direct charges—	
Interest paid banks.....	1.2
Elevator handling and storage.....	5.8
Terminal handling and storage.....	1.7
Farm storage	1.9
Insurance and taxes.....	0.2
Total	10.8
Operating charges—	
Administration expense	1.0
Office upkeep	0.6
Supervision and statistics.....	0.6
"The Producer"	0.1
Maintenance of Duluth and Minneapolis offices..	0.5
Total	2.4
Reserve withheld	0.5
Grand Total	13.7

This statement is about in line with that of the Pacific Northwest Pool. Independent dealers han-dle wheat on a margin of about 5½ to 7 cents a bushel at country elevators which includes terminal weighing, inspecting and hedging. That margin is all the farmer is concerned with and is, for him, the cost of handling wheat. It will take a lot of talk by Mr. Lowden and his cohorts to persuade the farmers to pay \$10 per, for the privilege of taking a cost margin of 13.7 cents a bushel for handling his wheat instead of 5½ cents. If the farmers still fall for it they sure are gluttons for punish-ment.

ILLINOIS has an electric interurban system with 555 miles of track and 40 grain elevators directly on the lines of the company.

THE Western Terminal Elevator at Fort Wil-liam, Ont., recently loaded 130,000 bushels of wheat into the hold of the S. S. Brown in 60 min-utes. This constitutes a record at the Head of the Lakes, and if any port has exceeded it we should like to hear of it.



Published on the Fifteenth of Each Month
BY

Mitchell Brothers Publishing Co.

OFFICE:

Manhattan Building, 431 South Dearborn St.
CHICAGO, ILL.

A. J. MITCHELL.....Business Manager

Subscription Price - - - - \$1.00 per Year
English and Foreign Subscription 1.75 " "

ADVERTISING.

This paper has a large circulation among the elevator men and grain dealers of the country, and is the best medium in the United States for reaching persons connected with this trade. Advertising rates made known upon application.

CORRESPONDENCE.

We solicit correspondence upon all topics of interest connected with the handling of grain or cognate subjects.

Official Paper of the Grain Dealers National Association and of the Illinois Grain Dealers Association

CHICAGO, ILL., NOVEMBER 15, 1923.

NO SENSATION IN THIS

AFTER traveling thousands of miles and holding innumerable conferences, Eugene Meyer, Jr., and Frank W. Mondell, both of the War Finance Corporation, reported on November 4 to President Coolidge that the solution of the wheat farmers' problem lies principally in reducing wheat acreage and the orderly marketing of wheat through co-operative agencies. The report also touches upon the tariff, immigration, freight rates and reduction of taxes, but the two points first mentioned were particularly stressed. This was rather disappointing to those who expected something sensational enough to boost prices skyward.

The recommendation for co-operative selling agencies is made in the usual vague way, which suggests the striving for political effect rather than an honest advocacy of an economic program. The Government price fixing plan is thoroughly discredited and it is hoped that the report will put a quietus on it when it is brought up in Congress in December.

The really constructive part of the report, that dealing with the labor problem and immigration, will have less attention from the politicians than any other unless the farmers join in making a real issue of it. A reasonable adjustment of farmers' returns for their products and the prices they pay for necessary commodities can not be made so long as labor retains its strangle hold on the economic forces of the country.

So far as can be judged from the outline of the report, it could easily have been made

without the travel, without the publicity, and without arousing hopes which were destined to disappointment. But, of course, that is not the official way of doing things at Washington.

A PROBLEM FOR CONGRESS

ON NOVEMBER 1, Representative Sydney Anderson of Minnesota formally filed an application with the Tariff Commission for an increase in the duty on wheat to 50 cents a bushel. In the brief accompanying the application Mr. Anderson stated that the acre yield in the prairie provinces of Canada was 20.6 bushels per acre, while in our Spring wheat territory it was 9.5 bushels. Assuming that the cost of raising the wheat is the same in both countries, \$15 per acre, the cost per bushel in Canada is 72 cents and in the four Spring wheat states, \$1.67. The cost on both Spring and Winter wheat in this country would be \$1.30, assuming the same per acre cost. A 50-cent duty would not quite meet the difference in cost of production, nor would it take care of a rail rate advantage of 2½ to 3 cents which the Canadian farmer enjoys.

There are two factors upon which nearly everyone is agreed are essential to permanent relief for the farmer: One is a smaller wheat acreage; and the other, lower cost of those things which the farmer has to buy.

Senator Capper suggests a lowering of the tariff on the articles the farmer buys. Every practical politician and those who have watched the log-rolling tactics of congressmen, need not be told that it is a difficult matter to raise the tariff on one article and at the same time lower it on others. Representatives with wheat consuming constituencies would be heard from on one hand, and the spokesman for the manufacturer on the other. And certainly a high duty would not induce a decrease in wheat acreage.

It would take Congress an entire session to strike an economic balance between Mr. Capper's suggestion and Mr. Anderson's, if it did nothing else. Unfortunately it will not confine its activities to this problem, and in its haste will undoubtedly do many foolish things as it has in the past.

THANKSGIVING

WE HAVE reason to give thanks that some of the members of the Canadian Parliament chose the Dominion as their abiding place instead of the United States. If they had come here instead they would probably be in Congress, and Washington already has enough of their kind without them. So let us celebrate Thanksgiving with grateful hearts.

Here is what it is all about. The Canadian Parliament listened to the outcries from farm agitators in the West that grain rates on the Great Lakes were too high, and passed a law known as the Inland Waters Freight Rates Act, which provided, among other things, that vessel owners file a schedule of rates prior to chartering and provided for certain fines if the law were not obeyed. American

vessel owners refused to carry Canadian grain under the new law, with the result that western growers couldn't move their grain to sea-board. More outcries from the farm leaders! Backwater by the Canadian Government which told American vesselmen to go ahead and forget about the law. American ship-owners, mindful of the possible fine, ask shippers to guarantee them against penalties and incidental losses. Shippers in turn demand that the Government pay them for any fines or losses reimbursed by them to the vessel owners. So if the Government wants action it will have to pay its own fines. And sometimes members of Parliament, as our own Congressmen, are referred to as "statesmen!"

MORE CORN

NOVEMBER is the month for the corn crop report which indicates final output. The Government report this month gives a corn estimate of 3,029,192,000 bushels, or 8,000,000 more than was indicated last month and 138,000,000 bushels over last year. To be sure there is a great deal of light corn from frost, and a high percentage of moisture, but reduced to dry, sound weight, this represents a lot of corn.

The balance of the report shows few changes from that of last month, so a mere recapitulation is called for: Wheat, 781,737,000 bushels; oats, 1,302,453,000 bushels; barley, 199,251,000; rye, 64,744,000; hay, 102,914,000 tons; flaxseed, 19,343,000 bushels, rice, 32,737,000 bushels; grain sorghums, 103,506,000 bushels; Clover seed, 1,121,000 bushels. The stocks of old corn on farms November 1, were estimated at 83,357,000 bushels, less than half those of last year.

ANOTHER PLAN

ONE distinct advantage is contained in the Gould plan for relieving the wheat farmer. Its provisions are concrete, clear cut and provide a basis for a discussion which may get us somewhere. Probably no group will agree on the plan in its entirety, and before we get through none of its provisions may prove wholly acceptable, but at least it is better than the vague co-operative plan of Eugene Meyers and most of the other corrective measures that have been proposed.

An increase in the duty on wheat is the first provision. This sounds simple enough, but we have found through bitter experience that any tariff tinkering has far-reaching consequences and is, in fact, a most complex problem. An increase in wheat duty would doubtless lead to retaliatory measures from Canada and our exporters to that country would be up in arms. There is also an ever present threat of an embargo on Canadian wood pulp upon which our paper mills are dependent. There are countless angles to even this first provision.

The division of the wheat to be exported and whether it should be exported in the form of grain or flour, are also questions which need a great deal more discussion than has been given to them. The millers are crying aloud for the chance to mill 50,-

November 15, 1923

000,000 bushels of wheat for export. The industry needs the business for there is as great an excess of milling capacity in the country as there is of wheat, and competition, much of it ignorant, has forced flour prices to the point where there is no money in it for anyone. And if wheat is to be exported, it might as well be milled in this country; consumption of wheat is just as certain, and there would remain about 15,000 tons of much needed mill feed. We are a long way from agreement in any case.

CONTROLLING PESTS

SIMPLEST measures are often the most effective. Leading scientists all over the world have been studying the control of the cotton boll weevil with only indifferent success. And then along comes a tenant farmer in Georgia who planted two 4-acre tracts to cotton and in the middle of each tract he put up a chicken house with about 20 hens in each house. The profit from his hens paid for the entire crop and the cotton went a bale to the acre, all velvet. It seems that chickens like weevils. In this case, at least, they kept them under complete control, although in a highly infested district.

It is estimated that chinch bugs did \$50,000,000 worth of damage last year, and yet they can be controlled by burning dried grass and trash around fields if entire neighborhoods unite in doing it. This is almost as easy as keeping chickens, although not so profitable in itself. It is worthwhile, however, and the Southwest Wheat Improvement Association will do a big thing if it can make the practice general.

THE ALBERTA POOL

THE wheat pool, organized by Canadian growers in Alberta, began operations on October 29. About 1,000,000 bushels will be handled by the pool. A similar pool proposed for Saskatchewan failed of securing the required number of signers, but Alberta refuses to allow those who did sign to make use of the Alberta pool facilities. Thus do co-operators co-operate.

The governors of the Alberta pool advance growers 75 cents a bushel, less freight and handling charges. The rate from Calgary or Edmonton to Vancouver is 13½ cents per bushel, and to Fort William about 15 cents. As the ocean rate from Vancouver to Liverpool is 23 cents and from Fort William 15 cents, the Fort William route has the advantage by over 6 cents so Fort William will doubtless be used as the basic point. With a freight rate reduction of 15 cents from the 75-cent advance and a further reduction for handling charges, Alberta farmers will get an advance of only about 55 cents and may wait a year for the balance, if there is any balance. On November 2, cash wheat, No. 1 Northern, brought 98¾ cents at Fort William. This would net the independent Alberta shipper about 80 cents a bushel spot cash.

The pooling experience for Alberta farmers will be rather costly, but it will prove highly

educational, not only for Canadians, but for the deluded disciples of Sapiro in this country.

PROPOSED LEGISLATION

AS IS customary with professional politicians and demagogues the representatives of the farming states have announced in advance what they propose to do in the way of securing legislation for their constituents. This is the off season, so the proposals make more noise than they would later. Here is the list of things that Senator Capper gives as the farm bloc program:

- Reduce freight rates on farm products.
- Give every encouragement to co-operative marketing.
- Revise tariff further downward on farmers' necessities.
- Enact the truth-in-fabric bill.
- Make further reductions in appropriations.
- Draft new program of public expenditures to lighten tax burden.
- Accept Henry Ford's offer to develop Muskegon Shoals.
- Encourage early development of Great Lakes-St. Lawrence waterway.
- Enact a soldiers' bonus.
- Provide a constitutional amendment prohibiting further issues of tax free bonds—Federal, state and municipal.

Congress must see to the vigorous enforcement of the liquor laws and permit no amendment to the Volstead Act that will weaken it. There can be no backward step in the enforcement of prohibition.

The Farmers National Council has another list, which also gives us something to think about:

- (a) Creation of a Government marketing corporation to buy farm products and sell them here and abroad.
- (b) Crop insurance under which farmers will contribute at least something to the cost of insuring their own crops.
- (c) Government marketing credit, which will give the farmers credit upon as good terms as any other equally responsible industry secures.
- (d) Operation of railroads as a unified Government system for service and not for speculative profit.

Congress will also be asked to investigate charges that Secretary of Agriculture Wallace failed to prosecute commission firms for flagrant robbing of farmers.

Warren S. Stone, grand chief of the Brotherhood of Locomotive Engineers, promised the farmers aid of the railway men's organization in securing relief legislation in the new Congress.

The latter list is frankly Socialistic and would give us little concern if the present Congress contained even the average of brains and balance. Senator Capper's list is a strange mixture of constructive ideas and vote-catching phrases. About half the program can be endorsed without hesitation, but we could not vote for the other half even to secure the relief which the better measures contain.

FLAX AND WHEAT

NORTHWESTERN states, Minnesota, North and South Dakota and Montana had a wheat acreage this year of 17,437,000 acres and the country is crying because of our great wheat surplus. The flax acreage for the same states was about 2,000,000 and the production is estimated at 19,036,000 bushels of flaxseed. But instead of this rep-

resenting a surplus it is estimated at less than 50 per cent of the requirements of the country. On October 2 the highest price realized for No. 1 Dark Northern wheat at Minneapolis was \$1.24½ per bushel. On the same day flax brought as high as \$2.56½. The average yield of Spring wheat this year was 12.8 bushels per acre and for flax, 8.5 bushels, so the returns per acre are about 25 per cent better for flax.

Because of these facts the Department of Agriculture is advocating the increase of the flax acreage at the expense of wheat, not as a perpetual crop, but as having a place in rotation. But neither flax nor wheat are constant factors, and at all times the world supply and demand must be watched and the procedure regulated accordingly.

ORDERLY MARKETING

SO OFTEN has the phrase "orderly marketing" been repeated that it has become a mere symbol of discontent and means nothing to those who use it. The Department of Agriculture has found that 62.1 per cent of the marketable surplus of the wheat crop moves during the four months of July, August, September and October. During the same months, 49.8 per cent of the oats crop. The corn crop moves later, 47.2 per cent of the surplus moving in December, January, February and March. About 51.9 per cent of the barley moves in the first four months after harvest, and 67 per cent of the flax is harvested in the last four months of the year. This average covers the five-year period from 1917 to 1922.

There is a reason for this early marketing of crops, other than the mere fact that farmers need money at harvest time to pay obligations accumulated during the growing season. There are always farmers who are hard up, and these account for a part of the early marketings. But during 1917 and 1918 the farmers were not hard up and yet the proportional marketings were not far from the average. David Friday, formerly president of the Michigan Agricultural College, recently stated, in an extremely thoughtful and comprehensive article which appeared in *Trade Winds*, that the value of farm products from 1899 to 1922 kept well ahead of non-agricultural commodities, so that during the long period the farmer was better off than any other industry taken as a whole. During all this time the bulk of the grain crops has been marketed in the four months after harvest.

There are two reasons: It has been found that over a period of 40 years the prices obtained for wheat at harvest time were as high, carrying charges considered, as could be obtained later in the year. In the meantime, the farmer had the use of his money, and experience taught that harvesting from the thresher was the most profitable. It is also a fact that the world movement of wheat as shown by exports from all countries is about equally divided between the four seasons; the fall season belongs to this country and Canada. If we should hold back export sales during this period we would run into competition from the Southern Hemisphere. In

fact all the elements at hand indicate that we have been marketing our grain in the most orderly manner possible and that when the farmers get through flirting with easy credits and expensive pools, we will continue the old orderly manner.

EDITORIAL MENTION

Great Britain has inaugurated a policy of Empire tariff preferences in many commodities, but wheat will not be among them.

What seems to be the matter? There hasn't been a report on grain marketing from the Federal Trade Committee for over a month!

Bootlegging wheat over the Canadian border is said to be one of the favorite outdoor sports in the Northwest. For the sake of the rum-runners at Ecorse, Detroit papers please copy.

The rice futures market opened at New Orleans on November 5. Rice has become an important grain (in 1920 over 32,000,000 bushels and 1921 over 35,000,000) in this country and needed the stabilizing effect of future trading operations.

In 1913 Germany produced more wheat and rye than in any year of its history; 171,075,000 wheat and 481,169,000 bushels of rye. This year there are 103,604,000 bushels of wheat and 282,452,000 of rye. This is a potent argument for peace.

It is estimated that about 6,000,000 bushels of Canadian wheat has been imported by American mills for grinding into domestic. The millers claim that the quality—price of Canadian wheat represented a saving of from 8 to 10 cents as compared with American elevator wheat.

The Wheat Council of the United States met in Chicago this week. After sharpening its pencil and doing some figuring the Council announced that American farmers must reduce the wheat acreage from 62,000,000 to 50,000,000. But the Council didn't say which farmer should do the reducing.

One of the bankers of North Dakota who was in the Washington delegation to advocate Government stabilization of wheat prices at \$1.70 per bushel, invited some suspicion of his motives when he said: "Foreclosures are so numerous as to constitute a menace." We wonder whether the bankers are looking for protection for the farmer or for the paper held by the banks.

We used to think that revision of the Spring wheat grades was a matter of political expediency with O. P. B. Jacobson of Minnesota, but we have recently concluded it is merely an obsession. Mr. Jacobson just got back from Europe, and he claims that our Spring wheat is discriminated against over there on account of the Government

grades. Europe doesn't buy much of our Spring wheat, it is true, but not because of the grades. Europe has to compete for it against American millers and the latter pay higher premiums for the better grades than Europe will pay, so they take Winter wheat instead, or else buy in Canada.

For the four months, July-October, our reports of all grains are less than a third of last year, 57,464,000 and 189,329,000 bushels respectively. The greatest loss was in corn which dropped from 46,171,000 last year to 3,501,000 bushels this year. Wheat shipments are 41,000,000 bushels less this year than last.

Our crop reporting system by the Department of Agriculture has come in for a lot of criticism lately, not only from grain producers and dealers, but also from the cotton interests. French crop reports are similarly criticized by growers in that country. There would be far more criticism if we had no reports.

The North Dakota Press Association has asked the farmers of the state to adopt the slogan: "Forty Acres Plus," meaning that no less than 40 acres of forage crops be grown on every farm. Let the wheat farmer beware. The first thing they know these unfeeling editors will be wanting them to work every month in the year.

A movement is on foot to divide the great ranches in the Texas Panhandle and western Oklahoma into small farms devoted to diversified farming. The cotton acreage will be the chief gainer, but it is predicted that wheat production will be increased about 7,000,000 bushels. We don't need the wheat, but we do need the diversified farms.

Russia is planning to export large quantities of grain this year, in spite of the fact that outside agencies still find it necessary to feed a large number of Russians. If the foreign credits obtained were spent in constructive betterment of home conditions there would be little criticism, but we are curious to know how much of those credits are expended in Bolshevik propaganda.

One of the arguments for pooling, advanced by Eugene Meyer, is that Europe is now buying from hand to mouth instead of contracting for large amounts of grain in the fall. European dealers are afraid of large commitments on account of exchange fluctuation. He did not explain how the pools could take advantage of this situation without the aid of Government financing. It seems rather a situation in which the utmost encouragement should be given to speculation so that the cost of carrying the grain could be spread over as large a number as possible.

Senator Capper seems concerned that 600,000 American farmers will be compelled to abandon agriculture as a means of livelihood and to seek employment in the cities. What is all the fuss about? At present city wages the 600,000 will make more money than they have been making; there will be that many

more mouths to feed for the farmers that remain on the farms; production will be decreased; and another step toward the adjustment of farm prices will be taken. Senator Capper should rejoice rather than grieve. But perhaps he will lose some subscribers for his farm papers; then it is a tragedy indeed.

W. W. Felson, auditor of Pembina County, N. D., has written a personal letter to President Coolidge, advocating the prohibition of mortgages on farms, and the invalidating of taxes on farmstead acreage of more than 50 cents. Why not start with the latter suggestion, then the farmers wouldn't have to mortgage the farm to pay taxes at any rate.

When the American Wheat Growers Association met at Denver on November 1, in conference with Mr. Meyer and Mr. Mondell, it was predicted that epoch making decisions would be rendered. The meeting adjourned after passing a resolution to raise the duty on wheat, and appointing a committee of four to act with Mr. Lowden's committee to sign up more 10-dollar farmers. The epoch turned out to be just another day.

Some days ago a suggestion appeared in the public press that the Chicago Board of Trade suspend future trading for a year or so in order to demonstrate the real value of an open market. There is no question but that the value would be demonstrated, but the cost would be great and it would not be keeping faith with those who depend on the Board for the safe conduct of their business. The suggestion is not to be taken seriously.

A farmers elevator at Lakefield, Minn., brought suit against a former manager to collect several thousand dollars which the manager lost in the conduct of its business. It is alleged that he speculated. The manager asserted that the directors of the elevator knew of his speculations and approved them so long as he made money. The jury acquitted him. The moral of this is: Always be on the right side of the market when you speculate.

In a report on wheat grades to the state legislature, Representative O. C. Neuman of North Dakota, solemnly stated: "If at the present time the farmers would get their just price, and I believe that it is about 20 cents per bushel more, if we eliminate all unreasonable overhead charges and juggling of the market, I think you will agree that the price then would not look so bad." What can you do with a state whose representatives make such statements.

Officers of the American Wheat Growers, Inc., deny that their organization will be absorbed by the one represented by the Lowden committee. If the two organizations try to get members in the same states, the competition might lead to price cutting, and the U. S. Grain Growers have already shown us that it costs more than \$10 in some states to get the signatures. If they are not careful forming pools will soon become unprofitable for the organizers.



W. H. TOBERMAN
St. Louis

NEWS OF THE TERMINAL MARKETS



GEO. S. BRIDGE
Chicago

KANSAS CITY BOARD OF TRADE TESTS TO GOVERN

A resolution was recently adopted by the directors of the Kansas City Board of Trade that as no official laboratory had been established by the state of Missouri, adjustments would be based on Kansas State Grain Inspection Department laboratory tests.

HAVE WORKING AGREEMENT

A conference was held in Cleveland, Ohio, October 25 between the United States lake steamship managers and Chairman Leslie H. Boyd and Commissioner Snow, of the Board of Grain Commissioners of Canada, at which an agreement was reached that the filing of charters or contracts for space will be sufficient thus bringing to an end the controversy which resulted from the passage of the lake freight act in Canada.

HAS ARRIVED IN EUROPE

Philip Rothrock has notified friends that he has arrived in London and started on the work laid out by the Department of Agriculture. Mr. Rothrock has been for the past seven years Federal grain supervisor at St. Louis. He was sent to Europe by the Department of Agriculture to investigate and report on alleged differences between grain trading at American export ports and receiving terminals in Europe. He expects to visit all the leading grain handling ports of Europe.

WILL AID SHIPPERS ON FREIGHT CLAIMS

The St. Joseph Grain Exchange is lending its aid in assisting shippers of grain tributary to St. Joseph, in securing reparations on shipments handled by railroads during the period October 20, 1921, to January 1, 1922. This activity is due to a decision rendered in the lower courts awarding refunds on freight held to be excessive during the foregoing period.

The Transportation Committee of the Exchange and the Traffic Department are securing assignment of claims from shippers of grain and will handle them as one suit.

TRADE WAITS ON WASHINGTON

Wheat will likely mark time until official action one way or another decides the trend. Domestic and export trade are bound to put on brakes awaiting definite news. The flood of bearish news that has covered wheat has put it in position to respond quickly to most anything constructive.

As we see it there is a whole lot of talk, but nothing forceful being done to boost wheat prices. Everyone appears nervous and fearful of getting on the wrong side of the market. When something actually helpful appears on the wheat horizon sentiment ought to quickly form on the bull side.—*Southworth & Co., Toledo. Market letter of November 10.*

NEW CORN TAKEN READILY

Receipts of corn here recently have been very light and, in consequence, prices have been advancing. Arrivals of old corn have just about ceased and all the new corn arriving has been taken readily by industries. Shippers have also been good buyers of the better quality corn. A large proportion of the new corn sent to elevators has been run through dryers, although this has not been entirely satisfactory on account of the excess moisture in so much of the corn arriving. There are occasional cars of No. 4 and No. 5 corn among daily receipts, but the biggest portion grades No. 6 and sample. The movement from the country has been retarded recently on account of farmers being busy

husking, but we understand in a good many places this work has now been completed. Industrial demand here continues active and indications are now that this will increase as new plants are beginning to operate. The demand for shipment has been good, but it is difficult to make corn which is suitable for shipment out of the class of corn that has been arriving here recently.

Receipts of oats have been light and values here have been in line with those in other markets. The country is disposing of them sparingly, and as the new corn receipts increase, we look for much lighter arrivals of oats. There seems to be a good demand for them from southern markets.—*Mueller Grain Company, Peoria, Ill. Market Letter of November 12.*

A LEADING CHICAGO GRAIN MERCHANT

We present in this department, this month, a grain merchant of Chicago who needs no introduction to the general grain trade. On the contrary, the acquaintance and friendship of "Dolph" Ger-



ADOLPH GERSTENBERG

stenberg is widely shared. No grain dealer or man of any professional character can walk among his fellow men for 49 years or less without pegging a few holes which designate his character. Particularly also if his walk is among the grain trade, for the light shines about as brightly there as it does upon the proverbial throne. So we are enabled to give in this brief sketch a few of the salient points in the life of Mr. Gerstenberg, knowing that it will prove interesting to his friends, and that the facts set forth can only result in added respect for the man.

First, Mr. Gerstenberg is associated with his brother Erich in the ownership and management of Gerstenberg & Co., of Chicago, a thriving grain firm which does business through central and western territory. He was born on the north side of the river in Chicago, on December 29, 1860. The particular place was at the corner of Huron and Market streets and this neighborhood in those days was given over to the first families of Chicago. Later his parents moved to Dearborn avenue, then the leading residential street, and this home property was destroyed in the great fire of 1871. It was later rebuilt and was not disposed of by the heirs until 1920 so that it remained in the family without change in the title for a period of 60 years. It was located a short distance from the site of old Fort Dearborn in the old original 160 acres, one of the first subdivisions of the original city.

Mr. Gerstenberg's father, Charles Gerstenberg,

was one of the original members of the Chicago Board of Trade and was engaged in the commission business handling all kinds of farm products. This included in those days, grain, seeds, dressed hogs, meats, hides, wool, butter, eggs, potatoes, vegetables, etc., etc. The business was located on Kinzie street, which at that time was the principal produce market.

After graduating from Dyenforth College located at Randolph and Clark streets, where the boys played between classes in the court house yard adjoining, young Gerstenberg at the age of 15 entered his father's office and learned every department of the business. When the father died on May 5, 1879 the sons took over the business which was operated as Gerstenberg & Co. In 1884 when the Chicago Board of Trade moved to its present location at the head of La Salle street, the produce department was discontinued and the business was removed to Adams and La Salle streets but two years later it was moved to the present location opposite the Board of Trade at 305 South La Salle street.

Mr. Gerstenberg has had an enviable and useful career during his membership in the Chicago Board of Trade. He served as director in the years 1912-13-14 and has been continuously each year on one or more committees since 1884. He is at present chairman of the Grain Committee of the Board of Trade on which he has served for upwards of 15 years. He was a member of the Arbitration and Appeals Committee for six years and the reputation he made in this department of the Board's activities resulted in his being chosen by the Grain Dealers National Association as chairman of their Arbitration Committee on its establishment as a feature of that organization. During the period of his chairmanship no decision ever given by the Arbitration Committee was ever reversed by the directors of the national organization. It was once stated by a director of that organization that all of the Arbitration Committee's opinions were upheld unanimously except in one case where one dissenting voice was expressed. It might be stated that the early decisions of the committee still remain the foundation of a method of arbitration that is still giving the best satisfaction for adjudicating differences among members.

Mr. Gerstenberg was also formerly active in the work of the Crop Improvement Committee of the Council of Grain Exchanges and has been for years a familiar figure at all Western state grain dealers association meetings where his aid and counsel has been freely given and has contributed no small share in promoting the growth and the benefits of those organizations. It was a matter of appreciation that at the close of his services on the Arbitration Committee of the Grain Dealers National Association an embossed memorial testifying to his excellent work was tendered to him by a committee from the National body. Of this memorial which now hangs in the company's offices, Mr. Gerstenberg is justly proud.

Mr. Gerstenberg's duties as chairman of the Grain Committee of the Chicago Board of Trade at the present time brings him into close contact with the Federal agents of the Bureau of Markets, United States Department of Agriculture, and it is needless to say that a mutual esteem and confidence is enjoyed in this work. To see Mr. Gerstenberg on the Board, at his office, and at conventions of grain dealers such as the Des Moines meeting of the National organization at which our picture was taken is to have evidence presented that he

has an active mind, a sound physical body and years of usefulness ahead for himself and his patrons and friends.

POLITICS AND WHEAT

The whole country is pleading hopefully that the burden of taxation be reduced; and yet every day brings a new scheme to balk intelligent efforts in that direction. The latest to appropriate \$25,000,000 to stave off starvation in Germany hooked up with the scheme to dispose of a considerable portion of wheat stocks to help the wheat farmer, clearly is another maneuver for political support. The abundance of rye, much cheaper in price never enters into the calculations of these generous hypocrites.—*Pope & Eckhardt Company, Chicago, Ill., From late Market Letter.*

CORN AT INDIANAPOLIS

Futures showed some independent strength but cash markets generally were not disposed to follow the advance. Receipts are still light in all markets, inspections of all kinds today at Indianapolis being 75 cars, of which 9 were No. 3 or better, 13 were No. 4, 34 were No. 5, and 15 were No. 6 and 4 were sample corn. Shippers will note the predominance of No. 5 and No. 6 grades and will find it to their advantage to hurry the new corn in by tracing with railroad and to see that the papers arrive promptly in order that disposition may be quickly made. See that your way bill and bill of lading are marked "New corn; rush." We continue to believe in the wisdom of consignments.—*Bert A. Boyd Grain Company, Indianapolis, Ind. Market Letter of November 12.*

GROWTH OF VANCOUVER AS A PORT

Major W. G. Swan, engineer of the Vancouver Harbor Commission, prophesies that Vancouver will shortly rank as the second port on the Pacific Coast. In 1919 there was an average of four deep sea ships at one time at the docks. Today the average exceeded 10. The lumber industry has grown from 33,000,000 feet of sawn lumber to 300,000,000. In 1921 a total of 600,000,000 feet of logs came into the harbor, and last year there was 1,000,000,000 feet. Today the port is abreast of Portland and Seattle, and not far behind Los Angeles. By the season of 1924 the harbor would be ready to handle 70,000,000 bushels of grain. Approximately 3,000,000 bushels were shipped in September-October, and the November-December bookings are 10,628,000 bushels. Last year there were 7,000,000 bushels shipped to the end of December.

SOON ON NEW CROP BASIS

The readjustment from old to new crop basis is going on in our market at present and spot values therefore are quite unsettled as there is such a vast difference between the fine, dry, old corn and some of the poor wet, new crop that it is difficult to make any stable quotations from day to day. Receipts of new corn are increasing daily and it will not be long before the market will be entirely on a new crop basis when values can be quoted more intelligently. A great deal of the new corn which is arriving should never have been shipped or even shelled until it had cured out on the ear. This immature corn is arriving hot in many instances and is no doubt causing the shippers severe losses as the drying and shrinkage charges are large and after drying the corn is still of very poor quality.

Any corn which will grade 3 or 4 is meeting with an excellent demand and with stocks in the East as near exhaustion as they have ever been, there will continue to be a good demand until the trade have replenished their supplies and get a fair stock on hand. This will not occur, however, until the movement becomes large enough to cause a further downward adjustment in price and more stability in values is brought about.

Receipts of oats have been very light in this market for the past few weeks and with a slight improvement in the demand values are showing a tendency to creep gradually upward. There is no indication of any extraordinary demand for oats but with a comparatively small supply of stocks in elevators and no probability of much of an im-

provement from the farms for some weeks, we are likely to see a gradually hardening tendency in the oats market and spot prices are likely to work to a premium again.—*J. G. McKillen, Inc., Buffalo, N. Y. Market Letter of November 12.*

NO HEADWAY FOR WHEAT HOLDERS

Holders of wheat are making no headway. Meanwhile they are facing delivery on their contracts within a few weeks. In this respect it may be timely to point out that Chicago has 5,265,000 bushels of deliverable contract grades in public elevators, which compares with but 300,277 bushels last year at this time. There are over 13,000,000 bushels of wheat in private elevators, and while it is impossible to state the amount of contract grades, it seems that the percentage is large enough to prove burdensome. The Eugene Meyer report to the President condemns price fixing, an increased tariff and other things economically unsound. Like some banking reports it speaks of the improved condition of the farmer, suggesting diversified farming, recommending the cutting of our wheat acreage to a domestic basis.—*Rosenbaum Grain Corporation, Chicago, Ill. From Market Letter of November 9.*

GOOD DEMAND FOR CORN

The movement of corn is comparatively light thus far; practically all receipts now are of the new crop. The demand is very good, taking receipts at full prices and we can see no reason why this condition should not continue. We doubt seriously that there will be a movement for some time that will be greatly in excess of daily requirements. We, therefore, look for an increase in the price of the distant futures and that the price of cash corn will improve with the condition and quality of the corn.

There is only a moderate amount of wheat moving but the outlet is very limited. Our mills are well stocked, having bought heavily after harvest and we cannot see any great promise for an advance in wheat and we see no possibility of a large premium for Soft wheat, which we have usually had the advantage of later in the season. The fact that no wheat of the soft variety went out of the country after harvest, as it usually does, leaves a large proportion of the big visible stocks as well as a fair invisible stock in the Soft wheat sections to supply the needs of Soft wheat millers.

Oats are moving in moderate quantities and the higher grades are commanding good premiums. The general market is on about the same basis of other feeds and we can see no reason for any material decline in this grain.—*H. E. Kinney Grain Company, Indianapolis, Ind. Market Letter of November 12.*

BOARD WILL BRING SUIT

The Kansas City Board of Trade expects soon to file a suit for about \$1,000,000 in the Federal court against the railroads entering that market. The action, announced recently by W. R. Scott, transportation commissioner for the Board, will be for the purpose of recovering freight charges paid by members and country shippers in excess of the rate fixed by the Interstate Commerce Commission in an order made November 21, 1921, in which the railroads were directed to put into effect a lower rate on grain, grain products and hay, effective December 27, 1921.

The claims against the railroads will date from October 21, 1921, to January 7, 1922. A similar case was filed by the Omaha Board of Trade and the Federal court decided in favor of the Board. The railroads took an appeal and the case is now in the United States Circuit Court of Appeals.

The reduction order made by the Interstate Commerce Commission in 1921 was the result of a case originated by Clyde M. Reed, chairman of the Kansas Public Utilities Commission. The Kansas Commission contended the general increase of 35 per cent in freight rates allowed the railroads in 1920 was excessive so far as grain, grain products and hay were concerned. Middle western states joined the Commission in the request for a reduction.

October 20, 1921, the Interstate Commerce Commission found the 35 per cent increase of 1920 was twice as high on grain and hay as the Commission believed reasonable for the future. However, no

order was made for a reduction, and the railroads did not voluntarily make a reduction.

The Interstate Commerce Commission later issued a definite order, directing the railroads to reduce rates on hay and grain and put the new schedules into effect by December 27, 1921. Some of the railroads delayed the reduction until January 7, 1922. The suit of the Board of Trade, Mr. Scott stated, will contend that the shippers were entitled to the reduction from the time the Interstate Commerce Commission found the rate to be unreasonable "for the future" until the date the roads actually put the lower rates into effect.

The suit in all its phases is probably the largest of its kind on record, shippers familiar with such matters said. R. A. Jeanneret, chairman of the Board of Trade Transportation Committee, was appointed assignee for the plaintiff. The law firm of Morrison-Nugent-Wylder & Berger has been retained to represent the exchange. Grain men are of the opinion that they have established a strong case and are hopeful of the outcome.

The suit may involve a much larger sum than the grain shippers' claims make up. The Southwestern Millers League, the Kansas City Hay Dealers Association and many produce shippers have indicated that they may take similar action. The amount of their claims has not been estimated, but the total will be large.

RICE FUTURES

New Orleans has two future markets—cotton and sugar—and we take great pleasure in announcing the opening on November 5, 1923, of an additional future market, the New Orleans Rice Future Market. This will be the first rice future market in the United States and New Orleans will be its primary center. We hope to make it a very important factor in the commercial world—with its quotations serving as a guide to the rice interest throughout the world.

The liberal appropriation of the Rice Millers Association has made possible the establishment of this market. The rice interests of the South, ably assisted by experienced future traders from the New Orleans Cotton Exchange and the Louisiana Sugar & Rice Exchange, have during the past eight months carefully considered and solved the many intricate problems arising in the establishment of this market.

The rice future market will enable the rice grower to protect his interest against lower prices at harvest time by hedging his crop and will, in addition, improve his credit facilities. It must be thoroughly understood that when a farmer hedges his crop, it is done solely for the purpose of insuring a fair return, rather than for speculative purposes.

We repeat, that this feature which was not available in the past will solve some of the monetary problems that have confronted most of our rice growers and, on the other hand, the rice millers, wholesale grocers, dealers, and exporters will be enabled to protect their interests in the same manner by hedging in the future market.—*L. L. Jarreau, secretary, Louisiana Sugar & Rice Exchange, New Orleans, La.*

CORN AND HOG SITUATION

The corn and hog situation is very largely the reverse of what it was a year ago. A year ago old corn was abundant, and the new crop about average. Farmers then were going heavily into the hog business and wanted all the corn they could raise.

At the present time the supply of old corn is very small but the crop of new corn is larger than last year. The recent scarcity and high price of old corn has caused many farmers to slow down on the hog business. A year ago the price of corn was cheap as compared to the price of hogs. Now the price of corn is high as compared to hogs.

Although the total number of swine in the country is almost the same as a year ago, they are being marketed at an almost unprecedented rate. In recent weeks hog slaughter has been more than 25 per cent heavier than in same weeks a year ago.

Cattle also are being disposed of more freely than a year ago. The inference drawn from this situa-

tion is that the country demand for corn for feeding next spring and summer will be less keen than it was in the past year, and that the price relation between corn and hogs will narrow, that is, that the price of 100 pounds of hogs will pay for more corn, than in the past summer.—*Nat. C. Murray, statistician of Clement, Curtis & Co., Chicago, Ill. Special Market Letter of November 13.*

POLITICIANS NOT GOOD CROP EXPERTS

Wheat, at one time the cream of American soil, is finding a difficult path to follow. So much help has been suggested that buyers have utterly forgotten it. Figuratively speaking, a spoiled child becomes more unruly the more you sympathize with it, and perhaps this same condition prevails in the wheat market. A certain representative made a statement recently that we did not have any surplus wheat and also suggested that a guaranteed price should be established by the Government. If we are on a domestic basis why put a guaranteed price on wheat? It is such talk that brings forth unstable markets. The Government would do well to pass a few more laws to prevent politicians from acting in the form of crop experts. The trade were somewhat alarmed over the report that the United Kingdom may place an importation tax on wheat except from her dominions. We doubt very much whether the foreigner will close her doors to American grain, except where our price is higher. The condition abroad won't warrant it and therefore the report can be construed as a possible threat of retaliation to prevent our doing anything of a like nature.—*Updike Grain Company, Chicago, Ill. From Market Letter of November 9.*

THE SITUATION AT PITTSBURGH

Oats are inclined to be very much easier here at Pittsburgh and offerings freer at slightly lower levels. Buyers seem well taken care of and their requirements are small. Trade generally is pretty well booked ahead on oats and are carrying fairly good stocks. The quality of oats is averaging much better the past three weeks than it has prior to that time. Country offerings are increasing gradually.

The demand for corn has been principally for the dried and old grades. Ear corn has been arriving here and while the receipts have not been large accumulations have been noted and there is a total absence of demand. Stocks of corn are light and trade buying more or less for immediate shipment.

Offerings of wheat are very small, especially of desirable grades. Supplies are held very tightly and local mills are not securing sufficient quality wheat for milling. Farmers holding back selling. Transportation conditions are not what they should be and delays are quite common. Generally speaking the movement is gradually slowing down and with colder weather delays of serious nature are possible.—*Harper Grain Company, Pittsburgh, Pa., in letter of November 13.*

RECEIPTS LIGHT IN ST. LOUIS

The receipts of wheat to this market have been unusually light. Movement has been curtailed on account of farm work husking corn. We do not look for a material increase. The demand for Red wheat in this market has been fair for the best types but poor for the ordinary and lower grades. Flour demand is lacking and millers are only buying in small quantities. With the increase in the visible and the poor export demand it is somewhat remarkable that our cash prices held up as well as they have. We rather expect, between now and the first of December, lower values in wheat and then a good up turn at that time as Congress will meet in session on the 4th of December and the farm bloc will undoubtedly rush through a bill putting an additional duty on wheat from Canada.

Our corn market today was lower on account of large receipts but there was a good general demand and there will be from now on as stocks are low and we have had pretty sharp breaks. We have been unable to get any corn in the West up to the present time at satisfactory prices and firmly be-

lieve that our December corn here will sell considerably higher and it would not be safe under any circumstances to be short December corn in this market or Chicago.

The oat market is dragging along and holding up notwithstanding that receipts have been fair. There has been an unusually large amount of oats fed on the farms the past few months and some of these days the oat market will wake up and will have considerably higher prices.

It will pay the country shipper, however, better to ship his grain here on consignment than to sell on track bids which are under the market.—*McClelland Grain Company, St. Louis. Market Letter of November 13.*

CHANGES IN MEMBERSHIP

Chicago.—The following memberships on the Board of Trade have been transferred: Harry L. Gale, Jerome G. Steever, Estate of John E. Bellot, Samuel P. Wallingford, Fred F. Yule, Warren T. McCray, Gustavus B. Obey, Henry G. Campbell, Harry F. McCarthy, David J. O'Keefe, Jos. S. Tomenson and Henry B. Smith. Membership has been granted each of the following: Philip S. Arthur, Charles F. Scholer, Henry W. Cohn, Chester Reynolds Brautigam, John B. Clonan, Edward Bering Evans, Richard V. Nuttall, Frank E. Gulick, Wallace S. Howell, Joseph Leopold, Arthur J. Buston, Thomas E. Hosty. Thomas J. Bagley was reinstated to membership and C. A. Terrill and John W. McCardle were suspended. Reported by Secretary James J. Fones.

Cincinnati.—Frank Maguire has been elected to membership on the Cincinnati Grain & Hay Exchange. Reported by Executive-Secretary D. J. Schuh.

Duluth.—W. F. Converse, B. C. McCabe and C. E. Thayer are new members on the Board of Trade. J. L. McCaull, A. R. Rubey and R. P. Woodworth have withdrawn their memberships on the exchange. Reported by Secretary Charles F. MacDonald.

TERMINAL NOTES

The Hodgson-Davis Grain Company of Kansas City, Mo., has established an office in Springfield, Mo.

Arthur S. Dumont of Dumont, Roberts & Co. of Detroit, Mich., was recently elected to membership in the Chicago Board of Trade.

The office of McCardle-Black Grain Company of Indianapolis, Ind., for which a receiver was recently appointed, has been closed.

The Trans-Mississippi Grain Company of Omaha, Neb., has leased and will operate the Farmers Co-operative Elevator at Audubon, Iowa.

P. M. Clark, well known grain man of Hutchinson, Kan., has succeeded G. C. Hipple as general manager of the Security Elevator Company of that city.

A. L. Ernst of the Ernst-Davis Commission Company of Kansas City, Mo., has purchased the interest of Cort Addison in the Addison Grain Company.

Samuel Stanford, formerly connected with the Kansas City office of Armour Grain Company of Chicago, Ill., has become associated with Goffe & Carkener.

Ray S. Drake, formerly with the Gadsby Farmer Elevator Company of Gadsby, Sask., has formed a connection with James Richardson & Sons, Ltd. of Winnipeg, Man.

A. S. McVey, recently with the Bossemeyer Grain Company of Salina, Kan., has removed to Kansas City, Mo., where he is connected with the Kansas Flour Mills Company.

Logan & Bryan of New York and Chicago have opened a branch office in the New Biltmore Hotel, Los Angeles, Calif. Direct wire connections will be maintained to all principal markets of United States and Canada.

Nisbet Grammer, head of the Eastern Grain, Mill & Elevator Corporation of Buffalo, N. Y., and his associates have purchased the steamer *G. J. Grammer* from the Pioneer Steamship Company. The vessel is named for Mr. Grammer's father, the late

G. J. Grammer, and will be used in the lake grain trade exclusively. It will be operated from new offices which will be established in Cleveland, Ohio.

Charles W. Avery, former well known grain man on the Kansas City market, has gone to Buffalo, N. Y., where he is associated with the Great Lakes Grain Company.

The first car of new corn reached Baltimore, Md., October 29, and was shipped to G. A. Hax & Co. It graded sample grade on account of its 27 per cent moisture content.

H. C. Gamage of the Moore-Seaver Grain Company of Kansas City, Mo., was recently reappointed chairman of Arbitration Committee No. 5 of the Grain Dealers National Association.

Cort Addison, former head of the Addison Grain Company of Kansas City, Mo., has organized the Cort Addison Company to do a general grain receiving business in Kansas City.

Jule G. Smith, president and general manager of the Fort Worth Elevators Company, Fort Worth, Texas, has announced his candidacy for finance commissioner of the city of Fort Worth.

The many friends of Fred Jaeger, of J. F. Zahm & Co. of Toledo, Ohio, will be glad to learn of his return to the office after undergoing a successful surgical operation on his throat.

T. Murray Moynadier, grain merchant of Baltimore, Md., and vice-chairman of the grain committee of the Baltimore Chamber of Commerce, was recently elected president of the Society of the War of 1812.

Egil Steen has succeeded Thomas C. Craft, Jr., as chairman of the Executive Committee of the Baltimore Chamber of Commerce, Baltimore, Md. Mr. Craft resigned to engage in the stock and bond brokerage business.

William C. Engel, vice-president of J. H. Teasdale Commission Company of St. Louis, Mo., spent his annual vacation the latter part of October and first of November in Los Angeles and points in southern California.

E. C. Dreyer will represent the St. Louis Merchants Exchange of St. Louis, Mo., at the annual meeting of the Feed Control Officials of the United States, which will be held in Washington, D. C., November 22 and 23.

The first car of new corn to arrive on the Omaha market reached there October 19 from Carnarvon, Iowa, and was consigned to the Holmquist Elevator Company. It graded sample yellow and contained 27.4 per cent moisture.

The G. Clinton Adams Milling & Grain Company has removed from Winfield, Kan., to Kansas City, Mo., where it will continue business as the G. Clinton Adams Grain Company. Offices are at 265 Board of Trade Annex.

Peter P. McLaughlin, who has been connected with the grain trade of Chicago since 1880, took over the business of J. A. McLaughlin & Co., on November 1. The latter firm retired at the close of business October 31.

Edward H. Bagley, one of the prominent and popular brokers of the Chicago Board of Trade, Chicago, Ill., was recently presented with a large bouquet of flowers by fellow pit traders as a mark of esteem on his birthday.

The Postum Cereal Company has closed lease for the eighteenth and nineteenth floors of a new 20-story building to be erected on the block at Park avenue and Forty-sixth street, New York City. The building will be called the "Postum Building" and is expected to be ready for occupancy May 1, 1925.

E. H. Beer & Co., Inc., succeeded to the grain and hay business of Charles England & Co., Baltimore, on November 1. Mr. England has been for years one of the foremost grain and hay merchants on the Baltimore market. He has been prominent in the councils of the National Hay Association and has served as its president. He has also served the Grain Dealers National Association as president, director and in various other capacities. The good wishes of countless friends will go with him as he retires from active business. Mr. Beer, who succeeds to the business, has been

with the firm for years. He has been a regular attendant at western grain conventions where he is favorably known and in the East also is known as a broad gauge, energetic and competent grain and hay merchant.

The Canadian Grain Company, Ltd., Toronto, Ont., has been granted an Ontario charter authorizing it to do business as importers and exporters of grain and dealers in all kinds of farm produce. The authorized capital is \$100,000.

The Hallet & Carey Company, Ltd., and the Zenith Grain Company, Ltd., Winnipeg, Man., have been consolidated and will be known under the name of Hallet-Carey-Swart Company, Ltd. Harry Swart holds the office of president.

The Edward Jones Company of Minneapolis, Minn., an auxiliary of the Albert Dickinson Company of Chicago, Ill., amended its articles of incorporation effective November 1 changing its name to the Minnesota Commission Company.

Creditors of E. W. Wagner & Co., Chicago, who went into bankruptcy over a year ago, received checks for 10 per cent of their claims early in November. The distribution amounted to \$880,000 and makes a total of 60 per cent paid to date.

William M. Richardson, president of the Philadelphia Export Company and head of Richardson Bros., well known grain, feed and flour firm of Philadelphia, Pa., returned recently from Europe where he spent some months in the interests of his companies.

The Globe Elevator Company of Buffalo, N. Y., was recently awarded a contract for grain and feed to supply various state institutions, by the purchasing department of New York State, aggregating upwards of \$50,000. It was said to be the largest contract of its kind ever made by this department of the state's activities.

The Eastern Steamship Corporation of New York, has been incorporated with a capital stock of \$1,000,000 to operate and manage new boats re-

cently acquired. Directors are: Judge Lewis B. Hart, chairman; Nisbet Grammer, J. J. Rammacher, Edwin T. Douglass, Norman B. McPherson, W. P. Clement, George J. Grammer, John B. Richards.

The members of the St. Joseph Grain Exchange, St. Joseph, Mo., held a dinner and meeting at the Elks Club on the evening of October 30, at which good reports were read covering the activities of the third quarter of the year.

The Corn Products Refining Company, Chicago, recently declared an extra dividend of 75 cents a share on the common stock in addition to the quarterly dividend of \$1.50 a share. The quarterly dividend of \$1.75 a share was also declared on the preferred stock.

The Los Angeles Chamber of Commerce, Los Angeles, Calif., celebrated its thirty-fifth birthday with a dinner given by its membership on October 15. Frank Wiggins, who has been secretary of the Chamber for 34 years, received the congratulations of those present.

A new branch office has been opened at 502 Security National Bank Building, Sioux Falls, S. D., by the Eales-Prescott Company, grain merchants of Sioux City, Iowa. Charles E. Titterud, who has been in the grain business for 20 years, will be in charge of the office.

W. S. Hart, who has been treasurer and manager of the Flanley Grain Company at Omaha, Neb., for the past several years, has purchased the business and will continue it under the name of Hart-Grain Company. Mr. Hart is an experienced grain man and has a wide acquaintance in the western grain trade.

The Marshall Hall Grain Company of St. Louis, Mo., received the first car of new corn to arrive on that market. The corn was shipped from central Illinois in middle October and graded sample grade, containing 28 per cent of moisture. It contained only three per cent of damaged grain, and sold at 85 cents.

TRADE NOTES

S. T. Scofield, recently advertising manager and division sales manager of Kilbourne, Jacobs & Co., Columbus, Ohio, is now advertising manager of Fairbanks, Morse & Co. of Chicago, succeeding C. M. Briggs, who has been transferred to the purchasing department.

Discriminating grain dealers who sell side lines to the farming trade are handling the Ankorite Studded "T" Post manufactured by the Calumet Steel Company of Chicago, Ill. They have many points of excellence which are set forth in an attractively printed folder which will be mailed to any address on request.

Sales of the Wonder Grain Cleaners, manufactured by the Weller Manufacturing Company of Chicago, Ill., have been exceedingly good during the past few months. Orders have been coming in from all parts of the country from grain elevators and mills, among the former both co-operatives, line and independent houses.

J. A. Peterson, superintendent of the Western Maryland Elevator at Baltimore, Md., was recently notified by his patent attorney in Washington that his application for a United States patent on the Peterson Pneumatic Grain Door Remover had been allowed. The Strong-Scott Manufacturing Company of Minneapolis, Minn., is selling agent for the door.

The Peabody Coal Company, with main office at 332 S. Michigan avenue, Chicago, Ill., maintains branch sales offices at Cincinnati, St. Louis, Springfield, Ill., Kansas City, Omaha, Deadwood, S. D., Kleenburn, Wyo., Spokane, Wash. The company has recently issued a very handsome book covering their mining operations, giving the number of the mines, location, railroad, shipping point, trade name

and daily capacity. The total daily capacity is 86,700 tons, with annual capacity of 26,010,000 tons. There is also given some very interesting information about the Peabody Coal Company and the processes of mining coal.

The Clements Manufacturing Company of 610 Fulton street, Chicago, Ill., manufactures a very useful device for ridding the elevator property of explosive dust which has a tendency to light on every ledge and projection in the building. It consists of the Cadillac Portable Electric Blower for hand use. No dangerous explosions causing loss and life and property where this machine is part of the elevator equipment. A penny postal will bring an illustrated folder giving prices, particulars, etc.

BLACK CHAFF

Black Chaff, a bacterial disease, made its appearance this year for the first time in epidemic form in the wheat fields of North Dakota. Many wheat fields were badly damaged. Marquis wheat as well as Kota appeared to be very susceptible to the disease, and the same was true of Kubanka and other Durums. Specimens of diseased plants were secured from about a dozen different counties and it is believed that black chaff occurred in practically every county in the state.

Black Chaff shows itself by discolorations and stripes on the stems, leaves and glumes which cover the kernels in the head, the color of the markings ranging from yellow to chocolate brown and black, the last being the most common. The superficial observer easily confuses black chaff with black stem rust, and the two diseases have much the same effect in dwarfing the heads and

producing shriveled, light-weight kernels. The disease is believed to be carried over in seed from year to year.

Black Chaff was first found in epidemic form in Kansas in 1915. In 1918, heavy losses were caused in South Dakota and Montana, in some cases as much as 50 per cent. While black chaff has been found in North Dakota wheat fields in former years, this year is the first time it has been epidemic.

A POPULAR TRAVELER

J. M. Bell, who for the past five years has represented the Bauer Bros. Company of Springfield, Ohio, with offices at Springfield, Ohio, has recently been put in charge of their Toledo sales office. "Joe," as he is familiarly known to the elevator and milling trade throughout the states of Ohio, Michigan and Indiana, has a large following of friends who will be pleased to learn of the promotion.

Mr. Bell is one of the younger generation of feed milling engineers, a graduate of the school of experience and hard knocks, and enjoys a reputation of having been instrumental in bringing into



JOSEPH M. BELL

use a great many of the modern features now in use in feed milling establishments. He is in a position to give estimates or appraisals and is always glad to furnish any data or information regarding the building, equipment or operating of feed mills.

As the accompanying picture clearly indicates, Mr. Bell is a young man, his birthplace being Cleveland, Ohio, and the date March 19, 1888. He passed his boyhood on a farm in southern New York and returned to Ohio some 15 years ago, settling at Springfield. He traveled for two different commercial houses before going with Bauer Bros. Company in 1919 and is now representing this old established machinery firm in Ohio, Michigan and Indiana.

WINTER WHEAT IN SOUTH DAKOTA

Reports have taken cognizance of Winter wheat in South Dakota for 10 years. The acreage was at its highest in 1916, when it was 150,000 acres and the yield 2,775,000 bushels. By 1921 the acreage shrunk to 75,000 and the production to 1,050,000 bushels. While this seems a heavy decrease, nevertheless while Winter wheat declined 47.7 per cent from the highest production, Spring wheat declined 63.2 per cent.

The average yield of Winter wheat in South Dakota for 10 years was 13.45 bushels per acre. The average yield of Spring wheat in the same 10 years was 10.03 bushels per acre. The highest average yield of Winter wheat was 20.5 bushels and of Spring wheat, 17 bushels, both in 1915. The lowest yield of Winter wheat was 9 bushels in

1913 and of Spring wheat, 6.3 bushels in 1916. In that year Winter wheat averaged 18.5 bushels. The Winter wheat region of South Dakota lies south of a diagonal line drawn from Grant to Custer Counties. But it is most successful south of a line through Brookings and Huron.

SOME CORN HISTORY

According to bulletins sent out by the Montana experiment station, a study of corn growing by the Indians in the northern portion of the country and in southern Canada shows that the crop has long been cultivated and was one of the chief sources of food supply many years ago. All authorities are agreed that corn is of hybrid origin and a native of some part of Mexico. It is probable that in comparison with wheat, this crop is of somewhat recent origin, and therefore not as fixed of character as crops that have been longer established. Few crops show adaptability to so wide a range of conditions as corn. Some varieties mature in 80 days and some require 200 days. With this adaptability it is reasonable to assume that the limits of possible corn culture are as yet unknown.

During the pre-Columbian period in North America, corn was widely disseminated. Representatives of the bureau of American Ethnology have concluded that corn was cultivated by practically all of the Indian tribes of the forest region east of the plains area, northward to the limit of successful cultivation somewhat beyond the line of the Great Lakes and St. Lawrence. It was probably not cultivated on the plains except by the Hidatsa, the Arikara and Mandan tribes in North Dakota and the Pawnee and Omaha tribes in Nebraska. It was cultivated also by all of the Pueblo, the Navajo and all the other tribes in the southwest.

Proof has also been presented that dissemination took place many centuries ago and that corn is found in most of the archaeological remains in the northern part of the United States. Since the Indians were the first dry-land farmers and corn raisers of the northwest, Montana corn history naturally begins with them. Their product was the last of the Indian corn to be adopted by the white man, and since the early flint group is directly derived from it, the methods of culture and history are of much interest and importance.

There is no evidence to prove that the original Montana Indian tribes raised corn for food. While the Crows are a branch of the Hidatsa, who were corn growers, they must have dropped their corn culture as a source of food when they migrated to the upper Yellowstone. Their traditions would not indicate that any considerable thought was given to corn growing during their life in this state. However, there is evidence that this tribe raised it in a ceremonial way. Peter Koch of Bozeman acted as post-trader at the "new Crow Agency" located on Rosebud Creek just above the confluence of Stillwater Creek, in the spring of 1876. He stated several years ago that he witnessed a corn dance of that tribe and that he tried to secure some of their seed.

He was not successful and was not even permitted to see their corn. The seed was regarded by the Indians as sacred, and they kept the place where it was planted hidden.

Duncan McDonald, a member of the Flathead tribe, undoubtedly one of the best authorities on their social and economic life, furnished the Montana State College at Bozeman with data, which proved that originally the Flatheads did not raise corn, but that between 50 and 100 years ago, the traders introduced it and corn has ever since been grown only in a small way, but was regarded as one of their most delicious vegetables. They gained considerable knowledge of corn from the Iroquois Indians, who came with the traders as guides and helpers.

The first cornfield of any size in Montana, of which there is any authentic record, was planted near Forsyth in the Yellowstone Valley in 1879. It was called "squaw corn" and was planted in sod. It had a very short growth, about 4½ feet in height, would yield about 35 bushels to the acre and was considered the surest crop that could be grown at

that time. That was the only corn grown until after the advent of the Northern Pacific Railroad in 1882, and from that time on different kinds of corn were brought in from different states.

Very fine corn, yellow dent, was planted in that same district in 1885, and averaged 40 bushels to the acre. All this corn was grown on non-irrigated land. The early stock rancher in Montana was not a farmer, and aside from a small patch for chicken feed, very little corn was grown until the advent of the dry farmer.

According to Government statistics, there are in Montana 18,000,000 acres of land adapted to the production in the rotation of crops of some type of corn. This area is equal to three-fourths of the combined corn acreage of Iowa and Illinois.

Corn has made the most rapid proportional increase of all the important crops. With 1,600 acres in 1900, the following 22 years brought an expansion of the state's acreage up to 219,000 acres in 1922, and while the reports for 1923 are not yet available, it is stated by authorities that at least 8,000,000 bushels of corn were raised this year.

RUSSIAN AGRICULTURE

Russia as an exporter shows signs of awakening from her dormant state. A country, which before the war exported large quantities of grain, oil cake,

ACREAGE OF CROPS IN RUSSIA, 1909-13.

Crop	Russia in Europe	Ex-Russian terri-	European Russia	Asiatic Russia	All Russia includ-
	Old boundaries	tory now included in other countries	including Ukraine, present territory		ing Ukraine, present territory
	1,000	1,000	1,000	1,000	1,000
	Acres	Acres	Acres	Acres	Acres
Wheat ...	61,456	3,708	57,748	16,789	74,537
Rye	70,384	10,987	59,397	3,309	62,706
Barley ...	28,060	4,623	23,437	2,912	26,349
Oats	42,063	6,116	35,947	5,742	41,689
Millet	7,428	142	7,286	1,545	8,831
Buckwh't ..	5,129	569	4,560	269	4,829
Corn	3,923	1,892	2,031	1,215	3,246
Potatoes ..	11,004	4,075	6,929	445	7,374

PRODUCTION OF CROPS IN RUSSIA, 1909-13.

Crop	Russia in Europe	Ex-Russian terri-	European Russia	Asiatic Russia	All Russia includ-
	Old boundaries	tory now included in other countries	including Ukraine, present territory		ing Ukraine, present territory
	1,000	1,000	1,000	1,000	1,000
	Bushels	Bushels	Bushels	Bushels	Bushels
Wheat ...	663,897	54,819	609,078	151,113	760,191
Rye	921,913	206,647	715,266	32,679	747,945
Barley ...	467,793	84,345	383,448	36,795	420,243
Oats	981,138	155,150	825,988	107,574	933,562
Millet	89,191	2,406	86,785	13,365	100,150
Buckwh't ..	52,915	6,361	46,554	2,113	48,667
Corn	70,222	33,830	36,392	15,793	52,185
Potatoes ..	1,252,377	531,158	721,219	35,296	756,515

lumber and other agricultural products suddenly dropped from sight, and other excess producing countries were called upon to supply the deficit. In doing so the United States, Canada, Argentina, and Australia expanded the acreages sown to bread grains. In the United States the acreage has receded somewhat from the peak but Canada and Argentina seem to be still increasing.

In this situation Russia shows marked tendencies toward returning to its pre-war position as an exporter. It is true that only small quantities of grains have yet been exported but the machinery for handling this trade is being gradually built up. Trade agreements have been entered into between the Soviet government and importers in Germany, Austria, Denmark, England and Norway which establish the trade connection, fix the method of payment, and otherwise render intercourse more easy. However, the most significant fact pointing to Russian recovery is an increase of from 15 to 20 per cent in the acreage sown to crops this season. This is the general increase throughout the Federated Soviet Republics, including Ukraine, while in the famine regions the increase is in some instances as high as 30 to 35 per cent, according to figures which have reached the Department of Agriculture from several sources.

The weather conditions affecting the present crop

have not been as good as last year and hence the Soviet government estimates an average yield per acre somewhat less than that of 1922. In fact the total production is expected to be about the same as last year though no data have yet been received to indicate the production of the various crops.

About 46,000,000 acres of rye was sown in Russia and Ukraine in 1922, according to the Central Bureau of Statistics at Moscow. The pre-war average acreage for the same territory as nearly as it is possible to determine was about 63,000,000 acres. The 1922 acreage of wheat was about 22,400,000 acres compared with 74,500,000 acres pre-war.

The above figures indicate that Russia is still far short of the pre-war acreage but the announcement of a 20 per cent increase in acreage this year is a distinct step towards pre-war conditions. It may be noted that rye has more nearly approached the pre-war acreage. This has been explained by the fact that most of the wheat was grown on large estates and since these have been broken up among the peasants there has been an increase in rye acreage at the expense of wheat.

For the purpose of comparing recent agricultural statistics of Russian territory with pre-war estimates for the same area, there is given in the following table a calculation of the average acreage and production of crops during the years 1909-13. These estimates are based upon the best information available for the present boundaries of Russia, including Ukraine and for the several governments or parts of governments now included in other countries. The territory excluded from former European Russia comprises Congress Poland and the governments of Bessarabia, Esthonia, Livonia, Courland, Kovno, Grodno, Vilno and parts of Vitgbsk, Minsk and Volhynia, which are now distributed among the republics of Esthonia, Latvia, Lithuania, Rumania and Poland.

These calculations purport to be nothing more than rough preliminary estimates subject to revision as the division of production by changes in boundary lines become more accurately determined.

RUSSIAN TRADE AGREEMENTS

The twelfth Congress of Russian Communists convening at Moscow in March, 1923, decided upon an extensive export program for Russian grain during 1923 in an attempt to provide the country with foreign farm machinery and other equipment necessary to rehabilitate agriculture.

The first development in carrying out the grain export scheme, was an agreement entered into with the National Grain Office of Germany, "Reichsgetreidestelle," by which the Soviet government undertook to deliver 330,000 tons of grain to Germany at world market prices by the end of November. Under the terms of the agreement Germany contracted to advance to the Soviet government 50 per cent of the value of the entire stipulated quantity of grain, this money to be applied to purchases by the Soviet government in Germany. No foreign exchange whatever is to enter into the transaction. To assist in moving the grain the Baltic National Shipping Company, a concern operated by the Soviet government, purchased and chartered a number of steamers from German owners. In addition available railway cars in both European Russia and in Siberia have been assembled for the transportation of grain to the Baltic and Black Sea ports.

In Norway the Russian Trade Commissioner has made a similar agreement. The recent purchase of 10,000 tons of rye from Russia by the Norwegian Foodstuffs committee brings the total Norwegian purchase of Russian grain this year up to 25,000 tons. Negotiations are now being considered for the purchase of grain in the Black Sea ports.

An Austro-Russian Trading Company known as the "Rusawstorg" has also been organized with a capital of \$1,000,000 in shares of \$1,000 each to be divided equally between the Soviet government and a syndicate of firms in Austria. The purpose of this trading company is to supply the Austrian market with Russian raw materials and in turn to export Austrian manufactured articles to Russia.

A further instance of the Soviet's program for

grain exports is the recent lease for a period of 12 years of a large elevator in Reval Esthonia which was built by the Russian government about 25 years ago. The annual rental of the elevator has been fixed at 12,000,000 Esthonia marks. The elevator is to be repaired and placed in order within six months. It will be used for the storage of grain exported from Russia via Esthonia.

Another development is the recent establishment of an office of the Russian corporation "Eksport-khleib" at Copenhagen, Denmark, which commenced its activities in August, 1923. According to the Foreign Office Bulletin, Copenhagen, for September 13, the "Eksportkhleib" was organized for the purpose of exporting oilseeds, oil cakes, vegetable oils and other foodstuffs from Russia to and via Denmark. Its organizers were the "Vneshtorg" (People's Commissariat of Foreign Trade), "Gosbank" (the Soviet State Bank), the "Centrosoyuz" (All Russian Central Union of Consumers Societies), "Khlebprodukt" (The Russian Grain Collection Organization), "Selskosoyuz" (All Russian Agricultural Union), and "Vsekobank" (the All-Russian Co-operative Bank). This corporation will undertake the warehousing, transportation and insuring of its product, both within the borders of Russia as well as abroad. It will also handle the same products in a like manner on a commission basis for Russian exporters. It is stated that the company has established branches in Petrograd, in most of the Black Sea ports and in Hamburg, Riga, Rival, Berlin and London.

A movement to establish trading in wheat between Russia and the United Kingdom is the latest development in the Soviet grain exporting scheme. The parties interested in the scheme are the Soviet government, two English wheat importers and the British Co-operative Wholesale Society. The Manchester Guardian for October 6, states that these parties have agreed to the formation of the Anglo-Russian Wheat Exporting Company, capitalized at approximately \$500,000. According to the articles of agreement, payment for all shipments received from Russia will be made at once from the accumulated capital, none of which will leave Great Britain except for direct settlement of accounts rendered for wheat.

According to the London *Times*, Russia and England have entered into business relations quite definitely so far as the trade in grain is concerned. The Russian Trade Delegation in London states that an agreement has been signed for the formation of a Russo-British grain export company, composed of 50 per cent British and 50 per cent Russian interests.

The Russian side is composed of representatives of Government and co-operative organizations concerned in the export of grain, namely: Exportkleb (State Grain Export Company), Centrosoyuz (Russian Co-operative Union), and Arcos (Russian Buying and Selling Agency in England).

The British side is constituted of (1) The Co-operative Wholesale Society; (2) two leading firms of grain brokers, namely, Shipton, Anderson & Co., and A. E. Lawrence & Co., and in addition, Furness, Withy & Co., shipowners and shipping agents.

The board of the company will consist of four Russian and four British representatives. The object of the company is to finance grain in Russian port warehouses and afloat and to market it in Great Britain, France, Italy and Southern European countries. Leading British banks are prepared to give credit at any time up to £1,000,000. The company will begin operations immediately.

ARGENTINE GRAIN CROPS

Argentine wheat production this year is forecast at 248,752,000 bushels as compared with 189,046,000 bushels last year, according to a cable received by the United States Department of Agriculture from the International Institute at Rome. Average production during the 1909-13 period was 157,347,000. The rye crop is forecast at 3,701,000 bushels compared with 2,147,000 bushels last year, barley at 4,593,000 bushels as compared with 7,656,000 bushels, and oats at 58,560,000 bushels compared with 54,975,000 bushels last year.

TRANSPORTATION INSTITUTE MEETS

A joint meeting of the directors and research council of the National Transportation Institute was held in New York November 7. Bird M. Robinson resigned as treasurer. The resignation was accepted with a vote of thanks for his service and appreciation of his work in creating the institute and getting it started in its work. He is succeeded as treasurer by Ralph Van Vechten, vice-president, Continental and Commercial National Bank, Chicago. Mr. Robinson is still chairman of the Executive Committee. Several new members of the research council and of the board were elected, subject to their acceptance. Mark T. McGee, in charge of organization work, and Capt. Gorby, in charge of the department of public relations, were made vice-presidents.

Chairman Edgar E. Clark and Dr. David Friday, director, of the research council, were present and made an extensive report on the work under way, some of the results of which will be ready for public announcement soon. The research council acts independently of the board as to what investigations it shall pursue and has charge of its own expenditures, subject to the budget allowed by the board. It makes its reports, however, to the board and the board looks after the matter of making them public.

There was a full discussion by the board of organization and educational work.

Something of the origin of the Institute was related by Mr. Robinson in his report:

The question is constantly being asked: Who originated the Institute; who organized it; who paid for it, and what was the cost?

The imperative need for an authentic, impartial and reliable source of information about transportation in its broad aspects, especially those most immediately affecting the public, was impressed upon my mind prior to the beginning of the World War. The events of the war period, and of the years immediately following, convinced me that the public was being misled about its transportation agencies, in some respects gravely misled. Upon thorough investigation, I became convinced that there was no recognized source of impartial information about transportation in all of its aspects and bearings, to which the public could look or would accept. I was forced to the conclusion, which seemed to be almost universal, that practically all of the research work, with reference to transportation, was being done from some partisan point of view, hence that, regardless of the facts ascertained, no matter how sound, they were either discredited or rejected by a large part of the public.

I was impressed with the demonstrated fact that the absence of an impartial and authentic ascertainment of facts afforded the radicals and the unscrupulous politicians a free field in which to mislead the public, and that they were utilizing the opportunity to the fullest extent.

I became convinced that the key to the whole problem, the one thing necessary above all others, was the ascertainment of the real facts, all of the facts, and the intelligent interpretation thereof, in a way not only to justify but to demand the full confidence and respect of all fair-minded and honest citizens.

To accomplish that all-important object, I recognized that two things were necessary; first, that there must be a fact-finding and interpreting body composed of the ablest, most upright, most impartial and best known men in the country, men of the broadest experience, not only in transportation, but as to general business affairs; and second, that the body thus composed must be made absolutely independent of any control, financial or otherwise, in other words must be given exclusive jurisdiction over all investigation work, and be held responsible for the good faith of the results.

Following the key problem, the next in importance was to devise feasible, workable plans to convey the facts ascertained, in a way that every person could understand, plans that were commensurate with the magnitude of the problem, and through such plans and efforts, to aid in educating the public to know that its interests are inseparably linked with its transportation agencies.

With the assistance of Hon. Sydney Anderson, Mr. James R. Howard, then president of the American Farm Bureau Federation, and others, I gave a dinner in Chicago, Ill., on December 8, 1922, at which the subject of the organization was submitted and endorsed, and a representative committee was appointed to aid in arousing interest, and to participate in arranging for an organization.

With the assistance of Messrs. Anderson, Howard and Hon. Edgar E. Clark, and others, especially with the assistance of the president and secretary of the Chamber of Commerce of New York, I gave a dinner in New York on January 18, 1923, at which the subject of the organization was submitted with full information as to the action taken at Chicago. The participants then

endorsed the proposed organization, and the steps there taken, and named additional members of the committee appointed at Chicago.

The committee appointed at Chicago and New York met twice, one in each of said cities. After careful consideration, that committee approved, in a general way, the by-laws to be adopted, and decided that the institute should be organized under the laws of Illinois. It then appointed an organization committee and instructed it to proceed, with the knowledge and understanding that the members of that committee would become directors.

The members of the organization committee discharged their duty by organizing the National Transportation Institute on April 16, 1923, and by the adoption of by-laws and the election of officers.

Early in 1922, while I was engaged in the preliminary work, it became necessary to ascertain what outstanding men would agree to become the responsible officials. Believing that the impartial fact-finding body was the most important, I presented the proposition to Hon. Edgar E. Clark. I regarded him as pre-eminently fitted for the head of that all-important work. After consideration, Mr. Clark advised that he would accept the chairmanship of the body created for that part of the work, upon condition that the institute would be organized and conducted in an impartial and really representative basis.

In due time I became impressed that Hon. Sydney Anderson was especially fitted to participate actively in the work of the fact-finding body, and I invited him to become vice-chairman with Mr. Clark. He accepted the invitation, subject to the same conditions named by Mr. Clark, as to the impartial and really representative basis of the organization.

I regarded the selection of a president as a matter of the greatest importance. After considering many outstanding individuals, I decided that Mr. James R. Howard was, upon the whole, the most desirable man, and I then invited him to accept that responsible position. Mr. Howard was strongly in favor of the proposed organization. He had participated in having it endorsed by the National Agricultural Conference, of which he was a member. He had also aided in having the proposition submitted to the Joint Commission of Agricultural Inquiry of Congress, with which he was connected. Mr. Howard had my appeal under consideration for several weeks, during which time I saw him frequently. When he finally decided to join in the work he insisted that I should become the president and he would become the vice-president. I declined to agree to that arrangement, and he thereupon agreed to accept the presidency.

When I decided about the first of August, 1922, to create the institute, I was confronted with the necessity of obtaining funds with which to pay necessary expenses. I promptly determined not to ask for financial assistance from any one or concern that had any reason to hope or expect to ever control in any way. I wrote a number of personal friends, most of whom were connected with short line railroads, and asked them to subscribe funds for preliminary organization expenses, suggesting a minimum of \$25 and a maximum of \$1,000.

During the period, August 8, 1922, to April 9, 1923, 41 of my friends subscribed and paid me, from time to time, \$6,950, all of which was promptly deposited in the American National Bank in Washington, D. C., to the credit of the National Transportation Institute. A full and accurate record of all subscriptions was made, and that record is available to all concerned.

The funds were disbursed by checks and proper receipts were taken, all of which have been preserved.

The funds were used in the payment of expenses of all kinds, including the cost of the large public dinners and luncheons, traveling expenses, printing, postage and other office expenses, and \$2,167.50 compensation paid Hon. Sydney Anderson for service after January 1, 1922, which I felt justified in paying and which he was justified in receiving.

The balance on hand on February 1 was not sufficient to meet the obligations, and I then advanced \$1,650. Subsequently and prior to April 16 the balance of the subscriptions from my friends were received, and \$1,000 of the amount advanced by me was repaid, leaving \$650 unpaid. That amount was paid in full after April 16.

GLUTEN IN THIS YEAR'S SPRING WHEAT

Tests made indicate that the gluten content of Hard Spring wheat of this year's crop is high. Last year it is said that Hard wheat in the Red River Valley averaged about 12 per cent gluten. The Russell-Miller Milling Company recently made 14 tests in its Minneapolis laboratory of wheat from the same region and found the gluten content ranged from 12 to 14.3 per cent.

The agronomists of the State Agricultural College of North Dakota at Fargo made 5 tests from wheat grown in the county and found a range of dry gluten from 12.16 to 14.96 per cent. This year an effort is being made by the North Dakota Agricultural College to have gluten tests made from representative sections of each county. One reason for this is that weather conditions are

largely responsible for the relative gluten content and these, of course, may vary widely even in a fairly limited space. The present year, unfavorable for wheat in Dakota in many respects, was so far as weather was concerned, rather favorable to a high protein content in the grain.

NON-FREEZING MIXTURE FOR FIRE BARRELS

This is the time of the year when elevator's fire barrels should be prepared for winter duty. The best non-freezing mixture for this purpose is calcium chloride (commercial 75 per cent), mixed according to the temperature as given in the following table:

In climates where the temperature does not go below:	Pounds of Calcium Chloride for each gallon of solution
18 degrees above zero.....	2 lbs.
Zero	3 lbs.
10 degrees below zero.....	3½ lbs.
18 degrees below zero.....	4 lbs.
40 degrees below zero.....	5 lbs.
60 degrees below zero.....	6 lbs.

The calcium chloride is preferable to common salt, as the latter gets foul smelling after a time and is injurious to the hoops on the barrels or to iron tanks.

Fix up your solution before the first hard freeze-up comes. It is at just such a time, when your barrels may be frozen solid, that your fire hazard may be greatest. Ever notice the numerous fires that accompany the first cold snap?

POLISH AND POULARD WHEATS SPECTACULAR BUT OF NO COMMERCIAL VALUE IN U. S.

Man craves spectacular things even in a commonplace crop, such as wheat. Polish and poulard wheats are among our most spectacular cereal crops in appearance, and the stories which have accompanied the exploitation of these two grains would excite the interest of the most indifferent farmer. Neither of these wheats is of commercial value in America, says the United States Department of Agriculture, but both have been offered many times and are still being offered to the buying public by unscrupulous or unknowing promoters who take advantage of their striking appearance.

Farmers' Bulletin 1340, Polish and Poulard Wheats, has just been published by the United States Department of Agriculture to answer the frequent requests for information concerning the origin, productivity, and value of the varieties of Polish and poulard wheats grown in this country and to warn farmers against paying high prices for seed of these nearly worthless grains.

Polish wheat has large heads, frequently six or seven inches in length and an inch or more in diameter. The kernels are long, sometimes half an inch in length, and are very hard. The one variety of Polish wheat grown in this country, White Polish, somewhat resembles rye and has sometimes been wrongly sold as a variety of "giant" rye. It can be grown only in the Spring wheat region, and there it seldom yields more than half or two-thirds as much as other varieties. It is not used in the manufacture of bread-making flours or semolina products, such as macaroni and spaghetti.

Four varieties of poulard wheat have been grown in the United States in recent years, three of which have branched or composite heads. The Alaska is the best known and most widely exploited variety. It yields lower than other commonly grown varieties and is unsuitable for making flour. The history, adaptation, and description of the varieties of Polish and poulard wheat are given in this bulletin, a copy of which may be obtained, as long as the supply lasts, from the United States Department of Agriculture, Washington, D. C.

STOCK feeders in Indiana claim that, where old corn took eight to 10 bushels to make 100 pounds of fat, it is going to take from 14 to 16 bushels of the new chaffy corn.

ECONOMIC ASPECTS OF THE PROBLEM OF RESTORING THE PURCHASING POWER OF AMERICAN FARMERS*

BY DAVID FRIDAY

Professor of Economics at the New School for Social Research, New York City; former President of the Michigan Agricultural College

The farmers of this country are disgruntled and exasperated to the point of political revolt. The cause for their state of mind is a lack of balance between the prices they get for their products and those they pay for the things they buy. The Department of Agriculture tells us that "the purchasing power of farm products today is only 72 per cent of what it was in 1913." In 1921, it had fallen as low as 67 per cent.

Just how this has affected the farmer's economic position and the balance of industry in this country is forcibly shown by figures which have recently been made public for manufacturing industries in the year 1921. During the 20 years from 1899 to 1919, the value added by manufacturers to the materials with which they worked had increased from \$4,831,000,000 to \$25,042,000,000. During the same period the gross value of all agricultural products had increased from \$4,717,000,000 to \$23,783,000,000. During these two decades the growth of reward for the productive services rendered by the two industries had been approximately at the same rate. Manufactures had slightly outrun agriculture, but the Federal Government "rectified" this matter by taking from the manufacturing corporations \$1,359,000,000 in income and excess profits taxes, thus leaving the manufacturers almost exactly the same relative increase which the farmers had enjoyed.

When the figures for the census of 1921 were made public a few weeks ago, they disclosed the extent to which this balance between agriculture and manufactures had been destroyed. The value added by manufactures in that year amounted to \$18,315,000,000; while the gross value of farm products for the same year had been given by the Department of Agriculture at \$12,366,000,000. The balance which had existed for the first two decades of this century was first seriously disturbed in 1920, and it will certainly not be restored during the year 1923. Such evidence as is available at this time indicates that the value added by manufactures will be not less than \$23,000,000,000; while the gross value of agricultural products will not be far from \$15,500,000,000.

The striking nature of the correspondence between the figures for manufactures and for farm products during the two decades from 1899 to 1919, and their divergence during the last four years, will become more apparent if we set them down in a compact table. The figures for agriculture are available each year, and are compiled by the Department; the census of manufactures was taken only once in five years up to the year 1919. Beginning with 1921, however, it is to be taken every other year. The figures for 1921 are therefore actual, while those for 1920, 1922 and 1923 have been estimated from the data at hand concerning profits, wages and prices.

Year	Value Added by Manufactures	Gross Value of Farm Products
1899	\$ 4,831,000,000	\$ 4,717,000,000
1904	6,294,000,000	6,122,000,000
1909	8,529,000,000	8,558,000,000
1914	9,878,000,000	9,895,000,000
1919	25,042,000,000	23,783,000,000
1920	27,000,000,000	18,263,000,000
1921	18,315,000,000	12,366,000,000
1922	20,500,000,000*	14,310,000,000
1923	23,000,000,000	15,500,000,000*

*Estimated.

The great mass of the American people would like to see the farmer's condition improved. If the purchasing power of his products could be restored to its pre-war position, it would satisfy practically all classes. For it can be said in all honesty that we Americans have a generous sympathy with those who till the soil. Many of us are the first of our

*Reprinted from the October, 1923, issue of *Trade Winds*, the monthly publication of the Union Trust Company, Cleveland, Ohio.

line to have left the farm, while others are producing things which are sold chiefly to the agricultural community.

We are in accord as to the end which is to be attained. But on the means of attaining it and the methods to be employed, we are by no means clear. Shall the balance be restored by raising the prices of farm products or by reducing those of manufactures and other industries? The former is more to the taste of the American people. It makes it easier to pay debts, and many of the debts now in existence were contracted during a period of high prices. This is especially true of the farmers' obligations. Then, too, the generation of business men bred up during the period of increasing prices which prevailed from 1896 to 1920 look upon a gradually rising level of prices as a normal condition of affairs and are naturally averse to seeing the balance restored by any further downward movement.

How shall this increase in agricultural prices be brought about? There are still a few who would like to accomplish it by tinkering with the monetary system. But after the recent European experience—to say nothing of our own recent credit inflation and our experience of the nineties—we are pretty well immune to schemes of monetary reform. Price stabilization through Government guarantees to the farmer is the remedy which provokes the greatest enthusiasm and commands the substantial following which makes the agricultural movement a formidable political one. But as a people we shrink from Government price guarantees, because we are exceedingly dubious about giving doles to any class. We still have a hard-headed Anglo-Saxon faith in the ability of the natural workings of competition and the movement of capital and labor from one industry to another to set things right. Many of us, too, have the gravest doubts whether the Government, even with the best of intentions, can effect any material change in the price situation which will hold for the long run, unless conditions of supply and demand are such that they would automatically raise the price.

In this situation it is worth while inquiring what effect the automatic working of economic forces has had upon agricultural prices in the past. The utterances of some of the spokesmen for agriculture in the last two years would lead us to believe that the existing disparity between agriculture and other prices is a chronic condition. As one farm bloc Senator put it recently: "The farmer never has had a square deal. The prices he must pay and the prices he gets are fixed by the middleman. The one thing which has saved him has been the fact that he got his land from the Government for \$1.25 an acre and that land has advanced in price from a low value. Now the advance in price of land has ended. The price is backward."

It is not reported whether any scoffing bystander asked the Senator whether the lands of Iowa rose from \$1.25 per acre to \$300 because of some secret property of levitation which inheres in land prices; or whether the prices of the products which this land produced had risen so amazingly as to draw the price of the land after them. For this is exactly what happened. All the talk of restoring the balance between the products of farming and of other industries, and of giving the farmers' output once more a purchasing power of one hundred cents, is simply a proposal to restore the relative prices which existed in 1913. These prices are, for the moment, looked upon as normal and just. Therefore, we should strive to restore them, not absolutely, but relatively at, say, 150 per cent of the level which then existed. If wheat was \$1 per bushel in that year, corn 70 cents and pig iron \$15 per ton, then present-day prices should be \$1.50 for wheat, \$1.05 for corn and \$22.50 for pig iron.

But the relative prices which existed in that year between agricultural products and other commodities did not always prevail. They were the result of a gradual increase in prices, both for farm products and for other commodities, which had extended over a period of 17 years. After all prices had reached the bottom in 1896, there was a rapid rebound from the lowest depth of the depression to 1899. This occurred despite unusually large crops, especially of wheat and cotton. The revival of

prices, coupled with the large output of agriculture, had restored the American farmer to prosperity. Yet for 20 years after 1899 the prices of agricultural products continued to rise the more rapidly than those of other commodities. If we accept the figures of the Bureau of Labor Statistics revised index number for wholesale prices, and use the year 1899 as a base, the increase in farm products and in all commodities other than farm products and food was as follows:

Year	Farm Products	Non-Agricultural Commodities
1899	100	100
1909	152	123
1913	156	127
1919	361	247
1921	194	204
1922	208	206
June, 1923	216	213

It will come as a surprise to most people that agricultural prices outran those of other commodities for 20 years, and that they bear the same relation today that they bore in 1899. Many will question the selection of that year as a basis of comparison. But there is much solid sense in the choice, for 1899, like 1923, was a year of prosperity following immediately upon a period of depression. All the evidence shows that the farmer was considered prosperous at that time. And his prices bore the same relation to those of other commodities that they do today. The Industrial Commission, appointed in 1898, reported in 1901 (Vol. 19, p. 30), after having taken elaborate and exhaustive testimony, that

* * * an examination of the facts * * * shows that the general condition of farming throughout the United States is prosperous as compared with conditions at different periods previous to and since the Civil War. Throughout the Central West it is stated that in most of the elements of agricultural prosperity the farmer is decidedly better off than at any previous period in our rural history.

In fact, the weight of evidence is to the effect that farm wealth has steadily advanced and debts declined. The mortgages of Kansas have been reduced to one-fifth of their amount of 10 years ago, and the interest rate on the balance has been reduced one-third.

If, now, we seek the general causes lying beneath the movements of prosperity and depression, as shown in prices, during the past two decades, we shall note the following: The period of prosperity from 1879 to 1882 was one of the most remarkable known to this country, and can be compared only with the recent period from 1897 to 1900.

Anyone who will take the trouble to read the periodical literature of 1899 and 1900 will have no doubt that the farmer was prosperous at that time. Nor was the balance then existing between the prices of agricultural products and other commodities the subject of critical comment anywhere.

The farmers of the United States were better off in 1913 than they had been in 1899, while in 1919 they must have been well off indeed. If the purchasing power of farm products per physical unit in 1899 be taken as 100, then in 1913 that purchasing power stood at 120 and in 1919 at 146. It still stands at 100 in 1923. Nor does the mere comparison of prices give an adequate index of the increase in the farmer's power to buy goods. Not only did the prices per unit of output of farm products as against manufactured and other commodities move in favor of the farmer; his volume of output likewise increased more rapidly than did the people employed in producing it. The index numbers of physical output for agriculture prepared independently by Edmund E. Day and Walter Stewart both show that the output of agriculture, measured in bushels, tons and gallons, had increased by more than 20 per cent between 1900 and 1913, and by 35 per cent in 1919. For the year 1922, they bid fair to exceed all previous years. The number of persons engaged in producing these products had increased by less than 10 per cent.

The real grievance which the agricultural community has, then, is not that the balance of 23 years ago has not been preserved, but rather that the farmer has lost some of the striking advantage which he gained in the 20 years culminating in 1919. Opinion seems to be almost unanimous that it would be desirable if the course of industry should preserve for the farmer his 1919 position. He is far from enjoying that position today. History shows that it is possible to have an increase in the price

of agricultural output which outruns that of other products without any governmental interference. After all, economic laws do work. For more than 20 years after the depression of the nineties they worked in favor of the farmer by increasing the purchasing power of his products, through price changes.

Certainly, in view of this situation, we should try to understand the forces which raised his prices during the first two decades of the century. An understanding of the facts will be more helpful than any amount of complaint and political accusation.

The movement of agricultural prices from 1899 to 1919 falls into three stages. The first pronounced advance came in the decade which ended in 1909. While the prices of other commodities in the Bureau of Labor index number of wholesale prices had stood above farm products at the beginning of the period, they were, by 1919, at exactly the same level. From 1909 to 1915, inclusive, the ratio between farm products and other commodities remained practically unchanged. From that point to 1919 they outran other commodities.

(TO BE CONTINUED)

CANADIAN GRAIN MOVEMENT

Apparently the danger of a grain blockade on the lakes has now been averted, so far as the quantity of shipping is concerned. The only difficulty now is, as one elevator manager at Fort William puts it, as to whether "the powers that be can keep the lower end of the spout clear." Boats are clearing from Fort William at the rate of 16 or 17 daily, carrying from 2,000,000 to 3,000,000 bushels of grain. The Canadian Government Merchant Marine has 10 of its boats in the trade. Rates asked for tonnage are considerably lower than they were, charters being made for 3 to 3½ cents for Bay ports and 3½ to 4 for Buffalo for the first two weeks of November, while charters for the latter half of the month run at about 5 cents. Five and a half cents is now quoted for Buffalo, including winter storage. Compared with the rates secured last year, those quoted above are about one-half the prevailing rates to Bay ports just before the close of navigation in 1922, when because of the large quantities of grain, they ran from 9½ to 11 cents.

The easing off in rates was contemporaneous with the entry of American vessels into the trade. Their arrival will probably insure the removal of all grain from the Head of the Lakes for which there is either a sale or eastern tonnage available. Much of the grain going down the lakes is consigned to Buffalo. Montreal storage is inadequate for the Canadian grain trade during the fall rush, so that dependence has to be placed on Buffalo. As long as Montreal, New York and other American ports have ocean bottoms to take away the grain, the upper lake ports have ample facilities to keep it moving. The export demand continues poor, however. Chairman Boyd, of the Board of Grain Commissioners, reports that he has found the grain trade of Winnipeg satisfied with the compromise arrangement with the American shippers, and that the effect of the ruling of the Board has already been to lower rates, which was what was aimed at. Both transcontinental railways continue to report all records being broken in the quantity of grain handled. During the months of September and October, loadings totaled 121,596 cars, representing 169,053,085 bushels, or over 10,000,000 bushels in excess of the quantity handled at the same period last year. The Canadian Pacific handled 100,307,085 bushels, as against 94,971,320 last year, and the Canadian National 68,746,000, as compared with 63,824,000 last fall.

It is stated from Winnipeg that Chairman Boyd has given Dr. Magill, secretary of the Winnipeg Grain Exchange, a guarantee of indemnification against any legal proceedings or damages by interested or private parties against the charter of United States vessels and filing of charters by shippers with the Grain Commission. With this guarantee of the Commission to recoup grain shippers for any loss the latter may incur by virtue of their guarantee to United States vessel owners against

legal action, it is expected that all shippers will fall in line and agree to charter American vessels for the grain trade.

COST OF RAISING WHEAT

Of making estimates of the cost per bushel of raising wheat there is no end. And they all differ, naturally so. Most cost sheets indicate that wheat raising is done as a matter of altruistic philanthropy, for they show that the farmer loses on every bushel. But occasionally one meets with an estimate of the other kind; and the *Commercial Review* of Portland, Ore., publishes such a one, furnished by a real dirt farmer. He gives figures based on hiring all the work, and omits figures covering interest, depreciation, salaries and the like.

Not to go into details, he gives the cost on yields of 10, 20, 30 and 40 bushels per acre. The cost of plowing, harrowing, etc., is \$5.75 per acre; threshing is 13 cents per bushel and sacks, 8 cents per bushel. On this basis the cost of producing wheat when the yield is 10 bushels per acre is 83.5 cents per bushel; at 20 bushels per acre, the cost is 49.7 cents per bushel; at 30 bushels per acre, it is 40.6 cents per bushel; and at 40 bushels it is 36.4 cents per bushel. They have such yields as these last on the Pacific Coast, which explains why wheat acreage increases out there in spite of low prices.

GRINDING CANADIAN WHEAT IN BOND

Considerable misapprehension exists as to the imports of Canadian wheat into the United States and the disposition made of such wheat. As a matter of fact, nearly 50 per cent of all the wheat imported into the United States from Canada since the Emergency tariff became effective on May 28, 1921, has been exported as flour. The U. S. Department of Agriculture points out that this wheat was milled in bond under the provisions of the tariff.

The total imports of wheat from Canada since the tariff became effective were 32,567,664 bushels. The quantity of Canadian wheat milled in bond during the same period was 15,453,624 bushels, or 47 per cent of the total imports. Imports in 1922 were large, when 22,642,959 bushels were imported. During the same year the quantity of Canadian wheat milled in bond was reported at 10,426,436 bushels, or 46 per cent of the total imports during the year. From January 1 to June 30, 1923, imports of Canadian wheat were 4,686,530 bushels. In that period, 2,837,008 bushels, or 61 per cent of the total imports were milled in bond.

The tariff act passed in 1922, contains two provisions which relate to the milling of imported wheat. One of these commonly known as the milling provision, provides that the entire mill, or unit of the mill handling the imported wheat be placed under bond. No duty is paid on the imported wheat provided the entire output of the mill is exported. Any flour or by-product from the imported wheat is subject to the prescribed import duty should it be entered subsequently for consumption in this country.

All of the Canadian wheat reported as having been milled in bond was milled under the milling provision. Canadian wheat milled in bond is statistically included in the general imports of the United States. All calculations, therefore, of imports of Canadian wheat that enter the United States for consumption should make allowance for wheat milled in bond, the Department points out. Flour manufactured from imported wheat is statistically included in the exports of domestic flour. Two flour mills in the United States grind Canadian wheat in bond. Both of these mills are located in the Buffalo district.

H. D. WATSON of Kearney, Neb., who farms about 8,000 acres of land in that state and is one of the largest Alfalfa growers in the country, says that no man ought to be allowed to raise a bushel of wheat in Nebraska, as it does not pay and it taxes the land unduly.

DUST COLLECTING EQUIPMENT FOR ELEVATORS

(Continued from page 335)

hoods over the belt loaders or flared hoods attached to the end of the loading spout. The type of installation selected depends upon the method of loading the belts. Where portable belt loaders are used the problem of applying suction becomes still more difficult and experimental work will probably be necessary to develop a suitable arrangement. The method of applying suction to trippers suggested in the next paragraph may also be applied to the movable belt loaders.

7. In the larger houses a conveyor belt and tripper are necessary to get the grain from the scale to the storage bin. In fact, there are few

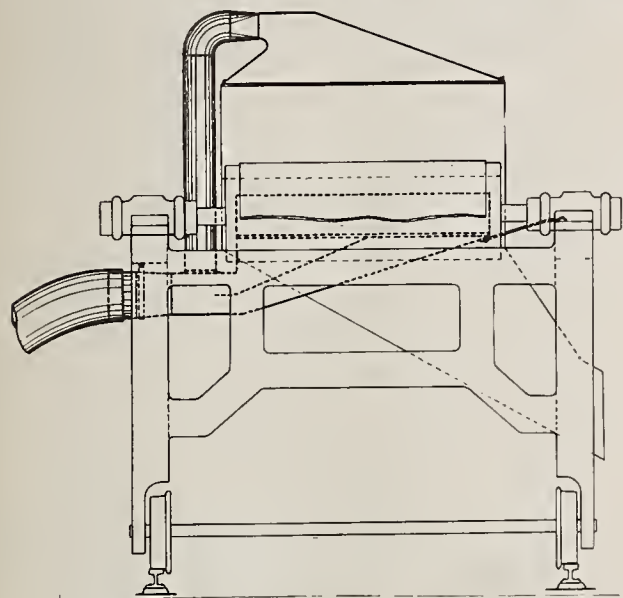

FIG. 6. APPLICATION OF PROPOSED SUCTION HOODS TO BELT TRIPPER

terminal elevators where at least one tripper is not used and this is ordinarily the dirtiest point in the plant. Throwing the grain from the belt at the tripper and discharging it into a bin where the displaced air escaping from the bin carries the light dust with it make this one of the dustiest

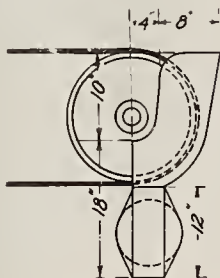

FIG. 7. BELT TAILING HOOD

steps in the grain handling process. But little experimental work seems to have been done to remedy this condition, except to vent the storage bins. Some progressive elevator operators have vented to the outside air every bin in the house. This highly commendable practice, of course, is applicable to closed bins only, although a suction hood has been suggested for open bins. A galvanized pipe 12 inches in diameter or large enough to conduct the air displaced by the grain entering the bin, which may be as much as 3,000 cubic feet a minute, should be installed so that it leads by the most direct route to the outside air.

A hood to exclude the weather completes one of the most effective and economical devices known for the control of dust arising during the filling of bins. Such vents should be installed on all bins, whether filled by spout directly from the scale or elevator leg or by tripper discharge from a conveyor belt. The control of the dust stirred up at the tripper is not so simple, because of the difficulties in making a satisfactory connection between the suction line and the movable equipment. In one elevator visited suction was applied to portable bin hoods through specially constructed 7-inch rubber hose which connected the hoods to an outlet of the suction system. This suggested the possibility of applying suction in the same manner to trippers and other portable equipment. Fig. 6 shows the method suggested.

Another system suggested consists of a suction

line directly over the path of travel of the tripper, with openings and sliding connection pipes at the points where the tripper is spotted for discharge to bins. Such installations must be simple, substantial and automatic or easily operated and the workmen must have an incentive to make the necessary connection.

8. Where grain is discharged from a storage bin onto a conveyor belt dust is naturally stirred up. Unless it is collected at this point it will be carried by the air currents following the belt into other sections of the plant. The same conditions

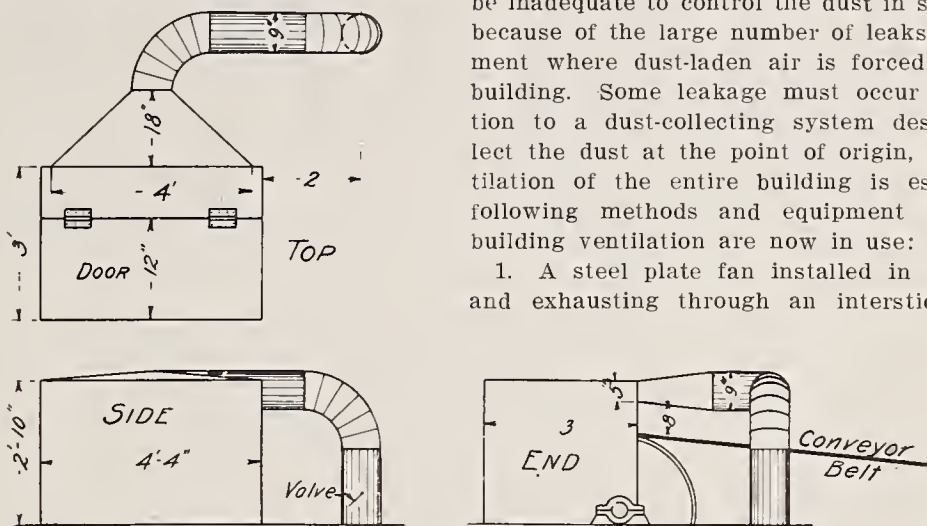

FIG. 8. DETAIL OF HOOD OVER WORKING FLOOR END OF CONVEYOR BELTS

exists here as at the point where the scale discharges to a conveyor belt and the type of hood recommended for that location under paragraph 6 should be used at the bin discharge.

9. At the point where the conveyor belt discharges into a shipper leg the same condition exists as at the boot of the receiving leg. The type of suction hood recommended for installation at the receiving boot should be installed at the boot of the shipper leg.

10. The same condition exists at the garner and scales in the shipping end of the house as in

the receiving end. The installation of vents from both the garner and scale hoppers is recommended as being the most practical solution of the dust control problem at this point.

11. At the ends of conveyor belts where the tailings, consisting of chaff and dust which cling

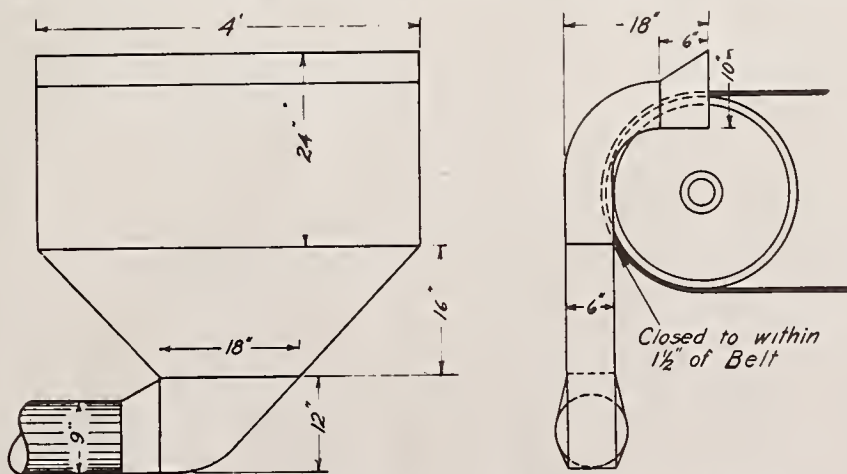

FIG. 9. DETAIL OF HOOD AT END OF OVERHEAD CONVEYOR BELT

to the belt accumulate, many operators consider suction unnecessary. Where long pipe lines are required to provide suction at such points the installation of hoods may not be advisable, but where a floor sweep system is provided the placing of a sweep inlet at this point or the installation of a hood which will automatically collect this dust

and chaff will be convenient and will save labor. At points where the belt tail is above the floor level and the falling dust forms a cloud, the use of a hood becomes necessary, both for cleanliness and dust explosion protection. The types of hoods designed for use at the ends of conveyor belts (Figs. 7, 8, and 9) will serve as a basis for the design of hoods to meet various conditions. Application of the principles can be adjusted as necessary.

COMMENT ON GENERAL VENTILATION OF GRAIN ELEVATORS

The best dust collecting system designed would be inadequate to control the dust in some elevators because of the large number of leaks in the equipment where dust-laden air is forced out into the building. Some leakage must occur and, in addition to a dust-collecting system designed to collect the dust at the point of origin, thorough ventilation of the entire building is essential. The following methods and equipment for providing building ventilation are now in use:

1. A steel plate fan installed in the basement and exhausting through an interstice bin which

has been extended through the roof of the building and covered with a hood. At least one air change an hour is made in the basement by this method.

2. Roof ventilators with revolving hoods to provide natural ventilation by outside air currents for the upper floors.

3. Disc fans installed in side walls to provide ventilation for the lower floors.

4. General ventilating equipment with suction fan, main duct, and inlet openings along the ceiling or walls.

5. Iron grating floorings in galleries connecting the storage section with the workhouse and ventilators at intervals on the roof of these same galleries.

6. Ventilators on the roof of the shipping gallery, with floor openings below covered with iron grating and equipped with wind reflector plates to increase the quantity of air passing through the gallery.

7. Ventilators over underground tunnels connecting sections of the elevator.

8. Steel curtain doors on the main floor of the workhouse.

9. Butterfly windows.

10. Louver windows.

It is reported that all of these methods and devices are giving thorough satisfaction. The cost of installation for many of them is small and the

results of using them are apparent in the improved condition of the plant. A practical demonstration was given in some cases by shutting off the fans. In a short time dust clouds began to form and distant objects became indistinct. When the fan was started again the air quickly cleared. Besides providing cleaner, fresher air in the building, their

use lowers the cost of dust removal by reducing the amount of sweeping and cleaning which would be necessary.

SUMMARY AND GENERAL RECOMMENDATIONS

The experimental stage through which the installation of dust collecting equipment in grain elevators is now passing and the evident need for a complete and effective system in every grain handling plant were brought out in a preliminary study of such equipment.

The application of suction to many points scattered over a large area has presented several problems. In order to maintain the desired velocities it is necessary to take into consideration the length of pipe required to connect the suction hood to the fan, the number of bends and elbows, and any obstructions which will produce friction losses. Leakage in the pipe lines is another cause of reduced effectiveness. The material to be handled must also be considered in planning a system because its weight will determine the velocity required to convey it.

Apparently no standard design of suction hood has been developed. Large shallow hoods, deep conical hoods, oval, square or round intakes, and in many cases only a direct connection of the suction pipe, were found. The hood or flared pipe connection is preferable except in cases where an enclosure is to be vented and it would be impractical to use a hood. Suction should not be applied at points where grain would be thrown or drawn into the intake with the dust.

If there is any possibility of grain or heavy dust being collected a trap or grain catcher should be installed in the line. The use of grain traps is suggested to overcome the objection to the application of suction ahead of the point of weight. The removal of grain or heavy material before weighing would, of course, be unfair to the shipper, but collecting the light floating dust which naturally escapes within the building during the handling process has little if any effect on weights and should be generally adopted. The installation of traps in the suction line which may be kept under seal would provide a means of inspection to determine whether or not heavy material was being removed from the grain. The ideal system, the design and installation of which should be the aim of every manufacturer of dust collecting systems, is the one which will collect all of the light floating dust at the point of origin, but no grain or heavy material which will affect the weight of the shipment. The development of such a system, which undoubtedly depends upon the proper design and installation of hoods and the control or regulation of the amount of suction applied, will solve one of the most important problems in fire and dust explosion prevention, the maintenance of cleanliness in the plant.

CLAIMS AGAINST THE M. & ST. L. RAILROAD

BY OWEN L. COON

The Minneapolis & St. Louis Railroad went into receivership on July 26, 1923. Claims which you have already filed with the M. & St. L. on shipments made previous to this date must be protected by the filling in and submission of a formal "Proof of Claim" to Howard S. Abbott, Special Master in Chancery, Federal Building, Minneapolis, Minn. The necessary forms for such purpose can be secured by writing to Mr. Abbott at the above address. These forms must be filled in and filed with him prior to January 1, 1923, or within the next seven weeks.

If, however, the claims have not yet been filed, on shipments originating either before or after August 20, 1923, I would suggest that they be filed, not against the M. & St. L. but against the railroad that delivered the shipment at destination. Under the provisions of the bill of lading, a claim can be filed against either the originating or the delivering carrier. The logical thing for any shipper to do when the originating carrier is in receivership is to file his claim with the delivering

railroad, thereby obviating the "red tape" that is always involved in receivership proceedings as well as the additional delay involved in obtaining payment. In the case of the M. & St. L., particularly, this is no more than just, since that railroad usually obtains only a very small portion of the haul, the carrier such as the C. & N. W.; C. M. & St. P.; C. G. W.; Rock Island, Illinois Central, Wabash, or C. B. & Q. delivering the shipments obtaining the long haul and the bulk of the revenue.

Considerable delay and inconvenience can be avoided by following the above policy. What has been said regarding shipments originating on the M. & St. L. applies equally to shipments originating on the C. P. & St. L.; C. & A., or any other carrier in receivership, and applies to all claims not yet filed, whether the shipments were made before or after receivership.

CO-OPERATIVE GRAIN STOREHOUSES IN NORTH AFRICA

BY H. FURGIER*

In most of the cereal-growing districts of North Africa, the agriculturist has no store-houses for his grain, and the farms which are generally 10, 20, or even 40 miles distant from the railway, only possess inferior means of transport and bad roads that are impassable during winter. Therefore, he is obliged, in order to avoid risk of loss and to be able to realize in good time the sums he needs for the following agricultural season, to clear off and sell his crop as soon as it is harvested and before the cart-tracks and roads at his disposal become useless.

In this way, all the products of the same district are thrown on the market at once, so that the farmer is unable to safe-guard his interests at the time of sale, the clearing-stations are obstructed and the cereal-growers consequently suffer serious injury.

The only remedy for this unsatisfactory situation is the construction of co-operative wheat "docks," or store-houses, in all centers which have no means of housing or disposing of their grain. These store-houses would enable the producer to send away his crops as soon as they are harvested at which time (August, September) he has at his disposal every means of transport. Further, he could raise money on his grain in order to obtain the sums he requires and have the cereals sold when he considers the market most favourable.

These advantages did not escape the notice of the South African farmer, who as long ago as 1918, realized that the storing and selling of his crops was of paramount importance.

We must not forget in this connection that after the harvest of 1918, many hundreds of thousands of quintals of wheat remained exposed to the winter storms as a result of lack of housing-room and means of transport, and were finally removed at great cost on the backs of thousands of dromedaries brought especially for the purpose from the South, where they had already been distributed, after spending the summer in the North.

As a result of these misfortunes, it was strongly urged that large storehouses should be constructed in Algeria, especially on the great grain-growing plain of Sersou, on the High Plateau (average altitude 2,600 feet), where over 1,000,000 quintals of wheat are annually produced. (A quintal is 220.46 pounds or, roughly, 3.67 bushels.)

This granary, which will have a capacity of 125,000 hectolitres, (about 100,000 quintals of wheat) was begun in 1922 and will be finished in time to house the harvest of 1923. Like the American elevators, it is divided into two parts, the one intended for storing the grain consists of 100 bins each with a capacity of 1250 hectolitres, a side measurement of 8 feet 3 inches and a height of 65 feet and the other part is specially arranged for the reception and storing of the grain, and houses the necessary machinery.

The grain is brought by the producer either in sacks, or in bulk, and after threshing it is weighed,

*From the *Revue agricole de l'Afrique du Nord*. Year 21. No. 183, pp. 69-74. Algiers, 1923.

poured into a hopper, raised to the separator (third floor) where it is all cleaned; on leaving the separator the weight of the clean seed is registered by an automatic weighing machine, the specific gravity of the grain is determined and the offal placed at the disposal of the consignor.

The grain is then raised to the upper conveyor and poured into the right silo; it is stored loose, according to its quality which is estimated from the specific gravity.

The silos open at the bottom and discharge their contents onto a conveyor that carries the grain to the receiving hopper; this grain is raised by an elevator to the bagger, put into sacks (on first floor) and graded. As the railway and high road are just below, the trucks, or lorries, can be loaded with the minimum amount of labor.

The quality and specific gravity of the grain in each silo being known, it is easy, by regulating the opening of the various silos, to obtain a homogeneous mixture composed of grain of the same type, and uniform specific gravity which allows of standardization being effected. In this manner large quantities of grain of uniform specific gravity will be able to be put on the market at once which will facilitate direct dealings with the flour mills, allow of better prices being obtained and tend to the suppression of middlemen. On the other hand, the Society of the Co-Operative Granaries at Sersou which considers that the peasant should not speculate, arranges for the stored grain to be sold monthly in fractions of 1/4, 1/5, or 1/6 during the 4, 5 or 6 months following the harvest. The money obtained is then divided according to the quantity and quality on consignment of the grain deposited by each farmer, all of the consignors thus profiting by the prices paid during the whole season.

Until these sales are effected, the agriculturist who finds himself short of money can obtain, on the security of his grain, any sums he may need which are readily advanced to him by the Banks of Mutual Agricultural Credit, or other banking establishments.

The above are the chief regulations for the working of these storehouses. The capital necessary for their construction which has been fixed at 1,250,000 fr. (10 fr. per hectolitre stored) has been obtained as follows: 500,000 fr. paid immediately by the co-operative members (5 fr. per hectolitre of grain stored); 500,000 fr. from the grant made by the Colony and 250,000 fr. also from the Colony in the form of a long term loan.

The large sum which the Colony has thus placed at the disposal of the co-operative storehouse-silos of Sersou shows the importance attributed by the Algerian Government to the formation of this Co-operative Society. We may consider that but for this assistance, the first storehouse with elevator would not yet have been built. For the construction of those to be built in future, if the budget permits, the Algerian Government intends as a general rule to pay one quarter of its contribution in the form of a grant and one half in the shape of a loan.

With such encouragement, there is no doubt that other similar storehouses will soon be built. So far, in addition to the Burdeau storehouse, another with a capacity of 10,000 quintals has been constructed at Brazza (Algiers) owing to the initiative and perseverance of M. Rodet. Further storehouses, at Thiersville (50,000 quintals), Maalifs (25,000 quintals), Bel-Abbès (100,000 quintals), Relizane (100,000 quintals) and Inkermann (40,000 quintals) are under consideration, or are shortly to be built.

The "Société des Docks-silos coopératifs du Sersou," after making a careful study of the different storehouses for grain used in various countries, have come to the conclusion that the German "Kornhauser," though adapted to countries with small holdings, are not suitable for the storage of the large quantities of cereals grown on the High Plateaux of Algeria. It has therefore decided to make the first grain storehouse of the type of the American elevator and provided with the latest and most improved apparatus for cleaning and sorting the grain.

NEWS LETTERS

DULUTH

S. J. SCHULTE - - CORRESPONDENT

ONLY two changes were reported in the personnel of office managements on the Duluth Board of Trade during the last month. F. B. Wells, in charge of the Peavey interests at Minneapolis, has taken over the membership of A. L. Searles and has become vice-president of the Globe Elevator Company. Mr. Searles, who retired, is now heavily interested in the grain trade at Winnipeg. Mr. Wells visited this market recently and made an inspection of his company's elevators here. Sidney A. McPhail, one of the veteran traders on the Duluth market, has disposed of his membership to Benjamin Stockman, manager of the Duluth-Superior Milling Company.

William D. Jones, representative of the Hallet & Carey Company on this market, is on the trading floor again, fully recovered in health after a serious illness during which he underwent an operation at the Drs. Mayo Hospital at Rochester, Minn. His many warm personal and business friends extended him a hearty welcome upon his resumption of his duties.

Stephen H. Jones, a former president of the Board of Trade, but now operating on the Chicago Board of Trade, was a recent visitor on this market. He expressed the opinion that the movement of corn from western and southern Minnesota to the markets late this fall and during the winter would put all previous records in the shade and make up to some extent for the falling off in the wheat traffic. From information he had gathered, he stated that Minnesota corn is likely to command the best prices this season on account of its average high quality.

Elevator men here are looking forward to handling a considerable volume of Montana Hard wheat during the winter months. Some of the houses here have been receiving advices from their Montana connections in districts that were fortunate in escaping the drought and succeeded in threshing satisfactory crops. W. J. McCabe of McCabe Bros. & Co., who own a chain of elevators on the high lands of Montana, where another failure was experienced through a grasshopper plague last summer, commented upon the hard luck experienced by farmers in that territory over a series of years. He expressed the hope that any farmers out there who have been able to hang on to their land holdings would be eventually able to recoup themselves through going in for cattle raising and some branches of mixed farming.

Grain operators at this point have been deeply interested in the possibility of opening up direct shipments of grain by water to New York and the avoidance of delays and additional cost of handling at the Buffalo elevators. On her first trip from Duluth to New York, the McDougall Terminal Company's Diesel motor steamer *Twin Cities* had included in her cargo, 18,000 bushels of Durum loaded at the Itasca Elevator at Superior and consigned to the Hansen Commission Company at New York. Satisfactory time was made on the run down the lakes to Buffalo and through the New York State Barge Canal and the freight rate made enabled a saving to the shippers below the current lake and rail rate and the elevator handling charges at Buffalo involved in it. Operators of the new boat line have expressed themselves as sanguine that traffic in perishables and other freights can be developed to such an extent as to warrant augmenting the service next season by putting on additional motor boats of 2,000 tons' canal size capacity.

R. M. White of the White Grain Company reported that he had been looking into the facilities afforded by the line for carrying feeds from this market to points in New York state. As he sizes the situation up, the feasibility of the routing has simmered down to a question of the freight rate being placed at a level that would enable competition with the lake and rail route.

Marketing conditions on this market have gone from bad to worse during the last few weeks. Export demand for Spring wheat and Durum has fallen away to a bagatelle, according to Percy Ginder of the Barnes-Ames Company and Watson S. Moore. They

attributed that condition to the impossibility of competing with Canadian Northwest wheat of high quality offering in export channels at several cents a bushel under American grain. Inquiry for Durum wheat that had been active at one stage has dropped off sharply.

An increasing recent development was the unloading of two small cargoes aggregating 175,000 bushels of Canadian Spring wheat at the Consolidated Elevator here. The wheat, which was shipped from Fort William, was part of a lot of 600,000 bushels bought by Minneapolis millers. It has already been reshipped by rail to Minneapolis and any other lots will be forwarded promptly, the elevator interests asserted. The wheat was of good quality, but as a result of part of it having been frosted, it was given No. 3 Northern grade. A representative in Duluth of one of the Minneapolis milling companies bringing in the wheat, asserted that his people had during the last few years made a practice of importing Canadian wheat for mixing purposes and that they would probably continue to do so to some extent, no matter what the cost might be.

With stagnation prevailing in shipping circles, the vessels interested are reported to have been marking down their rates in the effort to promote charterings. Bookings of space for wheat at as low as 3½ cents a bushel at Duluth for Buffalo delivery, were noted during the last week. The general impression here is that a rate of 4 cents a bushel to include winter storage will be made for late shipments before the close of navigation.

Steamship interests here have been feeling much better lately on account of an agreement having been made with Canadian shippers that has enabled them to enter the grain carrying trade between Fort William and Buffalo. From present indications, it is thought that American steamers will be chartered freely for storing grain at the Canadian Head of the Lakes to relieve the handling situation up there. Elevator interests here have also strong hopes that substantial quantities of Canadian grain will be received in bond here during the winter months, as the plugging up of the elevator capacity up there shortly after the close of navigation is regarded as inevitable.

Dealers here who started in to specialize in rye handling early in the season have been sadly disappointed so far. Foreign demand was developing nicely early in the fall and it appeared to be probable that a fair trade would be put through. The market later received a shock through the demoralized German situation and advices that Russia had made large sales of that grain to Germany and to Scandinavian buyers. Exporters' interest in that grain has consequently dried up and with limited shipments to the East stocks in the terminal elevators have been steadily accumulating and they now aggregate 5,600,000 bushels. The rye market situation was claimed to have furnished almost as great a market tragedy as oats did two years ago. Holders of rye have been caught in the falling market.

A late incident in the rye trade here was the sale of a lot of 240,000 bushels to the Armour Grain Company for delivery at Chicago. It was loaded out at the Cargill Elevator Company's house in Superior. This was asserted to have been the first occasion on which a shipment of rye was made from here to Chicago by lake and it was claimed to have been a special transaction.

With the more favorable freight rates now in effect on coarse grains to this market from Southwest territory, elevator interests here have strong hopes of handling a fair tonnage of oats during the winter. Some inquiry for space has been received and negotiations now on are expected to lead to results.

Walter McCarthy of the McCarthy Bros. & Co. received a package from Germany recently containing stamps to the value of 77,000,000 marks to cover the postage. That incident was regarded as demonstrating the hopelessness of looking for anything tangible in the way of opening up trade relations with Germany until the financial situation over there has been stabilized.

Both wheat and coarse grains being marketed here continue to carry heavy dockages for weeds, and considerable cleaning is necessary at the elevator plants. A commission man sold a car of flax recently carrying 41 per cent dockage. A campaign to promote measures to eradicate the weed pests is being urged.

TOLEDO

C. O. BARNHOUSE - CORRESPONDENT

RECEIPTS of grain are only moderate, while there is a good demand for good grades of corn and oats and considering the fact that receipts of corn of high moisture content are taxing drying facilities this class of corn is selling well. Good milling grades of wheat are sold without difficulty. Flour sales are rather slow and the feed demand is light although the Toledo mills have been producing about 80 per cent of their capacity for several months.

Cyrus Coup and Fred Mayer spent several days in Chicago recently.

C. R. Heaney, of the Christian Mills, Minneapolis, Minn., was in Toledo two days last week.

Fred O. Paddock returned November 1 after spending several weeks in California.

Alphonse Mennel, president of the Mennel Milling Company, left October 31 for Florida, where he expects to spend the winter.

David Anderson, president of The National Milling Company, returned November 7 from a seven weeks' trip to Europe.

George Forrester, of Kasco Mills; Lester Howard, of C. A. King & Co., and Joseph A. Streicher, of J. F. Zahm & Co., attended the fall convention of the Ohio Grain Dealers Association at Columbus.

J. E. Delaney, of Thomson & McKinnon's Chicago office, relieved James Mattimore, local manager, from October 29 to November 3 while he took a vacation.

Charles Keilholtz, J. L. Doering, J. A. Streicher, W. W. Cummings and George Woodman from the Toledo market, attended the monthly meeting of the Northwestern Ohio Farmers Grain Dealers Association at Fostoria on November 5. They report a good attendance and not least of all a splendid lunch. Corn was the principal subject of discussion at the meeting. The high moisture content of the corn and the lack of drier capacity sufficient to dry it as fast as marketed is worrying the managers.

Dudley M. Irwin of Buffalo, N. Y., spent November 5 on the trading floor here.

Charles W. Baum, of the Rosenbaum Bros., spent several days this week in Toledo looking after the interests of his firm.

Spontaneous combustion caused a blaze in the dust chamber of the Fostoria Storage & Grain Elevator Company's plant at Fostoria, October 30, but it was promptly extinguished by the fire department without much loss.

G. B. Martin has resigned as miller at the Nevada (Ohio) Flour Mills after 43 years' service. He and Mrs. Martin expect to leave November 15 for an extended visit with their son and daughter in California and Arizona. J. B. Johnson succeeds him at the mill.

Luther C. Clark was named as receiver for the Hancock Co-operative Elevator & Supply Company at Findlay, Ohio, upon petition of the Buckeye Savings Bank and the American-First National Bank of Findlay. The banks claim an indebtedness of \$36,000 and allege that the concern is insolvent. The banks had obtained cognovit judgments before the receiver was appointed.

L. G. Macomber, traffic commissioner of The Toledo Produce Exchange, left for Chicago Monday and has a big week's work ahead of him in the interest of Toledo shippers. Tuesday he is to appear before the Central Freight Association to oppose a rule which is detrimental to the Toledo market in the use of reshipping rates. That afternoon he will meet with representatives of the terminal markets of the country to discuss the plans for a hearing before the Interstate Commerce Commission on the reasonableness of rates on grain

and grain products throughout the entire country. Wednesday and Thursday he attends the annual meeting of the National Industrial Traffic League and on Friday he will meet with the officers and Executive Committee of the 10 regional shippers advisory boards of the American Railway Association and a group of railroad presidents.

The Waterways Committee of the Chamber of Commerce, of which Harold Anderson, vice-president of The National Milling Company, is chairman, has inaugurated a publicity campaign to acquaint the citizens of Toledo with the possibilities in the future importance of the city as a lake port if an intelligent and progressive development program is carried out.

J. C. Harmon & Son, of Oakwood, Ohio, have purchased from John Wickenhiser & Co., the elevator site at Goodwin, Ohio, where the plant was recently destroyed by fire.

Two 10-acre fields of corn in Wood County, Ohio, which had been entered in the 100 bushel per acre contest, were measured by County Agent Lewis of Wood County and tested out 98.14 and 99 bushels, respectively. The former was owned by A. C. Hoyt of Fostoria, and the latter by H. O. Rosendale, of Bloomdale.

KANSAS CITY

B. S. BROWN - - CORRESPONDENT

INTERSTATE Commerce Commission representatives recently held a hearing in the office of the secretary of the Board of Trade on the protest of the grain exchange against the attempt of the Missouri Pacific Railroad to restrict application of through rates on grain from points on its own line to Texas, to through routing over its own rails from points of origin to junction points with connected lines south of Kansas City. The Kansas City Board of Trade, through Walter R. Scott, its transportation commissioner, is maintaining that the action on the part of the Missouri Pacific is damaging to this market at large and is holding that the through rates in question should apply in connection with all lines diverging from Kansas City, with Kansas City the junction point on this traffic. This will give Kansas City shippers their choice of all available routes south, instead of being confined to the Missouri Pacific only. R. A. Jeanneret, chairman of the Board of Trade Transportation Committee, testified for the exchange.

E. D. Bigelow, for 27 years secretary of the Kansas City Board of Trade and a conspicuous figure in the



E. D. BIGELOW

grain trade of the Southwest, has been promoted to the position of assistant to the president.

W. R. Scott, transportation commissioner of the exchange for three years, will succeed Mr. Bigelow as secretary.

Mr. Bigelow sent in his resignation to the directors some time before the action was taken, but no announcement was made as the board officials were re-

luctant to accept it. It was finally accepted only when it was learned he would take the newly created office of assistant to the president, continuing his relationship with the exchange. He will be 86 years old December 5.

Mr. Bigelow was born December 5, 1838 at Sherborn, Mass., a suburb of Boston, where he began his career as a shipping clerk. For 18 years he headed the firm of E. D. Bigelow & Co., ship brokers in Baltimore. He came to Kansas City 38 years ago and was interested in a real estate business for several years. He purchased a membership in the local exchange September 17, 1889, for \$25. In 1896 he succeeded W. D. Charge as secretary. He has been active in Y. M. C. A. affairs for many years.

The appointment of Mr. Scott will result in combining the offices of the transportation commissioner and the secretary. Mr. Scott, an authority on rate and transportation problems started his career with the Santa Fe and Missouri Pacific Railroads with which he had 15 years service, a considerable part of this time being chief rate clerk at Topeka under A. R. Koonts, then general freight agent of the Santa Fe. From 1915 to 1917 he was in charge of the rate division of the public utilities commission of Kansas under the late Judge A. E. Helm. Numerous cases have been fought by Mr. Scott before the Interstate Commerce Commission at Washington, and he has been constantly in rate litigation practice. Later he became associated with Clifford Thorne, of Chicago, who maintained a practice of law and was a national figure several years ago in railroad litigation work. He was later engaged as a rate specialist by the Western Petroleum & Refiners Association, which was composed of members of the midcontinent oil field.

On May 1, 1920, Mr. Scott was appointed Transportation Commissioner of the Board of Trade, where his work has caused much favorable comment. Mr. Scott was born August 18, 1885, in Lynn County, Kan. He is a member of Ivanhoe Masonic Lodge, Kansas City Athletic Club, Traffic Club and is also a member of the Missouri Bar Association.

Henry Lichtig, one of the local kafir kings, received the season's first car of new milo October 9 from Hooker, Okla.

Ernest R. Downie, secretary of the Kansas Wheat Growers Association, is an applicant for membership in the Kansas City Board of Trade. W. W. Young of the Association originally made the application, but withdrew because of a Board of Trade ruling that members of the exchange representing co-operative societies must be officers and stockholders. Young was elected assistant secretary while the application was pending.

Prize winners in the Board of Trade's annual Columbus Day golf tournament were: R. Y. Smith, Merle Howard, Harry Schilling, W. B. Lathrop, W. D. Walters, Frank Ewart, F. W. Lake, E. O. Bragg, Allen Logan and Walter Izzard. The prizes consisted of sweaters, golf hose and a hat.

The season's first car of new corn was received October 15 by the Sampson Grain Company from Vleits, Kan. It was ear corn. It sold to a feeder at 86 cents per 70 pounds.

In return for a dollar bill which he sent to a correspondent in Amsterdam, Allen Logan recently received one billion marks of various denomination. The postage on the package was 2,500,000 marks.

A. L. Ernst of the Ernst-Davis Commission Company has purchased the interest of Cort Addison of the Addison Grain Company and will take over active management of the latter firm, continuing it under the present name. Mr. Addison expects to form a new company.

Archie R. Aylsworth, formerly secretary of the Federal Grain Company, which was recently purchased by the Norris Grain Company, has been elected vice-president of the Woods Investment Company, Kansas City. He has not yet disposed of his membership in the Board of Trade.

Application for membership in the Kansas City Board of Trade has been made by Cecil E. Munn, sales manager of the Southwestern Wheat Growers Association, which is a selling organization for the Oklahoma and Texas Wheat Growers Association, with offices in Enid, Okla. The membership, it was said, has no connection with any plans of the Association and was purchased individually by Mr. Munn. The membership formerly was held by Alla Cunningham of the Simonds-Shields-Lonsdale Grain Company and was purchased for \$7,375, or \$75 higher than the last sale.

Herbert C. Monk, formerly with Goffe & Carkener, has left the grain business to join his father in the poultry and egg trade. The membership held in his name has been posted for transfer to R. A. Wood of the same firm.

Wheat receipts at Kansas City in October, 4,708 cars, were 7 per cent larger than in September and 10 per cent smaller than a year ago. The 10-year October average was exceeded by 5 per cent. Corn arrivals were about the same as in the month before, a year

ago and the 10-year average. Oats receipts were the third largest on record for October and exceeded the average by about 75 per cent.

C. H. Benton, president of the Benton Grain Company, suffered a dislocated knee recently when he fell at his home.

J. B. Racken, of the Kansas City office of Lamson Bros. & Co. recently was awarded third prize in a lawn, flower and shrubbery contest.

No export trade in wheat of importance has been reported at the Gulf recently and none is expected. A few loads are purchased occasionally to fill out cargoes.

The possibility of bringing Canadian wheat to Kansas City has been under discussion a number of times the past few weeks and at times may have



W. R. SCOTT

been a factor in the market. The proposition was explained in this manner: The rate from Duluth to Kansas City is 21 cents a bushel and from Kansas City to Galveston it is 18 cents a bushel. Canadian grain could be brought to this market, milled here and sent on to the Gulf for export on the same billing, as provided by the milling-in-transit rules, making the rate on Canadian wheat only 3 cents more than on domestic grain. Several local mills are said to have substantial bookings ahead in the West Indies, chiefly Cuba and Porto Rico, and to other countries that take Gulf billing. Several times recently the Kansas City market has been within a few cents of an "import" basis and if it reaches that point mills say they will use some Canadian wheat.

LOUISVILLE

A. W. WILLIAMS - CORRESPONDENT

MOVEMENT of new corn into the market is beginning to liven things up a little, although new corn is quite damp, and is moving to the dryers. Dried corn is moving as fast as it is dried, and drying services are in demand. New corn as a whole is promising, much of it being of good quality, although a little of the new corn is light in weight. A period of fairly warm but quite damp and cloudy weather hasn't helped reduce corn moisture any, and until the weather becomes colder and there is more wind, country offerings will be quite damp.

The Kentucky Public Elevator Company reports a full house, its storage capacity being practically filled up as there are now about 400,000 bushels of wheat; 100,000 of corn; 30,000 of oats, and 4,000 of rye on hand. The company is drying about 10,000 bushels of corn daily, as against a capacity of 30,000 bushels, but has been limited in accepting drying business on account of the crowded condition of the elevator and lack of space for handling. Present inbound movement is around 12 to 15 cars a day. Only immediate movement drying is being handled as a result.

A feature of the month is the final retirement of the Edinger & Co., interests from the grain, hay, flour

and feed industries. This is one of the oldest of the local houses, and for many years has been a large jobber of such lines. A few years ago the company disposed of its flour business. Andrew Edinger, one of the founders of the house, died some four or five years ago, shortly after retiring and turning the business over to his sons. About three years ago Albert Edinger withdrew to establish the Edinger Motor Parts Company, handling lines of the Continental Motors Company, and other big producers. A few weeks ago the company sold its local elevator and warehouse, feed manufacturing plant, etc., to the Ohio Valley Grocery Company, and planned to secure a new elevator. In the meantime an opportunity bobbed up whereby the Edinger brothers were able to secure the Studebaker Automobile agency, and they incorporated the Edinger Brothers Auto Company, composed of O. W., J. P., and W. E. Edinger. Another deal was arranged whereby the company's business, stocks on hand, etc., was disposed of to Henry Fruechtenicht, for many years prominent in the local hay, grain and feed jobbing circles. This closes out the Edinger interest in the hay, grain and allied lines, and removes an honorable name from the trade.

Henry Fruechtenicht, who takes over the Edinger business, owns and operates two local elevators and warehouses. The uptown plant at Hancock and Franklin streets, has a bin capacity of 50,000 bushels, and floor capacity of 50 cars of hay, sacked grain, etc. The downtown or southern plant at Seventh and Jarvis streets, has bin capacity of 20,000 bushels, and floor space for 20 cars of hay, feed, etc.

Louisville retailers as well as jobbers have been a little busier the past few days as a result of the opening of the fall racing season here on November 7, stall room at the Douglas Park and Churchill Downs tracks having been well occupied before the opening of the meeting, while a larger number of horses will quarter here over the winter than usual, due to calling off of the Havana, Cuba, race meeting, which would have taken a good many horses from Kentucky.

The two-story frame plant of the Louisville Hay, Grain & Coal Company, 815-17 South Twenty-sixth street, was destroyed by fire which started at 5 o'clock on the evening of November 9, and burned slowly until 2 o'clock the next morning. There were about 2,000 bales of hay in the building, and firemen were unable to reach the heart of the flames. A considerable quantity of grain and feed was destroyed.

The Louisville market on corn has been working lower as a result of new corn moving in. No. 5 new corn, Mixed, is selling in car lots, bulk, at 82 cents, with Yellow carrying a three cent premium. Dried to 14 or 15 per cent moisture content and grading at No. 3, new corn is quoted at 95 cents for Mixed, or 98 cents for Yellow, and old corn is selling at right around a dollar. Oats are quoted at 46 cents for No. 3 White, 47½ to 48 cents for No. 2, and Mixed at 45 cents for No. 3. Sacked corn is figured at 4½ cents a bushel higher and oats 2½ cents higher.

Feed prices show bran at \$33 to \$34 a ton, sacked; mixed feed, \$34 to \$36; middlings, \$34 to \$38; hominy feed meal, \$41; cracked corn, \$44. Flour orders are heavy, and orders in hand of local mills are double what they were at this time last year in some instances. Production of feed is heavy and millers are trying to develop mixed car business.

Hay prices are stiff and hay is in good demand. No. 1 Timothy is quoted at \$25 a ton, with No. 2, \$24; No. 1 Mixed, \$24; No. 2, \$22.50; No. 1 Clover, \$24; No. 2, \$22; wheat and oat straw, \$13; rye straw, \$16.

Henry E. O'Brien, 51 years of age, grain dealer of Owensboro, Ky., and Miss Mary Louise, 36 years of age, of the same city, were married in Louisville, on November 8.

Allen Zaring, of Richmond, Ky., miller and grain man, recently went to Harrodsburg, Ky., to aid in the organization of a Rotary Club in that city.

It is reported that Early & Daniel, of Cincinnati, have a deal on for taking over the elevator of Wolcott & Matlack, Winchester, Ky., formerly the Fleischman Malting Company's local grain handling plant, which was sold to the present owners about a year ago. It is reported that the plant originally cost around \$300,000, but was sold to the present owners at around \$50,000.

Mrs. Margaret Brumleve, mother of Ben Brumleve, formerly prominent retail hay and grain dealer, now in the auto truck business, and mother of M. W. Brumleve, secretary of Callahan & Sons, local grain dealers and elevator operators, was killed in Louisville on Sunday, October 20, when struck by an automobile while crossing Broadway at Sixteenth.

At Lexington, Ky., on November 8, Judge Robert Worth Bingham, of the *Louisville Courier Journal* and *Louisville Times*, leading spirit in the Kentucky farmer co-operative movements, announced that a wheat membership drive for the proposed growers' pool will open in Indiana shortly, and will be followed by drives in Ohio, Illinois, Kansas, Nebraska and other wheat producing states. Judge Bingham, vice-

chairman of the Advisory Committee, stated that the work has made a good start along organization lines, and looked quite promising. Bingham was a leader in the movement whereby the tobacco growers of Kentucky and adjoining states pooled.

The roller mill of the Moss Milling Company, Greensburg, Ky., was one of several buildings burned on October 30. There was no insurance on any of the property.

BUFFALO ELMER M. HILL CORRESPONDENT

ELEVATOR companies at Buffalo expect that the Royal Grain Inquiry Commission appointed by the Canadian Government to investigate charges that lower grades of American wheat are mixed with No. 1 Manitoba Northern and other Hard wheat grown in the Canadian Northwest somewhere en route between western shippers and Liverpool, will give them a clean bill of health. The Commission, of which Judge W. J. H. Turgeon of Prince Albert Saskatchewan is chairman, is reported to have been impressed with the co-operation extended by Buffalo elevator companies and grain forwarders and those in close touch with the local situation say that absolutely no evidence of alleged illicit mixing was found in Buffalo.

Grain experts in Buffalo believe there is no basis for the charge made by growers in the Canadian Northwest and traders in the Liverpool market. All Canadian grain routed in bond through the United States for export to England is handled with the greatest care by Buffalo houses and is inspected by United States customs officers to see that none is diverted into American markets through illicit channels.

While in Buffalo, the Royal Grain Inquiry Commission was shown how the bonded wheat is unloaded from lake grain carriers from Fort William and Port Arthur into separate bins in terminal elevators and re-loaded into freight cars for shipment to the Atlantic Seaboard at New York for export to the Liverpool market. The Commission left Buffalo for New York to inspect conditions at that port and then returned to Fort William at the Canadian Head of the Lakes where the big mixing houses at that port were carefully inspected.

Judge Turgeon told the writer in Buffalo that although the commission has been investigating conditions all along the route, he had found no concrete evidence of any illicit mixing of grain. He would not indicate, however, what would be the findings of the Commission in its report to the Dominion Government upon the completion of its trip of inspection.

Fire in the casing of a conveyor at the Evans Grain Elevator on the Buffalo waterfront caused damage estimated at \$3,000 early this month. The conveyor is a large tube about 30 feet high and the fire was inside that tube so the firemen were forced to pump water into the tube for several hours before the blaze could be extinguished. At no time was the elevator itself in danger.

Leslie R. Veatch of Buffalo, a milling engineer with offices in the Prudential Building, who has supervised the construction of flour mills and feed plants in many parts of the country, and his company, Leslie R. Veatch, Inc., have filed voluntary petitions in bankruptcy in United States District Court. In his individual petition, Veatch lists liabilities of \$19,681 with assets of \$3,505, while in the corporation of which he is president and general manager, liabilities are scheduled at \$32,087 with assets of \$14,796, of which accounts due are \$9,575. The schedules show that stockholders have invested \$14,200 in the stock of the corporation and among the assets listed is a claim against the Grange League Federation Exchange, Inc., of Buffalo, a co-operative feed dealers' organization, amounting to \$6,620. The papers show suit has been brought to recover the amount of the claim. The liabilities consist largely of accounts due milling machinery companies for equipment purchased for various plants over which Veatch had supervision.

The Eastern Steamship Corporation has been organized by officials of the Eastern Grain, Mill & Elevator Corporation of Buffalo with an authorized capitalization of \$1,000,000 to engage in the Great Lakes and St. Lawrence River grain carrying trade. The directors of the new corporation are Judge Louis B. Hart, Nisbet Grammer, J. J. Rammacher, Edwin T. Douglas, Norman B. MacPherson, Norman P. Clement, George J. Grammer and John B. Richards. The new corporation is separate from the Eastern Steamship Company, Ltd., which was organized about a year ago by the same interests to engage in the grain carrying trade between Buffalo and Montreal, via the Welland Canal. The new company has purchased several large Great Lakes grain carriers and has started to move grain from Fort William and Port Arthur at the

Canadian Head of the Lakes to Buffalo. Among the boats purchased by the new corporation are *G. J. Grammer* of 250,000 bushels' capacity, the *W. L. Brown*, the *Mary Elphicke* and the *G. Watson French*. These boats have a combined carrying capacity of upwards of 1,100,000 bushels, which is equal to the carrying capacity of the fleet of 10 ships built in England and Scotland for the Buffalo-Montreal grain trade operated by the Eastern Steamship Company, Ltd.

The United States Supreme Court has refused to review cases in which it was sought to have it determine whether a company operating a grain elevator must retain its full share of the division of through railroad rates which include elevator, storage and loading charges, or whether it may refund a portion of its share to shippers without subjecting itself to the charges of rebating, as raised by the Delaware, Lackawanna & Western Railroad against Spencer Kellogg & Sons, Inc., operating grain elevators along the Buffalo waterfront. The case was being watched with a great deal of personal interest by owners of Buffalo grain elevators. The Kellogg company notified the railroad in August, 1912, that it would charge its own rate for such grain as went through its elevator. It elevated several cargoes of grain and the Lackawanna refused to pay its charge of one cent per bushel unless the Kellogg company would agree not to pay back any portion of the one cent to the shipper of the grain. The Kellogg company refused, taking the position it could do as it liked with its own money. The railroad claimed that the one cent being included in the railroad rate for which tariffs were filed, any payment made to influence the consignment of grain through the Kellogg elevator would constitute an unlawful rebate and render the railroad liable for a violation of the law. The Buffalo elevator company brought action against the Lackawanna to recover money earned by the elevator and collected by the Lackawanna, but which the railroad refused to pay the Kellogg company. At the trial, the presiding judge ordered a verdict in favor of the elevator company. The Appellate Division affirmed the verdict and the Court of Appeals affirmed the judgment of the Appellate Division. Now that the United States Supreme Court has refused to review the case, the contentions of the Kellogg company are upheld and the case is closed.

Owners of grain elevators, feed mills and flour mills in the Buffalo trade zone are co-operating with the Safety Bureau of the Buffalo Chamber of Commerce in staging a series of safety first lectures this winter for employes of these plants. H. J. Aldrich of Spencer Kellogg & Sons, Inc., is chairman of the committee arranging for the lectures of interest to employes of elevators and mills. The safety lectures are part of an intensive campaign to be undertaken in Buffalo this winter to promote safety in all fields of industrial activity.

All records for the movement of grain out of the terminal elevators at Fort William, Ont., were broken early this month when close to 3,809,000 bushels were loaded onto lake grain carriers in a single day, it was announced by representatives of Buffalo elevator interests who were advised to be prepared to handle the cargoes upon their arrival at Buffalo. It was stated that all but 215,000 bushels of the shipments was wheat. With the regular navigation season closing November 30, the grain movement from the Canadian Head of the Lakes has jumped from an average of 1,500,000 bushels daily to more than 2,500,000 bushels daily and it is expected this will increase as the season advances. The situation at Port Arthur is reported to be somewhat similar, shippers being exceedingly anxious to get their crops East before the close of navigation to avoid the long trans-Canada rail haul.

Figures recently announced by the Canadian Government show that \$400,000 revenue is received every year through the operation of the Dominion-owned grain elevators at Port Colborne, Ont., and from wharfage dues and fines at that port. Canada's canal system, which allows the movement of grain via an all-water route from the Canadian Head of the Lakes to Montreal, including allied inland waterways cost upwards of \$4,000,000 a year to maintain, but no tolls are collected on any of these artificial streams. All these waterways can be traversed by grain carriers not exceeding 14-foot draft.

Another step to aid the grain interests at Buffalo and make Buffalo the milling center of the country has been completed by the Pillsbury interests of Minneapolis in the sale of their rights in the Saint Anthony water power development to the Northern States Power Company, according to announcement made by the Buffalo Chamber of Commerce. The Pillsbury and other millers apparently have realized for some time that Buffalo is strategically the center for the milling industry due to the fact that transportation of the finished product from Minneapolis to the great Eastern consuming markets has not been adequate. There has been no difficulty about transportation during the summer while the lake lines were running, and raw material could be kept moving to points adjacent for consumption of the finished prod-

uct, but new economic conditions have set to work and now rail transportation of the finished product in the winter no longer gives an answer to the problem. Thus, while the western milling centers are great clamorers for the St. Lawrence ship canal, it already is apparent that they are going to lose some of their business to Buffalo, which is blamed more than any other city for the opposition to the project.

The Buffalo General Electric Company, which supplies electric power to western New York, has started the construction of an electric sub-station of 5,600 kilowatts capacity in the so-called elevator and mill district on the island. The new station, which will be completed and in operation next year, is made necessary by the increased business at the grain elevators and new flour mills which are locating in that part of the waterfront district.

The New York State Department of Purchasing has awarded the Globe Elevator Company of Buffalo the largest contract of its kind ever placed in this state. It provides for a contract for grain and feed to supply various New York state institutions and is worth approximately \$50,000.

At a special meeting of stockholders of the Consolidated Feed Dealers Association of Buffalo, held in the offices of the company in the Chamber of Commerce October 31, it was voted to change the name of the corporation to the Consolidated Feed & Grain Company, Inc. C. B. Seay is president of the corporation and E. W. Mitchell is secretary.

Boland & Cornelius, Inc., of Buffalo, have been appointed managers for the new fleet of grain carriers put into service between the Canadian Head of the Lakes and Buffalo by the Eastern Steamship Corporation of Buffalo, whose officers are the officials of the Eastern Grain, Mill & Elevator Corporation of Buffalo, operating the Concrete-Central Elevators.

William E. Kreiner has filed plans for the immediate erection of a concrete grain elevator in Elk street near Van Rensselaer street to cost approximately \$30,000.

NEW YORK

C. K. TRAFTON - CORRESPONDENT

MEMBERS of the local feed and grain trades were much gratified this month to hear of new and novel developments regarding the Barge Canal. It was said that Acting Mayor Hulbert of this city had received from Mayor Snively of Duluth a tube of butter and a barrel of flour, part of a shipment of food products brought here by the motor-ship *Twin Ports* through the canal. It was alleged to be the first unbroken water shipment from Duluth. The steamer is a new type, constructed wholly for canal service, and has a capacity of 2,600 tons. It had a cargo of 1,250 tons of butter, eggs and flour. According to the newspaper accounts, Mr. Hulbert had made the statement that the Barge Canal must be further deepened in order to facilitate the passage of other boats of this type which would probably lead to larger shipments of a similar nature from the Northwest, which would enable New Yorkers to get butter and flour from Minnesota at half the present cost. Of course, this was such an absurd exaggeration as to the saving in cost that it was the natural assumption that Mr. Hulbert had been misquoted.

Among the noteworthy grain men elected this month to membership in the New York Produce Exchange were James A. Sweet and Gustav Loren, who are connected with the well-known grain receiving and exporting house of Robinson & Sweet. Mr. Sweet is a younger brother of Wm. L. Sweet, Jr., of the firm.

Other applicants elected to membership in the Produce Exchange were: Reed Jones of the Fisher Flouring Mills Company, Inc., Seattle, Wash.; Henry B. Clarke, grain dealer, and Edward E. B. Adams of E. F. Hutton & Co., commission merchants and brokers on all leading exchanges.

Another interesting development during the month was the arrival of 6,000 bags of gluten feed from London. It was asserted that this feed had been shipped back because of the scarcity and high prices here.

John F. Barrett, an old and well-known grain trader on the Chicago Board of Trade, spent several days late in October with his many friends on the New York Produce Exchange, having come east mainly to witness the great race between Zev and Papyrus. This brought back to the minds of the "old-timers" the fact that Mr. Barrett was long known as a lover of horses. In fact, some 20 years ago he had a string of fast horses and it is interesting to note that his

trainer at that time was Sam Hildreth, who was the trainer of Zev. During Mr. Barrett's visit it came to light that he had gone out of the firm of E. Lowitz & Co., and had decided to have a representative in this market for his own account. Hence he secured the services of C. E. Krauss, who was formerly with the Melady Grain Company. Mr. Krauss, who is a young and energetic broker, will look after the interests of John F. Barrett & Co., in this market.

The Products Agencies, Inc., of which Albert Tyck is president, has opened new offices at 44 Whitehall street, to conduct an export and import business in seeds and other commodities.

The following visitors from Chicago were among those registered on the New York Produce Exchange during October: Walter Hvale, connected with Knight & Co., grain merchants of New York and Chicago; Cromwell Jones, grain trader; M. Lee Marshall, president of the Bakery Service Corporation, and Andrew Hazelhurst, broker.

Charles A. Robinson, head of the well-known firm of Robinson & Sweet, grain receivers and exporters of the New York Produce Exchange and the Chicago Board of Trade, returned to his post on the Exchange floor early this month and was warmly welcomed by his many friends. Mr. Robinson and his wife were among those who sailed on the *Leviathan* on July 4, the first trip of the huge vessel after its rehabilitation. During their absence of four months they traveled extensively over the Continent, and especially in France, Italy and Spain, visiting numerous seaside and other resorts. While in Brussels Mrs. Robinson, who is known as "The Flag Lady," was presented to Queen Elizabeth of Belgium by Ambassador Fletcher and presented to the Queen a beautiful American flag which will be placed in the keeping of the



CHARLES A. ROBINSON

Belgian National Federation of War Wounded. To many American veterans of the late war Mrs. Robinson is known as "The Flag Lady" because of the active interest she had displayed, and especially in the formation of Antilles Post No. 146, Veterans of Foreign Wars. When sailing for Europe she was escorted to the steamer by members of this Post and a group of Boy Scouts, and received from the former a memorial wreath which she dropped overboard when the vessel had reached the spot where the "Antilles," then an American transport, was sunk by a German submarine.

Old timers in the grain, flour and feed trade regretted this month to hear of the passing away of their old associate, Henry L. Wardwell, aged 73 years. For a great many years Mr. Wardwell was a decidedly active and important figure in the market. This was especially true when he was a member of McIntyre & Wardwell. For upwards of a quarter of a century this firm occupied a particularly unique and conspicuous position in the trade, not only in this market and in Chicago, but in virtually every market of the country.

Their prominence in this market was primarily based upon the fact that they had in a few years taken the leading part in the development of speculative operations in futures and especially in wheat. It was the consensus in the trade not only here but in the West that the notoriety achieved by the firm was largely ascribed to the genius of the late Thomas A. McIntyre, who was then known as "Little Napoleon."

An announcement of considerable interest to members of the grain, hay and feed trades in other markets as well as New York was recently posted on the bulletin boards of the New York Produce Exchange, having reference to a radical change in the personnel of the Buckwheat Feed & Grain Corporation. It was announced that the following officers and directors had resigned: Henry R. Forster, vice-president; Her-

bert L. Bodman, secretary; John A. Kemp, treasurer, and F. C. Kirchoff, director. To fill the vacancies thus created the following officers and directors were elected: Harry B. Day, vice-president and treasurer; William H. Trost Jr., secretary; D. E. Evarts and Harry E. Knight, directors. Franklin L. Lewi continues as president of the corporation and it was stated that the general policies of the concern would remain unchanged.

In the opinion of experienced members of the grain and flour trade, the urgent need of foodstuffs in Germany was plainly demonstrated recently by the conspicuous enlargement in the exports of flour to Germany, whereas the clearances of wheat were only moderate. Obviously the need of food was so great that it was decided to save time by shipping flour on a materially larger scale. It was asserted that for over a month the average weekly clearances of flour to Germany were around 150,000 barrels, the bulk from New York, Montreal and New Orleans.

T. B. Hamilton, who was one of the most active and esteemed members of the local grain trade about 20 years ago, came to New York for a brief visit recently, being warmly welcomed by his many old friends on the Produce Exchange and heartily congratulated on his vigorous appearance despite his advanced age, 86 years. Years ago he handled huge quantities of grain for the Hancock Grain Company, an old Philadelphia concern. In fact, his responsibilities were so heavy that he tired out and moved to Bellefonte, Pa., where he has taken it easy, devoting a little time mainly to agricultural affairs. In explanation of his vigor and youthful appearance he stated that it was largely due to the fact that he was blessed with a wonderfully fine wife. He said that they had lived together happily for an unusually long time, 57 years, but that his wife had passed away about a year ago.

One of the most highly interesting and important features in the feed market during the past month was the decidedly novel arrival by steamer from Argentine of what was said to be the first decidedly important quantity of feedstuffs from that country since the war. Among the arrivals was 29,000 sacks of bran and 25,375 sacks of middlings, all in new 77 pound sacks; also 7,177 bags of brewers grains. The entire lot came to the firm of B. F. Schwartz & Co., Inc., well known in the feed and grain trade. It was the consensus of opinion in the market that these uncommonly large importations served to keep prices down.

MILWAUKEE

C. O. SKINROOD - CORRESPONDENT

SOME remarkable changes have taken place in the grain trade of Milwaukee as revealed by the monthly figures on the grain movement. Chief among these is the extreme scarcity of corn as shown by offerings which are almost unbelievably small for this time of the year.

The October receipts of wheat at Milwaukee were only 267,400 bushels as compared with receipts of 417,200 bushels for the corresponding month a year ago. The receipts of corn at Milwaukee for the month of October proved to be only 514,720 bushels as compared with receipts of no less than 1,740,520 bushels for the corresponding month of last year. The decline in corn receipts exceeds 1,200,000 bushels in a single month. The receipts of oats for the month of October at Milwaukee showed an extraordinary total of 5,073,800 bushels as compared with receipts of 2,299,545 bushels for the corresponding month last year. The gain in oats marketing was more than 2,700,000 bushels. The loss in corn marketing is therefore much more than made up by the gains in receipts of oats. The receipts of barley for the month of October were 1,186,580 bushels as compared with receipts of 1,123,330 bushels for the corresponding month of last year. The receipts of rye at Milwaukee for October were only 164,200 bushels as compared with receipts of 326,865 bushels for the corresponding month of last year.

This comparison shows the most irregular condition in grain receipts with oats leading the field with offerings of more than 5,000,000 bushels and with a gain over last year's supply of no less than 120 per cent. The second high grain from the standpoint of volume of receipts at Milwaukee is barley with a gain in supply of about 5 per cent. Oats and barley are the only two grains to show larger receipts than last year. From the standpoint of losses in marketing, corn heads the list with a loss for the past month of more than 1,000,000 bushels and a percentage decline of no less than 70 per cent when set alongside of the offerings last year for the same month. Rye had a decline in receipts for the past month of about 50 per cent and wheat declined in receipts between 50 and 60 per cent.

Taking the total of receipts of the five principal

grains for the past month, the aggregate is 7,206,700 bushels as compared with receipts of 5,907,510 bushels for the corresponding month of last year. The net gain in receipts of the five principal grains was 1,299,190 bushels, or approximately 22 per cent. Hence the tremendous loss in corn marketing is more than made up by the heavy receipts of oats.

Turning to the side of shipments, the figure for wheat was 209,179 bushels for the past month as compared with shipments of 197,785 bushels for the corresponding month of last year.

The shipments of corn for the past month were 410,729 bushels as compared with shipments of 1,820,935 bushels for the corresponding month of last year. The decline in corn shipments corresponds to the large decline in the receipts of corn, the loss in shipments being no less than 1,400,000 bushels in round numbers. The shipments of oats for the past month were 2,894,000 bushels as compared with shipments of 1,720,995 bushels for the corresponding month of last year. Oats shipments increased only a little more than 1,000,000 bushels, while the oats receipts gained more than 2,700,000 bushels. The shipments of barley for the past month were 341,180 bushels as compared with shipments of 349,990 bushels for the corresponding month of last year. The shipments of rye were 100,465 bushels as compared with shipments of 186,590 bushels for the corresponding month of last year.

The big gain in grain shipments was that of 1,000,000 bushels or more of oats and the big loss was in corn with a decline of 1,400,000 bushels. Total shipments for the past month were 3,955,000 bushels as compared with shipments of 4,276,000 bushels for the corresponding month of last year. The decline in shipments totalled 320,000 bushels, compared with a gain in receipts of almost 1,300,000 bushels.

The receipts of hay at Milwaukee for the past month were 1,764 tons as compared with receipts of 1,584 tons for the corresponding month a year ago. The shipments of hay for the past month were 480 tons as compared with shipments of 1,464 tons for the same month of last year. Hay shipments therefore declined almost 1,000 tons for the month, while receipts showed small gains.

October, 1923 was a big month for the flour movement in Milwaukee with 351,040 barrels as compared with receipts of 306,390 barrels for the corresponding month of last year. The flour receipts were about 44,000 barrels above those of last year. The shipments of flour from Milwaukee for the past month were only 56,660 barrels as compared with shipments of 162,130 barrels for the corresponding month of last year. Flour shipments were only about one-third of those of last year.

The receipts of feed for the past month at Milwaukee were no less than 113,000 tons as compared with receipts of only 11,540 tons for the corresponding month a year ago. Receipts of feed were approximately 10 times as large as last year for the same period. The shipments of feed from Milwaukee for the past month were 7,954 tons as compared with shipments of 20,583 tons for the corresponding month of last year. Feed shipments from Milwaukee for October, 1923, were only about one-third of the volume of last year.

The receipts of malt at Milwaukee for the past month were 36,600 bushels as compared with receipts of 64,400 bushels for the corresponding month of last year and are therefore down to about half of those of last year. Malt shipments also declined 100,000 bushels with a total for the past month of 344,600 bushels compared with shipments of 444,500 bushels for the corresponding month a year ago. Malt shipments are the real trade indicator as representing the local manufacture. As a rule malt receipts are light because the manufacturing is in this city.

The cash grain prices at Milwaukee are now frequently below those of a year ago in contrast to the showing of last month when practically all the grains reflected an advance over 1922. No. 3 barley has been quoted recently at 63 to 73 cents a bushel as compared with ruling prices of 61 to 70 cents for the corresponding time a year ago. No. 3 White oats is quoted at this time at 42 to 43 cents as compared with a quotation of 43 to 44 cents at the corresponding time a year ago. No. 2 rye has been quoted recently at 70 cents a bushel as compared with ruling quotations of 85 cents a bushel for the corresponding date a year ago. No. 2 Yellow corn has been ruling at 99 cents a bushel as compared with a quotation of 71 to 72 cents a bushel for the corresponding time last year. No. 1 Northern wheat has been selling recently at \$1.16 to \$1.25 a bushel as compared with a ruling quotation of \$1.28 to \$1.32 for the corresponding date a year ago.

Summarizing, corn leads all the grains for advances at the Milwaukee market, the present prices being about 37 per cent above those last year. Next in line with gains comes barley with an advance of 4 per cent over last year. Rye leads all the grains for large declines with a loss of approximately 17 per cent in prices since last year for the same date. Wheat is second in declines with a loss of about 5 per cent from last year's prices. Third in losses

comes oats with a decline of 2 per cent from the quotations of last year. Two gains and three losses in grain prices compare with general price gains in all the grains 30 days ago.

Grain dealers assert that the big loss in corn marketing as reflected in small receipts at Milwaukee is a nation wide condition which affects all the markets in almost the same proportion. They declare that there is not enough corn in the country to meet the actual needs, while the high corn prices, even for the new crop, fail to bring out the grain in anything like normal supply. As for the new crop of corn, the trade believes that the yields are large and that if anything like a normal marketing takes place, the price is not likely to hover for long near the dollar mark, which is almost a war price.

Milwaukee is on the itinerary of the propagandist sent out by the American Wheat Council, who will make a trip around the circle of large cities to encourage people to eat more toast. This is a part of the movement to increase American consumption of wheat. However, local grain men believe that any toast campaign cannot have any more than a minor effect on the market and that cutting of wheat production is the only lasting force which can serve to permanently maintain wheat quotations at a high level.

Grain in store at Milwaukee reflects the very heavy receipts of oats for the last few weeks and the very light receipts of corn. The storage, as reported early in the month of November, was 456,000 bushels of wheat, 24,000 bushels of corn, no less than 1,581,000 bushels of oats, 252,000 bushels of barley and approximately 296,000 bushels of rye. The supply of corn is almost negligible, the supply of oats is large and the stores of wheat, barley and rye are also fairly liberal, as would be expected at this time of the year when grain marketing is usually at the maximum.

Milwaukee milling output is lacking in special feature with production for the past week of 4,500 barrels compared with 4,000 barrels in the previous week and 6,500 barrels for the corresponding week a year ago. Production is almost 50 per cent less than for the same season last year.

Milwaukee stocks of flour have increased considerably with supply at the opening of the month at 50,000 barrels in round numbers as compared with approximately 25,000 barrels a month ago. The supply has been doubled in the last 30 days. The supply of flour on hand a year ago for the same date was 53,000 barrels, and two years ago it was 46,000 barrels. The usual flour store at the opening of November is 46,000 to 53,000 barrels, so that the present total of 50,000 barrels is close to the normal average for that season.

The farmers of Wisconsin are in many cases fighting the high price of mill feeds, although this opposition has apparently had no effect whatever in keeping the prices down. More than 1,400 farmers of Waukesha County, the center of the big dairy industry, voted at a meeting held at Delafield to stop the purchase of bran and to use substitute feeds until the price is brought down. The present bran price of \$33 a ton, they declare is unreasonable. The meeting was held under the auspices of the Waukesha County Farm Bureau, the Waukesha branch of the national organization. O. H. Cooley, the county secretary, was instructed to write to the national secretary in order to try to stir up farm bureaus in all parts of the United States. In that way it is hoped to make a national fight on the high price of bran and other mill stuffs. Secretaries of the bureaus in all counties of Wisconsin will also be asked to take action. "With wheat at \$1.07 a bushel, bran ought not to bring more than \$16 a ton, not \$33 a ton," declared Mr. Cooley. "The farmers should all stop the use of bran at this outrageous price and use such substitutes as ground oats and the like until the prices are brought down to a reasonable level."

Other meetings have been held in other parts of the state to protest at the high ruling prices for bran, but so far as can be observed the fight has not had the slightest effect on the condition of the market. Prices are still close to the recent high point.

The November rate of interest has been fixed by the Finance Committee of the Chamber of Commerce at Milwaukee at 6½ per cent. This is the same as the rate which has prevailed for many months, indicating a stable money market.

The Milwaukee Chamber of Commerce named H. M. Stratton, Walter Stern, William O. Goodrich, Hugo Stolley and W. J. Fitzgerald as the delegates to the Great Lakes Harbor Conference which was held in Milwaukee in the latter part of last month.

The Milwaukee Chamber of Commerce, through the manager of the Transportation Department, J. L. Bowlus, has taken an active part in the fight for lower grain freights as represented in the complaint filed with the Interstate Commerce Commission by the Des Moines Grain Exchange. The Des Moines grain men are trying to get lower freights to Texas points, according to Mr. Bowlus. Des Moines asks specifically

for a decrease in freight rates of 9½ to 10 cents per hundredweight to Texas points. If this cut should be granted, Mr. Bowlus explains, they would have an advantage over the Milwaukee market of 6 to 8 cents per hundred pounds. Mr. Bowlus went to Des Moines to take part in the fight and Milwaukee grain men are confident that no such rate preference will be granted by the Commission. However, they plan to fight the case to the finish to make sure that Milwaukee is not the subject of any rate discrimination.

The directors of the Milwaukee Chamber of Commerce have voted to place Walter Kasten, the first vice president of the First Wisconsin National bank, on the board as a trustee of the Chamber of Commerce gratuity fund. He will succeed Fred Vogel, Jr., who has resigned. The other trustees of the fund are Edwin S. Mack, chairman, assisted by John H. Puelicher, former president of the American Bankers Association, Albert C. Elser and Milton Baer. The gratuity fund is in the nature of a death benefit for grain men. Since 1880 a total of \$220,000 has been paid to the widows and heirs of deceased members. The highest sum ever paid was \$696 and the lowest \$288; last year \$552 was paid. The amount paid to beneficiaries is determined by taking the net income for the last year and divide it by the average number of deaths annually for the preceding 10 years. There are 206 members of the Chamber of Commerce eligible to share in this fund. A plan is now being worked out by which all beneficiaries will get \$750 each on proof of death. The full faith of the Chamber of Commerce would be pledged to such payment in case the new plan is adopted.

T. J. Durnin, secretary of the Central Investment Company, has assured W. D. Harper, the city building inspector, that balcony stairway fire escapes on the Chamber of Commerce Building and the adjoining Mitchell Building will be provided promptly. Mr. Harper threatened to close every office in the building above the second floor if this safety action was not taken. The investment company took care of the job promptly so that the entire matter has now been adjusted.

The last monthly report of the Chicago, Milwaukee & St. Paul Railroad, as received in Milwaukee, shows total loading of cars for the month in excess of 198,000 car loads, a gain of approximately 19,400 cars over the corresponding month of last year. The grain loadings are still rather light as the gain for the month was only trifling, the actual advance being one-half of one per cent. Flour and mill products loaded, however, gained 15 per cent.

The grain traffic is small as livestock shipments gained 40 per cent, coal shipments went up 4 per cent for the month, lumber went up 30 per cent, brick, stone, etc., went up 20 per cent and the miscellaneous shipments advanced 78 per cent. Hence, the increase in grain shipments of less than 1 per cent was very small.

President H. E. Byram, of the Chicago, Milwaukee & St. Paul road, said that the grain movement is now increasing and is running in November ahead of the totals of a year ago. He declared that the holding back of grain was not as noticeable as it was earlier in the fall season. Mr. Byram explains that there is a very large crop of corn and as yet very small fractions of it have been moved. He also asserts that there is still considerable grain left to be moved although most of the wheat has been shipped, he adds, so that any cut in freight rates on wheat now could benefit the farmer but very little.

Corrected crop returns for Wisconsin show that the state oats yield for 1923 was only 37 bushels to the acre, or 4 bushels less than the average of last year which was over 41 bushels. The present yield is about .1 bushel below the five-year average. The total yield of oats for the state was over 94,000,000 bushels.

The barley yield of Wisconsin for 1923 was 28.8 bushels, or 3 bushels less than last year and 1 bushel less than the five-year average. The total crop for this year is estimated at 13,000,000 bushels, or about 6 per cent below last year's output.

Several hundred Canadian and American delegates attended the Great Lakes Harbor Association conference held in Milwaukee. It was decided that the conference should cover the great basin from the western tip of Lake Superior to the mouth of the St. Lawrence River. The constitution was adopted and all sessions were held in the council chamber of the city hall.

William George Bruce, the president of the Milwaukee Board of Harbor Commissioners, was chosen president and five vice presidents were chosen in the following order: Mayor C. A. Maguire of Toronto, Mayor H. M. Hallett of Ludington, Mich., E. H. Baker, publisher of the Cleveland *Plain Dealer*, D. H. White of Midland, Ont., and C. E. Boyd of Detroit. Herman Bleyer, secretary of the Milwaukee Harbor Commission, was chosen as the secretary-treasurer of the organization.

The constitution outlines in some detail the work which the conference plans to do. The Association is pledged to the development of the Great Lakes harbors, to keep up lake levels and to prevent the

illegal diversion of water by the Drainage Canal. It is also pledged to the furtherance of waterway projects designed to connect the Great Lakes with the Atlantic Ocean. It will gather and disseminate information on commerce and port development. It is also pledged to educate the people of the United States and Canada in the potentialities of Great Lakes commerce and the importance of a direct outlet from the Middle West to the big markets of the world. It is also pledged to the increasing efficiency of Great Lakes port facilities and to the better co-ordination of railway and water transportation.

Elias Rindskopf, who has been a member of the Chamber of Commerce since 1873, 50 years ago, is dead. He had not been active in business for some time.

H. M. Stratton, prominent grain man of Milwaukee and former president of the Chamber of Commerce, was re-elected a director of the Grain Dealers National Association which recently met at Des Moines. Otto R. Sickert, feed dealer of Milwaukee, has been chosen a director of the United States Feed Distributors Association.

PHILADELPHIA

T. A. SIEBER - CORRESPONDENT

ACCORDING to the monthly statistical report of the Commercial Exchange, the stocks of grain in public warehouses in Philadelphia on November 1 were: 1,219,249 bushels wheat, 9,018 bushels corn, 175,411 bushels oats, 57,301 bushels rye and 1,666 bushels barley, compared with 869,457 bushels wheat, 20,757 bushels corn, 269,072 bushels oats, 55,057 bushels rye and 4,667 bushels barley on October 1, and 2,060,127 bushels wheat, 316,607 bushels corn, 257,017 bushels oats, 13,470 bushels rye and 1,391 bushels barley on November 1, 1922. Receipts of grain at Philadelphia during the month of October, 1923, were 2,377,396 bushels wheat, 20,339 bushels corn, 201,877 bushels oats, 10,738 bushels rye and 3,141 bushels barley. Exports from the port during the month of October, 1923, were 2,040,288 bushels wheat.

New memberships in the Commercial Exchange have been petitioned for during the past month by H. L. Freedman, flour merchant, and Murphy, Cook & Co., stevedores, both of the Bourse Building.

Albert Bussenius, of the grain and feed firm of Walton Bros., has returned from a visit with his mother and brother at Grand Canyon, Ariz.

Jacob Trinley & Son suffered a loss of \$50,000 when their feed mill and fertilizer plant at Linfield, Pa., was recently destroyed by fire.

There was 63,800 bushels of wheat taken by barge from this port to New York during the past month.

W. George Coleman, feed merchant, Bourse Building, and F. J. Barndt & Co., grain and mill feed merchants, Lansdale, Pa., have been elected to membership in the Commercial Exchange.

Having resided at Ocean City, N. J., a summer resort, during the hot months, Harvey C., Morris F. and Roy L. Miller, of L. F. Miller & Sons, grain and feed merchants, have returned to this city.

Visitors from the Northwest at the Commercial Exchange in the Bourse during the past month were: W. C. Benckert, export manager, Armour Grain Company, Chicago, Ill.; H. J. Hall, of the Sterling Grain Company, and Rudolph Opsahl, of the firm of the Opsahl & Fleming Company, feed jobbers, both of Minneapolis, Minn.

Wm. M. Richardson, of the grain and feed firm of Richardson Bros. and president of the Philadelphia Export Company, has returned to his office in the Bourse from a tour of Europe, having left about six months ago.

The Newville Warehouse Company has completed the erection of a grain elevator at Newville, Pa., which is 87 feet high and will have a capacity of 20,000 bushels. The train floor is level with the third floor of the warehouse, making possible the unloading of all grain and feed by gravity.

The results obtained in 13 variety tests conducted on farms in various parts of the state by the agricultural extension department at the Pennsylvania State College show that Pennsylvania "44" wheat, which was bred by Professor C. F. Noll, of the Experimental Station, out-yielded the other varieties by about five bushels per acre. This bears out the results obtained in the last four years, which have always favored the new wheat. Yields of 30 or more bushels per acre were reported very frequently to the State College, compared to the state average of less than 20. The increase in the

amount of Pennsylvania "44" grown in the state has been phenomenal. Last year there were over 50,000 acres harvested, and it is estimated that over 100,000 acres were grown in 1923. The extra yield obtained over Leap's Prolific, Fulcaster, Harvest King and other varieties has influenced many farmers to change to Pennsylvania "44."

Edward Molnar, general manager of the American Milling Company, Peoria, Ill.; J. G. Thomas, of the Thomas, Boyce Feed Company, Attica, N. Y., and H. J. Walter, of the J. A. Walter Milling Company, Buffalo, N. Y., visited the Philadelphia market during the past month.

The Pennsylvania embargo which was placed on all shipments of hay and straw from all points, account of accumulation, consigned, reconsigned or intended for all consignees at Merchants Warehouse, Kensington, Philadelphia, Pa., has been cancelled.

J. B. (Ben) Gould, general manager of the Hazleton Baking Company, Hazleton, Pa., died at his home there October 14 from a stroke of apoplexy. Mr. Gould was a prominent flour merchant on the Philadelphia Bourse several years ago.

According to the crop report of the Department of Agriculture, the condition of corn in Pennsylvania on November 1 was 79 per cent normal, showing a yield of 40 bushels per acre, compared with a 10-year average of 42.2 bushels, and a production of 61,040,000 bushels, compared with a 5-year average of 68,237,000 bushels.

Waldo O. Fehling, manager of the feed department of Samuel Bell & Sons, and newly elected president of the United States Feed Distributors Association, together with Charles A. Kimmack, Philadelphia representative of the Charles A. Krause Milling Company, were duck hunting at Fenwick Island, Md., about two weeks ago.

Those interested in doing business with other countries will no doubt be glad to communicate with the Philadelphia Commercial Museum, 34th and Spruce streets, Philadelphia, Pa., in answer to inquiries received by them. In reply please mention the number of item:

41386, Belize, British Honduras. "I will thank you to have the manufacturers of flour to communicate with me." Correspond in English.

41387, Prague-Karlin, Czechoslovakia. "We use this opportunity to ask you whether it would be possible for you to kindly put us in touch with American flour mills and grain exporters." Correspond in English.

41389, Antwerp, Belgium. "We should be very much obliged to you if you could bring us in relation with good grain firms." Correspond in English.

Henry Garvin, who for the past 20 years has been superintendent of the Twentieth Street Elevator of the Philadelphia Grain Elevator Company, died at his home in this city after a short illness. He was 72 years of age and is survived by his widow, three sons and six daughters.

Among the visitors at the Commercial Exchange from the Southwest were F. V. Potts, representing the Pratt Mills, Pratt, Kan.; Eugene P. Mitchell, district sales manager of the Washburn Crosby Company at Kansas City, and A. W. Witt, president of the Domestic Milling Company, Kansas City, Mo.

Embargo No. E-154, which was placed account of accumulation on all shipments of hay and straw from all points, consigned, reconsigned or intended for all consignees at 30th and Market and 31st and Chestnut streets, including Merchants Warehouse, 31st and Chestnut streets, Philadelphia, has been cancelled.

George C. Watson, aged 61 years, died at his home in Lansdowne, Pa., last week. Mr. Watson came to this country from Aberdeenshire when a young man and for the past 30 years conducted a seed business in Philadelphia.

The number of cars unloaded during the month of October, 1923, at the Girard Point Elevator, was 428 wheat; at the Port Richmond Elevator, 1,216 wheat and 28 oats; at the Twentieth Street Elevator, 7 corn, 34 oats, 5 rye, 1 mixed grain, 1 peas, 1 kafir corn and 11 buckwheat.

The average high and low closing prices of cash grain at Philadelphia during the month of October, 1923, were as follows: Wheat, No. 2 Red, for export, \$1.05½ to \$1.12; Corn, No. 2 Mixed, for export, nominal; No. 2 Yellow, for domestic, \$1.11 to \$1.31; Oats, No. 2 White, natural, for domestic, 52 cents to 53½ cents.

The second golf tournament, held by 24 members of the Commercial Exchange and others, at the Whitemarsh Country Club grounds, was won by David McMullin, Jr., feed merchant, who had a low net score of 82 and will hold the silver loving cup until the next winner. Irvin Collins had a low gross of 98.

ARGENTINE wheat production this year is forecast at 248,752,000 bushels as compared with 189,046,000 bushels last year. The rye crop, 3,701,000 bushels is over twice that of 1922. Oats forecast is 58,560,000 and barley 4,593,000 bushels.

CINCINNATI

HARRY A. KENNY - CORRESPONDENT

WITH the exception of shelled corn, receipts of grain and hay in Cincinnati during October were considerably larger than for the same month last year, and September, 1923. Wheat showed an increase of 282 cars over October, 1922, receipts for the month totalling 558 cars. Oats showed an increase of 116 cars; ear corn, 45 cars; barley, 5 cars; rye, 1 car, and feeds, 30 cars. Shelled corn receipts were 110 cars less than the total for October, 1922. Hay receipts for the month totalled 463 cars, an increase of 96 cars, over the same month last year.

According to D. J. Schuh, executive secretary of the Cincinnati Grain & Hay Exchange, receipts of wheat for the first 10 months of this year show an increase of 1,302 cars as compared with the same period for 1922. Receipts of oats also show an increase of 866 cars for the same period.

During the past month, the grain and hay business has been quite active. Dealers reported a good demand for corn and oats from the East, while millfeeds sales have increased considerably in volume over September. Wheat sales, while not large, were quite satisfactory for this time of the year.

Creation of a hay claims department was approved by members of the Cincinnati Grain and Hay Exchange at a meeting last month. Through this department, which will be organized under the jurisdiction of the Board of Directors, all shortage claims of members on hay will be handled.

A proposal to assess a fee on members, as well as non-members for the use of the weighing and inspection department in the settlement of controversies was adopted. Heretofore, only non-members were charged, when the committee ruled against them.

The Federal Products Company has purchased the plant of the New Orleans Industrial Alcohol Company, located at Westwego, La., on the Mississippi River. George F. Dieterle, president of the Cincinnati concern, in making the announcement, said that the acquisition of the New Orleans plant would in no way affect operations of the local plant at Carthage, which will continue to manufacture grain alcohol and finer grade spirits. Edward H. Brinkman, vice-president of the Federal Products Company, will be manager of the New Orleans plant.

H. Lee Early, president of the Early & Daniel Company, one of the largest grain, hay and feed concerns in the Middle West, is ill at Christ Hospital. Mr. Early, who is suffering from internal trouble, was removed from his home in Saylor Park to the hospital November 2.

Homer Chisman, official grain inspector of the Chamber of Commerce for more than 20 years, died at his home at the age of 91 last month. Mr. Chisman was highly respected by members of the grain trade, who mourn his decease.

D. J. Schuh, executive secretary of the Cincinnati Grain & Hay Exchange, represented that organization at the annual meeting of the Ohio Grain Dealers Association at Columbus, Ohio, November 2.

The 1924 convention of the Grain Dealers National Association will be held in Cincinnati, according to D. J. Schuh, secretary of the Cincinnati Grain & Hay Exchange. More than 1,000 receivers, shippers and dealers of grain from all parts of the country will attend the gathering, which will be held from September 22 to 24. Charles Quinn, secretary of the National Association, visited Cincinnati last month to report to the directors the facilities for handling the convention here. The sessions will be held at the Hotel Gibson. The Cincinnati Grain & Hay Exchange will have charge of the program for the entertainment of the visitors. John DeMolet, president, will announce the appointment shortly of several committees to have charge of the convention.

W. L. Brown & Co., hay receivers and shippers, have moved their offices from the Gerke Building on East Sixth street, to larger quarters in the Thoms Building, Fifth and Main streets.

The Early & Daniel Company has started operation at its Louisville, Ky., grain elevator, which it recently purchased from the Fleischmann interests. The plant has been remodeled and some new equipment for the manufacturing of feeds installed.

Stockholders of the A. C. Gale Grain Company held a meeting in the offices of Attorney John C. Hermann in the Provident Bank Building, November 7, and voted to dissolve the company and surrender its charter to the Secretary of State. Several months ago the grain company was absorbed by the Early & Daniel Company.

GRAIN NEWS FROM BOSTON

BY L. C. BREED

President Howard Coonley, Secretary James A. McKibbin, together with some of the members of the Chamber, recently took a birdseye view of the city as guests of the 101st Observation Squadron, M. N. G. This novel air experience was voted to be far ahead of anything that automobiles can offer. Aviation has undoubtedly gained many new fans as the result of the courtesy of the National Guard officers, and the members now feel a sort of proprietary interest in the new Airport.

The Chamber recently went on record on the railroad policy for New England, and recommended that this organization should urge the Interstate Commerce Commission to adopt a plan for the consolidation into one New England system, of all New England railroads except the Boston & Albany and Grand Trunk System lines.

The steel work of the new 14-story home of the Chamber is in position and the stone work is in place as far as the second story.

George Lyman Stratton, a prominent retired business man of Concord, N. H., died recently at his home in Lexington in his eighty-fifth year. As a young man, he was in the flour business in Boston and later went to Concord, N. H. In the vicinity of that city, he was in active business for nearly 50 years. He was the president of Stratton & Co., which company operated a flour mill and dealt in grain and feed. His wife survives him, as does a daughter.

Rowland B. French, for 50 years in the flour business in Boston, recently died at his home in Wakefield, Mass. He started in business with his father, George W. French, at the age of 16 years. Later, he helped form the firm of Noyes, French & Fickett. For the last 23 years he was a member of the firm of A. H. Brown & Bros. He is survived by his wife, his brother and two sisters.

As usual at the end of the crop year, corn along back was somewhat scarce and high. The prices on coarse grains have recently receded and receipts are larger. At the high level which has prevailed for some time past, feed and flour mill by-products were not freely purchased by farmers and dairymen. Prices, however, have recently eased off and the demand has improved. Open and moderate weather now prevailing tends to cause buyers to postpone stocking up. Receipts are not large but are likely to increase in the near future.

At Boston, general firmness prevails in hay and this is reported to be the case in other markets. Receipts are moderate and there is a good inquiry for the better grades. Rye straw is firmer with a moderate demand.

Among the visitors to the Chamber during the month of October were the following: M. P. Riley, Buffalo, N. Y.; A. D. Sears, Chicago, Ill.; C. R. Anderson, Minneapolis, Minn.; S. J. Thompson, Cincinnati, Ohio; Benjamin B. Sheffield, Minneapolis, Minn.; James Richardson, Winnipeg, Canada; R. Opsal, Minneapolis, Minn.; H. P. Russell, Chicago, Ill.; Harry J. Hall, Minneapolis, Minn.; Fred D. Seaver, New York City; F. V. Potts, Pratt, Kan.; H. M. Stratton, Milwaukee, Wis.; Reed Jones, New York City; W. B. Joyce, Duluth, Minn.; F. Benz, St. Paul, Minn.; M. E. Grant, Minneapolis, Minn.; C. S. Chace, Salina, Kan.; Walter M. Brown, Memphis, Tenn.; N. E. Flint, Moira, N. Y.; Alan D. Drake, Oswego, N. Y.; J. C. Moats, St. Joseph, Mo.; J. L. Frederick, Chicago, Ill.

Receipts of grain and feed at Boston during the month of October were as follows: Wheat, 570,675 bushels; corn, 21,100 bushels; oats, 149,275 bushels; rye, 336,000 bushels; barley, 1,800 bushels; mill feed, 154 tons; cornmeal, 1,315 barrels; oatmeal, 4,200 barrels; ditto packs, 2,000.

NEWS FROM NORTHERN OHIO

BY T. J. CUNNINGHAM

The elevator of Walter C. Hill at Rice, Ohio, is being enlarged.

A. B. Smith, for several years manager of the Farmers Exchange Company elevator at Ada, Ohio, has resigned.

Clarence Brown, owner of the elevator at Lykens, Ohio, greeted customers with an extra air of importance on the morning of November 3, due to the arrival of a baby boy at his house. Clarence now holds an ace and a pair of queens.

Congressman James T. Begg of Ohio, when asked by reporters, "What about the farm situation in Ohio, and what do the Ohio farmers want Congress to do?" is quoted as saying: "I have lived more than half my life on a farm and my people are all farmers, and I have followed the situation closely. I believe I

know what I am talking about when I say that the farmers of Ohio are making a rapid recovery and do not want any experimental national legislation, such as the price fixing of wheat."

The partnership of Einsel & Brown, owning elevators at Bloomville and Lykens, has been dissolved. L. B. Einsel now owns the entire interest in the Bloomville elevator, while C. C. Brown becomes sole owner of the Lykens elevator. Both houses will be operated as formerly by the Sneath-Cunningham Company, Tiffin, Ohio.

Hog cholera is reported to have broken out in four townships—Allen, Clay, Erie and Carroll—in Ottawa County.

Luther C. Clark has been appointed receiver for the Hancock Co-operative Elevator & Supply Company, Findlay, Ohio, upon petition of the Buckeye Commercial Savings Bank and the American-First National Bank, which charges that the company is insolvent and unable to meet its obligations. Indebtedness of \$36,000 is alleged. The two banks had obtained cognovit judgments for \$5,000 just before the receiver was appointed.

Ottawa County is now entirely in the European corn borer quarantine area, Salem and Harris Townships, which include Oak Harbor and Elmore, having been added.

Daniel R. Risser, elevator owner, lumber mill proprietor and farmer of Vaughnsville, Ohio, who died recently, left an estate of \$71,677.98, according to inventory in probate court. Mr. Risser was unmarried. His property will be divided equally among two brothers and a sister. He left no will.

Spontaneous combustion caused a fire in the dust chamber of the Fostoria Storage & Grain Elevator Company's plant at Fostoria. It might have proved a costly blaze but for the prompt action of the local fire department. The flames were smothered with no damage to the building.

According to C. J. West, state-Federal agricultural crop statistician, grain, hay and dairy prices at the farm are higher than last month, and are definitely higher than a year ago, while livestock prices have declined since September and are decidedly lower than those of this period in 1922.

Middleton, Troy and Perrysburg Townships in Wood County are included in the area infected by the European corn borer, and have just been placed under quarantine.

The receipts of the N. C. Friedley Elevator at Carrothers were practically shut off while the Columbus-Sandusky highway was being paved past that point, but the work is completed and the elevator is now enjoying a nice run of grain.

John Miarer has resigned as president of the Sandusky County Farm Bureau, and John Kowalk, Green Creek, has been named as his successor.

Wm. Gregg & Sons have installed electric motors in their elevator at Upper Sandusky, in place of a gasoline engine which formerly furnished power.

Mandale, Ohio, reports the young wheat in that section looking fine, and owing to the good yield last harvest a larger acreage was sown this fall than usual.

The Amendt Milling Company, of Monroe, Mich., has bought the Gratz mills at Tecumseh, Mich., and will discontinue milling flour and make it a feed grinding plant and a center for shipping. Pliny Gratz, former owner of the mill, has bought a mill in Norvell, Mich. The Amendt company operates several mills in Michigan and one in Delta, Ohio. William Amendt is temporary manager of the Tecumseh mill.

A. C. Hoyt, of Fostoria, reports an average corn crop of 98.14 bushels to the acre on his farm in Wood county. H. O. Rosendale, of Bloomdale, raised 99 bushels to the acre, but none so far have reached the goal of 100 bushels to the acre, which is the object of a contest now on in Wood County.

October went on record as colder and drier than the average October during the last 38 years. The average temperature was 1.8 degrees below the average for the period, while the precipitation was .92-inch less than the average, according to Prof. T. H. Sonnedecker, Government observer at Tiffin. Lowest temperature, on the 8th and 9th, was 28.0 degrees. Total precipitation, 1.71 inches.

Ralph D. Sneath of The Sneath-Cunningham Company, Tiffin, president of the Commercial National Bank and a member of the agricultural commission of the American Bankers' Association, went to Columbus November 13 to arrange for a district meeting to consider agricultural issues. The meeting was similar to those held in all parts of the country under the direction of members of the national bankers' agricultural

commission. Its aim will be to promote the interests of farmers and arrange better co-operation between farmers and bankers. Mr. Sneath will preside at the district meeting. Plans for these meetings were made by the national committee at a recent meeting in which Mr. Sneath took a prominent part.

The first snow of the season fell November 8 in Tiffin. Last year the first snow recorded fell November 20.

According to specialists in rural economics of the State Agricultural Extension Service, most of the farmers in the southern half of Ohio who grow oats in any quantity do so at a loss. They are outside of the oats belt, whose southern line runs through central Ohio at about the latitude of Columbus, and their yields cannot naturally equal yields obtained in northern Ohio. Ohio raises in all 1,500,000 acres of oats, as against 2,500,000 acres of wheat. The average yield of oats for the three years, 1920 to 1922, was 31.4 bushels. For this same period the 33 northern Ohio counties average 33.1 bushels; the 28 central counties 30.6 bushels; and the 27 southern counties, 25.4 bushels.

Aaron N. Richards, 65, grain elevator owner, road contractor of the Pioneer Rubber Company, and former city councilman, died at Willard, Ohio, November 9. He contracted pneumonia while superintending road construction. His wife, two sons and three daughters survive.

The wheat crop throughout this whole territory is looking very good. There is no rank growth anywhere, but the plants appear to be in a very healthy condition. In nearly every section the acreage is larger than last year. Much more of the corn ground was put to wheat than had been expected. Weather conditions were very favorable, and the crop was put out in good shape. The movement of the last crop still continues to be slow, and a considerable percentage of this crop still remains in farmers' hands. There is scarcely any of this last crop, in this territory, but what will easily grade No. 2. Marion County, alone, seems to have had wheat of poor quality.

The corn crop here is very large. This is not due to unusual yields, but to a much larger acreage than usual. The quality is only moderately good, a considerable percentage being chaffy. That in the northern part of this territory is the best, the poorest being found in Marion County. Most of corn shipped, so far, has been hand-husked and "snapped" from the standing stalk, and this will, perhaps, be of a better quality than that which is to come later, as the shredding of corn has now started and this corn cannot be properly sorted. More corn will be sold to the elevators from this crop than has been the case for the last few years. Oats movement continues very light, and it is generally believed that no great quantity of this crop still remains in farmers' hands.

The Clover seed crop here was more or less of a failure, both in quantity and quality. The medium seed, especially, is of very poor quality and very light in yield. What little Timothy seed is still held by farmers is not attracted by present prices, and very little is being received at the moment. The quality, however, is very good.

MINOR MENTION

SINCE Russia has been getting back into the trade, rye is the houn' dog among the grains.

THE International Grain and Hay Show at Chicago, which begins December 1, will have the sharpest competition and the best educational exhibits that have been shown.

THE American Farm Bureau Federation is not satisfied with the refusal of the railroads to lower rates for export grain, but will press their case before the Interstate Commerce Commission.

EXPERIMENTS in Minnesota indicate that bearded varieties of wheat and barley yield better and form better kernels than the smooth or awnless varieties. Grow beards and you will be happy.

BY taking over the selling agency of the U. S. Grain Growers, the American Wheat Growers, Inc., announces that they are now in a position to handle grain on commission for unorganized farmers. Luckily the unorganized farmers will not have to pay their share of the overhead.

CROP estimates may soon be made from the air instead of from car windows and hotel lounges, according to an aviator in the Government service. He claims that photographs taken from 3,500 feet could be read at a glance by an expert, and a close estimate made of the growing condition of any crop. He does not state that rust spores, green bug, Hessian fly or chinch bug can be seen from that distance.

ASSOCIATIONS

OHIO GRAIN DEALERS MEET AT COLUMBUS

The regular fall business meeting of the Ohio Grain Dealers Association was held at Virginia Hotel, Columbus, Ohio, November 2. There was a light attendance but those who came were repaid by information on the new corn crop, its price, and movement, and the benefits that always follow the meeting together of those engaged in the same trade.

President E. T. Custenborder of Sidney in calling the convention to order said he had expected to have present Mr. Gilmore, champion corn grower of the world, who had raised 134 bushels on an acre of ground, but that he had apparently been unable to attend. He thought that a larger average yield could be obtained in Ohio, and urged the dealers present to work to that end. As 90 per cent of grain dealers were farmers he thought their influence would count in raising more corn.

A. P. Sandles, who among his other activities, promoted the first corn growing contest among farmer boys of Ohio several years ago addressed the meeting, and like a good doctor pointed out several diseased conditions in the body politic, and prescribed remedies. Farming, he said, was coming back. Agriculture was the safest and oldest business in the long run. He related that in the northern counties the farmers who sowed sugar beets knew in advance just what they would get for their crop and the same information might eventually be afforded in the case of corn and wheat. His message was in the main: be patriotic, boost Ohio, join the state association for the benefits that would accrue, and learn to realize that supply and demand with organized marketing regulated all prices of farm products.

In reporting on corn conditions, C. E. Groce, of Circleville, said they were taking in a little corn in Pickaway County. It was of 22 to 23 per cent moisture and of good quality.

J. H. Motz, of Brice, reported they had not taken in much corn, and had shipped none. A great deal of the corn was still sappy and could not be shipped safely for some time.

E. O. Teegardin, Duvall: We have not taken in any corn yet.

G. C. Cline, of Ashville: We have taken no corn. It is running 25 per cent moisture. We pay 60 cents for 70 pounds, and condition is not as good as it was two weeks ago.

Jesse Lewis, of Troy: The early frost of September caught our corn very badly. The little we have is not in good shape. Have not encouraged its movement.

S. L. Rice, Metamora: Our corn averages 25 per cent moisture. The best we have taken in runs 22 per cent. I think by next week we will have a good movement.

Mr. Pierce, of Middlepoint: There has been more than 100 cars shipped from Middlepoint already. We have a bumper crop of corn, the best I have ever seen in Van Wert County.

D. J. Schuh, Cincinnati: We have been receiving corn on our market for the past two or three weeks. It has been running about 20 to 25 per cent moisture. We had one car that lost 1,600 pounds on account of moisture. The Grain Dealers National Association has accepted the invitation of the Cincinnati Grain and Hay Exchange to hold its next annual meeting in our city on dates September 22, 23, 24, 1924. We invite you all to attend and visit our Gateway of the South.

H. G. Pollock, of Middlepoint, said that Mr. Pierce, who had spoken for Van Wert County previously, was his neighbor. He had bought corn at Middlepoint for 25 years. Had a little frost on October 25 but it did no damage. We commenced handling corn about two weeks before we should. We have been loading some corn on the Pennsylvania in the car and have found it hard sledding to move it. We have a big crop and much of it goes into consumption in Ohio. The price of corn when compared with that of hogs is too high. A feeder cannot buy this corn and feed it at a profit. Therefore, he won't buy it. We are paying in Van Wert County 80 to 90 cents per 100 pounds.

Harry Rapp, Sabina: There has been no big run of corn in our county. We find the crop is not as good as we expected as the result of a big wind storm. We are counting on about two-thirds of what we estimated. It is averaging about 22 per cent moisture.

H. G. Dehring, Genoa: We started taking in corn last Monday paying 90 cents per 100 pounds. Our corn is in good condition. Ranging from 26 to 27 per cent moisture.

C. J. West, state crop statistician, reported that he didn't think there was much change in the wheat

acreage over the state with prices running about the same as last year. He didn't think that farmers were complaining as much as the politicians would have one believe. There were 10 per cent more hogs to feed this year than last year.

Mr. Dehring also spoke briefly on the subject of the farmer. As he summed up the situation the farmer had been filled by politicians with the idea that he was the most abused man on earth. If the farmer would farm only what he could take care of himself he would make money. He said he was promoting the growth of Alfalfa hay for grinding into feed. The growing of Alfalfa increased the productiveness of the farm.

Harry W. Fish, of Huntington, W. Va., thought the farmer was not influenced by the politicians any more than the city man. The farmer is continuing to grow wheat and he presumed he knew what he was doing.

The meeting then adjourned for luncheon.

AFTERNOON SESSION

Vice-president S. L. Rice, of Metamora, presided over the early part of the afternoon session, and President Custenborder spoke briefly on the subject of "Association Activities." He gave an invitation to those present who were not members to join the organization and share in its benefits. About 75 per cent of the troubles of the average dealer were local he said, and resulted in paying more than grain was worth, due to competition, also the dealers sold supplies for less than they were worth. "We perfected our organization in Miami territory 25 years ago, and 71 elevators joined. Farmers were at first hostile to us but since that time the farmers themselves have taken over some of these elevators and we have now no trouble with them. On the contrary they are surprised that we do business on such a small margin. There were only two failures in 20 years among these elevators, which show the value of our organization."

Concerning the Farm Bureau leaders and the Ohio Marketing law, Mr. Custenborder said he had failed to get any of these leaders and supporters of this bill to explain its merits. The Farm Bureau officials, however, made the claim that the bill was of great value to the co-operative elevators. He pointed out that Mr. Lincoln, of the Farm Bureau, had accused dealers of taking excessive margins, and said that on the contrary the dealers had invariably paid to farmers more for grain than the market warranted, and depended on advancing markets for profits, not through regular merchandising of grain.

Mr. Custenborder referred to a statement by J. W. Shorthill of Nebraska that the proper solution of marketing was a good, honest privately owned elevator run on the square. He said he would rather have farmer competition than some of the independent dealers. The farmer likes to make money as well as any one and he was willing to let the grain man handle his grain at a little profit. He stated also that the work of the Farm Bureau was originally designed to be educational and that county agents ought to be discouraged from dabbling in the affairs of the grain dealer.

Col. C. E. Groce said that Co-operative Marketing was a subject in which they were all interested. The farmers had bought an elevator in his town but it didn't seem to make much difference in their trade. The farmers did not always meet the rise in price of a competitor which showed they wanted to make some money.

Mr. Custenborder said he was a stockholder in the oldest farmer's elevator in Ohio and that he welcomed the farmer in the grain business because he thought it would result in improvement. Most of the managers had no backbone, however, and have not made the progress that they should. One of the things the farmer should do was to prepare his grain for market.

The meeting closed with a general discussion on the activities of the county agent and the opinion was expressed that his authority and duty only extended to teaching the farmers better farming methods. When he enlarged this sphere he was going beyond the objects contemplated by the government that created him. It was suggested that dealers get into closer touch with the county agents and work together for larger and better crops and improved farming conditions generally.

THE ATTENDANCE

The following signed the register presided over by C. O. Garver of Columbus: A. E. Huston, Canal Winchester; W. S. Cook, Columbus; H. L. Hockman, Canal Winchester; J. A. Myers, Pleasant Hill; J. R. North, Groveport; Rea Chenoweth, London; C. T. Lloyd, Fulton; H. W. Updike, Fredericktown; J. B. Van Wagener, London; Lester Howard,

C. A. King & Co., Toledo; George Stephenson, Rosewood; Kirley Threlkeld, Maplewood; A. M. Daugherty, Derby; F. M. Synder, Chillicothe; P. Sayles, Smith, Sayles Grain Company, Columbus; I. E. Oglesbee, R.F.D., Springfield; Earl Fristoe, Piqua; Fred Kile, Kileville; W. M. Myers, Lockbourne; J. M. Blains, Derby; E. Fauber, Swanton; H. Rapp, Sabina; Jesse Lewis, Troy; G. C. Cline, Ashville; W. F. Heffner, Circleville; Burton Cain, Outville; C. K. Patterson, Piketon; R. A. Sheets, R. S. McCague, Ltd., Pittsburgh, Pa.; E. A. Schwat, Eastern Grain, Mill and Elevator Corporation, Buffalo, N. Y.; E. A. Grubbs, E. A. Grubbs Grain Company, Greenville; A. B. Barrlock, Lexington Elevator and Mill Company, Lexington; J. H. Motz, Brice; H. G. Dehring, Genoa; R. W. Graham, Defiance; A. H. Cratty, Columbus; Omer Snyder, Columbus Grain & Hay Company, Columbus; D. E. Horn, Greenville; W. E. Hall, Ashville; D. McCrery, Urbana; H. W. Fish, Huntington, W. Va.; R. O. Strong, Cincinnati Seed Company, Cincinnati; G. R. Forester, Kasco Mills Inc., Toledo; D. M. Cash, Ohio Farm Bureau Service Company, Columbus; T. B. Schafly, Beach City; C. L. Berryhill, Fletcher; E. L. Allton, St. Paris; D. J. Schuh, Secretary, Cincinnati Grain & Hay Exchange, Cincinnati; Frank Baughman, Jackson Center; J. A. Streicker, J. F. Zahm & Co., Toledo; B. Ackerman, Lima; J. M. Pence, Jackson Center; C. E. Groce, Circleville; F. H. Tanner, Columbus; E. O. Teegardin, Duvall; J. A. Resler, Caledonia; S. L. Rice, Metamora; W. H. Persuiger, J. E. Wells & Co., Sidney; E. D. Custenborder, Custenborder & Co., Sidney; J. W. Simons, Sidney; J. M. Bell, Bauer Bros. Company, Springfield; A. W. Fulton, Xenia; C. O. Garver, J. W. McCord, Columbus; H. G. Pollock, Pollock Grain Company, Middle Point; J. W. McCord, Columbus; F. G. Winter, The Quaker Oats Company, Chicago, Ill.

INTERNATIONAL GRAIN SHOW

South Africa will display its agricultural skill at the International Grain and Hay show in Chicago the first week of December. Eight different entries of corn from Transvaal will compete with American grown corn for the high prizes at stake. News of South Africa's entry has just been received by Professor W. Q. Fitch of Purdue University, assistant superintendent of the show. E. A. Papendorf, vice-president of the South African Maize Breeders' growers and Judges' Association and seven other growers are sending samples direct to the United States Department of Agriculture where they will be sterilized to meet embargo conditions and then entered in the big Chicago show. Some of the South African corn is said to have been grown from Indiana seed.

South Africa's participation in the show, which for five years has been made possible through the \$12,000 cash prize offered by the Chicago Board of Trade, will be followed by other foreign nations. During the trip around the world, George S. Bridge of the Board of Trade, interested a number of countries that will enter the competition probably next year.

More than 5,000 samples will be entered at this year's show.

A new feature just announced is a grain judging contest by college boys. Three students from the grain and forage classes in each college will compete. Already teams have been entered from the agricultural colleges of Pennsylvania, Michigan, Iowa, Kansas, Oklahoma, North Carolina and Idaho. Professor A. C. Arny, University Farm, St. Paul, Minn., is in charge of this contest. The Chicago Board of Trade has made provision for the feature in addition to its regular \$12,000 premium list in the interest of better farming.

Hundreds of junior entries have come in from boys' and girls' clubs which now represent a membership of 700,000. The boys and girls attending the show will be given a luncheon at which Secretary of Agriculture Wallace and others will speak. The juniors will have a most comprehensive display at the grain show as well as at the International Live Stock Exposition. Fifteen hundred winners in county, state and regional contests will be sent to Chicago. Forty-six states will be represented by their champions. In the junior corn contest keenest competition will be for the title of "corn prince of the world." This honor was won last year's show by 14-year-old Glen Phares of Indiana.

Canada is sending the biggest outlay yet entered in the annual show. Educational exhibits being arranged now are from Illinois, Idaho, Minnesota, Alberta, Montana, Texas, Kansas, Wisconsin, Ohio, North Dakota, Michigan, Nebraska, Maryland and Indiana.

G. D. N. A. DECIDES 1924 DATES

Secretary Charles Quinn announces that the Board of Directors of the Grain Dealers National Association has decided upon Cincinnati, Ohio, as the meeting place for the 1924 convention of that organization. The dates selected are Monday, Tuesday and Wednesday, September 22, 23 and 24. The Hotel Gibson will be the convention headquarters on those dates.

NEW COMMITTEES FOR THE NATIONAL

President F. E. Watkins has appointed the following committees to serve the Grain Dealers National Association during the coming year:

Arbitration Appeals Committee

Elmer Hutchinson, chairman, Arlington, Ind.
H. A. Rumsey, Chicago, Ill.
W. W. Manning, Fort Worth, Texas.
Jno. S. Green, Louisville, Ky.
A. S. MacDonald, Boston, Mass.

Arbitration Committee No. 1

J. R. Murrel, Jr., chairman, Cedar Rapids, Iowa.
C. S. Rainbolt, Omaha, Neb.
O. F. Bast, Cedar Rapids, Iowa.

Arbitration Committee No. 2

Frank B. Bell, chairman, Milwaukee, Wis.
H. W. Reimann, Shelbyville, Ind.
E. H. Bingham, Cedar Rapids, Iowa.

Arbitration Committee No. 3

S. L. Rice, chairman, Metamora, Ohio.
F. A. Coles, Middletown, Conn.
Thos. C. Craft, Jr., Baltimore, Md.

Arbitration Committee No. 4

E. W. Crouch, chairman, McGregor, Texas.
E. Wilkinson, Birmingham, Ala.
Tom F. Connally, Clarendon, Texas.

Arbitration Committee No. 5

H. C. Gamage, chairman, Kansas City, Mo.
Dick O'Bannon, Sherman, Texas.
L. C. McMurtry, Pampa, Texas.

Arbitration Committee No. 6

I. C. Sanford, chairman, Portland, Ore.
W. J. McDonald, Seattle, Wash.
F. G. E. Lange, San Francisco, Calif.

Feed Arbitration Committee

J. H. Caldwell, chairman, St. Louis, Mo.
H. R. Wilbur, Jamestown, N. Y.
J. A. Canfield, Minneapolis, Minn.

Committee on Legislation

A. E. Reynolds, chairman, Crawfordsville, Ind.
E. M. Wayne, Delavan, Ill.
E. C. Eikenberry, Camden, Ohio.
J. C. Mytinger, Wichita Falls, Texas.
L. W. Forbell, New York, N. Y.

Committee on Trade Rules

C. D. Sturtevant, chairman, Omaha, Neb.
H. L. Strong, Wichita, Kan.
A. W. Goodnow, Boston, Mass.
Bert K. Smith, Fort Worth, Texas.
S. P. Mason, Sioux City, Iowa.

Committee on Transportation

Henry L. Goemann, chairman, Mansfield, Ohio.
G. Stewart Henderson, Baltimore, Md.
Geo. E. Booth, Chicago, Ill.

Committee on Merchant Marine

Julius W. Jockusch, chairman, Galveston, Texas.
Eugene Blackford, Baltimore, Md.
W. L. Richeson, New Orleans, La.

Committee on Membership

Leo Potishman, chairman, Fort Worth, Texas.
A. E. Buch, Milwaukee, Wis.
Harry Williams, Nashville, Tenn.
C. M. Horst, Hagerstown, Md.
L. N. Reasoner, Omaha, Neb.

Hay and Grain Joint Committee

Geo. S. Bridge, chairman, Chicago.
R. M. White, Duluth, Minn.
Irvin T. Fangboner, Bellevue, Ohio.

Committee on Uniform Grades

Bert Dow, chairman, Davenport, Iowa.
Jas. F. Hammers, Boston, Mass.
J. M. Rankin, Cambridge, Neb.
O. P. Hall, Greenville, Ohio.
Dan Joseph, Columbus, Ga.
G. A. Hax, Baltimore, Md.
Robert P. Quest, Denver, Colo.
Lew Hill, Indianapolis, Ind.
John E. Bishop, Houston, Texas.
Geo. H. Martin, Los Angeles, Calif.
Monroe A. Smith, Philadelphia, Pa.

Grain Products Committee

E. C. Dryer, chairman, St. Louis, Mo.
D. G. Lowell, Minneapolis, Minn.
M. F. Baringer, Philadelphia, Pa.
J. W. Jouno, Milwaukee, Wis.
S. Mowat, Detroit, Mich.

Committee on Crop Reports

G. E. Blewett, chairman, Fort Worth, Texas.
Kenton D. Keilholtz, Toledo, Ohio.
G. C. McFadden, Peoria, Ill.
E. H. Sexauer, Brookings, S. D.
Harry Miller, Olin, Iowa.
Paul Bossemeyer, Salina, Kan.
F. G. Bell, McGregor, Iowa.
A. C. Waters, San Angelo, Texas.
A. G. Smith, Wooster, Ohio.

International Relations Committee

J. J. Rammacher, chairman, Buffalo, N. Y.
N. H. Campbell, Toronto, Can.
James A. Richardson, Winnipeg, Man.
A. S. Dumont, Detroit, Mich.
H. N. Sager, Chicago, Ill.
H. J. Atwood, Duluth, Minn.

Milling and Grain Joint Committee

Richard P. Johnson, chairman, Knoxville, Tenn.
Chas. Jenkins, Noblesville, Ind.
Chas. G. Ireys, Minneapolis, Minn.
J. B. McLemore, Nashville, Tenn.
H. I. Baldwin, Decatur, Ill.

Committee on Rejected Applications

F. G. Horner, chairman, Lawrenceville, Ill.
S. C. Armstrong, Seattle, Wash.
E. H. Beer, Baltimore, Md.

HAY ASSOCIATION AT CEDAR POINT

The National Hay Association has lost no time in selecting the place of meeting for 1924. The directors have selected Cedar Point, Ohio, and the dates will be July 1, 2 and 3. This will be the 31st annual convention of the Association, and even this far ahead tentative plans are in preparation.

Secretary J. Vinning Taylor makes the following important notice on rate hearings:

"The Interstate Commerce Commission has agreed to widen the scope of its hearing in the Grain Products case (Docket 15263) to include Hay,

and have set hearings as follows: 10 a. m. November 14, 5th floor, New Kansas City Athletic Club, Kansas City, Mo.; 10 a. m., November 26, U. S. Court Room, Minneapolis; 10 a. m., December 5, U. S. Court Room, Spokane, Wash.; 10 a. m., December 11, Merchants Exchange, Room 237, San Francisco, Calif.; 10 a. m., December 17, U. S. Court Room, Phoenix, Ariz. We understand there will be subsequent hearings had in the Middle West, East and South.

"You are most earnestly requested to be present at these hearings, or at least the one nearest to you, and give testimony as a witness and member of this Association. The information we must have is: (a) Volume of hay shipped or received, with territory covered. (b) That regardless of whether the rates are reasonable or unreasonable so far as per car earnings are concerned, hay traffic is an important factor to the farming industry of this

country, and something must be done to enable raisers to ship this traffic over a wide range and ship at a price they can live on.

"These will be the two big points that we will have to bring out. Both Mr. Suttie, chairman of our Transportation Committee, and Mr. Sims, traffic manager, will be on hand but you should be there to help them. You, of course, understand that you go on your own expense but this Association has appealed to the Interstate Commerce Commission to include hay in these hearings and it was done for your good. Will you notify me at once whether or not you will be on hand? It is your duty to be there regardless of anything else. This is the most important appeal we have made in years. Now is your chance to help us put something beneficial across.

"We are co-operating fully with the Kansas City Hay Dealers Association in respect to this Docket."

TRANSPORTATION

CANADIAN GRAIN MOVING

Lake vessels moved 59,618,204 bushels of Canadian grain in October, 1923, as compared with 51,634,424 bushels in October, 1922, the Board of Grain Commissioners announced today. Owing to the late start, the Commissioners said, the increase brought the movement up to about the average of last year, although 96 United States vessels carried grain cargoes this year, as compared to 116 last year, and 233 Canadian boats were loaded with grain this year, as against 111 in 1922.

CANADIAN RATE REDUCTION

The Canadian National Railway is expected soon to reduce its grain rates from the Prairie provinces to the Pacific Coast. When this is brought about the prairies will be divided into eastern and western traffic zones with the result that Vancouver will get a much larger share of the export grain business. Fifty thousand cars of which 5,000 are new, have been assigned to the task of moving the wheat crop. Harvesters are being brought from England at a fare of \$52 from the British port to the Canadian West, with a proportionately low return fare.

GRAIN RATE INVESTIGATION

There has been set for hearing in Kansas City, November 14, before Commissioner Aitchison and two examiners, a general investigation into the rates on grain and grain products throughout the entire United States. At the same time and place, there will be a further hearing in the so-called Kansas Grain Case, Docket 14393, in which Kansas and other interests have been endeavoring to secure special decreases for the Western Group, which was denied on the present record. The general investigation as to grain rates was instituted on the Interstate Commission's own motion. The hearings are important to all grain dealers.

SENATOR CUMMINS' POSITION

Emphatic opposition to any change in section 15-A of the Transportation Act—the rate-making section of the law—was recently voiced by Senator Albert Cummins. He asserted that there was an erroneous idea prevalent that Section 15-A of the Act was responsible for high rates. He contended that the section has been a restriction upon high rates. In his opinion, he said, railroad rates would have been a great deal higher had it not been for Section 15-A. Another change in the Transportation Act favored by Senator Cummins would provide for the partial return to the states of the authority to control rate making on intrastate traffic. He expressed himself as favoring giving back to the states their control over individual rates.

GRAIN BARGES ON ILLINOIS RIVER

The Peoria Grain & Barging Company, with offices at Havana, Peoria and Beardstown, Ill., has built up a practical and extensive service for Illinois River transportation of a permanent character. A considerable grain producing acreage cut by the Illinois River, but for a large part inaccessible to railroads, was the start of the idea, justifying the erection of elevators, loading stations, the purchase of barges and tow boats and the development of a freight rate structure that has met hearty response on the part of those marketing such grain from the territory covered.

The company therefore has established a grain department which is in charge of J. A. McCreery, a practical man, member of the Peoria Board of Trade, and now operates five grain elevators and five other leading stations. Three of the elevators are of concrete construction, equipped with standard grain handling machinery, manufactured by the

Union Iron Works, Decatur, Ill., and the B. S. Constant Manufacturing Company located at Bloomington, Ill.

GRAIN RATES FOR MISSISSIPPI

A scheme of mileage rates for reshipping purposes and of percentage of the Memphis-New Orleans reshipping rate on grain has been suggested by Examiner Henry C. Keene, in a report on No. 14028, Mississippi Railroad Commission et al. vs. Alabama & Vicksburg et al., for the relief of Mississippi grain dealers. The latter complained that the reshipping rates from Memphis, Cairo and St. Louis to destinations in Mississippi were unduly preferential of the dealers at the crossings mentioned, and unreasonable from various states of origin. Mr. Keene recommended that:

The Commission should find that the proportional and reshipping rates on grain and grain products, in carloads, from reshipping points in Kansas, Nebraska, Colorado, Iowa, Minnesota, Indiana, Illinois and Missouri to points in Mississippi are and for the future will be unreasonable and unduly prejudicial to the extent that they exceed the applicable rates to Memphis, Tenn., plus the following rates for distances named beyond:

Distances	Rate Per 100 Lbs. (Cents)
50 miles and under	5
100 miles and over 50	5
150 miles and over 100	9.5
200 miles and over 150	11.5
250 miles and over 200	13
300 miles and over 250	14.5
350 miles and over 300	16
Over 350 miles	17

The Commission should further find that the rates on grain and grain products, in carloads, from interior points in Oklahoma, Kansas, Nebraska, Colorado, Iowa, Minnesota, Indiana, Illinois and Missouri to points in Mississippi are and for the future will be unreasonable and unduly prejudicial to the extent that they exceed the rates to Memphis, Tenn., by more than the rates which will be produced by applying the following percentages for the distances stated to the reshipping rate from Memphis to New Orleans:

Distances	Percentage of Memphis-New Orleans Reshipping Rate
50 miles and under	29.5
100 miles and over 50	44
150 miles and over 100	56
200 miles and over 150	67.5
250 miles and over 200	76.5
300 miles and over 250	85
350 miles and over 300	94.5
Over 350 miles	100

The Commissioner should further find that the rates on grain and grain products, in carloads, from points in Texas to points in Mississippi are and for the future will be unreasonable to the extent that they exceed the lowest combination composed of either the applicable rates to Memphis, Tenn., or the proportional rates prescribed from Texas points to Vicksburg, Miss., in Texas Grain Dealers' Assn. vs. A. & S. Ry. Co., 81 I. C. C., 96, plus the following rates for the distances named:

Distances	Rates Per 100 Lbs. (Cents)
50 miles and under	5
100 miles and over 50	7.5
150 miles and over 100	9.5
200 miles and over 150	11.5
250 miles and over 200	13
300 miles and over 250	14.5
350 miles and over 300	16
Over 350 miles	17

The Commission should further find that the maintenance of reshipping rates from Memphis without contemporaneously maintaining reshipping rates from Memphis points does not constitute undue prejudice, but that in so far as the rules, regulations and practices under which grain or its products may be stopped at Memphis for milling, storing or other transit services and later reforwarded at less than the sums of the local rates to and from Memphis, are more favorable than the rules, regulations and practices under which transit service is accorded at Mississippi points, the complainants are subjected to undue prejudice which should be promptly removed. It is understood that the carriers are engaged in a revision of the rules in force at market points, including Memphis, with a view to the establishment at the various market of more uniform rules which shall conform more nearly to the rules in force at interior points. Accordingly, no order should be entered at this time with respect to the transit situation.

**EASTERN**

William E. Kramer is to build a concrete elevator at Buffalo, N. Y., to cost \$30,000.

The Standard Mill & Elevator Company of Jersey City, N. J., is building a new house there.

The Segall Hay & Grain Company, Inc., of Baltimore, Md., has changed its name to M. B. Segall & Sons, Inc.

George H. and John A. White have purchased at Pittsfield, Mass., the Berkshire Flour & Grain Company. The consideration was \$10,000.

The Spencer Grain Company, Inc., at Waterbury, Conn., is to be managed by R. Newell, formerly in charge of the Adams Company at North Woodbury.

E. G. Beachwood is succeeded at Sherburne, N. Y., by the Sherburne Grain & Coal Company. Sidney C. Webb is president and E. G. Beachwood, treasurer and manager of the firm.

A new grain elevator of cribbed, iron-clad construction and with capacity of 20,000 bushels, has been erected at Newville, Pa., for the Newville Warehouse Company. The Spencer Construction Company of Baltimore has the contract. A coal trestle facilitates the handling of coal.

CANADA

The Tiffin Elevator at Midland, Ont., will be equipped with an addition in time for this year's crop.

P. G. Brown, superintendent of the Canadian Government Elevators at Calgary, has been transferred to Moose Jaw, Sask.

Elevator "C" of the Quaker Oats Company, located at Saskatoon, Sask., will be doubled by the addition of 82 concrete tanks.

A Randolph Grain Drier of 200 bushels' capacity has been installed at Belle River, Ont., by the Belle River Grain Company.

James Richardson & Sons are negotiating for the purchase of the Woodward Elevator now under construction at Vancouver, B. C.

The Canadian Government has let the contract for enlarging the Port Colborne Elevator. Work will be started at once and the enlarged elevator will have a capacity of 3,000,000 bushels.

Work on the elevator being erected by A. E. Woodward at Vancouver, B. C., has been discontinued. The elevator was nearing completion and would soon have been able to receive grain. Negotiations will probably be gone into with the Vancouver Harbor Board and the Government.

The Western Pacific Grain & Terminals, Ltd., has made a proposal to the City Council of New Westminster, B. C., for the establishment of a grain elevator there. The offer was to recapitalize at \$1,500,000, float a bond issue, and finance the building of a 1,500,000-bushel elevator on the waterfront of the port.

INDIANA

A preliminary certificate of dissolution has been filed by the Oaktown Grain Company of Oaktown, Ind.

The elevator at Perrysville, Ind., has been bought by Walter Moore, Billy Coffin and Clarence Wooster.

The elevator at New Waverly, Ind., is to be rebuilt at a cost of \$20,000. Burt Chester and Garrett Townsend are the owners.

A 300-bushel per hour Randolph Direct Heat Drier has been installed by the Farmers Co-operative Company at Ade (mail to Brook), Ind.

The Wallace Milling Company of Huntingburg, Ind., has equipped its house with a Wonder Grain Cleaner, made by the Weller Manufacturing Company of Chicago.

Martin Cutsinger & Co., have taken over the Cutsinger & Thompson Grain Elevator at Shelbyville, Ind. The plot of ground where the elevator stands was the site of a mill for more than 100 years.

New machinery is being installed in the elevator of the Wabash Grain Company at Sandborn, Ind., including a modern oil engine. The handling capacity of the elevator is being improved and new shellers and corn dumps are being installed.

The grain elevator at Yoder, Ind., has been bought from the heirs of the late Jacob Harber by the Studebaker Grain & Seed Company of Bluff-

ton. Possession was given October 10. The grain company owns elevators at Van Buren, Greentown, Keystone and Bluffton.

Edw. Maier, Norman Kelley, Edw. Ziegler and George Beehler have incorporated at Mishawaka, Ind., as the Mishawaka Grain & Coal Company. Its capital stock is \$36,000.

John Luzadder and Lewis McVey have bought the elevator of the Redkey Equity Exchange at Redkey, Ind. W. E. Rooker will probably continue as manager of the new firm.

Weller Improved Grain Feeders and other machinery have been installed by the Nickel Grain Company of Valparaiso, Ind. The Goodrich Construction Company made the installation.

Capitalized at \$25,000, the Wolverine Grain Corporation has been incorporated at Walkerton, Ind., to engage in wholesale grain and feed. Paul B. Bellew, Anna M. Schwartz, W. F. Kaltenbach and William E. Cassidy are interested.

THE DAKOTAS

The Farmers Elevator Company of Platte, S. D., has built a new warehouse there.

A local elevator at Colome, S. D., is to be bought by the Farmers Union of that place.

J. D. Sullivan is manager of the Alamo Farmers Elevator Company at Alamo, N. D.

The Farmers Elevator Company of Whitman, N. D., is making repairs on its elevator.

C. L. Turner is manager of the elevator of the Monarch Elevator Company at Heaton, N. D.

Improvements are being made to the elevator of the Cullen Elevator Company at Aneta, N. D.

W. F. Conway of Mitchell, S. D., is manager of the Farmers Elevator Company at Davis, S. D.

The elevator of the Spaulding Elevator Company at Fordville, N. D., has been painted and repaired.

A new truck scale and air dump have been installed by the Herreid Equity Exchange of Herreid, S. D.

Mr. McCarter is succeeded as manager of the Farmers Elevator Company at White Rock, S. D., by M. Martinson.

A. A. Harrington has resigned his position with the Farmers Elevator at Towner, N. D., and is succeeded by John Ellingson.

The Tulare Farmers Elevator Company at Tulare, S. D., has been succeeded by the recently incorporated Tulare Grain Company.

The Farmers Union Elevator Company of Fedora, S. D., has been reorganized and operations started as the Farmers Elevator Company.

The elevator of John Gieb at Bowdle, S. D., has been remodeled with a new foundation and new leg. The house has been repainted.

The elevator of L. Dornbush at Pollock, S. D., has been bought by the Olsen Grain Company. Improvements will be made next season.

The new elevator of A. Krause at McLaughlin, S. D., has been opened for business. The elevator is of 25,000 bushels' capacity and is equipped with modern handling machinery.

The following have installed Wonder Grain Cleaners, made by the Weller Manufacturing Company of Chicago: Washburn Elevator Company, Washburn, N. D.; Rice & Olson, Winfred, S. D.; Farmers Elevator Company, Howard, S. D. (second cleaner purchased).

SOUTHERN AND SOUTHWESTERN

The Gillett Grain Company is erecting a storage house at Whitewright, Texas, 21x100 feet.

A new elevator is soon to be built at Valley View, Texas, by the Whaley Mill & Elevator Company.

A warehouse 80x150 feet is to be erected at Little Rock, Ark., by the Hayes Grain & Commission Company.

A new shelling plant is being built by S. S. Kerr of Nashville, Tenn., and the old house is being covered with iron.

E. W. Stalnaker, G. W. Riddlehuber and others have incorporated at Greenwood, S. C., as the Sterling Flour & Grain Company. Its capital stock is \$20,000.

Machinery is being installed in the elevator at Decatur, Texas, formerly operated in the Southland Cotton Oil Company which was recently

bought by the Bewley Mills Company of Fort Worth. The plant will handle prepared and balanced feeds.

The Southwestern Elevator & Mercantile Company of Hardtner, Kan., has established a branch at Capron, Okla.

The contract has been let by the Mountain City Mill Company of Chattanooga, Tenn., for the erection of 32 grain storage bins.

G. H. Belcher is manager of the South Elevator of the Red Star Milling Company at Medford, Okla., succeeding the late W. E. Smith.

The Farmers Elevator Company of Marshall, Okla., has installed a Wonder Grain Cleaner, made by the Weller Manufacturing Company of Chicago.

E. C. Downman, E. A. Buhring and A. V. Wood have incorporated at Houston, Texas, as the Downman Grain & Hay Company, capitalized at \$12,000.

T. J. Taylor, F. Covin and A. D. Beck have incorporated at Marshall, Texas, as the Taylor Mill & Elevator Company, with capital stock of \$25,000.

H. O. Miller, John Simpson and William Simpson have incorporated at Guthrie, Okla., as the Oklahoma Farmers Mill & Elevator Company, capitalized at \$5,000.

The Elkton Grain & Milling Company of Elkton, Tenn., has been dissolved and assets have been taken over by T. M. Stevenson and E. E. Eslick. O. O. Coble, T. M. Stevenson, N. L. Mansfield, H. P. Wynn and E. E. Eslick were formerly interested.

A mill, warehouse and 75,000-bushel elevator are to be built at Oklahoma City, Okla., for the Harde-man-King Milling Company. The contract has been let to the Jones-Hettelsater Construction Company. The machinery will be furnished by Sprout, Waldron & Co., with output of 10 tons feed per hour and 500 barrels cornmeal per day.

ILLINOIS

Remodeling is to be done on the elevator at Le Roy, Ill.

A new dust spout has been installed in the Farmers Elevator at Beason, Ill.

The elevator of the Merna Grain Company of Merna, Ill., has been painted.

The Windsor Grain Company of Windsor, Ill., has been bought by John W. Moberley and Don Moberley.

S. J. Kredier is no longer manager of the Lewis Elevator at Prairie City, Ill. Neal Zook has succeeded him.

Mart Koenig is manager of the Farmers Co-operative Lumber, Grain & Implement Company of Port Byron, Ill.

The elevator of the Little Mackinaw Grain Company at Minier, Ill., is being repaired and the driveway is being lowered.

The Farmers Grain Company's elevator at Hoopston, Ill., has been equipped with a Union Iron Works Cleaner and Sheller.

The elevator of the Wing Grain Company at Wing, Ill., is being repaired, and equipped with new shafting, a 10-ton truck and wagon scale.

The elevator of the Horner Elevator & Mill Company of Lawrenceville, Ill., at St. Francisville, Ill., has been sold to R. J. Jessop of Vincennes.

B. L. Christy and A. B. Roberts have incorporated at Sherrard, Ill., as the Sherrard Lumber & Grain Company. Its capital stock is \$20,000.

The Pinkstaff Co-operative Elevator Company at Pinkstaff, Ill., has bought the 60,000-bushel elevator of the Horner Elevator & Mill Company.

The elevator of the Whalen Bros. at Charleston, Ill., which burned, has been rebuilt and is now equipped with Union Iron Works equipment.

The elevator of R. A. Strong at Rollo, Ill., which burned in September is being rebuilt and will be ready for operation around the first of December.

A corn crusher and small grain crusher, both driven by 30 horsepower motors, have been installed by the Valier & Spies Company of Vandalia, Ill.

The Beall Grain Company of Harristown, Ill., has rebuilt its elevator which burned. The equipment includes a cleaner and sheller, of Union Iron Works make.

Bear & Grussing, a partnership operating for many years at St. Joseph and Royal, Ill., has been

dissolved. They sold their St. Joseph house and John J. Grussing bought the interests at Royal which he will run independently.

J. C. Luce, Charles Lading and H. A. Bauer have filed articles of incorporation at Strasburg, Ill., as the Strasburg Co-operative Equity Exchange Company, capitalized at \$20,000.

A 4,100-bushel elevator is to be erected at Belleville, Ill., for the Reichert Milling Company of Freeburg, Ill. The old elevator will be wrecked on the completion of the new structure.

New pumps, new receiving bins, 200 foot drag chain, iron roof and siding and electric motors are being installed by E. W. Moore & Co., operating at Junction, Ill., as the Junction Elevator Company.

MINNESOTA AND WISCONSIN

A. Johnson's elevator at Rushford, Minn., has been repainted.

The Davenport Elevator at Kanaranzi, Minn., is being repaired.

The Farmers Elevator Company of River Falls, Wis., is to paint its elevator there.

The Farmers Elevator Company, Inc., of Lewisville, Minn., has completed repairs on its elevator.

A 25,000-bushel elevator, cribbed and steel clad, is being erected at Bigelow, Minn., by Spracher & Co.

An electric motor has been installed in the elevator of the Hubbard & Palmer Company at Northrop, Minn.

The Roseau County Farmers Co-operative Elevator & Mercantile Company of Roseau, Minn., has been dissolved.

F. L. Furney has leased the Hedberg Warehouse at Ogilvie, Minn., and is conducting a grain, feed and feed mill business there.

The Interior Elevator, the old Peavey house, at St. Louis Park, Minn., has been bought by the International Milling Company.

William G. Meyers has succeeded as manager of the Farmers Co-operative Elevator Company at Frost, Minn., by L. B. Lund.

P. O. Christianson of Ada succeeds T. F. Slatery as manager of the Equity Co-operative Exchange Elevator at Waterville, Minn.

The Victoria Elevator Company's new elevator at Corvusa (Litchfield p. o.), Minn., has been completed. Marshall McEwen is manager.

The Henning Farmers Elevator Company of Henning, Minn., has filed articles of dissolution. The company has been in business there for 30 years.

The elevator of C. J. Schmidt at Waunakee, Wis., has been repaired and improved. The scales have been enclosed and other improvements have been made.

W. J. Peiffenberger has been taken in as partner by H. P. Ulwelling of Rose Creek, Minn., and the two will operate under the name of H. P. Ulwelling & Co.

A new addition is being built to the warehouse of the Farmers Co-operative Creamery at Milaca, Minn., for grain storage and machinery for grinding and mixing feed will be installed.

The Ettrick Produce & Trading Company of Ettrick, Wis., will enlarge its elevator and improve it. Plans for the installation of a feed mill and the addition of a building to the elevator were discussed.

Considerable improving and remodeling has been done to the elevator of the Farmers Grain & Supply Company at Rushmore, Minn. New scales have been installed and a new dumping hoist operated by air pressure is now in use.

WESTERN

A grain warehouse is to be erected by E. Firchau at Albany, Ore.

A \$20,000 warehouse is to be erected at Santa Fe, N. M., for the Santa Fe Hay & Grain Company.

A certificate of dissolution has been filed by the Boulder Milling & Elevator Company of Boulder, Colo.

O. H. Brown, formerly of Soda Springs, Idaho, has opened a grain brokerage office at Hayward, Calif.

To conduct a general grain and milling business the Davidson Company has been incorporated at Alhambra, Calif.

An addition is being built to the mill of the Richmond Grain & Feed Company of Richmond, Calif., at a cost of \$2,700.

A new piler driven by a three-horsepower gas engine has been installed by the McDonald Grain Company of Molson, Wash.

A number of improvements have been made to the plant of the Golden Mill & Elevator Company at Golden, Colo., including new warehouse, Carter Disc Separator, a 10-ton Howe Dump Scale, etc.

The Stone Grain Company has absorbed the assets of the Farmers Elevator Company at Clovis,

N. M. Robert Stone is secretary-treasurer and manager of the firm. The firm is capitalized at \$150,000.

The capital stock of the Juab County Mill & Elevator Company of Nephi, Utah, has been increased from \$20,000 to \$50,000.

W. C. Bailey & Son's new elevator at Hill City, Idaho, has been completed. The Union Iron Works of Decatur, Ill., furnished the machinery.

The McLean Elevator Company of Becket, Mont., has bought three Wonder Grain Cleaners manufactured by the Weller Manufacturing Company.

The Barton Grain Company of Kennewick, Wash., has changed its name to the Barton-Gleason Company. I. S. Gleason is now interested in the firm.

The elevator of the Farmers Elevator Company at Hayden, Colo., has been leased to C. L. Dinius, who will act as purchasing agent of the Hungarian Mills at Denver.

The Port Commission Elevators at Seattle, Wash., have been taken over by the Bunge Western Grain Corporation which will act as operating agents of the Commission.

The elevator of the Occident Elevator Company at Ollie, Mont., which was destroyed recently by fire, is to be rebuilt. The plant will be of the same size and construction.

C. S. Pike of Van Nuys has bought the property of the Poultrymen's Grain & Supply Company of Van Nuys, Calif., which has been conducted for some years by L. W. Serrel.

The Farmers Wheat Shipping Association, organized and incorporated this fall at Scobey, Mont., has leased one-half of the Scobey Grain Company's elevator and is now operating.

Offices have been opened at Casper, Wyo., by the Fred W. Elder Grain Company, wholesale dealers in grain, hay and mill feed. The company's headquarters are at Hastings, Neb.

A grain brokerage business has been opened at Hayward, Calif., by O. H. Brown, formerly of Soda Springs, Idaho. The company will handle wheat, oats, barley, corn, kafir, milo, millfeeds, etc.

MISSOURI, KANSAS AND NEBRASKA

Goode & Harriman have bought the J. H. Lampkin Elevator at Centerview, Mo.

L. B. West is manager of the Norman Elevator Company at Whitney, Neb.

F. E. Janke of Otis, Colo., has leased the Farmers Elevator at Palisade, Neb.

The Farmers Elevator at Preston, Neb., is being improved with an interlocking gear dump.

The Dent Spur Elevator at Great Bend, Kans., has been leased by W. T. Hackett of Florence.

The Sterling Lumber & Investment Company's elevator at Lisco, Neb., has been completed.

Webster & Fields of Sioux City, Iowa, has bought the John Westrand Elevator at Belden, Neb.

J. J. Merillat's new 10,000-bushel iron clad elevator at Grove (mail to Delia), Kan., is in operation.

The Independent Elevator Company at Dalton, Neb., has been bought by the Dalton Grain Company.

The Missouri Pacific Elevator at Hickman, Neb., has been leased by J. F. Judah to Wm. Burk & Co.

The Gaskett Bros. of Moscow, Kan., are interested in the erection of a new grain elevator at Johnson.

The elevator of the Holmquist Grain Company at Homer, Neb., is to be operated by Jack Graham of Sioux City.

A new 15,000-bushel elevator is to be built at Norton, Kan., for the Derby Grain Company of Topeka, Kan.

The Farmers Elevator at Whiting, Kan., is being remodeled. The contract for the remodeling has been let.

The elevator of the Farmers Grain & Supply Company at Ulysses, Neb., has been leased by Amos Kilgore.

An 18,000-bushel elevator, of cribbed, steel clad construction is to be built at Watson, Mo., by the Turner Bros. of Red Oak.

The Rooksfehr Milling Company has bought the elevator and mill at Jamesport, Mo., operated by the Mason Grain Company.

The Halsted Milling & Elevator Company of Burrton, Kan., is going to move its 13,000-bushel elevator to a new location.

The Nye-Schneider-Jenks Elevator and business at Kennard, Neb., has been bought by the Farmers Grain & Lumber Company.

The capital stock of the Burlington Grain Elevator Company of St. Louis, Mo., has been increased from \$50,000 to \$200,000.

The elevator of the Solphin-Jones Grain Company at Magnet, Neb., has been overhauled and repaired and a concrete foundation has been put in.

The Burlington Elevator at Rockford, Neb., has been bought by A. L. Burroughs of Rockford from B. F. Cox from whom he leased the plant last year.

The following companies recently bought Wonder Grain Cleaners from the Weller Manufacturing

Company of Chicago: Kirk Grain Company, Scott City, Kan.; Farmers Elevator Company, Surprise, Neb.; James R. Raup, Timpkin, Kan.

The Fulton Co-operative Warehouse Company of Fulton, Mo., has bought a building from Alex Canter and will open a warehouse and handle grain and feed.

A new 20-horsepower motor of 22,000 volts is being put in by the Gering Mill & Elevator Company of Gering, Neb.; all transformers are being dispensed with.

The contract has been let by the Western Star Mill Company of Salina, Kan., for the construction of a new elevator there replacing the one which was damaged by fire.

The elevator of the Shannon Grain Company at Deweese, Neb., has been bought by Floyd Livingston and A. E. Hockman both of Hastings which they will operate as the Hastings Grain Company.

The Madrid, Neb., elevator of the Nye-Schneider-Jenks Elevator Company is being remodeled. New bins are being added, the old ones hopper bottomed and a new engine and electrical equipment installed.

The G. Clinton Adams Milling & Grain Company of Winfield, Kan., has moved its business to Kansas City, where it will operate at 265 Board of Trade Building as the G. Clinton Adams Grain Company.

The Sarcoxie Elevator Company was incorporated at Sarcoxie, Mo., to do a general mill, warehouse and elevator business. Henry Sabert, W. J. Miller, John Heman, Joseph E. Kempf and Alfred Wagner are interested.

The Missouri-Pacific Elevator at St. Louis, Mo., has been completed and began operations October 15. It cost \$2,000,000 and has a capacity of 2,000,000 bushels. It is of steel and concrete construction with handling capacity of 144 cars every eight hours.

The interest of G. C. Hipple of Hutchinson in the Security Elevator Company has been sold to Phil M. Clarke, formerly an officer of the New Era Milling Company, but more recently in the grain business at Hutchinson as the P. M. Clark Grain Company.

John Dobbs of Beatrice, Neb., has traded his string of elevators in Beatrice, Virginia and Armour, Neb., for a 3,000-acre ranch in Holt County just north of Atkinson. The deal represents more than \$100,000. Mr. Dobbs takes possession of the ranch January 1.

OHIO AND MICHIGAN

W. A. Linkhart's elevator at Sabina, Ohio, is being enlarged and improved.

Walter C. Hill's elevator at Rice (Continental p.o.), Ohio, is being enlarged.

The elevator of the Pickaway Grain Company at Circleville, Ohio, is to be remodeled.

A 60-foot addition has been built to the plant of the Tiffin Farmers Exchange Company of Tiffin, Ohio.

Luther C. Clark is receiver for the Hancock Co-operative Elevator & Supply Company of Findlay, Ohio.

The capital stock of the Lennon Elevator Company of Lennon, Mich., has been increased from \$25,000 to \$40,000.

Farmers of Isabella County, Mich., are organizing a company to operate a co-operative elevator at Mt. Pleasant, Mich.

Capitalized at \$50,000, H. C. King & Son, Inc., was incorporated at Battle Creek, Mich., to conduct a grain and feed business, etc.

Electric motors have been installed in the elevator of Wm. Gregg & Sons at Upper Sandusky, Ohio, replacing the gasoline engine.

The capital stock of the Farmers Elevator & Produce Company at Bad Axe, Mich., has been increased from \$30,000 to \$60,000.

A new warehouse is being built at St. Johns, Mich., by George F. Dimond & Co., replacing the one which burned this summer.

The elevator of the Williamstown Elevator Company at Williamstown, Ohio, which burned, has been replaced with a modern house.

The L. J. Jebavy Company's elevator at Custer, Mich., has been bought by B. F. Brunke of Fountain. Edward Brunke will have charge of the business.

L. C. Kern is now manager of the elevator of the Irvin T. Fangboner Company at Clyde, Ohio. He recently resigned with the Gray & White Company.

The elevator at Ohio City, Ohio, is being torn down by the Krugh Bros. of that town. The property was owned by the Northern Ohio Railroad which wanted it for tracks.

C. W. Carlton has bought back the elevator which he sold four years ago to the Chippewa Elevator Company at Chippewa Lake, Ohio, and will operate as the Chippewa Cash Elevator Company.

W. Hunsicker has bought the interest of Fred C. Betts in the firm of R. B. Yates & Co., of Wil-

liamsport, Ohio, and will continue the grain, coal and lumber business as C. W. Hunsicker & Co.

The mill and elevator at Stoutsville, Ohio, which Frank E. Jennings bought from E. A. Allen have been sold by him to Walter Goodman.

The Clifford Farmers Co-operative Association has been succeeded at Clifford, Mich., by J. A. Kelly & Co., for five years in the grain business there.

The elevator, coal sheds, potato house, etc., of the Gleaner Clearing House Association at Stanton, Mich., have been bought by the Stanton Elevator Company.

IOWA

New machinery is being installed in the elevator of Joe Johnson at Adaza, Iowa.

Business has been suspended, it is reported, by the Farmers Elevator of Walnut, Iowa.

The St. John Grain Company at Rock Rapids, Iowa, is being managed by J. C. Courtney.

A Kewanee Dump and scale have been installed by O. J. Kaschmitter at Whittemore, Iowa.

The Trans-Mississippi Elevator at Gray, Iowa, is to be operated under the management of Dave Hart.

A new elevator of 10,000 bushels' capacity is to be erected at Ryan, Iowa, for the Savage Lumber Company.

The Trans-Mississippi Grain Company will erect a 20,000-bushel cribbed, iron clad elevator at Smithland, Iowa.

The elevator of the Armour Grain Company at Rodney, Iowa, has been bought by the Rodney Grain Company.

McMasters & Nicholson have made plans for the erection of a 10,000-bushel elevator, motor driven, at Rodney, Iowa.

The plant of the Farmers Elevator Company of Ericson, at Jordan, Iowa, is being equipped with a new air pressure dump.

The Independent Grain & Lumber Company at Parkersburg, Iowa, is succeeded there by the Parkersburg Elevator Company.

C. E. Persinger succeeds John Sexton as manager of the Whiting Farmers Co-operative Elevator Company at Whiting, Iowa.

Mr. Albert has leased the elevator of B. B. Anderson & Sons at Montgomery, Iowa, and operates it as an independent elevator.

Clarence Chingren is manager of the elevator at Boone, Iowa, which the Quaker Oats Company bought recently from J. B. Maricle.

The Armour Elevator at Panora, Iowa, has been bought by the Farmers Elevator Company and will be equipped with an automatic scale.

An addition has been built to the elevator of the Farmers Co-operative Company at Dallas Center, Iowa, which has capacity of 14,000 bushels.

The elevator of the Audubon Co-operative Exchange, Audubon, Iowa, has been leased by the Trans-Mississippi Grain Company of Omaha.

The elevator and coal business of Loeltz & Dozler at Breda, Iowa, has been sold to Mr. Roth who will take possession of it in the near future.

The elevator of M. H. Spurgeon & Son at Truesdale, Iowa, has been bought by K. R. Frazier & Son of Colorado who have taken possession.

An electric motor has been installed and improvements made to the plant of the Glen Beach Grain & Coal Company of Shenandoah, Iowa.

Two grain bins have been erected at Sheldon, Iowa, by C. M. Anderson, with capacity of 15,000 bushels. The elevator proper holds 35,000 bushels.

The Garver Grain Company is interested in the erection of a grain elevator at Clearfield, Iowa. It will be of cribbed and reinforced concrete construction.

The elevator of the Independent Grain & Elevator Company at Lake Mills, Iowa, has been leased by them and the company is going out of business.

O. U. Johnson is manager of the Farmers Elevator Company at Elberon, Iowa. He was formerly with the Farmers Co-operative Society at Bode, Iowa.

A new elevator of cribbed construction and of 20,000 bushels' capacity has been completed at Turin, Iowa, for the Farmers Elevator Company of that place.

The Trans-Mississippi Grain Company is interested in the erection of a 20,000-bushel elevator at Smithland, Iowa, and has let the contract for its erection.

W. W. Horras is president and treasurer of the What Cheer Grain & Fuel Company which has been incorporated at What Cheer, Iowa, capitalized at \$7,500. N. L. Fuller is vice-president and secretary.

The West Elevator at Roland, Iowa, has been sold by the Farmers Co-operative Company to C. B. Johnson of Marshalltown for \$6,500. Possession is to be given this month. The Farmers company bought it from O. M. Anenson a year ago last May.

Just a year ago Mr. Anenson leased the house for one year and in partnership with M. M. Egglund conducted it under the name of the Roland Grain Company.

The old De Groote Elevator at Rutland, Iowa, has been bought by farmers of that neighborhood and a new elevator is to be erected on the site of the old one which is being torn down.

The Bryantburg (Iowa) Elevator is to be conducted under the management of J. W. Scott who operates an elevator at Independence. Ralph Webb will be in charge of the elevator.

Harry Moore and Howard Good have organized at New Hartford, Iowa, as the New Hartford Elevator Company and are erecting a new elevator on the site of the one destroyed by fire.

The G. R. Spurgeon Elevator Company's new 60,000-bushel elevator at Early, Iowa, is now ready for operation. It is a modern and complete house and will be managed by Fred Scott of Galva.

The grain, coal and merchandise business of M. C. Rucker at Gladstone, Iowa, has been sold by him to Frank Dostal, Jr., and James Hrabak of Vining. Possession will be given November 1.

OBITUARY

BEDFORD.—James W. Bedford, associated with the W. H. Letton Seed Company, Atlanta, Ga., died suddenly at his place of business on October 10. His widow survives him. He was 47 years old.

CLARK.—James Dallas Clark, a member of the Chicago Board of Trade, died at Harvard, Ill., on October 11.

DALEY.—Cornelius Daley, a prominent feed and flour man of Dunkirk, N. Y., died from injuries received in an automobile accident. His widow and two daughters survive him.

DONNETT.—Frederick Donnett died after a short illness, aged 87 years, at his home in Columbus, Ind. He was engaged for years in the grain and milling business at Columbus. He is survived by his widow, four sons and one daughter.

FRENCH.—Rowland B. French, for 30 years a member of the A. B. Brown & Bros. of Boston, Mass., died at his home there on October 14 after an illness lasting over a year. His widow survives him.

GARVIN.—Henry Garvin died at his home in Philadelphia, Pa., after a short illness. He was for 20 years superintendent of the Twentieth Street Elevator of the Philadelphia Grain Elevator Company.

KINGSBURY.—George Kingsbury died from heart disease on October 22 aged 77 years. He was a pioneer grain dealer of Ripon, Wis.

LEE.—John R. Lee, for 20 years in the grain business at Ness City, Kan., died, aged 77 years.

MURPHY.—P. J. Murphy said to have been one of the first grain elevator operators in Nebraska, died, aged 83 years, at his home in Omaha, Neb.

NORTHBRIDGE.—George D. Northridge died on October 20 aged 60 years. He had been in the feed and flour business at Malone, N. Y., for years.

O'KEEFE.—Thomas O'Keefe died, aged 66 years, on October 24. He was for 20 years manager of the feed and flour department of the H. J. Goelzer Department Store at Plymouth, Wis.

PAYNE.—Clayton H. Payne died on October 17 aged 55 years. He was long connected with the

feed trade in Lewis and Oneida Counties and retired two years ago at Stittville, N. Y.

PENDER.—William Pender died recently aged 53 years. He was a wholesale hay and grain dealer of Dubuque, Iowa.

STRATTON.—George Lyman Stratton, president of Stratton & Co., manufacturers of and merchants in grain and flour, died on October 14 at his home in Lexington, Mass. He was for years in business at Concord, N. H.

SWANTON.—James L. Swanton died on October 25 at Minneapolis, Minn. He was for 42 years a resident of Minneapolis and was a charter member of the Chamber of Commerce. In the early days he was connected with A. D. Mulford, the Great Western Elevator Company and the Dibble Grain Company. He is survived by his widow.

TAYLOR.—On September 18, George E. Taylor, senior member of the firm of Taylor Bros., Camden, N. J., died suddenly.

THORNE.—Clifford Thorne, representative of the various cooperative organizations in railroad rate matters, died in London, England, after a short illness, from pneumonia. Mr. Thorne was active in formation of the U. S. Grain Growers.

WATSON.—George C. Watson, for 30 years in the seed business at Philadelphia, Pa., died at his home in Lansdowne, Pa., recently.

WILLIAMSON.—John Williamson, who for years was engaged in the feed and flour trade at Toronto, Ont., died recently aged 59 years, following an attack of influenza.

WOLFE.—J. Wolfe died at his home in Fremont, Ohio, where for years he was operator of the Lindsey Grain Elevator.

WRIGHT.—George P. Wright for a number of years manager of the elevators at Plainview and Breslau died aged 66 years at Plainview, Neb.

WRIGHT.—Herbert J. Wright, formerly with Balfour, Guthrie & Co. of Seattle, Wash., and weighmaster and checker for the Merchants' Exchange, Seattle, Wash., died recently.

FIRES—CASUALTIES

Hutchinson, Minn.—Fire destroyed the Wagner Elevator recently.

Warsaw, N. Y.—Charles R. Van Allen reported a small loss on October 30.

Burleson, Texas.—Fire destroyed the grain and feed warehouse of H. Miller.

Eolia, Mo.—The Eolia Elevator Company sustained a small fire loss in its warehouse.

Valley View, Texas.—Fire destroyed the elevator of Keel & Sons at this point.

Council Bluffs, Iowa.—Fire damaged on October 1 the Droge Elevator Company's house.

Cambridge, Iowa.—The Farmers Elevator here was destroyed by fire, with loss of \$10,000.

Embarass, Wis.—Fire destroyed the elevator of Earl Schmidt. The insurance was \$1,200.

Sacred Heart, Minn.—The E. S. Johnson Elevator was totally destroyed by fire on October 30.

Albion, Neb.—Lightning struck the Hord Elevator and tore several large holes in the roof.

Bowling Green, Ohio.—Slight fire loss was suffered by the Royce & Coon Grain Company recently.

New Hartford, Iowa.—The Moore & Good Elevator and feed mill burned out recently with a loss of \$8,500.

Ipswich, S. D.—The elevator of the Farmers Equity was damaged by fire started by lightning.

About 25,000 bushels grain were also burned. The loss amounted to \$10,000, fully covered by insurance.

Washington, D. C.—Fire damaged the Schultz Seed Store on October 16. The fire occurred in the warehouse.

Quebec, Que.—Fire damaged to the amount of \$50,000, the three-story grain warehouse of George Tanguay, Ltd.

San Antonio, Texas.—Fire damaged the elevator of the Blue Star Elevator Company with a loss of \$5,000.

Unityville, S. D.—Fire of unknown origin caused a total loss to the Sun Prairie Elevator Company on November 3.

Byersville (mail Dansville), N. Y.—Fire destroyed with a loss of \$10,000, the granary of Mrs. Catherine Kennedy.

Wainwright, Alta.—Fire on October 14 destroyed the United Grain Growers Elevator and coal shed adjoining it. Cause, spontaneous combustion. The loss amounted to \$40,000.

New Waverly, Ind.—Fire of undetermined origin destroyed the grain elevator with a loss of \$15,000 which is partly covered by insurance. Over 1,200 bushels of grain were destroyed.

Seneca, Mo.—Fire on November 9 destroyed the elevator of the Mace Milling & Elevator Company with capacity of 250,000 bushels. The origin of the

fire is unknown. The loss amounted to \$15,000. No grain was in the elevator at the time as it had not been used for some time.

Cunningham, Wash.—Lightning struck the elevator operated by the O'Neil Grain Company. The loss was not severe.

Glasgow, Mont.—The Occident Elevator was damaged by fire on October 27. An overheated exhaust pipe caused the blaze.

Jarves, N. D.—Fire on October 11 destroyed the office and engine room of Henry Hammerly. The elevator and grain were saved.

Fostoria, Ohio.—The Fostoria Transfer Elevator here was damaged slightly by fire, which originated from spontaneous combustion.

Winkel (mail Delavan), Ill.—Fire destroyed the Wayne-Culbertson Grain Elevator with a loss of \$2,000. No grain was destroyed.

Preston, Minn.—Fire destroyed the Farmers Co-operative Elevator with a loss of between \$6,000 and \$7,000. Cause of fire unknown.

Perrysburg, N. Y.—Fire on October 3 destroyed the feed mill of Elmer O. Wells with a loss of \$50,000, partly covered by insurance.

Laverne, Okla.—Lightning on October 17 struck the elevator operated by the Oklahoma City Mill & Elevator Company, causing small damage.

New Palestine, Ind.—Fire damaged the elevator of the New Palestine Grain Company on October 16. The origin of the fire is unknown.

Mason, Mich.—The Mason Elevator Company reports a small loss caused by locomotive sparks landing on the shingle roof of the elevator.

Little Rock, Ark.—Fire destroyed the warehouse of the Hayes Grain Company with five cars mixed feed and 500 tons hay with a loss of \$27,000.

Andover, Kan.—Fire destroyed the elevator here of the Kansas Milling Company with 700 bushels of wheat. C. B. McClaren operated the house.

Gaylord, Minn.—Fire on November 5 destroyed the Equity Elevator at this place which has been standing idle for about a year. The loss amounted to \$30,000.

Merrill, Iowa.—Lightning tore a large hole in the roof of the elevator of the Oyens Co-operative Elevator Company and damaged the electric motor slightly.

Owendale, Mich.—On November 6, the exhaust pipe hazard was the cause of damage by fire at the line elevator operated by the Michigan Bean Company.

Buffalo, N. Y.—The Evans Grain Elevator suffered a small loss by fire which occurred in the casing of a conveyor. At no time was the elevator proper in danger.

Freeport, Ill.—The elevator of the Farmers Elevator Company on October 4 was destroyed by fire which started around the electric motor. The loss amounted to \$30,000.

Mardenis (mail Huntington), Ind.—The Mardenis Elevator office building and oil house burned with a loss of \$10,000, partly covered by insurance. The elevator contained 3,500 bushels oats and 100 bushels wheat.

Royersford, Pa.—Fire destroyed the fertilizer and feed mill of J. A. Trinley & Sons with a loss of between \$75,000 and \$100,000 on October 4. The fire was caused by a piece of iron dropping into the grinder.

Saskatoon, Sask.—Fire destroyed the elevators of the Home Grain Company and the United Grain Growers with 8,000 bushels and 2,000 bushels grain respectively. The loss is partly covered by insurance. The cause of the fire is unknown.

RECEIPTS AND SHIPMENTS

Following are the receipts and shipments of grain, etc., at the leading terminal markets in the United States for October:

BALTIMORE—Reported by Jas. B. Hessong, secretary of the Chamber of Commerce:

Receipts		Shipments	
1923	1922	1923	1922
Wheat, bus..	2,010,484	1,093,377	1,786,442
Corn, bus....	16,322	1,870,518
Oats, bus....	77,911	492,152	1,844
Barley, bus..	161,554	154,314	58,314
Rye, bus....	62,024	1,409,395	47,143
Malt, bus....	13,306	125,458	985
Millfeed, tons	1,804	1,815
Straw, tons..	71	34
Hay, tons....	2,690	703
Flour, bbls..	204,342	151,620	87,032

CAIRO—Reported by M. C. Culp, chief grain inspector and weighmaster of the Board of Trade:

Receipts		Shipments	
1923	1922	1923	1922
Wheat, bus..	2,290	2,290	3,266
Corn, bus....	19,482	49,527	16,683
Oats, bus....	1,576,813	1,555,314	1,416,506

CINCINNATI—Reported by D. J. Schuh, executive-secretary of the Cincinnati Grain & Hay Exchange:

Receipts		Shipments	
1923	1922	1923	1922
Wheat, bus..	684,000	338,400	390,000
Corn, bus....	264,000	382,800	86,400
Oats, bus....	524,000	282,000	254,000
Barley, bus..	13,000	6,500
Rye, bus....	38,400	37,200	21,400
Ear Corn, bus.	55,200
Hay, tons....	5,093	4,037
Millfeed, tons	1,500	600

CHICAGO—Reported by J. J. Fones, secretary of the Board of Trade:

Receipts		Shipments	
1923	1922	1923	1922
Wheat, bus..	2,774,000	4,492,000	1,748,000
Corn, bus....	7,293,000	17,820,000	3,101,000
Oats, bus....	7,660,000	9,235,000	4,990,000
Barley, bus..	1,255,000	1,017,000	321,000
Rye, bus....	127,000	410,000	89,000
Timothy Seed, lbs.	4,419,000	4,577,000	1,804,000
Clover Seed, lbs.	1,681,000	1,293,000	514,000
Other Grass Seed, lbs.	2,729,000	3,302,000	833,000
Flax Seed, bus.	106,000	167,000	8,000
Hay, tons....	14,668	13,143	431
Flour, bbls..	953,000	1,515,000	816,000

CLEVELAND—Reported by F. H. Baer, traffic commissioner of the Chamber of Commerce:

Receipts		Shipments	
1923	1922	1923	1922
Wheat, bus..	93,337	115,802
Corn, bus....	119,000
R. R.	87,440	142,117	1,319
Oats, bus....	372,058	148,777	2,332
Barley, bus..	16,384	7,131
Rye, bus....	986	2,417
Hay, tons....	2,580	1,672

DENVER—Reported by C. B. Rader, secretary of the Grain Exchange:

Receipts		Shipments	
1923	1922	1923	1922
Wheat, cars..	475	317	70
Corn, cars....	184	277	85
Oats, cars....	75	135	43
Barley, cars..	69	16	29
Rye, cars....	2	9
Hay, tons....	127	146

DULUTH—Reported by Chas. F. MacDonald, secretary of the Board of Trade:

Receipts		Shipments	
1923	1922	1923	1922
Wheat, bus..	5,063,184	9,521,538	3,280,205
Corn, bus....	4,156	348,296
Oats, bus....	443,398	167,816	266,083
Barley, bus..	749,592	754,053	719,475
Rye, bus....	1,679,298	4,521,442	535,440
Flax Seed, bus.	2,453,883	1,161,153	1,555,464
Flour, bbls..	965,660	661,700	962,625

FORT WILLIAM, ONT.—Reported by E. A. Ursell, statistician of the Board of Grain Commissioners:

Receipts		Shipments	
1923	1922	1923	1922
Wheat, bus..	67,050,310	65,119,880	53,391,735
Corn, bus....	7,785	3,139	7,785
Oats, bus....	5,436,202	4,537,451	4,058,844
Barley, bus..	2,692,409	4,098,314	2,535,492
Rye, bus....	944,753	2,124,454	220,112
Flax Seed, bus.	974,243	510,375	468,271

INDIANAPOLIS—Reported by Wm. H. Howard, secretary of the Board of Trade:

Receipts		Shipments	
1923	1922	1923	1922
Wheat, bus..	561,000	398,000	367,000
Corn, bus....	923,000	2,468,000	616,000
Oats, bus....	1,210,000	1,028,000	970,000
Rye, bus....	25,000	67,000	60,000

KANSAS CITY—Reported by E. D. Bigelow, secretary of the Board of Trade:

Receipts		Shipments	
1923	1922	1923	1922
Wheat, bus..	6,355,800	7,082,100	3,106,350
Corn, bus....	715,000	658,750	625,000
Oats, bus....	1,866,600	780,300	756,000
Barley, bus..	232,500	27,000	71,500
Rye, bus....	41,800	16,500	6,600
Kaffir Corn, bus.	17,600	119,900	20,000
Hay, tons....	22,308	22,056	4,512
Flour, bbls..	80,275	116,350	640,575

LOS ANGELES—Reported by M. D. Thiebaud, secretary of the Grain Exchange:

Receipts		Shipments	
1923	1922	1923	1922
Wheat, cars..	352	313
Corn, cars....	129	90
Oats, cars....	90	80
Barley, cars..	206	201
Rye, cars....	1	4
Seed, cars....	20	23

MILWAUKEE—Reported by H. A. Plumb, secretary of the Chamber of Commerce:

Receipts		Shipments	
1923	1922	1923	1922
Wheat, bus..	267,400	417,200	209,179
Corn, bus....	514,720	1,740,520	410,729
Oats, bus....	5,073,800	2,299,545	2,894,000
Barley, bus..	1,186,580	1,123,380	341,180
Rye, bus....	164,200	326,865	100,465
Timothy Seed, lbs.	755,500	1,050,000	724,612
Clover Seed, lbs.	304,223	500,231	753,425
Malt, bus....	36,600	64,400	344,600
Flax Seed, bus.	120,650	71,735
Feed, tons..	113,400	11,540	7,954
Hay, tons....	1,764	1,584	480
Flour, bbls..	351,040	306,390	56,660

MINNEAPOLIS—Reported by G. W. Maschke, statistician of the Chamber of Commerce:

Receipts		Shipments	
1923	1922	1923	1922
Wheat, bus..	14,741,830	16,719,550	4,783,290
Corn, bus....	486,520	490,890	217,440
Oats, bus....	4,321,320	3,376,370	3,160,410
Barley, bus..	1,879,300	1,506,010	1,543,880
Rye, bus....	1,010,450	1,847,430	194,630
Flax Seed, bus.	1,952,810	1,072,430	407,550
Hay, tons....	2,905	2,240	326
Flour, bbls..	132,887	116,590	1,597,007

NEW YORK CITY—Reported by H. Heinzer, statistician of the Produce Exchange:

Receipts		Shipments	
1923	1922	1923	1922
Wheat, bus..	11,003,600	4,434,200	9,810,000
Corn, bus....	544,300	2,390,600
Oats, bus....	968,000	2,960,000	115,000
Barley, bus..	1,049,500	1,001,600	592,000
Rye, bus....	1,743,500	1,357,000	1,393,000
Timothy Seed, lbs.
Clover Seed, lbs.
Flax Seed, lbs.	5,008	6,744
Flour, bbls..	231,000	194,000
Hay, tons....	10,765	7,440
Flour, bbls..	1,233,136	798,988	698,000

MONTREAL, QUE.—Reported by J. Stanley Cook, secretary of the Board of Trade:

Receipts		Shipments	
1923	1922	1923	1922
Wheat, bus..	16,378,248	17,124,978	12,357,845
Corn, bus....	182,127	3,469,137	954
Oats, bus....	1,379,740	1,406,037	364,813
Barley, bus..	1,194,263	1,053,218	769,858
Rye, bus....	825,728	2,683,290	1,591,134
Flax Seed, bus.	107,409	62,718
Hay, bales....	89,895	96,410	8,575
Flour, bbls..	591,686	946,615	412,132

NEW ORLEANS—Reported by S. P. Fears, chief grain inspector and weighmaster of the Board of Trade:

Receipts		Shipments	
1923	1922	1923	1922
Wheat, bus..	1,010,396
Corn, bus....	129,940
Oats, bus....	56,765
Rye, bus....	47,142

OMAHA—Reported by F. P. Manchester, secretary of the Grain Exchange:

Receipts		Shipments	
1923	1922	1923	1922
Wheat, bus..	2,934,400	2,905,000	2,301,600
Corn, bus....	1,290,800	2,083,200	967,400
Oats, bus....	2,708,000	1,340,000	2,440,000
Barley, bus..	243,200	88,000	152,000
Rye, bus....	254,800	250,600	99,400

PEORIA—Reported by John R. Lofgren, secretary of the Board of Trade:

Receipts		Shipments	
1923	1922	1923	1922
Wheat, bus..	244,850	335,650	188,400
Corn, bus....	1,725,000	2,767,670	980,975
Oats, bus....	1,554,650	1,797,950	1,290,300
Barley, bus..	289,000	79,400	102,200
Rye, bus....	3,600	25,200	21,600
Millfeed, tons	43,540	34,020	39,200
Hay, tons....	4,590	3,720	160
Flour, bbls..	179,900	179,700	170,400

HAY, STRAW AND FEED

WEST VIRGINIA FEED LAW

The last session of the legislature of West Virginia amended the stock feed law of the state. The amendment consisted in abolishing the inspection fee. The amendment went into effect on July 25, so that it is no longer necessary to affix tax tags to feed shipped into West Virginia.

SHIP YOUR HAY

In their market letter of November 9, Albert Miller & Co. of Chicago say: We advise you to send everything to Chicago for the present—also consign and benefit by any advance that may come. Remember our specialty is consignments.

Straw: Big demand. Send us anything you have in the way of straw that is dry.

CURING ALFALFA HAY

There is a secret about curing Alfalfa hay, known to good hay-makers, says J. H. Sheperd of the North Dakota Agricultural College. They allow the plants thoroughly to wilt in the swath when cut, and then rake them into windrows with the butts of the stems outside, as much as possible. The drying process is then allowed to go on for a few hours; after which the hay is cocked in small stacks, and left until completely cured. By handling it in this way the leaves are kept moist, alive and evaporating water by their natural growth processes, just as they did when the plants stood upright. In that way they gradually dry out and cure the hay. The leaves stick to the stalks, and the hay is cured without the sun's bleaching it. Stooks cocked up while the crop is green settle into compact form, and, hence, shed the water well even during a rain. Stooks of Alfalfa hay cured in that way grow to look brown and sear, but when opened they show almost as green as fresh Alfalfa inside, and form a most palatable hay.

WHAT IS "MIXED" COWPEAS

Growers sometime misunderstand the term "mixed" as applied to cowpeas and the United States Department of Agriculture says that frequently a lot of cowpeas is shipped as mixed when it really consisted of one of more bags of several varieties.

For example, the lot may consist of 900 pounds total, made up of 200 pounds Whippoorwills, 300 pounds Brabhams, 300 pounds Clays, and 100 pounds Irons, each variety in separate bags. To sell such a lot of cowpeas on the basis of the discount price of "mixed" is short-sighted to say the least. It not only means a loss to the grower, but affords an opportunity for local shippers to reap an unearned profit by keeping each variety separate, accumulating large quantities of each, and selling on the basis of straight variety values. Only when two or more varieties of cowpeas are contained in the same bag and their identity lost should they be classed as mixed and sold at the prevailing discount.

The price of cowpeas is affected more or less by the supply of soy beans and velvet beans and the publicity given these crops by various agencies. Substitution among these three crops is not general, however, and the demand for cowpeas remains more nearly constant while the price of any one or two which may be in short supply is curbed by the relatively lower price of the crop of which the seed supply is greatest.

PIGEON GRASS SEED AS FEED

Many inquiries have been made at state agricultural colleges as to the feeding values of pigeon grass seed, and F. W. Christensen, animal nutrition specialist at the North Dakota Agricultural College, answered these recently when he said that pigeon grass has considerable feeding value and could replace part of the grain or mill feeds in a ration.

"The seeds should be rather finely ground and mixed with grain or mill feeds for the best results," said Mr. Christensen. "Unfortunately, very little experimental work has been done to determine the value of pigeon grass seed for feeding purposes or the best way to use it.

"A mixture of equal parts of light-weight oats and wheat bran contain the same amount of digestible matter as pigeon grass seed, that is, 63.6 pounds per hundred weight.

"Some years ago a feeding trial was conducted at the North Dakota Agricultural College with lambs in which unground pigeon grass seed and prairie hay were fed to one group and a mixture of wheat bran, equal parts, with Prairie hay to another group. A third group was fed Prairie hay and wheat screenings. In these trials the lambs in the various groups made very nearly the same gains which indicates that for feeding lambs pigeon

grass seeds have practically the same feeding value as a mixture of equal parts of wheat bran and oats."

ALFALFA WISCONSIN'S RECORD HAY CROP

Wisconsin Alfalfa maintained the highest condition of all hay crops during the entire growing season, making an average yield of 2.4 tons per acre compared to a yield of 1.45 tons for Clover hay. Last year's average yield of Alfalfa was 2.7 tons. The total tonnage is estimated to be 310,000 tons or 27 per cent more than last year.

OFFICERS HAY EXCHANGE RE-ELECTED

All officers of the New York Hay Exchange Association were re-elected at the recent annual meeting. Fred M. Williams as president begins his fourth consecutive term, a record in the organization. The other officers are C. S. Carscallen, first vice-president; A. F. Fisher, second vice-president; A. J. Nuttall, treasurer; R. J. O'Brien, secretary; directors, R. C. Tygert, H. A. Post, T. P. Huffman, C. McAllen, L. D. Ryan, E. O. Binzen.

NEW FEED BRANDS

"MARVEL" cereal scratch and chick feed for poultry and cereal feed for hogs. Charles O. Sandefur, doing business as Sandefur's Cereal Mill,



Owensboro, Ky., assigned to Anglo-American Mill Company, Owensboro, Ky., a corporation of Delaware. Filed May 7, 1923. Serial No. 180,301. Published October 30, 1923.

"BLACKHAWK" stock and chicken feed. International Milling Company, Minneapolis, Minn. Filed February 21, 1923. Serial No. 176,408. Published October 30, 1923.

"SWEETCO" feed for livestock. Sweetwater Cotton Oil Company, Sweetwater, Texas. Filed June 2, 1923. Serial No. 181,502. Published November 6, 1923.

Cornmeal, cereal scratch and chick feed for poultry, cereal feed for hogs. Charles O. Sandefur, doing business as Sandefur's Cereal Mill, Owensboro, Ky., assignor to Anglo-American Mill Company, Owensboro, Ky., a corporation of Delaware. Filed May 7, 1923. Serial No. 180,297. Published November 6, 1923.

"ST. PAUL QUEEN" wheat flour and stock feeds. Capital City Milling & Grain Company, St. Paul, Minn. Filed February 10, 1923. Serial No. 175,845. Published November 6, 1923.

"MAKE 'EM LAY" poultry foods, namely, poultry mash, scratch foods, growing food, and developing food. Fred D. Wikoff Company, Red Bank, N. J. Filed February 21, 1922. Serial No. 159,675. Published November 6, 1923.

ADVANCED HAY RATES CANCELLED

The Interstate Commerce Commission has found the proposed increased rates on hay in carloads from Clover Leaf stations in Ohio, Indiana and Illinois to Cairo, Ill., and Evansville, Ind., when destined for southeastern and Carolina territories to be only partly justified and suspended schedules were ordered cancelled.

By schedules filed to become effective May 15, 1923, the Toledo, St. Louis and Western Railroad proposed to cancel proportional commodity rates on hay from their local stations to Cairo and Evansville when destined to southeastern points. The Kehoe Hay Company of Terre Haute, Ind., and

Voris & Sons of Stewardson, Ill., protested and the operation of the schedules was suspended until October 12.

At a hearing held by the Commission it was found that the advanced rates were not justified and notice was given to cancel them and return to the old schedules. The hearing showed that the proposed rates from Illinois points were not justified but that it is possible that some revision of rates should be made to Evansville. The records were not sufficient to determine that, however.

FEED FOR COWS

Experiments conducted by the Ohio Agricultural Experiment Station indicate that Clover, Alfalfa and soy bean hays are probably the best for milk production. These legumes contain more of the essential minerals than other hays. The experiments also indicated that the way in which hay is cured has an influence on the availability of the minerals which it contains, and that hay cured without heavy dews or rains or without long exposure to the sun is the most nutritious.

ORCHARD GRASS POPULAR

Farmers in the South are coming more and more to use Orchard Grass, in some instances replacing Bluegrass with it. Orchard Grass cannot be safely sown in the fall and consequently seeding should be done in late winter or in late summer.

In one county where the Orchard Grass is sown primarily for seed production, only about 12 pounds of seed is sown to the acre. For a good pasture, however, a thick stand is desirable as it prevents the formation of large bunches which make a rough turf. If planted alone, it is advisable to plant 20 pounds to the acre for pasture. When Clover is sown with it, 10 to 12 pounds of Orchard grass, 4 to 6 pounds of Red Clover and 2 to 3 pounds of Alsike Clover make a good mixture.

ALFALFA SUPERSEDES CLOVER

Farmers in upper Wisconsin, particularly in Shawano County are turning to Alfalfa on account of its drought resisting qualities. Heretofore the country was known as a Clover producing region. During the past two years the acreage of Alfalfa has jumped from 300 to over 2,000 acres in Shawano County. The light sandy soil is first treated to lime and then Sweet Clover is turned under to give the necessary humus before the Alfalfa is seeded. With the new seeding of Alfalfa, the roots will penetrate the soil to at least twice the depth that either Clover or Timothy will do. Consequently when the hot, dry weather of the summer occurs, Alfalfa has a far better chance to live through than will the more shallow rooted crops such as Clovers and Timothy.

MONTANA HAY

Based upon an average yield of 1.80 tons per acre for all tame hays, the preliminary estimated production of tame hay is 1,975,000 tons, which is slightly less than last year's crop and compares favorably with the 10-year average crop of 968,000 tons. The average yield for last year was 1.90 tons, and the 10-year average yield was 1.75 tons. Dry periods in the eastern counties, hoppers in all sections, and generally unfavorable growing conditions at different periods, has reduced the average yield, chiefly with respect to Alfalfa. Quality has been lowered materially by rains during the haying season.

The production of wild hay is estimated at 610,000 tons, upon an average yield of .89 tons per acre. Last year's crop was 623,000 tons, and the yield .90 tons. The 10-year average crop has been 598,000 tons, and the average yield .85 tons. Wild hay did not make the desired early growth, was injured to some extent by hoppers, and cut short in the east and southeast by hot dry weather.

HAY SHIPPERS SHOULD CO-OPERATE

Shippers may assist the railroads in giving more efficient service by observing the following rules:

Hold LCL for Carload Movement.—If you are making daily shipments of less-carload freight to the same territory and loading to a transfer point, hold your shipment until the second or third day in order to make a straight carload and bill through to destination.

Your freight will receive quicker movement and rate will be less if handled in carload lots.

Complete Your Loading Before Closing.—Should the loading of a car not be completed at the usual time of closing it is very desirable to work a little overtime and finish the loading, as this will expedite the movement and delivery of your consignment.

Co-operate with Your Agent in Switching Service.—Consult the railroad agent or yardmaster and decide on the time of day to have loaded cars ready to remove from your industry in order to fit in with the departing time of the trains on which your shipments will go forward. By keeping in touch with the agent or yardmaster the movement of your cars will be expedited by finishing the loading to suit the daily program of the switching crews that gather up your loads from your or other

industries. It is necessary to have regular hours for switching crews to do the work at certain industries to accomplish the best results for all concerned.

Co-operate with Billing Agent.—Furnish the billing agent full instructions that will permit the waybill being made up to move your shipments before the loading is complete if possible, and in all cases before load is removed from your industry.

HAY GRADES TO BE SIMPLIFIED

Simplification of existing Federal hay grades on the basis of recent research work and in response to requests for modifications from producers, handlers, and consumers of hay, is to be made by the United States Department of Agriculture. The number of classes and grades will be reduced and a simpler method of determining grade will be adopted, the Department says.

Maurice Niezer of Fort Wayne, Ind., former president and for many years chairman of the Grades Committee of the National Hay Association, has been appointed by the Department as a consulting specialist to advise in the hay grades work. The announced policy of the Department is to simplify the grading system in a manner consistent with good grading practice and to conform as nearly as possible to the commercial grades now in general use.

HAY CONDITIONS IN MISSOURI

Missouri's yield of hay is better this year than last with the exception of Timothy.

Clover hay averages 1.3 tons per acre on 598,000 acres, or 777,000 tons. Alfalfa hay averages 2.35 tons per acre on 170,000 acres, or 400,000 tons. Grain sorghums show 85 per cent condition, or 24.65 bushels per acre. The crop is being cut under favorable circumstances. Cowpeas show a condition of 78 per cent. Pods are heavy and the crop is growing nicely in the southeast, but it is poor in the southwest. Soybeans promise 85 per cent. Harvesting is under unfavorable conditions, but the crop is heavy.

Alfalfa seed indicates two bushels an acre, or 8,000 bushels. The seed condition is 78 per cent. Clover seed shows 60 per cent condition, with 1.2 bushels an acre. The crop is the poorest in many years. Hullers are reluctant to engage in threshing. Many scattered fields may not be threshed.

Condition of pastures is 88 per cent, being good everywhere except in the southwestern counties, the eastern and central regions. Record rains helped pastures.

FEED MANUFACTURER EXHIBITS

BY B. S. BROWN

The Kansas City Industrial Exposition conducted under the auspices of the Chamber of Commerce of Kansas City was held from October 10 to 24, in the American Royal Building. Four hundred and twenty booths, all that could be crowded into the three floors of the building, were filled, with 220 firms making exhibits. Universally, exhibitors declared the Exposition to be the finest in which they had ever exhibited. Over 100,000 people enjoyed the wonderful displays. Tons of souvenirs and printed matter were distributed by exhibitors. An 80,000,000 candle power searchlight on top of the Kansas City Athletic Club Building pointed the way to the American Royal Building every night, the effect of which was plainly visible 25 miles from the center of the city. The Exposition was advertised as "Ten Big Shows in One." These 10 included: Better Business Show, Banking and Investments, General Merchandise, Food Products, Machinery Hall, Building Materials, Radio, Electrical, Graphic Arts, Wholesale Exhibits.

The "liveliest" booth in the "bunch" was a display of chick feed by the Quisenberry Feed Manufacturing Company, whose main office is in Kansas City, and branch office in Buffalo, N. Y. Pretty brown leghorns, 200 of them, ran about chirping their happiness after being fed their first real meal of Quisenberry "Buttermilk Starting Food," to which was added, later, the "Husky Chick" (fine) feed once daily. The chicks were shipped direct from a Columbia, Mo., hatchery known as the Missouri Poultry Farm, to the booth where they were used effectively to demonstrate the merits of the displayed feed for 14 days. A cage with a White Leghorn inside with a sign hung on the outside of the cage stating: "The Factory: the Hen" attracted much attention and created much amusement. Scratch grain, laying mash, growing mash and buttermilk starting food represented the raw material, the hen, the factory, and the finished product, eggs, were used in the striking demonstration. The company's three grades of scratch grain, which were displayed in bags and in bulk, were "Egg Maker," "More Egg" and "Big Q."

Their demonstrator, M. A. Smith, who is the company's general utility man from the mill, stated that this exhibit was one of the very best forms of advertising the company had ever used, as he could get in better touch with people who were interested in poultry raising. Thus, dealing directly with their various poultry problems personally, helped to create a warm regard for the

company's products. He did not attempt to sell the feed but used the demonstration to advertise, exhibit and instruct.

The Quisenberry company will hold another demonstration at the Live Stock Show, in the American Royal Building, beginning November 17 and ending November 24, as they consider this form of exhibiting a successful factor in sales promotion. From 25 to 30 dealers, from the surrounding territory, one even coming from Enid, Okla., called at the booth at the Industrial Exposition and talked over their problems with Mr. Smith. He told them how to promote sales, and how to get better results from their advertising.

CORN'S VALUE AS FEED CAN BE INCREASED

The value of whole Yellow corn as a feed can be greatly increased by the addition of 25 parts of soy bean or peanut flours to 75 parts of the corn, according to deductions made by Dr. D. Breese Jones, chemist in charge of the protein laboratory of the United States Bureau of Chemistry, who came to his conclusions through a series of experiments conducted by him.

His experiments showed that the proteins of corn are deficient in lysine and tryptophane, the amino acids that are essential for the growth of animals, and that supplementing this feed with these flours, which are relatively high in amino acids, a mixture of proteins results which has been found adequate for normal growth. As whole corn constitutes a large portion of the ration of the animals, these experiments are of particular interest to feeders who will now know how to supplement the straight corn to secure the greatest amount of nutrition for their animals.

ALFALFA MARKET IMPROVED

"The Alfalfa market during the past week has shown considerable strength," says the Graham & Martin Grain Company of St. Louis, in its letter of November 10. "Receipts of Alfalfa continue light, only seven cars being received here today. Ready sale was made of the receipts at full prices.

"There is an excellent unsupplied demand for all grades of sound Alfalfa hay, and the market promises to even do better as the demand is such that will warrant continued strong values.

"There is very little Clover hay in this territory, and the trade is compelled to buy up Alfalfa. There is not only a good local feeding demand, but also a shipping demand. The mills are also in the market for liberal supplies, and as a whole the situation is very strong.

"Remember we specialize in Alfalfa hay, and are in position to handle your hay on this market to the best possible advantage. We give each and every car our individual care and are also buyers of Alfalfa hay for the mills. This gives us the first call on Alfalfa hay."

DON'T LET TIMOTHY STAND TOO LONG BEFORE CUTTING

Don't let Timothy hay stand too long before cutting, advises the United States Department of Agriculture. Only a small percentage of Timothy hay marketed each year grades No. 1, statistics show, but the Department's hay grading specialists have found that a large part of the Timothy hay which has been grading No. 2 and No. 3 Timothy would have been No. 1 had it been cut at an earlier stage of maturity, provided the method of curing and weather conditions were favorable for producing a good quality of hay.

Under the United States Timothy grades, which have been recommended recently by the Department of Agriculture, color alone determines the grade unless the hay is very weedy. Color in hay is caused by the amount of brown leaf surface, brown or bleached heads, and bleached and off-colored stems. It has been found that there is a close relation between the time of cutting or stage of maturity of Timothy hay, and the amount of color.

In the United States grades for Timothy hay the maximum allowance of brown leaf surface for No. 1 Timothy is 40 per cent with 2 per cent of brown or bleached heads, and 5 per cent of bleached or off-colored stems. To prevent the color from exceeding these limits, it has been found that under normal conditions, the hay as cured by the average hay maker must be cut not later than when in full bloom. In some sections, and under certain conditions, it may be advisable to cut even earlier.

There appears to be an idea prevalent among producers in some sections that early cut hay is more washy or laxative than hay that is riper, but there is practically no accurate data on this subject. Agricultural experiment stations have found, however, that the sooner hay is cut after coming into full bloom, the more total digestible nutrients it will contain. This earlier cut hay also will be palatable and relished by stock.

Since hay cut at this time is more nutritious, and will also be of a higher commercial grade than late cut hay, producers are urged to cut their hay at the proper time unless it is imperative that more important work must be done on other crops.

Weather is also an important factor in producing

good hay. Best quality hay is often almost ruined by rain. While hay which has been stained by rains or heavy dew may often be fed on the farms to advantage, it is discounted in the markets. Producers should keep this damaged hay separate from the better hay, as it is impossible to separate it later when baling or marketing. A little damaged hay mixed with the good frequently causes the buyer to refuse to take the better hay except at a very heavy discount. Only choice qualities of hay bring the higher prices, therefore, producers should harvest their hay properly.

The suggestions recommended by the Department of Agriculture are summarized as follows:

1. Start cutting your Timothy hay as soon as possible after the meadow reaches early or first full bloom.

2. Cure in the manner that will best preserve the color and quality of the hay.

3. If any hay becomes stained or damaged from rain or too long exposure to the sun, store apart from the good hay, also keep weedy hay separate from the clean hay.

CUTTING SWEET CLOVER FOR HAY

Last year the Ontario Experiment Station conducted a number of experiments with White Blossom Sweet Clover, to determine the best times for cutting, both for green fodder and for hay. The greatest yield of green fodder per acre, 17.27 tons, was produced by cutting the crop when half in bloom, and the smallest yield, 11.37 tons per acre, when cut before the buds had started to form. The greatest yield of hay, 6.03 tons per acre, was produced by cutting with one-half the seed pods formed, but the quality of this hay was very poor. The smallest yield of hay, 1.80 tons per acre, was obtained when cut before the buds started to form.

The best quality of hay was produced where the plants were cut in the late bud stage. The yield per acre in this case was 3.57 tons. It should be noticed, however, that even in this case, although the Clover was rather fine in the stalk for Sweet Clover, and unusually leafy, it cured out quite coarse and woody, and considerable of the stalks went to waste in feeding. Nevertheless, in feeding the dairy cows ate it well and seemed to relish it.

HAY STRONGER IN NEW YORK

BY C. K. TRAFTON

Early in the month under review the hay market was in a decidedly unsettled and unsatisfactory condition, practically everyone concerned being inclined to grumble. Still it must be admitted that the general position was particularly unsatisfactory to farmers, country shippers and receivers. During the period under consideration nearly all buyers were manifesting decidedly little interest and especially as far as common and inferior grades were concerned. This was notably true of poor grades of heavy Clover, which was nearly unsaleable, it being frequently difficult if not impossible to obtain reasonable bids.

It was the consensus of opinion that the conspicuous depression, particularly in common or inferior descriptions, was largely attributable to fairly large receipts which embraced an unusually large quantity via canal and river boats. Furthermore it was averred that these boats contained an unusual percentage of ordinary or poor hay from Canada and it was the consensus that this hay was in the main so undesirable as to be greatly neglected.

As a matter of fact, it was almost universally agreed that the bulk of buyers manifested more than ordinary reluctance to negotiate when the hay on offer was not of superior quality. In the judgment of many conservative and experienced members of the trade this unusual or extraordinary preference for Choice Timothy or No. 1 Light Clover Mixed was perhaps largely traceable to the fact that there were an uncommonly large number of race horses gathered in this territory during the past month, and as everyone knows race horses are supposed to be highly valuable and presumably they have acquired a distinctly discriminating taste for food of superior quality.

Late in the month there was a rapid and conspicuous change in the temper of the market, the sluggishness and narrowness being succeeded by greater activity and buoyancy. Suddenly there was a pronounced increase in the demand which convinced many keen observers that a great many buyers had remained out of the market far too long and therefore they had permitted their stocks to run down to a dangerously low level. Consequently they had abruptly awakened to the fact that it was high time to prepare for future requirements before winter set in and lake canal navigation closed. When they attempted to buy on a larger scale they awakened to the fact that they had waited too long, as receipts had been falling rapidly and consequently offerings were greatly reduced. Therefore in order to secure supplies they found it necessary to make appreciably higher bids. As previously suggested, this was notably true of superior descriptions, which were remarkably scarce. As a result practically all buyers found it necessary to pay far more attention to merely good grades such

as No. 3 or No. 2. Because of this it was soon found that best lots of No. 2 Timothy were commanding only a trifle less than quoted for No. 1. It was small wonder, therefore, that the price difference between choice and inferior grades was unusually wide.

In some quarters it was declared that the stronger trend was partly owing to the fact that farmers and country shippers had been showing indifference about shipping to this market, claiming that they had been marketing their surplus at home or at interior markets to better advantage. According to some Western advices the firmer tendency was partly chargeable to the wonderful scarcity and resultant phenomenally high prices for corn throughout the interior during October.

Straw had undergone surprisingly few changes during the month. No. 1 rye straw has ruled firm, and especially choice long straw from this state, as receipts were limited, but common qualities were dull and unsettled.

QUARANTINE IN MISSISSIPPI VALLEY STATES

Heavy losses have been sustained recently by growers of Alfalfa in our western states on account of the presence there of the Alfalfa weevil. The insect so far has not been found east of the Rocky Mountains and in the hopes of keeping the pest from spreading eastward, official inspectors of the Mississippi Valley at a conference in Ames, Iowa, on September 14, decided to place an embargo upon the shipment of Alfalfa hay from the infested areas for the protection of Alfalfa growers in these states. The proclamation issued by the Governor of Illinois and published herewith is typical of the quarantine placed by the Mississippi Valley States.

WHEREAS, the Department of Agriculture has reported to me that an insect known as the Alfalfa weevil (*Phytonomus posticus* Gyll) injurious to Alfalfa and other forage crops and not known to be present in this state, is present in the states and countries hereinafter designated as the infested district and is likely to be introduced into this state in shipments of Alfalfa hay, other hays, cereal straw, to the detriment of the agricultural interests of this state.

NOW, THEREFORE, I, Len Small, governor of Illinois by virtue of the power and authority in me vested by the statutes, do hereby establish a quarantine against the infested district, namely: the state of Utah; the entire state of Wyoming until the state shall establish and maintain an effective quarantine for the protection of the uninfested parts of the same; all that part of Idaho lying south and southeast of the south line of Idaho County; the counties of Delta, Gunnison and Montrose in Colorado; the counties of Washoe, Storey, Ormsby, Pershing, Lyon and White Pine in Nevada; the county of Sierra in California; and the counties of Baker and Malheur in Oregon; and forbid the importation directly or indirectly from the said infested district, into Illinois, of Alfalfa hay and others hays of all kind and cereal straw, grown or stored in the infested district, without exception, including their use as packing, or for any other purpose, and do hereby proclaim and direct that any such shipment coming into the state from the said infested district shall be destroyed or returned to the original consignor as the owner thereof may elect; and do hereby admonish all officers of the state of Illinois charged with the enforcement of the laws of this state to be diligent in preventing and punishing the acts herein prohibited.

This proclamation shall take effect and be in force on and after the 15th day of October, 1923.

In witness whereof, I have hereunto set my hand and caused the great seal of state to be affixed.

SUNFLOWER CROP LARGER THAN LAST YEAR

Sunflower seed production in Missouri, Illinois and California is estimated to be 11,500,000 to 14,000,000 pounds compared with 8,000,000 to 10,000,000 pounds last year, according to information obtained by the United States Department of Agriculture. The larger production is due chiefly to the increased acreage in southeastern Missouri and southern Illinois. About 17,000 acres of sunflower were planted in Missouri but a larger acreage than usual was abandoned because of the late, wet spring, so that the acreage harvested for seed was believed to be about 3,000 acres less than the planted acreage. A yield per acre of 550 pounds compared with about 600 pounds last year would result in a production close to 8,000,000 pounds. Estimates as high as 9,000,000 and upwards have made for the 1923 Missouri crop compared with 6,000,000 to 7,000,000 pounds last year.

The Illinois crop is estimated at 2,000,000 pounds or more compared with upwards of 1,000,000 pounds last year. Some correspondents indicate as much as 3,000,000 pounds this year and 2,000,000 pounds last year. No acreage and yield-per-acre figures for the state are available at this time but the consensus of opinion is that the Illinois crop is much larger than last year.

The crop in the San Joaquin Valley of California is estimated at 1,800,000 to 2,000,000 pounds compared with 700,000 to 800,000 pounds last year.

Harvesting in Missouri began about September 25 and in Illinois on October 1. Practically no movement had taken place in Illinois up to October 15, but in Missouri 10 to 25 per cent or more of the crop was reported to have left growers' hands. In California over 90 per cent was sold by that date.

The quality of the seed in general is reported to be about the same as last year.

The imports of sunflower seed at New York and

Baltimore amounted to approximately 5,500,000 pounds during the calendar year 1921, 3,800,000 pounds in 1922, and 3,600,000 pounds for the period January 1 to October 20 of this year. While the bulk of the sunflower seed during the first six months of this year came from Holland, the larger portion during the two preceding years (more than 5,000,000 and 2,000,000 pounds in 1921 and 1922 respectively) came from Argentina.

The falling off of imports from Argentina during the latter part of last year and the first half of this year was due largely to the fact that the 1922 crop in that country was small. The 1923 crop is estimated to be close to 10,000,000 pounds, or about twice as large as the 1922 crop. Much sunflower seed from the 1923 crop is reported to be available for export from Argentina as the demand has been slow.

INDIANA FEEDINGSTUFFS

During 1922 Indiana farmers bought approximately 340,197 tons of commercial feeds valued at retail at \$14,244,175, according to the bulletin on "Commercial Feedingstuffs" recently issued by the Indiana Agricultural Experiment Station.

All feeds are required by the Indiana Feedingstuffs law to be officially labeled in order that purchasers may know with some degree of certainty the contents of the feed. To ascertain the correctness of the feed manufacturers' guarantee the state chemist, E. G. Proulx, collected in 1922, 2,945 samples of commercial feeds, a sample for every 115 tons of feed sold during that year. Of the 2,945 samples secured 618 were simply evidence samples, being mostly from shipments previously analyzed and were subjected to microscopic analysis only. The remaining 2,327 samples were analyzed and the analysis compared with the guarantee of the manufacturers. Individual reports of analysis were made to the manufacturer, dealer, and consumer as soon as completed.

The inspection shows that 76 per cent of the samples were up to and better than the guarantee of the manufacturer. Of the 558 samples found incorrectly guaranteed, 373 of them would be classed as different from the guarantee in minor particulars only, and 185 samples would be classed as seriously deficient and not sold in compliance with the feed law.

Shipments found to be seriously deficient were promptly removed from sale and the manufacturer either replaced the shipment with feed up to the guaranteed or else re-labeled the feed with a correct guarantee. Where deficient feed had already been sold, refunds were in most cases made to the dealers and consumers by the manufacturers. Feed is considered seriously deficient as regards chemical analysis when it is either 0.3 per cent or more deficient in crude fat, 1 per cent or more deficient in crude protein, or 1 per cent or more excess crude fibre, or deficient in both crude fat and protein or crude protein and excess fiber, as the case may be.

The ingredients of the feed must also be correctly declared on the official label. One ingredient can not be substituted for another nor can one be left out. In 1922 the inspectors found 195 shipments misbranded as to ingredients. These shipments were promptly removed from sale and the manufacturers required to correctly re-label the feed. It is of the greatest importance that the ingredients of a feed be correctly stated. The feed mixture may be good or practically worthless, depending on the ingredients used in the feed. It is very rare for feed manufacturers to deliberately misrepresent the ingredients of their feed. Usually misbranding is due to carelessness at the feed plant or lack of proper knowledge of correct feed names.

A new feed store has been opened at Danville, Ky., by C. D. Hagan.

The feed business of Frank Reynolds at Ottawa, Kan., has been bought by M. E. Darnell.

A feed, flour and grocery business has been opened at Morrilton, Ark., by Ford Wallace.

A feed business is to be conducted at West Palm Beach, Fla., by Wm. B. Coon of Middletown, N. Y.

Abbott & Fisher, feed and flour dealers of Newkirk, Okla., have dissolved. Mr. Fisher has retired.

L. N. Newton is now in business for himself at Milwaukee, Wis., and will handle a well known feed line.

A feed mill and warehouse are being erected at Rexburg, Idaho, for the Idaho Seed & Produce Company.

H. Johnson has sold his interest in the Johnson Feed & Seed Company at Wahoo, Neb., to Ed. Borreson.

A full line of stock feed, chick and poultry feed, etc., is being carried by the Cavitt Bros. of Woodlawn, Ill.

The business formerly conducted under the name of the Stephenson County Feed Company at Freeport, Ill., is in the future to be conducted as the Dexter Brau Company. C. L. Dexter and H. J. Brau have organized under this name and have bought

out the business of the old company and will handle a full line of feeds, oil meals, tankage, oyster shells and salt.

A feed mill has been installed in the warehouse of C. E. Harris & Son at Corona, Calif., at a cost of \$6,000.

The Sumner Grain & Milling Company of Sumner, Wash., has installed additional feed milling machinery.

The Betta Feed Mills, Inc., have been incorporated at Wilmington, Del., by M. L. Rogers, capitalized at \$200,000.

The Wilbourne Wholesale Flour & Feed Company has been established at Huntsville, Ala., by A. M. Wilbourne.

A one-story building costing \$5,000 is to be erected at Portland, Ore., by A. R. Watson to house his feed business.

A feed business is to be conducted at Richmond, Va., by Harry Comstock, who has bought a building there for that purpose.

A feed store has been opened at Indianapolis, Ind., by H. H. Snapp who will operate as the Snapp Feed Company.

The McConnell Feed Store at Liberty, Mo., has been bought by W. D. Watkins. He will conduct a feed and fuel business there.

A store in which a feed, flour and grocery business is to be conducted, has been opened at Clarksville, Ark., by C. M. Threadgill.

The feed and flour business of B. F. Brauson at Richland, Mo., has been sold to Bohannon & Son. He has retired from business.

The feed mill of the Lynn Bros. at Somerville, Ind., has been bought by E. C. Kelle & Son. They will handle hay, corn, cement, flour, etc.

Improvements are to be made and additional machinery installed for the Chapman-Doake Feed & Milling company of Decatur, Ill., at a cost of \$35,000.

A new feed mill is being installed and other improvements made for the Farmers Co-operative Elevator Company at Stewart, Minn. P. Dilley is manager.

The feed and produce store of P. H. Butler has been bought by the Lamar Bottling Works of Lamar, Mo., which will specialize in poultry and dairy feeds.

The J. M. Sawyer Company has opened a wholesale feed department with offices at Billings, Mont. The company operates chain stores in 12 eastern Montana cities.

Capitalized at \$20,000, the Travis Feed & Grocery Company has been incorporated at Laurel, Miss. T. D. Travis, Sr., and others are interested in this company.

A feed and flour business is to be conducted at Guthrie, Okla., by Frank Gresham who was formerly president of the now defunct Gresham Flour Mills Corporation.

The Gridley Produce & Feed Company of Gridley, Kan., has been bought from H. W. Kurtz by E. H. Kaufman. He has changed the name of the firm to the Gridley Grain & Produce Company.

A L. Smith of Jarvis, Ont., and R. J. Allen of Toronto have organized as the Brant Feed & Seed Company at Brantford, Ont. They bought out the Brant Farmers Co-operative Society, established five years ago.

The capital stock of the Farmers Union Feed Mill & Warehouse at Eugene, Ore., has been increased from \$5,000 to \$15,000; and the company has established produce handling stations at Cottage Grove and Creswell.

N. F. Tidwell has bought a half interest in the Purity Feed Company at El Paso, Texas, with J. C. Hudson and changed the name to the Purity Fuel & Feed Company, Inc. He was formerly with the Community Milling Company.

C. J. Koehler has sold his feed and flour store at Fox River, near Kenosha, Wis., which he conducted for 25 years, to Clarence Haggerty of Gay Mills, Wis., who took charge November 1. Mr. Koehler retains his interest in his business located at Gays Mills.

The Shannon Milling Company, Inc., was recently incorporated at Carthage, N. Y., to deal in feed, seeds and flour. The incorporators of the company, which is capitalized at \$50,000, are William W. Shannon, Williard B. Van Allen and Henry S. Otis. They will soon start operations.

The Moline Feed Store at Neodesha, Kan., is to be operated as the Powell Feed Store. Fred Powell, who, in partnership with C. W. and J. W. Wright, formerly conducted the Moline Feed Store, bought out the interest of the Wright Bros. and changed the name of the firm.

The Fernando Valley Feed & Fuel Company of Van Nuys, Calif., is erecting a warehouse there costing \$10,000. The warehouse will have four bins of 50,000 tons' capacity each giving total capacity of 200,000 tons. Machinery will permit unloading of grain by air suction.

FIELD SEEDS

SEED CORN AND MOISTURE

Seed corn must not contain over 12 per cent moisture if it is to be kept safely during the winter, says A. C. Army of the Minnesota Experiment Station at University Farm, St. Paul, Minn.

Furthermore, there is danger, says Mr. Army, that corn properly matured and once well dried will be placed where it will take up moisture and thus be made unfit for planting another year. After the corn has been well dried down, it should be kept in a dry place until it is needed for planting next spring. If it is kept dry intense cold cannot hurt its germinating power. The thing to do now, therefore, is to get the seed corn ears dried out before freezing weather prevails.

WILL YOU CO-OPERATE?

Seed companies are asked by Miss Ruth E. Evans, vice-president of the Association of Commercial Seed Analysts, to send her a complete set of tags used in labeling seeds and also suggestions which will tend to bring about a more uniform tagging of seeds. The Association hopes through this investigation to arrive at greater uniformity in tagging seeds. When all data has been collected it will be turned over to Curtis Nye Smith, counsel for the seed trade, before it is brought up at the meeting of the Official Seed Analysts in Cincinnati next December. It is hoped that all seedsmen will co-operate by sending sample tags at once to Ruth E. Evans, care of Whitney-Eckstein Seed Company, 599-601 Perry street, Buffalo, N. Y.

ENFORCE SEED LAW

The New Jersey Pure Seed Law requires the labeling of the following types of seeds: Common field crop seeds; mixtures of various crop seeds; lawn grass mixtures; and vegetable seeds. Most of the labeled stock sold in New Jersey has been tested and marked by the wholesaler prior to shipment to the retailer. This has led many retailers to believe that they were not responsible in the matter of labeling. Efforts are now being made to correct this erroneous impression and to enforce more rigorously the seed law. The label statement of guarantees made by the wholesaler in no way eliminates the responsibility of the retail seller as Section 228, Laws of 1916, plainly set forth that the retailer is responsible for all labels which appear on the seed he offers for sale. The penalty is a fine of from \$25 to \$300, and costs.

SEED LAW CONTESTED

A suit has been filed by J. A. Boyce of the J. A. Boyce Seed Company, Olympia, Wash., to test the constitutionality of the Washington 1923 Seed License Law. Under the old law, a flat fee of \$10 per year was charged all dealers in seeds, but an amendment was made by the last legislature placing a \$200 annual license fee upon wholesalers. Two constitutional questions are raised in the complaint: First, that all the seeds handled by the plaintiff are bought outside the state and constitute interstate commerce, that the law is therefore an interference with interstate commerce; second, because the retailer, buying from producers within this state, is exempt, such exemption constitutes class legislation and therefore is in violation of the Constitution. The law recently was held unconstitutional by Judge John M. Wilson of Thurston County on the grounds of discrimination and class legislation, in that co-operative concerns are not required to pay the license and come under provisions of the law.

THE SEED SITUATION

BY B. S. BROWN

The western states from the Pan Handle to Kansas, according to the Peppard Seed Company, have had a long spell of unfavorable weather which has retarded the development of threshing, causing hesitancy and uncertainty among seed handlers and operators. Kansas City seed wholesalers all state that the supply of Red Clover and Blue Grass is short; peas are short; demand for Blue Grass and Red Clover, good for this time of year. Quality of stocks on hand, fair. Trend of wholesale prices, upward on all field seed crops because of fall and anticipated spring shortage.

A. L. Burri, who went in business for himself a year ago at 537 Main street, under the name of the Midwest Seed Company, is developing a wholesale business at the present time. Retail sales comprise the bulk of his business. He was with the Chesmore Seed Company of St. Louis for 20 years. He has been on a crop inspection tour up through the valleys of Nebraska and Colorado and reports that he has found a shortage of growing crops, with the exception of growing corn. The shortage indicates

that prices will be higher in all lines of seeds. The North Platte Valley has been soaked with so much rain, he states, that it has caused the seed crops to be retarded.

SEED ASSOCIATION NEWS

The midwinter meeting of the Wholesale Grass Seed Dealers Association will be held in Chicago the last week in January.

Committee appointments for the year 1923-1924 are as follows: Publicity Committee, chairman, Clifford Corneli; vice-chairman, A. H. Flanigan; other members, C. C. Massie, R. S. Sheldon, J. G. Purvis; Membership Committee, chairman, A. E. Reynolds; other members, E. F. Mangelsdorf, Robt. S. McCullough; Trade Rules Committee, chairman, F. P. Armstrong; other members, M. H. Duryea, A. F. Mangelsdorf, D. A. Parks, J. L. Peppard; Arbitration Committee, chairman, L. L. McCullough; other members, J. J. Buffington, Clifford Corneli, A. H. Flanigan, R. S. Sheldon; Legislative Committee, chairman, W. G. Scarlett; other members, C. D. Boyles, J. Wm. Jefferson, P. V. Kelly, C. C. Massie; Grievance Committee, chairman, Curtis Nye Smith; other members, C. D. Boyles, H. S. Patrick, H. E. Conklin, L. L. McCullough, C. A. Neal, Hugh Teweles, Owen T. Watts.

NEW SEED TRADEMARKS

The following new seed trademark was recently published in the *Official Gazette*, published by the United States Patent Office: "Barden's Wonder

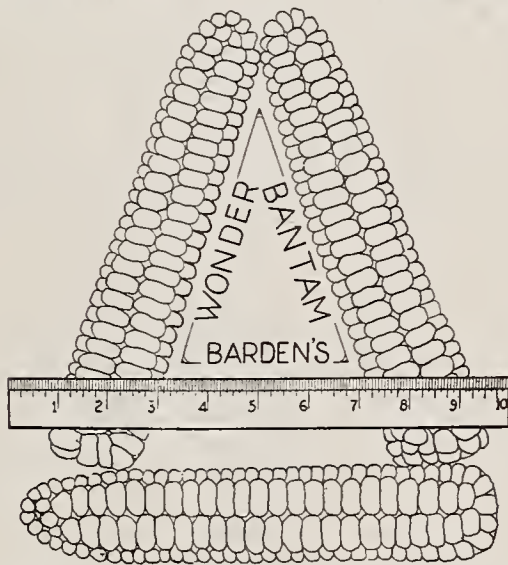

Bantam" seed corn. Clifford A. Barden, Oberlin and Wakeman, Ohio. Filed June 13, 1923. Serial No. 181,928.

CANADIAN SEED GRADING BILL IN EFFECT

On October 1 the bill respecting the testing, inspection and sale of seeds in Canada was brought into effect by an order-in-council.

The grading has to do with the grading and specification of grades of seeds placed on the markets. Thus, if seeds prove not up to a specified quality, the purchaser can get redress. An important provision of the legislation has to do with keeping grass and Clover seed free from seeds of noxious weeds.

It is provided that seed packets shall bear (a) the name and address of the sellers, (b) the name of the kind of variety, (c) the year in which the sealed container was filled, (d) the percentage of germination when such germination is below the minimum percentage of germination prescribed by regulation for seed of the kind.

The bill also provided for the registration, through the Canadian Council of Horticulture, of newly discovered varieties of agricultural or garden vegetable seeds or plants.

Under section 12 of the act an advisory board has been appointed consisting of seedsmen and seed growers to assist the Seed Commissioner, who is chairman, in the administration of the act.

CLOVER LOWER

Southworth & Co. of Toledo, under date of November 10, say: Clover ruled weak and sharply lower this week on liquidation by longs and some fresh hedging sales against purchases, both domestic and foreign seed. Resting orders absorbing the offerings on the scale down. Also some short covering. Cash seed lost its premium. There is a large open interest in December. Will longs be willing to accept deliveries when tendered on con-

tracts, or will many of them liquidate their holdings? Some foreign seed has arrived, and understand large quantities are to be shipped to apply on nearby and deferred sales. Country receipts of Clover continue light. Receipts this week 429 bags, shipments 290.

A French dealer writes—"There is a good demand for Clover, but holders ask too high prices. Offerings are light. America wants to buy Clover lower than offered. Two-thirds of our crop has been sold. European requirements not yet covered, but show no disposition to buy."

The November Government figures place the entire Clover crop at 1,121,000 bushels against 1,251,000 last month. The report shows a decrease of 131,000 bushels under last month.

Alsike slightly lower. Timothy firm. Trade light. New York reports exports 700 bags of Timothy.

MILWAUKEE SEED MARKET UNSETTLED

BY C. O. SKINROOD

The short crop of seeds for the past season and the slow marketing are reflected in the figures on seed receipts at Milwaukee for the month of October. This is an early month for seed trade to develop, but it usually gives some sign as to what the season will bring forth.

Receipts of Clover seed at Milwaukee for the past month were according to official reports by the railroads, only 304,223 pounds as compared with receipts of 500,231 pounds for the corresponding month a year ago. The receipts of Timothy seed for the past month were 755,500 pounds as compared with receipts of 1,050,000 pounds for October, 1922.

Shipments of seeds from Milwaukee for the past month were also on a remarkably large scale, especially when set alongside of the small receipts for the past month. The shipments of Clover seed from Milwaukee for the month of October past were 753,425 pounds as compared with shipments of 409,535 pounds for the corresponding month of last year. The shipments of Timothy seed from Milwaukee for the past month were 724,612 pounds as compared with shipments of only 160,065 pounds for the corresponding month of last year.

Comparing receipts and shipments of Clover seed at Milwaukee for the past month, the receipts were 300,000 pounds in round numbers and shipments 750,000 pounds approximately, so that shipments were much more than twice as large as the receipts. Comparing receipts and shipments of Timothy seed for the past month, the receipts were 750,000 pounds in round numbers, while the shipments were 725,000 pounds approximately. Receipts were practically offset by shipments during October, 1923, the difference between the two figures being negligible.

The receipts of flax seed at Milwaukee for the past month reached a high figure with 120,650 bushels as compared with receipts of only 71,735 bushels for the corresponding month a year ago. The shipments of flax seed are almost always negligible, the figure for the past month being zero, while the shipments for the corresponding month of last year were 9,554 pounds. The flax seed received at Milwaukee is practically all used for local consumption.

The small supply of Clover seed in Wisconsin is helping to bring better prices for Clover, according to reports from numerous country districts. The pasturage of second crop Clover and its frequent cutting for hay instead of for seeds made a small crop and correspondingly improved prices. Prices to growers last month in northeastern Wisconsin were around \$20 as compared with an average last year of \$15.75 for the same period.

In western counties, prices are reported around \$21 for last month as compared with \$16 for the corresponding month a year ago. In the southern sections of the state Clover seed was reported as selling in the country last month at approximately \$20 as compared with \$17 for the corresponding month a year ago. Prices are apparently 20 to 30 per cent better than last year from the standpoint of Wisconsin farmers. The heaviest marketing has been reported for the northeastern sections of the state. On the other hand a good percentage are apparently holding for better prices even though they are getting far better returns per pound than last year.

Reports indicate that foreign seed is coming in quite heavily because of the shortage in the home crop. Shipments are reported from France and Belgium, also a small amount from Germany and from some other European countries.

If Clover seed soars to very high prices, predictions are made in the state that the crop will be cut down, as farmers dislike Clover crop failures and losses, even with moderately priced seed. It is also predicted that many farmers will turn much more largely to Alfalfa when it comes time to buy seed supplies for the season. A move is also on foot to induce Wisconsin farmers to use more lime and marl and thus materially assure the success of their Clover and Alfalfa plantings. The College of Agriculture is urging the use of lime more and more to stimulate forage crop growth.

A. L. Stone of the Wisconsin Department of Ag-

riculture has sent out a call to all farmers and dealers expecting to sell farm seeds in Wisconsin to get their tests made early and their labels prepared now so as to avoid delay. He calls attention to the fact that all dealers offering agricultural seeds for sale for seeding must attach to each package weighing a pound or more the name and kind of seed; the name and address of the seller; the percentage of pure seed; the percentage of the seed which will grow; the place where grown if the seed is corn, Alfalfa or cereals.

Mr. Stone also declares that the following weed seeds are noxious: Canada thistle; quack grass; Clover, Alfalfa and field dodders; wild and Indian mustard; ox eyed daisy; wild oats; corn cockle; snapdragon, perennial sow thistle; and buckhorn or English plantain.

One of these seeds to 3,000,000 or less of the crop seeds makes the seed unsaleable in Wisconsin except in the case of buckhorn, which is one seed to 1,000. The presence of one noxious weed to more than 3,000 of the crop seeds must be mentioned on the label. Mr. Stone points out further that these provisions apply to every man offering seed for sale for seeding purposes, farmer and professional dealer, alike. Farmers may sell seed to dealers in bulk without the label however.

Any one may test his own seed Mr. Stone adds, but will be held responsible for the accuracy of his tests. Should the inspector not find the seeds as represented, the seller is liable to prosecution and fine, he asserts. The samples of seeds for testing should be sent to the State Seed Inspector, at the Agronomy Building at Madison, Wis. Mr. Stone explains, and the fee for testing, 25 cents as fixed by law, must accompany the sample. Mr. Stone also warns that the seeds must be thoroughly mixed and the samples as given must be thoroughly representative of the entire lot. He believes that the value of the test rests largely with the care in which the sample is taken and that such samples should range from two to four ounces. As for the germination test, Mr. Stone points out that it takes six days for Clover, Alfalfa and corn, eight days for Timothy seed and 28 days for Bluegrass seed. The earlier seed tests are made the better, Mr. Stone concludes in his instructions to the seed trade of the state.

The corrected returns from the Wisconsin Department of Agriculture show that the Clover seed crop of Wisconsin was cut down 31 per cent below the total for last year. The Department says the acreage cut for Clover was small and that the yields were likewise light, due to the adverse weather conditions for the season.

Corrected estimates of the Alfalfa hay yield of the state show a return of 307,000 tons. The acreage of Alfalfa in the state in 1923 is estimated at 40 per cent more than in 1922 and the actual yield of Alfalfa for the season was fixed at almost 50 per cent higher than last year. This in face of a short hay crop in many sections of the state. The yield of Alfalfa, while large, it is estimated is sufficient to feed only 12 per cent of the cows of the state. Hence, there is room yet to increase Alfalfa acreage and provide feed for the other 88 per cent of the cows in the state. The state therefore is supplying only one-eighth of its necessary requirements of Alfalfa. A very large sowing of Alfalfa is expected for the spring of 1924, according to local seedsmen, who report the crop growing in popularity by leaps and bounds in many counties.

The Courteen Seed Company says the seed market is unsettled and that it is somewhat difficult to gauge conditions at this time, so that it has no report to make on the seed market until next month.

The official report of the seed market by the Milwaukee Chamber of Commerce for last month says that the seed market was strong, the supplies were small and the Clover market went up from \$3 to \$4 for the Red, while White Clover seed was largely nominal, flax gained 24 cents a bushel and Timothy advanced all the way from 50 to 75 cents.

The report quotes Red Clover as ranging from \$15 to \$23; Alsike is given a range of \$10 to \$15; No. 1 Northwestern flax sold during the month from \$2.30 to \$2.56; poor to fair Timothy ruled at \$5.50 to \$6.75, the good to choice was quoted at \$6.25 to \$7.25 and the fancy was quoted from \$7.25 to \$8.

The L. Teweles Seed Company says the seed trade at the present time is fair and that stocks are steadily increasing as expected for this time of the year. The company asserts that only a small percentage of the farmers are holding for higher prices for their seeds and that the great bulk of the crop will be sold within the next 30 days.

The high prices now ruling for the various kind of seeds are not expected to discourage the farmers from planting liberally next spring and fulfilling their normal requirements. The company says that only the war prices of 50 to 70 cents a pound were so high that planting of grass seeds was cut down materially. Since the actual increased cost of seeds at present high prices, so-called, is only a few cents an acre, the added cost is not expected to cut much figure with those who really need and want seeds.

The Teweles company says it is hard to predict

the future trend of the market, but that an advance is hoped for in view of the large supplies of seeds now on hand. Red Clover seed is quoted by the company as ranging from \$20 to \$22 for the best grades. The Timothy market is given a range of \$7 to \$7.75. The Alsike market is quoted from \$12 to \$14. Alfalfa is reported as unchanged and ruling from \$20 to \$22. The White Clover market is quoted from \$35 to \$40. In general the company looks for a good seed trade during the winter as conditions are all favorable for a strong buying demand, despite the somewhat high range of present prices.

The North American Seed Company is highly optimistic as to the seed trade outlook for the coming winter and spring. The company says that the demand for seeds was exceptionally good all summer and fall and this gives promise of an excellent trade in seeds in the next few months.

The company finds that the farmers are in good financial condition, in fact, the dairy districts of the state are probably the best fixed farmers in the entire United States. With this ability to buy seeds the North American Company says there can no question about the continuation of the good demand. It is not believed that the high prices will have any bad effect in discouraging the planting of grass seeds.

The North American says receipts of seeds have been good, the farmers have been selling their holdings freely, outside of a small percentage who always hold back until spring before they sell. The company reports that the supply of seeds from Wisconsin may be larger than last year, while the crop shortage generally reported applies mostly to states other than Wisconsin. The Alsike crop, however, is reported as very light.

The company quotes the seed market as steady to firm and the belief is held that the present scale of quotations is well warranted by the conditions that exist, so that quotations are in no sense inflated.

The North American quotes Red Clover from \$21 to \$23. Timothy is said to be ruling from \$8 to \$8.50. Alsike is given a range of \$14 to \$16. White Clover is quoted at \$35 to \$45 and Alfalfa is selling from \$20 to \$22.

The North American points also to the large amount of Clover area which had frozen out last year which must be replenished in this dairy state, where much feed is needed, and this too will help to assure an excellent demand for seeds throughout the season.

SEEDS GENERALLY FIRM IN NEW YORK MARKET

BY C. K. TRAFTON

During the month under review it has been largely a matter of "between seasons" in the New York seed market, with the fall demand satisfied and with plenty of time ahead to prepare for the "spring drive." Hence, while there have been sporadic instances of activity in a few varieties, there has been no general animation. Consequently there have been no particularly interesting developments anent prices, the changes in most cases being small and traceable to small "dickering" operations. In the main, however, the tone has continued firm, as arrivals as a rule have been small, and therefore stocks are generally lighter than they were a month ago. In the export field, also, it has been mainly a case of "between seasons," but some business has been accomplished and the receipt of additional inquiries from abroad creates the belief that larger dealings may soon ensue. Shipments to Europe were on a larger scale, including: 4,673 bags of Timothy against 1,900 last month; 1,118 bags of Bluegrass against 285 last month; 790 bags of Redtop against 715 last month; 307 bags of Meadow Fescue against nil last month; and 200 bags of Alsike, or the same as last month.

Red Clover has been quiet on the spot and the tone in the main has been slightly easier, although no business has been reported at noteworthy concessions. Still the top of the market is now about 23 cents, against 24½ cents at one time last month. This was traceable largely to a growing conviction that a more cautious buying policy would bring out more attractive offers from abroad. Having recently bought 15,000 to 20,000 bags, mostly in France, at from 19 to 22 cents duty-paid, buyers were evidently more willing to hold aloof for a while, being impressed by more reports of large European crops with estimates of the exportable surplus ranging from 65,000 to 200,000 bags. One European authority stated that Europe had enough seed to supply all our needs and that the future course of prices depended largely on the demand from this side. It was the great number of inquiries from the United States that started European markets from 2 to 3 cents higher than they should have been. Prices are gradually working back, latest offers being at 20½ cents duty-paid, whereas some had been as high as 24 cents previously. The arrivals were 4,725 bags, against 500 during September. This month's total included 500 bags from Chile.

Alfalfa was slightly easier on spot at one time, but later a firmer tone developed and the market

is now 20½ to 21½ cents, or from ½ to 1 cent higher than a month ago. Although the fall demand was supposed to be over, buyers showed fair interest at times, and they generally found offerings of choice seed small. The arrivals were slightly larger—11,965 bags, against 7,420 last month one shipment of 3,300 bags on the steamer *Southern Cross* was seriously damaged by water; almost a total loss. In some quarters an easier tone was expected because of the larger movement of domestic seed, but up to the present the indications are that this will not be cheaply offered; possibly in the neighborhood of 21 cents at eastern points. Moreover, it is generally expected that the winter demand will be good, and in the meantime the conviction is growing that no help can be expected from Argentina. In fact, it is generally accepted that the crop there has been sold. For what little choice seed is available as much as 19½ cents duty-paid has been asked, and even for seed containing dodder holders want from 18½ to 19 cents. Seed containing a large amount of dodder was available at 17 to 17½ cents and some shippers were said to be buying this for delivery here, although it seemed certain that it would not be allowed to enter. Other shippers were paying fair premiums to buy back their contracts. As a consequence more interest was shown in French seed, fair sales being reported at 17 to 18 cents duty-paid. Some of this seed was said to be only 99 per cent pure, containing buckhorn and Red Clover, but other lots were of choice quality. No interest was shown in Italian seed offered at 19 cents duty-paid as it was felt that prices would have to be much lower in order to offset the previous Government opposition to this variety. The arrivals included 250 bags from South Africa.

Crimson Clover has declined about ½ cent during the month as demand has been dull, the majority of buyers refusing to anticipate spring needs, believing that liberal supplies in Europe would result in offerings at lower levels. There was a little buying for winter carry-over when France was offering at 8 cents duty-paid, but this interest faded as shippers showed no disposition to offer concessions. In fact, some advanced their price ¼ cent. Arrivals were only 630 bags, against 3,440 during September. Spot prices now range from 8 to 8½ cents.

White Clover continued as the weakest item on the list, the spot quotation of 50 to 51 cents marking another 2 cents loss for the month. Arrivals were smaller, 565 bags, against 670 during September, but demand was dull as buyers were anticipating cheaper offerings from abroad. The foreign situation has been somewhat unsettled. More claims were heard regarding the scarcity of choice seed in Germany and holders asked 43 to 44 cents duty-paid. On the other hand, there seemed to be more pressure to sell poorer quality seed, some containing Alsike and Red Clover being offered as low as 35 cents.

Rye Grass was wanted for lawn grass mixtures by buyers in the extreme south early in the month and with stocks light prices gained about ½ cent, or to 11 to 11¼ cents. Later the demand was less active, but the market remained firm as moderate arrivals—about 1,755 bags, compared with 1,670 in September were well absorbed. Moreover, reports were received of a delayed new crop movement in Ireland because of wet weather. As a consequence shippers raised their prices ¾ to 1¼ cents, or to a duty-paid basis of 10¾ cents for Italian, 11 cents for Perennial, and 12 cents for Pacey's.

Orchard Grass has been dull but firm on spot, being quoted at 17½ to 18½ cents, or about ½ cent higher. Following sales during September at 17½ to 17¾ cents duty-paid, Danish shippers raised the price to 19 cents, and in some cases to 21 cents, and hence further business was impossible. Arrivals were only 600 bags, against 1,500 during September.

Alsike has been dull but firm at last month's top price of 17½ cents. There has been no pressure to sell owing to the big discount compared with Red Clover. Nevertheless, the price difference has not stimulated much demand for cheap grades.

Timothy has also been dull but firm at last month's top price of 8¾ cents, evidently owing to the larger exports and also to the steadiness in the interior in the face of the customary quietude between the ending of the fall season and the first signs of spring demand.

Fescue has been quiet and nominally unchanged on spot as old orders readily absorbed additional arrivals of 1,560 bags, against about 2,590 during September. Hence stocks remain meager. No interest was shown in offerings for shipment from New Zealand at 24 cents duty-paid, compared with 24.60 cents a month ago.

Hairy Vetch has been slow but steady on spot owing to small arrivals. Moreover, European shippers raised the price from 10 to 10½ @ 11 cents duty-paid.

Spring Vetch has been moving in a moderate way at 3.90 and 4 cents duty-paid, with some shippers asking up to 4½ cents. There have been moderate arrivals and the seed is said to be the best seen in four years.

Kentucky Bluegrass has been dull and is quoted

nominally unchanged at 25½ to 27 cents. In spite of claims that foreigners would not buy at the prices asked by the western pools it was noted that exports were materially larger.

Fancy Redtop has been slow and about ½ cent lower at 14½ to 15½ cents.

Rapeseed was in fairly good demand early in the month and as additional moderate arrivals were well absorbed the market was steady at 5½ cents, with some choice Dutch seed held at 6¼ cents. Later demand was less active and seed became available at 5¼ cents. In fact, it was believed that one small lot on dock could have been picked up at 4½ or 4¾ cents ex-dock. The easier tone was partly in keeping with lower offerings from Holland. Early in the month a fair trade was reported at 4¾@5 cents, holders offering in a small way only and claiming that most of the crop was still held by growers. Later, with the decline in Dutch exchange offers were received at 4½@4¾ cents. Japanese seed was offered early at 4¾@5 cents and later at 4.65 cents. The Pacific Coast reported offers at 4¾ cents c. i. f. French seed likewise eased from 4.85 to 4½ cents. Some of this seed was said to be musty. Arrivals were about 4,470 bags, including 936 Winter Rape from Germany, against 5,165 during September. Argentine Bird Rape has been inactive at 3.50 to 3.60 cents; arrivals 260 bags.

Sunflower seed of choice quality has been firm owing to the unsatisfactory quality of much of the new domestic seed arriving. Complaint was made of light weight owing to small kernels and of a large proportion of foreign matter and of stained and wormy seed. Such seed was offered at as low as 4.85 cents, eastern points, whereas the small percentage of choice seed was held at 5.45 cents. A moderate quantity was received from Argentina and some of this was rather difficult to move at 5¼ cents for good seed and 5 cents for stained. Quotations from Argentina were without noteworthy change, choice seed being offered at 4.60 to 4.70 cents duty-paid, and f. a. q. at 4.45@4.50 cents. Danubian seed has been firm on spot at 5¾ to 6¼ cents. Early in the month fair sales were made for shipment at 5¾ to 5½ cents duty-paid, but later shippers claimed that the small remainder of the old crop was being sold to better advantage in Europe, and hence some advanced the price to 5¾ cents. Dutch seed was quoted at 5½ cents, both on spot and for shipment. Total arrivals were 2,335 bags, against 590 in September.

Canary seed has advanced about ¼ cent, or to 5¼ cents on spot, owing to much smaller arrivals, only 2,070 bags, against 8,730 during September. This served to offset cheaper offerings from Morocco, based on the drop in exchange rates. Sales were reported at as low as 4.70 cents duty-paid and even at slightly less, compared with sales at 5 to 5.10 cents last month. Although it was stated that only about 200 tons remained for export, little disposition was shown to do any speculative buying. Argentine shippers reported good sales to Brazil and hence little was heard of offers, although some named a price of 5¼ cents duty-paid early in the month. Offerings of Dutch seed declined with the Morocco, but buyers showed no interest.

Millet has been in slow demand on spot and owing to the big crop yellow hog has declined from 3½ to 3¾ cents. Owing to the duty of one cent, foreign shippers have been unable to offer on an attractive basis. Levant millet and Manchurian red has been offered at 3½ cents duty-paid without leading to business. The latter is quoted at the same price on spot. Morocco seed was offered at 3@3¼ cents duty-paid and about 50 tons which arrived were said to be available on spot at 3 cents, although it was claimed that this price meant a loss of ½ cent to the seller; arrivals were 265 bags.

Hempseed has been irregular but the ruling tone has been firmer owing to meager stocks and higher prices in Manchuria. Because of the meager supply here holders at the outset endeavored to secure 5 cents, but finding that buyers had obtained seed in Philadelphia at 4.35 cents, some of them came down to 4½ cents, and business was reported even as low as 4¼ cents. In the meantime the market for shipment advanced to 3¼ cents after sales early in the month at 3 cents. The local market responded by going to 4¾ cents, although a little was said to be available at 4.60; arrivals were 312 bags.

China White Peas were in good demand on spot early in the month and with stocks light holders were firm at 4½ cents and refused bids of 4¼ cents. Later the market declined to 4.20@4.30 cents owing to the easier domestic situation, there being talk of Michigan offerings at below 4¼ cents; while Canadian seed was offered at 3@3¼ cents f. o. b. Meanwhile, shippers advanced their price on new crop to 4¾ cents duty-paid.

The B. B. Kirkland Seed Company of Columbia, S. C., has remodeled its plant by adding another story to the building and installing an electric elevator. The company handles a full line of poultry, dairy and stock feeds in addition to field and garden seeds.

A seed store has been opened at Los Angeles, Calif., by the Market Seed Company.

The seed business of Ingram & Henderson at Bell, Calif., has been discontinued.

A seed store is to be opened by R. C. & E. L. Guy at Chester, S. C., capitalized at \$2,000.

A new seed store is being erected at Wauchula, Fla., by the Kilgore Seed Company.

The New York branch of Ingemann-Christenson & Co., seed dealers, has been closed.

The Bowden Seed Company has been succeeded at Ocala, Fla., by the Marion Seed Company.

New quarters are to be occupied by November 1 by the Satex Seed Company of San Antonio, Texas.

A cleaning house has been opened at Duchesne, Utah, by the J. G. Peppard Seed Company of Kansas City.

L. R. Collins is now in the seed business at Marietta, Ga., and is operating as the Collins Seed Store.

The Wade Produce Company of Trenton, Tenn., is succeeded in business by the Wade-Cooper Produce Company.

A store in which seeds, feed and groceries will be carried on is to be opened by C. S. Lowthorp & Son of Hope, Ark.

A two-story building is being erected at Seattle, Wash., by W. H. Henwood, who conducts a seed and feed business there.

An additional two-story seed warehouse has been completed at Wethersfield, Conn., for the Charles C. Hart Seed Company.

J. F. Haid and associates have incorporated at Vicksburg, Miss., as the Vicksburg Seed Company, capitalized at \$10,000.

A. J. Poorman & Co., has been incorporated at Fairfield, Ill. The company purchased six improved cleaners for the business.

The Farmers Union Supply Company of Augusta, Ky., has been incorporated and will conduct a seed, feed and implement business.

New machinery has been installed by W. G. Sherman Seed & Grain Company of Riverton, Iowa, which more than doubles its handling capacity.

The Courteen Seed Company of Milwaukee, Wis., has named G. Bradley of Twin Falls, Idaho, as agent at Boise, Idaho, replacing C. I. Hahn of Twin Falls.

H. V. Harden, formerly with the Iowa Seed Company, in the wholesale department and later as receiver for the company, is now with the Standard Seed Company of Des Moines, Iowa, and will travel for them in the western half of the State of Iowa.

Capitalized at \$50,000, the Garvey Seed Company has been incorporated at Salt Lake City, Utah, to do a general brokage and seed storage business.

The officers are G. L. Bryant, president; T. F. Bryant, vice-president, and G. H. Parkins, secretary and treasurer.

The Trimble-Lyon Seed Company of Moultrie, Ga., a well known seed and feed firm of that territory, is now located in a new building.

The seed and implement business of the Hafendorfer Thornton Company at Owensboro, Ky., is now conducted by the A. Bresler & Son Company.

C. A. Ranney is now with the Wertz Seed Company of Sioux City, Iowa. He had been with the Alhert Dickinson Company at Minneapolis for 18 years.

Richard S. Orr is now connected with the Van Antwerp Seed Store at Mobile, Ala. He was formerly manager of the William Seed Company of Norfolk, Va.

The Vicksburg Seed Company has been incorporated at Vicksburg, Miss., to conduct a wholesale and retail business in field, flower and garden seeds and poultry supplies.

To conduct a seed and implement business, the Farmers Supply & Seed Company has been incorporated at Greenville, S. C., capitalized at \$20,000. C. C. Hindman is president.

A. J. Sedlock is now affiliated with the Standard Seed Company of Kansas City, Mo. He was connected with the J. G. Peppard Seed Company of Kansas City for 15 years.

Capitalized at \$10,000, the N. R. Van Atta Seed Company has been incorporated at Cincinnati, Ohio. E. D. Schorr, Roy Monogue, G. Renner, A. J. Renner and C. Embshoff are interested.

A new and up-to-date plant has been built for the J. Oliver Johnson, Inc., old time seedsmen of Chicago, and seed cleaning, handling storing and bagging equipment has been installed.

Improvements are being made to the plant of Ed F. Mangelsdorf & Brother of St. Louis, Mo. Labor saving machinery, a large Monitor cleaning mill, and additional storage tanks will add to the efficiency of the plant.

Henry McKnight has bought the business of the Gittings Seed Store of Neosha, Mo. Mr. McKnight for 12 years traveled for the Leonard Seed Company. Mr. Gettings retains the building in which the business is located.

A wholesale and retail business is to be conducted at Leesburg, Fla., for Haile & Co., seedsmen of Monticello and Cordele, Ga. The company is building a new house there and will establish headquarters during November.

John E. W. Tracy has resigned his position with the United States Department of Agriculture and is now associated with the D. Landreth Seed Company of Bristol, Pa. He will act as manager of the Landreth Bloomsdale trial grounds, seed crop breeder, and inspector of contract crops.

The Mangelsdorf Seed Co.

Sweet Clover, Alfalfa,
Soudan Grass, Millet, Rape.

ATCHISON

KANSAS

North American Seed Co.

Wholesale Grass and Field Seeds

Milwaukee, Wis.

"THE HOUSE OF QUALITY"

COW PEAS SOY BEANS SUDAN
MILLET CANE

Agricultural Seed Company

230 Biddle St.,

St. Louis, Mo.

Exporters

Importers

Nungesser-Dickinson Seed Co.

NEW YORK, N. Y.

Wholesale Seed Merchants

Buyers and Sellers

Timothy, Red, White, Alsike and Alfalfa,
Clovers, Redtop and Millet Seeds

SEEDS

BETTER SEEDS; BETTER CROPS

CHAS. E. PRUNTY

7 South Main Str. SAINT LOUIS



BUYERS—SELLERS, FIELD SEEDS

ED. F. MANGELSDORF & BRO.

Wholesale Field Seeds

First and Victor Sts., St. Louis, Mo.

WHITNEY-ECKSTEIN SEED CO.

Wholesale Seed Merchants

Correspondence Invited

BUFFALO, N. Y.

COAL

COAL ASSOCIATION APPOINTMENTS

The National Retail Coal Merchants Association has appointed the following named members to represent it on the proposed advisory committee to the Coal Division, Department of Commerce:

S. B. Crowell, vice-president of the George B. Newton Coal Company, Philadelphia, Pa.; M. E. Keig, vice-president, Consumers Coal Company, Chicago, Ill.; Roderick Stephens, of the Stephens Fuel Company, New York City.

MINE OWNERS CITE UNION EVILS

A special committee composed of bituminous operators, now co-operating with the United States Coal Commission in its endeavors to bring to some settlement the troubled condition in the coal industry, says that complete unionization of the coal miners would be ruinous.

"A general strike of the union miners in the United States last year, lasting five months, caused suffering to the people of the United States and a crippling of industry which was relieved only by enlarged emergency production of bituminous coal from the non-union fields. Before the end of the strike the non-union mines were producing more than half of the usual weekly supply of soft coal required by the country.

"The leaders of the United Mine Workers of America caused the repeated breakdown of the conferences with the anthracite operators at Atlantic City, and threatened a bituminous strike, despite the existence of contract running until April 1, 1924, when the plan to furnish soft coal as an anthracite substitute was put forward.

"In the face of such facts, there is the public statement made to the United States Coal Commission early in November last by the officials of the United Mine Workers of America, in a formal communication, declaring that 'The ultimate solution for the strike problem in the coal mining industry lies in the complete unionization of the entire industry.'

"The salvation of America's industry last year was that the labor monopoly of the United Mine Workers of America was not complete, and that coal was produced despite the spending of millions of dollars, collected through the 'check-off' system, in violent efforts to prevent open shop operators from producing coal. Should the despotic power of the officials of the United Mine Workers extend to the whole coal mining industry, all of America would be in the power and at the mercy of this single labor organization."

EXHAUSTIVE REPORT ON COAL AND TRANSPORTATION

The American Railway Association Conference Committee has made an exhaustive study of the various factors entering into the transportation of coal and in its final report submitted to the United Coal Commission gives much valuable information and two reasonable suggestions for the solution of the coal problems in this country. The Committee suggests that there are two fundamental conditions which the public must establish before the problem of distributing coal will be solved. These are: Fair treatment to the railroads under which they will be permitted to earn a fair return upon the value of their property fairly ascertained; and freedom from strikes, both in the coal and railroad industry, so that these two essential businesses may function without disturbing interruptions.

The report discusses growth of railway traffic, growth of coal and coke traffic and other traffic handled in open top cars, growth of railway facilities, relation of transportation growth to the movement of coal, economic effect and cost of equipping railroads with facilities necessary to move peak production of coal, conservation of fuel, transportation of coal by water, seasonal movements of traffic, extent and causes of so-called coal car shortages, effect of labor disturbances, mine ratings, demurrage, pooling coal and structure of coal rates.

The report shows that in 1900 total net tons of revenue freight originating, all classes amounted to 583,351,351, while in 1921 the total was 1,015,852,971 net tons.

Originating coal and coke traffic in 1900 totaled 202,606,506 net tons, while in 1921 the total was 376,220,668. In 1920 the total was 489,344,503 net tons.

Reflecting growth of railway facilities the report shows that investment in road and equipment as of June 30, 1900, was \$10,263,313,400, and the investment per mile of road, \$56,566.81, while as of December 31, 1921, the investment in road and equipment was \$20,338,597,657, averaging per mile of road, \$84,253.05.

The committee submitted a chart which it said

showed that the alleged shortage was not the direct result of transportation shortage, but of other causes. It said a careful study indicated that the two periods of greatest coal car shortage had been preceded by and were the principal result of labor disturbances in the coal mining industry, and that freedom from labor disturbances would result in a more uniform production, enabling the railroads to supply better the mines with the required number of cars.

Discussing the economic effect and cost to equip railroads with cars and locomotives to move peak production of all coal mines, the report shows that in 1920 the bituminous coal mines ordered 16,357,514 cars which, on an average loading of 50 tons per car, would have transported 817,876,000 tons. The actual production was 568,667,000 tons. The tonnage for which cars were ordered was therefore in excess of production by 249,209,000 tons or by 44 per cent, the report shows. The Committee estimates that 232,140 additional cars would have been required to handle the excess and that at \$1,700 per car the cost of the additional equipment would have been \$395,000,000. Additional locomotives would have cost \$392,000,000. Additional facilities necessary to move the excess would have brought the total additional cost to not less than two billion dollars, the committee says. The result from such over-development in the railway industry to handle peak loads would be surplus railway investment, surplus railway labor and part time employment, increased railway wages and increased freight rates, the committee says.

The committee says 520,000,000 net tons would seem to be a liberal measure of the country's annual needs for soft coal, or 10,000,000 net tons per week.

HIGH WAGES BLAMED

Dr. F. C. Honnold of the Honnold Coal Bureau says that because of high wages paid at union mines, Illinois is losing its coal markets to non-union operators.

"The future production prospect of Illinois is not alluring," said Dr. Honnold. "Unless there shall be a wage reduction at the expiration of the present wage scale, those markets into which the bulk of Illinois coal moves will be still more extensively supplied by coal moving from non-union districts. There will be an immediate repetition of the experience of the summers of 1921, 1922 and earlier years.

"Non-union coal operators and their miners will continue to secure the greatest possible amount of working time that car supply will permit. On the basis of mutuality of interest between non-union operators and miners, wages can and will be reduced.

"Through price reduction there will be increased

demand for and output of non-union coal. Both this reduction in cost and consequent lower price to the public will come about as the result of fuller time operation of non-union mines.

"The non-union miners, meanwhile, will profit through the greater amount of work secured and will, as has frequently happened during the past 10 years, make a larger annual income than the union miners in Illinois, into whose market the non-union coal finds movement.

"Only to the extent that geographical location and consequent lower freight rate may protect them, may the Illinois miners and operators find it possible to move Illinois coal into the common markets.

"Past experience, both prior to the war and since, particularly in 1914, 1915, 1916, 1919, 1921 and 1922, has shown clearly and conclusively, in these six out of the last 12 years, that geographical location and freight rate will not permit, justify or make possible a much higher wage rate than is paid in other competing fields, even though such competing fields are well removed.

"The miners' leaders do not or will not see this, or if so will not acknowledge it."

PUBLIC SHOULD AROUSE ITSELF

If the public would rouse itself from its lethargy in regard to the coal question, much would and could be done towards curbing those decidedly unfavorable conditions which now exist, says M. C. Cutting in an article, entitled "The Trouble with Anthracite," published in a recent issue of *The Farmer* of St. Paul. Mr. Cutting said, in part:

"The United States Coal Commission has recommended Government regulation and public accounting for coal land-owners and coal operators, and a graded excess profits tax on royalties and mining profits.

"The Commission has recommended legislation to authorize the President of the United States to declare a national emergency whenever a suspension of mining takes place and to take over and operate the mines.

"It has recommended a reduction of freight rates, a uniform standard ton, and Government inspection of quality at the mines.

"It has recommended various improvements in the miners' working agreement, better methods of adjusting or arbitrating contract grievances and, most important of all, that the agreement shall provide penalties for breach of contract and shall provide the methods by which such penalties can be enforced.

"What is needed most, however, is a little real temper on the part of the long-suffering and too patient public. What is needed is an insistent public demand that legislation to regulate profits and to curb the arrogant dictatorship of the union mine labor shall be passed.

"What is needed is a little more knowledge that anthracite is not the only kind of coal, a little more co-operation in buying during the summer season, and a whole lot of independence in seeking and using substitutes, such as soft coal and oil.

"When the public gets busy, and only then, our domestic fuel problem will be solved. And there is a widespread suspicion that the public is going to



WHEN YOU BUY COAL Consider these facts

Since 1883 we have been supplying carload coal buyers.

For forty years the name PEABODY has stood for Good Coal and Efficient Service.

Today PEABODY is operating 44 mines in 12 districts with daily capacity of 86,000 tons and shipping coal to the dealers and industries of 48 states and British Columbia.

We invite your inquiries when in need of coal.

PEABODY COAL COMPANY

CHICAGO

Cincinnati
Springfield
Saint Louis

Kansas City
Omaha

Deadwood, S. D.
Kleenburn, Wyo.
Spokane, Wash.

LARGEST PRODUCERS AND DISTRIBUTORS OF COAL IN AMERICA

get so busy this winter, that Congress will be forced to legislate some of the excess profits and needless shortages out of the anthracite industry, and legislate into it some decent business practices and some respect for the public interest."

COMMISSION ACCUSES COAL WHOLE-SALER

The United States Coal Commission in a recent report made on the wholesale and retail coal trade, says that wild wholesale speculation has taken place whenever there has been a threatened coal shortage, which showed that Government regulation is needed.

The report, which is supplemental to the Commission's final report issued several weeks ago, accuses the wholesalers of having made excessive profits. Retailers are given credit for having made only moderate profits on the average during the five-year period from 1918 to 1922.

The Commission advocates Federal legislation, including the power to limit to a definite maximum amount per ton the margins that may be taken by one or more wholesalers between the mine and retailer or consumer, thus limiting speculative wholesale sales.

With respect to retail prices the opinion is expressed that the competitive nature of the retail trade makes regulation of margins and prices unnecessary except in cases of emergency shortage. The solution of the problem of extortionate charges for retail coal, it is stated, is largely in the hands of local communities.

The Commission declares that wholesale margins of 8 per cent, the figure advocated by the American Wholesale Coal Association, permit the entire trade, and particularly the wholesalers handling anthracite, to make exorbitant profits. It is shown that a group of wholesalers handling anthracite at margins averaging 8.7 per cent in 1917 obtained returns of 38.4 per cent on total investments and 44.1 per cent on the proprietor's equity.

Chicago wholesalers, according to the report, made a return of 23 per cent on their investment in 1922 as against 8.7 per cent in 1921, 43.3 per cent in 1920, 12.7 per cent in 1921, 43.3 per cent in 1920, 12.7 per cent in 1919 and 16.6 per cent in 1918.

Twenty Chicago retail companies showed a return on their investment in 1922 of 15.5 per cent as against 9.8 per cent in 1921, 25.5 per cent in 1920, 16.9 per cent in 1919, and 19.19 per cent in 1918.

Tant & Wells of Grandfield, Okla., have changed their names to the Tant Feed & Coal Company.

The retail coal business of the Carrie Grain Company at Bradshaw, Neb., has been bought by C. A. Sininger.

Hushka & Hamilton have sold their elevator and coal business at Bradford, Iowa, to the Farmers Elevator Company.

The coal and grain business of the Marion Co-operative Exchange of Marion, Ind., has been bought by Elmer L. Pulley.

W. J. Hager is continuing the retail coal and grain business at Burdette, Iowa, succeeding Hager & Co., which has been dissolved.

E. G. Urban & Co., of McDonald, Kan., is succeeded in the retail coal and grain business by the Morrison Grain Company.

The grain elevator and coal business of Stafford & Lee at Deshler, Ohio, has been bought by George Dull and Charles Harris.

The grain elevator and coal business of Art Murray at Bancroft, Iowa, has been bought by the Bancroft Farmers Elevator Company.

Sherry Brothers of Flanagan, Ill., have dissolved their partnership and Francis Sherry will continue the retail coal and grain business.

The grain and coal business of the Austin Grain Company at Waco, Neb., has been sold to the Shannon Grain Company of Kansas City.

The retail coal and grain elevator business of the Abie Farmers Grain & Lumber Company at Abie, Neb., has been bought by Edward Krenk.

The interest of W. A. Mason in the retail coal, grain and feed business of Ramsey & Mason at Lexington, Ky., has been bought by J. C. Ramsey.

The property of the Farmers Elevator Company at Watertown, S. D., has been taken over by J. E. Sankey, who will operate as the Purity Coal Com-

To deal in coal, grain, etc., the Farmers Grain Company was incorporated at Defiance, Ohio, capitalized at \$6,000. E. W. Costello, R. Roehrig, W. M. Roehrig, V. M. Gruner and S. I. Gruner are interested.

To conduct a retail coal, lime, cement, lumber, flour and feed business, the Davis Coal & Supply Company has been incorporated at Reading, Pa., capitalized at \$50,000. Warren L. Davis, Stuart L. Davis and Paul S. Keller are the incorporators.

The South Side Coal Company at Mishawaka, Ind., has been bought by A. Form from Thomas Fite & Son. He will continue to operate as the South Side Coal, Flour & Feed Company with Samuel Price in charge as manager.

A third plant has been erected in Utah by the J. G. Peppard Seed Company of Kansas City. It is located at Duchesne and represents an investment of about \$15,000. The new plant will be in charge of J. G. Peppard, Jr. It will be equipped with four mills and will have a hopper arrangement designed to distribute the seed to the clippers with least trouble and effort.

W. H. Bauma is now associated with the C. E. DePuy Company of Pontiac, Mich. He was formerly at the head of the feed sales department of the Caughey-Jossman Company of Detroit, Mich. The DePuy Company has just completed a reinforced concrete elevator and feed plant with storage capacity of 75,000 bushels. It is equipped with the latest machinery for handling grain and manufacturing poultry and stock feeds.

Editor American Grain Trade:—Enclosed find my subscription to the AMERICAN GRAIN TRADE the coming year. Tell the boys hay is very short crop. Canadian will cost here about \$27 and looks now as if we will have to have it before the end of the season. FRANK R. MAGUIRE, 33 Thomas Building, Cincinnati, Ohio.

For Sale

ELEVATORS AND MILLS

FOR SALE

Eastern Missouri elevator on Wabash R. R. near St. Louis. Good retail trade; all kinds feeds, coal, wood yard, seeds, etc. A. E. KLINGENBERG, Truesdale, Mo.

WILL SELL HALF OR ENTIRE INTEREST

One of the best grain and lumber points in north central Illinois, located in Stark County, for sale. Has been under one management for practically a quarter of a century. Has two elevators and one lumber yard. P. O. BOX 54, Galesburg, Ill.

MACHINERY

OIL ENGINES FOR SALE

Fifteen-horse Y type; 10-horse Y type. Ready for delivery. A. H. McDONALD, 547 W. Monroe St., Chicago, Ill.

FOR SALE

Pulleys, 1,000; all sizes, solid cast iron, wood and steel split. Elevator belts and buckets and supplies. STANDARD MILL SUPPLY COMPANY, 501 Waldheim Building, Kansas City, Mo.

WILL BE SOLD AT A BARGAIN

One Ellis Grain Drier in good condition and ready for prompt shipment, capacity 350 bushels per. This is a good drier. W. W., Box 11, care AMERICAN ELEVATOR AND GRAIN TRADE, 431 S. Dearborn St., Chicago, Ill.

OIL ENGINES FOR SALE

60-horsepower Fairbanks-Morse.
50-horsepower Otto.
25-horsepower Fairbanks-Morse.
50 other sizes.
A. H. McDONALD, 547 W. Monroe St., Chicago, Ill.

FOR SALE

One 125-h.p. steam boiler.
One 100-h.p. Atlas Automatic Engine.
One rope drive with sheaves, idlers all complete with about 400-ft. good hemp core cable.
One rope drive same as above, 700 ft.
One 72-in. pulley, 10-inch. face, friction clutch attached.
One 66-in. pulley, 10-in. face, friction clutch attached. Both of these clutches are muer steel plate and pulleys are for 3-7/16-in. shaft. All in first-class condition. Any part or all of the above at sacrifice prices. Inquire CRABBS REYNOLDS TAYLOR CO., Crawfordsville, Ind.

FOR SALE VERY CHEAP

Ten thousand bushel steel grain tank; 25-h.p. steam engine and boiler, in very good condition; fine track scale; 1,000-bushel corn sheller, Western make. WABASH GRAIN COMPANY, Oaktown, Ind.

FOR SALE

Attrition Mills: One 18-inch Dreadnaught; four 24-inch Monarch Ball Bearing, some motor driven; 10 plain bearing mills, all sizes.

Feed Rolls: Three three-pair-high 9x24 and 9x18, two two-pair-high 9x24 and 9x18.

Nine Bowsher Mills; corn shellers; motors; dust collectors a specialty; cleaners; separators; 10 large elevators complete—some small ones; elevator cups; hangers; pulleys; shafting; metal spouting. We save you money. A. D. HUGHES COMPANY, Wayland, Mich.

Miscellaneous Notices

FOR SALE

Bank safe, adding machine, two vault doors, counter partitions. THOS. NEW, Rantoul, Ill.

WANTED

To hear from owner having elevator, mill or other property for sale. Give cash price and particulars. JOHN J. BLACK, Chippewa Falls, Wis.

WANTED

Position as manager of farmers' elevator. No place too large. Seventeen years' experience in grain, lumber and coal. Best of reference and bonds. BOX 396, New Hampton, Iowa.

FLOUR AND MILL FEEDS

Mixed cars of flour and mill feeds in 100-pound sacks are our specialties. Would like to send you a trial order to convince you of the superiority of our products. ANSTED & BURK CO., Springfield, Ohio.

CONNECTION DESIRED

Grain man, 42 years old, with college education, desires to make connection with some reliable grain concern. Have had 18 years' experience in all phases of the terminal grain and elevator business with special reference to physical handling and marketing of grains. Can arrange to give services at an early date. B. N. Y., Box 11, care AMERICAN ELEVATOR AND GRAIN TRADE, 431 S. Dearborn St., Chicago, Ill.

Hunt Coupling for Controlling the Stretch of Manila Transmission Ropes



Ask for Descriptive Catalog M-17-1

C. W. Hunt Co., Inc., West New Brighton, N. Y.

Corrugated Sheets

FOR ROOFING AND SIDING

All Gauges, Standard Widths & Lengths
We specialize in furnishing and erecting complete.

Fabricated steel products for grain elevators.

THE SYKES COMPANY

2280 W. 58th Street CHICAGO, ILL.

BOARD
OF
TRADE

CHICAGO

GRAIN
RECEIVERS

EXPORTERS

IMPORTERS

Rosenbaum Grain Corporation
Grain Merchants
CHICAGOPrivate Wires in All Important Markets
Milling Wheat a SpecialtyBranch Offices:
Omaha Minneapolis Oklahoma City Fort Worth Galveston**H. M. PAYNTER**

With ROGERS GRAIN COMPANY

Grain Commission

Correspondence Solicited

Postal Telegraph Building CHICAGO

GEO. S. DOLE, Pres. H. N. SAGER, Sec.

J. H. DOLE & CO.

(Established 1852)

Commission Merchants, Grain and Seeds

We solicit your

CONSIGNMENTS

and orders in futures

327 South La Salle Street - - CHICAGO

**J. C. Shaffer Grain Co.****GRAIN MERCHANTS**

CHICAGO

Consign Your Grain and Seeds to

John E. Brennan & Co.

Commission Merchants

CHICAGO

POPE & ECKHARDT Co.

COMMISSION MERCHANTS

GRAIN AND SEEDS

111 W. Jackson Blvd.

CHICAGO

HITCH & CARDER
CASH GRAIN OUR SPECIALTY

327 So. La Salle Street

Tel. Wabash 6584

CHICAGO

*Future Orders Solicited***YOU** can keep in touch with the news and reports of
the Grain and Elevator world by reading the
"American Grain Trade."**SUBSCRIBE NOW—\$1.00 A YEAR****Clement, Curtis & Co.**

The Rookery Bldg., Chicago

Members of all principal Exchanges.
Private wire service to all leading cities
in this country.**UNIVERSAL GRAIN CODE**

(AND MILL FEED SUPPLEMENT)

Compiled for use of **GRAIN AND MILLING TRADES**

of the United States and Canada

SEND FOR A COPY NOW. PRICE \$3.00.**Mitchell Brothers Publishing Co., 431 South Dearborn St., Chicago, Ill.**



We Buy
Wheat---Corn---Oats---Barley---Rye
Send Samples
The Quaker Oats Co.
Cereal Millers
Grain Dept. 80 East Jackson Boulevard
CHICAGO

"Since 1873"
J. J. BADENOCH CO.
GRAIN
COMMISSION MERCHANTS
320 Postal Telegraph Bldg., Chicago

ARMOUR GRAIN COMPANY
CHICAGO, ILL.
GRAIN DEALERS
Manufacturers of
ARMOUR'S STOCK & DAIRY FEEDS
AND
ARMOUR'S OATS
ARMOUR'S CORN FLAKES
ARMOUR'S PANCAKE FLOUR

Gerstenberg & Company
COMMISSION MERCHANTS
Grain Seeds and Mill Feed
Barley a Specialty
305-315 So. La Salle St. CHICAGO, ILL.

E. W. BAILEY & CO.
COMMISSION MERCHANTS
GRAIN, SEEDS AND PROVISIONS
72 Board of Trade CHICAGO

Lamson Bros. & Co.
Grain
1874 Commission 1923
Merchants
Forty-nine Years of Service in the Grain Trade
166 W. Jackson Boul.
and
8 Board of Trade Chicago

RUMSEY & COMPANY
FOUNDED 1867
COMMISSION MERCHANTS
BOARD OF TRADE
CHICAGO

WEGENER BROS.
GRAIN COMMISSION
CONSIGNMENTS—SALES TO ARRIVE
305 SO. LA SALLE ST. CHICAGO, ILL.

Bartlett Frazier Co.
GRAIN
COMMISSION MERCHANTS
Western Union Building Chicago

In Sunshine and Rain
Consign Your Grain
to the Market You Like
But Remember **UPDIKE**
UPDIKE GRAIN Co.
CHICAGO
Omaha Milwaukee Kansas City
Sioux Falls, S. Dak.

Milling Wheat, Corn and
Oats. Protein test furnished
on wheat where required.
ROSENBAUM BROTHERS
77 Board of Trade Building Chicago, Ill.

A Splendid Value
—At A Splendid Saving
Save money on grain sample envelopes! Our big stock of No. 1 quality All Spruce Kraft Envelopes insures immediate delivery. P. D. Q. Grain Sample Envelopes assure greatest strength linked with sales-building appearance.
Whether you need one or ten thousand, they are offered you at the 10,000 quantity price—a remarkably low price—with only a negligible handling charge added for smaller quantities.
Save money on grain sample envelopes—attach this ad to your order.
GAW-O'HARA ENVELOPE CO.
500 N. Sacramento Boul., Chicago



NASH-WRIGHT GRAIN COMPANY
COMMISSION MERCHANTS
GRAIN AND SEEDS
66A Board of Trade Bldg. Chicago

Wherever hay is handled, there the firm of
BRIDGE & LEONARD
is well and favorably known.
Consignments solicited. Market information furnished.
61-65 Board of Trade Chicago, Ill.



Robinson's Telegraphic Cipher
REVISED AND ENLARGED EDITION
Cloth Binding\$1.75
Leather Binding 2.25
MITCHELL BROTHERS PUBLISHING CO.
431 S. Dearborn St., CHICAGO, ILL.

E. P. BACON CO.
Grain Commission Merchants
Sellers of Cash Grain and
Field Seeds on Consignment
MILWAUKEE—CHICAGO—MINNEAPOLIS

Shippers are assured
Superior Service from
W. M. Bell Company
Milwaukee, Wis.

BOARD
OF
TRADE

KANSAS CITY

GRAIN
RECEIVERS

GET OUR BIDS TO ARRIVE

MOORE-SEEVER
GRAIN CO.
RECEIVERS AND SHIPPERS
520-3 BOARD OF TRADE
KANSAS CITY, MO.

QUALITY
SERVICE

WHEAT
CORN
BARLEY
OATS

CONSIGNMENTS

BOOKS FOR
GRAIN DEALERS

WALLS, BINS AND GRAIN ELEVATORS, by Milo S. Ketchum. Illustrated, 556 pages. Price\$5.00

ROPP'S CALCULATOR, new and improved edition, with complete grain tables, and other invaluable discount and stock tables. Price\$1.00

ROBINSON'S TELEGRAPHIC CIPHER, revised and enlarged. Price.....\$1.75

UNIVERSAL GRAIN CODE, and Feed Mill Supplement. Price\$3.00

Any of the above sent postpaid on receipt of price.

MITCHELL BROS. PUBLISHING CO.
431 S. Dearborn St. Chicago, Ill.

BOARD
OF
TRADE

PEORIA

GRAIN
RECEIVERS

W. W. Dewey & Sons
GRAIN COMMISSION
26 Chamber of Commerce
PEORIA - - ILL.

P. B. & C. C. MILES
Established 1875 Incorporated 1910
PEORIA, ILL.
Handling Grain on Commission
Our Specialty

Louis Mueller, President F. W. Mueller, Sec. & Treas.
MUELLER GRAIN COMPANY
(Incorporated)
Receivers and Shippers **GRAIN**
We Solicit Your Consignments of Grain
Room 39-41 Chamber of Commerce, Peoria, Ill.

Turner-Hudnut Company
GRAIN COMMISSION
42-47 Chamber of Commerce, Peoria, Ill.

LUKE GRAIN COMPANY
38-40 BOARD OF TRADE
PEORIA ILLINOIS

Fumigation Methods
By PROF. WILLIS G. JOHNSON
A complete practical treatise on fumigating grain elevators, flour mills, warehouses, etc. 313 pages. Well illustrated. Price \$2.00.
MITCHELL BROS. PUBLISHING CO.
431 South Dearborn St. Chicago

PRODUCE
EXCHANGE

TOLEDO

GRAIN
RECEIVERS

When "SEEDY"
Try
C. A. King & Co.
GRAIN AND SEED DEALERS
Toledo, Ohio

Like Billy Sunday, we deal in both cash and futures, Toledo and Chicago Born 1846 Read Our Boy Solomon

JOHN WICKENHISER & CO.
Wholesale Grain Dealers
TOLEDO, OHIO
We make track bids and quote delivered prices. Solicit consignments of Grain and Clover Seed.
Members Toledo Produce Exchange and Chicago Board of Trade.

SHAFTING, PULLEYS and BELTING
By Hubert E. Collins
An invaluable work for grain elevators, flour mills, or any other place where machinery is installed. Cloth bound.
Well illustrated. Price \$1.50
Mitchell Bros. Pub. Co. 431 S. Dearborn St., Chicago

Robinson Telegraphic Cipher
Revised Edition
Cloth Binding \$1.75
Leather Binding 2.25
MITCHELL BROTHERS PUBLISHING CO.
431 S. Dearborn Street Chicago, Ill.

The Randolph Grain Company
Receivers and Shippers
GRAIN
Sacked or Bulk
TOLEDO OHIO

FUMIGATION METHODS By PROF. WILLIS G. JOHNSON
A complete practical treatise on fumigating grain elevators, flour mills, warehouses, etc. 313 pages. Well illustrated. Price \$2.00.
Mitchell Bros. Publishing Company, 431 South Dearborn St., Chicago

ASK FOR
SOUTHWORTHS
WHEAT AND RYE BIDS
CONSIGN TO
SOUTHWORTH & CO. TOLEDO

**MERCHANTS
EXCHANGE**

ST. LOUIS

**GRAIN
RECEIVERS**

Ship Your Grain to
McClelland Grain Co.
St. Louis, Mo.
*For Satisfactory Sales
and Prompt Returns.*

Toberman, Mackey & Company
Fastest Growing Commission House in America.
Can handle your consignments in St. Louis and Kansas City.
GRAIN, HAY AND SEEDS
ST. LOUIS KANSAS CITY

**"THE CONSIGNMENT HOUSE
OF ST. LOUIS"**
GRAIN, HAY and GRASS SEEDS
Picker & Beardsley Com. Co.
125 MERCHANTS EXCHANGE

Nanson Commission Co.
(INCORPORATED)
GRAIN AND HAY
202 Chamber of Commerce
ST. LOUIS
Write Us for Full Information on St. Louis Markets
Consignments a Specialty

BUYERS OF TRACK GRAIN OF ALL KINDS AND
MILL FEED
W. J. EDWARDS GRAIN CO.
GRAIN COMMISSION
504 Merchants Exchange St. Louis, Mo.
Carefully Selected Milling Wheat and Corn Our
Specialty

G **MARSHALL HALL GRAIN COMPANY**
HANDLED ON COMMISSION
BOUGHT TO ARRIVE
SOLD FOR SHIPMENT
EXPORT
ST. LOUIS
ST. JOSEPH

GEO. C. MARTIN, JR. President
FRED C. HOOSE Vice-President
P. C. KNOWLTON Sec'y & Treas.
Martin & Knowlton Grain Co.
Successors to
GOFFE & CARKENER CO.
Suite 516 Merchants Exchange, St. Louis, Mo.

**GRAIN
&
HAY
EXCHANGE**

PITTSBURGH

**GRAIN
RECEIVERS**

W. F. HECK & CO.
RECEIVERS—SHIPPERS
Grain, Hay, Straw, Mill Feed
Carloads and Mixed Carloads
705 Wabash Building Pittsburgh, Pa.

HARPER GRAIN CO.
Wabash Building
Modern elevator facilities
at your command.

ESTABLISHED 1872
R. S. McCAGUE, Ltd.
Wholesale
Receivers and Shippers
Corn, Oats, Hay and Mill Feed
417-419 Westinghouse Bldg.
Pittsburgh, Pa.

JESSE C. STEWART CO.
Receivers and Shippers
CORN, OATS, RYE and MILL FEED
AIKEN AVE. AND PENNA. R. R.
PITTSBURGH
Owners of the 130,000-bu. Iron City Elevator

Robinson Telegraphic Cipher
Revised Edition
Cloth Binding \$1.75
Leather Binding 2.25
MITCHELL BROTHERS PUBLISHING CO.
431 S. Dearborn Street Chicago, Ill.

Reference: Farmers Deposit National Bank
SAMUEL WALTON CO.
Receivers and Shippers of
HAY, GRAIN & MILL FEED
Advances on Consignments
CARLOADS ONLY
No. 8 Wood Street PITTSBURGH, PA.

**CHAMBER
OF
COMMERCE**

MINNEAPOLIS

**GRAIN
RECEIVERS**

A Card Ad
in the
"American Grain Trade"
has Excellent Display and
is Always Easy to Find.

Cereal Grading Co.
W. T. FRASER, Vice Pres. & Mgr.
GRAIN MERCHANTS
CHOICE MILLING WHEAT & RYE
Twenty-five years' experience in selecting
and forwarding choice wheat and rye for
mills. Largest rye handlers in the West.
Also shippers of oats, barley and screenings.
Operating Elevator L
612 Chamber of Commerce
MINNEAPOLIS, MINN.

CORN
EXCHANGE

✂ BUFFALO ✂

GRAIN
RECEIVERS

Wheat-Rye-Corn-Barley-Oats
Shipped to
Eastern Grain, Mill and Elevator Corporation
Operators of Concrete Elevator, Central Elevator and Iron Elevator
5,000,000 BUSHELS CAPACITY
Will be properly cared for on arrival and show best possible results

Consignments Only
McConnell Grain Corporation
BUFFALO

ARMOUR GRAIN CO.
BUFFALO, N. Y.

Operating Export Elevator
and the Buffalo Cereal Mill

Consignments solicited

Ship Us Your
Corn, Oats and Wheat
Regardless Of Its Condition
Send us your consignments
PRATT & CO.
OPERATORS OF
SUPERIOR ELEVATOR
910 Chamber of Commerce. Buffalo, N. Y.

S. M. RATCLIFFE
GRAIN
Commission Merchant
Consignments Solicited
Chamber of Commerce, Buffalo, N. Y.

J. G. McKillen, Inc.,
RECEIVERS
Consignments a Specialty
BUFFALO NEW YORK

The Real Market Place
for grain men is centered in
the advertising columns of the
"American Grain Trade"

BOARD
OF
TRADE

✂ DULUTH ✂

GRAIN
RECEIVERS

WHITE GRAIN CO.
SHIPPERS
FANCY OATS
MILL OATS
SCREENINGS
FEED WHEAT
BARLEY
RYE
DULUTH
Write for Samples and Quotations

YOU Can keep in touch with
the news and reports of
the Grain and Elevator
world by reading the "American
Grain Trade."
SUBSCRIBE NOW—\$1.00 A YEAR.

LEADING GRAIN RECEIVERS IN ALL MARKETS

ATCHISON, KAN.

Mangelsdorf Seed Co., seeds.*

BALTIMORE, MD.

Hax & Co., G. A., grain and hay receivers.*†

BUFFALO, N. Y.

Armour Grain Co., export elevator and cereal mill.

Eastern Grain, Mill & Elevator Corporation, wheat, rye, corn, barley, oats.*†

McConnell Grain Corporation, grain.*†

McKillen, Inc., J. G., receiver.*

Pratt & Co., corn, oats, wheat.*

Ratcliffe, S. M., grain and hay.†

Townsend Ward Co., grain commission.*

Whitney-Eckstein Seed Co., wholesale seed merchants.

CAIRO, ILL.

Halliday Elevator Co., grain dealers.*†

Hastings Company, Samuel, shippers oats and corn.*

Hastings-Stout Co., grain and hay.*†

CHICAGO, ILL.

Armour Grain Co., grain buyers.*

Badenoch Co., J. J., grain commission merchants.*

Bailey & Co., E. W., commission merchants.*

Bartlett Frazier Co., receivers and shippers.*

Brennan & Co., John E., commission merchants.*

Bridge & Leonard, hay, grain.*†

Clement, Curtis & Co., commission merchants.*

Dole & Co., J. H., commission merchants.*

Gerstenberg & Co., grain and seeds.*

Harrison, Ward & Co., grain merchants, buyers and shippers.*

Hitch & Carder, grain commission.*

Hoit & Co., Lowell, com. grain, seeds.

Illinois Seed Co., seed merchants.

Lamson Bros. & Co., commission merchants.*

McKenna & Dickey, com. merchants.*

Miller & Co., Albert, hay and produce.†

Nash Wright Grain Co., grain commission.*

Norris Grain Co., grain merchants.*

Paynter, H. M., grain commission.

Pope & Eckhardt Co., grain and seeds.*

Quaker Oats Co., wheat, corn, oats, barley, rye.

Rosenbaum Bros., grain, feeds.*

Rosenbaum Grain Corp., shippers.*

Rumsey & Co., grain commission.*

Shaffer, J. C., & Co., grain merchants.*

Urdike Grain Co., consignments.

Wegener Bros., grain commission.*

CINCINNATI, OHIO.

Perin, Brouse, Skidmore Grain & Milling Co., rec. and shipper.*†

CLEVELAND, OHIO.

Cleveland Grain & Milling Co., receivers and shippers.*†

*Members Grain Dealers' National Association.

CRAWFORDSVILLE, IND.

Crabbs-Reynolds-Taylor Co., grain, seeds.*†

DENVER, COLO.

Ady & Crowe Mercantile Co., grain, hay, beans.*†

DECATUR, ILL.

Baldwin & Co., H. I., grain dealers.*

Harrison, Ward & Co., grain belt elevator.*

DES MOINES, IOWA.

Des Moines Elevator & Grain Co., grain merchants.

Lockwood, Lee, grain brokerage.*

DETROIT, MICH.

Dumont, Roberts & Co., receivers, shippers.*

Huston C. R., grain and hay.*

DULUTH, MINN.

White Grain Co., grain and hay.*†

INDIANAPOLIS, IND.

Bennett & Co., James E., grain, stocks, cotton.

Bingham Grain Co., receivers and shippers.*

Boyd Grain Co., Bert A., grain commission.*

Cleveland Grain Co., grain dealers.*

Hart-Maibucher Co., grain commission.*

Kinney, H. E., Grain Co., grain, hay, feed.*†

Lew Hill Grain Co., commission-brokerage.*

Menzie Grain and Brokerage Co., Carl D., grain merchants.*

KANSAS CITY, MO.

Moore-Seaver Grain Co., corn and oats.*

LIMA, OHIO.

Hurley Buchholtz Co., wholesale grain, hay, straw.†

MEMPHIS, TENN.

U. S. Feed Co., receivers and shippers.†

MILWAUKEE, WIS.

Bacon Co., E. P., grain commission.*

Bell Co., W. M. grain commission.*

Courteen Seed Co., seeds.

Franke Grain Co., grain and feed.

Kamm Co., P. C., grain merchants.*

Milwaukee Grain Commission Co., grain commission.

North American Seed Co., seeds.

MINNEAPOLIS, MINN.

Cereal Grading Co., grain merchants.*

Quinn, Shepherdson Co., grain merchants.*

NEW BERN, N. C.

Meadows, J. A. buyer, hay, grain and feed.*†

NEW YORK, N. Y.

Forbell & Co., L. W., com. merchants.*

Nungesser-Dickinson Seed Co., seeds.

PHILADELPHIA, PA.

Parker Commission Co., grain and general freight brokers.*

Richardson Bros., grain, flour, mill feeds.*

†Members National Hay Association.

PEORIA, ILL.

Dewey & Sons, W. W., grain commission.*

Harrison, Ward & Co., receivers and shippers.

Luke Grain Co., grain commission.*

Miles, P. B. & C. C., grain commission.*†

Mueller Grain Co., receivers and shippers.*

Turner-Hudnut Co., grain commission.*

PITTSBURGH, PA.

Harper Grain Co., grain commission.

Heck & Co., W. F., receivers and shippers.*

McCague, R. S., grain and hay.*†

Stewart Co., Jesse C., corn, oats, rye, mill feed.*

Walton Co., Saml., grain, hay, mill feed.*

SIoux CITY, IOWA

Acme Hay and Mill-Feed Co., mill feeds, tankage.†

ST. JOSEPH, MO.

A. J. Elevator Company, The, consignments solicited.*

ST. LOUIS, MO.

Agricultural Seed Co., seeds.

Edwards & Co., W. J., grain merchants.*

Graham & Martin Grain Co., rec. exclusively.*†

Hall Grain Co., Marshall, grain commission.*

Mangelsdorf & Bro., Ed. F., seeds.

Martin & Knowlton Grain Co., grain, hay, seeds.*†

McClelland Grain Co., grain, hay, mill feeds.*

Nanson Commission Co., receivers, shippers.*†

Picker & Beardsley Com. Co., grain, hay.*†

Prunty, Chas. E., grain and seeds.

Toberman, Mackey & Co., grain, hay, seeds.*†

Turner Grain Co., grain commission.*

SIDNEY, OHIO.

Wells Co., J. E., wholesale grain, seeds.*

TIFFIN, OHIO.

Sneath-Cunningham Co., grain and seeds.

TOLEDO, OHIO.

De Vore & Co., H. W., grain, seeds.*

King & Co., C. A., grain and seeds.*†

Randolph Grain Co., receivers and shippers.

Southworth & Co., grain and seeds.*†

Wickenhiser & Co., John, grain dealers.*

WINCHESTER, IND.

Goodrich Bros., wholesale grain, seeds, hay.*†

**Elevator Machinery and Supplies
Flour and Feed Mill Machinery**

PULLEYS, SHAFTING, GENERAL POWER TRANSMISSION MACHINERY, ROLL GRINDING AND CORRUGATING. LARGEST FACTORY AND STOCK IN THE WEST.

GREAT WESTERN MFG. CO.

General Offices and Works:
LEAVENWORTH, KANSAS

Warehouse and Sales Room:
1400-1402 West 12th Street
KANSAS CITY, MO.

SEE THAT YOUR CONTRACT CALLS FOR

THE CUTLER MEAL DRYER



SOLD BY ALL
MILL
FURNISHERS

Not An
Experiment

All Metal Steam Dryer

IN SUCCESSFUL USE 40 YEARS DRYING

CORN MEAL, HOMINY, BREWERS' GRITS AND MEAL, AND ALL CEREAL PRODUCTS. ALSO SAND, COAL DUST, GRAPHITE, CLAY, ORES, ETC.
Automatic in operation, requiring no attention

THE CUTLER CO., North Wilbraham, Mass.

CATALOG ON REQUEST

**BOOKS FOR
GRAIN DEALERS**

WALLS, BINS AND GRAIN ELEVATORS, by Milo S. Ketchum. Illustrated, 556 pages.

Price\$5.00

ROPP'S CALCULATOR, new and improved edition, with complete grain tables, and other invaluable discount and stock tables. Price.....\$1.00

ROBINSON'S TELEGRAPHIC CIPHER, revised and enlarged.

Price\$1.75

MILLING KINKS, contains 169 illustrated handy devices of great value to the practical elevator operator and miller. Price\$1.25

SHAFTING, PULLEYS AND BELTING, by Herbert E. Collins. An invaluable work for grain elevators, or any other place where machinery is installed; well illustrated. Price\$1.50

FUMIGATION METHODS, by Prof. Willis G. Johnson. A complete practical treatise on the fumigation of elevators, mills, etc; 313 pages; illustrated. Price.....\$2.00

FEEDS AND FEEDINGS, by Prof. W. A. Henry. Illustrated, 613 pages. Price\$4.00

UNIVERSAL GRAIN CODE, and Mill Feed Supplement. Price \$3.00

Any of the above sent postpaid on receipt of price

MITCHELL BROS. PUBLISHING CO.
431 S. Dearborn St. Chicago, Ill.

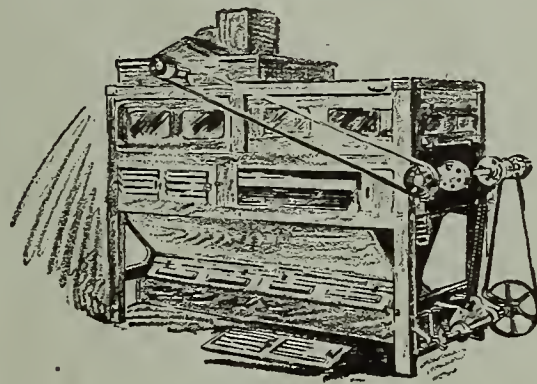

The Wolf Middlings Purifier

ONE strong feature of the improved Wolf Middlings Purifier is the absolute uniformity of air-pull over the entire cloth surface. There are no spots receiving undue air-pull while others are receiving too little. There is no possible chance of any part of the stock passing through the machine unpurified.

The Wolf Middlings Purifier plays an exceedingly important part for good millers who seek to purify the middlings before going to the rolls. Middlings, relieved of the fluffy, fibrous material, go to the rolls clean-cut and make possible the most nearly perfect reduction.

The construction is all that can be desired.

THE SUCTION FAN, located at the tail end of the machine, draws a steady current of air through adjustable panels in head and sides of machine under the sieve. Absolute control of the air current is secured by adjustable valves in the sides of the fan casing.

THE SIEVE FRAMES are suspended from the top rails of the purifier by four adjustable hangers. The silk is tightened by an adjustable cloth stretcher which neither wears nor tears the silk. Balance wheels are located to counterbalance the movement of the sieve.

THE BRUSH CLOTH CLEANER is located directly under the silk and travels automatically from side to side.

GLASS paneled DOORS are placed on each side and across the head and tail ends, permitting the miller to view the flow of stock, the lifting of the impurities, the movement of the cloth cleaners—all without disturbing the air current.

Like all Wolf Machinery, the mechanism of the Purifier is as simple as is the entire process of purification. It consists of a main driving pulley, two balance wheels, pulley for driving the fan, and a pulley for driving the counter shaft which operates the conveyor.

Write today for complete descriptive literature regarding the Wolf Purifier. Ask us to point out to you why the Wolf Purifier is an established success.

NOTE: Write us today to have a Wolf Representative inspect your machinery without obligation. Wolf Representatives are trained milling experts. They will be glad to advise you.

*The Wolf-Dawson
Wheat Washer and Drier*

The Wolf-Dawson Wheat Washer and Drier washes the wheat clean, removes smut and reduces ash content. Its powerful fans aerate and temper to any degree of moisture and toughness. Result: Better Flour—Greater Profits.

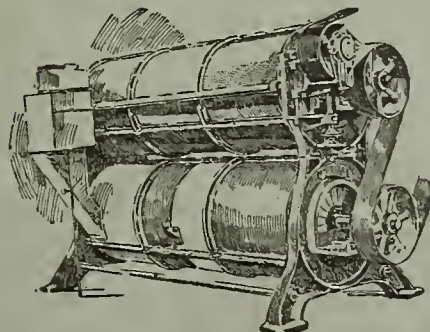

The Wolf Company

Established 1879

Complete Modern Mill Builders and Engineers

4 Flour Exchange Minneapolis, Minn. 400 New York Life Bldg. Kansas City, Mo. 651 Alaska Street Seattle, Wash. 918 North 46th Street Philadelphia, Pa. Chambersburg, Pa. U.S.A.



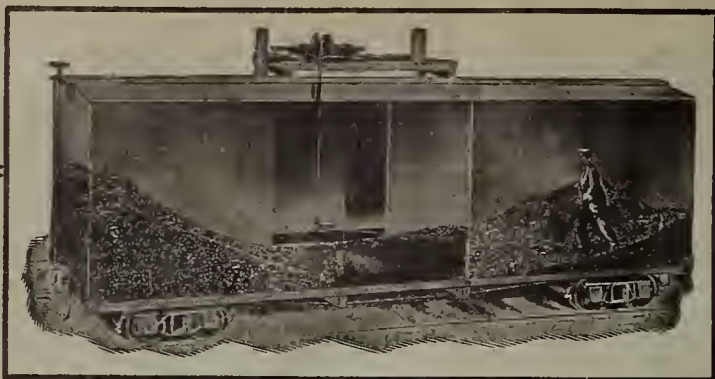

**WELLER IMPROVED
POWER SHOVEL**

Occupies Less Space than Required by Others
Winding Drum is Centrally Located
No Chain Required to Operate the Clutch
Worm Gear Actuates the Stop Lever
Accurate in Operation
Will Handle Grain, Coal, Cement, Sand, Etc.



We Also Make
A Complete Line of High Grade
Grain Handling Equipment
Write for Prices

WELLER MADE SPIRAL CONVEYORS

Evenly
Balanced
Run
True



Sectional
Cold Rolled
Steel
Flights

EASY TO REPLACE WORN FLIGHTS

WELLER MANUFACTURING CO.
1820-1856 N. Kostner Ave. CHICAGO, ILL.

SALES OFFICES:
NEW YORK BOSTON BALTIMORE PITTSBURGH
DETROIT SAN FRANCISCO

**Why Leading Elevators
Use the *MORRIS*
AUTOMATIC GRAIN DRIER**

1. Clean, fresh air is used in both the drier and the cooler.
2. Drying and cooling is regulated by automatically operated gates, adjusted by a timing mechanism for extracting exactly the required degree of moisture.
3. Clogging is impossible. Anything that can get into the drier at the top will come out at the bottom.
4. All dust is eliminated by the Morris Dust Collecting System.

Let us show you how the Morris lowers costs and increases profits. *Write today for facts and the proof.*

MOHAWK

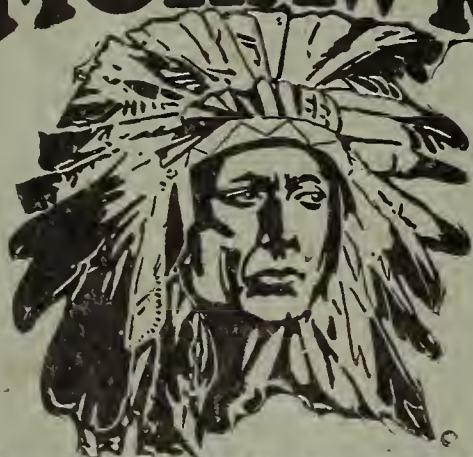

RUBBER BELTING

For many years the Standard Belting for elevators.

Specify this belting when contracting to build or remodel.

Demand it when ordering direct.

The Gutta Percha & Rubber Mfg. Co.

301 W. Randolph St. CHICAGO

New York, Boston, Philadelphia, San Francisco, Seattle

Everything for Every Mill and Elevator

The Strong-Scott Mfg. Co.

Minneapolis Minn. Great Falls Mont.

In Canada: The Strong-Scott Mfg. Co. Ltd. Winnipeg

