

Scanned from the collections of
The Library of Congress

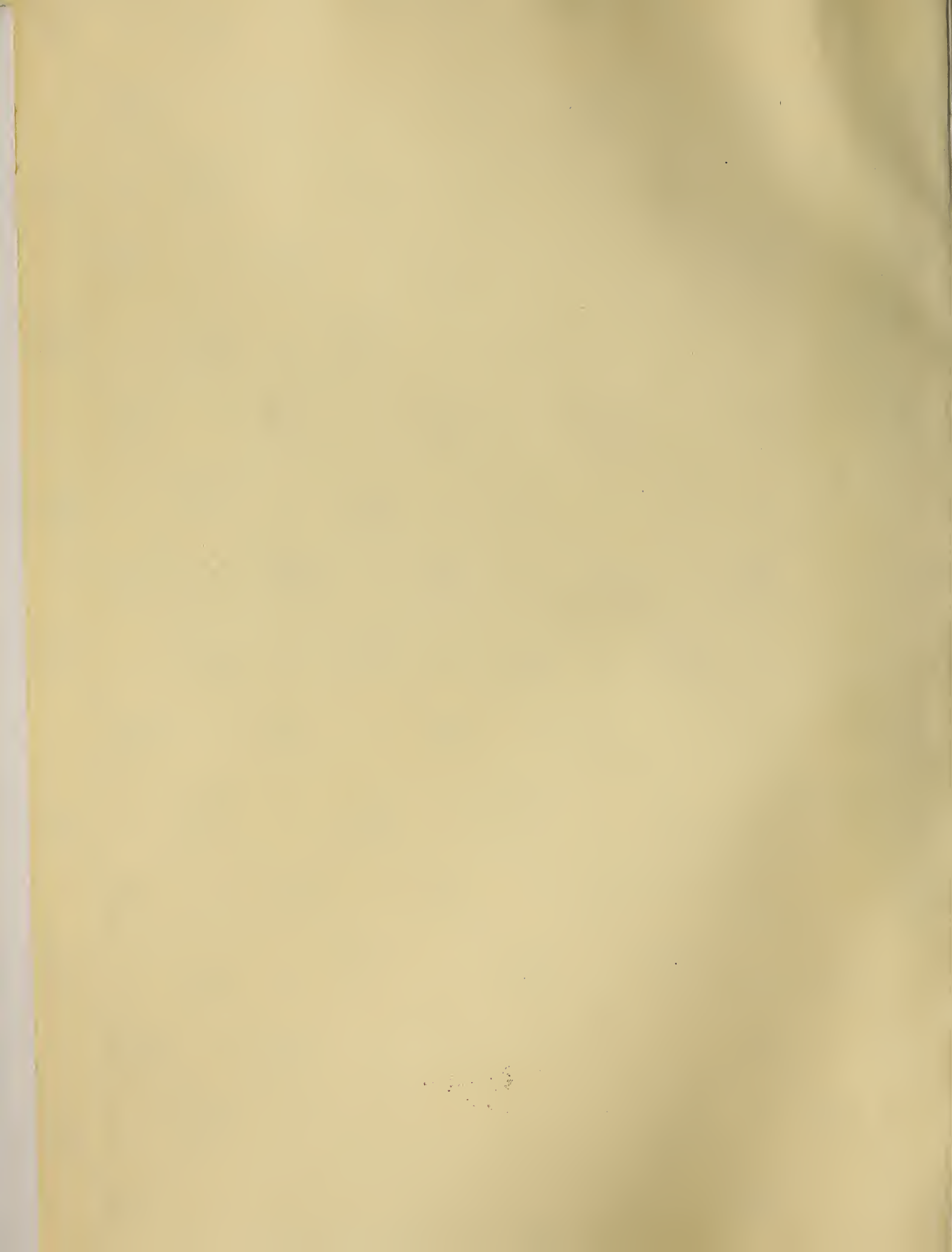

Packard Campus
for Audio Visual Conservation
www.loc.gov/avconservation



B 282606

JAN 25 1951

PROJECTIONIST

**I
N
T
E
R
N
A
T
I
O
N
A
L**



THE LIBRARY OF
CONGRESS
SERIAL RECORD
JAN 25 1951

JANUARY 1951

VOLUME 26 • NUMBER 1

30c A COPY • \$2.50 A YEAR

7 out of 10
choose

Peerless
MAGNARC
TRADE MARK REG

1-KW TO 70 AMPS

"HY-AX" ARC MAGNET

"HY-LUMEN" REFLECTOR

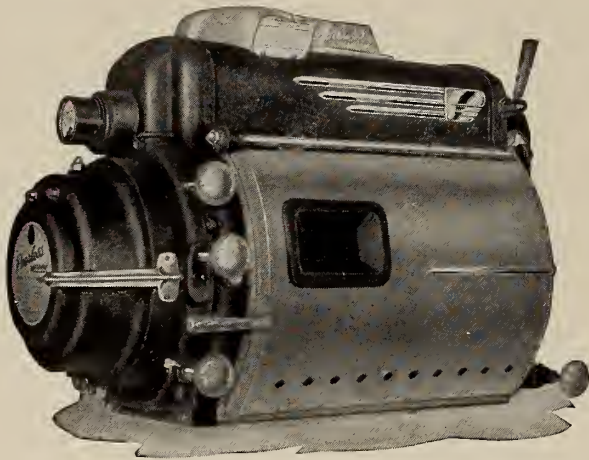

More light at 40 to 70 amperes than ever thought possible. . . . Equals and excels any reflector lamp to 85 amperes, whether they be unapproved water-cooled or resurrected "Hi-Lows". . . . Highest ratio of honest screen lumens per arc watt At 70 amperes, using an accurated Glass Hy-Lumen Reflector*, with a projector having an efficient revolving shutter, it develops the maximum screen brilliance that can be used without a heat filter at no risk of film damage. . . . Operating costs under these conditions are far below that of 85-ampere lamps.

Magnarc Lamps assure 80% side-to-center (SMPE Standard) screen light distribution, not a deceptive 60% or "Hot Center." . . . They are all Und. Lab., Inc. listed. . . . They are not insurance hazards. . . . They are and have been for years "The First Choice" of large and small theatres, drive-ins, and the motion picture industry.

* Similar results are not guaranteed if all-metal reflectors are used.

"FIRST WITH THE FINEST"

120-180 AMPERES

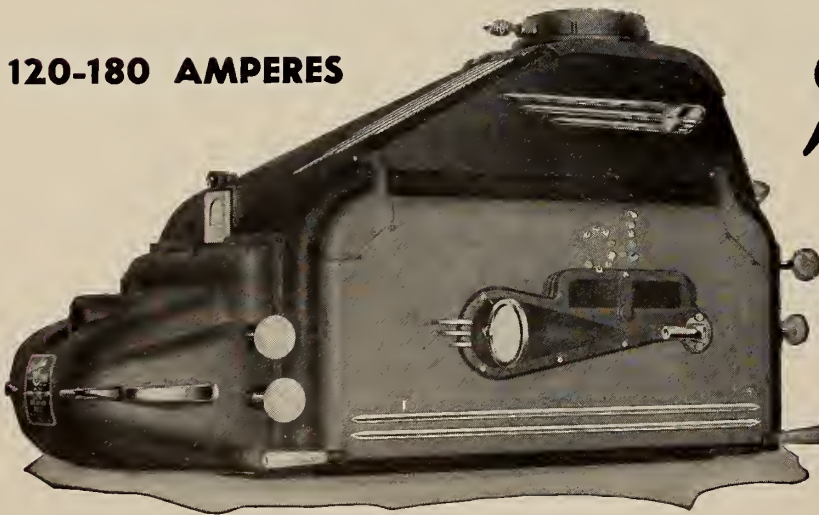

Peerless
HY-
CANDESCENT
TRADE MARK REG

NEW MAGNETIC STABILIZER

This modern lamp produces all the light there is. . . . It is the standard equipment of the nation's largest and finest theatres. . . . Used by 90% of the largest Drive-In Theatres.

It is the "Omega" for maximum screen brilliance. . . . Nothing can even approach it in white light volume when used with projectors that have efficient revolving shutters.

Assures satisfying projection for Drive-Ins regardless of the size of the picture, length of throw, and under all weather conditions. . . . They are Und. Lab., Inc listed and, therefore, not insurance hazards. . . . Heat filter assures no risk of film-heat damage at maximum arc amperage and maximum screen lumens.

"WHY EXPERIMENT?"



J. E. McAULEY MFG. CO.

552-554 WEST ADAMS STREET
CHICAGO 6, ILLINOIS

JAN 22 1951

B 282606

INTERNATIONAL

PROJECTIONIST

With Which Is Combined PROJECTION ENGINEERING



HENRY B. SELLWOOD, Editor

Volume 26

JANUARY, 1951

Number 1

Index and Monthly Chat	3	In the Spotlight	16
Maintenance and Servicing of Motors, III	5	HARRY SHERMAN	
ROBERT A. MITCHELL		Brush-Up on Fundamentals, II: Capacitance	18
Lacquer Coating for Cine Film.	6	The Ashcraft Hydro-Arc Lamp.	19
Old, New Equipment Display a Good Exploitation Stunt	9	New Technicolor Lighting Sys- tem Tested by Top Photog- raphers	20
Theater Television via the RCA PT-100 Equipment, II	10	LEIGH ALLEN	
RCA SERVICE COMPANY		Projectionist Examination Ques- tions	20
Standard 16-m Travel-Ghost Test Film	12	National Carbon Reduces Cop- per Coating; Amperage Cut.	21
AMERICAN STANDARDS ASSOC.		Telecasts	22
Carbon Arcs vs. Inkie for Non- Theatrical Projection	13	IA Elections	23
HARRY H. STRONG		News Projections	25
This 'Mysterious' Aerial Image.	15	Technical Hints	
ROBERT A. MITCHELL		Miscellaneous Items	

Published Monthly by

INTERNATIONAL PROJECTIONIST PUBLISHING CO., INC.

19 West 44 Street, New York 18, N. Y.

Telephone: MUrray Hill 2-2948

R. A. ENTRACHT, Publisher

SUBSCRIPTION REPRESENTATIVES

AUSTRALIA: McGills, 183 Elizabeth St., Melbourne

NEW ZEALAND: Te Aro Book Depot, Ltd., 64 Courtenay Place, Wellington

ENGLAND and DOMINIONS: Wm. Dawson & Sons, Ltd., Macklin St., London, W. C. 2

YEARLY SUBSCRIPTION: United States and possessions, \$2.50 (two years, \$4); Canada and foreign countries, \$3; single copies, 30 cents. Changes of address should be submitted two weeks in advance of publication date to insure receipt of current issue. Entered as second class matter February 8, 1932, at the Post Office at New York, N. Y., under the act of March 3, 1879. Entire contents copyrighted, 1951 by International Projectionist Publishing Co., Inc. INTERNATIONAL PROJECTIONIST is not responsible for personal opinions appearing in signed articles in its columns.



MONTHLY CHAT

328
44

IT'S ironic that when film exhibitors finally got around to effecting some degree of cohesion and displaying a bit of spunk with respect to a go-ahead on theater Tv, the defense needs of the country became so acute as to render their efforts futile. The same degree of courage and savvy, if evidenced two or more years ago, might have created a situation wherein the exhibition field today would be in a strong spot to battle the inroads of network Tv upon the box-office take.

It is all very well to announce that theater Tv will be installed in 71 houses of a given circuit—as both RCA and Fox West Coast Theaters did in recent weeks—but it is quite something else to gain this goal when one stops to ponder the amount of critical defense items that necessarily would be included in this number of units.

It is not our intent to disparage the forward-looking stand of both RCA and the exhibition group, but it seems a pity that such aggressive action could not have been taken many months ago at a time when the FCC was disposed to look with favor on the expansion of a theater Tv chain. The present time, which sees even run-of-the-mill items severely restricted in favor of defense needs, seems hardly the time to announce the creation of a theater Tv setup involving upwards of a hundred units—just as a start.

It is barely possible that the international situation will suddenly take a turn for the better; but even if this near-miracle should eventuate, it is sheer nonsense to suppose that Uncle Sam would cut drastically his rearmament program. It seems certain that we face at least three years of equipment scarcities, with the motion picture theater slated to enjoy no particular favors from Uncle Sam.

The situation is rather a tough one for projectionists to accept with equanimity, because the craft has gone along month after weary month in the hope that exhibitors would bestir themselves and really take positive action anent theater Tv. Alas, it was not to be.

For the present, therefore, projectionists must mark time and nourish the hope that somehow the theater field will be permitted enough leeway to erect a bulwark against those forces now threatening the box-office. That the craft will do more than its full share in the materials conservation program goes without saying. For the rest, it can only grimly get on with its work and hope for the best.

And we hope that this time the contributions of the organized crafts will not be overlooked when the kudos are handed out to the industry.

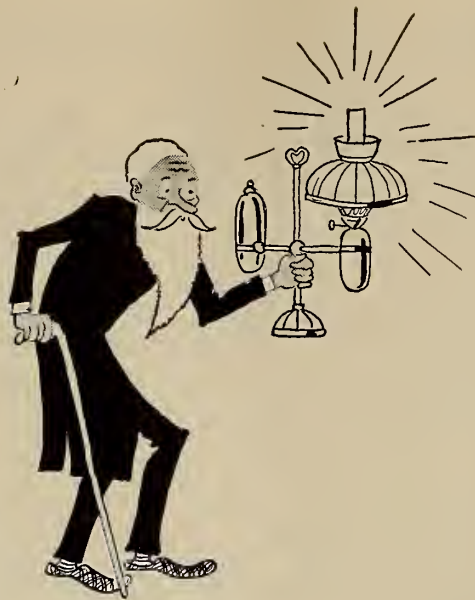

Are your lamps old enough to vote?

Switch now to **NATIONAL** TRADE-MARK **High Intensity Projector Carbons!**

VALUES IN "NATIONAL" PROJECTOR CARBONS

- Brightest, whitest light available in this size carbon
- Steadier burning, greater dependability
- Perfect color balance
- Complete technical service by National Carbon specialists
- Always readily available through your local dealer
- Economical to operate

If you are now using old-fashioned projection lamps of any type, get rid of them. Switch to the finest and most modern projection in the world, with "National" High Intensity projector carbons.

"National" "Suprex" carbons provide the brightest light for their size and current input that you can obtain. This light is perfect in color balance. It throws a vivid, detailed and thoroughly satisfactory picture on the screen.

When you buy projector carbons—
BUY "NATIONAL"

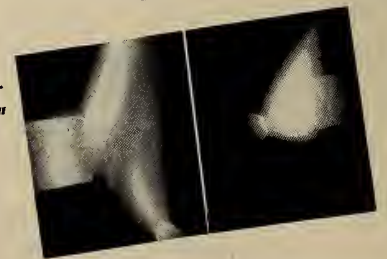

SLASH BATTERY COSTS IN HALF

With the revolutionary new "Eveready" No. 1050 Flashlight Battery you get these big exclusive features:

- More than twice as much light
- Whitest, brightest light available from a flashlight battery
- Half the cost for light output
- Leakproof—no metal can to leak or corrode
- Will not swell, stick or jam in a flashlight

Why? Because of the exclusive "inside-out" construction of the "Eveready" No. 1050 battery. Instead of being the container for the cell, the zinc electrode is on the inside to make the battery

last longer, while the new outside carbon jacket makes the battery leakproof. Order a supply of No. 1050's today.

The terms "National", "Suprex" and "Eveready" are registered trade-marks of

NATIONAL CARBON DIVISION
UNION CARBIDE AND CARBON CORPORATION
30 East 42nd Street, New York 17, N. Y.

District Sales Offices: Atlanta, Chicago, Dallas, Kansas City, New York, Pittsburgh, San Francisco
In Canada: National Carbon, Ltd., Toronto 4



Maintenance and Servicing of Motors

BEFORE attempting to diagnose motor troubles the projectionist should make certain of the type and specifications of the motor. This information is usually given on the nameplate of the motor.

- (1) Manufacturer's name.
- (2) Serial number. This number is necessary when ordering parts.
- (3) Type of motor, which may be D.C. (shunt, series, or compound); "universal A.C.-D.C."; synchronous, or induction. Induction motors of the single-phase type are usually described as "split-phase," "capacitor," or "repulsion-induction" motors, depending upon the principle utilized for starting.
- (4) Phase. Most motors designed for operation on A.C. are single-phase and 3-phase.
- (5) Cycles: 25, 50, or 60 cycles.
- (6) Volts: line voltage should be within 10% of the rated voltage.
- (7) Horsepower. Motors rated at $\frac{1}{8}$, $\frac{1}{6}$, $\frac{1}{5}$, $\frac{1}{4}$, $\frac{1}{3}$, $\frac{1}{2}$, and $\frac{3}{4}$ H.P. are known as "fractional horsepower motors."
- (8) R.P.M. refers to the speed in revolutions per minute.

Explanation of Indicia

In addition to these data, certain other information is sometimes given on the nameplate. The model and the order numbers of the motor, for example. Temperature-rise rating is a guarantee that the motor will not get hotter than room temperature *plus* the stated temperature rise, if correctly operated and not overloaded. The rise rating for most "open" motors is 40° C. (104° F.), or 50° C. (122° F.) Such a motor may feel decidedly warm to the hand, but not uncomfortably hot. Many "en-

By ROBERT A. MITCHELL III. Trouble-Shooting Charts

closed" motors have a rating of 55° (131° F.) rise.

The term "open" on a nameplate means that the end brackets have openings and that the rotor shaft has vanes affixed to draw cool air over the windings and expel the heat generated. Such a motor should not be housed in an airtight compartment, as this would lead to overheating of the motor.

Obtain, if possible, the manufacturer's instructions for lubricating and servicing each type of motor used in the projection room, generator room, and back-stage.

The bearings are more subject to wear than any other part of a motor, and hence should be periodically inspected according to the schedule previously given. The condition of sleeve bearings is in a large measure indicated by the air gap between stator and rotor pole-pieces. Worn bearings will lower the rotor, and may even allow the rotor to strike against the stator. Ball bearings should be checked for heating and noisy operation.

Commutators and brushes are involved in the servicing of D.C., universal, and repulsion-induction motors.

Grooved and lop-sided commutators must be "trued" in a lathe, but minor irregularities may be removed by using a small commutator stone or 00 sandpaper wrapped on the end of a stick and applied to the commutator while the motor is running. (Never use emery paper on commutators!) The mica insulation between the commutator bars should be

undercut about 1/16 inch, as copper wears faster than mica. A steel slotting tool is used for undercutting, and a V tool for giving the edges of the copper bars a very slight bevel. After the mica slots have been cleaned, the mica surfaces should be coated with glossy red enamel of the iron oxide or synthetic type.

A commutator is "dressed" by cleaning with a dry rag, applying a small amount of vaseline to the copper bars with a clean rag, and then wiping off the vaseline. When in good condition, a commutator will have a chocolate-brown color due to an extremely thin film of copper oxide. The carbon of the brushes and the oxygen of the air help maintain this desirable brown coating.

All brush rigging must be kept clean and in good working order. The tension of the brushes (about 1½ pounds per square inch of brush surface) must be checked occasionally. Too much tension may cause chattering and rapid grooving of the commutator. The pigtail connections must be tight.

Care in Brush Selection

The importance of using the right type and grade of brush for each motor cannot be overemphasized. The brush material, whether graphite, electrographite, metal graphite, carbon graphite, or hard carbon, must have a definite resistance in ohms per cubic inch, a certain current-carrying capacity in amperes per square inch of brush face, and a specified contact area. New brushes may be shaped to fit the curvature of the commutator by placing a strip of sandpaper on the commutator and working back and forth while the brush is pressed down upon it.

Further servicing information is sup-

plied by the accompanying trouble-shooting listings. These summaries give data for D.C. and "universal" motors, for polyphase induction motors (the type of motor most often used in 3-phase motor-generator sets), and for all single-phase induction motors. Most A.C. projector motors fall into the last-named class.

1. BEARINGS TOO HOT

Trouble: Bearing dry. **Cause:** Insufficient lubrication, or the wrong lubricant. **Remedy:** Clean bearings and refill with fresh oil or grease of the type recommended by the manufacturer of the motor. On small motors, examine and clean felt wipers.

Trouble: Bearing dirty. **Cause:** Dust or dirt in oil or grease. **Remedy:** Clean out oil or grease reservoir and refill.

Trouble: Tight bearing. **Cause:** Insufficient lubrication, or undersized bearing, if bearing has been replaced. **Remedy:** Provide lubrication. Polish shaft with fine emery paper, or replace bearing.

Trouble: Bearing binding. **Cause:** Shaft "sprung," or too much strain on pulley. **Remedy:** "True" the shaft in a lathe and renew bearing in any case.

Trouble: Loose bearing. **Cause:** Vibration and wear. **Remedy:** Tighten screws holding bearing. Replace worn bearing.

2. ENTIRE FRAME TOO HOT

Trouble: Transference of heat from bearings or armature. **Causes and Remedies:** See Causes and Remedies under 1 and 3.

Trouble: Transference of heat from field coils. **Cause:** Overload, too much current, or shorted coils. **Remedy:** Decrease load or increase size of motor. Operate motor on correct voltage. Replace defective field windings with new ones.

When operating on D.C., a short-circuited field coil is cooler than those adjacent to it. On A.C., the short-circuited coil is hotter than those adjacent to it, and may even smoke. If difficulty is experienced in locating the short-circuited coil, impress full voltage across the windings and test the magnetic pull of each coil with a screwdriver. The coil in which the magnetic pull is least is the shorted one.

3. ARMATURE TOO HOT

Trouble: Overload. **Cause:** Driven machine binding, or motor too small. **Remedy:** Correct mechanical defects or use larger motor.

Trouble: Armature out of center between poles. **Cause:** Worn bearings. **Remedy:** Replace bearings.

Trouble: Moisture in coils. **Cause:** Operating in a damp place. **Remedy:** Dry out by baking in warm oven or running with no load. Improve operating conditions.

4. SPARKING OF BRUSHES

Trouble: Brushes not properly set with regard to the field winding. **Cause:** Misadjustment of brushes, or end-bell shifted to wrong position. **Remedy:** Shift the brush-holders or end-bells.

The brush position on universal motors of small size is fixed by the manufacturer, and cannot be changed. On the types where the end-bells can be shifted, there are holes through

which the bolts holding the end-bells pass. This trouble is not likely to be encountered except when the motor has been taken apart and carelessly assembled.

Trouble: Brushes cover too many commutator bars. **Cause:** Brushes too thick. **Remedy:** Use brushes of proper thickness. Replace brush-holders if they show signs of wear.

Trouble: Brushes too short. **Cause:** Wear. **Remedy:** Replace with new brushes.

Trouble: Poor contact between brush and commutator. **Cause:** Oil or dirt on commutator. Grit in brush. **Remedy:** Clean commutator with dry rag, then "dress" it with a mere trace of vaseline. Use brushes of better quality.

Trouble: Rough or uneven commutator. **Cause:** Vibration, different quality of bars, and uneven ridges where brushes do not wear the commutator. **Remedy:** If the trouble is slight, the roughness may be removed with a commutator stone or 00 sandpaper (NOT emery paper). Otherwise the commutator should be trued in a lathe.

Trouble: High, low, or loose bars. **Cause:** Clamping cone loose. Commutator mishandled. **Remedy:** Press the high bars back into place, raise the low bars, carefully tighten locknut or set-screws, and finally true the commutator in a lathe.

Trouble: High mica. **Cause:** Commutator wear. (Copper wears faster than mica.) **Remedy:** With a sharp steel tool undercut the mica below the level of the

copper bars. Wipe free of dust and dress the commutator.

Trouble: Weak magnetic field. **Cause:** Short circuit in field windings. **Remedy:** Replace defective coils. (See fine-print note under Symptom 2.)

Trouble: Excessive current in armature. **Cause:** Load too great for size of motor. **Remedy:** Reduce load or obtain larger motor.

Trouble: Grounds in armature or commutator. **Cause:** Defective insulation. **Remedy:** Remove ground if possible or, if not, cut out the grounded coil and bridge grounded commutator bar. (The grounded coil should be rewound, or the armature replaced, at the earliest opportunity.)

Trouble: Short circuit in armature. **Cause:** Defective insulation. **Remedy:** As a temporary expedient, cut out short-circuited coil and bridge across the commutator bar involved.

Trouble: Commutator bars short circuited; mica worn or chipped away, causing deep pits between bars. **Cause:** Copper or carbon dust between commutator bars, or melted solder from leads between the bars. **Remedy:** Remove foreign matter from between bars and paint the exposed mica insulation with glossy red enamel of the iron oxide or synthetic type.

5. BRUSHES SING

Trouble: Brush pressure too great. **Cause:** Brush-holder springs not properly

Lacquer Coating for Cine Film

Equipment used to preserve valuable film subjects and effect tremendous savings in print costs (IP for Dec., 1950, p. 14).



Corner of Escar's motion picture laboratory, showing lacquer coating machine for 16- and 35-mm films. Controlled heat and filtered air quickly dry coated film.

Glass-enclosed dustproof lacquer applicator is shown at left. As film leaves supply reel, it travels over rotary applicator which deposits thin coat of lacquer on film surfaces.

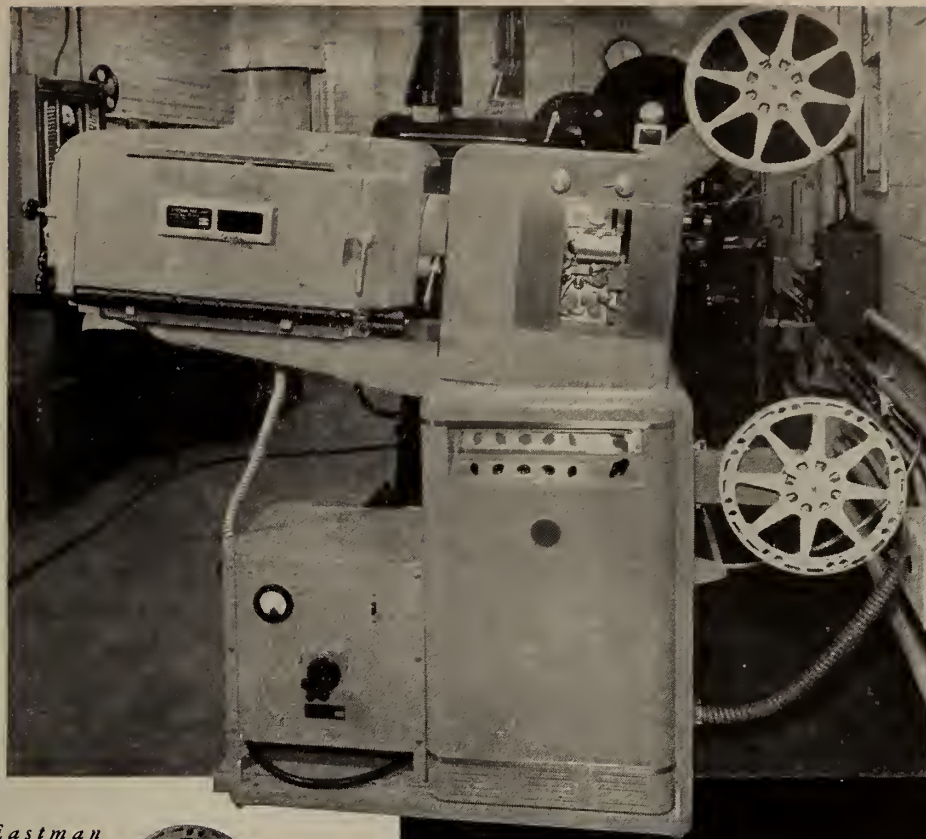

Left, the Eastman 16mm. Projector, Model 25, brings 16mm. projection to the professional level. Shown here, adapted for arc illumination, permanently installed alongside 35mm. equipment.

Below, working parts of the film movement mechanism are in constant view of the operator... readily accessible for threading and cleaning.

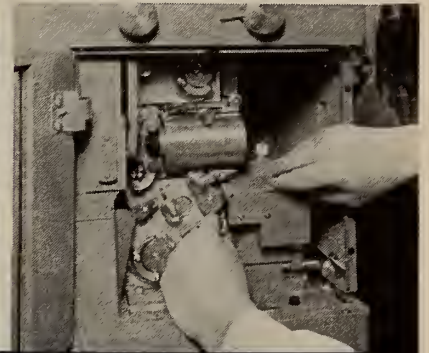

The Eastman 16mm. Projector, Model 25, adapted for 1,000-watt tungsten light.

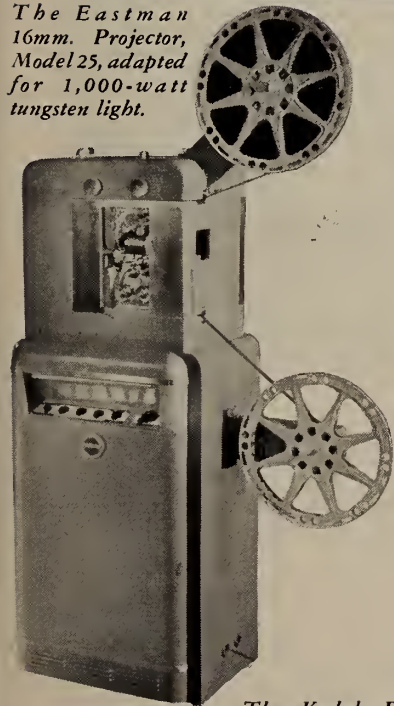

The Kodak Projection Ektar Lens, in a choice of four focal lengths, insures superior screen image.



East Coast Division
342 Modison Avenue
New York 17, N. Y.

*Engineered to the Most Exacting
Professional Standards*

The Eastman 16mm. Projector, Model 25

Exhibitors of 16mm. motion pictures have long needed a professional quality sound motion picture projector designed for permanent installation and capable of continuous, trouble-free performance.

The Eastman 16mm. Projector, Model 25, fills this need. It is designed for permanent installation. It delivers flawlessly brilliant screen images of top theatrical calibre. It gives assured trouble-free performance on a continuous year-round exhibitor's schedule.

The Eastman 16mm. Projector, Model 25, can be installed fitted for tungsten illumination or arc-lamp illumination.

There is a wide choice of accessories which allows you to assemble a complete, permanent installation tailored for your present and future needs. Superb projection optics, completely Lumenized, are furnished by the 2-inch, $f/1.5$ Kodak Projection Ektar Lens, as standard equipment.

When you want professional, trouble-free, continuous-duty, 16mm. sound projection, specify the Eastman 16mm. Projector, Model 25. For information and prices, write directly to the Motion Picture Film Department, Eastman Kodak Company, 343 State Street, Rochester 4, N. Y., or any branch office.

Motion Picture Film Department, Eastman Kodak Company, Rochester 4, N. Y.



Midwest Division
137 North Wabash Avenue
Chicago 2, Illinois

West Coast Division
6706 Santa Monica Blvd.
Hollywood 38, California



EVEN IN FAR OFF TURKEY

they demand

STRONG PROJECTION LAMPS

The Lâle Theatre of Istanbul; the Olimpia of Trujillo City, Dominican Republic; the Austurbaejar Bio of Reykjavik, Iceland; theatres in Egypt, Malaya, Uruguay, India, South Africa, France, Switzerland, Algeria, Finland, Spain, Australia, Chile, Norway, Holland, Sweden, Colombia, Brazil, Venezuela, Portugal, Italy . . . in fact, theatres in practically every country use them. Yes, when it comes to projection lamps, Strong is the name that is respected the world over.

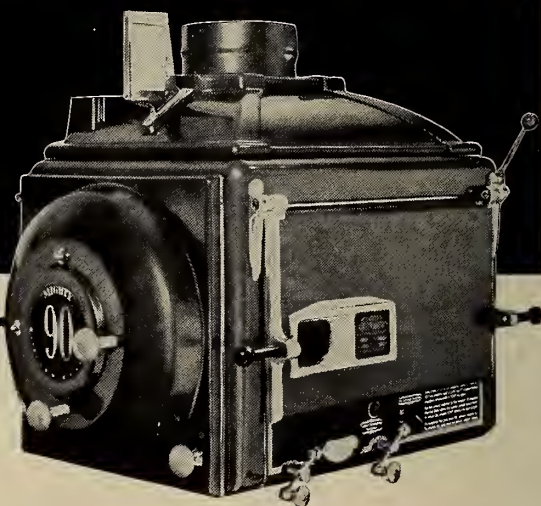

*Put More Light
On Your Screen*

AT FAR LESS COST WITH THE

STRONG MIGHTY "90"

Peer of all lamps, it delivers positively the most light that can be projected to any screen, REGARDLESS OF SIZE! This 75 to 130 ampere reflector arc lamp, at 90 amperes projects 21,000 lumens with far greater operating economy. « Exclusive Lightronic Automatic Focus Control. « Forced air cooled feed mechanism. « Bi-Metal Lightronic tube controls both carbon feed motors. « Big 16½" reflector. « Air stream arc stabilization. « Rugged burner mechanism. « Complete combustion of black soot. « White deposit on reflector prevented. « Unit construction permits instant removal of major components.

USE COUPON NOW!

THE STRONG ELECTRIC CORPORATION
31 CITY PARK AVENUE • TOLEDO 2, OHIO

I would like a demonstration of the Strong Mighty "90" in my theatre, without cost or obligation.

Please send free literature on the Mighty "90"; Mogul Lamp; Utility Lamp; Strong Arc Spotlamps; Strong Rectifiers; Strong Reflectors.

NAME _____
THEATRE _____
STREET _____
CITY & STATE _____

adjusted. *Remedy:* Remove part of the brush tension.

Trouble: Brushes of the wrong type used. *Cause:* Brushes probably too hard. *Remedy:* Use brushes recommended by the manufacturer of the motor. In lieu of this information, try graphite brushes to eliminate singing.

Trouble: Dirty commutator. *Cause:* Improper dressing of commutator, dust and dirt from air, over-oiling of motor. *Remedy:* Clean commutator with dry rag, then rub a small quantity of vaseline on the commutator with a clean rag, and finally wipe off the commutator. (A properly dressed commutator will have a thin chocolate-brown film of copper oxide.)

6. BRUSHES CHATTER

Trouble: High bars. *Cause:* The cone or V-ring holding bars in place loose. *Remedy:* Carefully drive high bars back into place and tighten cone at end of commutator. Smooth commutator with stone or 00 sandpaper, or true in a lathe.

Trouble: Low bars. *Cause:* Wearing away due to soft bars or short-circuited coils. *Remedy:* Loosen cone and lift low bars. If mica insulation of cone is cut through, replace to avoid short-circuiting of commutator. True commutator in a lathe.

Trouble: High mica. *Cause:* Commutator worn. (Copper wears faster than mica.) *Remedy:* By means of a sharp steel tool, cut mica about 1/16 inch below level of bars. Clean the commutator, paint the mica insulation with glossy red enamel of the iron oxide or synthetic type, and finally, when the enamel is dry, dress the commutator with a trace of vaseline.

Trouble: Loose bars. *Cause:* Cone or V-ring loose. *Remedy:* Even up the bars and tighten the cone. As a safeguard, test commutator for grounds with any circuit-testing device. True the commutator in a lathe.

7. ARMATURE MAKES CLICKING OR POUNDING SOUNDS

Trouble: Armature striking or rubbing pole pieces. *Cause:* Worn bearings. *Remedy:* Replace bearings.

8. MOTOR FAILS TO START

Trouble: Load too great. *Cause:* Motor too small for load, bearings too tight, or driven machinery binding. *Remedy:* Use motor of proper capacity. Polish shaft with emery cloth. Inspect driven machinery, and disconnect load to see if motor runs light.

Trouble: Open circuit in line. *Cause:* Fuse blown. Wires broken or disconnected. *Remedy:* Replace fuse. Examine line and connections, and restore circuit. Open up motor leads, and test both line and motor leads.

Trouble: Open circuit in field or field connections. *Cause:* Disconnected or broken wires; burned-out coil. *Remedy:* Test field connections with circuit tester.

Trouble: Open circuit in armature. *Cause:* Broken wire, burned coil. *Remedy:* Test adjacent commutator bars with circuit tester. Bridge over open coil as tem-

porary expedient, later replacing armature.

Trouble: Short circuit in field. *Cause:* Defective insulation or, rarely, dampness. *Remedy:* If the insulation is defective, the field will have to be rewound. This is especially the case when the motor has been exposed to a film fire. Bake the field windings if damp.

Trouble: Brushes not in contact with commutator. *Cause:* Brushes fit too tightly in holders. *Remedy:* Clean the holders, and adjust brushes so that they work easily.

Trouble: Faulty commutation. *Cause:* Brushes not set on neutral point. *Remedy:* On some motors, move end-bells; on a few types, move stator core inside frame. (This trouble will not occur unless the motor has been taken apart and wrongly assembled.)

9. MOTOR RUNS BACKWARD

Trouble: Reversed connection. *Cause:* Field or armature connections wrongly made; end-bell shifted 90 degrees in com-

pensated motors. *Remedy:* If operated on D.C., reverse either the field or the armature connections. Do the same with straight series universal motors operated on A.C. In motors having compensating windings, shift the end-bell 90 degrees.

[To be Continued]

French Film Theater Equipment

As of July 1 last, there were 5145 theaters with 35-mm equipment operating in France, with a total seating capacity of 2,475,177. There were also about 1250 theaters or halls operating with 16-mm equipment.

With the renewed availability of materials, as well as the aid granted by the Government toward the refurbishing of theaters, pre-war French, U. S. and other foreign equipment is gradually being replaced, almost entirely by new French equipment. In general, however, equipment is badly worn, much of it is still pre-war. Exchange restrictions render the opportunity for U. S. equipment practically non-existent.

Old, New Equipment Display a Good Exploitation Stunt

DISPLAYS of new and old projection equipment in dealers' store windows are not uncommon, and even theater lobbies have exhibited replicas of new equipment that has been installed. Seldom, however, is there a display of the new and the old in theater lobbies as an exploitation move designed to direct attention to the great technological strides forward that have been made within the past three decades, or prior to the introduction of sound pictures.

Just such an unusual display was staged recently at the Astoria Theater, Chippenham in Wiltshire, in the west of England. For the recent opening of his provincial-town theater, D. Shield, manager, arranged a display of various types of projection equipment, ancient and

modern. The accompanying illustration shows a corner of this display in which is set up an "ancient" 1920 model projector—the openwork, dirt-collecting type—and the latest Westrex sound system and associated equipment.

The photo is reproduced here through the cooperation of H. B. Allinsmith, managing director of Westrex Corp. of England.

This stunt should commend itself to supply dealers and exhibitors everywhere as a most interesting exhibit for the average theatergoer, particularly those men who are mechanically minded and who seldom, if ever, have had an opportunity to inspect a modern sound projection outfit. It follows, of course, that any such effort should have the unstinted cooperation of the projectionist craft.

Set-up for old and new projection equipment an effective lobby display.

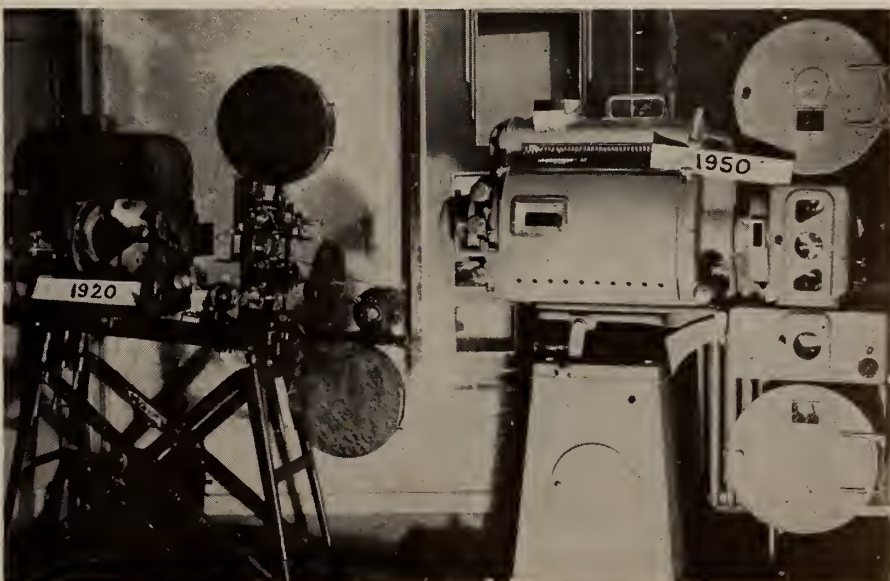

Theater Television

via the RCA PT-100 Equipment

By TECHNICAL PRODUCTS DIVISION, RCA SERVICE CO., INC.

II. Tracing the Signal Through the Equipment

IN LOCATIONS where a standard broadcast television signal of good quality and ample strength is available, and noise interference is negligible, it will occasionally be desirable to use such broadcast signal as program source. To enable this to be readily accomplished, a specially constructed receiver is built into the RCA PT-100 Tv projector. This receiver is capable of reception on any of the 12 standard Tv broadcast channels.

When maximum performance for air pickup is required, a separate, highly directional antenna may be installed for each channel desired, and a plug-and-jack switchboard installed near the Tv

projector control rack to allow selection of antenna for connection to the receiver.

Program Selection Switching

The PT-100 theatre Tv projector is provided with twin interlocking pushbutton switches to permit the projectionist to select his program material from either of two incoming lines, or to instantaneously change from one line to the other. The pushbuttons are interlocked so that pushing either will release the other, if it has been previously depressed. This prevents mixing the two incoming programs, which would occur if both buttons were depressed simultaneously.

One pair of these switches is for sound signal input and one pair for video signal (picture) input. The equipment is shipped from the factory with the sound and picture signal outputs of the Tv receiver connected respectively to line No. 1 audio switch and line No. 1 video switch. When these two buttons are pushed, these outputs of the Tv receiver are connected to the projector.

Video signal from a coaxial line or an UHF radio relay link can be connected to video line No. 2, and its corresponding sound to audio line No. 2. When these two buttons are pushed, coaxial line signal will be fed into the projector.

When either one of the two "projector audio" buttons is pushed, sound signals from the corresponding input line are fed to the audio volume control, which is located on the projector control panel. From the output of the audio volume control, the sound signals pass into a special input switch connected to the regular theatre sound system. Here they are amplified and sent to the regular stage speakers just as in the reproduction of sound from film.

The audio volume control on the projector control panel is provided to allow the operator to properly adjust the sound volume in the auditorium without leaving the Tv projector control rack.

An "audio monitor jack" is located on the signal selector panel. This permits headset monitoring of the incoming audio

signal on either line, merely by pressing the corresponding audio monitor button, regardless of whether one of the audio projector buttons is depressed. The two monitor buttons also are interlocked so that pressing one releases the other.

Path of Video Signal

The video signal coming from the receiver (line No. 1) or from the coaxial cable or UHF beam line (line No. 2), whichever is selected by the projector video pushbuttons, then goes through a pre-amplifier and to the video gain control. This control is located on the projector control panel, at the left of the audio gain (volume) control. This control allows the operator to adjust the brightness of the white picture areas on the screen to obtain proper contrast.

From the video gain control, the video signal goes through coaxial cable to the video amplifier in the projector barrel located in the auditorium. Here the signal is amplified to high enough voltage to fully control the beam current of the 7NP4 projection Kinescope. This output voltage is then applied to the control electrode of the Kinescope, where it varies the current in the electron beam, and thus the brightness of the light spot on the Kinescope face, while this spot is being swept electronically across the tube face to produce the picture.

To enable the operator to see the picture before it is put on the screen, and to check on the operation of the video amplifier, a video monitor is provided on the monitor rack. This contains a 7-inch Kinescope, with associated equipment. A set of three interlocking pushbuttons is provided on the signal selector panel. Pushing the appropriate button connects the video monitor input to incoming line No. 1, incoming line No. 2, or, through a coaxial cable, to the output of the video amplifier in the projector barrel. The monitor Kinescope and the 7NP4 Kinescope in the auditorium projector therefore show the same picture.

Of course, if no video signal is being fed to the video amplifier, or if the amplifier for any reason is inoperative, the monitor will show this fact by lack of

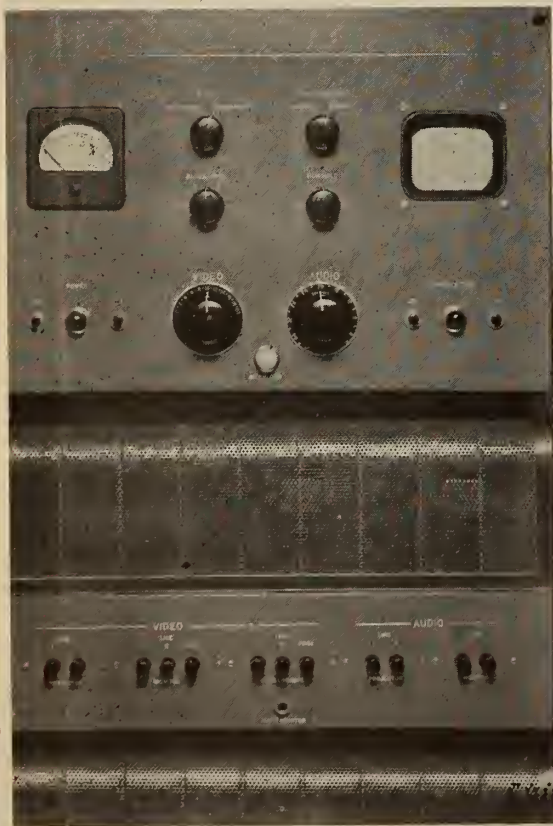

RCA PT-100 THEATER Tv UNITS
Top: Projector Control panel.
Bottom: Video-audio switching panel.

*The
Most
Popular
Spot*
On Earth!

The
STRONG TROUPER

High Intensity Arc Spotlight

is being used by theatres, night clubs, caliseums, arenas, stadiums, circuses, ice shows, schools, universities, colleges, TV studios, industrial shows and conventions.

Assures a sharp, steady, uniformly brilliant, dazzling snow-white spot. Draws only 10 amperes from any 110-volt A.C. convenience outlet. Adjustable, self-regulating transformer is an integral part of the base. No heavy rotating equipment necessary. Automatic arc control maintains a constant arc gap, free from hiss. Carbon trim burns 80 minutes at 21 volts and 45 amperes.

Silvered glass reflector. Two-element variable focal length lens system. Horizontal masking control angles 45° in each direction. Color boomerang contains 6 slides and ultraviolet filter holder.

Portable. Mounted on casters. Easily disassembled for shipping.



SEE THE TROUPER AT THESE DEALERS OR SEND COUPON FOR LITERATURE

ALBANY, N. Y.—Nat'l Theatre Supply Co.; Albany Theatre Supply
ATLANTA—Nat'l Theatre Supply Co.
ATLANTIC CITY—Boardwalk Film Enterprises
AUBURN, N. Y.—Auburn Theatre Equipment
BALTIMORE—J. F. Dusman Co.; Nat'l Theatre Supply Co.
BOSTON—J. Cifre, Inc.; Nat'l Theatre Supply Co.
BUFFALO—Dion Products; Nat'l Theatre Supply Co.
CHARLOTTE—Nat'l Theatre Supply Co.; Standard Theatre Supply Co.
CHICAGO—Abbott Theatre Equipment Co.; Gardner Jansen, Inc.; Hollywood Stage Lighting Co.; Midwest Stage Lighting Co.; Midwest Theatre Service and Equipment Co.; Nat'l Theatre Supply Co.
CINCINNATI—Nat'l Theatre Supply Co.
CLEVELAND—Nat'l Theatre Supply Co.
DALLAS—Hardin Theatre Supply Co.; Modern Theatre Equipment Co.; Nat'l Theatre Supply Co.
DENVER—Nat'l Theatre Supply Co.; Graham Bros.
DES MOINES—Nat'l Theatre Supply Co.
DETROIT—Nat'l Theatre Supply Co.
FORTY FORT, PA.—V. M. Tate Theatre Supplies
GREENSBORO, N. C.—Standard Theatre Supply Co.
HOUSTON—Southwestern Theatre Equipment Co.
INDIANAPOLIS—Nat'l Theatre Supply Co.
KANSAS CITY, MO.—Shreve Theatre Supply; Nat'l Theatre Supply Co.
LOS ANGELES—J. M. Boyd; C. J. Holzmüller; Nat'l Theatre Supply Co.; Pembrex Theatre Supply Corp.
LOUISVILLE—Falls City Theatre Supply Co.
MEMPHIS—Nat'l Theatre Supply Co.

MILWAUKEE—Nat'l Theatre Supply Co.; R. Smith Co.
MINNEAPOLIS—Minneapolis Theatre Supply; Nat'l Theatre Supply Co.
NEW HAVEN—Nat'l Theatre Supply Co.
NEW ORLEANS—Nat'l Theatre Supply Co.
NEW YORK CITY—Nat'l Theatre Supply Co.
NORFOLK—Nat'l Theatre Supply Co.
OKLAHOMA CITY—Nat'l Theatre Supply Co.; Oklahoma Theatre Supply Co.
PHILADELPHIA—Blumberg Brothers; Nat'l Theatre Supply Co.
PITTSBURGH—Atlas Theatre Supply; Nat'l Theatre Supply Co.
SALT LAKE CITY—Inter-Mountain Theatre Supply Co.
SAN FRANCISCO—C. J. Holzmüller; Nat'l Theatre Supply Co.; W. G. Preddey Theatre Supplies
SEATTLE—B. F. Shearer Co.; Nat'l Theatre Supply Co.

SIOUX FALLS—American Theatre Supply Co.
ST. LOUIS—City Electric Co.; Nat'l Theatre Supply Co.
TOLEDO—Theatre Equipment Co.
WESTERLY, R. I.—G. H. Payne Motion Picture Service
CANADA—
Dominion Sound Equipment, Ltd.
Montreal, Quebec
General Theatre Supply Co.
Montreal, Quebec
Perkins Electric Co., Ltd.
Montreal, Quebec
Perkins Electric Co., Ltd.
Toronto, Ontario
General Theatre Supply Co.
Winnipeg
Sharp's Theatre Supplies, Ltd.
Calgary, Alberta.

**THE
STRONG
ELECTRIC CORP.**
"The World's Largest Manufacturer of Projection Arc Lamps"
14 City Park Avenue
Toledo 2, Ohio

Please send free literature and prices on the Strong Trouper Spotlight.

NAME _____

COMPANY _____

STREET _____

CITY & STATE _____

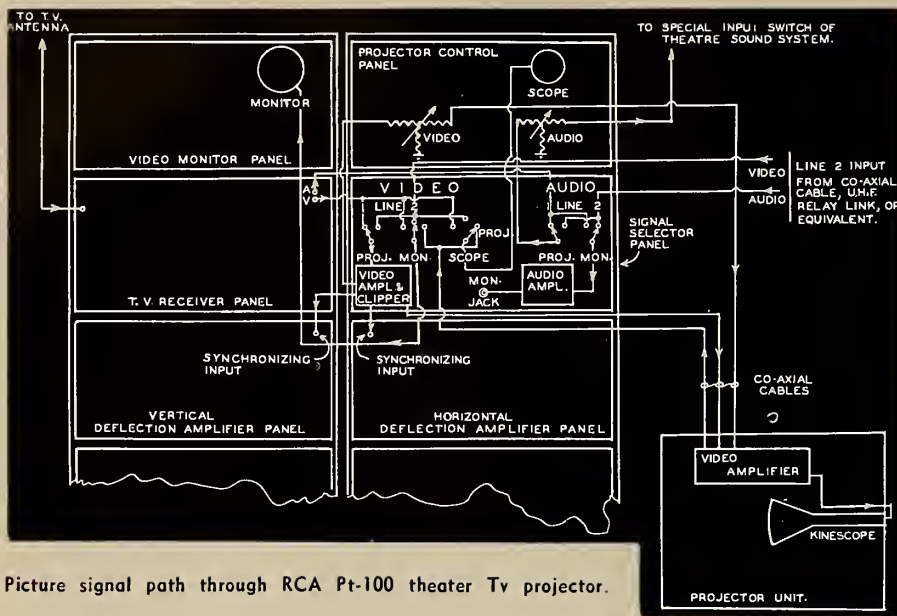

Picture signal path through RCA Pt-100 theater Tv projector.

picture when the projector button is depressed. This condition will, of course, be found to exist if the video gain control is set at zero.

Oscilloscope Input Check

An additional check on the video signal is always desirable and sometimes required. The incoming video signal must have a minimum value of one volt, peak-to-peak, in order to provide sufficient picture brightness. A 3-inch diameter standard oscilloscope tube, and associated circuits, is mounted in the projector control panel. The input to this oscilloscope may be obtained from input line No. 1, input line No. 2, or from the output of the video amplifier in the projector barrel, by means of another set of three interlocking pushbutton switches. However this 3-inch oscilloscope shows the waveform of the video signal, instead of converting it into a picture as the video monitor does. The height of this waveform pattern is proportional to the peak-to-peak value of the input voltage.

By turning the oscilloscope input control knob from "operate" to "calibrate," a one-volt peak-to-peak standard signal produces two horizontal lines on the face of the scope. The vertical distance between these lines will be the same as the vertical height of the video signal when its value is the required one volt peak-to-peak. Thus, either of the two incoming video signals, or the output of the video amplifier, may be quickly checked for proper voltage.

A built-in voltage reducer, or attenuator, reduces the high output voltage of the video amplifier to one volt before applying it to the oscilloscope or the monitor.

Part of the video signal is tapped off ahead of the video gain control. This part is amplified, "clipped," and its blanking pulses used to control the black-

level voltage at the projector. Its sync pulses are used to control the picture synchronization, and are applied to the vertical and horizontal deflection amplifiers. Here they serve to keep the vertical and horizontal beam deflection voltages in step with the corresponding voltages at the transmitter.

[The next installment of this series of six articles will deal with the manner in which the picture is formed and projected from the Kinescope to the screen.]

Kodak Liberalizes Pension Plan

Changes liberalizing certain parts of the Eastman Kodak Co.'s pension plan have been announced. They include:

- 1—Increased minimum payments.
- 2—A provision enabling women to earn greater pension credits.
- 3—Elimination of the former length of service requirement for pensions at age 65.
- 4—Supplemental payments under some conditions.

NEW MINIMUM PAYMENT: At least \$75 a month, plus social security, for those with 30 or more years' service if retired on or after Jan. 1, 1950. Those with less than 30 years will get an amount equal to \$2.50 per month for each year of service, plus social security.

Omit Service Requirement

SERVICE REQUIREMENT: For employees who reach 65 there will be no length of service requirement, regardless of how brief their time with the company. Thus every person hired before 65 may retire on the pension he or she has earned at 65. Previously, requirements were 20 years for men, 15 years for women.

SUPPLEMENTAL PAYMENTS: Under certain conditions Kodak will make extra payments to Kodak people already retired or who will retire in the future. In general these will be made when the rise in social security amounts to less than 25% of the company pension, and in certain disability and early retirement cases.

Standard 16-mm Travel-Ghost Test Film

Promulgated by American Standards Association

1. Scope and Purpose

1.1 This standard describes a method of determining freedom from travel-ghost in 16-mm sound motion picture projectors.

2. Definition

2.1 Travel-ghost is a blurring effect seen on the screen and evidenced by vertical tails or light streaks added to the projected images of the transparent areas on the test film. It is caused by the projector shutter being out of synchronism with the intermittent mechanism, either by faulty adjustment or faulty design.

3. Test Film

3.1 The test film used for determining freedom from travel-ghost shall carry a pattern of small transparent areas upon a dark background. There shall be at least six transparent areas, three of which shall be located not farther than 1/32 inch from the top of the frame, and three not farther than 1/32 inch from the bottom of the frame. Four of the areas shall have their edges 1/32 inch from a side edge and either the top or bottom edge of the frame. The density of the transparent areas shall be less than 0.2, and the density of the dark background shall be greater than 2.2.

3.1.1 *Standard Length of Film.* The standard length of test film shall be 100 feet.

3.1.2 *Leader and Trailer.* Each test film shall have a suitable leader, title, and trailer.

4. Test Method

4.1 A test film in accordance with 2.1 shall be projected at standard sound speed of 24 frames per second ($\pm 2\%$) upon a white matte screen, the projected image of the projector picture aperture being of such size that a screen brightness of 10-foot lamberts is obtained with the projector shutter running, but with no film in the gate. The screen image of the test film shall be viewed from a distance equal to twice its width, and the presence or absence of travel-ghost noted.

[NOTE: A test film in accordance with this standard is available from the Society of Motion Picture & Television Engineers.]

Typical travel-ghost pattern for 16-mm film, magnified about 8 diameters.



Carbon Arcs vs. Inkie for Non-Theatrical Projection

UNDER what conditions should arc-lamps, rather than incandescent filament lamps, be employed in motion picture projection? This question is in the minds of many of those in charge of films in the school and in the business worlds. Since there are so many borderline cases and unusual combinations of influencing factors, manufacturers have been reluctant to set down a formula for making final decisions.

However, the use of carbon arclamps has so enlarged the scope of usefulness of 16-mm picture projection, and the many advantages of this brighter light source have been so stressed, that a set of guides is definitely needed.

Just where should 16-mm projection and 35-mm projection be employed?

Any Conflict Unnecessary

First, there should be no conflict nor competitive situation between these two film gauges. In fact, the trend is to limit the use of 35-mm prints wherever possible. Many motion picture people deny this, however, maintaining that the narrower film does not offer enough detail for the larger size screens.

The big advantage of 35-mm film is that timely subjects (newsreels, documentary films, etc., are available to non-theatrical accounts much sooner than they can be had on 16-mm. In addition, schools may rent 35-mm entertainment pictures for projection in auditoriums at recess periods. This has been with the consent of theatermen in some locations, who feel that the exhibition does not really constitute competition to their established business or perhaps are afraid that refusal to waive such protection

By **HARRY H. STRONG**
Strong Electric Corporation

The intense brightness of carbon arclamps can greatly extend the use of 16-mm films. Larger audiences can attend showings, since a much bigger and clearer picture may be projected than can be obtained with incandescent lamps.

would result in bad public relations.

In any event, the school which elects to use inflammable 35-mm film must do so only in an auditorium where a fire-proof projection room is provided, never in a classroom. However, 16-mm film is non-inflammable and may be projected anywhere without restrictions.

For this and other reasons, interest has been mounting in the use of arclamps for 16-mm projection. Arclamps de-



Relative screen sizes that can be illuminated to the same brightness.

signed for 16-mm projectors are usually a smaller counterpart of the lamps employed in theaters. The arc lamps measure, in inches, about 23 by 13 by 13. They project five times the light of incandescent filament lamp equipment at less than one-half the operating cost!

When 1500 lumens of light are projected, brilliant pictures are possible in large-size screens and greater audiences can witness each showing. In fact, six times as many persons can attend if the room be large enough. Furthermore, the use of larger and brighter images on the screen "blows up" subject matter in pictures which would otherwise be indistinguishable on a smaller screen.

The switch from incandescent filament lamp projection to arclamps has been rapidly accelerating. Some schools already have classrooms and auditoriums which can accommodate this improved projection; while others are making pro-

visions for the changeover. Manufacturers are urging those who are planning new schools to have the architects include small projection rooms connected to each of the larger classrooms.

Determining Factors

The factors which determine whether incandescent filament lamp projection or arclamps should be used are: size of the room and the audience, ambient light, portability of equipment, simplicity of operation, and operating costs.

The illusion of reality in a picture presentation is best achieved when the screen is just large enough to be included in the normal viewing angle of the eye. A larger picture necessitates undue visual fatigue in following the action of the picture across the screen; while a smaller picture introduces the impression of remoteness. The result of the practical application of these principles is a picture having a width equal to one-sixth the distance from the screen to the back row of seats. For example, in calculating the correct screen size in a room 35 x 40 feet, where the rear row of seats is 36 feet from the screen, the picture should be 6 feet wide.

Because of aisles and areas where oblique viewing causes distortion of the screen image, the usable seating area of the room seldom exceeds two-thirds of the total floor area.

A 35 x 40 foot room with a floor area of 1400 square feet offers no more than 1000 square feet of usable seating space. Since about 10 square feet is required per person, this room will not seat more than 100 people for a screen showing.

Comparative Brilliances

The attainment of satisfactory results with 16-mm equipment requires a light source of sufficient power to afford a screen brilliancy comparable with that of commercial theaters. (Brilliancy is in direct proportion to the volume of light projected, and inversely proportionate to the area of the projected picture.)

An incandescent filament lamp projecting 300 lumens of light results in 10-foot-candles over the 30 square foot area of a screen 6½ feet wide, which just meets the accepted standard for pleasing picture brilliance.

Pictures larger than 7 feet wide re-

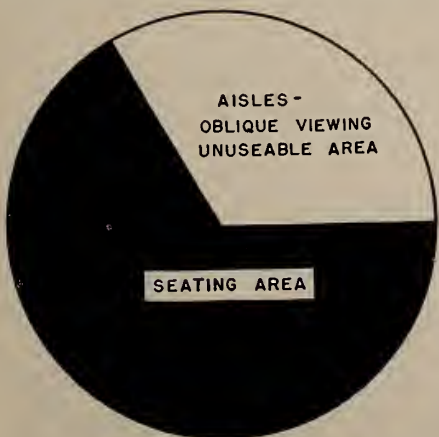

Typical division of room space.

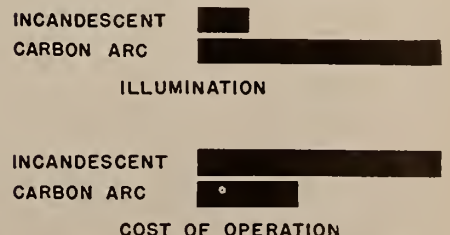

Comparison of illumination and cost of operation as between incandescent and carbon arc operation.

Viewing Distance from Rear Seat	Screen Width	Room Size	Total Area	Audience Size
24	4	23 by 28	650	40
36	6	35 by 40	1,400	95
42	7	40 by 45	1,800	120
54	9	50 by 60	3,000	200
72	12	70 by 80	5,600	375
90	15	85 by 100	8,500	575
108	18	100 by 120	12,000	800

quire a brighter light source than is obtainable with the incandescent filament lamp without sacrificing clarity. Accordingly, the use of an arclamp is required. The carbon arc projects 1500 lumens, or five times the 300 lumens projected by an incandescent filament lamp, and accordingly delivers 10 foot-candles of light over an area of 150 square feet, which is the area of a screen five times as large, or 15 feet in width. A screen of this size is large enough for an audience of 575.

The snow-white quality of the light projected by the high-intensity carbon arc gives a sparkling brilliance to the picture and imparts the illusion of even higher intensity, permitting a satisfactory projection of pictures as wide as 18 feet. A screen of this size is large enough for an audience of 800 people.

Other Important Aspects

From the foregoing formula and the available floor area, the seating capacity, screen size, and necessary light source may be calculated. Table I will aid in determining the requirements under various conditions. Where it is impossible to exclude extraneous light to attain an ideal darkness, as in many school auditoriums, the apparent brilliancy of the picture is reduced and more light must be projected. In many cases, it is necessary to use arclamps for projecting pictures even smaller than 6 feet in width.

In every installation the projection

distance depends on where the equipment can be located, and to attain the required picture size, a lens of the correct focal length must be used. If there is a choice of location, the projector should be placed at a distance from the screen that permits the use of a 2-inch focal length lens, because this standard size lens, which passes the maximum amount of light is a lower priced production item and is readily obtainable.

Although not as readily portable as the incandescent filament lamp projector for frequent moving from room to room, the carbon arc projector may be easily moved to out-of-the-way locations when not in use.

Carbon Arc Not Complicated

The carbon arc, as compared with the incandescent filament lamp, seems vastly more complicated to the casual observer. The truth is that the operation of the carbon arc is no more complicated than threading a projection machine. The expendable carbons are replaced easily and quickly.

Operating costs of the carbon arc are less than one-half that of incandescent lamp equipment, based on a cost of \$6 for an incandescent bulb having 10 hours life, or 60 cents an hour, as compared with a cost of 24 cents for a pair of carbons which burn one hour. This represents a saving of 10 hours of service weekly, or approximately \$200 a year.

Canadian Film Equipment Data

U. S. equipment has long predominated in Canadian theaters. While there has been no significant change during the past year, there has been a continuation of the trend toward manufacturing in Canada (often by U.S. subsidiaries) of a greater portion of the less specialized machinery; and, where equipment is partially manufactured in Canada, the tendency is steadily to give it more Canadian content.

The only foreign competitor of the U. S. in this field is the United Kingdom. British products are currently getting a slightly larger share of the Canadian market than formerly, owing to the price advantage they enjoy as well as the price-depressing effect of the devaluation of the pound in September, 1949.

Aggressive British Selling

Of course, the 117 theaters owned and operated by a British theater chain are almost entirely equipped with British projection and sound machinery. Canadian independent theater owners seemingly find the British equipment satisfactory, although the majority prefer the U. S. product.

Distributors of British equipment are intense and aggressive in their efforts to expand sales in this market!

The British share of the Canadian market is approximately 15%, and its outlook for expansion is favorable.

Equipment dealers had a good year in 1950. In fact, every year since the end of the war has been good. Responsible in a large measure for the favorable market for motion picture equipment during the past several years, has been the unprecedented theater building boom. From 1939 to 1946, construction of motion picture houses was rigidly restricted by wartime controls. Upon the termination of hostilities, however, restrictions on construction of places of amusement were among the first to be lifted, and theaters have been opened at a record rate since. From the beginning of 1946 to October 20, 1950, a total of 471 new theaters have been opened in Canada, 131 were under construction, and 126 were planned.

16mm Projector Lens Focal Length (distance from film to center of lens)	Distance in Feet from Screen												
	8'	10'	12'	20'	25'	32'	36'	40'	50'	75'	100'	125'	150'
	Width of Picture												
¾"	4'0"	5'0"	6'0"	10'0"	12'6"
1"	3'0"	3'9"	4'6"	7'6"	9'4"	11'11"	13'5"	14'11"
1½"	2'0"	2'6"	3'0"	5'0"	6'3"	8'0"	9'0"	10'0"	12'6"
2"	1'6"	1'10"	2'3"	3'9"	4'8"	6'0"	6'9"	7'5"	9'4"	14'0"	18'9"	23'5"	28'1"
2½"	1'2"	1'6"	1'9"	3'0"	3'9"	4'9"	5'4"	6'0"	7'6"	11'3"	15'0"	19'8"	22'5"
3"	...	1'3"	1'6"	2'6"	3'1"	4'0"	4'6"	5'0"	6'3"	9'4"	12'6"	15'7"	18'8"
3½"	...	1'0"	1'3"	2'1"	2'8"	3'5"	3'10"	4'3"	5'4"	8'0"	10'8"	13'4"	16'0"
4"	1'1"	1'10"	2'4"	3'0"	3'3"	3'9"	4'8"	7'0"	9'4"	11'8"	14'0"

This table is a handy guide in determining the type of lens required to project pictures of different sizes at various distances. For example, in a room where the projector is set 10 feet from the screen, it would be impossible to obtain any picture by using a lens having

a focal length of 4 inches. However, in an auditorium where the distance from the projector to the screen is 150 feet and the screen width is 14 feet, the same lens would be ideal. Other factors, of course, contribute importantly to over-all optimum results.

THE theory of projection optics, simple at first thought, complex in fact, has been made bewildering by misconceptions entertained even in high projector-manufacturing circles. It seems incredible that any manufacturer should be guilty of crass ignorance concerning a technical subject which has been reposing on his own doorstep for quite a number of years.

A sound knowledge of projection equipment is built upon an acquaintance with the mechanical, optical, and electrical fundamentals involved in the functioning of that equipment. Now that the art of projection has passed the half-century mark, it would seem that the optical theory of projection would be an old, old story to everyone. Recent contributions touching upon this subject, however, lead us to believe that such is not the case.

As Larry Davee* points out (IP for October, 1950, p. 12) a motion picture lens, even though complicated by several glass elements inserted for the purpose of correcting chromatic and spherical aberration, works exactly the same as a simple lens. Because this is true, we can employ single-element lenses in diagrams intended to illustrate the principle of projectors and cameras.

Pickup From Every Point

Figure 1 illustrates optical projection under the most simple conditions. The "object" (film-photograph or lantern slide) is evenly illuminated by light from an ordinary bulb. A ground-glass plate is interposed between the bulb and the transparent picture in order to insure perfect diffusion of the light.

It will be readily appreciated that light from every point of the picture is picked up by the entire surface of the projection lens and thrown onto the screen to form an enlarged image. It may be seen also that the lens inverts the image, hence the picture must be placed upside-down in the projector in order to show right-side up on the screen.

The paths of the light rays which determine the boundaries of the beam emerging from the lens are indicated

* Century Projector Corp.

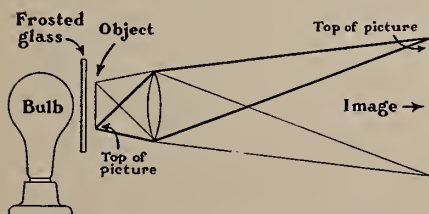

FIG. 1. Optical projection under the simplest conditions. Because the illumination is diffused by the frosted glass, no secondary image is formed between the lens and the screen. Inexpensive photographic enlargers have this type of optical system.

This 'Mysterious' Aerial Image

By ROBERT A. MITCHELL

by straight lines. The beam, therefore, has its smallest diameter close to the lens.

Figure 1, however, does not represent the optical conditions peculiar to the standard motion picture machine!

Factual Optical Conditions

In motion picture projection, the illumination is furnished by a mirror

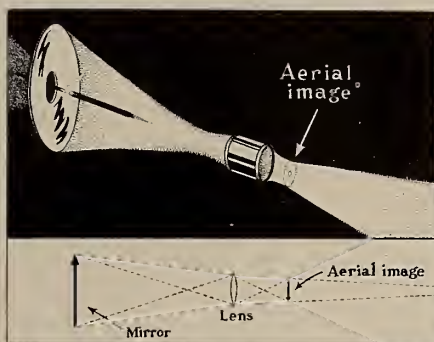

FIG. 2. The formation of a reduced image of the mirror—an "aerial image"—in front of the lens of a motion picture projector.

or condenser of limited size placed at a considerable distance behind the projector aperture. Although we seldom give it a thought, the mirror, itself, is an "object" which is "imaged" by the projection lens. Because the distance between mirror and projection lens is greater than the focal length of the lens, the image of the mirror must be a reduced image. And it must lie somewhere between the lens and the theatre screen.

The projector, therefore, forms two optical images at the same time: an enlarged image of the film on the distant screen, and a reduced image of the mirror only a few inches in front of the lens.

In forming an image of the mirror, the projector acts just like a snapshot camera pointed at the moon. The camera lens brings all the rays it receives from the moon to a focus on a film or plate. And because the distance of the moon from the camera lens is much greater

than the focal length of the lens, the image of the moon is vastly smaller than the actual size of the moon.

All this is very obvious, indeed; but it must especially be emphasized that the camera lens (if it be a good one) does not scatter and lose any of the moon's rays, but collects all of them into an image of the moon. No moonlight will fall anywhere on the plate except within the boundaries of the little moon image.

Orienting the Aerial Image

So it is with the movie projector. All of the light which reaches the lens from the mirror must be collected into the little mirror image which hangs unseen in space from 2 to 4 inches in front of the lens barrel. To see this "aerial image" of the mirror one need only hold a piece of cardboard—preferably dark—in the plane where the aerial image is formed. The hole in the mirror and the positive carbon support will be clearly visible, though the image is upside-down.

The cardboard is then strictly analogous to the plate of the camera photographing the moon. Fig. 2 shows what the light-beam would look like if all of the projector except the arc mirror, carbons, and projection lens could be made invisible. The optical diagram immediately below this picture indicates how the rays form the aerial image in front of the lens.

Is it not as plain as day that no light reaches the theatre screen from the projector except that which has passed through the aerial image?

Figure 1 cannot represent the actual paths of the light-rays because no aerial image is formed under the conditions of perfectly diffused illumination. We cannot merely substitute an arc mirror for the bulb and frosted glass, as in Fig. 3, and get a true diagram.

In fact, Fig. 3 is completely false, as may be gathered from the various question-marks which indicate our skeptical state of mind. From what source of illumination, we ask, do the rays indicated by the heavy dotted lines come? Certainly not from the arc-lamp mirror, because the mirror sub-

(Continued on page 28)

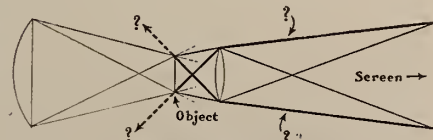

An "Optical Booby-Trap"

FIG. 3. You won't win a prize by finding the errors in this diagram, but you'll find out how even experts have been tripped up by projection optics. See text for the solution of this puzzle.

IN THE SPOTLIGHT



By
**HARRY
SHERMAN**

THIS department accords top priority for this issue to a topic which has been the subject of considerable private and union-meeting discussion among IA members during the past several years—the institution of some form of welfare plan for the organized workers in the amusement crafts.

Oddly enough, while the stage employes, whose members generally are older men, were most vocal in pressing for welfare plans, it remained for a projectionist unit—Local 110 of Chicago—to put the lid on the stove, so to speak, and conclude the first hard-and-fast complete welfare coverage for its members.

Much valuable data on employe welfare plans is contained in a brochure issued recently by Bankers Trust Co., of New York, which is already administering pension plans for nearly 200 leading commercial and industrial organizations. This report indicates, we think, certain definite trends in welfare plans which are worthy of summarization here.

The report contains two sections: one dealing with what are termed “unilateral” plans which are instituted and administered by the employer, and the “negotiated” plan which is a matter for agreement between the employer and the union and is usually administered jointly. Of late, unions have shown a strong

preference for the negotiated plan, particularly with respect to its administrative feature.

Quite apparent in both plans within the past two years has been the trend toward a liberalization of eligibility requirements as to age level and years of service. A great majority of the plans, whether new or already in effect, have been liberalized by an average of five years on both these counts. While 65 years of age continues to be the retirement level for a great majority of plans now in effect, there is every indication that amendments lowering this figure by five years will be effected. Service requirements average out at about 25 years, although many plans provide for a lesser payment pro rata upon earlier retirement.

In the negotiated plans the pattern has been such as to establish standard retirement benefits. The \$100-a-month benefit, including Social Security payments, has become practically standard in negotiated plans in which the employer pays the entire cost. This assumes that the employe retires with 25 or 30 years of service and was paid at a rate not in excess of \$3500 per year.

Most plans deduct, in addition to Social Security benefits, payments received by the employe from “other sources,” such as other pension plans to which

the company may have contributed, dismissal and unemployment payments, and similar benefits to which he may be entitled.

The steel, rubber and aluminum plans have no compulsory retirement provision and allow an employe to work as long as he is physically able. The other patterns provide an automatic or compulsory retirement age, but two permit the employer to retire workers (except for inability to work efficiently) as early as age 65. In several of the plans having this compulsory or automatic feature, the employes who were over or close to that age on the effective date are not being forced to retire immediately but are being permitted to continue work for periods of up to five years.

All of the plans include a provision for disability benefits, most of which are limited to total and permanent disability, and no benefit is provided for disability of a temporary or partial character. Benefits in most of the plans do not start until total and permanent disability has been established over a six-month period.

Of course, practically all the data contained in the Bankers Trust Co. report applies to industries which are of a totally different character from that of the amusement field. While there are many instances where an amusement worker may stay on one job for one employer for a long span of years, there are countless other instances where the worker may have anywhere from five to ten different employers over a period of years. This is particularly true of studio workers and of stage employes, with a given job lasting only for the duration of production or for the run of the show. Projectionists are on a somewhat more stable basis.

On this basis, it would seem that benefit plans for IA workers could hardly ever be satisfactorily negotiated on a national scale, and certainly not on the basis of including all the various crafts with widely fluctuating terms of employment. Of course, there is the possibility of writing into every IA contract, irrespective of for what craft, a provision for payment of a certain percentage of total wages into a general welfare fund. Such a plan would necessitate exclusive con-

NOTABLES PRESENT AT THE INSTALLATION OF 25-30 CLUB OFFICERS FOR 1951



Left to right: Walter Green, president, National Theater Supply Co.; Harry Sherman of IP; Admiral R. B. Tampkins, president, International Projector Corp; Allen G. Smith, N.T.S. New York branch manager; B. Passman, chief engineer for I.P.C., and Arthur Meyer, vice-president and general sales manager of I.P.C.

trol of the funds thus accumulated by the union, probably the General Office—which would pose a terrific administrative problem.

Craft, Area Likely Basis

Overall, it seems practically certain that any benefit plan for IA workers would have to be negotiated on the basis of craft and local area, much after the pattern of the Chicago Local 110 set-up. Moreover, it seems equally certain that administration of such benefit funds would have to be vested solely in the union, in view of the character of the work performed by its members.

The foregoing data is offered solely to stimulate thinking on the part of IA craftsmen and in the hope that it may help to "jell" the craft's thinking anent this extremely important topic.

- The prolonged strike of San Antonio Locals 76 and 407 against the Zaragoza Amusement Co. came to an end last month with the signing of contracts between the circuit and Local Union officials. Intensive picketing and court actions marked the 21-month deadlock between these groups, and the final settlement of this dispute is a signal victory for the union. The Alameda Theatre is the first in the Zaragoza chain to employ union projectionists—three men, each man to receive \$85 per week, two weeks on and one week off, with a \$5 per week increase to become effective in six months.

Ernest (Frenchy) Biencourt, Roy Cogdill, business representatives for Locals 76 and 407, respectively, and Henry Van Archer, attorney, represented the union in the negotiations.

- Tom Canavan, brother of former IA President Bill Canavan, was once more elected a delegate to the Variety Club national convention, representing St. Louis Variety Tent No. 4.

- History has a way of repeating itself. Five sons of Bill Thompson, popular business representative for Pittsburgh Local 171, served with our armed forces during World War II. Recently, his youngest son, Richard, was inducted into service, and another son, Robert, is stationed in Kentucky.

- IA President Richard Walsh emphatically denied a statement, attributed to him by a widely-read theatrical weekly, that projectionist Local Unions throughout the country are "for the most part satisfied with their present scales and are not likely to be coming up with new demands." At a recent press conference, President Walsh, in response to a query by a reporter for the weekly, said that no drive for projectionists' wage increases was being made by the General Office because *each Local has the right to negotiate its own contracts.*

Walsh said that his statement, as it appeared in the weekly, was misquoted, was untrue and harmful; that "if we ever reach the time when groups of employees, or employers, in America really do stop striving for a better income, then we may be sure that this country we have loved and believed in has started to decline." The IA leader asked that the trade press generally publish an accurate statement of his views.

- As an aftermath to the trial and conviction last year of the 11 top national Communist leaders, Harry Sacher, one of the defense attorneys, was ousted as attorney for New York Local 306, a post he has held for the past several years. The retention of Sacher as counsel for Local 306 had long been the subject of hot debates in and out of the meeting rooms, and a vote taken at the January 3rd meeting culminated in his ouster. Sacher was attorney for a number of unions in and around New York City, and his dismissal from Local 306 is one of several in the past few months.

- An amicable settlement reached between IA Representative Eddie Miller, who is also business representative of Houston Local 279, and Julius Gordon, president of East Texas Theatres, Inc., ended the 120-day-old strike of projectionists in the Baytown area. Picket lines were withdrawn and the projectionists returned to work.

- Congratulations to our very good friends, Nettie and Hector Stewart, Buffalo Local 233, who celebrate their 22nd wedding anniversary on Hector's 56th birthday, January 25. Hector's membership in the Local dates back many years, and we know that the double celebration will be a very joyous one for the Stewarts.

- The TMA (Theatrical Mutual Associations) will hold its 32nd biennial convention at the Neil House, Columbus, Ohio, July 9-11 next. The installation of officers and a dinner party will be held on Wednesday, July 11.

- The IA Executive Board will hold its mid-winter session at the Santa Rita Hotel, Tucson, Arizona, the week beginning February 5.

- Completing 30 years of service, Jack Hauser resigned from the office of business representative for Local 96, Worcester, Mass. However, he is still working at the Poli Theater, where he has been employed for many years.

- The AF of L lost a grand old man when Joseph N. Weber, 84, president emeritus of the American Federation of Musicians, died last month at his home in Beverly Hills, Calif. Joe Weber held

the office of president of the musicians' international union for 40 years, until his retirement in 1940. His union worked in close cooperation with the IA back in the days of Charlie Shay and Bill Canavan, and many a time Weber pulled his men out of theaters and kept them out until IA contracts were signed. Our organization cooperated in the same manner.

Joe Weber celebrated his 59th wedding anniversary September 1950, and at the AF of L 69th convention in Houston last September he was called to the convention platform where he was congratulated by President Green and was given an ovation by the delegates.

Ten-Year Film Theater Data

Motion picture theaters in the U. S. reported receipts, including taxes, of \$1,569 million for 1948, a gain of 133% over the 1939 figure of \$673 million, reports the U. S. Dept. of Commerce. Data for drive-in and portable motion picture theaters are not included in these figures. The total number of film theaters increased from 15,115 in 1939 to 17,689 in 1948, an increase of 17%. Individual theaters doubled their dollar volume of receipts, the average establishment taking in \$88,693 in 1948, compared with \$44,528 in 1939.

Employment in motion picture theaters increased from 128,857 to 181,322 for the workweek ended nearest November 15 in both Census years. For the country as a whole, annual payroll in theaters rose from \$132 million in 1939 to \$295 million in 1948. Employees shared in the industry's growth with their average annual wage (full and part-workweek combined) increasing from \$1,021 to \$1,625 during the period 1939 to 1948.

Dollar Volume Soars

Increases in dollar volume of receipts were general throughout the country and a larger number of theaters was recorded by most States. The largest increases in receipts were reported by Florida (251%), Alabama (208%), and Arkansas (205%). Mississippi, Arkansas, and Alabama led the Nation in gains in the number of theaters for 1948 over 1939, reporting increases of 69%, 68%, and 58%, respectively.

New York, California, Pennsylvania, and Illinois, each reporting motion picture theaters receipts in excess of \$100 million in 1948, accounted for 25% of the number of establishments, 39% of the dollar volume, and 42% of the payroll of the entire country for this industry. Comparable figures for these same States in 1939 were 26%, 41%, and 42%.

Westrex Corp. Personnel Busy

Reeve O. Strock, recording manager of Westrex Corp., subsidiary of Western Electric Co., has returned to the New York office after a world-wide trip concerned with sales, engineering and general contact work. Latest Westrex installation is a new sound recording unit at Bell Productions & Television Films, in Miami, Fla.

Brush-up on Fundamentals

II. CAPACITANCE. Another in the series of articles designed to serve as a refresher course in certain technological fundamentals and their application to new equipments and processes which may be utilized in the motion picture theater field in the near future.

CAPACITANCE, which is manufactured commercially and is known as a condenser, is equally important in radio as is inductance. Not all capacitance, however, is found in the form of commercial units; sometimes it exists between certain radio components. More often than not such capacitance results in poor performance in a radio receiver and steps are taken to eliminate or reduce it. Capacitance of this kind is known as "stray capacitance."

Whenever two conductors of electricity are separated by an insulator, a condenser is created. The insulator in a condenser is often called a "dielectric." The dielectric may be a vacuum, air, glass, mica, waxed paper, oil, ceramics, or a chemical deposit such as aluminum oxide. The conductor is usually constructed of steel, aluminum, tinfoil, brass, or metallic paint.

Condenser types usually are designated with respect to the kind of dielectric that they contain. For example, a paper condenser contains a paper dielectric, and a mica condenser contains a sheet of mica as the dielectric.

Action of a Condenser

The action of a condenser will now be considered. Let us suppose that a condenser is connected, as shown in Fig. 1. This is a series circuit consisting of a condenser, a battery, a zero center scale galvanometer which reads to the right or left, depending upon the direction of current through the meter (similar to an ammeter in an automobile), and a switch.

When the switch is open the condenser does not have any charge on it; and when the condenser is not charged it is said to be in a neutral state. At the instant that the switch is closed, electrons rush from the upper plate of the condenser into the positive terminal of the battery. It should be remembered that a battery is a source of electrical pressure and is capable of forcing free electrons to move. The positive terminal of the battery is

deficient in electrons. When it is connected to the condenser it will draw some free electrons from the plate of the condenser to which it is connected.

The negative terminal of the battery has an excess of electrons. These excess electrons will now move into the lower plate of the condenser because this plate is connected to the negative terminal of the battery. The direction of electron flow is indicated by the arrows in Fig. 1, and because electrons flow through the galvanometer it will give an indication.

The atoms which make up the condenser have been disturbed from their neutral condition due to the transfer of electrons from one of the plates to the other. This disturbance will create lines of electrostatic force between the plates of the condenser, and these lines of force result in a dielectric field between the plates.

Storage Characteristics

All condensers are capable of storing a certain amount of electrical energy (dielectric field) depending upon their capacity (size). When the condenser in Fig. 1 has stored all the energy of which it is capable, the electrons in the circuit will cease to flow. The condenser is then charged to the same voltage as the battery, and the circuit is similar to one which contains two batteries of equal voltage in parallel. In practice, it takes only a fraction of a second to charge a condenser to the voltage of the charging source.

Because the flow of electrons is only in evidence for a very short period of time, the galvanometer will act in the following manner. At the instant the switch is closed the needle of the meter will kick to the right and then return to zero. This indicates that the current in the circuit flows for only a very short period. If the battery were now removed from the circuit the dielectric field would still remain.

Effect of Closed Switch

Theoretically, the field should remain indefinitely if the condenser is not disturbed. In practice, however, the field deteriorates rapidly when the battery is disconnected, because the electrons which have left the upper plate of the condenser desire to return to it and will do so by leakage through the dielectric or through the air.

Figure 2 is very much like Fig. 1,

except that now the battery has been removed from the circuit. When the switch is open the dielectric field still exists between the plates of the condenser. Let us suppose that the switch in Fig. 2 is closed. The electrons from the lower plate of the condenser will now return to the upper plate from which they came originally. The direction of current in the circuit has now reversed from that in Fig. 1, and the meter will kick to the left and then return to zero when all of the electrons have returned to the upper plate.

The condenser is now said to be discharged and the dielectric field will disappear completely. Although the electrons have moved in the circuit, none have actually passed through the condenser, because the plates of the condenser are separated by an insulator and the electrons cannot move through an insulator.

When D.C. is impressed upon a condenser, current flows in the circuit for only a fraction of a second and then becomes zero. Because current flows for only a fraction of a second, it is said that D.C. does not allow current to flow in any circuit which contains a condenser. As we shall see a little later, A.C. will allow current to flow in a circuit that contains a condenser.

Filter Condensers

A condenser is very useful in radio circuits for separating direct currents from alternating currents. A condenser has a smoothing effect when placed across a direct current that is varying slightly in amplitude (pulsating D.C.) and these condensers are commonly used in the power supply section of radio receivers. In this application, they are known as "filter condensers."

When an exciter lamp in a motion picture projector is operated from rectified A.C., a great deal of filtering is necessary in order to remove the 60-cycle hum which would show up in the sound. Large con-

FIG. 1. Charging a condenser.



FIG. 2. Discharging a condenser.



condensers are used for this purpose. Whenever circuits which contain a large amount of inductance are opened, a great deal of sparking results at the switch contacts. This is true of D.C. circuits which feed motors, generators, spark coils, relays, and automobile ignition systems.

Since inductance tends to keep the current flowing when the switch is opened, a hot spot develops on the switch contacts. This hot spot burns the contacts and carries away from them small particles of copper. This action results in premature wear on the switch and lowers its efficiency as a switch because of pitted contacts. If a condenser is placed across the switch contacts, the condition is soon remedied. The reason for this is that the energy set flowing by the inductance in the circuit charges the condenser and eliminates sparking.

Condenser Size Factors

The amount of energy that the dielectric field of a condenser can store depends upon the size of the condenser—the larger the condenser, the greater the energy. The size of a condenser depends upon four factors:

- (1) The area of the plates facing each other.
- (2) The number of plates that are connected in parallel.
- (3) The distance between the plates or the thickness of the dielectric, and
- (4) The type of dielectric used.

If the quantities in the first and second factors listed are increased, the capacitance of the condenser will increase, as will its ability to store energy. If the distance between the plates were increased, the capacitance would decrease because the concentration of the dielectric field would be less dense.

The type of dielectric used in a condenser is very important in determining its size. The atomic structure of some dielectrics is such that they aid the dielectric field more than others when an electrical pressure acts upon them. This quality has been designated as the "dielectric constant."

The dielectric constant of air is 1, and the dielectric constants of other materials differ widely. Mica, for example, has a dielectric constant of approximately 6. Let us see what significance this has. It means that if an air condenser has a certain capacitance and if mica were substituted for air, the capacitance of the condenser would increase six times.

Dielectric Strength

The dielectric strength of an insulating material is the minimum value of electric field intensity required to rupture it. Dielectric strength usually is expressed in kilovolts per centimeter of dielectric thickness. Heating of the dielectric leads to rapid deterioration, particularly if

moisture is present, and ultimate breakdown. Most dielectrics will withstand a much higher voltage for a very brief period than voltage applied for a longer period.

These effects have dictated two tests for condensers: a high flash-test voltage of very brief duration, and the application of a much lower voltage for a longer period.

If too large a voltage is impressed upon a condenser, its dielectric may be pierced by a spark which jumps through it. In condensers using paper, mica, or glass as the dielectric, the puncture of the dielectric by too great a voltage will prove fatal and will render the condenser useless for radio work. A condenser using oil, a wet electrolyte (borax solution),

or air, will heal itself after the excessive voltage is removed. This excessive voltage is known as the "breakdown voltage."

Condensers should never be operated with such a high voltage across them. The safe voltage which may be impressed across a condenser is called the "working voltage." Lower voltages may be used, but voltages higher than the working voltage should never be used for more than a brief period.

A condenser can be made to withstand very high voltages by increasing the thickness of the dielectric, but this is not always feasible because the capacitance of the condenser decreases as the thickness of the dielectric increases. In order
(Continued on page 26)

The Ashcraft Hydro-Arc Lamp

COVERING a wide range of operating current, the new Ashcraft Hydro-Arc lamp has proved its flexibility under actual field conditions, whether used in the larger enclosed theaters or for the medium-sized drive-ins. The lamp was designed when it became apparent that many exhibitors were attempting "conversion" of existing lamps, with badly mismatched optical systems, in an effort to obtain increased light output.

The Hydro-Arc permits the easy exchange of reflectors and carbon jaws, depending upon the light output desired: a 15-inch reflector is standard equipment with the 9-mm carbon, while a 14-inch mirror is used with the 8-mm carbon. A large lamphouse helps overcome the problem of excessive heat.

Wide Current Range Possible

When the 9-mm carbon is used, the Hydro-Arc utilizes water cooling for the carbon jaws. This unit is not used when 8-mm carbons are employed. Only three-fourths of a pint of water per minute flows through the cast bronze jacket surrounding the carbon to cool both the

shoes and carbon. Rated capacity for the Hydro-Arc is 80-85 amperes with the 9-mm carbon, and 60-75 amperes with the 8-mm carbon.

Erratic positioning is avoided when manual reflector adjustments are made because of its mounting in a heavy cast aluminum ring which is swiveled to the back plate by means of a large ball and socket. The negative carriage is slide-mounted in a heavy cast aluminum housing which may be moved vertically or laterally on the compartment separation baffle by external controls for negative carbon tip positioning.

The entire arc control—feed motor, rheostat speed control, gearing and negative cam levers—is constructed as a unit and is placed vertically on the rear left-hand side of the lamphouse casting. All shafts operate on precision roller bearings to eliminate friction and wear. The motor is equipped with angular ball thrust bearings.

More detailed information anent the Hydro-Arc is available from C. S. Ashcraft Mfg. Co., 36-32 Thirty-Eighth St., Long Island City 1, New York.

Exterior view of Ashcraft Hydro-Arc as viewed from the rear and showing the outside positioning of the entire arc control assembly.



New Technicolor Lighting System Tested by Top-Flight Cinematographers

Rigid tests of new color filming system have been completed in five major Hollywood studios, according to the appended report by *American Cinematographer*. Sharp gains in economy and photographic quality are seen, based on preliminary tests of this new system.

By LEIGH ALLEN

FOLLOWING the general announcement by Technicolor of its new low-light level photographic system, a demonstration of some of the tests photographed by five Hollywood studios with the new system was given recently before members of the American Society of Cinematographers. The test footage screened was photographed by director of photography Charles Roshier, at M-G-M studios; by Arthur Arling, at 20th Century-Fox studios; and by Charles Boyle, at Universal-International studio.

Initial photographic research on the system began at M-G-M under the direction of John Arnold. One of the largest single users of Technicolor, this studio considered it to their interest to explore the possibilities of materially reducing photographing costs when filming in color, a substantial item of which involves the lighting and set operation time required to place the great number of lighting units normally used. The "old" method of Technicolor photography demanded a working illumination of around 400 to 500 foot-candles.

The objective was to find a means for shooting Technicolor using, if possible no more light than is generally used for black-and-white pictures. To accomplish this would mean that the studios would be able to produce more pictures in Technicolor without materially adding to production costs. The main objective at the beginning, according to Arnold, was to develop a system that would enable studios to photograph Technicolor interiors entirely with low-level, unfiltered incandescent light instead of arc light.

This led first to a revision by Technicolor in the emulsion characteristics of the film used in the camera, a step which led naturally to the next—an important technical change in the optical system of Technicolor cameras. The final major step involved changes and improvements in the Technicolor film processing procedure. Thus, the whole new process involves and depends upon a chain of improvements, each dependent upon the other.

For the director of photography, the

new Technicolor system involves no important change in procedure other than the use of incandescent instead of arc light, as at present. Most of those present during screening of the test films expressed the view that the new Technicolor system rendered a more pleasing overall tone, less harsh than the current system.

Adequate Light, Well Distributed

The tests photographed by Roshier consisted of three sequences of scenes staged and directed by George Sidney, and utilized three different sets. The first was a bedroom scene in which a girl enters, bids her escort goodbye at the door, then retires, turning out the room lights

so that the only illumination is that filtering through the windows from out of doors. The keylight for this set was 100 foot-candles. With regular Technicolor it would have been 400 foot-candles.

When the room lights were extinguished, the keylight dropped to 30 foot-candles in the closeup of the girl. At all times the illumination is adequate, well distributed, and obviously carries to the depths required by the set.

The second set was a low-key church interior. The girl is kneeling before the altar and facing the camera. Camera alternates between closeup and medium shot. Keylight for this sequence was 75 foot-candles. A marked pictorial effect was that of the vari-colored light from the stained glass windows falling on the floor of the church behind the girl.

The third set was a full day exterior of a garden with the girl singing—first in closeup, then in medium and long shots as she alternated between dancing and sitting on the garden wall. Keylight for these shots was 100 foot-candles with cross lights of 125 foot-candles.

Color Temperature All-Important

According to Roshier, he began these tests on a purely experimental basis, proceeding on the basis that color temperature was all-important with the new system. "Color temperature must be correct in the light falling on faces," he

Projectionist Examination Questions

Based on Examinations by Leading U. S. Municipalities

1. Having a circuit 1000 feet long carrying 60 amperes with a voltage drop of 8%, the circular mil area is 33,100, the voltage is 110. What is the resistance of the circuit?

2. Having a 220-volt source, four Mazda lamps are connected across it with resistances of (a) 100 ohms (b) 200 ohms (c) 300 ohms, and (d) 400 ohms. What is the amperage of each lamp. Of each circuit? What amperage would they draw if they were one lamp?

3. If you had three resistances of 3.25 ohms, 4 $\frac{3}{4}$ ohms and 5 ohms, what is their combined resistance in series? In parallel?

4. If you had three condensers of 2 mfd, 6 mfd and 4 mfd, what would be the capacitive reactance if they were connected in parallel?

5. A 50 H.P., 440-volt motor has a full-load efficiency of 92% and a power factor of 0.8. How much current is required for single phase? Two phase? Three phase?

6. A 50 H.P. single-phase, 440-volt motor having a full-load efficiency of 92% and a power factor of 0.8 is to be operated at a distance of 1000

feet from the alternator, the wires are to be spaced 6 inches apart, the frequency is 60 cycles with a 5% loss. Determine the electrical H. P., the watts, the apparent load, size of wires, voltage drop, and voltage at the alternator.

7. Give the allowable current carrying capacity of at least five different sizes of wire with which you are familiar.

8. What size wire should be used for from zero to 100 amperes, 101 to 200 amperes, 201 to 500 amperes, and for over 500 amperes?

9. How would you change the direction of rotation of a three-phase A.C. induction motor?

10. How many volts are lost in a circuit carrying 120 amperes and having a resistance of 1/30 of an ohm? What wire size would be required for such a circuit if it were 400 feet long?

11. How would you wire four 25-ampere rheostats on a 220-volt source so as to get approximately 60 amperes at the arc?

12. Why is D.C. preferred over A.C. to supply projection arcs?

said, "regardless how it is elsewhere on the set. If color temperature in other parts of the scene is slightly up or down, it is relatively inconsequential."

Implementing the incandescent lamps were spun glass diffusers and frosted gelatins. Arnold, in preliminary photographic tests with the new Technicolor system, had already established the fact that China silk diffusers often prove detrimental because of their tendency to bleach and burn, thus changing the color temperature of the light.

The sequences of tests photographed at Fox by Arthur Arling were made on three different sets. Arling's aim was to put the new system to test following customary production routine. Thus he chose scenes and setups approximating those normally used in regular Technicolor production.

Fox Tests of High Artistry

The first set was a night interior of a living room in which a girl and young man meet. The camera ranges from closeup to medium shots. The keylight registered 125 foot-candles. The action was repeated and photographed several times, each time with the illumination setup altered slightly but without changing the keylight level.

The second sequence of shots elicited considerable comment for their lighting artistry. The set was a full night interior of a bedroom with soft moonlight falling on a window at the rear. A girl on a couch, turns out the room light, arises and goes to the window where she opens the shutters, admitting moonlight. For this scene a keylight of 150 foot-candles was used. This dropped to 100 foot-candles when the room light was extinguished. An arc with four scrims was used back of the window for the moonlight effect in the closeup of the girl at the window; for the medium shot of the moonlight effect, a Senior was used with a Macbeth filter.

The third sequence was a full-lit day interior of a living room with shots ranging from medium to closeup. Here again, the keylight was 150 foot-candles.

"These initial tests," said Arling, "prove the great need at this time for a good 1000-watt CP incandescent globe. For the new Technicolor system, the present 2000-watt globes are too powerful, requiring diffusion to cut down illumination intensity. With the 1000-watt lamp we could dispense with diffusers and get correct color temperature and light intensity at the same time."

Filtering Losses Regained

"When we filter incandescent lamps for regular Technicolor," he added, "we lose 60% of the light. With the new system, using incandescent light, we gain back this lost 60% and have the advantage of the full 100% of the lamp's

National Carbon Reduces Copper Coating as a Defense Aid; Operating Amperage Cut

National Carbon Co. has moved swiftly to cooperate with the Government in its attempt to conserve copper for strategic defense needs, as outlined in Copper Order N.P.A. M-12, which calls for a reduction in copper for non-military needs.

In order to provide an adequate supply of carbons and, at the same time, cut copper usage, the thickness of the copper coat is being reduced in two of the most popular projector carbon trims. This action is similar to the measures taken during World War II, and these carbons will again be known as "Victory" Carbons. They will be identified by white ink showing the trade-mark and the five-ampere reduction in the maximum current rating to:

potential illumination. Where arcs are used with the new Technicolor system which requires use of filters, resultant light loss from filtering is around 30%—an amount easily expendable."

The test sequences photographed by Charles Boyle at U-I consisted of wardrobe and makeup tests. The takes ranged from closeups to medium shots, with an occasional two-shot, and were filmed with a keylight of 150 foot-candles. All illumination on the sets was by 2000- and 500-watt globes of 3450 K temperature. Spun glass and frosted gelatin diffusers were used. An incandescent broad was used with a silk diffuser.

Commenting upon the new system, Boyle said: "It is the most important development in Technicolor's history. After shooting Technicolor for 13 years, I just couldn't believe that such results were possible until I tried it. Working with Technicolor with a keylight of only 150 foot-candles, I just kept my fingers crossed until I saw the results. It means big things for color film production in general."

Arcs Still to Be Used

Lest it be interpreted from the foregoing that arc lighting is doomed to oblivion, insofar as color photography is concerned, it should be stated here that in the opinion of most directors of photography the general scheme for set lighting will probably be as follows for the new Technicolor system:

A—Small sets: practically all unfiltered incandescents.

B—Medium sets: unfiltered incandescents with some filtered arcs.

65 amperes on the 8mm-7mm trim
45 amperes on the 7mm-6mm trim

The unit package and the 5-unit case will be conspicuously labeled with the word "Victory" and will indicate the reduction in current rating.

If a "Victory" carbon is paired with a heavier copper-coated carbon, it may be necessary to make a slight adjustment in the rate of the feed to compensate for the change in burning ratio, and the maximum current marked on the "Victory" carbon should not be exceeded.

The price of "Victory" carbons is the same as that of the heavier copper-coated carbons which they replace. It is to be emphasized that, as in World War II, the supply of projector carbons will be adequate.

C—Large sets: unfiltered incandescents with a larger percentage of filtered arcs than used on medium sets.

D—The use of arcs will vary with the cameraman as at present with black-and-white photography.

As to the general availability of the new Technicolor system, the corporation is said to be aiming for full conversion to the new process within four to six months. It can handle some small Hollywood production sequences immediately.

NPA Theater Equipment Group

A task group of six members has been appointed by National Production Authority (NPA) to study the problem of conservation of and substitution for critical materials used in the manufacture of motion picture equipment. The group, which is to report within 30 days, includes:

R. B. Tompkins, International Projector Corp., chairman; O. B. Rendahl, National Carbon; Fred C. Matthews, Motiograph; E. J. Vallen, Vallen, Inc.; Leonard Satz, Raytone Screen, and Jim Elderkin, Forest Mfg.

Another task group which will offer recommendations leading to possible controls covering 35-mm equipment similar to those used during World War II, should such a move become necessary, is comprised of:

Henry Fisher, DeVry Corp.; C. S. Ashcraft, Ashcraft Mfg.; W. D. Hausler, Century Projector; H. B. Engel, GoldE Mfg.; P. F. Thomas, Altec-Lansing, and R. H. Heacock RCA. This group will also report its findings within 30 days.



TELECASTS

TOA Stymied by FCC Inter-City Facility Deferment

ON THE same day (Jan. 10) that the Theater Owners of America called upon the FCC to give recognition to the need for the use of inter-city transmission facilities for theater video, the latter body announced the indefinite postponement of hearings on inter-city facilities which would have permitted A. T. & T. and the Tv networks to try out a recently reached agreement.

The FCC decision was a severe blow to the exhibitor body, which had entertained high hopes that an immediate start could be made on a solution to the serious problem of Tv network broadcasts inroads on theater admissions.

The exhibitor brief declared that prompt FCC action was necessary because "to do otherwise would be to deprive the public of programming which they have demonstrated a desire to have and would discriminate against the small user."

Basis of TOA Petition

TOA petitioned the FCC in August, 1949, for institution of a rule making proceedings looking toward the allocation of facilities for theater Tv service, declaring that "Theater Tv is a new medium (which has) potentialities of becoming one of the greatest and most important techniques" for accomplishing the declared objectives of the Federal Communications Act.

The FCC, the petitioner reminds, has always encouraged experimentation in new techniques for harnessing radio frequencies so their usage will redound to the benefit of the general public—citing frequency modulation and television—the latter in its early days "only a few years ago" when it was highly experimental, sporadic and geographically limited. The result, said TOA, was phenomenal growth of Tv.

Continuing: "Theater Tv has developed to the same point where Tv broadcasting was three or four years ago. Common carriers, by definition, cannot discriminate between the large or small or the frequent or sporadic user.

Cites Present Theater Tv

"Today there are about 15 theater Tv installations in about 10 key Metropolitan areas. The investment in this equipment is considerable, and many exhibitors are hesitant to commit themselves to the costs involved before they have some assurances that

programs are available and that the means for the transmission of programs will be available at reasonable cost.

"TOA believes that the ultimate solution to the quest for a nationwide theater Tv service lies in the allocation of special frequencies for this purpose. In the meantime and until the Commission holds the theater Tv hearings and issues a decision in that proceeding, those who desire to render such a service are completely dependent upon A. T. & T. facilities.

Network Aid Minimized

"The prospects of any of the networks relinquishing time to theater Tv is even dimmer now than before. The amount of time left for theater Tv experimentation during periods which are practical in terms of theater operations is rapidly diminishing," the FCC was told.

* * *

Theater Tv for 71 Coast Houses?

News from two responsible sources indicate that serious consideration is being given to installing theater Tv equipment in more than 70 theaters on the West Coast. First, Frank Folsom, president of RCA, stated flatly that "one large theater circuit is planning for installations of video equipment in 71 theaters from Yuma, Ariz., to San Francisco."

Folsom's obviously referred to Fox West Coast Theaters, the president of which, Charles Skouras, only a few days earlier had stated that installations of Tv units in "selected showcases" would begin within six months. Negotiations are in progress for the exclusive rights to athletic and public events for theater Tv, said Skouras.

* * *

First Theater Tv on West Coast

First theater Tv showing West of Chicago was staged at the Orpheum Theater, Los Angeles on Dec. 27 last, the program fare being a half-hour show emanating from the Palladium Ballroom in Hollywood which is a regular feature of Tv station KLAC, with which the theater tieup was made.

The program was interpolated into the Orpheum's usual screen show, utilizing RCA theater Tv equipment. The Tv projector was mounted at the rear of the stage, with the control panels installed in

the projection room, in accordance with the usual RCA procedure. The screen image was 15 x 20 feet.

Orpheum theater officials plan to stage periodic Tv showings over the RCA equipment, installed at a reported cost of \$40,000, in an effort to gauge public reaction over a somewhat lengthy period before proceeding with other installations on the same circuit.

* * *

National Ads on RCA Theater Tv

A new twist to the RCA campaign to promote more wider use of theater Tv was the appearance in national magazines of ads extolling the benefits to be derived by the general public from attendance at theater Tv showings. Caption for the illustration showing a theater audience viewing a prizefight is: "New RCA theater television system projects 15 x 20-foot pictures of television programs."

The text below is headed: "Giant Size Television"—"Shot From a Barrel!" Then the body copy: "You've seen television. Now you'll see it in its finest form—giant projections of special events, transmitted only to theaters on private wires or radio beams to make movie-going better than ever.

Technical Data Included

"Success of the system comes from a remarkable RCA kinescope, and something new in projection lenses. The kinescope . . . is in principle the same as the one on which you see regular telecasts. But it is small—only a few inches in diameter—and produces images of high brilliance. These are magnified to 15 x 20 feet by a 'Schmidt-type' lens system like those used in the finest astronomical telescopes.

"Because of its size and shape, the new projector is referred to by engineers as the 'barrel.' It's already going into theaters, where you'll be seeing giant television—shot from a barrel."

The ad emphasizes that Tv programs in theaters will be transmitted *only* via private wires and radio beams, *not* by pickup from a regular Tv broadcast.

* * *

Radio, Tv Materiels Cutback

The radio and television producing industry has been told by the National Production Board that a major problem to-

day is a shortage of certain basic materials. In order to assure adequate supplies of these materials to meet defense and related requirements, NPA stated that it has under consideration limitations on the non-military use of nickel, copper, and aluminum. Tentative plans call for cut-backs in the use of these materials up to possibly 20 or 30% below the average rate of use during an appropriate base period, which is to be determined.

NPA stressed that such a program will apply "across-the-board" to all users of the materials in their primary forms, but will in no way affect permitted consumption by product or end use. Each user affected will decide what types of products will be manufactured.

Fire Risk Due to TV Lenses

It is a well-known fact that the sun's rays, if concentrated through a magnifying lens and directed upon readily combustible material, can cause fire. An example of this has been quoted where the sun's rays, passing through a transparent plastic door handle, ignited a bath robe. Heath and forest fires have been attributed to the concentration of the sun's rays through broken glass and bottles and, today, a new medium has been introduced into daily life by means of which "insolation" (as it is called) can occur.

Radio dealers are displaying in their show windows new types of magnifying lenses for attachment to television sets. Already some incidents have occurred where insolation has set fire to the contents of radio dealers' windows where lenses are displayed.—*Fire Protection Association Journal*, July, 1950.

IA ELECTIONS

LOCAL 25, ROCHESTER, N. Y.

Charles Redes, *pres.*; M. Torrey, *vice-pres.*; William Hogan, *sec.*; Frank Higgins, *treas.*; Mike J. Mungovan, *bus. rep.*

LOCAL 96, WORCESTER, MASS.

John E. Murphy, *pres.*; William Sullivan, *vice-pres.*; Walter Quist, *rec. sec.*; S. Michael Haddad, *fin. sec.*; Harold Wyman, *treas.*; J. E. Murphy, *bus. rep.*; Philip Gruen, W. Sullivan, George Gravel, John Cummins, Thomas Cummins, Roger Kavanaugh, *exec. board*; Thomas McGualey, *sgt.-at-arms.*

LOCAL 105, LONDON, ONT.

S. Shaw, *pres.*; W. Hewitt, *vice-pres.*; C. Mills, *sec. treas.*; W. Shaw, *rec. sec.*; W. Drennan, *bus. rep. (projectionists)*; J. Garnet, *bus. rep. (stagehands)*; C. Mills, S. Bradford, S. Shaw, *exam. board*; W. Drennan, W. Hewitt, H. Allaster, *trustees*; W. Shaw, M. Rehder, *auditors*; C. Johnson, *sgt.-at-arms.*

LOCAL 150, LOS ANGELES, CALIF.

John Maynard, *pres.*; Frank McBryde, *vice-pres.*; Charles A. Vencill, *sec. treas.*; George J. Schaffer, *bus. rep.*; Harold Angel, Frank C. Champlin, Clem J. Marchand, C. C.



more
B.A.*

*(BOXOFFICE
APPEAL)

MOVIES
ARE
BETTER
THAN
EVER

with **SUPER SNAPLITE**

f/1.9 projection lenses

• GREATER LIGHT • GREATER CONTRAST • GREATER SHARPNESS

Watch your "B. A." climb when you install Super Snaplite Lenses. Give your patrons the benefit of pictures at their best. You can't beat the Super Snaplite f/1.9 when it comes to putting a clear, sharp picture on your screen.

Super Snaplites give you a true speed of f/1.9 in every focal length up to 7 inches. Ask for Bulletins 207 and 209.

"You Get More Light with Super Snaplite"



*(BOXOFFICE
APPEAL)

KOLLMORGEN
2 Franklin Avenue
Brooklyn 11, New York
Optical CORPORATION



Piper, H. C. Smith, *exec. board*; C. C. Bolinger, Virgil Crowell, E. J. (Red) Schmidt, *exam. board*; Duane Adams, Henry Kearney, Ray Richards, *trustees*; Tom Veith, *guide*; Tom Gillum, *sgt.-at-arms*.

LOCAL 154, SEATTLE, WASH.

Fred Jiencke, *pres.*; Harold Simpson, *vice-pres.*; Thomas Watters, *sec.*; Robert C. Cameron, *fin.-sec.*; James McNabb, *bus. rep.*

LOCAL 173, TORONTO, ONT.

James Sturgess, *pres.*; Arthur Milligan, *vice-pres.*; Pat Travers, *rec.-sec.*; George H. Jones, *sec.-treas.*; William P. Covert, *bus. rep.*; Norm Tanner, Jack Hills, Lou Lodge, R. O'Connor, *exec. board*; D. Cameron, J. Stronger, E. Whyatt, *trustees*.

LOCAL 175, TACOMA, WASH.

O. J. Carlson, *pres.*; J. R. Burke, *vice-*

pres.; Jack Shepherd, *rec.-sec.*; C. J. Kaelel, *fin.-sec. and bus. rep.*; J. L. Jarmon, Orin M. Jacobson, Carl Ellis, A. E. Bradshaw, B. F. Yost, *exec. board*; R. L. Kneeland, Carl Ellis, B. F. Yost, *trustees*; O. M. Dennis, *reading clerk*; R. L. Kneeland, *sgt.-at-arms*.

LOCAL 182, BOSTON, MASS.

Joseph Nuzzolo, *pres.*; Bernard J. Lynch, *vice-pres.*; James M. Gibbons, *rec.-sec.*; Leon A. Narbut, *fin.-sec.*; Joseph Caplan, *treas.*; Walter F. Diehl, *bus. rep.*; William Kaitz, Patrick J. Kelly, Alexander S. Tradd, Fred S. Jones, Henry Perry, *seniority board*; Harold Armistead, William Dwyer, Ralph Frazier, *exec. board*; Michael J. Driscoll, Benjamin Bearman, *trustees*.

LOCAL 219, MINNEAPOLIS, MINN.

S. S. Parrish, *pres.*; Frank Rogers, *vice-pres.*; Rudy Peterson, *sec.*; Joe Ellwood, *fin.-sec.*; Frank Schilken, Jr., *bus. rep.*; Wallace J. Yutz, A. W. Harris, L. G. Cowan, W. H. Smith, *exec. board*.

LOCAL 307, PHILADELPHIA, PENNA.

Harry J. Abbott, *pres.*; Abbott Oliver, *vice-pres.*; Joseph H. Abrams, *rec.-sec.*; Charles Humphries, *fin. sec.-treas.*; Horace B. Johns, *bus. rep.*; Frank J. Adams, Robert Bloch, Benjamin Green, Parker Kennedy, *exec. board*.

LOCAL 366, WESTCHESTER COUNTY, N. Y.

Nat Storch, *pres.*; James Maloney, *vice-*

pres.; Joseph Yans, *rec.-sec.*; Morris Steinberg, *fin.-sec.*; Joe Monaco, *bus. rep.*; Anthony Popp, Anthony Aquino, *trustees*.

LOCAL 401, CENTRALIA, WASH.

North D. Stark, *pres.*; Harry A. Kirkpatrick, *vice-pres.*; Rex Kinsey, *rec.-sec.*; Charles W. Wheeler, *sec.-treas.*; C. E. Staples, *bus. rep. Centralia-Chehalis*; Ross V. Kinsey, *bus. rep. Vancouver-Camas*; J. R. Spiker, *bus. rep. Longview-Kelso*; C. Staples, H. Kirkpatrick, J. J. Cunlisk, N. Stark, C. Wheeler, *exec. board*; R. V. Kinsey, *sgt.-at-arms*.

LOCAL 451, NEW CASTLE, PENN.

Norman Freeborne, *pres.*; Frank N. Eakin, *vice-pres.*; William J. McCormick, *sec.*; William F. Hall, *treas.*; John Brogan, *bus. rep.*; George Kalata, R. O. Woodring, Paul Walter, *trustees*.

LOCAL 521, LONG BEACH, CALIF.

Vernon (Mike) Martz, *pres.*; Marvel Fairchild, *vice-pres.*; Alonzo S. Bennett, *sec.-treas.*; Gilbert A. Lahlum, *bus. rep.*; Ward LaBar, LeRoy A. Ward, M. Fairchild; Ralph Addy, A. S. Bennett, V. G. Martz, Elliott Kirby, *exec. board*; Everett L. Covington, Claude E. Leyman, Jr.; Michael Petrich, *trustees*; Addy, Bennett, Roy Heckman, *exam. board*; Jack N. Ward, *sgt.-at-arms*.

LOCAL 586, COLUMBUS, HASTINGS, NORFOLK, and GRAND ISLAND, NEBR.

W. E. Snyder, *pres.*; F. L. Kerwood, *vice-pres.*; Conrad Krieger, *sec.*; E. O. Hart, *fin.-sec.*; L. Christofferson, *treas.*; Leo Tews,

Best Wishes
for a
Prosperous 1951
LOCAL NO. 449
Stamford, Conn.

You can see the difference . . .
Your Audiences can see the
difference!

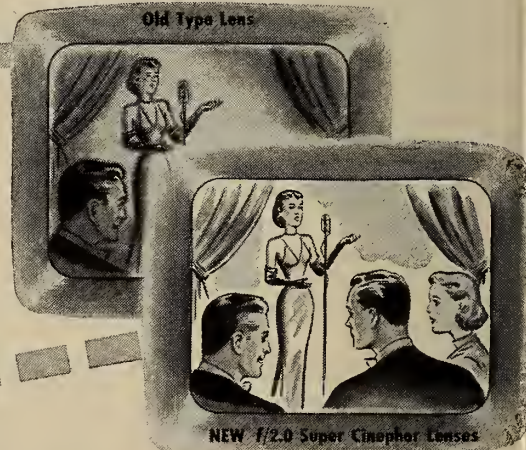
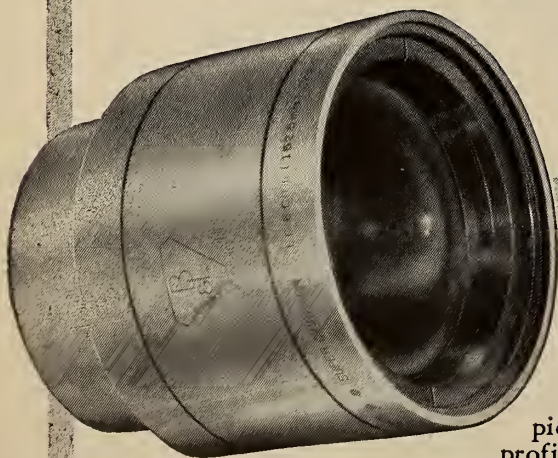

Replace NOW with new Bausch & Lomb f/2.0 Super Cinephor Lens

Brilliant illumination, 44% to 100% brighter . . . "edge-to-edge" contrast and sharpness . . . better vision at all ranges, all angles. Those are the advantages of equipping now with new Bausch & Lomb Super Cinephor Lenses. Show larger, brighter pictures to bigger audiences. Build steady patronage . . . steady, larger profits . . . with B&L quality images.

WRITE for complete information to Bausch & Lomb Optical Company, 616-1 St. Paul Street, Rochester 2, N. Y.

FOR TOP IMAGE QUALITY ON YOUR SCREEN . . . THE B&L TRADEMARK ON YOUR LENS



Bausch & Lomb *Super Cinephor* Projection Lenses

bus. rep.; R. O. Berger, *exec. board*; A. Brooke, F. Driskell, J. B. Smith, *trustees*; O. P. McCurdy, *sgt.-at-arms*.

LOCAL 771, NEW YORK, N. Y.
(MOTION PICTURE FILM EDITORS)

Fred Ahrens, *pres.*; Jack Bush, *vice-pres.*; Bob Dworsky, *sec.*; Larry Sherman, Jr., *treas.*; Charlie Wolfe, *bus. rep.*; Leonard Hein, Edward Wyant, Jr., John Oxton, Bob Klaeger, *trustees*; Fred Edwards, *sgt.-at-arms*.

NEWS PROJECTIONS

RATE of Tv set production, already curtailed to some extent by major manufacturers, may be trimmed to 50% by early Spring, according to the video trade. Also, price hikes for sets are inevitable, possibly by 25%, to balance recent and anticipated excise levy. Examples: Admiral has cut production by 10%, Olympia and Emerson by 20%, Andrea by 40%, and RCA by an undisclosed figure. . . . Mid-week closing of theaters, with operation only from Friday through Monday, are considered as likely by the TOA of New Jersey. Reason: dearth of top-flight pictures for week-long operation. . . . Zooming Govt. orders for raw film stock forecast a tight supply situation for the future. Newsreels have been using DuPont stock for some months now, following Eastman's total conversion to acetate (safety). Tv daily newsreels may have to discontinue if the shortage grows acute.

WPIX, New York Tv station owned by the *Daily News*, now has a staff of 11 editors and photographers, plus a complete laboratory, and is broadcasting 60 regularly-scheduled news periods a week, in addition to bulletins and special features. . . . Film leaders encouraged by Dept. of Justice favoring of a voluntary arbitration system within the framework of the anti-trust consent decrees now being negotiated. . . . Madison Square Garden, New York's nationally-known sports arena, is mulling banning televising of its events, citing falling box-office receipts. Garden management would like an outlet direct to large-screen theater Tv, with its accompanying fat receipts. . . . About three-quarters of those owning Tv sets are in the broad lower and middle income brackets, comprising the great bulk of movie-going families, according to a recent Wall St. survey. . . . M-G-M, evidently undeterred by the industry-wide Tv jitters, has 32 features scheduled to roll within the next six months. Ma-

Movies are better than ever! —but how good is the HEART of your theatre?

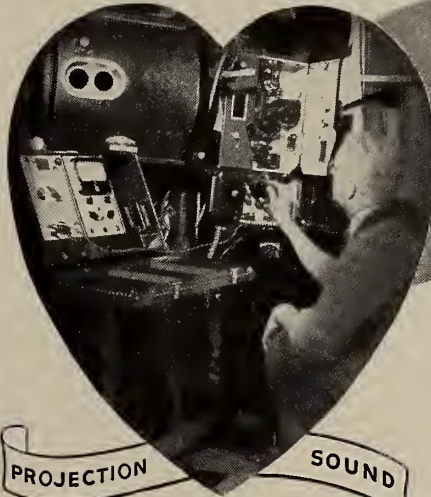

... AND RCA SERVICE

It costs so little to protect so much

The advantages of RCA Service are yours at a cost so low, a few admissions daily pay for it. Write for free folder—“Performance Security.”



It's good showmanship to make sure that your projection room equipment—the heart of your theatre—operates at peak form . . . at top efficiency. Even with the best-designed and best-made picture projection equipment and sound reproduction system, constant usage causes wear and tear. If not properly maintained, projection room equipment may cause trouble . . . run up costly repair bills . . . result in a “blackout” and loss of box-office receipts.

With RCA Service you can be sure the heart of your theatre is maintained in a thoroughly dependable condition. RCA Service technicians are skilled in the systematic point-to-point checkup and maintenance of all types of projection and sound equipment regardless of make. RCA Service Plans combine expert technical assistance with comprehensive parts and repair provisions for motion picture and theatre TV equipments.



RCA SERVICE COMPANY, INC.

A RADIO CORPORATION of AMERICA SUBSIDIARY
CAMDEN, NEW JERSEY

CLAYTON BALL-BEARING EVEN TENSION TAKE-UPS

For all projectors and sound equipments

All take-ups wind film on 2, 4 and 5 inch hub reels.

Silent Chain Drives

THE CLAYTON REWINDER

For perfect rewinding on 2000-foot reels.

CLAYTON PRODUCTS CO.

31-45 Tibbett Avenue

New York 63, N. Y.

majority of films will be in Technicolor. . . . Next major worry for the film exhibition field is possibility of a state tax on admissions, plus an increase in the present Federal tax.

BRUSH-UP ON FUNDAMENTALS

(Continued from page 19)

to make up for the loss in capacitance it would be necessary to increase the area of the plates, thereby making a very bulky condenser.

Mica condensers of this type have been used recently in some radar equipment. They were about ten times larger than ordinary "postage stamp" mica condensers and were capable of withstanding from 2500 to 5000 volts.

The amount of voltage that a condenser can safely withstand is clearly marked thereon. These voltage ratings vary for different kinds of condensers: for mica condensers the values range from 500 to 5000 volts; for paper condensers from 150 to 2500 volts, and for electrolytics from 25 to 600 volts.

Rating of Condensers

The size of a condenser is known as its "capacitance" and the unit of capacitance is the "farad," named so in honor of the English scientist, Michael Faraday. This unit is much too large for practical work. In practical work the micro-farad (one millionth of a farad) and the micro-microfarad also called the pica-farad (one-millionth of one-millionth farad) are used. The farad is the amount of capacitance present when one coulomb of energy is stored in a dielectric field under a pressure of one volt.

Paper and electrolytic condensers usually are rated in micro-farads; while mica condensers are rated in micro-microfarads. The electrical symbol for the micro-farad is μfd , and the symbol for micro-microfarad is $\mu\mu\text{fd}$. The Greek

letter μ (Mu) is used to represent the word micro.

Some manufacturers used the letter "m" in place of the Greek letter μ , so that micro-farad would be written "mfd," and the micro-microfarad would be written "mmfd." Sometimes the "d" in mfd or mmfd is omitted.

Electrolytic condensers usually are from 4 mfd up; paper condensers are from .001 mfd (1000 mmfd) to 5 mfd; and mica condensers run from 1 mmfd (.000001 mfd) up to 1000 mmfd (.001). The size is clearly stamped on paper and electrolytic condensers; and on mica condensers the size is sometimes stamped but more often it appears by means of a color code which has become standard for the industry.

The capacitance of a parallel plate condenser may be calculated by the following formula:

$$C = \frac{0.0885 \times K \times A \times (N-1)}{t}$$

Where C is the capacitance of the con-

EFFICIENT • DEPENDABLE

RECTIFIERS

for Every Type Projection Lamp



2-Tube
4-Tube
6-Tube
Single and
Three Phase
Models for

- Rotating Feed Angular Trim High Intensity
- Copper Coated Coaxial High Intensity

- 1 K.W. High Intensity
- Low Intensity

Smooth Output Current • Long Life
Low Operating Temperature
Flexibility in Control

Write today for literature or free demonstration.

**THE STRONG
ELECTRIC CORP.**

31 CITY PARK AVENUE
TOLEDO 2, OHIO

PROJECTION LAMPS • RECTIFIERS
SPOTLIGHTS • REFLECTORS



DON'T KILL THE MAN WITH THE FLUTE



A good sound system should be capable of reproducing the entire sound frequency range recorded on the film from the lowest 40 cycle tones of the bass viol to the 10,000 cycle tones of the flute.

MOTIOGRAPH SOUND SYSTEMS *Guarantee*

the best balanced, most complete tonal range; life-like reproduction; delicate shadings of voice; musical qualities never before approached; uniform sound level throughout the theatre.

14 models for indoor theatres from 500 to 5,000 seats and drive-ins from 200 to over 1,000 cars—ALL built to the one same high standard of quality.

For free literature address

M O T I O G R A P H , I N C .

"America's Oldest Manufacturer of Projection Equipment"
4431 WEST LAKE STREET CHICAGO 24, ILLINOIS



KLENZ
CLEANSES LENSES

REFLECTORS
MIRRORS

Clarifying Definition of
Picture and Sound

Price \$1.50

423
ESSANNAY ELECTRIC MFG. CO.
1438 North Clark Street
CHICAGO 10, ILLINOIS
3 Fluid Ounces

denser in micro-microfarads, K is the dielectric constant of the insulator between the plates, A is the area of one plate in square centimeters, N is the total number of plates, and t is the distance between the plates or thickness of the dielectric in centimeters.

Construction of Condensers

One of the most common of commercial condensers is the variable air type. This is the device you turn when you tune in a station on your radio receiver. The variable condenser consists of two sections of brass or aluminum plates, one set being free to turn and called the "rotor," and the other set being fixed and called the "stator." When the rotor is turned, the effective area of the condenser plates is changed, and this varies the capacitance. For this reason the condenser is known as a "variable" condenser.

Condensers, the capacitance of which cannot be varied at will are known as fixed condensers. A mica condenser falls under this type. This condenser consists of several plates of steel, brass, tin foil, or aluminum, each set of plates being separated by a sheet of India mica. Each alternate set of plates is connected together and two leads are brought out from the condenser. The metal and mica combination is then molded in bakelite

TABLE OF DIELECTRIC CONSTANTS

The following is a table of approximate dielectric constants for some materials that are commonly used as insulators in condensers.

Celluloid, photographic film.	6.7
Cellulose nitrate	3.8
Fiber	4.8
Fused quartz	4.0
Glass	6.5
Pyrex	4.9
Hard rubber	3.0
Isolantite	6.1
Mica, India	6.0 to 8.69
Paper	2.6
Polystyrene	2.6
Porcelain	7.0
Wood	2.5 to 6.8

or some other type of moisture-proof binder.

Some mica condensers are variable and are known as trimmers or padders. These condensers are not enclosed in a molded binder, and have instead a little set screw running through the plates, but insulated from them. Changing the setting of the screw brings the plates closer, or further apart, thereby changing the capacitance.

Trimmers vary in size from 5 to 50 mmfd, and padders run up to around 250 mmfd. Paper condensers consist of two plates of tin foil separated by waxed pa-

per. In order to obtain a great deal of capacitance in a small space, the tinfoil and paper are rolled up and the resulting condenser is incased in a jacket of cardboard. Two leads are brought out—one from each plate. The ends of the con-

denser are covered with sealing wax to keep out dirt and moisture.

The paper dielectric is usually made up from several separate sheets of very thin waxed paper instead of just one sheet of proper thickness. This type of



This is the **CARBON SAVER**
Everyone Is Talking About!

**THE CRON-O-MATIC
FULLY AUTOMATIC
CARBON SAVER**

It's the big talk because here at last is a carbon saver THAT REALLY WORKS! It uses up carbons of all sizes with no preparation of the stubs being required. You simply insert the stub in the holder and forget it. It in no way interferes with the regular operation of the lamp. Take advantage of this new and easy way to save real money. Install a Cron-O-Matic and CUT YOUR CARBON COSTS 25%.

PAYNE PRODUCTS COMPANY
Cron-O-Matic Division
2454 W. Stadium Blvd. Ann Arbor, Michigan

() Please send free literature on Cron-O-Matic Carbon Saver.
() Please ship Cron-O-Matic Carbon Saver
() C.O.D. including postage, () Remittance herewith,
() Send name of nearest dealer.

NAME
THEATRE
STREET
CITY & STATE

Dealer Inquiries Invited

Adaptable to Ashcraft "D", Brenkert-Enarc, Peerless Magnarc and Strong Mogul lamps.

Only \$52.50 and pays for itself in a short time . . . then goes on to make money for you in the future.

Sold by most leading theatre equipment dealers. If your dealer cannot supply you order from,

"World's Most Powerful Spotlight"

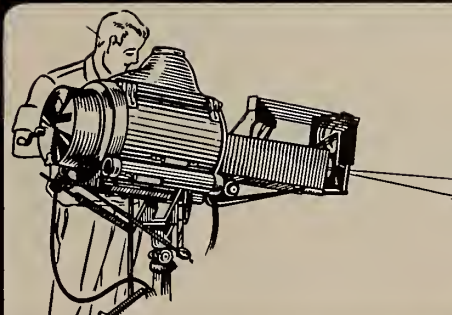

The METRO-LITE high-intensity carbon arc spotlight comes in two models:—

- ★ MODEL ME 4 125 Amps D.C. 100 ft. to 400 ft. throw.
- ★ MODEL ME 5 "Vaudeville" 60 to 85 Amps D.C. 75 ft. to 250 ft. throw.

METRO-LITE

Literature available on both units upon request to
GENARCO, Inc. 36-56 b 34th St., Long Island City 6, N. Y.

LOCAL UNION NO. 343, I. A. T. S. E.

OMAHA, NEBRASKA

wishes all Locals in the Alliance

A Happy and Prosperous 1951

construction minimizes the chances for voltage breakdown.

There are two types of electrolytic condensers—wet and dry. One plate of loosely rolled aluminum which is im-

mersed in an electrolytic solution, such as borax, is found in the wet electrolytic condenser. After a few seconds use, a thin film of aluminum oxide, and insulator, forms on the aluminum plate and acts as the dielectric. The container, which is usually made of zinc and forms a housing for the solution, forms the other plate. The aluminum is carefully insulated from the container by a strip of celluloid.

This condenser must be mounted in an upright position because of the danger of spilling the solution. Electrolytic condensers have polarity, the aluminum plate being positive, the zinc container being negative.

Proper Connection Vital

The condenser will be ruined if it is not connected in accordance with the polarity which is clearly marked or color-coded. Wet condensers can stand up under severe overloads and are self-healing after a temporary breakdown. The dry electrolytic condenser contains an electrolyte in the form of a paste and may be mounted in any position because it can not spill. Dry electrolytics are not self-healing and must be discarded after a breakdown.

The electrolytic condenser is widely used on direct or pulsating direct currents because it contains a large amount of capacitance in a very small space. The reason for this is because the dielectric film is very thin, only a few thousandths of an inch. Dry electrolytics are usually made up in multiple sections containing as many as five condensers in one container. The negative terminal usually is common for all sections.

'MYSTERIOUS' AERIAL IMAGE

(Continued from page 15)

tends a much smaller angle as viewed from the lens.

The truth of the matter is that these rays are a draftsman's fabrication—they do not exist in any motion picture projector! And because these rays have no real existence, the corresponding rays between the lens and the screen (drawn with heavy lines) also do not exist.

Figure 3 is an "optical booby-trap," designed to snare the unwary. No less a personage than Century's Mr. Davee has been caught in this trap: Fig. 4 of his contribution* is based upon the same erroneous reasoning. The error in his diagram is not self-evident, however, because, to add still another mistake, the aperture was placed closer to the arc-lamp mirror than to the projection lens. The result achieved was total destruction of the angular relationships involved.

With one foot in this booby-trap, Mr. Davee places his other foot in a treacherous bog. He declares: "The light which forms the mirror image . . . is scattered and utterly lost to the motion picture screen." Being justifiably proud of the

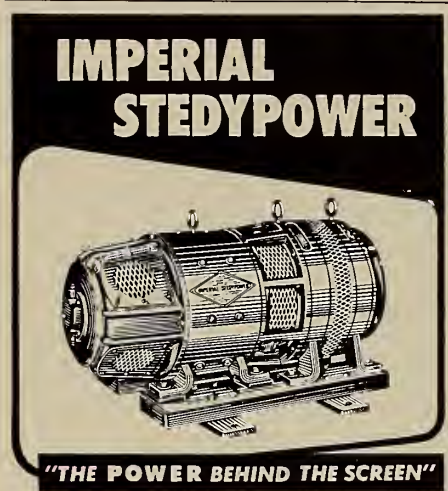

SPECIAL MOTOR GENERATORS FOR EVERY ARC PROJECTION

- Proven "Trouble Free" Performance
- Quality Built, Quiet Operation
- "Rubber in Shear" Mounted Vibration Free
- Long Life, Low Maintenance

Distributed by Independent Theatre Supply Dealers or Write to:



ONLY
Century **PROJECTORS**
HAVE EVERYTHING

- 4-inch diam. lens mount
- Water-cooled apertures
- Oil-less Bearings

CENTURY'S high-efficiency projector with the NEW 4-inch diam. lens, provides pictures of increased brightness and appeal—for even the largest drive-in screens.

CENTURY'S water-cooled aperture gives as much light with a 90 ampere arc as other projectors using a 180 ampere arc and heat filters!—Reduce power cost—Get sharper pictures—Save film.

CENTURY'S sealed, oil-less bearings and glass-hard gears reduce maintenance costs. No oil sprays or baths to mess up film or projection room.

You can SEE and HEAR the difference!

CENTURY PROJECTION AND SOUND SYSTEMS
See your dealer or write for information

CENTURY PROJECTOR CORPORATION
New York, N. Y.

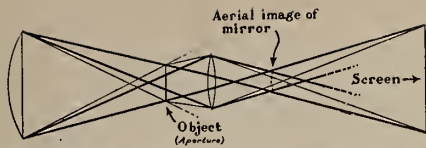

FIG. 4. The twofold optical function of the motion picture projector. Images of both the photograph on the film and the lamphouse mirror are formed simultaneously, but in different focal planes.

quality of their lenses, optical manufacturers may find this challenging statement sufficient cause for considerable eyebrow-lifting.

The foregoing discussion has demonstrated, as well as words and diagrams can tell the story, that the aerial mirror image is the orifice through which all light must pass on its way to the screen, where it forms a second image—the image of the film in the aperture. Discounting the effects of dust and scratches on the lens, no light is ever scattered and utterly lost to the screen!

It may be thought that the silver grains in the film emulsion effectively scatter light, thus creating rays which follow the course of the rays shown in Fig. 1. This scattering, due to both diffraction and multiple reflections, does exist; but tests indicate conclusively that the amount of light thus scattered is very much less than 0.1% of the total light flux—far too little to be visible on the screen. In fact, oil, dirt, and scratches on the film are the principle cause of this scattered light in many cases.

Technicolor prints are interesting in this connection, since the dye images are perfectly transparent, as far as freedom from diffraction effects is concerned, throughout the entire density range. Technicolor films, it may be said, scatter no light at all.

For all practical purposes, therefore, we write off scattering of light by the film as non-existent. The film can be considered as a true transparency, absorbing radiation in certain areas, but

CARE Aid Urged for Korea

Contributions in any amount sent to CARE for Korea, 20 Broad St., New York 5, N. Y., or any local CARE office in this country, will be used by the non-profit agency to deliver gift packages, in the name of the donors, to destitute Korean families chosen on the basis of greatest need.

Six types of CARE packages are available: Food, underwear and socks, or woolen suiting, at \$10 each; knitting wool, \$13; woolen blanket and cotton fabrics, \$7 each. Contributions less than the cost of a complete package will be pooled. All donors will receive a CARE receipt.

The CARE campaign was undertaken at the request of the Advisory Committee on Voluntary Foreign Aid of the U.S. Dept. of State and has been endorsed by President Truman.

allowing more or less light to pass through other areas of the picture with unchanged direction.

A correct diagram of the light rays in motion picture projection must take into account the formation of both mirror and film images. The diagram, to be absolutely correct, must also show that all the rays which reach the screen first form the aerial mirror image—they cannot by-pass the aerial image. Also, no rays can be drawn which do not originate from some point of the mirror.

Mirror is Controlling Factor

Figure 4 is such a diagram, careful examination of which reveals that all conditions have been fulfilled and repre-

sented faithfully. Every ray picked up by the lens and projected to the screen through the aerial image can be traced back to the mirror, the sole source of illumination.

The aerial image, itself, possesses little practical importance for the projectionist in these days of rear shutters. In the old days, when front-shutter mechanisms were the rule, the aerial image was a factor to be reckoned with. By positioning the shutter in the plane of the aerial image (from 2 to 4 inches in front of the lens tube) the cutoff of the light-beam occurs at its narrowest point, hence is the most rapid cutoff possible with a front shutter. With the shutter working in the aerial image, it was

NEVER HAS

Economy

BEEN SO

ESSENTIAL AS NOW!

SLOW BURNING

SAVINGS IN POWER CONSUMPTION

SAVINGS IN MAINTENANCE

ECONOMIZE

WITH *Lorraine*

Carbons

Lorraine CARBONS, INC., BOONTON, N. J.

THERE IS A LORRAINE CARBON TAILORED FOR YOUR SPECIFIC PROJECTION REQUIREMENT

Send necessary projection equipment data to guide us in recommending the Lorraine Carbons that will do your theatre or drive-in projection job better and More Economically.

A central location in

NEW YORK

City

Subway and Bus at Door, convenient to theatres, shopping, and all places of interest. A modern eight-story fireproof hotel... delightfully comfortable guest rooms... all hotel facilities. Moderate Rates.

from . . . \$2.50, Single
 from . . . \$3.50, Double
 from . . \$5.00, Two-Room Suites with Private Bath

MARIE ANTOINETTE HOTEL
 Broadway at 66th St.

Milton A. King, Manager



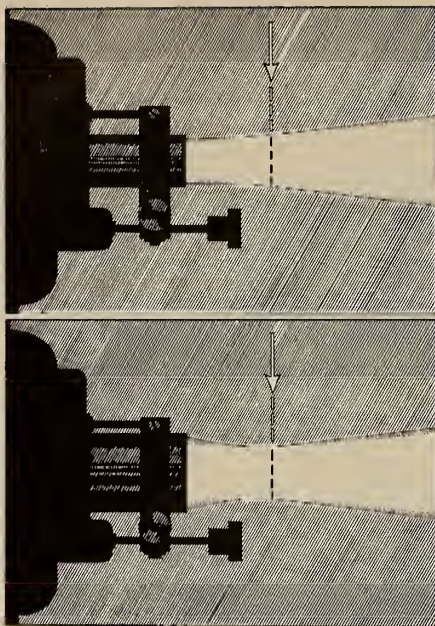

FIG. 5. The form of the light-beam when lenses of different diameters, but having the same focal length, are used. If the lens has a diameter greater than that of the aerial image, an "hourglass" constriction of the beam is produced.

possible to trim the shutter blades to their minimum width, enabling even more light to reach the screen than is possible with a single-disc rear shutter—another type of shutter now obsolete.

If the front shutter were moved out of the aerial-image plane, either toward the screen or toward the lens, travel-ghost would appear, necessitating a widening of the shutter blades in order to improve the quality of the picture. The importance of the aerial image in the positioning of front shutters is often overlooked—even by "experts."

Lens Diameter Influence

In many cases, the position of the aerial image in the light-beam is indicated by an hourglass-form of the beam. The aerial image exists in the constriction of the hourglass. In other cases, however, no such constriction can be seen—the light appears to travel out straight for a few inches, and then spread out into the familiar cone-shaped beam. Fig. 5 illustrates both cases. It is assumed in this drawing that the same lamp is used with both machines, and that the two lenses have the same focal length. The only difference is the diameter of the lenses.

The machine in the top panel of Fig. 5 utilizes a small-diameter lens. If the diameter of the lens is no greater than the diameter of the aerial image (indicated by the dotted line), no hourglass form will exist.

The lower panel shows an identical machine using a "faster" lens. Since the diameter of this lens exceeds that of the aerial image, an hourglass is dis-

tinctly seen. The aerial image here has the same diameter as that in the top panel.

Locating the Aerial Image

The aerial image may be located with great accuracy by placing a dark card square to the lens, and then moving it away from the machine, holding it in the light beam all the time. At a certain point a clear reduced image of the lamp-house mirror will be formed. The card is then in the plane of the aerial image.

Here is still another method for locating the aerial image. If the light beam is gradually intercepted and finally cut off entirely by a card moved down into the beam, the light on the screen will, of course, gradually fade out into total darkness.

Now, if the card is moved down into the beam *between the lens and the aerial image*, the light will not fade out on the screen uniformly but will be shadowed first at the bottom of the screen, the blurry shadow moving *up*. If the card is moved down into the beam *on the far side of the aerial image*, the blurry shadow will move *down* on the screen. Only when the card intercepts the beam in the exact plane of the aerial image will the light fade uniformly all over the screen's surface, the shadow moving neither up nor down.

This method of finding the aerial image may remind the reader of the so-called "flicker test" sometimes used for focusing soundhead optical tubes. The principle involved is exactly the same.



YOU CAN "RELY" ON NATIONAL

How Many?

Was this copy dog-eared when it came to you? How many men read it ahead of you?

You would receive a clean, fresh copy *if you had a personal subscription—and you wouldn't have to wait—you would be first to read it.*

Use coupon below.

INTERNATIONAL PROJECTIONIST.

19 West 44 St., New York 18, N. Y.

Enter my subscription for 1 year—12 issues—\$2.50
 2 years—24 issues—\$4.00

Foreign and Canada: Add 50c per year.

Name

Address

City State

"The bonds I bought for our country's defense
-will see my twins through college!"



**HOW U. S. SAVINGS BONDS ARE PAYING OFF FOR
MRS. MARY CALLON OF INDIANAPOLIS, INDIANA**

"Meet Janet and Jack, my *twin* reasons for buying bonds," says Mary Callon. "Even though I'm a widow, these children are going to have a college education. The U. S. Savings Bonds I bought will see them through!"

Mrs. Callon's story can be your story, too!



"Back in 1942 I joined the Payroll Savings Plan at the U. S. Naval Ordnance Plant where I work as an executive secretary. I put 10% of my salary into bonds to help win the war. And I still buy bonds."



"Through careful managing, the twins and I have lived comfortably and saved too. This fall the twins will enter Butler University—thanks to U. S. Savings Bonds, the best way to save I know!"

What Mary Callon did, you can do, too—and just as easily! Just take these three simple steps—today:

1. *Make one big decision—to put saving first, before you even touch your income.*
2. *Decide to save a regular amount systematically, week after week, or month after month.*
3. *Start saving automatically by signing up today in the Payroll Savings Plan where you work or the Bond-A-*

Month Plan where you bank. You may save as little as \$1.25 a week or as much as \$375 a month. If you can set aside just \$7.50 weekly, in 10 years you'll have bonds and interest worth \$4,329.02 cash!

You'll be providing security not only for yourself and your family but for the free way of life that's so important to us all. And in far less time than you think, your plans will turn into reality, just as Mary Callon's are doing.

**FOR YOUR SECURITY, AND YOUR
COUNTRY'S TOO, SAVE NOW—THROUGH
REGULAR PURCHASE OF U. S. SAVINGS BONDS!**

Your government does not pay for this advertisement. It is donated as a public service by The Advertising Council and the Magazine Publishers of America through the co-operation of Foote, Cone & Belding and this publication.



*Makes
Good
Listening*

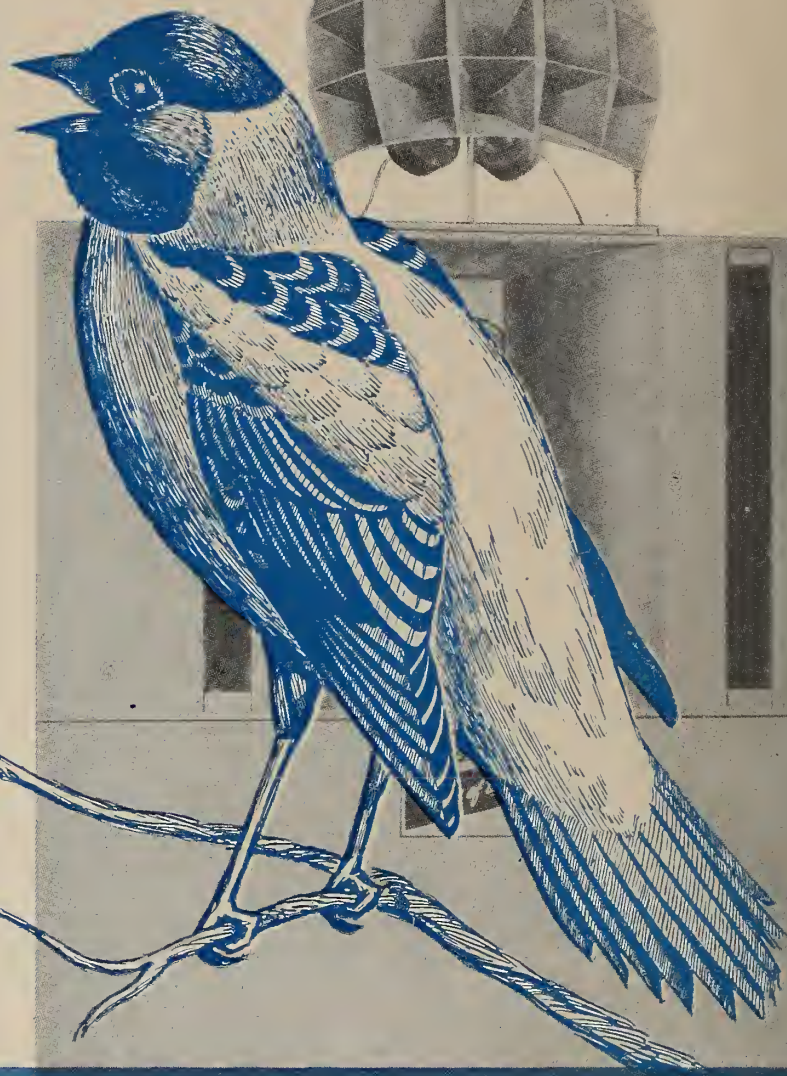

Simplex
REG. U.S. PAT. OFF.

X • L

SOUND SYSTEMS

MANUFACTURED BY INTERNATIONAL PROJECTOR CORPORATION • DISTRIBUTED BY NATIONAL THEATRE SUPPLY

07-24 289579

PROJECTIONIST

**I
N
T
E
R
N
A
T
I
O
N
A
L**



THE LIBRARY OF
CONGRESS
SERIAL RECORD

MAR 13 1951

FEBRUARY

1951

VOLUME 26



NUMBER 2

30c A COPY • \$2.50 A YEAR

7 out of 10
choose

Peerless
MAGNARC
TRADE MARK REG.

1-KW TO 70 AMPS

"HY-AX" ARC MAGNET

"HY-LUMEN" REFLECTOR

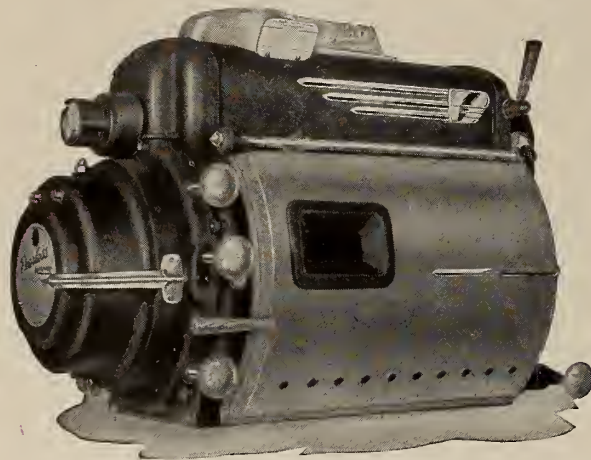

More light at 40 to 70 amperes than ever thought possible. . . . Equals and excels any reflector lamp to 85 amperes, whether they be unapproved water-cooled or resurrected "Hi-Lows". . . . Highest ratio of honest screen lumens per arc watt At 70 amperes, using an accurated Glass Hy-Lumen Reflector*, with a projector having an efficient revolving shutter, it develops the maximum screen brilliance that can be used without a heat filter at no risk of film damage. . . . Operating costs under these conditions are far below that of 85-ampere lamps.

Magnarc Lamps assure 80% side-to-center (SMPE Standard) screen light distribution, not a deceptive 60% or "Hot Center." . . . They are all Und. Lab., Inc. listed. . . . They are not insurance hazards. . . . They are and have been for years "The First Choice" of large and small theatres, drive-ins, and the motion picture industry.

*Similar results are not guaranteed if all-metal reflectors are used.

"FIRST WITH THE FINEST"

120-180 AMPERES

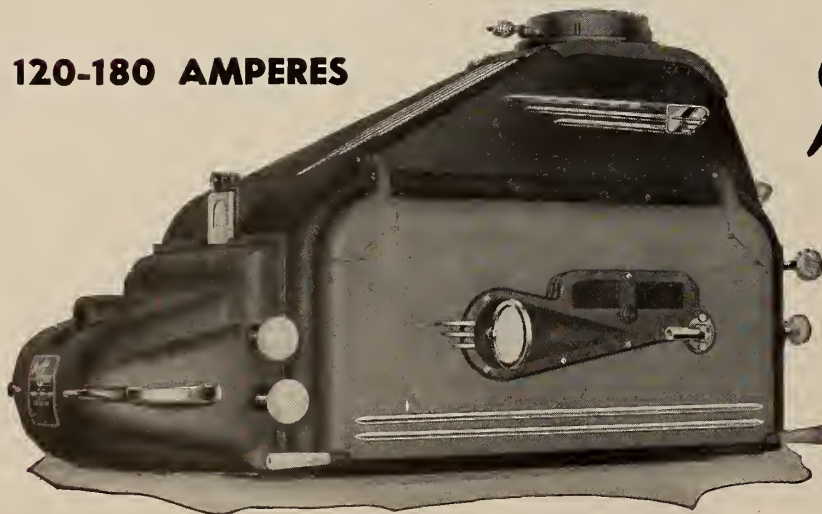

Peerless
HY-CADESCENT
TRADE MARK REG.

NEW MAGNETIC STABILIZER

This modern lamp produces all the light there is. . . . It is the standard equipment of the nation's largest and finest theatres. . . . Used by 90% of the largest Drive-In Theatres.

It is the "Omega" for maximum screen brilliance Nothing can even approach it in white light volume when used with projectors that have efficient revolving shutters.

Assures satisfying projection for Drive-Ins regardless of the size of the picture, length of throw, and under all weather conditions. . . . They are Und. Lab., Inc. listed and, therefore, not insurance hazards. . . . Heat filter assures no risk of film-heat damage at maximum arc amperage and maximum screen lumens.

"WHY EXPERIMENT?"



J.E. McAULEY MFG. CO.

552-554 WEST ADAMS STREET
CHICAGO 6, ILLINOIS

INTERNATIONAL PROJECTIONIST

With Which Is Combined PROJECTION ENGINEERING



HENRY B. SELLWOOD, *Editor*

Volume 26

FEBRUARY, 1951

Number 2

Index and Monthly Chat	3	The Cathode-Ray Tube: Basic Data, II	18
Optics of the Projection Arclamp	5	JOHN F. RIDER AND SEYMOUR D. USLAN	
ROBERT A. MITCHELL		In the Spotlight	20
Theater Television via the RCA PT-100 Equipment, III	8	HARRY SHERMAN	
RCA SERVICE COMPANY		Report on IA-IP, Amateur Radio Contest	21
Projectionist Examination Questions	10	AMOS KANAGA	
Motion Picture and Television Screens	13	First Month's Phonevision Chicago Test	22
FRANCIS BERGER		News Projections	23
Maintenance and Servicing of Motors, IV	16	IA Elections	24
ROBERT A. MITCHELL		News Notes	
		Technical Hints	
		Miscellaneous Items	

Published Monthly by

INTERNATIONAL PROJECTIONIST PUBLISHING CO., INC.

19 West 44 Street, New York 18, N. Y.

Telephone: MURRAY HILL 2-2948

R. A. ENTRACHT, Publisher

SUBSCRIPTION REPRESENTATIVES

AUSTRALIA: McGills, 183 Elizabeth St., Melbourne

NEW ZEALAND: Te Aro Book Depot, Ltd., 64 Courtenay Place, Wellington

ENGLAND and DOMINIONS: Wm. Dawson & Sons, Ltd., Macklin St., London, W. C. 2

YEARLY SUBSCRIPTION: United States and possessions, \$2.50 (two years, \$4); Canada and foreign countries, \$3; single copies, 30 cents. Changes of address should be submitted two weeks in advance of publication date to insure receipt of current issue. Entered as second class matter February 8, 1932, at the Post Office at New York, N. Y., under the act of March 3, 1879. Entire contents copyrighted 1951 by International Projectionist Publishing Co., Inc. INTERNATIONAL PROJECTIONIST is not responsible for personal opinions appearing in signed articles in its columns.



MONTHLY CHAT

GOOD news for projectionists, and for laboratory and exchange workers as well, issued from Eastman Kodak Company recently in the form of a notification that the problem of proper identification of nitrate and safety film, the topic of numerous complaints from the field, has been given long and serious thought and that a new system of identification has been adopted. These data have not yet been released by Eastman, thus a detailed report thereon will have to await an official nod from Rochester.

It was generally agreed in advance that the gradual replacement of nitrate prints with safety stock would prove more than a bit troublesome, and to this end Eastman spared no effort or expense (ably abetted by IP, if we must say so) to get precise operating instructions into the hands of thousands of projectionists. Of paramount importance, of course, was a means for quick identification of both types of prints.

A safe and simple method for identifying prints is not as easy as it might seem. Edge-marking of prints with the words "NITRATE FILM" and "SAFETY FILM" was adequate so long as only nitrate film was used for professional 35-mm theater films. The rub developed when both types of prints were circulating side by side, caused mainly by printing through from a safety negative onto a nitrate print, or *vice versa*. It soon became obvious that the existing system of identification just wouldn't do; and jittery projectionists were always fearful that a given print handled in approved fashion would come apart at the seams while in transit through the projector.

Many observers wondered why the exclusive use by projectionists of "all-purpose" film cement would not banish the bugaboo of splices coming apart, and they proceeded to demonstrate *in the laboratory* how simple the splicing process was. So far, so good; but we know that this "simple" lab process just didn't do the trick in the field. It could be that the manufacturers of all-purpose cements, badgered by mounting complaints, started to experiment with their formulas and thus further complicated matters.

Whatever the reason for the existing state of affairs, it would seem that Eastman has finally evolved a method which will go far to end the many difficulties experienced thus far in handling both types of stock. Once projectionists are reassured as to the proper identification of a given print—as seems likely under the proposed plan—they can banish their jitters and proceed in normal fashion. Maybe the makers of film cement will also find the going easier.

Eastman is to be congratulated for meeting a difficult problem head-on, without quibbling or evasion. Full details herein when they are available.

They're Made
for
Each Other!

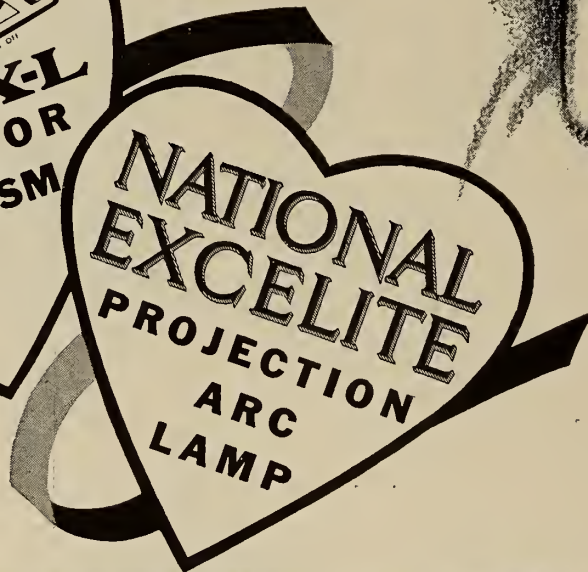

For super-brilliant pictures on large screens AT LOWER OPERATING COST, you'll buy this 75 to 130 ampere high intensity reflector type lamp.

- ♥ Air-cooled rotating positive carbon feeding mechanism.
- ♥ 16½" reflector.
- ♥ Automatic arc crater positioning.
- ♥ Stable burning and complete combustion at the arc, to avoid any black soot, are attained by a jet of air directed just above the arc.
- ♥ White smoke, which would otherwise cloud the mirror, is also diverted by this air stream.
- ♥ Unit construction permits instant removal of components for cleaning.

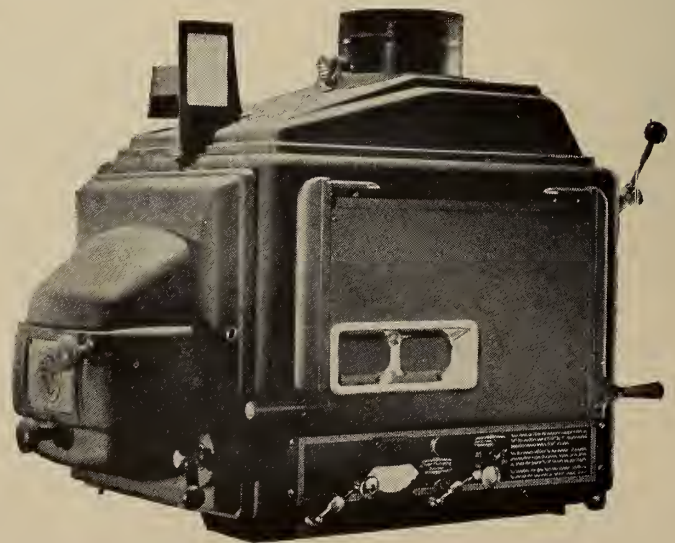

Distributed by



"THERE'S A BRANCH NEAR YOU"



Optics of the Projection Arclamp

By ROBERT A. MITCHELL

NOTEWORTHY advances have been made in projection lighting in recent years. First there was the Beck "high-intensity" arc. Higher powered lamps have been developed for motion picture applications; and improved burner construction has resulted in rotating-positive mirror lamps which make earlier attempts—notably the old "Hi-Lo"—seem very crude, indeed.

Very important, also, has been the successful production of automatic focus controls which make possible unprecedented accuracy in the positioning of the positive crater without the continued intervention of the projectionist.

There is, however, a dark side to this bright and shining cloud. The fall-off in screen-illumination uniformity which marked the transition from L-I to H-I projection about two decades ago remains a serious defect in projection quality.

The arclamp mirrors which are standard equipment at the present time are elliptical mirrors designed and applied according to a definite theory which has held sway ever since the inception of reflector lamps for projection lighting. This sacrosanct (?) theory demands that:

Standard Reflector Practice

1. The geometric focus (crater-mirror distance) and the working distance (mirror-aperture distance) shall be such that the image of the crater at the aperture shall be only a little larger than the aperture opening.
2. A reasonably true optical image of the crater shall be reflected onto the aperture by making the mirror a con-

cave ellipsoid with the crater at one "focus" and the center of the aperture opening at the other "focus."

Figure 1 shows what all this means. The cross-section of the mirror is a curve which, when continued, forms a closed oval figure called an *ellipse*. The imaginary ellipse is marked out on the drawing by the heavy curved line.

The Points of Foci

Now, every ellipse has inside it two definite points called *foci*. The sum of the distances from the two foci to any point on the ellipse is always the same—this is the unique property of the ellipse.

Condition (2) aforementioned is fulfilled by having the positive crater at one focus and the aperture at the other, as stated. This is shown in Fig. 1. Condition (1) is fulfilled by taking into

consideration the diameter of the positive crater and selecting the proper relation between the geometric focus and the working distance.

When reflector arcs were first made, this simple optical theory worked like a charm. By having a nearly perfect image of the crater mirrored onto the aperture, the shortest possible geometric focus could be used, thus increasing the "solid angle" of light picked up by the mirror.

Of course, the image of the crater on the aperture—the "spot"—was never really *perfect*, as small unavoidable humps and hollows in the mirror scattered the light to a certain extent. This was a good thing from the standpoint of uniform screen illumination, however.

Mechanics of L-I Operation

The L-I mirror lamp worked so well because the soft core of the positive carbon caused the middle of the crater to be somewhat less luminous than the outer zones. The inevitable tiny humps

FIGURE 1.
The curved surface of an elliptical mirror is produced in theory by rotating an ellipse around its major axis. Ordinarily, the crater of the positive carbon is placed at one focus of the ellipse, and the projector aperture at the other.

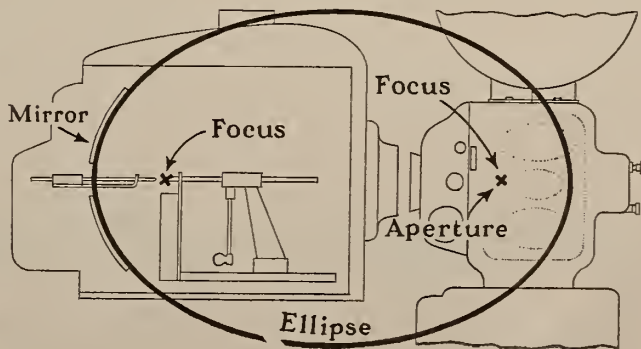

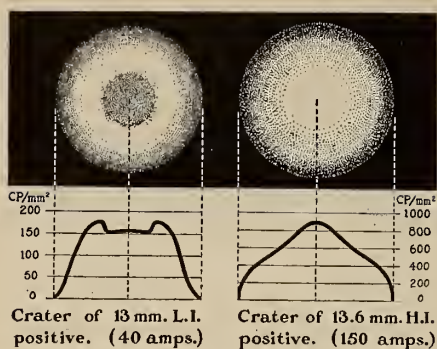

FIG. 2. Brilliancy distribution in low- and high-intensity arc craters.

and hollows in the mirror smoothed the light out to give the effect of a crater of perfectly uniform brilliancy all over its surface. Moreover, if in certain cases the spot was actually a trifle brighter at its edges than in its center, the "vignetting effect" of the early small-diameter projection lenses was effectively neutralized. Low-intensity lighting was admittedly yellowish and dim, but it at least illuminated the picture uniformly.

Figure 2 shows the appearance of the positive crater of both a 13-mm L-I carbon burning at 40 amps. and a 13.6-mm H-I carbon burning at about 150 amps. The graphs underneath the drawings indicate the actual luminosity of the various regions of these craters in candlepower per square millimeter.

Note that the H-I crater has "hot-spot" luminosity characteristics—the center is much brighter than the edge zones. *These characteristics are responsible for all our light-distribution difficulties with the H-I arc!*

Naturally, we have no way to make the H-I crater uniformly brilliant. The ball of luminous vapor is, by the nature of things, brightest at its greatest thickness—the central region of the ball. To do away with this luminous ball would be to destroy the H-I effect. The L-I crater had no such ball of brilliant gas, but depended only on the incandescence of white-hot carbon for its comparatively feeble light.

Mirror Characteristics Control

Obviously, any changes aimed at improving the light-distribution characteristics of the H-I lamp must be made in the mirror.

As an experiment, we may try out mirrors of different curvatures in a high-intensity lamp to see what improvement, if any, can be effected in the uniformity of screen illumination. We shall select mirrors having approximately the same overall focal length in order to keep the working distance constant.

The so-called "spherical" mirror is a good one to begin with. If it fails to improve screen illumination, it at least may

indicate the failings of the orthodox elliptical mirrors.

A spherical mirror is, as its name implies, the concave section of a perfect sphere. By using such a mirror, the ellipse shown in Fig. 1 becomes a circle. Now, a circle has only one "focus," and this coincides with the center of the circle. Naturally, the arc and aperture cannot be placed together at the same point, so a compromise is made by having the center of the circle between the crater and the aperture, leaving the working distance practically unaltered.

The results are manifestly disappointing. The sharpest "spot" we are able to obtain at the aperture looks like *A* in Fig. 3; and the resulting screen illumination, illustrated in the right-hand panel, has such a pronounced fadeaway that the sides and corners of the picture are barely discernible. This is "hot-spot projection" at its worst! And all of the light which does not pass through the aperture, but which splays out over the cooling plate, is utterly wasted, and serves only to make the projector mechanism uncomfortably hot.

'Why' of Spherical Aberration

What is the matter with the spherical type of mirror? All projectionists know the answer—an optical defect known as *spherical aberration*. This aberration stretches the crater image out along the optical axis in highly distorted form. Accordingly, no definite focal plane exists with this type of mirror, and the formation of a definite spot is impossible.

The specific reason for this unhappy state of affairs is that the outer zones of the mirror "curve in" too much, forming an image of the crater behind the aperture; while the central zones do not have enough curvature, and thus form an image somewhat beyond the aperture. The resultant poor light distribution and wasteful splaying of light all over the back of the mechanism cannot be avoided with this unsatisfactory type of mirror unless a Schmidt lens is used in conjunction with it—something we had rather not bother with.

Spherical mirrors are never used in projection except in Mazda lamphouses. They serve in this application because the filament of the bulb and the superposed image of the filament both lie in the single focal plane of the spherical mirror.

The Elliptical Mirror

B in Fig. 3 illustrates the type of spot and quality of screen illumination obtained with the orthodox elliptical mirror adjusted for maximum efficiency. The spot is larger than would seem absolutely necessary, but this is because only the brighter central areas of the crater

image are utilized for illuminating the picture.

If the spot were made smaller (requiring a mirror of longer focal length), the corners and edges of the picture would be lost in darkness. As it is, the side-to-center distribution of light on the screen is only 55 to 80% when the standard elliptical mirror is used with the H-I arc. Due to the fact that the crater of this arc is a "hot-spot" crater, considerable fadeaway of screen illumination is produced even though the elliptical mirror is free from spherical aberration when arc and aperture occupy the foci of the imaginary ellipse.

Uniformity of screen light could be improved when the ordinary elliptical mirror is used by having an oversized spot (requiring a mirror of shorter focal length than is customary). But this expedient is a poor one, as all light which does not pass through the aperture is wasted.

Here we are at a "dead end," apparently. Even by eliminating all spherical aberration we are unable to obtain absolutely uniform screen illumination! Nevertheless, there is no reason to despair: several other types of mirrors are waiting to be given a trial.

'Antispherical' Aberration

Let us now try a mirror which produces the *exact opposite* of spherical aberration. This new kind of optical distortion may be called *antispherical* aberration; and the mirror which produces it, an *apospherical* mirror. Opticians may prefer other terms, but mere nomenclature cannot change the essential character of the mirror.

The apospherical mirror may be elliptical in form, or parabolic, or even hyperbolic, depending on the luminosity gradient of arc crater which serves as the source of light. We are primarily interested in two requirements: perfectly uniform screen illumination, and a mini-

(Continued on page 28)

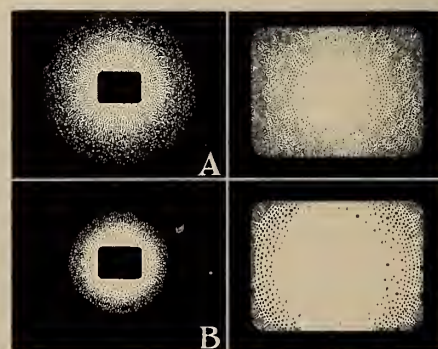

FIG. 3. The aperture "spot" and resulting screen illumination produced by *A* a spherical mirror, and *B* an ordinary elliptical mirror. The light-scattering effect of spherical aberration is seen in *A*; and the effect of non-uniform brilliancy distribution in the H-I crater in *B*.

Precision Engineering and Fine Projection
Craftsmanship Combine to make

GPL VIDEOFILM

the **FINEST** in



THEATRE TELEVISION!

Only VIDEOFILM
gives you these
EXCLUSIVE
Advantages

Full Screen Projection... Feature Film Brilliance
... Program Timing Under Management Control

Here is Theatre Television based on principles with which every projectionist is familiar . . . a system providing clearer, brighter pictures through the use of film in professional projection equipment. Operation is virtually automatic, may be readily fitted into your program routine.

Pictures and sound are flawlessly recorded on economical 16-mm film . . . completely processed in 40 seconds . . . are projected to full screen size, with brilliance and quality far surpassing ordinary television reception. Film is permanent, may later be cut, edited, shown again, or used in other theatres. This is television at its best—professional *Theatre Television*—a real attraction to build attendance performance after performance.

Developed, Built and Serviced by
People Who Know Your Industry

VIDEOFILM Theatre Television is a development of General Precision Laboratory, the research institute of General Precision Equipment Corporation. Installations are supervised, equipment serviced by Altec Service Corporation. Sold through National Theatre Supply, it is 100% the product of people who know your industry.

- Clear, bright, large screen projection
- Professional, high fidelity sound
- TV timed to your program requirements
- Permanent film for editing, re-showing, use in other theatres
- Automatic, trouble-free operation
- Unequaled film economy



NATIONAL

THEATRE SUPPLY

Division of National • Simplex • Bludworth, Inc.

Theater Television

via the RCA PT-100 Equipment

By TECHNICAL PRODUCTS DIVISION, RCA SERVICE CO., INC.

III. Formation of the Theater Tv Picture

THERE is one basic difference between the projection of motion pictures from film and from a television signal, as was pointed out in the first article of this series. The film picture is complete. Each frame consists of many thousands of fine grains of silver, so arranged that they form the dark portions of the picture. Each of these grains may be called an element of the picture.

The television picture, on the other hand, is formed as it is transmitted from the camera. Since a radio or wire channel can transmit only one bit of information at a time, it is necessary to completely go over the whole picture, part by part, and transmit information as to the relative brightness of each part to the receiver. The receiver must then build up a picture from the information which it receives from the transmitter.

Three Requisites for Process

Three things are necessary for this process. The receiver and the camera must both "scan" the picture in exactly the same manner, and they must do so at exactly the same time, in order to have the elements of picture formed by the receiver in the proper places to correspond with the original picture. Also, the receiver must produce brightness proportional to that of the transmitted picture at all points.

Practically, the picture is scanned in much the same manner as a person's eye scans a page of print. The electron beams in the camera tube and in the Kinescope are moved simultaneously from left to right across the top of the picture, then returned to the left side of the picture, but slightly below their original position, and again moved across the picture from left to right. The process is then repeated, with the beams starting out from the left side each time slightly lower than the preceding time, until they reach the bottom of the picture. Then they return to the top, and start the process over again.

As with a person's eye, which effectively sees nothing while returning from

right to left across the page, and from bottom to top, the scanning beams in camera and Kinescope are cut off while these beams make their similar returns.

Thirty complete pictures, or frames, are produced each second in our television system. However, it is desirable to reduce the flicker which would be produced by such a low picture rate. Increasing the number of frames per second would do this, but would complicate the transmission circuits in a cable system, and would occupy too many channels in a radio system. Therefore, an expedient equivalent to the flicker blade on a motion picture projector is utilized.

Two 'Fields' Per Frame

The frame is made up of two "fields," each of 1/60 second duration. This is accomplished by making the scanning beam travel over alternate lines as it goes down the picture. The first time it scans lines 1, 3, 5, 7, etc., forming the first field, and after reaching the bottom of the picture it returns to the top and scans lines 2, 4, 6, 8, etc., thus completing the picture after the second field. This method of scanning reduces the picture flicker below visibility.

In order to obtain and maintain absolute synchronism between the scanning beams in the camera and receiver tubes, a "trip," or synchronizing, signal is sent while the scanning beam is returning from the right side of the picture to the left, and while it is returning from the bottom of the picture to the top. Because the beam is cut off during these times, the synchronizing signal does not produce any interference in the picture.

As both beams are started from the left side of the picture, and from the top, at the same time, they will both be in the same position on the screen at all times, and therefore the receiver will produce its brightness changes at the same point as they are scanned in the camera, thus producing on the Kinescope screen a picture identical to that in the camera.

In order to produce a picture on a

large theatre screen, the image on the face of the Kinescope must be transferred to the screen. This is essentially the same thing that is done with a frame of motion picture film. Basically, this means that at every point on the theatre screen there must be produced an amount of light which is proportional to the amount which exists at the corresponding point on the film image, or, in the case of the television projector, the image on the face of the Kinescope.

In the film projector, light from the arclamp is passed through the film. After passing through the film, it goes into the projection lens. The lens has the property of bending light from any point on the film to a corresponding point on the screen. This is true regardless of the point on the lens surface where the light from any one point on the film image strikes it. However, the best projection lenses are not good enough to be used in a television projector, where the amount of light from the picture on the Kinescope screen is much smaller than that produced by an arclamp, as they would not catch enough light from the Kinescope image to produce a well-illuminated screen picture.

The RCA Optical System

The RCA PT-100 theatre television projector utilizes a reflection optical system which operates in a very similar manner to the mirror of a reflector arclamp. The Kinescope face, with its picture, occupies the same relative position as the positive carbon crater in such a lamp. The mirror is 26 inches in diameter. Because it is so much larger in diameter than the largest projection lens, and only about one foot from the Kinescope face, it can intercept much more light than the lens could. Thus, the amount of light which is reflected to the screen is greatly increased.

Light from any point on the Kinescope face will reach some part of the mirror. From there it is reflected to the screen. Light from the bottom of the Kinescope face will be reflected to the top of the screen; light from the top of the Kinescope face will be reflected to the bottom of the screen; therefore, the picture on

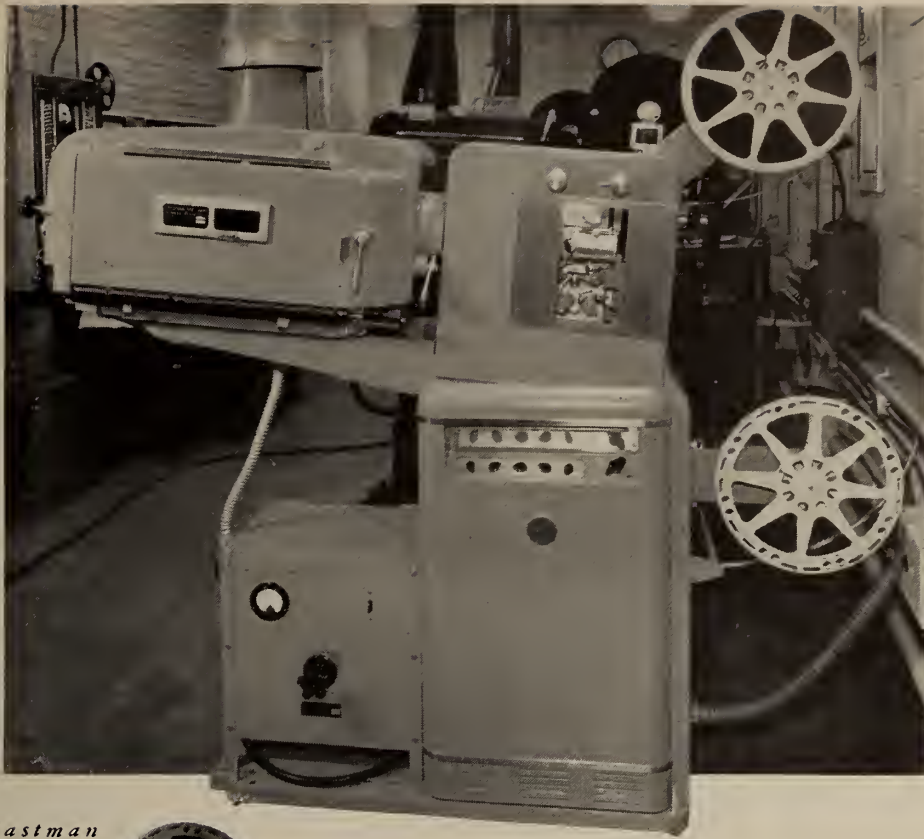

Left, the Eastman 16mm. Projector, Model 25, brings 16mm. projection to the professional level. Shown here, adapted for arc illumination, permanently installed alongside 35mm. equipment.

Below, working parts of the film movement mechanism are in constant view of the operator... readily accessible for threading and cleaning.

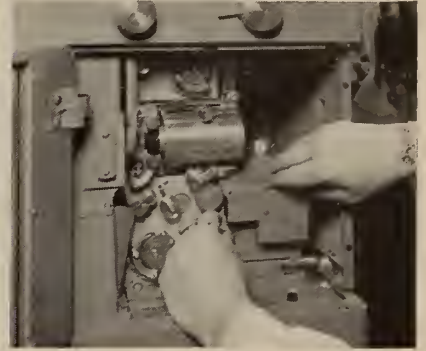

The Eastman 16mm. Projector, Model 25, adapted for 1,000-watt tungsten light.

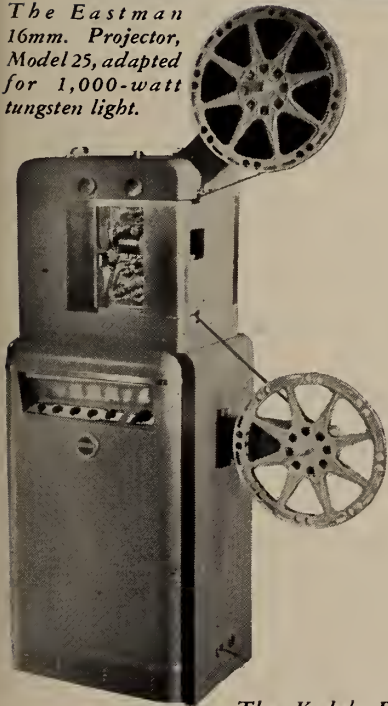

The Kodak Projection Ektar Lens, in a choice of four focal lengths, insures superior screen image.



East Coast Division
342 Madison Avenue
New York 17, N. Y.

For Professional Quality Sound Projection from 16mm. Film

The Eastman 16mm. Projector, Model 25

This projection instrument—built to a new design concept—eliminates the three major obstacles to theatrical quality 16mm. sound projection... excessive wear and high maintenance cost; low signal-to-noise ratio; and excessive flutter.

A major cause of excessive wear and poor quality sound is the constant transfer of shock forces generated in the film pulldown mechanism to other parts of the system. In the Eastman 16mm. Projector, Model 25, the intermittent (film advance mechanism) is completely isolated and independently driven by its own 1440 r.p.m. synchronous motor. Thus, shock forces are sealed off from the rest of the instrument. The sprocket-shutter system is driven by its own 1800 r.p.m. synchronous motor. Exact phas-

ing between the two systems is accomplished by specially designed synchro-mesh gears. In addition, the take-up spindle, rewind spindle, and blower are driven by separate motors.

A highly corrected microscope objective, adjustable for optimum sound quality from any type of 16mm. sound film, permits reproduction of variable area or variable density 16mm. sound tracks at extremely low distortion and a maximum signal-to-noise ratio.

To get the best out of any 16mm. sound film, project it on an Eastman 16mm. Projector, Model 25. For information on installation, availability, and prices, write directly to the Motion Picture Film Department, Eastman Kodak Company, Rochester 4, N. Y., or any branch office.

Motion Picture Film Department, Eastman Kodak Company, Rochester 4, N. Y.

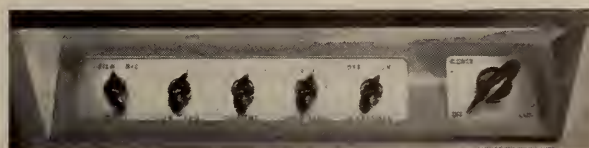

Midwest Division
137 North Wabash Avenue
Chicago 2, Illinois

West Coast Division
6706 Santo Monica Blvd.
Hollywood 38, California

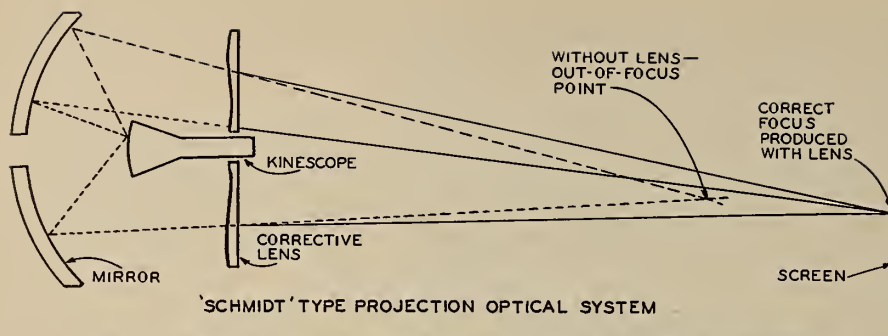

FIG. 1. The optical system for the RCA PT-100 Theater Television system.

the Kinescope screen must be produced upside down.

Light from the right and left sides of the Kinescope picture will similarly be reflected to the respective opposite sides of the screen, reversing the picture from left to right. The picture on the Kinescope face is therefore produced reversed from left to right. Thus, in spite of the use of a mirror instead of a lens, the picture on the Kinescope face is reversed from top to bottom and from left to right during projection, the same as a film picture projected through a lens.

A mirror has another advantage over a lens. Because the light which it reflects does not go through any glass (the mirror is coated with aluminum on its front side) there is theoretically no chromatic aberration—that is, light of all colors is reflected at the same angle. (In a lens, where the light goes through the glass, different colors are bent at different angles: this requires the use of different kinds of glass to obtain partial correction and nearly correct focus of different colors.)

Spherical Aberration Correction

There is one fault which is common to both mirrors and lenses—spherical aberration. It results in bending the light which strikes near the edge of the lens or mirror at a greater angle than the light which strikes nearer the center. Again, reducing this effect in a lens requires the use of several individual lenses. With a mirror, however, a single, thin lens will correct the condition.

This lens has a very special and peculiar shape, as depicted in Fig. 1. The

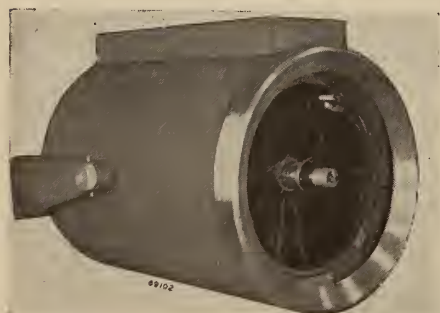

FIG. 2. Projection unit for RCA PT-100 system, usually mounted on the front of first balcony.

dotted lines show the path of the light as it travels to and leaves the mirror (it would continue to follow these lines if the lens were removed); the solid lines show it as it leaves the lens. Notice how all solid lines come together, or focus, at the same distance from the mirror, after the corrective lens has done its work, whereas the dotted lines focus at different distances from the mirror, as shown, if the lens were not used. Because this lens is very “weak,” it does not introduce appreciable distortion of its own.

Kinescope Light Controlling

Light from any one point on the Kinescope face may strike the mirror at any point; however, as in the case of the projection lens, it will be bent to reach the same point on the screen. The same thing is true for light from any other point on the Kinescope face: light from it will all reach the same point on the screen, regardless of where it strikes the mirror. This second point, of course, will be at a different point on the screen from the first one. The amount of light

at any point on the screen will be proportional to the amount produced at the corresponding point on the Kinescope face, therefore the picture on the Kinescope screen will be reproduced on the theatre screen.

Designed for ‘Average’ Throw

The curvature on the Kinescope face, the mirror, and the corrective lens are all dependent on the distance from the projector to the screen, or the “throw” distance. Therefore, it is necessary to assume an average throw distance and design the optical system for proper focus at this distance. The actual working distance may be increased or decreased above or below this design value by about 10% without appreciable loss of picture detail.

This somewhat limits the position which the optical barrel must occupy in a given theatre; usually, however, a position may be found on the standee rail, balcony front, or other suitable point, so that the throw will be within the acceptable limits. As no operating controls are located at the optical barrel, access to this unit during showtime is not required during normal operation. Fig. 2 shows the RCA PT-100 theatre TV projection unit.

To further increase the light from the screen, it is customary to use a special screen which reflects practically all light from the projector to the seating area.

[Note: The fourth article of this series will point out certain equipment features required by the nature of theater TV projectors, and wherein they differ from non-theatrical TV receivers.]

Projectionist Examination Questions

Based on Examinations by Leading U. S. Municipalities

1. What will cause a wire terminal to heat up?
2. Show by diagram two arcs connected to a 110-220 volt, two-wire circuit.
3. Show by diagram two arcs connected to a 110-volt, two-wire circuit.
4. What necessary appliances does the 110-volt D.C. arc pass through from the main switch to the arc?
5. Show by diagram a balanced load of two arcs, two meters, and two rheostats on a three-wire, 110-220 volt line.
6. Explain “voltage drop.”
7. Having an alternator with 12 poles and a speed of 1200 R.P.M. and a frequency of 60 cycles, at what speed must a synchronous motor travel to be in step with it if it has 8 poles?
8. If you had a 220-volt transformer with 50 amperes on the primary side and 110 volts on the secondary side, what amperage would you have on the secondary side, presuming that it had an efficiency of 90%?
9. Does the resistance of an ordinary wire conductor change if it is forced to carry current beyond its normal rated capacity?
10. How would you determine the size of the wire to be brought into a new theater to supply the projection and house lighting circuits?
11. How would you connect two transformers in series?
12. What is the resistance of a wire having a $3\frac{1}{2}$ -volt drop when carrying 45 amperes?



Are your lamps old enough to vote?

Switch now to **NATIONAL** TRADE-MARK **High Intensity Projector Carbons!**

VALUES IN "NATIONAL" PROJECTOR CARBONS

- Brightest, whitest light available in this size carbon
- Steadier burning, greater dependability
- Perfect color balance
- Complete technical service by National Carbon specialists
- Always readily available through your local dealer
- Economical to operate

If you are now using old-fashioned projection lamps of any type, get rid of them. Switch to the finest and most modern projection in the world, with "National" High Intensity projector carbons.

"National" "Suprex" carbons provide the brightest light for their size and current input that you can obtain. This light is perfect in color balance. It throws a vivid, detailed and thoroughly satisfactory picture on the screen.

When you buy projector carbons—
BUY "NATIONAL"

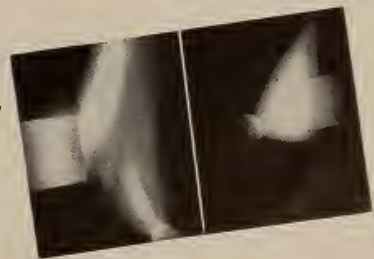

SLASH BATTERY COSTS IN HALF

With the revolutionary new "Eveready" No. 1050 Flashlight Battery you get these big exclusive features:

- More than twice as much light
- Whitest, brightest light available from a flashlight battery
- Half the cost for light output
- Leakproof—no metal can to leak or corrode
- Will not swell, stick or jam in a flashlight



Why? Because of the *exclusive* "inside-out" construction of the "Eveready" No. 1050 battery. Instead of being the container for the cell, the zinc electrode is on the inside to make the battery

last longer, while the new outside carbon jacket makes the battery leakproof. Order a supply of No. 1050's today.

The terms "National", "Suprex" and "Eveready" are registered trade-marks of

**NATIONAL CARBON DIVISION
UNION CARBIDE AND CARBON CORPORATION**

30 East 42nd Street, New York 17, N. Y.

District Sales Offices: Atlanta, Chicago, Dallas, Kansas City, New York, Pittsburgh, San Francisco
In Canada: National Carbon, Ltd., Toronto 4



**WHICH TWIN
IS THE
TROUPEUR?**

Give up? . . . well, in the center you have the Strong Trouper and at either side you see Micki Folger, also a real trouper and one of the reasons why so many thousands are flocking to see the current edition of "Holiday on Ice." (The photographer managed to get her in the above picture twice.)

The Strong Trouper High Intensity Arc Spotlamp (eight of which are used by "Holiday on Ice") has been widely adopted by not only ice shows but also theatres, night clubs, circuses, caliseums, schools, arenas, TV studios, and stadiums.

It assures a knife-sharp, dazzling snow-white spot. It's easy to operate. The automatic arc control maintains a constant arc gap, free from hiss or flicker. A trim of carbons burns one hour and twenty minutes at 21 volts and 45 amperes.

It draws only 10 amperes from any 110-volt A.C. convenience outlet and makes the use of heavy rotating equipment unnecessary. The adjustable, self-regulating transformer is an integral part of the base. The Strong Trouper is mounted on casters, is easily portable and as easily disassembled for shipping.

A horizontal masking control can be angled at 45 degrees in each direction. A color boomerang contains six slides and an ultra-violet filter holder.

The optical system utilizes a silvered glass reflector and a two-element variable focal length lens system.

SEE ANY OF THE FOLLOWING DEALERS OR USE COUPON FOR OBTAINING LITERATURE

ALBANY, N. Y.—Nat'l Theatre Supply Co.; Albany Theatre Supply
ATLANTA—Nat'l Theatre Supply Co.
ATLANTIC CITY—Boardwalk Film Enterprises
AUBURN, N. Y.—Auburn Theatre Equipment
BALTIMORE—J. F. Dusman Co.; Nat'l Theatre Supply Co.
BOSTON—J. Cifre, Inc.; Nat'l Theatre Supply Co.
BUFFALO—Dion Products; Nat'l Theatre Supply Co.
CHARLOTTE—Nat'l Theatre Supply Co.; Standard Theatre Supply Co.
CHICAGO—Abbott Theatre Equipment Co.; Gardner Jansen, Inc.; Hollywood Stage Lighting Co.; Midwest Stage Lighting Co.; Midwest Theatre Service and Equipment Co.; Nat'l Theatre Supply Co.
CINCINNATI—Nat'l Theatre Supply Co.
CLEVELAND—Nat'l Theatre Supply Co.
DALLAS—Hardin Theatre Supply Co.; Modern Theatre Equipment Co.; Nat'l Theatre Supply Co.
DENVER—Nat'l Theatre Supply Co.; Graham Bros.
DES MOINES—Nat'l Theatre Supply Co.
DETROIT—Nat'l Theatre Supply Co.
FORTY FORT, PA.—V. M. Tate Theatre Supplies
GREENSBORO, N. C.—Standard Theatre Supply Co.
HOUSTON—Southwestern Theatre Equipment Co.
INDIANAPOLIS—Nat'l Theatre Supply Co.
KANSAS CITY, MO.—Shreve Theatre Supply; Nat'l Theatre Supply Co.
LOS ANGELES—J. M. Boyd; C. J. Holzmuller; Nat'l Theatre Supply Co.; Pembrex Theatre Supply Corp.
LOUISVILLE—Falls City Theatre Supply Co.
MEMPHIS—Nat'l Theatre Supply Co.

MILWAUKEE—Nat'l Theatre Supply Co.; R. Smith Co.
MINNEAPOLIS—Minneapolis Theatre Supply; Nat'l Theatre Supply Co.
NEW HAVEN—Nat'l Theatre Supply Co.
NEW ORLEANS—Nat'l Theatre Supply Co.
NEW YORK CITY—Nat'l Theatre Supply Co.
NORFOLK—Nat'l Theatre Supply Co.
OKLAHOMA CITY—Nat'l Theatre Supply Co.; Oklahoma Theatre Supply Co.
PHILADELPHIA—Blumberg Brothers; Nat'l Theatre Supply Co.
PITTSBURGH—Atlas Theatre Supply; Nat'l Theatre Supply Co.
SALT LAKE CITY—Inter-Mountain Theatre Supply Co.
SAN FRANCISCO—C. J. Holzmuller; Nat'l Theatre Supply Co.; W. G. Preddy Theatre Supplies
SEATTLE—B. F. Shearer Co.; Nat'l Theatre Supply Co.

SIOUX FALLS—American Theatre Supply Co.
ST. LOUIS—City Electric Co.; Nat'l Theatre Supply Co.
TOLEDO—Theatre Equipment Co.
WESTERLY, R. I.—G. H. Payne Motion Picture Service
CANADA—
Dominion Sound Equipment, Ltd.
Montreal, Quebec
General Theatre Supply Co.
Montreal, Quebec
Perkins Electric Co., Ltd.
Montreal, Quebec
Perkins Electric Co., Ltd.
Toronto, Ontario
General Theatre Supply Co.
Winnipeg
Sharp's Theatre Supplies, Ltd.
Calgary, Alberta.

**THE
STRONG
ELECTRIC CORP.**
"The World's Largest Manufacturer of Projection Arc Lamps"
14 City Park Avenue
Toledo 2, Ohio

Please send free literature and prices on the Strong Trouper Spotlamp.

NAME _____
COMPANY _____
STREET _____
CITY & STATE _____

Motion Picture

and

Television Screens[†]

By FRANCE B. BERGER
General Precision Laboratory

Two fundamental factors, brightness gain and reflectance or transmittance, determine the suitability of a screen material in any particular application. High brightness gain, which necessarily implies a narrow viewing angle, may be desirable in one application but not in another. The reflectance or transmittance of the screen material is a measure of the light efficiency. Comparative figures for several commonly used screen materials are presented. Both front and rear projection screens are considered. The figures are considered to be within 5%, reasonable agreement with the few published figures available.

AT VARIOUS times in the past we have needed quantitative information regarding particular screen materials used in motion picture and television projection. A search of the literature on the subject revealed very few published figures and very little uniformity in the nature of the figures chosen for presentation.

The lack of uniformity may be attributed to the fact that there are several systems of photometric units in common use, and, further, that certain photometric terms have been defined differently by various authors. The necessity for subsequent interpretation of published data detracts from the value of the information.

The brightness of a screen as viewed by an observer depends not only upon the illumination falling on the screen but also upon the directional properties of the screen. Observers at different positions in the audience may see different brightness levels, depending upon the angle from which they view the screen.

The screen's performance in this respect is governed by certain fundamental optical properties of the screen material. Before these properties can be discussed, though, optical terms which apply alike to all projection screens should be defined. Following the definitions, the basic optical characteristics will be described in as non-mathematical a manner as possible. An exact treatment requires a mathematical approach, but since the mathematics may often obscure the physi-

cal concepts under discussion, they are relegated to appendixes.

General Screen Characteristics

Of the total incident light projected onto a screen, some is transmitted through the screen, some is reflected or scattered from the screen, and the rest is absorbed by the screen. The fraction of the total incident light that passes through the screen is called the *transmission factor* or the *transmittance* of the screen. The fraction which is reflected from the screen is called the *reflection factor* or the *reflectance*. The fraction which is neither transmitted nor reflected is called the *absorbance*.

These three quantities are often expressed as percentages, their sum being, of course, 100%. For a front projection screen a large reflectance is desirable, and the transmittance is generally small. For a rear projection screen, large transmittance and small reflectance are desirable. The absorbance should be small in either case.

The color of a screen depends upon the spectral composition of the light pro-

jected onto the screen, and also upon the reflecting or transmitting properties of the screen material itself. Strictly speaking, the transmittance, the reflectance and the absorbance of a screen depend upon the wavelength of the incident light.

For most purposes a projection screen should be "white," that is, it should reflect or transmit to the same extent light of all visible wavelengths. For the present purpose we shall assume that we are dealing with white light and with white screens.

Specular, Diffuse Materials

A screen material may be characterized as either specular or diffuse. The light transmitted by a sheet of glass, which passes through unchanged in its direction of propagation, is an example of *regular transmission*. The light reflected by a mirror leaves at a definite angle with relation to the angle of the incident light. Such reflection is referred to as *specular*. For convenience the term *specular* will be used in referring to either regular transmission or specular reflection.

In contrast to specular effects, a beam of light falling on a blotter is reflected from the illuminated spot in all directions. A beam of light passing through a sheet of ground glass emerges in all directions. Such reflection and transmission are commonly referred to as *diffuse*. Diffusely transmitted or diffusely reflected light is referred to as *scattered* light.

Both the transmittance and the reflectance of a material can be separated into two parts, the specular and the diffuse. When this distinction between specular and diffuse transmittance or reflectance is not made, the term *total transmittance* or *total reflectance* may be used to so indicate. Most materials that are suitable for projection screens have small specular coefficients, and one simply refers to the "transmittance" or "reflectance" of the screen.

Polar Distribution Data

The relative amount, or intensity, of light scattered in the various directions is conveniently represented by a polar distribution diagram. Different screens have different scattering properties and are, therefore, represented by different distribution diagrams. A distribution diagram such as in Fig. 1A characterizes a diffusely-transmitting screen. A screen material having appreciable specular trans-

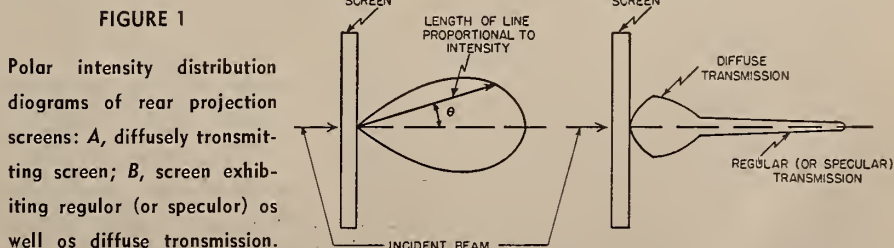

[†] J. Soc. Mot. Pict. and Tv Eng., August, 1950, p. 131.

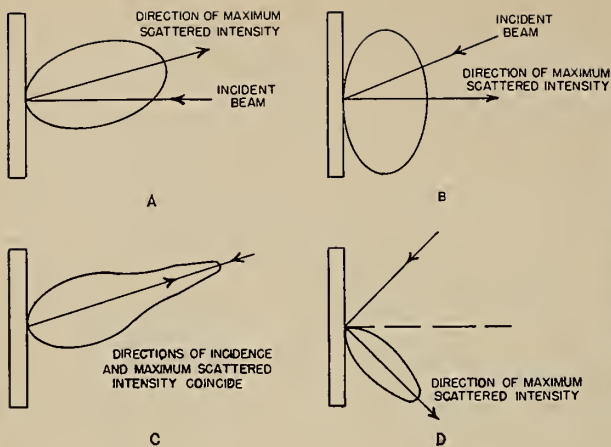

FIGURE 2

Some of the possible types of intensity distributions for front projection screens: A, medium brightness gain screen with pattern asymmetrical with respect to the normal; B, diffusing screen with brightness gain less than unity; C, behavior typical of beaded screens; D, high brightness gain screen exhibiting marked specular behavior characteristics.

mission in addition to diffuse transmission is represented by Fig. 1B.

Strictly speaking, polar distribution "diagrams" must be three-dimensional diagrams and the distribution "curves" are really surfaces. If the distribution is symmetrical about the normal to the surface, a simple plane diagram completely describes the directional scattering properties of the screen. If the distribution is unsymmetrical, and many practical screens have such unsymmetrical directional characteristics, the distribution is commonly represented by two plane diagrams: one for the distribution in a vertical plane, the other for the distribution in a horizontal plane.

In the examples cited, it has been tacitly assumed that the maximum intensity of the scattered light is observed in the direction normal to the screen surface. This may often be the case, but is by no means always true. In particular, if the direction of illumination is oblique to the screen surface, the maximum illumination is often observed to be in a direction other than normal to the screen surface. Certain possible situations are represented by the diagrams in Fig. 2, which pertain to front-projection screens.

Choice of Screen Material

The choice of a screen for use in a given situation depends on how the audi-

ence is distributed about the screen. The screen should direct as much light as possible toward the audience, and as little light as possible in other directions. A screen which is "tailored" to the audience

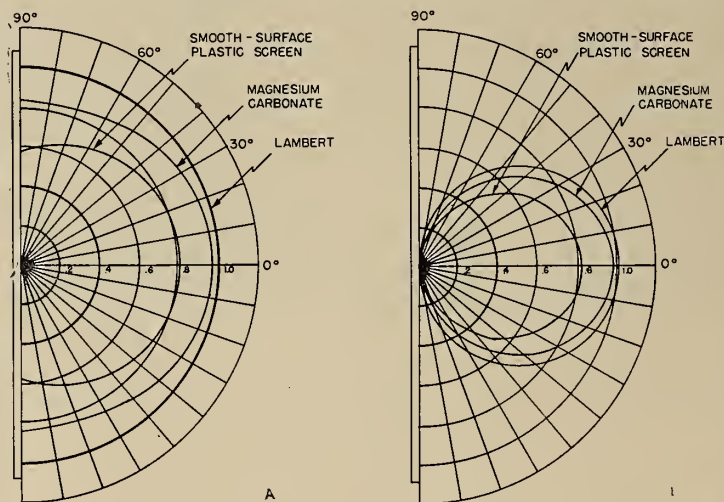

FIGURE 4
Brightness and intensity patterns for a "perfect" screen and the smooth surface plastic screen. On the brightness diagram, A, the radial scale gives foot-Lamberts per foot-candle; on the intensity diagram, B, radial scale gives candles per π square feet of screen area per foot-candle of illumination.

will make the most efficient use of the available light from the screen.

It is evident that the vertical and the horizontal distribution diagrams of the screen need not be the same. A screen which confines the scattered light to the minimum vertical and horizontal angles

consistent with the particular requirements will have maximum usable brightness gain. A screen with a lower brightness gain will not utilize the available light to the greatest advantage.

A screen which appears equally bright to all observers within the intended region of coverage of the screen and which has zero brightness to observers situated outside this region cannot be achieved in practice. Screen materials can, however, be chosen to approximate this condition reasonably well.

Parameters which are useful in making such a choice are the horizontal and vertical angles of coverage. The brightness gain of a screen is related to these angles of coverage, usually defined as the angles between the directions in which the screen has half its maximum brightness.

Incident Light Characteristics

It is frequently assumed that the light incident on the screen comes from a

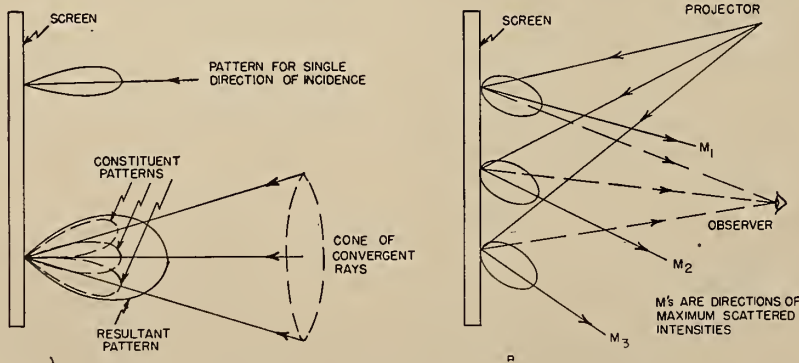

FIG. 3

A diagrams the broadening of the intensity diagram that results when light is incident over an appreciable range of angles; B illustrates the variation in relative brightness accompanying a variation in angle of incidence across the screen.

single well-defined direction. This assumption should, however, be used with care. In practice, the light incident on any point of the screen consists of a cone of rays coming from the projection lens aperture and converging at the point on the screen. Further, the rays falling on the edges and corners of the screen have a different angle of incidence than the rays at the center.

In motion picture projection, the cone of rays converging at any point on the screen is very small, and the rays to opposite corners of the picture make a rather small angle with each other. Moreover, low brightness gain (wide angle) screens which closely approximate Lambert scatterers are generally used. Therefore, in motion picture practice, the assumption is valid.

In television projection, on the other hand, the angles involved are quite large and high-brightness-gain screens are generally employed. The range of angles of incidence of the light rays at the screen may be comparable to or larger than the

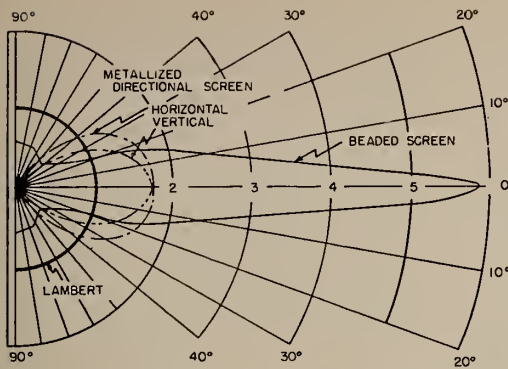

FIGURE 5

Brightness patterns for a typical beaded screen and for a metallized screen. The pattern for a "perfect" screen is shown for comparison. The radial scale is graduated in foot-Lamberts per foot-candle of illumination.

angular width of the distribution diagram. When the incident convergent cone of rays is large, the effective distribution diagrams are broadened and the effective brightness gain is lowered, as shown in Fig. 3A.

When the angle of incidence changes sufficiently over the screen area, the distribution diagram differs correspondingly for different regions of the screen. This generally will result in nonuniform brightness over the screen area, the effect becoming more noticeable at high brightness gain figures and at large oblique viewing angles. Curved screens, auxiliary optical elements such as a Fresnel lens, non-homogeneous screens, or other innovations may offer advantages in these cases.

Table I gives the results of laboratory measurement on a number of screens and of several miscellaneous materials. Some of the materials were measured by the intensity method and others were measured by both the intensity and the

brightness methods. All data presented refer to measurements made with incident illumination normal to the screen surface. All of the screens are homogeneous, except the ribbed plastic screen with Fresnel lens; measurements on the latter pertain to the central region only. Some of the laboratory measurements are presented in Figs. 4 and 5.

List Requisites for Survival of the Motion Picture Theater

"Although home Tv seems to be acquiring a mass audience," Benjamin Schlanger and William Hoffberg, theater architectural and engineering consultants, told the recent SMPTE meeting, (Fall, 1950, convention at Lake Placid, N. Y.) "there will always be a motion picture theater and theater Tv audience consisting of those who wish to see entertainment not available in other mediums; those who wish to avoid advertising in-

trusions; those desiring a respite from home entertainment; those satisfying their gregarious instincts, and those who prefer the dramatic impact of the large theater screen cinematography."

New and existing theaters which offer the seating, air conditioning, projection and sound transmission comforts now available, and which add to these the increased screen image, the luminous screen field, the increased flexibility and scope of motion picture cinematography, the feelings of intimacy within the auditorium, and stereoscopy of sound and vision, should survive within the forests of home antennae, they concluded.

New Optical Theory Described

A new mathematical theory expected to be an aid to lens designers was described recently by Dr. Max Herzberger at a physical colloquium at Syracuse University. Dr. Herzberger is a scientist at Kodak Research Laboratories. His new formula is said to provide a complete solution for image errors in lens systems.

Exact Computation Possible

Basically, the theory reduces the various possible errors for each light ray passing through a lens system to two errors which can be computed exactly. When one of these errors is eliminated, a symmetrical image is formed. Removal of both errors gives a sharp image. The theory is a generalization of the Seidel image-error theory. It will be valuable in the design and evaluation of lenses because it will allow a lens designer to learn the limitations of a new lens system while it is still on the drawing board, Dr. Herzberger said.

Dr. Herzberger is the author of *Strahlenoptik* (Ray Optics), published in Berlin in 1932, and of 150 papers in the field of geometrical optics and mathematics. He holds several patents dealing with optics and photography.

More Stringent Copper Restrictions

March 1 is the effective date for the stringent copper conservation order issued recently by the NPA. The order permits the use of copper where it serves a "functional" purpose and where no practical substitute is available. It will not be used where it is non-functional—that is, for ornaments or decorative purposes. Previous NPA actions on copper, providing for use of a certain percentage of the total used in previous years, remain in force.

Netter Heads Altec Service Sales

L. D. Netter, Jr., has been appointed general sales manager for Altec Service Corp. In addition to his responsibilities to the service company, Netter will oversee product sales made by the company in its role as manufacturer's sales agent for Altec Lansing Corp. Netter joined Altec in Nov., 1947.

TABLE I. Characteristics of Representative Screen Surfaces

Screen	Brightness Gain	Reflection	Transmittance	Effective Brightness Gain
<i>Miscellaneous Materials</i>				
Perfect screen	1.0	100	100	1.0
Magnesium carbonate	1.1	88	—	0.97
Traceolene paper	13.6	—	87	11.8
Opal glass	1.0	—	48	0.48
White blotting paper	1.4	61	—	0.85
Brushed aluminum	4.5	65	—	2.9
<i>Motion Picture Screens</i>				
Smooth-surface plastic (perforated)	1.15	72	—	0.83
Beaded	16.4	35	—	5.7
Nylon cloth	1.2	49	—	0.6
Metallized directional (perforated)	2.5	70	—	1.8
Glass cloth	1.7	47	—	0.8
<i>Commercial Television Screens</i>				
Translucent plastic #1	12.	—	54	6.5
Translucent plastic #2	6.2	—	62	3.9
Diffusing cloth	4.2	—	47	2.0
Diffusing glass	5.1	—	70	3.6
Ribbed glass	7.0	—	49	3.2
Ribbed plastic with Fresnel lens	8.0	—	43	3.2
Metal beaded	7.5	61	—	4.6

Maintenance and Servicing of Motors

By ROBERT A. MITCHELL

The fourth and concluding installment of a series of articles on the types of motors used in the projection field, with special emphasis upon the recognition and correction of various troubles encountered.

CHART II. POLYPHASE INDUCTION MOTORS

1. BEARINGS TOO HOT

Trouble: Bearing dry. *Cause:* Insufficient lubrication; oil rings not working. *Remedy:* Clean bearings with kerosene, flush with oil, then refill with fresh oil or grease of the proper type. Check action of oil rings.

Trouble: Bearing dirty. *Cause:* Dust or dirt in oil or grease. *Remedy:* Wash out oil or grease reservoir with kerosene and refill with the proper lubricant.

Trouble: Tight bearing. *Cause:* Provide clean lubricant, replace rings with rings not too tight. (If ring sticks or runs slowly, bevel it with a fine file.) Polish shaft with emery paper, or replace bearing.

Trouble: Bearing binding. *Cause:* Sprung shaft. *Remedy:* True the shaft in a lathe and replace the bearings.

Trouble: Loose bearing. *Cause:* Vibration and wear. *Remedy:* Tighten screws which hold bearing. Replace bearing.

2. ENTIRE FRAME TOO HOT

Trouble: Transference of heat from bearings, rotor, or stator. *Causes and Remedies:* See directly following, and Causes and Remedies under Symptoms 1, 3, 4, 5, 6, and 7.

Trouble: Heat transferred from rotor or stator. *Cause:* Motor overloaded. *Remedy:* Test each phase with an ammeter, and if readings are abnormally high, reduce the load or obtain more powerful motor.

Trouble: Motor running single-phase. *Cause:* One fuse blown, or one overload relay out of order. *Remedy:* Replace fuse or adjust relay and take ammeter readings of each phase.

3. SMOKE ISSUES FROM ROTOR WINDINGS; WEDGES OVER CERTAIN COILS ARE CHARRED

Trouble: Rotor not centered in stator. *Cause:* Bearings worn. *Remedy:* If noticed before coils are damaged, renewal of the bearings and inserting new wedges will correct the fault; otherwise coils will need to be replaced.

4. EVERY THIRD COIL IN A 3-PHASE MOTOR STATOR IS HOTTER THAN ADJACENT COILS

Trouble: Insufficient impedance in phase which is hottest, causing unbalanced currents in phases. *Cause:* One or more coils of one phase short-circuited within themselves. *Remedy:* Replace short-circuited coil. (Do not jump the coil!)

Trouble: One phase grounded inside motor. *Cause:* Dampness or damage. *Remedy:* Eliminate ground by lifting coil and re-insulating.

5. MOTOR RUNS HOT, AND EXPLOSIONS, SOMETIMES ACCOMPANIED BY FIRE, OCCUR IN WINDINGS

Trouble: Temporary ground or short-circuit. *Cause:* Dampness, which allows currents to circulate between coils and between any coil and ground. *Remedy:* Bake rotor and stator until all dampness disappears, then paint all coils with insulating varnish (which needs to be baked) or Glyptol (which dries in air). If coils are punctured, replace with new coils.

6. STATOR COILS OF ONE OR MORE PHASES HOT IN SPOTS, WHILE COOL IN OTHERS

Trouble: Part of windings inoperative. *Cause:* Short circuits between adjacent stator coils. *Remedy:* Replace short-circuited coils, as they will usually be found to be badly burned.

7. MOTOR RUNS, BUT ROTOR HEATS UP WHILE THE STATOR IS COOL

Trouble: Abnormal currents in rotor.

Cause: Rotor bars loose or grounded; wound rotors short circuited. *Remedy:* Tighten set screws holding rotor bars to short-circuiting rings; replace wound rotors.

8. MOTOR REFUSES TO START, BUT MAKES A HUMMING SOUND

Trouble: Motor tries to run single-phase. *Cause:* One fuse blown, or overload relay out of order. *Remedy:* Replace fuse or adjust relay.

Trouble: Rotor not centered in stator. *Cause:* Bearing worn or out of adjustment. *Remedy:* Center the bearing, and replace worn bearings.

Trouble: Open circuit in stator windings. *Cause:* Coil damaged. *Remedy:* Replace faulty coil.

9. MOTOR ISSUES A PECULIAR SOUND WHEN RUNNING LIGHT, AS IF A HEAVY LOAD WERE THROWN ON PERIODICALLY, WITH A SLIGHT SLACKENING OF SPEED AT THESE INTERVALS

Trouble: Coil connections of one phase reversed. *Cause:* Connected wrongly when repaired. *Remedy:* Connect coil to its proper group, and in correct polarity.

10. MOTOR LOSES POWER AND SPEED WHEN FULLY LOADED

Trouble: Rotor to one side of magnetic center of stator. *Cause:* End play all taken up at one end of shaft; motor out of level; coupling driven too far on shaft if direct coupled. *Remedy:* Readjust end play so that rotor will "float." Level motor. Bring coupling out to restore floating of rotor.

CHART III. SINGLE-PHASE INDUCTION MOTORS

Including Split-Phase, Capacitor, and Repulsion-Induction Types

1. BEARINGS TOO HOT

Trouble: Bearing Dry. *Cause:* Insufficient lubrication; oil rings or wool wick not working. *Remedy:* Wash bearings and wicks in kerosene, flush with oil, then refill with fresh oil or grease of the proper type. Check action of rings.

Trouble: Bearing dirty. *Cause:* Dust or dirt in oil or grease. *Remedy:* Wash out oil or grease reservoir with kerosene and refill with proper lubricant.

Trouble: Tight bearing. *Cause:* Insufficient lubrication, grit in oil, oil rings not working, undersized bearing if bearing has been replaced. *Remedy:* Provide clean lubricant, replace rings with rings not too tight. (If ring sticks or runs slowly, bevel it with a fine file.) Polish shaft with emery paper, or replace bearing.

Trouble: Bearing binding. *Cause:* Sprung shaft. Too much strain on pulley. *Remedy:* True the shaft in a lathe. Shim the bearing with thin pieces of tin as a temporary expedient. Install new bearings.

Trouble: Loose bearing. *Cause:* Vibration and wear. *Remedy:* Tighten set-screws holding bearing. Replace worn bearings.

2. ENTIRE FRAME TOO HOT

Trouble: Transference of heat from bearings, rotor, or stator. *Causes and Remedies:* See directly following, and also Causes and Remedies under Symptoms 1, 3, 4, 5, and 6.

Trouble: Heat transferred from rotor or stator. *Cause:* Motor overloaded. *Remedy:* Lighten load, or use a larger motor.

Trouble: Motor running on starting winding. *Cause:* Frequency too low. Centrifugal switch stuck or capacitor shorted. *Remedy:* Turn motor off immediately to avoid burning up the starting winding! Use proper motor for line frequency, repair centrifugal switch by cleaning, oiling lightly, and operating by hand a few times. Replace capacitor. Inspect stator windings for possible damage.

Trouble: Motor heats up even though load is light, and centrifugal switch and

other auxiliary apparatus are in perfect working order. *Cause:* Rotor not centered in stator. *Remedy:* Replace bearings and align them properly. (There should be an all-around clearance of 0.015 to 0.030 inch between rotor and stator poles.)

3. ONE SECTION OF THE STATOR WINDING HOTTER THAN OTHER PARTS

Trouble: Short-circuited stator winding. *Cause:* Worn or deteriorated insulation; mishandling. *Remedy:* Renew the short-circuited winding.

4. MOTOR RUNS HOT, AND EXPLOSIONS, SOMETIMES ACCOMPANIED BY FIRE, OCCUR IN THE WINDING

Trouble: Temporary ground or short circuit. *Cause:* Dampness, which allows currents to circulate between coils or between any coil and ground. *Remedy:* Bake rotor and stator until all dampness disappears, then paint all coils with insulating varnish (which must be dried by baking in an oven at 115° C., or 239° F.) or Glyptol (which dries in air at room temperature). If coils are punctured, replace with new coils or have the stator rewound.

5. MOTOR RUNS, BUT ROTOR HEATS UP, WHILE STATOR REMAINS REASONABLY COOL

Trouble: Abnormal currents in rotor. *Cause:* Squirrel-cage rotor bars loose. *Remedy:* Tighten set screws holding rotor bars to short-circuiting ring. (Most fractional H.P. motors have bars welded or soldered to the short-circuiting ring, making this trouble impossible.)

6. REPULSION ARMATURE WINDING (ON CERTAIN TYPES OF REPULSION-INDUCTION MOTORS) HEATS UP

Trouble: Brushes not disconnected when motor picks up speed. *Cause:* Centrifugal switch not functioning. *Remedy:* Overhaul switch, oil sparingly, and operate it by hand a few times. Check tension springs.

7. BRUSHES (OF CERTAIN TYPES OF REPULSION-INDUCTION MOTORS) DO NOT LEAVE COMMUTATOR WHEN MOTOR IS NEARLY UP TO NORMAL RUNNING SPEED

Trouble: Governor fails to function. *Cause:* Overload, low voltage, wrong frequency, governor sticking. *Remedy:* Run motor "light" to see if governor functions; decrease load or increase size of motor. Test line voltage; use motor designed for line voltage and frequency. Wipe excess oil from governor, apply kerosene sparingly, loosen springs.

8. BRUSHES ON COMPENSATED WINDING (OF CERTAIN OTHER TYPES OF REPULSION-INDUCTION MOTORS) DO NOT MAKE CONTACT WITH COMMUTATOR WHEN MOTOR IS NEARLY UP TO SPEED

Trouble, Cause and Remedy: See No. 7.

9. ABNORMAL ARCING AT BRUSHES OF REPULSION-INDUCTION MOTORS

Trouble: Short circuit in armature coil. *Cause:* Carbon between commutator bars, insulation burned from leads connecting segments to armature, short circuit in one or more armature coils. *Remedy:* Undercut mica between segments with slotting tool, bevel slightly the edges of the copper bars, and then paint the exposed mica with glossy red enamel of the iron oxide or synthetic type. Securely tape all leads. Rewind or renew armature.

Trouble: Loose contact between the short-circuiting segments and commutator in certain types of repulsion-induction motor. *Cause:* Segments jammed in holders. *Remedy:* Sandpaper the segments and commutator with 00 sandpaper (NOT emery paper!) and see that the short-circuiting segments are not sticking.

Trouble: Loose contact between short-circuiting brushes and commutator in certain other types of repulsion-induction motor. *Cause:* Brushes too short or sticking in holders. *Remedy:* Renew worn brushes. Work brushes in holders until brushes are loose. Sandpaper commutator and brushes.

10. SPEED OF MOTOR FLUCTUATES

Trouble: Centrifugal switch or brush governor cuts in and out frequently. *Cause:* Switch or brush-actuating mechanism not properly adjusted. Low voltage. Poor switch contacts. *Remedy:* Wait for voltage to come up to normal. Adjust tension springs, repair loose connections, clean switch contacts.

Trouble: Line voltage or frequency erratic. *Cause:* Beyond control of operator. *Remedy:* None. This condition usually corrects itself after a few moments.

11. MOTOR FAILS TO START

Trouble: Load too great. *Cause:* Motor too small for load; friction. *Remedy:* Obtain a motor suitable for the load. Examine motor bearings, couplings, and mechanical condition of driven machinery.

Trouble: No current. *Cause:* Blown fuse; line open. *Remedy:* Inspect fuse and replace, if necessary. Test line, repairing any breaks which may be discovered. Test motor leads.

Trouble: Open circuit in stator. *Cause:* Rough usage, or burned coil or connection which may have opened. *Remedy:* By means of a circuit-tester locate the defective coil, which must be replaced. (Do not jump the open coil!)

Trouble: Open circuit in armature. *Cause and Remedy:* See directly above.

Trouble: Rotor rubbing on stator core. *Cause:* Worn bearings. *Remedy:* Readjust (shim) the bearings or, better, replace the bearings with new ones.

Trouble: Brushes of repulsion-induction motors not in contact with commutator. *Cause:* Brushes too short, or brushes stuck

in holders. *Remedy:* Renew all brushes, which should all be of the same length. Work brushes in holders to loosen them, or sandpaper brushes. Sandpaper commutator with No. 00 sandpaper (NOT emery paper).

Trouble: Consistently poor commutation. *Cause:* Brushes on a neutral point. *Remedy:* Shift the brushes to the side of "hard neutral" which gives the proper direction of rotation.

Trouble: Motor makes loud humming sound, but refuses to start. *Cause:* See directly above. Also, centrifugal switch of split-phase and of certain capacitor and repulsion-induction motors not functioning. Starting winding burned out, starting resistor open, capacitor shorted, or armature windings of repulsion types burned out. *Remedy:* Repair, adjust, and clean governor and centrifugal switch. Test starting winding of stator or repulsion-induction armature coils, replacing burned-out coils or rewinding same. Test starting resistor. Test capacitor with a D.C. testing outfit. Replace any defective components.

12. MOTOR RUNS BACKWARD

Trouble: Initial, or starting, torque turns rotor in wrong direction. *Cause:* In the case of repulsion-induction motors, brushes have been shifted to the wrong side of "hard neutral." *Remedy:* Loosen set screws holding brush-holder rocker and shift rocker to the correct side of the neutral point.

Warners' 27 Months to Divorce in U. S. Consent Decree

Warner Brothers has 27 months in which to divorce production-distribution from exhibition and to form two new companies, and up to two years in which to dispose of a maximum of approximately 80 of its theaters, under the terms of a consent decree with the U. S. government which concludes the 12-year anti-trust suit against the film company.

Highlights of the decree, patterned closely after the recent Paramount settlement with Uncle Sam, are:

Jan. 4, 1951, the Effective Date

The present Warner Brothers organization will be recast into separate production, distribution and theater companies within 27 months from Jan. 4, 1951.

Disposal of from 55 to 80 theaters is required, depending upon the number of competitive theaters playing first-run product on a regular basis in Warner towns and cities.

The three Warner Brothers and their families must dispose of their holdings in one or the other of the new companies within 27 months, or put them under control of a U. S. court-appointed trustee.

Trade practice restraints in the distribution of films—franchises, pooling deals, profit-sharing leases, etc.—are imposed.

CURRENT WITHOUT CONDUCTORS: When we think of electric current or electrons in motion, we customarily associate the current with some confining medium or transporting path, as, for example, a wire: a commonplace condition in electrical circuitry, yet not necessarily a "must" condition. In other words, it is not necessary that a metallic conducting path be present in order that electrons flow in a directed path and constitute electron current.

The operation of a vacuum tube demonstrates that a metallic conducting path is not essential: the grid, plate, and screen current within the tube advance through

these effects inside of many vacuum-tube devices.

For example, an important attribute of the electron in motion is a magnetic field which surrounds the moving charge. Seldom do we pay any heed to this phenomenon in a high-vacuum rectifier tube, in an amplifier tube, or in an oscillator tube.

Admittedly, the movement of electrons through such devices is not in the form of a concentrated beam; if it were so, there might possibly be a remote association with a similar current through a wire. In the case of the cathode-ray tube, however, the electrons are confined into a narrow path; therefore, there is a

that case because the ordinary manner of application of such tubes does not require recognition of this field. In the cathode-ray tube, not only does the magnetic field demand recognition, but it also is put to good use.

Stationary Charges

Not all of our dealing with electrons in connection with the operation of the cathode-ray tube are restricted to charges *in motion*—that is *dynamic* electricity. A good deal of what takes place within the cathode-ray tube is the result of the behavior of electrons *at rest*, of the positive charge at rest.

While it is true that we cannot create

The Cathode-Ray Tube: Basic Data

By JOHN F. RIDER and SEYMOUR D. USLAN

II. Electrostatic Deflection and Focusing

Second of a series*, this installment relates to the basic theory anent electrostatic action—data with which all professional projectionists should be familiar if they hope to cope with the ever-increasing complexities of electronically-controlled systems. Originally appearing in *Encyclopedia on Cathode-Ray Oscilloscopes and Their Uses*, these data are presented here through the gracious cooperation of John F. Rider**, publisher of the massive (982-page) aforementioned authoritative work.

"space" without benefit of conducting paths. The physical conducting paths appear at the elements and the circuits connected to the elements. The cathode-ray tube is another example of electron flow through space.

These references to conductorless paths for current should not be construed as implying that a so-called open circuit is an operative system. Direct electron flow through space occurs only under proper conditions. Here, we are concerned solely with electron currents identified as conduction currents when they advance through wires; and we take for granted that wire circuits as paths are complete in every respect. We raise this point because the properties of electron currents as associated with wire conducting systems are applicable to like currents which are traveling through space.

Influence of Magnetic Field

We speak freely about vacuum-tube currents as being electrons in motion, but we seldom think of them as having the properties of current in a wire because we have no occasion to consider

closer similarity between a stream of electrons moving through a wire and one advancing through this tube.

But it is not this similarity which forces us to stress the condition. Instead, it is that the electron stream within the cathode-ray tube not only possesses every property of an electron current, especially the associated magnetic field, but also that the operation of the tube depends in part upon several phenomena which are tied-in with the magnetic field.

Electromagnetic focusing would be impossible without the magnetic attribute of the electron beam. The same, is true, of course, as far as electromagnetic deflection is concerned.

The absence of a concentration of electrons in a vacuum tube does not remove the electron stream from the conditions described as the basic laws of electricity and magnetism as applied to electric current—those conditions which are, of necessity, associated with the beam of electrons in the cathode-ray tube. Both are governed by identical law; it is just that these laws are of more immediate interest in the cathode-ray tube than in the ordinary vacuum tube.

Electrons advancing through a conventional vacuum tube are surrounded by a magnetic field, but it is unimportant in

a positively-charged plate without first making electrons move away from that plate, leaving a residual net positive charge, we ordinarily ignore this transient motion of the electron. Conditions are considered only after the electron has come to rest somewhere else, where it sets up a negatively-charged surface.

If these statements remind you of "charged" bodies of surfaces, the basis of operation of the conventional vacuum tube wherein the elements act as charged surfaces, or even the principle of operation of a capacitor, your thinking is along correct lines.

Many of the performance capabilities of the cathode-ray tube stem from the creation of a "charged" state in some of the components which are part of its structure. The electrostatic fields and lines of force existing between these charged surfaces account for such actions as electrostatic focusing and deflection, because they determine *the paths* of electrons which pass under their influence.

Taking into account the properties of current and the fields between charged surfaces, it is evident that the basis of focusing and deflection is the establishment of *certain paths* for the emitted electrons and the beam by these phenomena. A review of the basic principles of these actions is essential. This can be done most easily by grouping the actions into electrostatics and magnetics, and discussing each separately—limited, of course, to those subjects within each group which are most directly associated with the title of this text.

Electric Fields and Lines of Force

It is a basic law of physics that unlike charges attract, and that like charges repel, each the other. Originally, when it was noted that bodies bearing charges

* The first installment appeared in IP for Dec., 1950, p. 26.
** 480 Canal St., New York 13, N. Y.

reacted in a certain manner upon each other, the general approach was that some sort of "action at a distance" was taking place. Among the early investigators, Faraday was a strong objector to this philosophy. Eventually he conceived the idea that something existed *between* the bodies which displayed attraction and repulsion for each other. The result was the concept of electric fields and lines of force as being in the space between the objects.

Graphical presentations of the electric field and the lines of force are strictly mental devices, to assist in visualizing certain phenomena. Sometimes it is convenient to think of the field lines or the lines of force as having certain physical properties; but these properties are only explanations of *what* happens, not the *cause*.

By accepting these concepts as a working tool without trying to demonstrate validity, it will be easier to comprehend

the subject of fields, and in particular of electron lenses.

By an electrostatic field or electric field, the physicist means a special condition of space around every elemental charge of *either polarity*. By the special condition of space, the physicist means that energy, attributable to the charge, exists around it. Moreover, this energy is capable of exerting a force upon another charge.

The Vital 'Field of Energy'

Thus, every elemental charge, whether isolated in space or resting upon the surface of a body, is inseparably associated with an electrostatic field, which may be called a *field of energy*. Or, if we examine the condition from the viewpoint of the force which it may exert upon *another* charge, then the electrostatic or electric field is a *field of force*.

Since the field is one of energy or force, neither of which is a substance, the field is invisible, detectable only by its *effects*. Such effects are the forces which the field is capable of exerting upon something susceptible to it, and such a "something" is *another* charge or charges.

Now, recalling that every elemental charge has a field of its own, and placing a charge *A* within the field of another charge *B*: if we say that the field of *A* is capable of exerting a force upon charge *B*, we are stating only a part of the truth. In reality, charge *B* also has a field, so that the field of *A* is acting upon *B*, and the field of *B* is acting upon *A*.

When we speak about forces being present in a field and being the effect of the field, it must be remembered that this is a mutual condition involving all of the fields due to all of the charges. The manifestation of these forces is the action described by the basic laws of physics—the attraction between unlike charges and the repulsion between like charges.

Directed Quantity—a 'Vector'

Now, force not only has magnitude but is also a *directed* quantity—that is, it acts in a definite direction. (Such a quantity is called a *vector*.) If we say that a field is perceivable by its effects and these effects are forces, then the effects (forces) have *both* direction and magnitude. Here we have a clue to the means of representing the fields as a whole, or, rather, a means of illustrating the special condition of either the space around a charge, or the condition of space between charges.

What is done is to use lines which show the *direction of action* of the forces present in the field. We might describe these lines as being the paths of the force, or the paths over which the force

(Continued on page 25)

Cron-O-Matic Carbon Saver Utilizes New Principles

The Model U. N. Cron-O-Matic carbon-saver utilizes a completely new positive-carbon assembly and includes devices heretofore not employed with standard projection arclamps to effect an entirely automatic unit. Installation is extremely simple. All insulation being self-contained, the projectionist need only remove the old post and guide assembly, substitute the Cron-O-Matic, and discard the original insulation. Of universal design, the base casting is merely attached to the particular lamp for which it is intended.

The projectionist sets the "top" carbon by means of the gauge furnished (Fig. 1), installs a carbon stub of any length—from 1¼ to 6 inches (regardless of the number of minutes the film is to be projected), swings the carriage back to the operating position, closes the lamphouse door—and operates as usual.

The "swing-out" of the carbon head has been designed for quicker cooling of the carbons as well as for convenience in retrimming. No drilling of carbons, pins or sleeves is required, nor is it necessary to measure the stub against the running time.

Precise Alignment Assured

Under any circumstances, the stub is set back on the guide rest, ready for striking. The stub is in *exact* alignment with the negative: this is accomplished by raising or lowering the entire assembly and by lateral adjustment made possible by an eccentric.

Figure 2 illustrates how the stub has been consumed to the point where the tail-flame of the arc burns upward and onto the "top" carbon, preheating it to the same temperature as the stub. The carbon head, constructed of heat-resisting, non-magnetic alloy, is not damaged by the flame and has no effect upon the original setting of the permanent magnet.

In Fig. 3 is shown how the stub has dropped down out of the path of the now-burning "top" carbon. This drop is accomplished instantaneously due to a trip-spring inserted into the rear of the pivot action post. The "top" carbon will burn for 22 minutes at normal amperage for the given size used, making it impossible to run out of carbon on any full double reel of film.

Figure 4 shows the condition which exists after the "top" carbon has burned for 22 minutes at 65 amperes (8-mm carbons). It will be noted that the extension arm drops

harmlessly downward out of the way of the reflector.

The Cron-O-Matic carbon-saver is sold through theatre equipment supply houses everywhere. Detailed descriptive literature will be sent free to anyone upon request to the manufacturer, Payne Products, 2454 W. Stadium Boulevard, Ann Arbor, Mich.

FIG. 1

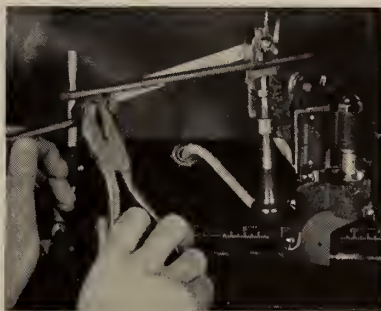

FIG. 2

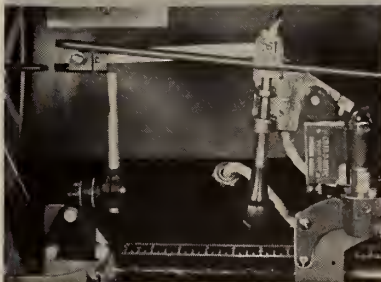

FIG. 3

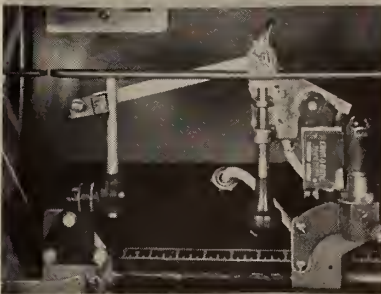
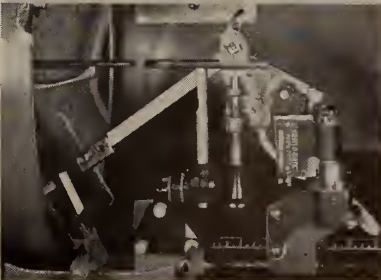

FIG. 4



IN THE SPOTLIGHT



By
**HARRY
SHERMAN**

ONE cannot read the recent government wage-price "freeze" order without experiencing mixed feelings of relief at some sort of action after weary months of delay and a "so-what-the-Hell" attitude mindful of the days of World War II in terms of too little, too late.

We motion picture people still have a potent publicity outlet *via* the newsreels, personal appearances of stars, charity sponsorships, collections, *etc.*—in short, anything smacking of glamour in terms of Podunk and all way stations to eject the stuffing from the soft cushions which soothe the Washington crowd into thinking that they can get away with anything.

Wage control without price control—bread, clothing, medicine, doctors' bills, and the thousand and one things necessary for the mere business of living—all these add up to the ultimate in governmental stalling and an appeal for votes come 1952 which will be overwhelmingly repudiated by the working men and women of America.

Wage control? Yes . . . but coupled with a control of the price structure that will enable the average JOE AMERICA to live and walk the streets of his native land in a manner befitting one who, we are told, is privileged (?) to vote for those who control his destiny by sheer weight of executive office.

No wage controls without price controls—that's our stand.

• Ernie Lang, recording-secretary for New York Local 306, recently notified the membership that the Local's Pension and Welfare Plan had been approved and put into effect. (See IP for Oct. 1950, p. 19.) This plan, which affects members working in major circuit theaters, Broadway houses, downtown Brooklyn theatres, and many of the independent houses, automatically reduces the union dues, and eliminates any future assessments for old-age pension and death benefits. For example, prior to the inauguration of the new Pension and Welfare Plan, the union dues for the present quarter would have been \$42.80, as compared with \$19.25 which is now payable.

All members of the Local, retiring after January 17, 1951, will receive a weekly pension of \$30 (an increase of \$9 per week over the previous pension allowance), which is independent of any government pension or Social Security allowance he may be entitled to.

In lieu of a wage increase paid direct to Local 306 members, the aforemen-

tioned theaters have agreed to contribute 5% of the men's basic wage scale to the Local's Welfare Fund. Payments for hospitalization and medical care for the members and their wives will be made from this fund.

Since negotiations for this plan were started several months ago, it will not be affected by the recent government wage-freeze order.

• Bill Kunzmann, convention vice-president for the SMPTE, advised us that the next meeting of the Society will be held at the Hotel Statler, New York City, April 30-May 4 next. We hope that the Society will justify its bid for projectionist members by devoting at least one session to matters of interest to the projectionist craft.

• As an example of what we consider smart public relations, we point to the line followed by Local 586, Nebraska (Grand Island, Columbus, Norfolk, Hastings, and York), in effecting a more harmonious relationship between the

Local and the various civic, educational, and religious organizations in its jurisdiction. In trying to overcome the many deep-seated and unfair prejudices against labor unions, the members of Local 586 gave generously of their time and experience to these organizations whenever they put on a show. Eventually, a barrier of many-years' standing was completely broken down, and today Local 586 has their confidence and respect. Today, whenever an entertainment is planned, the Local furnishes the needed men, at regular pay.

Many thanks to Conrad Krieger, secretary of the Local, for forwarding this information—which might be emulated with profit by other Locals.

• A representative gathering turned out to witness the installation of the new officers of the 25-30 Club at the regular January meeting. Harry Mackler, president (member of New York Local 306); Edward Dougherty, vice-president (Local 384, Hudson County, N. J.), and Charles Eichhorn, trustee (Local 306), are the only new officers for 1951. Holdovers are Morris Klapholz, secretary, and Ben Stern, financial secretary-treasurer. Morris J. Rotker, past-president of the Club, presided at the ceremonies.

Among the invited guests were Admiral R. B. Tompkins, president, and Arthur Meyer, vice-president and general sales manager, International Projector Corp.; Walter E. Green, president, National Theatre Supply Co.; Allen G. Smith, New York City branch manager for NTS, and Barney Passman, chief engineer at the IPC plant in Bloomfield, N. J.

• Realizing the advantages to its younger members of a more thorough grounding in the duties of a stagehand, officials of Local 366, Westchester County, N. Y., are sponsoring a course in back-stage activities at Hunter College, New York City. This course is conducted by a member of the Local and classes are held twice weekly. Nat Storch, president, and Joe Monaco, business representative for the Local, have long cher-

ished this idea; now that it has been realized, we hope it will be tremendously successful.

- Anonymous letters, always the refuge of the cowardly and the bane of our existence. Most of us have at some time or other been the recipient of an anonymous letter or two attacking either our own or some other person's character. The writers of such letters hide behind the cloak of anonymity either because they cannot substantiate their charges or because they just haven't the guts to back them up.

As a member of one of the larger Local Unions in the Alliance, we have received many unsigned scurrilous letters, pamphlets, *etc.*, attacking the Local administration and individual members. These were generally signed "Anonymous," "The Fair Deal Committee," "Unemployed Operators Committee," "Independent Theater Operators Committee," and many other phony-sounding committee names, too numerous to mention.

It has long been our contention that such "committees" usually are non-existent—that they are merely a dodge behind which a few disgruntled members try to hide their identities. We believe that when members are dissatisfied with conditions existing in their Local and feel that they have legitimate cause for complaint, or wish to bring charges against any of its officers, they should air their grievances through the channels that are open to them and not hide behind faked committee names.

This reminds us of a comment made by Henry Ward Beecher when he received a letter which contained one word: "Fool." He said, "I have received many unsigned letters of criticism, but this is the first in which the writer signed his name but forgot to write the letter." This leaves nothing more to be said.

- The recent death of Emmett Carter, Sr., business representative of Local 587, Longview-Marshall, Texas, ended a career of many years service to the Local. Several months ago the Local awarded Carter a gold button for 37 years' loyal service.

- Wedding bells rang again for Mike Berkowitz, veteran member of New York Local 306, and his wife, Anna, when they celebrated their 50th wedding anniversary last month at the Grand Street Boys Clubhouse in New York City. Several hundred guests witnessed the "golden" ceremony, which was very beautiful and touching. Mike was as nervous as a young bridegroom; Anna was her usual composed self—naturally.

Dinner and dancing until the wee

hours wound up one of the most delightful evenings we have had in a long time. The entire affair was arranged and planned by Mike's son, Milton, chief projectionist at the Capitol Theater, famed Broadway house.

25 Years Ago—February, 1926

- The IA Executive Board unanimously elected Barney Ryan, member of Brooklyn Local No. 4, a member of the board of trustees, succeeding William Harrer, who was elected 7th IA vice-president. . . . President Bill Canavan's plan to publish a book of all IA convention proceedings from the inception of the organization to the present date was endorsed by the Executive Board. Order blanks were to be sent out to all Local Unions to determine the feasibility of such a project. . . . The nomination of George Curran, member of Boston Local 182, as a candidate for the office of sheriff of Suffolk County, Mass., was endorsed by the IA Executive Board, which urged all Local Unions in Suffolk County to get behind their fraternal brother and help

elect him to office. . . . The IA donated \$1000 to the Striking Anthracite Miners' Fund in response to an appeal by the AF of L Executive Council. . . . The General Executive Board, by unanimous vote, decided that "in the event a member be denied the privilege of working in the jurisdiction of the Local Union with which he is affiliated for any reason whatsoever, that member would not be permitted to accept employment in the jurisdiction of a sister Local Union, and his traveling privileges will be suspended until such time as his Local Union again grants him the privilege of working." . . . Malcolm Grow was expelled from membership in Local No. 638, Carbon County, Penna., for refusing to obey the official road call effective against the Park Theater in Lehighton, Penna. . . . The appeal before the IA Executive Board of Jack Seraphine, member of New York Local No. 306, against the Local's action in refusing him the privilege of running for office for membership on its Executive Board was denied. The Local alleged that Seraphine did not pay his dues within the prescribed period.

Report on IA-IP Amateur Radio Contest

By AMOS KANAGA (W6BAA)

SHORT-WAVE radio is sometimes like the fair sex: it can be gracious and generous; then again, it can be a stinker. And the IA-IP amateur radio contest week, as far as weather conditions were concerned, was a "stinker." However, on the basis of reports received to date and the many more expected, it would seem that the boys did pretty well for themselves.

The contest did not approach other such national events in terms of thousands of participants, but considering the comparatively short time in which IA national listings have been published, we did pretty well for ourselves.

Many of the boys worked their first IA contact; others had several lined up. Whenever the band opened up, especially on 10 meters, there were IA men on the air. Most of them hovered around the 28,850 frequency and passed the word along when a new IA station was worked or heard. One West Coast station worked *eight in a row*—then didn't hear any IA men for three days! After midnight, 75 meters was fairly active.

IP Listing Continues to Grow

Many new calls will be added to our list as a result of this contest, since many of our boys now look to the pages of IP for the current listing of IA radio men.

An outstanding thing about this contest, remarked by many of our fellows, was that there was not the usual haste

displayed in making contacts, as in other contests. There was more real fraternization, the boys made schedules to QSO again, and they met a lot of IA men they never knew were around on the air.

IMPORTANT: please send in a copy of your contest log, even if you only worked one IA man (and that is all several did); that station may be one that is not now on our list. When we put them all together, we'll really have something. Our list grew because every one of you took time out to let us know of another IA man who was a radio amateur. That's F'B and real spirit!

We tried our best to make the deadline for this issue, but all scores were not received in time. Fellows, we must have your log to cross-check, even if you worked only one IA brother. So, shoot it in to me pronto at 262 Westland Ave., San Mateo, Calif. Complete scores, and the contest winners, will be announced in the next (March) issue of IP—plus, of course, the very latest listing.

Many thanks—and 73.

RCA Eng. Products Personnel Changes

Theodore A. Smith, for the past five years head of sales for RCA Engineering Products, has been named assistant general manager of the department. He succeeds W. W. Watts, who is on a leave of absence for service with the NPA in Washington.

Simultaneously, A. R. Hopkins was named general sales manager of the department, while Barton Kreuzer was appointed general product manager.

Report on First Month's Phonevision Chicago Test

THE Tv topic of prime interest to film people during the past month was the report issued by Eugene F. McDonald, Jr., president of Zenith Radio, on that company's Phonevision tests over a four-week period among 300 selected families in the Chicago area. In a letter to distributors who supplied the films for the tests, McDonald declared that the operation in its first month drew 26% of the "total possible attendance." No mention was made of the obvious novelty appeal of the operation.

McDonald cited figures indicating an over-all average of 30% of the possible audience. The ten lowest-grossing features offered drew an average of 22%, and, the Zenith head declared, relatively few feature pictures produced in the last 20 years have played to that large a percentage of the possible theater audience on their first showing.

Films Two Years or More Old

Zenith is using films two or more years old, which have played out their theatrical dates.

Average attendance of those participating in the test was 3.1 times in the first week of the test, dropping to 1.9 for the second and third, and 1.7 for the fourth. Disregarding the initial week, average for the next three was 1.8 times per week per family, McDonald points out.

Projecting this against the 10 million receivers presently in use would indicate a producer's income of \$468,000,000 annually, on the basis of 50% of the \$1 fee charged in the Chicago test. To a large extent, McDonald declared, this would be supplemental to income producers would continue to receive from theaters.

Cites Results as 'Fabulous'

"These first four weeks' results on Phonevision are fabulous," McDonald emphasized, "even if you cut them in two or in four. And you must remember that this test is handicapped to some extent by the age of the pictures. All of these pictures played in theaters before the majority of our test families owned television receivers, most of them during the high-water period of theater attendance.

"We have secured phenomenal results by tapping an audience that did not see these pictures in the theater. I think it is reasonable to assume that many of these who did not buy the pictures on Phonevision, refrained because they had already seen them. Can you imagine, then, how much more startling our results would be if we were presenting new pictures that none of our families have previously seen?"

First-Time Viewing by Many

In another summary of postcard reports from Phonevision subscribers, McDonald pointed out that, except for a few great classics, four out of five are seeing the pic-

tures they purchase for the first time, "in spite of the fact that each of these pictures has long since completed its theater runs, and that some had been reissued."

"It is self-evident," the Zenith president said, "that with Phonevision we are reaching that vast segment of our population that never were regular theater-goers, and that in reaching this new audience we are adding countless millions of dollars to the value of the old features you have in your vaults. It is not beyond the realm of possibility that many of your older pictures will earn more for you on reissue by Phonevision than they have earned to date in theater showings."

Expand Use of Tv Channels

Experiments by 20th Century-Fox in theater Tv relaying the past two years indicate that cross-polarization may well lead to greater use of certain Tv channels.

These experiments, conducted in New York on the 6800-7050 mc band, indicate that programs can originate at two different points on the same channel and be received at a distribution point without cross-channel interference. While the experiments were made primarily with theater Tv in mind, the report indicates that cross-polarization will increase the use of all Tv channels.

The experiments disclosed that programs could originate at two different points, be fed to a major distribution point, then relayed to a second distribution point without interference, although only one channel was used.

AF of M Ultimatum to Tv Nets

Further difficulty for Tv broadcasters is the announcement by the American Federation of Musicians that the networks may use on Tv only those films "expressly authorized between the AF of M and producers (film) or others having interest in such film." If this ban persists, Tv stations may be in a bad way for film fare.

AF of M will permit use of film reproduction of a "live" telecast by affiliated network *at the same time show is given*, but reproduction may not be given more than one time; but in the event that it is, the following payments will be due: (1) a repeat fee must be paid to the musicians, and (2) payment must be made to the Music Performance Trust Fund equal to 5% of the "gross time charges."

Du Pont Price Tilt, Curtailment

Simultaneous with the issuance of new price list which shows increases averaging 11½% for both negative and positive motion picture film (attributed to increased labor and material costs) Du

Pont notified its customers that it was curtailing its orders by 25%. Action was taken it was explained, because of commitments to produce an increased supply of X-ray film for the armed forces and others.

Hardest hit by this curtailment of motion picture stock will be the newsreels and small laboratories, representatives of which are making strenuous efforts to have the cutback modified, at least.

Sample price increases on Du Pont stock per 1000 linear feet: 35-mm safety negative, from \$43.76 to \$49.21; release positive safety film, from \$14.80 to \$16.22.

4-Inch Lens Now Standard on All Century Projectors

Century Projector Corp. announces that the latest and most modern 4-inch diameter lens mounts are now standard equipment in Century Model C single-shutter and Model CC double-shutter projectors, on both the standard as well as the water-cooled models. This change continues the Century policy of keeping pace with the latest industry developments. Although 4-inch diameter lenses are now available only in the longer focal lengths, there are indications that the trend toward larger diameter lenses make it desirable at this time to standardize on the larger lens mounts for all projection equipment.

Confirm Nate Golden as NPA Film-Photo Director

Nathan D. Golden has been officially confirmed as director of the Motion Picture-Photo Products Division of the NPA. Golden formerly headed the Motion Picture Division of the Dept. of Commerce. During World War II he was consultant to the Production Board and to the Office of Coordinator for Inter-American Affairs. He also served as consultant to the Golden Gate International Exposition, and to the American group which considered world tariffs and trade in France in 1949.

Long, Varied Film Career

Golden has long maintained close contact with the projection groups in the film industry, following his early days as a member of IA Local 160 of Cleveland, of which organization he is a life member. He received the first gold medal award of the Projection Advisory Council.

A veteran of World War I, Golden entered U. S. service in 1926. He is a graduate of Washington College of Law, American University; past commander of the D. C., V. of F. Wars as well as of the Legion Post, National Press Club; fellow of the SMPTE, member of Projection Advisory Council, and chairman of the Heart Committee, Variety Clubs.

NEWS PROJECTIONS

WHOLLY aside from present construction curbs, theater building should be stopped completely for five years as a "breather" and to check over-seating which is rampant, says Abram Myers, general counsel for Allied States exhib group. . . . Paramount plans to put 52 features in work within the next 24 months, Tv notwithstanding. . . . Theater construction and alterations in Canada last year cost \$6 million, bringing the past five-years' total to over \$33 millions. . . . Loew's has been granted extra time to March 31 next to file its exhibition-production divorcement plan with the Dept. of Justice. . . . More than 97% of U. S. theaters sell candy, 95% sell popcorn, and 79% sell soft drinks. Some 86% have refreshment stands, while 47% use coin machines, meaning some have both. . . . Technicolor announced that it plans to process 103 forthcoming productions either set for release, in production, or in preparation. Biggest Technicolor program ever, probably in response to insistent exhibitor demand.

National exhibitor groups still fearful that the present high 20% ticket tax will be boosted during current defense emergency; although in-the-know Washington sources insist there will be no upward tilt. . . . National Collegiate Athletic Assoc. Tv committee came out flatfootedly for a ban on home telecasts of football games, citing a box-office drop this past season. Committee would like to make an exclusive deal direct with theaters, if enough houses would install Tv units. . . . Paramount has announced the purchase for retirement of 251,000 shares of its own common stock on the N. Y. Stock Exchange, at the pegged price of \$21.50 a share. . . . RKO Theaters in New York area have concluded a 13-week deal with NBC Tv outlet to promote former's attractions and "Let's Go Out to The Movies" campaign. First such deal by a major circuit. . . . Permission granted to RCA to appeal recent Chicago court decision anent color Tv (which favored CBS non-compatible system approved by the FCC) is largely academic in view of manufacturing restrictions which will effectively bar color Tv progress for several years. . . . Better pictures plus increased defense plant earnings are cited for recent upswing in box-office take, especially in Mid-West and South. . . . Quote from Julian Brylawski of Metropolitan Theater Owners of Washington, D. C., on possible theater Tv installations: "We cannot sell what they (standard Tv programs) are giving away, no matter how



Your patrons will notice the difference! Super Snaplites give you Sharper Pictures, More Illumination, Greater Contrast and Definition.

For the Best in Projection use Super Snaplites . . . the only Projection Lenses to give you a true speed of f/1.9 in every focal length up to 7 inches.



Clear
Crisp Pictures
with
SUPER SNAPLITE
f/1.9
PROJECTION LENSES

Ask for Bulletins
207 and 209

KOLLMORGEN

2 Franklin Avenue
Brooklyn 11, New York

Optical



CORPORATION

"YOU GET MORE LIGHT WITH SUPER SNAPLITE"

inferior their product is." . . . Schine Theaters, loser in a Government anti-trust suit, has put 28 houses in New York, Maryland, Ohio and Kentucky on the block, ranging from the 394-seat Corbin, Ky., leasehold for \$7,500 to the 1381-seat Madison in Rochester, N. Y., for \$550,000.

Arctic Blanch Screen Surface

High reflectivity and a near-perfect diffusion of light over the entire surface are the

primary requirements for an efficient screen in a drive-in theater. An additional consideration is the ability of the screen surfacing medium to withstand the rigors of all types of weather through a long operating season.

This is the opinion of Ken Caldwell, president of National Theater Screen Refinishing Co., Buffalo, N. Y., and a member of IA Local 233, following an intensive survey of scores of drive-in screen surfaces.

Ordinary flat paint will enable a high degree of reflectivity, says Ken, but it contains little oil and thus cannot withstand weather abuse. The trick may be accomplished, how-

ever, by the proper combining of certain materials which fulfill all requirements. Ken asserts he has turned this trick with his Arctic Blanch refinishing paint, already used in several hundred drive-ins.

Arctic Blanch finish permits high reflectivity, fine diffusion of light without glaring "hot spots," and stands up under all weather conditions. Full details of this product may be had by writing direct to NTSR Co., at 129 Zenner St., Buffalo 11, N. Y.

It's good showmanship to keep the HEART of your theatre running smoothly

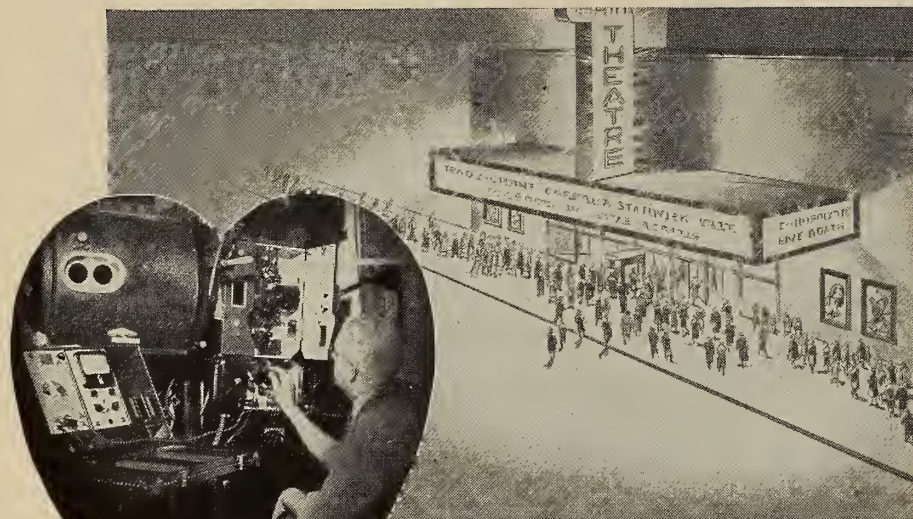

PROJECTION SOUND
... AND RCA SERVICE

it costs so little to protect so much

The advantages of RCA Service are yours at a cost so low, a few admissions daily pay for it. Write for free folder—"Performance Security."



Every exhibitor, whether he operates a first-run downtown theatre, a neighborhood or small town house, must constantly maintain a smooth-running show to create a steady and reliable following of patrons. It's smart showmanship to present attractions at their very best.

RCA Service, by protecting the projection room equipment—the heart of the theatre—makes sure it operates smoothly . . . at top efficiency. RCA Service technicians are skilled in the systematic point-to-point checkup and maintenance of all types of projection and sound equipment regardless of make. RCA Service Plans combine expert technical assistance with comprehensive parts and repair provisions for motion picture and theatre TV equipments.



RCA SERVICE COMPANY, INC.
A RADIO CORPORATION of AMERICA SUBSIDIARY
CAMDEN, NEW JERSEY

IA ELECTIONS

LOCAL 236, BIRMINGHAM, ALA.

F. E. Walker, *pres.*; E. E. Jones, *vice-pres.*; J. Frank Mankin, *sec.*; C. M. Trent, *treas.*; R. A. Root, Sr., *bus. rep.*; J. N. Cason, *sgt.-at-arms*; J. C. Harper, Jr., T. W. Wall, W. H. Neal, Jr., *trustees*.

LOCAL 291, GRAND RAPIDS, MICH.

C. R. Bright, *pres.*; C. M. Breas, *1st vice-pres.*; A. J. Prus, *2nd vice-pres.*; C. W. Gillette, *3rd vice-pres.*; D. M. Landon, *rec.-sec.*; J. O. Bogardus, *sec.-treas.*; S. L. Hattis, *bus. rep.*; J. J. Korzak, *sgt.-at-arms*; F. A. Arndt, W. G. Emaus, W. J. Sowa, *trustees*; J. O. Bogardus, W. A. Barr, A. E. Wick, *exam. board*; J. J. Korzak, S. M. Kant, A. C. Jensen, *del. Fed. Labor Convention*.

LOCAL 310, ATLANTIC CITY, N. J.

William Clendening, *pres.*; Richard McSweeney, *vice-pres.*; Vincent J. Sheeran, *rec.-sec.*; William Monroe, *fin.-sec.*; August Hilton, *bus. rep.*; William Oliver, *sgt.-at-arms*; William Shapiro, Joseph Jacoby, Richard DeHaven, *trustees*; Walter Seeley, Frank Bernato, *exec. board*; Frederick Dodd, *del. CLU*.

LOCAL 407, SAN ANTONIO, TEX.

Genaro G. Garcia, *pres.*; Joe P. Cuevas, *vice-pres.*; Horace E. Blanton, *rec.-sec.*; Henry L. Villapadierna, *sec.-treas.*; Ernest L. Roberson, *bus. rep.*; Phillip N. Wehrmann, Manuel Ayala, *members at large*.

LOCAL 458, PORTLAND, MAINE

Chelsea A. Waldron, *pres.*; Maurice Eaton, *vice-pres.*; Paul S. Davis, *sec.*; George E. Francis, *treas.*; Frank X. Smith, *bus. rep.*; John H. Decker, *sgt.-at-arms*; William Wilkinson, *exec. board*.

LOCAL 599, FRESNO, CALIF.

Fenton Quimby, *pres.*; Paul Ausbrook, *1st vice-pres.*; William Wardlaw, *2nd vice-pres.*; Frank Letlow, *3rd vice-pres.*; Fred Carbine, *rec.-sec.*; Ottie Junkins, *fin.-sec.*; Dallas Page, *bus. rep.*; Charles Busby, *sgt.-at-arms*; William Vogel, *trustee*; Grover Miller, *wage committee*; D. Page, *del.* and F. Carbine, *alt. del. State Federation of Labor*; Jerry Viele, *del. Labor Council*.

LOCAL 735, MT. CLEMENS, MICH.

Fritz Devantier, *pres.*; Bert Penzien, *vice-pres.*; Earl Natzel, *sec.*; George Konath, *treas.*; Roy Suckling, *bus. rep.*; George V. Hemp, *sgt.-at-arms*; F. Devantier, *deputy-at-large*; and B. Penzien, *alternate*.

Buy U. S. Savings Bonds

CATHODE-RAY TUBE DATA

(Continued from page 19)

would be exerted; if the force is applied to move a charge, the motion of the charge would be along such a line. Hence the physicist's artifice of *lines of force* as the pattern of the electrostatic field. This makes sense and is a very convenient method of presentation because it does inform about the *condition* of the space.

Admittedly, such a direction line alone is not all the information about the forces present within a field, because it lacks data relative to the *magnitude* of the

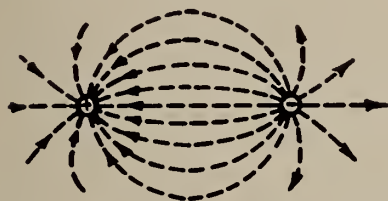

FIG. 5. Representation of the electrostatic field between two unlike charges.

force. However, if we are interested only in the general pattern of the field, and not in the *exact constants* of a *specific* field, we can do without the magnitudes of force at different points in the field.

Such actually is the case: the pattern of the electrostatic field between two unlike and between two like charges is of much more value to us than the *actual distribution* of forces. This is so because our object now is the presentation of information about the *purpose* of the lines of force and their *behavior*, rather than the actual magnitudes. So the stage is set for the picturization of an electrostatic field and lines of force.

The Field Between Unlike Charges

In Fig. 5 is shown the electrostatic field between two unlike charges. These need not be two elemental charges of unlike sign; they could just as readily be *accumulations* of unlike charges—all of *one* sign in one group distributed around the surface of a sphere, and all of *opposite* sign similarly distributed on the surface of another sphere. The general nature of the field will be the same for both of these conditions, although it must be said that such a pattern will not hold for all configurations of the body which mounts the charges.

When the shape of the field sources is spherical and the charges are unlike,

Kodak's 39th Annual Wage Dividend

Eastman Kodak directors have voted an employe wage dividend of an estimated \$18,000,000 for about 45,000 Kodak men and women in the United States. Eligible employes will receive \$27.50 for each \$1,000 earned at Kodak during 1946 through 1950. To be paid March 9, 1951, the wage dividend will be the 39th payment under the plan.

the pattern of the field is as shown in Fig. 5. A change in shape of a group of charges will cause a different type of field. Meanwhile, it is possible to develop information about the behavior of the lines of force using this elemental field pattern, because the *manner* in which the lines of force *behave* is fundamental and not subject to specific configuration either of the field source or the field itself.

Many interesting observations may be

made about such a field in terms of the lines of force. For example, some lines of force are shown joining the two unlike charges which we shall assume to be separated by a certain distance. The actual dimension of this distance is unimportant. Other lines are shown incomplete. This, however, is purely a matter of limitations in illustrating, because every line of force between two charges join these two charges. Therefore, if you can visualize such a thing, the lines of

MAN ALIVE what a PROJECTOR

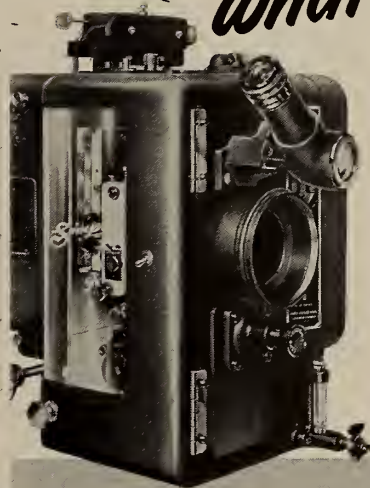

That's high tribute
from you men "behind
the show."
That's what
projectionists
everywhere are saying
about the...



EVERYTHING FOR THE
PROJECTION ROOM

NATIONAL
THEATRE SUPPLY
Division of National Simplex-Biogrowth, Inc.

Simplex
REG. U.S. PAT. OFF.

X·L

The Projectionists PROJECTOR

NEVER HAS
Economy
BEEN SO
ESSENTIAL AS NOW!

THERE IS A LORRAINE CARBON TAILORED FOR
YOUR SPECIFIC PROJECTION REQUIREMENT
Send necessary projection equipment
data to guide us in recommending the
Lorraine Carbons that will do your
theatre or drive-in projection job better
and More Economically.

SLOW BURNING
SAVINGS IN POWER CONSUMPTION
SAVINGS IN MAINTENANCE

ECONOMIZE

WITH *Lorraine*
Carbons

Lorraine CARBONS, INC., BOONTON, N. J.

force issue from each charge in all directions and join the charges.

Spacing of Lines of Force

The two charges in Fig. 5 are shown relatively close to each other. Such, however, need not be the case: the unlike charges can be far apart without in any way changing the condition that lines of force from a negative charge will terminate on a positive charge, or *vice versa*. Theoretically, the amount of separation

of the unlike charges is of no consequence.

Then there is the matter of the space between the lines of force. This, too, is a limitation in illustrating. Actually there is no space between them; all the area, in all directions, is filled with lines of force. In drawing the field, we select certain lines only as being representative, and show them.

As to the direction of the field, shown by the arrowheads, it is the direction in

which the force would be exerted *along the line of force* in accordance with a certain convention. This requires some elaboration.

Two conventions exist for the direction of an electrostatic field. One frequently-used convention assumes such direction of the field as would be indicated if a test charge of positive polarity were placed into the field. The other convention, used herein, assumes such direction of the field as would be indicated if the test charge placed into the field were of negative sign. Our preference for this convention is based on the fact that the electrostatic fields in the cathode-ray tube act on the electron, which has a negative charge; therefore, we avoid confusion by considering that direction which conforms most closely to the final analysis of cathode-ray operation.

Accordingly, the direction-arrows point away from the negative charge and toward the positive charge, and show the direction in which an electron would move when under the influence of the field. In this connection, we might mention that the field shown in Fig. 5 does not require the negative charge to advance to the positive charge. It is possible to imagine these two charges as being fixed in their respective positions, in which case conditions would remain constant and an electrostatic field of a certain direction, which *could* cause a certain motion on the part of an electron placed within the field, would be effective.

Behavior of the Lines of Force

Continuing with our discussion of the field between two unlike charges, as shown in Fig. 5, several very important comments must yet be made. Perhaps, from the viewpoint of utility, these are more important than any made so far.

We mentioned earlier that the effect of the field was the application of forces to those things which were susceptible to such forces. Let us consider the basic law which states that unlike charges are attracted to each other. Such attraction often involves physical motion and, according to our convention, it would be a motion of the electron.

Is such motion a function of the charges themselves, that is, their presence? Or, put differently, do the charges move of their own volition because they are of unlike polarity?

According to the theory, the answer is negative. It is true that the polarity of the charges determines the field, but the effect of the field as interpreted in the motion of the charges is due to the *behavior* of the lines of force. As stated earlier, these lines are aids to visualizing what actually does happen, and have no independent existence outside of the imagination. Since they are imaginary,

ANSWER TO YOUR TECHNICAL PROBLEMS...



The
Altec
Service
Man

*The Altec
Service Man and
the organization
behind him*



161 Sixth Avenue,
New York 13, N. Y.

PROTECTING THE THEATRE—FIRST PLACE IN ENTERTAINMENT

WENZEL PROJECTOR CO.

Manufacturers of Many Types of

FILM REWINDERS

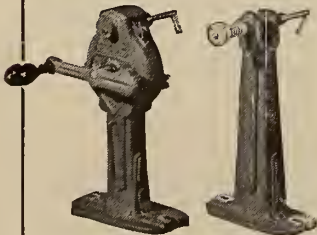

8 M/M
16 M/M
35 M/M
Film

Write for
Illustrated
Brochure

WENZEL PROJECTOR CO.

2505-19 S. State St.

Chicago 16, Ill.

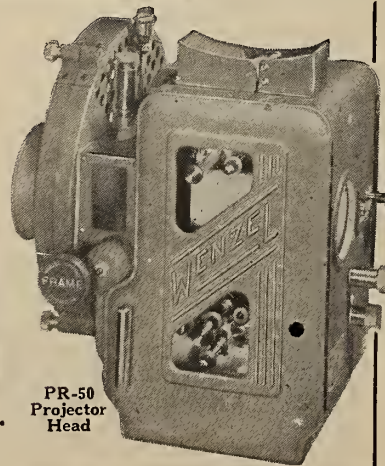

PR-50
Projector
Head

we may assign any properties we choose to help describe what actually happens.

One such property is that of lengthwise contraction: we assume that lines of

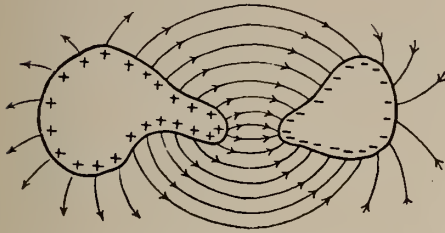

FIG. 6. Distribution of electrostatic lines of force around an irregularly-shaped body.

force tend to shrink along their length. For example, a line extending from a positive charge to an electron, in shrinking, would draw the electron toward the charge. If the electrons were carried further away from the positive charge, the line of force would be stretched; a mechanical force would be required to do this. Given the opportunity, as determined by the mobility of the charges, the electric lines of force between the two charges will bring the charges together so as to satisfy the fundamental condition of minimum length of the line of force.

Harnessing Energy

It is because of this, as well as a few other conditions, that a comparison is made between the behavior of such lines of force and that of stretched rubber bands. Of course, there are limits to the application of this analogy, but it is a reasonable one when we visualize the line of force as possessing energy which

can be put to use, just as the stretched rubber band possesses energy which can be put to work. Most certainly the tendency of the stretched rubber band is to shorten itself, and in so doing, to do work.

The same can be said about the electric line of force. Given the opportunity to contract, the energy present along the line of force will be transformed into other forms of energy—perhaps kinetic energy applied to the electron so as to get it to move, or/and, of course, into heat. At any rate, the energy in the field, distributed along the lines of force, is capable of doing work during the time that the lines of force contract.

Another property of the lines of force is that lines active in the same direction appear to repel one another laterally. This accounts for the curvature of the lines of force which join two charges at points other than on the straight-line axis between the charges.

Effect of 'Repulsive Force'

The line of force along the axis is straight because the amount of repulsion, from other lines laterally positioned, is the same on all sides—in other words, the forces are symmetrical. However, at distances from the axis the lines of force curve outward because of the greater amount of repulsive force originating from the direction of the axis and the less repulsive force originating from the outer side of the force line. Nevertheless, spaces still do not exist between the lines of force: the lines simply curve outward instead of being straight.

This property of the lines of force be-

tween two unlike charges may not have much bearing upon the behavior of such charges. Being subject to attractive forces, it is the shortening of the line of force along its length which is the paramount action. However, the lateral repulsion between the lines of force with like direction is very important in the behavior of like charges.

[NOTE: A comprehensive review of this series of articles over-all will be available to those readers who preserve the issues in which each installment appears, beginning with IP for Dec., 1950, and running in consecutive issues hereafter.—ED.]

"ARTIC BLANCH"
Snow White
THE DEPENDABLE SCREEN COATING
for
DRIVE-IN THEATRES
NATIONAL THEATRE SCREEN
REFINISHING CO.
129 ZENNER ST. BUFFALO 11, N. Y.



"SO YOU WANT MORE FOR YOUR MONEY... YOU SAY YOU AIN'T SATISFIED" ... TELL YOU WHAT WE'RE DOING!

Motiograph Hi-Power Motor-Generators—the most dependable source of direct current for arc lamp service are offered at an unheard-of low price . . . below that of any other generator, and even many rectifiers.

Highest overall efficiency. Lowest maintenance cost. Models for 40/70 ampere and 65/125 ampere arc lamps.

Service available through carefully selected Motiograph dealers and in over 100 cities in 44 states and 7 Canadian provinces and in 45 foreign cities.

M O T I O G R A P H , I N C
"America's Oldest Manufacturer of Projection Equipment"
4431 WEST LAKE STREET CHICAGO 24, ILLINOIS



OPTICS OF ARCLAMPS

(Continued from page 6)

mum waste of light at the aperture spot.

The writer strongly suspects that an apospherical mirror designed for use with the ordinary H-I arc will be elliptical, like the orthodox mirror responsible for our oft-voiced complaints. There is, however, a very important difference.

Compared with the usual type of elliptical mirror, the curvature of the apospherical mirror will be "exaggerated," i.e., the central zones will have a greater curvature than the regular type of elliptical mirror, and the outer zones will have less curvature.

An optical designer will at once recognize this mirror as an elliptical mirror having a greater "eccentricity" and a longer "major axis" than the orthodox lamp mirror. From still another point

of view, it may be said that our apospherical mirror is a "parabolized" elliptical mirror, even though it is not a true parabolic mirror.

The success we hope to obtain with the apospherical mirror depends in a very large measure on the exact relation of arc-crater and aperture positions to the actual geometric foci of the ellipse. We will now break the rules of orthodox mirror optics and place the positive crater slightly beyond the focus which lies nearest the mirror, and permit the distant focus to fall where it may on the far side of the aperture. And no less important are the diameter of the positive crater and the luminosity gradient across its face. Both factors must be taken into account by the optical designer.

The calculations required in the designing of such a mirror are plenty tough—but not too tough for a competent optical designer. However, lacking this

high degree of mathematical wizardry, we can do as well by the trial-and-error method, that is, making a number of apospherical mirrors of different degrees of approximately correct ellipticity and selecting the one which gives the screen results we desire.

The ideal apospherical mirror will produce a "spot" very much like that shown in C of Fig. 4; and the side-to-center distribution of light on the screen will lie between 90 and 95%, giving the appearance of perfect uniformity. Pleased as we may well be with this improvement, we soon discover other good reasons for praising our apospherical mirror.

Despite the fact that the crater of the positive carbon lies a trifle from the mirror than is the case with the ordinary lamp set-up, reducing very slightly the total amount of light picked up by the mirror, we find that the total light flux pouring from the lens of the projector is no less than with the most efficient orthodox elliptical mirror. This is because we can now employ a smaller, more sharply defined spot than before. The smaller the amount of light wasted on the cooling plate, the brighter will be the screen.

Uniform Screen Illumination

And this is not all! Because the "hot spot" has now been completely eliminated from the screen, minute accidental wanderings in the position of the positive crater do not show up on the screen—the crater would have to be away out of line to darken one side or corner of the screen. Yes, the screen is flooded by smooth, bright illumination all over its immense surface. No chance at all for one side of the picture to become brighter or dimmer than the other side due to slight movements of the positive carbon! Moreover, uniform illumination of the film in the aperture decreases the likelihood of embossing or blistering the center of the frames when high-powered arcs are used.

The outstanding peculiarity of the apospherical mirror in its proper application is its inability to form a true optical image of the "object" (arc crater). A pinpoint light source, for example, is focussed at the aperture as a ring of light with a comparatively dark center. A spherical mirror would give a fuzzy blob of light under these conditions; and an orthodox elliptical mirror would give a true point image. The apospherical mirror, therefore, distorts the image of the bright-centered H-I crater in such a way that a uniformly illuminated disc of light is formed at the aperture.

Readers of these lines may suspect that some degree of antispherical aberration can be produced by bringing a



This is the **CARBON SAVER**
Everyone Is Talking About!

THE CRON-O-MATIC FULLY AUTOMATIC CARBON SAVER

It's the big talk because here at last is a carbon saver THAT REALLY WORKS! It uses up carbons of all sizes with no preparation of the stubs being required. You simply insert the stub in the holder and forget it. It in no way interferes with the regular operation of the lamp. Take advantage of this new and easy way to save real money. Install a Cron-O-Matic and CUT YOUR CARBON COSTS 25%.

Adaptable to Ashcraft "D", Brenkert-Enarc, Peerless Magnarc and Strong Mogul lamps.

Only \$52.50 and pays for itself in a short time . . . then goes on to make money for you in the future.

Sold by most leading theatre equipment dealers. If your dealer cannot supply you order from,

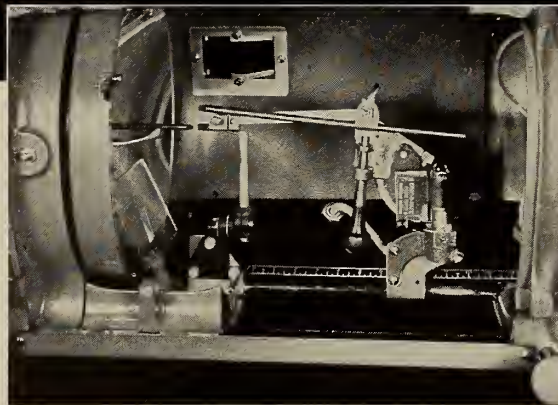

PAYNE PRODUCTS COMPANY

Cron-O-Matic Division

2454 W. Stadium Blvd. Ann Arbor, Michigan

() Please send free literature on Cron-O-Matic Carbon Saver.

() Please ship Cron-O-Matic Carbon Saver

() C.O.D. including postage, () Remittance herewith,

() Send name of nearest dealer.

NAME

THEATRE

STREET

CITY & STATE

Dealer Inquiries Invited

CLAYTON BALL-BEARING EVEN TENSION TAKE-UPS

For all projectors and sound equipments

All take-ups wind film on 2, 4 and 5 inch hub reels.

Silent Chain Drives

THE CLAYTON REWINDER

For perfect rewinding on 2000-foot reels.

CLAYTON PRODUCTS CO.

31-45 Tibbett Avenue

New York 63, N. Y.

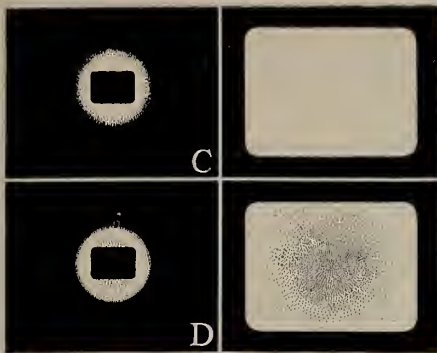

FIG. 4. The "spot" and resulting screen illumination produced by C a special elliptical mirror designed to produce the opposite of spherical aberration, and D a parabolic mirror used without a condensing lens. Only a mirror capable of counteracting the "hot spot" of the H-I crater can give the uniform screen illumination shown in C.

standard elliptical mirror (or the entire lamphouse) closer to the projection head, thus shortening the working distance. That is absolutely true. But because the ellipticity of the mirror remains unchanged, the amount of antispherical aberration which can be brought about in this way without producing undesirable side-effects is very limited.

These undesirable effects are decreased efficiency of the mirror, discoloration of the light, and a shadow spot in the middle of the screen. Besides, unlike the old L-I mirror lamps, which were comparatively small in overall size, and which were provided with sliding mirror supports, most H-I lamps, both rotating-positive and simplified, are constructed

in such a way that optical corrections are impossible with them.

Side-to-Center Distribution

The foregoing paragraph may serve to explain why the writer has been unable to obtain anything better than an 80% side-to-center distribution with commercial H-I arc-lamps. Many of these lamps permit nothing better than 65 or 70% distribution, no matter how carefully they are set up.

Turning once more to Fig. 4: the panel marked D shows what happens if the eccentricity of the aospherical mirror is made too great. The antispherical aberration is so pronounced that the edges of the picture are actually brighter than the center area—a very undesirable condition.

The data from which panel D was sketched were obtained from man experimental set-up utilizing a parabolic mirror. A parabola is a geometric figure obtained by slicing through a cone, keeping the cut parallel to one of the sides of the cone. Unlike an ellipse, a parabola has one end open, and the sides never meet no matter how far they are extended.

A parabola has only one focus. When a point-source of light is placed at this focus, the rays are sent out from the mirror parallel to one another, a situation which permits them to snap their fingers at the inverse-square law.

A beam composed of truly parallel rays never weakens in intensity, not even if it travels a billion miles. In actual practice there is no such thing as a true point-source of light, because

even the very smallest things in nature—protons, electron-waves, and single waves of gamma radiation—have appreciable size. Nevertheless, very small light sources used with parabolic mirrors produce beams which travel quite a distance before they finally weaken and give up. Examples are navy searchlights, airfield beacons, and locomotive headlights. The reflector of an automobile headlight is a parabolic mirror of short focal length.

If the source of light is placed slightly beyond the focus of the parabolic mirror, a "spot" is obtained, as in panel D of Fig. 4.

In motion picture work, the parabolic mirror was used in one of the Motiograph

THE OPERATORS' FAVORITE!



GoldE's Automatic Enclosed Rewind Always Works! Silent, safe, U.L. approved! Eliminates fire hazard. Positive friction... can't clinch film. Tilt-back case... reels can't fly off. Microswitch safety cut-off... when door opens or film breaks, motor stops!

AT BETTER THEATRE SUPPLY DEALERS
GOLDE MANUFACTURING COMPANY
1222-P. WEST MADISON STREET • CHICAGO 7, ILLINOIS

ONLY *Century* PROJECTORS HAVE EVERYTHING



4-inch diam. lens mount

Water-cooled apertures

Oil-less Bearings

CENTURY'S high-efficiency projector with the NEW 4-inch diam. lens provides pictures of increased brightness and appeal—for even the largest drive-in screens.

CENTURY'S water-cooled aperture gives as much light with a 90 ampere arc as other projectors using a 180 ampere arc and heat filters!—Reduce power cost—Get sharper pictures—Save film.

CENTURY'S sealed, oil-less bearings and glass-hard gears reduce maintenance costs. No oil sprays or baths to mess up film or projection room.

You can SEE and HEAR the difference!

CENTURY PROJECTION AND SOUND SYSTEMS
See your dealer or write for information

CENTURY PROJECTOR CORPORATION *Century*

New York, N. Y.

EFFICIENT • DEPENDABLE

RECTIFIERS

for Every Type Projection Lamp



2-Tube
4-Tube
6-Tube

Single and Three Phase Models for

- Rotating Feed Angular Trim High Intensity
- Copper Coated Coaxial High Intensity
- 1 K.W. High Intensity
- Low Intensity

Smooth Output Current • Long Life
Low Operating Temperature
Flexibility in Control

Write today for literature or free demonstration.

THE STRONG ELECTRIC CORP.

31 CITY PARK AVENUE
TOLEDO 2, OHIO

PROJECTION LAMPS • RECTIFIERS
SPOTLIGHTS • REFLECTORS

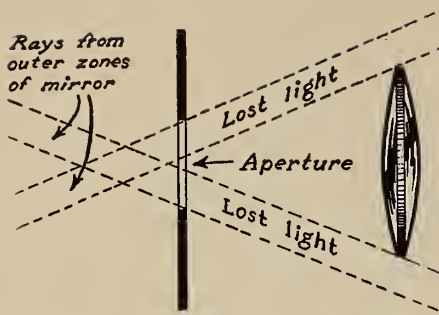

FIG. 5. Much of the light focused on the film by the outer zones of a large lamphouse mirror is lost because it overshoots the lens. The result is "hot-spot" projection and overheating of the aperture plate and film.

L-I lamps. The mirror threw the light forward in the light-cone of the lamp-house. The condenser converged them to a brilliant spot at the aperture.

Lamp manufacturers may well reconsider some of the "flexible" features of the older projector lamps—a smaller housing and a moveable mirror support. Most of the latest lamps, even those rated at 150 amperes, are too big in physical size. It is quite a problem to squeeze a pair of them into a small projection room. The same optical efficiency can be obtained with smaller mirrors located closer to the projector head. Of course, they must not be so small that they overheat, but there is little danger of that. Compared with some of the old-fashioned LII vertical arcs which blazed away with awesome fury at 130 amps, the most powerful modern H-I arcs are cool indeed.

Greater optical flexibility in the design of H-I lamps has much to commend it to manufacturers. By making simple predetermined adjustments in mirror and burner distances, various mirrors could be made available to supply the degree of light distribution most satisfactory to each particular projection installation.

A side-to-center distribution of 60% may be good enough for some drive-ins; 80% for other drive-ins and for extremely large indoor theatres, and 95% for small and medium-size indoor theatres and other operations demanding the best.

As We Were Saying . . .

Despite our numerous critics, we repeat: the appearance of uniform screen illumination cannot be obtained without uniformly illuminating the screen. No side-to-center distribution under the optimum 95% is acceptable where projection of the highest quality is desired.

It has been pointed out time and again in IP that the distribution of light on the screen is affected by the projection lens as well as by the optics of the arc lamp. A projection lens too small in diameter fails to intercept much of the light passing close by the edges of the aperture, and thus produces an objec-

tionable fadeaway of light at the edges of the projected picture. All things being relative, it stands to reason that too large a lamp mirror produces the same bad effect.

Lenses having speeds of F:1.9 or F:2.0 are about as large as is practical, both from the standpoint of the optical designer and that of the projector manufacturer. Lenses of even these rapid speeds, however, are actually *over-matched* by the optics of almost every arclamp on the market.

A mirror rated at F:1.9, for example, represents an actual optical speed of approximately F:0.34. Calculation shows that it would require a lens-speed of F:1.36 to match such a mirror, if the projection lens has a focal length of 4 inches. Lenses as rapid as F:1.36 simply are not available.

Effect of Oversize Mirrors

Figure 5 shows how oversize mirrors heat up the aperture plate and the film without producing an equivalent increase in screen illumination. Much of the light coming from the edge zones of the mirror does not even hit the lens! But even though the rays from the top edge of the mirror and passing through the lower part of the aperture miss the lens, the rays from the same edge of the mirror passing through higher areas of the aperture do succeed in striking some part of the lens. The net effect is a hot-spot at the center of the screen and a fadeaway at the edges.

The apospherical mirror described

previously, however, would go far to minimize this undesirable characteristic of large mirrors, and actually increase their efficiency as regards total screen lumens.

With such a mirror, the rays thrown forward at the top edge of the mirror are concentrated at the top of the aperture; rays from the bottom of the mirror at the bottom of the aperture. The "crossover" of rays shown in Fig. 5 is thus shifted toward the lens, minimizing the "spread" of the light, enabling the lens to receive much more of the light which passes through the film.

Lamps having extremely large mirrors working at comparatively short distances from the projector aperture may thus be expected to give hot-spot effects. Such lamps, however, actually do produce an extremely large volume of light for the amount of current burned; and their use is practically mandatory for drive-in theatres. In fact, some of the larger drive-ins could not well exist without such lamps.

The foregoing remarks, therefore, are applicable only to lamps designed expressly for use in small and medium-size indoor theatres, where light-distribution on the screen of better than 60 to 80% is desired.

[NOTE: The Ventarc mirror described in an article beginning on p. 24 of the December, 1950, issue of IP performs the same optical job as the "apospherical" mirror described in this article. It remains to be seen, however, which of the two mirrors works most efficiently, and with a minimum of edge-coloration of the picture.]

How Many?

Was this copy dog-eared when it came to you? How many men read it ahead of you?

You would receive a clean, fresh copy if you had a personal subscription—and you wouldn't have to wait—you would be first to read it.

Use coupon below.

INTERNATIONAL PROJECTIONIST.

19 West 44 St., New York 18, N. Y.

Enter my subscription for 1 year—12 issues—\$2.50
 2 years—24 issues—\$4.00

Foreign and Canada: Add 50c per year.

Name

Address

City State

"The bonds Lila and I bought for our country's defense helped us to own our own home!"

HOW U. S. SAVINGS BONDS PAID OFF FOR SELDEN AND LILA ROBINSON OF DENVER, COLORADO

"Bond saving made it possible for me to become a home owner," says engineer-sportsman Selden Robinson, "then helped me to improve on my original investment through the purchase of a better home. My story should encourage every man who dreams of a house of his own."

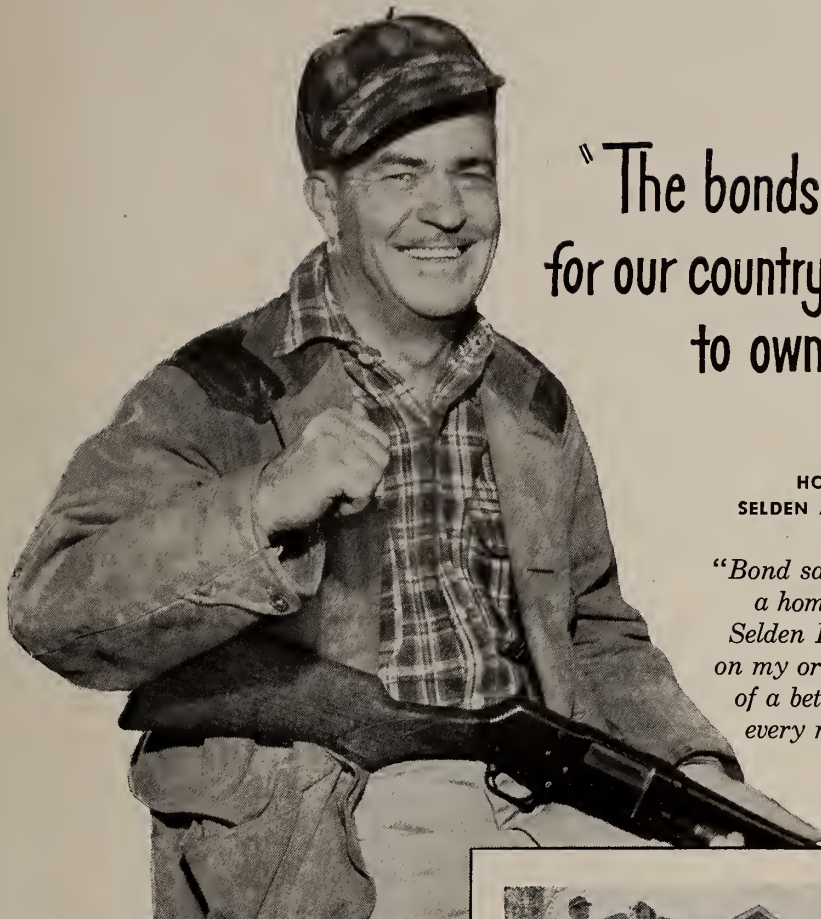

"We started our bond buying program before the war, purchasing two \$18.75 bonds a month through the Payroll Savings Plan at the Stearns-Roger Manufacturing Co. When war came, we gave up our dream home for the duration and were glad our bonds went for our country's victory."



"Bonds paid \$2800 down on a house in 1945. They provided \$500 toward a new car. And this year when we traded our first house for a new brick one, bonds paid the difference. We had the money only because of our systematic bond buying program."



"We've saved \$4,000, and now we're buying bonds toward a college education for our two daughters, Emily, 15 and Carol, 8. There's no surer savings program than Payroll Savings and U. S. Savings Bonds which are backed by the greatest nation on earth!"

The Robinsons' story can be your story, too!

FOR YOUR SECURITY, AND YOUR COUNTRY'S TOO, SAVE NOW— THROUGH REGULAR PURCHASE OF U. S. SAVINGS BONDS!



You can make your dream come true, too—just as the Robinsons did. It's easy! Just start *now* with these three simple steps:

1. Make one big decision—to put saving *first*, before you even touch your income.
2. Decide to save a regular amount *systematically*, week after week or month after month. Even a small sum, saved on a systematic basis, becomes a large sum in an amazingly short time!
3. Start saving automatically by

signing up *today* in the Payroll Savings Plan where you work or the Bond-A-Month Plan where you bank. You may save as little as \$1.25 a week or as much as \$375 a month. If you can set aside just \$7.50 weekly, in 10 years you'll have bonds and interest worth \$4,329.02 cash!

You'll be providing security not only for yourself and your family but for the free way of life that's so important to us all. And in far less time than you think, you'll have turned your dreams into reality, just as Selden and Lila Robinson have done.

The "S.S. Independence"

Newest Queen of the Seas

INSTALLS

Simplex
REG. U.S. PAT. OFF.

**PROJECTION and
SOUND SYSTEM**



THE AMERICAN EXPORT LINES, owners of the S. S. Independence, know that the most modern of ships must have the newest and most modern appointments.

That's why they chose to install Simplex — the finest in sound and projection equipment.

For here was the system designed to insure the passengers of the luxurious S. S. Independence, motion picture entertainment at its best in their floating theaters.

THEATRE SUPPLY COMPANY, INC. — 125 W. 47th ST. — NEW YORK, N. Y.

MANUFACTURED BY INTERNATIONAL PROJECTOR CORPORATION • DISTRIBUTED BY NATIONAL THEATRE SUPPLY

195321

PROJECTIONIST

INTERNATIONAL
MAR 21 1951



THE LIBRARY OF
CONGRESS
SERIAL RECORD
MAR 30 1951
Copy

MARCH 1951

VOLUME 26 • NUMBER 3

30c A COPY • \$2.50 A YEAR

7 out of 10
choose

Peerless

MAGNARC
TRADE MARK REG

1-KW TO 70 AMPS

"HY-AX" ARC MAGNET

"HY-LUMEN" REFLECTOR

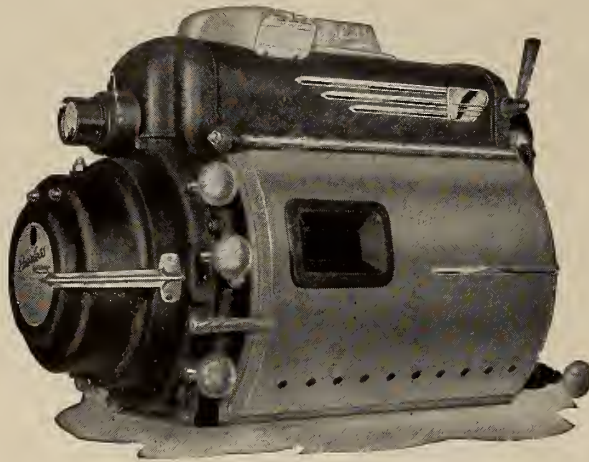

More light at 40 to 70 amperes than ever thought possible. . . . Equals and excels any reflector lamp to 85 amperes, whether they be unapproved water-cooled or resurrected "Hi-Lows". . . . Highest ratio of honest screen lumens per arc watt At 70 amperes, using an accurated Glass Hy-Lumen Reflector*, with a projector having an efficient revolving shutter, it develops the maximum screen brilliance that can be used without a heat filter at no risk of film damage. . . . Operating costs under these conditions are far below that of 85-ampere lamps.

Magnarc Lamps assure 80% side-to-center (SMPE Standard) screen light distribution, not a deceptive 60% or "Hot Center." . . . They are all Und. Lab., Inc. listed. . . . They are not insurance hazards. . . . They are and have been for years "The First Choice" of large and small theatres, drive-ins, and the motion picture industry.

* Similar results are not guaranteed if all-metal reflectors are used

"FIRST WITH THE FINEST"

120-180 AMPERES



Peerless
HY-CANDESCENT
TRADE MARK REG

NEW MAGNETIC STABILIZER

This modern lamp produces all the light there is. . . . It is the standard equipment of the nation's largest and finest theatres. . . . Used by 90% of the largest Drive-In Theatres.

It is the "Omega" for maximum screen brilliance Nothing can even approach it in white light volume when used with projectors that have efficient revolving shutters.

Assures satisfying projection for Drive-Ins regardless of the size of the picture, length of throw, and under all weather conditions. . . . They are Und. Lab., Inc listed and, therefore, not insurance hazards. . . . Heat filter assures no risk of film-heat damage at maximum arc amperage and maximum screen lumens.

"WHY EXPERIMENT?"



J. E. McAULEY MFG. CO.

552-554 WEST ADAMS STREET
CHICAGO 6, ILLINOIS

B 293321

MAR 21 1951

INTERNATIONAL PROJECTIONIST

With Which Is Combined PROJECTION ENGINEERING



HENRY B. SELLWOOD, *Editor*

Volume 26

MARCH 1951

Number 3

Index and Monthly Chat	3	In the Spotlight	18
Film-Guiding in the Projector . . .	5	HARRY SHERMAN	
ROBERT A. MITCHELL		IA Elections	20
Theater Television via the RCA		The Cathode-Ray Tube: Basic	
PT-100 Equipment, IV	9	Data	21
RCA SERVICE COMPANY		JOHN F. RIDER and	
Projectionist Examination Ques-		SEYMOUR D. USLAN	
tions	10	Variable Shutters in 16-mm	
New Eastman Identification Sys-		Filming	23
tem for Safety Film	12	JOHN F. FORBES	
KODAK RESEARCH LABORATORIES		Letters to the Editor	24
Effects of Television on the Mo-		RCA Theater-Tv Price Slash . . .	25
tion Picture Theater	17	News Notes	
BEN SCHLANGER and		Technical Hints	
WILLIAM A. HOFFBERG		Miscellaneous Items	

Published Monthly by

INTERNATIONAL PROJECTIONIST PUBLISHING CO., INC.

19 West 44 Street, New York 18, N. Y.

Telephone: MUrray Hill 2-2948

R. A. ENTRACHT, Publisher

SUBSCRIPTION REPRESENTATIVES

AUSTRALIA: McGills, 183 Elizabeth St., Melbourne

NEW ZEALAND: Te Aro Book Depot, Ltd., 64 Courtenay Place, Wellington

ENGLAND and DOMINIONS: Wm. Dawson & Sons, Ltd., Macklin St., London, W. C. 2

YEARLY SUBSCRIPTION: United States and possessions, \$2.50 (two years, \$4); Canada and foreign countries, \$3; single copies, 30 cents. Changes of address should be submitted two weeks in advance of publication date to insure receipt of current issue. Entered as second class matter February 8, 1932, at the Post Office at New York, N. Y., under the act of March 3, 1879. Entire contents copyrighted 1951 by International Projectionist Publishing Co., Inc. INTERNATIONAL PROJECTIONIST is not responsible for personal opinions appearing in signed articles in its columns.



420

MONTHLY CHAT

ONE of the most encouraging news items in many a day was the recent move by RCA to slash the price of its theater Tv system from \$25,000 to \$15,800. And the frosting for this palatable tidbit was the announcement that RCA was moving along in high gear production-wise, with no present indication that a shortage of Tv system elements will seriously hamper this production effort for some months to come.

This RCA move followed on the heels of the recent acquisition by 20th Century-Fox of the rights to the Eidophore (Swiss) system of large-screen Tv, a happenstance which is viewed in some quarters as having impelled the RCA price cut.

Now is posed the \$64 question, in two sections: first, what will Mr. Exhibitor do now that his moaning about the high cost of Tv equipment has been stifled? and second, even if the exhibition field displays the best will in the world to get theater Tv rolling, what aid will be given by the FCC in terms of allocating channels so that motion picture theaters may be afforded at least a fighting chance to stay on an even keel? This is quite apart from the extremely involved matter of proper program fare.

Nor is Mr. Exhibitor the only one concerned here: projectionists and every other member of the organized crafts in the industry has a big stake on the line—their livelihoods. In fact, during an informal discussion at a recent exhibitor gathering the suggestion was voiced that the labor organizations in the industry, in particular the IA, should come to the aid of the theaters by advancing up to \$500,000 for Tv equipment in about 100 theaters in key cities across the country.

It is not known how the labor organizations would react to such a proposal, but the idea is by no means fantastic.

However all this may be, the expansion of theater Tv now rests squarely in the lap of the FCC, for it is incredible that the film industry, if given the opportunity, would not devise some means for solving the problem of equipment finances and programming.

Now is the time for all groups within the film industry to put aside their own selfish interests and strive mightily for the common good—and this advice is pointed directly at the film distributors who have yet to curb their voracious appetites in terms of exorbitant film rentals. And the organized crafts within the industry can make a signal contribution to the solution of this knotty problem, and this without renouncing one whit of their hard-earned right of collective bargaining. Working together as a team, this problem is by no means insoluble.

Failing a cooperative effort by all concerned, it is difficult to see how the once-proud film industry can emerge from the box-office doldrums.

"VICTORY CARBONS" are back to conserve copper for defense



A National emergency has been declared. Our country is in grave danger. National Carbon Division is helping to conserve vitally-needed copper for use in defense . . . by putting a thinner coating on the following sizes of projector carbons:

- 8 mm x 14" "SUPREX" Positive
- 8 mm x 12" "SUPREX" Positive
- 7 mm x 9" "OROTIP" "C" Negative
- 7 mm x 14" "SUPREX" Positive
- 7 mm x 12" "SUPREX" Positive
- 6 mm x 9" "OROTIP" "C" Negative

The above carbons will be called "Victory Carbons" and will operate at the reduced currents shown:

- Maximum 65 amperes—8 mm "SUPREX" Positives
- 7 mm "OROTIP" "C" Negative
- Maximum 45 amperes—7 mm "SUPREX" Positives
- 6 mm "OROTIP" "C" Negative

The terms "National", "Orotip" and "Suprex" are registered trade-marks of
NATIONAL CARBON COMPANY
 Division of
UNION CARBIDE AND CARBON CORPORATION
 30 East 42nd Street, New York 17, N. Y.
 District Sales Offices: Atlanta, Chicago, Dallas,
 Kansas City, New York, Pittsburgh, San Francisco
 In Canada: National Carbon Limited, Toronto 4

There will be enough carbons to go around. The only change will be in the thickness of the copper coating. "Victory Carbons" aren't new. They helped us in the last war. They are helping us now to prepare for the next one, if it comes.

MAR 21 1951



Film-Guiding in the Projector

By ROBERT A. MITCHELL

INTERMITTENT units and projection lenses have often been blamed for picture defects actually caused by film gates, or "traps," which were worn, misaligned, or otherwise maladjusted. Projectionists who operate in a large number of theatres as relief men or service engineers occasionally encounter projectors clogged with dirt and oily grime—positive indications of neglect. Removal of the accumulated dirt frequently reveals mechanical troubles which can, and often do, have a deleterious effect upon the projected picture.

The mechanical and optical tolerance of the film gate's various parts are so critical that the slightest amount of wear and maladjustment can prevent the gate from holding the film perfectly flat and motionless over the aperture during the 24 definite intervals each second when the intermittent is "at rest." A lateral or a longitudinal extraneous movement of the film of only 0.01 inch will show up on a 24-foot screen as a sidewise or an up-and-down picture movement of nearly 3 inches! And a deviation from perfect flatness of the film by the same amount, or even less, will cause one side or corner of the picture to be badly blurred when the central areas are in focus.

Older Gates Unsatisfactory

Even a perfect intermittent unit cannot produce a rock-steady picture without a trace of flutter and side-sway when the gate fails in its function. Neither can even the best lens work against such a handicap.

The gates of the older projectors are manifestly unsatisfactory. The anti-

quated Powers, for example, utilizes a very short gate (about 3 frames of film in length), and accordingly requires a powerful pad tension to prevent over-shooting when brand-new prints are shown. The poor construction of the gate is the principal reason why Powers-projected pictures frequently have fits of violent "jumping." The projectionist can only risk film damage by increasing pad tension beyond safe limits.

The old Simplex "Regular" is another case in point. The gate of this machine—originally the Edengraph—is vastly superior to the Powers gate. It is longer, it has more evenly distributed pad tension, it is fitted with an effective cooling plate, and it has a larger flanged guide roller which, unlike the Powers roller, is easily adjusted for correct lateral placement of the film over the aperture. But the single guide roller of this machine, and of others patterned after the old Simplex, is not sufficiently effective to eliminate all side-sway from the picture.

Pad Tension Adjustment

The pad tension provided in the older projectors was another source of projectionist dissatisfaction. This tension should be decreased when running new prints which are apt to "stick," and increased for well-seasoned prints. It was difficult to change the tension of the pads, or shoes, because the springs had to be taken out of the gate door and bent with the fingers. The busy projectionist

was thereby forced to resort to guesswork, and he could not bring about the desired changes in pressure on the film when old and new prints were run on the same program.

The situation was also confused by differences of opinion. One projector manufacturer declared flatly that fixed pad tension represented the best projection practice, and he cautioned the projectionist not to attempt to alter the tension provided at the factory. This, of course, was many years ago.

All of these constructional flaws have received the close attention of projector designers in recent years; and all but a few of the newer projectors have better gates than the best of the old-time machines. We find improved edge-guiding of the film and readily adjusted pad tension. In some cases alloy steels of superior wearing qualities are used for the tension shoes and film runners.

An examination of all the different projectors, both old and new, discloses three general types of film gates. These are represented in Fig. 1. Gate *A* is the old type, now obsolete. It depends for lateral guiding of the film upon a single flanged guide roller placed at the top of the main casting.

Gate *B* represents an attempt to improve the film-guiding by placing a metal guide rail at each edge of the film track. Gates having "studio guides," as these rails are called, are found in the Motiograph K, the Simplex E-7 and X-L, and the Brenkert projectors.

Gate *C* has no studio guides, but uses instead a second guide roller positioned a

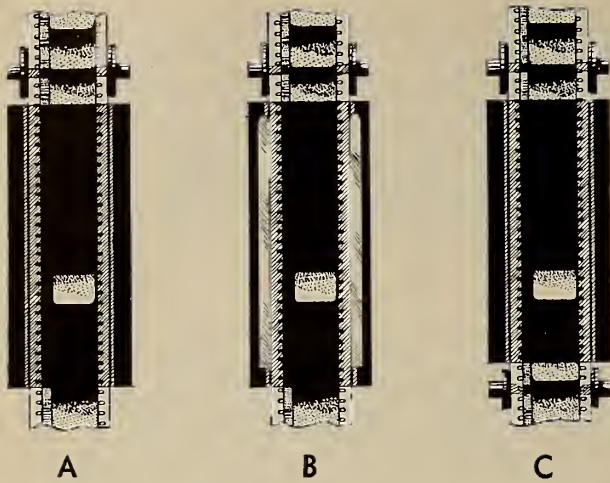

FIGURE 1

Three main classes of film gates: A—gate with no guiding-edge facilities except a single guide roller assembly at top of main film-trap casting; B—gate with guide roller and guide rails, and C—gate with two guide-roller assemblies.

short distance below the aperture. This type of gate is an exclusive feature of the Motiograph AA. Fig. 2 shows the actual construction of this advanced type of film gate.

Curved Gate an Aid

In addition to these the *curved gate* may be added as a fourth class. The reader will recall that the Super Simplex adapted for the projection of 70-mm Grandeur film utilized a curved gate. Theoretically, the curvature of the Grandeur gate is in the wrong direction for good optical functioning of the lens—the concavity, not the convexity, should face the lens.

In the SUPA line of projectors we see the curved gate correctly engineered. These British projectors are found on this side of the Atlantic mostly in Canada; and while they are unnecessarily complicated and possess features which make them seem very crude in comparison with American projectors, the curved gate impresses the writer as a distinct advance in projector design. Possibly, Mr. R. H. Cricks, Technical Editor of *Ideal Kinema* (London) had this feature

in mind when he lavished praise upon the chain-gearred SUPA.

The so-called flickerless projector exhibited at a TESMA convention in 1947 was an experimental model using a curved gate. Film-buckling is eliminated by the use of this gate.

It is now time to ask a few questions—questions which occur to all projectionists who try to evaluate the various gate constructions now in use. Are the additional edge-guiding facilities of modern projectors really necessary? Which is better, studio-guide aligning or the use of two sets of guide rollers, upper and lower?

No one knows *all* about equipment. The “expert” is sometimes wrong; and the ordinary projectionist is often right. Manufacturers hire skilled engineers and conduct mechanical, optical, electrical, and even chemical, tests unceasingly, often being more critical of their own products than are its users.

The development of the projector shutter from the single front shutter to the rear disc-shutter, and then to the combination front-and-rear shutter, and finally to such forms as the cylindrical and the conical shutters, is indicative of the great progress made. So also is the development of new types of film gates.

Varied Experience Suggested

Projectionists can increase their knowledge of the newer projectors by taking a look-see at as many different makes as possible. Visiting the projection rooms of theatres having different brands of equipment cannot fail to help the projectionist to form a sound opinion as to which projectors are really the best.

A comparison of the newer and older film gates makes a good subject for study on field trips. This study should be followed up by actually threading up different makes of machines with film, noting the ease of threading, and then examining critically the performance of each type of gate. The old-style gate is a good one to begin with.

Figure 3 is a diagram of the standard

type of guide roller used in these machines. The flange at the outer edge (sound track side) of the film is fixed, and therefore determines the lateral position of the film. The other flange is moveable, and is caused to press in upon the opposite edge of the film by a small coil spring. The entire assembly rotates upon pivot bearings.

The fixed flange of most guide rollers is provided with a set-screw to permit lateral adjustment. It is extremely important that the guide-roller assembly be properly centered in order to avoid the appearance of either the sprocket-hole margin or the soundtrack on the screen.

If a brand-new print be lubricated by smearing oil in an irregular manner over the perforation margins (a practice certainly not recommended!) a noticeable side-sway will be introduced into the picture when projected with one of the older machines.

Now, an appreciable amount of varying *slippage-difference* exists between the two sprocket-hole margins of practically all films. Side-sway thus exists *in potentia*; and any differences in the pad tension applied to the two margins of the film greatly increase the likelihood of annoying side-sway.

The possibility of side-sway may also be tested, and without messing up film, by pressing against each edge of the film, first one edge and then the other, *very lightly* with the back of the fingernail just below the intermittent sprocket. If any lateral movements of the picture appear on the screen during this test, the possibility of spontaneous side-sway is great with the mechanism used. Such a test must be conducted with caution in order to avoid injury to the fingers or damage to the film.

Use of 'Studio Guides'

In order to overcome this trouble several manufacturers sought improvements in gate construction. Motiograph was the first to use studio guides. These appeared in the Motiograph K in 1936. Later Brenkert and Simplex (in the E-7) adopted them. These two manufacturers still use studio guides in their latest models.

(Continued on page 32)

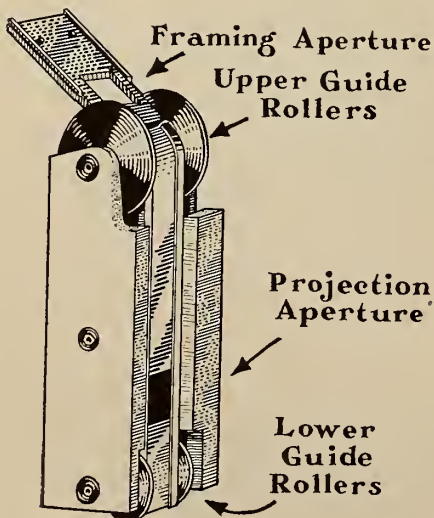

FIG. 2. Construction of the Motiograph AA film gate. Two sets of guide rollers are used to insure accurate edge-guiding of all film.

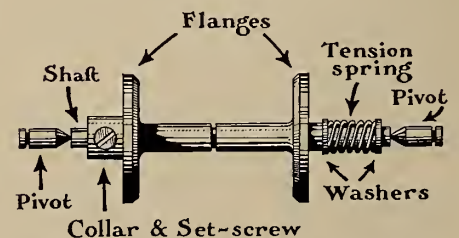
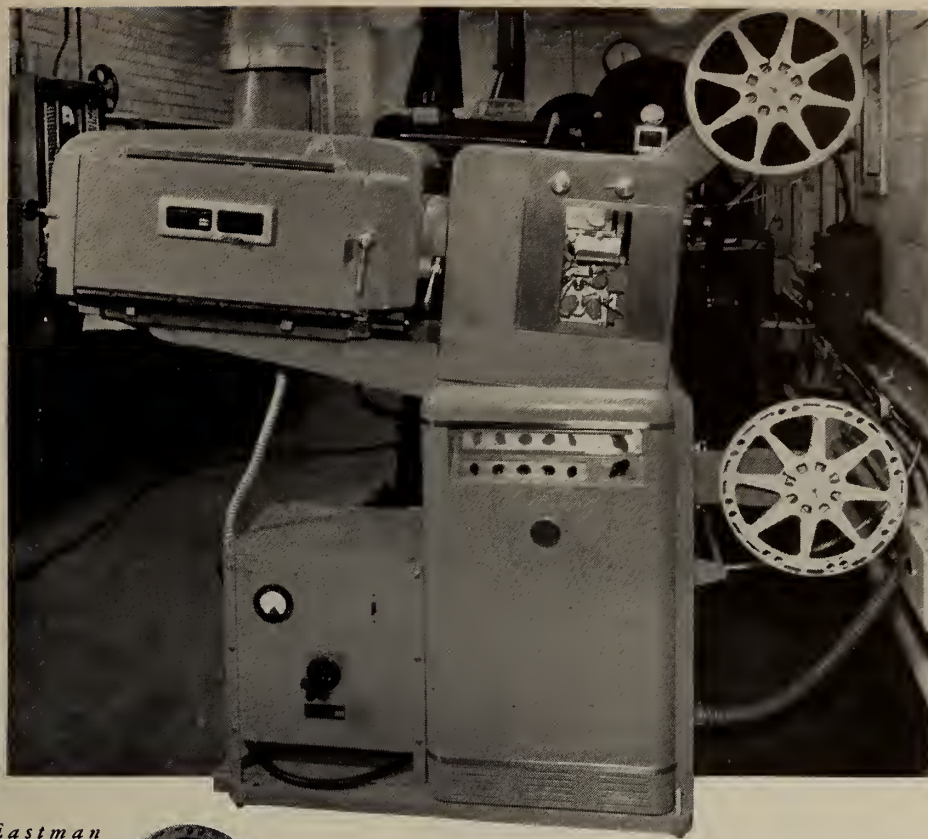
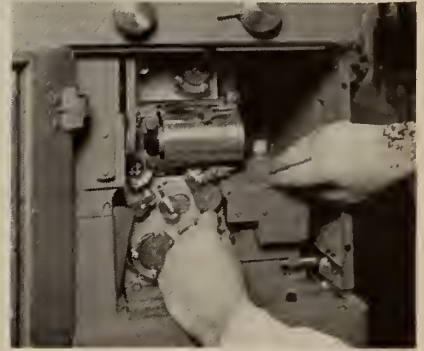

FIG. 3. A standard guide-roller assembly. Note the set-screw by means of which the roller may be adjusted laterally.



Left, the Eastman 16mm. Projector, Model 25, brings 16mm. projection to the professional level. Shown here, adapted for arc illumination, permanently installed alongside 35mm. equipment.

Below, working parts of the film movement mechanism are in constant view of the operator... readily accessible for threading and cleaning.



The Eastman 16mm. Projector, Model 25, adapted for 1,000-watt tungsten light.

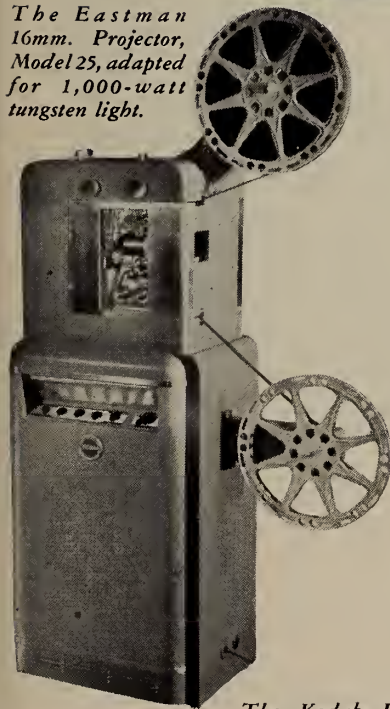

The Kodak Projection Ektar Lens, in a choice of four focal lengths, insures superior screen image.



East Coast Division
342 Madison Avenue
New York 17, N. Y.

For Professional Quality Sound Projection from 16mm. Film

The Eastman 16mm. Projector, Model 25

This projection instrument—built to a new design concept—eliminates the three major obstacles to theatrical quality 16mm. sound projection... excessive wear and high maintenance cost; low signal-to-noise ratio; and excessive flutter.

A major cause of excessive wear and poor quality sound is the constant transfer of shock forces generated in the film pulldown mechanism to other parts of the system. In the Eastman 16mm. Projector, Model 25, the intermittent (film advance mechanism) is completely isolated and independently driven by its own 1440 r.p.m. synchronous motor. Thus, shock forces are sealed off from the rest of the instrument. The sprocket-shutter system is driven by its own 1800 r.p.m. synchronous motor. Exact phas-

ing between the two systems is accomplished by specially designed synchro-mesh gears. In addition, the take-up spindle, rewind spindle, and blower are driven by separate motors.

A highly corrected microscope objective, adjustable for optimum sound quality from any type of 16mm. sound film, permits reproduction of variable area or variable density 16mm. sound tracks at extremely low distortion and a maximum signal-to-noise ratio.

To get the best out of any 16mm. sound film, project it on an Eastman 16mm. Projector, Model 25. For information on installation, availability, and prices, write directly to the Motion Picture Film Department, Eastman Kodak Company, Rochester 4, N. Y., or any branch office.

Motion Picture Film Department, Eastman Kodak Company, Rochester 4, N. Y.



Midwest Division
137 North Wabash Avenue
Chicago 2, Illinois

West Coast Division
6706 Santa Monica Blvd.
Hollywood 38, California

BRIGHTEN
UP YOUR PICTURES
WITH THE
LIGHT
OF THE
MIGHTY "90"

the lamp that does more than
just deliver the most light...

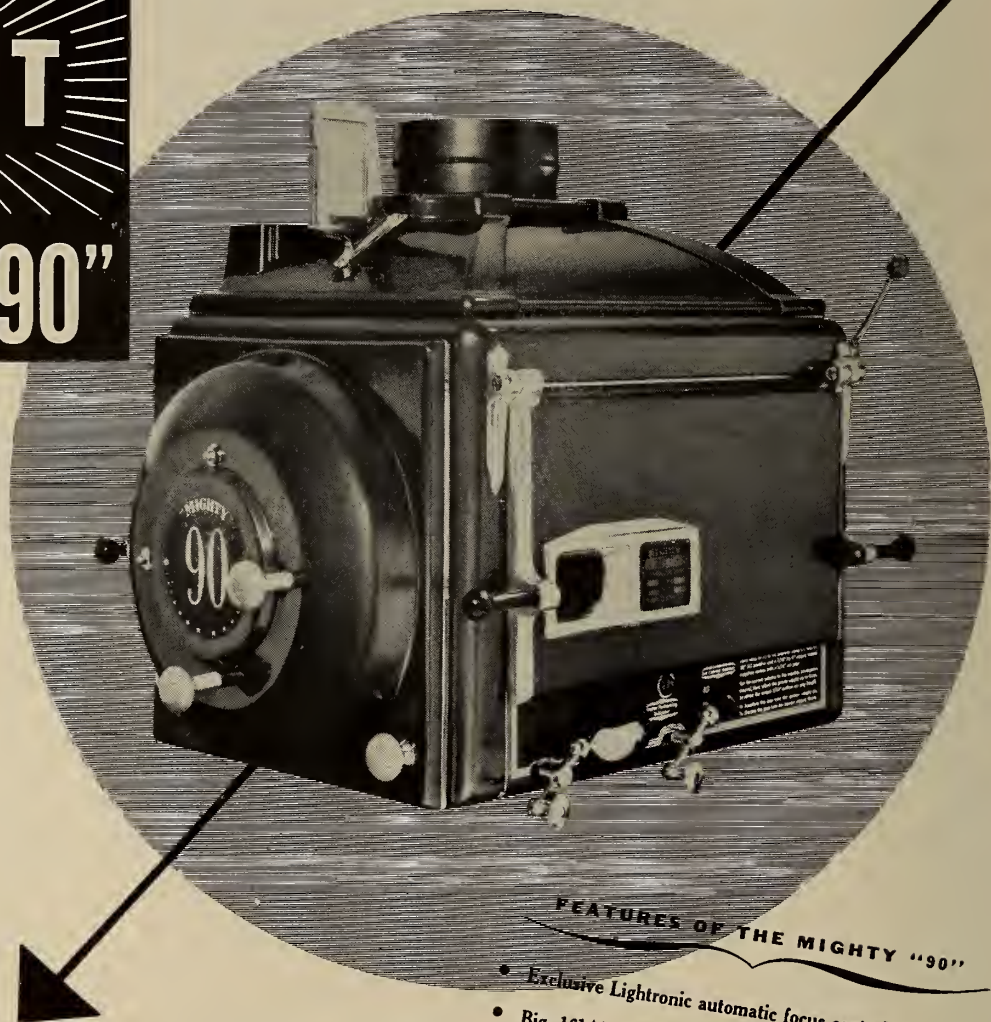

FEATURES OF THE MIGHTY "90"

- Exclusive Lightronic automatic focus control.
- Big 16 1/2" reflector, the largest used in any lamp, matches high speed f1.9 lens.
- Forced air cooled feed mechanism. Low operating temperatures. Rugged burner mechanism.
- Bi-Metal Lightronic tube controls both carbon feed motors. Simple feed rate adjustment.
- Air stream arc stabilization. Complete combustion of black soot. White deposit on reflector prevented.
- Unit construction permits instant removal of major components.

The Strong Mighty "90", 75 to 130 ampere reflector arc lamp, not only delivers positively the most light that can be projected to any screen, REGARDLESS OF HOW LARGE, but at 90 amperes projects 21,000 lumens AT FAR LESS COST than other types of big lamps!

As the only lamps produced complete within one factory, Strong lamps can be engineered to obtain these high efficiencies and fine screen results.

As the world's largest manufacturer of projection arc lamps, Strong has a line that includes lamps especially designed for best results under every condition. Send coupon today for free literature.

**THE
STRONG
ELECTRIC
CORPORATION**

3rd City Park Avenue

TOLEDO 2, OHIO

I would like a demonstration of the Strong Mighty "90" in my theatre without cost or obligation.

Please send free literature on the Mighty "90"; Mogul Lamp; Utility Lamp; Strong Arc Spotlamps; Strong Incandescent Spotlights; Strong Rectifiers; Strong Reflectors.

NAME _____

THEATRE _____

STREET _____

CITY & STATE _____

MAR 21 1951

Theater Television

via the RCA PT-100 Equipment

By TECHNICAL PRODUCTS DIVISION, RCA SERVICE CO., INC.

IV. Image Projection Equipment Data

THERE are several major differences between the theater television projector and the conventional home receiver. These are necessary mainly because of the larger size of the projected picture, the fact that the theater television projector is used for coaxial or microwave programs as well as broadcast programs, and the fact that it is designed for commercial applications.

Because of the larger size of the projected picture, and the increased illumination thereby required, the picture produced on the Kinescope screen must be much more brightly illuminated than that produced on a home receiver. This corresponds exactly to the fact that the picture aperture of a motion picture projector is illuminated to a much higher level than that of a photograph which is viewed directly.

Neither the projection Kinescope nor the frame of film in the aperture of the picture projector can be viewed directly without a protective glass to reduce the blinding brilliancy of the light. In order to produce this high light level, more voltage and more current must pass through the projection Kinescope than through the one in the home receiver.

80,000-Volt Anode Potential

The RCA PT-100 projector utilizes a Kinescope which is especially designed to be used with an anode potential of 80,000 volts, and a beam current of approximately two milliamperes, as contrasted with 10,000 volts and several microamperes for the home receiver Kinescope.

In order to successfully withstand such high voltage, the theatre projection Kinescope is made with an insulating outer

coating on the large part of the tube. In addition, this part of the Kinescope is made with corrugations, or "petticoats," around it to increase the surface leakage path for the applied voltage. The internal coating on the face of the Kinescope is covered with a thin backing of aluminum to equalize the voltage and reflect as much light as possible out through the front of the tube.

The high voltage is obtained from a power unit of the type used with high-powered X-ray equipment. This unit comprises a high-voltage transformer; a voltage-doubling rectifier, with filter capacitors and resistors; a voltage-regulating circuit, and safety relays to short-circuit the high voltage circuits when the applied A-C power is turned off.

All components are immersed in a steel tank filled with insulating oil. A tap is taken from the internal resistors to obtain 20,000 volts for the third grid of the projection Kinescope. The 20- as well as the 80,000-volt outputs are fed out of the steel tank by means of high-voltage cables protected by steel conduit; these cables run in this conduit to the inside of the metal projector barrel. Thus, there is no unprotected cable exposed. The power supply and control wiring for this unit is, of course, also run in conduit to the control racks.

Power Supply Controls

To prevent variations in the size of the projected picture due to line voltage fluctuations, the D-C supplies for the deflection amplifiers, video amplifier, oscilloscope, and synchronizing and switching amplifiers are all electronically controlled.

A-C power for the vertical deflection

amplifier, the horizontal deflection amplifier, one rectifier-power supply, and the 80,000-volt power supply is controlled by an automatic voltage-regulating transformer. Thus, the normal variations in A-C line voltage are prevented from affecting the operation of the projector.

As the Kinescope is located at a distance from the monitor and control racks, which are in the projection room, it is necessary to use a cable to feed power to the Kinescope for moving the electron beam up and down and back and forth on the Kinescope screen. Because it is necessary to feed the deflection power at low voltage and fairly high current, a coaxial cable is used, as it is most practical for this purpose. The deflection yokes on the Kinescope are specially wound to operate from this low-voltage, high-current supply.

The video (or picture) amplifier is located at the projector barrel, so the capacity in the high-level video output circuits is held to a minimum. In this way, signals reaching the control elements of the Kinescope have the full 8-megacycle range that the equipment is capable of handling.

Unique Adjustment Features

Several unique features are incorporated in the projection room rack equipment. A special oscilloscope is provided for testing and adjusting the peak-to-peak input voltage signal to be sure that it is adequate to fully control the picture circuits. A built-in switch allows the projectionist to check the calibration of this scope when necessary. This feature is intended to prevent picture failure which might otherwise occur from unknowingly trying to utilize a weak input signal.

There is also a monitor Kinescope which produces a miniature picture from the incoming signal, or, at the projectionist's discretion, of the signal after amplification in the video amplifier which is located in the projector barrel. This double-checks the incoming signal for picture content and the amplifier signal for distortion or other possible defects. It also helps the projectionist to cue changeovers from one program to another, as it can be switched to either of two incoming signal lines, and thus enables him to see one program while at the same time projecting the other on the theatre screen.

A monitor jack and phone headset are



The 7NP4 projection Kinescope used with the RCA PT-100 theater Tv system.

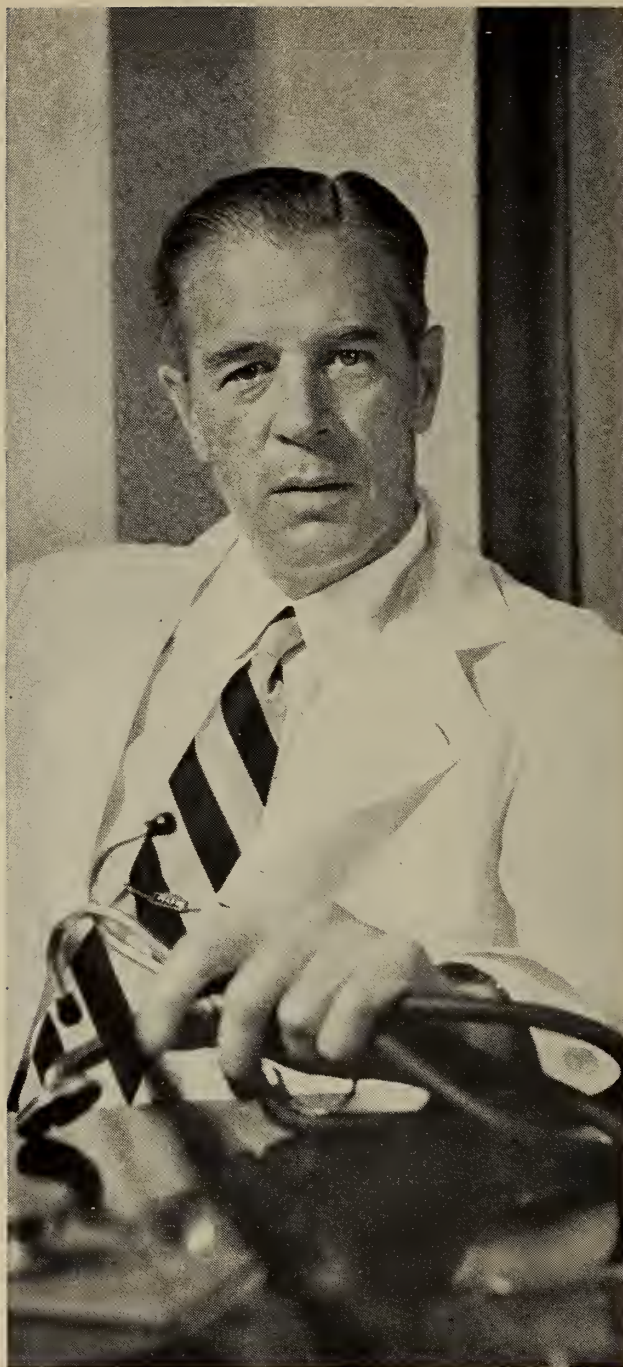

"Is it too late, Doctor?"

Fortunately, it's *not* too late for more and more Americans who are going to their doctors *in time* ...at the first sign of any one of the seven danger signals which *may* mean cancer: (1) any sore that does not heal (2) a lump or thickening, in the breast or elsewhere (3) unusual bleeding or discharge (4) any change in a wart or mole (5) persistent indigestion or difficulty in swallowing (6) persistent hoarseness or cough (7) any change in normal bowel habits.

By showing Americans what they can do to protect themselves and their families against cancer, the American Cancer Society is saving thousands of lives *today*. By supporting science and medicine in the search for the causes and cures of cancer, the Society hopes to save countless more *tomorrow*. To guard yourself, and those you love, against cancer, call the nearest office of the American Cancer Society or address your inquiry to "Cancer" in care of your local Post Office.

American Cancer Society



Projectionist Examination Questions

Based on Examinations by Leading U. S. Municipalities



Power supply unit for RCA theater Tv system.

also provided for listening to the incoming sound signal on either line. Again, it is possible to listen to some other line than the one being fed to the sound system in the theatre.

Special Beaded Screen Used

In order to provide maximum illumination in the theatre seating area, the screen used with the RCA theater Tv projector is of the beaded type. This construction is similar to that employed in screens for the usual 16-mm home projectors. The millions of small glass beads act as individual lenses which reflect the incident light back into the useable area instead of scattering it over the entire auditorium. Thus, the amount of light reaching the patrons' eyes is increased and waste light reduced.

Two benefits are obtained in this manner: in addition to the increase of light to the patrons' eyes, the contrast of the screen to the theatre walls is increased; the walls are left darker, and therefore the eyes are more relaxed and eye pupils opened to the extent encouraged by the screen brilliancy.

All high-voltage circuits are protected by covers with interlock switches which cut power from the equipment when the covers are opened. This prevents accidental contact and assures maximum safety for operating personnel.

The projector barrel is mounted on a pair of trunnion legs to allow it to be tilted up or down the required amount to center the picture vertically on the screen. Although a certain amount of centering adjustment may be done with the rack controls, it is desirable to keep the picture as near the center of the Kinescope face as possible; therefore, the picture is first centered on the tube and then the barrel is aimed at the center of the screen. Side-to-side adjustment is obtained by moving the trunnion legs

1. Upon striking squarely a transparent medium that is of even density and homogeneous throughout, light will (a) be refracted upwards; (b) be refracted downwards; (c) travel through it in perfectly straight lines, or (d) be diffused partly upward and partly downward.

2. If a generator supplies current to its circuit at 114 volts, and each main wire has a drop of 3 volts in it, what voltage is impressed on the lamps?

3. Motion picture film should be cleaned with a soft cloth saturated with (a) modified laundry soda solution (b) kerosene (c) commercially pure carbon tetrachloride, or (d) hot water in which has been dissolved a small quantity of soft soap.

4. The lens formed by cementing or placing two plano-convex lenses together is called (a) collector (b) concave (c) meniscus, or (d) bi-convex.

5. That quality or property of a lens which causes differently colored light to come to a focus at varying distances from the optical center of the lens is called (a) spherical aberration (b) chromatic aberration (c) lens action, or (d) refraction.

6. How do electrolytic condensers differ from other condensers?

7. Name the principal parts in a Geneva projector movement.

8. To obtain a 20-ft. picture at a throw of 90 ft., what size lens is needed?

9. Can you explain exactly what action takes place in a rectifier tube?

10. Can you name the main elements of a push-pull amplifying circuit and describe their function?

ADDENDUM

To the Editor of IP:

Question No. 7 of the examination

in the required direction at the point where they are attached to the mounting framework on the balcony front or other support.

Mounting the projector from the balcony or other theatre structure must be done in a safe and secure manner. As individual balcony structures differ in their design, the design of the mounting platform on each installation is left in the hands of a competent architect or structural engineer.

[NOTE: The fifth article of this series will contain additional detailed data on the theater Tv projection equipment, in addition to information on operating procedure.]

question in IP for February (p. 10) is in error. The question was:

Having an alternator with 12 poles and a speed of 1200 R.P.M. and a frequency of 60 cycles, at what speed must a synchronous motor travel to be in step with it if it has 8 poles?

Now, no alternator with 12 poles and a speed of 1200 R.P.M. will result in 60 cycles. The speed would have to be 600 R.P.M. The reason for this lies in the relationship between the number of poles (p) of the machine, its speed of rotation (n) in R.P.M., and the frequency (f) of the induced voltage in cycles per second, as follows:

At f cycles per second the induced voltage has a frequency of $60 \times 2f = 120f$ of alternations, because each cycle corresponds to two alternations. During one revolution of the machine p poles pass under each group of conductors, thus inducing p alternations. Consequently, the number of alternations per minute, is pn , so we have $120f = pn$.

Now, getting back to Question 7:

$$120 \times 60 = 12 \times n$$
$$120 \times 60$$
$$n = \frac{\quad}{12} = 600 \text{ R.P.M.}$$

not 1200 R.P.M. Now, for an 8-pole synchronous motor to be in step, it would go like this:

$$120 \times 60 = 8 \times n$$
$$n = 900 \text{ R.P.M.}$$

Not looking for any medals for the old eagle-eye stunt, but I think so highly of IP that I don't like to see an error of this nature stand uncorrected.

DON FRETCH

IA Local 164, Milwaukee, Wisc.

OOPS—and you're so right, Mr. Fretch. Anyhow, the crimson hue of our face is bleached a bit by the gracious manner in which the correction was tendered.—Ed.

From Five to 450 Emulsion Coatings

The emulsion coating department of Eastman Kodak Co.—where light-sensitive photo emulsion is coated on film base—used a stock of five emulsion coatings in 1906. Today that number has risen to more than 450, including several multi-layer coatings for color film. Total film production has increased many times in that period.

Westrex Recorders for Signal Corps

The U. S. Signal Corps has just acquired 14 newsreel recording systems from Westrex Corp., New York. Eight of these systems included Wall single-system sound cameras.

New Eastman Identification System for Safety Film

PROPER identification of nitrate and safety film, of course, is of paramount importance if accidents are to be prevented. The only safe practice is to assume that all 35-mm motion picture film is nitrate unless demonstrated otherwise.

A safe, simple, foolproof method for identifying nitrate and safety film correctly is not as easy as it might seem. For many years film manufacturers have printed the words "NITRATE FILM" at frequent intervals along the edge of film made on nitrate base, and the words "SAFETY FILM" along the edge of film made on safety base. This has usually been done by a latent image exposure at the time of slitting or perforating, and

The circulation side-by-side of both nitrate and acetate (safety) release prints has imposed severe demands upon the resources of the film manufacturer, the laboratory, the exchanges—and last, but by no means least, upon the projectionist who must deliver the sum total of industry effort, from story conception down through the manifold stages to the delivery of the finished product to the paying patron at the theater box-office.

Ever responsive to the requirements of the man who keeps the theater going, (Mr. Projectionist), Eastman Kodak Company has developed a system of print identification which should go far to ease the burden of projectionists, who utilize its product to translate a narrow ribbon of film into the dollars which provide the economic sinews for the world-wide operation of motion picture theaters. This article was prepared and is copyright by Eastman Kodak Company.

when a nitrate positive is printed from a safety master and a safety duplicating negative. The nitrate print carries not only its own identifying name in black but the words "SAFETY FILM" in white

production of a portion of a print on safety film which was found in the trade. A sample had to be burned to establish the identity of the base. Both black-and-white and color prints have also been seen frequently with a flash along the edge which virtually obliterates the nitrate or safety identification.

Additional limitations to this system of film identification are the fact that it is invisible in the raw stock and that every individual spliced strip of processed film in a roll must be examined.

It is thus apparent that the existing system of nitrate and safety base identification is entirely inadequate. Eastman Kodak Company has given a great deal of thought to this problem in recent years because of its importance in fire prevention. Many ideas have been suggested and it has finally been concluded that two separate identification systems for safety film are necessary. Two such systems are now being put in practice as follows:

Distinctive, Visible Frame-Line Printing

A scheme has been devised by which identification of the base can be combined with visible frame-line printing as shown in Figs. 3 and 4. Eastman Nitrate Motion Picture Positive, Sound Recording, and Duplicating films carry a width-



FIG. 1. A print on nitrate stock showing conflicting identifications printed through from a safety master positive and a safety duplicating negative.

the identification is visible only after processing.

This identification system was adequate as long as only nitrate film was used for professional 35-mm theater productions. Now that both nitrate and safety films are in general use, there is the danger of misidentification caused by printing through from a safety negative onto a nitrate print, or *vice versa*.

Figure 1 illustrates what can happen

printed through from the safety duplicating negative, and the same in black printed through from the safety master positive.

Obliteration of Markings

The original identifying name on a piece of film usually appears sharper than one resulting from a second generation print, but there is still a real danger of misidentification. In Fig. 2 is the re-

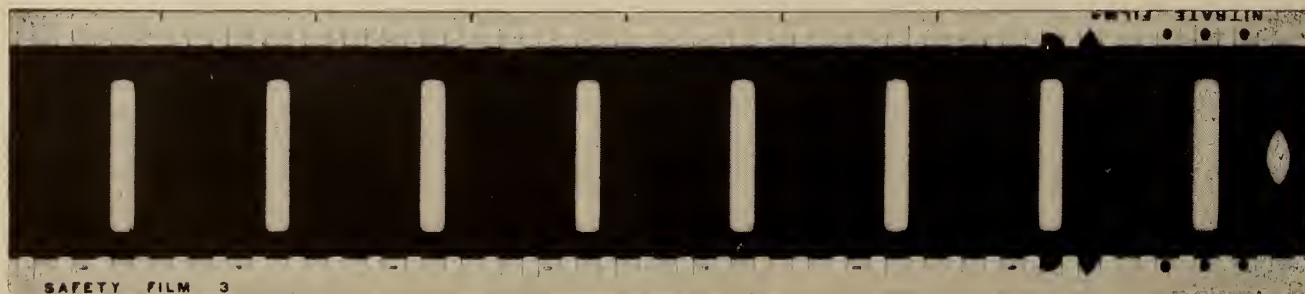

FIG. 2. A portion of a print on safety film stock found in a film exchange. Note confusion of identifying names. The correct identity can be established by the presence of the safety frame-line mark. (See Fig. 3.)



SHOWMANSHIP is better than ever—with RCA Theatre Sound

RCA SOUND

... completes the illusion of reality

REALITY OF PICTURE IS NOT ENOUGH... the sound, too, must be as real as life itself for the greatest possible enjoyment of the show. Today, the natural and pleasing sound made possible by RCA High Fidelity Sound Equipment successfully completes the illusion of reality.

RCA is the recognized leader in the sound equipment field.
RCA's more than 25 years' experience in research and

manufacture of sound equipment for motion picture theatres, radio and television stations and sound systems for educational, industrial and commercial applications is your guarantee of highest quality.

The RCA Service Company assures you of expert installation and keeps your RCA Theatre Sound System running at peak efficiency.

THERE IS AN RCA SOUND SYSTEM FOR YOUR THEATRE

Ask your Independent RCA Theatre Supply Dealer for complete information



THEATRE EQUIPMENT
RADIO CORPORATION of AMERICA
ENGINEERING PRODUCTS DEPARTMENT, CAMDEN, N.J.

In Canada: RCA VICTOR Company Limited, Montreal



presenting THE NEW STRONG TROUPERETTE INCANDESCENT SPOTLIGHT

... for small theatres, schools, night clubs, TV studios and industrial shows, where physical dimensions and price are factors and where the tremendous light volume of an arc lamp is not necessary.



PROJECTS FAR MORE LIGHT THAN ANY CONVENTIONAL INCANDESCENT SPOTLIGHT

This increased brilliancy is made possible by a variable focal length objective lens system, a 5¼-inch silvered glass reflector, and Fresnel lens used with a standard 115-volt, 1000-watt prefocused projection type bulb.

As contrasted to the conventional incandescent spotlight, with which the spot size is varied solely by irisng, to result in substantial light loss, the Trouperette utilizes all the light through most of the spot sizes.

6 1/2 TIMES BRIGHTER HEAD SPOTS

Sharp edges from head spot to flood. Horizontal masking control can be angled at 45 degrees in each direction. Fast-operating color boomerang accommodates six slides. Height-adjustable mounting stand. Can be plugged into any 110-volt convenience outlet.



THE STRONG TROUPER HIGH INTENSITY ARC SPOTLIGHT

With variable focal length lens system for projecting a dazzling snow-white spot in larger theatres, ice shows, circuses, arenas, and coliseums.

Automatic arc control maintains a constant arc gap, free from hiss or flicker. A trim of carbons one hour and 20 minutes at 21 volts and 45 amperes.

Draws only 10 amperes from any 110-volt A.C. convenience outlet, making the use of heavy rotating equipment unnecessary. An adjustable, self-regulating transformer is an integral part of the base. Mounted on casters. Easily portable. Easily disassembled for shipping.

SEE ANY OF THE FOLLOWING DEALERS OR USE COUPON FOR OBTAINING LITERATURE

ALBANY, N. Y.—Nat'l Theatre Supply Co.; Albany Theatre Supply
ATLANTA—Nat'l Theatre Supply Co.
ATLANTIC CITY—Boardwalk Film Enterprises
AUBURN, N. Y.—Auburn Theatre Equipment
BALTIMORE—J. F. Dusman Co.; Nat'l Theatre Supply Co.
BOSTON—J. Cifre, Inc.; Nat'l Theatre Supply Co.
BUFFALO—Dion Products; Nat'l Theatre Supply Co.
CHARLOTTE—Nat'l Theatre Supply Co.; Standard Theatre Supply Co.
CHICAGO—Abbott Theatre Equipment Co.; Gardner Jansen, Inc.; Hollywood Stage Lighting Co.; Midwest Stage Lighting Co.; Midwest Theatre Service and Equipment Co.; Nat'l Theatre Supply Co.
CINCINNATI—Nat'l Theatre Supply Co.
CLEVELAND—Nat'l Theatre Supply Co.
DALLAS—Hardin Theatre Supply Co.; Modern Theatre Equipment Co.; Nat'l Theatre Supply Co.
DENVER—Nat'l Theatre Supply Co.; Graham Bros.
DES MOINES—Nat'l Theatre Supply Co.
DETROIT—Nat'l Theatre Supply Co.
FORTY FORT, PA.—V. M. Tate Theatre Supplies
GREENSBORO, N. C.—Standard Theatre Supply Co.
HOUSTON—Southwestern Theatre Equipment Co.
INDIANAPOLIS—Nat'l Theatre Supply Co.
KANSAS CITY, MO.—Shreve Theatre Supply; Nat'l Theatre Supply Co.
LOS ANGELES—J. M. Boyd; C. J. Holzmueller; Nat'l Theatre Supply Co.; Pembrex Theatre Supply Corp.
LOUISVILLE—Falls City Theatre Supply Co.
MEMPHIS—Nat'l Theatre Supply Co.

MINNEAPOLIS—Minneapolis Theatre Supply; Nat'l Theatre Supply Co.
NEW HAVEN—Nat'l Theatre Supply Co.
NEW ORLEANS—Nat'l Theatre Supply Co.
NEW YORK CITY—Nat'l Theatre Supply Co.
NORFOLK—Nat'l Theatre Supply Co.
OKLAHOMA CITY—Nat'l Theatre Supply Co.; Oklahoma Theatre Supply Co.
PHILADELPHIA—Blumberg Brothers; Nat'l Theatre Supply Co.
PITTSBURGH—Atlas Theatre Supply; Nat'l Theatre Supply Co.
SALT LAKE CITY—Inter-Mountain Theatre Supply Co.
SAN FRANCISCO—C. J. Holzmueller; Nat'l Theatre Supply Co.; W. G. Preddey Theatre Supplies
SEATTLE—B. F. Shearer Co.; Nat'l Theatre Supply Co.

SIOUX FALLS—American Theatre Supply Co.
ST. LOUIS—City Electric Co.; Nat'l Theatre Supply Co.
TOLEDO—Theatre Equipment Co.
WESTERLY, R. I.—G. H. Payne Motion Picture Service
CANADA—
Dominion Sound Equipment, Ltd.
Montreal, Quebec
General Theatre Supply Co.
Montreal, Quebec
Perkins Electric Co., Ltd.
Montreal, Quebec
Perkins Electric Co., Ltd.
Toronto, Ontario
General Theatre Supply Co.
Winnipeg
Sharp's Theatre Supplies, Ltd.
Calgary, Alberta.

THE STRONG ELECTRIC CORP.
"The World's Largest Manufacturer of Projection Arc Lamps"
14 City Park Avenue
Toledo 2, Ohio

Please send free literature on the Strong Trouperette Incandescent Spotlight; Strong Trouper Arc Spotlight.

NAME _____
COMPANY _____
STREET _____
CITY & STATE _____



NITRATE FILM

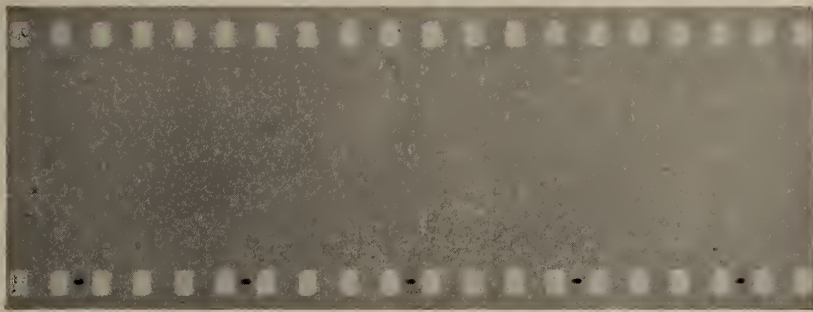

SAFETY FILM

FIG. 3. The new Eastman visible frame-line mark on safety raw stock compared with nitrate.

wise frame-line mark after every fourth perforation printed along the extreme edge of the film.

Eastman 35-mm black-and-white Safety Motion Picture Positive Film now carries a lengthwise frame-line mark after every fourth perforation located exactly between the perforations instead of at the extreme edge of the film. This is the only area on the film which is ordinarily not exposed in printing. This new safety frame-line mark when used on safety negative film will not print through on positive film, provided that care is taken to see that printers never expose the area exactly between successive perforations.

A more positive identification is thus obtained—whenever the new safety frame-line mark is found, one can be reasonably certain that the film is on safety base regardless of nitrate frame-lines or nitrate edge printing which may have been printed through from the negative. If the safety frame-line printing is not present, the film is either on nitrate base or on safety base made prior to the use of the new frame-line.

Black Ink Now Used

Both the nitrate and safety types of visible frame-line printing are applied to the back of the film by means of black ink instead of by latent image exposure and, therefore, are visible on the raw film (Fig. 3) as well as on the developed film (Fig. 4). The ink used will withstand processing solutions and normal handling wear. Even if the film is flashed before development, the ink is visible by reflected light, although not by transmitted light.

The new safety frame-line mark has

been used on 35-mm black-and-white Eastman Safety Motion Picture Positive Film since early in 1949. It will appear on all 35-mm Eastman safety motion picture films (both negative and positive types in black-and-white) as soon as the necessary equipment changes can be made—it is hoped, sometime during 1951. (All color films manufactured by Eastman Kodak Company are made on safety base but may not carry this new frame-line mark.) Of course, some Eastman safety film is already in circulation which does not have this new safety frame-line printing, but as time passes, this method



FIG. 4. The new Eastman visible frame-line mark on processed safety film compared with nitrate.

of identification should prove of increasing value.*

Attention is drawn to the fact that nitrate film formerly manufactured by Canadian Kodak carried a visible frame-line mark running lengthwise of the film instead of widthwise, as in the case of Eastman nitrate film manufactured in the United States (Fig. 5). The Canadian Kodak nitrate frame-line mark was located at the extreme edge of the film. It may therefore be distinguished from the new Eastman safety frame-line mark located between the perforations. Thus both the direction and the location of the frame-line mark must be checked to establish the identification of the base.

A Fluorescent Edge For Safety Film

The new visible frame-line printing described above as a useful and necessary method for identifying safety film, but it also has its limitations. In a spliced roll, every separate strip would have to be examined to make sure that the entire roll including leader and trailer was safety film.

Correct identification of the whole roll is especially important for sorting films going into storage vaults where a small piece of nitrate film might damage other films. It is also important in sorting film for scrap recovery. In such cases, individual examination of every spliced strip would be very laborious and costly. It was felt that some rapid method of determining whether or not a roll of film is all safety is necessary.

The method which has been adopted

*A distinctive type of frame-line mark for safety base motion picture materials manufactured in foreign countries is also being instituted.

Proper Handling of Safety Film

SAFETY motion picture film requires no special precautions in handling or storage as far as its own fire hazard is concerned. Underwriters' Laboratories describe approved acetate film as slow-burning and state that "hazards in use and storage are small, being somewhat less than those presented by common newsprint paper in the same form and quantity." Where safety film is used exclusively, only normal fire precautions are required as in any office or building containing paper, wood, or similar combustible material. Safety films should be stored in individual cans in metal cabinets, but these need not be sprinklered or vented.

Where safety and nitrate films are both being used in studios, laboratories, exchanges, theaters, or storage vaults, the same regulations and precautions must be followed as if *all* the film were nitrate. It is, of course, entirely feasible to segregate the work involving safety film alone in any given studio, laboratory, or exchange, so that certain areas might be operated without the restrictions applying to nitrate film.

The only real hazard in acetate film is that its increased

use will tend to make people careless, and proper safety precautions may be neglected while some nitrate film is still in circulation. If this happens, a serious accident may result.

Combination Safety-Nitrate Prints

A roll of film which is acetate base at the outside might contain nitrate film spliced in the interior of the roll. A print released on acetate stock may later have replacements made on nitrate stock and be run on a projector not properly maintained for nitrate film. A laboratory which has been using safety stock for release prints for a period of time may suddenly switch to nitrate stock without announcement or warning. The danger of such practices is obvious.

Even when no more nitrate film is being manufactured in the United States, foreign negatives or prints on nitrate stock may be imported. Another hazard is the quantity of nitrate negatives and prints in storage vaults, some of which may be kept for 25 years or more. Any such collection of nitrate films that is to be saved should be stored in a separate approved vault, never in the same vault with safety films.



FIG. 5. The visible frame-line mark on raw and processed nitrate film manufactured by Canadian Kodak.

by Eastman Kodak Company is to apply a very small amount of a fluorescent chemical on safety film base used for 35-mm motion picture film. When a 35-mm roll of film so treated is viewed on edge under a suitable ultraviolet lamp in a partially darkened room, a vivid purple fluorescence is visible; whereas untreated film viewed in the same way appears black. In white light fluorescent-treated and untreated films look exactly the same.

Extensive tests in both the laboratory and the trade indicate that the fluorescent treatment of the base has no detrimental effect on the film before or after development.

This simple and effective method of rapidly distinguishing nitrate and safety film in bulk form is illustrated in Fig. 6 which shows a composite nitrate and safety film roll on an exchange reel. The same roll wound on a core is shown in Fig. 7. The nitrate film appears black and the fluorescent-treated safety film ap-

pears white in these reproductions.

The contrast between the two films is much more striking in actual practice or in a color photograph where the edge of the safety film appears purple. The ex-

change reel does not permit as complete an examination as in the case of a roll on a core, but it is still possible to tell quickly whether most of the roll is nitrate or safety.

A suitable inexpensive ultraviolet lamp in various table, overhead, portable, spot, or flood-light models may be purchased from several manufacturers complete with transformer and filter ready for use.** A 100-watt bulb is recommended for general use, but smaller or larger ones may be obtained if desired. The ultraviolet bulbs and other parts may also be purchased separately from electrical supply stores and assembled in standard fixtures.

The ultraviolet lamp should be equipped with a hood or reflector, and care should be taken not to expose the eyes for long periods to direct ultraviolet radiation from these lamps. Provided such care is taken, ultraviolet lamps present no personnel hazard. They are in constant use in various other industries. (Continued next page, foot of Col. 1)

** For example, Switzer Brothers, Inc., 1220 Huron Road, Cleveland 15, Ohio, Black Light Model 103.



Figure 6



Figure 7

In Fig. 6 is shown a mixed roll of fluorescent-treated safety film (white) and untreated nitrate film (dark) on an exchange reel. (Photographed with ultraviolet light.) The edge of the treated safety film is actually colored purple, and the nitrate film black in ultraviolet light. Fig. 7 shows the same roll as in Fig. 6 but on a plastic core.

Effects of Television on the Motion Picture Theater[†]

By BEN SCHLANGER and WILLIAM A. HOFFBERG
Theater Architects and Engineers, New York City

The advent of television has accelerated the need for refinements and improvements in the art of the projected motion picture in theaters. The factors of cinematography, theater location, seating capacity and theater design have to be dealt with in accordance with circumstances which already appear to call for a fresh approach to the problem. It is important to evaluate the ability to adapt existing theaters to the new requirements.

HOME television is acquiring a mass audience, but there will always be a motion picture theater and theater television audience consisting of those patrons who wish to see entertainment not available in other mediums, those who wish to avoid advertising intrusions, those desiring a respite from the home environment, those satisfying their gregarious instincts, and those who prefer the dramatic impact of the large theater screen cinematography.

This audience may be surprising in numbers, because it has been estimated that only 10 to 20% of the potential audience ever attended even the most popular picture.

We are now going out of a period in motion picture history in which great leeway existed in both production and

exhibition. The margin for error, incompetence, and acceptability of questionable quality of production and exhibition, is narrowing down with the advent of television.

Now, the factor of quality in motion picture theater entertainment will determine the size of its audience. Of course, quality primarily includes story content and performance, but if the motion picture theater cannot deliver the story content and performance in a manner far superior to any of the other entertainment mediums, it will lose the main reason for its existence.

Television has accentuated the necessity for intimacy in the motion picture theater because each home television seat is a "ringside" seat. The television camera is located at a distance and angle from the scene which the director considers most favorable to the home audience. At home, the television viewer has the great advantage of choosing his seating pattern by individual preference.

However, the scale of the television screen in the home is limited. The comparatively bright illumination levels required in home television viewing makes the viewer particularly conscious of this deficiency. The inclusion of furniture and room details in the field of view does much to destroy intimacy.

In contrast with home television, the motion picture theater has a fixed seating pattern. The theater audience seating preferences can readily be seen as they choose their seats at the beginning of the show. The less desirable seats are then reserved for latecomers.

Theater Improvement 'Musts'

The competition of home television can be a healthy stimulus to induce theater owners to improve their physical plant so that the enjoyment of a motion picture in a theater is noticeably superior. The following items deserve careful consideration in this connection:

1. All theater seat locations must be desirable. Unobstructed vision of the

screen is mandatory. Ample row spacing and two arm rests for each seat will be necessary.

2. The scale of the theater screen image should increase so that the difference in scale as compared with the home television screen is accentuated and dramatized.

3. Since 1938, we have advocated the elimination of black masking around the motion picture screen, and we now have many successful installations of this type in theaters. The majority of television receiver sets have very light colored maskings. A luminous field around the screen, preferably synchronized with the screen lighting intensities, would reduce eyestrain and enhance peripheral cinematographical effects.

4. Some of the fluidity and inventiveness achieved in television production is worth noting. With the larger screen and luminous screen surround, the peripheral areas of the human field of view, can be exploited for greater dramatic effect.

5. The effectiveness of distant panoramic views and medium shots on the television receiver is necessarily limited in scale. In contrast, the larger theater screen and the increased use and improvement of wide-angle camera lenses, are great advantages.

Larger Screen Size Feasible

6. Development of higher intensity projection equipment, coated lenses, and the reduction of film grain as well as the demands of drive-in projection, have made larger screen projection feasible.

7. Further enhancement of cinematography is produced by the increased subtended angle of the larger screen to the average viewer.

8. Items 2 and 3 of the foregoing recommendations can now help to bring three-dimensional motion pictures into use. With seating depth limited to approximately four times the picture width instead of the greater viewing depths now used, objectionable perspective distortions experienced in stereoscopic viewing will be reduced. The elimination of dark picture surrounds is highly consistent with the realistic effect of stereoscopic viewing.

9. Stereophonic sound in theaters giving positional sound effects in space can hardly be conceivable in home television sound.

The foregoing suggestions for improve-

(Continued on page 29)

[†]J. Soc. Mot. Pict. & Tv Eng. for Jan., 1951, p. 39.

Safety Film Identification

(Continued from preceding page)

for example, for identifying markings on clothing in laundries.

CAUTION: A word of warning is in order in the case of laboratories using sensitized photographic materials because ultraviolet lamp bulbs contain mercury. If broken, care must be taken not to carry or track mercury into rooms where undeveloped film is stored or handled. Even slight traces of mercury produce sensitized spots on film which become black when developed.

It should also be pointed out that the above method of examination is intended for processed film only and that if used in the inspection of raw stock, fogging of the latter will result.

Fluorescent-treated film base is now being used for 35-mm Eastman Safety Motion Picture Positive stock (type 5302) and will be used for all 35-mm Eastman safety motion picture film without exception as soon as possible—it is hoped, in the early part of 1951.

IN THE SPOTLIGHT



By
**HARRY
SHERMAN**

WIDESPREAD craft interest in benefit and welfare plans, with many IA Locals now pondering the best manner of approach to suit their particular situations, prompts the publication here of the details of a plan which we have mentioned favorably previously (IP for March, 1949). We refer to the wage dividend which Eastman Kodak Company has paid to its employes for 39 consecutive years, with this year's payment of \$18 million going to about 45,000 employes throughout the United States.

Very significant, we think, is the Kodak statement that the plan "was started and continued in recognition of the part its men and women play in the success of the company." The wage dividend, which is paid in addition to regular wages and has no effect upon wage rates, is only one part of a broad program which includes sickness payments, life insurance, disability benefits, retirement annuities, and many special services.

Based on Company Earnings

The dividend is based on the cash dividends declared on the common stock during the year and on individual earnings over a five-year period. Eligible persons receive \$27.50 for each \$1000 earned at Kodak during the five years 1946 through 1950. Persons with Kodak five years at the end of 1950 receive dividend checks of about seven times their average weekly wages during the five-year period.

However, all employes who started on or before October 1, 1950, and who were at work on the last day of last year, will receive the dividend. Those who joined Kodak after October 1 last, but before January 1 of this year, will receive it if they are at work on the day of payment. Temporary absence on the qualification date does not affect eligibility.

Under the Kodak plan, for each 20 cents by which the cash dividends declared on the common stock exceed 70 cents, the wage dividend rate is $\frac{1}{2}$ of 1%

(.005) of all earnings within the five calendar years preceding the date of payment.

Since total cash dividends declared on the common stock during 1950 amounted to \$1.80, here is how the formula works: \$1.80 minus 70 equals \$1.10. Dividing this by 20 cents gives 5.5. Multiply 5.5 by .005 to obtain the wage dividend rate of $2\frac{3}{4}\%$.

Enlightened Business Management

To determine the individual's wage dividend, his earnings during 1946-1950, are multiplied by the 1950 wage dividend rate of $2\frac{3}{4}\%$.

That's how Kodak does it; and it is an outstanding example of social consciousness on the part of enlightened business management.

• Failing to conclude a satisfactory contract renewal with the owner of the Majestic and Allen Theaters in Lima, Ohio, Local 349 pulled its men and picketed the theaters. After five weeks of picketing the strike was finally settled when the wife of one of the striking projec-

tionists bought the Majestic and immediately signed a new contract with the Local calling for a wage increase of 15c per hour.

• The New York City Board of Education recently elected Morris J. Rotker, member of Local 306, to the chairmanship of the School Board for the Borough of the Bronx. Morris is a past president of the 25-30 Club, and his new appointment comes as no surprise to his many friends who know of his deep interest in civic matters.

• The members and officers of IA Locals 78 and 236, Birmingham, Ala., were commended by the Birmingham Civil Defense for donating their services to the presentation "If an 'A' Bomb Falls," which was shown there under the auspices of the U. S. Army and the U. S. Air Force Recruiting Service in cooperation with the Birmingham organization. The first showing of this sketch was made at the Temple Theater on January 25 last, and so great was the demand for tickets that it had to be shown again at the Municipal Auditorium on Febru-

DICK GREEN, MEMBER OF LOCAL 165, HOLLYWOOD, CALIF., HONORED AT DINNER



Hollywood Local 165 presented Dick Green, former IA official and popular member of the Local, with a gold life membership card at a dinner party tendered at the Riviera Country Club in Los Angeles on February 21 last. The dinner was held at the close of the annual meeting of Calif. District Council No. 2, and was attended by 93 delegates from Southern Calif. IA Locals.

Shown in the picture above (left to right) are: Howard Edgar, sec., Hollywood L. 165; Floyd Billingsley, 3rd IA vice-pres., and bus. rep., San Francisco L. 162; Steve Newman, IA rep.; Carl Cooper, 7th IA vice-pres., and bus. rep., Los Angeles L. 33; Ed Eagan, pres., L. 165; Dick Green; Billy Wise, bus. rep., San Diego L. 297 and pres. Calif. Dis. Council; Lon Bennett, sec., Long Beach L. 521, and sec. Calif. Dis. Council; Roy Brewer, IA rep., and Zeal Fairbanks.



Reelected to office by acclamation is the proud distinction of the official family of Hudson County Local 384. Shown here are the officers as they were obligated at the regular February meeting: (left to right) Frank Maurus, exec. board; James Saponar, sgt.-at-arms; John Cantoli, sec.-treas.; Frank Mandrake, who is rounding out his 21st year as president of the Local; Albert De Titta, exec. board; Ralph DeMea, bus. rep., and Ira Dulberger, cor.-rec. sec. George Wedemeyer, vice-pres., and Charles May, exec. board member, were not present on account of illness.

ary 22. The services of the two IA Birmingham Locals were donated at each performance.

- The recent death of Leon Lonis, member of Local 228, Toledo, Ohio, ended the career of one of the Local's oldest and most active members. Lonis joined the Local in April, 1914, and for the past 30 years worked in the projection room of the Royal Theater. He is survived by his wife, Lyda, and a sister.

- A dinner party marked the recent 40th anniversary celebration of Local 188, Kalamazoo, Mich. A goodly crowd turned out to celebrate the event, which was held at Louie's, a popular restaurant in Kalamazoo. Leeman J. McCarty, secretary, provided one of the highlights of the evening when he ran off several reels of movies taken about 20 years ago of past and present members of the Local. Another was the presentation of gold life membership cards to charter members Harry Miller and George Heath, members of the Local for the past 40 years.

- A recent ruling by the NLRB of Washington, D. C., held that the so-called "featherbedding" ban of the Taft-Hartley Act does not prohibit unions from seeking actual employment for members, even though the employer involved "... does not want or need such services and is not willing to accept them." This ruling applied specifically to the case involving the Palace Theater in Akron, Ohio, and Local 24 of the Musicians' Union, AF of L (IP for June, 1950, p. 20). The union demanded that the theater employ a standby orchestra to play a certain number of separate

engagements as a condition to the Local giving its consent for traveling name bands to play at the theater. In accordance with the majority ruling of the Board, the complaint against the union was dismissed.

- Tucson Local 415 celebrated its 25th anniversary with a breakfast at the Santa Rita Hotel coincidental with the February mid-winter meeting of the IA Executive Board. IA President Walsh, who presided at the Board meeting, was the guest of honor at Local 415's breakfast party and made several presentations on behalf of the Local. W. P. Raoul, IA secretary-treasurer, Mayor J. O. Niemann, and a number of Tucson's civic

and labor leaders were among the invited guests.

- A note from Richard Salamone, business representative for Local 723, Norwood, Mass., advises us that Andrew E. Grigun, the Local's popular secretary, became the father of a baby girl. Congratulations, pop.

- California District Council No. 2 held its annual meeting February 20 last at the Riviera Country Club in Brentwood, a suburb of Los Angeles, with the usual large turnout. The delegates witnessed a demonstration of the RCA large-screen Tv, which was put on by the management and projection crew of the Orpheum Theater in L. A. While they all spoke very favorably of the demonstration, they considered the cost of \$40,000 for the installation of the equipment to be a serious drawback to its widespread use in theaters. (Since then this has been reduced to \$15,800, according to a recent RCA announcement.)

Many of the delegates reported new contracts calling for cost-of-living increases.

Hollywood Local 165 tendered an excellent dinner to the delegates and guests, a feature of which was the presentation of a gold life membership card to one of its outstanding members, Dick Green, former IA secretary-treasurer. Merle Chamberlain and Walter McCormick, of the Hollywood Local, were in charge of entertainment arrangements.

- The recent death of Edward C. Siegfried, charter member of St. Louis Local 143, removes from its roster one of the few remaining old-timers. Survivors are his wife and a daughter.

Other Local 143 charter members are

MISSOURI STATE ASSOCIATION HOLDS ITS ANNUAL MEETING AT JOPLIN, MO.



Delegates and visitors to the Missouri State Association Convention pose on the steps of the Connor Hotel in Joplin, Mo., where the meeting was held on January 23 last. In addition to the delegates from the IA Locals in Missouri, representatives from the National Theatre Supply Co., Altec Service Corp., and RCA were in attendance. Felix D. Snow, 6th IA vice-president, may be seen in the front row, fifth from the left.

LOCAL 188 HONORS CHARTER MEMBERS



Harold Sargent (right), vice-president of Local 188, Kalamazoo, Mich., presents gold life membership cards to Harry Miller and George Heath, charter members of the Local.

A. P. Petill, Geo. O'Rafferty, and F. W. Kessler.

- We were sorry to learn that Roy Cogdill, former business representative for San Antonio, Local 407, is hospitalized. We hope his recovery will be a speedy one. Roy did a swell job in settling the long drawn-out strike of the Local against the Saragoza Amusement Co.

- It does our old heart good to get a letter from one of the smaller IA Local Unions telling us how they improved working conditions for their members. Such a letter is the one we received recently from V. (Dip) Vaught, president of Local 328, Pine Bluff, Ark.

Although the projection room of the theater where Dip has been working for the past 26 years has proper sanitary and ventilating facilities, he spent considerable time and effort in trying to get all the other theater owners in the Local's jurisdiction to make the same

provisions in their theaters. Failing this he contacted the mayor of his city, who brushed him off to the Health Department.

The director of the Health Department passed him on to one of his underlings, who, in turn, stated that he would take the matter up with the State Health Department. Not hearing from the State Health Department within a reasonable period of time, Dip communicated with the director of the State Labor Department, who, incidentally, happens to be a good friend of his. This seemed to do the trick, for within the next few days a representative from the State Health Department got in touch with Dip and immediately thereafter a careful check was made of sanitary and ventilating facilities in all the theaters. Recommendations were made to the delinquent theater owners, who lost no time in acting on them.

While it is true that Pine Bluff had no laws at the time which would have forced the theater owners to make the necessary improvements, the latter were aware of the fact that no time would be lost in remedying the situation, and that if legal steps had to be taken to force them to act on the recommendations, they probably would find it pretty costly.

Now, writes Dip, all theaters in Pine Bluff, including the drive-ins that are located outside the city limits, are equipped with toilets, wash basins, and are properly ventilated.

Local 328 also enjoys a share-the-profit plan with various exhibitors, in addition to wage increases of 7½%, and two-week vacations with pay, which were granted with the signing of new contracts in January of this year. We know of larger IA Locals that cannot match these conditions.

WALTER BURROWS AWARDED LIFE MEMBERSHIP CARD IN TUCSON LOCAL 415



One of the highlights of the recent 25th anniversary breakfast of Tucson Local 415 was the presentation by IA President Richard Walsh of 25-year emblems to six members of the Local, one of whom, Walter Burrows, secretary, also received a paid-up life membership card. Walsh, third from right, is shown presenting the card to Burrows. Looking on are Wm. P. Raoul, IA secretary-treasurer (extreme left), and the five members who received the 25-year emblems (left to right): Gonzales E. Martinez, Wm. H. Witt, Albert Runkle, A. J. Denny, and Richard Yrigoyen.

IA ELECTIONS

LOCAL 188, KALAMAZOO, MICH.

John Brill, *pres.*; Harold Sargent, *vice-pres.*; Leeman J. McCarty, *sec.*; Howard Woods, *treas.*; Arlo Slentz, *bus. rep.*

LOCAL 204, LITTLE ROCK, ARK.

Jack Schoemaker, *pres.*; Robert Baldrige, *vice-pres.*; Paynter Rochelle, *rec. cor.-sec.*; Guy Myers, Jr., *fin.-sec.*; Guy Redmond, *treas.*; Ira Baldrige, *bus. rep.*; Leonard Thalmueller, *trustee*; Charles Cates, *sgt.-at-arms.*

LOCAL 224, WASHINGTON, D. C.

Charles Franks, *pres.*; Charles Fischer, *1st vice-pres.*; Milton Bittenbender, *2nd vice-pres.*; T. DeWitt Bittenbender, *3rd vice-pres.*; Willard Garcia, *4th vice-pres.*; Alfred Mueller, *sec.*; T. LeRoy Hopkins, *fin.-sec.*; Carl Fowler, *treas.*; Ralph Grimes, *bus. rep.*

LOCAL 343, OMAHA, NEBR.

Alvin Kostlan, *pres.*; R. L. McIntyre, *1st vice-pres.*; Art Krake, *2nd vice-pres.*; Clyde Cooley, *corr.-sec.*; R. V. Mortenson, *fin.-sec.*; Ross Hatton, *treas.*; Howard Jackson, *bus. rep.*; R. L. Harrington, Mace Brown, P. W. Pollard, *trustees*; Al Frazier, *sgt.-at-arms.*

LOCAL 384, HUDSON COUNTY, N. J.

Frank Mandrake, *pres.*; George Wedemeyer, *vice-pres.*; Ira Dulberger, *cor. rec.-sec.*; John Cantoli, *sec.-treas.*; Ralph DeMea, *bus. rep.*; Frank Maurus, Albert De Titta, Charles May, *exec. board*; James Sapanar, *sgt.-at-arms.*

LOCAL 444, NEW KENSINGTON, PENNA.

Phil (Blackie) Bordonaro, *pres.*; Walter Austin, *vice-pres.*; F. P. (Reel) McCoy, *sec.*; Charles Wolfe, *treas.*; J. J. McCloskey, *bus. rep.*; Ralph Milberger, Joseph Mikelic, H. L. Wolfe, *trustees*; Clyde Johnson, Bernie Zamperini, Joe Kaduk, Joseph Milburn, *exec. board*; Anthony Haczak, *sgt.-at-arms.*

CALIFORNIA DISTRICT COUNCIL NO. 2

William Wise (San Diego L. 297), *pres.*; Ralph Adams (Santa Ana L. 504), *vice-pres.*; Alonzo S. Bennett (Long Beach L. 521), *sec.-treas.*; John H. Gotchell (Santa Barbara L. 442), Harry E. Reynolds (San Bernardino L. 577), Art Narath (Santa Ana L. 504), *trustees*; G. A. Lahlum (Long Beach L. 521), *sgt.-at-arms.*

National Theatre Supply Meet

New products and services to be offered to exhibitors in 1951 was the keynote of the first of a series of district sales meetings of National Theatre Supply representatives held at Hotel Hollenden, Cleveland, February 8th and 9th.

Sales personnel attending included managers and salesmen from Indianapolis, Cleveland, Detroit, Cincinnati, Buffalo and Pittsburgh branches. From the company's executive offices in New York were W. E. Green, President; J. W. Servies, District Supervisor; W. J. Turnbull, Sales Promotion Manager; and J. E. Currie, Drive-In Theatre Department Manager.

The Cathode-Ray Tube: Basic Data

By JOHN F. RIDER and SEYMOUR D. USLAN

This is the third and final article of a series* anent the principles of electrostatic action which governs the operation of the cathode-ray tube. These data appeared originally in *Encyclopedia on Cathode-Ray Oscilloscopes and Their Uses* and are published here by permission of John F. Rider**, publisher of this authoritative 982-page book.

FIGURE 7 shows a pattern of the electrostatic field between two like charges. Whether they are two positive or two negative charges is immaterial; we show two of the latter simply as a matter of choice. If they were two positive charges, the field still would be the same.

Let us examine this field pattern somewhat critically. The first condition we note is that there seem to be no termination for the lines of force. Why not? The answer is simply that we show only a portion of the fields associated with these two like charges. In reality, each of these two like charges has its own field point. It is to these unlike charges that the lines of force shown in the figure continue. In other words, when we show the field between two like charges, we really are showing only that section of each of two fields, extending between two unlike charges, which is in the proximity of the two like charges.

It is conceivable, in theory, to visualize these two like charges isolated in space, each with its field extending to infinity, and to describe a direction for each line of force according to its effect upon a "test" electron (one which is placed in the field for determination of lines of force). In accordance with this idea, the directions of the lines of force which face each other would be the same.

However, the reason for tying in the two like charges under consideration

with two other charges of opposite sign is that it permits the closest correlation with what is to follow. Fig. 8 is the drawing we shall use for discussion from this point on; this is the same, in substance, as Fig. 7, with the addition of the "remote" charges.

Repulsion Between Like Charges

A few differences exist between the two drawings, but in the main these are due to perspective, rather than to any actual difference in conditions. What we have done is to reorient ourselves relative to the imaginary lines of force. The fact that we illustrate two pairs of like charges instead of a single pair does not complicate the discussion. Whether it is a single pair of like charges or two pairs, the question remains the same: "What is the basis of the repulsion between like charges?"

Remembering that the attraction between unlike charges is attributable to the contracting properties of the lines of force, it is not too far-fetched to suppose that the repulsion likewise is due to some action on the part of the lines of force.

This is the case: it is the lateral repulsion between lines of force having like direction, which is responsible for the repulsion between charges. As is evident in Fig. 8, the direction of the lines of force facing each other and which join the two pairs of unlike charges is the same; these lines feel repulsive forces between them. Being attached to the lines, the charges likewise feel the same forces and move apart.

It is necessary to understand that the repulsion between similarly directed lines of force does not depend upon motion of the charges. In fact it is the reverse: the motion of the charges is due to the repulsive forces. These exist even if motion of the charges responsible for the fixed field cannot take place because of the nature of the system.

Change in Configuration

Relative to the pattern of the field shown in Fig. 8, another significant condition must be mentioned. This, the flattening of the facing lines of force as the consequence of the repulsion between them. While this may not have a great

meaning with respect to the actual action, the change in the configuration of the lines of force so that they run almost parallel to each other is a very important point.

At this stage, you may be wondering about the connection between the field as shown in Fig. 8 and what happens in the cathode-ray tube. The justification for showing the relationship between like charges is twofold. First, the type of configuration of the facing lines of force in Fig. 8 is a very close approach to what will be found in the cathode-ray-tube electrostatic focusing system. The second reason is to explain the background of the action whereby an electron moves away from a negatively-charged body. This could not be done very well using the field between two unlike charges.

On the whole, the field patterns in Figs. 5* and 8 serve well as background for the field patterns which will be found not only in the electrostatic focusing systems but also in the deflection systems.

Action of Charged Bodies

Expanding upon the basic conditions which we have described, it stands to reason that if a body or a surface is made to bear a preponderance of a charge of a single sign, that body will, in principle, display the same electrical effects as a single charge of the same sign. Of course, the magnitude of the effect will naturally be much greater, because there are many more charges present.

Therefore, if we arrange one surface to bear a preponderance of electrons and another to bear a preponderance of positive charges, and these two surfaces are placed so as to face each other, but are

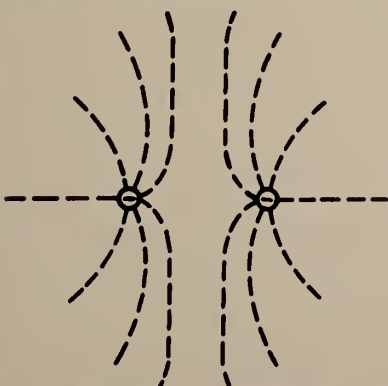

FIG. 7. Electrostatic field between two like charges.

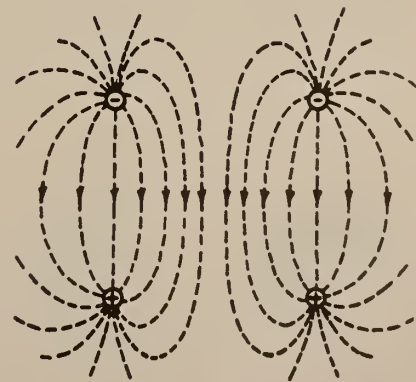

FIG. 8. Combined electrostatic field between like and unlike charges.

* The first installment appeared in IP for Dec., 1950, p. 26.
** 480 Canal St., New York 13, N. Y.

* IP for Feb., 1951, p. 25.

separated, an electrostatic field will exist between the two charged surfaces. The space between the surfaces will be filled with lines of force which will have a certain direction.

Such a system is shown in Fig. 9. The voltage source *B*, with an arbitrary difference of potential between its terminals, is connected to two parallel metal plates *A* and *C*. Prior to the application of the voltage, a condition of electrical equilibrium existed on the two plates; equal numbers of unlike charges resided on each of the plates, therefore, the space between the plates are devoid of any field.

When the voltage is applied, this two-plate "condenser," with air separation between, becomes "charged" like any ordinary electrical capacitor would.

One of the plates, *A*, bears a preponderance of positive charges and the other plate, *C*, bears a preponderance of negative charges by virtue of the polarity of the charging source; an electrostatic field is created between the plates and the space is filled with lines of force. In view of what was said earlier, we need not comment on the origin of the lines of force; if anything deserves comment, it is the configuration of this field as compared to the field between two unlike charges as previously illustrated.

Uniformity of Field

Between the plates, the field is made up of lines of force which are straight, and we may assume that they are uniformly distributed within the boundaries of the plates because the separation between the plates is small compared to the other dimensions of the surface.

If we neglect the conditions near the borders of the two plates, the number of lines of force penetrating any unit area of surface on the plates will be the same everywhere on the plate. Such a distribution of lines of force constitute a *uniform field*; this condition would not hold if the plates were not parallel.

As to why the lines of force which join the charges on the two plates are straight, rather than both straight and curved as shown in Fig. 5, that too is simple to explain. To begin with, charges made to reside upon a flat surface will

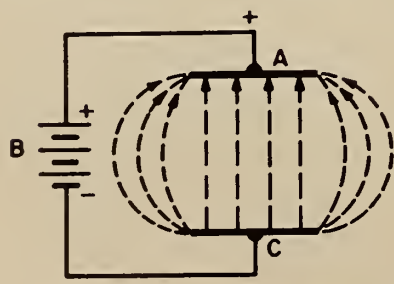

FIG. 9. Electrostatic field between two charged plates.

No Carbon Shortage in Sight Says National Carbon Co.

There is no carbon shortage in sight, according to National Carbon Co., in a statement directed at counteracting the ill effects of a news release appearing in the motion picture trade press under the dateline of March 2. This release called attention to a shortage of monazite sand as a raw material essential in the production of projector carbons, spotlamps and other equipment used in the motion picture industry.

National Carbon Co., quick to realize the trade disturbances that might be caused by such reports, states that in its opinion there will be an adequate supply of carbons in the foreseeable future, and that, as a consequence, there is no need for theaters and suppliers to overstock.

Last December, at the time of the issuance of copper conservation order M-12, National Carbon announced that an adequate supply of carbons was assured. Despite current reports at variance with this estimate, National Carbon sees no need for any change in its outlook.

normally distribute themselves uniformly over the surface. With large numbers of charges residing on each of the plates, there are many lines of force. Each of these, with the exception of the fringe at the boundaries of the plates, feels equal to repulsive forces all around it. With forces of equal magnitude tending to repel each line from all directions, the balancing of these forces leaves the line straight.

The curvature of the lines of force at the borders already has been explained in discussing the two charges of Fig. 5. These lines curve outward because the repelling force issuing from the area between the two plates exceeds the force which stems from the area on the outside of the lines. The result is outward curving lines of force. This non-uniform fringe field usually can be neglected.

Regarding the direction of the field, we follow the previous convention, namely, that direction as would be defined by its action upon an electron. Therefore, the line of force points away from the negatively-charged plate and toward the positively-charged plate.

Energy of the Field

Several very interesting and important observations can be made about such an electrostatic field. First, the creation of it requires work, or energy, because the separation of negative charges from positive charges is accomplished only by the application of some force. Moreover, as more and more electrons are re-

moved, the attractive force of the remaining charges upon the electrons becomes greater and greater.

In like manner, the accumulation of electrons on the other plate also becomes increasingly difficult, since like charges repel; therefore, force must be exerted to push these negative charges onto the so-called negative plate. As more and more electrons are piled onto this plate, the repulsive force naturally increases and must be overcome in order to push more electrons onto that surface. In short, *work must be done upon these electrons in order to get them to redistribute themselves in this manner.*

Bearing in mind that these electrons were initially at rest, some source must impart energy to them so as to cause them to move around through the circuit in a specific manner and specific direction—against the natural forces which either bind them to each other or tend to make them repel each other, depending upon the polarity of the charges.

Source of Energy

This function of supplying energy to the electrons is performed by the device which "charges" the system. In Fig. 9 this is the battery *B* which can be replaced by a voltage source of some other type, such as a vacuum tube or a generator, without altering the basic phenomena. The voltage source introduces the initial *difference of potential* or *electromotive force* (emf), which exists between its terminals, necessary to make the electrons move around the circuit.

As the negative charges are transferred from one plate to the other, they convey energy and gradually establish a corresponding difference of potential between the plates themselves. The energy which the voltage supply imparted to the electron is transferred to the electrostatic field (between the plates) when the electron comes to rest. Therefore, we can view the difference of potential between the two parallel facing surfaces as representing the capabilities of the electrostatic field to make electrons move, just as the initial difference of potential between the terminals of the voltage source enabled electrons to move through the system initially.

The electrostatic field between the plates can make electrons move either between the plates, or through a conductor which joins the two plates. The limit of movement of the negative charges under the influence of the original voltage source is reached when the difference of potential established between the plates equal the difference of potential between the terminals of the battery. At this time, the magnitude of the attractive force of the positive charges on the positive plate and the magnitude of re-

(Continued on page 26)

Variable Shutters in 16-mm Filming

By JOHN FORBES

PERHAPS the least understood feature of the cine camera is the shutter. How it functions, what its effect is on the exposure, and the comparative results to be obtained with shutters of various size openings is something that is rarely considered by the novice cinefilmer. But to the advanced 16-mm movie maker all this is quite important, even though his camera may only feature a shutter of the fixed type.

Briefly, when we expose a frame of cine film, the film is held motionless in the camera for a fraction of a second. Before the next frame can be exposed, the film must be advanced in the gate in order to bring an unexposed frame in place for the next exposure. During this advance of the film, the light coming through the lens must be cut off momentarily, and this is the function of the shutter.

Rotary Disc Type Shutter

In most 16-mm cameras the shutter is of the rotary disc type. Part of the disc is cut away to permit the passage of light to the film for the exposure. The disc shutter rotates continuously as the camera is operated.

Obviously, the larger the opening of the shutter, the more light reaches each frame of film and, consequently, the greater is the period of exposure. But there are some definitely limiting factors. Most important of these is the mechanical problem of moving the film.

During the period between the exposure of two successive frames (that is, the time period during which the shutter is "closed"), the film must be started, moved—then stopped dead. Clearly, if the open part of the shutter is large, the film must accelerate, move and decelerate very quickly. If the open sector of the shutter is smaller, the film can be moved more slowly and, accordingly, more gently. But we pay for this less strenuous movement by getting less light for the exposure.

Varying Exposure Times

What has all this to do with ordinary camerawork, you may ask, remembering, of course, that changing speeds and shutter openings are possible only with a few cine cameras. Well, to explain further, suppose we have an ordinary still camera and the established exposure for a given shot is F:8 at 1/25 second. If we shorten the exposure time to 1/50 second, we will have to open up the lens a corresponding amount—to

F:5.6—in order to secure the same exposure.

It's the same in cine camera work. Suppose we are using one of the popular cine cameras which has a shutter opening of 204°. This gives an exposure interval of 1/27 second at 16 frames per second. If we shoot a scene with this camera and find that F:8 is the right stop to use, the resultant exposure will be different from what another cine photographer would secure with a camera having a smaller shutter opening.

Let's say the other photographer's camera has a shutter giving a 1/48-second exposure. If he is to match our exposure on the scene, he will have to shoot it at F:6.7 (or lens stop nearest this figure, i.e. F:6.3). If we, with our 1/27-second shutter, are shooting at F:2.5, the other filmer will have to open up to F/1.9 to get comparable results; and if we are shooting at F:1.9, the other fellow with the faster shutter (giving less exposure per interval) won't be able to shoot the scene successfully at all, for he would have to use a lens opening of F:1.1 to match our exposure.

Greater Depth of Focus

Another point to consider is that by using the smaller lens stop, the lens will have much greater depth of focus than would the lens on a camera with a smaller shutter opening; and this difference would be increasingly noticeable as the lens was opened wider or focused on nearer objects, as for closeups.

On the other hand, in the matter of getting clear pictures of fast-moving objects, the camera with the smaller shutter opening offers a distinct advantage. It affords a shorter exposure interval, and this in turn means that fast-moving objects will have less time to move during an exposure, and consequently less blur will result.

Adjust for Every Shot

Obviously, the solution to the shutter problem for the advanced amateur's cine camera is the adjustable shutter, same

as found on standard 35-mm motion picture cameras. This would permit adjusting the shutter opening to suit the shot. All professional 35-mm cameras used in the studios have variable shutters, and most of them allow adjusting the shutter opening while the camera is running, if necessary. This has proven a very valuable adjunct in shooting scenes where the camera moves in and out of dark areas, or for trick effects where speed of a person or an object is to be altered without stopping the camera.

Of the 16-mm cine cameras in popular use today, two are provided with variable shutters, adjusted manually by the operator—the Eastman Cine-Kodak Special and the Pathe "Super 16." This feature has been used mainly for making fades and lap dissolves, but it presents other cinematic possibilities also.

Here are some of the ways 16-mm cinefilmmers may benefit their cinematography by varying the shutter opening—ways that the professional cinematographer long ago employed to improve the quality of his camera work:

Fades and Lap-Dissolves

Most obvious, of course, is the making of fades and lap-dissolves. This in itself justifies the variable shutter as standard equipment on the advanced amateur's cine camera.

Next, and much more important, is the control of exposure without altering lens setting. Remember, reducing the lens opening increases depth of focus, and increasing the aperture size reduces depth. Such changes between closely related scenes are not pleasing; and when light fluctuations, such as a cloud passing over the sun, for example, make such changes necessary within a scene, they are doubly objectionable. By controlling the light with the shutter, such depth of focus contrasts can be avoided.

If, for instance, we refer to the chart on page 144 of the new 1950 edition of the *American Cinematographer Handbook*, we see that if we are shooting on one of those days, say, when small clouds are obscuring the sun, we can set our lens at, say, F:8.3 and the shutter at 90° and get the same exposure as though we shot at F:11.3 with the shutter opened to 170°. With cameras having a variable shutter, when a cloud suddenly appears to reduce the light falling on the scene, the exposure can be kept uniform (in

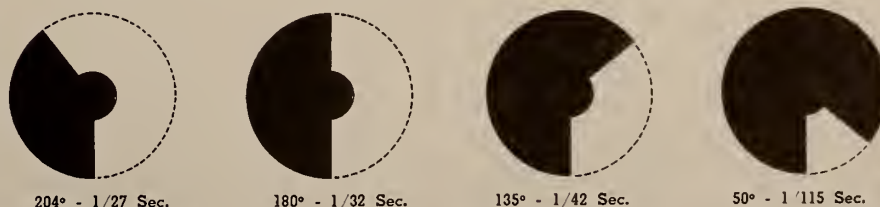

Relative exposure intervals afforded by camera shutters of various size. The smaller the shutter opening, the faster the shutter "speed," with greater ability to "stop" action.

relation to preceding shots) by simply opening the shutter to a wider aperture. If the clouded light would be a normal F:8.3, all we need to do is open the shutter to 170° and we get the effect of increasing the exposure to the proper value without changing quality of our picture.

The same procedure may be followed in panoraming and in making moving camera (follow) shots. Suppose we are following a person with the camera, walking from bright sunlight into heavy shade. Let's say there is a good three-stops difference in the exposures between the lightest and darkest areas of the scene. We can begin the sunlit end of the shot with the camera lens open three stops wider than normal—say,

F:5.6—and the shutter closed down to about 50°. As our subject moves into the shade, the shutter is opened up to an aperture of 170°.

Uniform Exposure, Quality

Throughout the shot, both exposure and quality of picture will be uniform, for we offset the changing light by increasing exposure time from 1/115 to 1/34 second. The same expedient will also prove useful in super-speed "slow-motion" shots, as well as in making undercranked fast-action scenes.

Finally, the controllable (variable) shutter will prove its worth in scenes of fast moving action. By reducing size of the shutter aperture, exposure time is cut, resulting in crisp, blurless pictures.

million. This standard was based on a number of considerations, and, from present information available, it would seem that if it is in error it errs on the safe side.

So far as we know, there are no standard methods at present for the determination of the concentration of dioxane in the air. Two or three methods have been suggested, but we do not know whether determinations have been made, or if so, what methods have been used for this purpose in industrial establishments.

Conclusive Evidence Lacking

If I were going to take a position as an editor on this subject, I would want better evidence than any I have given you in this letter, or any that are available to us at this time. It would seem that the facts could be established by the examination of the conditions under which men work, and also by the examination of the men so exposed. I have no wish or intention of condoning conditions that are unsatisfactory, but I cannot but feel that there is no substitute for facts as a basis for expressing an opinion on this subject.

ROBERT A. KEHOE, M.D.

Dept. of Preventive Medicine and Industrial Health, University of Cincinnati.



The appended communication from a recognized authority in his field is noteworthy in view of the repeated assurances by the manufacturers of film cements that they do not use dioxane in their preparations.—Ed.

TO THE EDITOR OF IP:

I am afraid our efforts have been of very little avail in giving you any real answers to your questions. First . . . we do not know anything of practices of the trade in this respect, nor do we know of any observations that have been made that would indicate the nature of the solvents used, the concentration of dioxane therein, and the concentration of dioxane and/or other solvents vapors in the atmosphere of projection rooms. In the absence of such information, anything . . . said on the subject is pure guesswork. Therefore . . . before anybody says anything about this subject pro or con, some observations that would establish the facts should be made. It is entirely conceivable that there are dangers, and therefore the situation merits investigation.

Wide Variance of Opinion

With specific reference to the toxicity of dioxane and the probable effects, there is some disagreement. Yant and his associates concluded from their experiments that dioxane had a low order of toxicity, and pointed out that men could be exposed to air containing 1000 parts per million of the vapor of this solvent without discomfort.

The latter does not mean, however, that persons exposed over a long period of time to low concentrations will not suffer some injury. Without necessarily contradicting the observations and opinions of Yant, other observers have

described effects which they believe to be those of insidious, more or less chronic, effects, associated with prolonged exposure.

The toxicity of the material in low concentration in the atmosphere has not been investigated sufficiently to enable one to establish soundly a differentiation between safe and unsafe concentrations in the air. Various states, acting on information available at the time of their adoptions of a standard, have set standards which vary all the way from 1000 parts per million to 100 parts per million. Aside from governmental agencies, I know of no body of professional men that has adopted a standard, other than the American Conference of Governmental Hygienists.

'Allowable' Concentrations

This group, of course, is made up largely of men representing official agencies. They have adopted the maximum allowable concentration of 100 parts per

IA-IP Amateur Radio Contest Data Deferred for a Month

Publication of the outcome of the recent IA-IP amateur radio contest, scheduled for this issue, will have to be deferred for another month due to the unfortunate circumstance which occasioned the loss of the final tally in transit from Amos Kanaga in California. It was hoped right up to the last minute that a new tally could be prepared in time, but inevitably the deadline arrived and had to be met.

Fortunately, Amos retained his original work sheets, thus he will be able to replace the lost data. He promises faithfully to have them on tap in ample time for the next issue of IP.

Projection Tidbits From the Foreign Field

Herewith are several interesting items culled from the foreign film trade press. From *Sight and Sound*, Australia: The manager of a suburban theater pleaded guilty to a breach of the Cinematograph Regulations in that he had employed regularly each day a projectionist who was licensed to operate only as an "assistant" two nights each week.

In imposing a fine of \$50 on the manager, the judge commented: "The regulations are specific, and the obligation is on the employer to see that the projectionist is properly licensed. The important factor here is that public safety is involved."

A Projectionist's Prerogative

In the same journal is the account of how a projectionist ran a Technicolor print for one night only and then refused to run it thereafter on the ground that it was "unsuitable for exhibition" because of its poor physical condition. The second evening's show was cancelled and admissions were refunded. The projectionist was upheld by both his Union and by the law covering motion picture exhibitions, which provides that the projectionist may, when he deems fit, refuse to run any print which he considers in poor physical condition.

In *Ideal Kinema*, of London, editor R. H. Cricks offers this item: A Cinecolor

print marked SAFETY FILM contained about 50 splices, several of which were remade with non-flam cement. After the first showing all remake splices came apart. All splices were then remade with nitrate-film cement, and gave no further trouble. A test with a lighted match disclosed that the film stock was nitrate. The distributor reported that the film was *not* safety stock, as the words SAFETY FILM were not printed in black lettering.

Laboratory is Held at Fault

Comments editor Cricks: "A test with a match confirms that the stock is not safety—anyway, the edge-printing of all film stocks is, of course, in black lettering, not white-on-black. It is clear that one of the two negatives from which this copy was printed—the blue printer—was on safety base, and that in blackening the margin of the positive the words SAFETY FILM have printed through.

"I hasten to add that one should not unduly blame Cinecolor for this fault, for it is a common practice in many laboratories to print the edges of the film in order to print through the edge numbers from the negative. But if safety films are being used for negatives or for laboratory films, it is a practice that must stop."

Warner Bros. Dissolution Terms

Warner stockholders will receive a half share in the new theater company and a half share of the new picture company for each share of Warner stock held of record when the reorganization becomes effective on or before April 4, 1953.

Assets of the new theater company will include all Warner theater assets in the U. S., represented by investments in and advances to subsidiaries, and sufficient cash and Government securities in order that the consolidated balance sheet of the new theater company and its subsidiaries will reflect a ratio of not less than 1½-to-one of current assets to current liabilities.

Holdings Total 436 Theaters

Warners, through its theater subsidiaries which are more than 99% owned, has 436 theaters consisting of 236 houses owned in fee, 191 leased theaters and nine theaters partly owned and partly leased. Of these, 20 are presently closed, seven are leased or sublet to a 50%-owned subsidiary, and three are leased or sublet to others.

Under the consent judgment, Warners or the new theater company must, within two years, divest itself of 54 theaters, of which half must be divested within one year. Divestiture of up to 27 additional theaters may be required upon the hap-

pening of contingencies described in the judgment.

Warner will transfer to the new picture company all production and distribution assets and all other assets not transferred to the new theater company.

1950 Admissions Tax Off 7%

U. S. motion picture theaters grossed an approximate \$1,320,000,000 last year, about 7% under the \$1,430,000,000 grossed in 1949, it is estimated on the basis of Internal Revenue Bureau reports of admissions tax collections against the 20% levy. IRB reported that its January collections, which reflect December admissions, totaled \$26,856,033 for general admissions. Figure compares with \$27,909,723 for the same period of last year.

General admissions collections reported for the 12 months of 1950 total \$347,390,757, with approximately 76% of this figure estimated to come from film theaters. In 1949, the collections totaled \$374,374,696.

RCA Promotes Jack O'Brien

J. F. (Jack) O'Brien has been appointed sales manager of RCA theatre film recording, visual, and sound equipment. In charge of theatre equipment sales since 1946, O'Brien succeeds Barton Kreuzer, promoted recently to manager of the administration division of RCA engineering products. O'Brien with RCA since 1931, when he started as a representative in the company's national credit department, has held important



sales posts for engineering products in Hollywood, Indianapolis, St. Louis, Chicago, and Boston. His activities in theatre equipment sales during the past 20 years have made him nationally known in theatre circles.

O'Brien, a native of Buffalo, N. Y., is a graduate of New York U. He is a member of the Variety Club of America, and has been active in the affairs of such organizations as the SMPTE, TESMA, and the TOA. He resides in Audubon, N. J.

RCA Theater-Tv Price Slash

BIGGEST shot in the arm for theater television since its inception was administered early this month when RCA announced a reduction in price of its PT-100 theater Tv system from \$25,000 to \$15,800. The former high price tag has encountered terrific exhibitor opposition; although some trade circles viewed the RCA move as an anticipatory counter to expected activity by 20th Century-Fox with the Eidophore (Swiss) large-screen Tv system for which it recently closed a deal.

The reasons for the RCA move at this time are relatively unimportant by comparison with its tremendous implications anent the future of the motion picture theater, with the expansion of the art now lying squarely on Mr. Exhibitor's doorstep. One trade reaction is that 1951 may see the installation of an additional 150 to 200 Tv systems in theaters.

No Parts Shortage at Present

RCA declared that it is proceeding with full-scale production of the PT-100 system, with the "standardized picture tube and other electron tubes and components it employs being readily available" at this time. PT-100 circuits are so designed that a minor adjustment will permit operation with higher picture definition if standards permitting such definition should be adopted for closed-circuit theater Tv.

Most recent proof of the boxoffice draw of the instantaneous theatre television now available, pointed out RCA, was the capacity audience of 4000 which jammed Fabian's Palace Theatre in Albany on Tuesday night, February 20, to see the Sienna College-Georgetown University basketball game being played before an on-the-scene audience of only 2500 in the Uline Arena in Washington, D. C. This attendance was chalked up despite the fact that it was the last night in the run of the feature motion picture currently being shown.

Modify Aluminum Scrap Order

NPA's aluminum scrap order has been amended to postpone the effective date of certain provisions until April 1 in order to permit the inclusion of additional firms to process aluminum scrap. As originally issued, the order (M-22) designated, on the basis of experience and technical resources, certain fabricators and smelters as authorized to process scrap. Since the order was issued, it has developed that the list is incomplete and there are firms not included in the original list who may well be qualified to continue to process scrap.

The order provides that qualified firms will be included, and pending completion of the further review scheduled by April 1, there is no limitation on concerns presently processing scrap. At the same time the

order was also amended to allow foundries, certain types of chemical firms and others to obtain special kinds of scrap for use in the regular course of their operations.

U.S. Exports to India Remain Strong

The preeminent position of the United States in the film export market, despite exchange restrictions, is emphasized by a recent report in India's *Journal of the Film Industry* giving statistics pertaining to import licenses from July through November,

1950. Licenses for film equipment and accessories valued at 1,048,127 rupees were issued, allocated as follows:

Approximately 804,400 was for U. S. equipment, 91,653 for German apparatus, 51,198 for British, 50,438 for Italian, and 50,438 for Swiss. Licenses for raw films valued at 66,775 rupees were issued, *all of it* for British rawstock. Import licenses for motion picture carbons totaled 411,922 rupees, of which 244,519 was for British carbons, 76,659 for United States products, 57,209 for French carbons, and 33,535 for Italian carbons (4.76 rupees equal U. S. \$1).

Extract from Committee Report

SUMMARY OF PROCEEDINGS

MID-CENTURY CONVENTION

THEATRE OWNERS OF AMERICA, Inc.

"We recommend that you examine your equipment closely and that equipment in which you cannot see at least a three year expectancy of satisfactory service be replaced or repaired. Already there is a growing shortage among certain parts; however, let us not create our own shortages by hoarding."

Where Theatre
Modernization Begins!

NATIONAL

THEATRE SUPPLY

Division of National • Simplex • Bludworth, Inc.

"World's Most Powerful Spotlight"

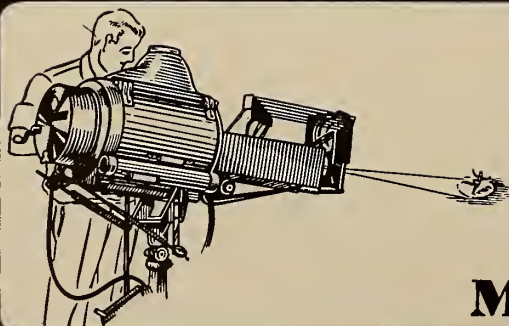

The METRO-LITE high-intensity carbon arc spotlight comes in two models:—

- ★ MODEL ME 4 125 Amps D.C.
100 ft. to 400 ft. throw.
- ★ MODEL ME 5 "Vaudeville"
60 to 85 Amps D.C.
75 ft. to 250 ft. throw.

METRO-LITE

Literature available on both units upon request to
GENARCO, Inc. 36-56 b 34th St., Long Island City 6, N. Y.

PERSONNEL

ROBERT P. YOUNG has been named manager of professional motion picture sales by Anasco, succeeding J. KNEELAND NUNAN. Young, who joined the company in 1945, will headquarter in Hollywood.

E. T. PICKARD, JR., commercial assistant to the manager of Westrex Corp.'s subsidiary in the Philippines, has returned to New York headquarters for assignment to the radio department of Westrex.

JOSEPH T. GOLAN has been named superintendent of the cine and sheet film division of Eastman Kodak's Rochester plant, succeeding HENRY T. IRELAND, who has retired after 43 years with the company. DAVID A. BABCOCK, superintendent of the Kodak emulsion coating department, retired on March 1 after 45 years of service.

10½ Million Tv Sets Now in U.S.

Total number of Tv sets in the U. S. is now 10,549,500, with a gain of 704,200 sets during last December, reports an NBC survey. Set sales during 1950 totaled 6,000,600, indicating that three out of every five families bought their set during 1950.

Every fourth family in the U. S. now owns a Tv set, states the survey, and two out of five families living in the Tv service area have the set in their homes. New York leads with 2,050,000 Tv families, while Chicago has 830,000.

Century Units Into Eastman House

Century 35-mm projectors, water-cooled, and sound system have been installed at George Eastman House in Rochester, N. Y., home of a world-famous collection of historical photographic equipment and data. Incidentally, the projection at G. E. H. is masked with mauve velour.

CATHODE-RAY TUBE DATA

(Continued from page 22)

pulsive force of the negative charges on the negative plate are sufficient to offset the electromotive force (emf) represented by the difference of potential, or voltage, of the battery.

Build-Up of Potential

The time required for the difference of potential between plates *A* and *C* to rise to the value of the voltage source *B* is a variable depending upon several factors. None of these are of interest in connection with the systems used in cathode-ray tubes, whose operation is now being explained.

Practically, we can assume an instantaneous rise in potential, between the plates, to that of the voltage source *B*. Of course, there always will be some

time lag, but this is so slight from the usual practical viewpoint that it can be neglected over any range of frequencies presently encountered in cathode-ray tube applications.

The development of a detectable electrostatic field between the plates, or the setting up of lines of force between the plates, commences with the first electron which is transported, and the field becomes increasingly stronger (greater number of lines of force) as more and more electrons are removed from the positive plate and added to the negative plate.

The ability of the electrons, accumulated on the negative plate, to hurdle the gap separating the plates is strictly a function of the intensity of the field; this, in turn, is a function of the amount of energy which is given the electrons by the so-called "charging" voltage source.

If this voltage were gradually increased from zero, a value would be reached when so many electrons had been redistributed that the mutual attraction between the positive charges on one plate and the electrons on the other plate would literally tear away the electrons from the negative surface, in a direction along the lines of force, and a "current" would flash across the gap. This current, or spark, would be momentary of course, but would nevertheless dissipate the entire field.

A phenomenon of this type is an example of *work being done on the electron*, the action being across the space between the plates rather than through any metallic conducting path around the plates. Since it is possible for the field to exert sufficient force upon the electrons on the negative plate so as to pull them to the positive plate, it stands to reason that if electrons were positioned between the plates they could be acted upon in similar manner.

The motion of these space electrons would be governed by the forces present in the field, which in turn would correspond to the field intensity at the point where the electrons were located. This leads to the description of the field from the viewpoint of the forces present at various points in the field.

Forces Acting on Spatial Electrons

Let us use, as the basis of our discussion, the illustration in Fig. 10. This shows a uniform field existing between two parallel plates. We shall locate three electrons, *a*, *b*, and *c*, at three different points in the field. One of them, *a*, will be near the negatively charged plate; electron *b* will be midway between the two charged plates, and electron *c* will be near the positively-charged plate.

All of them will feel the same pull toward the positive plate because of the direction of the field, and, what is more,

NOW!
f/1.9
EVEN IN 7 INCH FOCAL LENGTH!

for the
LATEST PROJECTORS!

The newest projectors can take larger lenses. Here is the lens designed specifically to achieve top performance with these modern projectors — the sensational *four inch diameter Super Snaplite*. Speed of *f/1.9* from 5 through 7 inch focal lengths, in $\frac{1}{4}$ inch steps.

MORE LIGHT...the four inch diameter Super Snaplite gives you an *f/1.9* lens in focal lengths as long as 7 inches!

LONG LIFE...one piece mount, specially sealed lens elements, anodized finish that can't flake off — all spell longer, top-notch performance for the four inch diameter Super Snaplite!

SHARPER PICTURES...a true anastigmat lens for longer throws — the four inch diameter Super Snaplite produces pictures wire-sharp right to the very corners!

HIGHER CONTRAST...anti-reflection coatings further enhance the brilliant, crisp, sparkling pictures projected by the four inch diameter Super Snaplite!

Four inch diameter Super Snaplites are available, to order, in focal lengths from five up through seven inches, in quarter inch steps. In all these focal lengths the true effective speed of *f/1.9* is maintained. Four inch diameter Super Snaplites are also available, to special order, in focal lengths longer than seven inches, at somewhat slower speeds.



Get the full facts of this superlative new lens now—write for your copy of Bulletin No. 209 today!

"You Get the Most Uniform Light with Super Snaplite"

KOLLMORGEN
2 Franklin Avenue
Brooklyn 11, New York

Optical CORPORATION

all of them will experience the same force making them move to the positive plate. Naturally, all will advance along lines of force.

The movement of the electrons is not due solely to the attraction by the positively charged plate, *A*. A distinct contribution to this action is made by the negatively-charged plate as well. During the time that the positively-charged plate is *attracting* the electron, the negatively-charged plate is *repelling* the electron toward the positive plate. Hence two forces, in the same direction, are acting upon the charge.

If we imagine the electron located midway between the plates, in this case electron *b*, equal forces of attraction and repulsion will move the charge in a single direction, i.e., toward plate *A*. The total force moving the electron will be the sum of these two individual forces, both, you will remember, acting simultaneously in the same direction.

Magnitude of Opposing Forces

If the location of the electron is changed so that it is no longer midway between the plates but near the negatively-charged plate, like electron *a*, the total force acting upon the electron still will be the same as before. Although it

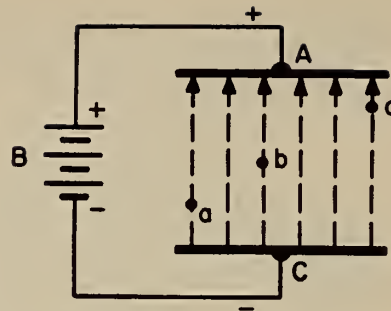

FIG. 10. Electrons placed in electrostatic field between two charged plates and acted upon by force of the field.

is true that the magnitude of attracting force has been decreased due to the greater separation between the charge and the positive plate, the magnitude of the repelling force has been correspondingly increased due to the greater proximity of the electron to the negative plate, thus maintaining the total force constant.

Reversing the location of the electron—that is, locating it near the positively charged plate *A*, as in the case of electron *c*—does not change the force acting on the electron. The reduction of repelling force due to the increased separation between the charge and the negatively-charged plate is compensated for

by the corresponding increase in attractive force from the closer positively-charged plate.

Thus it is understandable, even without a mathematical analysis, that the electrostatic field acting upon the electron anywhere within such a uniform field is constant. This holds true for any one set of conditions which establish the magnitude of the field and for any one set of plates separated by a fixed distance.

The actual force in dynes experienced by the electron is of no consequence in this discussion. It can be small or it can be great, depending upon the difference of potential between the plates *A* and *C*. The important detail to bear in mind is the direction in which the force acts, and that the force is constant throughout the field.

"ARTIC BLANCH"
Snow White
THE DEPENDABLE SCREEN COATING
for
DRIVE-IN THEATRES
NATIONAL THEATRE SCREEN
REFINISHING CO.
129 ZENNER ST. BUFFALO 11, N. Y.

Old Type Lens

B&L Super Cinephor Lenses

44% to 100% Brighter

NOW, more than ever

HOLD your patronage with the

WORLD'S FINEST SCREEN IMAGE!

Replace NOW . . . for steady patronage . . . steady profits . . . with B&L Super Cinephor Lenses

Get large, vivid screen images! They're your best competitive advantage over any other type of entertainment. Your patrons will keep coming back to see the sharp, brilliant images of today's fine films . . . the edge-to-edge contrast and definition . . . the superb image quality . . . that you get with B&L lenses.



Write for complete information to Bausch & Lomb Optical Co., 616-3 St. Paul Street, Rochester 2, N.Y.



Bausch & Lomb

Super Cinephor Projection Lenses

EFFECTS OF TV ON THE MOTION PICTURE THEATER

(Continued from page 17)

ment must, of course, be adaptable to existing theaters. In a survey of about 600 U.S. theaters, conducted by the SMPTE in 1938, an average screen width of 18 ft., 6 in. and an average ratio of maximum viewing distance to picture width of 5.2 was found.

An increase of average screen width to 24 ft. 0 in. would reduce the ratio of maximum viewing distance to picture width from 5.2 to 4.0 and would increase the screen area by about 67%. This change would be structurally feasible in the majority of existing theaters. It is true that in many of the existing theaters, the use of several of the front rows would be eliminated, but the seat loss would be nominal.

Elimination of Screen Masking

With reference to the elimination of black screen masking, observations by acknowledged authorities since 1920 have indicated the desirability of illumination of screen surroundings. The most desirable contiguous brightness has been found in practice to be the synchronous type which automatically varies with the brightness of the picture.

Some of the many examples of this type are the Island Theater, Bermuda; Crown Theater, New Haven; Essoldo Theater, Penge, England; and the Tacna Theater, Lima, Peru. Further developments and refinements for providing a synchronous luminous screen surround have been incorporated into several theaters now under construction, including the Shopping Center Theater in Framingham, Mass., and the Bellmore Theater, Bellmore, L. I.

Theater Location Trend

New motion picture theater construction in the U.S. has not been proportional with the increase of population. The growth of television is probably one of the factors which accounts for this. However, new population centers and obsolescence of theaters, both in plant and location, do create a demand for new theaters. Several recent developments have greatly affected the location and seating capacity of new theaters.

Since 1945, new residential planning has tended to be in the form of large-

scale, integrated communities very often decentralized. Shopping and night-life centers are then located either within the new communities or on the periphery adjacent to highways.

The necessities for parking areas then become a major consideration in theater location. With high land values, it is difficult for new theaters in existing urban night-life centers to provide adequate parking facilities. There has, therefore, been a tendency to locate new theaters within the confines of the new

communities or in the shopping centers.

When new theaters are located within the confines of new communities, they have the ease of accessibility of the neighborhood theater. The architectural planning of residential projects very often indicates the use of several smaller theaters, with capacities in the order of 400 to 600 seats, rather than a single large theater.

Smaller Theaters Desirable

The smaller theaters have fewer building code restrictions and are more eco-

Protect the HEART of your theatre with RCA Service...

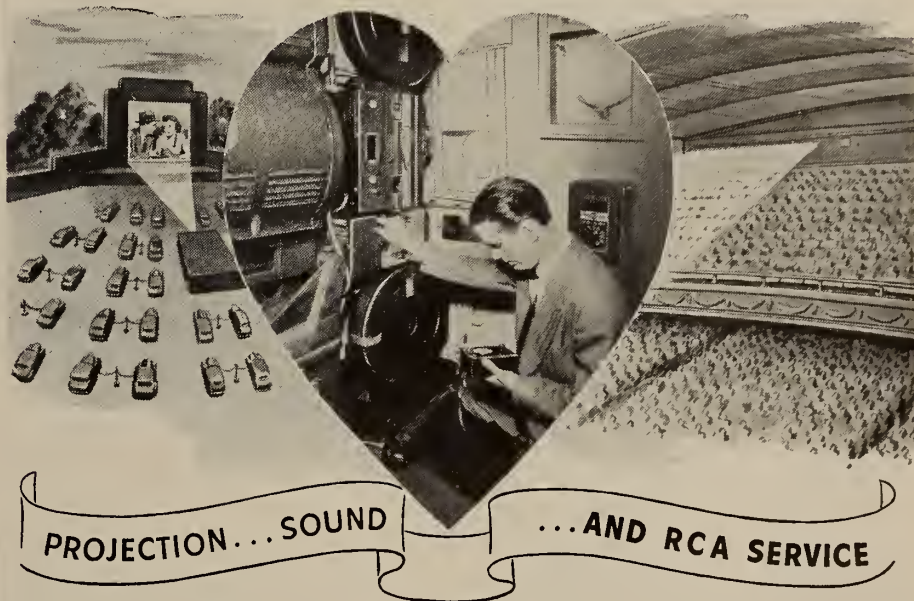

The possible scarcity of new equipment makes it doubly important today that you safeguard and conserve your projection room equipment—the heart of your theatre. So, for top performance security, be sure your theatre is protected with an RCA Comprehensive Parts and Repair Plan.

It costs so little to protect so much

The advantages of RCA Service are yours at a cost so low, a few admissions daily pay for it. Write for FREE folder—"Performance Security."



RCA Service and Parts Plans cover all makes and types of theatre sound equipment, as well as motion picture projectors and accessory units.

RCA Service averts breakdowns and assures you of the ultimate in performance security. But if a theatre needs emergency service it is available 24 hours every day.

For drive-in theatres... in addition to a preventive maintenance plan for projection equipment... RCA has a replacement and repair plan on RCA In-car Speakers and Junction Boxes.

Take Care of Your Prints

Gradual conversion to magnetic films for original sound recording should reduce somewhat the demand for fine-grain sound recording stocks. The synchronous 1/4-inch tape systems should help even more, for they don't require consumption of motion picture film base. But since release films represent by far the largest share of the industry's production, there is the place to save.



RCA SERVICE COMPANY, INC.

**A RADIO CORPORATION of AMERICA SUBSIDIARY
CAMDEN, NEW JERSEY**

nomical in per-seat-cost of construction. Their scale suggests simplicity of exterior treatment and amenities. They do have the virtue of intimacy within the interior of the theater and can achieve to the greatest degree the previous suggestions as to screen size and treatment. All of the seats can approximate the "ringside" seat.

Availability of screen product and allocation of runs to groups of smaller theaters is an industry policy question of great importance.

The location of theaters within new large-scale shopping centers has different aspects. Adequate parking facilities are available, the theater plays an important part in building up night activity, and there is, generally, considerable

transient automobile traffic. This indicates a larger capacity theater.

To achieve intimacy in the larger theater is an architectural challenge. Reduction of the interior volume of the auditorium to a minimum helps to create acoustical intimacy. Screen size is, of course, increased in the larger theater, and with it, the scale of the screen surround treatment is increased. This enhances the visual intimacy which is the prime consideration. Then, the shaping of walls and ceiling, the avoidance of decoration which gives scale "measuring rods" and the integration of interior lighting must attempt to approach intimacy of space.

Now and existing theaters which offer to the public the seating, air condition-

ing, projection and sound transmission comforts, which are now available, and which add to these the increased screen image, the luminous screen field, the increased flexibility and scope of motion picture cinematography, the feelings of intimacy within the auditorium, and stereoscopy of sound and vision, should survive within the forests of home television antennae which have become a feature of the skyline.

Discussion:

PIERRE MERTZ: Some years ago, there was a development in films which seemed to cover something of what Mr. Schlanger had in mind with regard to the wide screen—the Grandeur film. That occurred before I came into this field. Can you tell us, what was the improvement in realism with the Grandeur film as compared with the conventional film?

MR. SCHLANGER: There are many factors involved. First, there was a larger physical width of film, and I believe since then the film grain problem has been more or less licked and that a sufficiently large picture can be projected from 35-mm width.

Present Screen Size Ample

The present standard gives a wide enough picture in theaters, and the real problem, which was not licked at the time that Grandeur and other wide, enlarged screens were presented, was the cinematographic problem. It is quite natural. It was a new tool and it never had its chance for the experience or practice that is needed with a new tool. In other words, the cinematographers never became familiar with the new tool or its potentials at that time.

Today we are in a spot where we know we need some new method or device, and should we find it, the cinematographers will learn to use it.

As to the realism that can be achieved, there is another problem in addition to that of the size of film and the art of cinematography—that is the taking-lens in the camera. I remember getting in touch with some of the authorities and manufacturers of lenses to try to find out why there were not wider-angle lenses available or used in taking motion pictures, and the significant answer was that there was never any great demand for them. But it was possible to develop them. I do hope that they will develop wider-angle lenses, because that is another tool in the flexibility of cinematography that is necessary.

Drive-ins vs. Auditoriums

FREDERICK J. KOLB, JR.: Most of the desirable features of theater design that you have discussed seem directly contrary to the requirements of a drive-in theater. Is it possible to reconcile the two?

MR. SCHLANGER: Would you be specific as to their being contrary?

DR. KOLB: I am thinking of the drive-in theater as having a very limited angle of view—more like the home television viewing conditions. Therefore, the advantage to be gained by including a larger story element on the screen and by restricting the

ONLY
Century **PROJECTORS**
HAVE EVERYTHING



4-inch diam. lens mount

Water-cooled apertures

Oil-less Bearings

CENTURY'S high-efficiency projector with the NEW 4-inch diam. lens provides pictures of increased brightness and appeal—for even the largest drive-in screens.

CENTURY'S water-cooled aperture gives as much light with a 90 ampere arc as other projectors using a 180 ampere arc and heat filters!—Reduce power cost—Get sharper pictures—Save film.

CENTURY'S sealed, oil-less bearings and glass-hard gears reduce maintenance costs. No oil sprays or baths to mess up film or projection room.

You can SEE and HEAR the difference!

CENTURY PROJECTION AND SOUND SYSTEMS
See your dealer or write for information

CENTURY PROJECTOR CORPORATION *Century*
New York, N. Y.

NEVER HAS
Economy
BEEN SO
ESSENTIAL AS NOW!

SLOW BURNING
SAVINGS IN POWER CONSUMPTION
SAVINGS IN MAINTENANCE

ECONOMIZE
WITH *Lorraine*
Carbons

Lorraine CARBONS, INC., BOONTON, N. J.

THERE IS A LORRAINE CARBON TAILORED FOR YOUR SPECIFIC PROJECTION REQUIREMENT
Send necessary projection equipment data to guide us in recommending the Lorraine Carbons that will do your theatre or drive-in projection job better and More Economically.

audience to the most favorable locations seems very difficult—at least, to me—to realize in drive-in design.

MR. SCHLANGER: In drive-in theaters, the remote car positions are at least 10 W [W = screen width]. They are placed so because of the physical problem of getting enough attendance with one screen, and I have noticed that there have been some developments recently for double screens and even four screens. I guess that is one of the problems to be overcome.

From a 10 W location in a drive-in theater, the picture looks like a postage stamp. It is not that it is poorly done. It is an inconspicuous speck in the field of view. However, the drive-in theater is a unique experience—to be able to ride out in your car and go and view a picture is still “something different.” The audience will tolerate a lot when a thing is unique enough.

‘Unique’ Angle of Home Tv

For example, even home television, good as it is today, falls far short of the quality of a motion picture in a theater. But it is tolerated; it is considered all right because it is unique. You can sit in your slippers,

smoke a cigar and watch television without leaving your house.

Getting back to your question—can you produce a picture which is just as useful in a drive-in theater as in any other theater? There is an inconsistency in this respect and it can be related also to television viewing. Due to the deficiencies in television viewing there is a tendency, and justifiably so, to use closeups, because middle and distance shots appear indistinct.

For the same reason, middle and distance shots in drive-in theater production should also be avoided. There again, a predominance of close-up shots is a desirable thing, if drive-in theaters are going to be designed with 10 W viewing. So, you are correct.

Picture Content Compromise

A picture which would be photographed carefully for a drive-in would not be good for regular motion picture theaters, but there is always a happy medium. You must be sure that the close-ups are not too close up, and that the distant shots are not too distant. You have to compromise, and I believe that this could be done easily enough so that there would be neither too many close-ups for viewing in the regular theater, nor too few, for the drive-in theater.

WALTER E. DUNN: You have made repeated references to the elimination of black screen masking. Do you have any recommendation for either a substitute or a system of elimination of the mask in an existing theater?

Luminous Screen Masking

MR. SCHLANGER: There are several methods of eliminating black masking. First of all, we have to realize that black maskings were originally created for purposes which no longer exist. One was that screen illumination in the early days was comparatively low and the black masking went a

long way toward making the illumination appear brighter.

I think that television viewing is proving that black masking is no longer necessary.

EFFICIENT • DEPENDABLE

RECTIFIERS

for Every Type Projection Lamp



**2-Tube
4-Tube
6-Tube**

**Single and
Three Phase
Models for**

- Rotating Feed Angular Trim High Intensity
- Copper Coated Coaxial High Intensity
- 1 K.W. High Intensity
- Low Intensity

Smooth Output Current • Long Life
Low Operating Temperature
Flexibility in Control

Write today for literature or free demonstration.

**THE STRONG
ELECTRIC CORP.**

**31 CITY PARK AVENUE
TOLEDO 2, OHIO**

**PROJECTION LAMPS • RECTIFIERS
SPOTLIGHTS • REFLECTORS**

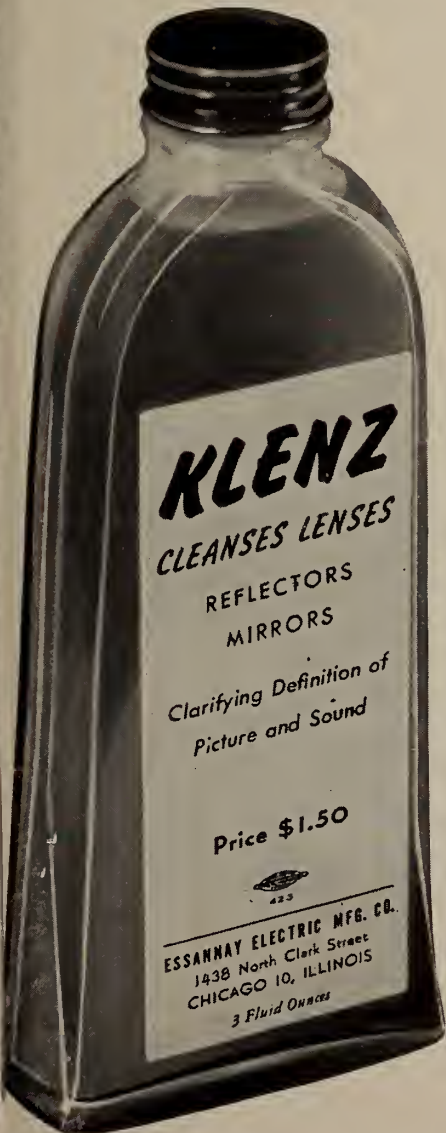

TODAY'S CRITICAL THEATREGOERS

demand sparkling bright pictures... which means that if you have a giant-size screen, you must use Motiograph Hi-Power 75/115 ampere Arc Lamps. They assure brilliant pictures of unwavering intensity—much more light at much less cost—more screen lumens at 100 amperes—with better distribution—than condenser type lamps operating at 180 amperes with heat filters... and carbon costs are less than half. Furthermore they can be operated with less expensive current conversion equipment.



For convincing proof, request a free demonstration in your own theatre. For smaller screens, Motiograph also has 46 ampere lamps and 40 ampere lamps.

For free literature address

MOTIOGRAPH, INC.

“America’s Oldest Manufacturer of Projection Equipment”

4431 WEST LAKE STREET

CHICAGO 24, ILLINOIS

With the exception of the Du Mont sets, practically all the sets have a white or almost-white color masking.

The other reason for black masking was to do something about the aberrated or fuzzy edge of the picture as it is when projected without a black masking. That is a practical problem. This aberrated, fuzzy edge can be eliminated in several ways.

We have been developing a substitute masking, a luminous masking, which I think

will be available very soon. We have also had other solutions in which we would cut the picture, that is, project the picture very carefully into a proscenium which was exactly the size of the picture and let it go at that, or by having a slight flare come right out from the picture. The fuzzy edge would fall on the angular surface, which would not be visible to the audience, and the picture would appear to have a clean-cut edge. Some of the newer maskings that have been developed will do an even better job.

Screen Brightness vs. Size

LEONARD SATZ: There are certain things which can be done right now, short of making major changes. I would say, principally, modernization of lighting would be the first step in the theater auditorium—the elimination of distracting side-wall brackets, which are so common in many of our theaters, and replacement with an operating light which is directed downward and perhaps intentionally directed to the proscenium area.

The first step would be, naturally, the enlargement of the screen, and I believe it is a fact that visual acuity is not lost by the reduction in screen brightness as long as the image is increased in size. You mentioned limitation of screen brightness as being one of the problems of the exhibitor today. I think that if he does lose 10% in incident illumination by enlarging his picture with existing projection equipment, the loss will be compensated by the fact that visual acuity is maintained with the larger picture.

MR. SCHLANGER: It may not be exactly compensated, but certainly acuity increases with the size of the image, despite loss in light. I don't have exact figures on that, but I believe you can verify it.

FILM-GUIDING METHODS

(Continued from page 6)

The use of "studio guides" in theatre projectors is subject to criticism. Guide rails which have been in use for a period of years reveal a small amount of grooving, with one of the two rails grooved more than the other. Because the rails are supposed to be set just far enough apart to clear a new, unshrunk film, the minutest grooving ruins the adjustment, rendering the rails useless unless they are *misaligned* relative to the guide roller so that one rail brings up snugly against the edge of the film.

A groove of only 0.001 inch in each of the two rails permits a side-sway of as much as 0.6 inch in a 24-foot picture. This is noticed by the audience if the swaying is rapid; and it is likely to be more rapid and irregular when studio guides are used than when they are dispensed with entirely.

Most of the films run in the average theatre, moreover, are not new prints. They are narrower than the original raw stock because of shrinkage and the inevitable microscopic shearing that comes of repeated use. Tests have provided conclusive evidence that both the shrinkage and the edge-wear are, within limits, *irregular*. When old prints are projected, therefore, the guide rails are not effective except as they may be misaligned, forcing the film into a fixed position.

To set the rails closer together to edge-guide old prints effectively would



SPECIAL MOTOR GENERATORS FOR EVERY ARC PROJECTION

- Proven "Trouble Free" Performance
- Quality Built, Quiet Operation
- "Rubber in Shear" Mounted Vibration Free
- Long Life, Low Maintenance

Distributed by Independent Theatre Supply Dealers or Write to:

THE IMPERIAL ELECTRIC CO.
AKRON  OHIO
SINCE 1889

Best We Forget—
Wear a BUDDY POPPY

Veterans of Foreign Wars of the United States

This is the **CARBON SAVER** Everyone Is Talking About!

Start now to conserve your supply of carbons which have the heavier copper coating. Now, more than ever, it is important that you make use of every inch of every carbon, and here's the carbon saver that really does the job.

THE CRON-O-MATIC FULLY AUTOMATIC CARBON SAVER

uses up carbon stubs of all lengths with no preparation required. Simply insert in the holder and forget it. It in no way interferes with the regular operation of the lamp. CUTS CARBON COSTS 25%.

Adaptable to Ashcraft "D", Brenkert-Enarc, Peerless Magnarc and Strong Mogul lamps.

Only \$52.50. Quickly pays for itself . . . then goes on to make money for you.

If your theatre equipment dealer cannot supply you, order direct.

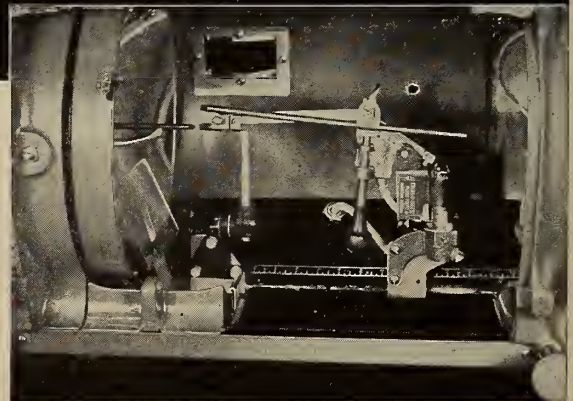

PAYNE PRODUCTS COMPANY

Cron-O-Matic Division

2454 W. Stadium Blvd. Ann Arbor, Michigan
 Please send free literature on Cron-O-Matic Carbon Saver.
 Send name of nearest dealer.
 Please ship Cron-O-Matic Carbon Saver,
 C.O.D. including postage, Remittance herewith.

NAME
 THEATRE
 STREET
 CITY & STATE

Dealer Inquiries Invited

make the passage of splices through the gate more conspicuous on the screen, and also cause new, unshrunk films to buckle and flutter.

Then, too, it is difficult to understand how the flanged guide roller can function freely and properly when studio guides are used. The slightest displacement in the lateral positioning of this roller automatically misaligns the guide rails.

Motiograph, happily, abandoned studio guides altogether in the Motiograph AA, introduced in 1947. The two guide-roller assemblies used in the AA function so well that not a single report of side-sway has come in from nearly 3000 installations. The writer holds that the use of two guide rollers is mandatory in all high-grade projectors.

Provisions for quickly adjusting the pressure of the tension pads of the gate are now incorporated into several projectors. The Brenkert models, for example, and the Simplex E-7 and the new X-L, have conveniently located adjustment screws for this purpose. The Motiograph AA has a positive-acting tension adjustment which can be instantly set in any of three pre-determined positions to obtain the best results with new, old, or only moderately worn prints, thus eliminating all guesswork.

Another noteworthy feature of modern projector gates is the special framing aperture located at the top of the film gate. In the Motiograph AA this threading-up aperture is inclined at a convenient angle so that the projectionist need not be a contortionist in order to thread the film "in frame."

Regardless of the make and model of the projectors used, the projectionist can do much to keep the film gate in perfect condition, thereby insuring good intermittent action and satisfactory functioning of the lens. A few suggestions:

Suggested Projectionist Procedure

1. **CLEANLINESS AND LUBRICATION.** Keep all parts of the gate scrupulously clean at all times. The tension pads of the gate door should be taken out for thorough cleaning—dust from the film lodges underneath them. Remove hardened deposits of emulsion from the film runners with a scraper made from soft copper wire, wiping off the residue with carbon tetrachloride or cleaner's naphtha. (*Caution!* Carbon tet is very poisonous; naphtha is inflammable).

A small drop of projector oil applied to the guide-roller shaft and pivots will insure proper rotation. A toothpick can be used for applying the oil. The slides of the gate door should also have a thin film of oil on their surfaces. Light oil is best avoided—the heat of the gate causes it to vaporize and fog the lens.

The steel film tracks and tension pads may be lubricated every few months by rubbing the metal surfaces which contact

the film with a trace of heavy Vaseline. Excess grease should be wiped off with a clean cotton cloth—enough of the lubricant will sink into the pores of the metal to be effective for a long time.

2. **PAD TENSION.** If the projectionist has had long experience with the make of projector he is using, he can test the tension of the gate-door shoes with his fingers. A more accurate test can be made by determining the drag on the film with a small cylindrical spring scale

Attach a 1-foot strip of film to the

hook of the scale, and pull the film up through the closed gate by means of the scale. The reading indicates the pressure exerted on the film by the pads.

Proper Pad Pressure

From 12 to 16 ounces of pressure is recommended for the average well-seasoned print. Too little pressure may result in an unsteady picture; too much will wear out the film and notch the teeth of the intermittent sprocket. The pads on each side should exert equal pressure—from 6 to 8 ounces—else side-sway may be introduced into an other-

ANSWER TO YOUR TECHNICAL PROBLEMS...



*The
Altec
Service
Man*



161 Sixth Avenue,
New York 13, N. Y.

PROTECTING THE THEATRE—FIRST PLACE IN ENTERTAINMENT

CLAYTON BALL-BEARING EVEN TENSION TAKE-UPS

For all projectors and sound equipments

All take-ups wind film on 2, 4 and 5 inch hub reels.

Silent Chain Drives

THE CLAYTON REWINDER

For perfect rewinding on 2000-foot reels.

CLAYTON PRODUCTS CO.
31-45 Tibbett Avenue New York 63, N. Y.

wise perfect picture. A foot-long strip of film cut lengthwise through the middle is used for testing each side separately.

When there are upper and lower sets of pads (as in all machines except the Powers), the pads at the aperture should exert almost twice as much pressure as the upper set of pads. This makes for a steadier picture, reducing side-sway and film-flutter to a minimum.

Check each pad frequently for surface wear. Replace worn pads immediately, for they can ruin the stationary film-runners, hollowing them here and there, and cause in-and-out-of-focus flutter of the film.

3. **INTERMITTENT SHOE.** In some projectors the intermittent shoe is part of the gate door; in others it is a separate component. In either case it should be examined for lateral adjustment. Although several projectors have adjustable shoe tension, the writer does not believe that the amount of pressure exerted by the shoe against the face of the sprocket is of much importance. It is only necessary that the film be held snugly against the intermittent sprocket; the lightest pressure suffices to do this.

If the shoe rubs against the sides of the sprocket teeth it will damage them, and also deface the film perforations. Center the shoe so that no loud intermittent noise is heard when the machine is run without film, and with the intermittent shoe closed against the sprocket.

Tests of Film Runners

4. **FILM RUNNERS.** The two steel strips upon which the film rests during its passage through the gate will in time show signs of wear. Ordinary steel runners wear out rather quickly; alloy-steel runners of the nickel-molybdenum type are good for years; while runners specially ground from tool steels of the uranium-cerium type have an enormously long life.

The friction of moving film causes the runners to become grooved, a defect which may be detected by scraping a sharp-edged copper coin across each runner laterally. A "click" indicates grooving. Grooving may also be detected by feeling the runner surfaces with the fingers—the sense of touch in the fingertips is extremely delicate.

Wear of the runners is greatest, of course, where the tension pads press the film against them. Such wear is evidenced by a hollowing, best detected by placing a short steel straight-edge against the runner and shining a flashlight on the casting behind it. The straight-edge used for this purpose should be of the best quality, and kept in a velvet-lined box.

A hollow of the runners in the vicinity of the aperture can throw one edge or,

more frequently, one corner of the projected picture out of focus. The writer has encountered and corrected this defect several times. All that is needed is a new pair of runners.

Grooved and hollowed-out runners should be replaced *immediately* with new ones. Some "off-make" parts are very good, but the projectionist must rely on his own judgment when ordering them. In the days to come we will be very lucky to get any parts we need!

When only one runner appears to be worn, it is a good idea to replace both of them, and re-check the evenness of pad tension. In certain projectors the runners and aperture-plate assembly are combined in a single block of ground and hardened steel. The entire unit can be removed and replaced in a moment.

Guide Rails, Rollers

5. **GUIDE RAILS.** The rails of studio guides are subject to grooving by the edges of the film, and hence must be reset and replaced at intervals. The clearance must be such that a new, unshrunk film can just squeeze in between them without binding or buckling.

6. **GUIDE ROLLERS.** Failure of the guide rollers to turn invariably results in scored flanges. These, as well as bent flanges, cause side-sway; replace immediately. If the assembly is properly lubricated, failure of the guide-roller shaft to rotate calls for examination of the pivot bearings. They should not hold the roller so tightly that the film cannot impart a rotary motion to the flanges. On the other hand, there should be no end-

play in the roller shaft. Anything wrong with the guide roller, or with the way it is held in the gate, is certain to spoil the quality of the picture.

Lateral adjustment of the guide-roller assembly is usually made with the set-screw in the collar of the "fixed" flange—not with the pivots. It sometimes happens, however, that the position of the pivots needs correction. Care must be taken, when working on them, not to let them drop into the mechanism or onto the floor and get lost! As all projectionists know, the lateral positioning of the guide roller is very critical, and is correct only when the picture is perfectly centered on the screen. Instructions of the projector manufacturer should be followed when making this adjustment.

The guide-roller spring should press only very lightly against the movable flange. Too great a tension will cause a tendency of the film to "pinch out" or buckle in the gate. The remedy is to take the spring from the assembly and cut away a few turns of the coil. And, just as a precaution, have a few extra-guide-roller springs in the spare-parts cabinet.

Extreme care must be exercised whenever the gate door is removed from the "gate-door holder" of the old-style projectors. The screw-holes of the holder are large enough to permit considerable variation in the position of the gate door and its associated intermittent-shoe apron. Unless the correct position is secured, by intention or a lucky accident, the shoe will rub against the intermittent sprocket teeth.

How Many?

Was this copy dog-eared when it came to you? How many men read it ahead of you?

You would receive a clean, fresh copy if you had a personal subscription—and you wouldn't have to wait—you would be first to read it.

Use coupon below.

INTERNATIONAL PROJECTIONIST.

19 West 44 St., New York 18, N. Y.

Enter my subscription for 1 year—12 issues—\$2.50

2 years—24 issues—\$4.00

Foreign and Canada: Add 50c per year.

Name

Address

City State

"The bonds William and I bought for our country's defense helped build a house for us!"

HOW U. S. SAVINGS BONDS PAID OFF FOR MRS. ROSE NY SSE OF BRISTOL, PA.

"There's nothing more wonderful than a house and garden of your own," says Mrs. Nysse.

"And there's no surer way to own one than to save for it through U. S. Savings Bonds and the Payroll Savings Plan!"



Mrs. Rose Nysse says, "In 1942 William and I started making U.S. Savings Bonds a part of our plan for financial security. I joined the Payroll Savings Plan at the Sweetheart Soap Co. where I'm a supervisor, and began buying a \$100 bond each month. I knew that my money was safe and working for me all the time. Buying U. S. Savings Bonds is one of the surest, safest savings methods!"



"Savings Bonds alone made a \$5,000 down payment on our house!" says Mrs. Nysse. "Altogether, we've saved \$8,000 just in bonds bought through Payroll Savings, and we're keeping right on with the plan. And when we retire, our bonds will make the difference between comfort and just getting by. Bond buying is a patriotic and practical way of building a cash reserve!"

You can do what the Nyssees are doing
—the time to start is now!

Maybe you can't save quite as much as William and Rose Nysse, maybe you can save more. But the important thing is to *start now!* It only takes three simple steps.

1. Make the big decision—to put saving *first*—before you even draw your pay.
2. Decide to save a regular amount *systematically*, week after week, or month after month. Even small sums, saved on a systematic basis, become a large sum in an amazingly short time!
3. Start saving automatically by signing up *today* in the Payroll Savings Plan where you work or the Bond-A-Month Plan where you bank. You may save as little as \$1.25 a week or as much as \$375 a month. If you can set aside just \$7.50 weekly, in 10 years you'll have bonds and interest worth \$4,329.02 cash!

You'll be providing security not only for yourself and your family, but for the blessed free way of life that's so important to us all. And in far less time than you think, the financial independence the Nyssees enjoy will be yours to enjoy as well!

FOR YOUR SECURITY, AND YOUR COUNTRY'S TOO, SAVE NOW—
THROUGH REGULAR PURCHASE OF U. S. SAVINGS BONDS!



Your government does not pay for this advertisement. It is donated by this publication in cooperation with the Advertising Council and the Magazine Publishers of America as a public service.

Wise Buy!

FOR THE
DRIVE-IN
THEATRE

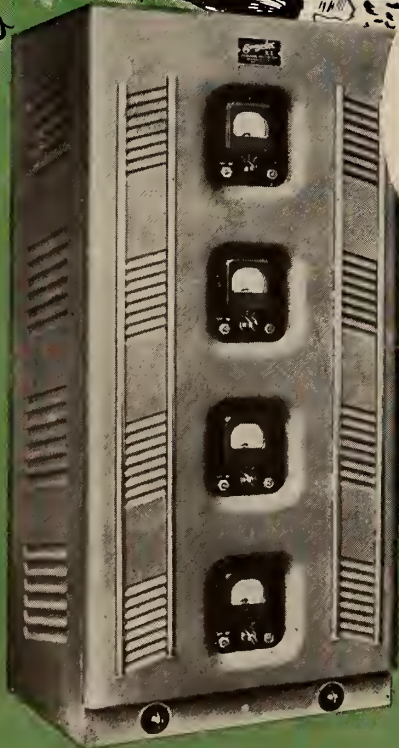

De Luxe
IN-A-CAR
SPEAKER



Standard
IN-A-CAR
SPEAKER

Simplex

TRADE MARK REG'D

**PROJECTION and
SOUND SYSTEMS**

PATRONIZE YOUR LOCAL MOVIE THEATRE FOR THE BEST IN ENTERTAINMENT

MANUFACTURED BY INTERNATIONAL PROJECTOR CORPORATION • DISTRIBUTED BY NATIONAL THEATRE SUPPLY

1933

PROJECTIONIST

INTERNATIONAL



THE LIBRARY OF
CONGRESS
SERIAL RECORD

MAY - 1 1951

COPY 2

APRIL

1951

VOLUME 26

• NUMBER 4

30c A COPY

• \$2.50 A YEAR

7 out of 10
choose

Peerless
MAGNARC
TRADE MARK REG

1-KW TO 70 AMPS

"HY-AX" ARC MAGNET

"HY-LUMEN" REFLECTOR

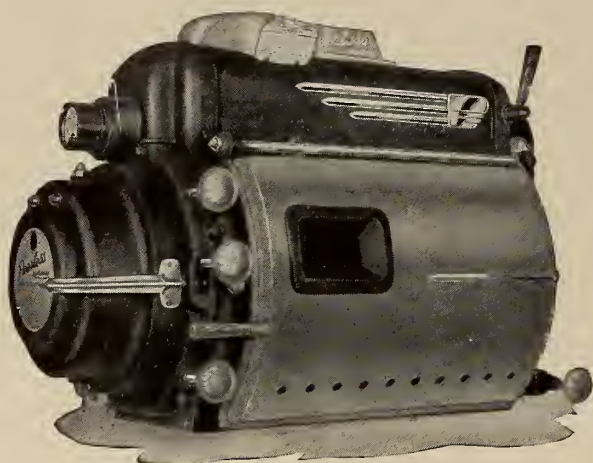

More light at 40 to 70 amperes than ever thought possible. . . . Equals and excels any reflector lamp to 85 amperes, whether they be unapproved water-cooled or resurrected "Hi-Lows". . . . Highest ratio of honest screen lumens per arc watt At 70 amperes, using an accurated Glass Hy-Lumen Reflector*, with a projector having an efficient revolving shutter, it develops the maximum screen brilliance that can be used without a heat filter at no risk of film damage. . . . Operating costs under these conditions are far below that of 85-ampere lamps.

Magnarc Lamps assure 80% side-to-center (SMPE Standard) screen light distribution, not a deceptive 60% or "Hot Center." . . . They are all Und. Lab., Inc. listed. . . . They are not insurance hazards. . . . They are and have been for years "The First Choice" of large and small theatres, drive-ins, and the motion picture industry.

*Similar results are not guaranteed if all-metal reflectors are used.

"FIRST WITH THE FINEST"

120-180 AMPERES

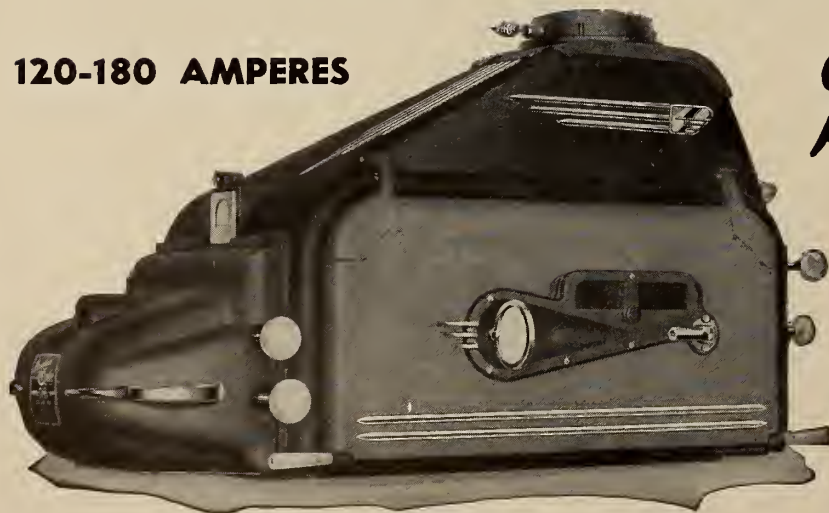

Peerless
HY-CANDESCENT
TRADE MARK REG

NEW MAGNETIC STABILIZER

This modern lamp produces all the light there is. . . . It is the standard equipment of the nation's largest and finest theatres. . . . Used by 90% of the largest Drive-In Theatres.

It is the "Omega" for maximum screen brilliance. . . . Nothing can even approach it in white light volume when used with projectors that have efficient revolving shutters.

Assures satisfying projection for Drive-Ins regardless of the size of the picture, length of throw, and under all weather conditions. . . . They are Und. Lab., Inc listed and, therefore, not insurance hazards. . . . Heat filter assures no risk of film-heat damage at maximum arc amperage and maximum screen lumens.

"WHY EXPERIMENT?"



J.E. McAULEY MFG. CO.

552-554 WEST ADAMS STREET
CHICAGO 6, ILLINOIS

INTERNATIONAL PROJECTIONIST

With Which Is Combined PROJECTION ENGINEERING



HENRY B. SELLWOOD, *Editor*

Volume 26

APRIL 1951

Number 4

Index and Monthly Chat	3	Theater Television <i>via</i> the RCA PT-100 Equipment, V	18
Honeycomb-Condenser Lamp Optics	5	In the Spotlight	20
A. R. SCHULTZE		HARRY SHERMAN	
Evaluation of the Honeycomb- Condenser Lamp	6	Ray Brian's Projection Lore	22
ROBERT A. MITCHELL		Personnel Notes	22
Projectionist Examination Ques- tions	9	IA Elections	22
Tv Won't Ruin Everything	10	IA-IP Radio Contest Results	23
RUPERT HUGHES		Current IA-IP Amateur Radio Listing	24
Comparative Data Anent Ni- trate, Safety Film	13	Simplex Honors 50-Year Em- ployee	25
KODAK RESEARCH LABORATORIES		GPL Theater Tv Premiere in Pittsburgh	26
New Plastic Correcting Lens	16	Book Review	27
Interference Mirrors for Projec- tion	17	News Projections	29
SMPTE Jottings	17	Technical Hints	
		Miscellaneous Items	

Published Monthly by

INTERNATIONAL PROJECTIONIST PUBLISHING CO., INC.

19 West 44 Street, New York 18, N. Y.

Telephone: MUrray Hill 2-2948

R. A. ENTRACHT, Publisher

SUBSCRIPTION REPRESENTATIVES

AUSTRALIA: McGills, 183 Elizabeth St., Melbourne

NEW ZEALAND: Te Aro Book Depot, Ltd., 64 Courtenay Place, Wellington

ENGLAND and DOMINIONS: Wm. Dawson & Sons, Ltd., Macklin St., London, W. C. 2

YEARLY SUBSCRIPTION: United States and possessions, \$2.50 (two years, \$4); Canada and foreign countries, \$3; single copies, 30 cents. Changes of address should be submitted two weeks in advance of publication date to insure receipt of current issue. Entered as second class matter February 8, 1932, at the Post Office at New York, N. Y., under the act of March 3, 1879. Entire contents copyrighted 1951 by International Projectionist Publishing Co., Inc. INTERNATIONAL PROJECTIONIST is not responsible for personal opinions appearing in signed articles in its columns.



MONTHLY CHAT

PROJECTIONISTS may expect that the physical quality of theater release prints will slowly but steadily deteriorate before the opportunity for betterment presents itself. Despite official statement from the NPA in Washington that there is no serious shortage of raw stock "at the moment," leading laboratories report that the situation has come to the point where it suffers from various degrees of acuteness, with comment ranging from "tight" to "very acute." Some labs have decided against taking any additional orders at this time.

This is the situation right now, even though the needs of the military and other government agencies have by no means reached their peak. And the Tv nets' demands for stock will mount steadily.

All this means that there will be fewer prints available on any given release, with faster rotation of prints and consequent less time for inspection in the exchanges. Print quality is none too good right now, and exchange inspection has never been more than meager.

Print quality seems destined to provide plenty of trouble in the months to come, with projectionists having to take over more of the normal functions of the exchange. Close inspection of every print is requisite, and particular care should be taken to establish the nature of the stock—whether nitrate or safety. Eastman's new print identification system should help greatly in this direction (IP for March, 1951, p. 12). Proper splicing will play a very important role in licking this problem.

We're stuck with this problem, so let's face it squarely.

• • •

IP HAS LONG been inured to the circumstance wherein a long succession of its issues containing much material of merit will not elicit a congratulatory word from its readers, the while a minor error in, probably, an equation or the like will induce a raft of comments. 'Twas ever thus.

Of late a new note has been sounded: certain quarters opine that IP should shy away from "all this new stuff" and concentrate exclusively on the "now," since this peering into the future will "serve merely to create dissatisfaction with equipment now being offered."

IP just can't buy this line of thought. Current practice and improved technique in handling existing equipment will ever be a prime concern of IP, of course; but one of the chief reasons for the existence of IP is that it ferret out and publish information on the new and the novel. Any craft journal—and IP is just that, *not* a trade paper or a business paper—that fails in this vitally important function forfeits its right to exist.

IP is important only to the extent of the service it renders its readers.

FOR STUDIOS EVERYWHERE

Western Electric Recording Equipment

If you need	35 mm and 16 mm		35 mm and 16 mm	
	VARIABLE AREA DIRECT-POSITIVE PHOTOGRAPHIC	VARIABLE DENSITY NEGATIVE-POSITIVE MAGNETIC	100 MIL STANDARD 100 MIL PUSH-PULL 200 MIL PUSH-PULL	MAGNETIC PHOTOGRAPHIC
	RECORDING EQUIPMENT		RE-RECORDING EQUIPMENT	

Western Electric has developed it and Westrex can supply it!

RECORDING EQUIPMENT

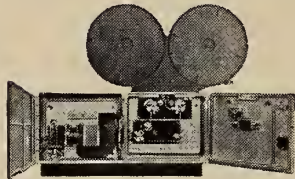

Westrex offers Western Electric photographic recording equipment, available for either area or density recording for outstanding results by either method. The complete line includes systems ranging from a single-film newsreel to deluxe equipment for large studios.

RE-RECORDING AND SCORING CONSOLES



Six models of the Western Electric and Westrex re-recording and scoring consoles are available. These consoles have been designed to fill the needs and meet the budgets of studios throughout the world.

RE-RECORDERS



This line provides facilities for 35mm and 16mm, 100 mil standard, 100 and 200 mil push-pull photographic, and also for magnetic film recordings.

... FOR THEATRES OUTSIDE U.S.A. AND CANADA

Westrex Theatre Sound Systems

SOUND AND PROJECTION SYSTEMS



The Westrex Master, Advanced, and Standard Sound Systems are designed to serve every theatre, large or small, and feature the Western Electric Hydro Flutter Suppressor.

AMPLIFYING EQUIPMENT



Available in power ranges from 15 to 100 watts, all give life-like reproduction even when operated at their full rated capacity.

LOUDSPEAKERS



World famous Western Electric loudspeakers, used singly or in multiple systems for theatres of every size and shape, give quality performance.

ACCESSORIES

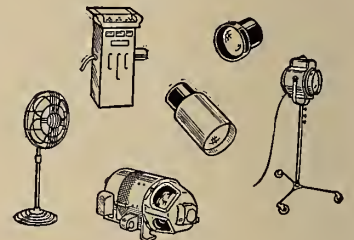

Westrex is a convenient source for all theatre requirements including accessories and supplies of all types, from revolving stages to carbons, from curtains to lenses.

For an evening out... go to the movies!

Research, Distribution and Service for the Motion Picture Industry.



Westrex Corporation

111 EIGHTH AVENUE, NEW YORK 11, N. Y.
HOLLYWOOD DIVISION: 6601 ROMAINE STREET, HOLLYWOOD 38, CAL.





Honeycomb-Condenser Lamp Optics

The appended article, in two sections, comprises a translation from the German by Robert A. Mitchell of an article "Die Wabenkondensor" in *Bild Und Ton* (Bd. 3, Nr. 4, S. 127) and supplementary comment by the translator. This material is published herein in line with the long-established policy of IP in providing a forum for the free and full expression of views by anybody having anything interesting to say about the projection process. Comment on the appended article is invited.

By A. R. SCHULTZE

Zeiss-Ikon, VEB, Dresden

CRITICAL examination of picture reproduction in motion picture theaters unfortunately often forces one to the conclusion that the quality of the projection leaves something to be desired. Even though the necessary picture brightness can be attained in all cases by means of modern mirror lamps, insufficient uniformity of illumination and of the color of the picture are ever-present defects, the latter being especially troublesome during the presentation of color films.

The cause is to be sought in several factors which lie as much in the lamp optics as in the quality of the carbons used and in the attention given to the operation of the lamp.

The claim is here advanced that the disadvantages of conventional lamps may be considered obviated by the *honeycomb*

FIG. 1. Representation of an arclamp optical system using a concave mirror.



condenser optical system. With this system the slight falling-off of illumination at the edges of the picture, the sensitivity of the lamp optics to trim-position and burning errors, as well as color variations in the picture with the use of Beck [high-intensity] carbons, are overcome.

In the conventional mirror lamp the luminous crater of the positive carbon is imaged on the picture-aperture by the mirror, the path of the rays being shown in Fig. 1.

Irregularity of Illumination

Every irregularity in the crater and every alteration in the position of the crater image [the "spot"] cannot help but result in an irregularity in the illumination of the picture, especially when high-intensity carbons are used. Slantwise burning of the carbon shows up on the screen as colored corners and edges, the reason being that the crater, when viewed across the white gas-ball, has a yellowish to reddish color.

And especially when low-current intensities are employed, the correct imaging of the crater and its position relative to the mirror must be maintained very precisely, and to a degree of accuracy not feasible in practice. Hence screen illumination free from defects is no longer attempted with currents under 40 amps

because of the small area of the positive crater.

These disadvantages are avoided with the familiar condenser-utilizing lamp optical-system, the so-called *Kohler arrangement*, because with this system it is not the picture-aperture but an interposed auxiliary condenser upon which the crater of the positive carbon is imaged. And the condenser, in turn, images the "principal condenser" [a large condensing lens analogous in function to a lamp mirror] upon the aperture.

With this system, also called the "intermediate image-formation arrangement," no influence upon the illumination is exerted by incorrect position or oblique burning of the positive carbon, as the image of the principal condenser, not that of the crater, lies on the picture-aperture. In consequence of the low efficiency of a condenser system, the application of this type of arc-imaging for projection in motion picture theaters has not succeeded until the present time.

New Condenser a Requisite

It might be supposed that we could at once set about applying this system to a mirror lamp, as shown in Fig. 2. But this is not possible because a dark shadow, originating from the carbon-holder and carbon which naturally lie between the

FIG. 2. Optical system utilizing concave mirror and intermediate-image formation.



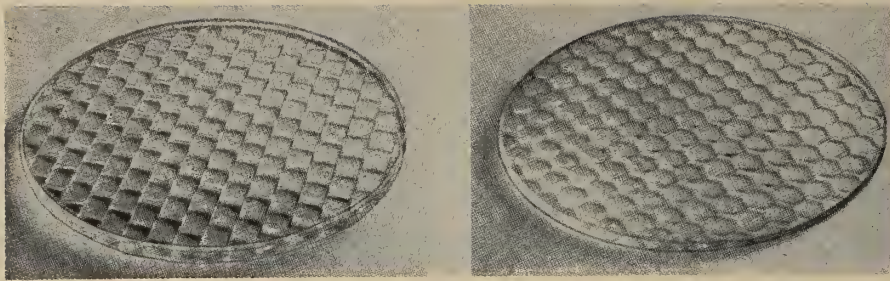

FIG. 3. Lens plates holding an array of 150 individual lenses: rectangular and hexagonal plates.

mirror and the intermediate condenser, is visible on the picture-aperture. The intermediate image-formation setup just represented can be realized, however, if the so-called honeycomb condenser is used. This consists of two lens-“holding” plates, as shown in Fig. 3.

These will be interposed at a definite place in the light-beam of the mirror lamp, as shown in Fig. 4. Each lens plate has the same number of lenses. Now, the arrangement of the separate lenses is so contrived that each lens of one plate is coordinated with a lens of the second plate. That is, the focal lengths of the lenses of the first plate are chosen so that each lens always forms an image of the crater in the corresponding lens of the second plate.

The lenses of this plate, in turn, will image every corresponding lens of the first plate on the aperture of the projector. All images of the individual lenses of the first lens-array accordingly superimpose themselves on the aperture. Thus with this intermediate image-formation system the whole of the light-beams coming from the mirror is subdivided into a large number—about 150—single light-beams.

In conformity to their practical application, the lenses of the first plate are rectangular, their images corresponding in size and shape to the picture aperture; lenses of the second plate are hexagonal, approaching the circular form of the arc crater.

The manifold subdivisions of the light-beam by the honeycomb-condenser system has the great advantage of retaining the desirable characteristics of the intermediate image-formation system.

High Operating Efficiency Assured

Due to the fact that the desirable properties of the intermediate image-formation system are retained, the manifold subdivision of the light-beam by the honeycomb-condenser system has the great advantage that one can utilize fully the high operating efficiency of a concave mirror without a shadow of the carbon-holder or the carbon showing up. The single lenses of the first array are indeed partially covered by this shadow; but this non-uniformity is obliterated at the aperture by virtue of the fact that the

images formed by 150 individual lenses are superimposed.

In line with the characteristics of the intermediate image-formation system, there is also considerable independence from the exact imaging of the crater. Sidewise burning of the crater, for instance, is not perceptibly detrimental to

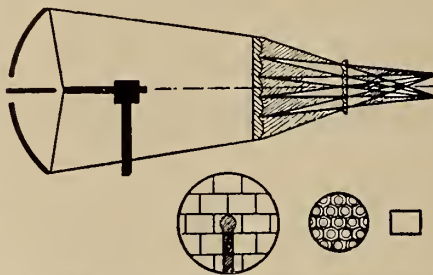

FIG. 4. Optical system which utilizes the “honeycomb” condenser.

the uniformity of the illumination of the picture aperture. Moreover, it is also possible to attain uniform picture illumination with lower currents, *i.e.*, a smaller crater.

This mirror combination, therefore, has the following advantages:

1. Continuously uniform and color-free picture illumination, even with faulty carbon positioning and imperfect imaging of the crater, rendering unnecessary the otherwise customary attention to the arc and mirror knobs for truing up picture quality during projection.

2. Use of Beck (h-i) light even with currents from the present minimum down to 15 amps, so that h-i light, the superiority of which is well known—in particular for the projection of color films—can be employed even in the smallest theater.

Not only does the honeycomb-condenser system bring about important operational advantages, but very likely a substantial simplification of the construction of mirror arc-lamps, too.

No Guides, Position-Controls

Guides and position-controls for the carbons and for the mirror are no longer necessary, since their precise position no longer has any great significance. It suffices if the carbons are fed at their ends by the carbon supports. Focusing knobs for the mirror can also be dispensed with. If such a lamp is once lined up correctly at the factory, no operating adjustments for maintaining picture quality are necessary during the time that the lamp is in use.

The Ikosol honeycomb-condenser lamp manufactured by Zeiss Ikon VEB, Dresden, is shown in Fig. 5. This lamp is equipped with such customary accessories as an automatic carbon feed, combination arc-striking and light-beam doublers, as well as a latch-release device for the carbon holders. For use the lamp comes with an aspheric mirror of 300 mm. [11.811 inches] diameter.

Evaluating the Honeycomb-Condenser Lamp

By ROBERT A. MITCHELL

THE introduction of the Zeiss Ikosol honeycomb-condenser lamp goes far toward meeting two very important needs, from the point of view of Soviet-

German motion picture technologists. The first is the need for satisfactory screen illumination—which need is universal and was recognized by INTERNATIONAL PROJECTIONIST years ago. The second is the need, they feel, for decisive

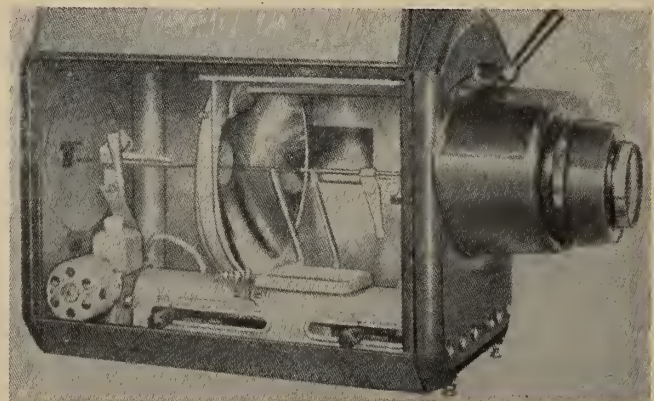

Fig. 5. The Zeiss Ikosol honeycomb-condenser lamp. Note lightness and simplicity of this lamp.

The Most Reliable of Drive-In Speakers



**THE RCA In-Car SPEAKER
IS FIRST IN ITS FIELD**

... in better quality... in longer
life with lowest maintenance
costs... in popularity (More
RCA In-Car Speakers are used
in Drive-Ins than any other make.)

**ORDER RCA In-Car SPEAKERS NOW
TO REPLACE OBSOLETE or OLD In-Car SPEAKERS**

SEE YOUR NEAREST INDEPENDENT RCA THEATRE SUPPLY DEALER FOR COMPLETE INFORMATION



**THEATRE EQUIPMENT
RADIO CORPORATION of AMERICA
ENGINEERING PRODUCTS DEPARTMENT, CAMDEN, N.J.**

In Canada: RCA VICTOR Company Limited, Montreal

IT'S REALLY

UP THERE

when it comes to projecting
BIG, BRIGHT pictures!

NATIONAL EXCELITE PROJECTION ARC LAMP

For super-brilliant pictures on large screens **AT LOWER OPERATING COST**, buy this 75 to 130 ampere high intensity reflector type lamp.

- ★ Air-cooled rotating positive carbon feeding mechanism.
- ★ Big 16½" reflector matches high speed f/1.9 lens.
- ★ Automatic arc crater positioning.
- ★ Stable burning and complete combustion at the arc, to avoid any black soot, are attained by a jet of air directed just above the arc.
- ★ White smoke, which would otherwise cloud the mirror, is also diverted by this air stream.
- ★ Unit construction permits instant removal of components for cleaning.

Distributed by

NATIONAL
THEATRE SUPPLY

Division of National • Simplex • Bludworth, Inc.

"THERE'S A BRANCH NEAR YOU"

Soviet superiority in *all* technological fields.

Indications that this second need is being met with increasing success on the other side of the Iron Curtain may well be viewed with alarm by the Western world. The implications are both economic and military.

Among other recent East-German successes in motion picture technology we find simplified stereophonic sound systems, experimental stereoscopic movies, improved soundhead optics, wide-latitude color processes, specially perforated film-gate runners which "cushion" the film and prevent deposits of wax and emulsion, and cameras and projectors of new design.

The well-known Agfa Film Corp., now resuscitated and completely Sovietized (as is everything else in East Germany), gushes forth an output of raw stock which is nothing short of prodigious. A new projector by Ernemann (the Model 10) is soon to have its debut—an incidental reflection of technical know-how of the highest order—and an increase of East-German steel production from 500,000 to 6,000,000 tons per annum in the past four years.

American Manufacturers' Concern

These developments should gravely concern British and American manufacturers of theatre equipment because the Eurasian equipment may be superior to Western makes in quality and performance. It will certainly be lower in cost, especially to exhibitors in dollar-short countries. America has already lost its supremacy in the production field. Is history to repeat itself in the technological field? The answer to this question will not be long in coming.

The time to make much-needed advances in American and British projection technology is NOW! Five years from now, three, or even *one year* from now may be too late.

Whether or not "movies are better than ever" is a matter open to dispute; but it's a safe bet that movies are no better than the quality of the projection that puts them on the screen. The best productions—films that the theatre-going public *wants* to see, and to see *at their best*—are being sabotaged daily in thousands of theatres by antiquated and run-down projection and sound equipment.

Faulty Projection Widespread

Faulty screen illumination, picture flicker, fuzzy images, and sound suggestive of Edison's talking machine reign malignantly in countless neighborhood theatres, the mainstay of the film industry. Rotten projection, like rotten pictures, means rotten business at the box-office!

Now, the real rub is that these per-

sistent gremlins cannot always be banished by the simple expedient of replacing old equipment with new. The new may be nothing but a rehash of the old, a factory-fresh materialization of pre-war—yes, even pre-sound—concepts of design. There are excellent projectors, lamps, and sound systems, to be sure; and for every theatre there is a "best" make and model of projection equipment. But could not, *should not*, the "best" be superseded by a "better"? Is the best really good enough to meet to-days exacting patron requirements, to meet standards of projection higher than those commonly considered official, to meet competition in the entertainment field, to meet the stiff competition offered by equipment of Eurasian manufacture?

This competition will soon be in evidence on the foreign market. And just as foreign films are enjoying an increasingly warm reception by intelligent American audiences, the possibility that foreign-made theatre equipment will infiltrate into the Americas on its *own merits* actually exists! Canada and South America are already fertile fields for such an invasion.

American Conservatism Noted

The writer has expressed the opinion several times in the past that many manufacturers of theatre equipment have shown themselves strangely, even unreasonably, reluctant to institute *substantial* improvements in projector design. Such improvements have been made, of course, and in the United States by every projector manufacturer.

On the whole, however, a conservatism prevails which makes the real advances appear minuscule when viewed against the protracted periods of time required for their development and commercial introduction.

For example: how many projector manufacturers have seriously considered replacing the orthodox 3-to-1 intermittent movement with a 5-to-1 movement in order to take advantage of the flicker-reducing 3-blade shutter? Have exhaustive tests been conducted with the buckle-eliminating curved picture gate?

Then, too, the use of bulky and heavy sound "heads" separate from the picture mechanism can be criticized on very logical grounds. Motion pictures are no longer run "straight silent." Why, then, are picture mechanisms constructed as "silent" machines without integral sound-reproducing components? Such attachments add very little to the total bulk of a projector mechanism, as the German Ernemann VII-B, the Dutch Philips, and the American DeVry clearly demonstrate. A very desirable simplification results.

Screen Light Distribution

As important as any possible improvement of the projection process is the attainment of screen illumination which is uniform (from 90 to 95% side-to-center distribution) and is reasonably free from discolorations. This problem has been recognized as mighty important by projection engineers in Germany, but *not* in the United States and Great Britain. The work and opinions of Zeiss engineers simply cannot be laughed off or brushed aside as of no consequence.

Three distinct methods of obtaining uniform screen illumination have now been presented in IP. First, the Ventarc optical system specially designed for a
(Continued on page 34)

¹"The Ventarc H. I. Carbon 'Blown' Arc: a New Concept" by Dr. Edgar Gretener; IP for July 1950, p. 13. "Uniform Screen Light Distribution; Elliptical Reflector Mirrors" by Sam Glauber, Dr. E. Gretener, and R. A. Mitchell; IP for September 1950, p. 13.

²"Optics of the Projection Arc-Lamp"; IP for February 1951, p. 5.

Projectionist Examination Questions

Based on Examinations by Leading U. S. Municipalities

1. A rheostat is rated at 1250 watts and has a resistance of 2 ohms. This rheostat may carry, at rated conditions, how many amperes?

2. An imaginary straight line passing through the exact center of a lens or of all the elements of an optical system is called _____?

3. In a 35-mm projector running at 90 ft. per minute, how many frames of film pass the aperture in one minute?

4. What per cent of the stamped rating is the *actual* rating of a link fuse?

5. A projector carbon having no core is called _____?

6. What is "voltage drop"?

7. Give the allowable carrying capac-

ity of at least five different sizes of wire with which you are familiar.

8. What is the resistance of a wire that has a 3½-volt drop when carrying 45 amperes?

9. How many amperes are flowing in a wire with a resistance of 1/25th ohm if there is a drop of 2 volts in it?

10. Describe the method by which dry and brittle film may be cleaned and moistened.

11. What is the maximum current-carrying capacity for a 7-mm Suprex positive carbon? For an 8-mm?

12. What may cause the repeated pencilling of the negative carbon?

BILL NYE, now forgotten, but once a household word for popular humor, told of going into a cheap restaurant for breakfast. A cross-eyed waitress first cleared away the debris left by the previous customer, and brushed the crumbs into Bill's lap. Then she turned on him and snapped: "Tea or eggs?" That is all there is to the story.

Nobody seems to think it odd that everybody is always saying tea-or-egg things, like: "Shall we have the theater or the moving picture?" "Shall we have classical music or popular?" "Shall we have motion pictures or radio?" "Shall we have radio or television?"

When Bill Nye heard the cross-eyed waitress exclaim "tea or eggs" his instinct was to say, "Tea and eggs, also a lot of other things." But when we are asked, "Shall we have motion pictures or television?" it is not taken as a bad joke but as an inevitable and perilous choice. Television is being hated and denounced, and the cold war over it is getting as hot as the long struggle with Russian communism. Television is being viewed as the fatal enemy of everything dear and artistic, profitable and moral.

The 'Pernicious' Bicycle

I am old enough to remember when the craze for bicycles "killed" the theaters, the church, the concert hall and reading habits at home. It also ruined the morals of boys and girls, since it enabled them to get far away from home.

After the bicycle had served its time as the explanation for the failures of such books, plays, concerts and other merchandise as failed to do well, the automobile came along. It was blamed for ruining the publishing business, the theatrical and concert business, and the morals of boys and girls, since it enabled them to get even farther away from home than the bicycle. The motorcar was considered to be a sort of bedroom and barroom on wheels, and it could park wherever it was dark.

After the automobile had established itself as an institution that could not be sermonized or editorialized away, the motion picture house came along to take the blame for everything deplorable. The nickelodeon and the vast palaces it developed into, were plainly the reasons why nobody stayed at home to read or went to the legitimate theater, or even attended vaudeville or burlesque. The motion picture was castigated for cutting down church attendance, which has never been satisfactory in any age. Furthermore, dramatic critics reviled the unpardonable cinema almost as violently as the parsons did. Critics who hated most plays spoke of the theater as a temple

Tv

Won't Ruin Everything*

By RUPERT HUGHES

of high art when they contrasted it with the motion picture houses.

The Onslaught of Radio

Next came radio! It went down the line like a bowling ball, sending all nine of the ninepins flying in a strike. People stayed at home, but they did not read books or magazines or newspapers. They listened to serials, soap operas, music, news, science, comedy and plays. They absented themselves from church, wrestling matches, prizefights, baseball and football games, gambling clubs, night schools, saloons, lectures, grand and comic operas, tragedies, comedies, vaudeville, burlesque, family reunions, and everything else. People lost their eyes and legs from disuse and became all ears.

But cheer up, the worst was yet to come! Television!! That not only killed off everything that radio had killed off, but also killed off radio. People stayed at home more than ever, but not to read. They forgot all the arts and the pleasures even of conversation. Television brought back only one thing, the barroom. It made beer and hard drinks popular once more, since people had to put up some

excuse for leaning on the rail half the night staring goggle-eyed at television's one bright eye.

So now today the book publishing business is dead; the theater business is dead in all its branches; the churches and lecture halls are empty; the motion picture houses are dark and silent. The football fields, boxing arenas and racing parks are half empty. And the radio sets are gathering moss.

Some Outstanding Exceptions

Of course, there are exceptions, though nobody mentions these. Some of the churches are packed; some of the legitimate theaters are doing \$50,000 a week; many of the motion picture houses are jammed with eager multitudes; some of the books are having enormous sales; some of the magazines have circulations of millions; some of the newspapers are almost too heavy to lift.

But the denouncers of the plague of television forget that, long before television, radio, motion pictures, automobile or bicycles were even heard of, most churches were sparsely attended; most theaters housed failures; most books died in the store-rooms; most magazines and newspapers perished of pernicious anemia; most poets, painters, playwrights, actors, sculptors, evangelists, singers died of starvation or earned their livings in other fields.

It was not until shortly before Columbus discovered America that books began to be printed from movable type and, doubtless, that innovation was also denounced for destroying the livelihood of strolling minstrels, strolling players, strolling friars, copyists and illuminators.

One other thing has always been true. While the blind poet, Homer, begged for bread for his songs, other rhapsodists became favorites of wealthy patrons and lived in luxury. Actors have always been looked on as more or less beggars in

(Continued on page 32)

FAMED MUSIC HALL (N. Y.) REFURBISHES WITH 4-PROJECTOR INSTALLATION



Installation of 4 Simplex X-L projectors in Radio City Music Hall (New York) is discussed by Chief Projectionist Charles Muller (left) and Arthur Meyer, sales chief for International Projector Corp.

* This engaging dissertation appeared in the 45th anniversary issue of *Variety* and is reproduced here by permission of that journal.



You can't skimp on studio lighting!

THERE'S NO SUBSTITUTE FOR CARBON ARCS
WITH **NATIONAL** CARBONS!
TRADE-MARK

● Studio lighting represents but a tiny fraction of the cost of making a movie. But it makes a tremendous difference in the quality of the final picture. Now is no time to jeopardize picture quality. Now is the time to put on better pictures—pictures with diamond-sharp detail, true color values, with terrific emotional appeal (obtainable only through proper lighting) — pictures that people will pay to see. There is no substitute for *CARBON ARCS* — with "National" carbons!

**ALWAYS BUY
"NATIONAL" CARBONS**

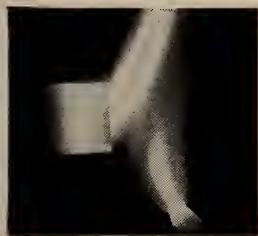

The term "National" is a registered trade-mark of
NATIONAL CARBON COMPANY
Division of Union Carbide and Carbon Corporation
30 East 42nd Street, New York 17, N. Y.

District Sales Offices: Atlanta, Chicago, Dallas, Kansas City,
New York, Pittsburgh, San Francisco
In Canada: National Carbon Limited, Toronto 4



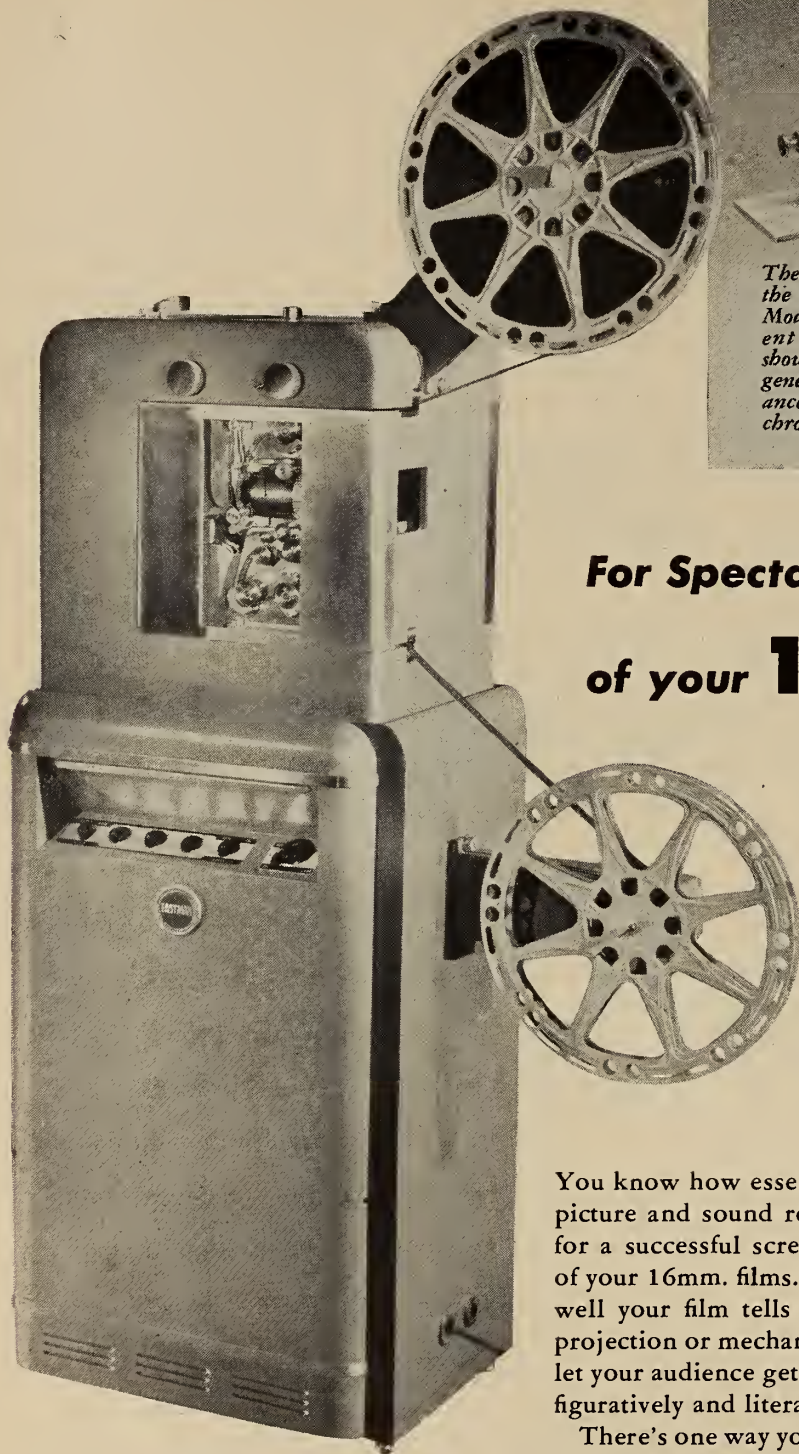

*Eastman 16mm. Projector,
Model 25,
adapted for tungsten
illumination.*

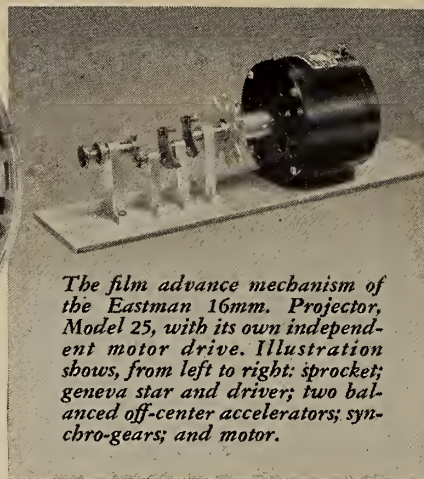

The film advance mechanism of the Eastman 16mm. Projector, Model 25, with its own independent motor drive. Illustration shows, from left to right: sprocket; geneva star and driver; two balanced off-center accelerators; synchro-gears; and motor.

**For Spectacular Screen Presentation
of your 16mm. FILMS . . .**

THE EASTMAN 16mm. PROJECTOR, Model 25

You know how essential top-quality picture and sound reproduction are for a successful screen presentation of your 16mm. films. No matter how well your film tells its story—poor projection or mechanical failure will let your audience get away from you, figuratively and literally.

There's one way you can be certain of top-quality screen presentation—by projecting your films with an Eastman 16mm. Projector, Model 25. Here are a few of the many reasons why.

First, the Eastman Model 25 is the result of an entirely new design concept. It is an applied engineering

solution to the problems of 16mm. sound projection, capable of continuous-duty, dependable performance.

Second, since it gives you a choice of high-intensity arc or tungsten illumination—plus *Lumenized* Kodak Projection Ektar Lenses—you can get the screen image brilliance, contrast range, and full screen definition you want under your operating conditions.

Third, unparalleled sound reproduction quality is made possible by advanced optical and electronic engineering. It gives you dependable continuous-duty theater-quality screen presentation when you want it.

*Write today for further detailed information on specifications,
prices, and delivery. Address your inquiries to . . .*

Motion Picture Film Department
Eastman Kodak Company
Rochester 4, N. Y.

Midwest Division
137 North Wabash Avenue
Chicago 2, Illinois

East Coast Division
342 Madison Avenue
New York 17, N. Y.

West Coast Division
6706 Santa Monica Blvd.
Hollywood 38, California

Comparative Data Anent Nitrate, Safety Film

The appended article complements the data which appeared in IP last month ("New Eastman Identification System for Safety Film," p. 12) and similarly was prepared and is copyright by Eastman Kodak Co. Comment from the field is invited.

THE hazardous properties of nitrate film have been well known and understood in the motion picture industry for a long time. Safe practices in the handling and storing of nitrate film have been worked out over the years by the cooperative efforts of various organizations, the National Bureau of Standards, the National Fire Protection Association, the National Board of Fire Underwriters, the Underwriters' Laboratories, the Motion Picture Association of America, and the film manufacturers.

Today everyone working in the motion picture industry—whether in studios, laboratories, exchanges, theaters, or projection rooms—is made acquainted with the hazard of nitrate film and with the proper precautions required to handle it safely. As a result, film fires are now remarkably few, and the occasional ones which do occur are usually extinguished quickly with a minimum of loss from personnel injury or property damage.

Advantages of Safety Film

Despite the relatively good safety record in the industry in recent years, a less hazardous film has been a long-sought goal. Its universal use would practically eliminate the chance of a dangerous fire, and it would make possible less rigid safety regulations, less expensive construction, and lower fire insurance rates.

The so-called "safety base" or acetate films available prior to 1947 did not have satisfactory physical properties for general theater use. However, now that an improved type of safety support (high acetyl cellulose acetate) suitable for theaters is available in quantity, the use of nitrate motion picture film in the United States is rapidly declining, and existing safety regulations may gradually be moderated.

Concern is felt in many quarters that with the time approaching when most motion picture film will be on safety support, but with substantial quantities of nitrate film still in use or in storage, safety precautions may be relaxed too soon or a mistake in identity may be made and a disastrous fire result.

Hazards of Nitrate Film

The hazardous properties of nitrate film have been described frequently and in detail in the past and are given only briefly here. The most dangerous aspects of nitrate film are its ease of ignition, its very high rate of combustion, and the fact that the gases given off are ex-

remely poisonous and, under some conditions, explosive.

Nitrate film decomposes readily when heated above room temperature even below the ignition range. The decomposition is both exothermic and autocatalytic, and once it starts it goes faster and faster. The quantity of heat produced is such that, if not dissipated, it may rapidly raise the film temperature to the ignition point. Even local heating at one point can raise the temperature of the film to a dangerous level, thus initiating decomposition in the entire mass.

Cellulose nitrate also contains enough oxygen within the molecule so that decomposition or combustion proceeds

rapidly even in a limited air supply, and a nitrate film fire cannot be extinguished by smothering.

Nitrate Ignition Temperature

Nitrate film itself is not explosive and is less flammable than certain other nitrated compounds. The ignition temperature of nitrate film is generally given as about 300 F, but the exact value depends on the time of exposure, the size and purity of the film, and other factors.

Figure 1 shows that in a laboratory ignition test, a sample of fresh nitrate film base which ignited in 80 seconds in air at 325 F, ignited in 10 seconds at 400 F, and in 3 seconds at 500 F. Chemicals left from processing, dirt, and other foreign materials can lower the ignition temperature.

The Chemical Warfare Service investigation following the Cleveland Clinic disaster (a nitrate X-ray film fire) in 1929 showed that temperatures of 100 C (212 F) were unsafe for nitrate film, and that exposed steam pipes, unprotected electric light bulbs, etc., were dangerous in rooms containing nitrate film. Nitrate film improperly cared for has caused fires after several hours storage at temperatures as low as 120 F. Spontaneous ignition is also believed to be responsible for a number of nitrate film fires which have occurred in storage vaults in summer following periods of 100 F weather.

The actual heat of combustion of ni-

FIGURE 1
Self-ignition temperature in air of Eastman nitrate and high acetyl acetate (safety) motion picture positive film support. American Standards Assoc. test method.

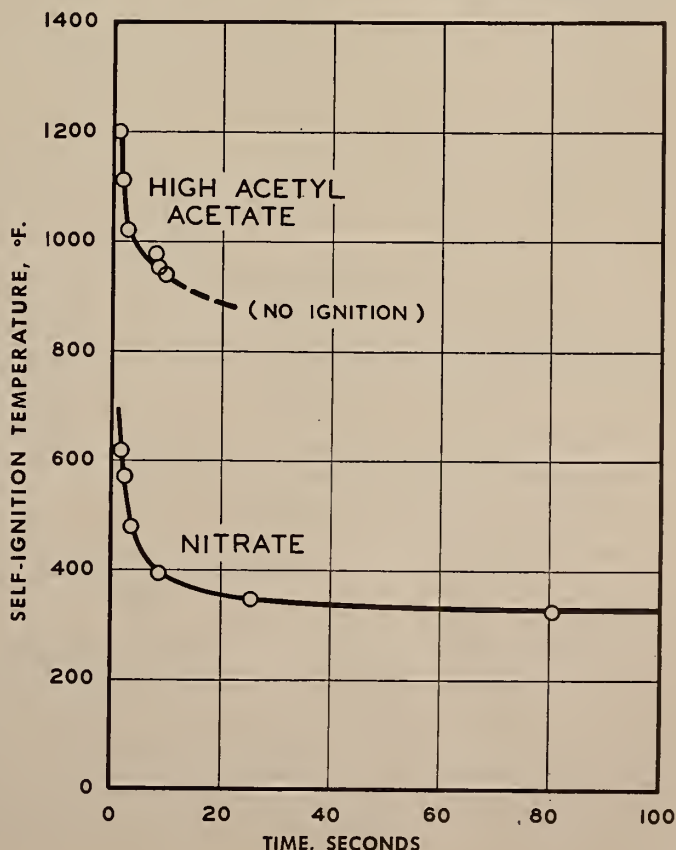

Gases	Per cent by volume
Nitric oxide (NO)	1.4-8.2
Nitrogen dioxide and tetroxide (NO ₂ , N ₂ O ₄)	6.9-8.9
Carbon monoxide (CO)	47.7-59.1
Carbon dioxide (CO ₂)	21.3-24.5
Oxygen (O ₂)	none
Hydrogen (H ₂)	0.9-3.2
Methane (CH ₄)	1.0-2.7

† From "Proceedings of a Board of the Chemical Warfare Service appointed for the purpose of investigating conditions incident to the disaster at the Cleveland Hospital Clinic, Cleveland, Ohio, on May 15, 1929." U. S. Government Printing Office, Washington, 1929.

trate film is low compared with that of some of the common fuels, as indicated:

*Heat of Combustion
B. T. U. per Lb.*

Nitrate Film	6000-8000
Wood	8000-9000
Alcohol, denatured	11,620
Coal, bituminous	10,000-14,000
Gasoline	20,750

However, the rate of combustion of nitrate film is about 15 times that of wood in the same form, so that the heat evolved per minute is initially much greater. This results in a rapid rise in temperature and a very intense fire. A nitrate film fire burns so fiercely and spreads so quickly, it is virtually impossible to control or extinguish it except by automatic water sprinklers.

Gases From Ignited Nitrate Film

When a single layer of nitrate film is ignited and allowed to burn freely in an excess of air, it burns with a bright yellow flame; but the gases given off are colorless. These are chiefly nitrogen, carbon dioxide, and water vapor, none of which is poisonous or explosive. If the air supply is restricted, as is always the case in practice where film is in rolls in any quantity, the film will burn (with or without flame) and give off large quantities of thick, yellow fumes. These are extremely poisonous and may form explosive mixtures with air.

The relative amounts of various gases given off by burning nitrate film in a limited air supply are shown in Table I. Traces of the lethal hydrocyanic acid gas (HCN) have also been found but only in insignificant amounts. Complete combustion yields about 4 to 5 cubic ft. of gas per pound of nitrate film at normal temperature and pressure. The proportions of these gases will vary somewhat with the temperature, pressure, air supply, and so forth.

The toxicity of carbon monoxide is well known; but the physiological effects of the nitrogen oxides (NO, NO₂, N₂O₄) are even more insidious because of their greater toxicity and delayed action. Exposure to concentrations of nitrogen oxides which appear to have no serious effect at the time, frequently cause death several hours or days later. This occurred

in a number of cases in the Cleveland nitrate film disaster in 1929.

The simultaneous exposure to nitrogen oxides and carbon monoxide is particularly serious, since these gases have an additive toxic effect, the ultimate result of which is to deprive the body of its supply of oxygen. The relative toxicity of nitrogen oxides, carbon monoxide, and carbon dioxide is shown in Table II.

Safety Film Characteristics

So far, all commercial safety motion picture film supports have been made from cellulose acetate or the mixed acetate-propionate or acetate-butyrate cellu-

TABLE I†

Gases evolved in flameless combustion of nitrate film. (Volume of combustion chamber: 8 to 27 cubic ft. Weight of film: 2 lbs. per cubic ft. of chamber.)

Cellulose acetate film starts to decompose with evolution of fumes at 500 F, compared with only 200 F for nitrate film. The ignition temperature usually given for acetate film is about 800 F, compared with 300 F, for nitrate film. Our laboratory tests (Fig. 1) show the high acetyl acetate film base to ignite in 9 seconds at 950 F, and in 2 seconds at 1100 F. At 930 F the film decomposes but does not ignite in this test.

The thermal decomposition of acetate film is neither exothermic nor autocatalytic. Furthermore, the burning rate of acetate film is only about 1/20 that of nitrate film. This means that acetate film is difficult to ignite and, if ignited, is easily extinguished by water or smothering. Cellulose acetate plastics containing some of the common types of plasticizers burn about as fast as paper in the same form and quantity.

Flame-Retarding Plasticizer

However, acetate motion picture film base made by Eastman Kodak Co., contains a flame-retarding plasticizer which greatly slows down the burning. Modern

TABLE II*
Toxicity of the more important gases evolved in combustion of nitrate film.

Symptoms	Parts per Million Parts of Air		
	Nitrogen Oxides	Carbon Monoxide	Carbon Dioxide
1. Slight symptoms after several hours or maximum concentration for 8 hours exposure	30-40	100-200	5,000-30,000
2. Maximum concentration tolerated for 60 minutes without serious disturbance	50-100	450-900	33,000-60,000
3. Dangerous to life in 30 to 60 minutes	100-150	1500-2000	33,000-80,000
4. Kills most animals in short time	240-700	4000 or over	50,000-300,000

* From Jacobs, M. B., "The Analytical Chemistry of Industrial Poisons, Hazards and Solvents," Interscience Publishers, Inc., New York, N. Y., 1941 and 1949.

lose esters. It is sometimes thought that the term "safety film" implies that these films do not burn. Actually all of these safety films will burn slowly if held in a flame, but will generally cease burning soon after the flame is removed. They are called safety films because they are so very much less hazardous than nitrate film—the ignition temperature is much higher, the burning rate so much lower, and there is no danger from nitrous fumes.

safety films actually burn much less easily and less rapidly than paper or wood in the same form and quantity.

The gases given off when acetate film burns (Table III) are about the same as those given off by burning wood. Of these, carbon monoxide is the greater hazard, although the other gases may produce suffocation or even severe lung irritation if inhaled in sufficient quantity. If acetate film is burned in an ex-

TABLE III†
Gases evolved in combustion of cellulose acetate (safety) film.

Gases	Physiological Effect
Carbon monoxide (CO)	Toxic
Carbon dioxide (CO ₂)	Suffocating
Hydrogen (H ₂)	
Methane (CH ₄)	
Acetic acid (CH ₃ COOH)	Irritating and Suffocating
Aldehydes	
Ketones	
Alcohols	

† From Nuckolls, A. H., and Matson, A. F., "Some Hazardous Properties of Motion Picture Film," J. Soc. Mot. Pict. Eng., 27, 657-661, December 1936.
Editor's note: Gases present in trace amounts only are not shown in this table.

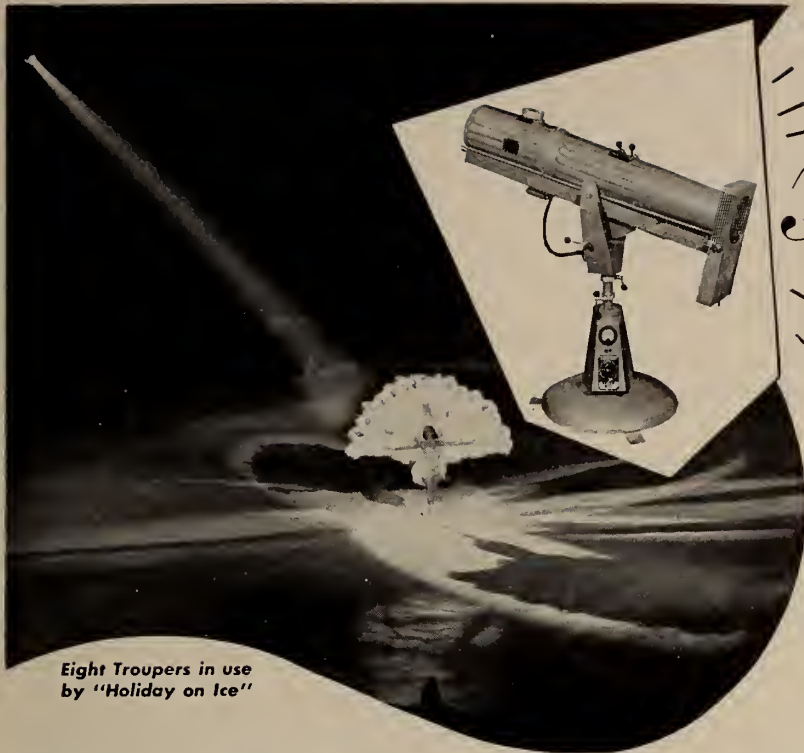

Eight Troupers in use
by "Holiday on Ice"

Flit 'em with
TROUPERS
and they
SPARKLE!

Ice shows, theatres, arenas, circuses and coliseums have been quick to appreciate the sharp, dazzling snow-white spot projected by the Strong Troupers High Intensity Arc Spotlight. Drawing only 10 amperes from any 110-volt A.C. convenience outlet, the Troupers makes the use of heavy rotating equipment unnecessary. With an adjustable, self-regulating transformer an integral part of the base, the Troupers is ideal for travelling

shows. Mounted on casters it's easily portable and readily disassembled for shipping.

The high efficiencies of the Troupers are largely attained by the optical system which utilizes a silvered glass reflector and a two-element variable focal length lens system. The automatic arc control maintains a constant arc gap, free from hiss or flicker. A trim of carbons burns one hour and twenty minutes at 21 volts and 45 amperes.

THE NEW STRONG TROUPERETTE INCANDESCENT SPOTLIGHT

... for small theatres, schools, night clubs, TV studios and industrial shows, where physical dimensions and price are factors and where the tremendous light volume of an arc lamp is not necessary.

PROJECTS FAR MORE LIGHT THAN ANY CONVENTIONAL, INCANDESCENT SPOTLIGHT

This increased brilliancy is made possible by a variable focal length objective lens system, a 5 1/4-inch silvered glass reflector, and Fresnel lens used with a standard 115-volt, 1000-watt prefocused projection type bulb. As contrasted to the conventional incandescent spotlight, with which the spot size is varied solely by iris, to result in substantial light loss, the Troupette utilizes all the light through most of the spot sizes.

6-1/2 TIMES BRIGHTER HEAD SPOTS

Sharp edges from head spot to flood. Horizontal masking control can be angled at 45 degrees in each direction. Fast operating color boomerang accommodates six slides. Height-adjustable mounting stand.

Can be plugged into any 110-volt convenience outlet.



SEE ANY OF THE FOLLOWING DEALERS OR USE COUPON FOR OBTAINING LITERATURE

ALBANY, N. Y.—Nat'l Theatre Supply Co.; Albany Theatre Supply
ATLANTA—Nat'l Theatre Supply Co.
ATLANTIC CITY—Boardwalk Film Enterprises
AUBURN, N. Y.—Auburn Theatre Equipment
BALTIMORE—J. F. Dusman Co.; Nat'l Theatre Supply Co.
BOSTON—J. Cifre, Inc.; Nat'l Theatre Supply Co.
BUFFALO—Dion Products; Nat'l Theatre Supply Co.
CHARLOTTE—Nat'l Theatre Supply Co.; Standard Theatre Supply Co.
CHICAGO—Abbott Theatre Equipment Co.; Gardner Jansen, Inc.; Hollywood Stage Lighting Co.; Midwest Stage Lighting Co.; Nat'l Theatre Supply Co.; Droll Theatre Supply Co.
CINCINNATI—Nat'l Theatre Supply Co.
CLEVELAND—Nat'l Theatre Supply Co.
DALLAS—Hardin Theatre Supply Co.; Modern Theatre Equipment Co.; Nat'l Theatre Supply Co.
DENVER—Nat'l Theatre Supply Co.; Graham Bros.
DES MOINES—Nat'l Theatre Supply Co.
DETROIT—Nat'l Theatre Supply Co.
FORTY FORT, PA.—V. M. Tate Theatre Supplies
GREENSBORO, N. C.—Standard Theatre Supply Co.
HOUSTON—Southwestern Theatre Equipment Co.
INDIANAPOLIS—Nat'l Theatre Supply Co.
KANSAS CITY, MO.—Shreve Theatre Supply; Nat'l Theatre Supply Co.
LOS ANGELES—J. M. Boyd; C. J. Holzmueller; Nat'l Theatre Supply Co.; Pembrex Theatre Supply Corp.
LOUISVILLE—Falls City Theatre Supply Co.

MEMPHIS—Nat'l Theatre Supply Co.
MILWAUKEE—Nat'l Theatre Supply Co.; R. Smith Co.
MINNEAPOLIS—Minneapolis Theatre Supply; Nat'l Theatre Supply Co.
NEW HAVEN—Nat'l Theatre Supply Co.
NEW ORLEANS—Nat'l Theatre Supply Co.
NEW YORK CITY—Nat'l Theatre Supply Co.
NORFOLK—Nat'l Theatre Supply Co.
OKLAHOMA CITY—Nat'l Theatre Supply Co.; Oklahoma Theatre Supply Co.
PHILADELPHIA—Blumberg Brothers; Nat'l Theatre Supply Co.
PITTSBURGH—Atlas Theatre Supply; Nat'l Theatre Supply Co.
SALT LAKE CITY—Inter-Mountain Theatre Supply Co.
SAN FRANCISCO—C. J. Holzmueller; Nat'l Theatre Supply Co.; W. G. Preddey Theatre Supplies

SEATTLE—B. F. Shearer Co.; Nat'l Theatre Supply Co.
SIOUX FALLS—American Theatre Supply Co.
ST. LOUIS—City Electric Co.; Nat'l Theatre Supply Co.
TOLEDO—Theatre Equipment Co.
WESTERLY, R. I.—G. H. Payne Motion Picture Service
CANADA—

Dominion Sound Equip., Ltd., Montreal, Que.
General Theatre Supply Co., Toronto, Ont.
General Theatre Supply Co., St. John, N. B.
General Theatre Supply Co., Vancouver, B. C.
General Theatre Supply Co., Montreal, Que.
General Theatre Supply Co., Winnipeg, Man.
Perkins Electric Co., Ltd., Montreal, Que.
Perkins Electric Co., Ltd., Toronto, Ont.
Sharp's Theatre Supplies, Ltd., Calgary, Alta.

THE STRONG ELECTRIC CORP.
"The World's Largest Manufacturer of Projection Arc Lamps"
14 City Park Avenue
Toledo 2, Ohio

Please send free literature on the Strong Troupette Incandescent Spotlight; Strong Troupers Arc Spotlight.

NAME _____
COMPANY _____
STREET _____
CITY & STATE _____

	Underwriters' Laboratories Limits for Approved Slow-Burning Film	Eastman Nitrate Film, Type 1302	Eastman High Acetyl Acetate Film, Type 5302	Newsprint Paper	White Ledger Paper
Thickness, inches		0.006	0.006	0.002	0.005
Burning time, sec.	65 sec. (minimum)	5	105	11	21
Flame height, inches		50	10	20	17
No of times re-ignited		0	2	0	0

cess of air, the carbon monoxide would be converted to carbon dioxide; but in a restricted air supply, some carbon monoxide would be present.

In short, the hazard presented by burning acetate film is about the same as that of burning wood, where the smoke is irritating but not dangerous unless confined in an unventilated space. It is not in any way comparable to the hazard of burning nitrate film.

Tests for Safety Film

Since all films other than nitrate might not be sufficiently free of hazard, the American Standards Association has drawn up laboratory test methods and specifications for safety photographic film designated ASA Z38.3.1-1943. According to the ASA definition, photographic films are classified as safety films if they are (1) difficult to ignite (2) slow burning, and (3) low in nitrogen content.

Results of tests made on nitrate and safety Eastman Motion Picture Positive Films by the ASA procedures are given in Table IV and show the wide differences between the two types of film.

The Underwriters' Laboratories describe approved slow-burning photographic films as follows: "Hazards in use and storage are small, being somewhat less than those presented by common newsprint paper in the same form and quantity."*

The Underwriters' Laboratories test procedures for classifying films as slow-burning differ in some respects from

* "List of Inspected Gas, Oil, and Miscellaneous Appliances," Underwriters' Laboratories, Inc., Chicago, Ill., November 1947.

	ASA Limits for Safety Film	Eastman Nitrate Film, Type 1302	Eastman High Acetyl Acetate Film, Type 5302
1. Ignition time at 300 C., minutes	over 10	0.04	Infinity (Does not ignite)
2. Burning time, seconds	45 (minimum)	9	Infinity (Self-extinguishing)
3. Nitrogen content, per cent	0.36 (maximum)	10.8*	0.02-0.05

* The nitrogen content of the un-plasticized cellulose nitrate is approximately 12%.

those of the ASA. For example, the Underwriters burning test is made on a strip of film held vertically instead of horizontally as in the ASA procedure, which is a more severe test. The Underwriters' Laboratories also measure the ignition temperature rather than the ignition time.

Comparison of Burning Tests

In Table V are the results of burning tests made by the Underwriters' Laboratories method on both nitrate and acetate Eastman Motion Picture Positive Film and on two types of paper. It may be seen that acetate film burns very slowly compared with nitrate and must be re-ignited several times. Acetate film is also much slower burning than either newsprint paper or ledger paper (which is closer to the film in thickness). Note that paper does not meet the rigid requirements of the Underwriters' Laboratories for approved slow-burning photographic film.

Soviet to Widen Film Standard?

Rumors in international technological circles have it that the Soviet government is considering changing the width of standard motion picture film from 35 to 40 mm and of constructing projectors in such a way that the different sizes of sprockets would not be interchangeable.

The reason given for the change, reports state, was the need of extra film width for stereophonic sound tracks, but the cynics think that the real reason is to make unusable naughty capitalist films without costly adjustment from 20 to 24 frames per second.

New Plastic Correcting Lens

The largest lens for a Schmidt optical system ever manufactured commercially, an essential part of theater television systems, is now being made by Polaroid Corp. at Cambridge, Mass. Designed to make a giant Tv picture, 15 x 20 feet, look as sharp as it would appear on a living room Tv set, the 22½-inch lens is cast from liquid plastic. The RCA theater Tv system using the new correcting lens is already installed in a dozen widely-separated theaters across the nation.

This new lens, based on a design by the late Dr. Bernhard Schmidt, is twice the size of any previously produced for a mass market, and its cost is described as "only a small fraction" of the cost of a similar glass lens.

Used in an observatory camera, such a lens bends the light of the stars so that a mirror can bring them to perfect focus on the photographic plate. The RCA theater Tv system uses the same



Polaroid's new 22½-inch lens for sharpening up theater Tv images.

principle in reverse to project a Tv image from a spherical mirror without distortion or imperfect focus around the edges.

The special process used requires no grinding or polishing of the lens surfaces. The process produces the required shallow curve, almost imperceptible at a casual glance, but accurate to 1/20th the thickness of a sheet of tissue paper. It is emphasized that the lens is a plastic, not Polaroid glass.

Peerless Lamp Data Sheets Available

A series of highly informative technical bulletins on Peerless carbon arc lamps is available through J. E. McAuley Mfg. Co., 554 West Adams St., Chicago, Ill. Far from the conventional type of descriptive literature, these booklets are in effect detailed instruction data covering the installation, operation and maintenance of the various units.

TABLE V

Burning tests on motion picture film made by the Underwriters' Laboratories method.

TABLE IV

Tests for safety motion picture film made by American Standards Assoc. methods.

Interference Mirrors for Projection

NUMEROUS requests from projectionists for data on interference mirrors for arc projectors, which IP printed in an issue of last Fall which is no longer available,* prompt the publication of the appended summary of this important development.

In projecting films by arc light a great deal of energy is concentrated on the small film area. The useful light is attended by heat and near-violet rays. By placing a heat-absorbing filter between the light source and the film, or by the use of interference filters, it is possible to restrict the transmission of the unwanted radiations over a limited band.

A much more complete separation between light and heat can, however, be obtained if the interference filter is arranged to reflect only the light and to transmit the infrared and ultraviolet radiations. By such an arrangement only the light is reflected in the direction of the film; the other bands of radiation penetrate through the mirror and so escape at a lower concentration by the rear.

Coatings on Back of Glass

In order to provide protection against arc sputtering, etc., the coatings are applied to the back of the glass. From 4 to 11 superimposed coatings of transparent and semi-transparent materials are used, selected so as to have alternately low and high refractive indices.

Curves of comparative effects between ordinary metallic and multi-layer mirrors indicate an astonishingly efficient and clear-cut performance for the latter over the range of the visible spectrum, with a rapid fall-off between 750 and 850 millicrons where the coatings cease to reflect. It is this ability to provide a clean cutoff of unwanted rays which is an outstanding feature of this improvement over the usual heat and ultraviolet filters.

Glass Breakage; Color Quality

Another advantage of such mirrors is that they eliminate the problem of breakage of heat-glass. Since the interference

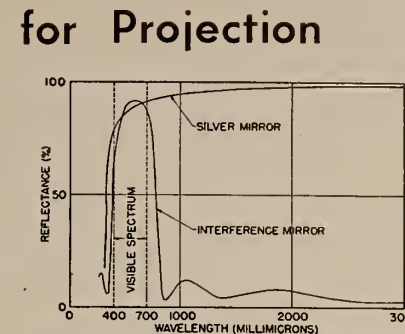

The spectral reflectance of a multi-layer interference film compared with that of the conventional silver film.

films absorb little radiation, and since they are distributed over the large area of the mirror blank, they do not get nearly so hot as a heat-absorbing glass. Actually, the absorption of infrared by the glass mirror blank itself is largely responsible for the temperature rise observed.

Probably the most important advantage these mirrors have over a silvered mirror used with a heat-absorbing glass is the control that can be attained over the color quality of the light. By proper adjustment of the thickness of the interference layers, the color of the reflected light can be varied over a wide range. This factor is of major importance for the projection of color film.

SMPTE's 69th Convention in N. Y. Week of April 30-May 4

More than 60 technical reports and discussions are scheduled for the 69th semi-annual convention of the Society of Motion Picture and Television Engineers which will be held in New York City at the Hotel Statler for five days from April 30 through May 4.

Of particular interest to the exhibition field, and especially to projectionists, will be the symposia to be held at both the morning and afternoon sessions on Wednesday, May 2. Outstanding among these sessions will be an unlimited discussion on theater screen viewing factors, the basis for which will be a report by the Screen Brightness Committee which has recently concluded an extensive survey of varying types of theaters in all sections of the country.

Reconstituted Projection Committee?

Other topics on the projection symposia agenda include new techniques and equipment, with particular stress upon their most advantageous utilization in the theater.

It is expected that an announcement of the reconstruction and revitalization of the Projection Practice Committee of the Society, long inactive, will be forthcoming shortly. The nature of these

projected changes has not been revealed.

The forthcoming convention will be marked by the usual social functions, including the semi-annual banquet and a series of activities planned for the ladies.

SMPTE Sound Group Reports

The Sound Committee of the SMPTE has investigated the possible advantages of the blue-sensitive and lead-sulfide types of phototubes for 35-mm theater and 16-mm projector use over the presently used red-sensitive phototubes. This is a continuing activity being carried on with manufacturers of color films.

At the present time, only the red-sensitive phototube is recommended as giving the best all-around performance with present day black-and-white and color sound tracks. Additional data now scheduled for collection may provide the basis for modifying this statement.

Theater Screen Deficiencies

It was brought to the attention of the committee that some recent screen installations in theaters resulted in excessive loss of volume and high-frequency response from the screen horns. The committee investigated, measured the loss of screen samples, and on finding it excessive, aided the manufacturer in modifying his fabric to reduce the sound loss to accepted values.

As the War Standard Z52.44-1945 "Sound Transmission of Perforated Screens" had never been reviewed and processed as an American Standard, the committee circulated it to all known screen manufacturers for approval. Their recent loss data all met the War Standard, and, accordingly, the Sound Committee approved the War Standard with minor revisions, and the new proposal was published in the *SMPTE Journal* for the usual 90-day trial period leading to its eventual adoption as an American Standard.

Texas Leads in New Theater Building

New theaters opened in the U. S. last year totaled 398, while 1,138 drive-ins were added to the active list during the 12 months, according to a continuing survey of the field by *The Film Daily*.

Greatest activity along the new theater line was in Texas, where 40 new regular theaters and 107 drive-ins were opened during 1950, for a total of 147 new situations for the state. California was second with 103 new houses, including 37 indoor theaters.

Complete Strong Line in New Bulletin

A new folder which illustrates and describes their full line of projection arc lamps, rectifiers, spotlights and reflectors has just been issued by Strong Electric Corp., 31 City Park Ave., Toledo 2, Ohio. Free copies are available for the asking.

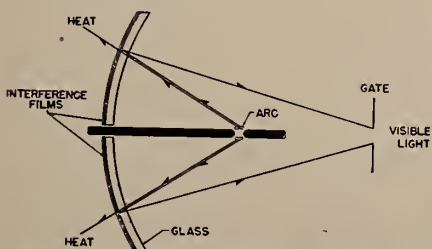

Simplified diagram showing positions of the arc, the mirror and the gate.

Theater Television

via the RCA PT-100 Equipment

By TECHNICAL PRODUCTS DIVISION, RCA SERVICE CO., INC.

V. Projectionist Operating Procedure

THE first step in placing the RCA PT-100 theater Tv equipment in operation is to apply the A-C power. After the main A-C switch on the wall has been closed, the POWER ON button on the lower left corner of the projector control panel is pushed, which lights the green pilot light. After a delay of approximately 30 seconds, the white interlock light should light, provided all access doors to the equipment are closed.

Be sure that the individual power switch on the video monitor is ON, and also that the power switch on the Tv receiver is ON, if the off-the-air signal is to be utilized.

Before turning on the high voltage, it is well to check the incoming signal to be sure that it is both adequate and free from undue noise. To do this, press the VIDEO MONITOR, VIDEO SCOPE, and AUDIO MONITOR buttons, on the signal selector panel, for either LINE 1, or LINE 2, whichever is to be used as the source of the program. If off-the-air pickup is to be used, all buttons used should be those for LINE 1.

Steps in Tuning

The Tv receiver must be tuned to the station from which the program desired is to be received. Turn the channel selector switch to the desired channel number and vary the fine control knob until the two green areas in the tuning tube are equal in size and of maximum length.

If a plug-in antenna system is used, it will be necessary also to plug-in the antenna, corresponding to the channel in use, prior to tuning.

If coaxial cable or telephone line is to be used, all buttons pushed should be those for LINE 2. Then set the oscilloscope control knob, located in the projector control panel, to its CAL position and note the height of the space between the two horizontal lines which appear on the oscilloscope screen. Return this knob to its OPERATE position. The signal pattern should have approximately the same height as the space between the two horizontal lines previously seen. This indicates that adequate signal strength is available.

Then set the BLACK LEVEL and CON-

TRAST knobs on the video monitor panel to produce the best picture. If the picture is unsteady horizontally, readjust the HOR. HOLD control as required to hold the picture steady. Observe the picture on the monitor tube to make sure it is of good quality and reasonably free from noise interference. Listen to the sound at the AUDIO MONITOR JACK to be sure it is normal.

Projector Control Knobs

If both picture and sound are normal, press the VIDEO PROJ. and the AUDIO PROJ. buttons on the signal selector panel, for either LINE 1 or LINE 2, to correspond to those already depressed. Set the control knobs on the projector control panel as follows:

METER to 80 KV;

VIDEO and AUDIO to zero;

BLACK LEVEL to point at which it normally operates, as determined by previous experience by the RCA installation supervisor.

Push the VIDEO MONITOR, PROJ. and VIDEO SCOPE, PROJ. buttons.

Rotate the VIDEO control knob on the projector panel clockwise until the picture appears on the monitor tube screen. Adjust this control to produce a normally bright picture.

If necessary, readjust the HOR. HOLD knob on the projector control panel to keep the picture steady in the horizontal direction. Do not turn this control any farther than necessary in the clockwise direction. When the picture is satisfactory, return the VIDEO knob to its zero position and press the VIDEO MONITOR, LINE and VIDEO SCOPE, LINE buttons which were pressed at first, to return the monitor and scope inputs to the incoming line.

Applying the High Voltage

Now the equipment is ready for the application of the high voltage. Push the HI VOLT ON button. The red pilot light should light. Observe the meter on the projector control panel: it should come up to a steady indication of approximately 80 Kv in three stages over a period of about 30 seconds.

Then turn the METER switch to BEAM

CURRENT and leave it in this position except when it becomes necessary to measure the high-voltage supply again. Note that the high voltage will not come in, nor will the red pilot light, if the white interlock lamp is not lighted before the HI VOLT ON switch is pressed.

Operation of the Kinescope protection circuit at any time, whether the high voltage is on or not, will cause the white lamp to go out and the high-voltage supply to be cut off, as shown on the high-voltage meter and by the extinguishing of the red pilot lamp.

Open Interlock Switches

If this occurs, the cause of the difficulty must be located and corrected before the equipment high voltage can be again turned on. Usually this cause will be found to be an open interlock switch on one of the power rack supplies, on the rack horizontal deflection amplifier, on the door of the power supply room, or on the cover of the projector barrel. Otherwise it may be a defective tube in one of the deflection amplifiers, in one of the 400-volt power supplies, in the 300-volt regulator, or in the projector barrel. The same trouble could also result if one of the plugs in the projector barrel should become loose.

To make the changeover, after the film is finished, switch the sound system special input switch over to the Tv projector line. At the Tv cue, turn the VIDEO and AUDIO control knobs on the projector control panel clockwise until the sound level, as indicated on the sound system monitor, is normal and the picture brightness equals that normally expected as determined by previous experience.

Black Level Control

Slight readjustment of the BLACK LEVEL control on the projector control panel may be necessary and should be made as required to maintain normal blackness of the black portions of the picture, and to prevent retrace lines from appearing on the screen.

The VIDEO MONITOR and SCOPE PROJ. buttons may be pressed to show the picture quality and the signal amplitude at the projector barrel, instead of on the incoming line, if desired, or if the picture quality on the theater screen does not seem to be equal to that on the moni-

tor. This checks the operation of the amplifiers and connections up to the projector barrel.

Beam Current Meter

The projectionist must exercise care not to turn the VIDEO control too high, as this causes loss of picture quality and definition on the theater screen. The average indication of the BEAM CURRENT meter should be approximately one milliampere; but this will change with picture content changes. If a picture is composed of mainly white areas, the beam

current may be considerably higher than the average value; if the picture is mainly dark areas, the beam current will generally be less than the average value. It will normally fluctuate during the performance.

Post-Tv Show Procedure

After the Tv program is over, rotate the VIDEO and AUDIO controls to zero—this takes the picture off the screen and shuts off the sound. At the same time the monitor and scope will also lose picture and signal voltage if they are being fed from the PROJ. buttons. Switch the

sound system special input switch back to the film projector position, and the sound system will then be ready to run film. Turn off the high voltage by pressing the HI. VOLT OFF button. Then turn off the main power by pressing the POWER OFF button, and turning off the main AC switch on the projection room wall.

If the incoming signal is not taken from the Tv receiver, this unit may be turned off with its individual power switch, located near the right end of the Tv receiver panel. Then the receiver tubes will not be used when not necessary. It is recommended, however, that the video monitor panel switch be left on at all times when the projector is in use, with the video monitor switched to LINE position. Thus the quality of the projected picture may be continuously compared with the quality of the monitor picture. This enables the projectionist to determine whether observed picture defects are due to projector faults or incoming signal defects.

Tube-Testing Switch

The 300-volt regulator panel is provided with a tube-testing switch. Rotation of this switch to any of its first eight positions enables the projectionist to check each of both plate currents of the four regulator tubes. The last two positions, 9 and 10, indicate the total output current of the regulator and its output voltage, respectively. However, the total current is actually 10 times the meter indication, therefore, it is necessary to multiply the meter indication by 10 to obtain the actual current value. Also, the meter indicates only half the true voltage, therefore it is necessary to multiply the indicated voltage by 2 in order to obtain the actual output voltage.

These procedures are necessary because the meter scale could not be made high enough to indicate the total current without having the individual tube currents very low on the scale. The voltage indication would also be off-scale if the meter scale indicated the voltage directly.

[NOTE: The sixth and concluding article in this series will appear in the next issue.]

Plan Review of NPA Order M-4

The possibility of amending NPA Order M-4, which placed serious restrictions on any expansion program, in both building and new equipment, brightened considerably when it was announced that the members of the Industry Advisory Committee will meet in Washington on April 25 to discuss the over-all impact of Order M-4 on the motion picture industry.

Strenuous opposition to Order M-4 has developed in the industry, and it is possible that they may be able to effect an easing of its provisions.

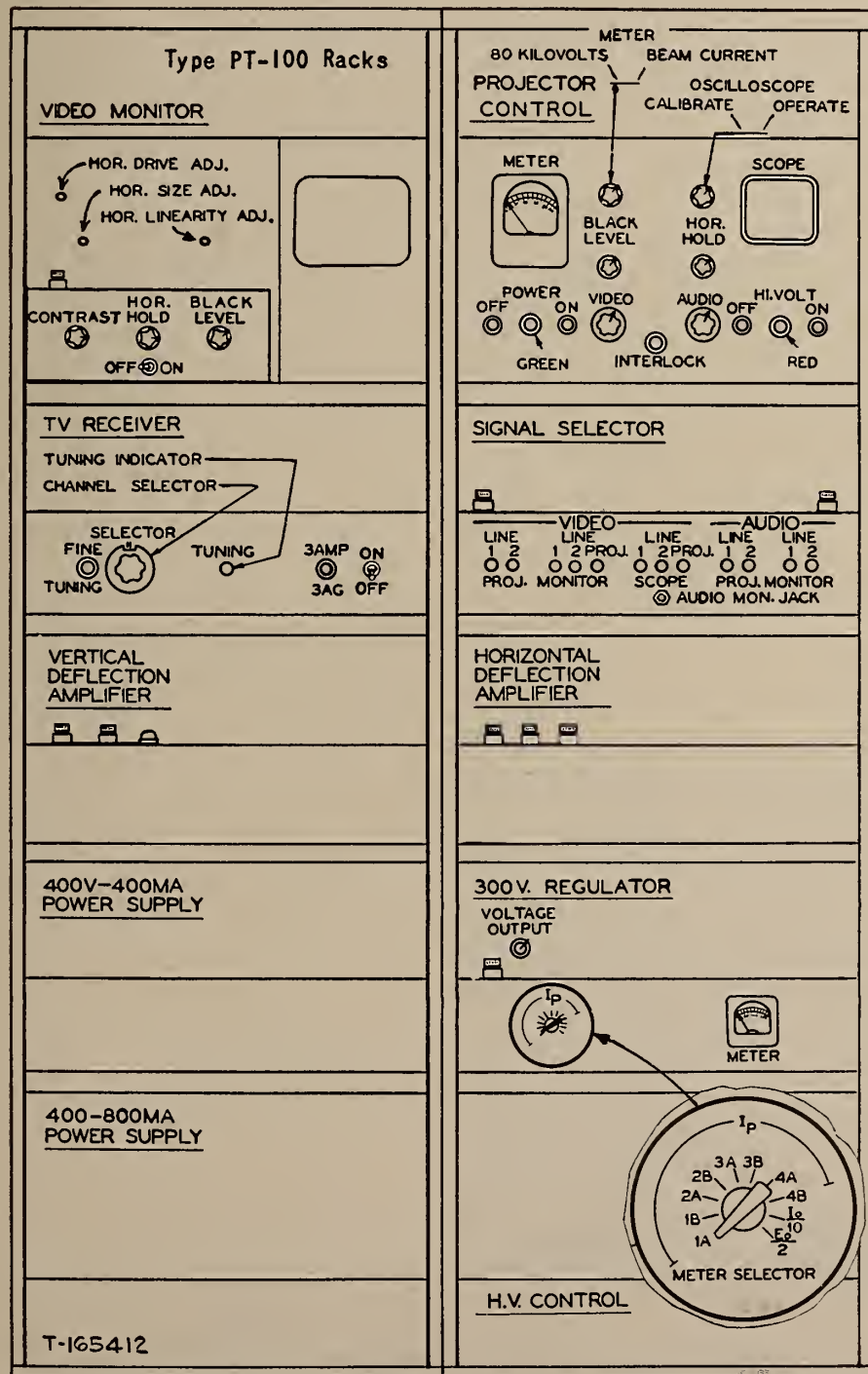

Figure 1 - Operating Controls on Theatre Television Projector

IN THE SPOTLIGHT



By
**HARRY
SHERMAN**

NOT a little space in this department has been devoted of late to the social security aspirations of organized labor, and in particular our own craft. But there is another form of security which is receiving ever-increasing attention from both labor and management—union security.

The importance of this topic is pointed up by a series of articles under the heading "The Labor Angle" now appearing in the magazine *Business Week*, the prime concern of which is Big Business.

The first of this series of articles states flatly that the next big issue in labor relations is "an old one revived. Its generic name is 'union security.' It reaches new and compelling importance now because (1) a long-term trend is coming to a climactic point; (2) some strange fruits of the Taft-Hartley act are being harvested; and (3) mobilization pressures are upsetting the always delicate equilibrium of the union-management balance."

Theme of the article is that the term "union security" is concerned with the "basic power factors in the union-management equation"—not with wages, hours, or even fringe benefits and pensions. Boiled down, the issue concerns that which unions have to offer their members, on the one hand, and what the

union has to offer management, on the other hand. The stakes are the predominant control over the individual worker.

We don't suggest that every union man rush to buy *Business Week* for this series of articles, but we hold that they should be required reading for labor leaders in the higher echelons.

- An item that appeared in the N. Y. *Times* several weeks ago relative to the pension plan of the UAW (CIO) interested us greatly. Ben O. Miller, tool-maker for the Packard Motors for the past 35 years, retired recently upon reaching his 65th birthday. As a member of Local 190 (UAW), Miller now receives a monthly pension of \$112.70, including U. S. social security benefits to which he is entitled. Death benefits of the UAW union are \$1000 per member.

Contrast this with the pension and death benefits now in force in two of the larger IA Local Unions—New York Local 306 and Chicago Local 110. Retiring members of Local 306 receive a weekly pension of \$30, with a death benefit of \$4000 per member; Local 110 men receive a pension of \$100 per month, and the death benefit is \$2000 per member. The pensions of both these IA Locals are *exclusive* of social security or any other income. We should like to point out here that the New York Local

has approximately four times the membership of the Chicago Local, with a correspondingly larger intake, hence the slightly higher benefits.

Pension benefits of the UAW union suffer by comparison with the *unrestricted* benefits enjoyed by the aforementioned IA Locals.

- Pine Bluff, Ark., Local 327 observed its 37th anniversary breakfast at Johnsey's restaurant, Pine Bluff, on April 6. Highspot of the celebration was the presentation of a gold life membership card to Barney N. Burke, charter member of the Local and one of its organizers. Burke was taken completely by surprise, for all plans of the affair were kept under cover until the very last day, when Mrs. Burke persuaded him to accompany her to the restaurant under some pretext or other.

In addition to the membership, which turned out en masse, present were W. P. Raoul, IA secretary-treasurer, representing the General Office; and officers and members from a number of out-of-town Locals. Among the invited guests were the Mayor of Pine Bluff, George H. Steed; Ira Baldrige and Jack Shoemaker, Little Rock Local 204; E. C. Price and Rufus McMoran, Hot Springs Local 326; J. Fitzgerald, Texarkana, Texas Local 383; W. A. Griffin and L. E. Hurt, Memphis, Tenn. Local 144.

- The problem of one-man operated projection rooms has come up again to plague Vancouver Local 348. Exhibitors in the Local's jurisdiction, covering an area of 500 miles, have again raised the issue in the legislature, presenting arguments against the existing two-man operation. Local 348 officials are putting up a determined fight to retain prevailing conditions.

- We had the privilege of attending the regular March meeting of Westchester County, N. Y. Local 650, and we came away with the thought that here was a group of men working for a common goal—to make their Local a truly 100% cooperative organization.

Anthony (Tee Dee) Dente, 1st vice-

BARNEY N. BURKE, VETERAN OFFICIAL, HONORED BY LOCAL 328, PINE BLUFF, ARK.



Acting for the Pine Bluff Local, General Secretary-Treasurer Wm. P. Raoul presents Barney N. Burke, its secretary-treasurer for many years, with a gold life membership card. Looking on may be seen (l. to r.): Herman E. Zappe, bus. rep.; George B. Finley, sgt.-at-arms; V. V. Vaught, pres.; Raoul, Burke, Lewis Hill, vice-pres., and Everett Stanley, trustee.

MICHAEL NUGENT AT CHESTS' PANEL



Addressing a panel of the Mideast Regional Conference of Community Chests and Councils at the Hotel Statler in New York City recently, Michael J. Nugent, secretary of Westchester County (N. Y.) Local 650, stressed the important role played by wage earners in the various Community Chest campaigns throughout the country. Nugent told of the cooperation of the AF of L with these campaigns, and cited the Russell Sage Foundation report for 1943 which showed that wage earners contributed between 25 and 30 per cent of all monies collected by voluntary causes.

president of the Local, was awarded a gold life membership card for his seemingly tireless efforts on behalf of the members. Another highlight of the meeting was the presentation of gold wrist watches to each member of the official family, the presentations being made by Louis Goldshlag, Bernie Rich, and Joe Monaco (business representative of Westchester County Local 366). Invited guests at the meeting included the officers of sister Local 366—Nathan Storch, James Maloney, Morris Steinberg, Joseph Yans, and Joe Monaco, all of whom were warmly welcomed by the membership.

• Up from the ranks is the Horatio Alger story of Dominic Paduano, the new Commissioner of N. Y. City's Department of Water Supply, Gas & Electricity, supervising all electrical installations backstage and projection room operations. Paduano still retains his membership in IBEW Local 3, N. Y. City, and understands the problems that confront our boys both backstage and in the projection rooms. From a working electrician to the post of Commissioner of one of N. Y. City's largest and most important departments is quite a feat in any man's life.

• George Raywood, business representative for Local 316, Miami, has earned the gratitude of many IA men from all parts of the country who spend their winter vacations in Florida. His consideration and concern for the well-being of these visitors to his part of the country have won for him a host of friends throughout the Alliance. We personally know of

scores of men who returned to their Locals deeply grateful for his many kindnesses.

• The National Labor Relations Board in Washington, D. C., recently ruled that a union with a union-shop contract can cause the dismissal, without risk, of a person labeled pro-Communist. Heretofore under the Taft-Hartley Act, a union could not compel an employer to discharge a man except for non-payment of union dues. Organized labor contended that this restriction on the union shop permitted management spies, trouble-makers, Communists, etc., to stay on the job as long as they paid their union dues. This latest ruling involved a Washington manufacturer and a union member who was accused of signing the Communist-sponsored Stockholm peace pledge.

• The 40th anniversary banquet of Local 203, Easton, Penna., will be held at midnight Thursday, May 10 next at the Forks Township Tavern.

• IA President Walsh was the guest of honor at a dinner sponsored by the motion picture industry at the famous "21" restaurant in N. Y. City on April 10, in recognition of his contributions to the Will Rogers Memorial Hospital, of which Dick is a vice-president and member of the board of directors. Bob O'Donnell, general manager for the Interstate Circuit of Texas and president of the hospital, was toastmaster.

Practically all the circuit and major film company executives turned out to honor Dick, making the event a most auspicious one in that this is the first time in history of our Alliance that an

IA president was so honored by the men "on the other side of the fence."

• Toledo Local 228 lost another of its older members—Carol W. Laycock, who died March 31 last. One experiences many a pang at the passing of these old-timers: they worked unselfishly for those who followed them.

• Returning from a trip to the West Coast, Bert Ryde business representative for Buffalo, N. Y. Local 233 (and Mrs. Ryde) stopped off for a visit at the beautiful new clubhouse of Local 279, Houston, Tex. Gracious hospitality is second-nature to the Houston boys, of course, but Bert relates that his reception there ranked as an all-time high in how to do things right.

• Projectionists have long desired that their own Projection Practice Committee of the SMPTE have as a chairman a practical projectionist. The SMPTE has recognized the import of this request by the craft by naming as committee chairman M. D. (Obie) O'Brien, assistant director of visual and sound projection for Loew's Theaters.

• The purchase of an additional \$100,000 U. S. saving bonds by Chicago Local 110 brings the total to \$375,000 such bonds purchased within a 2½-year period. The money was taken from the Local's welfare fund, which provides employer-paid pensions, vacations, sickness and death benefits for its members. "We are glad to put this money where it will do the most good," said Gene Atkinson, business representative for Local 110. "Although we are a relatively small or-

WESTCHESTER COUNTY (N. Y.) LOCAL 650 HONORS ITS OFFICIAL FAMILY



In appreciation for their unselfish services to the membership, Local 650, Westchester County, presented its officials with beautifully engraved gold wrist watches. Shown here holding the gifts are, bottom row (l. to r.): Fred Thome, bus. rep.; Anthony Dente, 1st vice-pres.; I. A. Weiss, pres., and Albert Storch, 3rd vice-pres. Top row (l. to r.): Michael J. Nugent, rec.-cor. sec.; Joseph A. Schappach, fin.-sec. treas.; Donato De Palo, trustee; Patsy Colarusso, 2nd vice-pres., and Albert E. Bell, trustee. Local 650 covers one of the largest areas in the IA.

ganization, our bond purchases per member are probably the highest in the country. Our welfare fund is in good shape, and we have \$200,000 in reserve."

- During a recent visit to the State Building in lower Manhattan, we dropped in the court room presided over by Nathaniel Doragoff, former secretary for New York Local 306, who is now serving as a referee for the N. Y. State Department of Compensation. Doragoff's handling of the various cases impressed us very much, and we predict he will attain even higher levels in his profession.

- E. Clyde Adler, president of Detroit Local 38, was reelected president of the Michigan Alliance, IATSE. A welfare plan, including hospitalization and disability benefits for Alliance members, is now being discussed with several of the larger circuits.

- Frank Constantino, member of Local 362, Paterson, N. J. for the past 30 years, was recently appointed by the Mayor of Paterson to serve on the city's Plant Management Commission for a four-year term. This Commission supervises the operation of the city-owned electric power plant and other municipally-owned projects.

- Strong opposition of New Hampshire theater exhibitors to a bill introduced by Senator Sara E. Otis, calling for a three-man commission to examine and license projectionists, stifled the measure when it was brought before the State legislature. Under the proposed bill the license fee for projectionists would have been \$10 for the first year, and \$5 per year upon renewal.

- All unions participating in the "Bob Hope Night on Broadway" show, held at the Paramount Theater, N. Y. City, on April 9 for the benefit of the Damon Runyon Memorial Fund, donated the services of their members to this worthy cause. Projectionists' Local 306 and Stagehands' Local 1, IATSE; AFM Local 802, and AGVA Local 1 participated.

- Herbert K. Sorrell, business representative for Local 644, Painters, Paperhangers and Decorators of America, and leader of the 1945-46 strikes in the West Coast studios, was "sentenced" by a trial board of the Painters International Brotherhood, AF of L. barring him from holding any union office for five years because he "wilfully and knowingly associated himself with organizations and groups which subscribe to the doctrines of the Communist party." Significantly, Sorrell was reelected and given a vote of confidence by Local 644—which happening undoubtedly presages a fight with the International.

- Joe Reilly, former business representa-

Ray Brian's Fine Collection of Film Projection Lore

One of the finest collections of historical data anent the motion picture projector, and the projection process, has been accumulated over a period of many years by Ray Brian, of Peoria, Illinois. Ray's collection consists of 13 scrapbooks of material which include data on 212 different makes of projectors, including photographic records of 141 of them.

Of the known makes of projectors Ray has 338 photographic records of the various models, many hundreds of patent papers relating to projection—not a few of them humorous in the extreme in that they are fantastic—and hundreds of other pieces of historical literature. The collection is enhanced by books on projection ranging back

to 1910, and Ray is now seeking editions 4 and 5 of F. H. Richardson's Handbook.

Ray's hunting ground extends around the world, but the most valuable assistance has come from G. W. Dunston, Norfolk, Va.; A. B. Jefferis, Piedmont, Mo., and the late Jack Peyton of Oklahoma City, Okla. Real relics in his possession are a positive print of "The Great Train Robbery," a Selig Polyscope dating back to 1897, and a Jenkins Phantoscope.

A member of the IA since July, 1914, Ray has been on the job at the Palace Theater, Peoria, for the past 23 years. Married and the father of two teen-agers, Ray lives at 722 West Maywood, Peoria. He would welcome hearing from anyone who has or is interested in historical projection material.

Combination photo-lab and office (at left) wherein Ray Brian experiments and maintains world-wide contacts which have gained him international recognition. At the right is the projection room of the Palace Theatre, Peoria, Ill., where Ray has worked for the past 21 years.

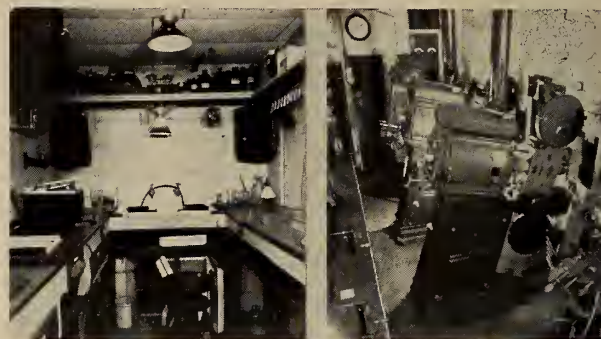

tive for Stagehands' Local 1, N. Y. City, is very proud of his artist son, Frank, who is nationally-known for his paintings and magazine illustrations. In addition to his private work, Frank Reilly teaches a class of 260 students at the N. Y. Art Students' League and holds classes at two other art schools. Artistry and business acumen—a unique combination.

25 Years Ago—April 1926

- New headquarters for the General Office now located at 1400 Broadway, N. Y. City. . . . The 28th IA Convention was scheduled for the Hotel Winton, Cleveland, Ohio, the week beginning June 21. . . . Local Unions in various localities were advised to affiliate with State and Central bodies of the AF of L, in accordance with Article 2, Section 8,

IA ELECTION

LOCAL 164, MILWAUKEE, WIS.

Glenn C. Kalkhoff, *pres.*; Oscar E. Olson, *bus. rep.*; Walter A. Behr, *vice-pres.*; Robert Lucht, *rec. sec.*; George Brader, *treas.*; August Mommer, *sgt. at arms*; John Black, Norman Habersat, Charles Beggs, Irvin Rotter, *exec. board*; Olson, Kalkhoff, Behr, *del. IA Convention*; Kalkhoff, Olson, *del. Wis. State Federation of Labor Convention*; Olson, Kalkhoff, Walter Plato, George Harris, Chester Millis, *del. Federated Trades*.

Page 41 of the International By-Laws. Failing to do so would make a Local subject to a \$50 fine. . . . New England District (3rd) Convention was held in Manchester, N. H., April 25, 1926. . . . Road call effective against the Grand Theater, Morgantown, W. Va. . . . All Locals were requested to furnish the General Office with information pertaining to wage and working conditions.

PERSONNEL NOTES

RICHARD M. WILSON has been appointed superintendent of the film emulsion coating division at Eastman Kodak Co. Joining Eastman in 1931, Wilson has specialized in coating processes.

JOHN K. HILLIARD, chief engineer for Altec-Lansing Corp., left New York on March 30 for a six-week trip through Europe for the purpose of surveying the development of microphones and loudspeakers.

LINCOLN V. BURROWS, now with Eastman Kodak Co., has been named a consultant to NPA's motion picture division. During World War II Burrows was in the photographic section of the WPB.

BASIL T. WEDMORE, recording engineer for Western Electric in London, England, for more than 21 years, has arrived in New York to assume duties as commercial recording engineer with Westrex Corp.

IA-IP Radio Contest Results

SEVEN widely-separated states, from California to New York, were represented by the ten winners in the first IA-IP amateur radio contest during the week of January 8-13, with the mid-Western men making the best showing. The list of contest winners appearing elsewhere on this page shows the first-prize winner to be Jim Evans (W0GSW) of Local 242, Pittsburgh, Kansas.

Amos Kanaga (W6BAA), secretary of San Mateo, Calif. Local 409, was the inspiration for and a tireless worker in compiling the results of the contest. Amos is also responsible for the ever-growing list of IA amateur radio men which appears in these pages from time to time.

While Amos feels that the contest was a success and more than worth the effort involved, he regrets that the weather during the week selected was, in his words, "a stinker" and militated against an even greater success. Additionally, many contestants did not mail in their log sheets in time to be considered for an award, and some others sent no log sheets at all.

One very beneficial result of the contest was that it enabled many additions to the "ham" list of IA men which is published in IP. Amos asks that when IA men work their brother craftsmen they direct notice to this list in IP and urge them to have their names added thereto.

Many of the contest participants worked their first IA contact, reports Amos. "Whenever the band opened up, especially on 10 meters, there were IA men on the air," Amos added. "Most

of the boys hovered around the 28,850 frequency and passed the word along when a new IA station was worked or heard. After midnight, 75 meters was fairly active."

Jim Evans, winner of the top award, works at a big drive-in theater for seven or eight months of the year, and in the winter months he works at theaters in town as an extra man. At the drive-in theater Jim takes care of all the sound equipment.

Started in 'Spark' Days

Jim started in radio as a youngster in the "spark" days, and was very active on 160 before World War II. Since then he operates on all bands through 10 meters. During the war he worked for the Army Air Force on transmitters, receivers and radar.

Pictured herein is Jim's last "ham" set; but at present he is using a Collins 32V2 transmitter with 100 watts input and a Collins 75A1 receiver. Jim recently moved out into the country, and there he uses a 60-foot windmill tower rotary beam on 10 meters, a rotary dipole on 20, and Donplett on 75 and other bands. He belongs to DXCC, has a WAS and

IA-IP 'Ham' Winners

W0GSW	James Evans L. 242, Pittsburgh, Kans.
W0BSO	Donald Atherton L. 191, Cedar Rapids, Iowa
W2CYQ	Frank Larham L. 108, Penn Yan, N. Y.
W5OQJ	Norman Olstad L. 279, La Porte, Texas
W3KNY	Harris Good L. 661, Reading, Penna
W8BYT	Leonard Grazier L. 388, Youngstown, Ohio
W5DYV	Bob Belian L. 604, Corpus Christi, Texas
W6PFF	Frank Champlin L. 150, Garvey, Calif.
W0JKU	John Cresap L. 242, Pittsburgh, Kans.
W0BVO	Paul Hunter L. 191, Cedar Rapids, Iowa

WINNER OF THE FIRST IA-IP AMATEUR RADIO "HAM" CONTEST



Jim Evans (W0GSW) member of L. 242, Pittsburgh, Kans., utilizes this set-up to contact not only hundreds of brother "hams" throughout the U. S. but also in many foreign lands.

Representation of certificate awarded first-place winner Jim Evans in the IA-IP amateur radio contest. Ten such certificates (in color) signed by IA President Walsh and Harry Sherman, for IP, will go to the various contest winners.



WAC, a first-class telephone license and, of course, a Class A "ham" license. He has worked practically every foreign country.

Additional listings of IA amateur radio men can be cleared through Amos Kanaga, 262 Westland Ave., San Mateo, Calif.

Current IA-IP
Radio Listing on
Next Page

Current IA-IP Amateur Radio Listing

CALL	NAME	LOCAL NO.	W5IIP			
W1BCE	C. J. Crowley—L. 459		W5DYY	Pat Talbot—L. 249	W7GXN	Edwin McMurray—L. 180
W1EBO	Woodrow Guile—L. 459		W5CQ	Paul Belian—L. 604	W7IJJ	Donald Johnston—L. 401
W1LW	Norman Soules—L. 459		W5CQQ	Ray J. Morrow—L. 597	W7AVM	J. Elmer Newell—L. 429
WINZE	Arthur Madsen—L. 182		W5IMT	Rajmunt J. Machu—L. 597	W7JTM	J. Allen Evans—L. 294
W1BHJ	Otto Halquist—L. 182		W5ODA	A. S. Johnstone—L. 293	W7OAS	George Olson—L. 294
W1WI	Tom McNamara—L. 505		W5OQJ	Bill Couse—L. 450	W7KMO	James A. Furr—L. 294
W1BVB	Don Fancher—L. 439			Norman Olstad—L. 279	W7FTV	Lloyd J. Hagaman—L. 240
W1IYY	Harold Wyman—L. 96		W6BAA	Amos Kanaga—L. 409	W8VDP	Jack Harwood—L. 160
W1JBU	George Gravell—L. 96		W6UZA	Malcomb Keele—L. 150	W8BYT	L. Grazier—L. 388
W1BTW	J. Roland Lizotte—L. 546		W6DPU	Roy Brann—L. 150	W8NS	Carl Bacon—L. 199
W1JWN	Theodore Kahn—L. 86		W6PFF	Frank Champlin—L. 150	W8WSL	Denzel Murphy—L. 239
W1KKJ	Howard Bruya—L. 505		W6PQS	Joe Wilson—L. 504	W8OWK	Edw. Miller—L. 199
			W6ALO	Tom Jentges—L. 504	W8EEW	Muriel Murtagh—L. 291
W2TSN	Victor Bufis—L. 365		W6GTP	E. Schwartz—L. 695	W8QIX	F. W. McDonald—L. 199
W2WZX	Erich Pattky—L. 244		W6MTO	Leroy Wardel—L. 762	W8QFK	Jim Robinson—L. 64
W2CYQ	Frank Larham—L. 108		W6DYJ	Ed Pothier—L. 215	W8BWU	James T. Smith—L. 100
W2ARP	Fred Ramhorst—L. 534		W6V6V	Delos Trim—L. 297		
W2NFU	Sydney Trisch—L. 306		W6RKB	Bob Gillespie—L. 241	W9NLP	Rolly Long—L. 110
W2RUA	Hugh Newcomb—L. 462		W6YWC	Lewis Howard—L. 162	W9OL	W. P. Atchison—L. 323
W2QYQ	Alfred Beckett—L. 462		W6EFL	A. H. Whitney—L. 150	W9NPG	John Bain—L. 323
W2VSQ	Frank Tamborel—L. 306		W6EAQ	E. L. Kline—L. 150	W9LBL	R. B. Connelly—L. 110
W2OCL	Edward Ricca—L. 306		W6CAG	August De Grazia—L. 150	W9EDW	Harold Nelson—L. 221
W2MYI	Mike Revzin—L. 306		W6CYW	Frank Hemerlein—L. 150	W9RTA	Herb Kleinbeck, Sr.—L. 110
W2ORS	Charles Roop—L. 418		W6KNI	Cliff Schwander—L. 150	W9FOL	Merrill Smith—L. 110
W2DZA	Alex Knight—L. 353		W6REH	Harry Gould—L. 150	W9AZA	Kenneth Mass—L. 721
W2AOM	Jack Garritson—L. 306		W6BPT	Roy Pinkham—L. 431	W9GQD	Clarence Hawkins—L. 263
W2NAJ	Peter Hurgon—L. 306		W6FBW	Frank Amarantes—L. 431	W9DBY	Kenneth G. Alley—L. 421
W2AMB	Fred Huff—L. 306		W6WPG	Robert Hyde—L. 796		
W2ZCE	John V. Richards—L. 1		W6IDY	Dom Lucido—L. 241	W0VGC	H. F. Heckel—L. 230
(formerly W3JAX)			W6EP	Leslie Hewitt—L. 695	W0ZIM	M. Geiskieng—L. 230
W2RQZ	Frank Lipinske—L. 337		W6HK	Frank Creswell—L. 728	W0GSW	James E. Evans—L. 242
W2HRJ	Charles Beckett—L. 462		W6YDU	C. R. Putnam—L. 490	W0JKU	John Cresap—L. 242
W2BOR	William Axton—L. 524		W6BWI	Harry Morse—L. 297	W0UOP	Clair Rockholz—L. 286
W2HWF	Albert Dietricht—L. 306		W6VTX	Ralph Addy—L. 521	W0WSH	Herschell Allredge—L. 443
W2BDK	Lloyd Matteson—L. 290		W6EIR	Leroy Ward—L. 521	W0DOL	E. M. Karcher—L. 482
W2PVB	Kenneth H. Allfrey—L. 290		W6ZOK	Max Miller—L. 521	W0SJK	O. S. Key—L. 219
W2HP	Jack North—L. 640		W6FGV	Norman Owens—L. 521	W0SLV	Walker Faussett—L. 395
			W6BEP	C. C. Applegate—L. 187	W0BTT	R. R. Kerwood—L. 586
W3KNY	Harris Good—L. 661		W6WPG	Robert Hyde—L. 796	W0WHV	Max Hollingsworth—L. 465
W3MEY	Leo Foran—L. 335		W6ZEN	Floyd McPherson—L. 709	W0BVO	Paul Hunter—L. 191
W3BBV	Nelson Stover—L. 283		W6FOP	George Abrams—L. 297	W0QI	E. D. Van Duyne—L. 191
W3JMA	Ralph Rushworth—L. 181		W6AGN	Arthur Hansen—L. 297	W0BSO	Don C. Atherton—L. 191
W3PMY	John Nordine—L. 296		W6EWU	Tom Wells—L. 297	W0GFN	Ira Hasket—L. 491
W3MHE	Charles Gibson—L. 444		W6YBC	Hansen Cresap—L. 297		
W3BJ	Al Edwards—L. 307		W6ZBX	George Kiaser—L. 297	CANADA:	
W3RXT	Bernard Rask—L. 171		W6CZK	Ray Baumann—L. 434	VE3ABV	Jack Snider—L. 173
W3TVM	Harry Drew—L. 171		W6CML	Tom Moore—L. 169	VE3BAK	F. Winkle—L. 173
			W6IYT	L. H. King—L. 796	VE3BVC	E. H. Whyat—L. 173
W4BWN	Bob Cobble—L. 405		K6CH	H. H. Quackenbush—L. 510	VE3BVG	Lou Lodge—L. 173
W4HJC	Arlie Belflower—L. 225		W6CCF	Charles Busby—L. 599	VE3DBF	M. Winslow—L. 461
W4MCT	Jim Davis—L. 552		W6HUE	Homer Elias—L. 599	VE3OG	H. Horner—L. 173
W4NOM	Buddy Rogers—L. 225		W6UVO	Edward Ives—L. 150	VE3TE	Tom Burrows—L. 173
W4PKT	M. H. Sanders—L. 507		W6WER	Clarence Woerth—L. 150	VE3APR	Harry McClelland—L. 582
W4CIU	Bill Britton—L. 537		W6RN	Lynn Bradshaw—L. 162	VE5JK	Jack Kyle—L. 295
W4FGG	Marvin Storler—L. 144		W7LAT	Fred Jones—L. 720	VE7OT	M. Thoreau—L. 348
W4RFF	Howard Ross—L. 574		W7PEC	Jim Harford—L. 720	VE7US	C. Moorehouse—L. 348
W4RMT	E. M. Karcher—L. 482		W7AXY	John Murphy—L. 91	VE7MN	C. H. Richards—L. 348
W4KBJ	James File—L. 290		W7ALM	Chester Lamont—L. 446	VE3AYQ	Cecil D. O'Neill—L. 461
W4MEP	J. Wyatt—L. 793		W7FJZ	Z. A. Sax—L. 159	VE5RJ	Ron Marchant—L. 300
W4FGK	D. Holye Knight—L. 412		W7HE	Dee Hart—L. 91	VE3AHJ	Walt Mann—L. 467
W4DPT	Adrian McCroskey—L. 446		W7HPF	John Gilbert—L. 91	VE7ALW	Merle Wilson—L. 348
					VE7APN	Jack Stone—L. 348
					VE7APU	Tom Hepple—L. 348
					VE7BJ	Edward S. Brooks—L. 348

[NOTE: Additions and corrections should be sent to AMOS R. KANAGA (W6BAA), 262 Westland Ave., San Mateo, Calif.]

Simplex Honors 50-Year Employee

MEMORIES of the early days of motion pictures were evoked at a dinner tendered recently to honor Charlie Linderer on the occasion of completion of 50 years continuous service with International Projector Corp., makers of Simplex visual and sound projection equipment.

Charlie Linderer got his first job in 1901 with Nicholas Power, who at that time was servicing motion picture equipment in a small loft at 115 Nassau St., N. Y. City. The "staff" consisted of Power's daughter in the office, a mechanic, and Charlie, who, in addition to running errands, dabbled in filing castings, drilling and tapping holes.

At night Power showed pictures in social clubs, churches, schools, halls, etc. Charlie assisted by carrying the mechanism mounted on a tableboard, while Power toted the accessories—telescoped legs, reels and reel-hanger and the screen. Extreme portability was the first requisite, since practically all transportation was done by trolley cars.

Projection Circa 1901

Screen illumination was supplied by a calcium burner *via* a line fed by oxygen and hydrogen tanks, delivered to the exhibition hall by the company which supplied the gases. A piano player arrived under his own momentum. It was important that the screen be hung without wrinkles, and Charlie says that this was the most tedious part of the job. The projector was generally set up in the middle of the aisle.

The reel of film was clamped to the top of the mechanism by the reel-hanger, and the film passed through the mechanism into a bag fastened to the tableboard. The machine was hand cranked, 10-inch

reels were used, and there were no magazines. When the reels were empty, the film was hung on the reel-hanger. While rewinding the film, the lamphouse was moved over to the side and stereopticon views shown until the next reel was ready for screening.

Servicing projectors and showing pictures gave Nicholas Power ample oppor-

50-YEAR EMPLOYEE FETED BY IPC



Admiral R. B. Tompkins (Ret.), president of International Projector Corp. presents an appreciatory scroll to Charles Linderer on the occasion of the latter's 50th year of consecutive employment with the company.

tunity to see in a very practical way the very serious defects of the many crude machines in use about 1900. An excellent mechanic, he patented many improvements which were later incorporated in the Peerlescope, his first projector. Power was also a smart business man as well as an inventor, and in the course of the years brought out many models of his projector under the name "Power's," which he later made famous.

When the "gold rush" days came, the period during which many people ex-

pected to cash in on the motion picture craze by showing pictures in halls, stores, and 299-seat "theaters," Power's business expanded tremendously to the point where he was occupying a large factory on the lower East Side of New York, the address which was to become world-famous in projection circles as "92 Gold St."

Delivery 'on One's Back'

Charlie recalls how the demand for projectors became so great that prospective theater owners would call at 92 Gold St. and personally carry away the machines. The "boom and bust" cycle which plagues every new industry flattened many of these entrepreneurs economically, but not a few of the pioneers prospered and went on to found some of the biggest producing and exhibition companies in the industry.

Charlie's early experience made him realize that the failure to include even the smallest projector part, or to have it mislaid or damaged in transit, might delay the opening of a theater. Such an event could be disastrous to an owner working on limited capital; and Charlie has never forgotten this lesson in all the years that he has headed the packing and shipping department of IPC.

In 1925 the Nicholas Power Co., makers of Power's projectors, and Precision Machine Co., which made the Simplex mechanism, were merged into International Projector Corp., and Charlie Linderer was considered one of the most valuable human assets. Today there are 27 employees with 25 or more years service with IPC.

Charlie saw the cycle completed when he was presented with a 17-inch TV set, along with a beautifully executed scroll of appreciation.

The famous Powers No 6 Cameragraph (1909) having a solid-pin movement and employing the then conventional straight arc for illumination.

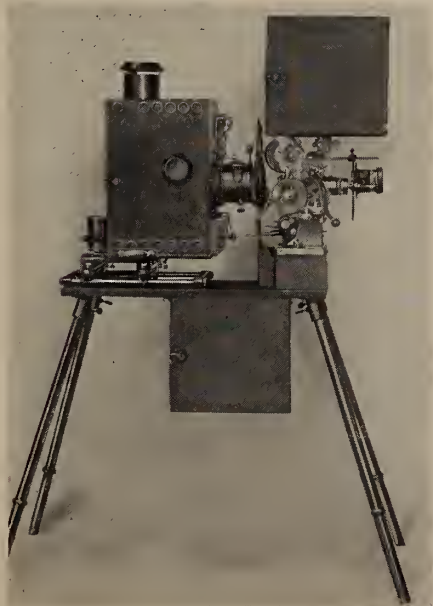

The 6B was the last Powers made (1920) utilizing a roller-pin cross movement. No. 7 Powers was designed but was never manufactured.



Old standby thru the years—the Regular Simplex (1910). Note old framing lever. The light source shown here is the first McAuley reflector lamp.

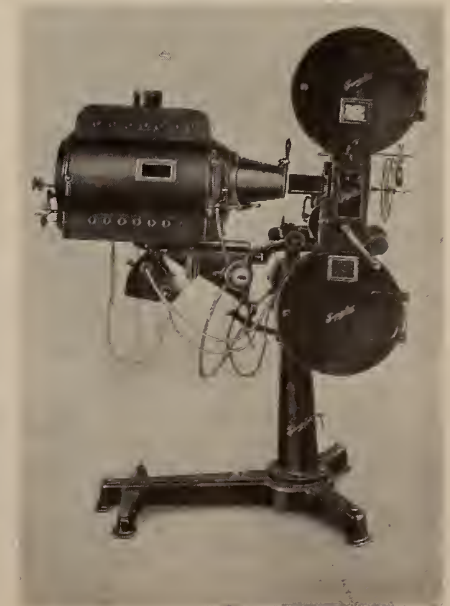

GPL Theater Tv Premiere in Pittsburgh

THE world premiere of General Precision Laboratory's theatre television system more than doubled the normal business of the Fulton theatre in Pittsburgh, Pa., key house of the Shea circuit. The biggest, brightest 16-mm picture ever projected to a motion picture screen was produced at the premiere March 19.

A near-capacity Lenten audience came through snow and sleet and rain to witness the finals of the Golden Gloves boxing tournament which was brought into the theatre by coaxial cable direct from New York's Madison Square Garden. The program was not available over Pittsburgh's lone Tv station.

On-the-Scene Atmosphere

An inescapable on-the-scene atmosphere pervaded the theatre during the televised boxing tournament. Wave after wave of cheering, encouragement and advice was shouted at the screen in the crowd's excitement. When one closely-fought bout was awarded to a member of the New York team which was favored in Pittsburgh, a storm of applause swept through the house. Few members of the audience left the theatre before the last fight of the night, shortly before 11:30.

The GPL Videofilm theatre Tv system receives, photographs, develops and projects telecasts to a regular motion picture screen in one continuous operation of only 60 seconds from Tv action to screen projection. The telecast is photographed on 16-mm film, permitting the system to operate at one-fourth the cost of comparable equipment.

The new GPL system is made up of three compact units: a video recorder;

a rapid film processor, and a special 16-mm arc lamp projector.

At the GPL premiere, a 21 x 16 foot picture on the Fulton's regular screen registered 4000 lumens of light at the screen after a projection throw of 129 feet at a 16-degree angle. The 16-mm picture was projected to the screen with GPL's regular carbon arc lamp, through a 2 1/4" lens.

Equipment Placement in Room

The equipment is designed to fit easily into the average projection room. At the 1,700 seat Fulton, only minor alterations were necessary to install the three Videofilm units in the projection room, which measures 21' x 13' x 9'.

All Pennsylvania state regulations covering projection room equipment were fully observed in locating the 66-inch long video recorder and the 51-inch long developer in a parallel line three feet distant from the room's outside wall. The 16-mm projector was mounted beside the theatre's two regular 35-mm projectors, with a 4-foot span between the center of the already installed 16-mm port and the nearest 35-mm port center.

No adjustments were necessary for the theatre's power supply other than the extension of wires carrying the normal power load. An extension of the theatre's restroom pipelines brought circulating hot and cold water into the projection room. No alteration of any kind was necessary to either stage or screen. Sound output was heard through the theatre's regular sound system. A slight alteration of the projection lens matched the Tv picture precisely to screen size.

Although the Golden Gloves event

came into the theatre by coaxial cable, the Videofilm system can receive directly off the air on a specially built 12-channel tuner.

Theater Men Enthusiastic

John Walsh, manager of the Fulton Theatre, declared normal business at the theatre had "more than doubled" for the premiere, even though the accompanying feature was classed by the Pittsburgh *Post Gazette* the following day as "Hollywood's ten worst pictures rolled into one." Admission prices were not advanced for the showing.

The Shea circuit is now in a position to extend theatre television productions to its two second-run houses in the Pittsburgh area. The GPL equipment allows the theatre owner to retain complete control of programming. The exhibitor may project the film at once or hold and edit it for later showing. The film may be shown repeatedly or circulated among a number of theatres. The Videofilm system can be placed in operation before the theatre is opened to the public or while other attractions are on the screen.

Swiss Eidophore Tv Unit Wins Favor of 20th-Fox

That 20th Century-Fox means business in its tieup with The Swiss Institute of Technology for world-wide rights (excluding Europe) to the Eidophore theatre Tv system was stressed when 20th announced its plan to spend \$500,000 for further development of the apparatus. Introduction of the system will be delayed until it proves its adaptability for projecting color telecasts.

The Swiss have 18 months in which to come up with a system acceptable to 20th, which will then pick up its option and manufacture the units in America. It is understood that the Eidophore unit is comparable in size with a standard 35-mm film projector, and it would be installed in projection rooms and operated from there.

Battle of the Titans?

The recent deal with RCA still is in effect, announced 20th, but its officials praised the Eidophore system as superior in light, definition and tone scales and is comparable, they say, with the light level of motion picture film.

The Eidophore system has a base covered with an oil film on which images are imprinted electronically. The fluid, described as a "cocktail" consisting of mineral oil and two other unspecified substances, sits on a metal mirror. The process is described as "comparable to the relief images on a Technicolor matrix," with hills and dales created on the Eidophore surface. The light, passing through the oil film, is caught by a grid

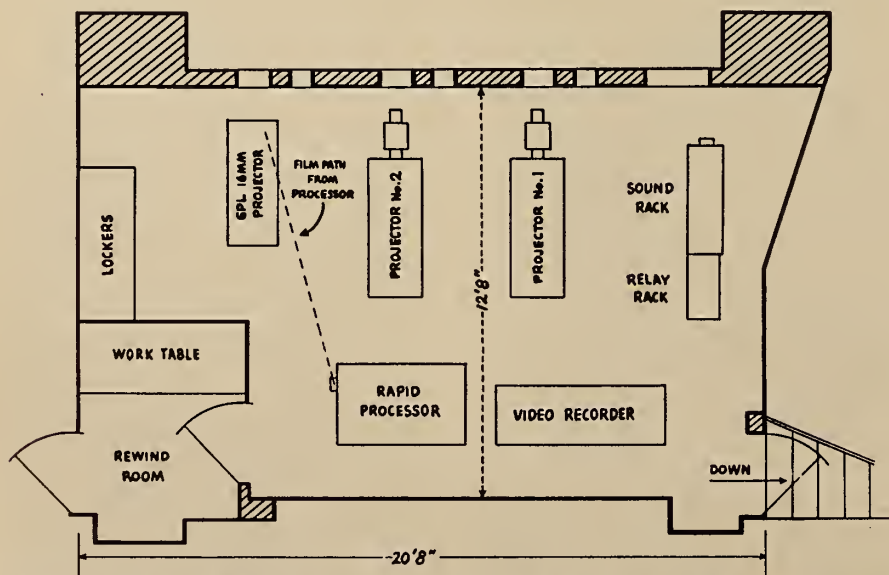

Layout of the Fulton Theater projection room, showing the location of the regular and the additional Tv equipments

of mirrors and focused on the screen with the aid of a carbon arc. The Swiss use 50 frames a second for their demonstrations and are said to be capable of going up to 1000 lines.

New 'Utility' Expands Tv Use

Deeper penetration by Tv into the hinterlands is indicated in a comparatively new development under which communities located up to 130 miles from Tv transmitters, or in terrain considered "dead spots," are being offered service via a new form of "public utility."

System features a community aerial, operated by a business enterprise, erected on a nearby mountain. Signals, too weak for normal reception, are amplified some 500 times and fed through the community by cable. Customers are charged an installation fee ranging up to \$125 for connecting a receiver to the cable, and a monthly service charge of \$3 or \$3.50.

System is being used successfully in Mahanoy City, Pa.; Lansford, Pa.; Astoria, Ore.; Bellingham, Wash., and other places, all 90 to 125 miles from transmitters. Philco Corp. has contracted to sell the system through its own distributors.

BOOK REVIEW

MOVIES FOR TV, by John H. Battison. 5½ x 8¾, 376 pages, profusely illustrated, indexed, cloth. The Macmillan Co., 60 Fifth Ave., N. Y. City, 11. \$4.25.

This is one of the best treatises on the application of motion picture film and its technique that has come to our notice thus far. The ever-growing use of film as basic program material for Tv shows is subjected herein to a comprehensive, practical analysis by an author who is eminently qualified for the task. Mr. Battison is an associate editor of the authoritative electronic journal *Tele-Tech*, which activity he has long supplemented by an intense and unflagging interest in the motion picture art.

This book is no mere essay on the purely artistic aspects of motion pictures; it starts

from scratch at the production stage and covers in a thoroughly practical yet easily understood manner all phases of technique and the equipment utilized in the application thereof to the needs of present-day Tv broadcasting.

Types of projectors and how they operate, together with a list of possible troubles and how best to avoid them; lighting effects and the necessary accessories; types and proper use of lenses, filters; still and moving titles; fades, dissolves and other special effects; program planning and production—all the multifarious activities necessary for high-

quality Tv production are covered in this book in an efficient manner.

Nor are the economic aspects of Tv production neglected, since the author constantly strives to maintain a nice sense of balance as between what *should* and what *can* be done within the limitations of a given budget. It is difficult to imagine any serious worker or patron of the Tv art being without this book. It will pay handsome dividends to its purchasers, and especially to those who are particularly interested in the application of films to the video field.

It's good showmanship to keep the HEART of your theatre running smoothly

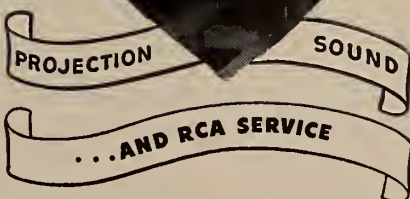
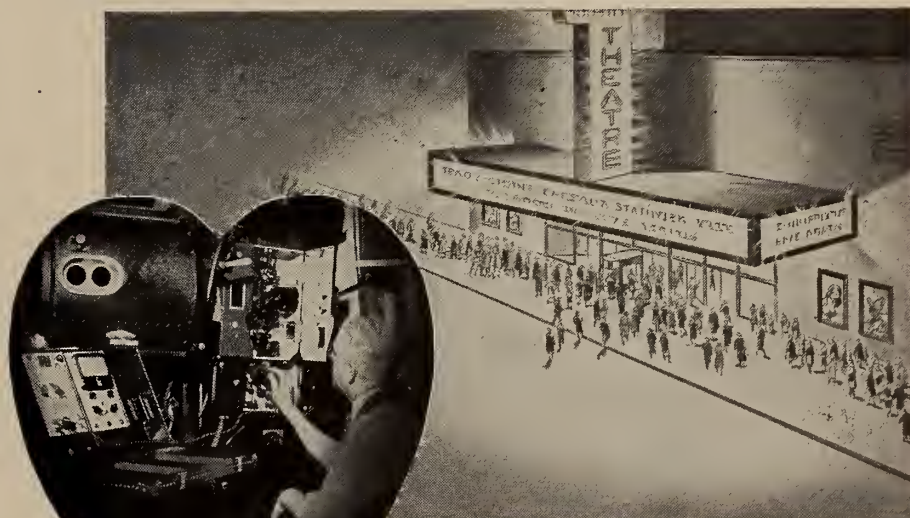

it costs so little to protect so much

The advantages of RCA Service are yours at a cost so low, a few admissions daily pay for it. Write for free folder—"Performance Security."



Every exhibitor, whether he operates a first-run downtown theatre, a neighborhood or small town house, must constantly maintain a smooth-running show to create a steady and reliable following of patrons. It's smart showmanship to present attractions at their very best.

RCA Service, by protecting the projection room equipment—the *heart of the theatre*—makes sure it operates smoothly . . . at top efficiency. RCA Service technicians are skilled in the systematic point-to-point checkup and maintenance of all types of projection and sound equipment regardless of make. RCA Service Plans combine expert technical assistance with comprehensive parts and repair provisions for motion picture and theatre TV equipments.



RCA SERVICE COMPANY, INC.

A RADIO CORPORATION of AMERICA SUBSIDIARY
CAMDEN, NEW JERSEY

Industry Blasts FCC Ruling on Films, Talent for Tv

New woes on the Tv front were piled on the film industry during the month via the pronouncement by the FCC that film companies may be barred from Tv and radio station ownership unless they make films, stories and talent available to existing Tv broadcasters. The general feeling in the industry was that the FCC had over-extended itself by an unprecedented usurpation of authority.

The general attitude of the film indus-

try was perhaps best expressed by Abram F. Myers, board chairman and general counsel of Allied States exhibitor association. Said he:

Typical Exhibitor Reaction

"The report gives the impression that the commission, moved by some undisclosed impulse, hurled a rock at the film companies, but it struck the exhibitors. When a picture is shown on Tv, its

box-office value in the area in which it is shown is destroyed. Certainly Congress never contemplated that the public interest could be served by tearing down an established industry in order to help a rival industry which, once the novelty has worn off, may not retain public favor."

Another industry official made the pointed remark that "I don't see NBC making its stars available to CBS." Indication of trouble ahead for the FCC was a letter to the Commission from Senator Wiley (Rep., Wisc.) in which he charged the FCC with "a gratuitous attack against the motion picture industry." Continuing, the lawmaker demanded an explanation "of just how you (FCC) can justify this, if at all. To my way of thinking, it is very unusual and an extra-legal approach to this question."

Newspaper Condemns Ruling

The N. Y. Times editorialized that the FCC had over-reached itself and was in effect "insisting that Hollywood must come to the aid and succor of its chief competitor. . . . Apparently the FCC is unconcerned whether Hollywood goes broke in serving as the involuntary sugar daddy of television."

It appears doubtful that the FCC can make its order stick, although its past performances in favoring Tv broadcasters leave little room for optimism on the part of the motion picture industry.

Craft Prime Spur to Sales of Strong Trouperette

Projectionists in both America and abroad have contributed power impetus to the sale of the Strong Trouperette spotlight, utilizing "inkie" light, according to word from The Strong Electric Corp., Toledo, Ohio. This new spot finds application in many situations which could not use profitably the Strong Trouper spot which uses a carbon arc at 10 amperes.

The Trouperette was designed especially for small theaters, schools, night clubs, Tv studios and industrial showings, where physical dimensions and economy are prime factors and where the great light output of an arclight spot is unnecessary.

Salient Advantages of Trouperette

Employing a variable focal length objective lens system, a 5½-inch silvered glass reflector, and a standard 115-volt, pre-focused projection-type bulb, the Trouperette is not subject to the substantial light loss occasioned when a spot size is varied solely by iris. It gives sharp edges from a head-spot to a flood, with horizontal masking control up to 45 degrees in each direction. Other

ANSWER TO YOUR TECHNICAL PROBLEMS...



The
Altec
Service
Man

*The Altec
Service Man and
the organization
behind him*



161 Sixth Avenue,
New York 13, N. Y.

PROTECTING THE THEATRE—FIRST PLACE IN ENTERTAINMENT

CLAYTON BALL-BEARING EVEN TENSION TAKE-UPS

For all projectors and sound equipments

All take-ups wind film on 2, 4 and 5 inch hub reels.

Silent Chain Drives

THE CLAYTON REWINDER

For perfect rewinding on 2000-foot reels.

CLAYTON PRODUCTS CO.

31-45 Tibbett Avenue

New York 63, N. Y.

features include a color boomerang accommodating six slides and a height-adjusting mounting stand.

Detailed illustrative and descriptive literature anent Trouperette spot is available to all projectionists for the asking. Address The Strong Electric Corp., 14 City Park Ave., Toledo 2, Ohio.

NEWS PROJECTIONS

INTERSTATE Circuit, Texas, has dropped its plans to install large-screen Tv in Dallas, Houston, Fort Worth and San Antonio. Reason advanced is that Tv will not become serious threat to Interstate until the national coaxial cable enters these towns . . . Anybody lucky enough to get an NPA permit to build a new theater would run into a 20% increase in production costs over 1950; while repair work is reported to be running 30% more . . . Installment buying is responsible in large measure for box-office decline, v.p. J. Robert Rubin told Loew's stockholders. Estimate is that \$20 billion is being paid out by American public today . . . "Too many Westerns" is the complaint of exhibitors. Hoss operas are a dime a dozen, often being dualed on one bill . . . Terrific cost of "live" Tv shows is seen as putting 90% of the programs on film within the next few years.

* * *

While DuMont has cut its factory production from a five- to a four-day basis, ostensibly because of a shortage of materials, a N. Y. City chain store is advertising a premium of a set of dishes said to be worth \$49.50 with each Tv set sale! . . . Another theater Tv installation: the RKO Keith's in Washington, D. C. . . . Tv trailers for network use will be available on 14 forthcoming Paramount releases . . . Survey shows that Tv sets are in the homes of one of every three homes with children under 12 years of age . . . Theater receipts for January last were up 7% over same month of 1950, according to tax figures. Movie houses are credited with paying about 76% of the total theater tax . . . Paramount will reinstate trade showings on a 100% basis with each and every picture in all exchange centers.

'Slow Down' Heart Action in High-Speed Color Shots

A new technique for photographing the heart which makes it possible for the first time to see heart action slowed down 133 times has been developed by the Institute of Medical Research, Los Angeles, Calif., it was disclosed in a paper delivered to the Fall, 1950, SMPTE con-



more
B.A.*

*(BOXOFFICE
APPEAL)

MOVIES
ARE
BETTER
THAN
EVER



with **SUPER SNAPLITE**

f/1.9 projection lenses

• GREATER LIGHT • GREATER CONTRAST • GREATER SHARPNESS

Watch your "B. A." climb when you install Super Snaplite Lenses. Give your patrons the benefit of pictures at their best. You can't beat the Super Snaplite f/1.9 when it comes to putting a clear, sharp picture on your screen.

Super Snaplites give you a true speed of f/1.9 in every focal length up to 7 inches. Ask for Bulletins 207 and 209.

"You Get More Light with Super Snaplite"

KOLLMORGEN

2 Franklin Avenue
Brooklyn 11, New York

Optical



CORPORATION

vention. Said to be a major contribution to the study of rhythm and contraction of the heart through the use of high speed motion pictures, the new technique is expected to be of great value

in the study of the action of drugs and stimulants used in correcting heart diseases.

Shoot 3000 Frames per Second

The process involves use of an ordinary commercial high speed camera in conjunction with an extraordinary amount of light. As many as 20 lamps are used, giving illumination of 1,200,000 foot-candles. In comparison, sunlight on a clear day gives illumination of 11,000-foot candles.

The heart is photographed on 16-mm color film at up to 3000 frames per second, compared with a standard motion picture camera which operates normally at 16 frames per second. In a separate process, impulses of the heart action are recorded on a cathode ray oscilloscope and photographed. The films resulting from these processes are projected simultaneously so that the viewer may see and study the living, pulsating heart.

Movie Theaters in the Argentine

There are 2057 motion movie theaters in Argentina, including small parish and open-air theaters, but excluding regular 16-mm theaters, the U. S. Dept. of commerce reports. There are at least an additional 465 commercial outlets in Argentina using 16-mm equipment. Seating capacity of the 35-mm theaters may total 1,200,000, but all houses do not operate every day or throughout the year. More than 1500 theaters, with a seating capacity of 650,000, operate regularly every week. Theaters using 16-mm films vary in seating capacity from 100 to 300.

Projection and sound equipment in the better theaters in the Buenos Aires area is

comparatively new and in good condition. Almost every small theater in the interior has old French or German projectors which have been adapted to sound with equipment manufactured in Argentina by Philips (Dutch).

Sound, Visual Projection Needs

The need for new projection and sound equipment is extensive, but effective purchasing capacity is limited. Should the Argentine Government authorize procurement in the U. S. A., only the largest theaters could meet the high prices at the increasingly unfavorable rates of exchange.

Carbons are a very serious problem to the Argentine exhibitor, as none are made domestically, and those imported from Europe are about twice the price of German carbons. All but the most delicate pieces of equipment are manufactured in Argentina. Two machine shops produce a relatively satisfactory 35-mm projector, equipped with Philips sound equipment and sold under the same name. Production ranges from 50 to 70 machines a year, but is not sufficient to meet the demand.

Famous Players Canadian '50 Earnings

Consolidated net earnings of \$3,529,514, or \$2.03 a share, are shown by Famous Players Canadian Corp. for 1950, compared with \$3,071,910, or \$1.77 a share, in 1949.

Operating profits, after providing \$1,047,575 for depreciation, amount to \$4,876,359, investment income to \$680,194.

Top Billing . . . Emotionally; Community Chest Drive

There is a small, lonely grave in an old, forgotten cemetery in Graniteville, S. C., marked only "The Little Boy, October 1855." It haunted John F. Watlington of Charlotteville, N. C., who headed the Community Chest drive this year. His inquiries revealed that "The Little Boy," traveling alone on a train through Graniteville, became ill and was taken off the train. A kindly family gave him refuge, but within a few days he died. No one had learned his name or where he came from or where he was going—but sympathetic townsfolk put up the marker.

"It just couldn't happen today," Mr. Watlington said when he uncovered the story. "Travelers Aid, a Red Feather service, would be on hand to help the little boy; to see that he had prompt medical and nursing care, perhaps to ease some family trouble that may have lain behind the little boy's tragic journey."

EFFICIENT • DEPENDABLE

RECTIFIERS

for Every Type Projection Lamp



**2-Tube
4-Tube
6-Tube
Single and
Three Phase
Models for**

- Rotating Feed Angular Trim High Intensity
- Copper Coated Coaxial High Intensity

- 1 K.W. High Intensity
- Low Intensity

Smooth Output Current • Long Life
Low Operating Temperature
Flexibility in Control

Write today for literature or free demonstration.

**THE STRONG
ELECTRIC CORP.**

**31 CITY PARK AVENUE
TOLEDO 2, OHIO**

PROJECTION LAMPS • RECTIFIERS
SPOTLIGHTS • REFLECTORS

ONLY

Century PROJECTORS

HAVE EVERYTHING

CENTURY'S high-efficiency projector with the NEW 4-inch diam. lens provides pictures of increased brightness and appeal—for even the largest drive-in screens.

CENTURY'S water-cooled aperture gives as much light with a 90 ampere arc as other projectors using a 180 ampere arc and heat filters!—Reduce power cost—Get sharper pictures—Save film.

CENTURY'S sealed, oil-less bearings and glass-hard gears reduce maintenance costs. No oil sprays or baths to mess up film or projection room.

You can SEE and HEAR the difference!

CENTURY PROJECTION AND SOUND SYSTEMS
See your dealer or write for information

CENTURY PROJECTOR CORPORATION

New York, N. Y.



BUY U. S. SAVINGS BONDS

Your Very Best Buy

BUY U. S. SAVINGS BONDS

Speed of Light Re-Evaluated By a New Method Developed by British Scientists

AN experiment recently completed at the National Physical Laboratory* has shown inaccuracy in the normally accepted figure for the speed of light. The difference is not great—only 11 miles per second. It is, however, far from being a matter solely of academic interest, for the speed of light is used for many of the fundamental calculations. The more accurate figure is of immediate practical value in radio and radar.

The speed of light is, in Einstein's theory of relativity, the highest speed at which anything can travel. It is therefore an important physical constant, and its measurement has provided a problem for scientists for many years. Romer first obtained a value of 192,000 miles per second from astronomical observations in 1676.

The first direct experiment measurement was made by Fizeau in 1849. A beam of light was focused on the rim of a toothed wheel, and, after passing through a tooth, it traveled a distance of 4 miles and was reflected back to the wheel. If on its return the light fell upon one of the teeth, it could no longer be seen from behind the wheel. The wheel was therefore speeded up until the light disappeared, and the time of travel was calculated from the rapidity with which the wheel was turning.

Michelson's Famous Experiment

In more recent times, in 1935, Michelson in the U. S. A. made a famous experiment in which a beam of light traveled in a metal tube a mile long, the tube could be evacuated in order to remove the small effect of the atmosphere on the speed. The final value he obtained was 186,271 miles per second. This figure was confirmed in other experiments and has been accepted ever since.

When Dr. L. Essen of the NPL* announced in 1947 that the figure should be 186,282 miles per second, the result was received with some scepticism. He has now confirmed the result, using more refined apparatus, and results recently obtained in Sweden and in the U.S.A. agree with this value to within one kilometer a second. Dr. Essen was concerned with the propagation of radio waves. Radio waves differ from light waves only in their wavelength, and

* London, England.

it is generally assumed that they travel at the same speed.

During the war, Dr. Essen was frequently asked what was the correct value of the speed of light. He began to suspect that, although they had been carried out on an impressive scale, the experiments were perhaps not as accurate as was generally believed. He thought that the NPL might do better by using radio waves, and he started work on the problem soon after the war.

The method is similar in principle to Michelson's, but, whereas he used a tube a mile long, Essen's tube is only 7 inches long. A radio wave was sent down this metal tube and reflected backwards and forwards between the two ends. When the time of travel between the ends equals the time interval between successive waves, they build up to produce an electrical resonance which can be detected with very high precision.

New Procedure Evolves

In this experiment, the time of travel is about one ten-thousand-millionth of a second (1/10,000,000,000) or, in other words, the waves follow one another at a frequency of 10 thousand million per second, and it was necessary to measure this frequency with an accuracy better than one part in a million. This is just the kind of problem that Essen was working on during the war and the equipment that was built then was ideally suited to the velocity experiment. The construction of the tube called for very skilled workmanship and its dimensions had to be accurate to one hundred-thousandth of an inch.

The speed of light was not wanted ac-

curately for any practical purpose until the advent of radar in World War II. In radar the distance to an object is calculated from the time taken by a pulse of radio waves

WORN PROJECTOR PARTS

make Poor Pictures

That's bad business! They make the picture jerky, cause irritation and eye strain—may cause patrons to pass up these "shaating galleries" for other theatres where equipment is kept in smooth operating condition. Cost of replacing worn projector parts is so trivial—the benefits so great!

Replace with genuine



Precision Made Projector Parts

LAVEZZI MACHINE WORKS

4635 W. Lake St.
Chicago 44, Ill.



This is the **CARBON SAVER**
Everyone Is Talking About!

Start now to conserve your supply of carbons which have the heavier copper coating. Now, more than ever, it is important that you make use of every inch of every carbon, and here's the carbon saver that really does the job.

THE CRON-O-MATIC FULLY AUTOMATIC CARBON SAVER

uses up carbon stubs of all lengths with no preparation required. Simply insert in the holder and forget it. It in no way interferes with the regular operation of the lamp. **CUTS CARBON COSTS 25%.**

Adaptable to Ashcraft "D", Brenkert-Enarc, Peerless Magnarc and Strong Mogul lamps.

Only \$52.50. Quickly pays for itself . . . then goes on to make money for you.

If your theatre equipment dealer cannot supply you, order direct.

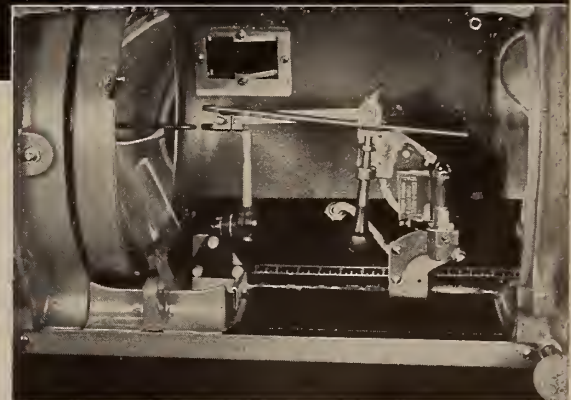

PAYNE PRODUCTS COMPANY

Cron-O-Matic Division

2454 W. Stadium Blvd. Ann Arbor, Michigan
() Please send free literature on Cron-O-Matic Carbon Saver.
() Send name of nearest dealer.
() Please ship Cron-O-Matic Carbon Saver,
() C.O.D. including postage, () Remittance herewith.

NAME
THEATRE
STREET
CITY & STATE
Dealer Inquiries Invited

THE OPERATORS' FAVORITE!

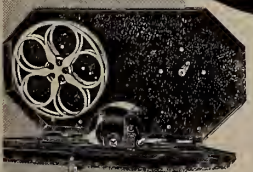

GoldE's Automatic Enclosed Rewind Always Works! Silent, safe, U.L. approved! Eliminates fire hazard. Positive friction . . . can't clinch film. Tilt-back case . . . reels can't fly off. Microswitch safety cut-off . . . when door opens or film breaks, motor stops!

AT BETTER THEATRE SUPPLY DEALERS
GOLDE MANUFACTURING COMPANY
1222-P. WEST MADISON STREET • CHICAGO 7, ILLINOIS

to travel there and back, the speed of the waves being the same as that of light. The new figure will therefore enable radar to be used more accurately. This will be particularly valuable for aerial survey work where the shape of the ground is plotted by means of radar.

The speed of light is also used in calculating a great number of physical constants. The most significant changes will probably be in astronomy, in atomic research, and in the field of radio.

From "Electronic Engineering" (London)

PROJECTIONISTS ALREADY HAVE TROUBLE ENOUGH

When a projectionist presses the button to open the curtain and get the show underway, he expects the curtain to open—and so does the boss.

Failure of the curtain control equipment at that critical point sends blood pressure zooming, clips many a useful year from the projectionist's life. It also sends spectators' blood pressure skyward, clips many a dollar from the box office take.

Wise projectionists avoid all these difficulties by recommending to the boss that he install Vallen curtain controls, tracks and special operating devices. They've been answering projectionists' demands "on the button" for 35 years, because they're precision-engineered to do their job.

Put a Vallen catalog in the front office now. Just drop a note, asking for a new catalog, to VALLEN, INC., Akron 4, Ohio.

TV WON'T RUIN EVERYTHING

(Continued from page 10)

rusty velvet. Yet, as far back as early Rome, the satirist Juvenal said, "If you want to get to the Emperor, don't lick the boots of a knight, curry favor with an actor."

In Shakespeare's time actors were classed with vagabonds and fined rather than licensed for playing. Yet some of them were the pets of royalty, and Queen Elizabeth asked Will Shakespeare to write a sequel to his *Henry IV* and star Falstaff in it. Which he did.

State of the Theater Today

Today, the theater has innumerable enemies. Yet never before in history have certain dramatists made so much money from such unprecedentedly long runs.

There has probably never been a book or play to rival the sales and performances of *Uncle Tom's Cabin*, but the poor little preacher's wife who wrote it was paid only a small sum for the serial rights, never got a cent out of the numberless editions of the book published in America, or in foreign countries, or from the play which had, I think, four companies playing simultaneously in London, two in Paris and others in other European capitals.

Nowadays, thanks to modern copyright laws and treaties, and the Dramatists', Screen Writers', Radio Writers' and other Guilds, the author is so protected that George Bernard Shaw became a million-

aire, and other writers have amassed even more money.

The theater is dead, but just try to get a ticket to any of several theaters in New York! Radio is dead, yet several radio comedians are being paid fabulous sums. As for books, the ex-clergyman, Lloyd Douglas, wrote a religious novel, *The Robe*, which outsold *Forever Amber*, and his *The Big Fisherman* about the Apostle Peter is outselling all exotic or obscene sensationalisms.

Effect of New Art Forms

The point I want to make is this: every new form of art seems at first to destroy the older forms. But, eventually, it increases or enriches our culture and increases the number of participants in it.

From the beginning of mankind and womankind, he or she who could tell a story or act out a character or speak a thrilling piece or sing a catchy song has found an audience—in primeval cave or Metropolitan Opera House. The actor who leapt on an altar and exchanged dialogue with another actor—and thus began the glories of Greek drama—was doing just what an actor does on the modern stage or before a camera, microphone or kinescope.

Entertainers have fed a primeval, in-

General Precision Earnings for 1950

General Precision Equipment Corp., parent company of several large motion picture equipment companies, reported a net operating profit after taxes for 1950 of \$871,899, equal to \$1.45 a share. Earnings the year previous were \$456,485, or 76 cents a share. Total sales in 1950 were \$27,072,360, an increase of about \$300,000 over 1949.

NEVER HAS

Economy
BEEN SO
ESSENTIAL AS NOW!

THERE IS A LORRAINE CARBON TAILORED FOR YOUR SPECIFIC PROJECTION REQUIREMENT

Send necessary projection equipment data to guide us in recommending the Lorraine Carbons that will do your theatre or drive-in projection job better and More Economically.

SLOW BURNING

SAVINGS IN POWER CONSUMPTION

SAVINGS IN MAINTENANCE

ECONOMIZE

WITH *Lorraine Carbons*

Lorraine CARBONS, INC., BOONTON, N. J.

**29
BRANCHES**

BORDER TO BORDER
COAST TO COAST

*Ready to
Serve you!*

NATIONAL
THEATRE SUPPLY
Division of National • Simplex • Bludworth, Inc.

YOU CAN "RELY" ON NATIONAL

satiating hunger, for perhaps a million years, and will be doing so a million years from now. If I'm wrong, tell me so a million years from now.

A similar thing is true in industry. Every labor-saving machine throws certain workers out of employment; but if it succeeds, it vastly increases the numbers employed.

Acceptance of the New

Back in 1779 there was a half-witted fellow named Ned Lud, who earned a pittance by knitting stockings. Along came a villain who invented a knitting machine. So Ned Lud was inspired to attack the machine. In 1811 infuriated working men destroyed all the machines of every kind that they could get at. This movement was given the name of the idiot who inspired it and the machine-haters were called "Luddites." We see their spirit at work everytime a new device is announced.

People ought to accept new inventions and the new customs to which they give rise as they accept floods and earth-

quakes. It does no good to curse them or berate them. It is better to revise one's habits and adjust one's life to the new conditions.

In Washington's time the expectancy of life was actually no more than 19 years. Today it is 68 years! In Washington's time the biggest city was Philadelphia with 17,000 people. Today we have over 150,000,000 inhabitants, and they are living longer than people used to. As they get older they need more, not less, of such diversions and time-fillers as the theater, the motion picture, radio, television, churches, lectures, concerts.

Yesteryear's 'Drowning Animals'

In the old days people lived out their lives without leaving their villages or cities. They knew little or nothing of outer life, unless a war brought it home. They were like drowning animals. In Washington's time, New York had less than 20,000 inhabitants with only spasmodic performances at the few playhouses. Washington rarely missed a play, and he was such a joyous spectator that often the audience would hush and look up at the box and say "listen to the President's laugh!" What a godsend the theater was to that tormented man! What a soul saver it has been to other tormented men and women! Radio and television bring the theater and the motion picture into our homes.

The children of today know far more about vast numbers of things that the most learned men of a century ago were entirely ignorant of. The motion picture, radio and television have an educational power that is infinite, however little recognized or praised. And they create a public and a patronage for books, plays, and all the arts.

More, Not Less, Diversion

There is room for *all* the arts and *all* the artists and *all* their managers and patrons. It is inevitable and not altogether regrettable that there should be fierce competition among them, and an unending search for new inventions.

Lucullus, a Roman general enriched

by conquests, gave feasts that were famous for the luxury and variety of the countless things to eat and drink. But they were even more famous for the musicians, artists, philosophers, poets and dancers who entertained the guests.

Today the poorest of our citizens is offered a feast for eyes, ears, heart and soul such as would make Lucullus feel like Bill Nye confronted with the choice of tea or eggs?

Why are we not rejoicing instead of complaining?



LOOK TO WENZEL

for the Finest in Projector Equipment



Closed Sound Head

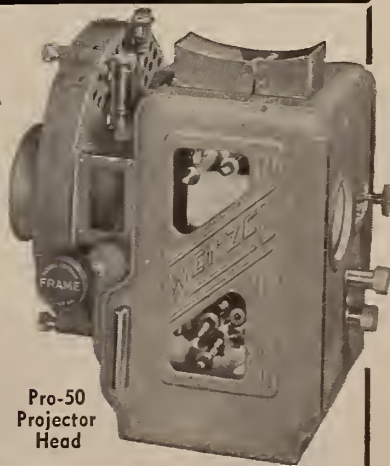

Pro-50 Projector Head

WENZEL PROJECTOR CO.

2505-19 S. State St.

Chicago 16, Ill.

HONEYCOMB-CONDENSER

(Continued from page 9)

particular type of crater brilliancy-distribution.¹ Second, the "apospherical" mirror method suggested by the writer.² Third, the Zeiss honeycomb-condenser arrangement described in this issue.

The honeycomb-condenser system is worthy of special attention for several reasons. At first thought the advantages claimed for it seem almost too good to be true. But even if Dr. Schultze's optimistic report is only half true, it still can be maintained that the Zeiss Ikosol arc-lamp seems to me to be the most important advance made in projection lighting since V-E day, not even excepting the ingenious automatic arc-control devices introduced since then. The Ikosol renders such devices unnecessary.

The firm of Carl Zeiss is world-renowned for technical accuracy. The astonishing independence of the performance of the Ikosol lamp from fluctuations in the position of the positive crater and the burning of the trim has been confirmed by F. Hodam of the DEFA-Forschungsabteilung, Berlin.

Here, in a nutshell, is the theory of the honeycomb-condenser system. The "spot"—the image of the positive crater—is imaged not on the picture-aperture but on a heat-resistant glass plate containing 150 plano-convex lenses of rectangular shape. Each of these lenses images the mirror upon the corresponding lens of the plate containing 150 hexagonal lenses. And the hexagonal lenses, in turn, image the rectangular lenses on the aperture. The result is 150 superimposed rectangular "spots" on the rectangular picture-aperture.

Summary of Advantages

The obvious advantages of the Ikosol lamp are:

1. Nearly perfect uniformity of picture illumination and of the color of the projection light are insured by the *superposition* on the aperture of 150 individual rectangular images which intercept the *entire light-beam* thrown forward by the mirror.

2. Remarkable freedom from the ill effects of varying crater position is insured by the fact that the *mirror*, not the *positive crater*, is imaged by the rectangular lenses on the hexagonal lenses of the lens-plate nearest the projector mechanism.

3. The loss of light caused by four glass-to-air surfaces is more than compensated for by the fact that the spot is rectangular, not circular. This not only prevents the waste of light inherent in a circular spot but also keeps the mechanism cool.

4. Unprecedented ease of operation and servicing.

5. Simplification of lamp design with resulting low cost to the exhibitor.

The possibility of using currents under 40 amps for H-I lighting does not impress this writer as a noteworthy advantage of the Ikosol. There are very few theaters having screens so small that arc currents lower than the minimum of 40 amps could be used to advantage.

Summary of the Disadvantages

The disadvantages are:

1. The distance from the mirror to the honeycomb-condenser plates, the distance separating the two plates, and the distance from the hexagonal-lens plate to the picture aperture are all *extremely critical*. There is absolutely no doubt about this. The lamp must therefore be set up on the projector pedestal with great accuracy, and the distance from the projection head kept within a 2-mm tolerance.

2. Danger of disturbing factory adjustment of the honeycomb-condenser assembly when taking it apart for cleaning. The two plates form a coordinated unit. Azimuth, as well as working distances, must be maintained with the greatest precision.

3. A slightly greater angle of "light-spread" on the screen side of the aperture, requiring the use of slightly larger projection lenses in order to match the efficiency of ordinary mirror lamps, and to avoid lens "vignetting" effects which might partially cancel the uniform aperture-illumination characteristics of the Ikosol lamp.

4. A temptation to ignore entirely the

manner in which the carbons burn, thus increasing the likelihood of losing the high-intensity effect. Carelessness in this regard would result in flickering of the arc, greatly diminished brilliance, and a discoloration of the entire picture noticeable on changeovers.

Some of these disadvantages, the second and fourth in particular, can be overcome by competent engineering of the lamp. The Zeiss Ikosol may actually be free from some of these drawbacks. It is too early to be certain of this point, as the lamp was introduced commercially only about a year ago and is unknown outside of the U.S.S.R. and the Russian-occupied zone of Germany.

Film Houses in United Kingdom

A total of 4,583 motion picture theaters are reported to be in operation in the United Kingdom, with an estimated total seating capacity of 4,160,000. Another 109 theaters have recently closed or changed over to stage shows.

Statistics for the first quarter of 1950 reveal that an average of 28,500,000 persons attend motion picture theaters each week. Admission prices range from 3 pence in a few theaters to as high as 11 shillings for the best seats in certain London West-End theaters. In the average community theater, seats are usually from 1 shilling to three shillings, 7 pence. The usual prices for second-run theaters are from 9 pence to 2 shillings, 9 pence. (Pound sterling equals U. S. \$2.80; there are 20 shillings in a pound, 12 pence in a shilling). The gross income of motion picture theaters during 1950 is estimated to have been £112,000,000.

How Many?

Was this copy dog-eared when it came to you? How many men read it ahead of you?

You would receive a clean, fresh copy if you had a personal subscription—and you wouldn't have to wait—you would be first to read it.

Use coupon below.

INTERNATIONAL PROJECTIONIST.

19 West 44 St., New York 18, N. Y.

Enter my subscription for 1 year—12 issues—\$2.50
 2 years—24 issues—\$4.00

Foreign and Canada: Add 50c per year.

Name

Address

City State

**Guard Your Family
STRIKE BACK!**



GIVE to Conquer Cancer

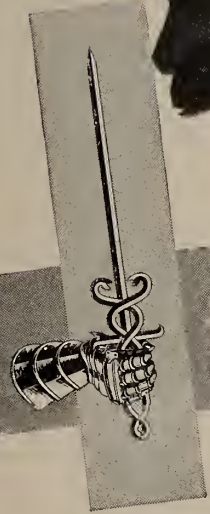

IF SOMEONE IN YOUR FAMILY HAD CANCER, you would do anything . . . everything that would help. And today there is so much that you can do to help. Tens of thousands of families just like yours meet cancer every year and triumph over it. But we are still losing too many men and women we love.

Doctors can now cure half of those who develop cancer if the disease is diagnosed in its early stages. Yet in 1950 some 210,000 families lost a father, a mother or a child to cancer. Many of them—probably 70,000—could have been cured.

To save more lives, we all must help. Your gift to the Cancer Crusade will help guard your family by providing more research, more

life-saving education, more training for scientists and physicians, more equipment, more services for those already stricken with the disease.

Cancer is man's worst enemy. Striking back at cancer costs money. Any contribution is welcome but, the fight against this major threat deserves major support: dollars—tens—twenties—hundreds of dollars. Will you help?

A M E R I C A N C A N C E R S O C I E T Y

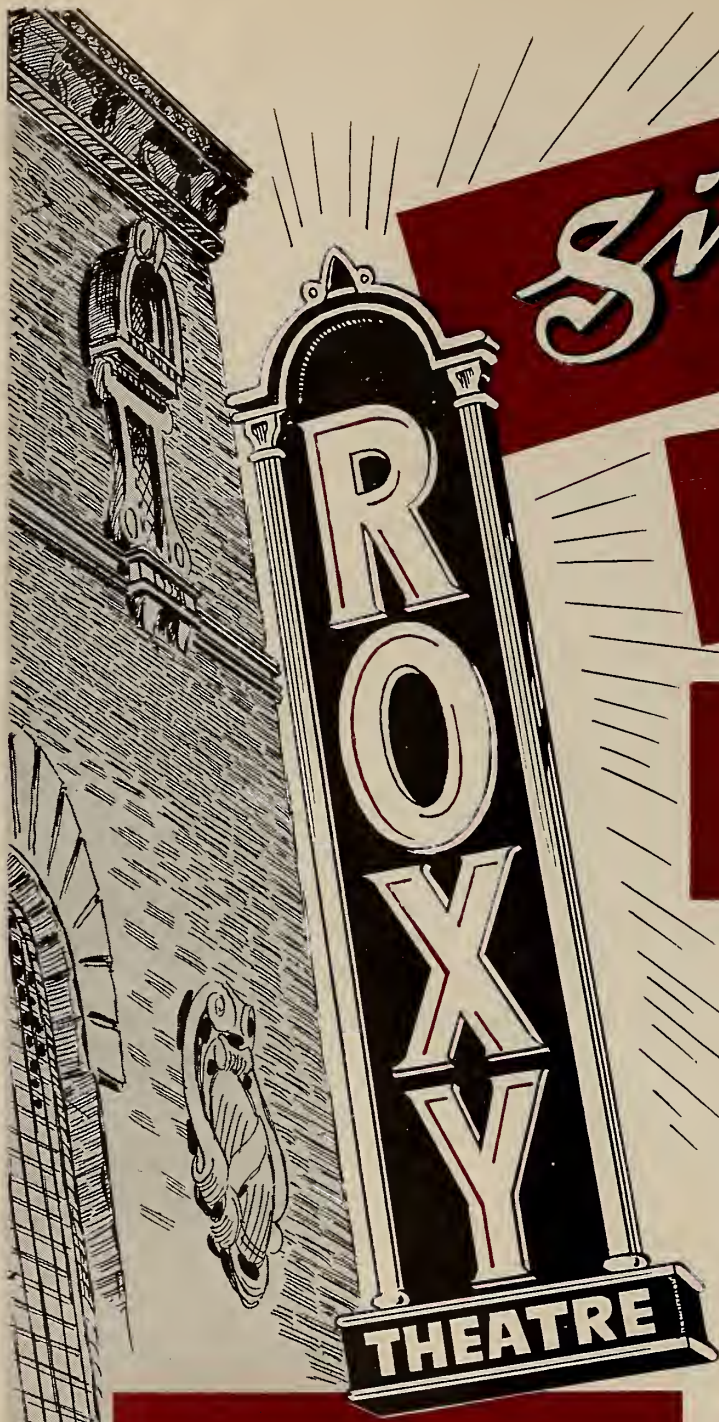

Simplex

CHOSEN

AGAIN!

The ROXY, one of the world's leading theatres, must assure the millions who visit it each year of the finest in motion picture entertainment. That is why the ROXY has chosen to install SIMPLEX X-L, the finest in motion picture projectors. For the owners of this great theatre know they can rely on the SIMPLEX X-L for a standout performance every time.

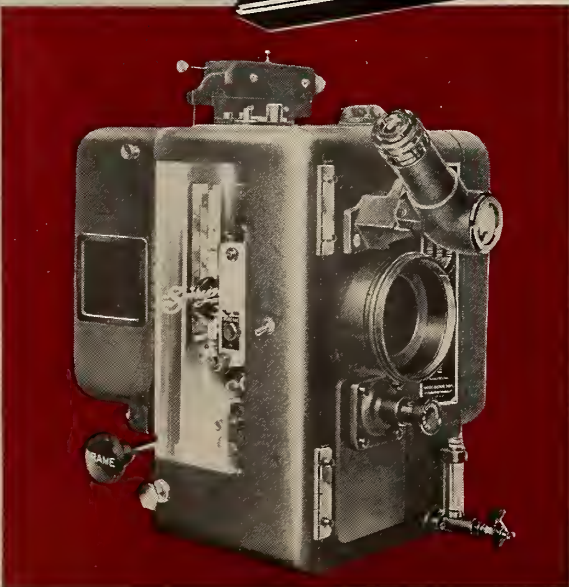

Simplex
TRADE MARK REG'D

X·L

PROJECTOR

MOVIES ARE YOUR BEST ENTERTAINMENT—SEE ONE TONIGHT.

MANUFACTURED BY INTERNATIONAL PROJECTOR CORPORATION • DISTRIBUTED BY NATIONAL THEATRE SUPPLY

30 1870

PROJECTIONIST

INTERNATIONAL



JUN 12 1951

MAY

1951

VOLUME 26



NUMBER 5

30c A COPY



\$2.50 A YEAR

ALONGSIDE THESE LAMPS STAND THE WORLD'S FINEST PROJECTIONISTS

Peerless

1-KW TO 70 AMPS

MAGNARC
TRADE MARK REG.

"HY-AX" ARC MAGNET

"HY-LUMEN" REFLECTOR

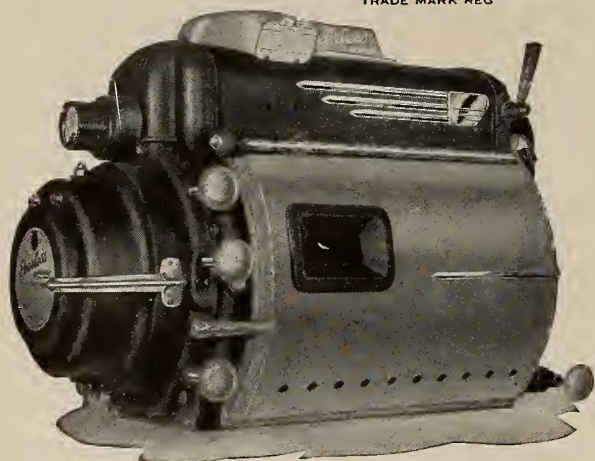

More light at 40 to 70 amperes than ever thought possible. . . . Equals and excels any reflector lamp to 85 amperes, whether they be unapproved water-cooled or resurrected "Hi-Lows". . . . Highest ratio of honest screen lumens per arc watt. . . . At 70 amperes, using an accurated Glass Hy-Lumen Reflector*, with a projector having an efficient revolving shutter, it develops the maximum screen brilliance that can be used without a heat filter at no risk of film damage. . . . Operating costs under these conditions are far below that of 85-ampere lamps.

Magnarc Lamps assure 80% side-to-center (SMPE Standard) screen light distribution, not a deceptive 60% or "Hot Center". . . . They are all Und. Lab., Inc. listed. . . . They are not insurance hazards. . . . They are and have been for years "The First Choice" of large and small theatres, drive-ins, and the motion picture industry.

* Similar results are not guaranteed if all-metal reflectors are used.

"FIRST WITH THE FINEST"

130-180 AMPERES



Peerless
**HY-
C** CANDESCENT
TRADE MARK REG.

NEW MAGNETIC STABILIZER

This modern lamp produces all the light there is. . . . It is the standard equipment of the nation's largest and finest theatres. . . . Used by 90% of the largest Drive-In Theatres.

It is the "Omega" for maximum screen brilliance. . . . Nothing can even approach it in white light volume when used with projectors that have efficient revolving shutters.

Assures satisfying projection for Drive-Ins regardless of the size of the picture, length of throw, and under all weather conditions. . . . They are Und. Lab., Inc. listed and, therefore, not insurance hazards. . . . Heat filter assures no risk of film-heat damage at maximum arc amperage and maximum screen lumens.

"WHY EXPERIMENT?"



J. E. McAULEY MFG. CO.

552-554 WEST ADAMS STREET
CHICAGO 6, ILLINOIS

INTERNATIONAL PROJECTIONIST

With Which Is Combined PROJECTION ENGINEERING



HENRY B. SELLWOOD, *Editor*

Volume 26

MAY 1951

Number 5

Index and Monthly Chat.....	3	Theater Television <i>via</i> the RCA PT-100 Equipment, VI.....	18
The Differential Carbon-Feed System	5	RCA SERVICE COMPANY	
ARTHUR J. HATCH		Roundup of Operation, Mainte- nance Data	19
Report on the 69th SMPTE Con- vention	10	H-I Carbon-Arc Spotlights En- joying a New Vogue.....	21
The Magic of Color.....	13	IA Elections	21
ROBERT A. MITCHELL		Telecasts	22
Theater Equipment and NPA Regulations	15	News Projections	23
In the Spotlight.....	16	Technical Hints	
HARRY SHERMAN		Miscellaneous Items	

Published Monthly by

INTERNATIONAL PROJECTIONIST PUBLISHING CO., INC.

19 West 44 Street, New York 18, N. Y.

Telephone: MUrray Hill 2-2948

R. A. ENTRACHT, Publisher

SUBSCRIPTION REPRESENTATIVES

AUSTRALIA: McGills, 183 Elizabeth St., Melbourne

NEW ZEALAND: Te Aro Book Depot, Ltd., 64 Courtenay Place, Wellington

ENGLAND and DOMINIONS: Wm. Dawson & Sons, Ltd., Macklin St., London, W. C. 2

YEARLY SUBSCRIPTION: United States and possessions, \$2.50 (two years, \$4); Canada and foreign countries, \$3; single copies, 30 cents. Changes of address should be submitted two weeks in advance of publication date to insure receipt of current issue. Entered as second class matter February 8, 1932, at the Post Office at New York, N. Y., under the act of March 3, 1879. Entire contents copyrighted 1951 by International Projectionist Publishing Co., Inc. INTERNATIONAL PROJECTIONIST is not responsible for personal opinions appearing in signed articles in its columns.



420

MONTHLY CHAT

IT REMAINED for Peter Mole, president of the SMPTE, to point up one of the chief reasons for the present sluggish state of the motion picture theater box-office and at the same time deliver a stinging rebuke to the "leaders" of the film industry. Speaking at the recent convention of the Society, Mr. Mole laid it right on the line, as follows:

"Technical contributions already at hand are so far ahead of the industry's willingness to accept them that the lack of interest may have the effect of applying a brake on future technical growth." The SMPTE prexy went on to enumerate these advances in the art: stereoscopy, multiple sound tracks, more and better color, wide-angle pictures, and theater Tv.

The foregoing is practically a verbatim transcript of a theme which has been played in this column on several occasions. As far back as 1948 this corner stated flatly that the aforementioned advances were ready and awaiting only their adoption by the industry. Again, in January, 1949, we opined:

"Three-dimensional pictures, stereophonic sound, and greatly improved color processes are but three of the advances long promised by the film industry. But it begins to look as though the Big Brass have become very coy about putting money into technological developments on behalf of an industry which, while the source of their personal power and opulence, might possibly be in for a bit of rough going . . . these developments would be duck soup for that gang of technicians who have brought Tv to its comparatively high estate."

All of the aforementioned Big Brass are eager beavers when it comes to attending swank public functions, or receiving plaques for "accomplishment," or orating before some unsuspecting Chamber of Commerce or a group of newspaper editors (the latter resulting in fulsome newspaper space). But when it comes to taking positive action to aid the industry which harbored them for so many years (and we mean "harbored") their mental nakedness is appallingly revealed.

Lush cash surpluses abound in the film industry, both production and exhibition, but these are scrupulously maintained as a sort of perpetual reminder of the management "genius" of their guardians. We call it not a reminder but a monument, because that is precisely the function it will serve if positive action looking toward the aid of the theater field is not taken soon.

If industry management continues to chant "How much will it cost?" the time is not far off when they will be forced to turn their attention from the comparatively easy racket of mulcting theaters *via* exorbitant film rentals and go out into the market place and compete with some real brains in the advertising and Tv fields.

The
No. 1

LAMP

for projecting the most
light to any screen—
regardless of how large
—and the No. 1 lamp
for saving you money.

At 90 amperes it pro-
jects 21,000 lumens at
far less cost than any
other types of big lamps.

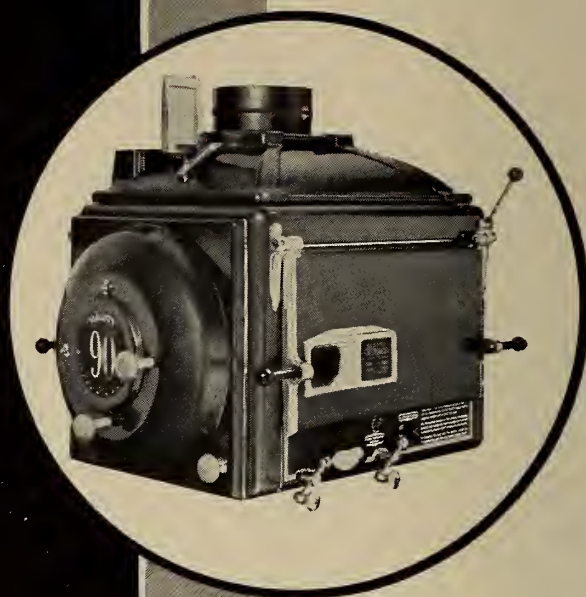

THE STRONG

MIGHTY "90"

75 TO 130 AMPERE REFLECTOR ARC LAMP

Write today for free literature

The Strong Electric Corporation

31 City Park Avenue • Toledo 2, Ohio



The Differential Carbon-Feed System[†]

By ARTHUR J. HATCH
Strong Electric Corporation

Various fragmentary portions of this paper have been published, but appended is the official transcript as released by the SMPTE. The differential carbon-feed system applies a new principle in meeting the exacting requirements of arclamp automatic carbon feed and positioning.

THE allowable tolerance in carbon crater position has been reduced by the use of the higher-speed lamphouse optics, while the difficulty of maintaining the arc crater at a given position has been increased by the high brightness carbons with their higher burning rates. These higher burning rates are unfortunately accompanied by greater fluctuations of burning rate with small current changes.

These factors have made it desirable to incorporate automatic means in the carbon feed to maintain the position of the positive crater accurately to the lamphouse optical system.

Basic Feed Requirements

This problem of providing automatic positioning to the positive crater of high-intensity projection arc lamps has necessitated a review of the requirements for carbon feeds, as such a positioning control cannot be conveniently or effectively inserted into the type of feed mechanisms in general use at present. Accordingly, to utilize an automatic positioning device it has been necessary to develop a new carbon-feed system.

We find that the principal end results

desired are uniform and constant intensity of screen illumination with constant color temperature. These results should be obtained through a carbon-feed system that has simple control adjustments and which is capable of self-compensation for changes in the variables, without attention from the projectionist.

The major electrical controlling factor necessary to obtain constant screen illumination, with a given carbon trim, is constant arc amperage. With proper arc circuit ballast, the arc amperage will assume a value such that the sum of the positive and negative carbon-burning rates, at that arc current, equals the sum of the positive and negative feed rates. Then, assuming for the moment that the carbon-burning rates are constant for a given current, it will be readily seen that a constant total feed rate will provide most even illumination.

Therefore, a very simple carbon-feed mechanism could be constructed which would advance the relative positions of the carbon holders one to the other at the constant rate necessary to maintain the desired current.

The negative carbon could stand still and the positive carbon could be advanced at a rate equal to the total burn-

ing rate of both carbons; or the positive could stand still and the negative could advance at the total rate. Any number of positive and negative feed ratios could be used as long as the combined feed added to the figure desired for total feed.

Division of Total Feed

This simple feed, however, would not take into account the fact that to utilize the illumination from the carbon arc for projection, the positive crater must be kept at the exact entrance focal position of the lamphouse optical system. It is, necessary therefore, to make provision to divide the total feed into positive and negative feeds, in a proportion exactly equal to the positive and negative burning rates at the particular current desired, in order to maintain the position of the positive crater to the optical system.

This division of the total feed into its components needs to be flexible, unless the lamp is to be burned at a single current, as the ratio between positive and negative burning rates varies considerably through the current range of the carbons.

An Ideal Feed System

The operation of this ratio-fixing control should not affect the sum total feed rate of the positive and negative carbons. For this reason, a ratio-changing system is necessary in which, if the negative feed is slowed down, the positive feed is increased simultaneously so that total carbon feed and constant current are maintained.

An ideal feed system would be one in which one control determined the total

[†] J. Soc. Mot. Pict. & Tv Eng., Feb. 1951.

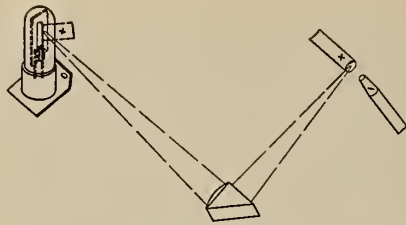

FIG. 1. Carbon position-detecting optical system, showing prism lens and bimetallic switch.

feed and the other control determined the ratio between positive and negative feeds. With a system of this type, the total feed control could be set for the desired amperage, and the ratio control adjusted until the feed ratio matched the burning ratio. This second adjustment would not affect the feed-control setting.

Thus, for example, with a 7-mm negative and 8-mm positive copper-coated, high-intensity trim the total burning rate for both carbons at 70 amps is approximately 20 in./hr. The current selector would be set to produce this total rate of feed. Then the ratio control would be adjusted, until the position of the burning tip of the positive carbon in relation to the optical system was correct and its relative movement reduced to zero.

It thus might be found necessary to adjust the ratio control setting so that the negative feeds 4 in./hr., and the positive, 16 in./hr.; or the negative might be fed 4¼ in./hr., and the positive, 15¾ in./hr. In either case the total feed would remain at 20 in./hr., and the arc current at 70 amps.

An ideal feeding system can be realized with the use of a two-motor drive. One motor, the feed motor, drives both carbons through a differential gear drive. The second, or rate-control motor, is connected preferably in the negative drive. The resultant difference in drive between the feed motor and the rate-control motor is transmitted to the positive carbon feed. Gear ratios are chosen so that the resultant total feed of both carbons is, at all ratios, a constant as determined by the speed of the main drive.

Need for Automatic Position

This feeding system and almost all present arc feeding systems make an assumption that there will be little or no variation in arc gap length, carbon-burning rate or power supply voltage. However, in practical experience these ideal conditions are seldom satisfied.

Variations in carbon-burning rates and ratios at a given current, of course, directly reflect a change of position of the arc with respect to the lamphouse optical system. Arc-gap lengths at identical currents, and even with constant applied arc voltage, will vary from trim and even within a trim.

With constant arc current, the dependent variable that compensates for variation in arc supply voltage is the arc-gap length. As the positive carbon has the highest burning rate (being approximately 2 to 8 times that of the negative carbon), the major adjustment in position for variations in arc-gap length occurs in the position of the positive carbon. Thus, variations of arc voltage or gap length directly affect the position of the positive crater in relation to the optical system.

Therefore, to adopt the ideal carbon-feed system to these practical considerations, there must be introduced an element that will maintain the positive crater at the optical focal point regardless of variation in arc gap or burning rate.

Bimetal Control Element

It is, therefore, practical to introduce a carbon crater position-detecting and ratio control-actuating mechanism into this system to accomplish this end. The bimetallic element with its ruggedness and simplicity seems to be most practical for this position detector.

This bimetal switch is simply arranged to shunt out a series resistance in the ratio-motor field circuit. With all resistance shunted out, the ratio motor runs at a speed such that the negative carbon is fed at a rate below its burning rate, and the positive is fed at a rate above its burning rate. When the resistance is inserted by action of the bimetal switch, the negative is fed at a rate above, and the positive at a rate below, its burning rate.

Total rate of feed at any selected amperage is obtained from the main-drive motor, and the position of the positive carbon is accurately maintained with the controlled variation of the ratio motor.

With the use of angle-trim lamps, the general considerations for constant illumination remain the same, with the exception that to maintain this even illumination the feed rate of the negative has to be corrected for its angular direction before it can be added to the positive to obtain the value for combined total feed.

It has been confirmed by experiment that, within a reasonable limit of movement, if the positive carbon is underfed a certain amount, X , an overfeed of the negative equal in amount to $X \cos \alpha$ will maintain constant arc current, where α is the depression angle of the negative in relation to the positive.

Taking advantage of the uniform and predictable speed characteristics of the D-C shunt motor, it is possible to design an electrical differential motor feed circuit whereby the use of the mechanical differential is eliminated. With this arrangement, each carbon is driven by a separate motor. Such a system, without an automatic position-control switch, would contain two controls, each consisting of two rheostats connected in mechanical tandem.

Each of the rheostats in the total feed-rate control would be connected in the field circuit of its respective motor, and the resistance values arranged so that the carbon-feed speeds were changed approximately in their correct values throughout the entire current range of the carbons.

The ratio-control rheostats would be connected in the two-motor field circuits in such a manner that as the ratio control was advanced, the positive feed motor would be slowed and the negative feed motor would be speeded the correct amount to maintain the same current in the lamphouse.

For automatic positioning, the bimetal-

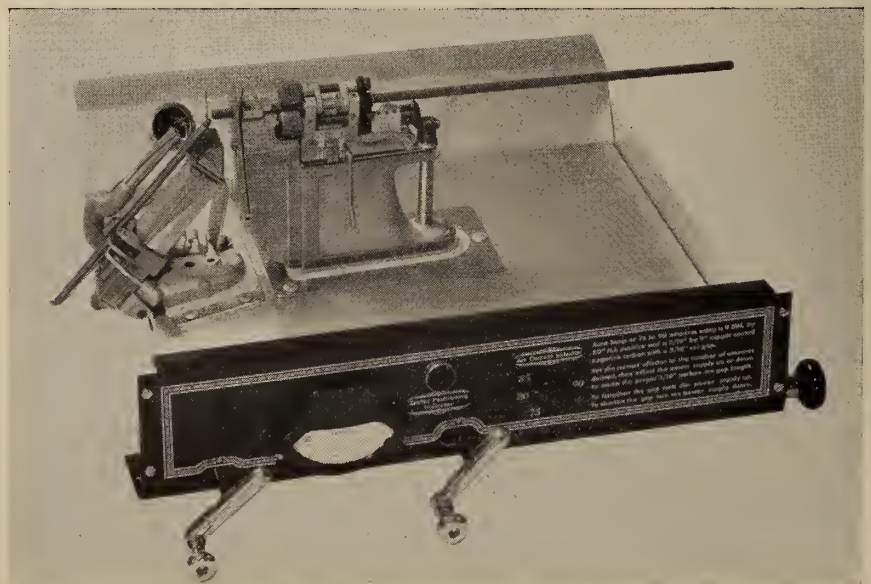
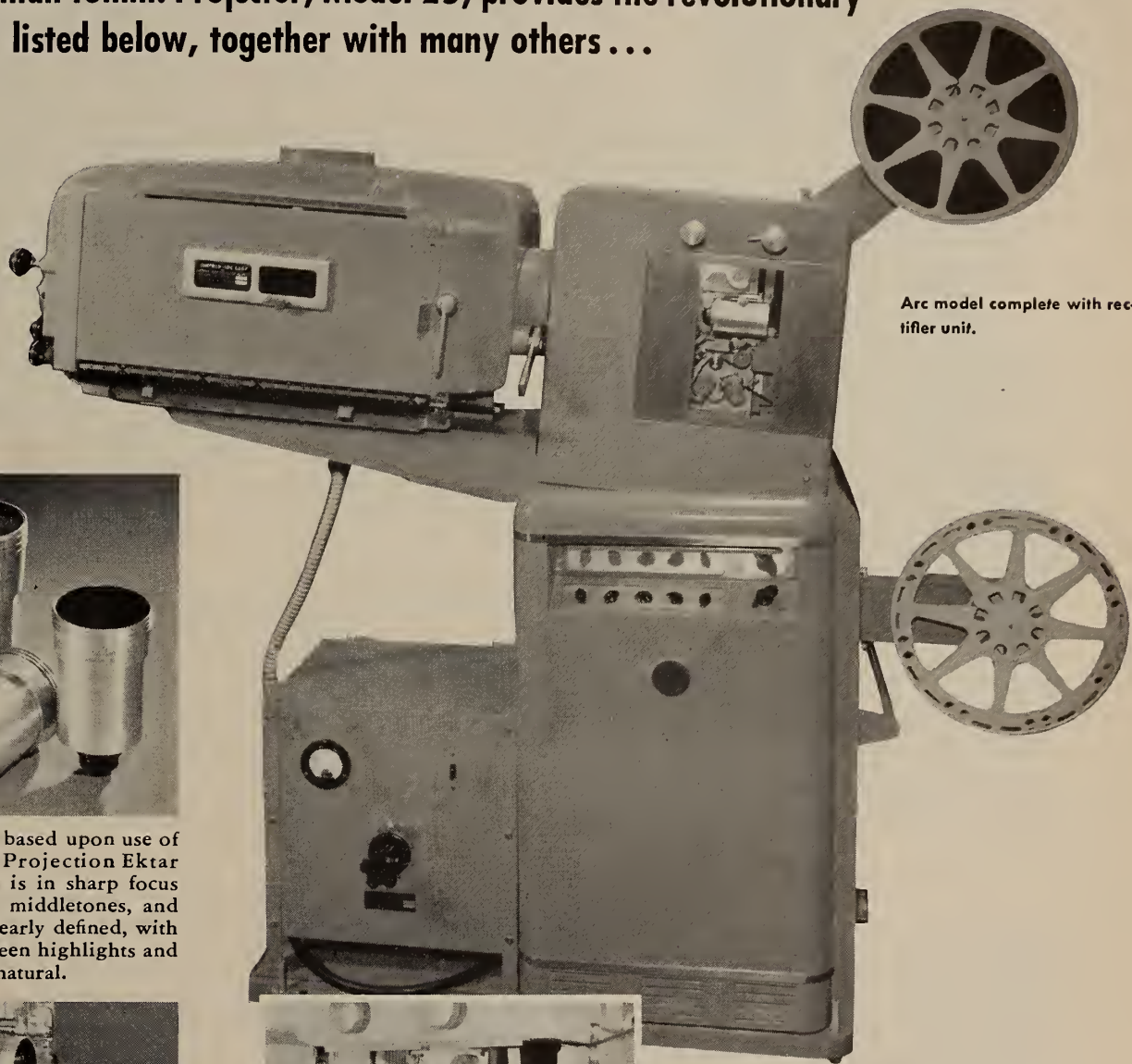

FIG. 2. General view of differential feed burner from operating side, showing positive and negative feeds and the single adjustment control.

Exclusive with this projector...

Only the Eastman 16mm. Projector, Model 25, provides the revolutionary new features listed below, together with many others...



Arc model complete with rectifier unit.



New Optical System based upon use of *Lumenized* Kodak Projection Ektar Lenses. The picture is in sharp focus overall. Highlights, middletones, and shadow areas are clearly defined, with range of tones between highlights and shadows complete, natural.

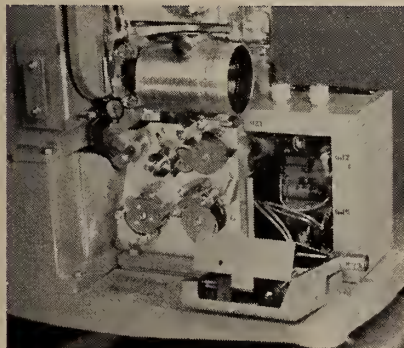

New Sound Reproduction employing "slitless" type sound optical system. Special curved cylindrical lens element forms intermediate image which is imaged on film at further reduction of 3 to 1, giving flat image of uniform width and constant intensity.

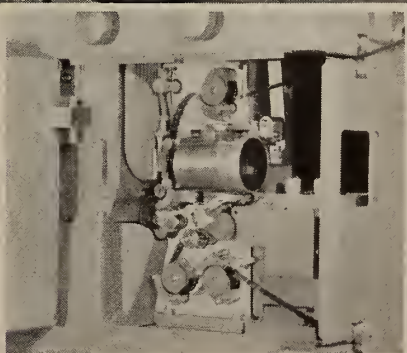

New Heavy-Duty Mechanical Design establishes new standards of 16mm. performance. For example: shock forces in each essential kinematic unit are isolated; accelerators in intermittent system are cushioned; geneva star movement is of advanced design.

For further information and prices, write for copy of new 16-page book, "Theater Quality 16mm. Projection."

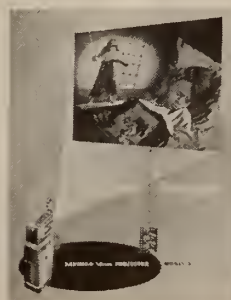

Motion Picture Film Department
Eastman Kodak Company
Rochester 4, N. Y.

East Coast Division
342 Madison Avenue
New York 17, New York

Midwest Division
137 North Wabash Avenue
Chicago 2, Illinois

West Coast Division
6706 Santa Monica Blvd.
Hollywood 38, California



ADMISSION
 Orch. and Balc. 0.50
 Logs 0.60
 Children and 12 0.25
*tax incl.

MONEY SAVED BY SKIMPING ON STUDIO LIGHTING: ————— \$30,000
MONEY LOST AT THE BOX OFFICE: \$1,000,000

Here is a sad story. A movie maker tries to save money—he cuts his studio lighting budget by \$30,000. And what does he get?

The movie is muddy. It has poor color values. People must squint to see it — and word gets around! The picture grosses \$1,000,000 less than it should have.

**MORAL: YOU CAN'T SKIMP ON STUDIO LIGHTING...
 WITHOUT RISKING BOX OFFICE!**

NATIONAL CARBON COMPANY

A Division of

UNION CARBIDE AND CARBON CORPORATION

30 East 42nd Street, New York 17, N. Y.

District Sales Offices: Atlanta, Chicago, Dallas, Kansas City, New York, Pittsburgh, San Francisco

IN CANADA:

National Carbon Limited
 Montreal, Toronto, Winnipeg

The term "National" is a registered trade-mark of Union Carbide and Carbon Corporation

USE THE

NATIONAL

TRADE-MARK

CARBON ARC!



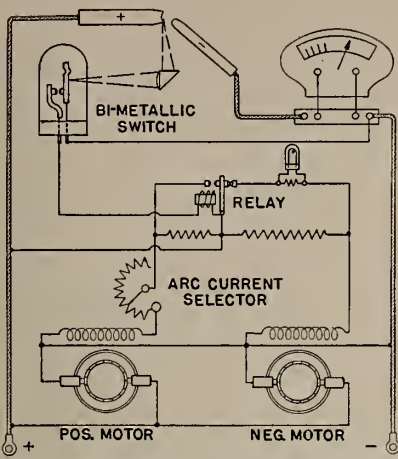

FIG. 3. Simplified arc control circuit diagram.

lic element would be arranged to shunt in and out portions of this ratio-control rheostat. The general optical arrangement for projecting the energy image of the positive carbon and flame to the bimetallic switch is shown in Fig. 1. The 90° prism with a lens ground in one face is used to direct the side view of the arc to the glass-enclosed bimetallic switch.

Single-Feed Control

It is possible to obtain D-C shunt motors with speed characteristics such that as the arc voltage is raised, consistent with higher arc currents, the negative feed motor will increase in speed approximately the right amount to compensate for the increased negative burning rate.

This fact, in conjunction with the use of a fairly large speed differential on both motors, controlled by means of the position-sensitive device, has enabled considerable simplification of the control circuit.

The net result has been the development of a circuit in which complete control of both carbon feeds throughout their entire amperage range has been accomplished with hut a single lamp-house feed-control adjustment. This control is in the form of a single rheostat which is provided with a pointer and a scale-indicating arc amperages.

The general arrangement of components of a burner incorporating this two-motor, single-control feed system as viewed from the operating side is shown in Fig. 2. A simplified wiring diagram of this system is shown in Fig. 3.

The rheostat is connected in the positive feed motor field circuit and has a value sufficient to control the feed of the positive carbon through a range of from 14 to 32 in./hr.

The bimetallic switch is connected in such a manner that in its open position a resistor is inserted in the positive field, and a resistance is shunted out in the negative field, thus speeding the positive and simultaneously slowing the negative.

When the bimetallic switch is closed by reason of the positive carbon position being slightly too near the optical system, the resistor in the positive field circuit is shunted, and the resistor is simultaneously inserted in the negative field circuit, thus slowing the positive and speeding the negative.

The positive motor will change speed sufficiently with this cycling to change the feed rate by approximately 4 in./hr. from fast to slow rate. With the negative carbon being depressed at an angle of 52°, its feed rate is arranged to change $4 \times \cos 52^\circ$, or approximately 2.5 in./hr. from fast to slow.

When the arc current selector rheostat is set at the desired current, the positive motor assumes a speed such that the average speed between high- and low-cycle speeds is equal to the average burning rate of the positive carbon at the selected current.

If the arc current at a particular in-

stant is slightly less than the selected current, the positive burning rate will be slightly lower than the average positive feed rate. Consequently, the arc position-control switch will remain in the low-speed positive feed position longer at a time, than in the high-speed positive feed position. This will cause the negative to be fed at a greater average rate than it is being consumed, thereby shortening the arc gap and raising the current, until an equilibrium condition is reached, at which the average negative and positive burning rates equal the average feed rates. This will be realized at approximately a 50% division of time on high and low speeds.

If the arc current, and consequently the positive burning rate, is higher than the selected rate, the arc position-control switch will remain in the high-speed position longer at a time than in the low-speed position. This will cause the negative to be fed at a lower than average

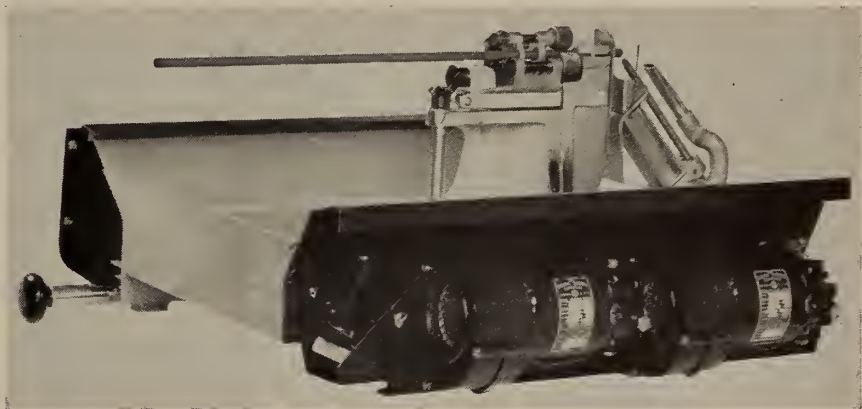

FIG. 4. General view of burner from non-operating side, showing motors and bimetallic switch behind left motor.



FIG. 5 (a). The arc burning with no air supplied from jet, the characteristic long tail-flame reaching toward the optical system.



FIG. 5 (b). The burning arc, showing how the application of air from the jet shortens and redirects the flame.

rate, thereby lengthening the arc gap until equilibrium is reached.

Slow changes in power supply voltage are compensated for by the automatic resulting change in arc-gap length, but with the continual maintenance of the positive crater at the required position.

Miscellaneous Features

Secondary considerations in connection with the realization of the two-motor automatic positioning drive include the provision of centrifugal fans on each of the motors (see Fig. 4). These fans exhaust into the burner base enclosure, from where the air is directed up through the rotating positive feed head, and against the negative feed head, thereby keeping these parts at low operating temperatures.

Immediately above and parallel to the negative carbon is located a jet tube which directs a stream of air at the arc tail flame immediately above the crater.

This device has several useful functions in that it shortens and redirects the tail flame away from the reflector, as shown in Fig. 5. The white ash product of combustion of the arc is blown away from the reflector, thereby eliminating deposit on the reflector and the consequent breakage caused by heat differentials.

Another benefit derived from the air jet is that it supplies enough additional air to the vicinity of the arc that upon striking the arc the soot particles are consumed instead of being released to the reflector surface, or lamphouse interior.

Finally, the air jet causes the blending of the negative and positive flames and results in excellent stabilization of the arc without the use of an auxiliary magnetic field. Thus, with the embodiment of the differential concept of carbon feed which was developed for the purpose of obtaining uniform feed in conjunction with automatic positioning of the positive crater, it is possible to stabilize the burning of the arc and keep the products of combustion from the lamphouse optical system.

Expand Cron-O-Matic Sales

The recent appointment of additional theater supply dealers for the new Cron-O-Matic carbon saver provides this unit with nation-wide distribution. This unit, which is adaptable to Ashcraft "D," Brenkert Enarc, Peerless Magnarc, and Strong Mogul arclamps, uses carbon stubs of all lengths, with no preparation required.

Steadily increasing interest in this device is believed to reflect, in part, the desire of theaters to conserve their supply of carbons which have the heavier copper coating. A brochure on this device is available from Payne Products Co., 2454 West Stadium Blvd., Ann Arbor, Mich.

Report on SMPTE 69th Convention

MEETING in an atmosphere charged with not a little uneasiness because of the troubled international situation and the requirements of the national defense program, the Society of Motion Picture & Television Engineers offered a varied program of papers and demonstrations at its recent 69th semi-annual convention at the Hotel Statler, New York City. Particularly concerned anent the critical materials situation were the equipment manufacturers and the film theater groups.

Nathan Golden, film division director for the NPA and principal opening day speaker, warned that diversion of essential materials for defense will be progressively greater in the months ahead. With respect to the effect of shortages on the civilian economy, he held out hope that defense orders "now totaling billions of dollars" would soon relieve the situation.

Scouting rumors to the contrary, Golden declared that there is at present no shortage of motion picture film.

Industry Ignores Technical Advances

Producers and exhibitors of motion pictures were urged by Peter Mole, Society president, to take advantage of existing technical advances which, he said, would help to maintain motion pictures as the greatest medium of mass education and entertainment.

"Technical contributions already at hand," said Mole, "are so far ahead of the industry's willingness to adopt them that the lack of interest may have the effect of applying a brake on future technical growth." These advances which are now available, he said, include not only television but also multiple sound tracks, wide-angle pictures, stereoscopy, and increased use of color.

NOTABLES AT SMPTE MEETING



Nat Golden, NPA official, who was the principal speaker on opening day, chats with Pete Mole, Society president.

The approach of producers and exhibitors to these technical advances, he concluded, must not be "What will it cost?" but "How can it benefit the industry?"

New Visual Presentation Form

The conventional indoor motion picture theater can re-establish itself as a unique medium of mass entertainment if exhibitors and producers of motion pictures will resume where they left off when sound was introduced more than twenty years ago, and adopt advanced techniques of visual presentation for which only the indoor theater has facilities. This was the advice of Ben Schlanger, noted theater architect.

By using larger screens and stereophonic sound, in conjunction with the development of more flexible screen cinematography, based on known factors of psycho-physical vision, Schlanger said, the familiar movie house can offer patrons a type of entertainment experience for which home television and drive-in theaters are not equipped.

Schlanger suggested the use of screens large enough to fill most of the patron's field of vision, giving him the illusion of participating in the scene instead of viewing it through a "window." The full width of the screen would be used for panoramic scenes, but during concentrated action in any one portion of the picture, detail and brightness in the rest of the screen area would be reduced, conforming to the experience of the eye in normal vision.

In viewing a "live" scene, Schlanger pointed out, we are aware of objects in a wide field of vision until some sound or motion concentrates our attention on a narrower field. We then observe detail only in the field of concentration, although we remain aware of light, shadow, and color in surrounding areas.

Schlanger declared that this type of presentation can be effected with existing studio and theater equipment.

'Synthetic' Vision of Future

Synthetic vision "almost as remarkable as natural vision" in its depth perception and other characteristics will be achieved in motion pictures and television, it was predicted by Major R. V. Bernier of the Wright-Patterson Air Force Base in Dayton, Ohio. Addressing a symposium on high-speed photography, Major Bernier described and demonstrated a new technique combining three-dimensional effects with full color and high-speed, normal-speed, and time-lapse photography.

In one novel scene in the demonstration film, a tray of refreshments appeared

(Continued on page 24)

Just a few of the many users of STRONG TROUPER SPOTLIGHTS

THEATRES

State, Sycamore, Ill.
Congress, Saratoga, N. Y.
Paramount, Syracuse, N. Y.
Olympic, Watertown, N. Y.
Victory, New London, Conn.
Howard, Washington, D. C.
Grand, Evansville, Ind.
Campus, Denton, Texas
Miracle, Coral Gables, Fla.
Miami, Miami, Fla.
Valley, Cincinnati, Ohio
State, Baltimore, Md.
E.A.R., Chicago, Ill.
Oriental, Denver, Colo.
Dream, Kansas City, Mo.
Crest, Fresno, Calif.
Broadway, Charlotte, N. C.
Bijou, Montreal, Que., Can.
Huntington, Huntington, Que., Can.

HOTELS

Statler, Washington, D. C.
Copley Plaza, Boston, Mass.
Palmer House, Chicago, Ill.

TV STUDIOS

WGN-TV, Chicago, Ill.

ARENAS

Hershey Arena, Hershey, Pa.
Hobart Sports Arena, Troy, Ohio
Chanute Air Force Base, Rantoul, Ill.
Sports Arena, Toledo, Ohio
Community Centre Ice Arena,
Sudbury, Ont., Can.
Springfield Hockey Rink,
W. Springfield, Mass.
Grand Rapids Stadium, Grand
Rapids, Mich.

COLLEGES

Univ. of Denver Field House, Denver,
Colo.
Univ. of Kentucky Coliseum,
Lexington, Ky.
Rensselaer Polytechnic Inst., Troy,
N. Y.

ICE SHOWS

Ice Vogues
Ice Capades
Holiday on Ice
Ice Cycles
Ice Parade
International Ice Review

LODGES

Masonic Temple, Hammond, Ind.
Medina Temple, Chicago, Ill.
Scottish Rite Temple, Dayton, Ohio
Zembo Shrine, Harrisburg, Pa.

INDUSTRIES

Anaconda Copper Mining Co.,
Anaconda, Mont.
Coca-Cola Bottling Co., Du Quoin, Ill.
Eastman Kodak Athletic Assn.,
Rochester, N. Y.
Pontiac Motor Div. Gen. Motors,
Pontiac, Mich.

TRAVELING SHOWS

Gene Autry
Skating Vanities

AUDITORIUMS

Peabody Auditorium, Daytona Beach,
Fla.
The Coliseum, Sioux Falls, S. D.
Corn Palace, Mitchell, S. D.
Milwaukee Auditorium, Milwaukee,
Wis.
Civic Auditorium, Seattle, Wash.
Civic Auditorium, San Jose, Calif.
Municipal Auditorium, Ft. Lauderdale,
Fla.
Lynn Memorial City Hall, Lynn, Mass.
Sioux City Auditorium, Sioux City, Ia.
Municipal Auditorium, Birmingham,
Ala.
City Auditorium, Jackson, Miss.

Drawing only 10 amperes from any 110-volt A.C. convenience outlet, the Trouper makes the use of heavy rotating equipment unnecessary. With an adjustable, self-regulating transformer an integral part of the base, the Trouper is ideal for traveling shows. Mounted on casters it's easily portable and readily disassembled for shipping.

The high efficiencies of the Trouper are largely attained by the optical system which utilizes a silvered glass reflector and a two-element variable focal length lens system. The automatic arc control maintains a constant arc gap, free from hiss or flicker. A trim of carbons burns one hour and 20 minutes at 21 volts and 45 amperes.

THE NEW STRONG TROUPERETTE INCANDESCENT SPOTLIGHT

... for small theatres, schools, night clubs, TV studios and industrial shows; where physical dimensions and price are factors and where the tremendous light volume of an arc lamp is not necessary.

PROJECTS FAR MORE LIGHT THAN ANY CONVENTIONAL, INCANDESCENT SPOTLIGHT

This increased brilliancy is made possible by a variable focal length objective lens system, a 5¼-inch silvered glass reflector, and Fresnel lens used with a standard 115-volt, 1000-watt prefocused projection type bulb.

As contrasted to the conventional incandescent spotlight, with which the spot size is varied solely by iris, to result in substantial light loss, the Trouperette utilizes all the light through most of the spot sizes.

6 1/2 TIMES BRIGHTER HEAD SPOTS

Sharp edges from head spot to flood. Horizontal masking control can be angled at 45 degrees in each direction. Fast-operating color boomerang accommodates six slides. Height-adjustable mounting stand.

Can be plugged into any 110-volt convenience outlet.

THE STRONG ELECTRIC CORPORATION

"The World's Largest Manufacturer of Projection Arc Lamps"

14 CITY PARK AVENUE

TOLEDO 2, OHIO

Please send free literature on the Strong Trouperette
Incandescent Spotlight; Strong Trouper Arc Spotlight.

NAME

COMPANY

STREET

CITY & STATE



Here's Your Cue

When buying spotlights follow
the lead of those who know
a sharp, dazzling snow-white
spot when they see one... buy,

STRONG TROUPER

High Intensity Arc SPOTLIGHTS



The Men Behind the Show

are behind

Simplex
TRADE MARK REG'D

X • L

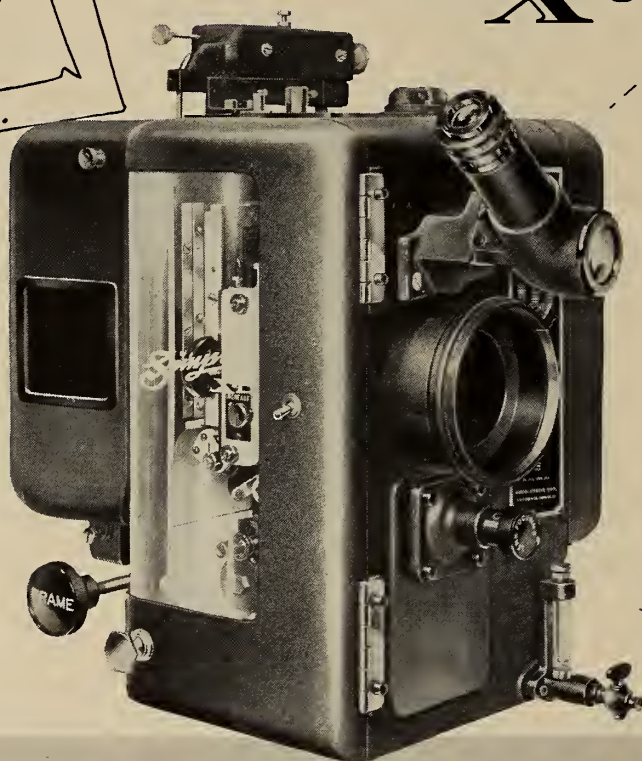

Simplex
TRADE MARK REG'D

X • L

THE PROJECTIONIST'S
PROJECTOR

To the people out front enjoying a motion picture, you're the forgotten man. But you're the fellows who make these pictures possible, and you're the fellows who know *better projection pays!*

TO RELAX SEE A MOVIE.

MANUFACTURED BY INTERNATIONAL PROJECTOR CORPORATION • DISTRIBUTED BY NATIONAL THEATRE SUPPLY

The Magic of Color

By ROBERT A. MITCHELL

The first of a series of three articles on the "what," "why" and "how" of color.

THE projectionist is intimately concerned with color. The projection of natural-color films, the effect of extraneous sources of colored light upon the appearance of projected pictures, and the color schemes employed in stage and auditorium decoration are encountered by the projectionist almost daily. Then, too, the projectionist has a very understandable interest in the various methods of photographing and printing colored films.

Color is by no means the easiest thing in the world to understand; but the subject is made much simpler by completely ignoring controversial theories of color vision and abandoning the classical approach to its study. Moreover, it is absolutely necessary to employ different names for different colors, the same names for the same colors, and to specify exactly what is meant by red, orange, yellow, green, etc. Let's avoid the mistakes of the past.

The Visible Spectrum

To see colors in their greatest degree of purity we naturally turn to the *visible spectrum*, a band containing all of the wavelengths of light from 740 to 360 millimicrons (red to violet) spread out in order.

Figure 1 illustrates a "normal" spectrum, such as that produced when homogeneous white light is analyzed by means of a diffraction grating, a plate of polished metal ruled with from 10,000 to 20,000 fine lines to the inch. A glass prism also produces a spectrum, but the grating spectrum is better for our purpose because equal intervals along the varicolored band correspond to equal differences in wavelength. A prism spec-

trum stretches out the violet end of the band and contracts the red end.

The red of the spectrum, however, is a deep orange-red, not true red. True red—the "reddest red"—cannot be found anywhere in the spectrum!

This statement may seem very strange to anyone who has ever observed the brilliant spectrum colors. The color contrast between the two ends of the spectrum is so great, however, that the eye is deceived into seeing the orange-red as real red, and the violet as a pronounced purple. Cover up from view all of the spectrum except the red end (610 millimicrons to infrared), and it will be seen that spectrum red corresponds exactly to the dull red of a glowing cigarette.

Intensities of Hues

All of the spectrum "colors" from 610 millimicrons down to the limit of visibility are actually only different intensities of the *same hue*! It is a fact that dark orange-red looks redder than bright orange-red.

The distinctive name of spectrum red is *vermilion*.

Passing along the spectrum from vermilion toward violet, we find a narrow band of orange hues, a very narrow band of yellows, a broad band of greens, and beyond this a region containing violet-blues and violets.

True purple, the reddish purples, and the purplish reds, like true red, are missing from the spectrum. The spectrum, therefore, comprises only an incomplete collection of hues.

It is common knowledge that by mixing together paints of different colors, or colored lights, we get new colors—even colors which cannot be found in the spectrum. This fact, together with the knowledge that only a limited number of fundamental hues (*saturated colors*) are needed to produce *all* of the colors which the human eye can see, led to the theory that human vision distinguishes one color from another by the relative degrees of optical stimulation of a limited number of color-perceptive centers in the eye.

The pure hue which stimulates one color center, but not any of the others, is called a *primary* hue.

From this theory it follows that colors not primary colors produce their characteristic visual sensations by the combination of two or more primaries.

Basic Hues for Color Vision

This theory, which can be tested in various ways, is today an established fact. But how do we know how many primaries there are, or what colors they are? Experiments with colored lights demonstrate that all colors can be produced with a minimum of three pure hues in various combinations. There are thus

FIGURE 1

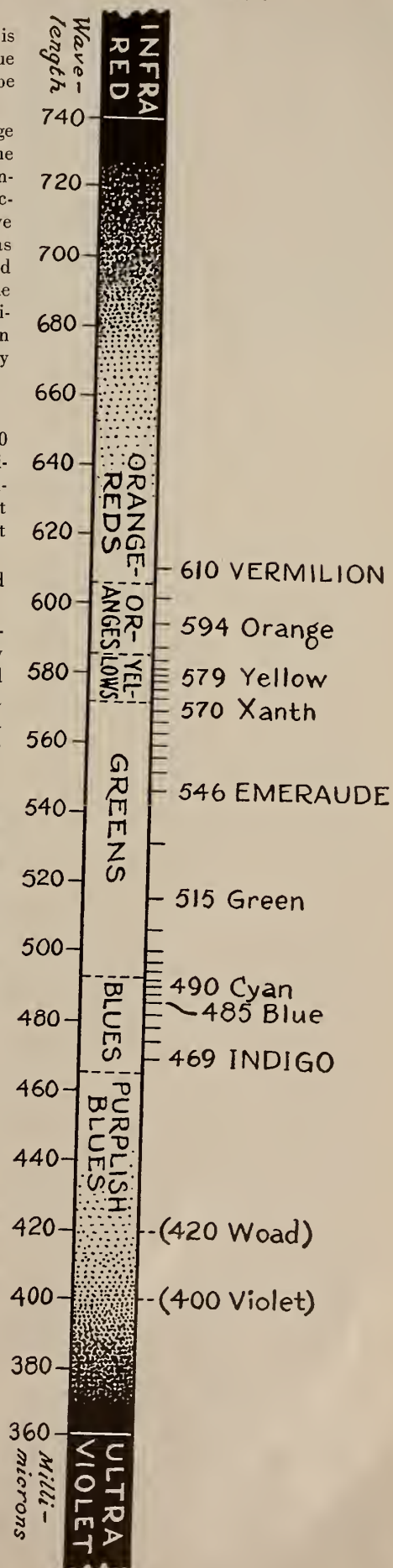

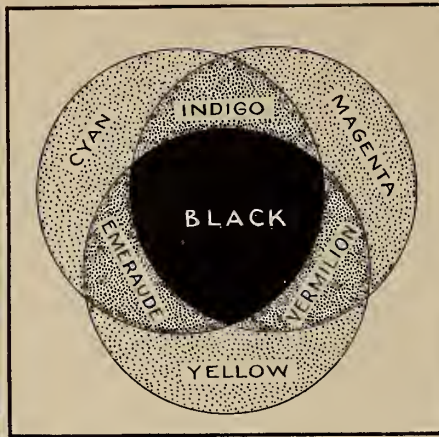
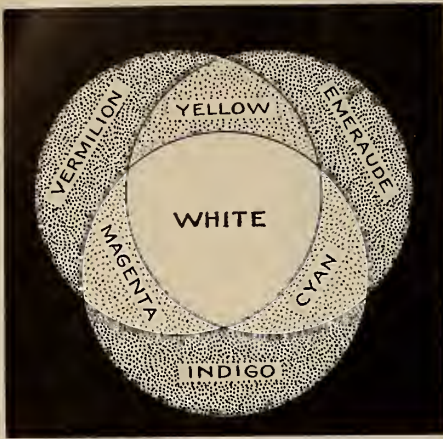

FIGURE 2

The addition of lights of the three primary colors.

The subtraction of primary colors from white light by filters.

three primary colors. It has also been determined that the various colors are reproduced perfectly only when the primaries are such that no possible combination of any two of them will reproduce the third.

The three hues which have been established as fulfilling all the requirements of human *trichromatic* color vision are vermilion (610 to 740 millimicrons), emeraude (546 millimicrons), and indigo (469 millimicrons).

VERMILION is a deep orange-red

EMERAUDE is a slightly yellowish green

INDIGO is a deep violet-blue

These hues are commonly called "primary red," "primary green," and "primary blue," even though they do not correspond to "true" red, green, and blue.

If three lights are set up close together—one vermilion, one emeraude, and one indigo—any conceivable color can be reproduced on a white screen. If the relative intensities of the three lights are correctly balanced, the screen will appear *white* when all three lights are turned on.

By turning off the indigo light, a pure *yellow* light is seen—the combining of equal intensities of vermilion and emeraude. Vermilion and indigo make a purplish red called *magenta*; while emeraude and indigo together make a slightly greenish blue called *cyan*.

Because yellow is the opposite of indigo (yellow and indigo lights together make white), yellow and indigo are said to be *complementary* colors. Likewise, magenta is complementary to emeraude, and cyan is complementary to vermilion.

The Subtractive Primaries

Yellow, magenta, and cyan are sometimes called secondary colors. Artists and printers often refer to them as (subtractive) primaries.

YELLOW: Process yellow, Chrome yellow, "Minus indigo."

MAGENTA: Process red, Rose, "Minus emeraude."

CYAN: Process blue, Turquoise, Peacock, "Minus vermilion."

The left-hand panel of Fig. 2 shows the effect of combining circular spots of V, E, and I light in slightly displaced positions. Note that the three primaries superposed give white.

Similar, *but reversed*, color effects are obtained by superposing in displaced positions circular Y, M, and C color filters and viewing them against a clear field of white light. This is shown in the right-hand panel. Note that the three secondaries thus superposed give black. Fig. 2 therefore illustrates both *additive* and *subtractive* color formation. The latter is explained in terms of the three primary hues.

Take, for example, the formation of emeraude by combining yellow and cyan

filters. The yellow filter subtracts I from white light and lets V and E pass. The cyan filter subtracts V, and lets E and I pass. When the yellow and cyan filters are overlapped, the cyan filter cuts off the V light passing through the yellow filter, and the yellow filter cuts off the I light which would otherwise pass through the cyan filter. Only E light gets through both of them, so the resulting color is emeraude.

Definition by Wavelength

Most hues can be defined by their wavelength in the spectrum. Yellow, for example, has a wavelength measured as 579 millimicrons. Yet, as far as the human eye is concerned, an equalized mixture of vermilion (610) and emeraude (546) produces exactly the same color sensation as yellow (579). The two yellows which look alike, even though they have different spectral compositions, are called *metamers*.

Mixing vermilion and indigo lights in different proportions results in the production of *non-spectral* purples and reds. The non-spectral hues comprise about 36% of the total number of hues.

The "wavelength" of a non-spectral hue is usually designated as the negative wavelength of its complementary. Thus magenta, which has no real wavelength because it does not occur in the spectrum, is designated as -546 millimicrons, the negative value of the wavelength of emeraude, the complementary of magenta.

Wavelength, however, is not the most accurate definition of a hue. For example, the wavelength of cyan is 490 millimicrons. But the cyan of the spectrum appears somewhat different *in the middle*

FIGURE 3

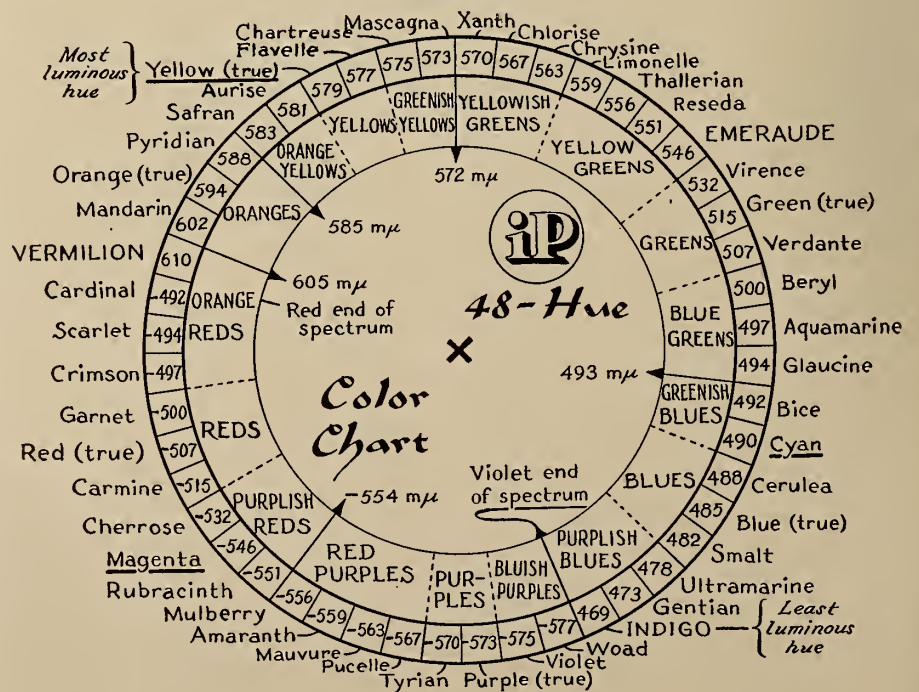

of the field of vision to certain observers from the cyan produced by combining emeraude and indigo. The disagreement of some observers on metameric color matches is due to the spectral-absorption characteristics of the "yellow spot" of the eye—the *macula lutea*.

A difficulty also arises in the case of hues more violet than indigo. It happens that the vermilion-sensitivity of the eye increases slightly in the spectral region beyond indigo, giving rise to such bluish purples as *woad* and *violet*. But observers seldom agree on the wavelengths which should be assigned to the hues lying between indigo and ultraviolet. For this reason both woad and violet are best regarded as non-spectral colors and assigned the wavelengths of —577 and —575, respectively. (The complementaries are *flavelle 577* and *chartreuse 575*.)

We conclude that colors are best defined not by wavelength but by the proportions of primaries required to reproduce them.

Color-Induced Optical Illusions

There are two types of optical illusion produced by color. The most spectacular one depends upon the tendency of the eye to adjust its color sensitivity toward the complementary of the predominating hue in any colored object or light which is looked at for any length of time. This is sometimes called "color fatigue," sometimes "simultaneous contrast," depending upon the conditions which produce the illusion.

This peculiar property of the eye also makes colors appear the most vivid when placed in close proximity to their complementaries. Thus, pure blue looks bluer in close proximity to orange than when viewed by itself.

Place a red disk upon a sheet of white paper and gaze at the center of the colored disk for about half a minute. Then suddenly divert the gaze to a blank area on the white paper. A bluish green disc will gradually appear on the paper where there is no color! The red and bluish green are complementary colors. The same experiment may be tried with other hues. A bright yellow disk, for example, will create an apparitional blue-violet disk.

"Simultaneous contrast" is similar. A white movie screen surrounded by blue lighting, for instance, appears slightly orange, or yellowish. Incandescent light, decidedly yellow when compared with daylight, "whitens out" by virtue of increased blue-sensitivity as we become accustomed to it.

The 'Purkinje Effect'

The second color illusion involves a slight apparent, or "seeming," change in hue with differences in intensity. This is due to the "Purkinje effect."

Theater Equipment and NPA Regulations

AS A service to the manufacturers of motion picture theater equipment, no less than to the theaters themselves, IP desires to stress the appended points relative to National Production Authority regulations applicable to both new construction and the purchasing of various replacement units of equipment.

1. Equipment should be purchased NOW while reasonable delivery terms may be obtained.
2. There is no limit to the amount of money that an exhibitor may spend for most theater equipment.
3. The exhibitor needs no preference ratings for the purchase of equipment at the present time.
4. It is possible for a theater owner to obtain NPA permission to spend more than \$5000 at one time on alteration and modernization of his theater by making application to NPA on Form F-24.
5. Acceleration of the defense effort will create shortages of material that will decrease the manufacture of theater equipment to a comparatively small percentage of normal supply.

NPA has published the most detailed list of various classifications of equipment, and it would be well if every theater in the country had this list on hand against the time when their needs develop.

Suppose you have two lamps, one with a green bulb and the other with a red bulb, and that both appear equally bright. If you were to add another green and red bulb to each lamp, you would logically expect to see the two lamps still equally bright. Actually, the red lamp will seem to be brighter than the green one.

The eye reacts differently to equal variations in the intensity of green and red.

Emeraude is apparently affected least by actual changes in intensity; vermilion the most; and indigo lies between the two.

How does the Purkinje principle affect the apparent hue of certain colors? Take the case of yellow, a combination of vermilion and emeraude light. Darken to a considerable degree some *true* yellow paint by adding neutral black paint to it. Instead of obtaining a yellowish brown, as might be expected, the resulting color will be a slightly greenish gray-brown. The vermilion component of the yellow decreases more rapidly than the emeraude (apparently) as the black is added, thus shifting the dominant hue from true yellow to faintly greenish yellow (*flavelle* or *chartreuse*).

Size, Luminosity, Surroundings

Most other alleged color illusions involve the relation between the apparent size of colored objects and the luminosity of the objects and their surroundings. These are not color illusions, strictly speaking, since they can also be produced in black-and-white. And still other

so-called color illusions simply fail to work for most observers.

A *hue* may be defined as a *saturated* color, a color produced by one primary alone or by two primaries in various combinations—never three. This, of course, refers to mixtures of colored lights. When paints or dyes are mixed, the laws of subtractive color formation hold good, and the secondaries (yellow, magenta, and cyan) must be substituted for the primaries.

The eye is able to distinguish about 200 hues—for all practical purposes exactly 192. The various combinations of vermilion and emeraude number 63 distinguishable hues, of emeraude and indigo 55, of indigo and vermilion 71. Add to these the three primary hues used alone, and the total is 192.

Strange it seems that each bicolor "set" yields a different number of differentiable hues; but the Purkinje principle offers an explanation. Human vision is not equally sensitive to equal variations in the intensity of the three primaries. This fact must be taken into account whenever an attempt is made to devise "equitempered" hue scales—color charts which are based upon equal color differences from hue to hue.

Color Notation Systems

The very widely used, but archaic and unscientific, Munsell Colour Notation System ignores equal hue differences and certain other prime requisites of a perfect color system. Small wonder that practical color technology is in a state

(Continued on page 29)

IN THE SPOTLIGHT



By
**HARRY
SHERMAN**

MOST encouraging was the renewed interest in practical projection exhibited at the recent semi-annual convention of the SMPTE, held in N. Y. City. Not only was the papers programs generously larded with projection topics, but there was the best representation of projection people we have seen at any SMPTE gathering in several years.

We have felt that for all too long the importance of projection has been lost sight of by the Society. The recent convention, plus the reorganization of the Projection Practice Committee under the chairmanship of a practical projectionist—M. D. O'Brien of Loew's Theaters—did much to dispel our mounting fears anent this situation.

It is to be hoped that these developments indicate that in the future the Society will continue to accord projection the attention it deserves.

- Michael J. Mungovan, business representative for Local 25, Rochester, N. Y., wound up a career of 53 years backstage when he resigned last month from his job as chief stagehand at Loew's Rochester Theater. He will now devote his full time to his numerous union activities. In recognition of his retirement from his job at the theater, all Rochester AF of L unions affiliated with the IATSE feted Mike at a midnight party held at Rund's Restaurant.

Louis Goler, member of Projectionists Local 253, acted as master of ceremonies. Special guests on hand were James L. Burke, president of Rochester AF of L; Julius Loos, secretary of the Allied Printing Trades Council, and other AF of L members associated with Mike during his half-century service to organized labor.

Mike is a vice-president of the New York State Federation of Labor; a member of New York District No. 10 executive board, and he belongs to many State Labor Department and AF of L organizations and committees.

- A plan to combat the raiding tactics of NABET, now affiliated with the CIO, was drafted recently by a committee of representatives of every AF of L union on the West Coast interested in radio

and television. At the first meeting of this group, announcement was made of the overwhelming defeat of NABET by a vote of 10 to 0 in favor of the IATSE at radio station KFI-TV in Los Angeles. The AF of L committee will meet each week during the campaign to eliminate the CIO union from the radio and television studios. Carl G. Cooper, 7th vice-president, and Roy Brewer, special West Coast representative, are members of this committee representing the IA.

- The regular monthly meetings of the famous 25-30 Club are becoming more and more popular. Each meeting is highlighted by some special event—either an address by a prominent industry figure or a lecture and demonstration by a technical expert on the latest advances in the projection field.

Two new members were obligated at the April meeting of the Club—Harry E. Storin, vice-president of New York Local 306, and Arthur Raff, member of the Local. Among the "regulars" at the Club meetings are Admiral Tomkins and Arthur Meyer, of International Projector Corp., and Allen G. Smith, New York branch manager for National Theater Supply Co.

- Governor Paul A. Dever, of Massa-

NEW SIMPLEX X-L'S FOR ROXY, N. Y.



Allen Smith, National Theater Supply manager, and Charles Tally, director of visual and sound projection, inspect installation of three new X-L projectors in this famous Broadway house.

chusetts, reappointed Benjamin Hull, former president of Local 186, Springfield, Mass., as associate commissioner of labor. Despite heavy pressure brought to bear on the Governor to name a Democrat to replace Hull, a holdover from the former administration, he refused to yield and reappointed Hull for another term.

- Our very good friend Herbert Aller, business representative of Cameraman's Local 659 (Hollywood), won a public speaking contest at the graduation exercises of the Industrial Relations Course at Loyola University in Los Angeles, Calif., and was awarded a medal for proficiency in oratory. Herb chose as his topic the defense of President Truman's action in removing Douglas MacArthur as supreme commander in the Far East

- H. N. Elliott, former secretary and long-time member of Toronto Local 173, and Frank Ford, member of Cleveland Local 160, were among the recent out-of-town visitors to the offices of IP.

- An attendance of about 200 celebrated the 35th anniversary party of Local 433, Rock Island, Ill., which was held May 3 at the AF of L's new Temple Club. In addition to the members of Local 433, representatives from many of the nearby IA Local Unions were present. Fred Parker, business representative of the Local, introduced the toastmaster of the evening—John H. De Young, secretary of the Tri-States Federation of Labor.

Among the guest speakers were Felix Snow, IA 6th vice-president; William Donnelly, IA representative and also business representative for Minneapolis Local 13, and Herbert D. Grove, district manager of the Tri-States Theater Corp. Grove, incidentally, is a charter member of the Rock Island Local, having been one of its organizers 35 years ago. Also present were Cliff Carney and W. E. Davis, president and vice-president, respectively, of the Tri-States Federation of Labor; Herb Weinberg, editor of the *Labor Review*, and Gabriel Germaey, Federation board member.

- Roy M. Brewer, IA West Coast rep-

representative, is chairman of a committee appointed by the Hollywood AF of L Film Council to draw up plans for the reopening of wage negotiations next October between the major producers and 14 IA Local Unions on the West Coast. An offer of 10c per hour increase for hourly workers and a flat \$7 per week increase for straight salaried workers, contingent upon the Local's agreement to advance the existing IA contract from October 1951 to October 1952, was turned down by all the Locals involved.

- News of the accidental death by drowning of J. Max Ealy, for many years secretary and business representative of Local 378, Wichita Falls, Texas, came as a shock to his many friends in the Alliance. Max and his wife, together with several friends, were fishing in Lake Kickapoo, Texas, when their boat capsized and they were thrown into the water. All but one member of the fishing party were drowned. Max's body was not found until four days later.

- Personalities at the recent SMPTE meeting: RCA's Marty Bennett was easily the handsomest man present. . . . Pete Mole, president of the Society, won the hearts of all present at the dinner-dance by making the shortest welcoming address on record—less than one minute. . . . Ed Lachman (Lorraine Carbons) has won many friends for himself and his product by his gracious and amiable personality. . . . Bill Kunzmann, as usual, was here, there and everywhere, doing his level best to keep things running as smoothly as possible. Much of the success of the gathering may be attributed to his very capable and tireless behind-the-scenes efforts. . . . The projectionist craft was represented by Charlie Dentelbeck, Toronto Local 173; Jack Sawyer, Buffalo Local 233; Herman Gelber, Harry Storin, Ernie Lang, Hyman Boritz, John Krulish, Steve D'Inzillo, Harry Garfman, Harry Hollander, Wally Byrne, and Charley Mueller (Radio City Music Hall projection chief), all of New York Local 306. . . . Loren Ryder, past president of the Society, was very much in evidence greeting his many old friends. Loren is chief sound engineer at the Paramount Studios on the West Coast, and is highly regarded in the industry.

- Organized labor in the State of New York is very much concerned about the Hughes-Brees Bill, signed recently by Governor Thomas E. Dewey. In protest against the Governor's action, Frederick F. Umhey, executive secretary of the New York State Advisory Council on Placement and Unemployment Insurance since 1940, resigned from his post, charging that "since the only sponsors of this bill

FLOYD M. BILLINGSLEY

Floyd M. Billingsley, third vice-president of the IATSE and business representative of Local 162, San Francisco, died on May 2 of surgical shock following an operation. He would have been 61 years of age on May 5, having spent 44 years in show business.

A native of Texas, Billingsley became associated with the first nickelodeon in Austin, Texas, in 1907, a few years following which he moved on to San Francisco, his home town ever since. He joined Local 162 in 1918, and was its business representative almost continuously since 1929. He was appointed an IA vice-president in 1931.

A delegate to the San Francisco Central Labor Council for the past 17 years, Billingsley served since 1947 on the World Trade Center Authority by appointment of Governor Warren of California.



were the big business interests of this State, and since it was unanimously opposed by organized labor, you have, by signing this bill, aligned yourself with big business, who will be its chief beneficiaries. . . . It will do untold harm to the small businessmen of this State and to its working population. It has removed our unemployment insurance law from the category of social legislation. . . . We will, in a short time after the Hughes-Brees law goes into operation, face a complete breakdown of unemployment insurance in this State."

- We learned that a collection of \$50,000 for the Hill Rogers Memorial Hospital at Saranac Lake, N. Y., was made at the dinner tendered IA President Walsh last month by the film industry. It may not be generally known, but a great many of the patients at this hospital are IA members from all parts of the country, and the care and attention they receive, without any charge, cannot be improved

upon even in the most expensive sanatoriums.

This is one organization that deserves the support of every theatrical union in the country.

- Organized labor in Ohio faces a new menace with the introduction recently of a bill called SB-213, which, according to the Ohio State Federation of Labor, out-Taft-Hartleys the T-H law. It is the contention of the State AF of L legal department that Section 5 of this proposed bill, which prohibits unions from denying membership except for failure to pay dues and initiation fees, might be called a "Magna Charta for communists." Many unions now refuse to accept communists as members, but under the SB-213 bill, refusal to admit them as members would subject unions to civil and criminal action.

Among the other obnoxious features of this bill is a provision outlawing all picketing, no matter how orderly and peaceful. The language of the bill is so broad that it can be interpreted as prohibiting any act or agreement which "tends to have the result" of establishing a union shop, closed shop, or hiring hall.

The sponsors of this bill imported Cecil B. DeMille, movie producer well known for his anti-union leanings, to the hearing accorded the proponents of this measure. DeMille gained nation-wide publicity when he gave up his radio show rather than submit to majority union rule.

Opponents to the SB-213 Bill will be heard at a later date, at which time we will report the final outcome of this proposal.

- Michael J. Ostrowski, veteran member of Local 233, Buffalo, N. Y., advised us of the marriage last month of his son Frank, also a member of the Local, to Amy Gawon, secretary to Dave Miller, of Universal Film Corp.

Photograph Interior of the Eye

A HIGH SPEED CAMERA for photographing the tell-tale interior of the eye is now in production. Developed after two years' research by Bausch & Lomb Optical Co., it photographs—in color or black-and-white—the retina, nerve fibers and other structural elements of microscopic size within the eye.

The only camera of its kind in production today, it was designed at the request of the U. S. Public Health Service for studies showing the relationship between enlarged retinal blood vessels and vascular diseases. The camera has also been used extensively by Dr. Walter Kempner, of Duke University Hospital, in his "rice diet" research and treatment of these diseases.

Photographs taken periodically of the interior of the eye are superimposed so that the blood vessels may be compared at various stages of treatment.

Theater Television

via the RCA PT-100 Equipment

By TECHNICAL PRODUCTS DIVISION, RCA SERVICE CO., INC.

VI. Interpretation of Image Characteristics

IN PART FIVE of this series of articles on the RCA PT-100 Theater TV Equipment, the location, function, and normal settings of the operating controls were discussed. In addition, it is desirable for the projectionist to have sufficient knowledge of the capabilities of the equipment to enable him to take corrective action and adjust the equipment controls to obtain best performance.

One of the most common causes of image degradation, when broadcast Tv signals are used, is interference pickup from the ignition systems of automobiles, buses and trucks. Street cars, sign flashers, diathermy, X-ray equipment and similar devices often radiate interference which may cause horizontal streaks across the screen. In such cases, all that can be done to the equipment at the theatre is to be sure that the receiver is properly tuned and the Tv receiving antenna is in the correct rotational position.

Signals transmitted by microwave relay link and coaxial cable are usually free from this type of interference.

Special Test Pattern Used

Where signal interference is present, or where a proper Tv signal is not being received, adjusting the controls of the PT-100 equipment cannot produce a normal picture.

Other causes of a technical nature may produce picture degradation. Any outstanding defects will be plainly seen in the projected picture. However, when critically analyzing the screen image it becomes desirable to use a special kind of picture which is designed to indicate the band width of the received signal, the resolution of the picture, and the correct adjustments of the operating controls. Such a special picture is called a test pattern.

Several different kinds of test patterns are commonly used. A typical test pattern is shown in Fig. 1. This test pattern consists of two large concentric circles with diameters in the ratio of 4 to 3. These are used for checking the adjustments of the height and width controls. When these controls have been properly adjusted, the outer circle will just touch the right and left sides of

the screen, and the inner circle will just touch the top and bottom of the screen.

Interpreting Test Pattern

At the center of the test pattern there is a small black circle surrounded by four narrow concentric rings. These are used to check the settings of the video and black level controls. When the black level control is properly set, the inner circle will be solid black, and the inner concentric ring, which surrounds it, will be somewhat lighter.

When the video control is properly set, the outer of the four concentric rings will be white and the ring just inside it will be somewhat darker. Thus, the inner circle will be black, and the rings surrounding it will successively be lighter until the outer ring is reached; this will be pure white.

If the black level control is set too low, the center black circle will have a grayish color instead of solid black. If the black level control is set too high, the inner concentric ring will be black, as well as the center circle. If the video control is set too low, the outer concentric circle will be gray instead of white. If the video control is set too high, the outer two concentric circles will both be white.

If the video control is set too high, a condition known as "blooming" may occur in the projected image. When this

occurs, the white parts of the picture will tend to spread out over the adjoining black parts, causing loss of detail and also lack of proper contrast between black and white. This resembles the well known "halation" caused by excess light on parts of a motion picture film. Ordinarily this condition will not be visible on the monitor kinescope.

Horizontal Image 'Tear Out'

Improper setting of the HOR. HOLD control will cause the picture to "tear out" horizontally. When this occurs, all or part of the picture will travel rapidly across the screen, producing a blurred jumble of picture elements. Resetting the control will correct this condition, provided the incoming signal is normal.

Also, the test pattern shown in Fig. 1 includes two pairs of wedges. Each wedge consists of a set of tapering lines extending inwardly from the large black circle to the concentric ring pattern in the center.

As these lines approach the center, they gradually become thinner and closer together. Obviously, the detail near the center ends of the wedges is finer than the detail at the outer ends, therefore these wedges will indicate the resolution of the picture.

The horizontal wedges indicate the vertical resolution, which depends on the number of scanning lines used by the Tv system. The present American scanning system uses 525 lines, which is more than adequate to reproduce the fine detail at the inner ends of the horizontal wedges.

The vertical wedges indicate the hori-

FIGURE 1
A typical Tv test pattern put on the air by the broadcast station for checking band width of the signal, picture resolution, and correct adjustment of controls.



zontal resolution, which depends on the band width of the television signal. The standard Tv broadcast band width is 6 megacycles, which is more than adequate to reproduce the fine detail at the inner ends of the vertical wedges.

The RCA PT-100 theater Tv equipment is capable of accepting and using a signal having a bandwidth of 8 megacycles. When interpreting the test pattern which has just been described, it must be remembered that because of technical limitations many present-day video signals have a bandwidth of only 2 to 4 megacycles. When such a signal is used, the inner ends of the vertical wedges will be blurred. If a video picture signal with a bandwidth of only 2 to 4 megacycles is being reproduced, the finer details are lost.

Electron Beam Cutoff

It is very important that the electron beam in the kinescope can be turned on, or cut off very rapidly, by the incoming video signal, in order to produce sharp vertical edges on images of such objects as buildings, chimneys, etc.

To determine the speed of this control, two vertical edges are provided in the test pattern. These can be seen at the extreme right and left ends of the pattern, between the two outer circles, beyond the ends of the two horizontal wedges, as a pair of blocks. One of these is black, and the adjoining one is white.

At the left of the picture, the electron beam traverses the black block and then the white one. If the electron beam cannot be turned on rapidly enough, the black edge of the block, at the left of the pattern, will extend out into the white block, causing blurring of the black edge.

At the right of the pattern, the electron beam traverses the white block, then the adjoining black one. If the electron beam cannot be turned off rapidly enough, the white edge of the block at the right of the pattern will extend out into the black block, causing blurring of the white edge.

To visualize just how rapidly the electron beam must be turned on or cut off by the video signal, remember that the scanning spot travels across the picture once, and returns to its starting point, 15,750 times each second. Its travel across the screen occurs in approximately 55 millionths of a second!

Scanning Image Speed

On a screen 20 feet wide, the scanning spot image will travel one foot in 55/20, or 2.75, millionths of a second (2.75 micro-seconds). This is a speed of $1,000,000/2.75$, or 363,636 feet per second; or $363.636/5280=68.8$ miles per second, which equals 247,680 miles per hour. At this speed the spot could go

Roundup of Operation, Maintenance Data

These excerpts from a booklet relative to the operation and maintenance of the Peerless Magnarc H-I arclamp introduce a series of similar articles culled from instruction booklets issued by various projection equipment manufacturers. The complete Peerless booklets are available free upon request to the manufacturer.*

I. The Peerless Magnarc H-I Arclamp

IN SETTING up the lamphouse on the projector pedestal, it is important that it be clamped firmly by means of the screws that pass through the pedestal table. The screws which retain the door to the lamphouse rear casting may be discarded, as they are used only for shipping purposes.

The lamphouse door should not be opened until the lamphouse is securely fastened to the projector table, as its weight may cause the lamphouse to over-balance.

All electrical connections between the main terminal block and the carbon holders, etc., are made at the factory. It is necessary, therefore, only to connect the main terminals to the current supply circuit, and that the supply leads for the Trim Alarm be connected to a 6-volt A. C. source. Higher than 6-volts will shorten the life of the lamp bulbs as well as the colored plastic domes that cover them.

For the pilot light inside the lamphouse, one need only enclose the leads in a length of flexible conduit and connect them to a current supply; this supply may often be found at the projector motor switch or at some convenient 110-volt outlet.

Power Supply Requisites

The Peerless Magnarc may be operated with any multiple-type motor generator, or a 110-volt D. C. service, or with a rectifier, providing that the current capacity of the supply unit is sufficient for the current rating of the carbons to be used. Low-voltage motor generators and

* J. E. McAuley Mfg. Co., 554 West Adams St., Chicago 6, Ill.

once around the world in six minutes, or from New York to San Francisco in about 45 seconds!

As was stated in an earlier article, of this series, the RCA PT-100 Tv equipment will reproduce picture elements at the rate of eight million per second, or eight per micro-second. Each picture element may cut off or turn on the electron beam in the projector kinescope. As the spot image is travelling at the rate of one foot in 2.75 micro-seconds, and each picture element occurs in one-eighth of a micro-second, the beam can be turned on or off 8×2.75 , or twenty-two times, in one foot of its travel across the screen. This is approximately one-

rectifiers having satisfactory outputs are available for use with this arc. These lamps may also be operated from higher voltage generators if proper ballast rheostats are inserted in the circuit to reduce the generator output to that required at the arc.

The current range of the Magnarc, together with proper carbon combinations, are shown in Table A. After installation, however, if it be found desirable to change the original carbon sizes to use more or less current, the job may be accomplished very quickly right in the projection room by simply changing two gears as illustrated in detail by drawings in the Magnarc bulletin.

Correct Optical Alignment

Of critical importance in the operation of any arc lamp is correct optical alignment. For this purpose Magnarc makes available rods and discs which, together with a dummy lens barrel, insure practically perfect alignment. The operating distance from the rear surface of the reflector, when measured through the hole in its center, to the projector aperture should be approximately 34 inches.

To obtain this dimension, it may be necessary on certain projectors, using rear shutters, to remove and discard the small metal light cones mounted on the rear half of the rear shutter housing.

When a Magnarc installation is made on projectors having certain types of rear shutters, it will be found that approximately $35\frac{1}{2}$ inches is the shortest working distance that can be obtained

(Continued on next page, Col. 1)

half inch for each picture element, truly a terrific speed!

Obviously, all internal circuit adjustments must be properly made with the use of accurate test equipment—"rule-of-thumb" adjustments are entirely inadequate and would serve only to cause trouble. However, once the equipment has been properly installed and adjusted, and provided with a good input signal, it is capable of producing and projecting on the theater screen a sharp and acceptable picture of an event which may be taking place a thousand miles away.

[The End]

COPPER-COATED H-I CARBONS	AMPERAGE RANGE	ARC VOLTAGE RANGE
7-mm. Positive } 6-mm. Negative (Orotip "C") } 7-mm. Positive } 6-mm. Negative } 8-mm. Positive } 7-mm. Negative }	40-42 42-50 60-70	27-28 33-37 36-40

TABLE A

Carbon combinations, arc voltages and amperages, as compiled by National Carbon Company.

between the reflector vertex and the projector aperture. This is due to the added space that must be provided between the lamphouse front and the rear shutter assembly to allow for the opening of the film gate for threading.

Conventional disc-type rear shutters and their housing generally permit free passage of a cone of light having a circular included angle of 30 2/3 degrees, beginning at an apex point on the optical axis line that is 1 3/32 inches beyond the aperture.

Caution Against Excessive Draught

The Magnarc operates at relatively low arc voltage, and precautions should be taken to guard against air drafts which will disturb the arc. If forced draft is employed in the vent pipes to carry off arc gases, the chimney damper should be installed in the exhaust piping just above the lamphouse chimney base to permit draught regulation to a point where no arc disturbance occurs.

An adjustable friction clutch is provided for the negative carbon feed clutches. The tension of it may be increased or decreased by tightening or loosening the large nut located on the extreme left end of the negative feed clutch shaft. This nut is locked in position by a small set screw. Upon loosening this set screw, the nut may be screwed in or out to tighten or loosen the friction clutch until the desired degree of feeding tension is had.

For ease in rapid arc striking, the tension should not be excessive—only sufficient to insure accurate feed of the negative carbon.

Sudden Current Increase

At infrequent intervals during normal operations a relatively sudden increase of current may register on the ammeter. Generally, the cause can be traced to small cracks in the shell of the positive

carbon or to overloading the carbon combination used. When such cracks occur, they permit a leakage of gas from the crater, rarefying the gas, which condition in turn reduces the normal resistance across the arc.

During such periods the crater will become very shallow and the rim of it will burn to a pronounced rounded edge. The only remedy is to allow the cracked area of the carbon to burn away, or to retrim at the first opportunity.

A good grade of lubricating oil, similar to that used for projectors, should be used on the Magnarc. Oil should be used sparingly, since all parts of the Magnarc are slow-moving, requiring only a few drops of oil in each oil cup—once a week should suffice.

Do not use graphite, or any lubricant containing graphite, on a Magnarc lamp.

British Projection Plagued by Excessive Print Damage

MOTION picture projection is the same the world over, but the British Isles would seem to be having more than a little trouble anent the mutilation of film prints, of a character which has not been too obvious in the U. S., except for the war years, for many a day. As usual, there is the inevitable buck-passing between projectionists and distributors, with the latter following the familiar pattern of being excessively vague as to their inspection routine, etc.

R. H. Cricks, editor of the technical section of the *Ideal Kinema* (London) reports as follows:

"Scratching represents 50% of all damage reported, and perforation damage another 33%. The comparatively small remaining proportion of faults were classified under 19 different headings. Every case of damage was attributed by the renter's (distributor) print manager—necessarily with some degree of uncertainty—to some particular fault.

"Various aspects of projector adjustment or maintenance represented 35%, excluding the classification of 'run off sprockets' (probably also a projector or a reel fault), representing another 9.9%. Dirt or emulsion in the gate represented 18.7% of the faults.

"Faulty threading accounted for

15.3%, and various rewinding faults 17.3%. One figure which I frankly question is 'lack of wax'—0.3%; I should have expected a far higher figure.

'Accidental' and 'Deliberate'?

"With the finest of equipment and the most skilled projectionists, an occasional mishap is bound to occur, yet the figure for 'accidental' was only 0.5%—the same as for a rather unpleasant heading of 'deliberate'. A wide variety of causes accounted for the remaining 2 1/2%.

"One thing is very clear from these figures: nearly two-thirds of all film damage is, in the opinion of the renter's examiners, caused by projectors in faulty condition. The moral is obvious."

It would seem also that British projection equipment is either pretty aged or in a sad state of disrepair.

Importance of DO-97 Stressed by National Theatre Supply

The importance of the new Regulation 4 recently issued by the National Production Authority to authorize the use of a priority rating for business establishments to obtain necessary maintenance, repair and operating supplies is being called to the attention of customers by National Theatre Supply. This rating, known as DO-97, places on a supplier or manufacturer receiving it the obligation to fill such rated orders ahead of non-rated orders.

To alert exhibitors, who may still be unaware of its importance and to make it convenient for them to extend the rating to the supplier, National has prepared a handy yellow-and-black sticker which can be signed and attached to the order. The sticker reads as follows:

NATIONAL THEATRE SUPPLY

"DO-97. Certified
under Regulation 4."

SIGNED

A quantity of these stickers are sent to all customers together with a printed notice pointing out that their use in securing and forwarding the DO-97 certification will eliminate delays and assists manufacturers in continuing to obtain essential raw materials, thus insuring an adequate supply of operating requirements.

Eastman Kodak Earnings Top '50

Eastman Kodak Co. has announced preliminary consolidated sales of approximately \$113 million for the first quarter of 1951 (12 weeks ending March 25). This compares with reported sales of approximately \$84 1/2 million for the corresponding period in 1950. Sales so far this year have continued the upward trend that developed in the last half of 1950.

A Microfilm Edition of IP

All or any part of any issue of IP since Jan., 1950 and in the future is now available on microfilm to libraries, industry and other interested parties as a result of negotiations completed with University Microfilms, 313 No. First St., Ann Arbor, Mich. Complete details relative to this microfilm service is available from the aforementioned organization.

H-I Carbon-Arc Spotlights Enjoying a New Vogue

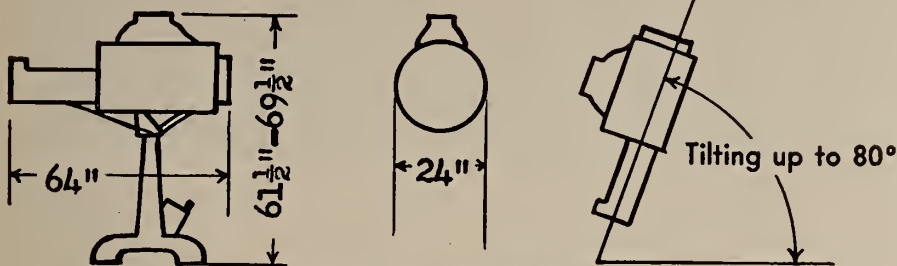

Dimensional characteristics of H-I spotlight under various operating conditions.

THE greatly increased number of large arenas in the U. S. and Canada within the past few years has revived widespread interest in the art of spotlighting—for an art it is. Seating from 6,000 to 12,000 these arenas offer hockey, basketball, boxing, ice shows and many other attractions.

Exactng Requirements

Lighting the performers in an ice show is a prime example of the exacting requirements for efficient spotlighting. Here is a soloist moving around a rink 200 x 70 feet, with 12,000 pairs of eyes focused upon him and following his every move. The whole arena is in semi-darkness (similar to the light level of a modern movie house) and only the powerful

spots cast their beams on the skater.

Under such circumstances, 8 to 14 modern spots are used, located in cages all around the arena about 30 to 50 feet above the rink. Not infrequently the tilt of the unit approaches 70 degrees, at which time the performer comes almost directly underneath the light beam.

The operators of such spotlights are more than a little busy during an ice show. There is a master light plot, of course, but changes are constantly being telephoned by the lighting director. These instructions must be carried out instantly, especially when they have to "hit" or blackout a performer.

They must also follow the intricate, sometimes unpredictable, movements of the skater; they must change the diameter of the spot from a small concentrated headspot to a flood covering a large area

amps D.C. and has a range of throw of from 100 to 400 feet, and the Model ME-5, the vaudeville-type, which pulls 60-85 amps D.C. and covers the 75 to 250 ft. range of throw.

Genarco is an ardent proponent of H-I carbon-arc spots because of the tremendous flood of light that can be placed on an arena. For example, when a performer is in the center of an arena, the throw from 4 of, say, 8 spots would be 100 feet, and the throw of the other 4 spots would be 200 feet. The illumination from a Metro-Lite spot 8 feet in diameter would be 400 foot-candles; the same spot at 100-foot throw would give 100 foot-candles.

Detailed information on the Metro-Lite spotlights is available from Genarco at 36-56 34th St., Long Island City 6, New York.

IA ELECTIONS

LOCAL 162, SAN FRANCISCO, CALIF.

John A. Forde, *pres.*; Orville G. Roush, *1st vice-pres.*; Robert M. Wilson, *2nd vice-pres.*; Raymond Kirkpatrick, *3rd vice-pres.*; Wm. Van Ornum, *4th vice-pres.*; Ernest Langley, *5th vice-pres.*; Thomas J. Kearney, *sec. treas.*; Floyd M. Billingsley, *bus. rep.*; Antone J. Salemi, *sgt.-at-arms*; Roush, Wilson, Kirkpatrick, Van Ornum, and Langley, *exec. board.* (Floyd Billingsley died shortly after election to office.)

LOCAL 165, HOLLYWOOD, CALIF.

Edward Egan, *pres.*; Leo Moore, *vice-pres.*; Howard Edgar, *sec. treas.*; George Flaherty, *bus. rep.*; Al Pullen, Harold Masser, Frank Chaney, Ed Wirling, J. Higgins, *exec. board.*; William Hunger, William Harris, John Linahan, *trustees*; Harold Swanson, Pat Offer, John Schwartz, *exam. board.*; Frank Chaney, E. Egan, L. Moore, G. Flaherty, *del. to CLU*; G. Flaherty, *del. Calif. State Fed. of Labor.*

LOCAL 277, BRIDGEPORT, CONN.

Roland J. McLeod, *pres.*; Frank Toth, *vice-pres.*; Thomas E. Colwell, *rec. sec.*; Leroy Nickerson, *fin. sec.*; Fred Lewis, *treas.*; John A. Martin, *bus. rep.*; John C. Lynch, *sgt.-at-arms*; John Benard, Joseph Cossette, Frank Gorman, Harold Ryckman, *exec. board.*; Leslie C. Blakeslee, James Liburdi, William Towle, Mario Parrelli, Joseph Kaplan, *trustees*; Joseph Cink, James Leverone, McLeod, Nickerson, Benard, *del. CLU*; McLeod and Martin, *del. to all conventions.*

LOCAL 433, ROCK ISLAND, ILL.

Charles C. Derr, *pres.*; Mark M. Maston, *vice-pres.*; Warren Castle, *fin. sec.*; Lloyd Burrs, *treas.*; Fred Parker, *rec. sec. & bus. rep.*; Edward Short, *exec. board.*

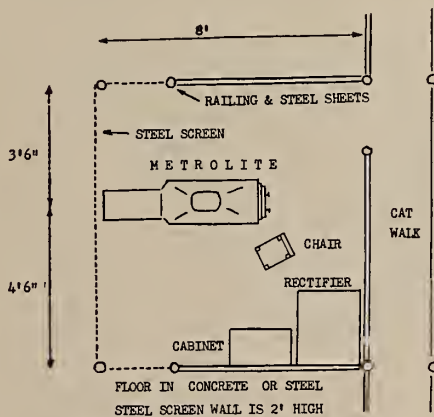
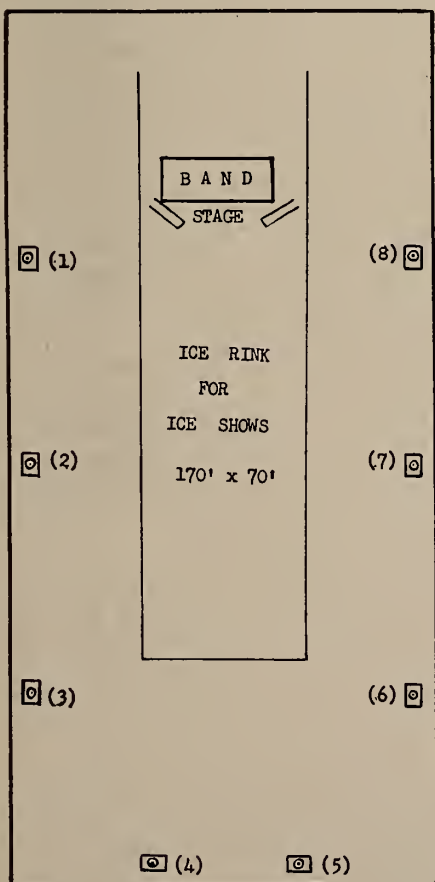

Typical spotlight operating enclosure.

of the rink; they must change the color gelatins, of which they have an extensive supply, and they must utilize with judgment the fading iris.

Performance Depends Upon Design

All these requisites must be considered by the manufacturer of the spot. Easy and quick manipulation, plus a perfectly reliable arc mechanism, are cited as the prime requisites by Genarco, Inc., makers of the Metro-Lite high-intensity, carbon-arc spots. Genarco makes two H-I spots: the Model ME-4 which pulls 125

General arrangement for the use of 8 H-I carbon-arc spotlights in an arena.

Your Very Best Buy

BUY U. S. SAVINGS BONDS



TELECASTS

THEATER Tv got its biggest shot in the arm since its inception during the past month in three developments which indicate that after months of fumbling the motion picture exhibition field finally recognizes the need for drastic action if the economic structure of the industry as presently constituted is to be preserved. These developments, not necessarily in their order of importance, were:

RCA announced that, in addition to the installations already made, new orders for 50 theater Tv systems had been received from 13 exhibitors in states ranging from coast to coast. Work on these jobs will begin immediately.

One of these orders was for 20 units from United Paramount Theaters, which already has five Tv houses. The import of this order lies in the willingness of an experienced operator in theater Tv to plunge so heavily on an extension of its Tv chain.

Wonder of wonders, the Theater Owners of America voted to raise a "war chest" to wage the fight for theater Tv allocations.

The FCC has set Sept. 17 next for hearings looking toward the allocation of frequencies and the promulgation of rules and regulations for theater Tv service. Fifty parties have filed petitions asking FCC to set aside frequencies for this purpose.

The National Collegiate Athletic Assoc. reaffirmed its intention to ban the televising of member college football games for home Tv in favor of cooperation with theater Tv.

200 Tv Theaters This Year?

RCA foresees the early installation of theater Tv equipment in at least 200 locations. There seems to be no doubt that the foresight of RCA in going ahead with full-scale production, even without definite purchase commitments, will permit the delivery of these units despite the growing shortage of certain critical materials which go into their manufacture. Also, the recent reduction in price of almost \$10,000 to the present level of \$15,800 will revive exhibitor interest in the equipment.

The IATSE already has a fairly strong grip on the theater Tv labor setup by reason of its members who have been operating such equipment for several years now, and also because of the joint RCA-IA efforts to instruct a group of leading projectionists representative of

every geographical area in the country.

* * *

Thus the pattern on the exhibition side. But the production unionists were not idle either. Roy Brewer, IA representative on the West Coast, announced that the 14 IA Locals concerned with picture-making will demand participation in producer profits from pictures sold or leased to Tv of from 5 to 10%. This move adheres to the pattern of the musicians (AF of M), who have already inked such deals with film producers.

Already the three "talent" guilds—writers, actors and directors—have earned serious consideration from the producers for their demand of 35% of the Tv revenue from pictures made for the theater, the division of monies to be made on the basis of 1/3 each way. The AF of M deal provided for a 5% cut of such revenue, to go into a welfare fund, *in addition to* the proviso that the musical track of each film had to be rescored by the same number of musicians originally employed and taking the same time it took to do the job originally. Obviously, this is purely and simply a make-work arrangement.

Sale of Tv Prints

Meanwhile, United Paramount Theaters is missing no bets with its intermediate Tv system, which takes programs off the air and records them on film. Events of prime national importance are rushed into print form and sold to *both* theaters and Tv stations. Reportedly, the recent MacArthur speech before Congress was leased for \$1000 per print.

There is no doubt in informed circles that a circuit of Tv theaters could give the Tv broadcasters plenty of headaches. For example, last Fall the cost to the Univ. of Michigan for camera crews and the announcer for one game ran to \$882. With 10 Tv theaters joining in a circuit for the same game, the cost would be only \$88. And how about the profit angle?

Yea, verily, the theater Tv pot is boiling, and it would seem that the extent to which the chicken will be cooked to a point where it is edible would depend entirely on the courage, energy and resourcefulness of the exhibition field over the next few months.

* * *

Kinescope Recording a 'Must'

Kinescope recording "has withstood the test of time and trial by ordeal" to the

point where "it may now don long pants and take its place beside its big brother, film distribution, to render a real service on a practical businesslike basis." So reported Frank C. Lepore, of NBC, at the recent SMPTE convention.

Lepore said that "kinescope recordings make possible national Tv networks guaranteeing a bright future for the newest and most dynamic medium of advertising and communication yet devised by man."

It was contended by Lepore that "despite all the gloomy talk about the extinction of kinescope recording when all stations have been interconnected by cable sometime in the future, the difference in time zones and delayed broadcasting three or four hours after the live show for the benefit of audiences in far places will continue to make kinescope recording or some modification of same a practical reality for some time to come."

* * *

Tv Socks Its Maw—Radio

Not all the woes passed along by the mushroom growth of television have been visited upon the motion picture industry. Radio, which spawned Tv, now finds itself a victim of its own *enfant terrible*.

N.B.C. is planning a reduction of its network radio time charges to meet a similar competitive move announced recently by C.B.S. The latter chain, the first among the four major radio networks to announce a cut, said its reduction of 10 to 15% would become effective on July 1.

The rate cutting, it is believed, comes as a result of inroads made on radio audiences by Tv. National advertisers, representing most all of radio's major sponsors, have sought a radio-rate reduction ever since Tv came into competition with the older medium.

While A.B.C. has announced no rate reductions, a spokesman said that the chain intends to "maintain its competitive rate advantage" among three of the major networks. Mutual has reserved comment so far.

The rate cut by N.B.C. is part of a three-way economy move now being formulated, including a reduction in the number of staff radio personnel. It is understood that all N.B.C. radio departments will be affected, but the number of personnel dismissed is not known.

In the case of sustaining radio pro-

grams, which have no sponsors, N.B.C. is planning less costly shows for next fall. What radio budget cuts might come before then cannot be foreseen.

NEWS PROJECTIONS

WAGE STABILIZATION BOARD has announced that motion picture "talent" will not be held to the 10% limitation on wage increases. Affected are players, producers, directors, writers, composers, musicians, art directors, wardrobe designers, cameramen and assistants, sound engineers, and film editors. . . . A flat per-admission rental charge for films for competitive theaters is advocated by Allied exhibitors. . . . Terrific print shortage, with film being "run to death" in successive engagements without proper exchange inspection, is attributed to distributor economy move rather than to any stock shortage. . . . Group of Tv film producers assert that video will be purchasing \$240 million worth of film annually by 1954. . . . All-out use of color film, nothing less than 100%, is the "salvation of the motion picture industry." Who said it? Why, Dr. H. T. Kalmus, president of Technicolor.

Growing suspicion in film circles that surveys made by advertising agencies and other groups purporting to show the "decline" of motion picture interest are "plants" in behalf of their big-time Tv clients. . . . General Federation of Women's Clubs estimates that there are no less than 12 "good" films worth seeing each month. . . . Princess Theater, Minneapolis, offers 3 wrestling bouts and a feature film at \$1 for adults and 50c for children. First such shows O.K. at box-office. . . . "Arty" films, mostly foreign-made, going great guns at "class" small theaters. . . . Tv programs continue to smear movies—in theaters, that is, because Tv would die without film, even of the 10-to-15-year vintage. . . . RKO Theaters in N. Y. City have renewed contract with NBC for the advertising of their film programs.

Bingo games, a tough competitor for theaters, is having a bit of rough going because of rising sentiment against any form of "gambling." . . . Paramount's releases for the balance of this year represent a record investment in production. . . . First-quarter craft labor employment in West Coast studios this year was 14,400, a gain of 1700 over same period last year. . . . Miami crusador's attempt to have all film theaters closed on Sundays flopped, the decision being that the exhibitor is not a "merchant." . . . Some exhibitors advocating a lower mid-week admission price as a spur to attendance.



Your patrons will notice the difference! Super Snaplites give you Sharper Pictures, More Illumination, Greater Contrast and Definition.

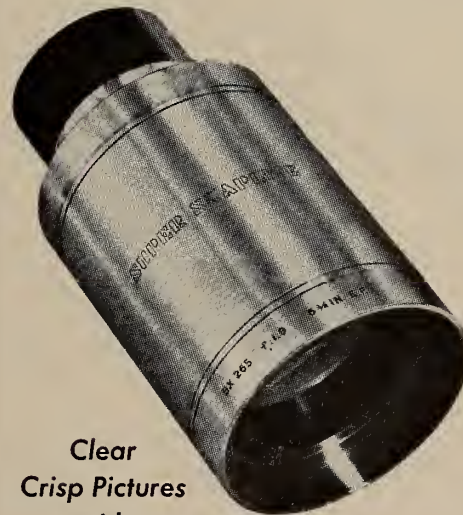

Clear
Crisp Pictures
with
SUPER SNAPLITE
f/1.9
PROJECTION LENSES

For the Best in Projection use Super Snaplites . . . the only Projection Lenses to give you a true speed of f/1.9 in every focal length up to 7 inches.

Ask for Bulletins
207 and 209

KOLLMORGEN

2 Franklin Avenue
Brooklyn 11, New York

Optical



CORPORATION

"YOU GET MORE LIGHT WITH SUPER SNAPLITE"

SMPTE 69th CONVENTION

(Continued from page 10)

to leave the hands of a serving maid on the screen and float out before the audience to a position just a few inches before the eyes of each spectator.

The stereoscopic effects are achieved, first by filming the scene from two different displaced positions, corresponding to the displacement of the eyes; next by projecting the film through a polaroid filter which polarizes alternate still pic-

tures in different directions; and finally by viewing the pictures through polaroid viewing glasses, with a different polarization for each lens corresponding to that of the alternate frames of the picture.

Screen Brightness Sub-Standard

Screen brightness lower than the recommended standards was found in nearly one-fourth of 88 indoor theaters covered by a progress report presented by the Screen Brightness Committee.

Constituting findings to date in a sur-

vey of 100 representative indoor theaters begun by the committee last year, they reported that screen brightness ranged from 3.4 to 53 foot-lamberts, with approximately one-fourth below and one-half within the ASA range. Two theaters equipped with highly-directional "silver" screens had a central maximum screen brightness in the range of 30 to 53 foot-lamberts.

With respect to distribution of illumination over the screen, expressed as a ratio of side-to-center intensity of incidental illumination, the committee reported that the side distribution ranged from 40 to 94% for the indoor theaters, with almost two-thirds of the projectors falling between 60 and 80%.

Poor Over-All Average

Only about 40% of the indoor theaters had reflectivities in the 70-to-80-per cent range typical of the matte white screen in good condition, the report stated. About 25% of the screens were a little below this range, and another 20% were substantially lower, ranging down to 44%.

"It is expected," the report concluded, "that the results of the survey, when completed, will form the basis of a Committee recommendation for improvement of projection practice in theaters." In the meantime, it stated, better attention to operation and maintenance could reduce the wide range of screen brightness and eliminate many of the highly non-uniform distributions of illumination.

Theater Tv Safety Program

Special safety regulations covering the installation and operation of theater television systems are being discussed in Chicago by the city's Board of Examiners of Motion Picture Machine Operators the Society was told by Samuel R. Todd, a member of the board. Such regulations, if and when adopted, will be administered by the same board, which has jurisdiction over all motion picture projector operation in the city, including such activities in television studios as well as in theaters, Mr. Todd said.

Although new problems, apart from those involved in film presentation, have been presented by the introduction of theater television, he said, presently available direct projection theater television equipment is "very well designed from the viewpoint of having adequate safety disconnect switches at all points where dangerous electrical potentials may be encountered."

Keep Safety Circuits Intact

It is extremely important, he said, that all of these safety circuits be kept intact at all times, and that no unauthorized modifications be made.

In the case of theater television systems of the so-called storage type, employing motion picture film, he said, a

NATIONAL HAS EVERYTHING
FOR THE PROJECTION ROOM

Get it
from
National!

NATIONAL
THEATRE SUPPLY

Division of National • Simplex • Bludworth, Inc.

29 BRANCHES • COAST TO COAST

"World's Most Powerful Spotlight"

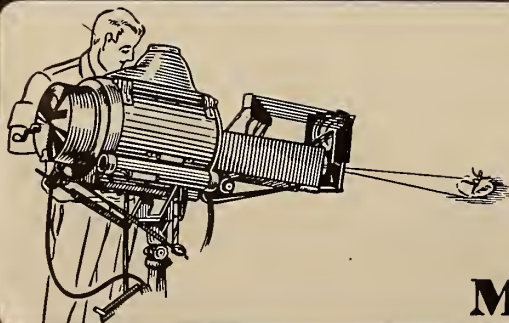

The METRO-LITE high-intensity carbon arc spotlight comes in two models:—

- ★ MODEL ME 4 125 Amps D.C.
100 ft. to 400 ft. throw.
- ★ MODEL ME 5 "Vaudeville"
60 to 85 Amps D.C.
75 ft. to 250 ft. throw.

METRO-LITE

Literature available on both units upon request to
GENARCO, Inc. 36-56 b 34th St., Long Island City 6, N. Y.

properly ventilated room with fireproof construction is required for the television receiver, the 35-mm camera, and the developing and drying equipment.

Mr. Todd reported that regulations governing the use of 16-mm projection equipment in all places except private homes have just been completed by the Chicago Board of Examiners, and will require that only licensed operators be used for such presentations hereafter, the same as in the case of 35-mm projection.

Abstracts of some of the papers presented at the convention are appended hereto:

THE LUMINANCE DISCRIMINATION OF THE HUMAN EYE

E. M. Lowry

Eastman Kodak Co., Rochester, N. Y.

The effect of the luminance to which the eye is adapted on its ability to discriminate differences in luminance, and the effect of the visual angle on this ocular function are discussed. Luminance discrimination depends on whether the observer's attention is fixed on a highlight or shadow region as is shown by data on threshold luminance in scenes in which the luminance varies widely.

INFLUENCE OF COLOR OF SURROUND ON HUE AND SATURATION

David L. MacAdam

Eastman Kodak Co., Rochester, N. Y.

The appearance of a color picture depends on the quality of light in its surroundings. The most obvious effect is a shift of the apparent balance of the picture. Variations of the criterion for white responsible for this shift, and equally important changes in perceived hues caused by adaptation to various surrounding colors, have been determined by color measurements and specified in chromaticity diagrams.

QUALITY CONTROL DEPARTMENT OF A MEDIUM SIZE FILM LABORATORY

Edgar E. Berger

Du-Art Film Laboratories, N. Y. City

Procedures are described for establishing and maintaining quality standards. Methods of obtaining developing solution constancy are detailed. The mechanics of organizing and running printing machine uniformity tests, negative sound and negative picture tests, emulsion tests and other operational control matters are discussed.

SAFETY REQUIREMENTS IN PROJECTION ROOMS AND TV STUDIOS

Samuel R. Todd

Board of Examiners, City of Chicago

Nitrate film has imposed special requirements on projection room design for many years. The advent of 35-mm safety film may change some of these, and this possibility is discussed. The increasing use of films, both nitrate and safety types, in television studio operations calls for similar precautions and the presence of considerable electronic equipment adds to the normal hazards. These hazards and certain others peculiar to live

Protect the HEART of your theatre with RCA Service...

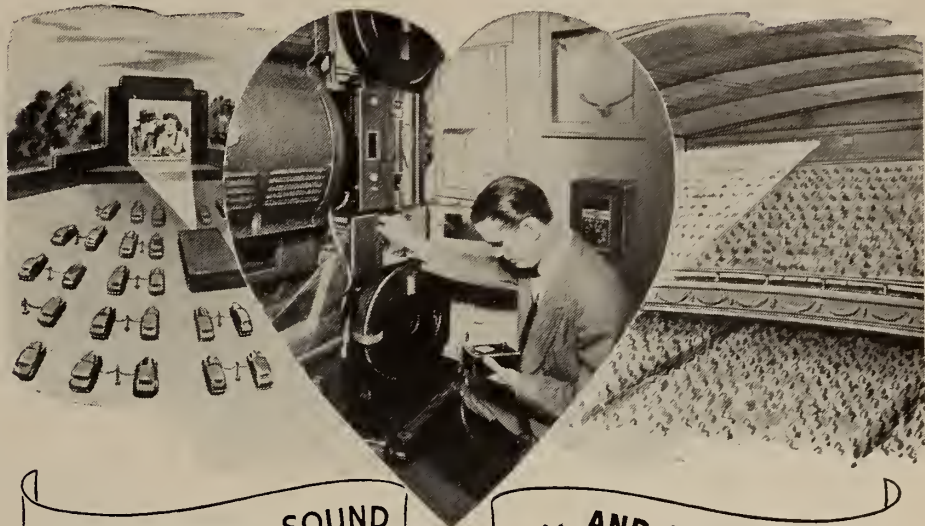

PROJECTION...SOUND

...AND RCA SERVICE

The possible scarcity of new equipment makes it doubly important today that you safeguard and conserve your projection room equipment—the heart of your theatre. So, for top performance security, be sure your theatre is protected with an RCA Comprehensive Parts and Repair Plan.

It costs so little to protect so much

The advantages of RCA Service are yours at a cost so low, a few admissions daily pay for it. Write for FREE folder—“Performance Security.”



RCA Service and Parts Plans cover all makes and types of theatre sound equipment, as well as motion picture projectors and accessory units.

RCA Service averts breakdowns and assures you of the ultimate in performance security. But if a theatre needs emergency service it is available 24 hours every day.

For drive-in theatres... in addition to a preventive maintenance plan for projection equipment... RCA has a replacement and repair plan on RCA In-car Speakers and Junction Boxes.



RCA SERVICE COMPANY, INC.

**A RADIO CORPORATION of AMERICA SUBSIDIARY
CAMDEN, NEW JERSEY**

CLAYTON BALL-BEARING EVEN TENSION TAKE-UPS

For all projectors and sound equipments

All take-ups wind film on 2, 4 and 5 inch hub reels.

Silent Chain Drives

THE CLAYTON REWINDER

For perfect rewinding on 2000-foot reels.

CLAYTON PRODUCTS CO.

31-45 Tibbett Avenue

New York 63, N. Y.

program presentations are discussed. Safety problems involved in the installation and operation of high voltage television equipment in theaters are outlined.

PRODUCING ELECTRONIC MOVIES

E. Arthur Hungerford, Jr.
General Precision Labs., Pleasantville, N.Y.

Described are the various production techniques for producing high-quality video recordings on a closed-loop basis. Areas to be covered include dramatic, educational, news and sports, and commercials. Accent is on methods to achieve maximum speed of production. Examples of attainable quality are shown.

PHOTOMETRIC FACTORS IN THE DESIGN OF MOTION PICTURE AUDITORIUMS

H. L. Logan
Holophane Co., Inc., N. Y. City

The photometric factors involved in designing the visual environment in a motion picture theater so as to promote the comfort, enjoyment and safety of the audience are discussed.

SURROUND BRIGHTNESS: KEY FACTOR IN VIEWING PROJECTED PICTURES

Sylvester K. Guth
General Electric Co., Cleveland, Ohio
The problem of providing general lighting

in areas where projected pictures are viewed and the effects of such lighting upon the projected pictures are analyzed. New data are presented which illustrate the effect of surround brightness on visibility and on viewing comfort. These data provide a simple basis for establishing surround brightnesses in auditoriums for optimum viewing.

NEW APPROACHES BY RELATING FILM PRODUCTION TECHNIQUES TO EXHIBITION

Benjamin Schlanger and
William A. Hoffberg

A larger screen, camera angles, factors of psychophysical vision and auditorium viewing are considered relative to the development of more flexible screen cinematography. Screen masking, surround and auditorium environment are also considered.

NEW SYSTEM FOR MEASURING AND SPECIFYING IMAGE DEFINITION

Otto H. Schade
RCA Victor Division, Harrison, N. J.

The capability of an image-forming device to reproduce fine detail is specified by the characteristics of its point image. Because it is difficult or in some cases impossible to measure directly the point image formed by a lens, a photographic film or an electronic system, the diameter of an equivalent point image of standard shape is evaluated from measurements of the sine-wave response of the device.

The theory substantiating this equivalence, as well as simple practical methods of measuring the sine-wave response of lenses and film, was discussed and illustrated by slides.

NEW PROCESSING MACHINE FILM SPOOL FOR USE WITH 35- OR 16-MM FILM

F. L. Bray
Du-Art Film Laboratories, N. Y. City

After a number of experiments to find the best sprocket and spool combination for 16-mm or 35-mm film, it was decided to use a radically new type of spool distinguished by a tapered profile. The advantages of this design, as applied to sprocket- and friction-drive machines, are given.

16-MM PROJECTION FOR STORAGE OPERATION WITH TV CAMERAS

E. C. Fritts
Eastman Kodak Co., Rochester, N. Y.

A projector previously described for use in professional motion pictures is adapted for television use. The pull-down angle of the intermittent sprocket permits operation on a storage basis with the pull-down action at the normal rate of 24 frames per second. The shutter, on a separate motor, can be run without the film mechanism for single-frame projection.

Separate optical systems are provided for iconoscope and image-orthicon tubes with lenses especially corrected for the magnifi-

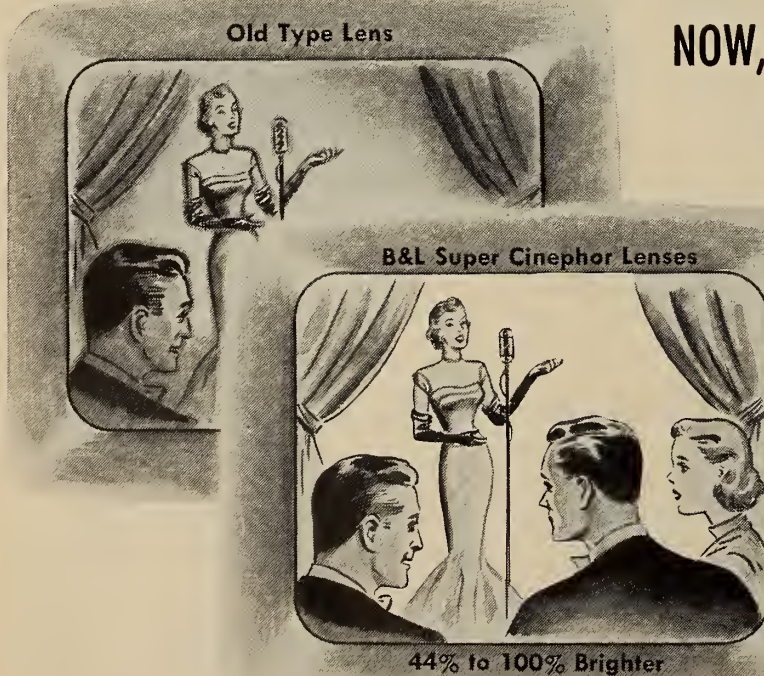

NOW, more than ever

HOLD your patronage with the

WORLD'S FINEST SCREEN IMAGE!

Replace NOW . . . for steady patronage . . . steady profits . . . with B&L Super Cinephor Lenses

Get large, vivid screen images! They're your best competitive advantage over any other type of entertainment. Your patrons will keep coming back to see the sharp, brilliant images of today's fine films . . . the edge-to-edge contrast and definition . . . the superb image quality . . . that you get with B&L lenses.



Write for complete information to Bausch & Lomb Optical Co.,
616-5 St. Paul Street, Rochester 2, N.Y.



Bausch & Lomb

Super Cinephor Projection Lenses

cation. The preamplifier is equalized for uniform response to 7000 cycles per second. Low-pass filters offer a choice of cut-off frequency.

CONTINUOUS PROCESSING MACHINE FOR WIDE FILM

H. E. Hewston and Carlos H. Elmer
U. S. Naval Ordnance Test Station,
China Lake, California

A new continuous processing machine for



• The NEW, improved, positive method of permanently patching all types and makes of film—8mm., 16mm., 35mm., Tru-Kolor, Technicolor, Kodachrome, Nitrate and Safety Film.



Used and endorsed by Projectionists in countless theaters.

specifically for lasting Patches.

ESSANNAY ELECTRIC MANUFACTURING CO.
1438 North Clark Street Chicago 10, Illinois

IMPERIAL STEDYPOWER

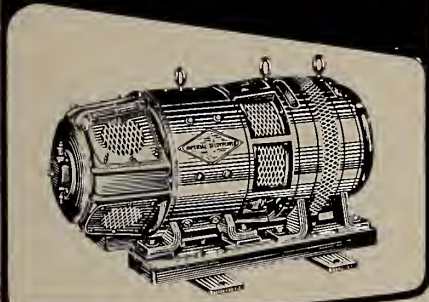

"THE POWER BEHIND THE SCREEN"

SPECIAL MOTOR GENERATORS FOR EVERY ARC PROJECTION

- Proven "Trouble Free" Performance
- Quality Built, Quiet Operation
- "Rubber in Shear" Mounted Vibration Free
- Long Life, Low Maintenance

Distributed by Independent Theatre Supply Dealers or Write to:



wide film is described. This machine carries the principles of motion picture film processing into the field of processing black-and-white film ranging in width from 70-mm to 12 inches. Details of design and operation are outlined.

NEW TELEVISION RECORDING CAMERA

Frank N. Gillette and R. A. White
General Precision Labs., Pleasantville, N.Y.

The camera described has been designed specifically for video recording purposes. To accomplish intermittent film pulldown within the short space of time available, a multiple skip claw movement is utilized. The usual mechanical shutter is eliminated, by the use of an electronic shutter.

In order to obtain the necessary film stability at the aperture, a vacuum-operated film gate is utilized, which permits the camera to be operated for rather long uninterrupted periods of time. Provision is made within the camera for the simultaneous recording of sound, at standard spacing for correct sound synchronization.

INDEPENDENT FRAME: RATIONALIZING PRODUCTION

Lt. Col. G. R. Stevens, OBE
Television Film Prod., Ltd., London, England

To reduce the cost and improve the efficiency of motion picture production, the independent frame technique, sponsored by the J. Arthur Rank Organization of Great Britain, aims at a flow system of production. This method, which has had marked success in a series of experimental films, now is being developed for use with television cameras and for remote direction and editing.

RANDOM NOISE REQUIREMENTS FOR THEATER TELEVISION

Pierre Mertz
Bell Telephone Laboratories

Provisional evaluation of permissible random noise for theater television is considered from several sources of information. For broadcast television a frequency weighting, and limit on weighted noise power, have been used. The finer picture detail of theater television presumes a lower random noise. Changes in weighting curve are discussed. A limit figure of noise is suggested, comparable to graininess effects in motion pictures, but slightly more severe than published performance on camera tubes.

COMPARISONS OF CURRENT PROJECTION SYSTEMS FOR INDOOR AND DRIVE-IN THEATERS

H. J. Benham
RCA Victor Division, Camden, N. J.

Motion picture projection systems are available today in several combinations which meet the requirements for screen brightness recommended by the Screen Brightness Committee of the SMPTE for practically all types and sizes of indoor theaters. Standards for screen brightness and maximum viewing distances have not been established for drive-in theaters.

It is generally recognized that most large drive-in theaters operate with inadequate



Stop

BEING A CARBON WASTER

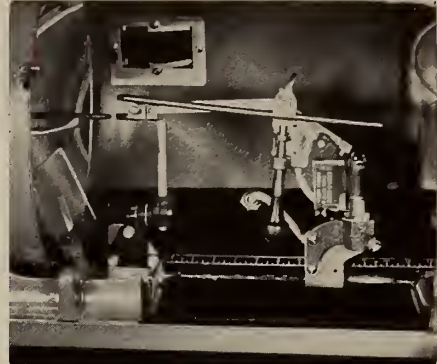

THE CRON-O-MATIC Fully Automatic CARBON SAVER

uses up stubs of all lengths. No preparation required. Simply insert in the holder.

In no way interferes with the regular operation of the lamp.

Cuts Carbon Costs 25%

Conserves your supply of carbons with the heavier copper coating.

Adaptable to Ashcraft "D", Brenkert-Enarc, Peerless Magnarc and Strong Mogul lamps.

Only \$52.50. Quickly pays for itself . . . then goes on to make money for you.

SOLD BY

ALBANY, N. Y.	National Theatre Sup.	DENVER, COLO.	National Theatre Sup.
ATLANTA, GA.	Southeastern Theatre Equipment Co.	JACKSONVILLE, FLA.	Southeastern Theatre Equipment Co.
BOSTON, MASS.	Joe Cifre, Inc.	KANSAS CITY, MO.	Shreve Theatre Supply
BUFFALO, N. Y.	Eastern Theatre Supply Co., Inc.	Stebbins Theatre Equipment	MEMPHIS, TENN.
CHARLESTON, W. VA.	Charleston Theatre Supply	NEW ORLEANS, LA.	Monarch Theatre Supply Co., Inc.
CHARLOTTE, N. C.	Southeastern Theatre Equipment Co.	Southeastern Theatre Equipment Co.	National Theatre Sup.
CINCINNATI, OHIO	Midwest Theatre Supply Co.	PITTSBURGH, PA.	Atlas Theatre Supply
DALLAS, TEX.	Hardin Theatre Supply Co.	SALT LAKE CITY, UTAH	Service Theatre Supply Co.
Southwestern Theatre Equipment Co.	SAN FRANCISCO, CAL.	Western Theatre Sup.	

If your theatre equipment dealer cannot supply you, order direct.

PAYNE PRODUCTS COMPANY Cron-O-Matic Division

2454 W. Stadium Blvd., Ann Arbor, Mich.

- () Please send free literature on Cron-O-Matic Carbon Saver.
() Please ship Cron-O-Matic Carbon Saver, { } C.O.D., including postage.
{ } Remittance herewith.

NAME
THEATRE
STREET
CITY & STATE

Dealer Inquiries Invited

screen illumination, yet the amount of light produced by their projection system is more than can be used without danger of film damage unless devices are used for cooling the film or removing the heat from the light beam.

NEW 35-MM TV RECORDING CAMERA

John Kiel

Producers Service Corp., Burbank, Calif.

This paper describes a new 35-mm television recording camera, with particular em-

phasis on the mechanical design features related to the picture-splice. Since certain film phenomena, phosphor persistence, and angular shutter size are directly related to the perfection of splice, these factors and their particular effects are also discussed.

3-DIMENSIONAL MOTION PICTURE APPLICATIONS

R. V. Bernier, Maj., USAF

Wright-Patterson AFB, Dayton, Ohio

Methods of taking and projecting 16-mm

high-speed, normal speed, and time-lapse stereoscopic motion pictures of the alternate-frame type are described. Included is a description of a newly patented polaroid method for right and left picture selection as used in the Eastman High-Speed Camera and as used in projection.

Other mechanical stereo systems as used in normal and time-lapse cinematography are discussed. The paper will be supplemented by the showing of a stereo film using a single 16-mm projector equipped with a synchronized drum polarizer in front of the lens and a Morgana-type shuttle mechanism.

PHOTOELECTRIC METHOD FOR EVALUATING STEADINESS OF MOTION PICTURE FILM IMAGES

R. W. Lavender

AnSCO Div., General Aniline & Film Corp.

Comparative data on the steadiness of motion picture film images are generally obtained qualitatively by experienced viewers. Recently, problems encountered in evaluating the relative merits of several proposals for a single-perforation standard for 35-mm motion picture film necessitated the development of an instrument for obtaining specific quantitative steadiness data.

The instrument described, which utilizes variable-area photoelectric recording techniques, provides quantitative steadiness data of the motion picture image relative to the screen and/or perforation. When used in conjunction with a special test screen, the film being tested may be viewed and its steadiness recorded simultaneously.

AUDITORY PERSPECTIVE

H. G. Kobrak, MD

University of Chicago

The principles of auditory localization as related to stereo sound reproduction are discussed. The human head carries on its lateral aspects two biological sound receivers. The position of the receivers and the role of the skull in the sound field are discussed.

The attributes of the acoustic signal (intensity, phase, time) relevant in sound localization are described. The factors of experience and training as well as the stereo performance of deafened ears are analyzed.

REPORT ON SCREEN BRIGHTNESS COMMITTEE THEATER SURVEY

W. W. Lozier

Chairman, Screen Brightness Committee

The Screen Brightness Committee has undertaken a survey of screen brightness in 100 representative motion picture theaters in this country. Progress to date will be reported.

MODIFIED NEGATIVE PERFORATION PROPOSED AS A SINGLE STANDARD FOR 35-MM MOTION PICTURE FILM

W. G. Hill

General Aniline & Film Corp.

The existence of two or more perforation shapes for 35-mm films has, for many years, been considered undesirable. Registration problems are minimized if negative perforations are used throughout; experience, however, has shown that projection life is short.

ANSWER TO YOUR TECHNICAL PROBLEMS...

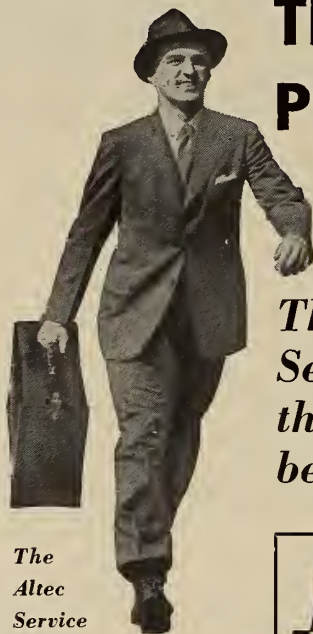

The Altec Service Man

The Altec Service Man and the organization behind him



161 Sixth Avenue, New York 13, N. Y.

PROTECTING THE THEATRE - FIRST PLACE IN ENTERTAINMENT

NEVER HAS Economy BEEN SO ESSENTIAL AS NOW!

THERE IS A LORRAINE CARBON TAILORED FOR YOUR SPECIFIC PROJECTION REQUIREMENT

Send necessary projection equipment data to guide us in recommending the Lorraine Carbons that will do your theatre or drive-in projection job better and More Economically.

SLOW BURNING SAVINGS IN POWER CONSUMPTION SAVINGS IN MAINTENANCE

ECONOMIZE

WITH *Lorraine Carbons*

Lorraine CARBONS, INC., BOONTON, N. J.

The modified negative perforation, which fillets at the corners, has improved resistance to tear while preserving the general negative form corresponding to conventional piloting means.

THE PRACTICAL SOLUTION TO THE SCREEN LIGHT DISTRIBUTION PROBLEM

Charles R. Underhill, Jr.

RCA Victor Division, Camden, N. J.

Described is a vinylite plastic screen which has the center area compensated for by a greater number of perforations than the edge area.

TEMPERATURE-SENSITIVE PHOSPHORS FOR EVALUATING AIR JETS TO COOL FILM

F. J. Kolb, Jr., and F. Urbach

Eastman Kodak Co., Rochester, N. Y.

Temperature-sensitive phosphors, designed to show a variation in luminescent intensity—under ultra-violet excitation—with temperature of the phosphor, may be applied directly to a piece of film that can be examined in a projector gate.

When this coated film is heated by radiant energy (comparable to the radiant beam used in projection, but diminished in intensity sufficiently to permit the coated film to remain stationary in the gate) temperature differences across the film become visible immediately as differences in the intensity of luminescence. Cooling patterns of various

air jets can be demonstrated, and relative efficiencies of several designs can be compared.

MEASURING TOTAL LIGHT OUTPUT AT THE PROJECTION LENS

G. Gagliardi, Warner Bros. Theaters
A. T. Williams, Weston Electrical Instr. Co.

This instrument utilizes an integrating sphere and a Weston Photosensitive meter, used in conjunction with a specially designed film aperture plate which is inserted at the projector gate with holes perforated to give a total light reduction of ten to one. Other plates are available to simulate measurement in the prescribed screen locations in accordance with Screen Brightness Committee Recommendations. Accuracy of this system is indicated to be within $\pm 5\%$ of direct screen measurements.

THE MAGIC OF COLOR

(Continued from page 15)

of chaos. The Munsell System blithely ignores the trichromatic character of human color vision and assumes five primary colors! Naturally, such a system must be considered as a makeshift, at best.

An experimental hue scale may be made by dividing a circle into a number of equal sectors and coloring the sectors with appropriate hues in normal order. A circle having 6 sectors colored, consecutively, red, orange, yellow, green, blue, purple, and back to red constitutes a 6-hue scale. Now the question arises: is this 6-hue scale a useful one for the many widely different applications to which such scales are applied? Perhaps

we decide that the number of hues is too small, so we subdivide it to form a 12-hue scale as follows: red, red-orange, orange, orange-yellow, yellow, etc., all the way around. Another division of the sectors may be considered necessary to give a 24-hue scale, and again to give a 48-hue scale, etc.

But as the number of hues increases

ON THE NEW YORK SKYLINE...

The Hotel HOLLAND
on 42nd St.
Just West of Times Square

400 airy rooms with private Baths and Showers. Coffee Shop and Bar. Attractive Roof Garden. Free radio. Television—Swimming Pool.

21-Story Fireproof Building
351 West 42nd St.,
New York 18, N. Y.
Circle 6-0700

FROM \$3.50 SINGLE \$5.00 DOUBLE



EFFICIENT • DEPENDABLE

RECTIFIERS

for Every Type Projection Lamp



2-Tube
4-Tube
6-Tube
Single and Three Phase Models for

- Rotating Feed Angular Trim High Intensity
- Copper Coated Coaxial High Intensity

- 1 K.W. High Intensity
- Low Intensity

Smooth Output Current • Long Life
Low Operating Temperature
Flexibility in Control

Write today for literature or free demonstration.

THE STRONG ELECTRIC CORP.

31 CITY PARK AVENUE
TOLEDO 2, OHIO

PROJECTION LAMPS • RECTIFIERS
SPOTLIGHTS • REFLECTORS

ONLY Century PROJECTORS HAVE EVERYTHING



4-inch diam. lens mount

Water-cooled apertures

Oil-less Bearings

CENTURY'S high-efficiency projector with the NEW 4-inch diam. lens provides pictures of increased brightness and appeal—for even the largest drive-in screens.

CENTURY'S water-cooled aperture gives as much light with a 90 ampere arc as other projectors using a 180 ampere arc and heat filters!—Reduce power cost—Get sharper pictures—Save film.

CENTURY'S sealed, oil-less bearings and glass-hard gears reduce maintenance costs. No oil sprays or baths to mess up film or projection room.

You can SEE and HEAR the difference!

CENTURY PROJECTION AND SOUND SYSTEMS
See your dealer or write for information

CENTURY PROJECTOR CORPORATION
New York, N. Y.



it becomes increasingly evident that something is radically wrong. The hues change too abruptly both in the yellow-green and in the purple-red sextants. Furthermore, the colors of opposite sectors are not always complementary, thus reducing the usefulness of the scale.

True orange and true blue are exactly complementary, but true red and true green are not quite complementary, and true yellow and true purple are far from being complementary. Our original 6-hue scale (as well as all others derived from it) is clearly neither balanced nor equitempered. We may as well throw the whole thing away and start all over again on a different basis.

An Equitempered Hue Scale

The position of hues in the spectrum is of no help in devising an equitempered hue scale. A glance at Fig. 1 shows that hues change rather rapidly in the yellow and blue regions, while the orange, and especially the green, regions are rather attenuated. In order to determine equal sensation-unit intervals we must experiment with a large number of observers.

If such experiments are made, and the results jotted down on a diagram of the normal spectrum, lines spaced similarly to those at the top of the spectrum-band in Fig 1 are obtained. This is data of fundamental importance.

Now, any useful hue scale should be based fundamentally on the three primaries and their complementaries. The hues which most observers call "true" red, orange, yellow, green, blue, and purple should also be included, as these are the most commonly used colors. Other hues will have to be included in order to maintain equal sensation intervals between adjoining hues; and any small irregularities which are present in the data obtained from observers will have to be smoothed out to insure each hue-sector being complementary to the sector directly opposite.

All this can be done; and it will be found that a minimum of 48 hues can be used. Fig. 3 is such an equitempered scale.

A 48-Hue Color Chart

IP's 48-hue color chart has as its starting point, not red as in other color systems, but a strongly yellowish green called *xanth*. This will be found at the very top of the chart. The reason for this choice is that all the hues from chartreuse (moderately greenish yellow) to chrysin (yellow-green) are generally the most unpopular colors in the entire scheme of hues! And *xanth*, the first hue of the green group, the "sickliest" of all yellow-greens, is flanked by *mascagna* and *chlorise*, colors almost as unpopular as itself. A "break" in this region accordingly occasions far less inconvenience

to color technologists than a break in the red region.

The 48 hues are given one-word names, not numbers, for identification. Familiar hue names have been retained—the few coined names present are intended to be suggestive of the hues they represent. The wavelengths (millimicrons) of the hues, and also of the dividing lines between the six main color families, are specified. The names of the primaries are printed in capitals; those of secondaries are underlined.

The X in the center of the chart assists in locating the opposite, or complementary, of each hue.

[To be Continued]

B. & K. Chicago Theaters' Net

Balaban & Katz Corp., Chicago theater chain, in 1950 had net earnings of \$2,175,354, or \$8.28 a common share, compared with \$2,805,000 or \$10.68 a share in 1949. The company opined that it had now felt the full impact of Tv, although there is "cautious optimism" that good pictures will draw well despite Tv.

The company reported that its own Tv station in Chicago, WBKB, was operated at a profit during 1950, as against a "considerable loss" in 1949.

United Paramount Earnings

Net profit of United Paramount Theatres, Inc., for the fiscal year ending Dec. 30, 1950, the first full year of operation since the divorcement from Para-

mount Pictures, was \$12,351,000. This included dividends from affiliated companies of \$1,420,000, and \$209,000 of undistributed earnings of partly owned, non-consolidated subsidiaries.

During the year the company ended joint interests in 457 theatres, and disposed of all interest in approximately 241. The latter were jointly owned at the time of the consent judgment in the anti-trust case. The company paid \$12,000,000 in cash for the 50% interest of its co-owners in Interstate Circuit, Inc., and Texas Consolidated Theatres, Inc., operators of 160 theatres in Texas and New Mexico.

Estimated consolidated earnings for the first quarter in 1951 were reported at \$2,791,000.

Lenses in "Reasonable Quantities" in 1951—Kollmorgen

Projection lenses will be available in "reasonable quantities" during 1951, despite the NPA controls on such essential material as aluminum, which is used in making lens mounts. This is the opinion of Kollmorgen Optical Co., makers of the Snaplite series of lenses.

The firm warned that "delays in shipments due to priority orders can be expected in 1951" and urged that those in the trade "anticipate their requirements as much as possible." It said that in ordering lenses in 1951 "care should be taken to determine the exact focal length required to eliminate delays due to not ordering the correct size."

How Many?

Was this copy dog-eared when it came to you? How many men read it ahead of you?

You would receive a clean, fresh copy if you had a personal subscription—and you wouldn't have to wait—you would be first to read it.

Use coupon below.

INTERNATIONAL PROJECTIONIST.

19 West 44 St., New York 18, N. Y.

Enter my subscription for 1 year—12 issues—\$2.50

2 years—24 issues—\$4.00

Foreign and Canada: Add 50c per year.

Name

Address

City State

Defense is your job, too—how to help your country now



★ “The Defense* Bonds I bought through Payroll Savings in '41 helped me to buy my new home!” says **G. F. Nelson**, manufacturing technologist at Shell Oil Company. Congratulating Mr. Nelson is Shell Vice President and former Air Force General “**Jimmy**” **Doolittle**, who adds, “At Shell we believe in Payroll Savings—it’s a patriotic and *practical* way to do a job for defense!”



★ “The Savings Bonds I’m buying now for America’s defense will add almost \$100 a month to my company pension when I retire,” SP Engineer **Frank Bucher** tells his old friend, **A. T. Mercier**, President of the Southern Pacific Railroad. “They’re an extra step toward independence in which the railroad helped me by encouraging me to join the Payroll Savings Plan.”

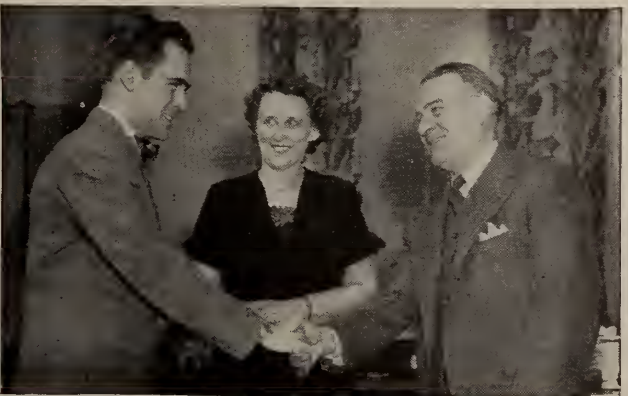

★ **Mrs. Eleanor Minkwic**, drill press operator of Burroughs Adding Machine Company, introduces her Army veteran son **Vernon**, to her boss, Burroughs President **John S. Coleman**. “In 1942 I began buying Bonds through Payroll Savings at Burroughs,” says Mrs. Minkwic. “Today they’re helping **Vernon’s** G.I. allowance to see him through college!”

TEAM UP WITH THESE TYPICAL AMERICANS IN THE PAYROLL SAVINGS PLAN!



★ **Pasquale Santella**, millwright at United States Steel Company’s Carrie Furnaces of the Homestead District Works, has a very personal reason for buying Savings Bonds. As he told **C. F. Hood**, United States Steel Company executive vice president, “My son **Tony**, 19, is missing in Korea. Used to be I bought bonds because it was my duty and it was a good way to save money. Now I want to help lick the Reds and get **Tony** back. I buy one bond every payday and when Uncle Sam needs more money, I’ll buy *more* bonds.” He has bought bonds regularly since 1943; has never cashed one.

* *U.S. Savings Bonds are Defense Bonds
Buy Them Regularly!*

TODAY join with these Americans—business leaders and employees—in their drive to make our country and our citizens more secure. If you’re an employee, go to your company’s pay office *now* and start buying U. S. Defense Bonds through the Payroll Savings Plan—the safe, sure way to save for America’s defense and for personal dreams-come-true.

If you’re an employer, and have not yet installed the easily handled Plan, you will soon be contacted by one of industry’s leading executives. Sign up with him—and help him put the Plan in every company! It’s a practical, hard-sense way to help preserve our nation’s future, its fortune, and the very institutions that make our lives worth while!



Your Government does not pay for this advertising. It is donated by this publication in cooperation with The Advertising Council and the Magazine Publishers of America.



Simplex
TRADE MARK REG'D

CHOSEN

Again!

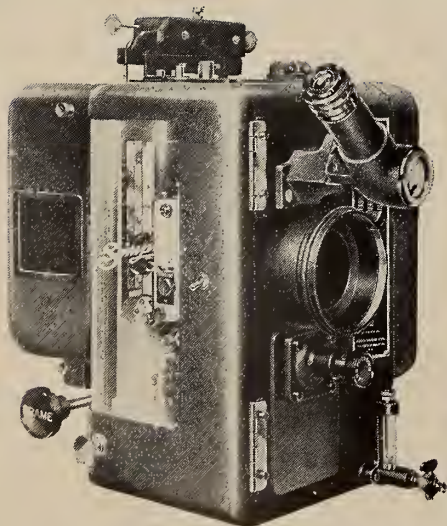

To assure the maximum movie enjoyment to the seven million people who visit it each year,

**RADIO CITY
MUSIC HALL**

naturally demands the best. That is why this, the world's leading theatre, has chosen to install SIMPLEX X-L, the world's leading projector!

Simplex
TRADE MARK REG'D

X·L

PROJECTOR

ENJOY AN EVENING OUT

— GO TO THE MOVIES

MANUFACTURED BY INTERNATIONAL PROJECTOR CORPORATION • DISTRIBUTED BY NATIONAL THEATRE SUPPLY

PROJECTIONIST

INTERNATIONAL



JUN 25 1951

THE LIBRARY OF
CONGRESS
SERIAL RECORD

JUL -5 1951

JUNE

1951

VOLUME 26

• NUMBER 6

30c A COPY • \$2.50 A YEAR

ALONGSIDE THESE LAMPS STAND THE WORLD'S FINEST PROJECTIONISTS

Peerless

1-KW TO 70 AMPS

MAGNARC
TRADE MARK REG.

"HY-AX" ARC MAGNET

"HY-LUMEN" REFLECTOR

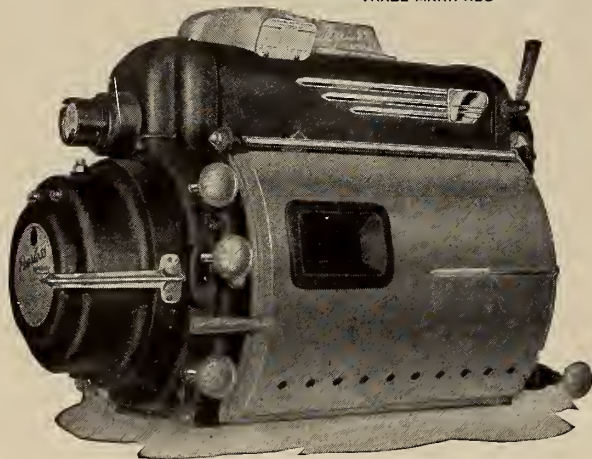

More light at 40 to 70 amperes than ever thought possible. . . Equals and excels any reflector lamp to 85 amperes, whether they be unapproved water-cooled or resurrected "Hi-Lows". . . Highest ratio of honest screen lumens per arc watt. . . At 70 amperes, using an accurated Glass Hy-Lumen Reflector*, with a projector having an efficient revalving shutter, it develops the maximum screen brilliance that can be used without a heat filter at no risk of film damage. . . Operating costs under these conditions are far below that of 85-ampere lamps.

Magnarc Lamps assure 80% side-to-center (SMPE Standard) screen light distribution, not a deceptive 60% or "Hot Center". . . They are all Und. Lab., Inc. listed. . . They are *not* insurance hazards. . . They are and have been for years "The First Choice" of large and small theatres, drive-ins, and the motian picture industry.

* Similar results are *not* guaranteed if all-metal reflectors are used.

"FIRST WITH THE FINEST"

130-180 AMPERES

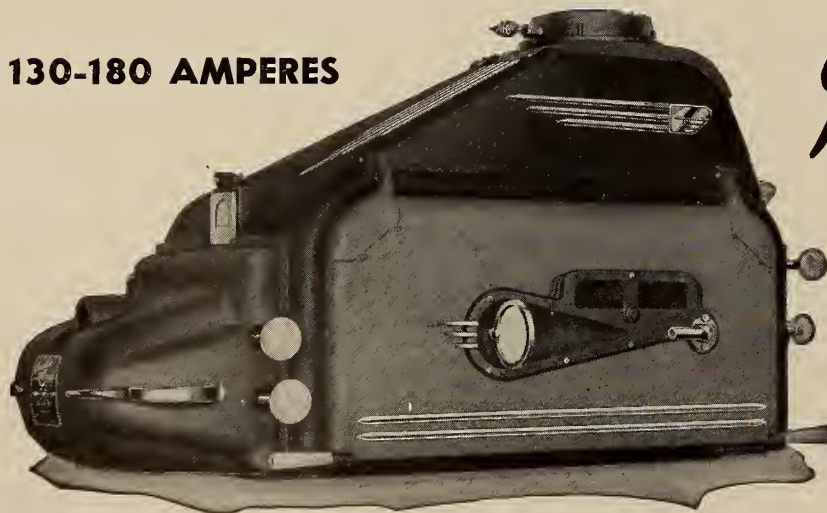

Peerless
HY-AX
CANDESCENT
TRADE MARK REG.

NEW MAGNETIC STABILIZER

This modern lamp produces all the light there is. . . It is the standard equipment of the nation's largest and finest theatres. . . Used by 90% of the largest Drive-In Theatres.

It is the "Omega" for maximum screen brilliance. . . Nothing can even approach it in *white* light volume when used with projectors that have efficient revalving shutters.

Assures satisfying projection for Drive-Ins regardless of the size of the picture, length of throw, and under all weather conditions. . . They are Und. Lab., Inc. listed and, therefore, *not* insurance hazards. . . Heat filter assures no risk of film-heat damage at maximum arc amperage and maximum screen lumens.

"WHY EXPERIMENT?"



J. E. McAULEY MFG. CO.

552-554 WEST ADAMS STREET
CHICAGO 6, ILLINOIS

JUN 25 1951

INTERNATIONAL PROJECTIONIST

With Which Is Combined PROJECTION ENGINEERING



HENRY B. SELLWOOD, *Editor*

Volume 26

JUNE 1951

Number 6

Index and Monthly Chat	3	Tv Impact on Moving-Going Charted in Mid-West Survey	21
Lens Correction: What It Means ALLEN E. MURRAY	5	News Projections	22
Maskless Screen Steadily Gains Favor	10	The Time is <i>Now!</i>	23
Tv Pot Boils Over: Movies Fight Back	13	NAT GOLDEN	
The Magic of Color, II	14	Film Projection in Israel	24
ROBERT A. MITCHELL		A. ZEHNGEBOTH	
Rear Projection in the Theater J. L. STABLEFORD	16	We See Upside Down	24
In the Spotlight	18	Personnel	25
HARRY SHERMAN		'Neu-Zip' Combo Film Scraper	26
Letters to the Editor	19	News Notes	
GPL's New 16-mm Sprocket- Intermittent	20	Technical Hints	
		Miscellaneous Items	

Published Monthly by

INTERNATIONAL PROJECTIONIST PUBLISHING CO., INC.

19 West 44 Street, New York 18, N. Y.

Telephone: MURRAY Hill 2-2948

R. A. ENTRACHT, Publisher

SUBSCRIPTION REPRESENTATIVES

AUSTRALIA: McGills, 183 Elizabeth St., Melbourne

NEW ZEALAND: Te Aro Book Depot, Ltd., 64 Courtenay Place, Wellington

ENGLAND and DOMINIONS: Wm. Dawson & Sons, Ltd., Macklin St., London, W. C. 2

YEARLY SUBSCRIPTION: United States and possessions, \$2.50 (two years, \$4); Canada and foreign countries, \$3; single copies, 30 cents. Changes of address should be submitted two weeks in advance of publication date to insure receipt of current issue. Entered as second class matter February 8, 1932, at the Post Office at New York, N. Y., under the act of March 3, 1879. Entire contents copyrighted 1951 by International Projectionist Publishing Co., Inc. INTERNATIONAL PROJECTIONIST is not responsible for personal opinions appearing in signed articles in its columns.



MONTHLY CHAT

MANY hundreds of words anent various aspects of theater television have appeared in this corner, with very few of them even faintly suggestive of enthusiasm as to the course being followed by the exhibition field in developing Tv into a potent box-office assist. Happenings of the past month, however, have clearly indicated that the film industry no longer intends to stand idly by and see its economic structure swept away by the onrush of Tv in the home field.

It remains to be seen whether exclusive programs offered via theater Tv will prove a strong enough magnet to make people bestir themselves and move out of their homes to the theater—the notion of free Tv programs has become firmly imbedded in the public mind.

But the existence of 100 definite orders for theater Tv units, with many more a likely possibility within the next few months, plus the vigorous action of an exhibitor group in pressing for exclusive program fare (mostly sports, it's true) augurs well for the future.

The recent Joe Louis-Lee Savold boxing match, by no means a first-class attraction, filled a 3346-seat Albany, N. Y., theater to overflowing, with standees six rows deep and other patrons sitting in the aisles. This, at a higher admission price and with a line of patrons several blocks long standing in the rain for several hours waiting to gain admittance. New York newspapermen assigned to cover the event expressed amazement at the showing and stated that sports promoters had the answer to their recent box-office woes.

Whatever develops on the theater Tv front, the organized crafts in the amusement field—from cameramen right down the line to the theater stage and projection room—should lose not a day in exploiting their present strategic position and moving in on Tv on all fronts. The first requisite, of course, is competency, and this may be accomplished only by prompt and sustained action by craft officials in providing their members with a means to learn every angle of the Tv set-up. This will take a tall lot of doing, but done it must be—and at once.

In those areas in which theater Tv units are already installed, as well as those spots to be ready soon, the organized craft should miss no opportunity to familiarize themselves with both equipment and technique. Following this, there should be intensive and extensive exchange of information between craft units.

Information relative to the fundamentals of the Tv art may be obtained in a variety of ways, including the printed page, but there is no substitute for actual experience in handling the equipment itself under actual showtime conditions. This much having been done, there will be no cause for recriminations and self-reproach no matter what develops in the theater Tv field.

Largest screens demand **nothing more...**



for
**the brightest
pictures at
lowest
operating cost!**

- ◆ Air-cooled rotating positive carbon feeding mechanism.
- ◆ Big 16½" reflector matches high speed f/1.9 lens.
- ◆ Automatic arc crater positioning.
- ◆ Stable burning and complete combustion at the arc, to avoid any black soot, are attained by a jet of air directed just above the arc.
- ◆ White smoke, which would otherwise cloud the mirror, is also diverted by this air stream.
- ◆ Unit construction permits instant removal of components for cleaning.



NATIONAL EXCELITE
75 to 130 ampere high intensity reflector type
PROJECTION ARC LAMP

Distributed by

NATIONAL

THEATRE SUPPLY

Division of National • Simplex • Bludworth, Inc.

"THERE'S A BRANCH NEAR YOU"



Lens-Correction: What it Means

By ALLEN E. MURRAY

Scientific Bureau, Bausch & Lomb Optical Company

Despite IP's extensive coverage of projection optics, the color-correction of lenses still is not generally understood, a recent survey of reader-preference indicates. This topic has been covered previously in IP, but the imminent advent of theater Tv, with its more exacting color-correction requisites, lends timeliness to the accompanying summary of the latest data on this topic.

COLOR-CORRECTION in lenses is not a new wrinkle introduced as a consequence of the growing popularity of color film. Lens designers and opticians have been laboring over the color-corrections since the first lenses were assembled into optical systems. The term "color-corrected" is not so profound that, like "abracadabra" or "open sesame," it should become a conjurer's word to call up the perfect lens. "Color-corrected" to the optical designer and optician has a very definite meaning, much as it may have been corrupted to include application to almost any type of lens.

A color-corrected lens, in the language of the designer, is one satisfying two rather stringent specifications, and no lens failing to fulfill these two requirements can fairly be called "fully color-corrected."

Historically, unwanted color in images was recognized very early, and constituted one of the first challenges to the lens designer's skill. The researches aimed at discovering the whys and wherefores of this annoying color led to a better understanding of lenses in general, and to new glasses, and even today are not completed.

The state of the color-corrections in a lens system is fundamental in the per-

formance of the system and constitutes one of the first considerations in design. The subject is rather complicated, as there are in reality two distinct color aberrations the designer must eliminate before he is entitled to say that his system is color-corrected.

The Behavior of Light

But before we undertake to amplify this statement, we must refresh our memories with a few facts of how light behaves.

Light travels in vacuum at the astounding rate of 186,000 miles per second: that is, *all* light is conjectured to do so—blue, yellow, red, infra-red, *etc.*—it all skips merrily along at this dizzy rate in empty space.

But something happens to this light when it reaches a region filled with a

more tangible substance. What happens is exactly the same thing that occurs when a train hits a snow bank, or a football player enters a broken field—a reduction of speed. At the boundary of the optically denser medium, the light beam is bent, or refracted, if the angle at which the beam hits the denser medium is other than 90°.

Specifically, as Fig. 1 shows, on entering a medium in which the speed is less the beam of light is bent toward the normal, an imaginary line perpendicular to the surface. The reverse is true on leaving.

The crux of the color effects is that in spite of the fact that all colors are transmitted through empty space with the same velocity, they insist upon being treated differently when traveling through ponderable matter. In glass, for instance, red light will travel about 3,000 miles per second *faster* than blue light. This speed differential has as its consequence the greater bending of blue light over red light, causing the dispersion shown in Fig. 2.

Achromatic Lens Combinations

In the design and manufacture of photographic objectives, several different types of glass are used whose basic action is illustrated in Fig. 2. One type is of low index of refraction, *i.e.*, it retards light little in passage. This glass, in general, will retard the blue only slightly more than the red.

At the other extreme are the glasses of high index, in which the velocity of light is lower, and this in turn means a greater angle of deviation whereby the blue is affected much more than the red,

FIGURE 1

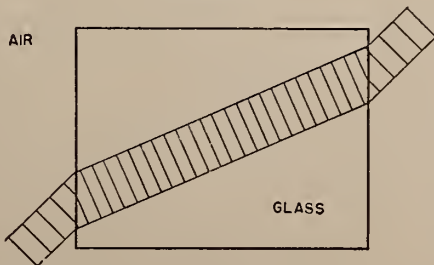

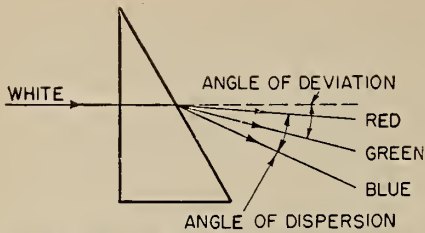

Showing action of white light entering material of low refractive index.

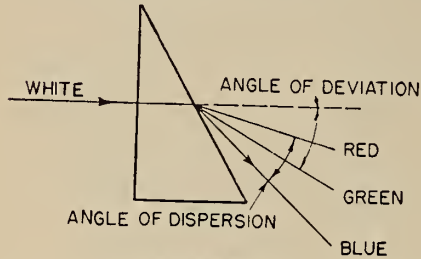

FIGURE 2

White light entering material of high refractive index, at the same angle as above.

so that the angular dispersion is greater.

Sir Isaac Newton, who founded much of optics as we now know it, from his extensive experience with the glass prisms of his day, concluded, erroneously, that dispersion is always proportional to the deviation and that, as a consequence, achromatic combinations are impossible. Sir Isaac committed one of his rare mistakes in concluding that achromats are impossible and that the reflecting telescope is the best answer to the color problem.

Not long after Newton's death, the first achromats were made in England by combining a positive crown and negative flint lens to produce the basic type of achromatic doublet.

We have seen in Fig. 2 that a ray of light, upon passage through a prism, is bent, or deviated, in the direction of the base. This is essentially the fundamental reason for the action of lenses of all kinds. The curved surfaces act like an assembly of an infinite number of small prisms, deviating each ray striking the surfaces sufficiently to bring it to a reunion, real or virtual, with the other rays forming the image.

A positive lens will *converge* parallel rays to a real focus; while a negative lens will *diverge* parallel rays, making them act as if they came from a point, the virtual focus.

From what was said previously concerning dispersion, it is apparent that *any simple lens cannot have one definite, fixed focal point for all light*. Since the light-bending power, or refractivity, of glass is greater for blue than for the red, the blue light will focus at a point nearer the lens than the red. This situation is illustrated in Fig. 3. This is the simplest and most readily grasped type of chro-

matic aberration, and usually the first corrected.

In practice, this longitudinal chromatic aberration will mean that there is no one focal point on the axis but several, depending on the color of the light used. A photograph made with a simple positive lens would show a large shift from visual focus to photographic, even with panchromatic negative material. The "chemical focus" of the old-time photographers was of this nature.

Axial Chromatism Correction

A perfect lens cannot be made, and even in the best lenses there remains a very small residual of this aberration, so that when a color-blind emulsion responding only to the blue is used, a shift towards the lens is usually necessary—the so-called "chemical focus." This effect is familiar also to those who have used infra-red sensitive emulsions in their cameras: for best results, it is usually necessary to rack the lens *out* a trifle.

A further result of this irresolution of focal points is the situation shown in Fig. 3, where at the blue focus the red rays create a red disc, and at the red focus the blue rays create a blue halo. A point object could hardly be photographed as a point under these conditions.

This axial chromatism is not difficult to correct and, as noted before, is given

there existed an optical material with a given amount of dispersion and no refractive power, for then correction could be effected with a plane parallel sheet of this wonderful material. Actually, the only practical material for this task is a glass which has a fortuitous relationship of refractivity to dispersion such that the dispersion will effectively cancel that of the positive lens, while the refractivity is insufficient to cancel completely the convergence of the positive lens.

The lens component effecting this achromatism is negative, as shown in Fig. 4, and must have higher refractivity and dispersion than its positive mate.

This combination, then, will bring light of any two colors to a common focus on the axis. The other colors will focus at points practically identical with the chosen colors. Thus this lens would give a color-free star image on the axis.

Other Chromatic Aberration

The other type of chromatic aberration is a bit more difficult to understand. It is somewhat more complicated both to explain and to show in a drawing. Some of us may recall mention in our reading concerning optics of certain things called "cardinal points," "ideal planes," etc. These points and planes are convenient ways of describing the properties of lens

FIGURE 3

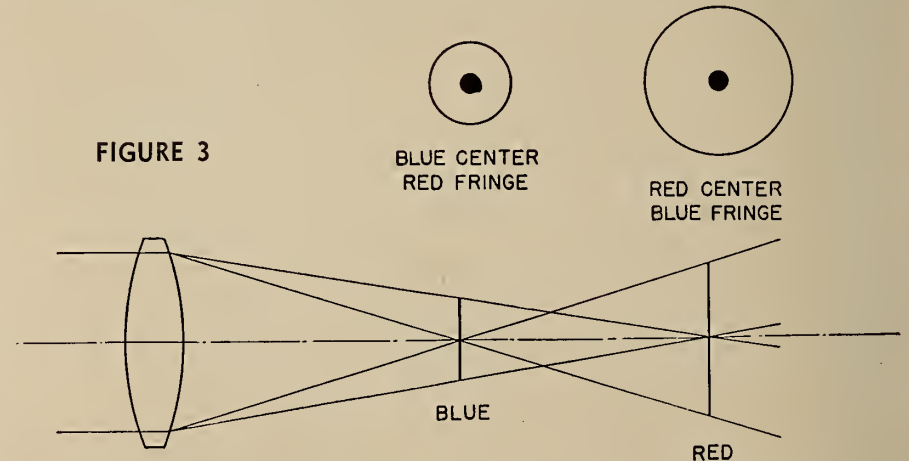

high priority. The secret lies in the relation of dispersion to deviation. Consider for a moment a simple positive lens as shown in Fig. 3. The marginal rays have been deviated toward a focus, and at the same time because of the dispersion of the glass, the red and blue rays are aimed at different points on the axis.

Now, everything would be perfect if

systems and are indispensable to the lens designer.

Briefly, these cardinal points can be looked on as points on the lens axis at which the refractive powers of the lenses or lens system are concentrated. The cardinal points and planes are exceedingly useful because they simplify computations by replacing a complex, almost

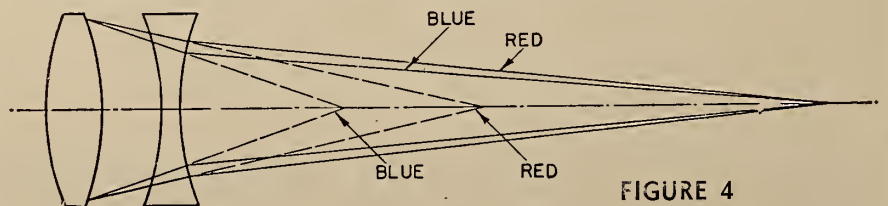

FIGURE 4

Now...

UNIFORM LIGHT

← FROM CENTER TO SIDES →

with this exclusive

RCA EVENLITE

PATENTED

SCREEN

HERE'S HOW

These *graded* perforations taper from full size in center area to no perforations in side areas. Compensate for "hot-spot" effect of projected light.

● An ordinary screen has *uniform* perforations across entire face. Screen surface is *uniform* but projected light *isn't*. Result: "hot-spot" effect . . . reflected light is brighter at center of screen, less bright at sides.

RCA Evenlite screen has varying perforations, tapering from full size in center area to no perforations in side areas. Result: *uniform* lighting . . . full brightness at center of screen, full brightness at sides.

Here at last is a practical solution to the screen light distribution problem . . . a screen that actually compensates for non-uniform light projected from an arc lamp. At center, where perforations are maximum, hole size *does not exceed*

**eight per cent*. So Evenlite gives you as much light at center as any standard-perforation screen. At sides, where perforations are zero, Evenlite gives you at least *eight per cent more light*, out on the dim edges where every bit of light is needed. And these unperforated side areas are *big!* On larger screens, from 50 to 75% of area *has no perforations!* All this *extra* screen light, with no loss in sound quality.

Look into RCA Evenlite now. It *costs no more* than ordinary screens, yet gives you a uniformity of lighting never before possible. Made of long-lasting, high-reflecting RCA Snowwhite Heavy-weight Vinyl Plastic. Exclusive with RCA. Available immediately . . . so call your RCA Dealer for full details . . . *today!*

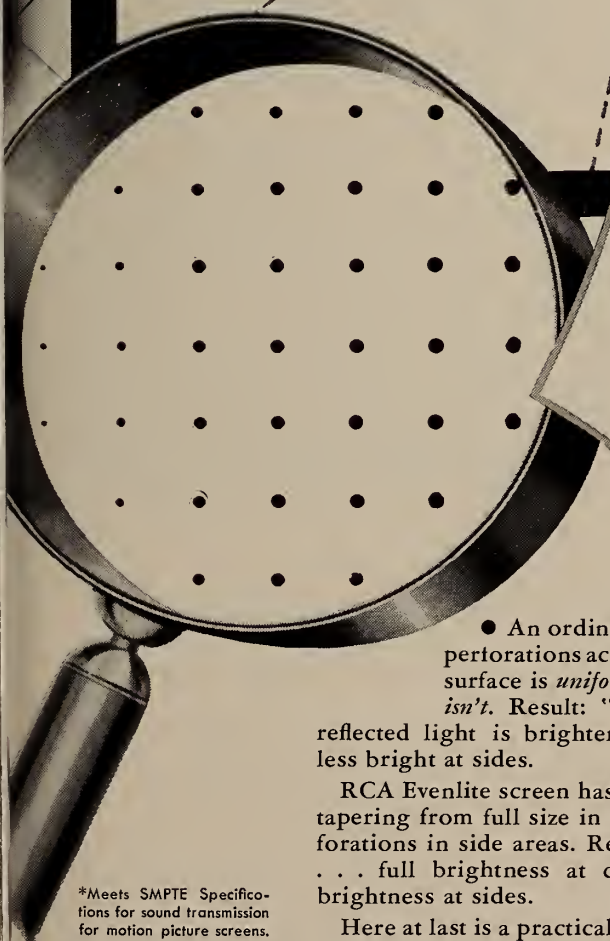

*Meets SMPTE Specifications for sound transmission for motion picture screens.



THEATRE EQUIPMENT
RADIO CORPORATION of AMERICA
ENGINEERING PRODUCTS DEPARTMENT, CAMDEN, N.J.

In Canada: RCA VICTOR Company Limited, Montreal

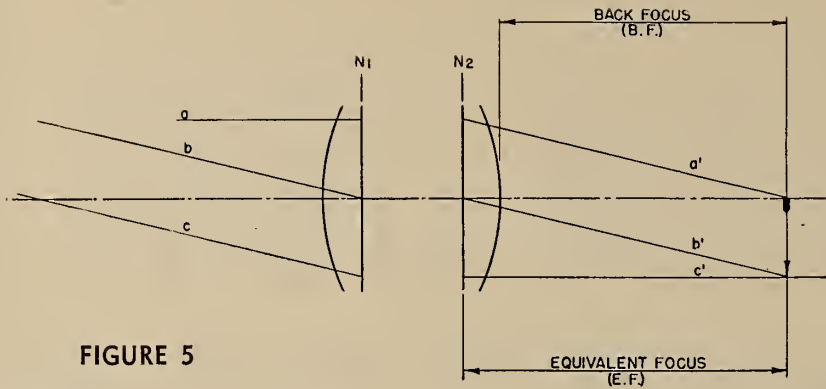

FIGURE 5

unmanageable system by points at which all the refraction can be considered to occur, or more graphically, by thin lenses whose laws are simple and easy to handle.

Irrespective of the distance from the rear surface of the lens to the focal point in parallel light (B.F.) the equivalent focal length (E.F.) of a lens is defined as the distance from the second nodal point (cardinal point) to the second principal focal point (Fig. 5).

We are all familiar with the fact that even with infinitely distant objects the image size is proportional to the focal length of the lens used. The 50-mm lens on miniature cameras will yield an image one-third the size of that formed by a 6-inch lens.

Now, it is a most unfortunate fact that the cardinal points have positions dependent on the refractive index of the glass comprising the lens. Expressed in other words, each color has its own cardinal points which can be distinct from those of any other color. Now, if the lens is color-corrected axially, i.e., if the red and blue colors unite in one focal point on the axis, and if the nodal points in the two colors are different, automatically the lens must have different focal lengths in the two colors. This is shown in Fig. 6.

However, these different focal lengths, as we saw previously, mean differently sized images: that is to say, the magnification will be different, depending on the color (Fig. 7). It is for this reason that this second type of chromatism is spoken of as chromatic difference of magnification, or lateral color.

Lateral Color Aberration

In a lens afflicted with this aberration the points in the margin of field are drawn into spectra, or rainbows. This particular aberration is most annoying even with black-and-white film, for it quickly sets the limit of usable field by producing a graded soft focus near the margins.

In the correction of this aberration, advantage is taken of the fact that some lens system will give a spectrum with the red end closer to the axis; while others will give a rainbow oriented the other way around. In the correction of lateral

color, then, systems of these apposing characteristics are balanced against each other until a satisfactory compromise is found.

We have now seen the two types of pure chromatic aberration—longitudinal chromatic aberration, and chromatic difference of magnification. The former, the simpler type, is manifested by the ab-

practice its effects will be mitigated by stopping-down, for then the effective depth of focus is increased and the image is less sensitive to improper focus. Longitudinal chromatic aberration is corrected by combining a positive lens with a negative lens of higher refractive index and dispersion and of such power that the dispersion of the positive lens is annulled, but its convergence not canceled, so that a union of the red and blue colors occurs on the axis.

'Full Color-Corrected'

The second chromatic aberration is more complex and manifests itself in differently sized images in different colors. This chromatic difference of magnification is troublesome even in black-and-white photography, and the best lenses are corrected for this aberration.

Only the photographic objectives designed with this aberration pared to tolerable limits can be spoken of as "full color-corrected." This aberration is pro-

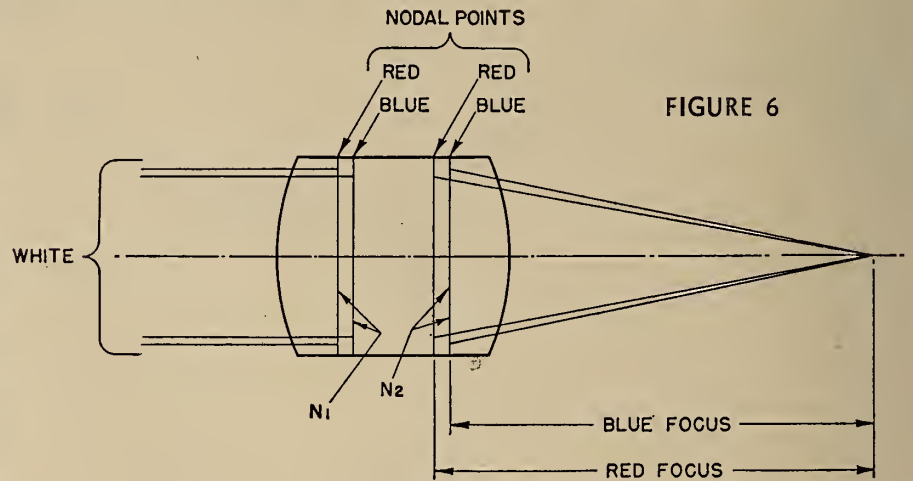

FIGURE 6

sence of one single focal point for all colors, with the existence of a distant point for each separate color. This is a very troublesome aberration and is corrected in all but the most inexpensive lenses. These lenses can be spoken of as being "color-corrected" only to the extent that there is little or no shift of focal point with color.

This aberration is in theory independent of the aperture of the lens, though in

portional to the image height, thus becoming worse toward the corners of the picture. Stopping down the lens is without effect on this aberration. It can be corrected by employing combinations of elements of opposing tendencies, so that one set cancels the effects of the preceding.

The corrected lenses of the reputable
(Continued ft. of Col. 1, page 10)

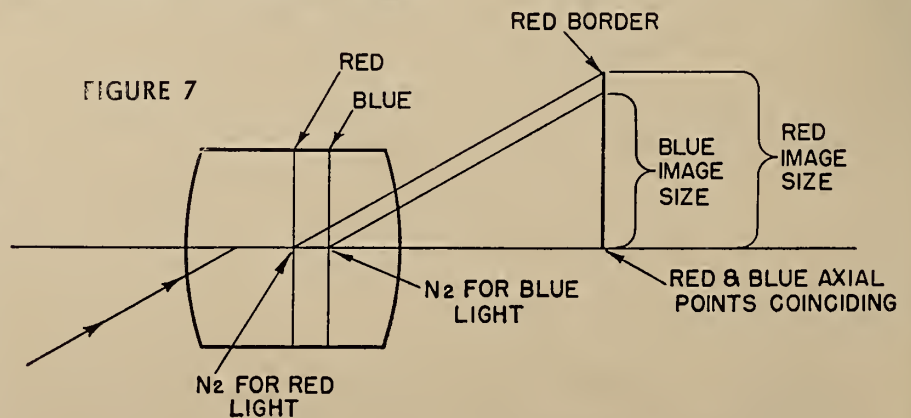
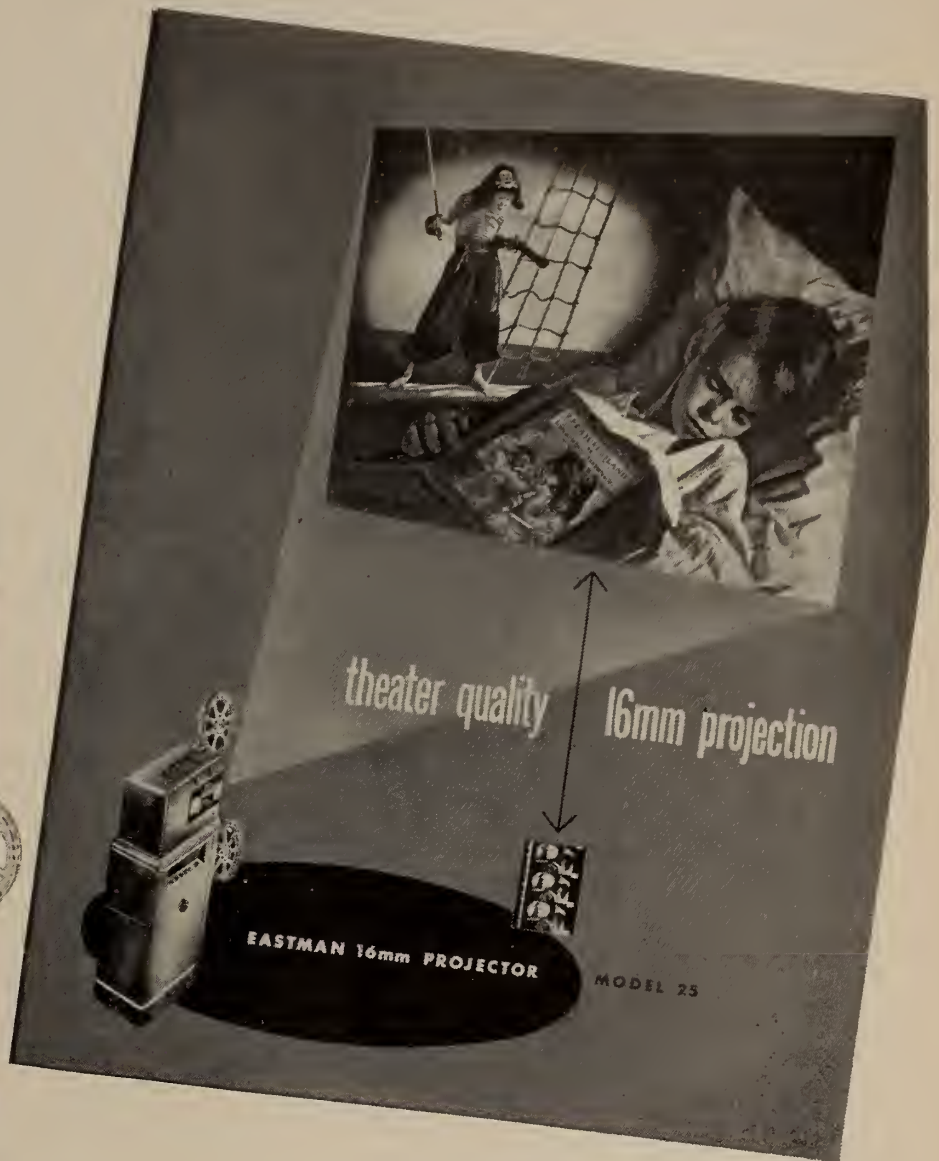
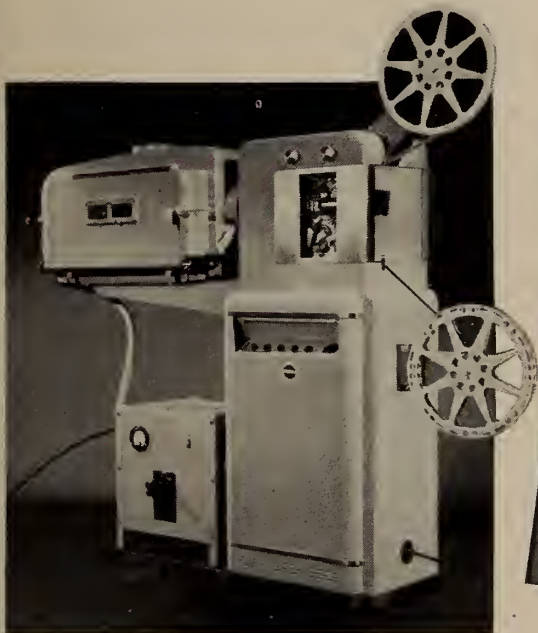

FIGURE 7

The Eastman 16mm. Projector, MODEL 25



HERE is a precision-designed, craftsman-built projection instrument which delivers a screen image and sound reproduction from 16mm. film that compares favorably with the performance of the most advanced 35mm. equipment. You can be certain of theater-quality projection of your 16mm. sound films when they are shown with an Eastman 16mm.

Projector, Model 25. The standard model may be fitted with tungsten or carbon arc lamp.

For more detailed information, including mechanical and installation specifications, fill out the coupon below now, and mail it today. Your free copy of the booklet, "Theater Quality 16mm. Projection," will be in the return mail, postpaid.

Motion Picture Film Department
Eastman Kodak Company
Rochester 4, N. Y.

East Coast Division
342 Madison Avenue
New York 17, New York

Midwest Division
137 North Wabash Avenue
Chicago 2, Illinois

West Coast Division
6706 Santa Monica Blvd.
Hollywood 38, California



Eastman Kodak Company
343 STATE STREET
ROCHESTER 4, N. Y.
DEPT. 8

Please send copy of
"Theater Quality 16mm.
Projection" at earliest
convenience.

NAME _____
COMPANY (OR THEATER) _____
STREET _____
CITY _____ ZONE _____ STATE _____

Maskless Screen Steadily Gains Favor

Renewed interest in the maskless screen, and its concomitant of surrounding illumination, was very definitely in evidence at the recent SMPTE Convention in New York. Supplementing the various articles on this topic which have appeared in IP over the past several years is the appended commentary by a prominent lighting engineer.

WITH the trend toward higher levels of schoolroom and industrial lighting, there is also a trend toward higher levels of illumination in theater auditoriums while the picture is on the screen. In addition to the obvious advantages from a public safety standpoint, another result is reduction of eyestrain resulting from reduced contrast between the screen and the area surrounding it.

Evidence from another quarter supporting the argument for lower contrast between visual task areas and their surround was available in abundance at the office equipment exhibits of the National Office Managers Assoc. Convention in New York recently. All desk manufacturers are offering tops more nearly the color of the paper you are looking at rather than the print you are reading. Even televising authorities tell Butch to have lights on in the room during the Hopalong Cassidy show.

Film Theaters Lagging Behind?

Why don't more theaters follow the swing? Now that large aperture lenses

LENS CORRECTION

(Continued from page 8)

makers have all been designed with this aberration in mind and can justly be spoken of as being fully color-corrected. However, it is well to remember that nothing perfect is manufactured, and that with the most refined tests it might be possible to demonstrate some lateral color with the most nearly perfect lens made. This would be without significance, however, since the test necessarily would be artificial and would not correspond to the conditions of use of the lens. If the longitudinal chromatic aberration has been corrected, and if the lateral aberration cannot be detected on the film, for all practical purposes the lens is "fully corrected."

Full color-correction is as essential in the best photography and projection with black-and-white emulsions as it is with color film. The effect of lateral color in the case of the former is to create a soft focus effect toward the margins, while with color film registration difficulties are the consequence of this aberration.

Color photography and projection has introduced no new element into the design of good objectives. With color film the color aberrations, particularly lateral color, becomes visible as color defects. The best lenses have always been fully color-corrected.

and methods of cooling the projector gate, the film and the carbon clamps are available, the majority of theaters are physically able to use larger screens and higher levels of screen brightness which permit a substantial increase of auditorium light. Add also an illuminated screen surround and the patrons will receive something new in the way of motion pictures.

Light borders are replacing dark in two ways:

1. The screen end of the auditorium is shaped like the inside of an egg shell (the big end) with the side walls and ceiling sweeping in at an increasing rate to meet the edge of the screen. Wall and ceiling are finished a very light color, almost white, and receive a great deal of diffuse reflected light from the screen.

Brightness Ratio Very Important

The ratio of apparent screen brightness to apparent surround brightness is set by the shape, texture and color of the walls and ceiling.

Once a desirable ratio is established it stays that way, because a high-key scene automatically has a fairly bright surround, and a low-key scene, such as the first reel of "Great Expectations," will reflect practically no light to the surrounding walls. It seems mighty important to select the brightness ratio that gives minimum fatigue, and this calls for clever architectural design.

A Typical Installation

The Crown Theater in New Haven, Conn., is an early practical example. There is no proscenium and there are no curtains. It is a small motion picture theater that does not feel the urge to hide its screen behind heavy drapes. During intermission the white screen is occupied

with a slide projected from the projection room. The result is quite a pleasant one.

Britain's Telekinema System

2. Another and more complex system is being used in Telekinema, the motion picture exhibit featured at the Festival of Britain. The surround is projected along with the picture and uses light reflected from the rear of the projector shutter, which is silvered, and a special projection optical system that "works" only during the pull-down half of the projection cycle.

The result is an illuminated border synchronous with the picture, which requires no special attention on the part of the projectionist.

Movies Two Miles Under Water

MOTION PICTURES of the expansion and contraction of explosion bubbles, taken at a depth as great as two miles under the surface of the ocean at a rate of 20,000 frames per second, are helping U. S. Navy scientists to gain new knowledge of the behavior, effectiveness and design requirements of underwater explosive weapons.

The explosion bubble is a gas globe formed by the hot, expanded gaseous products of detonation. The cameras used in a recent Navy project were an Eastman Hi-Speed, a 35-mm Fastax, and a rotating mirror frame camera best described as a modified Bowen. Each was shock-mounted in a heavy, watertight case.

Intricate Optical System Used

The latter camera, used for making studies at greater depths, was enclosed in a spherical case with an inside diameter of 22 inches and walls 1¼-inch thick. In this camera, the image is formed on a spinning mirror which has the focal axis of the taking lens system for its axis of rotation.

The plane of reflection of the mirror is 45 degrees to this axis. The image is thus reflected through the framing lens to the stationary film. With the mirror revolving at the rate of 18,000 r.p.m., 100 pictures can be taken at the rate of 30,000 frames per second. The light source most commonly used consisted of a number of focal plane flashbulbs having a flash duration of about 75 milli-seconds.

American equipment is featured around the world, as attested by this display of Simplex visual and sound projection equipment by Evergreen Pictures in the Taj Mahal Hotel, Bombay, India.





BRIGHTEST SPOT IN THE WORLD!

ITS AREA is less than one quarter square inch. It is the most powerful "point source" of light in the world. It is the crater in the tip of an experimental positive "National" High Intensity carbon.

Into this tiny spot is packed the same amount of light which would be emitted by 137,000 brightly burning candles!

This crowding of a terrific amount of light into a small area is a feature of the "National" carbons used in movie production and projection. It is called *intrinsic brilliance*. This is what makes your pictures so bright and pleasing to look at.

Furthermore, the light emitted by "National" High Intensity Carbons is the closest approach to sunlight. It has a continuous spectrum and contains all the colors of the rainbow. This makes color movies glow with rich natural detail. Your theatre patrons like it — their approval shows up in the box office.

When you order studio
or projector carbons
— order "NATIONAL"!



The term "National" is a registered trade-mark of Union Carbide and Carbon Corporation

NATIONAL CARBON COMPANY, A Division of Union Carbide and Carbon Corporation

30 East 42nd Street, New York 17, N. Y.

District Sales Offices: Atlanta, Chicago, Dallas, Kansas City, New York, Pittsburgh, San Francisco

IN CANADA: National Carbon Limited, Montreal, Toronto, Winnipeg

BATHE 'EM IN LIGHT

THE TROUPER

THE TROUPERETTE

with the **TROUPER** and the **TROUPERETTE**

Theatres, auditoriums, arenas, colleges, schools, hotels, ice shows, lodges and road shows appreciate the sharp, dazzling snow-white spot projected by the Strong Troupers High Intensity Arc Spotlight. Drawing only 10 amperes from any 110-volt A.C. convenience outlet, the Troupers makes the use of heavy rotating equipment unnecessary. With an adjustable, self-regulating transformer an integral part of the base, the Troupers is easily portable and readily disassembled for shipping.

The high efficiencies of the Troupers are largely attained by the optical system which utilizes a silvered glass reflector and a two-element variable focal length lens system. The automatic arc control maintains a constant arc gap, free from hiss or flicker. A trim of carbons burns one hour and twenty minutes at 21 volts and 45 amperes.

The Strong Troupers Incandescent Spotlight is especially popular with small theatres, schools, night clubs and industrial

shows, where physical dimensions and price are factors and where the tremendous light volume of an arc lamp is not necessary. It can be plugged into any 110-volt convenience outlet.

It projects far more light than any conventional, incandescent spotlight. This increased brilliancy is made possible by a variable focal length objective lens system, a 5¼-inch silvered glass reflector and Fresnel lens used with a standard 115-volt, 1000-watt prefocused projection type bulb. As contrasted to the conventional incandescent spotlight, with which the spot size is varied solely by iris, to result in substantial light loss, the Troupers utilizes all the light through most of the spot sizes. The Troupers delivers 6½ times brighter head spots with sharp edges from head spot to flood. A horizontal masking control can be angled at 45 degrees in each direction. The fast operating color boomerang accommodates six slides. The mounting stand is adjustable for height.

SEE ANY OF THE FOLLOWING DEALERS OR USE COUPON FOR OBTAINING LITERATURE

ALBANY, N. Y.—Nat'l Theatre Supply Co.; Albany Theatre Supply
 ATLANTA—Nat'l Theatre Supply Co.
 ATLANTIC CITY—Boardwalk Film Enterprises
 AUBURN, N. Y.—Auburn Theatre Equipment
 BALTIMORE—J. F. Dusan Co.; Nat'l Theatre Supply Co.
 BIRMINGHAM—The Queen Feature Service, Inc.
 BOSTON—J. Cifre, Inc.; Nat'l Theatre Supply Co.
 BUFFALO—Dion Products; Nat'l Theatre Supply Co.
 CHARLOTTE—Nat'l Theatre Supply Co.; Standard Theatre Supply Co.
 CHICAGO—Abbott Theatre Equipment Co.; Droll Theatre Supply Co.; Gardner Jansen, Inc.; Grand Stage Lighting Co.; Hollywood Stage Lighting Co.; Midwest Stage Lighting Co.; Nat'l Theatre Supply Co.
 CINCINNATI—Nat'l Theatre Supply Co.
 CLEVELAND—Nat'l Theatre Supply Co.
 DALLAS—Hardin Theatre Supply Co.; Modern Theatre Equipment Co.; Nat'l Theatre Supply Co.
 DENVER—Nat'l Theatre Supply Co.; Graham Bros.
 DES MOINES—Nat'l Theatre Supply Co.
 DETROIT—Nat'l Theatre Supply Co.
 FORTY FORT, PA.—V. M. Tate Theatre Supplies
 GREENSBORO, N. C.—Standard Theatre Supply Co.
 HOUSTON—Southwestern Theatre Equipment Co.
 INDIANAPOLIS—Nat'l Theatre Supply Co.
 KANSAS CITY, MO.—Shreve Theatre Supply; Nat'l Theatre Supply Co.
 LOS ANGELES—J. M. Boyd; C. J. Holzmuller; Nat'l Theatre Supply Co.; Pembrex Theatre Supply Corp.
 LOUISVILLE—Falls City Theatre Supply Co.

MEMPHIS—Nat'l Theatre Supply Co.
 MILWAUKEE—Nat'l Theatre Supply Co.; R. Smith Co.
 MINNEAPOLIS—Minneapolis Theatre Supply; Nat'l Theatre Supply Co.
 NEW HAVEN—Nat'l Theatre Supply Co.
 NEW ORLEANS—Nat'l Theatre Supply Co.
 NEW YORK CITY—Nat'l Theatre Supply Co.
 NORFOLK—Nat'l Theatre Supply Co.
 OKLAHOMA CITY—Nat'l Theatre Supply Co.; Oklahoma Theatre Supply Co.
 PHILADELPHIA—Blumberg Brothers; Nat'l Theatre Supply Co.
 PITTSBURGH—Atlas Theatre Supply; Nat'l Theatre Supply Co.
 SALT LAKE CITY—Inter-Mountain Theatre Supply Co.
 SAN FRANCISCO—C. J. Holzmuller; Nat'l Theatre Supply Co.; W. G. Preddey Theatre Supplies

SEATTLE—B. F. Shearer Co.; Nat'l Theatre Supply Co.
 SIOUX FALLS—American Theatre Supply Co.
 ST. LOUIS—City Electric Co.; Nat'l Theatre Supply Co.
 TOLEDO—Theatre Equipment Co.
 WESTERLY, R. I.—G. H. Payne Motion Picture Service
 CANADA—
 Dominion Sound Equip., Ltd., Montreal, Que.
 General Theatre Supply Co., Toronto, Ont.
 General Theatre Supply Co., St. John, N. B.
 General Theatre Supply Co., Vancouver, B. C.
 General Theatre Supply Co., Montreal, Que.
 General Theatre Supply Co., Winnipeg, Man.
 Perkins Electric Co., Ltd., Montreal, Que.
 Perkins Electric Co., Ltd., Toronto, Ont.
 Sharp's Theatre Supplies, Ltd., Calgary, Alta.

THE STRONG ELECTRIC CORPORATION

"The World's Largest Manufacturer of Projection Arc Lamps"

14 CITY PARK AVENUE

TOLEDO 2, OHIO

Please send free literature on the Strong Troupers Incandescent Spotlight;
 Strong Troupers Arc Spotlight.

NAME _____

COMPANY _____

STREET _____

CITY & STATE _____

Tv Pot Boils Over; Movies Fight Back

THE Tv pot boiled over during the past month, with most of the heat being generated by the long-quiescent motion picture industry. While much too early to evaluate the end results of the frantic pushing and hauling that ensued in the entertainment arena during this period, it's a cinch that the coming year will be productive of events that will set the pattern for years to come. The developments were:

1. United Paramount Theaters merged with American Broadcasting Co. (subject to FCC and stockholder approval), and thus added five wholly-owned AM-FM-TV stations and 289 affiliated stations to the 650 theaters which it already controls. At least 22 of these theaters will be equipped with large-screen Tv equipment by early Fall.

2. A group of motion picture theaters obtained the exclusive rights, although on a restricted coverage basis, to the Joe Louis-Lee Savold heavyweight fight held at the Polo Grounds on June 13. No theaters in the New York and adjacent areas were included in the deal.

100 Theater Tv Sets in Work

3. It was learned definitely that more than 100 theater Tv equipments are now being manufactured by RCA — which means definite orders therefor.

4. Almost a certainty is that the exclusive rights to major college football games next Fall will be granted to Tv-equipped motion picture theaters.

5. Paramount Pictures Corp. (not to be confused with U-P Theaters), which already owns a substantial interest in the DuMont Tv-network and manufacturing facilities, purchased an interest in Telemeter, a coin-operated device attachable to home receivers thus presaging a possible Tv subscription service.

Paramount also revealed its 50% ownership of Chromatic Tv Labs, which makes a Tv receiver which will automatically tune to either black-and-white or color transmission, using a 16 or 21-inch direct view tube. This tube would eliminate the need for the rotating disk now used on CBS color transmissions.

RCA's Pay-as-You-See-System

6. RCA, parent company of the NBC radio and Tv network, formally confirmed for the first time that it has been working on a system of home pay-as-you-see Tv. "There are many ways of doing subscription television," said an RCA spokesman, "Anything that can be done over a wire can be done through the air."

7. The U. S. Supreme Court sustained the legal right of the FCC to approve the CBS system of rotating-disk color Tv as opposed to the RCA all-electronic color tube. Nothing daunted, RCA announced that it did not regard the controversy as ended, and moved promptly to begin experimental color transmissions and to make available to all tube and

set manufacturers full details of its trichromatic color tube.

CBS howled that by this move RCA was again attempting to "delay color by making promises for the future." RCA replied that it was "goodbye to the disk—it's obsolete." Competent observers estimate that home receiving sets will not be affected by the court's decision for several years to come.

All these events are of too recent vintage and, probably, are so interdependent one upon another as to defy analysis, much less a forecast of their impact upon the future, even by those who are intimately associated with them. Time alone will design the pattern.

However, three facts of great significance to motion picture people emerge from the welter of events. These are:

1. The theater field has finally snapped out of a coma and come to the realization that it is do or don't, now or never. Witness: the definite orders for theater Tv equipments, and the evidence that it will make a strong bid for exclusive program material in the form of major events, sports or otherwise. Whether this move is too late, for better or worse, is unpredictable—but the will to fight back is at last evident in the tangible form of making an effort and spending money.

2. Inescapable is the fact that everybody concerned — promoters of major events, Tv networks, talent, manufacturers, movie theaters, and all the working crafts — has jumped on the bandwagon which is headed in the direction of some form of pay-as-you-see, whether in the home or in the theater, as a source of badly needed revenue.

3. The active participation of the large movie producers in the acquisition of Tv properties and their avid continuing scouting of future possibilities makes it inevitable that it won't be too long before they announce flatly their intent to make films for Tv.

In fact, several such units, even though in skeleton form, are right now active in the major Hollywood studios — *for a fact.*

UP-ABC Deal No Help

As for the purchase of ABC by UP, the mealy-mouthed joint announcement of the deal makes it obvious that the combine will do precious little good for if not actual harm to, the motion picture theatre. How about those 289 network affiliates?

As for the theater group gaining the

exclusive on the Louis-Savold fight, this ice-breaker is significant only because of the statement by the boxing monopoly that this is but the "first of a series of such events that will go exclusively to the theater field."

And there are other angles to this deal. Admittedly, Louis and Savold was not a championship fight, and, in fact, was really not a first-class attraction. Then there is the circumstance of the promoters being turned down on their request for \$100,000 from a Tv sponsor for the event, the highest bid being \$60,000. It is doubtful that this outdoor attraction grossed even the latter figure at the gate.

Rather a mangy-looking first exclusive, but still a hopeful portent for the future.

The definite orders for theater Tv equipment and the exclusive on the major college football games brighten up the over-all picture—but positively.

Pay-as-You-See Movie Poison

This mad rush toward the pay-as-you-see goal could be poison for the motion picture theater. It indicates that home Tv as now set up is faltering and will ultimately be relegated to a plodding medium that can offer nothing but 15- and 30-minute segments plus a flock of wornout entertainers and, of vital importance, a dose of the most nauseating verbal garbage in the form of commercials that is ever foisted on the public.

Home Tv, however, would figure to dent the movie theater box-office by about 20%; but a practicable means for establishing a nation-wide pay-as-you-see home Tv service would zoom this figure to 50 or 60%—and goodbye movie theater. A thought: presently there are no channels available for such a service even if the FCC should grant approval.

Over-all, it appears that if the movie theaters can get through this summer in fairly good shape and keep pitching in the matter of acquiring more and more large-screen theater Tv sets and in snaring exclusive program fare, it might yet find itself in a spot where it would wind up with a respectable slice of the entertainment dollar.

Tv 15,000 Times Brighter!

In the past, projection Tv has failed to win public acceptance using projection tubes only 50 times as bright as direct-view tubes. "It now seems entirely feasible to build a receiver tube 6 inches long and less than an inch in diameter, which will have a screen brightness 15,000 times that of today's direct-view tube," declares Philo T. Farnsworth. "With such a tube we shall be able to use a built-in screen in the receiver or to adjust the set so that an image may be projected in 3 x 4-foot size on a separate screen or wall."

The Magic of Color

By ROBERT A. MITCHELL

Second in a series of articles on the "what", "why" and "how" of color.

TABLE A gives the intensity of vermilion, emeraude, and indigo lights required to produce the 48 hues (Fig. 3 is reproduced from the first installment for reader convenience). Zero means "completely off," while 100 signifies "full intensity." When all three lights are shining at full intensity (100, 100, 100), white light is obtained.

The hues are numbered in Table A in such a way that complementaries have the same number. If you add the light intensities for any two complementaries, you will find the sum to be 100, 100, 100.

The column headed *luminosity* indicates the relative visual brightness of the hues when moderately strong illumination is employed. Note that indigo is the least luminous, and yellow the most luminous, of the hues. Note also the slight irregularities in the way the luminosities

vary. The relative luminosity indices of any two hues complementary to one another add up to 10 in all cases.

Table B gives the *percentage* of each primary in the 48 hues. The numbers in the column headed *multiplier* are worth special attention. They are significant in three ways.

First, by multiplying the percentages of components of each hue by the indicated multiplier, the values given in Table A are obtained.

Most 'Dazzling' to Eye

Second, the hues having the highest multipliers are the most "dazzling" to the eye (cyan, magenta, and yellow). All hues having the same multipliers are equally "dazzling," or colorful.

Third, the multipliers offer an astonishing empirical explanation of the hues

commonly accepted as fundamental colors—true red, orange, etc. With the exception of yellow, the "true" hues have multipliers very close in value to 1:29 and 1.63. Here is how the correct positions of these hues are determined in the color scale:

Begin with *yellow*, which attracts attention because it is the most luminous hue. Proceeding down the list from yellow (and continuing down from the top of the list when the bottom has been reached), we find the *second* hue having the *same* multiplier, whether 1.29 or 1.63. This will be a "true" hue.

Xanth, we notice, is 1.6 (closest to 1.63), limonelle is 1.3 (closest to 1.29), and green is 1.25 (closest to 1.29). This determines true green.

Continuing, we encounter aquamarine 1.625 and blue 1.667. This determines true blue.

Continuing, we encounter ultramarine 1.333 and purple 1.3. This determines true purple.

Continuing, we encounter mauvure 1.6 and red 1.625. This determines true red.

Continuing, we encounter scarlet 1.25 and orange 1.333. This determines true

TABLE A. PRODUCTION OF COLORED LIGHTS BY MIXING PRIMARY HUES

Hue	PRIMARY COMPONENTS Relative Light Intensities			Luminosity
	Vermilion	Emeraude	Indigo	
1. Xanth	60	100	0	7.000
2. Chlorise	50	100	0	6.500
3. Chryisine	40	100	0	6.000
4. Limonelle	30	100	0	5.500
5. Thallerian	20	100	0	5.000
6. Reseda	10	100	0	4.500
7. EMERAUDE	0	100	0	4.000
8. Virence	0	100	12.5	4.125
9. Green (true)	0	100	25	4.250
10. Verdante	0	100	37.5	4.375
11. Beryl	0	100	50	4.500
12. Aquamarine	0	100	62.5	4.625
13. Glaucine	0	100	75	4.750
14. Bice	0	100	87.5	4.875
15. CYAN	0	100	100	5.000
16. Cerulea	0	83.3	100	4.333
17. Blue (true)	0	66.7	100	3.667
18. Smalt	0	50	100	3.000
19. Ultramarine	0	33.3	100	2.333
20. Gentian	0	16.7	100	1.667
21. INDIGO	0	0	100	1.000
22. Woad	10	0	100	1.500
23. Violet	20	0	100	2.000
24. Purple (true)	30	0	100	2.500
1. Tyrian	40	0	100	3.000
2. Puocelle	50	0	100	3.500
3. Mauvure	60	0	100	4.000
4. Amaranth	70	0	100	4.500
5. Mulberry	80	0	100	5.000
6. Rubraocinth	90	0	100	5.500
7. MAGENTA	100	0	100	6.000
8. Cherrose	100	0	87.5	5.875
9. Carmine	100	0	75	5.750
10. Red (true)	100	0	62.5	5.625
11. Garnet	100	0	50	5.500
12. Crimson	100	0	37.5	5.375
13. Soarlet	100	0	25	5.250
14. Cardinal	100	0	12.5	5.125
15. VERMILION	100	0	0	5.000
16. Mandarin	100	16.7	0	5.667
17. Orange (true)	100	33.3	0	6.333
18. Pyridian	100	50	0	7.000
19. Safran	100	66.7	0	7.667
20. Aurise	100	83.3	0	8.333
21. YELLOW (true)	100	100	0	9.000
22. Flavelle	90	100	0	8.500
23. Chartreuse	80	100	0	8.000
24. Mascagna	70	100	0	7.500

TABLE B. PERCENTAGE COMPOSITION OF COLORED LIGHTS

Hue	PR MARY COMPONENTS Proportions in Per Cent				Multiplier
	Vermilion	Emeraude	Indigo		
1. Xanth	37.50	62.50	0		1.6
2. Chlorise	33.33	66.67	0		1.5
3. Chryisine	28.57	71.43	0		1.4
4. Limonelle	23.08	76.92	0		1.3
5. Thallerian	16.67	83.33	0		1.2
6. Reseda	9.09	90.91	0		1.1
7. EMERAUDE	0	100.00	0		1
8. Virence	0	88.89	11.11		1.125
9. Green (true)	0	80.00	20.00		1.25
10. Verdante	0	72.73	27.27		1.375
11. Beryl	0	66.67	33.33		1.5
12. Aquamarine	0	61.54	38.46		1.625
13. Glaucine	0	57.14	42.86		1.75
14. Bice	0	53.33	46.67		1.875
15. CYAN	0	50.00	50.00		2
16. Cerulea	0	45.45	54.55		1.833
17. Blue (true)	0	40.01	59.99		1.667
18. Smalt	0	33.33	66.67		1.5
19. Ultramarine	0	24.98	75.02		1.333
20. Gentian	0	14.31	85.69		1.167
21. INDIGO	0	0	100.00		1
22. Woad	9.09	0	90.91		1.1
23. Violet	16.67	0	83.33		1.2
24. Purple (true)	23.08	0	76.92		1.3
1. Tyrian	28.57	0	71.43		1.4
2. Puocelle	33.33	0	66.67		1.5
3. Mauvure	37.50	0	62.50		1.6
4. Amaranth	41.18	0	58.82		1.7
5. Mulberry	44.44	0	55.56		1.8
6. Rubraocinth	47.37	0	52.63		1.9
7. MAGENTA	50.00	0	50.00		2
8. Cherrose	53.33	0	46.67		1.875
9. Carmine	57.14	0	42.86		1.75
10. Red (true)	61.54	0	38.46		1.625
11. Garnet	66.67	0	33.33		1.5
12. Crimson	72.73	0	27.27		1.375
13. Soarlet	80.00	0	20.00		1.25
14. Cardinal	88.89	0	11.11		1.125
15. VERMILION	100.00	0	0		1
16. Mandarin	85.69	14.31	0		1.167
17. Orange (true)	75.02	24.98	0		1.333
18. Pyridian	66.67	33.33	0		1.5
19. Safran	59.99	40.01	0		1.667
20. Aurise	54.55	45.45	0		1.833
21. YELLOW (true)	50.00	50.00	0		2
22. Flavelle	47.37	52.63	0		1.9
23. Chartreuse	44.44	55.56	0		1.8
24. Mascagna	41.18	58.82	0		1.7

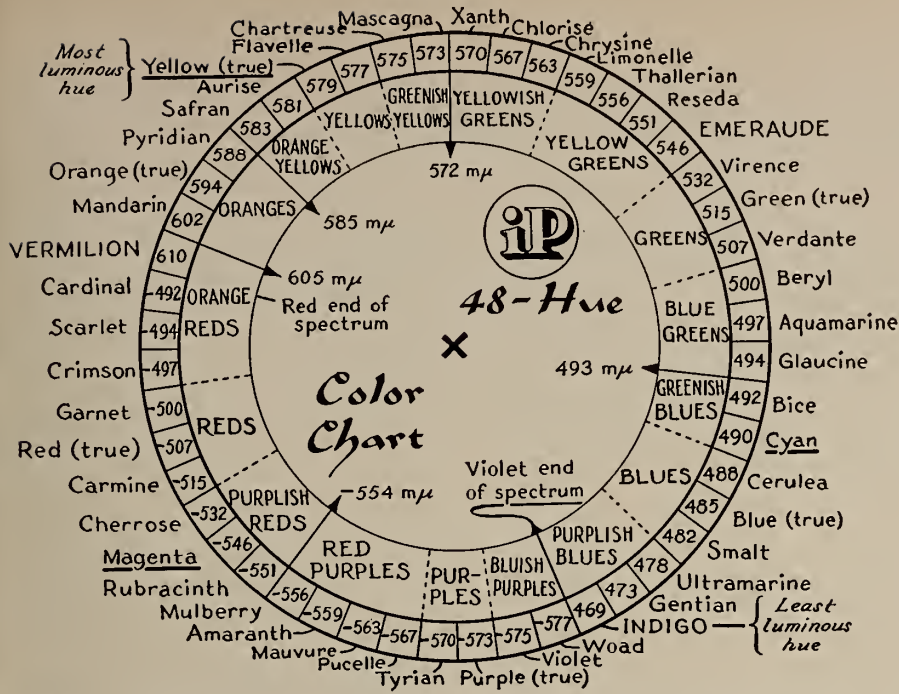

orange. Continuing down the list brings us back to yellow.

Color Filters or Mixed Paints

Table C is useful when we wish to reproduce hues by means of superposed color filters or by mixing paints—a much easier method but less accurate than mixing colored lights.

The values for superposed filters speak for themselves. When the deepest (most saturated) yellow, magenta, and cyan filters are laid on top of each other (100, 100, 100), no light can pass, and the result will be black. Note that the values for any two complementaries add up to black. Equal but lower values for the three filters (as 20, 20, 20) will produce neutral grays.

The percentage values for paints require a word of caution. The Y, M, and C pigments must be adjusted in strength beforehand (by diluting the one or two paints which may be too highly concentrated) so that equal proportions of the three will give a neutral dark gray.

The percentage values in Table C are very different, and vary in a different way, from those in Table B. There is no simple mathematical interrelation between these percentages and the density-proportions used in filter superposition. The matter is further complicated by the fact that the grays produced by mixing two complementary colored paints (with but three exceptions) do not contain equal amounts of yellow, magenta, and cyan.

Compound Colors Additively

This extraordinary state of affairs is due to the fact that the Y, M, and C pigments in the paints consist of small opaque, not transparent, particles, thus forming compound colors additively rather than subtractively. The color-mix-

ing is subtractive in method, to be sure; but the color formation is actually largely additive.

Nor is the mixing of opaque Y, M,

and C pigments the simple, easy-to-understand additive color-formation previously discussed—the mixing of vermilion, emeraude, and indigo lights only two at a time. When two secondary pigments are mixed, three primary components are involved. The resultant color balance is shifted in remarkable, sometimes unpredictable ways.

When a few drops of thick magenta paint and a like amount of thick yellow paint are placed side by side and stirred together with a toothpick to make vermilion, fugitive streaks of green suddenly appear and disappear during the mixing! The green streaks are unmistakable, even though faint.

All these very confusing complications need not concern us. It is enough to bear in mind that yellow, magenta, and cyan paints, and all other types of pigments which are viewed by reflected, rather than by transmitted, light cannot possibly make black when mixed together in equivalent proportions. The result is neutral gray, not black.

Those who wish to experiment with
(Continued on page 30)

TABLE C. SUBTRACTIVE FORMATION OF COLORS

Hue	PRIMARY COMPLEMENTARY COMPONENTS			PRIMARY COMPLEMENTARY COMPONENTS		
	SUPERPOSED FILTERS			OPAQUE PIGMENT MIXTURES		
	Filter Color Density			Proportions in Per Cent		
	Yellow	Magenta	Cyan	Yellow	Magenta	Cyan
1. Xanth	100	0	40	86%	0%	14%
2. Chlorise	100	0	50	80	0	20
3. Chrysine	100	0	60	74	0	26
4. Limonnelle	100	0	70	68	0	32
5. Thallerian	100	0	80	62	0	38
6. Reseda	100	0	90	56	0	44
7. EMERAUDE	100	0	100	50	0	50
8. Virence	87.5	0	100	42	0	58
9. Green	75	0	100	35	0	65
10. Verdante	62.5	0	100	28	0	72
11. Beryl	50	0	100	21	0	79
12. Aquamarine	37.5	0	100	14	0	86
13. Glaucine	25	0	100	7	0	93
14. Bice	12.5	0	100	2	0	98
15. CYAN	0	0	100	0	0	100
16. Cerulea	0	16.7	100	0	4	96
17. Blue	0	33.3	100	0	11	89
18. Smalt	0	50	100	0	19	81
19. Ultramarine	0	66.7	100	0	29	71
20. Gentian	0	83.3	100	0	39	61
21. INDIGO	0	100	100	0	50	50
22. Woad	0	100	90	0	56	44
23. Violet	0	100	80	0	62	38
24. Purple	0	100	70	0	68	32
1. Tyrian	0	100	60	0	74	26
2. Pucelle	0	100	50	0	80	20
3. Mauvure	0	100	40	0	86	14
4. Amaranth	0	100	30	0	91	9
5. Mulberry	0	100	20	0	95	5
6. Rubracinth	0	100	10	0	98	2
7. MAGENTA	0	100	0	0	100	0
8. Cherrrose	12.5	100	0	2	98	0
9. Carmine	25	100	0	7	93	0
10. Red	37.5	100	0	14	86	0
11. Garnet	50	100	0	21	79	0
12. Crimson	62.5	100	0	28	72	0
13. Scarlet	75	100	0	35	65	0
14. Cardinal	87.5	100	0	42	58	0
15. VERMILION	100	100	0	50	50	0
16. Mandarin	100	83.3	0	61	39	0
17. Orange	100	66.7	0	71	29	0
18. Pyridian	100	50	0	81	19	0
19. Safran	100	33.3	0	89	11	0
20. Aurise	100	16.7	0	96	4	0
21. YELLOW	100	0	0	100	0	0
22. Flavelle	100	0	10	98	0	2
23. Chartreuse	100	0	20	95	0	5
24. Mascagna	100	0	30	91	0	9

Rear Projection in the Theater

By J. L. STABLEFORD

REAR projection was probably introduced into early theaters because of structural difficulties. For example, old type music halls, where it was not feasible to build a conventional projection room, were converted to back projection. The screens in such cases usually consisted of cotton.

A cotton sheet will produce a substantial real image by rear projection, but direct rays of light will pass through the weave and completely mar the viewing. Therefore, the cotton was treated with a type of varnish or linseed oil medium, and was even kept continuously wet by dripping water down it.

Judged by modern standards, the picture was unsatisfactory, even when the screen was new. The doping medium rapidly oxidized and collected surface dirt. The actual fibre of the fabric itself having a high refractive index therefore had considerable opacity. Whilst acting as an efficient diffuser, it also acted as an even more efficient absorber or stopping agent.

Another unfortunate characteristic of this type of screen is that it acts as an *efficient front projection screen*; the doping of the fabric somewhat reduces this effect, but the net reflectivity is still substantial, probably of the order of 50%.

Reflectivity of Translucent Screens

If a rear projection screen reflects back towards the incident ray something like half the total available light flux, there is only one-half of this light flux available for useful work. Of this remaining half, about 25% is absorbed by the textile material of the screen. The light that is available to form an image on the front surface of the screen is much attenuated.

A number of theaters have survived in this country to the present day with back projection—somewhere between 30 and 40 out of a total of nearly 5000—but I do not recall any theater which has been designed and built for use with rear projection.

Our greatest sensation of stimuli is received by foveal or central vision, where the acuity is of a very high order. This foveal vision functions over an extremely narrow arc, approximately 1° , and the fact that we appear to see things with great sharpness over a substantial area is due to the fact that the foveal vision is scanning at very high speed the dominating centre of interest. The remaining visual impression is gathered by macular or peripheral vision, which is not sensitive at high brightness levels. However, it has about 16 times the sensi-

One of Europe's leading screen manufacturers, in presenting the accompanying paper before the British Kinematograph Society, makes out a strong case for widespread use of rear projection in the motion picture theater. Existing structures and equipment are a decisive factor against any early move in this direction.

tivity of foveal vision at low brightness levels, to enable us to deal with low levels of illumination.

Objective consideration will suggest that only rarely does acute vision stray to the edge of the screen.

Matte and Beaded Screen

By far the most generally used screen for front projection today is the matte white. This gives a first-class picture over a very wide angle, with a reflection factor of about 0.7. It is rather lacking response in blue and this is accelerated as, with increasing age, it yellows and finally browns, due to the deposition of tobacco tar. This tar exists in astonishingly high concentration in our film theaters.

The glass-beaded screen, the second in general use, also suffers from the latter defect, but its virtue is that it gives a much brighter picture over a narrow angle, refracting and reflecting the ray in the direction of the light source. Thus, it should be used only under appropriate conditions. At the peak of its reflectivity curve, it can give a factor of 2.0 or 3.0, taking 1.0 as the reflecting factor of a 100% perfect diffuser and reflector.

This high response has fallen to 1.0 at about $12\frac{1}{2}^\circ$ or 15° from the normal to the screen, that is, a solid angle of 25° to 30° . The curve is not square-topped but has a sharp apex and falls steeply from the nodal point: it continues, but rather less, steeply, beyond the above angles.

Centre-to-Side Ratio

A matte white front projection screen gives a centre-to-side brightness ratio of about 1.5 : 1 with an average projection system, and it must be admitted that a centre-to-side brightness ratio of 2 : 1 is not so rare nor so objectionable as it would appear. It is true that projection engineers as a rule strive, at great trouble and expense, to produce an illumination over a screen as even as possible, but there are many who consider that a completely even illumination over the whole of the screen is not desirable.

In my experience, a completely even

illumination, even when it is of high brightness, produces a flat and uninteresting picture, and side-by-side test, with two projectors of the latest type, have shown that a picture with 1.5 : 1 or higher centre-to-centre brightness ratio has more sparkle and life than one with 1 : 1 ratio. Indeed, this is very much in accord with our normal sensation of seeing.

There are several fundamentals in which motion picture presentation falls short of nature, *i.e.*, completely natural color; adequate contrast ratio; and method of masking the picture. Stereoscopy is omitted for the reason that it is outside the orbit of this paper.

Completely Natural Color

If in the studio colors are painted in with all the delicacy of nature, it is to be feared that a high proportion of them will be reproduced only as monotone grey. There are two reasons for this.

Frequently the picture is inadequately lit, consequently there is insufficient contrast ratio to generate color in the lowest lights. The spectral response of even a new front projection screen is lacking in blue; as a screen gets dirty, there is a pronounced shift further to the red: it is equivalent to projecting color through a pale yellow filter, then a dark yellow filter, and finally a brown filter.

Contrast Ratio

Front projection screens as used today have been stabilized as to their contrast ratio. Their very efficiency as a reflecting agent limits their capacity for contrast. A picture is produced only by relative brightness; highlights must be produced at such intensity that the screen already illuminated by the house lights appears in the low-lights relatively black.

An efficient back projection screen is a very inefficient front projection screen, so that high orders of maintained house illumination have, consequently, a very reduced capacity to debase or degrade the low lights of the projected picture. This principle is being used in an ever increasing fashion in domestic television, by using a dark filter placed in front of the cathode-ray tube, so reducing the front reflection effect.

Change in Method of Masking

Viewing a motion picture through the encircling frame of a dense black mask is not the manner in which we normally view anything seen in nature. It must produce some jarring effect on the retina, particularly as the motion and changing light value at the edge of the screen, so

abruptly cut off, are in the main viewed by peripheral vision, which is extraordinarily sensitive to movement and low key illumination.

It is obvious that a good deal of unconscious accommodation has to be done by the eye to cope with these conflicting factors. The black mask is a relic of the days when we had insufficient illumination to produce a first-class picture, and subterfuges like this were almost compulsory.

If the black mask were suppressed and the picture gradually merged into the auditorium, less eyestrain would result.

This proposal is introduced herein because, if the suppression of the hard masking is carried out under conditions of back projection, it is thought that colors will appear more water-clear and natural, and particularly the blacks much blacker. The eye will lack the hammering effect of the black border, which does not help quiescent adjustment to the picture it is viewing. It might also be said that the picture will have a spatial effect rather than that of a peep-show.

Studio Rear Projection

Rear projection has been in use for many years in the film studios, although up to about three years ago it had reached a static stage in so far as the screens were concerned, the main developments continuing along the lines of obtaining ever more illumination. Even in the film studios, however, rear projection was looked upon with suspicion. It was used for passing window shots in

train or taxicab scenes and limited to a very small area of the picture. One half of 1% of the whole film footage would probably represent the average use of rear projection up to 1945.

The screens used in the studios were usually made of cellulose acetate, and although a certain amount of experimental work had been done on them, the characteristics were accepted as fairly standardized. Their overwhelming defect was the hot-spot effect.

Some modification of this defect was produced by coating the centre of the screen with an absorbent agent, in order to deaden some of the brightness in that region. This expedient only partially met the trouble, as the extra opacity was effective only from one viewing point. As the studios were concerned only with one viewing point—the lens of the camera—this defect was not of much consequence.

'Independent Frame' System

During 1946, a new conception of film production was envisaged, known as "Independent Frame." One essential requirement of this process was that 80% or even 90% of the film footage was shot with process rear projection, and it will be obvious that the very gravest optical problems had to be faced in embarkment upon such an undertaking.

The essential characteristics of the desirable screen were that it should have no hot-spot from any viewing angle, when viewed with the picture in the gate, and only traces of a hot-spot when viewed with clear projection illumination. It had

to provide a sufficiently even picture over a wide angle so that the camera could pan, zoom or track, and the actors would about in front of the back projection screen without the effect showing in the resultant film. In fact, its characteristics should provide almost the same amount of scope and freedom as given by an orthodox set.

Characteristics of Translucent Screens

Measurements of screen characteristics, which were taken in the experimental work on screens, used as a datum a theoretically perfect lambert surface with a factor of 1.0. The lambert surface readings were taken at the same time as the other curves. Fig. 1 shows such curves. The range varies from a centre brightness 15 times that of the theoretical lambert surface to a 1.5:1 ratio. The latter, however, is very dense and produces an unnecessarily high loss in overall illumination. For normal work, a centre-to-side brightness ratio of between 2 and 3:1 was completely acceptable, and this gives a brightness, as compared with a theoretically perfect lambert surface, of 3 or 4 times.

These are very high orders of efficiency and are probably beyond the scope of any generally used front projection screen material. It must be observed that the best of these screens were capable of producing a standard of quality beyond that required for entertainment purposes, since they had to be photographed by a camera, the film processed, positives made and then reprojected in a theater—all this tending to degrade the definition and quality.

Theater Tests of Screens

As a practical experiment, four theaters which were using back projection, and all of which had for long dissatisfied projection engineers, were selected. No particular screen characteristic was aimed at; what was thought would be a satisfactory screen was tried. It must be said immediately that the resultant picture, from the first showing, produced an astounding effect. On a picture 18 feet wide, the quality and brightness were better than anything seen in the West End (London de-luxe theaters) or elsewhere. There was no sensation of hot-spot, and the coverage from the widest front seats were quite adequate.

An interesting characteristic was the spectral response of the screen. The picture shown on this occasion was "The Red Shoes"—a film which was a distinct step forward in the handling of color as an art. In this film, several of the scenes are shot with the chief actors wearing evening dress, and, as is usual, their shirts were pale blue in color. On normal front projection screens, either matte or beaded, which have a minus-blue reflection

(Continued on page 27)

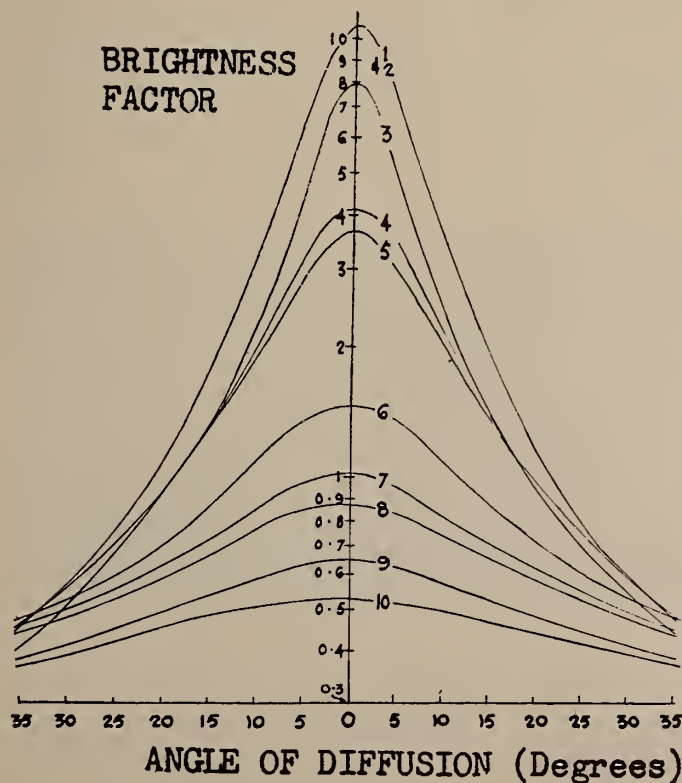

FIGURE 1

Characteristic curves of various types of translucent screens, obtained by the use of different grades and quantities of powdered glass. It will be seen that the range varies from a center brightness 15 times that of the theoretical lambert surface to a 1.5:1 ratio. The latter, however, is very dense and occasions a high loss in overall illumination.

IN THE SPOTLIGHT



By
**HARRY
SHERMAN**

UNDERSCORING the importance attached by Labor to the matter of wage ceilings in an industry where no price ceiling is in effect (such as motion pictures) was the attendance at the recent hearings held by the Wage Stabilization Board in Washington in an attempt to unravel this knotty problem. Labor is unreservedly and unremittingly opposed to any such one-sided situation, its stand being that any leeway extended to industry in the way of exemption from price ceilings should extend to cover the workers therein.

Included among the principal witnesses appearing before the WSB special panel which was set up to decide the question were Frank R. Murdock, general counsel for the IA and Robert W. Gilbert of the AF of L Film Council. The IA counsel laid it flatly on the line:

"In World War II, I was very close to this price and wage picture, as many of you know. At that time there was general compliance. Today, although we have a Korea, we have no Pearl Harbor. Without a Pearl Harbor, we have and will have no voluntary compliance.

"Congress made it quite evident, when it did not include these industries in the price-fixing blanket, that it did not intend them to be brought under any wage ceilings. Our employers are selling and we are producing intangibles. There is talk of hoarding. How can there be hoarding in the amusement field?

"Are people going to see more pictures or more shows because there may not be any more movies or shows? Are prices going to increase beyond what the traffic will bear? How can there possibly be any skyrocketing of wages in our field? We have had to fight for every extra nickel that we have squeezed out of our employers."

This viewpoint seems to us to make sense, not because it gives Labor a break but because it is equitable.

In passing, it might be mentioned that those workers in industries which have price ceilings but whose Labor contracts do not provide for a cost-of-living increase, are in a tough spot. Their employers need only shrug and point their

fingers at the WSB and utter only a single word, "forbidden."

- While we're on the topic of workers' welfare, we offer the following important suggestions anent your Social Security status. Here are a few things that are often neglected in the daily rush. Be sure to tell your family these four things:

1. That you have a Social Security account and that this may mean monthly insurance benefits for your family.

2. Where you keep your S. S. account card.

3. To get in touch with the nearest S. S. office in case of your death.

4. To file their claims promptly so that they may not lose any of their payments.

Also, did you know that if you elect to retire there are *three* kinds of benefits available to you? Or that in case of your death there are *five* kinds of benefits your family may elect to receive? It might be well if all workers familiarized themselves with these various benefits, and with the S. S. formula in general, *right now*. Detailed information is available at your nearest S. S. office.

- All this furor about the effect of Tv on the entertainment field has not de-

tered that old warrior, prexy Jimmy Petrillo of the Musicians, from swinging some nice deals for his men. His latest move was to sign two picture companies, Republic and Monogram, to contracts under which the companies will turn over to the AF of M 5% of all monies realized from the sale of Tv rights to their productions. The agreements run for three years, with all such payments, estimated to run to \$2 million, to go into the union's welfare fund.

Where old Republic and Monogram films are concerned, the agreement provides that they be rescored by AF of M members before exhibition on Tv.

- The Consumers' Price Index, published recently by the U. S. Dept. of Labor, reveals an increase of 9.6% above a year ago in the retail price of goods and services bought by the average moderate-income urban family.

- IA President Dick Walsh attended the dedication service of the Carter Barron Amphitheatre in Washington D. C. last month as a tribute to the late Eastern division manager for Loew's, Inc., who died last November.

- N. Y. City Local 306 has named as its

GALA CELEBRATION MARKS 40TH ANNIVERSARY OF PHILADELPHIA LOCAL 307



Guests at the party included (left to right): Thomas J. Shea, assistant IA president; from Local 307: Abbatt Oliver, vice-president; Horace Johns, business representative; and Harry Abbatt, president of the Local and 8th IA vice-president; Richard F. Walsh, IA president, and William P. Raoul, general secretary-treasurer. Gold life membership cards were presented to the Local 307 officials shown here, while all Local members far 35 years or more received special lapel buttons. Charles Humphries, sec.-treas. of Local 307, did a swell job an arrangements.

general counsel Herman E. Cooper, noted anti-Communist. He replaces Harry Sacher, who was one of the defense counsel for the 11 national officers of the Communist Party whose conviction was recently upheld by the U. S. Supreme Court. Sacher, incidentally, was cited for contempt of court during the trial and must himself serve a jail term.

- We understand that Bill Covert, 2nd IA vice-president and business representative for Toronto Local 173, is busy organizing radio and Tv workers in Canada. This may set off a jurisdictional dispute between the IA and CIO's National Ass'n of Broadcast Engineers and Technicians.

- We regret to have to record the death of Arthur F. Morrone, 71, president of the Superior M. P. Supply Co. in Pittsburgh, Penna. Born in Italy, Art came to this country when he was six. Until he went into business for himself 20-odd years ago, Morrone was a projectionist member of IA Local 171, having been in the industry a total of 45 years. He was also a member of the Variety Club.

- Among the visitors to the IP offices lately were Gus Demery, Local 173, Toronto, and Frank Jiruska, Secretary of Local 191, Cedar Rapids, Iowa.

IA-IP Radio Man of Month



Here is a likeness of Herb Kleinback as he works his amateur radio station W9RTA at Elmhurst, Illinois. A member of IA Local 110, Chicago, Herb has been on the job as projectionist at the Four Star Theater for 32 years. He is not only an outstanding radio "ham," but he is an accomplished musician as well, much of his time being given to giving his three children a thorough grounding in music.

Herb started back in 1908 as a road projectionist. He is more of a CW than a phone man and can copy a solid 35 per. If you want a really interesting QSO, contact W9RTA.

be most appreciated. Please don't publish my name.

LONG-TIME SUBSCRIBER

To the Editor of IP:

During the last few years I have picked up many thousands of feet of 35-mm nitrate film which is composed mostly of outdated trailers for which I have no use. I wonder if you know of anybody who could use this film, possibly for various experiments which IP mentioned.

I would be glad to give this film to anybody who has use for it. I should like an answer on this within a reasonable time, otherwise I will destroy the stock.

GEORGE E. READ

131 Merritt Ave., Syracuse 7, N. Y.

To the Editor of IP:

Here is our remittance for the men on the attached list. The boys all get a great deal out of IP and are extremely pleased with it. I myself have been a subscriber for many years, and having been a visual and sound projection service man in the past. I appreciate the manner in which IP keeps up with the new stuff as it comes out.

ERNEST GOSSERT

Secretary, IA Local 430, Fortuna, Calif.



To the Editor of IP:

I would appreciate any information you can give me relative to a "crackle" which I get in the sound horns behind the screen. This crackling noise shows up when I change over on either machine. This crackling is also audible through the projection room monitor.

The equipment consists of Simplex projectors, RCA soundheads and amplifier, and Brenkert lamphouses. I have audio trouble-shooting charts, but they cite no apparent reason for this particular trouble.

NEW JERSEY PROJECTIONIST

Although akin to treating a human illness by mail, IP will try to help by passing on the appended communication from RCA Service Co.:

From what little information your correspondent has given, the trouble appears to be in the main amplifier system. This type of noise could be caused by a defective tube, leaky condenser, a poor solder connection, or it could be picked up from some outside source, such as a sign flasher, X-ray equipment or motor commutator. Noises of this type have also been known to originate in the arc lamp

relay contacts and other electrical circuits.

The best advice to give this man, if the theater is not on RCA Service, is to have him contact one of our District Service Offices, or one of our Field Engineers, and give the equipment a thorough overhauling. If it is a small theatre and they cannot afford a regular service call, then a demand call can be made. We believe that he would actually be saving time and money by having a qualified engineer go over the equipment.

RCA SERVICE CO., INC.

To the Editor of IP:

Here is a thought for the boys in the craft. Some of our fellows get bad breaks and wind up for prolonged periods in a hospital or a sanitorium. Why can't we more fortunate fellows who have a brother craftsman in such a spot send along a gift subscription to IP so that the man may keep abreast of what's happening in the craft against the time when he is out and active again?

It's not a million-dollar proposition, but I am sure that such a gesture would

Majors' Earnings Hold Up

20TH CENTURY-FOX: For quarter ended March 31 last a net of \$874,776. Film rentals and theater receipts were \$35,866,841, as compared with \$35,689,073 in same quarter a year ago.

RKO THEATRES CORP.: For final operating year as part of RKO production-exhibition setup, a net of \$1,195,577.

WARNER BROTHERS: For the six months ended Feb. 24 last a net of \$3,827,000, as compared with a net of \$5,897,000 for the same period last year. But the company spent \$2,927,000 during the last six-month period to buy 235,300 shares of its own common stock on the N. Y. Stock Exchange.

PARAMOUNT PICTURES CORP. (not to be confused with United Paramount Theaters): For the first quarter of this year ending March 31 a net of \$1,411,000, as compared with a net of \$1,441,000 for the same period last year.

ALLEN B. DuMONT LABS.: For 12 weeks ending March 25 last a net of \$1,022,000, as compared with \$1,967,000 in same period last year. Profit was off 48% although sales advanced 25%. Lower net, it was explained, resulted from increased costs of certain critical materials, higher wage rates, and higher income tax rate. No mention of how much stockpiling was done or of expenditure for expansion, etc.

EASTMAN KODAK CO.: For 12 weeks ending March 25 last a net of \$10,597,009, slightly higher than for same period last year. This despite the fact that sales for this year's quarter jumped about \$35 millions.

GPL's New 16-mm Sprocket-Intermittent

FEW high-precision devices have proved as rugged and reliable as the 35-mm sprocket-type projector intermittent that operates hour on hour, year on year throughout the world. But because these are precision devices, and making them smaller calls for even greater precision, 16-mm equipment has usually been restricted to the less accurate, claw-type intermittent.

Now, General Precision Laboratory has produced a 16-mm sprocket intermittent. It is standard on four of the PA-series projectors developed specifically for use in television studios and theatre television. This new sprocket intermittent provides greater efficiency in light transmission, reduces film wear and damage to a negligible factor, guides the film without abrasion, is easily framed, and is virtually silent.

Many Advantages Cited

With the sprocket intermittent construction, GPL projectors have the following advantages:

LESS FILM WEAR—At least four teeth are engaged in the film at all times. Wrap of film around sprocket relieves the strain on film sprocket shoes; there is a smoother film acceleration during pull-down.

GREATER SCREEN BRIGHTNESS—Smaller width shutter blades can be used, because of faster pull-down and smaller cutoff angle. **FRAMING**: The sprocket is rotated for framing, instead of displacing the aperture plate. This avoids uneven and reduced screen illumination; also avoids readjustment of projector tilt.

SIDE-GUIDING FILM—Film is guided by rotating with flange at intermittent sprocket. It avoids the wear problem of the usual spring-loaded guide shoe. **LONG SERVICE LIFE**—No skip movement, no fast-moving parts; automatic spring take-up for wear of star wheel teeth and cam.

GEAR BOX—Provides oil-bath lubrication, requires less lubricant attendance. Quieter operation due to insulating effect of gear box walls. **EASY REPLACEMENT**—Unit construction permits quick replacement, if necessary. **THREADING**: Sprocket teeth are in the open, always visible for threading.

Design Features of Gear Box

The intermittent is housed in an oil-filled gear box containing a cam, star wheel and synchronizing gears for motor shaft and cam shaft. Three design features insure against oil leakage: the splash system keeps the oil level below the lowest shaft bearing; all bearings are mounted in tandem with oil seals; oil shafts contain oil grooves cut in the reverse direction of shaft rotation.

The input shaft, coupled directly to an A-C motor, is geared to maintain a cam shaft speed of 1440 r.p.m. Other motors and other currents than 60-cycle A-C may be used by substituting gears that will maintain this speed for pull-down of 24 frames per second.

The cam is a hardened steel flange, about the size of a fifty-cent piece, which rotates at right angles to the 12-tooth star wheel. The cam lobe is on the side, or face, of the disc. The major portion of the flange is flat and corresponds to the dwell period of intermittent cycle. The remaining portion of the disc is raised to effect the pull-down. The cam is proportioned to give the film a dwell period of 310 degrees and a pull-down period of 50 degrees.

At each revolution of the cam shaft, one of the 12 teeth of the star wheel is engaged between the cam and annular spring. Since the normal gap is slightly less than the tooth thickness, the tooth presses laterally against the spring and is held there without vibration. Compensation for any wear is automatic in the spring loading.

Fixed Aperture Framing

During 310 degrees of each revolution of the cam, the tooth remains motionless. In the remaining 50 degrees of turn, the star wheel tooth is indexed one-twelfth

of a turn, or 30 degrees, and the next tooth in line engaged.

The intermittent works similarly to 35-mm movements, where framing is accomplished by rotating the intermittent sprocket. Film is moved into register with a fixed aperture. This eliminates two troubles common in most 16-mm projectors.

In the conventional claw-type, the aperture plate is moved up or down to mask the film picture area. But then the projected picture is displaced on the projection screen and requires adjustment of projector tilt. Also, the aperture is moved off the center line of the optical path, resulting in uneven or reduced screen illumination and poorer picture definition.

In the usual construction of 16-mm projectors, the film is guided laterally by means of a leaf spring. It bears against one edge of the film and presses the film against the opposite side of the film channel. Rubbing action is constantly against the same area and eventually results in formation of a groove, which can open splices or possibly tear film. Even padding the guide with a sapphire only delays the groove's appearance. Once the groove is present, it may weaken film guiding because of decrease in spring pressure. There is also a tendency to cock the film if the groove is uneven.

The cam lobe is shaped to give a uni-

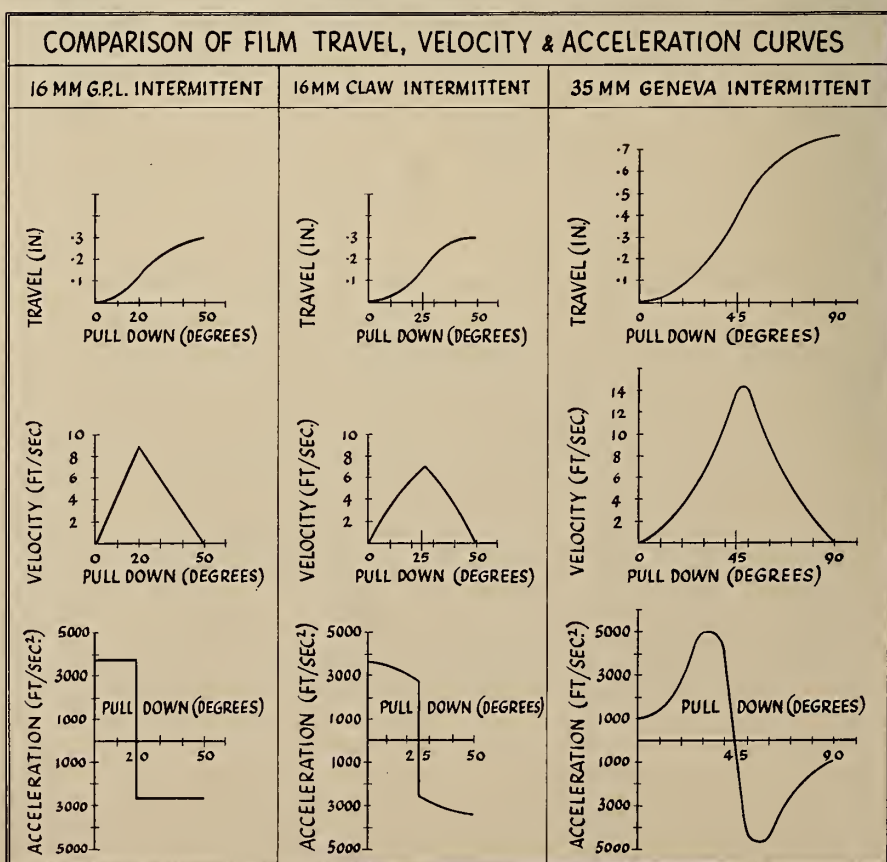

form acceleration for the first 20 degrees of the pull-down, and a uniform deceleration for the last 30 degrees of pull-down. By spreading the deceleration over a longer time interval, the value of deceleration is reduced and in turn permits the use of less film trap drag.

Smaller Shutter Blades

The sprocket intermittent allows the use of smaller width shutter blades than in the usual 16-mm claw movement. Smaller width shutter blades are desirable in that they either increase screen brightness or permit the same screen brightness with less power in the lamp. The width of a shutter blade depends on the size of the pull-down angle and the cutoff angle. The theoretical width of the shutter blade in degrees is equal to the sum of these two angles.

The GPL intermittent sprocket has smaller width shutter blades than claw movements for two reasons: first, it has a faster pull-down angle, 50 degrees as compared to the range from 60 to 90 degrees for the usual claw movement; second, the intermittent operates on the opposite side of the aperture. This allows the shutter to operate in close proximity to the aperture where the light cone is small and the shutter can have a small cutoff angle.

Close Shutter Positioning

The shutter on the GPL 16-mm projector is perhaps closer to the aperture than on any other 16-mm projector. On the other hand, claw movements operate on the same side of the aperture as the shutter. The shutter must be spaced sufficiently away from the aperture in order to avoid interference with the claw. This requires the shutter to operate at a larger cross-section of the light beam and at a larger cutoff angle.

The new sprocket intermittent is used on all GPL projectors: the PA-100 Tv sync projector; the PB-100 portable utility, which has a special cam and shutter arrangement making it possible for an image orthicon Tv camera to pick up the picture without special phasing facilities; and the two arc projectors for theatre use: the 30-amp PB-101, and the 46-amp PB-102.

Top Safety Award to National Carbon

The National Safety Council has granted its highest honor, The Distinguished Service to Safety Award, to National Carbon Co., which firm has reduced employee accident rates each year for four consecutive years. The company's accident rate at 21 plant locations was only one-fourth the 1947-1949 national average for all industries, and slightly over one-half the rate for comparable industries.

Tv Impact on Movie-Going Charted in Mid-West Survey

MORE families owning television sets go to their neighborhood theaters than families without Tv sets, the Minnesota Poll, a sampling organization sponsored by the Minneapolis Star and Tribune, has revealed. The Poll recently completed a study of movie-going habits of Minnesotans based on a carefully prepared sampling of 598 men and women 21 years of age or older, and an analysis of the findings have been made public by the American Newspaper Publishers Ass'n.

Questions on neighborhood theater attendance, however, were asked only in a sampling of the Minneapolis and St. Paul districts. The Poll revealed that 68% of Tv set owners attend neighborhood theaters, while only 52% of non-Tv owners went to neighborhood houses. However, the first runs get a larger attendance from the non-Tv homes—28% of the individuals polled who did not have Tv said they go to downtown houses, and 20% of the set owners said they went to first-run theaters.

As to whether film-going habits change on getting a Tv set. Minnesotans reported as follows: 27% of those having Tv never go to movies, and 14% of those without Tv never go to a theater. Also, it was shown that 80% of those who have sets go less often, and only 35% of those without sets go less often.

Age Is Not a Factor

Age, apparently, is not an important factor in keeping Minnesotans from going to the movies. Only 2% said they were not going to movies because of old age. Only 3% said they couldn't afford to go or thought prices were too high.

Of those Minnesotans who attend movies, 87% receive advance information on the pictures before going to the show. Of this number, 90% said they received their information through newspapers, another 10% got the information by consulting others, 3% got it through previews, 2% by calling the theater, and 9% from miscellaneous sources.

Despite some of the negative factors

CHARTS SHOWING IMPACT OF TV ON MOVIE-GOING HABITS

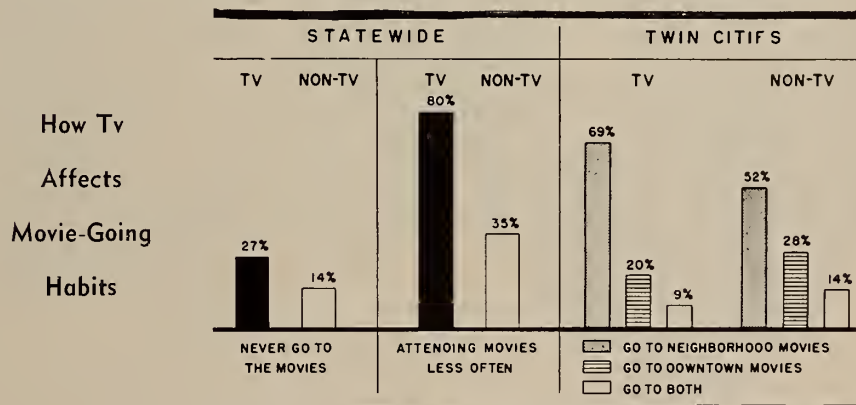

Reasons for Non-Movie Attendance	Twin Cities Area		Outstate	
	Percentage	Percentage	Percentage	Percentage
Television	28%	3%		
Have babies, young children	6%	5%		
Can't afford it--less money for amusements, or prices too high	3%	8%		
Movies aren't so good	5%	6%		
Too busy	3%	6%		
Age; getting old	2%	1%		
Other reasons, or don't know why	11%	11%		
Total	58% **	40% **		

(**--Some gave more than one reason.)

How Information on Movies is Obtained

HOW THE 87% OF PEOPLE WHO SEE ADVANCE INFORMATION BEFORE GOING TO A SHOW GET THE FACTS

NEWSPAPERS	90%	CONSULT OTHERS WHO ATTENDED	10%
PREVIEWS	3%	OTHER SOURCES	9%
CALL THEATRES	2%		

brought out in the poll regarding the Tv impact on theater attendance, there were many bright aspects. The fact that 69% of Tv families go to neighborhood movies was encouraging. This is in direct rebuttal to the position taken by many—in forecasting the future of movies in a Tv world—that it will be the neighborhood house which will suffer most. If four-fifths of St. Paul and Minneapolis Tv set-owners still go to neighborhoods, the prospects for continued good business are bright.

Another encouraging factor was that only 6% of those interviewed out-state

and 5% polled in the Twin Cities gave "movies aren't as good" as Tv as their reason.

New Vallen Catalog Now Available

A new 1951 catalog has been published by Vallen, Inc., Akron, Ohio, firm specializing in the design and construction of curtain controls, tracks and special operating devices. The 15-page catalog, printed in two colors, gives specification and installation data as well as descriptions of the items in the Vallen line. It is available free on request.

NEWS PROJECTIONS

EXHIBITORS squawking that while studios brag about reducing production costs, film rentals, especially percentage pics, continue at the same high level . . . Cinecolor this year will register a 250% increase over last year on its new 2-color process . . . Next two years hold key to the future of the exhibition field, says H. M. Richey, head of Metro's exhib relations. File this under the no-news department . . . No trade show at the TESMA meeting this Fall. Reason: raw material shortages. Incidentally, Oscar Neu, TESMA prexy for the past 18 years, will not be a candidate for reelection . . . Zenith Radio states that its recently concluded Phonevision test in Chicago took in \$1.73 a week per family among the 300 subscribers, or 3½ times the national American family movie-going average . . . The SMPTE is now installed at its new quarters at 40 West 40th St., N. Y. City, 18 . . . So Tv "spot" announcements will help the movie box-office, will they? Well, under existing rates in N. Y. City for Class A time, a minimum campaign involving twenty 20-second-to-one-minute spots, spread over four stations, would cost \$12,000!

Hollywood's production of film exclusively for Tv programs by 27 producers now exceeds the footage turned out for movie theater consumption . . . Another one of those movie theater vs. Tv surveys, This time by Woodbury College, Calif. Announced results: 58% would be willing to pay \$1 for a first-run program on their home Tv set but would not pay the same amount for an exclusive major event on a large screen in a theater . . . 20th Century-Fox will have to divest itself of its theater interests, and National Theaters, its subsidiary, will be forced to relinquish 100 theaters, under the terms of a recent Dept. of Justice order in the anti-trust suit . . . Says Dave Snaper, prexy of New Jersey exhibitors group: "While Lichtman (20th-Fox sales head) was mouthing (to the press) his sentiments about helping to keep theaters open, his New York branch was insisting upon higher rentals for 'On the Riviera' than they have received on any previous picture in recent years."

Reliable estimates place the number of drive-in theaters in the U.S. at 3000. Price war is raging among these exhibitors, the reason being the practice of some drive-ins charging a flat fee per car regardless of the number of occupants, as opposed to per-head charge. Four-wall theaters have joined the drive-in houses

Movies are better than ever! —but how good is the HEART of your theatre?

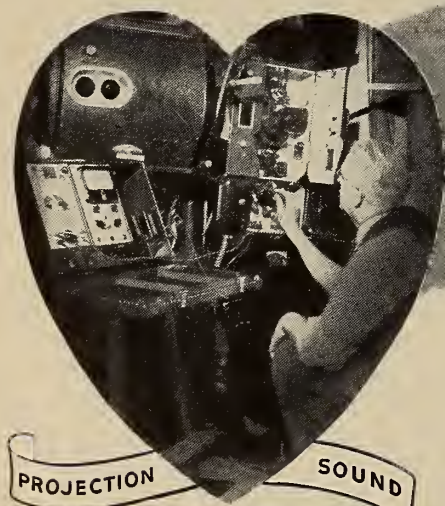

It's good showmanship to make sure that your projection room equipment—the heart of your theatre—operates at peak form . . . at top efficiency. Even with the best-designed and best-made picture projection equipment and sound reproduction system, constant usage causes wear and tear. If not properly maintained, projection room equipment may cause trouble . . . run up costly repair bills . . . result in a "blackout" and loss of box-office receipts.

With RCA Service you can be sure the heart of your theatre is maintained in a thoroughly dependable condition. RCA Service technicians are skilled in the systematic point-to-point checkup and maintenance of all types of projection and sound equipment regardless of make. RCA Service Plans combine expert technical assistance with comprehensive parts and repair provisions for motion picture and theatre TV equipments.

It costs so little to protect so much

The advantages of RCA Service are yours at a cost so low, a few admissions daily pay for it. Write for free folder—"Performance Security."



RCA SERVICE COMPANY, INC.
A RADIO CORPORATION of AMERICA SUBSIDIARY
CAMDEN, NEW JERSEY

supporting the individual charge in protesting to the Internal Revenue Bureau . . . "Unless the televising of college sports events is eventually put on a pay-as-you-see basis, the entire college sports program faces the threat of collapsing," states Bob Hall, athletic director of Yale. He pointed out that more than 72% of the revenue needed for the entire Yale sports program comes from football game receipts, which have been seriously affected by Tv.

The Time is Now!

By NAT GOLDEN

National Production Authority

IF THEATER equipment is obsolete or inefficient and has not been recently modernized, *now* is the time to do it while the equipment is available. Waiting until one can simultaneously remodel his theater may be fatal on the score of losing one's competitive position.

In the past, many theater owners have refrained from modernizing their equipment, particularly projection and sound reproducing equipment, unless they were able to simultaneously do a remodeling or refurbishing job. Apparently, the basis for this is that the theater parton may be unaware of the *equipment replacement*, and in order to appreciate the effort of the theater owner, he must visibly see the type of modernization that is involved, such as in remodeling the front, lobby, auditorium, or rest rooms.

Decrease in Equipment Inevitable

Now that such remodeling is limited to the degree where in many instances nothing can be accomplished, the theater owner inherently eliminates from his plans equipment replacement. This policy, we feel, is most short-sighted.

As the defense program accelerates, the production of 35-mm motion picture equipment must inevitably decrease. Thus, it may not be as easy to replace equipment six or eight months from now as it is at the present time. How long this program will continue is, of course, unknown, because it depends on world affairs.

Theater owners are, therefore, strongly urged, as are other segments of industry now, to launch their modernizing programs immediately.

LOCAL 1, NEW YORK, N. Y.

Election results: Vincent Jacobi, *pres.*; George Fitzgerald, *vice-pres.*; John C. McDowell, *sec.*; John J. Garvey, *treas.*; Solly Pernick and John Goodson, *bus. reps.*; Louis Yeager, *Tv. organizer*; John McCarthy, *sgt.-at-arms*; Joseph Hughes, *replacement committee*.



when you use
SUPER-SNAPLITE

f/1.9 projection lenses

Yes "MOVIES ARE BETTER" and they're "BETTER THAN EVER" if you use Super Snaplite f/1.9 Projection Lenses. These superb lenses give you maximum light, maximum sharpness, and maximum contrast . . . maximum viewing satisfaction for your patrons.

True speed of f/1.9 in every focal length up to 7 inches.
Ask for Bulletins 207 and 209.



"You Get More Light with Super Snaplite"

KOLLMORGEN
2 Franklin Avenue
Brooklyn 11, New York
Optical CORPORATION

Film Projection in Israel

By A. ZEHNGEBOTH

Chief, Zlil Theater, Jaffa

IN ISRAEL, nearly all employees of both film and the legitimate theaters, including actors, are organized as a section of the Histadruth (General Federation of Labor), which not only negotiates for wages and working conditions but also conducts examinations for competency, notably that of projectionists.

Wages would correspond to approximately \$300 monthly for a first projec-

tionist or cashier, and about \$225 for ushers. Payday is every four weeks, including two weeks vacation annually with pay. We give three shows daily for six days of the week, with two evening shows off each week. All previews and extra shows are paid for separately.

Except for one theater now being constructed by 20th Century-Fox, all movie theaters are privately owned, some of them by cooperatives whose members do all the work themselves. I myself belong to such a cooperative of disabled veterans. Being both owners and employees, we are in the unique position of being

members of both the Cinema Owners Association and the Federation of Labor.

In the bigger towns, tickets sell for about \$1, with 40% of this amount going for municipal and Government taxes. Film theaters are overcrowded: in Tel Aviv, for example, there are only 10 theaters with 14,000 seats to accommodate a population of 1¼ million.

Varied Projection Equipment

Throughout Israel there are about 120 film theaters equipped with 35-mm projectors. There are many Ernemann (German-made) projectors, some of the newer type with water-cooled gates, and not a few which have served well for 17 years. British Kallee also has quite a number of installations; but there are few American makes.

We also have about 200 16-mm theaters in small settlements, with most of the projectors being either Bell & Howell or RCA. We use many American-made speakers, rectifier bulbs and carbons, the latter being difficult to obtain. Since we have no very large theaters, or drive-ins, our arc current seldom passes the 60-ampere level. American-made films predominate.

Each producer affiliated with the distributor's organization maintains his own office and facilities for circulating films. The theater receives its film in tins, never on reels. The inspection of film by the distributors is very lax with repairs seldom being made.

Distributors are always straining to squeeze a few more runs out of a poor print, and projectionists must be especially vigilant to spot and repair film deficiencies. In fact, it is due solely to the efforts of projectionists that we have not had a serious film fire for years.

ANSWER TO YOUR TECHNICAL PROBLEMS...



The
Altec
Service
Man

*The Altec
Service Man and
the organization
behind him*



161 Sixth Avenue,
New York 13, N. Y.

PROTECTING THE THEATRE—FIRST PLACE IN ENTERTAINMENT

CLAYTON BALL-BEARING EVEN TENSION TAKE-UPS

For all projectors and sound equipments

All take-ups wind film on 2, 4 and 5 inch hub reels.

Silent Chain Drives

THE CLAYTON REWINDER

For perfect rewinding on 2000-foot reels.

CLAYTON PRODUCTS CO.

31-45 Tibbett Avenue

New York 63, N. Y.

We See Upside Down

WHEN a simple lens casts an image, the image is reversed both up and down and side to side. Use the lens of an ordinary reading glass to throw an image of a lamp on a sheet of paper, or look at the image on the ground glass screen of a camera, and see that this is true.

The eye is often compared with a camera, and rightly so. Like a camera, the eye has a lens system that bends the entering light, forming an image of what is seen on the retina, or sensitive back surface of the eyeball. The pupil—the round opening at the front of the eye—controls the amount of light that enters, just as the diaphragm of a camera lens does.

If the eye acts like a miniature camera, then the image on the retina must be upside down. Why, then, do we not see things turned wrong way up—chandeliers sprouting from the floor and

chairs and tables hanging from the ceiling? The reason is that from earliest infancy we have learned to interpret the upside down images as being upright.

A Simple Experiment

Here is a little experiment to convince yourself that the retinal images are really upside down. Hold a pencil a few inches from a piece of paper lying on your desk so that a lamp casts a shadow of the pencil on the paper. If you now hold a reading glass just below the pencil, the lens cannot reverse or otherwise change the shadow because the pencil is too close to it.

Now do the same thing, using your eye in place of the reading glass: stick a hole in a card with a pin, holding the perforated card about half an inch in front of one eye, and look at a bright surface such as a lighted lampshade or the sky. Grasping the pin by its point, hold it between card and eye and move its head upward in front of the hole. What you see is a shadow picture of the pin moving downward across the hole. We know from the reading glass experiment that the shadow on the retina is right side up; your brain, however, interprets it as being upside down!

Electronic Materials Shortages

Following a discussion by industry representatives anent availability of materials for electronics equipment, NPA officials indicated a continuing tight situation in the following:

Tungsten: There is little relief in sight despite a plan under consideration to purchase additional supplies abroad. A considerable reduction is expected in the amount of tungsten available during July and August. NPA said the industry could assist in meeting defense needs by providing a program of estimated requirements for the remainder of 1951 and for all of 1952.

Cobalt: The future picture for cobalt is somewhat brighter than for tungsten, despite the industry's report of growing shortages of products using cobalt.

Nickel: Little immediate relief is to be

expected, although CMP procedures should ease the situation to some extent for the electronics industry.

Fine Wire: Although there is no immediate problem in fine wire drawing production, tube programs for radar and other military and essential industrial uses probably will create shortages.

NPA's Controlled Materials Plan

Under Controlled Materials Plan, effective in the third quarter of 1951, all manufacturers of motion picture-photographic products (equipment, accessories and motion pictures) are required to submit during the month of May their requirements on CMP 4B forms, the NPA announced. NPA will soon make an announcement on the rules, regulations and procedures to be followed with respect to the Controlled Materials Plan, and the various forms involved.

PERSONNEL

WALTER W. SIMONS, sound picture pioneer first with Vitaphone, then with ERPI, and then with Altec Service Corp. for many years, is now associated with Altec Lansing Corp., Beverly Hills, Calif.

W. F. KELLEY, secretary-treasurer of the Motion Picture Research Council, Hollywood, has been awarded a certificate of service by the American Standards Assoc. for his contribution to the development of American Standards.

FRED WHITNEY, formerly with Altec and ERPI, has joined the SMPTE staff to oversee test film technical operations. A formal quality control program will insure consistently high quality in the SMPTE test films, which are largely responsible for the present high level of quality of reproducing equipment in the 35- and 16-mm fields.

JOHN R. COLEMAN and **DR. L. C. FAULKENBERRY** have been appointed assistant superintendents in the film emulsion coating division of Eastman Kodak.

NEVER HAS

Economy
BEEN SO
ESSENTIAL AS NOW!

THERE IS A LORRAINE CARBON TAILORED FOR YOUR SPECIFIC PROJECTION REQUIREMENT

Send necessary projection equipment data to guide us in recommending the Lorraine Carbons that will do your theatre or drive-in projection job better and More Economically.

SLOW BURNING

SAVINGS IN POWER CONSUMPTION

SAVINGS IN MAINTENANCE

ECONOMIZE

WITH *Lorraine Carbons*

Lorraine CARBONS, INC., BOONTON, N. J.

Now! Get the
Perfect Splice!

with

New-Zip

THE NEW
WIRE-BRUSH SCRAPER

Perfect For The New Safety Stock

Zip goes the emulsion and off goes the binder. The sharp hardened steel scraper blade does part of the job—and the spring steel brush does the rest, roughing up and fogging the base for proper cement penetration.

A Must For Every Projectionist . . .
Use With Your Present Splicer.

New-Zip



Buy your Neu-Zip scraper from your favorite dealer. He has them on display. Just pick yours off the card, and your splicing worries are over.

Recommended by Eastman
Used in Major Exchanges

Est.
1916

TRADE MARK
Neumade

PRODUCTS CORP.
330 W. 42nd St., New York 18, N. Y.

The 'Neu-Zip' Combo Film Scraper for Safety Film



Wrong

Correct

FIGURE 1

The ever-increasing use of safety film has occasioned the development of a new combination wire brush-scraper blade device for use in splicing film. This new unit, known as "Neu-Zip" and developed by Neumade Products Corp., is now available at the very low price of \$2.95 through all theater supply dealers.

Neu-Zip was developed at the suggestion of film handlers of long experience in theaters and exchanges, who found that there is an essential difference between nitrate and safety stock. In the latter, there is a binder between the base and the photographic emulsion which is tough and glossy, making proper splicing more difficult than with nitrate film.

The Neu-Zip combines the conventional scraper blade with a stiff wire brush, both of which are used on the film. After scraping with the blade, a flick or two with the wire brush across the area to be spliced removes all traces of the emulsion and the binder and "fogs" the base to allow film cement to penetrate and make a perfect weld.

Before using Neu-Zip a minor adjustment of the splicer is necessary. For example, on the Griswold splicer the cement guard is a fraction of an inch

away from the scraping blade. This guard on the upper left jaw should be moved

FIGURE 2

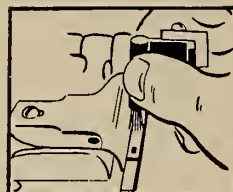

to the right so that it comes just barely to the edge of the blade, as shown in Fig. 1. In Fig. 2 is shown the use of the wire brush so that the film has the frosty appearance shown in the right-hand section.

If desired, both the emulsion and the binder may be removed by the use of the steel brush alone. To clean the brush and restore to original shape requires only a simple twisting between the thumb and forefinger. The unit, individually boxed with instruction sheet, is recommended by Eastman Kodak Co.

U.S. Air Force Stereo Color Film

A three-dimensional color process invented by Maj. Robert V. Bernier, Air Force, employs a single film, requires some alteration of the projector, and spectators wear Polaroid glasses. The Air Force has taken out patents in Major Bernier's name.

Process, in development for 16 years, employs a system of alternate frames to eliminate projection of a second film,

while a revolving shutter with alternate concave and convex mirrors is attached to the projector. 16-mm color film is used.

A Sprocketless Developer

A SPROCKETLESS developing machine for motion picture film has been developed in Europe in which the film in a flattened helical path is carried on racks whose single upper and lower rollers have neither flanges nor sprocket teeth. Overlapping of adjacent strands of film is prevented by fixed separator fingers at the sides of the rack where the film approaches the rollers.

Swelling and shrinkage of the film are accommodated by a change in effective roller diameter in response to tension in the film strands. It is said this machine can be converted from 35- to 16-mm film merely by changing the strand-spacing fingers, with a corresponding increase in film capacity. Alternatively, 16-mm film can be spliced to 35-mm and permitted to follow it through the machine with mechanical adjustment.

French Lenticular Film System

THE LENTICULAR color film process employing a lenticular positive has been revived in France under the name "Opticolor" by the Société Civile de Recherches Scientifiques B.L.V.

The problem of printing from a lenticular negative is avoided by making three color-separation negatives simultaneously in a beam-splitting camera provided with a prism block and three lenses working at an aperture of F:2, and of variable focus from 30 to 68 mm. A special printer has been developed in which the three separation images are printed on a lenticular positive film having 30 minute lenses to the mm. in the picture area only.

RCA and NBC joined in urging the FCC to take immediate steps to lift the Tv "freeze" and permit new stations. Considering the amount of critical materials which go into Tv stations and transmitters, no less than the tough attitude of NPA, the bid likely will fail.

Your Very Best Buy
BUY U. S. SAVINGS BONDS

ONLY Century PROJECTORS HAVE EVERYTHING

- 4-inch diam. lens mount
- Water-cooled apertures
- Oil-less Bearings

CENTURY'S high-efficiency projector with the NEW 4-inch diam. lens provides pictures of increased brightness and appeal—for even the largest drive-in screens.

CENTURY'S water-cooled aperture gives as much light with a 90 ampere arc as other projectors using a 180 ampere arc and heat filters!—Reduce power cost—Get sharper pictures—Save film.

CENTURY'S sealed, oil-less bearings and glass-hard gears reduce maintenance costs. No oil sprays or baths to mess up film or projection room.

You can SEE and HEAR the difference!

CENTURY PROJECTION AND SOUND SYSTEMS
See your dealer or write for information

CENTURY PROJECTOR CORPORATION
New York, N. Y.

REAR PROJECTION

(Continued from page 17)

tivity, these are reflected as a clear white. On the back projection screen, they were reproduced quite distinctly as pale blue, although it is doubtful if the ordinary patrons noticed this particular characteristic.

Practical Factors of Rear Projection

Some of the more practical factors in using back projection will now be dealt with.

During a busy evening, a film theater loses a high proportion of its picture illumination through scattering of the rays, both incident and reflected, in the dense tobacco haze. In foggy weather this effect is increased, and under bad conditions the loss of light arriving in the retina of the patron can be as high as 40%. More than half of this loss can be saved by back projection—that is, the whole of loss in the incident ray, and shall we say that in the reflected ray. This is no mean attraction.

Again, it must be confessed that light scattered from the incident ray is most irritating to a patron sitting beneath it. Without any apparent loss of picture quality, it would be possible to increase greatly the maintained house lighting.

The location of the projection room brings in a number of important factors, the most important of which is the length of throw. If we take a 2-inch lens as a datum, a 20-foot picture needs a 48-foot throw. This is an inconvenient length to find and cloak with a tunnel.

Projection by Mirror

The most obvious answer to this is to fold the ray once by means of a mirror, the projection room being placed immediately under the stage, where it could be housed conveniently as a suite. The ray would be projected from a point as near to the bottom picture line as feasible, upon a mirror placed approximately half-way along the throw. This would necessitate a 10-foot plate-glass mirror. The use of a mirror would not produce any noticeable loss of definition. The weak "ghost" image from the front surface of the mirror, if the latter were of 1/4-inch plate glass, would be so near the main image that probably it would be separated by less than the grain size of the film stock, as magnified on the screen.

The mirror would cause a loss of light of between 9 and 12%, according to its

state of cleanliness, but this would be more than offset by the increased T-value of the longer focal lens, which the double throw permitted. There is an additional advantage in using a mirror: the projector could be threaded with the film the normal way round and not laced back to front or, as has been the usual practice, the picture reversed through a prism.

Life Expectancy of Screens

The type of rear projection screens we are discussing seem to have a life of three years or more, depending very largely upon missiles projected by young patrons. Unfortunately, they are very ex-

pensive screens to produce, so that amortized over a period of three years, the standing charges are somewhat higher than those for front projection, although it is thought that part of the expense might be saved by alleviation of resurfacing costs.

Insufficient experience has been gained in the use of such screens in the theater



THE OPERATORS' FAVORITE!

Golde's Automatic Enclosed Rewind Always Works! Silent, safe, U.L. approved! Eliminates fire hazard. Positive friction... can't clinch film. Tilt-back case... reels can't fly off. Microswitch safety cut-off... when door opens or film breaks, motor stops!

AT BETTER THEATRE SUPPLY DEALERS
GOLDE MANUFACTURING COMPANY
 1222-P. WEST MADISON STREET • CHICAGO 7, ILLINOIS



• The NEW, improved, positive method of permanently patching all types and makes of film—8mm., 16mm., 35mm., Tru-Kolor, Technicolor, Kodachrome, Nitrate and Safety Film.



Used and endorsed by Projectionists in countless theaters.

specifically for *lasting Patches.*

ESSANNAY ELECTRIC MANUFACTURING CO.
 1438 North Clark Street Chicago 10, Illinois

NATIONAL HAS EVERYTHING FOR THE PROJECTION ROOM

Get it from National!

NATIONAL

THEATRE SUPPLY

Division of National • Simplex • Bludworth, Inc.

FOR THE PROJECTION ROOM

29 BRANCHES • COAST TO COAST

BUY U. S. SAVINGS BONDS

Your Very Best Buy

BUY U. S. SAVINGS BONDS

to know the maintenance problems, although it can be said that in the film studios they are washed regularly with soap and water. The inevitable deposition of tar will not have such a disastrous effect upon them as it has upon a matte white screen or a beaded screen.

A matte white screen is a reflecting agent by reason of the white particles of its makeup (omitting the more technical cause and effect). If these particles are impregnated with a brown staining agent, such as tobacco tar, their very capacity to reflect has been destroyed to the ex-

tent of the color to which they have been stained.

If a translucent type of screen is stained to the same degree, its inherent capacity for transmission of light has not been destroyed at all. All that has happened is that a transparent filter, from the deposition of tobacco tar, forms on its surface.

Effect of Increased Brightness

If by increased brightness visual acuity is stimulated, then the magnification factor can be reduced. This is aptly illustrated when one views an object under

a reading lamp for closer examination: the acuity increases, and as the viewing distance or magnification is left unchanged, the sight stimulus is increased.

The inference is that the increased brightness and increased acuity which the back projection screen can provide could lead to a substantial reduction in picture size without loss of visual sensation.

A smaller picture will improve the viewing conditions and sightline problems in almost all theatres, although it is not suggested that any wholesale reduction in size be contemplated. As an illustration of what must be the extreme in this, a special high reflection type of screen using a 20-foot picture was being tested. When showing a richly colored scene under starlight conditions, a group of experienced theater controllers and technicians were able to see an acceptable picture at 1800 feet viewing distance. This is the unbelievable ratio of 90:1.

Sound Reproduction

There is one final aspect of rear projection that must be mentioned, but on which no opinion will be passed, and that is sound reproduction. Obviously, one cannot have a perforated rear projection screen, and sound must therefore be disseminated from outside the screen periphery. Standard practice nowadays is to put the high-frequency speakers above the centre of the screen, and the low-frequency speakers on either side, all three radiating through the wool masking. Theater engineers who service such theaters have reported that they receive no complaints on sound and that, in their opinion, this arrangement is a workable one.

[The advantages of back-projection were the subject of a number of demonstrations. Two identical 16-mm projectors ran matched prints side by side, one with front and the other back projection, the latter showing a marked superiority in brightness and contrast ratio. On a 2 ft. screen, a picture was shown to be of adequate entertainment value at a distance of 30 ft.—a ratio of 15:1. Another demonstration showed that the use of a mirror in the beam caused no perceptible loss of definition. The small effect of ambient lighting was also shown.]

SUPPLEMENTARY DISCUSSION

Q: I believe there are considerable mechanical difficulties to be overcome in sound head construction for rear projection. The question of speaker placement is very important in view of the possibility of stereophonic sound; maybe the last place we want the sound is in the centre of the picture.

A: I think a mirror is essential, when the film can be laced up the normal way.

Q: Rear projection screens at the mo-

WENZEL PROJECTOR CO.

Manufacturers of Many Types of

FILM REWINDERS

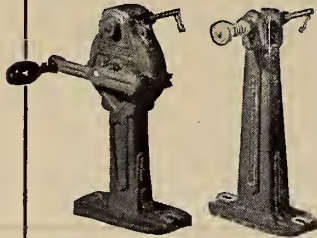

8 M/M
16 M/M
35 M/M
Film

Write for
Illustrated
Brochure

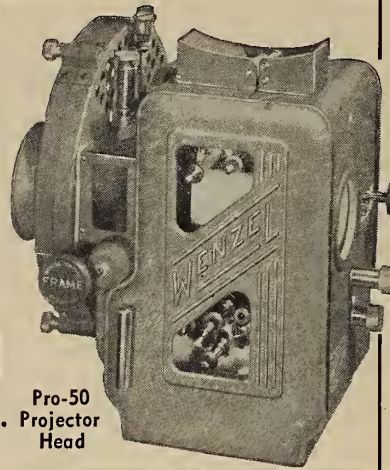

WENZEL PROJECTOR CO.

2505-19 S. State St.

Chicago 16, Ill.

Pro-50
Projector
Head

EFFICIENT • DEPENDABLE

RECTIFIERS

for Every Type Projection Lamp

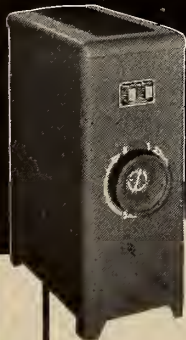

2-Tube
4-Tube
6-Tube

Single and
Three Phase
Models for

- Rotating Feed Angular Trim High Intensity
- Copper Coated Coaxial High Intensity

- 1 K.W. High Intensity
- Low Intensity

Smooth Output Current • Long Life
Low Operating Temperature
Flexibility in Control

Write today for literature or free demonstration.

**THE STRONG
ELECTRIC CORP.**

31 CITY PARK AVENUE
TOLEDO 2, OHIO

PROJECTION LAMPS • RECTIFIERS
SPOTLIGHTS • REFLECTORS



*So much more
than Gears...*

THESE

SUPER
LaVezzi
SERVICE

GEARS!

They are the ultimate in precision manufacture—made by highly skilled operators using newest, most modern equipment. Identical, completely interchangeable—they save time, trouble, expense, assure smoother operation and better pictures.

LAVEZZI MACHINE WORKS

4625 WEST LAKE STREET
CHICAGO 44, ILLINOIS



ment have sometimes a centre-to-side ratio of 4 or 5 to 1.

A: The curve relating to the new screen is appreciably flatter. In the studio, we worked at an angle of 60°, and did not get more than a 2 to 1 brightness ratio. At this angle a beaded screen would show about 5 to 1.

Hot Spot Eliminated?

Q: Do I understand that the travelling hot-spot has been eliminated with this type of screen?

A: With an open gate you can just see the increased brightness in the centre. But when there is a picture in the gate, nobody would see any change in the light.

Q: Could we have further elaboration on the maintenance of rear projection screens? This seems to be the main source of trouble with back-projection.

Favorable Life Characteristics

A: The old rear projection screen had a cotton base, doped with some secret formula. Almost inevitably these screens oxidized and collected surface dirt, and the problem of cleaning was quite out of the question. When reasonably dry dopes were introduced, the problem of cleaning could be approached, but oxidation—the inevitable fall-off opacity effect—went on. The new screen has no cotton base,

and the formula of the plastic can be designed to be as nearly as possible light-fast. The life from the point of view of the maintenance of picture brightness is a very good one. The deposit of surface dirt is the same, but it is an astonishing fact that the tar deposit does not deteriorate the light value of the screen to any marked degree. The life of the screen appears to be limited by the activities of the small boy.

Q: Do you agree that it is impossible to clean any type of screen in the theater?

A: I agree that it is very difficult.

Q: Our experience is that after two years, the deterioration of the screen is much less than we should get with the ordinary front projection screen in six months. One of our control people—who is no technician—was so impressed that when he was transferred to another area I received a note asking me to transfer all his theaters from front to rear projection.

A: The reason a front projection screen turns yellow quicker than a front projection screen is that it is perforated.

Q: What would be the effect on reproduction by the screen in daylight?

A: Under daylight conditions you would not hope to get a picture with a matte screen; you would get a slight picture with a beaded or silver screen. But with a back-projection screen you would get a picture provided it is hooded to keep light rays off the front of the screen, and that no stray light struck the rear of the screen. The front-projection efficiency of a back-projection screen is of the order of .25, as compared with .7 with a matte screen. With the beaded screen the efficiency of 3 to 1 would kill the possibility of daylight projection.

Enhanced Showmanship

Q: From the point of showmanship there are two factors in back-projection. One is that the beam is invisible, the second that the picture is covered by the tabs as they close.

A: Prior to 1945 all studio screens were of American make. They had a centre-to-side brightness ratio of from 12 to 20 to 1. Efforts were made by Hollywood to produce screens for the Independent Frame process, but they never got away from the hot-spot.

Q: Do you consider that putting glass beads on the surface of the translucent screen would help? The Translux people do it.

A: It has some effect on the characteristics, but it is so much bound up with the problems of size of bead, how they are bonded, the depth to which they are embedded, and what other diffusing methods are used.

PROJECTIONISTS FIND CURE FOR "CURTAIN IRRITATION"

No patent medicine will cure the sinking feeling projectionists get when they push the curtain button to start a show—and nothing happens.

That kind of "all-gone" feeling (which makes projectionists grow old before their time) requires a strong remedy—a remedy that consists of curtain controls, tracks and special operating devices that work properly all the time.

Specifically, it calls for Vallen equipment. For 35 years the products of Vallen precision engineering have served projectionists all over the world faithfully and well. The superior design and construction of Vallen curtain controls, tracks and special operating devices makes them all-time favorites of the men behind the show.

To make certain the front office sees eye-to-eye with them on this important subject, wise projectionists are putting copies of the latest Vallen catalog on their bosses' desks. You can do the same. Write today to

VALLEN, INC., Akron 4, Ohio.



Stop

BEING A CARBON WASTER

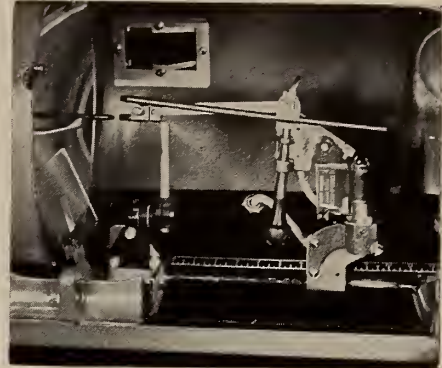

THE CRON-O-MATIC Fully Automatic CARBON SAVER

uses up stubs of all lengths. No preparation required. Simply insert in the holder.

In no way interferes with the regular operation of the lamp.

Cuts Carbon Costs 25%

Conserves your supply of carbons with the heavier copper coating.

Adaptable to Ashcraft "D", Brenkert-Enarc, Peerless Magnarc and Strong Mogul lamps.

Only \$52.50. Quickly pays for itself . . . then goes on to make money for you.

- SOLD BY
- | | |
|------------------------|------------------------|
| ALBANY, N. Y. | DENVER, COLO. |
| National Theatre Sup. | National Theatre Sup. |
| ATLANTA, GA. | JACKSONVILLE, FLA. |
| Southeastern Theatre | Southeastern Theatre |
| Equipment Co. | Equipment Co. |
| BOSTON, MASS. | KANSAS CITY, MO. |
| Joe Cifre, Inc. | Shreve Theatre Supply |
| BUFFALO, N. Y. | Stebbins Theatre |
| Eastern Theatre Supply | Equipment |
| Co., Inc. | MEMPHIS, TENN. |
| CHARLESTON, W. VA. | Monarch Theatre Sup- |
| Charleston Theatre | ply Co., Inc. |
| Supply | National Theatre Sup. |
| CHARLOTTE, N. C. | NEW ORLEANS, LA. |
| Southeastern Theatre | Southeastern Theatre |
| Equipment Co. | Equipment Co. |
| CINCINNATI, OHIO | PITTSBURGH, PA. |
| Midwest Theatre Sup- | Atlas Theatre Supply |
| ply Co. | SALT LAKE CITY, UTAH |
| DALLAS, TEX. | Service Theatre Supply |
| Hardin Theatre Supply | Co. |
| Co. | SAN FRANCISCO, CAL. |
| Southwestern Theatre | Western Theatre Sup. |
| Equipment Co. | |

If your theatre equipment dealer cannot supply you, order direct.

PAYNE PRODUCTS COMPANY

Cron-O-Matic Division

2454 W. Stadium Blvd., Ann Arbor, Mich.

- () Please send free literature on Cron-O-Matic Carbon Saver.
 () Please ship Cron-O-Matic Carbon Saver, () C.O.D., including postage.
 () Remittance herewith.

NAME
 THEATRE
 STREET
 CITY & STATE

Dealer Inquiries Invited

Export: Frazar & Hansen, Ltd.
 San Francisco, New York, Los Angeles

THE MAGIC OF COLOR

(Continued from page 15)

colored pigments will find the following show-card water paints both satisfactory and inexpensive:

YELLOW: Carter's "Tempera" *Yellow*.
MAGENTA: Derayco "Poster" *Brilliant Magenta*.

CYAN: Carter's "Tempera" *Turquoise Blue*.

A knowledge of primary and secondary colors and the in-between hues is necessary for a perfect understanding of the various processes of motion picture color photography, film processing, and projection—topics to be discussed later in this series of articles. But now that the *saturated* colors and the additive and subtractive methods of producing them have been described, colors which are *not* saturated warrant a few words. Brown, maroon, salmon, olive, pink, lavender, flesh, and slate are examples of unsaturated colors. None of these can be found in any hue chart.

What happens when white paint is added to pure magenta paint, or white light mixed with magenta light? The resulting color is rose-pink. And when black paint is added to magenta paint, or magenta light reduced in intensity? Maroon, a purplish brown, is obtained.

In both cases the saturation of the magenta has been reduced. Pink is a *tint* of magenta, and maroon is a *shade* of magenta. Pink and maroon both have the same *dominant hue*.

The same applies to the tint "tan" and the shade "brown." Orange is the dominant hue of both. Tints of the yellow-greens are the apple- and fern-greens; shades of these hues are the olive-greens and russets.

'Shades' of Tints

In addition to these simple tints and shades we find *shades of tints*. These are the tinted grays. By adding a small quantity of black to "baby blue" (a tint of blue), slate results. And by adding black to pink (a tint of magenta), we get a rosy gray called ash-rose.

When the eye has been educated to an appreciation of these delicate unsaturated colors, observation will reveal that many of the objects which are commonly described as white, gray, or black actually possess hue. "White" clay may be bluish, yellowish, or reddish, *etc.* A "gray" stone may be perceptibly violet. A "black" lump of coal may show green, blue, and brown variegations.

Also, the "native" colors of things—the colors which things actually possess—are profoundly affected by the color of the light which illuminates them. Fresh snow is the whitest, the most nearly hueless, substance in nature. But in the light of the setting sun snow ac-

quires various red, orange, and yellow hues; and in shadows, where it receives light only from the sky directly overhead, snow is distinctly blue.

A complete cataloguing of colors is fortunately by no means as complicated as might be thought. It has been claimed that the human eye is able to discern a total of 2,000,000 separate colors; but this overwhelming estimate is greatly in error. To be sure, photometric devices have been made which can differentiate 2,000,000 colors. Human vision, however, does well to distinguish 1/1000 of this number.

The truth of the matter is revealed by IP's 48-hue color chart (Fig. 3). By maintaining the equal-sensation unit intervals of this chart throughout a complete color scheme of unsaturated colors, the total number of colors (including the 48 saturated colors and 13 tones of neutral gray in addition to black and white) comes out to be approximately 400.

This estimate represents all the colors and tones which can be *easily* distinguished from one another by normal vision. The very best natural-color photographic processes are unable to reproduce even half this number.

The total number of colors distinguishable from one another by normal vision is from 4 to 5 times the number which can be derived from the IP 48-hue scale; that is, from 1600 to 2000 colors including neutral tones. Only very exceptional individuals can differentiate more than 2000 colors.

[TO BE CONTINUED]

Westrex Magnetic Recorder

Westrex Corp. has announced and presented demonstrations of its new 1951 Series 1100 standard magnetic recording systems. These systems are fixed studio or portable location recording equipments for the use of 35-mm, 17½-mm or 16-mm magnetic film.

Each complete system includes two dynamic microphones, a microphone floor stand, a 2-position mixer-transmission unit, a magnetic recording machine containing the power unit and auxiliary equipment, a complete set of spare glassware and fuses, and interconnecting cables for operation from single phase, 50 or 60 cycles, 115-volt power source.

Exceptional Low Noise Level

A new line of amplifiers and transmission equipment has been developed having exceptionally low noise to take full advantage of the inherent signal-to-noise ratio of magnetic film. The complete recording transmission circuit consists of three amplifiers, two microphone pre-amplifiers, and one main recording amplifier. They are small in size, each with a normal flat gain of 70 db from 30 to 10,000 cycles. Their frequency characteristic may be changed by means of inter-stage plug-in equalizer units.

Only one type of spare amplifier is required, thus reducing maintenance. If it is desired to change the transmission frequency characteristic, it is done merely by changing plug-in equalizer units.

How Many?

Was this copy dog-eared when it came to you? How many men read it ahead of you?

You would receive a clean, fresh copy *if* you had a personal subscription—and you wouldn't have to wait—you would be first to read it.

Use coupon below.

INTERNATIONAL PROJECTIONIST.

19 West 44 St., New York 18, N. Y.

Enter my subscription for 1 year—12 issues—\$2.50
 2 years—24 issues—\$4.00

Foreign and Canada: Add 50c per year.

Name

Address

City State

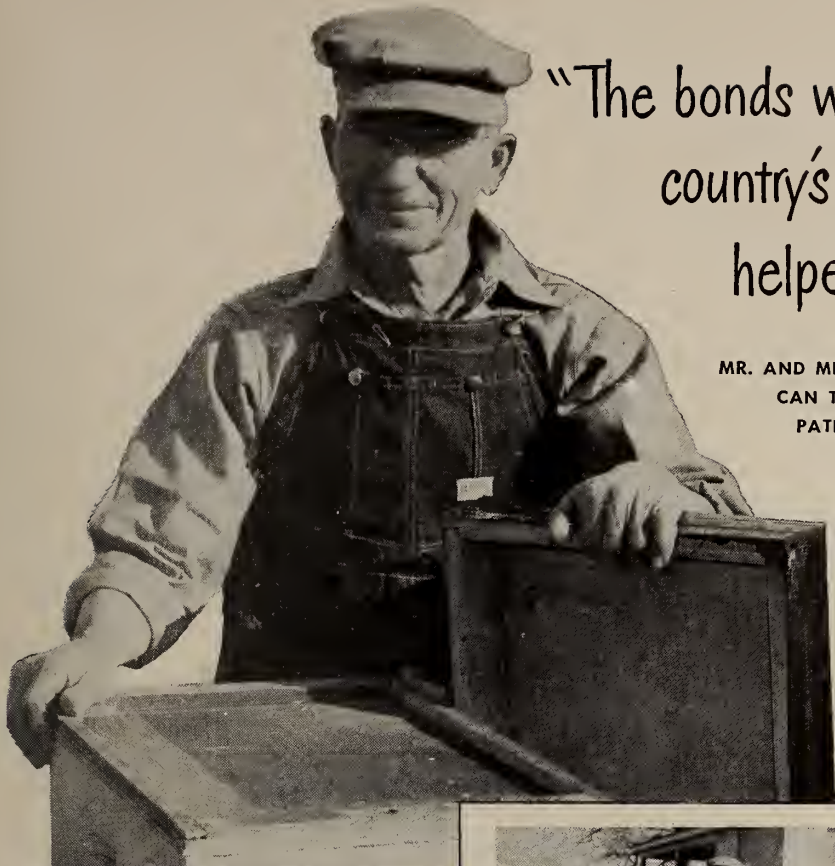

"The bonds we bought for our country's defense bought and helped equip our farm!"

MR. AND MRS. CHARLEY L. WHATLEY OF CUTHBERT, GA. CAN TELL YOU—IT'S PRACTICAL AS WELL AS PATRIOTIC TO BUY BONDS FOR DEFENSE

Mr. Whatley inspects a beehive on his 202-acre farm. "I wouldn't own a farm, clear, today," he says, "if it weren't for U. S. Savings Bonds. We bought a new truck, refrigerator and electric range, too. I've discovered that bonds are the best way of saving for a working man."



Mr. Whatley says, "My wife and I bought our first bonds in 1943, through the Payroll Savings Plan at the Martha Mills plant of the B. F. Goodrich Co. in Thomaston. Our pay averaged \$40 a week apiece and we put about a quarter of that amount into U. S. Savings Bonds."



"We'd saved \$6,925 by 1950. \$4,000 bought us our 202-acre farm and a 6-room house. Then we bought a new truck, a refrigerator and electric range. Now Mrs. Whatley has time for tending her flowers while I can enjoy my hobby of bee-keeping. We owe it all to *planned saving.*"

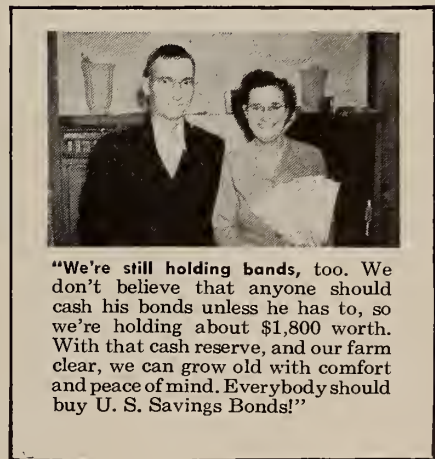

"We're still holding bonds, too. We don't believe that anyone should cash his bonds unless he has to, so we're holding about \$1,800 worth. With that cash reserve, and our farm clear, we can grow old with comfort and peace of mind. Everybody should buy U. S. Savings Bonds!"

The Whatleys' story can be your story, too!

You can make your dream come true, too—just as the Whatleys did. It's easy! Just start *now* with these three simple steps:

1. Make one big decision—to put saving *first*, before you even draw your pay.
2. Decide to save a regular amount *systematically*, week after week or month after month. Even small sums saved on a systematic basis, become a large sum in an amazingly short time!
3. Start saving automatically by signing

up *today* in the Payroll Savings Plan where you work or the Bond-A-Month Plan where you bank. You may save as little as \$1.25 a week or as much as \$375 a month. If you can set aside just \$7.50 weekly, in 10 years you'll have bonds and interest worth \$4,329.02 cash!

You'll be providing security not only for yourself and your family but for the free way of life that's so important to us all. And in far less time than you think, you'll have turned your dreams into reality, just as the Whatleys did.



**U. S. SAVINGS BONDS ARE DEFENSE BONDS
—BUY THEM REGULARLY!**

Your government does not pay for this advertisement. It is donated by this publication in cooperation with the Advertising Council and the Magazine Publishers of America as a public service.



Simplex

**CHOSEN
AGAIN!**

RKO has upheld its fine reputation by maintaining a consistently high standard in motion picture entertainment. The RKO management is proud of this reputation and do all in their power to uphold it. For this reason, they have chosen to install SIMPLEX X-L, the finest in motion picture projectors.

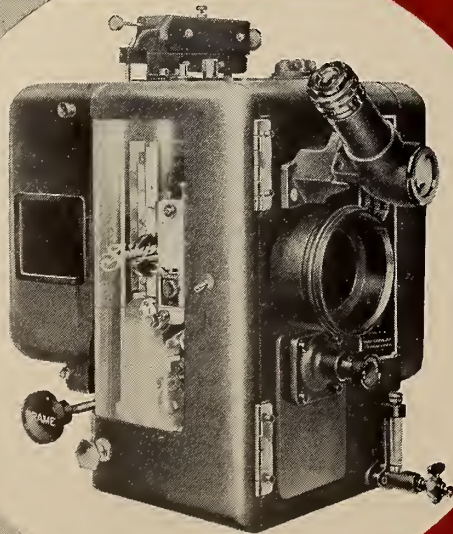

Simplex

**X·L
PROJECTOR**

TO RENT SEE A SHOW

MANUFACTURED BY INTERNATIONAL PROJECTOR CORPORATION • DISTRIBUTED BY NATIONAL THEATRE SUPPLY

B 33 1767

PROJECTIONIST

INTERNATIONAL

JUL 27 1951



THE LIBRARY OF
CONGRESS
JUL 27 1951

JULY

1951

VOLUME 26



NUMBER 7

30c A COPY



\$2.50 A YEAR

ALONGSIDE THESE LAMPS STAND THE WORLD'S FINEST PROJECTIONISTS

Peerless

1-KW TO 70 AMPS

MAGNARC
TRADE MARK REG

"HY-AX" ARC MAGNET

"HY-LUMEN" REFLECTOR

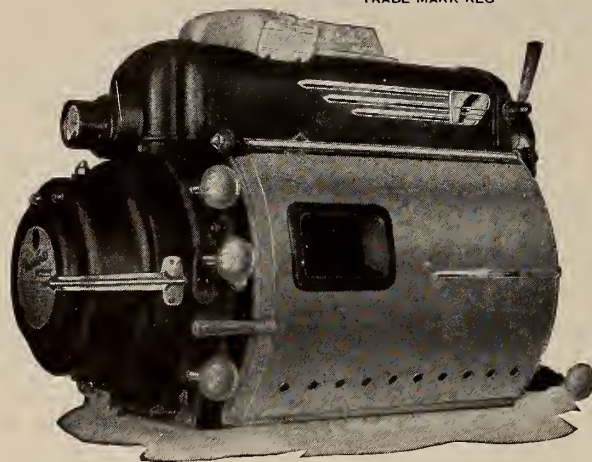

More light at 40 to 70 amperes than ever thought possible. . . . Equals and excels any reflector lamp to 85 amperes, whether they be unapproved water-cooled or resurrected "Hi-Lows". . . . Highest ratio of honest screen lumens per arc watt. . . . At 70 amperes, using an accurated Glass Hy-Lumen Reflector*, with a projector having an efficient revolving shutter, it develops the maximum screen brilliance that can be used without a heat filter at no risk of film damage. . . . Operating costs under these conditions are far below that of 85-ampere lamps.

Magnarc Lamps assure 80% side-to-center (SMPE Standard) screen light distribution, not a deceptive 60% or "Hot Center". . . . They are all Und. Lab., Inc. listed. . . . They are *not* insurance hazards. . . . They are and have been for years "The First Choice" of large and small theatres, drive-ins, and the motion picture industry.

* Similar results are *not* guaranteed if all-metal reflectors are used.

"FIRST WITH THE FINEST"

130-180 AMPERES

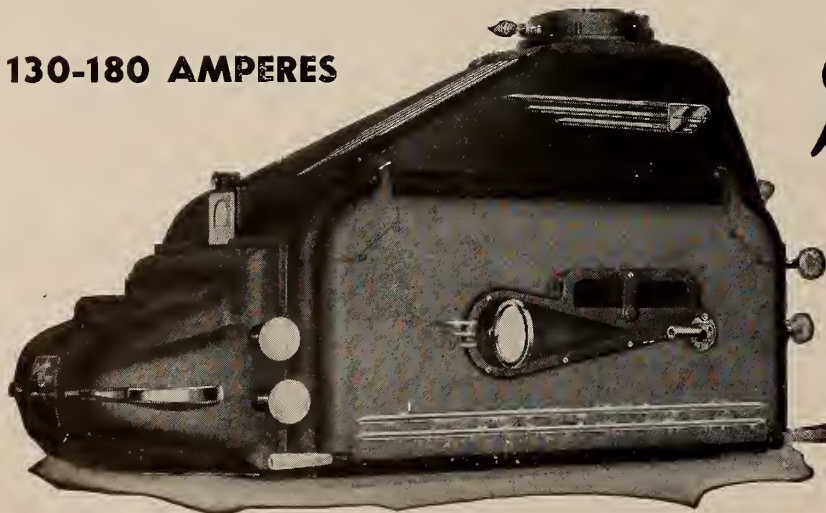

Peerless
HY-AX
CANDESCENT
TRADE MARK REG

NEW MAGNETIC STABILIZER

This modern lamp produces all the light there is. . . . It is the standard equipment of the nation's largest and finest theatres. . . . Used by 90% of the largest Drive-In Theatres.

It is the "Omega" for maximum screen brilliance. . . . Nothing can even approach it in *white* light volume when used with projectors that have efficient revolving shutters.

Assures satisfying projection for Drive-Ins regardless of the size of the picture, length of throw, and under all weather conditions. . . . They are Und. Lab., Inc. listed and, therefore, *not* insurance hazards. . . . Heat filter assures no risk of film-heat damage at maximum arc amperage and maximum screen lumens.

"WHY EXPERIMENT?"



J. E. McAULEY MFG. CO.

552-554 WEST ADAMS STREET
CHICAGO 6, ILLINOIS

INTERNATIONAL PROJECTIONIST

With Which Is Combined PROJECTION ENGINEERING



HENRY B. SELLWOOD, *Editor*

Volume 26 JULY 1951 Number 7

Index and Monthly Chat	3	Proposed Lantern-Slide, Slide-film Standard	16
The Magic of Color, III	5	Tips on Non-Theatrical Movie Slidefilm Showings	16
ROBERT A. MITCHELL		Projection Around the World . .	17
Electronic Color Measuring Instrument	6	In the Spotlight	18
Number of Tv Receivers in Use: Nation-Wide Figures	9	HARRY SHERMAN	
Carbon Arc Screen Light	10	Wide Technical Gains in 1950 .	20
M. T. JONES		SMPTE PROGRESS REPORT	
F. T. BOWDITCH		Telecasts	23
Seven-Year Survey of Film Print Damage	12	GPL's 'Simplex' Direct-Projection Theater Tv System	24
ERNEST TIEMAN		Filters in Tv Projection	24
DENCIL RUSH		News Notes	
Theater Equipment in Critical Supply Listed by NPA	12	Technical Hints	
Effective Cleaning Aids	14	Miscellaneous Items	

Published Monthly by

INTERNATIONAL PROJECTIONIST PUBLISHING CO., INC.

19 West 44 Street, New York 18, N. Y.

Telephone: MUrray Hill 2-2948

R. A. ENTRACHT, Publisher

SUBSCRIPTION REPRESENTATIVES

AUSTRALIA: McGills, 183 Elizabeth St., Melbourne

NEW ZEALAND: Te Aro Book Depot, Ltd., 64 Courtenay Place, Wellington

ENGLAND and DOMINIONS: Wm. Dawson & Sons, Ltd., Macklin St., London, W. C. 2

YEARLY SUBSCRIPTION: United States and possessions, \$2.50 (two years, \$4); Canada and foreign countries, \$3; single copies, 30 cents. Changes of address should be submitted two weeks in advance of publication date to insure receipt of current issue. Entered as second class matter February 8, 1932, at the Post Office at New York, N. Y., under the act of March 3, 1879. Entire contents copyrighted 1951 by International Projectionist Publishing Co., Inc. INTERNATIONAL PROJECTIONIST is not responsible for personal opinions appearing in signed articles in its columns.



MONTHLY CHAT

PREDICTIONS of six months ago anent the impending shortage of materials vitally important to the motion picture theater are, alas, well on the way toward realization. There is no question now that it will take a lot of tall doing on the part of all concerned, particularly by projectionists, to see the job through.

High on the list of materials in critical supply is motion picture film. The physical condition of film, and its conservation, is by no means wholly within the province of the projectionist, but he still is in a position to render a vital service to the over-all program. Probably the most important single factor in preserving film, sprockets, still are in plentiful supply. Why not do a complete sprocket job now?

Slated for revival from World War II days is the plan for salvaging copper drippings from carbons. Mention of this program will force a grim smile from projectionists, who will recall the inept manner in which this task was handled previously, largely because there was no provision for insuring the transit of drippings from projection room to their intended destination. This time, we are assured, things will be different.

Drippings will be picked up regularly from theaters by the film delivery drivers, with ultimate delivery to the reclamation point being assured. We urge all projectionists to give this plan another whirl. If the plan bogs down, IP will sound off, and loudly, in the proper quarter.

Another important angle: many theaters have lying about old equipment, or equipment which by reason of a change of policy will never be used. This is prime fodder for the reclamation program. Much better that it be sold for junk.

It should be distinctly understood that the reclamation program is just now getting up a full head of steam, largely in an anticipatory sense. New equipments of every description, however, are available right now in fulsome measure. If at all possible, buy *NOW*; six months from now may be too late.

PORTENDING a tough battle ahead is the move by Tv set manufacturers in outbidding film theaters for the Ezzard Charles-Joe Walcott fight—\$100,000 as against the \$65,000 bid by the movie houses. Of course, as the theater Tv circuit grows, even \$100,000 will be in the picayune category. Significant here, however, is that the Tv people are not going to see their market for sets harmed by the failure of stay-homers to see those events. This out-and-out subsidy by Tv set makers gives film theaters much to ponder.

GET THE MOST LIGHT

FOR THE LEAST MONEY

with the popular priced

MOTIOGRAPH

**DIRECT CURRENT, HIGH INTENSITY
PROJECTION ARC LAMPS**

Model 19750

FOR SCREENS UP TO 18 FEET WIDE

Projects 7000 lumens burning at
40 to 41 amperes.

Approximate operating cost per hour
for current and carbons
is only 15c.

Model 19746

FOR SCREENS UP TO 22 FEET WIDE

Projects 9400 lumens burning at
45 to 46 amperes.

Approximate operating cost per hour
for current and carbons
is only 19c.



FOR LITERATURE WRITE



Inc.

4431 WEST LAKE STREET • CHICAGO 24, ILLINOIS

EXPORT DIVISION (Except Canada) FRAZAR & HANSEN, LTD., 301 Clay St., San Francisco 11, California

- PROJECTORS
- SOUND SYSTEMS
- PROJECTION LAMPS
- IN-CAR SPEAKERS
- MOTOR-GENERATORS
- RECTIFIERS



The Magic of Color

By ROBERT A. MITCHELL

III. Motion Picture Color Processes

EVEN though certain types of story are more effective dramatically when filmed in monochrome (black-and-white), the increasingly widespread use of color in motion pictures indicates that all but a few feature films will be photographed in full natural color in the near future.

There are several distinct processes by which movies may be made in color on 35-mm film. Of all these various methods, Technicolor is generally regarded as the most satisfactory in regard to color rendition and the preparation of release prints in color.

In order to appreciate the niceties of modern Technicolor, we must turn back the years and glance briefly at a few of the trials and tribulations of Technicolor during its development. The earliest Technicolor films, needless to say, bear scant resemblance to those of the present time. Perfect Technicolor did not come into being in a moment. Like most other modern marvels, many years were required to bring it to its present estate.

Inception of Technicolor

Dr. Herbert T. Kalmus, inventor of Technicolor, first tackled the problem of color movies back in the days of World War I. Then there were no natural-color films which could be run on standard theater projectors at the normal "silent" speed of 16 frames per second.

Color was sometimes *suggested* by ingenious tinting and toning of black-and-white prints; occasionally a novelty reel

such as *Pathe Review* might contain a few feet of hand-colored film. (Hand-coloring required each individual frame of every print to be tinted by hand with water colors.) But no true *natural* color, except Kinemacolor, existed.

Kinemacolor, a British process, was the only noteworthy motion-picture color method in existence at the time Dr. Kalmus made his first experiments along this line (1909). It was the first serious attempt at color movies, even though Kinemacolor prints could not be run on a standard projector operating at normal speed and not fitted out with a rotating color filter. This process, of the greatest historical interest, must therefore be considered non-standard.

The Kinemacolor Process

The Kinemacolor camera made successive exposures through a rotating color filter having two sectors, one red and the other green. The print made from the negative was black-and-white, but *latent* color values resided in the density of the picture images. For example, a red apple in a frame exposed through the red camera filter appeared nearly white, but very dark gray in the succeeding frame exposed through the green camera filter. All that was needed to provide natural color in projection was a rotating filter attached to the projector.

Kinemacolor negative was photographed at 32 frames per second—twice the standard "silent" speed. Because most theater projectors were cranked by hand, it was extremely difficult to double

the film speed in order to project Kinemacolor satisfactorily.

The upshot of this was a motor-driven Kinemacolor projector replete with the rotating filter having red and green sectors. In threading up this machine it was necessary to make sure that even-numbered frames synchronized with the red filter, and odd-numbered frames with the green filter. A mistake of one frame in threading (or in splicing a Kinemacolor print) resulted in a complete reversal of red and green colors in the picture.

Kinemacolor an Additive Process

Kinemacolor was thus an *additive* color method—the two fundamental colors used (red and green) were added together in various proportions to give a semblance of natural color. The eye of the movie patron accomplished the actual *mixing* of the two colors; and this was made possible by the great rapidity with which red and green frames followed one another—32 a second.

A white object in the projected Kinemacolor picture was actually red for 1/32 of a second, green for the same length of time, then red again, green, red, *etc.* An apple would appear red by being almost black when the green frames were projected and red during projection of the red frames.

It was absolutely essential that the frames of the print be projected by the same colors used in exposing the corresponding frames of the negative.

The very first Technicolor film was very much like Kinemacolor, except that the then standard film speed of 16 frames per second was used. But instead of a rotating color filter attached to the projector, every other frame of the print was dyed red all over its area, the alternate frames being tinted green. It may be said that the prints had their own color filters "built in."

The first production filmed in the origi-

nal Technicolor was *The Gulf Between*, released in 1917. This was the first natural-color film which could be run on any 35-mm projector at normal speed and without special attachments. The color reproduction, however, was far from satisfactory. The picture flickered very badly, and bright red and green fringes and halos surrounded all objects in motion.

It is easy to understand why moving objects were fringed with red and green. Adjoining red and green frames were exposed *successively* in the camera, one after the other—not *simultaneously*. A horse's tail, for example, might swish through a considerable distance in 1/16th second. The effect on the screen: two tails, one red and the other green. But when movement ceases, the red and green tails merge into one of natural color, restoring the animal to equine propriety.

Subtractive Process Utilized

Dr. Kalmus then abandoned his original color process for another in which two prints, one of them *toned* red and the other green, were cemented together back to back—a kind of forerunner of the present-day "duplitized" print. This second Technicolor process was important for two reasons. First, a split-beam camera was developed in order to avoid

the color fringes which bordered moving objects. This new camera photographed two frames simultaneously, the intermittent unit pulling down two frames at each shift instead of one. A special optical prism accomplished the beam-splitting. A red filter was placed over one aperture, and a green filter over the other.

Second—and this is very significant.—*subtractive*, rather than additive, color-formation was utilized in projecting the prints. In short, pictures in full natural color were produced *on the positive film*. In the additive process, white is produced on the screen by a rapid succession of colors. But in the subtractive process, white is white on the finished print. This brings up the difference between *tinting* and *toning* positive prints.

It was seen that in the additive process alternate frames were tinted, or dyed, all over their entire area with the appropriate color—red or green. But in the double-print subtractive process the black silver image of each print is bleached out chemically and then *toned* to the desired color. The white areas of the print remain free from color.

Subtractive Process Details

One of the two prints was made from the frames exposed through the green camera filter, the "red" frames being

omitted by step printing. The other print contains only the frames omitted from the first print—that is, the frames exposed through the red camera filter. Each of these two prints is accordingly exactly one-half the length of the complete camera negative from which they were made.

Now, the black-and-white print made from the "green" frames of the negative is toned to a red image, and the print made from the "red" frames to a green image. When combined by cementing them together, the composite print simulates, but does not reproduce exactly, the original colored scene.

Reds, greens, and brown shades came out with great accuracy; but the process was incapable of reproducing pure yellow, violet-blue, and the various purples. This deficiency was caused by the fact that only two colors—orange-red (crimson) and blue-green (aquamarine)—were employed. Because human color vision is *trichromatic*, three colors are needed to give perfect wide-range color reproduction.

Why was each print toned to a color *complementary* to that of the camera filter through which the frames on the negative were exposed?

Suppose a girl in a blue-green dress is photographed. Blue-green looks light-colored through a blue-green filter, but black through an orange-red filter. The positive printed from the green-exposed frames (toned red) reproduces the dress as white, or colorless. The positive printed from the red-exposed frames (toned green) reproduces the dress as green. And when the two toned frames are superposed, there is no red in the image of the dress to subtract green from the light shining through the film. The dress therefore appears green in the picture.

It is therefore a rule for all subtractive color-film printing that the color used for each "separation" be complementary to the color of the filter through which the particular negative was exposed.

This second Technicolor process was far more satisfactory than the additive one with alternate red and green frames. Nevertheless, it contained headaches aplenty. The double prints frequently buckled very badly in the projector—so badly, in fact, that the Technicolor Corporation had to keep "de-cupping" teams on the road to assist projectionists in the running of such productions as *Toll of the Sea*, made in 1922.

Technicolor's Imbibition Printing

But this process was also discarded. Dr. Kalmus, by discovering the secret of *imbibition printing*, had at last cleared the path for really satisfactory Technicolor. This dates back to 1923-1924. Im-

(Continued on page 9)

Electronic Color Measuring Instrument

COLOR from a direct light source can be measured quickly and accurately through the use of a new instrument developed by RCA Laboratories. Called a "tristimulus photometer," the new instrument uses only five electron tubes and is no larger than a shoe-box. It simultaneously determines the relative strength of the three basic color components in a light source under study and gives an instantaneous reading.

Previous methods of color specification require roughly one-half hour of measurement with a spectrometer followed by several hours of computation.

Though the spectrophotometric method gives a higher degree of accuracy, the tristimulus photometer can give values of the three-color components sufficiently precise for every-day engineering work and can readily distinguish between two different color samples which are close enough together in value so they would appear identical to the eye.

Measures Reflected Light Also

The instrument was designed specifically to provide a laboratory and studio check on the faithfulness of color reproduction in color television. However, since it can determine the values of a

reflected light source as well as a direct one, the device may also have valuable application in other industries where color matching is critical.

A direct-reading electronic instrument has been designed by the National Bureau of Standards of the U. S. Department of Commerce, which can define the components of reflected light, but cannot handle a direct light source such as that of a television screen.

Apparatus Has "Eye" and "Brain"

The new instrument consists essentially of an "eye" and a "brain." The "eye" is made up of a lens which focuses the light under study onto a mirror assembly designed to split the beam into three parts of equal intensity. The three beams then pass through three filters, each sensitive to a range of wavelengths corresponding to the basic color components.

The "brain" of the instrument starts with three photocells, one for each filter. The photocells convert the light energy to electrical energy which passes through circuits, each of a different design, to compensate for the mathematical dissimilarities between the three color components. Finally, a corrected value for each component is read on microammeters.



Invitation to Imagination...

Consider the world we live in... Consider the way we live... Consider today's new ideas in motion-picture equipment and materials...

What a tremendous invitation to imagination all this is! No wonder pictures of increasing insight and originality—pictures richer than ever in the use of advanced technics—are now available.

Integral with this progress is the Eastman Kodak Company. Through the Eastman Technical Service for Motion Picture Film, it aids studios and laboratories in the selection and exposure of film, black-and-white and color; helps set up control systems, establish standards of quality and economy, "trouble-shoot" when the need arises; co-operates with exchanges and exhibitors, making sure that each foot of film produces optimum results, gives best possible showing.

To maintain this service, the Eastman Kodak Company has branches at strategic centers... invites inquiry on all phases of film use from all members of the industry. Address:

Motion Picture Film Department

EASTMAN KODAK COMPANY

Rochester 4, N. Y.

East Coast Division
342 Madison Avenue
New York 17, New York

Midwest Division
137 North Wabosh Avenue
Chicago 2, Illinois

West Coast Division
6706 Santa Monica Blvd.
Hollywood 38, California

EVERY BIG SCREEN IS A STRONG-SIZED LIGHTING JOB



THAT'S WHY DEALERS ARE GOING STRONG

More dealers sell Strong-made lamps than sell any other make. As the only lamps produced complete within one factory, Strong projection lamps can be so engineered as to obtain the finest screen results, the highest efficiencies ever obtained. Long, dependable service is assured. Some Strong lamps, built as long as 28 years ago, are still working every day.

That's why, year after year, more theatres prefer Strong lamps—why continual expansion of plant facilities has been necessary.



ALWAYS THE BIGGEST VALUES IN LAMPS ALWAYS THE LATEST DEVELOPMENTS

As the world's largest manufacturer of projection arc lamps, Strong has a line that includes lamps especially designed for best results under every condition. Send coupon today for free literature.

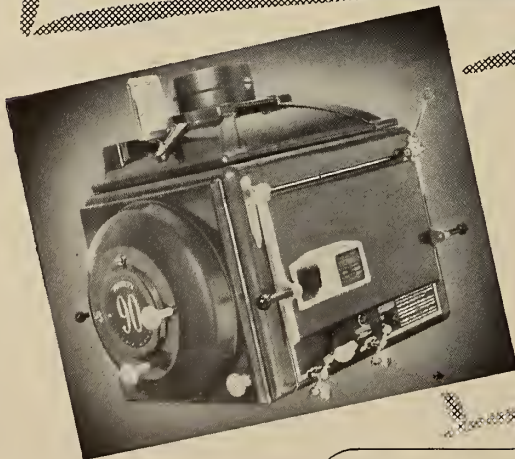

The Strong Mighty "90", 75 to 130 ampere reflector arc lamp, not only delivers positively the most light that can be projected to any screen, REGARDLESS OF HOW LARGE, but at 90 amperes projects 21,000 lumens AT FAR LESS COST than other types of big lamps!

- Exclusive Lightronic automatic focus control.
- Big 16½" reflector, the largest used in any lamp, matches high speed f/1.9 lens.
- Forced air cooled feed mechanism. Low operating temperatures. Rugged burner mechanism.
- Bi-Metal Lightronic tube controls both carbon feed motors. Simple feed rate adjustment.
- Air stream arc stabilization. Complete combustion of black soot. White deposit on reflector prevented.
- Unit construction permits instant removal of major components.

*When the lamps are **STRONG** the picture is bright!*

THE STRONG ELECTRIC CORPORATION

31 CITY PARK AVENUE

TOLEDO 2, OHIO

I would like a demonstration of the Strong Mighty "90" in my theatre without cost or obligation.

Please send free literature on the Mighty "90"; Mogul Lamp; Utility Lamp; Strong Arc Spotlamps; Strong Incandescent Spotlights; Strong Rectifiers; Strong Reflectors.

NAME _____

THEATRE _____

STREET _____

CITY & STATE _____

bibition printing still is the heart and soul of the Technicolor process.

A fundamental requirement to be met in subtractive color printing is *exact registration* of the superimposed colored picture-images. If the superimposed images are not accurately registered, the colored picture will look blurry on the screen, no matter how carefully the projectionist focuses the lens.

With the old-style Technicolor, only two colors, crimson and aquamarine, had to be combined. This was hard enough to do; but modern Technicolor makes use of three printing colors. The perfection of modern full-range Technicolor is a truly marvelous engineering achievement.

But let us return to old-style Technicolor to see how the first imbibition-printed color films (*The Black Pirate* in 1925, followed by *The Viking* and a number of "fashion reels") were made.

Early Imbibition Printing

From the negative made in the split-beam movie camera, two positive prints are made, one from the "red" frames and the other from the "green" frames, as previously described. Instead of being toned, however, the two prints are left uncolored. These are not intended for

projection, but are converted by Technicolor magic into "wash-off relief" printing films called *matrices*.

The two positives are chemically treated to convert the black silver images they contain into creamy-white silver chloride. A subsequent "tanning" operation results in a hardening of the gelatine in the image. Washing then removes all of the gelatine from the clear areas of the film. This leaves the image in faint outline, raised in relief like a rubber stamp. The dark and light portions of the picture are therefore represented by varying thicknesses of hardened gelatine.

All that now remains to be done is to print colored positives from the two matrices for projection. This feat requires a special printing machine which bears not the slightest resemblance to a regular black-and-white film printer. The imbibition process is not photographic at all—it is more like lithography than anything else. Clear gelatine-coated film is used as the printing stock. It need not contain any silver unless a soundtrack is to accompany the picture.

The matrix made from the green-exposed frames is passed over rollers which transfer red (crimson) dye to its relief images. The gelatine of these images soaks up the dye, the amount of ink any

particular part of the image imbibes depending on the thickness of the gelatine. Areas having thick gelatine soak up a large amount of dye; thin layers of gelatine imbibe relatively little; the clear film-base none at all. The other matrix—the one made from the red-exposed frames—is treated with green (aquamarine) dye.

As the process was carried out, the clear gelatine-coated film used as raw stock was impressed first with the crimson and then with the corresponding aquamarine images in superposition. Pressure rollers effected the impression. To insure perfect registration, the raw printing stock and the matrices are held very taut in the printing machine. The sprocket teeth are the exact shape and size of the film perforations.

Technicolor Positive Prints

The Technicolor positive is ready for projection as it comes from the printer. A large number of positives may be printed from a single set of matrices; but when these wear out, a new set is made from the camera negatives.

The emulsion side of an imbibition print has a glossy appearance, almost

(Continued on page 33)

Number of Tv Receivers in Use: Nation-Wide Figures

The following figures are based on the population residing within the 0.1-millivolt contour, which is considered to fall approximately 60 miles from station. Computations

based on national totals projected to June 1, 1951. This table prepared, published and copyright, 1951, by TELE-TECH, the leading journal in the electronics field.

City	Families	Sets Installed	% Saturation	Number of Stations	City	Families	Sets Installed	% Saturation	Number of Stations
Ames	195,200	49,000	25%	1	Pittsburgh	729,200	247,000	34%	1
Atlanta	311,000	99,000	32%	2	Providence	406,100	141,000	34%	1
Baltimore	461,000	292,000	63%	3	Richmond	133,700	70,500	53%	1
Birmingham	252,400	47,500	19%	2	Rochester	216,700	795,000	37%	1
Bloomington	49,300	15,400	32%	1	Schenectady	322,500	151,000	47%	1
Boston	1,084,000	720,000	66%	2	St. Louis	567,700	275,000	48%	1
Buffalo	309,400	195,000	63%	1	Syracuse	205,200	111,000	54%	2
Charlotte	330,800	63,000	19%	1	Toledo	300,100	89,000	30%	1
Chicago	1,668,400	910,000	55%	4	Utica	124,100	39,500	32%	1
Cincinnati	432,600	249,000	58%	3	Washington	450,600	249,000	55%	4
Cleveland	804,800	465,000	58%	3	Wilmington	135,400	61,000	45%	1
Columbus	327,300	141,000	43%	3					
Davenport	205,100	51,000	25%	2					
Dayton	275,500	123,000	45%	2					
Detroit	907,200	450,000	50%	3					
Erie	84,800	45,500	54%	1					
Grand Rapids	194,500	79,000	41%	1					
Greenboro	162,100	59,000	36%	1					
Huntington	187,500	39,000	21%	1					
Indianapolis	390,200	120,000	31%	1					
Jacksonville	113,800	28,700	26%	1					
Johnstown	310,100	77,000	35%	1					
Kalamazoo	153,700	36,000	23%	1					
Kansas City	471,900	111,000	24%	1					
Lancaster	215,900	86,500	40%	1					
Lansing	206,900	47,200	23%	1					
Louisville	256,400	85,000	33%	2					
Memphis	269,900	81,000	30%	1					
Milwaukee	373,600	232,000	62%	1					
Minneapolis	452,900	257,000	57%	2					
Nashville	205,700	25,500	12%	1					
New Haven	515,400	149,000	29%	1					
New York	3,887,000	2,300,000	59%	7					
Norfolk	204,200	61,500	30%	1					
Omaha	217,600	68,000	31%	2					
Philadelphia	1,343,900	835,000	62%	3					

NON-INTERCONNECTED CITIES				
City	Families	Sets Installed	% Saturation	Number of Stations
Albuquerque	133,100	8,100	6%	1
Binghamton	84,100	35,300	42%	1
Dallas, Ft. Worth	369,800	111,000	31%	3
Houston	307,500	71,000	23%	1
Los Angeles	1,537,800	890,000	58%	7
Miami	154,600	56,500	37%	1
New Orleans	257,700	53,500	21%	1
Oklahoma City	239,000	81,500	34%	1
Phoenix	89,600	38,500	43%	1
Salt Lake City	83,700	39,500	47%	2
San Antonio	157,000	42,500	27%	2
San Diego	182,100	89,000	49%	1
San Francisco	974,300	171,000	18%	3
Seattle	425,400	77,000	18%	1
Tulsa	152,500	67,000	44%	1
Total Stations	107	Total TV Sets	12,752,700	
Total Families	26,571,500	Average Saturation	48%	

Carbon Arc Screen Light[†]

By M. T. JONES and F. T. BOWDITCH
National Carbon Co. Research Laboratories

In a carbon arc motion picture projector, definite relations exist between screen light on the one hand, and the arc current, current density, carbon size and the speed and collection angle of the projector optical system on the other. Measurements on more than 100 standard and experimental carbon arcs, with carbons ranging in size from 9- to 16-mm, have provided data to establish these relationships.

IN AN earlier paper¹ a method is described for calculating motion picture screen light from measurements of brightness over the carbon arc crater as viewed from selected angles, and from a consideration of the characteristics of the particular optical system involved. This method has now been applied to a variety of standard and experimental carbons, and the resulting data analyzed to establish certain significant relationships.

These relationships are concerned with the distribution and the amount of light delivered to the motion picture screen, as these are determined by the arc current, the current density, the size of carbon and the collection angle and speed of the optical system.

As an illustration of the basic data from which these trends are established, calculations made from measurements on three experimental trims, each at its maximum operating current, are shown in Figs. 1, 2 and 3. In this, and in all subsequent cases throughout this paper, these calculations are made according to the method previously described,¹ for the one best-focus condition giving maximum screen light.

Light Loss Correction of Data

Each of these curves shows, on the left, the lumens through the motion picture aperture and, on the right, the light distribution across the aperture, each over a range of light-collecting angles from the source, and for a series of optical speeds into the aperture.

Light losses due to absorption, shadowing and vignetting, which always occur in varying degree in any specific optical system, have not been included in these present calculations, a permissible simplification since only relative values are considered in the conclusions drawn here.

A suitable loss correction of approximately 50% would have to be applied to the lumen values given in this paper in order to determine the actual screen-light level in any particular instance.

As an example, crater light measurements on an 8-mm to 7-mm "Suprex" trim at 70 amp, calculated for an F:2.0 mirror, predict a flux of 27,600 lm on the aperture, compared with 14,000 lm motion picture screen light realized in practice. This is because mirror absorption and reflectance losses, plus shadowing due to the positive head, etc., amount to about 20%; while of the total lumens passing the film aperture, no more than about 65% reaches the screen due to a combination of spill-over, vignetting and glass transmittance losses at the projection lens.

With respect to the aperture-lumen variations shown by Figs. 1, 2 and 3, these confirm the earlier conclusion¹ that maximum luminous flux is not necessarily obtained at the maximum collection

angle; the simple concept that a bigger collection angle picks up more light from the source and hence delivers more light to the picture screen fails to work out.

With a fixed speed into the aperture, the optical geometry is such that the magnification of the crater image on the aperture increases as the pickup angle increases, thus introducing a loss factor, working against the greater light collection.

The light distribution characteristics of high-intensity carbon arcs are such that a collection angle is reached at each speed beyond which more light is thrown outside the aperture by the enlarged image than can be collected by the higher pickup angle. The exact pickup angle at which this maximum light value occurs will depend in each instance on the particular light distribution characteristics of the carbon in question.

Various Trims Light Characteristics

A small carbon, for instance, with a peaked light distribution, effectively utilizes a higher magnification ratio and hence a higher pickup angle than is required with a larger carbon with a more uniform light distribution.

Figure 1 gives the light characteristics of an experimental 9-mm carbon oper-

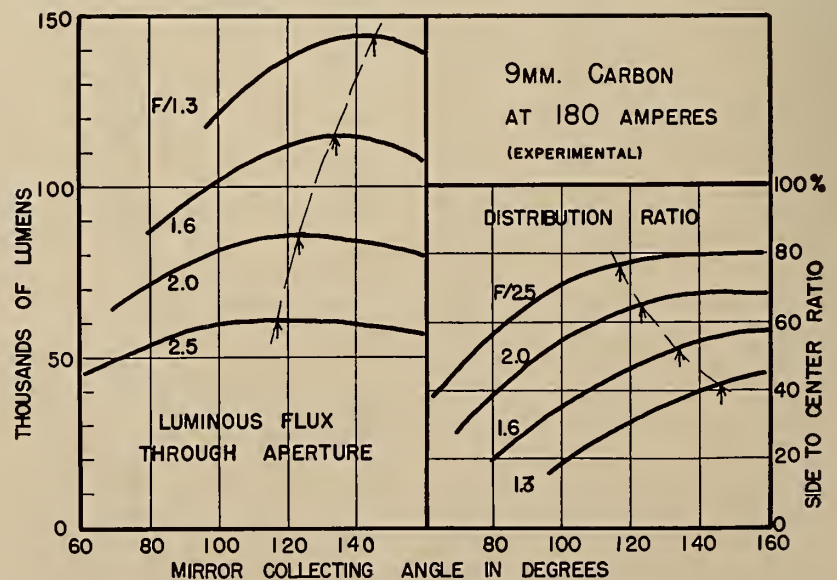

FIG. 1. Screen-light characteristics of an experimental 9-mm high-intensity positive carbon at its maximum operating current in water-cooled jaws.

NOTE: All light and distribution values throughout this paper are based upon the best-focus condition giving maximum screen light.

[†]J. Soc. Mot. Pict. & Tv Eng., March, 1951.
¹"Motion Picture Screen Light as a Function of Carbon Arc Crater Brightness Distribution," by M. T. Jones; J. Soc. Mot. Pict. Eng., Sept., 1947.

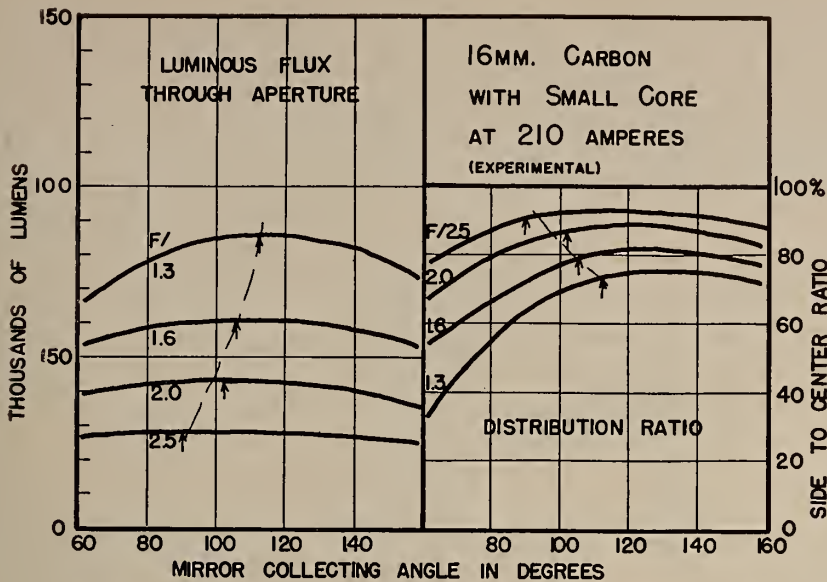

FIG. 2. Screen-light characteristics of an experimental 16-mm high-intensity positive carbon, with small core, at its maximum operating current in water-cooled jaws.

ated at 180 amp, a very high current for this size. It is seen that high collection angles are effectively utilized at the various optical speeds to give good screen light values, but at comparatively low distribution ratios.

Figure 2 shows the similar characteristics for an experimental 16-mm carbon with a small core, operated at 210 amp. Here a much smaller collection angle gives maximum screen light, and the distribution ratios are considerably higher.

Figure 3 shows the light-output characteristics of another experimental 16-mm carbon with a large core, operated at 460 amp, the maximum current used with any of the approximately 100 positive carbons upon which the conclusions of this paper are based. Particularly with this carbon, the light output and distribution ratio are comparatively insensitive to the choice of collecting angle, since, with the large core and high current, the effective source is quite large and of more uniform brightness.

Light Distribution Ratio

It might be noted that in no case is a 100% distribution ratio reached. Particularly with the large-cored 16-mm carbon at F:2.0, the effective source size is quite sufficient to fill the aperture completely from all angles of view. However, the crater of any high-intensity carbon is always brightest near the center, and this peak is carried through as higher illumination in the center of the screen.

Data such as those shown in the preceding figures have been correlated for approximately 100 different positive carbons, both production and experimental types, of 9-, 11-, 13.6- and 16-mm diameter. It is, of course, recognized that the smaller 7- and 8-mm Suprex carbons are

very important items, commercially, although they were not within the scope of the investigation reported here.

Certain basic behaviors have been disclosed by these correlations. The first such relationship is that between screen lumens and arc current for various carbon sizes and optical speeds.

Basic Behaviors Revealed

Figure 4 shows this relationship at a speed of F:2.0 and for carbons of 9-, 11-, 13.6- and 16-mm diameter. Each curve results from measurements on a number of different-type carbons of a given size, each carbon represented by a single value determined at the maximum stable current for that carbon.

For example, referring to the extreme points on the curve for the 16-mm size,

one type of 16-mm positive carbon was found to give 32,000 lm at its maximum current of 150 amp; while another 16-mm positive carbon of very different construction gives 68,000 lm at its maximum current of 460 amp.

The curves of Fig. 4 show the smallest carbon most efficient in current utilization, although, as will be indicated later, factors other than maximum current efficiency are involved in the choice of a preferred trim for a particular situation.

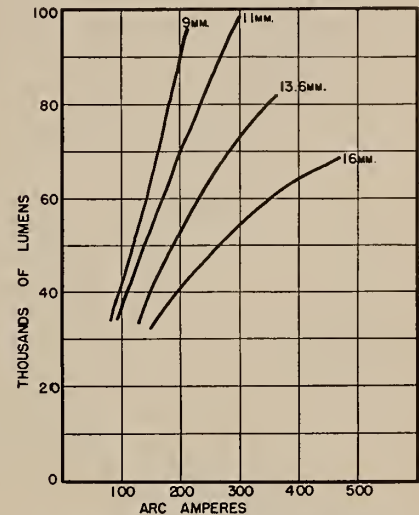

FIG. 4. Relation between screen light and arc current at an optical speed of F:2.0.

It will be noted that the curves for the 13.6- and 16-mm carbon sizes are concave downward, indicating a falling-off in current efficiency with increasing amperage on a given size, which is probably the result of the inability to cool the larger diameters as effectively as the smaller. For instance, the 16-mm carbon at 150 amp gives more than 200 lm/amp;

(Continued on page 30)

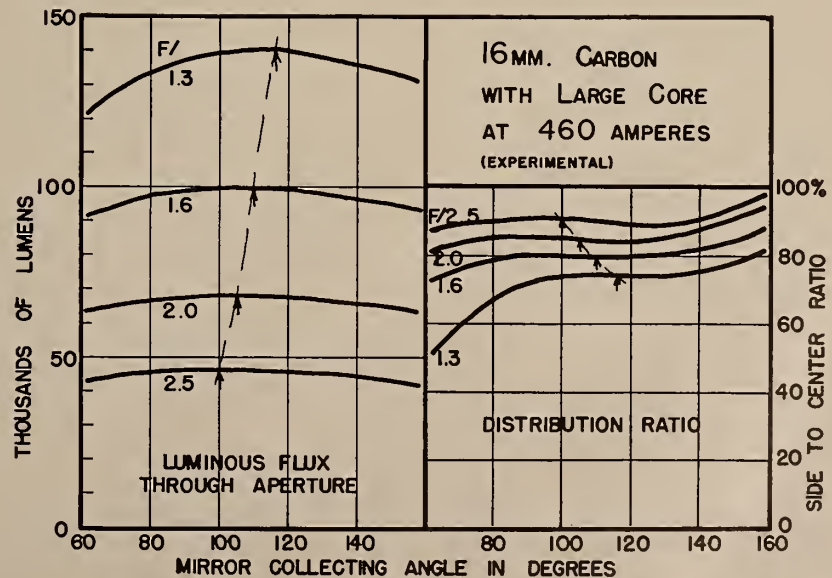

FIG. 3. Screen-light characteristics of an experimental 16-mm high-intensity positive carbon, with large core, at its maximum operating current in water-cooled jaws.

Seven-Year Survey of Film Print Damage

By ERNEST TIEMANN and DENCIL RICH

University of Indiana Film Center

IN VIEW of the emerging critical shortage of raw film stock, the division of adult education and public services at Indiana University has made a number of studies covering a seven-year period to determine the cost of film maintenance and film damage and ways to reduce such film damage.

In making the study, a detailed classification of injuries to film was developed from film damage reports filled out by inspectors of periodical analysis and evaluation. From this information a complete report was prepared to determine what course of action needs to be taken to assist users in keeping film damage to a minimum.

Accessioned print control, inspection, and booking cards were studied for each of the 192 prints. It was found that careful inspection and use records were maintained for each of these films. By checking the booking records, we found that the 192 prints were used a total of 18,149 days—an average of 94.5 days for each film.

Average Replacement Footage

We discovered that for the seven-year period 83 of the 192 prints were damaged to the extent that replacement footage was needed. A total of 110 different replacement parts were added, requiring 5,264 feet of film. All of these replacements were black-and-white except one. The total cost amounted to \$476.36. Our figures showed that the average cost for replacement footage per print has been approximately \$2.50. Our maintenance costs for replacement parts alone totaled \$2.50 for each print in general during the seven years.

Our further study showed that a number of factors influence the maintenance cost of damaged film replacement. These include: 1) the number of bookings; 2) standards of maintenance; 3) proportion of black-and-white and color prints; 4) fluctuating costs of replacement parts; 5) technical improvement in projection equipment; 6) training of projectionists.

Faulty Threading a Major Cause

We find that the damage of sprocket teeth marks on sound tracks is no longer as serious as it was in former years. This may be due to one of two things, or both: the use of silent projectors has dropped off considerably, or the literature sent out by many film distributors is working for our benefit also. Many of these concerns are using leaflets with their shipments which warn of the consequences of

threading sound film into silent projectors.

Were it not for our constant practice of keeping each film provided with a leader and credit title of appropriate length, the damages reported would no doubt be much more numerous. On many occasions various films are saved from injury by the fact that the leader and the credit title serves as the necessary margin of warning to the operator to stop the machine when the film does not feed correctly.

Failure of proper loop formation, for instance, accounted for many of the numerous injuries at the beginning of films. We are overcoming this hazard to a considerable extent by sending all users of our films, without cost, a 100-foot roll of practice film. We recommend this procedure to all film libraries as a sound measure of reducing film damage.

Checking Procedure Followed

Our survey has borne out our previous conclusion that 800-foot films require proportionately less maintenance expense than films of shorter length. In our library, 800-ft. prints comprised approximately 26% of the total, yet only 17 per cent of the partial damages and 17 per cent of the total damages were among these films. Damages rarely occur at the ends of 800-ft. films.

As a basis for our study, we followed the following procedures:

Theater Equipment in Critical Supply Listed by NPA

NPA has asked IP to enlist the support of all projectionists in the conservation of critical materials needed for national defense.

Full cooperation of the motion picture industry in promoting conservation and salvage of critical materials to aid the nation's defense effort was promised by motion picture industry representatives at a recent conference with NPA officials.

Need for conservation of such materials as copper, cobalt and nickel, used in manufacture of motion picture equipment is acute. A single jet engine requires one ton of nickel. A shortage of in-car speakers for drive-in theaters looms within the next few months, officials say. Demand for loudspeakers for this use can be met by repairing defective speakers which ordinarily are discarded and by guarding against loss of speakers. Speaker magnets contain nickel and cobalt. As these magnets may be used again in rebuilt speaker units, NPA pointed out that manufacturers and distributors who establish a rotating inventory of rebuilt speaker units will help greatly to keep the drive-in theaters in operation.

Other conservation measures discussed

We separated total from partial damages, then broke down the reports into months and into the four lengths of films involved—400, 800, 1200, and 1600 feet. For each month for each length of film we tabulated and classified all the damages, indicating the data relative to the color of the film amount and location of the injury, and the type of injury.

After all damages were classified each damage type was given a code number for ease in handling data. There were 28 such classifications which we set up in a series of charts from which the conclusions herein were taken.

Some Damage Classifications

In the survey, the total black-and-white film damage at the beginning of 400-foot films amounted to 2863 feet, with 814 feet of color film damaged. Chipped sprocket holes accounted for 40% of the 96 damages reported.

Damages that started and ended in the middle of 400-foot films amounted to 1874 feet for black-and-white, and 271 feet for color film. On the extreme end of 400-foot films, a total of 58 damages was found. Damage to black-and-white film amount to 1225 feet, and 589 feet of color film were damaged.

A total of 57 damages on 800-foot black-and-white films were found, and a total of 10 damages on color film was found. Total footage damaged on black-and-white film amounted to 1386 feet, and 686 feet on color film. Few damages to 1200-foot films were found, with only 31 reported and 1081 feet damaged. On 1600-foot films, 22 damages were reported, with 2442 feet of film involved.

centered on copper drippings, dry plate rectifiers, obsolete equipment and film handling. Trade sources estimate that 100,000 pounds of pure copper could be recovered, annually, from motion picture theater drippings. The copper content of the drippings averages about 94%.

Manufacture of copper-oxide dry plate rectifiers up to 65-ampere capacity may have to be prohibited to save copper. This dry plate rectifier uses about 35 pounds of copper, in contrast to the one-half pound of copper used in tube rectifiers. If making of copper-oxide dry plate rectifiers up to 65 ampere capacity is prohibited, NPA does not contemplate eliminating manufacture of repair parts for rectifiers now installed.

Thirty-five mm film is the most critical of all the materials used in the motion picture industry. NPA stressed the need for great vigilance in handling film to get the greatest possible use from the available supply.

A SHARP, SNOW-WHITE SPOT

Quiet · Flickerless · Portable
REQUIRES NO HEAVY ROTATING EQUIPMENT



THE STRONG TROUPER

HIGH INTENSITY ARC SPOTLIGHT

Ideal for theatres, auditoriums, arenas, hotels, ice shows, schools, colleges and lodges. Draws only 10 amperes from any 110-volt A.C. convenience outlet. Adjustable, self-regulating transformer in base. Silvered glass reflector. Two-element variable focal length lens system. Automatic arc control. A trim of carbons burns one hour and 20 minutes at 21 volts and 45 amperes. Easily disassembled for shipping.



6 1/2 TIMES BRIGHTER HEAD SPOTS

Sharp Edges From Head Spot to Flood

THE STRONG TROUPERETTE INCANDESCENT SPOTLIGHT

for night clubs, small theatres and schools where physical dimensions and price are factors. As contrasted to conventional incandescent spotlights, with which the spot size is varied solely by iris, to result in substantial light loss, the Troupetrette utilizes all the light through most of the spot sizes. Variable focal length objective lens system, 5/4"

silvered glass reflector, Fresnel lens. Uses standard 115-volt, 1000-watt prefocused projection type bulb. Horizontal masking control can be angled at 45 degrees in each direction. Fast operating color boomerang accommodates six slides. Height adjustable mounting stand. Plugs into any 110-volt convenience outlet.

SEE ANY OF THE FOLLOWING DEALERS OR USE COUPON FOR OBTAINING LITERATURE

ALBANY, N. Y.—Nat'l Theatre Supply Co.; Albany Theatre Supply
 ATLANTA—Nat'l Theatre Supply Co.
 ATLANTIC CITY—Boardwalk Film Enterprises
 AUBURN, N. Y.—Auburn Theatre Equipment
 BALTIMORE—J. F. Dushman Co.; Nat'l Theatre Supply Co.
 BIRMINGHAM—The Queen Feature Service, Inc.
 BOSTON—J. Cifre, Inc.; Nat'l Theatre Supply Co.
 BUFFALO—Dion Products; Nat'l Theatre Supply Co.
 CHARLOTTE—Nat'l Theatre Supply Co.; Standard Theatre Supply Co.
 CHICAGO—Abbott Theatre Equipment Co.; Droll Theatre Supply Co.; Gardner Jansen, Inc.; Grand Stage Lighting Co.; Hollywood Stage Lighting Co.; Midwest Stage Lighting Co.; Nat'l Theatre Supply Co.
 CINCINNATI—Nat'l Theatre Supply Co.
 CLEVELAND—Nat'l Theatre Supply Co.
 DALLAS—Hardin Theatre Supply Co.; Modern Theatre Equipment Co.; Nat'l Theatre Supply Co.
 DENVER—Nat'l Theatre Supply Co.; Graham Bros.
 DES MOINES—Nat'l Theatre Supply Co.
 DETROIT—Nat'l Theatre Supply Co.
 FORTY FORT, PA.—V. M. Tate Theatre Supplies
 GREENSBORO, N. C.—Standard Theatre Supply Co.
 HOUSTON—Southwestern Theatre Equipment Co.
 INDIANAPOLIS—Nat'l Theatre Supply Co.
 KANSAS CITY, MO.—Shreve Theatre Supply; Nat'l Theatre Supply Co.
 LOS ANGELES—J. M. Boyd; C. J. Holzmüller; Nat'l Theatre Supply Co.; Pembrex Theatre Supply Corp.
 LOUISVILLE—Falls City Theatre Supply Co.
 MEMPHIS—Nat'l Theatre Supply Co.

MILWAUKEE—Nat'l Theatre Supply Co.; R. Smith Co.
 MINNEAPOLIS—Minneapolis Theatre Supply; Nat'l Theatre Supply Co.
 NEW HAVEN—Nat'l Theatre Supply Co.
 NEW ORLEANS—Nat'l Theatre Supply Co.
 NEW YORK CITY—Nat'l Theatre Supply Co.
 NORFOLK—Nat'l Theatre Supply Co.
 OKLAHOMA CITY—Nat'l Theatre Supply Co.; Oklahoma Theatre Supply Co.; The Century Theatre Supply Co.
 PHILADELPHIA—Blumberg Brothers; Nat'l Theatre Supply Co.
 PITTSBURGH—Atlas Theatre Supply; Nat'l Theatre Supply Co.
 SALT LAKE CITY—Inter-Mountain Theatre Supply Co.
 SAN FRANCISCO—C. J. Holzmüller; Nat'l Theatre Supply Co.; W. G. Preddy Theatre Supplies

SEATTLE—B. F. Shearer Co.; Nat'l Theatre Supply Co.
 SIOUX FALLS—American Theatre Supply Co.
 ST. LOUIS—City Electric Co.; Nat'l Theatre Supply Co.
 TOLEDO—Theatre Equipment Co.
 WESTERLY, R. I.—G. H. Payne Motion Picture Service

CANADA—
 Dominion Sound Equip., Ltd., Montreal, Que.
 General Theatre Supply Co., Toronto, Ont.
 General Theatre Supply Co., St. John, N. B.
 General Theatre Supply Co., Vancouver, B. C.
 General Theatre Supply Co., Montreal, Que.
 General Theatre Supply Co., Winnipeg, Man.
 Perkins Electric Co., Ltd., Montreal, Que.
 Perkins Electric Co., Ltd., Toronto, Ont.
 Sharp's Theatre Supplies, Ltd., Calgary, Alta.

THE STRONG ELECTRIC CORPORATION

"The World's Largest Manufacturer of Projection Arc Lamps"

14 CITY PARK AVENUE

TOLEDO 2, OHIO

Please send free literature on the Strong Troupetrette Incandescent Spotlight;

Strong Trouper Arc Spotlight.

NAME _____

COMPANY _____

STREET _____

CITY & STATE _____

Effective Cleaning Aids

BOTH as routine, to keep his apparatus in top trouble-free condition, and on special occasions, as when a generator bearing threatens to "freeze," the projectionist is faced with cleaning jobs. Mechanical aids, such as brushes, rags, lens tissue and vacuum cleaner are obvious helps. Liquid or "chemical" cleaning aids are not always so well understood because they are of several types, and the right type must be used for a given job. They act primarily by dissolving the dirt, and the kind of liquid to be used depends upon the kind of dirt to be dissolved. The type of apparatus on which the cleanser is to be used must also be considered.

Classifying these "chemical" aids in the broadest possible sense, they are of three general types. One, of course, is water—hot or cold. A second consists of non-aqueous solvents—liquids that dissolve substances which water won't attack—for example, carbon tetrachloride. The third and most numerous type might be called coupling agents—something that couples water with substances that normally do not dissolve in water, enabling the water to dissolve them. A more correct but narrower term for "coupling agent" is "emulsifying agent." Common soap is an emulsifying agent but by no means the best one for all purposes.

Non-Aqueous Solvents

What cannot be cleaned with water—as applied, for example, with a damp rag—may perhaps be cleaned by substances of the second type named, carbon tetrachloride, for example, applied by means of a rag. In the case of a motor or generator bearing, where the lubrication has gummed and must be removed and replaced, carbon tetrachloride also is used. So is kerosene, warm or cold; and hot oil—the same lubricating oil—is very useful.

Wherever oil or grease must be removed, water alone can be ruled out as ineffective. Oil and water don't mix. An emulsifying agent is needed to make them mix—soapy water will remove grease that plain water won't touch. But there are also direct solvents, as stated, depending on the type of oil. In addition to those already mentioned, alcohol and acetone may prove effective.

Various Coupling Agents

Alcohol and acetone, although solvents in their own right, can act more or less as coupling agents, that is, some substance not soluble in water can often be washed away by mixtures of alcohol and water, or of acetone and water. Tri-sodium phosphate, or tetra-sodium phos-

phate, which can be obtained either at the drug store or from the firm that supplies the theatre's porters with cleaning materials, are highly effective on some problems. Many commercial soap powders and cleansers, obtainable at any grocery, are mixtures of these phosphates and common soap.

Hydrogen peroxide—which actually consists of about 2% peroxide and 98% water—acts as a coupling agent in cleaning out projector heads after film fires. The action in this case possibly is one of oxidation rather than an emulsifying action. Common lye has a very powerful action on some types of grease in still another way—it converts the grease to soap.

The practical problem confronting the projectionist in his choice of cleaning agents boils down to three simple, practical points: the agent must be effective, it must not cause corrosion.

Effectiveness can always be determined by trial and error; the other two points will require either some understanding of the actions involved or else a small bit of memorizing.

Harmful Cleanser Residues

As to harmful residues: any substance which does not evaporate completely is going to leave a residue which may or may not be harmful. Soap, unless most thoroughly flushed away, will leave a soapy film. Tri-sodium phosphate and similar detergents, unless thoroughly flushed away, will leave crystalline deposits. Hot oil used for cleaning bearings and grease cups is almost certainly going to leave an oily film behind—that is why only the same lubricating oil should be used. Kerosene is for that reason less satisfactory: some will remain to dilute the new lubricant at first. However, it is slowly volatile and in time will evaporate. Carbon tetrachloride will evaporate quickly.

Acetone, alcohol and carbon tet all evaporate much faster than water. They leave no residue. Water leaves none, neither does hydrogen peroxide. However, water and hydrogen peroxide are a little slow to evaporate, and they may cause some corrosion before they disappear completely.

Hydrogen peroxide has a corrosive effect on metals; this applies to water also, but to a somewhat lesser extent. Soapy water not thoroughly flushed off is particularly corrosive because any film that remains behind will be a film of water as well as soap, and the water won't dry off for a very long time. The soap will hold it in contact with the metal, keeping the metal moist, possibly for weeks.

Stirring kerosene into water, up to

about one part kerosene to two parts water, reduces the possibility of the water causing corrosion of metal with which it comes into contact.

Kerosene and hot oil, alcohol, acetone and carbon tetrachloride produce no appreciable corrosion. Lye is extremely corrosive.

Solvent Effect on Film

Acetone and even alcohol have a solvent effect on motion picture film, and should not be used, or used only with great care, in cleaning film or grease. Hot water exercises a solvent action on the emulsion of film, tending to soften or dissolve it. Even cold water may cause the emulsion to swell after a period of time, but can be used for cleaning film with perfect safety unless the film is going to be left wet for hours.

The "organic" solvents—carbon tet, alcohol, acetone—should not be used in cleaning compound lenses. Should they seep into the cement that holds the lenses together, they may dissolve it.

Many of the aids here named are used in commercial cleaning compounds. In order to avoid their misuse, always apply such compounds strictly according to directions and only for the purposes and conditions specified.

Many of these aids also can be obtained in commercial form under other names. Impure carbon-tet is used in fire extinguishers; mixed with kerosene or naphtha it is found in popular dry cleaning and stain removing compounds. Acetone is a component of many film cements and is found also in nail polish remover and in varnish and lacquer removers.

Revised Audio-Visual Booklet

National Audio-Visual Assoc., 845 Chicago Ave., Evanston, Ill., is out with a new revised edition of "Current Models of Projection Equipment." Copies are \$1 each, postpaid.

The 12-page pamphlet contains up-to-date specifications and prices for the projection equipment manufactured by 40 companies. It includes a total of 186 models of projection equipment classified as follows: 39 16-mm. sound projectors, 15 automatic projectors, one microscopic projector, 15 opaque and combination projectors, 11 overhead projectors, 80 slide and filmstrip projectors and 25 sound slidefilm projectors.

U. S. Dominance in World Film Mart

Approximately 74% of all feature films shown in the world's theaters are made in the U. S., reports the Dept. of Commerce. About 38% of total motion picture profits are derived from foreign showings, with about \$100 million remitted to the U. S. annually.

THE NATIONAL CARBON

TRADE-MARK

ARC'S BIG FIVE:

- ★ small-source size
- ★ terrific brightness
- ★ great power from one unit
- ★ white light
- ★ minimum heat per foot-candle

make it indispensable on movie sets!

THE "National" carbon arc offers an ideal combination of the qualities most desirable in a studio light. The carbon arc's small-source size — less than one quarter square inch — insures sharp shadows, simulates one-source lighting better, creates a perfect "follow-spot." The carbon arc's high brightness penetrates deep sets, establishes high light levels without excessive heat, creates better the illusion of a third dimension. The carbon arc's great power from one unit cuts illumination pathways through general set illumination, boosts daylight, lights large sets so generously that camera-lens apertures may be reduced and great depth of focus obtained. The carbon arc's white light matches outdoor shooting conditions, lends itself better to filters because it has equal quantities of blue, green and red and, finally, makes colored objects appear visually the same inside and outside.

There is no substitute for the carbon arc.

**MORAL: YOU CAN'T SKIMP ON STUDIO LIGHTING
WITHOUT RISKING BOX OFFICE!**



***When you order studio
or projector carbons—
order "NATIONAL"!***

The term "National" is a registered trade-mark of
Union Carbide and Carbon Corporation

NATIONAL CARBON COMPANY
A Division of
Union Carbide and Carbon Corporation
30 East 42nd Street, New York 17, N. Y.

District Sales Offices: Atlanta, Chicago, Dallas,
Kansas City, New York, Pittsburgh, San Francisco

IN CANADA: National Carbon Limited
Montreal, Toronto, Winnipeg

Proposed Lantern-Slide, Slidefilm Standard

Numerous suggestions have been received by the American Standards Association following the circulation in the field for the usual period of one year of the proposed American Standard for Lantern Slide and Slidefilm Projection. This proposed standard (Z38.7.20), first promulgated on June 1, 1950, will now be reconsidered by the proper committee, with final recommendations expected shortly.

Anybody having any suggestions to offer anent this proposed standard is urged to communicate *immediately* with the ASA at 70 East 45th St., N. Y. City, 17. The proposed standard follows:

1. Screen Illumination

1.1 The illumination on the screen should be adequate to give at least 5 foot-lamberts.

1.2 The projector illumination should be maintained to give the illumination indicated in Fig. 1 for beaded or matte screens of the size required to meet the other items of this standard.

1.3 Screen lumens shall be measured according to Section 3.4 of American Standards Methods of Testing Printing and Projection Equipment, Z38.7.5, 1948.

2. Screen Maintenance

2.1 When the illuminated screen appears darker than a clean piece of white typewriter paper held in contact with the screen, the screen should be cleaned, resurfaced, or replaced.

3. Use of Beaded-Type Screens

3.1 The front row of seats shall be

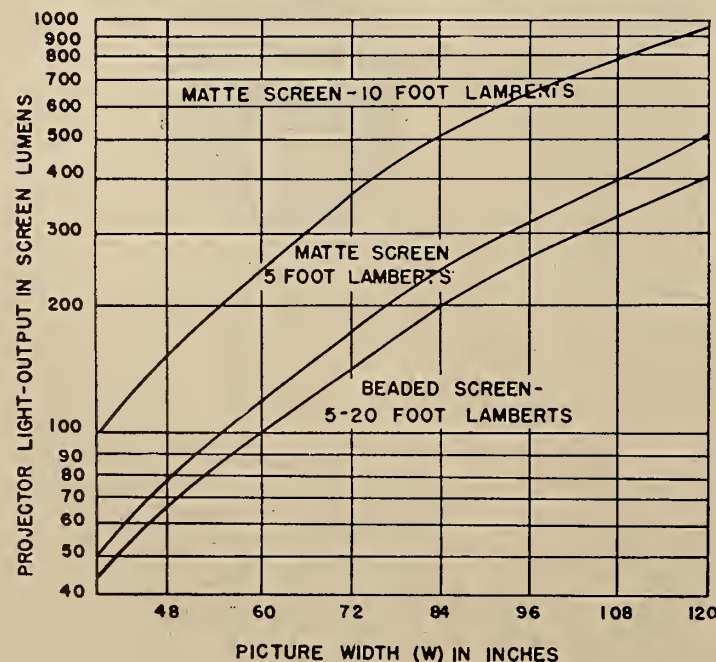

FIGURE 1
Showing the maximum recommended picture widths for projector light output.

at least $2\frac{1}{2}$ times the width of the screen away from the screen.

3.2 The back row of seats should be not more than 5 times the width of the screen away from the screen.

3.3 The outer row of seats on each side should be not farther than 20 degrees from a line connecting the projector and the center of the screen.

4. Use of Matte-Type Screens

4.1 The front row of seats should be at least two times the width of the screen from the screen.

4.2 The back row of seats should be not more than five times the width of the screen away from the screen.

4.3 The outer row of seats on each side should be not farther than 30 degrees from a line connecting the projector with the center of the screen.

5. Room Illumination

5.1 During the projection periods the illumination of the room should not exceed 0.1 foot-candle. The room lights should be arranged so that no direct light from them reaches the screen. Dimmer circuits for providing a graded transition of lighting are recommended for auditoriums and classrooms.

Tips on Non-Theatrical Movie, Slidefilm Showings

Many very helpful hints anent the various factors affecting the success of non-theatrical movie and slide projection are contained in a recent bulletin issued by Da-Lite Screen Co., Chicago 39, Ill. Of prime importance is the use of the right size and type of screen for a given show-

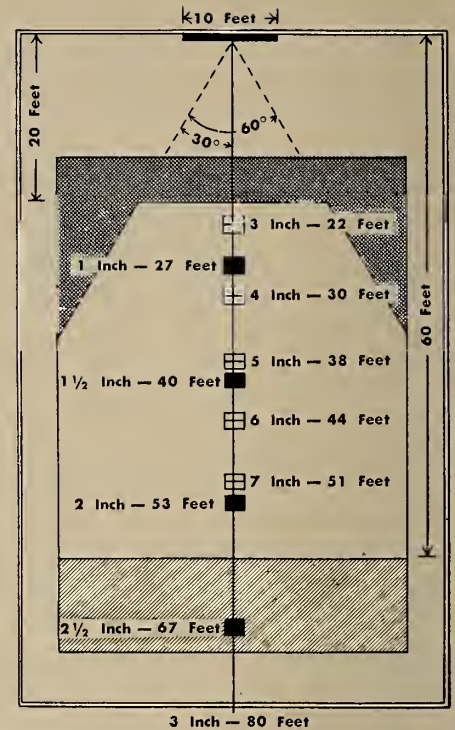

Da-Lite screen viewing chart, Open, ruled squares relate to the positioning of a 35-mm slide projector, with various lenses; solid black squares relate to a 16-mm motion picture projector, with various lenses. Unshaded portion denotes, of course, preferred viewing area.

ing, and to this end Da-Lite provides the accompanying handy chart.

A simple formula used by many audio-visual specialists recommends a minimum viewing distance of twice the screen width, and a maximum viewing distance of six times the screen width. To apply this 2 x 6 formula as illustrated by the chart, divide the maximum viewing distance (back row of seats) by 6. The result is recommended screen width. If a square screen is to be used, height will be the same as width. In rectangular screens the height is automatically established on the basis of a 3 x 4 proportion. In cases where the available projection lens does not fit the recommended screen size, it may be necessary to use a longer or shorter focal length lens.

To find the exact screen size: aperture width x projection throw ÷ lens focal length = width of screen needed. For example: Aperture 0.38 (16-mm movie projector) x 26 feet (projection throw—desired distance from screen) ÷ 2 (lens focal length) = 4.94 feet, or approximately 58 + inches. Thus one would use a 45 x 60-inch screen.

Copies of this bulletin and other Da-Lite projection aids are available for the asking.

Scientific Film Show at The Hague

The Fifth Annual Congress of the International Scientific Film Association will be held in the Municipal Museum of The Hague, Holland, from Sept. 15 to 22 next.

Projection Rooms

Around the World

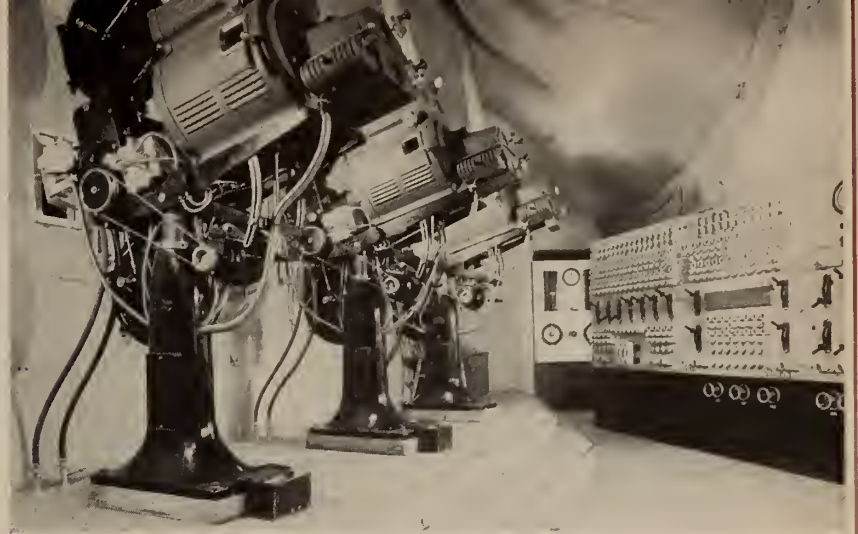

SPACIOUSNESS, UTILITY MARK THIS SWEDISH ROOM

A most interesting installation in the China Theater, Stockholm, showing belt-driven Ernemann projectors mounted on an elevation, and, at rear right, control panels for all power and light in the theater. Cleanliness is a "must" in all Swedish projection rooms.

PROJECTION IN THE ANTIPODES

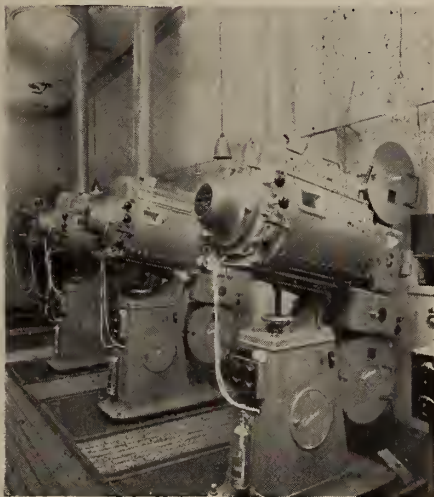

Comparing favorably with America's best is this projection room in the Regent Theatre, Melbourne, Australia. Complete installation by Westrex, including Australian-made arc lamps of indubitable American design much like the Peerless.

NO TENT SHOWS: PROJECTION ROOMS IN THE STRAITS SETTLEMENTS

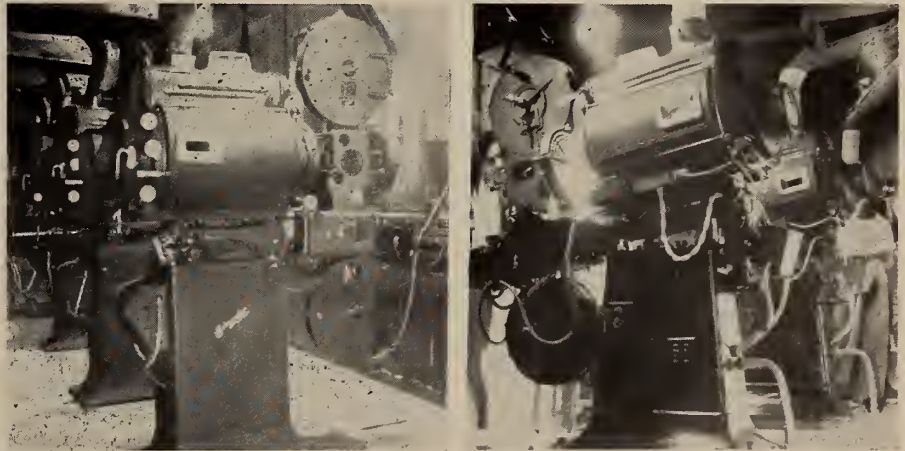

Capitol Theater, Singapore (left): Simplex E-7 projectors and sound equipment, Peerless lamps, Brenkert effect projector, Rect-O-Lite rectifiers. The largest in Singapore, this theater was opened in 1929. Note "surface wiring." The Rex Cinema, Singapore (right): Super Simplex projectors, RCA sound, Peerless lamps, and tungar rectifiers.

CINE METRO, LIMA, PERU

This closeup of front room wall evidences typical Loew planning and attention to detail.

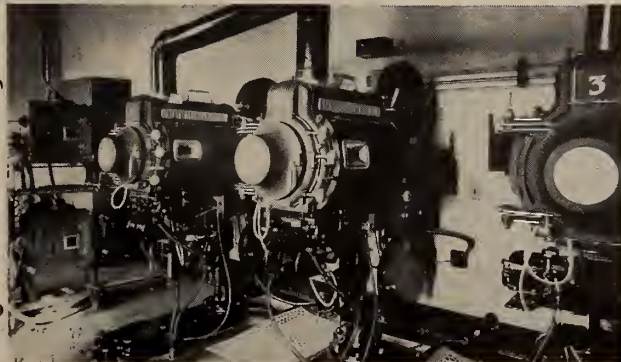

METRO PASSEIO, RIO DE JANEIRO

This sleeper-jump from projectors to amplifier rack suggests possible future conversion of room to a skating rink.



IN THE SPOTLIGHT



By
**HARRY
SHERMAN**

LAST month we presented a few suggestions about the individual's Social Security status, in the course of which we mentioned that, in the event of retirement, there were *three* kinds of benefits available, and that in the event of death there were *five* elective courses for a man's family. We advised consultation with the nearest S. S. field office by anybody interested, assuming that this was the easiest procedure.

Not so. We've had many requests for details of these various forms of benefits. So here goes, although we still favor a personal visit to the nearest S. S. office.

S.S. Retirement Benefits

During your retirement, three kinds of benefits are available. These are:

1. The primary amount, which is the monthly sum paid to a retired man himself, beginning at age 65 and continuing for life. This ranges from \$20 to \$80 a month.
2. The wife's benefit, which is half of the primary amount, paid to the man's wife during her lifetime if she qualifies. A man and wife together may receive \$120 a month or \$1440 a year.
3. The child's benefit, also half the primary amount, paid to a qualified child, usually until the age of 18. The maximum benefit to a family is \$150, or \$1800 a year.

S.S. Death Benefits

A family is entitled to one or more of five possible S.S. benefits, if the head of the family dies. They are:

1. Widow's benefit: a monthly payment of three-quarters of her husband's benefit.
2. Mother's benefit: a monthly payment of three-quarters of the primary amount paid to a widowed mother having a qualified child in her care. (She may receive either the widow's benefit or the mother's benefit, but not both).
3. Child's benefit: three-quarters of the primary amount for one qualified child. If there are two or more qualified children, each receives one-half of the primary amount and another one-quarter is divided among them.
4. Parent's benefit. In some cases, a parent is entitled to three-quarters of the primary amount.
5. Lump-sum benefit. Under the new law, whenever a fully or currently insured person dies, a lump sum amounting to three

times the primary amount is paid to cover funeral expenses.

If a retired worker earns more than \$50 a month as an employe or in self-employment, he and all those receiving benefits through him are cut from the S.S. rolls. An exception is the 75-year-old worker, who may earn as much as he pleases without the loss of any benefits.

Incidentally, veterans of World War II are credited with having earned \$160 a month during the period of their service.

- The membership of Local 253, Rochester, N. Y. turned out en masse at a breakfast party given in honor of their president, Louis Levin, and Fred Boekhout, their business representative. Beautifully inscribed cigarette lighters bearing the IA emblem were presented to Lou and Fred in appreciation for their long service to the Local.
- New York City Local 306 has insured its members for complete medical care through the Helath Insurance Plan (HIP) of Greater New York. Under this plan, about 2300 members and their wives will receive comprehensive medical, surgical and specialist care at their homes, at the offices of doctors chosen by the members themselves, in HIP medical centers, and in hospitals. In addition, they will be entitled to laboratory tests, X-ray examinations, visiting nurse service, and ambulance transportation.

The HIP premium is paid out of a 5% contribution to the Union welfare plan by employers, who make this contribution in lieu of a wage increase direct to the members. The first group of members began to receive this service last February; the other members will benefit from this plan as soon as additional employers contribute to the fund.

The foregoing brings to mind an item we read in a recent issue of the *United Mine Workers Journal*, and which is in direct contrast to the services rendered by HIP. Asked about the doctor situation in his area, a Kentucky miner told this story: "My wife was about due to have a baby. I went to the doctor's office four times and asked him to come down

and see her. Each time he gave me some excuse. The fifth time I took my snub-nose (a small pistol, in Kentucky parlance) along and brought him back with me." The ironic part of this story is that the doctor had a contract with the union to which the miner belonged and was handsomely paid through the checkoff system for his services to the miners.

- We were sorry to hear that Bill Maxon, member of Syracuse Local 337 and vice-president of the AF of L Union Label Council, has been ailing for the past few weeks and has been ordered by his doctor to forego all activities for a spell. We hope it will not be long before Bill is back in harness and pitching on all fronts.
- The Wage Stabilization Board heard arguments recently on behalf of the Hollywood AF of L Film Council and its affiliates (including the IA, American Federation of Musicians, and the American Federation of Radio Artists) that wages in the motion picture industry should not be frozen since no controls exist over theater admissions and film rentals. Robert W. Gilbert, representing the film unions, told the Board that the Defense Production Act of 1950 does not authorize wage controls in industries exempt from price controls. "If this panel cannot find an express authorization for regulation," said Gilbert, "then the panel must resolve that doubt in favor of no regulation."

The panel, headed by Chairman Theodore Kheel, includes two labor members, one of whom is Woodruff Randolph, president of the International Typographical Union. Findings and recommendations on the problems of wage stabilization in the industries exempt from price ceilings will be made after further study. Industries exempt from price control are motion pictures, railroads, communications, trucking, insurance, public utilities, real estate, airlines, local transit companies, newspaper printing and publishing, radio broadcasting and television.

- Some 30-odd years ago, when we were financial secretary of New York Local

306, our sidekick at that time was Joe Hornstein, who was the union treasurer. "Hoboken Joe," as he was known to his fellow projectionists, was extremely popular with his brother craftsmen. When he founded the Joe Hornstein Motion Picture Theater Supply Co. some years later his success was assured from the start. Joe's sudden death last month was a shock to his many friends in and out of the motion picture industry. His business interests will be carried on by his three sons.

- More than 1300 delegates attended the New York State Federation of Labor Convention, held last month in Buffalo, N. Y. This is a record attendance in the history of the State organization. The meeting followed the annual 10th District Convention, and many of the IA delegates remained for the State Federation conferences.

William Green, president of the AF of L, and George Meany, AF of L secretary-treasurer, were among the speakers. Ralph Wright, U. S. assistant secretary of Labor; Charles Halloran, president of the Buffalo Federation of Labor, and Harold C. Hanover, secretary-treasurer of the N. Y. State Federation of Labor also addressed the gathering. Topics discussed by the various speakers included the Taft-Hartley Law, the Hughes Brees Unemployment Insurance Law (see IP for May, 1951, p. 17), and Communism. Needless to say, these topics were subjected to considerable criticism and were roundly denounced by the speakers and the delegates.

Among the IA men present at the State Federation meeting were IA President Walsh; James J. Brennan, IA 4th vice-president; H. Paul Shay, 10th District secretary; J. C. McDowell, Solly Pernick, N. Y. Local 1; Herman Gelber, Edward Stewart, N. Y. Local 306; Tom Murtha, Brooklyn Local 4; Tom Brogan, Auburn L. 119; Kenneth Bassler, Niagara Falls Local 121; Donald Rood, Utica Local 128; Bert Ryde, Buffalo Local 233; Fred Boekhout, Rochester Local 253, Ralph Halloran, Elmira Local 289; Edward Wendt, Albany Local 324; George Raaflaub, Syracuse Local 337; Earl Tuttle, Binghamton Local 396; John Short, Corning Local 480; and Gerald Henderson, Batavia Local 581.

- William Monroe, Jr., 52, and Frank K. Carlin, 59, members of Atlantic City Local 310, died recently within 10 days of each other. Monroe, who was financial secretary-treasurer of the Local, succumbed to a heart attack on June 26; and Carlin, a charter member of the Local, died July 5 from a stroke suffered two weeks earlier. Both men were veterans of World War I.

- Recent out-of-town visitors to the

offices of IP included Walter Roberts, Local 178, Salisbury, N. C.; Mike Ostrowski, Local 233, Buffalo, N. Y.; James Manion and Charles Serkes, Local 143, St. Louis, Mo.

- Jake Pries, former secretary and business representative for Atlanta Local 225, informed us that his son, Ralph, presented him with a third grandchild—a girl. Young Pries formerly managed the Philadelphia branch of the National Theatre Supply Company, and is now associated with the Berlo Vending Machine Co.

- Existing and projected employe benefit plans in the motion picture field look a little pallid when compared with the following example of enlightened business management:

Eastman Kodak employes leaving for military service receive a special allowance equal to four weeks' pay if with Kodak a year; two weeks' pay if with Kodak six months. If eligible for a vacation at the time he enters service, he will receive his normal vacation pay.

His group life insurance will be continued for a period of six months after he leaves; it will be put back into effect immediately he returns to Kodak. He will receive a wage dividend payment in the year subsequent to leaving, the amount to be about the same as if he had not been away. On rejoining Kodak, his eligibility under various Kodak plans will be the same as if he had not left. Time spent in the service will be counted toward his service record. He will be credited with retirement annuities for the time he is in service.

Kodak will assume, on a year-to-year basis, the cost of family hospitalization, if such a contract were in effect at the time of departure for military service.

- We were saddened to learn of the recent death of Charlie (Sheriff) Hunt, 74, member for over 50 years of Detroit Local 38. Charlie was a charter member of Local 38 and worked in many of Detroit's theaters until about a year ago, when he retired because of ill health. Many stagehand and projectionist road men will remember Charlie as the stage carpenter at the Gayety, Avenue and Palace theaters.

- Little Rock, Ark. Local 204 celebrated its 40th anniversary with a dinner-dance at the Hotel Marion, Little Rock. About 175 persons participated in the affair, which was one of the most successful ever held by the Local. Representing the IA were General Secretary-Treasurer Wm. P. Raoul; Charlie Hathaway, IA representative and business representative of Oklahoma City Local 112, and Al S. Johnstone, New Orleans Local 293, representing President Walsh, who was

unable to appear. Acting for the Local, Raoul presented charter members J. B. Cowpland and Noel Withrow with diamond lapel pins.

Sam M. Wassell, mayor of Little Rock, C. K. Call, State labor commissioner, and S. P. Dixon, deputy labor commissioner, were among the invited guests.

- The 7th District held its annual convention last month at the Henry Grady Hotel in Atlanta, Ga. N. L. Liggett, president of Atlanta Local 225 was the presiding officer. Gov. Herman Talmadge, G. Simons, representing the mayor of Atlanta, Henry W. Chandler, president of the Atlanta Federation of Trades, and J. B. Pate, president of the Georgia State Federation of Labor were among the prominent speakers. A banquet in the Dixie ballroom of the Henry Grady Hotel closed the sessions.

- The Tri-State (Pennsylvania, West Virginia, and Ohio) Association held its 27th annual meeting last month at the Elk's Home in New Kensington, Penna. F. P. (Reel) McCoy, secretary of New Kensington Local 444, was unanimously reelected secretary of the Association. President Walsh and other top IA executives addressed the meeting.

Among the guests of honor were Harry J. Abbott, 8th IA vice-president; Lawrence J. Katz, IA representative; N. Williams and Harry Russell, National Theatre Supply Co.; Tom Cocklin, National Carbon Co.; and Frank Hamre, Radio Corp. of America. Delegates from Pennsylvania Locals included Paul Ferry, William and Luther Thompson, Pittsburgh Local 171; Emory Myers, York Local 283; Sam Rubin, Harrisburg Local 488; Roy Bryan, Altoona Local 130; Wm. McClay, Uniontown Local 208, and Frank Karalfa, Johnstown Local 561.

Supply Dealers Sign For Altec Service

With the continuing expansion of electronic developments in the motion picture industry, theater supply dealers are becoming acutely aware of the need for qualified sound engineering advice, reports Altec Service Corp. Latest to join the Altec fold is Ringold Theater Equipment Co., Grand Rapids, Mich.

Renewal agreements for Altec service were signed recently by GerOBar, Inc., Indianapolis; Ohio Theater Supply Co., Cleveland, and McArthur Theater Equipment Co., Detroit.

Tv Set Implosions Negligible

When Tv was new, there was a great deal of fear that picture-tubes would implode and do damage and injury. But to date, after 15,000,000 sets have been in use, there are authenticated cases of only one or two actual "implosions." So the hazard ratio seems almost negligible.

Wide Technical Gains in 1950

SMPTe Progress Report Details Film, Tv Advances*

PROGRESS in the motion picture studios during 1950 was highlighted by the advances in various color systems and the apparent acceptance of color for pictures of all classes and types. The taking speed of the Technicolor system has been increased considerably. Several laboratories within and without studios, have been remodeled to handle the various other color systems which are now in active use.

The drive for production economies continues and a number of different things have been tried with varying success. During 1950, radio communication facilities were used extensively between studios and location units, as well as for the control of production personnel and equipment. The F.C.C. allocated radio channels to the motion picture industry specifically for this purpose. Closer pre-picture planning among the production groups, resulting in the reduction of shooting-days per picture, has probably been the greatest money-saving factor.

100-Theater Light Survey

In picture and sound reproduction the work of the Screen Brightness Committee has created a great deal of interest among studio personnel, and the results of the 100-theater survey promise to bring about a better relationship between negative density, print density and average projection light.

The various Tv broadcasters are continuing with the policy of moving into studios where space limitation is not such a serious factor.

The use of motion films in Tv has grown steadily throughout the year. Already a considerable number of shows are being filmed, and there are indications that the majority of the sponsored shows may eventually be broadcast from film. Much of this shooting is being done by independent producers, but with increased studio space some Tv companies are preparing to film their own productions.

35-mm Photography Advances

Zenith Phonovision system has been undergoing a consumer test with the permission of the F.C.C. These tests have used 35-mm films produced for theatrical release. The prints have been regular color releases, or regular black-and-white releases, as well as special black-and-white prints made to Zenith's specifications of density and contrast.

By July of 1950 conversion to safety film was approximately 85% complete. Eastman discontinued the manufacture of 35-mm nitrate positive film for motion pictures. Some Eastman safety stock is being used by Du Pont pending production of a suitable safety stock by the latter company.

The Eastman 35-mm negative-positive color process, introduced experimentally in 1949 has now been used in a number of full-length pictures.

Intense Color Activity

One studio is shooting pictures with Eastman color negative, viewing dailies on Eastman color positive, and will release on SUPERCineCOLOR three-color print stock.

A second studio has made a feature picture on Eastman color negative and will release on Du Pont color print stock.

Another studio is shooting a feature picture on Ansco negative-positive and is doing all of the processing in the studio.

Other studios are preparing to produce some of their own color films by any one or more of the aforementioned processes, or by shooting on black-and-white stripping film and using the three-color separations for printing on any one of the print stocks.

Cinecolor Laboratory Report

In laboratories in the color field, Cinecolor Corp. reports the following:

(1) Installation of equipment and production processing of the Eastman color negative film.

(2) Installation of equipment and production processing of the Eastman color positive film (with sound).

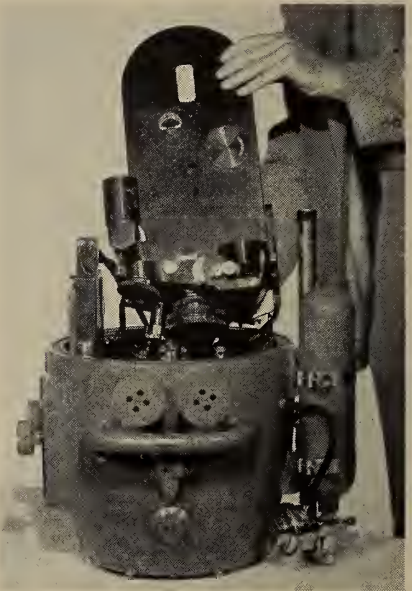

The Aquaflex underwater photographic unit.

(3) Full scale conversion for the SUPERCineCOLOR three-color release printing.

Consolidated Film Industries has equipped both its Fort Lee (N. J.) and Hollywood laboratories for production of Trucolor. The company is now in release production of the new three-color Trucolor prints. The print stock is Du Pont three-color material type 875, and the original negative is the Eastman automatic masking three-color film type 5247.

The sequential operations are: three separation prints on panchromatic film from the color negative, three duplicate negatives optical effects incorporated, on gray base stock through selective filters from these prints which are then printed through proper filters for layer selectivity, on the multiple-layer Du Pont print stock.

Du-Art Laboratories in New York will

Eclair "Cameflex" takes 35-mm and 16-mm film interchangeably by changing film magazines.

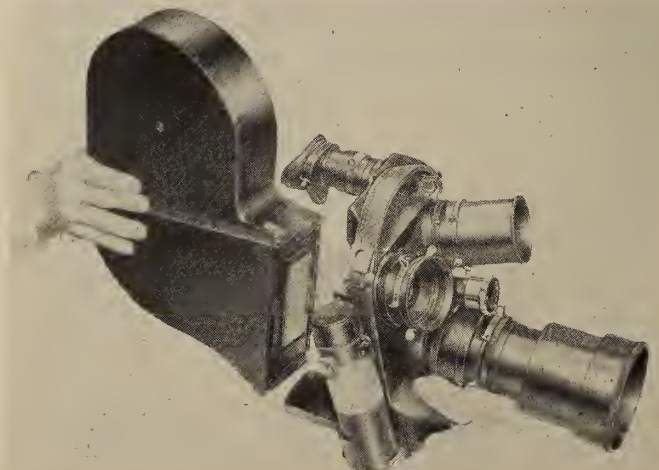

* J. Soc. Mot. Pict. & Tv Eng., May 1951.

make "Tri-Art" color on Eastman, Ansco, and Du Pont color materials.

Technicolor is at present working with films for the three-strip cameras which are balanced for a color temperature of approximately 3350 K. It is claimed that this system will bring illumination requirements within the range of that now used for black-and-white photography. The system will be available for general use within a few months.

Lighting Equipment, Techniques

Technicolor announced a change in color balance of the three-strip system from that of sunlight to a color temperature of approximately 3350 K. This resulted in the production of gelatin-type filters for the carbon-arc lamps to reduce their color temperature sufficiently for them to operate in conjunction with unfiltered tungsten lamps.

This change is at present in the transition stage. Some time ago the Technicolor system was increased in speed by a ratio between 450 ft-c and 300 ft-c key-light on a white light, or sunlight, basis. Later, by going to a 3350 K basis, a further increase in speed to 150 ft-c was announced. This latter increase in speed is, however, applicable only to incandescent tungsten lamps, because it is necessary to filter the high-intensity carbon arcs by approximately the amount gained in order to provide a color balance.

At the time of completion of this report only tests and picture sequences have been completed with the 150-ft-c system balanced for 3350 K. Productions have been made with the 300-ft-c white light system.

While no mercury-cadmium lamps are in present use for set lighting in the West Coast studios, the bulbs are available and are being evaluated.

Reflector-type incandescent bulbs, such as photoflood and photospot lamps, have been increasingly used on location where

the documentary type of lighting is indicated and for non-theatrical releases.

Cameras and Accessories

A system for special effect shots has been devised and applied at present to panning and tilting the camera, which permits the cameraman to pan and tilt the camera in a normal manner and follow the action as desired. A record is made of the movement and, for subsequent exposures on the same film, the record controls the camera movement, matching the original relation between the camera position and picture frame during these subsequent shots.

In France, two new lenses were announced. "Retrofocus," a very short focus lens designed so as to permit attachment and use on normal 35-mm cameras, and "Erax," a highly corrected lens developed by Société Kinoptik in which the graduation of the aperture of the diaphragm is proportional.

The Eclair Camerette, introduced in the U. S. from France in 1949, now has a companion model, the "Cameflex," which takes 35-mm and 16-mm film interchangeably.

Navy's Underwater Photography

The "Aquaflex" was introduced in the U. S. in 1950, the first one being used by the U. S. Navy. Essentially, it is a standard 35-mm Camerette with a specially designed magazine in an underwater blimp which permits external stopping and starting, speed control, focus and diaphragm changes.

A compressed cylinder attached to the underwater housing, working on a demand valve, maintains an internal pressure of 3 psi above the external pressure, irrespective of the depth to which the camera is submerged. Stabilizing fins allow the camera to be moved through the water smoothly. The camera and housing weigh about 100 lbs. when out of the water.

Great flexibility of operation is at-



RCA theater television projector mounted on front of theater balcony.

tained by using diving equipment with self-contained air supply for the operator. While propelling himself and the camera by means of swim fins attached to his feet, the cameraman, unaided, can maneuver the camera and operate aperture and focus controls. Smooth travel shots, following divers or native fish down to a depth of 80 ft., have been shown before the Society.

35-mm Sound Recording

The year 1950 has seen noteworthy progress in the application of magnetic recording to motion picture production. The extent of the application has varied among the producers from cautious planning and preliminary experimentation, with the view of future conversion, to complete conversion to magnetic recording on all production and music recording work.

While many advantages with respect to quality of production, maintenance and operation of equipment, and conservation of film raw stock accrue from the use of magnetic recording, the overall recording operation, from the original recording of dialogue and music to the production of the final release print, has been considerably complicated. As a result, many of the extensive claims of great economies to be effected by the use of magnetic recording have been considerably modified, and conversion programs are now more in the nature of plant modernization.

The great demand for smaller and lighter portable equipment for location, has been, possibly, the strongest influence in affecting the choice of magnetic recording, as magnetic-recording

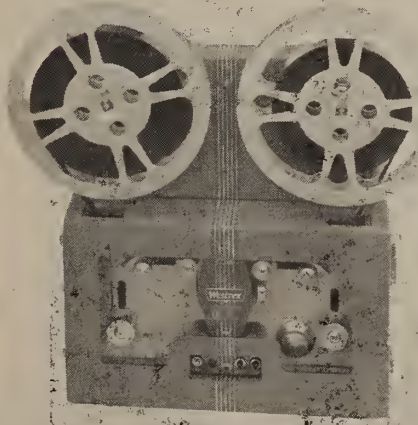

The Westrex portable magnetic sound recording system, introduced recently.

equipment has been the answer to this problem.

Various Magnetic Applications

Since April 1, 1950, all Paramount production, both in the studio and on distant location, has been done on super-portable recording channels, weighing 65 lbs. and using 17½-mil recording stock.

New portable magnetic-recording systems for 35-mm, 17½-mm or 16-mm film, featuring compact, light weight construction, were introduced by Westrex, and are now in wide use in studios both here and abroad.

The use of magnetic equipment and re-recording has gained momentum. It has become the practice in a number of studios to record rehearsals on magnetic film. A good "rehearsal" becomes a "take" and unsatisfactory "rehearsals" are erased. The "take" can be reviewed at any convenient time and then transferred to photographic film for release printing. In this connection, a multi-track magnetic equipment has been used to good advantage.

This equipment records one, two or three tracks on the same film strip on which music, speech or sound effects, or any combination thereof, can be recorded with the same relative volume variations as they have in the finished product. The benefits of this equipment, as experienced by Columbia Studios, follow:

Summary of Advantages

Saves track storage space by a factor of about 10 to 1.

Reduces the cost of foreign versions by 50%.

Provides a ready means of furnishing duplicate release negatives as needed.

Provides a convenient source of material for Tv versions "minus music" and it provides a source from which dialogue, music and effects can be rebalanced in the dubbing of 16-mm versions.

The increased use of magnetic production recording, together with a lack of suitable means of editing this material, has resulted in the development and use of equipment to make direct-positive photographic duplicates of the magnetic recordings for use by film editors.

Re-Recording Procedure

Re-recording is being done in some studios directly from magnetic tracks, and in some, from photographic duplicates. Photographic duplicates may be either direct positives or electrical transfers to a photographic negative from which re-recording prints are made.

The Signal Corps Studios have applied several modifications to standard magnetic recording systems, which provide improved operating efficiency as

well as economies in time and material. These include facilities for:

(1) Stopping, reversing and restarting recorder, recorder and projector in interlock, and (2) silently changing over from record to playback, or vice versa, while running. Thus, errors in narration and re-recording jobs may be corrected without rethreading, splicing or blooming the film. Also, this studio has perfected a method for lip-synchronous production which makes use of 35-mm magnetic loops.

The year 1950 has seen continued and extended use of nonsynchronous, sprocketless-type magnetic recording equipments, particularly in the field of radio transcription. There have been a number of schemes that have been developed to make these equipments operate synchronously with picture film for use in Tv and for cue-track recording.

Last year also saw the use of low-shrinkage safety-base film extended to sound recording. By the end of the year practically all photographic recording was being done on acetate-base stock.

16-mm Photography, Recording

AnSCO has marketed a new 16-mm color duplicating film. AnSCO's new film Type 238 is designed for making dupli-

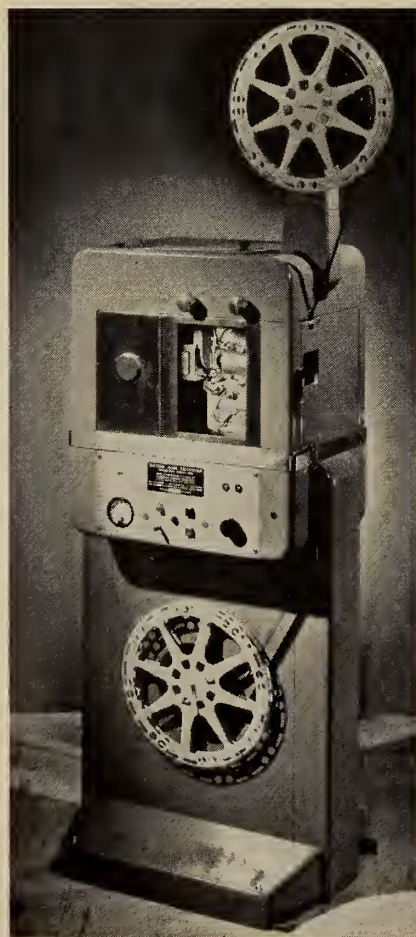

Eastman Kodak 16-mm television projector, Model 250, in one self-contained unit.

cates with soft gradation color originals.

The Naval Ordnance Lab. has developed techniques in the high-speed photography of underwater explosions. Pictures ranging from 2,000 to 3,000 frames/sec have been made of explosions of charges up to 1 lb., at depths down to 2 miles.

Early in 1950 a new 100-ft.-film capacity, 16-mm, single-system sound-recording camera called the "Cine-Voice" was introduced by the Auricon Division of Berndt-Bach, Inc., of Hollywood, Calif. It is available with a galvanometer for recording either variable-area or variable-density high-fidelity sound track to SMPTE Standards.

The camera weighs only 12 lbs. and the entire equipment, including amplifier, microphone, cable, headphones, accessories and carrying case, weighs 34 lbs. It operates from either constant speed or synchronous motors. A portable power supply to drive the camera from an ordinary 6-volt storage battery is also available.

16-mm Magnetic Recording

The RCA type RT-11A magnetic tape recorder was built for professional service and is being used widely in the broadcasting and Tv fields. It has also found limited acceptance in motion pictures for recording projection takes.

Comparatively little use was made of 16-mm magnetic film, although recorders were available.

Reeves Soundcraft Corp. introduced a service for edge-coating 16-mm raw stock or developed film with magnetic material to permit the use of magnetic sound tracks with 16-mm prints. Excellent sound reproduction from such prints was demonstrated, using a modified projector.

J. A. Maurer, Inc., demonstrated a new multiple-track 16-mm sound-recording system that reduces distortion resulting from nonuniformity of the projector sound-scanning light beams.

35-mm Film Sound Reproduction

The activities of the Screen Brightness Committee in obtaining accurate information on a group of 100 theaters throughout the country has already had an effect on the motion picture studio laboratories, where the preliminary information is being used to determine if changes should be made in print density.

In at least one studio it was found desirable to increase set lighting levels slightly in order to improve the projection quality of the prints.

This work promises to bring about a much better correlation between production and exhibition both as to print quality and projection conditions.

At least two new mirror-type carbon-

(Continued on page 26)



TELECASTS

TELEVISION developments of particular interest to the motion picture theater field during the past month were so numerous and varied as to leave both the Tv broadcasters and theatermen in a continual dither. Unfortunately for the theater field, not all the happenings were on the right side of the ledger. To recap:

The second closed-circuit telecast of a boxing match between Jake La Motta and Bob Murphy was made to 11 theaters in 9 cities and was a box-office wow. Within a few days after the bout RCA reported that orders for large-screen theater Tv units were coming in "from left and right" and that the year-end goal of 100 installations appeared a certainty.

200 Equipments On Order

RCA now has 200 theater Tv orders on hand and estimates that within six months the total will exceed 400. A warning note was sounded by a Loew executive, who said: "Still to be answered is the question of what will happen when more than one theater in a locality has the facilities to carry such sporting events. Full houses are not likely to be the rule when that happens."

On July 12 the theater Tv showing of the Rex Layne-Rocky Marciano bout was also a box-office bonanza.

Bad news for theaters was the request of the Society of Independent Motion Picture Producers for FCC approval of subscription Tv—that is, a pay-as-you-see service. Precedent is the FCC denial some years ago of subscriber-fee radio programs.

Actors Guild Makes Move

The Screen Actors Guild will enforce the clause in its basic contract with the studios which bars the showing on the air of any film made after Aug. 1, 1948.

Leaders of the Theater Owners of American and Allied States, which have been at odds as to which band of the spectrum to press for at the FCC hearings on allocations set for Sept., finally agreed to request UHF channels.

Cowboy star Roy Rogers obtained a temporary injunction preventing Republic Pictures from disposing of 78 films to the Tv networks.

An Exhibitor Point of View

Abram F. Myers, board chairman and general counsel for Allied States exhibitors, observed: "The stampede to-

ward large-screen Tv is only natural, but there remain several vexing questions as to the ultimate effect of theater Tv, particularly as it may affect the standing of the theater in the community.

"The cost of a television installation is very high," he pointed out. "There is a dearth of first-class fighters. The attitude of other sports toward theatre Tv has not crystallized. The public reaction to having to pay for programs which were promised for free remains in doubt.

"The ultimate effect on regular movie attendance is not known. And, of course, there are still the same old uncertainties as regards systems and channels." Mr. Myers emphasized the possible danger of "turning theatres into prize fight arenas from time to time.

"One cannot escape wondering what typical movie-goers—say parents, persons of refinement and children—will think of such goings on. Will they be willing to space

their movie-going to avoid these brawls, or will the theatre lose caste in their estimation? The experience would hardly endear the theatre to them as a place of polite entertainment."

Also, the Allied official continued, as soon as the fight ends the audience rushes for the exits "leaving the theatre empty and exposing motion pictures to an unwarranted humiliation." He cited the lack of good fights and the possibility of eventual complaints to the FCC.

Out of the welter of events emerged the firm conviction by well-informed motion picture men that the greatest menace to the film theater box-office still is the possibility of FCC approval of pay-as-you-see Tv programs sent into the home. The tremendous revenue obtainable from such a system would make it unnecessary to obtain advertising sponsorship of programs.

GPL's 'Simplex' Direct-Projection Theater Tv. System for Distribution by National Theater Supply

FURTHER impetus to the rapid expansion of theater Tv was supplied by the announcement (July 9) of a direct-projection system designed and manufactured by General Precision Laboratory for distribution through National Theatre Supply Co. Orders for

this new unit, to be known as the Simplex Theater Tv System, are now being accepted for late Fall delivery.

An outstanding feature of this system is an improved mirror design which gives a balanced light distribution over the entire screen. GPL promises that the trade showing scheduled for early August will reveal that the system delivers illumination at the corners of the screen in the ratio of 80% of that at the center, the eliminating "hot spot" center glare. Overall definition is rated as excellent over the entire screen area.

Whose Ox is Gored?

The *Kansas City Star*, powerful mid-west newspaper, attacked the exclusive theater telecasting of boxing matches, declaring that "the families owning 13,000,000 Tv sets have a right to feel cheated at being denied the pleasure of a sports program which otherwise would have been brought into the homes of most of them."

Admitting that there was no contract to this effect when the Tv sets were bought, the *Star* said people "assumed" they would be able to see as well as hear the major sports events.

This, from a representative member of the national association of newspaper publishers which, when radio was burgeoning, tacitly agreed among themselves not to publish radio program listings because it might hurt *their* business.

The advertising-free theater Tv presentations, requiring no aspirin, are as a breath of fresh air compared with the nausea-inducing columns of any metropolitan newspaper.

Simplex Tv Technical Data

The projection tube has a suspension mounting that permits removal for cleaning without disturbing the positioning adjustment. The tube is suspended from the top of the barrel, and the tube mounting bracket may be removed through the top with the tube in place. All adjustments and controls for the barrel are at the top, easily adjustable without using ladders or catwalks.

A re-circulating system for cooling the optical barrel, rendering it dust-proof, is provided. The same cooling system controls the humidity in the barrel and eliminates arc-over of high voltage. Tilt of the barrel is not limited in any way, since all cabling, including

high-voltage lines, comes in through a single junction box in the rear of the barrel. The barrel itself has a three-point suspension. Thumb screws permit easy adjustment, with a positive lock when positioned.

The 80 Kv power supply is compact, light and easy to install. It utilizes a new type of flexible high-voltage cable so that the installation site of the power supply may be as far removed as is necessary. It is assumed that the power supply will be installed in the theater projection room.

Projection Throw, Screen Size

The system includes a high-quality receiver for off-the-air reception. It also accommodates inputs from microwave or coaxial feeds. New circuit designs provide greater reliability and extreme flexibility, while using fewer tubes and other components. All circuits are protected by a "fail-safe" design: failure of one component cannot cause failure or injury to any other component.

With the preferred throw distance of 65 feet, a picture 20 x 15 feet is obtained. However, the system may be operated over a wide range from 32 feet and an 8 x 10 picture on up to 80 feet and a picture approximately 25 x 19 feet.

Merchandising details for the system have not been announced, but National Theatre Supply Co. states that the system will be "competitively priced." Service will be provided by Altec Service Corp. GPL will continue to make available its film-relay theater Tv system which was successfully demonstrated last year.

Filters in Tv Projection

A MARKED improvement in television picture quality from 16-mm motion pictures has been obtained by using optical filters which prevent the red and infrared radiation of the projection beam from falling on the iconoscope mosaic. The bias light is also filtered, which prevents the red and infrared illumination from falling on the back of the mosaic and inner walls of the iconoscope.

The greatest improvement is obtained when a tungsten light source is used, but a marked improvement is noticeable when the filters are used with a carbon arc source.

A series of filters were used for experimental purposes between the condenser system in the projector that removed all the radiation beyond 560, 590, and 620, respectively. It is recommended that for the present a Pittsburgh heat-absorbing glass, No. 2043 (6 mm thick), plus a Corning No. 9780 or 9788 (3 mm thick) be used in the Eastman Model 250 Tv projector.

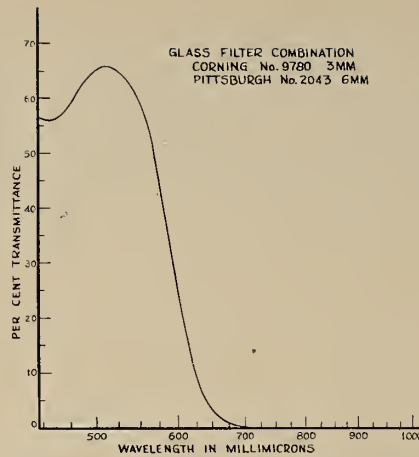

Curve showing transmission vs. wave-length for combination glass filters for Tv projection.

This combination of filters reduces the light on the iconoscope mosaic to the 10% point at 590 millimicrons.

Substantial Improvement Cited

The improvements in reproduced Tv pictures by the use of these filters are as follows:

1. It reduces the over-all haze or veil characteristic of a Tv picture.
2. It prevents difficult shading problems with scene changes.
3. It increases contrast and resolution and gives an increased brightness range or tone scale that can be reproduced.
4. It prevents edge flare.
5. It reduces highlight saturation.
6. It increases video signal. When the filters are inserted, there is a reduction in light on the iconoscope mosaic of approximately 30%. However, there is an increase in video signal of approximately 20%, as indicated by the oscilloscope in the master monitor.

The filter used over the bias light is a 2 by 2 inch by 3 mm Corning No. 9780 or 9788. The use of this filter gives an increased video signal and reduces the projector shutter pulse to a minimum; that is, the signal light transient caused by the short, bright application of light to the iconoscope mosaic.

Commercial Color Usable

The addition of these filters to the projection beam in a Tv projector with adequate light output and to the iconoscope bias light will allow the Tv stations to use commercially available color prints as program material without an undue sacrifice of picture quality, as there has been heretofore.

It also enables the projectionist to

BUY U. S. SAVINGS BONDS

Your Very Best Buy

BUY U. S. SAVINGS BONDS

focus the picture sharply on the mosaic because of the reduction in scattered and reflected light from the face of the iconoscope. It reduces the heat at the motion picture projector gate to a minimum so that a single 16-mm frame may be held stationary in the projector gate and may be projected onto the iconoscope mosaic for thirty minutes without excessive heating and distortion of the film, which would cause the image to go out of focus

Hanover Carbon Burner

The Hanover Continuous Carbon Burner, rated as effecting carbon savings as high as 25%, has been introduced to the trade by Norpat Sales, Inc. Warranted to burn any Suprex-type carbon down to the last inch, this new burner replaces the existing positive carbon jaw with a new type of great accuracy. The automatic action is designed to provide a new pre-heated carbon when the stub has burned down to a predetermined size, with no disruption in or loss of light. The burner has adjustments for warped carbons.

The Hanover does not have to grip the carbon at its end, thus carbon guides may be eliminated to accomplish a fuller distribution of light from the reflector into the aperture. Electrical resistance decreases and arc voltage changes with shortening of carbons due to consumption. Thus the use of the shorter clamping length steadies the arc noticeably.

Precision-built and wholly automatic in operation, with no parts to wear out and thus no maintenance cost, the Hanover burner may be installed quickly and easily by projectionists.

Norpat's merchandising plan includes a guarantee for five years, with free replacement of any part worn due to normal use. Distribution mainly through projectionist agents is planned. Full details are available from "Doc" Faige, at Norpat, at 43 West 45th St., N. Y. C., 19.

Vallen Thrives on Restrictions

Faced with the problem of reducing the quantity of critical materials used in their Aero Speed Curtain Control, Vallen, Inc., of Akron, Ohio, has actually increased the efficiency of the unit by complying with government restrictions.

The new Control is smaller and more compact than the former model, differing completely in basic construction and appearance. There is actually less mechanism, fewer parts to get out of order, and almost no possibility of breakdown. By scaling down the design, Vallen will be able to supply a dependable control of the precisely correct capacity for any installation, thus eliminating the need for over-capacity units.

Safety Switches Important; Don't Neglect Them

ONE urgently needed new habit, indispensable in dealing with Tv equipment, should be formed by projectionists now before such equipment appears in the theatre. A large majority of projectionists appear to have a certain contempt for the dangers inherent in handling live circuits. The practice of disregarding safety switches with which careful manufacturers equip sound apparatus, is widespread. As a matter of fact, some projectionists in their eagerness to handle "hot" circuits, jam these switches, nullifying the manufacturer's precaution.

These projectionists know very well that ordinary lighting voltage has killed many persons; that people have been killed repairing common household radios. But these things do not happen very often, therefore a complete disregard for the 300 to 900 volts that may be found in a sound amplifier has become increasingly common—and a great many men have developed a positive habit of disregarding electrical dangers.

Tv Unit's Exacting Demands

That will be a sad habit to carry over into the days of Tv, when working potentials can be expected to run between 60,000 and 100,000 volts. Of course, such voltages will be surrounded by precautions built into the apparatus by the manufacturers; but the projectionist who today deliberately put out of action the safety switches of their present apparatus probably will carry over that tendency in dealing with the safety gadgets surrounding 100,000 volts. Especially when the show stops suddenly and a man rushes to his apparatus to do something about it quick, old-established habits will tend to carry over.

The time to form new habits is now.

Every projectionist knows that he should open switches and bleed condensers before working on electrical circuits. He also knows that he should form the habit of doing that *always*—even with circuits that are not very dangerous and even when his show has stopped. Every projectionist group should foster the development of correct habits in handling electrical circuits among its own members. The formulation of such a good habit will stand the craft in good stead now and in the future.

Altec's Role in Theatre Tv is Spelled Out by Bessey

Altec Service Corp. intends to play a very important role in the development of theater Tv, according to an announcement by Harry M. Bessey, executive vice-



more
B.A.*

*(BOXOFFICE
APPEAL)

MOVIES
ARE
BETTER
THAN
EVER

with **SUPER SNAPLITE**

f/1.9 projection lenses

● GREATER LIGHT ● GREATER CONTRAST ● GREATER SHARPNESS

Watch your "B. A." climb when you install Super Snaplite Lenses. Give your patrons the benefit of pictures at their best. You can't beat the Super Snaplite f/1.9 when it comes to putting a clear, sharp picture on your screen.

Super Snaplites give you a true speed of f/1.9 in every focal length up to 7 inches. Ask for Bulletins 207 and 209.

"You Get More Light with Super Snaplite"

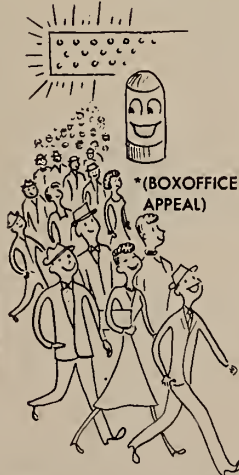

KOLLMORGEN

2 Franklin Avenue
Brooklyn 11, New York

Optical



CORPORATION

president. Emphasizing the fact that Altec is the only independent service company operating on a national basis, and with a backlog of diversified experience in all branches of the electronic art, Bessey said that the combination of manufacturing, development and laboratory facilities with a trained national service group adds up to a technical know-how that could never be matched on a local basis.

Altec has already reached an agreement with National Theatre Supply Co. to supervise and service installations of the GPL Simplex Tv system. Negotia-

tions with other manufacturers are now in progress.

Close cooperation with projectionists, said Bessey, is a major aspect of the Altec program.

Westrex-Reeves Magnetic Film Deal

Westrex Corp. and Reeves Soundcraft Corp. have completed negotiations under which Westrex will distribute on a world-wide basis the complete line of Reeves professional magnetic recording films. This includes not only the standard 35-, No. 17½-, and 16-mm full-width magnetic-coated film used in original re-

ording, but a new product "Magna-Stripe" a narrow strip of magnetic material coated on clear motion picture film base intended for use in the editorial departments in the professional motion picture field.

These films, available at 100 Westrex offices throughout the world, offer numerous distinct technical features, one of which is footage edge-numbering of the film.

Joe Hornstein, Pioneer Supply Dealer

Joe Hornstein, pioneer projectionist and theater equipment supply dealer, died on June 19 of a heart attack suffered at his New York City home. He was 65 years of age. Starting as a projectionist in 1903, Hornstein soon entered the supply field. First as general manager of the old Howell Cine Equipment Co., then with National Theatre Supply, and later as head of Continental Theatres Accessories (Warner Bros. subsidiary), Hornstein became one of the best known equipment men in America.

In 1934 the firm of Joe Hornstein, Inc., was formed, and it now has three branches—New York, St. Louis, and Miami. Hornstein was a member and former treasurer of IA Local 306, N. Y. City, and a member of the Odd Fellows, Masons and Motion Picture Pioneers. He is survived by his wife, three sons, and a sister.

TECHNICAL GAINS IN 1950

(Continued from page 22)

arc projection lamps have been described. These units feature fast optics, arc-positioning devices, forced air control of exhaust gases and new methods of automatic arc control.

In the field of control of heat in the projection optical train, there have been a number of installations of units with heat-absorbing glass filters and others with compressed air blowing against the film. In addition, considerable work is being done experimentally and in field tests with treated mirrors and optical train filters of the interference type.

A new all-plastic screen made of Firestone "Velon" plastic and known as RCA Snowwhite Evenlite vinyl screen made its bow. The material is 0.012 in. thick, weighs 1/9 psi and is said to be sag-proof. It is pigmented with titanium dioxide and surface embossed for high efficiency and diffusion. It is also flame-proof, mildew proof and unaffected by heat, cold or moisture. The surface is rugged and can be cleaned by washing, soft brush or vacuum cleaner.

A new Walker high-intensity screen is made of plastic in which no vinyl is used. The metallized surface is made up of elliptical forms which spread the light fanwise to control reflection. It is recommended for theaters with wide-angle viewing conditions, but with no more than a 12-deg. projection angle. It is claimed that the control of stray

THIS ONE WORKS . . . burns carbons down to the last inch

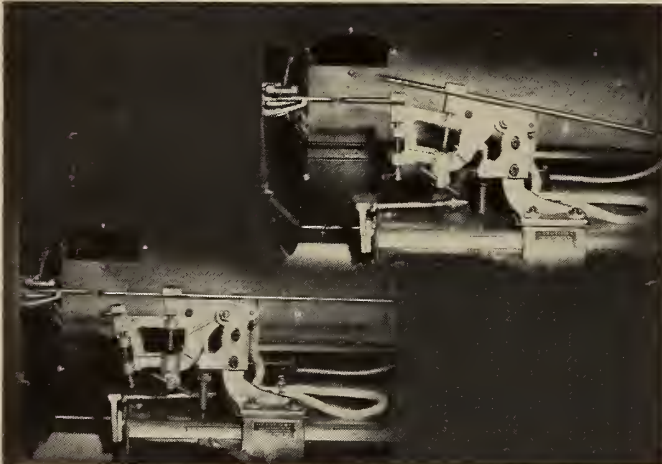

A—Stub in burning position.

B—Stub burned down to the last inch—new carbon finishing reel.

Both Peerless Mag-narc Mounting.

Below: Strong Mogul Mounting.

HANOVER Continuous CARBON BURNER

- Any operator can install it . . . quickly, easily in a Suprex type lamp.
- Parts don't wear out—no maintenance cost.
- Precision built, completely automatic.
- Pre-heats incoming carbon.
- No disruption or loss of light in changeover.
- Eliminates uncertainty of burning period of any size carbon stub.
- Pays for itself immediately by using accumulated waste!

Priced Higher
Actually it costs less because the initial cost is the only cost . . . there are no extras to buy nor are periodic changes of the jaw necessary.

Actually Costs Less
7750 How to order: send name, address and type of arc lamp—we ship correct unit C. O. D.

SOME AREAS STILL OPEN FOR SALES-MINDED PROJECTIONISTS—WRITE TO "DOC" FAIGE AT:

NORPATSALES, INC. 47 W. 45th ST., N.Y. 19 - CABLES: NORPACREST, NEW YORK

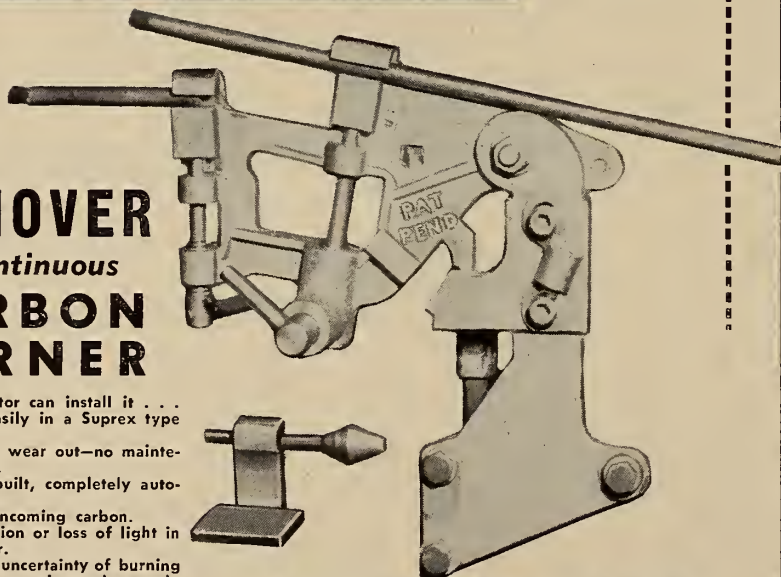

MINUTES MEAN MONEY

Carbons which still have from 2 to 15 minutes "burning life" but are too short to take a chance with, now can be used right down to the last inch . . . without loss of light . . . without risk!

5 YEAR PRODUCT GUARANTEE

against inferior materials and workmanship and against normal wear and tear.

MONEY-BACK GUARANTEE

You have 5 days from the time you receive the unit to install and test it thoroughly. It costs you nothing to prove it!

OTHERS BEFORE YOU HAVE PROVED IT

One theatre burned stubs for 2 days . . . proof of "true" economy! Ellis Theatres of Philadelphia tried one and ordered 25 . . . "true" economy proved!

light improves contrasts and results in better apparent definition.

Cinerama, a system of exhibiting three frames of film in a curved panorama, has been demonstrated. It is stated that, while the inventor does not claim stereoscopic results from a strictly technical standpoint, the effect is one of super reality. The system includes the use of several sound tracks for projection of stereophonic sound.

16-mm Film, Sound Reproduction

1950 has been a year of marked improvement in the whole 16-mm process, inspired mainly by Tv. A number of professional-type 16-mm projectors have been made available, with performance approaching 35-mm standards.

Eastman announced and demonstrated a heavy-duty 16-mm professional projector which uses the same type of intermittent sprocket movement as in 35-mm professional projectors.

International Projector Corp. has described a sturdy, high-quality 16-mm projector designed to meet U.S. Navy Bureau of Ships Specification CS-P-41A.

Mitchell Camera Corp. announced a new "giant" 16-mm professional projector which offers optional high-intensity carbon arc or incandescent lamp illumination. It was designed to function with standard 35-mm sound equipment.

Big Navy 16-mm Program

Approximately 1,400 16-mm sound motion picture projectors, built to comply with the high performance required by the Joint Army-Navy Specification JAN-P-49, were put into service by the armed forces during the past year. The Navy is employing these projectors to evaluate and accept all 16-mm prints procured by the Navy.

The prints are screened with both lead sulfide- and caesium-type photoelectric cells to insure that there will be no material difference in sound reproduction when the prints are presented to the Fleet on either type of equipment.

Television 'Comes of Age'

Many people have said that Tv came of age in 1950. There is considerable truth in this statement and it may be traced largely to the fact that the industrial companies of America have recognized Tv's tremendous sales appeal and have consequently devoted large sums of money to the production of shows intended for release in many cities throughout the nation.

It has been possible to cover many of these cities, and consequently a large percentage of the Tv audience, with live programming via the facilities of A.T.&T. The so-called nonconnected cities are still covered by the use of video recordings, the quality of which has improved

Still The One in '51

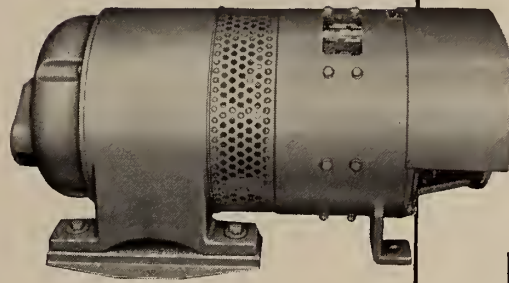

TYPE "HS" TRANSVERTER

After
50 Years
Of
Leadership

The Hertner TransVerteR

REG. U. S. PAT. OFF.

*For Unexcelled
Performance in*

**DELUXE THEATRES
SMALLER THEATRES
DRIVE-IN THEATRES
AUDITORIUMS**

**IMMEDIATE DELIVERY OF
ALL STANDARD SIZES**

6 TYPES

Hertner Transverters are made in six types, for theatres of all sizes:

TYPE "LV" for Simplex HIGH 1 KW Arcs

TYPE "HI" for Suprex Type Arcs

TYPE "HIH" for Suprex and Spot Arcs

TYPE "HS" for 50-63 Volt High Intensity and Spot Arcs (for Notional Excellite 55,000 type lamp)

TYPE "MA" for 50-70 Volt Low and High Intensity Arcs

TYPE "CP" for 60-75 Volt High Intensity Arcs

PLUS FEATURES

- Velvet-smooth power—no AC ripple
- Cool, quiet performance
- Safe, slow operating speed
- Economical, long-life, trouble-free operation
- Modernized, compact, horizontal design
- Proved experience since 1901
- Sealed-for-life ball bearings
- Designed for specific power supply of each installation
- Easily adjusted ballast rheostats

Distributed by

NATIONAL THEATRE SUPPLY

In Canada: GENERAL THEATRE SUPPLY COMPANY



THE HERTNER ELECTRIC COMPANY

12690 ELMWOOD AVE. CLEVELAND 11, OHIO

A General Precision Equipment Corporation Subsidiary

MOTORS • MOTOR GENERATORS • GENERATOR SETS

greatly during the period covered here.

The availability of higher budgets has allowed the Tv networks and studios to use more care in production techniques and staging. Notable improvements have resulted, for example, in lighting, costuming and make-up, the use of process screens, and in a general recognition of how the limitations of the system must always be carefully considered in the staging of a studio production.

The marked change in Tv has required a great expansion of many Tv stations and studios throughout the country. There seems to be a trend toward more and more space, and the industry has concluded that facilities at least approaching in size those of the motion picture production lot will ultimately be required. There have been several purchases of large acreages on which numerous buildings will operate in order to handle the production requirements which are foreseen.

Extensive Use of Film

Direct photography for Tv shows has increased during the year. A number of production companies have operated specifically for this purpose and with considerable success. Most such productions have been of half-hour shows, some of

which have been serialized. Both 16-mm and 35-mm cameras have been employed, although the trend at the moment seems to be the favor of the latter, in spite of the fact that many Tv stations are forced later to use 16-mm reduction prints.

Of the top Tv network shows on the air at the close of 1950, approximately 20% were on film. There has been some interest in the technique of so-called simultaneous filming of live Tv shows; however, this technique still is not widely used.

The demand for special prints reflects the growing practice in the Tv industry. Most large stations on Tv networks have established standards for print characteristics which give optimum Tv quality. Background projection as an adjunct to live programming is becoming more common.

Tv Film Projection

The technique of film projection for Tv transmission has received a lot of study. A method of improving the image quality by using filters in the projector to remove infrared radiation, and by filtering edge- and bias-light in iconoscope film cameras has been proposed. As a result of the interfering effects of light level and tube variation, this pro-

cedure is still controversial.

Eastman has manufactured a new 16-mm Tv projector, model 250, which is intended to give superior performance for film chains. The projector operates on the conventional 5% application principle, but offers improved picture steadiness, brightness and definition as well as excellent sound quality. Facilities are provided for continuous projection of a single frame, or regular projection with remote operation.

Video Recording Problems

Video recording progress during 1950 has been very great. In fact, it is generally agreed that within the limits of the Tv system as established by the FCC and as further laid down by equipment limitations, the recording system can take down what is delivered to it. Phrased another way, it is conceded now that the operation inside the studio is the point where the recording is made or broken.

Unfortunately, many Tv shows are rehearsed so little that certain fundamental rules that affect the quality of a recording are violated. Whenever this is done the results are extremely unfortunate.

To be more specific, it is necessary that lighting be handled with extreme

Old Type Lens

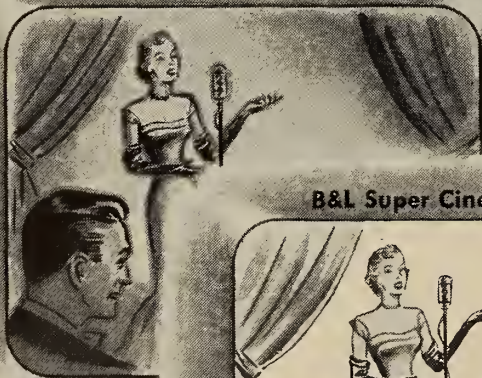

B&L Super Cinephor Lenses

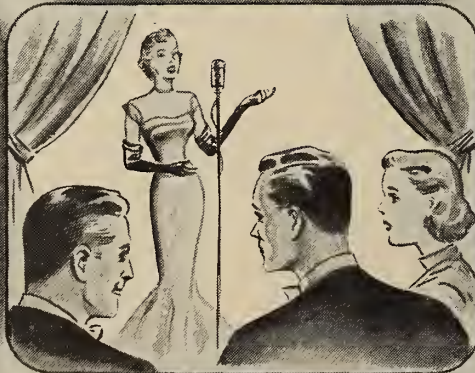

44% to 100% Brighter

YOUR THEATRE is as modern

as the IMAGE on YOUR SCREEN

Protect your investment . . . Build Profits . . .
with B&L Super Cinephor Lenses

Don't lose patrons by projecting dim, eye-straining images. B&L lenses bring your audiences today's finest image quality . . . brighter, sharper pictures with *edge-to-edge* brilliance and contrast. Build *steady* patronage, *steady* profits, with B&L lenses.

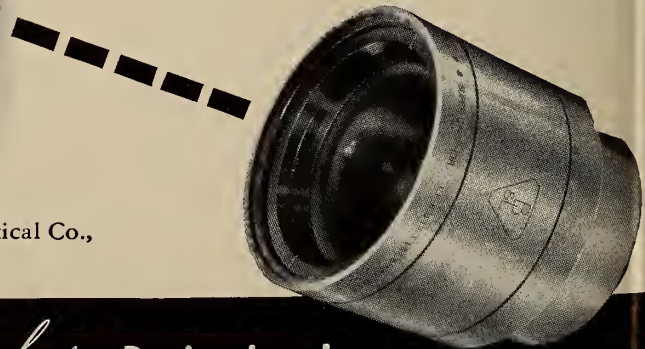

Write for complete information to Bausch & Lomb Optical Co.,
616-7 St. Paul Street, Rochester 2, N. Y.



Bausch & Lomb

Super Cinephor Projection Lenses

care. A lighting contrast of no more than 3 or 4 to 1 should be maintained at all times. In addition, since generally more than one camera is used in a TV studio, the camera angles must be carefully observed so that lighting will be adequate regardless of which camera is in operation.

Furthermore, camera levels must be controlled in order to maintain a balance between cuts. It is much more important that this balance be observed with TV recording than when producing a show which will be released only as a live show.

Much New Tv-Film Equipment

The sound portion of TV recordings has been handled in numerous ways by the various studios throughout the country. Some of the best sound has been obtained through the use of tape recording which is synchronized electrically or by the use of perforated tape. Both single and double system recordings are still employed.

A new complete chain of equipment for either TV recording or large-screen TV projection by an intermediate film system has been developed by General Precision Labs. This equipment consists of a high-quality monitor, 16-mm recording camera rapid film processor and projector. The monitor is provided with electronic blanking for the frame-rate conversion and gradient correction circuits. The camera has the rapid pull-down required of all TV recording cameras and a high-quality sound-recording head. The rapid film processor can be used directly with the camera or separately.

Navy's Tv Educational Program

During 1950 the Navy continued studies of TV as a method of mass training. The psychological studies to measure the relative effectiveness of TV training showed conclusively a definite superiority over direct classroom instruction. In the spring of 1950 the Signal Corps collaborated to present eight weeks of one-hour programs over a ten-city CBS network to reach approximately 5000 reserves.

In continuing its investigations of new TV equipment for Navy use, work was advanced toward the final design of a prefabricated classroom which could be mass produced in time of emergency.

The Navy experiments have attracted wide attention and have helped focus the interest of educators on TV training. The recent FCC hearings on allocations for educational television stations is concrete evidence of this aroused interest.

The first acceptable motion picture photography of color TV kinescope images was performed by the Navy, combining techniques developed for recording of radar PPI scopes and TV kine-

scopes. A modified professional 16-mm camera and a specially designed high-speed, 25-mm, F:0.7 lens were employed.

Tv Remote Presentations

The tremendous impact of TV as a means of taking the home audience to the scene of a remote, whether it be a sporting event or another type of special feature, has been demonstrated time and again during 1950. In fact, the effect of TV on the local audience at a sporting event has created a national controversy. The "gate" at football and baseball

games has been increased, decreased and unchanged—depending entirely upon whom you talk to and in what part of the country your conversation takes place. However, that the public enjoys the telecasts of such events is without controversy.

Theater Tv Developments

In the early months of 1950, RCA completed the design of its first commercial theater TV equipment, the Model PT-100. This is a direct-projection system employing a projection kinescope

It takes a **SPECIALIST** to Protect the **HEART** of Theatre TV

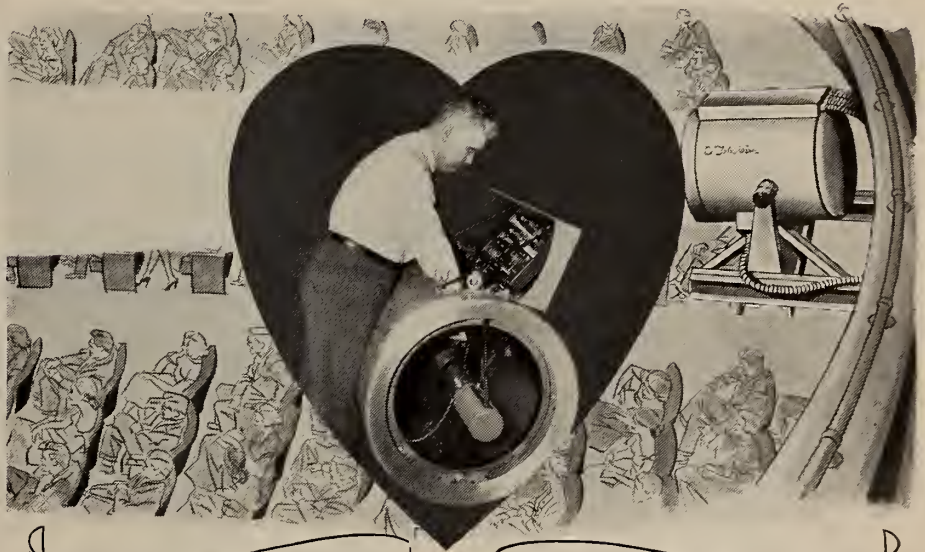

PROJECTION...SOUND

...AND RCA SERVICE

Theatre TV's complex circuits require **TRAINED** and **EXPERIENCED** service specialists—capable of using specialized test equipment. This is not a job for the inexperienced.

Finest Theatre TV Service Anywhere. RCA Service field technicians are theatre TV experts with specialized training in the television laboratories and factories of RCA—*pioneer in theatre TV.* They are

It costs so little to protect so much

Nowhere else do you get such *specialized* theatre TV service at a price so low. Write for complete information.



technically qualified to supervise the installation of complete theatre TV systems. They know how to properly maintain the equipment for maximum performance. The RCA Service Company has installed and serviced more theatre TV systems than any other service organization—anywhere. There is no substitute for the RCA Service Company's specialized experience in Theatre TV.

Scheduled Service and Parts Plan. Like the Service Plan for sound motion picture theatre equipment, RCA's Theatre TV Service includes regular scheduled point-to-point checkup and maintenance as well as emergency service. Tubes and components are replaced without additional charge when Parts Plan is included.



RCA SERVICE COMPANY, INC.

**A RADIO CORPORATION of AMERICA SUBSIDIARY
CAMDEN, NEW JERSEY**

and Schmidt optics. A pilot run was placed in production and twelve equipments were delivered and installed in theaters in Providence, Albany, Binghamton, Brooklyn, the Bronx, Queens Village, Chicago and Los Angeles in time for the start of the fall football season.

At the TESMA Convention in Chicago in October, General Precision Labs. announced and demonstrated an intermediate film theater-TV equipment using 16-mm film.

United Paramount Theaters, Inc., installed Paramount's intermediate film equipment in one of its Detroit theaters just prior to the start of the football season.

The Eastern theaters have all shown a series of football games carried by the Tv broadcasting networks. In spite of the fact that the theaters were attempting to sell entertainment that was available free on home Tv, the over-all box-office results were highly favorable and

improved as the season advanced.

Several theaters are using Tv news programs on a daily basis to replace a regular film newsreel. This has been very popular because of the timeliness of the news.

Exclusive Tv Program Rights

United Paramount Theaters obtained the exclusive television rights to the Univ. of Illinois and Univ. of Michigan football games and showed them in theaters in Chicago and Detroit. Attendance at these first exclusive showings was very satisfactory, with sellouts toward the end of the season.

A group of Eastern theaters is working on exclusive programming which they hope to get under way before the year is out.*

Twentieth Century-Fox secured the exclusive use of the Swiss Eidophor system for theater Tv. This system provides excellent image clarity and screen brightness and uses a high-intensity carbon arc as a light source.

* This program has already been effectuated; and recent estimates place the number of theater Tv installations at 100 by the end of this year.

U. S. Army Contract to Genarco

Genarco, Inc., of Long Island City, N. Y., makers of the Metro-Lite high-intensity carbon arc spotlight which is used extensively in the theater and auditorium fields, has been awarded a substantial contract by the U. S. Army for the development of a powerful searchlight which will outmode any spotlight made during World War II.

While the full Genarco facilities will be concentrated on the needs of the Army, its production facilities are still flexible enough to supply the needs of the entertainment field with spotlights and replacement parts for both old and new units.

CARBON ARC SCREEN LIGHT

(Continued from page 11)

while the larger-cored 16-mm carbon at 460 amp gives only 150 lm/amp.

This relationship is shown more directly by Fig. 5 which utilizes the data shown on Fig. 4, together with similar data calculated for the other optical speeds indicated. Here lumens-per-ampere are plotted against carbon diameter for each of four different optical speeds. Each curve is represented as a band, including the extremes in current efficiency encountered with each carbon size. Here again, the higher current efficiency of the small-diameter carbon is confirmed for each of the optical speeds investigated.

The data so far have been concerned only with current efficiency, and if this

NATIONAL HAS EVERYTHING
FOR THE PROJECTION ROOM

Get it
from
National!

NATIONAL

THEATRE SUPPLY

Division of National • Simplex • Bludworth, Inc.

29 BRANCHES • COAST TO COAST

NEVER HAS

Economy

BEEN SO

ESSENTIAL AS NOW!

THERE IS A LORRAINE CARBON TAILORED FOR
YOUR SPECIFIC PROJECTION REQUIREMENT

Send necessary projection equipment
data to guide us in recommending the
Lorraine Carbons that will do your
theatre or drive-in projection job better
and More Economically.

SLOW BURNING

SAVINGS IN POWER CONSUMPTION

SAVINGS IN MAINTENANCE

ECONOMIZE

WITH *Lorraine*
Carbons

Lorraine CARBONS, INC., BOONTON, N. J.

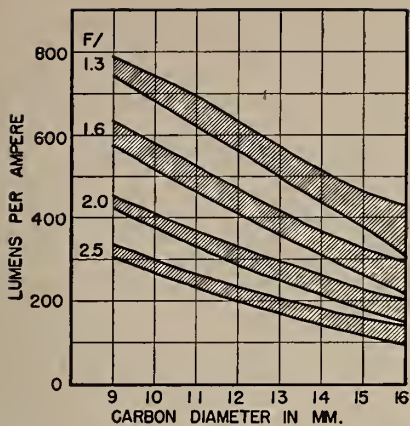

FIG. 5. Current efficiency in screen-light production.

were the only criterion, the smallest possible carbon would always be chosen for a given job. However, no consideration has yet been given to the screen-light distribution ratio, the burning rate of the carbon, or the color uniformity of the screen, all important factors in making a choice in any particular situation.

Size vs. Light Uniformity

Figure 6 shows the variation in screen-light distribution ratio with carbon size, at the same optical speeds previously considered. Here the decided improvement in screen-light uniformity with increasing size is effectively demonstrated, particularly as the optical speed increases to give a steeper slope to the curve. The data shown in Fig. 6 represent the average for all the carbons tested, individual values showing some scattering around these curves, but not sufficient to invalidate the general trend.

It should be pointed out, however, that, contrary to the general indication of Fig. 6, all 9-mm carbons, for instance, do not yield a lower screen-light distribution than all of 10-mm size. In fact, the reverse is sometimes the case in practical service comparisons. Different ratios of

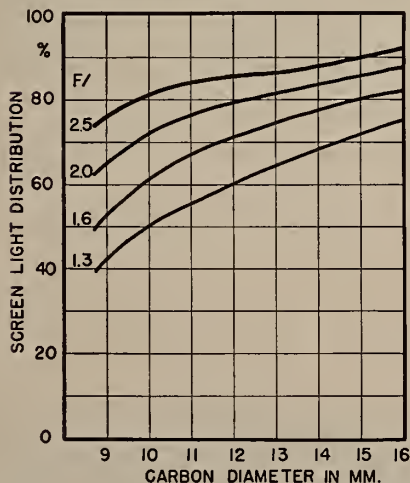

FIG. 6. Screen-light uniformity; side-to-center brightness ratio.

core-to-shell diameter, different methods of construction and burning, all contribute to the scattering previously described.

Two additional factors contribute to the screen distribution value actually achieved in a given commercial situation.

Two Additional Factors

The first is due to the slight departure in shape of all commercial lamp mirrors from the perfect ellipse assumed in the present calculations. Instead of all the

crater images from all angles of view being precisely centered in the aperture, they are displaced in practice, by normal errors in mirror shape, to spread the light in less peaked fashion, but with negligible loss in total lumens on account of this spreading.

In the second place, the projectionist, in adjusting his optics to give the best-looking screen, may decide upon a slightly out-of-focus setting, and sacrifice somewhat on screen light in favor of a flatter screen.

The distribution values of Fig. 6, there-

ANSWER TO YOUR TECHNICAL PROBLEMS...



*The Altec
Service Man and
the organization
behind him*

*The
Altec
Service
Man*



161 Sixth Avenue,
New York 13, N. Y.

PROTECTING THE THEATRE—FIRST PLACE IN ENTERTAINMENT

"World's Most Powerful Spotlight"

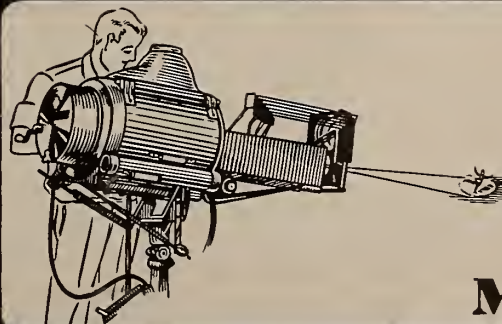

The METRO-LITE high-intensity carbon arc spotlight comes in two models:—

- ★ MODEL ME 4 125 Amps D.C.
100 ft. to 400 ft. throw.
- ★ MODEL ME 5 "Vaudeville"
60 to 85 Amps D.C.
75 ft. to 250 ft. throw.

METRO-LITE

Literature available on both units upon request to

GENARCO, Inc. 36-56 b 34th St., Long Island City 6, N. Y.



Stop BEING A CARBON WASTER

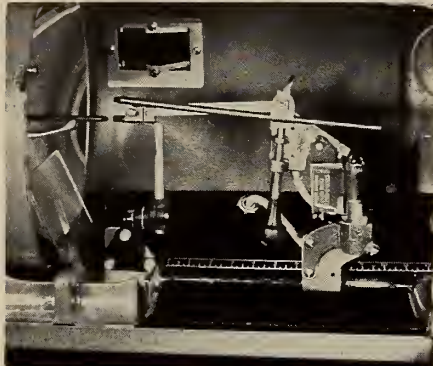

The practice of throwing away carbon stubs can cost you thousands of dollars.

THE CRON-O-MATIC Fully Automatic CARBON SAVER CUTS CARBON COSTS 25%

Uses stubs of all lengths without any preparation. It's no longer necessary to guess whether or not a carbon stub will burn a full reel. Simply insert in the holder. When it is entirely consumed, the new carbon goes into use without losing the light. The Cron-O-Matic in no way interferes with the regular operation of the lamp.

Start saving big money now.

Adaptable to Ashcraft "D", Brenkert-Enarc, Peerless Magnarc and Strong Mogul lamps. Only \$52.50. Quickly pays for itself . . . then goes on to make money for you.

SOLD BY

- | | |
|---|---|
| ALBANY, N. Y.
National Theatre Sup. | DENVER, COLO.
National Theatre Sup. |
| ATLANTA, GA.
Southeastern Theatre
Equipment Co. | JACKSONVILLE, FLA.
Southeastern Theatre
Equipment Co. |
| BOSTON, MASS.
Joe Cifre, Inc. | KANSAS CITY, MO.
Shreve Theatre Supply |
| BUFFALO, N. Y.
Eastern Theatre Supply
Co., Inc. | MEMPHIS, TENN.
Stebbins Theatre
Equipment |
| CHARLESTON, W. VA.
Charleston Theatre
Supply | MEMPHIS, TENN.
Monarch Theatre Sup-
ply Co., Inc. |
| CHARLOTTE, N. C.
Southeastern Theatre
Equipment Co. | NEW ORLEANS, LA.
National Theatre Sup. |
| CINCINNATI, OHIO
Midwest Theatre Sup-
ply Co. | NEW ORLEANS, LA.
Southeastern Theatre
Equipment Co. |
| DALLAS, TEX.
Hardin Theatre Supply
Co. | PITTSBURGH, PA.
Atlas Theatre Supply
Co. |
| Southwestern Theatre
Equipment Co. | SALT LAKE CITY, UTAH
Service Theatre Supply
Co. |
| | SAN FRANCISCO, CAL.
Western Theatre Sup. |
- If your theatre equipment dealer cannot supply you, order direct.

PAYNE PRODUCTS COMPANY Cron-O-Matic Division 2454 W. Stadium Blvd., Ann Arbor, Mich.

- () Please send free literature on Cron-O-Matic Carbon Saver.
() Please ship Cron-O-Matic Carbon Saver, C.O.D., including postage.
() Remittance herewith.

NAME
THEATRE
STREET
CITY & STATE

Dealer Inquiries Invited
Export: Frazer & Hansen, Ltd.
San Francisco, New York, Los Angeles

fore, are not necessarily the same as those which would be obtained in a practical projector assembly, although the basic trends between sizes and optical speeds are as indicated.

Carbon Consumption Rate

Let us consider next the consumption rate of the carbon. This depends so much on carbon design, on the method of burning, whether the carbon is plated or unplated, whether it is burned with or without current jaws, and with or without water-cooling, that no simple relationship exists. However, in situations where equivalent screen light is given by carbons of different sizes, the smaller carbon will always burn the faster. The exact magnitude and economic significance of this difference requires determination in each specific case, and is always an important factor to be considered.

Blowing of the arc according to principles recently defined by Dr. Edgar Gretener,² is also a major factor in the determination of current and carbon efficiency. Apparently the light secured at a given current is very substantially increased by this blowing, while the carbon consumption per unit of light output is less markedly affected.

Screen Light Color Value

With respect to screen color, it is most difficult to express color differences in terms of numbers of true comparative significance, and no attempt has been made to do this with the various trends reported here. However, the larger carbon gives a more complete filling of the aperture from all angles of view, and also tends to give a more uniform screen color in any comparison of different sizes at equivalent light levels. Further, with the larger-sized carbon, screen light and color uniformity is better maintained over a wider range of maladjustment of the positive-carbon position.

It was previously indicated that the smaller carbon requires a higher collection angle for maximum screen light than does the larger carbon. This general relationship is indicated for four different optical speeds by the curves of Fig. 7. The increasing slope at the higher speed shows that this effect of carbon size becomes more pronounced as the speed increases.

Speed of Optical System

Finally, the relationships plotted in Fig. 8 show that increases in optical speed into the aperture do not result in as great increases in illumination as the relative optical speeds alone would pre-

² "Physical Principles, Design and Performance of the Ventarc High-Intensity Projection Lamps," by Edgar Gretener; J. Soc. Mot. Pict. & Tv Eng., Oct., 1950.

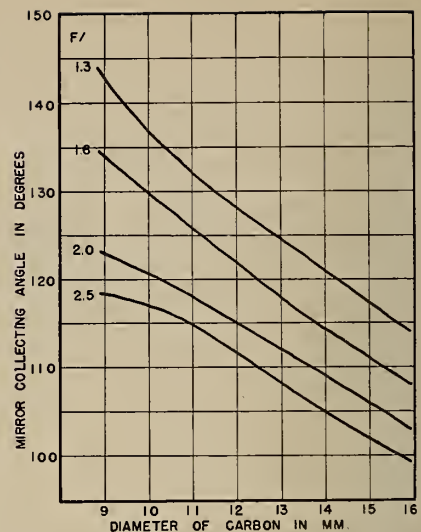
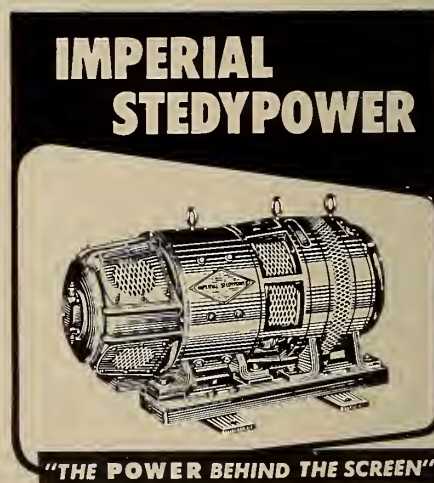

FIG. 7. Collecting angle giving maximum screen light.

dict. Compared to the illumination obtained with an F:2.5 system, an increase to F:2.0 should theoretically give 6.25/4.00 or 1.56 times as much illumination. The ratio calculated with 16-mm carbons is 1.48, and for 9-mm carbons, 1.40—95% and 90%, respectively, of the theoretical amount.

As might be expected, this departure from the theoretical is greatest for the



IMPERIAL STEDYPOWER

"THE POWER BEHIND THE SCREEN"

SPECIAL MOTOR GENERATORS FOR EVERY ARC PROJECTION

- Proven "Trouble Free" Performance
- Quality Built, Quiet Operation
- "Rubber in Shear" Mounted Vibration Free
- Long Life, Low Maintenance

Distributed by Independent Theatre Supply Dealers or Write to:



smallest carbon, the reason being that the crater images on the aperture are not sufficiently large to fill the aperture completely at all angles of view, and that the brightness distribution across the crater is most peaked for the smaller carbons.

This paper thus defines certain basic relationships which should be recognized in the most effective development of the

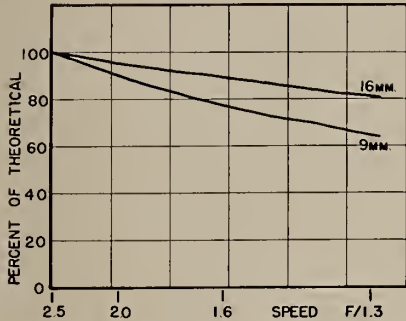

FIG. 8. Actual versus theoretical gain in screen light with increasing optical speed.

combined arc carbon and optical system to do a given job.

Broadly speaking, a small carbon can be utilized to give highest current efficiency; this requires the use of a high collection angle, gives a less uniform screen-light distribution and screen color, and is more sensitive to light and color variations as the carbon is moved from the exact focal position. The larger carbons operate with lower current efficiency but give a higher quality performance in all other respects, at a higher cost.

The choice in a particular situation should be based upon a balance of these various factors as applied to the specific economic considerations involved. As in other fields, there are proper applications for many possible combinations of cost and quality.

THE MAGIC OF COLOR

(Continued from page 9)

indistinguishable from the blank side of the film. This was especially true of silent Technicolor films, for these carried no soundtrack or frame lines in silver.

Like the older double-film Technicolor, the old-style imbibition-process color films depended on two colors, and hence could not cope with yellow, purple, and certain other colors. Also, blue sky had a distinctly greenish tint. Only red, green, and brown with their several shades and tints appeared at all natural on the screen. The next step in the development of the Technicolor process was to adapt it to the well-known principles of tricolor photography.

Early Tricolor Processes

Tricolor photography is much older than Technicolor—older, even, than the movies. Several pioneers in the art of photography had successfully made tricolor separation negatives as long ago as the 1860's. Some of these sets of three negatives each were made by successive exposures in ordinary "still" cameras through vermilion, emeraude, and indigo filters. Other experimenters had actually constructed workable "one-shot," or beam-splitting, cameras in which the three negatives could be exposed simultaneously.

Only the lack of panchromatic photographic emulsions hampered these early experiments in color pictures. It took an enormously long exposure to get an impression on the plate exposed through the vermilion filter.

Vermilion (orange-red), emeraude (yellow-green), and indigo (violet-blue) are the three primary colors. It is to

EFFICIENT • DEPENDABLE

RECTIFIERS

for Every Type Projection Lamp



**2-Tube
4-Tube
6-Tube**
Single and Three Phase Models for

- Rotating Feed Angular Trim High Intensity
- Copper Coated Coaxial High Intensity
- 1 K.W. High Intensity
- Low Intensity

Smooth Output Current • Long Life
Low Operating Temperature
Flexibility in Control

Write today for literature or free demonstration.

THE STRONG ELECTRIC CORP.

31 CITY PARK AVENUE
TOLEDO 2, OHIO

PROJECTION LAMPS • RECTIFIERS
SPOTLIGHTS • REFLECTORS



• The NEW, improved, positive method of permanently patching all types and makes of film—8mm., 16mm., 35mm., Tru-Kolor, Technicolor, Kodachrome, Nitrate and Safety Film.



Used and endorsed by Projectionists in countless theaters.

specifically for lasting Patches.

ESSANNAY ELECTRIC MANUFACTURING CO.
Chicago 10, Illinois 1438 North Clark Street

ONLY

Century PROJECTORS

HAVE EVERYTHING



4-inch diam. lens mount

Water-cooled apertures

Oil-less Bearings

CENTURY'S high-efficiency projector with the NEW 4-inch diam. lens provides pictures of increased brightness and appeal—for even the largest drive-in screens.

CENTURY'S water-cooled aperture gives as much light with a 90 ampere arc as other projectors using a 180 ampere arc and heat filters!—Reduce power cost—Get sharper pictures—Save film.

CENTURY'S sealed, oil-less bearings and glass-hard gears reduce maintenance costs. No oil sprays or baths to mess up film or projection room.

You can SEE and HEAR the difference!

CENTURY PROJECTION AND SOUND SYSTEMS
See your dealer or write for information

CENTURY PROJECTOR CORPORATION

New York, N. Y.

**CLAYTON BALL-BEARING
EVEN TENSION TAKE-UPS**

For all projectors and sound equipments

All take-ups wind film on 2, 4 and 5 inch hub reels.
Silent Chain Drives

THE CLAYTON REWINDER

For perfect rewinding on 2000-foot reels.

CLAYTON PRODUCTS CO.

31-45 Tibbett Avenue

New York 63, N. Y.

these colors, and to no others, that the color-receptive centers of the eye are tuned. "In-between" colors are synthesized by the eye from various proportions of the three primaries. Any method of color photography which utilizes all three primaries is therefore capable of reproducing every color which human vision can appreciate.

The old-time photographers who had devised one-shot color cameras reproduced their pictures by additive projection. The cameras, themselves, were used as projectors. The negatives were printed on lantern-slide plates and placed in the projector (camera) which was fitted out with three separate light sources. Each positive plate was placed behind the same color filter used for photographing the negative from which it was printed. Thus one plate was projected with vermilion light, the second with emeraude, and the third with indigo light.

Thomascolor, Rouxcolor Processes

Superposition of the three primaries, in varying proportions, resulted in a recreation on the screen of the original scene in full natural color. The results were said to be very good. This process has no limitations as far as color rendition is concerned.

Thomascolor and Rouxcolor are attempts to adapt the simultaneous additive

tricolor process to motion-picture projection. Four frames, two side by side, occupy the space of a single frame of standard 35-mm film. Three of the diminutive frames carry the color record in black-and-white; the fourth frame, unneeded, is totally black. A special lens containing aligning elements and V, E, and I filters must be used in order to provide color filtering and to superimpose the colored images on the screen.

This additive process is not satisfactory. From the projectionist's point of view, too much light is wasted. (About 80% is lost.) And registration of the superposed frames is not easily attained in the desired degree of perfection. Moreover, the tiny Rouxcolor frames are very "grainy," and slight defects in the operation of the projector intermittent are highly magnified on the screen.

Thomascolor, alias Rouxcolor, may

therefore be dismissed as of no practical importance as far as theatrical motion pictures are concerned.

The Keller-Dorian Method

Another additive tricolor process of academic interest was the Keller-Dorian method known as Kodacolor. This was extensively used for 16-mm "home movies" before the introduction of Kodachrome, an entirely different method.

The blank side of Kodacolor raw stock was "lenticulated," or embossed, with tiny cylindrical lenses running lengthwise—about 559 of them to the inch. The film is threaded up in the camera with the lenticulated side facing the lens, over which a special filter comprising three vertical color strips (vermilion, emeraude, and indigo) is placed. The function of the color filter and film-lenticulations is to cause the image to be impressed upon the emulsion of the film as three distinct images. Each of these images corresponds to one of the filter areas, and only one.

Kodacolor film, upon development and reversal into a positive for projection, looked to the eye like an ordinary black-and-white film. To use the film, it was necessary to place an exact replica of the camera color filter over the lens of the projector. The process was then reversed; and the original scene appeared upon the movie screen in full natural color. The chief drawbacks to Kodacolor were loss of light by absorption and fuzzy picture definition on the screen.

[TO BE CONTINUED]



How Many?

Was this copy dog-eared when it came to you? How many men read it ahead of you?

You would receive a clean, fresh copy if you had a personal subscription—and you wouldn't have to wait—you would be first to read it.

Use coupon below.

INTERNATIONAL PROJECTIONIST,

19 West 44 St., New York 18, N. Y.

Enter my subscription for 1 year—12 issues—\$2.50
 2 years—24 issues—\$4.00

Foreign and Canada: Add 50c per year.

Name

Address

City State

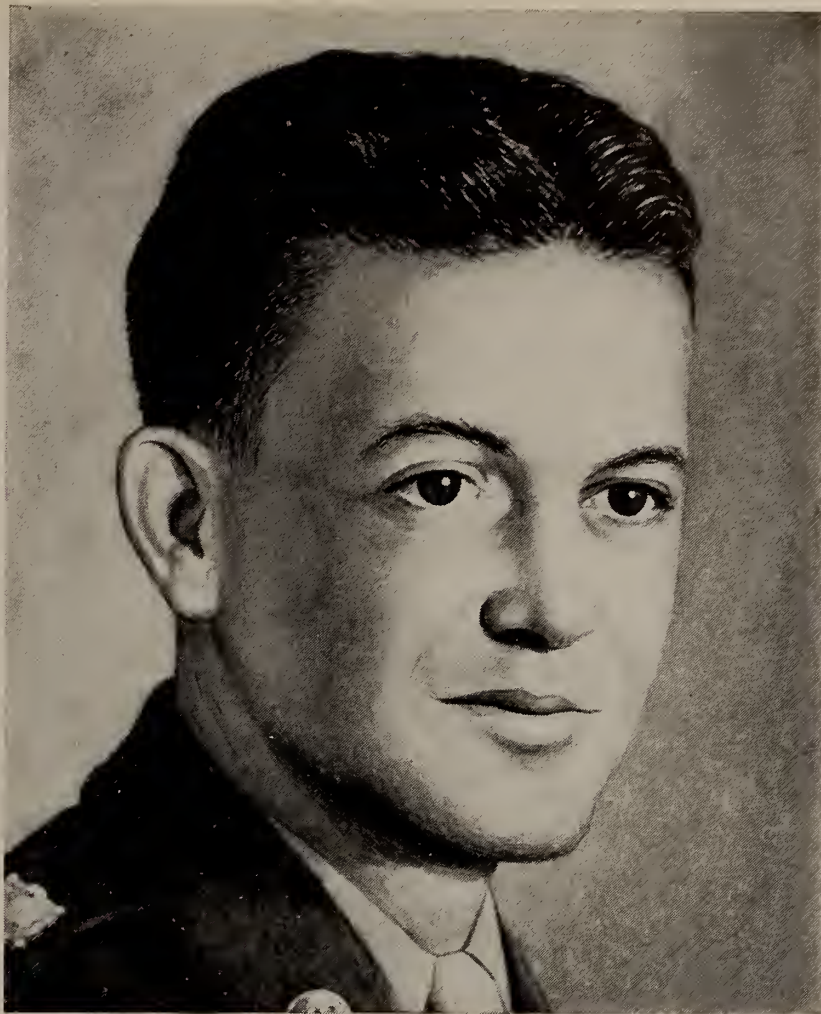

*Medal
of
Honor*



Master Sergeant Travis Watkins, of Gladewater, Texas—Medal of Honor. On September 3, 1950, near Yongsan, Korea, Sergeant Watkins was wounded and paralyzed from the waist down. Ordering his squad to pull out and leave him, he stayed behind and died covering their withdrawal.

Sergeant Watkins gave his life for freedom. What can you do?

This. You can begin today to do your share in defense of the country he defended far "above and beyond the call of duty" by buying more . . . and more . . . and more United States Defense* Bonds.

For your Defense Bonds strengthen America. And if you will make our country strong enough now, American boys may never have to give their lives again. Defense is *your* job, too.

Remember that when you're buying bonds for national defense, you're also building a personal reserve of cash savings. Remember, too, that if you don't save *regularly*, you generally don't save at all. So go to your company's pay office—now—and sign up to buy Defense Bonds through the Payroll Savings Plan. Don't forget that now

every United States Series E Bond you own automatically goes on earning interest for 20 years from date of purchase instead of 10 years as before. This means, for example, that a Bond you bought for \$18.75 can return you not just \$25 but as much as \$33.33! For your country's security, and your own, buy U. S. Defense Bonds now!

****U.S. Savings Bonds are Defense Bonds - Buy them regularly!***



The U. S. Government does not pay for this advertisement. It is donated by this publication in cooperation with the Advertising Council and the Magazine Publishers of America as a public service.

CENTURY THEATRES

MEADOWS

SHORE

BROOK

Simplex
REG. U.S. PAT. OFF.

**CHOSEN
AGAIN!**

ARGO

KINGSWAY



CENTURY CIRCUIT'S widespread chain of neighborhood theatres must maintain a consistently high standard of motion picture entertainment. And because there is no better way to guarantee the finest in motion picture enjoyment, they have chosen to install SIMPLEX X-L, the finest in motion picture projectors.

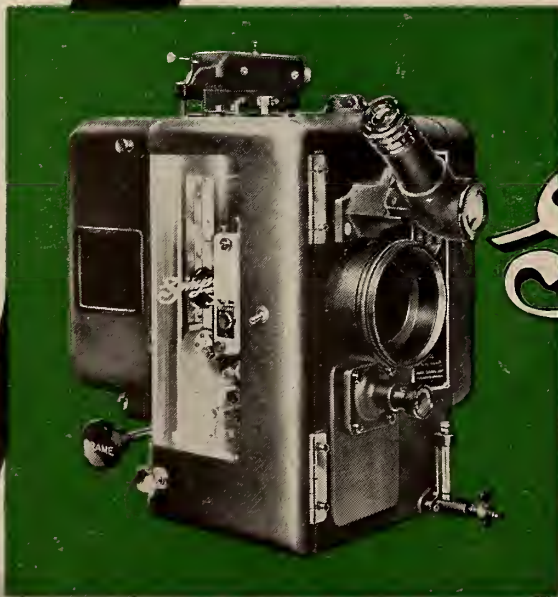

Simplex
TRADE MARK REG'D

X • L

PROJECTOR

TO RELAX SEE A MOVIE

MANUFACTURED BY INTERNATIONAL PROJECTOR CORPORATION • DISTRIBUTED BY NATIONAL THEATRE SUPPLY

PROJECTIONIST

INTERNATIONAL

IP



THE USE OF
SPECIAL PAPER

SEP 4 - 1951

AUGUST

1951

VOLUME 26



NUMBER 8

30c A COPY



\$2.50 A YEAR

ALONGSIDE THESE LAMPS STAND THE WORLD'S FINEST PROJECTIONISTS

Peerless

1-KW TO 70 AMPS

MAGNARC
TRADE MARK REG.

"HY-AX" ARC MAGNET

"HY-LUMEN" REFLECTOR

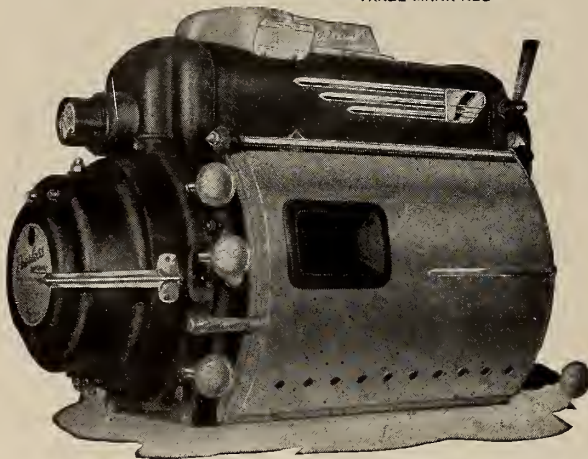

More light at 40 to 70 amperes than ever thought possible. . . Equals and excels any reflector lamp to 85 amperes, whether they be unapproved water-cooled or resurrected "Hi-Lows". . . Highest ratio of honest screen lumens per arc watt. . . At 70 amperes, using an accurated Glass Hy-Lumen Reflector*, with a projector having an efficient revolving shutter, it develops the maximum screen brilliance that can be used without a heat filter at no risk of film damage. . . Operating costs under these conditions are far below that of 85-ampere lamps.

Magnarc Lamps assure 80% side-to-center (SMPE Standard) screen light distribution, not a deceptive 60% or "Hot Center". . . They are all Und. Lab., Inc. listed. . . They are not insurance hazards. . . They are and have been for years "The First Choice" of large and small theatres, drive-ins, and the motion picture industry.

* Similar results are not guaranteed if all-metal reflectors are used.

"FIRST WITH THE FINEST"

130-180 AMPERES

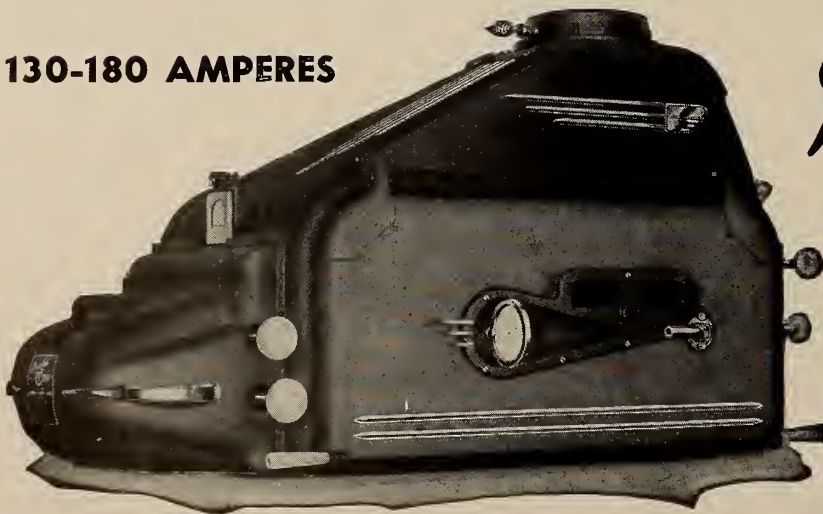

Peerless
HY-CANDESCENT
TRADE MARK REG.

NEW MAGNETIC STABILIZER

This modern lamp produces all the light there is. . . It is the standard equipment of the nation's largest and finest theatres. . . Used by 90% of the largest Drive-In Theatres.

It is the "Omega" for maximum screen brilliance. . . Nothing can even approach it in white light volume when used with projectors that have efficient revolving shutters.

Assures satisfying projection for Drive-Ins regardless of the size of the picture, length of throw, and under all weather conditions. . . They are Und. Lab., Inc. listed and, therefore, not insurance hazards. . . Heat filter assures no risk of film-heat damage at maximum arc amperage and maximum screen lumens.

"WHY EXPERIMENT?"



J.E. McAULEY MFG. CO.

552-554 WEST ADAMS STREET
CHICAGO 6, ILLINOIS

INTERNATIONAL PROJECTIONIST

With Which Is Combined PROJECTION ENGINEERING



HENRY B. SELLWOOD, *Editor*

Volume 26

AUGUST 1951

Number 8

Index and Monthly Chat	3	Eidophore Tv With Color	22
The Magic of Color, IV	5	SMPTE Out of FCC Hearing	22
ROBERT A. MITCHELL		New RCA Magnetic Recorder-	
New All-Purpose Film Leader	9	Projector	23
SMPTE COMMITTEE REPORT		Current IA-IP Amateur Radio	
Stereoscopic Motion Pictures	12	Listing	24
J. A. NORLING		TV Viewing Difficulty Corrected	
'Natural Vision' Latest 3-D (?)		by B. & L. Tele-Ban	25
Entry	14	IA-IP Radio 'Hams' a Theater	
Training British Projectionists	15	Tv Backlog	25
The Matching of Loudspeakers	16	Cleaning Projector Lenses	26
JOHN F. RIDER		Letters to the Editor	26
Carbon Arc Copper Salvage	17	News Notes	
In the Spotlight	20	Technical Hints	
HARRY SHERMAN		Miscellaneous Items	

Published Monthly by

INTERNATIONAL PROJECTIONIST PUBLISHING CO., INC.

19 West 44 Street, New York 18, N. Y.

Telephone: MURRAY HILL 2-2948

R. A. ENTRACHT, Publisher

SUBSCRIPTION REPRESENTATIVES

AUSTRALIA: McGills, 183 Elizabeth St., Melbourne

NEW ZEALAND: Te Aro Book Depot, Ltd., 64 Courtenay Place, Wellington

ENGLAND and DOMINIONS: Wm. Dawson & Sons, Ltd., Macklin St., London, W. C. 2

YEARLY SUBSCRIPTION: United States and possessions, \$2.50 (two years, \$4); Canada and foreign countries, \$3; single copies, 30 cents. Changes of address should be submitted two weeks in advance of publication date to insure receipt of current issue. Entered as second class matter February 8, 1932, at the Post Office at New York, N. Y., under the act of March 3, 1879. Entire contents copyrighted 1951 by International Projectionist Publishing Co., Inc. INTERNATIONAL PROJECTIONIST is not responsible for personal opinions appearing in signed articles in its columns.



MONTHLY CHAT

THREE facets of the news, all significant and all interwoven: three-dimensional movies *without* a viewing aid are a reality; competency still is the payoff for the professional projectionist (we have nothing else to sell), and there still are industry-wise people who are adamant in their determination not to sell short the motion picture industry.

Stereoscopic motion pictures have been available to these salary-conscious brains (?) of the film business for several years now. This is a *fact*, disputed by nobody with even average intelligence. The same quality of brains that wrought the miracle of Tv has long been available to those whose innate caution and terrific concern with their annual take ("after me the deluge") has militated against the best interests of the industry which made it possible for them to wear their first clean shirt.

RCA, wise in the ways of finance and trade, announces publicly that it stands ready to invest millions of dollars in the future of the motion picture theater. No philanthropy here—just sound business sense. Meanwhile, the industry brass sits back and look to somebody else to carry the ball.

Sure, they go through the motions of "exploring" this and that possibility for perking up the movie box-office—but their safaris are strictly of Boy Scout nature. Bilk the exhibitor, cut down the number of lamps on a set, and attend industry functions at the Waldorf-Astoria—these are the contributions of the "brains" of this business.

Nor has Labor been too active in its own behalf: with some 60,000 working men and women dependent upon the survival of the movie industry, Labor has contributed pretty much of nothing to that technological progress which alone can provide security for its own. As for competency—read elsewhere herein how the British purpose providing a steady flow of technical competency. Pretty high standards—yes?

No oracle the writer of these lines, but it must be pretty obvious to even the dolt that concerted action by all branches of the movie industry is necessary in order to keep things on a fairly even keel. Mr. Charles and Mr. Zilch may collect such unconscionable salaries as \$900,000 annually—but this serves only to deplete not add to industry resources.

We can dispense with the Mr. Charles and the Mr. Zilch, but we as working people should not stand idly by and see washed away in a wave of incompetency that which provides sustenance for our own. By which we mean that the biggest stake in this business of ours is that of the workers—and if they remain passive, they may now pick their own economic burial ground.

These gloomy-sounding words may be readily transposed to the bright, sunny side of the street if the will to do so is exercised.

A MATTER OF

Good Judgment



For the
**BRIGHTEST
PICTURES**

On the
**LARGEST
SCREENS**

At the
**LOWEST
OPERATING
COST**

It's the

NATIONAL EXCELITE

75 to 130 ampere high intensity reflector type

PROJECTION ARC LAMP

- Air-cooled rotating positive carbon feeding mechanism.
- Big 16½" reflector matches high speed f/1.9 lens.
- Automatic arc crater positioning.
- Stable burning and complete combustion at the arc, to avoid any black soot, are attained by a jet of air directed just above the arc.
- White smoke, which would otherwise cloud the mirror, is also diverted by this air stream.
- Unit construction permits instant removal of components for cleaning.

Distributed by



"THERE'S A BRANCH NEAR YOU"



YOU'RE RIGHT! IT'S BRIGHT! IT'S EXCELITE!



The Magic of Color

By ROBERT A. MITCHELL

IV. Color Film Processes

MOST interesting is the modification of the additive color method by the Lumiere Autochrome process, used for making colored transparencies on glass plates. The glass side of a panchromatic photographic plate is coated with a special emulsion containing innumerable tiny grains of starch dyed vermilion, emeraude, and indigo. The plate is placed in the camera with the photographic emulsion away from the lens. All of the light striking the emulsion must accordingly pass through the colored starch grains, which act as filters.

The Autochrome negative, upon development, has everything in reverse, including the colors. So the plate is reversal—processed to turn it into a positive. The white areas are entirely cleared of silver in the positive, just as in an ordinary print on a lantern slide. But white on an Autochrome plate looks white only because these areas are viewed by equivalent quantities of vermilion, emeraude, and indigo light. The colored starch grains remain permanently on the back side of the plate.

A yellowish green leaf appears yellowish green on the Autochrome plate simply because the silver deposit has been removed from behind the emeraude starch grains, but remains behind the vermilion and indigo grains, thus covering up those two colors.

The Autochrome process was adopted

by Agfa and called Agfacolor. Instead of starch grains, however, Agfa used colored resin grains. Modern Agfacolor, however, is an entirely different type of process.

This additive process might seem usable for colored movies, but such is not the case. It has two serious disadvantages. It is unavoidably grainy. It cuts down light transmission to such an extent that the clearest whites are really neutral grays which allow only about 25% of the light to pass.

Rigid Tricolor Requisites

Tricolor motion picture processes have to meet two very rigid requirements in addition to the prime requisite of reasonably faithful color reproduction throughout a wide range of light intensities. First, such processes must permit the preparation of a large number of theatre-release prints. Second, the character of the prints must be such that adequate picture illumination can be obtained from existing standard projection equipment.

It is the second of these requirements which definitely rules out additive processes. Only *subtractive* color methods can be used successfully in the professional 35-mm field.

In the days of 2-color motion pictures, Technicolor, with its imbibition method of printing release positives, proved itself the peer of all existing movie color

processes. But shortly after the advent of sound pictures, Dr. Kalmus felt that the 2-color process was no longer adequate. He accordingly directed his efforts towards the building of vastly improved Technicolor cameras and processing machinery.

First 3-Color Technicolor

Much scientific research and a large outlay of capital lay back of the first 3-color Technicolor camera and the new processing plant, first ready for use early in 1932. The first production thus filmed was a 2-reel short titled *La Cucaracha*. Walt Disney immediately adopted the new medium. The first full-length feature in tricolor Technicolor was *Becky Sharp*.

There are three ways of filming a Technicolor "separation" negative. The simplest method consists of exposing three frames in succession through vermilion, emeraude, and indigo filters. This method, obviously not suitable for photographing scenes in motion, is confined to the animated cartoon. Three matrix positives are made from the single negative by means of a step printer which prints every third frame of the negative. One matrix, therefore, is the vermilion record, the second is the emeraude, and the third the indigo record.

The standard method of filming in Technicolor involves a special camera which makes use of the beam-splitting principle. But even though three separate negatives, one for each primary color, are made by the Technicolor camera, the beam-splitting device produces only two identical images of the scene being photographed. How then, does this camera produce three negatives?

A prism of special design is positioned directly behind the lens. Part of the light passes straight through the prism

and through an emeraude filter to a panchromatic negative film which records the scene by emeraude light.

The remainder of the light from the lens is reflected at a right angle to form an image of the scene in a second picture aperture. *Through this aperture two negatives run together in "bipack."*

Sensitive Film Layers

The film nearest the prism has a standard emulsion sensitive only to indigo light, thus becoming the indigo record of the scene. But this film also acts as a filter for the film behind it, and which runs in contact with it. For this purpose the indigo-recording film is backed by a layer of vermilion-dyed gelatine. It therefore acts as a light-filter for the rear film of the bipack, a very sensitive panchromatic negative, which records the scene by vermilion light.

In this way the Technicolor camera, although forming only two picture images, photographs three negatives simultaneously, each negative being a record of the scene in one of the three primary colors.

The third method of filming Technicolor, which is enjoying increasingly wide use, requires only an ordinary one-film motion picture camera and a special "monopack" color negative. How this single negative actually records a scene in full natural color will be described in connection with Agfacolor and Kodachrome.

But no matter which of these three methods of photographing Technicolor are used, three separate matrix films must be printed, one for each primary. The monopack color negative is usually reversal-processed, converting it to a "direct positive" in full natural color. From this "original" three negative records are made by running it three times through a film printer, a different primary color filter being used in the printer at each operation. Matrices are then printed from the three separation negatives.

The black-and-white matrices are subsequently processed and imbibition-

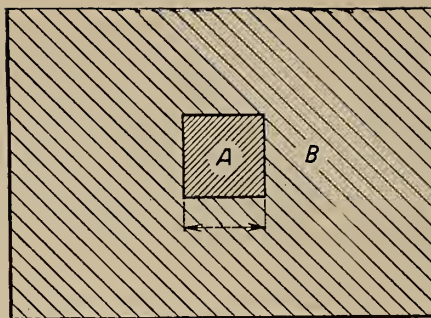

The chromatic adaptation of the eye is very well demonstrated by illuminating a transparent window A with a light of a certain color and the surrounding field, B, first with artificial daylight, for instance, and then with incandescent light. Shortly after changing over from daylight to lamplight the eye directed upon A sees a change of color in the window.

printed as previously described for old-style Technicolor. Each matrix is, of course, printed in the color which is exactly complementary to the color of the filter used in photographing the negative from which it was made.

These primary complementaries (secondary colors) are *yellow* (true yellow, complementary to indigo), *magenta* (a decidedly purplish red, complementary to emeraude), and *cyan* (a slightly greenish blue, complementary to vermilion).

Subtractive Process Example

The new Technicolor, like the old 2-color process, is thus a subtractive process. Suppose yellowish green foliage is photographed. Foliage of this color comes out: (1) black on the matrix-positive made from the vermilion-exposed negative, (2) white on the matrix printed from the emeraude negative, and (3) black on the matrix printed from the indigo negative.

In imbibition-printing from these matrices, the foliage is printed: (1) cyan from the cyan-inked vermilion matrix, it is printed clear (no color at all) from the (2) magenta-inked emeraude matrix, and (3) yellow from the yellow-inked indigo matrix. Cyan and yellow super-

imposed give the true emeraude color of the foliage.

The "subtraction" of colors from the white light of the projector may be described this way: cyan and yellow subtract their complementaries (the primary colors vermilion and indigo, respectively) from the white projection light. Only one primary component of the light remains, emeraude, to pass on to the screen to form an image *in natural color* of the emeraude foliage.

The Printing Procedure

In the actual imbibition-printing of modern Technicolor, yellow is printed first, then magenta, and finally cyan. The printing stock is regular positive film which has previously been printed with the soundtrack and framelines in silver image. The reason why the soundtrack must be in silver is because all the Technicolor dyes, including the cyan, are nearly transparent to infrared light. Although invisible to the eye, infrared affects the modern red-sensitive type of photoelectric cell. A track printed in Technicolor dyes would therefore give very feeble sound.

Hold up a strip of "black" Technicolor film to the light—a fadeout, for example. Instead of being truly black, the film will appear dark red. This shows that the cyan dye, which *theoretically* should cut off *all* red light, transmitting only emeraude and indigo, actually does allow the "low red" to pass. And it is even more transparent to the invisible infrared rays.

Technicolor Print Misalignment

It was formerly the practice to overprint the Technicolor dye-images with a faint silver image to assist the correct balance of color values. Recent improvements in Technicolor make this practice less necessary. As a result, the purity of colors in a Technicolor print is very high, and the over-all color balance practically perfect. Of all the movie color processes, Technicolor reigns supreme.

One minor criticism may be directed

(Continued on page 32)

Color Temperatures of Light on the Projection Screen with Various Carbon Arc Projection Systems

Lamp	Carbon Trim	Amperes	COLOR TEMPERATURE	
			Absolute	Fahrenheit
Low Intensity Lamp	12-mm-8-mm Low Intensity	30	3870	6500
Lamp for "Pearlex" Trim	6-mm-5.5-mm "Pearlex"	30	4450	7550
"One Kilowatt" d-c Lamp	7-mm "Suprex" Positive-			
	6-mm "Orotip" C Negative	40	5300	9080
"One Kilowatt" a-c Lamp	7-mm-7-mm "Suprex" Positives	52	5260	9010
		65	5420	9300
Simplified H.I. Lamp	7-mm "Suprex" Positive-	42	5020	8580
	6-mm "Orotip" C Negative	50	5060	8650
Simplified H.I. Lamp	8-mm "Suprex" Positive-	65	5340	9160
	7-mm "Orotip" C Negative	70	5270	9030



NEWEST PLOT in the world...

Boy meets girl is one of the oldest plots in the world. Yet in the hands of today's writers, directors, and technicians it is the newest—sparkling, ever fresh.

Great credit is due these men—their imagination and their skill in the use of modern equipment and materials.

The Eastman Kodak Company is proud of the part it has been able to play. Through the Eastman Technical Service for Motion Picture Film, it helps studios in the selection, exposure, and processing of black-and-white and color film; helps laboratories in setting up control systems and to establish new standards of quality and economy; helps exchanges and exhibitors—always making sure that each foot of film produces optimum results, gets its best showing.

In carrying out this work, the Eastman Kodak Company maintains branches at strategic centers, invites inquiries from all concerned. Address:

Motion Picture Film Department

EASTMAN KODAK COMPANY, ROCHESTER 4, N. Y.

East Coast Division
342 Madison Avenue
New York 17, New York

Midwest Division
137 North Wabash Avenue
Chicago 2, Illinois

West Coast Division
6706 Santa Monica Blvd.
Hollywood 38, California

THE NATIONAL CARBON

TRADE-MARK

ARC'S BIG FIVE:

- ★ small-source size
- ★ terrific brightness
- ★ great power from one unit
- ★ white light
- ★ minimum heat per foot-candle

make it indispensable on movie sets!

THE "National" carbon arc offers an ideal combination of the qualities most desirable in a studio light. The carbon arc's small-source size — less than one quarter square inch — insures sharp shadows, simulates one-source lighting better, creates a perfect "follow-spot." The carbon arc's high brightness penetrates deep sets, establishes high light levels without excessive heat, creates better the illusion of a third dimension. The carbon arc's great power from one unit cuts illumination pathways through general set illumination, boosts daylight, lights large sets so generously that camera-lens apertures may be reduced and great depth of focus obtained. The carbon arc's white light matches outdoor shooting conditions, lends itself better to filters because it has equal quantities of blue, green and red and, finally, makes colored objects appear visually the same inside and outside.

There is no substitute for the carbon arc.

**MORAL: YOU CAN'T SKIMP ON STUDIO LIGHTING
WITHOUT RISKING BOX OFFICE!**



*When you order studio
or projector carbons —
order "NATIONAL"!*

The term "National" is a registered trade-mark of
Union Carbide and Carbon Corporation

NATIONAL CARBON COMPANY

A Division of

Union Carbide and Carbon Corporation

30 East 42nd Street, New York 17, N. Y.

District Sales Offices: Atlanta, Chicago, Dallas,
Kansas City, New York, Pittsburgh, San Francisco

IN CANADA: National Carbon Limited
Montreal, Toronto, Winnipeg

NEW

ALL-PURPOSE

FILM

LEADER[†]

This proposal for a new film leader has been under extensive and exhaustive tests by an SMPTE committee. Designed to best serve the interests of all film users, in both the theater and Tv fields, a report on this proposed leader is herewith offered for constructive criticism by all branches of the film industry.

THE Subcommittee on Film Leaders has worked to produce a new leader design retaining all the excellent features of the Academy Leader now in general use, and providing some features which are highly desirable from the viewpoint of a new and growing user of film productions — television. It is believed that this has been accomplished.

Early in the work a purely Tv centered program was abandoned in favor of a broadly applicable design. Since then the leader has been tested by commercial laboratories, professional theater projectionist groups, and equipment manufacturers. Several Tv vision companies have been using the new leader on their recording releases and on certain other Tv films. More than 10,000 prints have been so made and used with excellent results.

It is hoped that all interested persons will consider the proposed leader carefully, use it widely for test and evalua-

tion, and send the Subcommittee their findings. It is the intention that a proposal for standardization shall be made when widespread results warrant it.

Features of the New Leader

The present American Standard Z22.55-1947 is the foundation for the new leader design. Only additions have been made, and only such additions as cause no deletion of past features. Under Z22.55, paragraphs (1) and (2) remain unchanged. Paragraph (3) is changed only as to frame content, and paragraphs (4), (5), (6) and (7) are unchanged.

2.1: *The main body of the leader ahead of the three-foot mark is changed from a solid black to an appropriate simple pattern (see illustration). The design is intended to be used in Tv to permit checking system operation before switching into the first picture frame.*



SAMPLE FOOTAGE FROM PROPOSED LEADER

Read from the upper left to the lower right; broken edges indicate duplicate frames deleted.

The basis of the pattern is familiar to most Tv engineers. A neutral gray background provides a foundation for the pattern proper, which consists of two concentric circles having diameters in the ratio of 4:3, and four arrows whose tips establish the limits of scanning as defined by the SMPTE Tv Test Reel.

Tv Reference Levels

Approximately equal areas of black and white are used to provide reference levels for video gains and pedestal settings. These two limits, together with the background gray, provide a rough check of system transfer characteristic, since the gray value used is approximately centered between the black and white tones. Experience will indicate where the gray level should fall on the wave-form monitor when the system pro-

† J. Soc. Mot. Pict. Eng., May, 1951.

vides best reproduction. The assigned density values of these areas are:

White	0.2 ± 0.1
Gray	1.0 approximately
Black	2.0 ± 0.2

The pattern also provides a secondary indication of scanning adjustment and camera-projector alignment. This will greatly reduce the need for "blind" switching; that is, for switching into a film sequence from equipment having only accidental scanning control settings.

Much of the foregoing information can be gained during the rolling time of a normally threaded leader. In addition, when stop-frame projection is available (its use is rapidly increasing), the projected pattern permits advance check of the entire electrical system, including effects of beam current, edge-light, back-light, etc. Also, the presence of the "average video" information between cue numbers reduces the tendency of the system to "bounce" as the cues go by.

Footage Numbers Changed

2.2: *The footage numerals* have been changed to project right side up. It has been found that precise Tv program switching has caused these numerals to become of great value to program directors. They can count to their first-frame cue from the rhythm set by the passing numerals, resulting in excellent switching accuracy. Rightside-up projection makes them easier to read for this service. To prevent errors of reading by both production directors and projectionists the "SIX" and "NINE" markers are spelled out.

2.3: *The picture threading frame* for each 35-mm foot is identical with the old leader, consisting of a full white background with black numerals overlaid. No threading problems are introduced there. However, a single frame, when projected, does not have enough visual effect to permit positive recognition of the numeral; therefore, each numeral is repeated one frame before and one frame after each threading frame, but with the outer portions of the main target design added.

As seen in the illustration, there is no possibility of confusing the threading frame with those added for visual effect. This permits normal threading procedures used in theater projection to continue without modification.

Sound Threading Marks

2.4: *The 35-mm sound threading marks* have been changed to read in plain English "35 Sound," replacing the previously used diamond mark. No explanation of function is necessary, therefore, for persons unfamiliar with the use of a leader, as was the case before this change. The lettering used is right-side up to the projectionist, and on the side of the

film occupied by the sound track. No change in threading procedure is required.

2.5: *16-Mm sound threading marks* have been added to define the sound scanning position for that service. As in the 35-mm case, the sound mark reads in plain English and occurs on the side of the film next to the sound track. The leader can thus be used for both reduction printing and contact work without change.

Previously no indication was provided of proper threading for 16-mm use. Yet it has been found that most projectors can be misthreaded. Past practice, in cases of controversy, has been to count 26 frames and mark the sound position with grease pencil. No problems of this sort need occur with the new leader. Of course, the presence of an indication of correct threading position also increases the precision of ordinary operation.

Black Frames Altered

2.6: *The black frames following the three-foot marker* are slightly changed to a dark gray. The tone value is not altered enough to affect theater projection, but will permit Tv operations to switch into the dark frames without as much "flare" and "black-spot" as now occur. No change in theater practice is required.

The density value used for these frames is approximately 1.6 but may vary somewhat, depending upon printing conditions. In general, the intention is to provide some iconoscope plate illumination to stabilize its operation.

2.7: *A small switching cue* (see illustration, third frame above lower right-hand corner) has been added in the

eight dark frame before the first frame of picture. The cue is the standard mark used for changeovers but confined to one frame. It is to be used as an indication to Tv directors that the picture will start within normal switching reaction time. Since the cue is very small, occurs only on one frame, and is on a part of the side of the film not normally shown in theaters, it will not affect theater practice in any way.

The switching cue also gives a clear indication to a cutter when a particular leader has been used too often, resulting in excessive loss of frames due to splicing. A few frames can be lost without serious consequences, but when their number exceeds four or five, that leader should not be re-used.

Reel Identification

2.8: *Reel identification standards* have not been changed. It is worth noting, however, that nonstandard practices have grown up, particularly in Tv filmmaking. American Standard Z22.55-1947 defines proper procedures and should be followed rigorously. The proposed leader is carefully designed to supply needed information throughout its active length. It should not be mutilated by slates or special markings in any position other than the standard allows or its usefulness will be greatly impaired.

3.1: *Any new thing is strange* at first, inevitably. Every effort has been made to reduce this strangeness by retaining unimpaired the previous functions of the leader. But each new function has introduced some new appearance. It is suggested that evaluation be a slow process, with time for all to become familiar

(Continued on page 31)

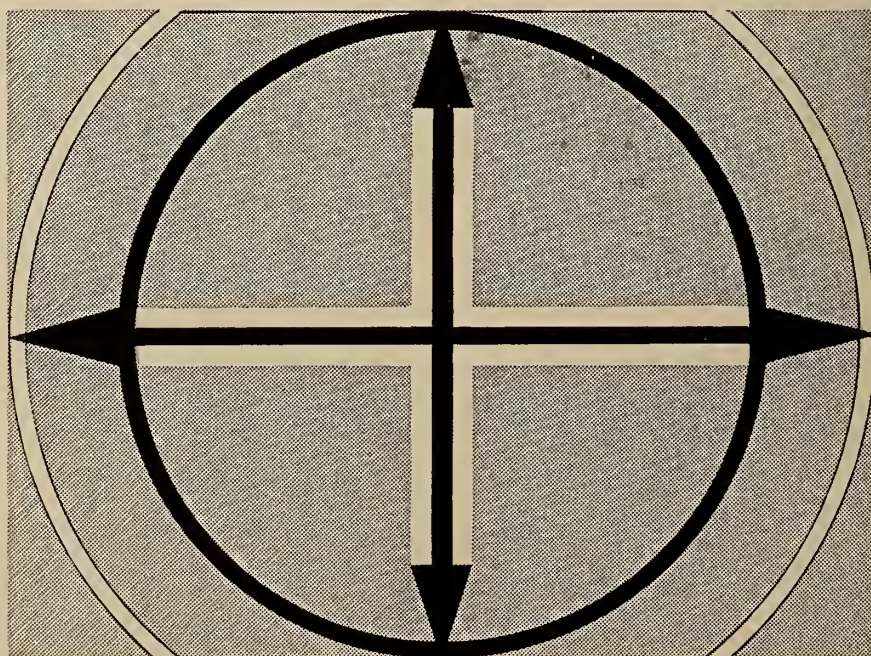

Main body pattern of proposed identification for standard leader.

Strong

PUTS A

SNOW-WHITE LIGHT

ON YOUR ATTRACTIONS



TROUPER

A sharp, brilliant spot . . . quiet, flickerless, portable . . . is yours without the use of heavy rotating equipment when you use the Strong Troupier or Troupierette.

The Troupier High Intensity Arc Spotlight is ideal for theatres, auditoriums, arenas, hotels, ice shows, schools, colleges and lodges. It draws only 10 amperes from any 110-volt A.C. convenience outlet. An adjustable, self-regulating transformer is an integral part of the base. A two-element variable focal length lens system and silvered glass reflector account for much of the efficiency of this spotlight. It has an automatic arc control. A trim of carbons burns one hour and 20 minutes at 21 volts and 45 amperes. The Troupier is easily disassembled for shipping.

The Troupierette Incandescent Spotlight is particularly adapted to the needs of night clubs, small theatres and schools where physical

dimensions and price are factors. As contrasted to conventional incandescent spotlights, with which the spot size is varied solely by iris, to result in substantial light loss, the Troupierette utilizes all the light through most of the spot sizes. This results in head spots which are 6½ times brighter. Sharp edges are maintained from head spot to flood. Features include a variable focal length objective lens system, 5¼" silvered glass reflector, Fresnel lens, fast operating color boomerang which accommodates six slides and a height adjustable mounting stand. The horizontal masking control can be angled at 45 degrees in each direction. The Troupierette uses a standard 115-volt, 1000-watt prefocused projection type bulb and plugs into any 110-volt convenience outlet.



TROUPIERETTE

SEE ANY OF THESE DEALERS OR USE COUPON FOR OBTAINING LITERATURE.

ALBANY, N. Y.—Nat'l Theatre Supply Co.; Albany Theatre Supply
 ATLANTA—Nat'l Theatre Supply Co.
 ATLANTIC CITY—Boardwalk Film Enterprises
 AUBURN, N. Y.—Auburn Theatre Equipment
 BALTIMORE—J. F. Dusman Co.; Nat'l Theatre Supply Co.
 BIRMINGHAM—The Queen Feature Service, Inc.
 BOSTON—J. Cifre, Inc.; Nat'l Theatre Supply Co.
 BUFFALO—Dion Products; Nat'l Theatre Supply Co.
 CHARLOTTE—Nat'l Theatre Supply Co.; Standard Theatre Supply Co.
 CHICAGO—Abbott Theatre Equipment Co.; Droll Theatre Supply Co.; Gardner Jansen, Inc.; Grand Stage Lighting Co.; Hollywood Stage Lighting Co.; Midwest Stage Lighting Co.; Nat'l Theatre Supply Co.
 CINCINNATI—Nat'l Theatre Supply Co.
 CLEVELAND—Nat'l Theatre Supply Co.
 DALLAS—Hardin Theatre Supply Co.; Modern Theatre Equipment Co.; Nat'l Theatre Supply Co.
 DENVER—Nat'l Theatre Supply Co.; Graham Bros.
 DES MOINES—Nat'l Theatre Supply Co.
 DETROIT—Nat'l Theatre Supply Co.
 FORTY FORT, PA.—V. M. Tate Theatre Supplies
 GREENSBORO, N. C.—Standard Theatre Supply Co.
 HOUSTON—Southwestern Theatre Equipment Co.
 INDIANAPOLIS—Nat'l Theatre Supply Co.
 KANSAS CITY, MO.—Shreve Theatre Supply; Nat'l Theatre Supply Co.
 LOS ANGELES—J. M. Boyd; C. J. Holzmueller; Nat'l Theatre Supply Co.; Pembrex Theatre Supply Corp.
 LOUISVILLE—Falls City Theatre Supply Co.
 MEMPHIS—Nat'l Theatre Supply Co.

MILWAUKEE—Nat'l Theatre Supply Co.; R. Smith Co.
 MINNEAPOLIS—Minneapolis Theatre Supply; Nat'l Theatre Supply Co.
 NEW HAVEN—Nat'l Theatre Supply Co.
 NEW ORLEANS—Nat'l Theatre Supply Co.
 NEW YORK CITY—Nat'l Theatre Supply Co.
 NORFOLK—Nat'l Theatre Supply Co.
 OKLAHOMA CITY—Nat'l Theatre Supply Co.; Oklahoma Theatre Supply Co.; The Century Theatre Supply Co.
 PHILADELPHIA—Blumberg Brothers; Nat'l Theatre Supply Co.
 PITTSBURGH—Atlas Theatre Supply; Nat'l Theatre Supply Co.
 SALT LAKE CITY—Inter-Mountain Theatre Supply Co.
 SAN FRANCISCO—C. J. Holzmueller; Nat'l Theatre Supply Co.; W. G. Preddey Theatre Supplies

SEATTLE—B. F. Shearer Co.; Nat'l Theatre Supply Co.
 SIOUX FALLS—American Theatre Supply Co.
 ST. LOUIS—City Electric Co.; Nat'l Theatre Supply Co.
 TOLEDO—Theatre Equipment Co.
 WESTERLY, R. I.—G. H. Payne Motion Picture Service

CANADA—
 Dominion Sound Equip., Ltd., Montreal, Que.
 General Theatre Supply Co., Toronto, Ont.
 General Theatre Supply Co., St. John, N. B.
 General Theatre Supply Co., Vancouver, B. C.
 General Theatre Supply Co., Montreal, Que.
 General Theatre Supply Co., Winnipeg, Man.
 Perkins Electric Co., Ltd., Montreal, Que.
 Perkins Electric Co., Ltd., Toronto, Ont.
 Sharp's Theatre Supplies, Ltd., Calgary, Alta.

THE STRONG ELECTRIC CORPORATION

"The World's Largest Manufacturer of Projection Arc Lamps"

14 CITY PARK AVENUE

TOLEDO 2, OHIO

Please send free literature on the Strong Troupierette Incandescent Spotlight;

Strong Troupier Arc Spotlight.

NAME _____

COMPANY _____

STREET _____

CITY & STATE _____

Stereoscopic Motion Pictures

By J. A. NORLING

President, Loucks & Norling Studios, Inc., New York

A comprehensive summary of the present status of a technical development which has been receiving increasing attention and exploration by the motion picture industry—although mostly on the “thinking” side. The writer is an outstanding authority on the art, his various three-dimensional movies having received world-wide acclaim.

NO GRAPHIC means, beside the stereogram, can substitute for the re-creation of the “real” in a still-life, and in stereo movies realism reaches the ultimate, for they can include movement, color, and action as well as depth. The principles employed in photographing and projecting stereoscopic slides also apply to stereoscopic motion pictures. The same fundamental requirement that each eye sees only the picture intended for it also applies to the moving stereogram.

35-mm Movie Stereoscropy

It seems incredible to many of us who have worked with three-dimensional pictures that the vast motion picture industry does not have a stereoscopic engineering and development research program. The only joint engineering get-togethers are the meetings of the Society of Motion Picture and Television Engineers, and it is at a very few of these meetings that three-dimensional photography processes are presented.

But whenever the subject of three-dimensional films comes up, there is a remarkable response from the members present, and also from the press. The art of stereoscropy has “sex appeal,” but it seems to have escaped the concentrated attention of most of the people in the Hollywood area. The men in the drivers’ seats of the movie industry have, for the most part, failed to have a vital personal interest in and understanding of three-dimensional movies.

Formidable Competition to Tv

That the industry could use something to combat television’s capture of more and more of the theatre audience

is undeniable. Stereo movies might well induce people to return to their former favorite amusement. But the return is likely to come about in the mass only if the film theatre gives them something they can’t get on a 17-inch Tv tube, namely the ultimate in photographic realism, the stereoscopic movie in full color, with all the dramatic possibilities that are only waiting to be appreciated.

The enthusiastic public reception given some earlier stereo movies and the dollar profits from these movies are a matter of record. Newer, better stereo techniques are now available, and the reason for introducing them was never more pressing. Will the motion picture industry take action?

Early Anaglyph Process Films

One of the early and noteworthy theatrical exhibitions of stereoscopic motion pictures occurred in 1924, when J. F. Leventhal produced a few “shorts” utilizing the anaglyph process. There followed an eleven-year lull in the use of stereoscopic films.

•
The Norling
three-dimensional
camera for stills.
It has provision
for variable lens
interaxial and
convergence.
•

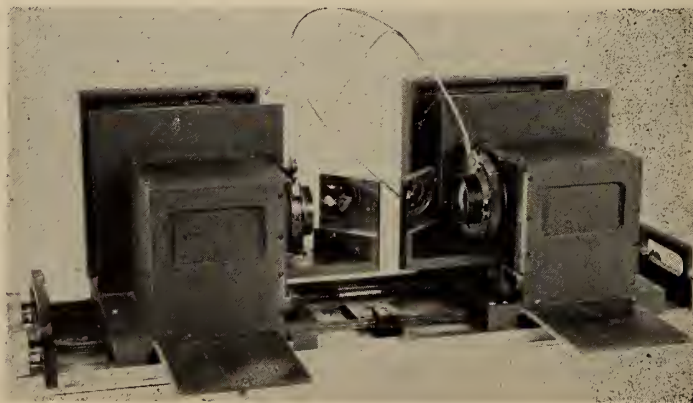

Then, in 1935, Loucks and Norling Studios and Mr. Leventhal jointly produced a series of short films again employing the anaglyph principle, this time in talking picture form. These films, which were called “Audioscopiks,” were released by Loews, Inc. and proved to be some of the most successful short subjects ever issued, winning not only domestic acceptance but an unprecedented play in the foreign field, notably in France, Spain and Great Britain.

That their success should have indicated further pursuit of the anaglyph process seems logical. But the producers had, from the beginning, realized the inherent limitations of the anaglyph process and concluded that films exhibited by that process would only be adequate as novelties and would never be tolerated for full-length feature releases.

‘Retinal Rivalry’ Induced

This conclusion was arrived at by a recognition of the visual “insult” resulting from the projection of one color to one eye and its complementary to the other. This sort of delivery of images, one color to one eye, another to its mate, produces “retinal rivalry” and brings on physiological disturbances that may induce nausea in some observers if they look at the anaglyph longer than a few minutes.

Since this process—the anaglyph—has played an important role in the advance of the stereoscopic art, it would be well to describe it here briefly. Its invention is credited to Ducos du Hauron, who applied it in 1895, although there is some evidence that its possibilities had been explored many years before that.

The Viewing Process

In one form, the anaglyph images are on two separate films. One member of the stereoscopic pair is projected through a filter of one color, the other through a filter having a color complementary to that of the first. In another form, the one that was used for “Audioscopiks,” the anaglyph images are printed in complementary colors directly on film and

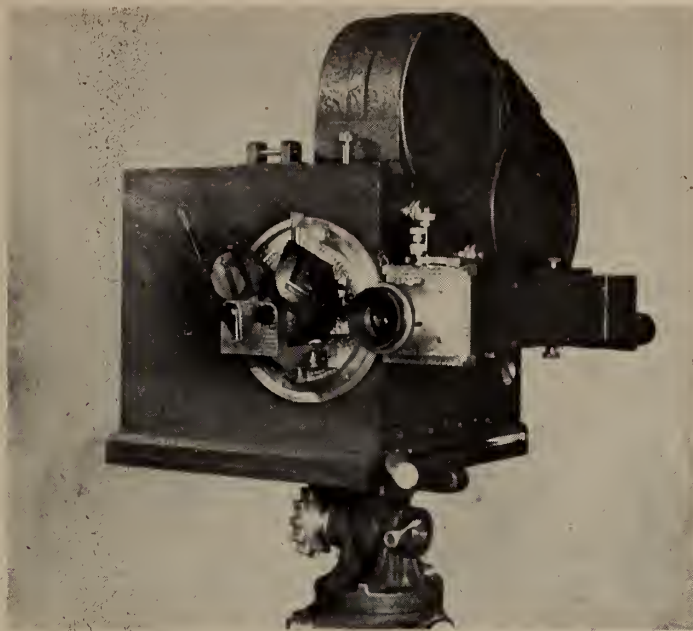

•
Front view
 of the Norling
 three-dimensional
 motion picture
 camera, showing
 variable interaxial
 optical system
 in front of the
 two lenses.
 •

projected in a standard projector without filters.

The projected images are viewed with spectacles having windows of the same colors as the colors on the screen. Red-orange for the right eye filter and blue-green for the left are often used. The right-eye red-orange filter in the viewing spectacle renders the blue-green right-eye image in monochrome and the left-eye blue-green filter renders the red-orange left-eye image also in monochrome.

Since dyes and pigments hardly ever are capable of transmitting only the color they are supposed to transmit, there is rarely a complete "cutting" of one color: some of it always comes through so that part of the blue-green image which is supposed to be blocked by the blue-green spectacle filter leaks through, producing a "ghost" image. So, in reality, the one eye sees a part of the image intended for the other; the "part," of course, being defined as a very dim, but still discernible remnant of the whole "other-eye" image.

Good picture quality has never characterized the colored anaglyph. This and other shortcomings make it eligible for discard as a practical system for motion picture features.

Since the introduction of Polaroid light-polarizing filters it is possible and practical to substitute these for the red and green filters of the original anaglyph process. Strictly speaking, the polarized light method may be defined as another form of the anaglyph. Actually, Polaroid Stereoscopes would be a good name for it. It was Dr. Edwin H. Land, head of Polaroid Corp., and his invention of the first practical and efficient synthetic polarizer which hastened the increasingly widespread use of the present satisfactory methods of stereoscopic projection.

World's Fair (1939) Film

The first large-scale public exhibition of a stereoscopic motion picture with excellent picture quality took place in 1939 at the New York World's Fair. That year a black-and-white film was shown. The following year a similar subject was exhibited in Technicolor. More than five million people saw these films,* and they're still talking about them. Some of the production and exhibition problems posed by these pictures are interesting to consider.

The camera assembly for the black-and-white picture consisted of two Bell and Howell professional 35-mm cameras mounted so that one was "upside down" in relation to the other. This was done so that the lenses could be brought close together.

Even with this arrangement, the inter-

*Produced by the writer.

axial was not ideal. It was fixed at 3¼ inches, although calculations showed that some scenes actually required as close as 1½ inch interaxials. But no such camera was available then, nor was there time to have one built. However, a complete set of matched lenses of different focal lengths effected a quite satisfactory compromise with the ideal.

'Stop-Motion' Photography

The greater part of the picture was a sort of phantasy, showing the parts comprising a Plymouth car dancing around and assembling themselves. Their movements were in synchronism with music and required the use of "stop motion" photography, that is, "one frame-at-a-time" shooting.

But a substantial part of the film contained "live action" shots taken in the foundry and shops and along the assembly line. The narrator for the film was Major Bowes of Amateur Hour fame. He appeared in "live action" in one sequence in which he spoke. This was the first "live action-live dialogue" shot ever made in a stereoscopic presentation. It created some difficult problems since the cameras would not fit into any available studio "blimps." However, the sequence was shot without any parasite camera noises being recorded.

Dual Projection Set-up

Since the Chrysler film was shot in a two-camera setup, and no special photographic and projection facilities for single-film handling was available, it was necessary to project with two projectors. A rather complex Selsyn motor drive was used for interlock, although a much simpler synchronization could have been attained by a straightforward mechanical linkage, such as we used for the

•
Rear view
 of the Norling
 camera, showing
 "racked-over"
 position for lining
 up a scene through
 the binocular
 view-finder.
 Camera contains
 built-in spirit level
 and footage
 counter.
 •



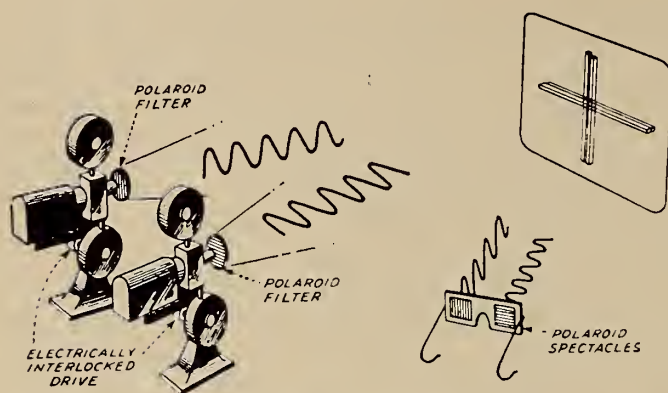

Diagram of a double projector installation using Polaroid filters on the projectors, plus viewing spectacles.

Pennsylvania Railroad's stereoscopic movie display at the Golden Gate International Exposition in San Francisco in 1940.

A Technicolor film, using the stop-motion technique was our next stereo production. A unique filter attachment was arranged in front of the camera lenses. The filters were mounted on wheels which rotated together. Color balance was attained by making sectors having angular dimensions calculated to pass the quantity of light required for each color and as demanded by the sensitivity of the film.

The "A" (red) filter passed light to which the film was more sensitive than that passed by the "B" (green) and "C5" (blue) filters. Consequently the red filter had the narrowest opening of all, and the "C5," to whose transmission the film was least sensitive, had the widest opening. The exposures were made by the alternate frame method of color separation. Three frames, one the red record, one the green, and one the blue, were made instead of one frame as in ordinary photography.

These separation negatives were used by Technicolor to make the printing matrices from which the dye imbibition prints were produced.

Two Separate Films Advocated

It has always been the writer's opinion that the stereoscopic camera for professional use should be built to take the images on two separate films. This is to afford the greatest flexibility in the studio and to permit the use of short focus lenses and to facilitate the making of optical effects in the duplicating processes.

One such camera was built. It contains the features deemed essential to a versatile camera. The most important are a variable interaxial and a convergence control, but important too is a binocular finder showing in miniature a three-dimensional view of the scene to be photographed. Visual inspection during focusing seems superior for stereoscopic work and focusing is easier when the view is seen in three dimensions.

The binocular view finder has an addi-

tional advantage: it enables the cameraman to compose the scene stereoscopically, using the interaxial and convergence controls, manipulating them until he gets the best possible arrangement. He can increase the interaxial if he wants to increase the apparent depth of the scene.

'Natural Vision,' Latest 3-D (?) Entry

HOLLYWOOD is currently excited by another seeming palliative for the drooping box-office—three-dimensional films, of all things. This latest wide-eyed wonder (of a temporary nature, of course) is the effusion of Natural Vision Corp. which, employing age-old technical knickknacks, comparatively speaking, promises to open up the road to the Promised Land. As reported, Natural Vision goes like this:

The only special equipment necessary to photograph a picture in the Natural Vision system includes a housing which holds two standard cameras facing each other. They receive their images from two mirrors mounted between their lenses in a V and separated by the normal distance between the human eyes.

The mirrors can be adjusted to angle so that the point of optical convergence will correspond to any focal point at which the cameras are set. Each camera takes a complete negative which may be used to produce standard two-dimensional prints for normal exhibition anywhere.

Special Viewing Aids

The three-dimensional effect require the use of two prints, one from each negative, two projectors *simultaneously*, and polarized spectacles for audiences. Transparent gelatins of opposite polarization immediately in front of each projector polarize the beams,

He can reduce it if nearby objects demand it.

The dual projector system used at the New York and San Francisco Fairs is substantially the same as that currently on exhibition at the Festival of Britain. According to press reports, it is also the same system which has recently been demonstrated by Natural Vision Corp. of Hollywood.

Dual Images on One Film

Systems for stereoscopic films using dual images side by side or one above the other have also been proposed. One of the problems in the two-image arrangement, whether in tandem or side by side, is the loss of light, because the light-covering circle covers a large area around the area occupied by the two images.

The ordinary circular light spot from the projector arc spills light all around

(Continued on page 28)

which are adjusted to proper convergence on the screen and the viewer equipped with corresponding glasses sees one image with one eye and the other image with the other eye. Consequently, he experiences normal depth perception. The system will work either in color or black-and-white.

Disadvantages of System

Its disadvantages are several. For continuous screening without interruption for rewinding, a theater must use *four* projectors instead of the standard two. The system will work only on a metallic-surfaced screen, and many theaters are equipped with porous screens, replacement of which would cost about \$200. And, finally, the exhibitor must buy spectacles for his patrons at a cost of five to ten cents a pair, and the patrons must be persuaded to wear them.

Nevertheless, says Natural Vision, the obstacles are by no means insuperable in big, first-run theaters, which normally have three projectors anyway. In situations where innovation is impractical, hopefully explains Natural Vision, a single print can be used to show the picture in the regular two-dimensional form.

Readers of IP will recognize in the foregoing much that is old-hat technologically, and this impression will be strengthened after a reading of the adjacent exposition by J. A. Norling.

Training British Projectionists

BASIC outlines of a program for training British projectionists, as agreed upon by the exhibitors (C.E.A.) and the union (N. A. T. K. E.) have been made available to IP through the courtesy of our good friend and colleague, R. Howard Cricks, editor of the technical section of the *Ideal Kinema* (London).

The plan will be administered by local committees of CEA and NATKE. All apprentices must be at least 16 years of age, and except with the approval of the local committee they must not be more than 17. Apprentices shall be indentured for four years, of which six months shall be considered a probationary period during which the indenture may be terminated by 14 days' notice on either side.

Deferment of military service will, it is hoped, be obtained for apprentices. They shall attend technical classes which, if held during working hours, shall be attended without loss of wages to the apprentice.

Successive Steps in Time

At the end of the indenture (four years) the apprentice shall take an examination which will qualify him as a projectionist. A further 12 months' experience will qualify him for another examination as a "second" (next highest rating), and after another 12 months he may take an examination as "chief" (top man in a projection room).

Provision is made for existing "chiefs" or "seconds" with the requisite experience to be issued certificates of competency without examination; while other projectionists over the age of 21, with more than six years experience, may take an examination for the certificate of a "second." The examinations will be administered by the Ministry of Education (governmental) and the British Kinematograph Society.

Mr. Cricks, having spent the World War II years in charge of training of about 1500 Army projectionists, has some very definite notions as to the curriculum and the locale and manner in which it is to be conducted. Excerpts from his published views are appended hereto:

Centers of Training

"First, a practical point: where are the training courses to be held? The obvious suggestion is at the numerous technical institutes which are to be found in all towns. It may be argued that classes could as well—or even better—be held in a vacant room at some theater, but in such a case the problem of instructors is intensified the while

a valuable attribute of the instruction will be lost—the scholastic atmosphere and technical and social amenities of the teaching institute. These, I urge, are points that must not be overlooked.

"As against the technical institute there is a strong argument: there is in such institutes a natural tendency for instruction to be scholastic in nature . . . which would be quite out of keeping with the present scheme. Even with youths whose educational background enables them to follow the accepted theoretical and mathematical approach to subjects, I have found a tendency to lose sight of the practical aspects in a fog of theory.

"Electricity, for instance, becomes not a living practical science but a mysterious natural obedience to obscure mathematical formulae. We must face the fact that the standard of education in our elementary schools just does not enable youths attending a class probably one half-day a week to cope with instruction of a type which may be very suitable for full-time students of matriculation standard.

Training Army Projectionists

"As an example, let me describe how we taught Army projectionists the rudiments of electricity—and remember that after six weeks of primary instruction and a further two weeks of practical tuition they were expected to become qualified projectionists, capable, under supervision, of putting over a show and of maintaining equipment. The majority of these men had had no prior experience of projection, and their standard of education varied from illiterates (quite literally we had several who had to be taught to read and write) to university students.

"We had a number of so-called meter boards made up. Each board carried a voltmeter and ammeter, open fuses, a d-p switch, a variable resistor, and terminals for attaching separate resistors, either in series or parallel. Half a dozen of these

R. H. Cricks in New British Post

R. Howard Cricks, many of whose extensive contributions to the technical literature on sound motion pictures have appeared in these pages, has resigned as technical adviser to the British Kinematographic Society and as editor of its *Journal* to become a director of Marsland Publications, Ltd., of London. This company specializes in technical books, catalogs, etc., for the photographic, movie and Tv industries.

Mr. Cricks will continue as editor of the technical section of *Ideal Kinema*, British film industry journal.

boards were fed from a battery of a dozen cells.

The first thing students were shown was how, when the terminals were shorted, the fuse blew. Next they were taught to read the meters and to notice roughly at what current the fuse blew, and also that the voltage was immaterial. Then they were given several fixed resistors of marked value which were connected up in series; a number of tests were made with different voltages and different resistance values, and from these tests many of the students derived Ohm's Law for themselves.

"Not until this stage was reached was the simplest mathematical treatment attempted. But from then on it was possible to tackle series and parallel calculations with the assurance that students really understood what they were doing.

Learning From Practice

"Since the majority of Army projectors, both 35- and 16-mm, used filament lamps, few of the students were taught anything about arc lamps. But those few classes who had to cover this subject learnt the theory of the arc from practical experience, and not *vice versa*. By means of meters they discovered how some of the volts were absorbed in the ballast and some in the arc, and saw how the proportion altered as the carbons were jammed together. Similarly, the principles of optics were taught by tracing the refraction of rays through prisms or half-lenses.

"This method of tuition is foreign to the normal technical institute. Yet I consider it essential that it should be adopted if youths are not to regard classes as dry-as-dust instruction, divorced from the realities of the projection room.

Selection of Subjects

"Next, what subjects are to be covered in the syllabuses of the three courses, the apprenticeship course, the second's course, and the chief's course?

"I am not contradicting what I have before said if I insist that mathematics must be an essential part of all these courses. The apprentice during his four years' training must progress far enough to have facility in the handling of decimals and fractions, and a smattering of the principles of algebra and geometry. The second should have a knowledge of logarithms and decibels. For the final course the embryo chief should find sufficient mathematical practice in his other studies.

"In electricity the apprentice must become familiar with D.C. calculations and touch upon A.C. and also learn the electrical aspects of sound reproduction. The following two years must include A.C. calculations and a survey of the principles of all the electrical equipment and wiring of the theater. Other subjects of

(Continued on page 27)

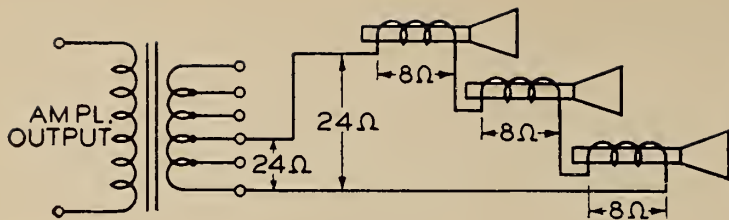

FIG. 1. When three 8-ohm loudspeakers are connected in series, the total impedance will match that of a 24-ohm tap.

The Matching of Loudspeakers

An excerpt from the book "Installation and Servicing of Low Power Public Address Systems," by John F. Rider, publisher, 480 Canal St., N. Y. City 13.

THE matching of one component to another in a public address system is very important. A bad match between a good amplifier and a loudspeaker will give poor results in terms of power output and fidelity.

Given an output tube having a stated plate circuit impedance, it is necessary that the loudspeaker voice-coil impedance match the impedance of the plate circuit. For the best possible fidelity, the source and load impedances should match within about 10%.

The impedance of a loudspeaker is the impedance of the voice coil and is always included in loudspeaker specifications. This impedance, which is equal to the voltage across the moving coil divided by the current through it, is given at a particular frequency, usually 400 cycles. Voice-coil impedances generally range from 2 to 15 ohms, with most between 6 and 8 ohms; however, in special loudspeakers it may be as much as 50 ohms.

Range of Impedances

When loudspeakers are directly connected in various types of series, parallel, or series-parallel combinations, the impedance offered by the total load may be anywhere from 0.1 ohm to 500 ohms in commercial practice.

Generally when the distance between the amplifier output transformer and the loudspeaker is about 200 feet or less, the line can be run at the impedance of the voice coil. The term "line impedance" as used here does not refer to any characteristic which the line itself has but means that the conductors are connected to a load of that type impedance. Thus, a low-impedance line means that the wires are connected to a low-impedance load. Any combination of loudspeakers can be connected by a low-impedance line.

Matching on Low-Impedance Lines

The total load impedance offered by two or more loudspeakers connected in series is the sum of their individual impedances. This total load can match the amplifier output by connecting it across the same value of tap impedances. Thus,

if three 8-ohm loudspeakers are series-connected, matching is secured by connecting the entire load across a 24-ohm tap on the output transformer as shown in Fig. 1.

The total load impedance offered by two or more loudspeakers connected in parallel, when all have the same voice-coil impedance, is equal to the impedance of any one loudspeaker divided by the number of loudspeakers. Thus, if four 8-ohm loudspeakers are connected in parallel, the total load impedance $Z_r = 8/4 = 2$ ohms. For proper matching, the loudspeakers should be parallel-connected to a 2-ohm tap on the output transformer as shown in Fig. 2.

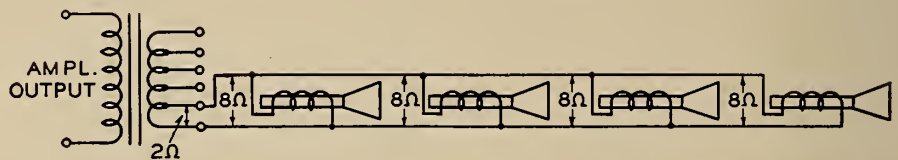

FIG. 2. Four 8-ohm loudspeakers connected in parallel will match the impedance of a 2-ohm tap.

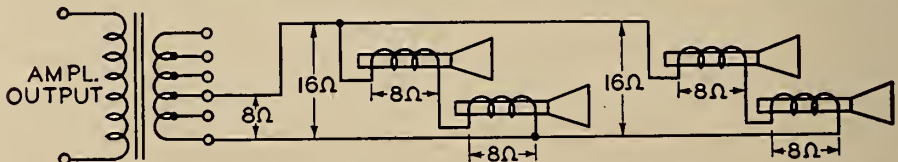

FIG. 3. When four 8-ohm loudspeakers are connected in two parallel branches of two series-connected loudspeakers each, the total load impedance will be 8 ohms.

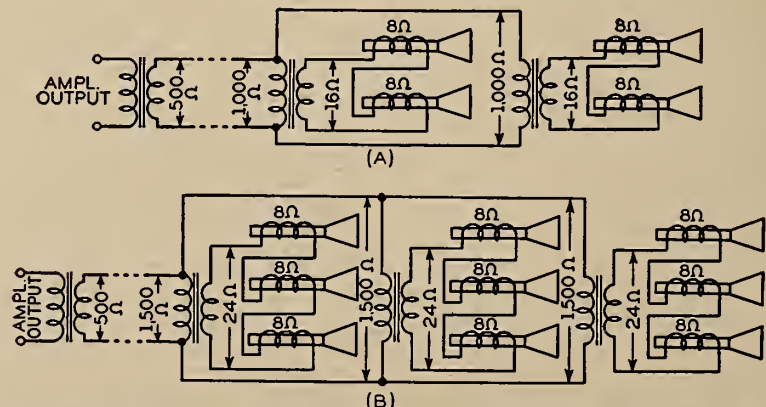

FIG. 4. Low-impedance loudspeakers can be connected to a high-impedance amplifier in many ways using line matching transformers. Parts (A) and (B) illustrate two such possible configurations.

The total load offered by four or more loudspeakers connected in series-parallel, when all have the same voice-coil impedance, is equal to the impedance of any series branch line, divided by the number of such series lines that are in parallel.

If four 8-ohm loudspeakers are series-parallel connected so that there are two loudspeakers connected in series in each branch and two branches in parallel, then the effective load is $16/2 = 8$ ohms. This load should be connected to an 8-ohm tap for proper matching, as shown in Fig. 3.

Matching on High-Impedance Lines

Where several loudspeakers are situated at some distance from the amplifier and from each other, then each loudspeaker (or group of loudspeakers) can be matched to a 500-ohm line (or other high impedance) by means of an individual transformer having a primary impedance such that in combination with the other individual transformer primary impedances the total load is 500 ohms (or equal to the amplifier tap impedance used).

Four loudspeakers in series-parallel using two matching transformers, or nine loudspeakers in three series-parallel groups using three matching transformers, can each be connected so as to

(Foot of Col. 1, Next Page)

Carbon Arc Copper Salvage

THE National Production Authority, charged with the conservation and allocation of critical materials essential to the defense program has announced (Aug. 2) a program for the salvaging of copper coating dripping from the carbon arcs used in practically all motion picture theaters in the United States. No mention was made of similar action by Canada.

The program involves the collection of the drippings by projectionists in every theater, studio, and exchange—in fact, wherever a carbon arc is in operation. The carriers who deliver film to the theater will collect the drippings and, without charge, turn them over to a “designated” theater equipment dealer in each film distributing city. The latter will periodically sell the drippings to an “authorized” metal scrap dealer.

Estimate 100,000 Pounds Salvage

It is estimated that approximately 100,000 pounds of copper can be salvaged annually by this program. NPA emphasizes that the success of this program may well insure the industry getting enough copper-coated carbons to maintain full operation.

Cooperating in the program are the following industry organizations: IATSE, film carriers in all territories, National Theater Supply Co., Allied States exhibitors group, Theater Owners of America, TESMA and TEDA (manufacturers and dealers associations, respectively); Motion Picture Assoc. (producers) and the Variety Clubs International.

All money collected from the sale of such drippings will be turned over to the Welfare Fund of the local Variety Club. The chairman of the Welfare Committee of each Variety Tent will assume the responsibility for supervising the operation of the program with the film delivery service and the equipment dealer in each film distributing territory.

Procedure for the various cooperating groups is outlined as follows:

Projectionists

Collects copper drippings from projector carbons in arc lamphouses.

Place copper drippings in container (avoid mixing stubs therein).

When container is filled, see that it is

picked up by film carrier to be delivered to “designated” theatre equipment dealer.

In film distributing cities, certain theatre owners may prefer to have filled container delivered to the theatre equipment dealer from whom he buys his projector carbons. There is no objection to this procedure.

Theater Owners, Managers

Cooperate with projectionists to collect copper drippings from projector carbons in suitable containers.

Either see that filled containers are given to film carrier for delivery to “designated” equipment dealer or deliver same to dealer from whom you buy projector carbons.

Film Carriers

Pick up containers filled with copper drippings from any theatre served by carrier.

Deliver container to “designated” theatre equipment dealer in film distributing city.

Dealers Not ‘Designated’

Where theatre owner delivers filled container of copper drippings to you, accept same and periodically deliver ac-

cumulated drippings to “designated” equipment dealer.

If such is not convenient or practicable, notify your Variety Club when you have accumulated 100 pounds or more of such drippings and he will assist in disposing of them.

‘Designated’ Equipment Dealer

Accept filled containers of copper drippings delivered to you by film carriers and theatre owners and other theatre equipment dealers.

When you have accumulated several hundred pounds of drippings (not less than 100 lbs.) notify the Variety Club.

Cooperate with Variety Club in disposing of copper drippings to authorized metal scrap dealer who will pay the Variety Club the most money for them.

During World War II a similar copper dripping salvage program was carried on. In some instances, however, difficulty was encountered because the copper drippings do not look like copper. They are black in color, due to the presence of small amounts of copper-oxide, although analysis shows the true copper content to be in the range of 94%. Scrap dealers hesitated to purchase copper salvaged by theatres for these reasons and also because the quantities offered seldom exceeded 50 pounds.

The full-scale publicity program now in progress is expected to iron out this and related shortcomings of the last campaign.

NPA Building Limit Lifted

The amended National Production Authority construction order, M-4A, lifts the limitation of \$5,000 on theater building costs, it was confirmed by NPA officials on Aug. 13. Under the amended order theater construction work can be started until Oct. 1 without any limit on the amount of materials used.

An application for a permit must be obtained after that date only if completion of a project will require the use of more than two tons of carbon steel, or 200 pounds of copper, or any quantity of aluminum alloy steel or stainless steel. There will be no limitation on the amount of other materials that can be used after Oct. 1.

An exhibitor can start a project before Oct. 1 no matter how much carbon steel, copper, aluminum alloy or stainless steel is called for provided those materials already are on hand. Applications for more than two tons of carbon steel, 200 pounds of copper or any quantity of aluminum alloy steel or stainless steel after Oct. 1 must be made on Form CMP-4C and Form NPAF-24A.

The opinion was voiced in equipment industry circles that the amended order will permit the construction of a large number of drive-in theaters providing the

limitations on metals listed in the order are not exceeded. 200 pounds of copper suffice a drive-in for 10,000 feet of underground cable, enough to take care of 600 cars.

4th Movie Tv Fight Telecast

Reaction to the fourth in a series of exclusive theater presentations of boxing attractions proved strong enough this time to warrant further offerings, based on a roundup of box office figures at the 15 theaters which carried the Joe Louis-Jimmy Bivins fight.

Fight, a routine affair in which Louis bested his opponent in slow methodical fashion, could not provide a fair yardstick of audience reaction. However, as a test of the public's willingness to come out to see a fight at a New York theater, the experiment proved a success. With the fight outside of the Metropolitan area for the first time, six local houses were permitted to telecast the fight: of these, four played to overflow crowds, despite a heavy downpour from 8 to 9:30 p.m.

Theaters experiencing the biggest siege at the box office were the Warner Theater in Times Square, and RKO's Fordham in the Bronx. At the latter, crowds were turned away after 8 o'clock.

MATCHING LOUDSPEAKERS

offer an impedance equal to that of the line. Fig. 4 illustrates line matching of the aforementioned series-parallel connected loudspeakers. It will be noticed that the matching transformer secondary impedance equals the load connected across it.

Now... RCA ready TO STAKE MORE MILLIONS in your Theatre Business

Offers this bold plan to help you modernize now on low-cost Credit Deal

Effective Immediately: For you, the theatre owners, RCA now makes available *additional millions of dollars* in new credit financing in an all-out effort to give you the theatre equipment you need to modernize right now for better house appeal, bigger grosses!

This offer to stake new millions in helping you modernize your theatres tells you in the most positive terms that RCA has boundless faith in the future of the theatre business.

Included in this great RCA Theatre Modernization Plan is virtually every item now carried by your RCA Dealer: projectors, lamps, power supplies, sound systems, screens, chairs, carpets, air conditioning. All the things you need right now to give your theatre greater house appeal for more pulling power. All available on early delivery. All yours on low-cost, long-term, easy RCA credit under this broad Modernization Plan.

Your own RCA Dealer has full details. He's all ready to work with you . . . to help you in every possible way to get what you need for modernizing your theatre immediately . . . to help you actually do something now about winning bigger box office with better house appeal.

You profit these 9 ways with new RCA Plan

1. You gain greater house appeal

This has already been proved by hundreds of recently modernized theatres that are outpulling less attractive houses. Equally important, your modernized theatre offers the increased entertainment value that could possibly command a higher admission price (more in line with today's higher operating costs).

Prove all this for yourself. Visit the nearest modernized theatre. Check the gate. See how much better than average a modern house can do. Then do likewise.

2. You are ready, come war or peace

If we do get into a major war, your modernized theatre is ready for the long, tough hours of operating . . . ready to serve again as morale builder for war workers. Ready with new equipment . . . precious equipment you may not be able to get in wartime.

If we just go on building defenses, your modernized theatre is

still getting its extra share of business through greater house appeal.

So you win either way if you modernize now.

3. You are ready for theatre TV

As theatre-TV develops, your house still needs good sound, screen, seats, carpet, and air conditioning. Theatre-TV can't change these basic needs. What's more, your house still needs good projectors and lamps. Because theatre-TV is an addition, not a successor, to movie film.

4. You improve your competitive position

By modernizing now, you take an important step to win and hold a bigger share of patrons, not only for the present, but for the years ahead. Only by offering better and better facilities to the public can you hope to improve (or even maintain) your position. So modernize now.

5. You get plenty of modernization under current NPA rules

NPA regulations are still liberal in allowing you to modernize your theatre. You can add or replace booth equipment, sound, screen, chairs, carpet, ductless air conditioning, and much miscellaneous equipment. And virtually all of these items are available under this helpful RCA Theatre Modernization Plan.

6. You let credit work for you

You get practically everything you need for modernizing your theatre, all for a modest cash outlay. Balance is on a long-term, low-cost contract set up to fit your requirements.

7. You save on today's equipment prices

You know that the defense effort and the threat of war may push

prices higher. So act now and save at today's prices.

8. You save on valuable tax deductions

If in your modernization program, you scrap any equipment or furnishings that aren't fully written off, you can deduct the undepreciated portion on your tax returns and gain an important saving. Ask your tax advisor.

9. You gain a million dollars worth of cheer

What's more important than getting a little joy out of your business? The kind that comes from operating a clean, attractive, modern theatre that's pulling in the patrons!

Give yourself a break. You only live once. Get up out of the doldrums. Get busy on housecleaning. Get happy. Go modern. You gross a million dollars worth of pride and self-satisfaction when you run a house that's ready to pull 'em in with greater house appeal.

Follow these 4 Simple Steps to modernize now

Step 1:

Look at your theatre *critically* (the way your patrons do). Make an actual list of items you need to bring it up to date: new projection and sound equipment, screen, chairs, carpet, air conditioning.

Step 2:

Call in your helpful RCA Dealer. Let him help. You'll find he can furnish you with virtually every item you need. All on early delivery. All on this broad, new RCA Modernization Plan.

Step 3:

Now get down to brass tacks. Find out how *little cash* it actually takes to get delivery on nearly everything you need to modernize your theatre right now. You'll find your RCA Dealer will *work with you* on this. He will try to work out the deal that is best for you.

Step 4:

Make the modest cash payment, take what you need and *get going*. Make a clean sweep. Perk up your projection, sound, screen. Reseat. Recarpet. Dress up your front. *Then bally-hoo it all over town*. And start reaping the quick rewards that modernization pays.

Pick up your phone . . .



Call your RCA Dealer . . . Get going now.

Why your credit is so good with RCA

You theatre owners have earned a lot of valuable credit here at RCA. Because you pay your bills.

In the past 22 years, you have bought many millions of dollars worth of RCA theatre equipment . . . *mostly on credit*. Your record for payment is almost perfect.

This is another good reason why RCA is willing to help you modernize with long-term, easy RCA credit. *You have earned this confidence*. So use this good credit to modernize now.

Are you competing for 1951 patrons with a 1936 Theatre?

Competition can be tough when your house is out of date. And most theatres haven't been modernized since 1936 . . . 15 years ago! They have fallen far behind in the parade of progress.

Remember: in business you never stand still. Either you move forward or you move backward.

So *now as never before* is the time to move forward again . . . to get up to date with a clean modern attractive hard-pulling house.

Modernization is so simple under this new RCA Plan.

You get greater house appeal for better grosses. You're ready, come war or peace or theatre TV. You improve your competitive position. You get plenty of modernization under NPA rules. You let credit work for you. You save on present prices and you save on tax deductions. And best of all, you gain a million dollars worth of "happier outlook on life" by modernizing now.

Don't delay another day. Call your helpful RCA Dealer and get started *right now!*

Offer May Be Limited . . . Act Now

Restrictions and shortages may curtail this RCA Theatre Modernization Plan at any time! So please do not delay. Call your RCA Dealer and reserve your share of this available equipment . . . now.

Get Full Story . . . Mail Coupon Today

Are you worried about the future of your Theatre Business?

These facts may give you new confidence.

RCA, more than any other company in America, knows the inter-relations of theatre business, theatre television, and home television. Because RCA pioneered in all three fields.

Armed with all this knowledge, RCA stands ready to pour more millions of dollars into the theatre business right now! Because when all the facts are known, the future of the theatre business still looks good.



THEATRE EQUIPMENT

RADIO CORPORATION of AMERICA

ENGINEERING PRODUCTS DEPARTMENT, CAMDEN, N. J.

In Canada: RCA VICTOR Company Limited, Montreal

Want More Information? For full story on this great new RCA Theatre Modernization Plan, just clip and mail coupon . . . *today.*

Theatre Equipment, Dept. 63T
RCA Engineering Products
Camden, N. J.

Without obligation, please give me full story on the broad, new RCA Theatre Modernization Plan which will make available my share of the additional millions of dollars in credit financing to help me modernize my theatre now.

Name _____

Position _____

Address _____

IN THE SPOTLIGHT



By
**HARRY
SHERMAN**

IN RECENT issues we have been giving tips on Social Security benefits, as culled from official sources. Although a booklet outlining these benefits in detail is available from the nearest SS office, requests for further data continue to arrive at our office. So here goes with what we think should be the final instalment of this series in this department.

Reference has been made to the terms "fully insured" and "currently insured." A fully insured person is one who has 40 "quarters of coverage." That is, if you have had SS earnings of at least \$50 a quarter in at least 40 calendar quarters (equivalent to 10 full years). A "calendar quarter" is any three-month period ending March 31, June 30, September 30, or December 31. These don't have to be consecutive.

Under the new amendments, a person also is fully insured if he has SS earnings in at least half of the calendar quarters between January 1, 1951, and the date he becomes 65. However, the minimum is six "quarters" of coverage.

A currently insured person is one who has at least six "quarters" of coverage during the 13-quarter period before reaching 65, or dying.

All benefits paid under SS, it can be seen, hinge on the primary insurance amount. In the 1950 amendments, a new and simpler method of figuring payments is provided, which may be used when you have had a year and a half of work under the law after 1950. Under it, if you average \$100 or less in monthly earnings after 1950, your own retirement payment will be half of your average wages. If you average from \$100 to \$300 a month (the maximum for insurance purposes), your payment will be between \$50 and \$80 each month.

The new formula is used by those who reach age 22 after 1950, and who have at least six quarters of coverage after 1950. Those who reach age 22 during 1950 or before, and who have at least six quarters of coverage after 1950, will use either the new formula or the old one, whichever gives the larger benefit. Those who don't have at least six quarters of coverage after 1950 must use the old formula

and the "conversion table" provided.

The new method calls for the averaging of monthly income (up to \$300 a month) taking 50% of the first \$100 and adding to it 15% of the remainder.

Suppose, on reaching 65 in January, 1955 your total wages from January, 1951, to December, 1954 (48 months) were \$11,040. Your monthly average would be \$230. Fifty percent of the first \$100 is \$50. Adding 15% of the remaining \$130 (\$19.50), your total old-age insurance will amount to \$69.50.

For more than 12 years your pay envelope was a penny on the dollar lighter. Commencing January 1, it was a penny-and-a-half lighter. From 1954 through 1959, there will be a 2% deduction; 1960-64, 2½%; 1965-69, 3%; 1970 and after, 3¼%. These deductions, matched by employer's contributions, go into the central fund out of which all payments are made.

• Several years ago projectionist Local 150 of Los Angeles sponsored legislation to amend the California State Labor Code so as to provide better ventilation in projection rooms. This legislation was adopted and is now a part of the State Labor Code. However, experience during the intervening years has shown that

when the wind blows in a certain direction, noxious gases still are blown back into the projection room.

Local 150 is moving to meet this situation by sponsoring a resolution to be presented to the forthcoming conventions of the California State Federation of Labor and the State Theatrical Federation.

Improved projection room ventilation has ever been one of the pet projects of this department, and we are glad to note the vigorous manner in which Local 150 is moving in this situation. So important do we regard such legislation for all IA Locals that we are publishing the Local 150 resolution in full. The resolution follows:

WHEREAS: the Labor Code of the State of California adequately provides for the number of cubic feet of air circulation in projection, rewind and generator rooms of moving picture theaters, and,

There is no provision in the State Code to insure that a back draft does not occur, thereby bringing the carbon monoxide back into the projection room, and,

It has been found upon investigation that the prevailing wind, if of great enough velocity and blowing in the direction of the exterior arc lamp exhaust stack, forms an impasse for the exhausted gases creating a

•
Reproduction of a sketch accompanying the recommendations of Los Angeles projectionist Local 150 for an improved means of exhausting noxious gases from projection rooms. Details of the hookup are given in the accompanying story.
•

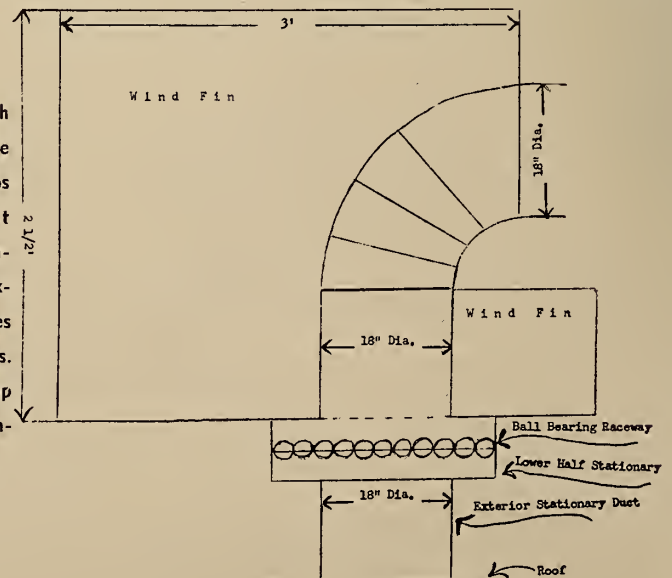

back-draft and bringing the fumes back into the projection room, and,

The installation of automatic funnels, or hoods, at the extremities of the exterior arc lamp exhaust stacks will prevent the return of carbon gases to the projection room. These devices are similar to the funnels used on shipboard to ventilate between decks. The funnels are L-shaped and finned so that the prevailing wind may rotate them 360 degrees. They should be mounted over on ball bearings to allow for ease in rotation: in this manner the funnel is turned away from the direction of the wind, making it impossible for a back-draft to occur. This is an inexpensive installation and would remedy the situation, and,

In drive-in theaters, in most instances, the exterior arc lamp exhaust stack, or duct, is too close to the projection room ventilation intake duct, with the result that the lamp-house exhausted gases are being drawn back into the projection room. The exhaust stacks, or ducts, should extend not less than 25 feet away from the projection room intake duct and be equipped with automatic directional exhaust hoods to correct; now

THEREFORE BE IT RESOLVED that Local 150, International Alliance of Theatrical Stage Employees and Moving Picture Machine Operators of the United States and Canada hereby requests that steps be taken to amend the State Labor Code to provide that directional exhaust hoods be installed on all exterior arc lamp exhaust stacks, or ducts, leading from projection rooms in moving picture theaters, and,

BE IT FURTHER RESOLVED that copies of this resolution be sent to the California State Theatrical Federation, The California State Federation of Labor and that they be requested to use their influence and power with the State Legislature in amending the State Labor Code to improve the ventilation in projection rooms in moving picture theaters as outlined in this resolution.

Respectfully submitted,

JOHN MAYNARD, President
CHAS. A. VENCILL, Secretary-Treasurer
GEO. J. SCHAFFER, Business Manager

• The sudden death of Bruce I. Steinmetz, 65, president for many years of Local 213, Great Falls, Mont., stunned his many friends in the Alliance. Steinmetz was elected last Spring secretary-treasurer of District No. 1, comprising the states of Montana, Idaho, Oregon, Washington and British Columbia, and for the past 19 years he served as president of the Cascade County Trades and Labor Assembly. During World War II he served as a panel member of the War Labor Board in his territory, and was a member of the City Post-War Planning Commission.

Steinmetz had an extensive acquaintanceship with the political leaders in his State, having taken active part in many labor bills inaugurated in Montana.

• If you have any old greeting cards, such as birthday, anniversary, Christmas, Mother's Day, Father's Day, get-well.



Bruce I. Steinmetz

etc., do not destroy them but send them on to Morris J. Rotker, 1258 College Ave., Bronx 56, N. Y., who turns them over to centers devoted to helping victims of cerebral palsy regain the use of their crippled muscles. These victims are taught to make many ingenious articles with these discarded cards, while at the same time they are exercising their withered limbs. An old-time member of New York Local 306, Rotker may always be counted upon to extend a helping hand to his less fortunate fellow-men.

• The 32nd biennial convention of the Theatrical Mutual Associations (TMA) was held at the Neil House, Columbus, Ohio, July 9 to 11, inclusive. The delegates were welcomed by representatives of Locals 12 and 386, both of Columbus. Much constructive legislation was adopted at the sessions, with particular attention

being paid to an organizing drive for new Lodges in the United States and in Canada. Special attention will be given to the latter area, with the next convention being set for Toronto.

William R. Noon, of New York Lodge 1, was re-elected Grand President, and Phil Hitter, of Long Island, N. Y., Lodge 67 was re-elected Grand Secretary-Treasurer.

The delegates reported that there is an increasing awareness throughout the theatrical crafts of the good work being done by all the TMA Lodges, which promises well for the expansion drive now under way.

• At a luncheon meeting at the Hollywood-Roosevelt Hotel last month with 75 officers and members of the Hollywood IA Locals, President Walsh pledged full support of the International to the Hollywood Locals in their forthcoming contract negotiations with the producers. Although actual negotiations will not begin until October 1 next, President Walsh urged the negotiating committees for the 16 Hollywood Locals to sift through all demands in order to determine those most important to the members as a whole. This, he pointed out, would help to keep major issues uppermost and reduce the danger that actual negotiations would be unduly prolonged, as they were in 1946.

Walsh stated that he planned to be present in Hollywood during the actual negotiations in order to see to it that "we get as much as possible and as quickly as possible from management." He pointed out that wages in the industry have fallen far behind the increased

GRAND LODGE OF THEATRICAL MUTUAL ASSOCIATIONS (TMA) IN 32nd BIENNIAL CONVENTION AT THE NEIL HOUSE, COLUMBUS, OHIO, JULY 9-11 LAST.



Front row (left to right): Robert Glasgow, 4th vice-pres. (Omaha Lodge 7); Phil Hitter, sec-treas. (Long Island, N. Y., 67); Luke Callahan, 1st vice-pres. (Cincinnati 33); Wm. R. Noon, grand pres. (New York 1); Nat Stein, past grand pres. (Chicago 4); Phil Lynch (Bronx, N. Y. 38); Irving Schlesinger (Lang Island, N. Y., 67); Frank Galluzza (Chicago 4)—all three on the laws and appeals committee;

Center row: George Postel, tiler (Cincinnati 33); Wm. R. Mull, 6th vice-pres. (New York 1); A. W. Fried, 5th vice-pres. (Brooklyn 30); Paul Stahl, 2nd vice-pres. (New York 1); S. Mazzucca, trustee (Chicago 4); M. Tarreano, trustee (Pittsburgh 37); H. Bluming, trustee (Brooklyn 30); B. Norton, trustee (Brooklyn 30); C. W. Rackwood, marshal (Toronto 11);

Back row: R. Hostetter, 7th vice-pres. (Hollywood 142); J. Mitchell, trustee (New York 1); J. A. Gallagher, 3rd vice-pres. (New York 1); S. Nicenhaltz, trustee (Brooklyn 30); J. Bauman, trustee (New York 1); E. Sullivan (New York 1).

cost-of-living, and that layoffs and unreasonable dismissals of old-timers from their jobs meant that a pension and welfare plan would have to be seriously considered by the producers.

- The members of Laboratory Technicians Local 702, New York City, won a 10% wage increase, retroactive to April 1, 1951. Should the Consumers' Price Index show a cost-of-living increase in April, 1952, the members of Local 702 will receive a further increase. This is in line with the General Motors plan for keeping wages in line with the cost-of-living. John Francavilla, president, headed the Local negotiating committee.

- We received a mixed reaction to the item that appeared in this department last month relative to the Health Insurance Plan (HIP) recently inaugurated by New York Local 306. Under this plan members are entitled to comprehensive medical care from doctors of their own choosing. Of course, like all new projects, HIP has its share of dissenters, some of whom are justified in their complaints, and others who are natural "kickers."

One letter we received stated that the writer was dissatisfied with his choice of doctor. He stated that although he made an appointment for a complete physical check-up, the doctor seemed rather disinterested and, after asking a few questions, gave him a perfunctory examination and suggested another appointment. When the man left the doctor's office he knew no more about the physical ailment which prompted his request for a checkup than he did when he entered it. In our opinion, the member, instead of griping about HIP to all who would listen to him, should have reported the incident to the proper Local officials and then selected another doctor.

From our own personal experience, we can say that the plan is an excellent one as far as it goes, and that as time goes on many of its present kinks will be ironed out.

- One of our old subscribers, Walter Dunkelberger, 1443 Fourth Avenue South, Fargo, N. Dak., is very anxious to obtain copies of the following back issues of IP: November 1948; March, August, September, October 1949; February, April, and October 1950. Walter needs these missing copies to complete his IP files and is willing to pay a reasonable price for them.

- A demand for a 50c-per-hour increase for the members of Local 348, Vancouver, B. C., is a subject for discussion in the negotiations between officials of the Local and the Odeon, Famous Players, and independent theaters. The present

scale ranges from \$2 to \$2.15 per hour, with drive-ins and downtown houses paying the top scale. As usual, the old exhibitor chestnut—the two-man shift—has come up in the discussions.

- George Weidemeyer, 56, member of Local 384, Hudson County, N. J., died several weeks ago after a short illness. Weidemeyer, a member of Local 384 for the past 36 years, was also a member of the 25-30 Club.

- *Recent out-of-town visitors to the offices of IP:* Bert Ryde, business representative, Local 233, Buffalo, N. Y.; Henry J. Benefield, executive board member, Local 568, Columbus, Ga.; J. Gibbons, recording-secretary, Local 182, Boston, Mass.; A. E. Bradshaw, Local 175, Tacoma, Wash.; Charley Hahn, J. E. McAuley Mfg. Co., and National Carbon's Bill Kunzmann.

Eidophore Tv With Color Set for Roxy, N. Y., Oct. 1

Theater Tv rights to the CBS color method for use in its Eidophore system purchased in February from Swiss interests were acquired recently by 20th-Fox. With the acquisition, 20th-Fox will employ the CBS system to bring color Tv to American theaters, with the initial demonstration of the system scheduled for Oct. 1 at the Roxy Theater, New York. It is planned to install the system in all 500 of the National Theaters chain (West Coast). System will also be made available to other theaters.

Ambitious Program Plans

Programming contemplated will be all-live and all-closed circuit, with no films to be used. CBS will not produce program material for the project. Preliminary plans look to the theater networking in color of Broadway plays, with "South Pacific" mentioned as a possible first. Sportswise, 20th-Fox plans colorcasts of top football games or outstanding boxing bouts.

An important phase of programming is expected to be the use of local events from various key cities, such as the aquashow, or top civic events around the country.

SMPTE Out of FCC Hearings; 'Primary Aims Accomplished'

In announcing that the SMPTE would not appear at the forthcoming (first week in December) F. C. C. hearings on theater Tv, the Society indicated that it is convinced that the matters under consideration at these hearings can be "adequately and informatively handled by the qualified engineering representatives of the

motion picture organizations there appearing.

"Present broad interest of the motion picture industry, as well as the constructive measures which the industry now proposes" are evidence that the Society's mission in the present preliminary stages of theater Tv development have been accomplished. The three primary functions of the Society on theater Tv were:

Primary Function of SMPTE

1. Coordinate the varied approaches of individuals and companies toward theater Tv.

2. Establish desirable performance objectives.

3. Arrange for free exchange of information on video band width, number of lines and suitable signal-to-noise ratios.

It was pointed out that the interests of the Society are technical rather than commercial and it does not seek channels for its own use. To avoid creating the impression that the Engineers, who have been active in this field for the greater part of a decade are now stepping aside, the Society has invited the FCC, eight industry organizations and all individual interests to call upon the Society at any time in a search for answers to particular technical questions.

Picture Co. Home Tv Surveys

The impact of home Tv on the movie theater box-office, the topic of numerous "surveys" which in the main disagree radically with one another, is now summed up in two versions by within-the-industry companies. As reported by the *Financial World* (Aug. 8):

"It is obvious that motion picture theater revenues are adversely affected by home installation of Tv sets although there is disagreement as to degree. The trade paper, *Variety*, quotes a Columbia Pictures source that for each 2% saturation of television sets in an area, movie box office receipts are reduced by 1%; while studies by Paramount Pictures conclude that for every 3% of Tv set saturation in an area, gross declines 1%.

The decline in box-office receipts this year from the comparatively television-free year of 1948 is estimated by Columbia at 9.4%. Business in non-Tv areas nevertheless is expected to be better this year. Box-office receipts in July picked up surprisingly in nearly all localities, which may mean that there has been some wearing off of the novelty of Tv."

Du Mont Tv Profits in Sharp Dip

Net profit of Allen B. Du Mont for the 24 weeks ended June 17 was \$109,000, with earnings equal to two cents per share after preferred dividends, compared with \$1.16 in the 1950 period.

Sales in the first 24 weeks of this year were \$25,612,000, compared with \$26,786,000.

New RCA Magnetic Recorder-Projector

A NEW 16-mm recorder-projector, providing the first means of directly recording commentary or musical background magnetically on the edge of 16-mm picture film, has been publicly demonstrated by RCA.

The new equipment for the first time makes available the special advantages of magnetic recording and reproduction in many applications of 16-mm film where allowable costs are restricted by the need for only a limited number of prints. It is of equal significance in applications demanding the opportunity for revision or variation of sound treatment without the cost and time involved in laboratory processing.

In addition to recording and reproducing magnetic sound, primary objectives in its development, the new equipment, designated the RCA "400" Magnetic Sound Projector, can also be used to reproduce optically recorded sound.

Recording, Playback, Erasure

Three main features of the equipment make it possible for non-professional users to obtain excellent results in magnetic recording: (1) To record, it is necessary only to turn a switch and talk or play music into a plug-in microphone. (2) After the recording is completed, another control may be set for immediate playback. (3) If revisions are needed or if re-recording of the film is desired, an electronic erase head may be activated by another simple control. A mechanical safeguard prevents accidental erasing.

Recording on the RCA "400" Magnetic Sound Projector requires no special preparation or studio facilities. The new method also eliminates the time normally consumed in waiting for processing of a photographic track.

A new film process has removed the last barrier to wide employment of magnetic recording on 16-mm film. A stripe of magnetic oxide one-tenth inch wide can now be coated on the edge of a 16-mm film economically. Moreover, the striping can be placed on the film either before or after it has been used for picture-taking and even if it already has an optical or photographic sound track.

80-to-7200-Cycle Range

RCA asserts that the new equipment achieves a new realism because it permits the recording and reproduction of sound over a frequency range of 80 to 7200 cycles and because background noise is virtually eliminated.

Hailed as the most significant advance in the 16-mm field since the introduction of synchronized sound, the new recording technique is expected to find many applications in films designed for industry,

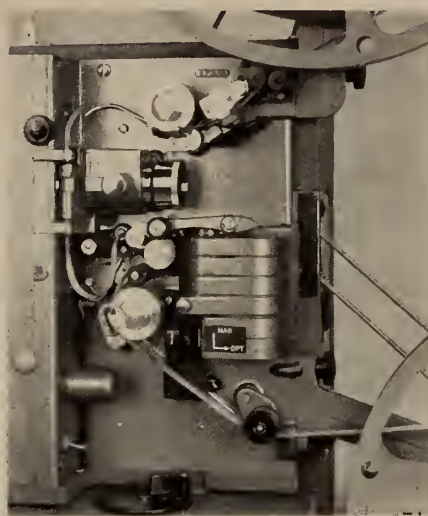

New RCA '400' magnetic 16-mm combination recorder-projector. Magnetic record-and-playback head and optical-reproduce head are both located behind sound drum, above and to the right of lower film sprocket.

schools, medical education, advertising, military and government agencies, and religious education.

For example, a narrative or commentary can be quickly applied to any previously made single-perforation film to which has been applied the magnetic track. The same picture can be presented with two or more different sound tracks, each suited to a particular application, location or type of audience. The preparation of a single subject in several different languages or dialects can be quickly and expertly accomplished.

The cost of recording a 400-foot reel of film with the new equipment has been estimated to be only about one-third of the cost of achieving comparable results photographically. In addition, film waste due to recording errors is eliminated.

Big Biz Mag Tells Us How

Hollywood can win substantial control of Tv if it is willing to risk its money. Fortune Magazine concludes in a survey of Tv in the August issue. Development, however, "may require extensive reorganizations and the disappearance of many of the Old Guard," magazine opines.

Article, titled "Tv's Time of Trouble," declares: "The big story about Tv today is no longer one of irresistible power. It lies rather in the unexpectedly strong bargaining position of Tv's competitors, heretofore given up for lost, and in the equally unexpected weaknesses of the new medium."

Fortune survey holds that the potentialities of video are so enormous that scarcely any limit on its ultimate size can be set. However, high costs, inherent day-

time weakness, and the difficulty of crossing time zones on national hookups are predicted as bringing many advertisers back to radio with its less expensive, around-the-clock programs.

"The theater owners, the only group in absolute competition with Tv are marked for slaughter," Fortune declares.

Theater Tv is found by Fortune to be "more a delaying tactic than a weapon, for though it can duplicate the coverage of Tv it has no defense against the home comforts of Phonevision." However, article points out, "The exhibitors cannot be jettisoned so long as theater distribution is the only way of financing the \$1-million average cost of a grade-A film.

New Order of Things Forecast

Discussing the reluctance of major studios to produce films for Tv, as the networks and independents prepare to fill in the gap, Fortune asserts: "It is clear that Tv's need for film will not be denied just because Hollywood's 'royal families' have barred the gates. As all elemental forces do under restraint, Tv will simply raise a new empire and crown its own kings."

RCA in Theater Tv Color Race

RCA will demonstrate at an early date its theater Tv system which will be "fully compatible" with the black-and-white RCA systems already installed. This indicates that only minor modifications will be necessary to permit full-color reception and reproduction.

In the meantime, it was said, RCA is co-operating with the Tv industry on the formulating of standards for a compatible system to go on the air, in keeping with the standards laid down by the Commission. It was emphasized that the FCC approved a standard, and not necessarily a system, leaving the door open for future acceptance of RCA, or any other color system. Such acceptance, said David Sarnoff, RCA board chairman, would not necessarily be to the exclusion of any other system already approved (CBS mechanical); in fact, Sarnoff declared, he's perfectly willing to meet the competition of any other systems which the FCC would approve side-by-side with the RCA's. "Not only willing, but anxious," he appended.

Tv Set Totals, Compatibility

Sarnoff estimated that there are 13,000,000 sets in operation at present in the U. S., and that there would probably be about 15,000,000 by the end of the year. The fact that these sets could not pick up any signal at all if CBS mechanical color system is the only licensed transmitter should militate against its general acceptance, whereas the RCA all-electronic color system is entirely compatible with present black-and-white receivers, he stressed.

Current IA-IP Amateur Radio Listing

CALL	NAME	LOCAL NO.	W5IIP	Pat Talbot—L. 249	W7GXN	Edwin McMurray—L. 180
W1BCE	C. J. Crowley—L. 459		W5DYV	Paul Belian—L. 604	W7IIJ	Donald Johnston—L. 401
W1EBO	Woodrow Guile—L. 459		W5CQ	Ray J. Morrow—L. 597	W7AVM	J. Elmer Newell—L. 429
W1LW	Norman Soules—L. 459		W5CQQ	Rajmunt J. Machu—L. 597	W7JTM	J. Allen Evans—L. 294
WINZE	Arthur Madsen—L. 182		W5IMT	A. S. Johnstone—L. 293	W7OAS	George Olson—L. 294
W1BHJ	Otto Halquist—L. 182		W5ODA	Bill Couse—L. 450	W7KMO	James A. Furr—L. 294
W1WI	Tom McNamara—L. 505		W5OQJ	Norman Olstad—L. 279	W7FTV	Lloyd J. Hagaman—L. 240
W1BVB	Don Fancher—L. 439		W5ODA	William Couse—L.450		
W1IYY	Harold Wyman—L. 96		W6BAA	Amos Kanaga—L. 409	W8VDP	Jack Harwood—L. 160
W1JBU	George Gravell—L. 96		W6UZA	Malcomb Keele—L. 150	W8BYT	L. Grazier—L. 388
W1BTW	J. Roland Lizotte—L. 546		W6DPU	Roy Brann—L. 150	W8NS	Carl Bacon—L. 199
W1JWN	Theodore Kahn—L. 86		W6PFF	Frank Champlin—L. 150	W8WSL	Denzel Murphy—L. 239
W1KKJ	Howard Bruya—L. 505		W6PQS	Joe Wilson—L. 504	W8OWK	Edw. Miller—L. 199
			W6ALO	Tom Jentges—L. 504	W8EEW	Muriel Murtagh—L. 291
W2TSN	Victor Bufis—L. 365		W6GTP	E. Schwartz—L. 695	W8QIX	F. W. McDonald—L. 199
W2WZX	Erich Pattky—L. 244		W6MTO	Leroy Wardel—L. 762	W8QFK	Jim Robinson—L. 64
W2CYQ	Frank Larham—L. 108		W6DYJ	Ed Pothier—L. 215	W8BWU	James T. Smith—L. 100
W2ARP	Fred Ramhorst—L. 534		W6IV	Delos Trim—L. 297	W8CHI	C. W. Salchli—L. 315
W2NFU	Sydney Trisch—L. 306		W6PB	Dan O'Brien—L. 159		
W2RUA	Hugh Newcomb—L. 462		W6RKB	Bob Gillespie—L. 241	W9NLP	Rolly Long—L. 110
W2QYQ	Alfred Beckett—L. 462		W6YWC	Lewis Howard—L. 162	W9OL	W. P. Atchison—L. 323
W2VSQ	Frank Tamborel—L. 306		W6EFL	A. H. Whitney—L. 150	W9NPG	John Bain—L. 323
W2OCL	Edward Ricca—L. 306		W6EAQ	E. L. Kline—L. 150	W9LBL	R. B. Connelly—L. 110
W2MYI	Mike Revzin—L. 306		W6CAG	August De Grazia—L. 150	W9EDW	Harold Nelson—L. 221
W2ORS	Charles Roop—L.418		W6CYW	Frank Hemerlein—L. 150	W9RTA	Herb Kleinbeck, Sr.—L. 110
W2DZA	Alex Knight—L. 353		W6KNI	Cliff Schwander—L. 150	W9FOL	Merrill Smith—L. 110
W2AOM	Jack Garritson—L. 306		W6REH	Harry Gould—L. 150	W9AZA	Kenneth Mass—L. 721
W2NAJ	Peter Hurgon—L. 306		W6BPT	Roy Pinkham—L. 431	W9GQD	Clarence Hawkins—L. 263
W2AMB	Fred Huff—L. 306		W6FBW	Frank Amarantes—L. 431	W9DBY	Kenneth G. Alley—L. 421
W2ZCE	John V. Richards—L. 1		W6WPG	Robert Hyde—L. 796	W9VNV	Charles Mitten—L. 194
(formerly W3JAX)			W6IDY	Dom Lucido—L. 241		
W2RQZ	Frank Lipinske—L. 337		W6EP	Leslie Hewitt—L. 695	W0VGC	H. F. Heckel—L. 230
W2HRJ	Charles Beckett—L. 462		W6HK	Frank Creswell—L. 728	W0ZIM	M. Geiskiang—L. 230
W2BOR	William Axton—L. 524		W6YDU	C. R. Putnam—L. 490	W0GSW	James E. Evans—L. 242
W2HWF	Albert Dietrich—L. 306		W6BWI	Harry Morse—L. 297	W0JKU	John Cresap—L. 242
W2BDK	Lloyd Matteson—L. 290		W6VTX	Ralph Addy—L. 521	W0UOP	Clair Rockholz—L. 286
W2PVB	Kenneth H. Allfrey—L. 290		W6EIR	Leroy Ward—L. 521	W0WSH	Herschell Allredge—L. 443
W2HP	Jack North—L. 640		W6ZOK	Max Miller—L. 521	W0DOL	E. M. Karcher—L. 482
			W6FGV	Norman Owens—L. 521	W0SJK	O. S. Keay—L. 219
W3KNY	Harris Good—L. 661		W6BEP	C. C. Applegate—L. 187	W0SLV	Walker Faussett—L. 395
W3MEY	Leo Foran—L. 335		W6WPG	Robert Hyde—L. 796	W0BTT	R. R. Kerwood—L. 586
W3BBV	Nelson Stover—L. 283		W6ZEN	Floyd McPherson—L. 709	W0WHV	Max Hollingsworth—L. 465
W3JMA	Ralph Rushworth—L. 181		W6FOP	George Abrams—L. 297	W0BVO	Paul Hnnter—L. 191
W3PMY	John Nordine—L. 296		W6AGN	Arthur Hansen—L. 297	W0QI	E. D. Van Duyne—L. 191
W3MHE	Charles Gibson—L. 444		W6EWU	Tom Wells—L. 297	W0BSO	Don C. Atherton—L. 191
W3BJ	Al Edwards—L. 307		W6YBC	Hansen Cresap—L. 297	W0GFN	Ira Hasket—L. 491
W3RXT	Bernard Rask—L. 171		W6ZBX	George Kiaser—L. 297		
W3TVM	Harry Drew—L. 171		W6CZK	Ray Baumann—L. 434	CANADA:	
			W6CML	Tom Moore—L. 169	VE3ABV	Jack Snider—L. 173
W4BWN	Bob Cobble—L. 405		W6IYT	L. H. King—L. 796	VE3BAK	F. Winkle—L. 173
W4HJC	Arlie Belflower—L. 225		K6CH	H. H. Quackenbush—L. 510	VE3BVC	E. H. Whyat—L. 173
W4MCT	Jim Davis—L. 552		W6GCF	Charles Busby—L. 599	VE3BWC	Lou Lodge—L. 173
W4NOM	Buddy Rogers—L. 225		W6HUE	Homer Elias—L. 599	VE3BOG	M. Winslow—L. 461
W4PKT	M. H. Sanders—L. 507		W6UVO	Edward Ives—L. 150	VE3CF	H. Horner—L. 173
W4CIU	Bill Britton—L. 537		W6WER	Clarence Woerth—L. 150	VE3TE	Tom Burrows—L. 173
W4FGG	Marvin Storler—L. 144		W6RN	Lynn Bradshaw—L. 162	VE3APR	Harry McClelland—L. 582
W4RFF	Howard Ross—L. 574				VE5JK	Jack Kyle—L. 295
W4RMT	E. M. Karcher—L. 482		W7LAT	Fred Jones—L. 720	VE7OT	M. Thoreau—L. 348
W4KBJ	James File—L. 290		W7PEC	Jim Harford—L. 720	VE7US	C. Moorehouse—L. 348
W4MEP	J. Wyatt—L. 793		W7AXY	John Murphy—L. 91	VE7MN	C. H. Richards—L. 348
W4FGK	D. Holye Knight—L. 412		W7ALM	Chester Lamont—L. 446	VE3AYQ	Cecil D. O'Neill—L. 461
W4DPT	Adrian McCroskey—L. 446		W7FJZ	Z. A. Sax—L. 159	VE5RJ	Ron Marchant—L. 300
			W7HE	Dee Hart—L. 91	VE3AHJ	Walt Mann—L. 467
			W7HPF	John Gilbert—L. 91	VE7ALW	Merle Wilson—L. 348
					VE7APN	Jack Stone—L. 348
					VE7APU	Tom Hepple—L. 348
					VE7BJ	Edward S. Brooks—L. 348
					VE7ACB	F. J. McGuire—L. 680

[NOTE: Additions and corrections should be sent to AMOS R. KANAGA (W6BAA), 262 La Casa Ave., San Mateo, Calif.]

Tv Viewing Difficulty Corrected by B. & L.'s Tele-Ban

By BAUSCH & LOMB OPTICAL COMPANY

NOT so long ago ophthalmologists and optometrists began to notice that an increasing number of patients complained of "difficulty" in viewing television. The severity of this trouble, as reported, ranged anywhere from a sensation of tiredness after several hours of viewing to an inability to tolerate more than a few minutes of watching.

Examinations revealed that many needed corrective lenses. Many others, however, were already adequately corrected or did not require prescription changes. These latter patients posed a new problem. A specific solution, to be prescribed for patient relief, remained to be determined.

Sense and Nonsense

Some professional people arranged Tv-set experiments at home to ferret out the probable cause of their patients' complaints. Various tinted lenses were tested, including several sunglass types. Rules for Tv viewers to follow appeared in papers and periodicals, along with news stories about Tv. Some of the printed material was sound, and some was ridiculous.

Soon we began to receive inquiries as to what we might offer as an answer to the dilemma. Our answer is the new television glass, Tele-Ban, developed specifically for relief of discomfort in Tv viewing, and for giving the wearer crisp, sharp pictures.

X- and Gamma Ray Tests

It should be understood, at the outset, that Tv is not dangerous to the eyes. There are no X- and gamma-ray radiations evident when tested, over a 40-hour period, with health film in contact with the kinescope tube face, and with voltages up to 12 Kv. Discomfort, rather, is compounded of several factors including (a) the energy distribution of the source, (b) too short an observation distance, (c) lack of surround illumination, (d) the chromatic aberration of the eye.

One might look at the energy distribution of the kinescope tube, see its similarity to the energy distribution of a daylight fluorescent lamp, and conclude that no cause for investigation existed. But this would not take into account the fact that the daylight lamp illuminates what we see by reflected (and therefore altered) light, whereas we view the kinescope tube directly.

As far back as 1888, Konig and Brodhun studied brightness discrimination at scotopic levels (adjusted to see in a dark environment), and demonstrated higher sensitivity for short-wave light. Crozier and Holway, in 1939,

studied brightness discrimination at photopic levels (adjusted to see in a bright environment), in several sizes of test field, with chromatic illuminations, and from their data one can extract the information that sensitivity is highest in the blue, with green and white second, and red the lowest.

The separation for sensitivity levels for blue, green and red is substantial. Hence, the kinescope tube high level of energy at about 440m μ (blue) is important, after all. It is responsible for the high energy level in the area where the brightness sensitivity of the eye is greatest.

IA-IP Radio Hams Constitute Theater Tv Talent Backlog

By AMOS KANAGA (W6BAA)

Sec. L. 419, San Mateo, Calif.

Activity on the ham bands has been at an all-time low except for the 75-meter phone band which still sparks out with the midnight wisecracks from the boys down South and up around Montana. We often wonder if that years'-old checker game of two IA guys who are well known to the hams will ever be wound up, to the intense disappointment of the dozens of BCL listeners who kibitz right along with them.

Becoming ever more popular with the boys is 75 and 10 mobile. Could this be the reason why a lot of fellows are leaving for work earlier than usual?

Of great importance, we think, to radio hams everywhere is the announcement by President Walsh of the IA's intention of doing a thorough organizing job on the Tv field. For our part, we do not know of a gang more qualified for Tv work than are the radio hams—those technically-qualified men from the IA-IP amateur radio list.

Nice Backlog of Tv Talent

Most certainly there is experience in the electronic field on that list that, with just a little more schooling, could be used to the great advantage of the craft. Perhaps we could profit by going back over those issues of IP which presented basic data on Tv. After all, the fundamentals of Tv remain pretty much the same, and I doubt whether anybody knowing these fundamentals would have any great trouble in handling any form of theater Tv.

Many thanks to the boys for their many nice letters, and we do try to answer all of them. Keep the suggestions coming. An up-to-date list of IA-IP hams appears in this issue. 73.

Viewing Distance Important

Too many Tv viewers feel that they see the picture better if they hug the screen—one to six feet away. When at an observation distance of about five feet, the short-wave light (blue) and long-wave light (red) are about equally out of focus (because of chromatic aberration), with energy in the blue predominating. (At greater distances the blue is more out of focus.) This fact is recognized and is commonly used in the theater to create a soft, out-of-focus effect by illuminating the scene with blue spotlights. Hence, again, the excess energy in the short-wave portion of the visible spectrum is a source of difficulty.

It does not take much imagination, at this point, to guess that a reduction in the energy in the short-wave part of the spectrum should effectively halt complaint. But, how to do it? Available filters either do not absorb enough, in the right places, or absorb too much. Those that absorb too little do not do the job. Filters that absorb too much, such as Kalichrome C, are harsh; they distort colors, and are worthless for colored Tv. The criterion—absorption of the proper amount of blue with minimum absorption elsewhere—had to be met by a new filter.

After several months of fruitless work with colored glass with proper optical characteristics and additional time spent on coated lenses the solution, in Tele-Ban, was found. Tele-Ban lenses are coated. They are stable. The coating is permanent and as hard as the glass itself. Semi-finished Tele-Ban lenses can be finished in the prescription shop, with no more than normal precaution against scratching.

Tele-Ban is unique and is unlike other selective absorptive lenses. It is designed specifically for the job. Tele-Ban assures comfortable Tv viewing.

The effectiveness of Tele-Bans has been amply demonstrated by field tests and by an intensive user survey. Reports have been enthusiastic: Tele-Bans definitely make Tv viewing more comfortable. When people complain about difficulties in viewing Tv, apart from those produced by ametropia (erroneous refraction of the eye, causing imperfect vision), one can be sure of obtaining relief by the use of Tele-Bans. They will be available generally later this year.

Seager in Ansco Sales Post

CHARLES W. SEAGER has been named Eastern Manager of Ansco's professional motion picture sales department, with headquarters in the Chrysler Building, N. Y. City. Seager joined Ansco in 1946, following an extended tour of duty as a Major in the U. S. Signal Corps during World War II. Previously he had been identified with the visual education field.

Networks' Vested (?) Rights in Tv

Stockholders of both companies have approved the merger of American Broadcasting Co. with United Paramount Theaters, in which the latter would exercise dominant control. Next step is to get the approval of the FCC.

Meanwhile, a self-appointed body of people, "acting in the public interest," announced that it would oppose not only the ABC-UP merger but *all* exclusive theater Tv. "Subscription radio was never approved by the FCC," says the Fair Television Practices Committee, heavily weighted as to membership, of course, by lawyers. "No precedent of any kind exists for granting to theater Tv exclusive use of any publicly-owned channels."

FTPC charged that efforts are being made to stamper the motion picture industry into Tv despite doubtful legality, lack of technical proof on ultra high frequencies, and absence of evidence of economic value.

QUERY: Do the Tv networks operate on "publicly-owned" channels for free? Sure, except that the advertiser picks up the gigantic tab the proceeds from which go into network tills, not to any philanthropic enterprise. Moreover, the cost of the Tv network program is figured into the retail (we mean consumer) price of the commodity advertised.—ED.

Kodak 16-mm Multi-Speaker

Eastman Kodak has developed a new multi-speaker unit for use with the regular speaker of its Pageant 16-mm sound-film projector. These four widely separated speakers permit considerably greater flexibility in sound reproduction, making it unnecessary for the projectionist to raise the sound volume to such high levels as to impair fidelity.

Each of the speakers in the new unit is an 8-inch speaker mounted in individual baffles. One is supplied with a 35-foot cord; two with 45-foot cords. Assembled together, the three speakers form a convenient carrying case. The complete unit weighs only 17 pounds, and will enclose a 2000-foot reel.

The speakers are equipped with connectors which make it easy to arrange them in the correct electrical hook-up.

Major Company Color Upswing

Another cheering note in the seeming resurgence of motion pictures as the prime source of family entertainment was sounded with the Metro announcement that more than half of its output for the next 12 months will be in Technicolor—color being one of the more important facets of the triumvirate of color, stereophonic sound and three-dimensional pictures which, informed sources hold, will contribute materially to the box-of-

fice upswing within the next few years.

RKO, meanwhile, has announced that only 12 of its projected 36 features for the coming year will be in color. This percentage is generally regarded as somewhat low for a so-called major company. Of the next 15 releases from Fox within the next four months, only 4 will be in color.

Theater-Nets Tv War Opens

Indicating a continuous battle between theater Tv interest and the Tv networks for the rights to large-scale sports events, Du Mont has named Tom Gallery to head a new sports department whose special—nay, sole—function will be to sign and sell major sports events. Gallery has a background of promoting big-time sports events and, significantly, was moved to his present spot from that of network sales director.

U. S. 'Essential' Job Classification

"Prospects for the motion picture industry or any substantial number of its job classifications being catalogued as "essential industry" are extremely slight.

Cleaning Projector Lens

For the benefit of those who may have been misled by the nonsense that has appeared lately in the non-technical press, IP offers here a few basic tips anent the proper care of a projection lens, coated or uncoated, as supplied by Kollmorgen Optical Co.:

1. Remove lens from projector at least once a day for cleaning.

2. Remove all particles of dust or lint with a *clean* camel's hair brush, which should be used only for this purpose.

3. Wet sheet of clean "Lens Tissue" in any good liquid lens cleaner similar to the "Guild Craft" lens cleaner, grain alcohol or acetone, and wipe the surfaces gently but thoroughly.

4. Cloths of any character are not recommended for cleaning—use *Lens Tissue*.

5. Dry the surface with a clean dry piece of "Lens Tissue."

6. Never attempt to open Super or Series II Snaplites since they are factory-sealed to eliminate oil seepage.

TYPICAL PROJECTION ROOM IN HOLLAND

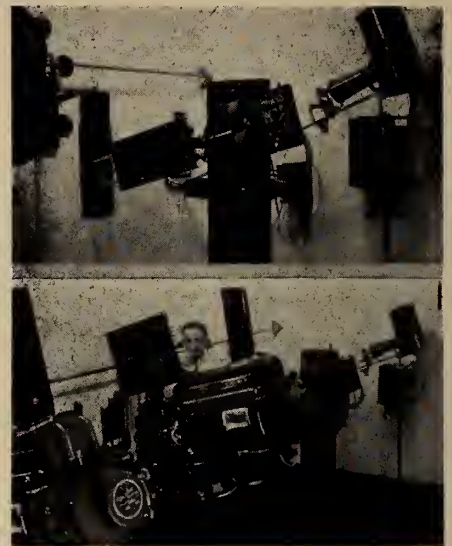

Slide projector (top), which utilizes a mercury vapor light source. Over-all room view (bottom).

it was suggested bluntly at the U. S. Dept. of Commerce, whose spokesman pointed out that only works immediately associated with industrial production are regarded essential today.

Letters to the Editor

To the Editor of IP:

Manufacturers of Class A and Class B Products (motion picture equipment is Class B), using over a minimum quantity of controlled materials (steel, copper, and aluminum) apply to the National Production Authority for material allocation and DO-Rating to facilitate the purchase of materials in short supply.

The NPA after a study of the request, allocates to the manufacturer certain weights of these materials.

Though Motiograph's request for material allocations for sound and projection equipment was based on a lower than normal production schedule, the NPA allocated for its 4th quarter operation approximately 50% of the materials requested.

If other theatre equipment manufacturers' allotments were similarly low, as there is good reason to believe, then it is certain that equipment is to become scarce by year end. Right now most theatre equipment is in good supply, so it is advisable for the theatre owner to buy now while equipment can be obtained on reasonably good delivery terms.

FRED C. MATTHEWS
Vice-President, Motiograph, Inc.

To the Editor of IP:

Many of my colleagues, no less than I, enjoy your publication very much. We all
(Continued on page 28)

BRITISH TRAINING

(Continued from page 15)

a theoretical nature must include optics, photometry, sound and acoustics and—a most important topic—regulations.

Projectors, Soundheads

"The practical side is at least as important as the theoretical. Every training centre must be equipped with a variety of old projectors and sound-heads, which the students must dismantle and reassemble, in order to become conversant with the mechanical principles of projection.

"Film handling is a subject that should not be left for instruction in the rewind room; one still sees projectionists making joins in the time-honoured manner of applying the cement, then holding the two ends of the film in mid-air to register the perforations—a method that simply cannot be used with safety base.

"An important aspect that throughout the course must be kept to the fore is showmanship. However good a technician a man may be, he will never make a good projectionist without that touch of showmanship in his make-up. Stage technique must also be touched upon.

Training for the 'Seconds'

"The training for the second projectionist's certificate will be a continuation of the previous training. But the training for the chief should be regarded in a rather different light. Technically, the second should have the same knowledge as the chief, since on the chief's days off he will be in charge. But the chief must be trained to accept responsibility, to offer technical advice to his boss, and to become a prominent figure in the running of his theater. Much of the last year of training should therefore be devoted to consideration of present problems—picture brightness, auditorium lighting, sound quality—and possible future developments—stereoscopy, stereophony, television.

Qualified Teaching Staff

"It may be thought that this syllabus is too ambitious. Certainly it introduces a pressing problem: where are the instructors to be found?

"For the more theoretical subjects — mathematics, electricity, optics — the services of existing technical teachers are virtually necessary. There is far more in teaching than just knowing one's subject—as I learnt during my war-time experience. But I repeat, these teachers, must be prevailed upon to give instruction in an essentially practical manner.

"Unfortunately, few institutes will boast instructors capable of teaching the more practical subjects, such as projection principles, sound-on-film reproduction,

film handling, showmanship. For instructors in such subjects we must turn to the industry: projectionists, theatre engineers, equipment engineers, and salesmen. But first, I emphasize, they must be given a course of instruction in the actual job of teaching.

Small-Town Applicants

"Everything I have written previously can apply only to the apprentices and projectionists working in theaters in and around the larger towns. What of the many projectionists in country shows, too far from the nearest town, where the in-

auguration of training classes for two or three projectionists is quite out of the question?

"The only practical answer to give such men a fair deal is the correspondence course. Provision should be made for such courses to be available without charge to the country apprentice. The apprentice should be allowed the appropriate time from his duties to study the course, and, if possible, a room should be made available to him in the theater."

[ED.'s NOTE: Comment on the foregoing is contained in the Monthly Chat column beginning on page 3 of this issue.]

Give the HEART of your theatre a "Break" ... or it may ~~BREAK~~ your box-office

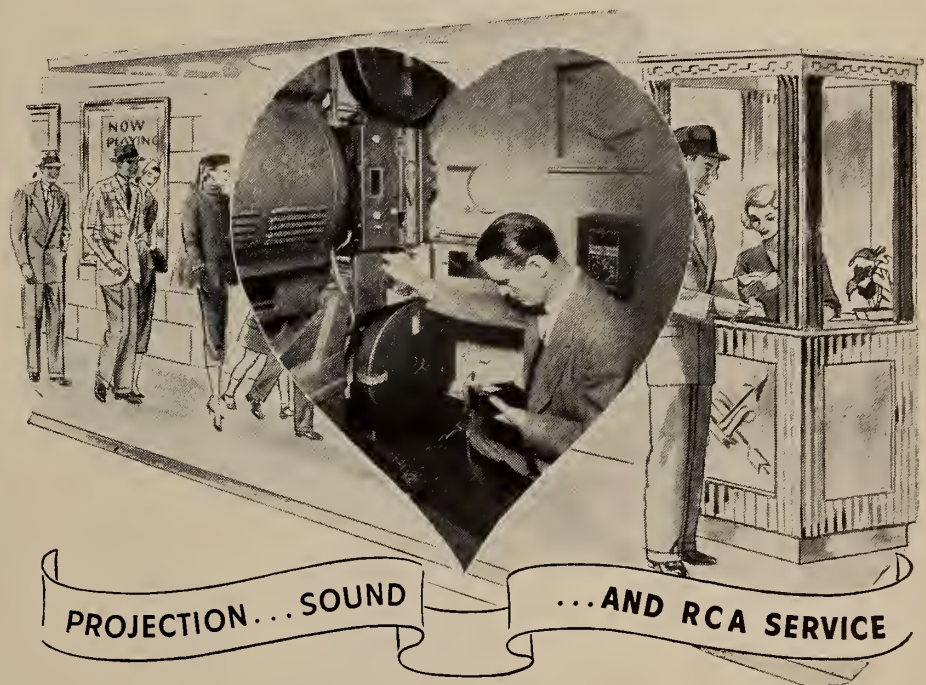

SCHEDULED INSPECTION check-ups and regular maintenance are more than a "break" for your projection room equipment—the heart of your theatre. They are performance security that assure high-quality showmanship for your movie presentations.

Neglect of proper maintenance control results in equipment troubles that seriously interfere with box-office takes.

It costs so little to protect so much

The advantages of RCA Service are yours at a cost so low, a few admissions daily pay for it. Write for complete information.



Protect your equipment with RCA service —Constant usage of sound and projection equipment causes wear and tear of critical parts . . . tubes become weak . . . transformers and condensers need to be replaced . . . wiring must be checked. The possible scarcity of new sound and projection equipment . . . even replacement parts . . . makes it important that you protect the life of the equipment you now have.

RCA Parts Plans cover all makes and types of theatre sound equipment, as well as projectors and accessory units. This protection is more vital today than ever before.



RCA SERVICE COMPANY, INC.

A RADIO CORPORATION of AMERICA SUBSIDIARY
CAMDEN, NEW JERSEY

Letters to the Editor

wish that we could see the many wonderful technical developments in America. Each month's issue of IP is eagerly awaited by all of us.

A. ZEHNGEBOTH
Zlil Cinema, Haifa, Israel

New 'Fluid Sound' Phone Pickup

Utilizing the principles of fluid-damping and fluid-coupling, the Fluid Sound Phono

Pickup has been introduced by Lindberg Instrument Co., 830 Folger Ave., Berkeley 10, Calif. It consists, essentially, of an actuating arm to which a sapphire-pointed stylus is affixed; a pastic body containing three cells filled with an electrolytic, non-toxic, conducting fluid, and a rubber diaphragm.

In operation, D.C. flows through the three cells in series and is modulated by the record track oscillations (acting through the stylus). The current modulations thus produced cause an output voltage to appear on the center cell electrode. This voltage is then fed in the usual manner to any audio amplifier.

Needle-record contact is used only to modulate the externally supplied D.C. voltage as it flows through the fluid.

The same basic Fluid Sound cartridge is used for all disc-recorded sound reproduction, but three different points are available to accommodate variations in groove-width. Each point-size is mounted in a cartridge of distinctive color to insure quick and positive identification.

STEREOSCOPIC FILMS

(Continued from page 14)

the images. This condition can be improved upon by a light condensing system having a cylindrical lens element. Then the light spot becomes oval instead of round.

The Newcomer Anamorphoser

Another method is to introduce an optical device on the camera to compress the images in one direction, and a similar device on the projector to expand them back to normal proportions. Such an optical device is called an "anamorphoser." Several types have been constructed, but it remained for Dr. H. Sidney Newcomer to design one that does not introduce serious aberrations and have other optical handicaps. The Newcomer Anamorphoser is capable of effecting a compression of the image to almost 2/3 and an expansion of about 1½ times.

Among the methods suggested for the employment of a single film to carry the two images is the "beam-splitter" in one form or another. The device has two pairs of mirrors placed in front of the lens and arranged so that the pair on the left will cause the left-eye image to be selected for projection to the screen and the right-hand pair will do the same for the right-eye image.

The beam-splitter is a device that does exactly what its name implies—it splits the light beam into two parts. Hence, the intensity of each part cannot be greater than half of the whole beam. It is a simple device and easy to use.

Beam-Splitter Deficiencies

But in addition to light loss, it has another drawback. The pictures overlap considerably, making it impossible to mask them to a stereoscopic window. The window must be artificially produced by a black border on the screen, usually of velvet, to absorb spill-over light. Another shortcoming: The camera lens works at something less than half the *F* stop setting shown on the lens. This means more than twice the amount of light required for conventional photography.

When it comes to shooting interiors, this added light requirement proves to be an economic disadvantage of the beam splitter method. There is a correspond-

ANSWER TO YOUR TECHNICAL PROBLEMS...



The
Altec
Service
Man

*The Altec
Service Man and
the organization
behind him*



161 Sixth Avenue,
New York 13, N. Y.

PROTECTING THE THEATRE—FIRST PLACE IN ENTERTAINMENT

NEVER HAS

Economy

BEEN SO

ESSENTIAL AS NOW!

THERE IS A LORRAINE CARBON TAILORED FOR
YOUR SPECIFIC PROJECTION REQUIREMENT

Send necessary projection equipment
data to guide us in recommending the
Lorraine Carbons that will do your
theatre or drive-in projection job better
and More Economically.

SLOW BURNING

SAVINGS IN POWER CONSUMPTION

SAVINGS IN MAINTENANCE

ECONOMIZE

WITH *Lorraine
Carbons*

Lorraine CARBONS, INC., BOONTON, N. J.

ing light loss in projection, and here the loss is even more significant. Take the loss inherent in the beam splitter, add that to the loss in polarization, and you find that you're getting about one-twelfth the light that you had when you projected the full frame in the conventional way.

Another disadvantage of the beam-splitter is the picture proportions it gives—a narrow and tall picture, certainly inappropriate for stereoscopic representation which is so well suited for panoramic views.

Other Proposed Devices

Another proposed device has dual lenses producing square pictures side by side. There is no light loss in the camera, since two lenses are used and the window for each picture is quite sharp. However, there is considerable loss in projection if the attachment is used on a projector not provided with a special condenser system. If the standard proportions are retained, each image is less than one-fourth the area of the full frame.

Another method which has been proposed for simultaneous projection, is the arrangement of images with one member above the other. Special projectors would be required.

Sequential Frame Projection— The 'Eclipse' System

From time to time, the alternate projection of the members of a stereo pair has also been proposed. In this system, the right eye image, for instance, is projected first, then the shutter interrupts the light beam while the film moves down to position the left eye image. Thus there are periods of flicker that occur at different times for each eye.

If we break this sequence of events down, we find that the first light period has a value of 12.5% of the complete picture cycle. The flicker blade on the projector shutter (considering a two-bladed shutter) gives a dark period lasting 12.5% to be followed by a light period of the same, then a long dark period consuming 62.5% for pull-down and eclipse to permit the other eye to see its image.

If standard sound-film speed of 24 frames a second is used, the resulting flicker is very annoying. Stepping up the projection to 48 frames a second increases flicker frequency twice, but it still is noticeable.

Physiological Effects

There is a physiological effect that is likely to become disagreeably apparent—usually headache or nausea—after a few minutes of viewing pictures projected in this way. A complete period of darkness for one eye, while light reaches the other, will probably always result in visual fatigue, if not in nausea, no mat-



Your patrons will notice the difference! Super Snaplites give you Sharper Pictures, More Illumination, Greater Contrast and Definition.



Clear
Crisp Pictures
with
SUPER SNAPLITE
f/1.9
PROJECTION LENSES

For the Best in Projection use Super Snaplites . . . the only Projection Lenses to give you a true speed of f/1.9 in every focal length up to 7 inches.

Ask for Bulletins
207 and 209

KOLLMORGEN
2 Franklin Avenue
Brooklyn 11, New York

Optical **CORPORATION**



"YOU GET MORE LIGHT WITH SUPER SNAPLITE"

ter how high, within workable limits, the flicker frequency is brought.

Flicker of low frequency calls for traction on the control muscles of the irises

when bright light enters one or both eyes. The rapid occurrence of the transmission of stimuli, first from one eye, then from the other, and the motor messages from the brain to the muscles, delivered in rapid sequence, probably accounts, in part, for the visual discomfort experienced by most people when viewing "eclipse" stereo movies.

Perception of flicker depends upon the intensity of the interrupted light, as well as the flicker frequency. The more intense the light, the higher the frequency must go before flicker fusion is attained. Also, the larger the angular field over which flicker is distributed, the greater the consciousness of flicker. Hence the dimmer the picture and the smaller it is, the lower becomes the flicker fusion frequency.

Projecting 'Eclipse' Stereograms

There are two ways to project and view eclipse stereograms. One is by using rotating or vibrating shutter devices held up in front of the eyes. These are synchronized electrically with the projector. The other method is to employ a rotating polarizer in front of the projector lens and polarizing spectacles for the viewer. In one position the polarizer delivers light through the left spectacle filter. In the other through the right filter.

Alternate frame, or eclipse, projection must have twice the number of frames required for conventional films. That means doubling the length and providing for faster projection speed.

If the alternate frames are photographed alternately, there is a very objectionable fringing in pictures of moving objects. This is a cause of eyestrain, especially in a picture where the action seen by one eye is in quite a different stage of progress than the action seen by the other. Difficulty in fusion invariably results. This combination of disturbing effects caused by flickers out of phase between the eyes and by fusion trouble, limits the appreciation of the eclipse method.

Complete visual comfort can be attained in stereo movies only if the two images are projected simultaneously, if they are rock-steady, if they are of equal brightness, if they are of equal contrast, if they are properly aligned vertically and horizontally, if far distant points are not separated too far in one image from that of the other, and if they are of exactly the same size.

NOTE: IP will present soon, possibly in the next issue, complete technical data on a system for three-dimensional motion pictures which is startlingly simple, eminently practical and truly economical.—ED.



**You Can't Buy
A GOOD
Rectifier
for Less!**

Strong Rectifiers are the only rectifiers on the market which are especially designed, manufactured and tested in one plant together with and for use with motion picture projection arc lamps. This is highly important, as efficient operation of each type and rating of arc necessitates a rectifier specifically engineered to its particular requirements.

There is a dependable Strong Rectifier for every type projection lamp: 2-Tube • 4-Tube • 6-Tube • Single and Three Phase Models for

- Rotating Feed Angular Trim High Intensity
- Copper Coated Coaxial High Intensity
- 1 K.W. High Intensity
- Low Intensity

All assure smooth output current, long life, low operating temperature, and flexibility in control.

WRITE FOR LITERATURE OR FREE DEMONSTRATION

THE STRONG ELECTRIC CORP.
CITY PARK AVE. TOLEDO 2, OHIO
PROJECTION LAMPS
SPOTLIGHTS • RECTIFIERS • REFLECTORS

BUY U. S. SAVINGS BONDS

Your Very Best Buy

BUY U. S. SAVINGS BONDS

PROJECTIONISTS ALREADY HAVE TROUBLE ENOUGH

When a projectionist presses the button to open the curtain and get the show underway, he expects the curtain to open—and so does the boss.

Failure of the curtain control equipment at that critical point sends blood pressure zooming, clips many a useful year from the projectionist's life. It also sends spectators' blood pressure skyward, clips many a dollar from the box office take.

Wise projectionists avoid all these difficulties by recommending to the boss that he install Vallen curtain controls, tracks and special operating devices. They've been answering projectionists' demands "on the button" for 35 years, because they're precision-engineered to do their job.

Put a Vallen catalog in the front office now. Just drop a note, asking for a new catalog, to VALLEN, INC., Akron 4, Ohio.

**ONLY
Century PROJECTORS
HAVE EVERYTHING**



4-inch diam. lens mount

Water-cooled apertures

Oil-less Bearings

CENTURY'S high-efficiency projector with the NEW 4-inch diam. lens provides pictures of increased brightness and appeal—for even the largest drive-in screens.

CENTURY'S water-cooled aperture gives as much light with a 90 ampere arc as other projectors using a 180 ampere arc and heat filters!—Reduce power cost—Get sharper pictures—Save film.

CENTURY'S sealed, oil-less bearings and glass-hard gears reduce maintenance costs. No oil sprays or baths to mess up film or projection room.

You can SEE and HEAR the difference!

CENTURY PROJECTION AND SOUND SYSTEMS
See your dealer or write for information

CENTURY PROJECTOR CORPORATION 

New York, N. Y.

ALL-PURPOSE FILM LEADER

(Continued from page 10)

with the entire content of the leader. In this way the information in it which is not pertinent to the particular use can be ignored and full attention can be given to the useful cues.

Production Footage Cues

For instance, suppose a production director is primarily interested in the footage cues. He may at first see the sound cues too clearly, but once they have become familiar, and he knows they are of no importance to him, they

will recede in visual impact and become completely unnoticed.

Familiarity With Pattern

Again, a theater projectionist may be primarily interested in the threading cues and feel that the Tv pattern is confusing; but once he thoroughly understands the pattern, it is of no interest and so diminishes in importance, permitting the useful cues to emerge. Whenever a little time has been allowed for this phenomenon to take place, no permanent objections have been registered.

3.2: Some feeling has been expressed that the leader is "hard to print." As compared with the dupe of a dupe of a dupe sometimes used for the old leader, it is somewhat more difficult. But any good laboratory can do a thoroughly acceptable job without difficulty, and the result is good dressing for a fine printing job.

Dual Standards Avoided

At first there was some feeling that a special Tv leader might be produced which would exist as a special-service standard and leave unmodified the old Academy Leader. At that time major design changes were considered, including 24-frame spacing for the threading cues. However, after long debate by representatives of laboratories and projectionists, it was decided that the problems of dual-purpose release (including reduction printing) and the confusion always resulting from dual standards could be avoided by a proper common-use leader design. Thereafter all the efforts of the Subcommittee were directed toward the production of a leader to fit this policy.

From the beginning excellent cooperation was obtained from producers, laboratories, projectionists and broadcasters, resulting in the issuance on April 19, 1950, of the first sample leader (in card form) for limited comment and criticism. Some two months later these comments were embodied in the first sample leader film intended for actual test use. It was then discovered that the projected visual impact of the footage cues was insufficient to permit good cuing, so the two additional cue frames were added, and that version of the leader was tested with good results.

Samples of the new leader were sent to many organizations. Again the reactions were reasonably approving, except that the Motion Picture Research Council objected on the grounds that the leader would work an undue hardship on theater projectionists.

Projectionist Aid

In order to obtain the reactions of professional theater projectionists to the proposed leader, the services of the Projectionists' Union were enlisted. After several weeks of consideration an en-

Got your bearings?
(IN BEST POSSIBLE CONDITION, WE MEAN)



They Can Play a Vital Role in making a show a "shooting gallery" or famous for smooth, perfect pictures.

It costs so little to replace worn parts with perfect, precision-made LaVeZZi SUPER SERVICE parts — identical, completely interchangeable, perfect in fit and performance, hardened and ground to give many extra months of trouble free projection. Your Theatre Equipment Dealer has them.

LA VEZZI MACHINE WORKS
4635 WEST LAKE STREET
CHICAGO 44, ILLINOIS

SUPER LaVeZZi SERVICE

Since 1908



THE OPERATORS' FAVORITE!



GoldE's Automatic Enclosed Rewind Always Works! Silent, safe, U.L. approved! Eliminates fire hazard. Positive friction... can't clinch film. Tilt-back case... reels can't fly off. Microswitch safety cut-off... when door opens or film breaks, motor stops!

AT BETTER THEATRE SUPPLY DEALERS
GOLDE MANUFACTURING COMPANY
DEPT. IP. 1220 W. MADISON ST. • CHICAGO 7, ILL.



Stop
BEING A CARBON WASTER

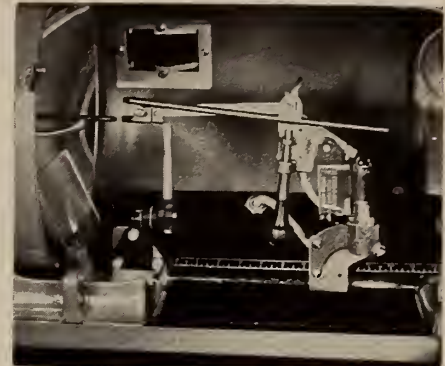

The practice of throwing away carbon stubs can cost you thousands of dollars.

THE CRON-O-MATIC Fully Automatic CARBON SAVER CUTS CARBON COSTS 25%

Uses stubs of all lengths without any preparation. It's no longer necessary to guess whether or not a carbon stub will burn a full reel. Simply insert in the holder. When it is entirely consumed, the new carbon goes into use without losing the light. The Cron-O-Matic in no way interferes with the regular operation of the lamp.

Start saving big money now.

Adaptable to Ashcraft "D", Brenkert-Enarc, Peerless Magnorc and Strong Mogul lamps. Only \$52.50. Quickly pays for itself... then goes on to make money for you.

SOLD BY

- | | | | |
|------------------------------------|------------------------------------|----------------------|------------------------------------|
| ALBANY, N. Y. | National Theatre Sup. | DENVER, COLO. | National Theatre Sup. |
| ATLANTA, GA. | Southeastern Theatre Equipment Co. | JACKSONVILLE, FLA. | Southeastern Theatre Equipment Co. |
| BOSTON, MASS. | Joe Cifre, Inc. | KANSAS CITY, MO. | Shreve Theatre Supply |
| BUFFALO, N. Y. | Eastern Theatre Supply Co., Inc. | MEMPHIS, TENN. | Monarch Theatre Supply Co., Inc. |
| CHARLESTON, W. VA. | Charleston Theatre Supply | NEW ORLEANS, LA. | Southeastern Theatre Equipment Co. |
| CHARLOTTE, N. C. | Southeastern Theatre Equipment Co. | PITTSBURGH, PA. | Atlas Theatre Supply |
| CINCINNATI, OHIO | Midwest Theatre Supply Co. | SALT LAKE CITY, UTAH | Service Theatre Supply Co. |
| DALLAS, TEX. | Hardin Theatre Supply Co. | SAN FRANCISCO, CAL. | Western Theatre Sup. |
| Southwestern Theatre Equipment Co. | | | |

If your theatre equipment dealer cannot supply you, order direct.

PAYNE PRODUCTS COMPANY

Cron-O-Matic Division
2454 W. Stadium Blvd., Ann Arbor, Mich.
() Please send free literature on Cron-O-Matic Carbon Saver.
() Please ship Cron-O-Matic Carbon Saver, { } C.O.D., including postage.
{ } Remittance herewith.

NAME
THEATRE
STREET
CITY & STATE

Dealer Inquiries Invited
Export: Frazar & Hansen, Ltd.
San Francisco, New York, Los Angeles

thusiastic report thereon was received.

Other meetings considered and adopted or rejected proposals received until on March 22, 1951, the Subcommittee decided that the foundations for the new leader had been well established. that the time had come to request that it be publicized to the fullest, with the broadest sort of operational and functional test, directed toward the writing of an official standard. This status report is intended to be the first step in that direction.

When and if the parent Committee decides that the above extensive test may be undertaken, the Subcommittee will canvass by letter the Tv film producers and advertising agencies, requesting that the new leader be used on their special releases. It is hoped, also, that the major feature film producers will cooperate in the test. Certainly in this way all possibilities can be explored and all answers firmly given.

THE MAGIC OF COLOR

(Continued from page 6)

at Technicolor prints, however. For some reason the framelines are printed in silver. When printed too heavily, the framelines fog at the edges and encroach upon the picture area, reducing its height so that framing is extremely critical. In fact, more slight misframes occur with Technicolor than with any other type of print. The projectionist must always be on guard to clear the top or bottom of the picture from the frameline when running Technicolor.

This mischief is almost wholly due to the ill-advised recommendation of the SMPTE regarding the dimensions of the camera aperture. Existing conditions could be improved considerably by using thinner framelines — in other words, larger camera apertures. The present SMPTE standard for the height of the camera aperture is 16 mm (0.63 in.). This should properly be 17 mm (0.67 in.), a fact recognized by certain foreign manufacturers of movies cameras.

Other Tricolor Processes

In addition to the tricolor Technicolor process, two other tricolor subtractive processes appeared commercially in 1932. These are the Agfacolor (German) and Kodachrome (American). Agfacolor is very important in Europe and Asia; but Kodachrome has appeared in theatres only *via* Technicolor prints. Both are variants of a process, first suggested by du Hauron in 1869.

Other and later variants are AnscoColor (a development of Agfacolor); Technicolor Monopack (development of Eastman Kodachrome), and DuPont's Polymer Color Film. All of these films have three distinct layers of emulsion, each layer made sensitive, either by means of photo-sensitizing dyes or by color-filter layers, to only one of the three primary colors.

du Hauron Specifications

Ducos du Hauron specified a glass photographic plate coated with three emulsion layers. In front there was to be placed a slow, very transparent yellow-dyed emulsion sensitive only to indigo light. Behind this there was to be a moderately transparent magenta-dyed

Cannes Amateur Film Festival

The Ciné Club de Cannes (France) will again sponsor an International Festival of the Film Amateur at the Palais de Cannes from Sept. 8 through the 18th, next. Amateurs throughout the world are invited to participate, with all categories of amateur film being acceptable—8-mm, 9½-mm, and 16-mm, silent or sound. Full details from the Club at 20 Blvd. de Lorraine, Cannes.

HANOVER *Continuous* CARBON BURNER

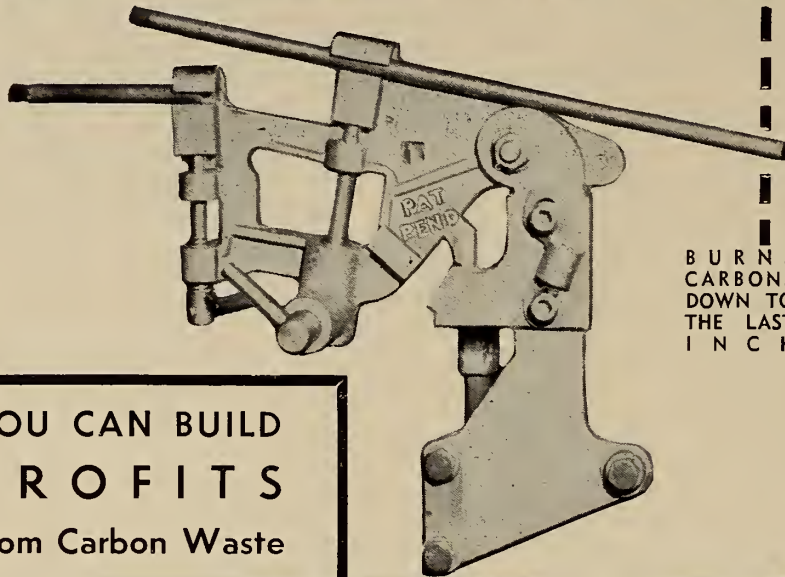

YOU CAN BUILD
PROFITS
From Carbon Waste

5 YEAR PRODUCT GUARANTEE . . . MONEY BACK GUARANTEE

UNBEATABLE FEATURES: Any operator can install it . . . quickly, easily in a Suprex type lamp. Parts don't wear out—no maintenance cost. Precision built, completely automatic. Pre-heats incoming carbon. No disruption or loss of light in changeover. Eliminates uncertainty of burning period of any size carbon stub. Pays for itself immediately by using accumulated waste.

TELL THE MANAGER TO ORDER TODAY

NORPAT SALES, INC.
45 W. 45th St., New York 19, N. Y.

Dear "Doc":

Please send C.O.D. a Hanover Continuous Carbon Burner at \$77.50. I will install it immediately. If not satisfied after 5 days from date unit is received I may return it for full refund.

Lamp mfr. _____ and Type _____
Pos. Carbon Size _____ mm.
Name _____
Address _____
City _____ Zone _____ State _____

WENZEL PROJECTOR CO.

Manufacturers of Many Types of

FILM REWINDERS

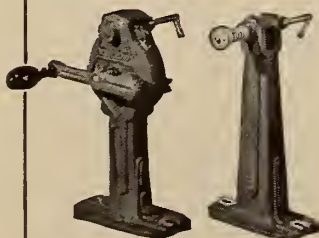

8 M/M
16 M/M
35 M/M
Film

Write for
Illustrated
Brochure

WENZEL PROJECTOR CO.

2505-19 S. State St.

Chicago 16, Ill.

Pro-50
Projector
Head

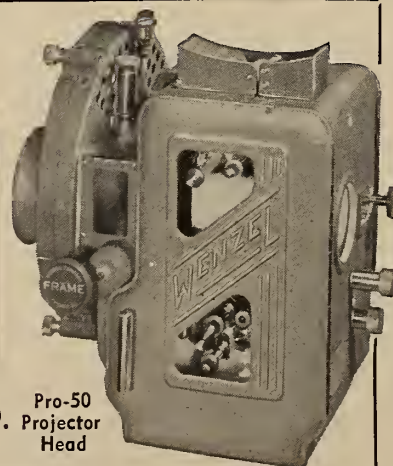

emulsion sensitive to emeraude; while the bottom emulsion was to be a cyan-dyed emulsion sensitive to vermilion—the only color passed by the yellow-and magenta-dyed layers.

This process works because, under certain conditions, a photographic emulsion becomes sensitive to the color absorbed by the admixed dye. The color absorbed is, of course, complementary to the color of the dye. Thus, ordinary black-and-white panchromatic films are sensitized to red by mixing certain green dyes with the emulsion.

The exposed plate was developed, reversed, and finally treated with chemicals which "fixed" the dye images which then appeared in full natural color when the excess dye and silver images had been bleached and washed out of the three emulsions.

Triple-Emulsion Film

A variant of this process uses filter layers of dyed gelatine between the three emulsions. The first emulsion, undyed and unfiltered, is a slow "positive" emulsion which is affected only by indigo light. This emulsion therefore furnishes the indigo record. Behind this is placed a layer of yellow gelatine.

Now, yellow transmits both emeraude and vermilion light. But the emulsion directly behind the yellow layer is an orthochromatic emulsion sensitive to all colors except vermilion. Only emeraude affects this emulsion, however, because the yellow layer cuts off the indigo. Between this emulsion and the bottom emulsion there is a layer of vermilion-dyed gelatine. This cuts off all colors except vermilion. The bottom emulsion, being panchromatic, is sensitive to this color.

The processing of this triple-emulsion film is rather complicated. Briefly, it is reversal-processed and then bleached and treated with chemicals which form yellow, magenta, and cyan dye-images by virtue of dye intermediates incorporated into the three emulsions. The end result is a direct positive in natural colors.

Certain variants of the monopack process—Agfacolor in particular—have been so improved in recent years that they are almost as easy to process as black-and-white films. Moreover, the contrast factors of the three emulsions have been equalized to correct the tendency of monopack to appear bluish if slightly underexposed in the camera. This same tendency has been responsible for distinctly blue shadows in scenes photographed in the less perfect monopack systems.

Monopack may be reversal-processed (as is usually done in America) or "straight developed" into a negative having all tones, including the colors, in reverse. From such a negative, monopack positives may be printed with ease and

in any desired number. Color values may be balanced in any way desired during the printing process by means of lightly-tinted filters. Like Technicolor, Agfacolor is balanced for the "color temperature" of the high-intensity arc.

Agfacolor, Kodachrome Processes

Certain noteworthy advantages are claimed for modern Agfacolor. It is as simple to use as black-and-white film. It is almost as easy to process—any film laboratory can handle it with only minor modifications in the processing equipment. And because it is a monopack process, registration of the three colors—

yellow, magenta, and cyan—is always perfect. A satisfactory sound-track can be printed in dye image. In a word, all the difficult "bugs" of color photography are overcome during the manufacture of the raw stock.

Kodachrome, like Agfacolor, has an indigo-sensitive top emulsion, an emer-

BUY U. S. SAVINGS BONDS

Your Very Best Buy

BUY U. S. SAVINGS BONDS

NATIONAL HAS EVERYTHING
FOR THE PROJECTION ROOM

Get it
from
National!

NATIONAL
THEATRE SUPPLY
Division of National • Simplex • Bludworth, Inc.

29 BRANCHES • COAST TO COAST

CLAYTON BALL-BEARING EVEN TENSION TAKE-UPS

For all projectors and sound equipments

All take-ups wind film on 2, 4 and 5 inch hub reels.
Silent Chain Drives

THE CLAYTON REWINDER

For perfect rewinding on 2000-foot reels.

CLAYTON PRODUCTS CO.
31-45 Tibbett Avenue New York 63, N. Y.

aude-sensitive middle emulsion, and a vermilion-sensitive bottom emulsion. Dupont Polymer Color Film switches the positions of the indigo- and vermilion-sensitive layers.

The individual emulsion layers are only about 1/10,000 of an inch thick, making monopack only a trifle thicker than ordinary black-and-white film.

Theatre-release prints of Monogram shorts on Ansco Color 35-mm monopack film are familiar to many projectionists in America.

Duplitzed Film Stock

No discussion of movie color processes would be complete without a mention of the so-called "duplitzed" (double-coated film) processes. With the exception of a few 3-color films prepared by Cinecolor, these are all 2-color processes—Cinecolor, Trucolor, Magnacolor, etc.

The two complementary colors used by old-style Technicolor were crimson and aquamarine. The results with this combination were remarkably good, considering the limitations of the 2-color process; but it was impossible to reproduce truly blue sky with 2-color Technicolor. Since the ability to photograph blue sky is a prime requisite for the production of "outdoor" color movies, both Cinecolor and Trucolor have adjusted their set of complementaries to effect this end. Cinecolor, for example, uses vermilion and cyan. (To refresh the memory: vermilion is orange-red, and cyan is a slightly greenish blue.)

There are several ways to photograph and process duplitzed films. To produce the 2-color negative, simultaneous 2-frame exposure through vermilion and cyan filters may be made in a split-beam camera as in old-style Technicolor; or two films, one sensitive to red and the other to blue, may be run together in bipack in an ordinary movie camera fitted with double magazines; or a single duplitzed color negative may be used. The bipack method has been the most popular.

In a 2-color bipack the negative nearest the camera lens has a regular positive-type emulsion which is sensitive only to blue colors. The back of the film is coated with vermilion-dyed gelatine to act as a filter for the panchromatic film behind it. This latter film thus records only the red-orange colors.

The two negatives are developed to black-and-white, and are used for printing the duplitzed release positives photographically. The imbibition process, exclusive with Technicolor, is not used.

Nature of Duplitzed Stock

Duplitzed raw stock is merely ordinary double-coated positive film except that *both* gelatine "bonding layers" which lie beneath the photographic emulsion, and which serve to make the emul-



• The NEW, improved, positive method of permanently patching all types and makes of film—8mm., 16mm., 35mm., Trucolor, Technicolor, Kodachrome, Nitrate and Safety Film.

Used and endorsed by Projectionists in countless theaters.

specifically for *lasting Patches.*

ESSANNAY ELECTRIC MANUFACTURING CO.
Chicago 10, Illinois 1438 North Clark Street



sion adhere firmly to the film-base, are dyed a *deep orange-red.*

Now, the purpose of the red bonding layers is to permit the two sides of the duplitzed film to be printed individually. Positive emulsions are insensitive to red; so when one side of the duplitzed film is printed, the other side is not affected at all, and is afterwards printed separately. (Or both sides may be printed simultaneously in a duplex picture printer.)

One side is printed from the "red" negative and the other side from the "blue" negative, corresponding frames of the two negatives being superimposed on the duplitzed print.

The film is then developed in the ordinary way, coming out as a double-coated, black-and-white film having pictures on both sides. A thorough washing removes the soluble red dye of the binder layers—or at least most of it. If not all of the dye is washed away, the finished print will have an orange tint all over on both sides, as every projectionist knows.

The 'Dye-Toning' Operation

Now for the "dye-toning" operation which puts the color into the duplitzed print. After developing, the film is bleached to a silver chloride image. The print is then passed through a special processing machine which transfers toning chemicals to each side. After subsequent washing and drying the print is ready for use. The side printed from the vermilion-exposed negative is toned cyan; the other side vermilion.

The two colors of Cinecolor, Trucolor, and other duplitzed prints are oriented so that the blue, or cyan, images are on what would be the normal emulsion side of a standard 35-mm print. This is done so that the soundtrack, printed in blue, will be in correct focus.

Unlike Technicolor's cyanine-blue dye, the blue ferricyanide image on duplitzed prints is comparatively opaque to infrared rays, thus making a non-silver soundtrack possible. (Technicolor cyan, however, is a much more "saturated" and accurate color, far superior to metal-organic compounds for the purposes of colored pictures.)

[TO BE CONTINUED]

How Many?

Was this copy dog-eared when it came to you? How many men read it ahead of you?

You would receive a clean, fresh copy if you had a personal subscription—and you wouldn't have to wait—you would be first to read it.

Use coupon below.

INTERNATIONAL PROJECTIONIST,

19 West 44 St., New York 18, N. Y.

Enter my subscription for

1 year—12 issues—\$2.50

2 years—24 issues—\$4.00

Foreign and Canada: Add 50c per year.

Name

Address

City State

★

★

Medal of Honor

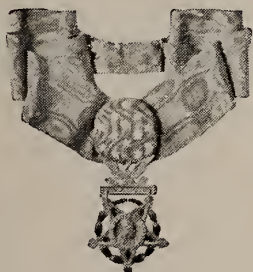

Private First Class Melvin Brown, of Mahaffey, Pennsylvania—Medal of Honor for valor in action near Kasan, Korea, September 4, 1950. Stubbornly holding an advanced position atop a wall, Pfc. Brown stood off attacking North Koreans until all his rifle ammunition and grenades were gone. When last seen he was still fighting—with only an entrenching shovel for a weapon—rather than give up an inch of ground.

Never forget the devotion of Melvin Brown!

Now, this very day, you can help make safer the land he served so far “above and beyond the call of duty.” Whoever you are, wherever you are, you can begin buying more . . . and more . . . and more United States Defense* Bonds. For every time you buy a bond you’re helping keep solid and stable and strong the country for which Private Brown gave everything he had.

And remember that *strength* for America can mean *peace* for America—so that boys like Melvin Brown may never have to fight again.

For the sake of Private Melvin Brown and all our servicemen—for *your own boy*—buy more United States Defense Bonds now. Defense is your job, too!

Remember that when you’re buying bonds for national defense, you’re also building a personal reserve of cash savings. So go to your company’s pay office—now—and sign up to buy Defense Bonds through the Payroll Savings Plan. Don’t forget that now every United States Series E Bond you

own automatically goes on earning interest for 20 years from date of purchase instead of 10 years as before. This means, for example, that a Bond you bought for \$18.75 can return you not just \$25 but as much as \$33.33! For your country’s security, and your own, buy U. S. Defense Bonds now!

***U.S. Savings Bonds are Defense Bonds - Buy them regularly!**



The U. S. Government does not pay for this advertisement. It is donated by this publication in cooperation with the Advertising Council and the Magazine Publishers of America as a public service.

Simplex TRADE MARK REG'D **CHOSEN AGAIN!**

by **ESSANESS** For Chicago's
4-Screen Drive-In

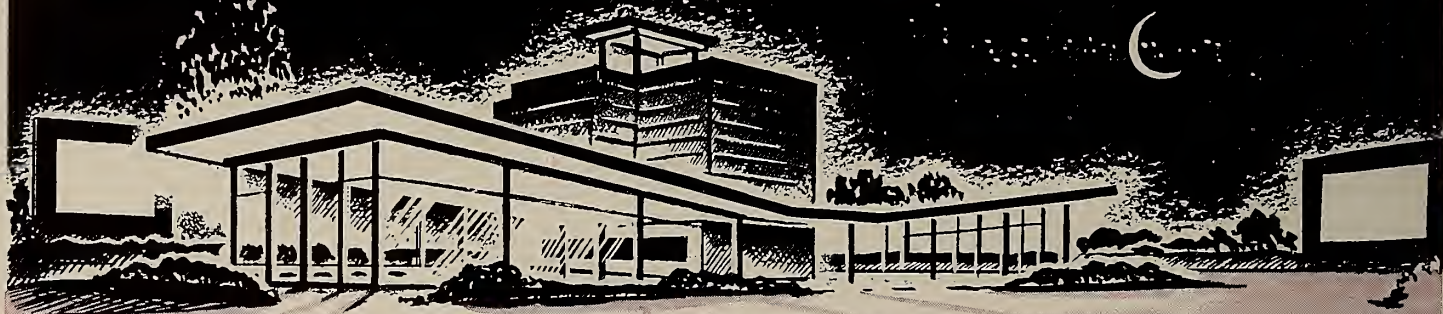

THE WORLD'S FIRST 4-SCREEN DRIVE-IN THEATRE
EQUIPPED WITH SIMPLEX X-L—FIRST IN MOTION PICTURE PROJECTORS

ESSANESS THEATRE CIRCUIT, owners and operators of the world's first 4-screen theatre, realizes that its success depends upon more than mere novelty. It depends upon the continual maintenance of the very highest standards of motion picture entertainment. That's why ESSANESS chose to install SIMPLEX X-L, the finest in motion picture projectors!

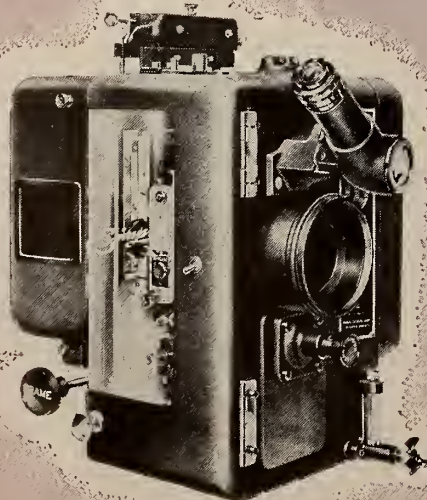

Simplex

TRADE MARK REG'D

X·L

PROJECTOR

MANUFACTURED BY INTERNATIONAL PROJECTOR CORPORATION • DISTRIBUTED BY NATIONAL THEATRE SUPPLY

323352

PROJECTIONIST

**I
N
T
E
R
N
A
T
I
O
N
A
L**

OLC - 185

THE LIBRARY OF
CONGRESS
SERIAL RECORD
OCT 1 1951
copy



THE LIBRARY OF
CONGRESS
SERIAL RECORD
OCT 18 1951
copy

SEPTEMBER

1951

VOLUME 26



NUMBER 9

30c A COPY • \$2.50 A YEAR

ALONGSIDE THESE LAMPS STAND THE WORLD'S FINEST PROJECTIONISTS

Peerless

1-KW TO 70 AMPS

MAGNARC
TRADE MARK REG

"HY-AX" ARC MAGNET

"HY-LUMEN" REFLECTOR

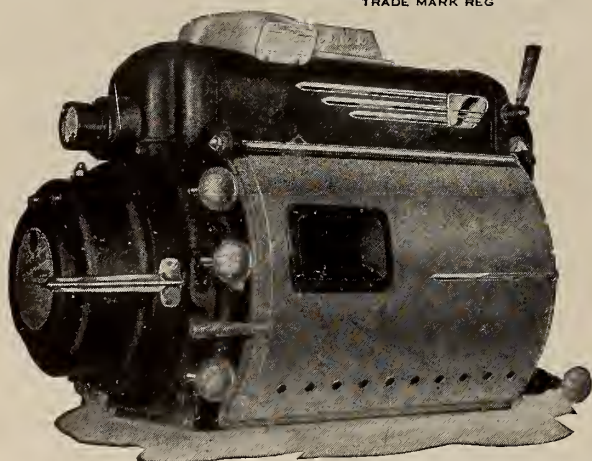

More light at 40 to 70 amperes than ever thought possible. . . . Equals and excels any reflector lamp to 85 amperes, whether they be unapproved water-cooled or resurrected "Hi-Lows". . . . Highest ratio of honest screen lumens per arc watt. . . . At 70 amperes, using an accuroted Glass Hy-Lumen Reflector*, with a projector having an efficient revolving shutter, it develops the maximum screen brilliance that can be used without a heat filter of no risk of film damage. . . . Operating costs under these conditions are far below that of 85-ampere lamps.

Magnarc Lamps assure 80% side-to-center (SMPE Standord) screen light distribution, not a deceptive 60% or "Hot Center". . . . They are all Und. Lab., Inc. listed. . . . They are *not* insurance hazards. . . . They ore ond have been for years "The First Choice" of lorge ond small theatres, drive-ins, and the motion picture industry.

* Similar results are *not* guaranteed if *oil-metal* reflectors ore used.

"FIRST WITH THE FINEST"

130-180 AMPERES

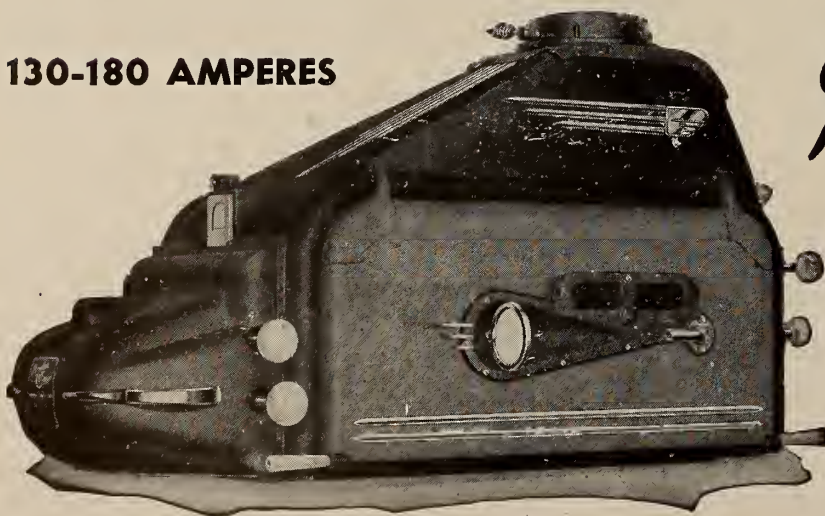

Peerless
HY-CANDESCENT
TRADE MARK REG

NEW MAGNETIC STABILIZER

This modern lamp produces all the light there is. . . . It is the standard equipment of the nation's largest and finest theatres. . . . Used by 90% of the largest Drive-In Theatres.

It is the "Omega" for maximum screen brilliance. . . . Nothing can even approach it in *white* light volume when used with projectors that have efficient revolving shutters.

Assures satisfying projection for Drive-Ins regardless of the size of the picture, length of throw, and under all weather conditions. . . . They ore Und. Lab., Inc. listed and, therefore, *not* insurance hazards. . . . Heat filter assures no risk of film-heat damage at maximum arc amperage ond maximum screen lumens.

"WHY EXPERIMENT?"



J. E. McAULEY MFG. CO.

552-554 WEST ADAMS STREET
CHICAGO 6, ILLINOIS

INTERNATIONAL PROJECTIONIST

With Which Is Combined PROJECTION ENGINEERING



HENRY B. SELLWOOD, *Editor*

Volume 26

SEPTEMBER 1951

Number 9

Index and Monthly Chat 3	In the Spotlight 16 HARRY SHERMAN
The Magic of Color V. Conclusion 5 ROBERT A. MITCHELL	N. T. S. Observes 25th Birthday 18
The Scientific Basis for Estab- lishing Brightness of Motion Picture Screens 9 SMPE ROUND-TABLE DISCUSSION	Exhibitor-Producer Group Meet to Spur Theatre Tv 19
The Allied Arts & Sciences I. Photographic Optics 13 BAUSCH & LOMB OPTICAL CO.	Letters to the Editor 20
	News Notes
	Technical Hints
	Miscellaneous Items

Published Monthly by

INTERNATIONAL PROJECTIONIST PUBLISHING CO., INC.

19 West 44 Street, New York 18, N. Y.

Telephone: MURRAY HILL 2-2948

R. A. ENTRACHT, Publisher

SUBSCRIPTION REPRESENTATIVES

AUSTRALIA: McGills, 183 Elizabeth St., Melbourne

NEW ZEALAND: Te Aro Book Depot, Ltd., 64 Courtenay Place, Wellington

ENGLAND and DOMINIONS: Wm. Dawson & Sons, Ltd., Macklin St., London, W. C. 2

YEARLY SUBSCRIPTION: United States and possessions, \$2.50 (two years, \$4); Canada and foreign countries, \$3; single copies, 30 cents. Changes of address should be submitted two weeks in advance of publication date to insure receipt of current issue. Entered as second class matter February 8, 1932, at the Post Office at New York, N. Y., under the act of March 3, 1879. Entire contents copyrighted 1951 by International Projectionist Publishing Co., Inc. INTERNATIONAL PROJECTIONIST is not responsible for personal opinions appearing in signed articles in its columns.



MONTHLY CHAT

THE motion picture theatre—and the whole pattern of making, distributing and showing motion pictures as we have known it to date—is embarking upon its most crucial season from the standpoint of competition for the entertainment dollar. Much more is involved in this situation than the dollars invested in studios, theatres and other facilities: the major stake is the livelihoods of thousands of workers who have been placed in a precarious position largely through the ineptness, the timidity and the downright ignorance of the so-called executive brains of the industry.

Not a new theme for this department, but a story ever new and growing more important with every passing day.

Time and again we have cited in this corner the several technological advances which, if promptly and properly utilized, would have placed in a deep shadow the current "Movietime, U. S. A." drive as a builder of box-office receipts. Exert the major effort *inside*, not outside, the theatre walls. The glamour of personal appearances and thousands of lines of cheery advertising copy is of a strictly transitory nature. They still pay off for that which is shown on the screen.

We're all for such promotional efforts as the Movietime, U.S.A. campaign now in full swing. But the same type of campaign that promoted such technological advances as three-dimensional motion pictures (*without the aid of individual viewing aids*); truly stereophonic sound reproduction, and vastly improved color processes (the list is not all-inclusive) would, we think, be infinitely more effective and certainly of more *lasting* benefit, than any trans-continental trek by a raft of glamour-pusses. Imagine—more than \$2½ million for a campaign that has for its objective inducing people to go to movie theatres—to see that very same entertainment which has been readily available for years past. Now, just imagine if, instead of selling glamour, we had the aforementioned technological advances to sell—permanently, night after night!

If we asked the industry Brass for \$2½ million to perfect any one or all of such technological aids to the showing of better motion pictures, they'd likely freeze into utter speechlessness. Still, just one of these birds managed to collect \$900,000 *salary*, exclusive of expense money, within one year!

We confess that we don't know what can be done about such a ludicrous situation; but we do know that no Movietime, U. S. A. campaign, of whatever magnitude, could ever provide a box-office stimulant comparable to that which is readily available *right now* to every theatre in the land. The making, the showing and the *selling* of motion pictures to the public depends almost wholly on the technical excellence of the product—that which hits the screen and reaches the ears.

The Brightest Pictures Ever Shown Are Within Your Reach



The Strong Mighty '90', 75 to 130 ampere reflector arc lamp, not only delivers positively the most light that can be projected to any screen, **REGARDLESS OF HOW LARGE**, but at 90 amperes projects 21,000 lumens **AT FAR LESS COST** than other types of big lamps!

More dealers sell Strong-made lamps than sell any other make. As the only lamps produced complete within one factory, Strong projection lamps can be so engineered as to obtain the finest screen results, the highest efficiencies ever attained. Long, dependable service is assured. Some Strong lamps, built as long as 28 years ago, are still working every day. That's why, year after year, more theatres prefer Strong lamps . . . why continual expansion of plant facilities has been necessary. As the world's largest manufacturer of projection arc lamps, Strong has a line that includes lamps especially designed for best results under every condition. Send coupon today for free literature.

*When the lamps are **STRONG** - the picture is bright!*

THE STRONG ELECTRIC CORPORATION
Toledo 2, Ohio

31 City Park Avenue

I would like a demonstration of the Strong Mighty '90' in my theatre without cost or obligation.
Please send free literature on the Mighty '90'; Mogul Lamp; Utility Lamp; Strong Arc Spotlamps; Strong Incandescent Spotlights; Strong Rectifiers; Strong Reflectors.

NAME _____

THEATRE _____

STREET _____

CITY & STATE _____



COLOR and the various methods of making movies in natural color were described in the preceding installments. Now, in conclusion, let us direct attention to the *projection* of color films. *This* is our metier. The advantages of filming theatrical motion pictures in natural color are multifarious and self-evident. Some of these advantages are all but lost, however, when the technique of screening color films is faulty.

The quality of projection depends primarily upon the condition of the projection equipment, of course; but there are also other important factors to be considered. If, for example, the prints are bad, or if the projectionist is careless in his work, or if conditions in the auditorium are unfavorable to the best screen results, not even the best equipment can give quality performance.

Technicolor is very "fussy" anent conditions under which its prints are projected—justifiably so—and no effort, no expense is spared to insure quality prints. But it is entirely possible to follow meticulously Technicolor's instructions regarding auditorium lighting, the burning-in of new carbon trims, checking the focus, *etc.*, and still obtain poor color pictures on the screen.

Equipment Condition Governs

The condition of the projection equipment is the governing factor. One can't project good color with low-intensity lamps, uncoated projection lenses, and old-style projector shutters—color quality notwithstanding. The use of obsolete equipment is like playing a modern electrically-recorded phonograph record on a 1910 gramophone.

Low-intensity (L-I) lamps may be acceptable for the projection of black-and-white prints, providing the arcs are bright enough (which they seldom are),

The Magic of Color

By ROBERT A. MITCHELL

V. (Conclusion)

The Projection of Color Films

and providing the exhibitor just doesn't give a damn about screen image quality.

Technicolor prints are balanced in color value for high-intensity (H-I) lighting. L-I arcs have too low a color temperature for the faithful reproduction of colored prints—too yellowish and thus dull all the blues, violets, purples, and purplish reds in the picture. And don't let anyone tell you that the public tolerates a wide divergence from true color values "when there is no standard of comparison." The writer can see the alteration of hue when an amber-tinted print is projected *via* L-I or H-I lighting. You can, too, and so can the average movie-goer. These facts should be seriously pondered in view of the present widespread use of natural color.

'Hot Spot' Screen Effect

Even H-I lighting is not faultless. It's the old, old story of "hot-spot." How can

one possibly get good colors near the edges and corners of the screen if the lamps can do no better than 60- to 80% side-to-center light distribution? It just can't be done.

Yellowish-green turns to an olive shade at the edges of the screen when light distribution is not uniform. Red changes to terra-cotta; blue to a steel-gray; orange to brown; and yellow to a shade too unpleasant to be described. If variations in the color of the projected light accompany the variations in intensity (usually) faces will appear unnatural, and other weird color effects will be produced.

Here is a test which is not so rough but that it will give a fairly good idea of the quality of light-distribution delivered by the lamps.

Project light to the screen—projector running but without film. By means of the mirror knobs, move the spot from side to side or up and down as rapidly as possible. If a "hot-spot" is present, this test will reveal it immediately—no doubt about it. You will actually see the bright center of the illumination-field moving horizontally or vertically on the screen. It is the *movement* of the field of light on the screen which shows up the hot-spot so *plainly*.

Over-All Screen Brightness

If you find a trace of a "hot-spot" notify the manager: he has a right to know the facts about such conditions. Lumens are cheap, but uniform illumination is a rare bird. This is a fact which every exhibitor who wants his money's worth should remember when purchasing new lamp equipment.

Over-all picture brightness is also an important factor in the projection of color films. Colors and their proper contrast values as photographed on the film

appear natural only when the screen illumination lies within certain very definite limits. To be more exact, the brightness of the illuminated screen as seen by the audience should be specified.

For example, the intensity of the projection light falling upon the surface of the screen is measured in foot-candles (ft-c). Now, it is commonly assumed that a minimum of 10 ft-c is necessary for the satisfactory projection of films in natural color. This recommendation does not take into account the degree of whiteness (the reflectance) of the screen, however. A screen besmirched with tattle-gray will not give as bright a picture under 10 ft-c as a new or freshly surfaced screen.

Screen Reflecting Power

Table A lists the approximate reflectances (as percentages) of both perforated and solid matte screens—average, new, and old. This table will give an idea of the reflecting power of your screen, provided you are not using a beaded or aluminum-surfaced screen.

Even a new screen, if it be soiled, is just as bad as an old screen. Screens "age" much faster in cities than in small towns because smoke, dust, and several kinds of chemical fumes are usually present in the air of cities.

The best white bond writing-paper reflects from 65 to 70% of the light falling upon it. It is possible, therefore, to judge approximately the condition of any matte screen by comparing its whiteness with that of fresh writing paper. But if the comparison be made on the stage, 10% must be subtracted because the sound perforations occupy about 10% of the total area of the screen.

Calculated in Foot-Lamberts

It can therefore be appreciated that a specification of ft-c of projection light at the screen cannot tell how bright the picture will appear to the audience. Instead of *foot-candles* (intensity of light from the projector running without film, measured at the screen), the brightness must be specified in *foot-lamberts* (ft-L).

If a screen has a reflectance of 100%, 10 ft-c would furnish a screen brightness of 10 ft-L. No matte screen, however, even if "solid," is able to reflect all the light falling upon it. In fact, a brand-new unperforated matte screen does well

to reflect even as much as 80% of the light. By using such a screen, 10 ft-c of projection light at the screen results in a screen brightness of only 8 ft-L—not quite enough for top-notch results with color films.

The best opinion is that screen brightness should not be less than 10 nor more than 20 ft-L for the projection of modern theater-release prints, including natural-color films, such as Technicolor.

Table B gives the ft-c-ratings (measured at the screen with projector running, but without film) required to furnish 10, 15, and 20 ft-L of screen brightness for perforated and solid matte screens—average, new, and old.

Maintaining Spectral Balance

It seems almost unnecessary to add that an old, soiled screen is very likely to be yellowish in color, besides having poor reflective power. A yellowed screen gives exactly the same color-distorting effects of L-I projection. Yet many exhibitors, apparently expecting their projectionists to perform miracles, postpone the purchase of fresh, white screens capable of reflecting all of the colors in proper spectral balance.

Although considerable latitude in screen brightness is allowed, the hues in a Technicolor picture actually shift slightly in the hue scale if the illumination is too faint or too intense. These changes are caused by the Purkinje (pronounced *poor-keen-ya*) effect.

If the picture is too dim, bright red assumes a slightly magenta cast, orange becomes brick-red, orange-yellow becomes brown, bright yellow appears khaki-colored, and the blues and purples "wash out" to gray. Only the greens appear normal. On the other hand, if the picture be too bright, the reds, oranges and the yellows appear too intense in comparison with the greens; and blue looks slightly violet. Moreover, the deepest blacks in Technicolor prints have sufficient red transmission to actually look red on the screen when too much screen illumination is used.

Too Little, Too Much Light

Then, too, detail in the shadows is lost when the picture is too dim; while a terrific shutter-flicker becomes visible when the picture is too bright. Flicker caused by the rotating shutter (48 cutoffs per second) would not be a problem if we had 5-to-1 intermittents (such as the Powers pin-cross movement) thus permitting 3 shutter cutoffs per frame instead of 2.

Shutter flicker is especially annoying to patrons seated in the front rows because averted vision does not have as much "persistence" as does direct vision. You cannot help but see the flickering of the light when the screen sub-

TABLE B
FOOT-CANDLES TO FURNISH 10, 15
AND 20 FOOT-LAMBERTS

TYPE OF MATTE SCREEN	FOOT-LAMBERTS		
	10	15	20
Perforated:			
Average	18.5	27.8	37.0
New	13.9	20.8	27.8
Old	27.8	41.7	55.6
Solid:			
Average	16.7	25.0	33.3
New	12.5	18.8	25.0
Old	25.0	37.5	50.0

tends a large angle of the visual field.

A picture which is both too big and too bright therefore makes the front rows of seats less useful to the exhibitor than other seats. Everyone except the kids (who want to see the picture BIG at any cost) avoids the "down-front" seats. Exhibitors would find their seats nearer the screen increasing in popularity by using projectors having 5-to-1 intermittents and 3-blade shutters (72 cutoffs per second), for these would permit bigger and brighter pictures with less flicker. At present, however, such machines are not to be had for love nor money, and only the projector manufacturers know why.

We all know that these machines can be made at no increase in cost.

Auxiliary Lighting Effects

Technicolor warns us not to use colored lighting on or near the screen during the showing of Technicolor films, and also to eliminate red and amber decorative lighting in the auditorium. These suggestions are well-founded.

Color-flooding the titles of Technicolor productions, either by projecting the titles on a colored curtain or by using colored foot- and strip-lights, is bad practice because Technicolor titles are designed with artistic care. Color-flooding alters the colors recorded on the film—colors which not only make the titles pleasing to see, but which harmonize the titles with the dramatic mood of the picture to follow.

Nearly every projectionist has color-flooded titles at one time or another. In the case of black-and-white films, the effects obtained are often very pleasing and in good taste: they "dress up" the show and provide an extra note of that glamour to which the motion picture industry owes its very existence.

The titles of comedy-romances and serious dramas, for instance, might advantageously be flooded with pink-ma-

(Continued on page 30)

TABLE A
APPROXIMATE REFLECTANCE OF
MATTE SCREENS

TYPE OF SCREEN	REFLECTANCE (%)		
	AVERAGE	NEW	OLD
Perforated	54%	72%	36%
Solid	60%	80%	40%

The **NATIONAL** Carbon Arc's
TRADE-MARK

BIG 5

means

BETTER MOVIES!

BIGGER BOX OFFICE!

On all movie sets — particularly on medium and large sets — where long throws and deep penetration of light are necessary, the carbon arc offers a unique combination of advantages:

- **SMALL SOURCE SIZE**
- **HIGH BRIGHTNESS**
- **GREAT POWER FROM ONE UNIT**
- **WHITE LIGHT**
- **MINIMUM HEAT PER FOOT CANDLE**

If you're after real quality, the carbon arc is tops. It gives you the kind of sharp, dramatic movies that customers want to see — helps keep box office in the black!



**YOU CAN'T SKIMP ON STUDIO LIGHTING,
WITHOUT RISKING BOX OFFICE!**

*The term "National" is a registered trade-mark of
Union Carbide and Carbon Corporation*

NATIONAL CARBON COMPANY
A Division of Union Carbide and Carbon Corporation
30 East 42nd Street, New York 17, N. Y.

*District Sales Offices: Atlanta, Chicago, Dallas,
Kansas City, New York, Pittsburgh, San Francisco*

IN CANADA: National Carbon Limited.
Toronto, Montreal, Winnipeg



Invitation to Imagination...

Consider the world we live in... Consider the way we live... Consider today's new ideas in motion-picture equipment and materials...

What a tremendous invitation to imagination all this is! No wonder pictures of increasing insight and originality—pictures richer than ever in the use of advanced technics—are now available.

Integral with this progress is the Eastman Kodak Company. Through the Eastman Technical Service for Motion Picture Film, it aids studios and laboratories in the selection and exposure of film, black-and-white and color; helps set up control systems, establish standards of quality and economy, "trouble-shoot" when the need arises; co-operates with exchanges and exhibitors, making sure that each foot of film produces optimum results, gives best possible showing.

To maintain this service, the Eastman Kodak Company has branches at strategic centers... invites inquiry on all phases of film use from all members of the industry. Address:

Motion Picture Film Department

EASTMAN KODAK COMPANY

Rochester 4, N. Y.

East Coast Division
342 Madison Avenue
New York 17, New York

Midwest Division
137 North Wabash Avenue
Chicago 2, Illinois

West Coast Division
6706 Santa Monica Blvd.
Hollywood 38, California

The Scientific Basis for Establishing Brightness of Motion Picture Screens†

By FREDERICK J. KOLB, Jr.

The appended report covers a round-table discussion initiated by Dr. W. W. Lozier, chairman of the SMPTE Screen Brightness Committee. The conference was held at Rochester, N. Y., thus as a matter of expediency only men available there were asked to participate. Participating in the discussion were the following men, all actively engaged in the fields of projection optics and psychology:

DR. LOZIER, National Carbon Co.; from various departments of Eastman Kodak Co.: G. A. CHAMBERS, Motion Picture Film; R. M. EVANS, Color Contrast; D. F. LYMAN, Camera Works; S. M. NEWHALL, Color Contrast; OTTO SANDVIK, Research; K. F. WEAVER, Research; F. J. KOLB, JR., Engineering Experiments; and D. WOOD, Camera Works. Also, from the University of Rochester: BRIAN O'BRIEN, Institute of Optics, and S. D. S. SPRAGG, Department of Psychology.

DR. LOZIER reviewed the background for this discussion by noting that a "temporary standard" for the brightness of motion picture screens was adopted by the Society in 1938, after the available data had been summarized. Slight modification was made in 1944, but actually the interval from 1936 to the present has been characterized by the accumulation of considerable fundamental information without the opportunity for consolidating the data, or for the Screen Brightness Committee to consider modification of the temporary standard.

The present standard for screen brightness (Z22.39-1944), Lozier pointed out, specifies "the brightness at the center of a screen for viewing 35-mm motion pictures shall be 10 ft-L (foot-lamberts) (+4 or -1 ft-L) when the projector is running with no film in the gate."

Origin of the Standard

In discussing the present standard, Lozier pointed out the work culminating in the SMPE symposium of 1935-36 which led to the adoption of a screen brightness standard. The Committee report, relying upon the survey of technical knowledge presented in the symposium, discussed, first, the desirable levels of screen illumination, and second, attainable levels. The fundamental data of physiological optics were not directly applicable to the problem at that time, the Committee concluded, because the work had not been complete enough to permit the prediction of response under theater viewing conditions. Instead, consideration was given to the more practical experiments.

From these observations the Committee concluded that an ideal brightness level probably should be something in the order of 30 ft-L, and that a peripheral brightness of the order of 0.05 ft-L would be desirable at this brightness level.

Properties of Release Prints

Considering next the properties of release prints, the Committee decided that very little change in print density can be expected since: (1) Release prints can be made no more transparent because of the limitations of the existing photographic materials; lighter printing would endanger tone reproduction in the highlights. (2) It would not be practical to increase print density, since an increase of about 0.15 in density would be necessary to place the high-light density of release prints nearer to the straight-line portion of the characteristic curve for positive film: one might thereby improve tone reproduction, but only at the expense of a necessary increase in illumination approximating 40% to maintain equal apparent brightness.

For the slight advantage offered, this

shift in print density (probably requiring a reduction in screen size to maintain picture brightness) was judged impractical.

Considering then what screen brightnesses might be possible with existing equipment, the Committee concluded that for a 30-ft screen an attainable brightness of about 7 ft-L would be the maximum. In order to reduce the discrepancy among theaters, and between theaters and review rooms, the Committee decided that a temporary standard on the basis of attainable brightness would have the advantage of stimulating an over-all improvement in picture quality.

Set 7 ft-L as Minimum

Therefore, assuming that a 30-ft screen might be the maximum size which the Society should attempt to recognize, the Committee decided that the minimum acceptable screen brightness should be 7ft-L.

In order to choose an upper limit the Committee attempted to determine what range of brightness could be tolerated without an objectionable change in the apparent contrast of the picture. It was considered undesirable to set the upper limit at 30 ft-L, since this would result in an excessive spread in screen brightnesses among the various theaters. On the basis of available data, the Committee selected a maximum value of screen brightness such that the predicted apparent change in contrast would be 15% between the average and either extreme (for picture densities corresponding either to the average of the whole frame, or to the area of principal interest).

Modification of Standard

Summarizing its recommendations, the Committee said, "The value 7 is based upon the value attainable for a diffusing screen about 30 ft. wide with an efficient optical system in good adjustment. The value 14 is the limiting value beyond which print contrast adjusted for the mean level of 10 ft-L will appear too great. The value should be determined at the center of the screen, with a projector running, with no film in the gate."

Subsequently, the Screen Brightness Committee suggested a modification in this standard from 7-14 ft-L to 9-14 ft-L

T A B L E I

	Print Density			Screen Brightness, ft-L		
	Min.	Mean	Max.	Max.	Mean	Min.
Average of entire frame	0.67	1.15	1.90	2.1	0.71	0.13
"Face" or area of principal interest . .	0.60	0.99	1.60	2.5	1.0	0.25
Brightest highlight	0.19	0.43	0.90	6.5	3.7	1.3
Deepest shadow	1.87	2.40	3.20	0.13	0.040	0.0063
Highest scene contrast = 2.45			Lowest scene contrast = 1.38			

†J. Soc. Mot. Pict. & Tv Eng., April, 1951

in 1941; the revised standard was adopted by the ASA in 1944.

'Actual' Picture Brightness

It should be emphasized especially for those not used to motion picture practice that the screen brightness as specified by the standard is markedly reduced when there is film in the projector and a picture on the screen. Assuming the available data to be approximately correct for the fine-grain print stock now generally used, *actual picture brightnesses* for a "screen brightness" of 10 ft-L would be as shown in Table I.

The problems of screen brightness for both 35-mm and 16-mm are generally similar, and 16-mm practice has tended to follow the 35-mm standard. It is usual, however, to permit a higher variation from the average brightness in 16-mm installations.

Recent Investigational Work

Since the 1936 symposium there has been considerable discussion and some additional work pertinent to the setting of a suitable screen-brightness standard. Reeb reported results of an experimental study in Germany, investigating the contrast sensitivity of the eye under conditions similar to those found in viewing motion pictures.

The German investigators concluded that maximum contrast sensitivity occurs at about 14 ft-L, that only the central brightness is important in attaining visual effect, that rapid changes in brightness of a scene do not affect sensitivity, and that screen areas of varying sizes do not cause different brightness impressions. From this it was concluded that the optimum brightness level would be 14 ft-L with the improvement being gradual beyond 8 ft-L.

The German investigators further proposed that standardization would be incomplete without specification of the permissible drop of brightness with angle of view, since directional screens are becoming important.

A British survey examined visibility of grain, appearance of flicker and glare, and also tabulated specific comments on individual subjects and on the general quality of projection. From these data curves were prepared from which the Committee concluded that screen brightnesses should conform to the following:

Subject	Min.	Max.
Black-and-White ..	12 ft-L	24 ft-L
Technicolor	7 ft-L	14 ft-L

As a summary recommendation, the Committee proposed a minimum screen brightness of 8 ft-L and a maximum of 16 ft-L, and this has been adopted as British Standard 1404.

Further discussions have been published, but it does not seem that they offer any additional basic data suitable

for the further analysis of this particular problem. In many cases, however, they provide excellent summaries of the data available and of the practical application of the data, and of standards and recommendations.

Temporary Nature of Standard

In the report of the Projection Screen Brightness Committee in 1936, it was emphasized that their recommendation was for a tentative standard, to be modified as soon as practical: "It appears to the Committee . . . that the industry might stand to benefit by the adoption of a temporary screen-brightness standard. Logical limits for such a standard would appear to be 7 ft-L for the low value and 14 for the high value."

In its discussion, the Committee concluded that, on the other hand, an ideal standard "should be something of the order of 30 ft-L and that a peripheral brightness of the order of 0.05 ft-L is desirable at this brightness level. If such a brightness were obtainable, logical brightness limits would be 20 ft-L minimum and 45 ft-L maximal."

Having thus proposed a temporary standard, the Committee listed some of the questions which should be answered in order that the temporary standard might be replaced by an operating standard closer to the ideal range of screen brightness. These questions, promulgated in 1936, follow:

Basic Questions Posed

1. What correlation is there between best print contrast and screen brightness?
2. What effect does the brightness standard have upon the standard of release print qual-

ity? Shall release prints of different contrasts be made available to theaters operating at different screen-brightness levels? (Any work done on the standard release print must, for obvious reasons, consider the screen-brightness standard if it is adopted.)

3. Is highlight density, average density, density of the area of principal interest, or a combination of these factors, the thing that determines preferred brightness?

4. What possibilities are there for improvement in projection optics, pull-down efficiency, and source brilliance?

5. What is the effect of color of the light source, color of the screen, and color of the print upon the desired brightness?

6. What proportion of moving picture goes see pictures on screen greater than 20 ft, 25 ft, 30 ft? Statistical data on theater sizes, screen sizes, projection equipment and attendance figures are needed. A complete paper of this kind would be valuable also in connection with other problems confronting the Society.

7. What factors determine screen width? Would it not be better, for instance, to use a 25-ft screen at 9 ft-L than a 30-ft screen at 7 ft-L? The data of visual acuity tell us that the picture detail visible at great viewing distances should not suffer.

8. What are the possibilities for the development of simple, rugged, and inexpensive brightness-measuring instruments? Cannot a satisfactory simple brightness tester be developed with two fields, one at the higher and one at the lower brightness limit? Could not such an instrument be used easily by the theater projectionist to determine whether he is operating within the recommended brightness range?

9. What is the effect of auditorium illumination upon the required brightness level?

10. What is the effect of the visual angle or the screen size upon this value?

11. What tolerance in nonuniformity of

(Continued on page 24)

WESTREX FOREIGN MANAGERS, SPECIALISTS CONVENE IN NEW YORK



Representatives from all over the world are shown inspecting the new Westrex M4D re-recording and scoring console. Shown here, front row left to right, are E. S. Gregg, vice-president and general manager of Westrex; W. L. Bell (France); R. W. Wight (Hollywood); W. DeMello (Colombia); D. Pollock (South Africa); R. J. Engler (England); R. R. Abarbanel (Philippines); Second row: W. E. Kollmyer (India); J. Cuevas (Brazil); O. J. Forest (Trinidad, B. W. I.); M. Storms (Panama); S. Wiedemann (Switzerland); A. C. Leonel (Algeria).



TROUPER



TROUPERETTE

you'll meet

strong trouper high intensity arc spotlights everywhere..

SEE ANY OF THE FOLLOWING DEALERS OR USE COUPON FOR OBTAINING LITERATURE

- ALBANY, N. Y.—Nat'l Theatre Supply Co.; Albany Theatre Supply
- ATLANTA—Nat'l Theatre Supply Co.
- ATLANTIC CITY—Boardwalk Film Enterprises
- AUBURN, N. Y.—Auburn Theatre Equipment
- BALTIMORE—J. F. Dusman Co.; Nat'l Theatre Supply Co.
- BIRMINGHAM—The Queen Feature Service, Inc.
- BOSTON—J. Cifra, Inc.; Nat'l Theatre Supply Co.
- BUFFALO—Dion Products; Nat'l Theatre Supply Co.
- CHARLOTTE—Nat'l Theatre Supply Co.; Standard Theatre Supply Co.
- CHICAGO—Abbott Theatre Equip. Co.; Droll Theatre Supply Co.; Gardner Jansen, Inc.; Grand Stage Lighting Co.; Hollywood Stage Lighting Co.; Midwest Stage Lighting Co.; Nat'l Theatre Supply Co.
- CINCINNATI—Nat'l Theatre Supply Co.
- CLEVELAND—Nat'l Theatre Supply Co.
- DALLAS—Hardin Theatre Supply Co.; Modern Theatre Equip. Co.; Nat'l Theatre Supply Co.
- DENVER—Nat'l Theatre Supply Co.; Graham Bros.
- DES MOINES—Nat'l Theatre Supply Co.
- DETROIT—Nat'l Theatre Supply Co.
- FORTY FORT, PA.—V. M. Tate Theatre Supplies
- GREENSBORO, N. C.—Standard Theatre Supply Co.
- HOUSTON—Southwestern Theatre Equipment Co.
- INDIANAPOLIS—Nat'l Theatre Supply Co.
- KANSAS CITY, MO.—Shreve Theatre Supply; Nat'l Theatre Supply Co.
- LOS ANGELES—J. M. Boyd; C. J. Holzmuller; Nat'l Theatre Supply Co.; Pembrex Theatre Supply Corp.
- LOUISVILLE—Falls City Theatre Supply Co.
- MEMPHIS—Nat'l Theatre Supply Co.
- MILWAUKEE—Nat'l Theatre Supply Co.; R. Smith Co.
- MINNEAPOLIS—Minneapolis Theatre Supply; Nat'l Theatre Supply Co.
- NEW HAVEN—Nat'l Theatre Supply Co.
- NEW ORLEANS—Nat'l Theatre Supply Co.
- NEW YORK CITY—Nat'l Theatre Supply Co.
- NORFOLK—Nat'l Theatre Supply Co.
- OKLAHOMA CITY—Nat'l Theatre Supply Co.; Oklahoma Theatre Supply Co.; The Century Theatre Supply Co.
- PHILADELPHIA—Blumberg Bros.; Nat'l Theatre Supply Co.
- PITTSBURGH—Atlas Theatre Supply; Nat'l Theatre Supply Co.
- SALT LAKE CITY—Inter-Mountain Theatre Supply Co.
- SAN FRANCISCO—C. J. Holzmuller; Nat'l Theatre Supply Co.; W. G. Preddey Theatre Supplies
- SEATTLE—B. F. Shearer Co.; Nat'l Theatre Supply Co.
- SIOUX FALLS—American Theatre Supply Co.
- ST. LOUIS—City Electric Co.; Nat'l Theatre Supply Co.
- TOLEDO—Theatre Equipment Co.
- WESTERLY, R. I.—G. H. Payne Motion Picture Service
- CANADA—Dominion Sound Equipment, Ltd., Montreal, Quebec; General Theatre Supply Co., Toronto, Ontario; General Theatre Supply Co., St. John, N. B.; General Theatre Supply Co., Vancouver, B. C.; General Theatre Supply Co., Montreal, Quebec; General Theatre Supply Co., Winnipeg, Man.; Sharp's Theatre Supplies, Ltd., Calgary, Alta.; Perkins Electric Co., Ltd., Montreal, Quebec; Perkins Electric Co., Ltd., Toronto, Ontario.

Yes, you'll meet Strong Troupers everywhere—in theatres, arenas, auditoriums, hotels, ice shows and schools and colleges, wherever a sharp, dazzling snow-white spot is desired. A sharp, brilliant spot . . . quiet, flickerless, portable . . . is yours without the use of heavy rotating equipment when you use the Strong Trouper or Trouperette.

The Trouper High Intensity Arc Spotlight is ideal for theatres, auditoriums, arenas, hotels, ice shows, schools, colleges and lodges. It draws only 10 amperes from any 110-volt A.C. convenience outlet. An adjustable, self-regulating transformer is an integral part of the base. No heavy rotating equipment required. A two-element variable focal length lens system and silvered glass reflector account for much of the efficiency of this spotlight. It has an automatic arc control. A trim of carbons burns one hour and 20 minutes at 21 volts and 45 amperes. The Trouper is easily disassembled for shipping.

The Trouperette Incandescent Spotlight is particularly adapted to the needs of night clubs, small theatres and schools where physical dimensions and price are factors. As contrasted to conventional incandescent spotlights, with which the spot size is varied solely by iris, to result in substantial light loss, the Trouperette utilizes all the light through most of the spot sizes. This results in head spots which are 6½ times brighter. Sharp edges are maintained from head spot to flood. Features include a variable focal length objective lens system, 5¼" silvered glass reflector, Fresnel lens, fast operating color boomerang which accommodates six slides and a height adjustable mounting stand. The horizontal masking control can be angled at 45 degrees in each direction. The Trouperette uses a standard 115-Volt, 1,000-Watt prefocused projection type bulb and plugs into any 110-Volt convenience outlet.

THE STRONG ELECTRIC CORPORATION

"The World's Largest Manufacturer of Projection Arc Lamps"

14 CITY PARK AVENUE TOLEDO 2, OHIO

Please send free literature on the Strong Trouperette Incandescent Spotlight; Strong Trouper Arc Spotlight.

NAME _____
COMPANY _____
STREET _____
CITY & STATE _____

**FOR THEATRES
OUTSIDE U. S. A.
AND CANADA**



No one else serves the industry like Westrex!



**FOR STUDIOS
EVERYWHERE**

The complete theatre supply and service organization maintained by Westrex is the answer to every problem concerning equipment for theatres in 62 countries outside the U. S. A. and Canada. Offices in more than 100 cities are staffed with engineers trained by Westrex who have installed over 5000 Western Electric and Westrex Sound Systems. These trained engineers also service our systems plus hundreds of installations of other makes. Stocks of spare parts are maintained at all offices.

Each Westrex office also handles complete lines of associated theatre equipment and accessories—including

Century Projectors, Ashcraft Arc Lamps, Clancy Curtains and Controls, screens, projection lenses, ticket choppers, carbons, and ventilating equipment.

For studios throughout the world, Westrex offers a full line of Western Electric and Westrex studio recording equipment and accessories to meet every recording and re-recording need. These equipments—like Westrex Theatre Sound Systems—are the outcome of many years of research by Bell Telephone Laboratories and the Westrex Hollywood Laboratories.

Remember: No matter what you need, Westrex has it!

For Theatres outside U. S. A. and Canada

Westrex *Master, Advanced* and *Standard* Sound Systems all feature the Academy Award-winning Hydro Flutter Suppressor in their sound heads. There's nothing finer!

Amplifiers ranging from 15 to 100 watts output and Western Electric backstage speaker systems offer a choice to meet any theatre's needs.

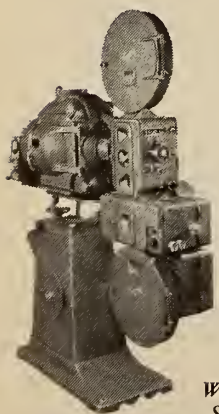

*Westrex Master
Sound System*

For Studios Everywhere

Westrex offers seven complete recording systems to record on photographic or magnetic film, 35mm or 16mm, variable area or variable density, direct-positive or negative-positive. The re-recorders offer a choice of 100 mil standard, 100 mil or 200 mil push-pull, 35mm or 16mm, photographic, or magnetic.

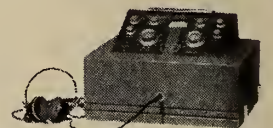

*Westrex Standard
Magnetic System*

Research, Distribution and Service for the Motion Picture Industry



Westrex Corporation

111 EIGHTH AVENUE, NEW YORK 11, N. Y.
HOLLYWOOD DIVISION: 6601 ROMAINE STREET, HOLLYWOOD 38, CAL.



The Allied Arts and Sciences

There is a vast field of artistic and scientific endeavor which is directly contributory to the motion picture process and, therefore, to the practice of projection. The true craftsman should have a well-rounded understanding of these contributory factors, particularly in view of the imminent widespread utilization of television and, possibly, stereoscopic pictures and stereophonic sound. To this end, IP here inaugurates a special department which will provide basic information on the aforementioned arts and sciences.

I. Photographic Optics

Bausch & Lomb Optical Company, Rochester, N. Y.

THE optics of photography is customarily looked upon as a subject too difficult for general consumption, and as a consequence the basic factor—the factor without which photography could be but a shadowgraph curiosity—is neglected and left to chance. No wonder, then, that a large mass of hoary misapprehensions has gathered about the optics of the processes.

Here we shall discuss two things—the general conditions underlying image formation, *i.e.*, what the lens designer must do to provide the photographer with good images, and second, practical characteristics of lenses.

We shall see that optics as applied to photography, particularly in its practical aspects, is not remote and theoretical, but built up step-by-step from common experience, and all that is necessary to understand the most essential facts of lens performance is a willingness to learn and an average endowment of common sense.

Meaning of a 'Good Image'

We must first establish in our minds some fundamentals: What is an image? What is meant by a *good* image? How good must an image be?

What is an image? To a physicist or an optician, an image formed by a lens system is the totality of reunion points of light rays emitted from the corresponding points on the object being imaged. Let us translate this statement into English more easily digested.

The object being imaged consists of an indefinite assembly of points each of which is emitting light in accordance with its brightness. To form an image of this object it is necessary to reunite into their corresponding points the light emitted from points of the object.

In this manner the points which are bright in the object will send out a

larger quantity of light, which will result in brighter image points, the less brilliant object points being more conservative of light and their corresponding image points likewise. Thus the lens establishes a one-to-one correspondence between object points and image points both for relative brightness and for general location.

Point-for-Point Representation

This, then, almost automatically gives us the conditions to be satisfied by the ideal image,—it must be an accurate point-for-point representation of the object with each part of the image in the proper relation to every other part of the image. Anything which hinders either the reunion of the light rays into points, or disturbs the relationship of the image parts, causes a departure from ideal imagery, and is spoken of as an aberration. A perfect image in the terms here used is never found, for we have been dealing with mathematical concepts, which are only idealizations, while we must live in a somewhat imperfect and practical world.

Because our senses are imperfect, and further, because of the grain in photographic emulsions, we find that we can use rather less than perfection in our lenses, thus making pictorial photography possible by creating depth of field.

Functional Test Fairest

Lest the preceding paragraph seem like a paradox, let us hasten to say that the only fair test of a product is a functional test. If a product satisfies the function for which it was intended, it has fulfilled its intention. Tests usually can be devised to show flaws in the best products. These tests are often artificial and always purposely hypercritical. Photographic lenses can be tested in the same manner.

But what difference does it make, if

the flaws seen in an artificial test are invisible in the camera? In other words, if your lens is performing satisfactorily and has given what seem to you to be perfect images, for your purposes you have the perfect lens, in spite of what will be said here. We should of necessity have to split hairs to show the aberrations, for some of them are of very small magnitude in modern lenses.

Because we are not dealing with mathematical perfection but with practical physics, we do not have to demand that our lens yield a mathematical point image. If a disc of about three one thousandths of an inch diameter were presented to the eye at 10 inches, it would be appreciated as a point. To all intents and purposes this disc would be a point, and we have no right to demand less diameter in our final prints.

This disc, of maximum size still perceived as a point, permits the depth of field so necessary to photography, and further allows reasonably satisfactory images from imperfect lenses. How this depth of field through finite image disc-points is accomplished will be seen farther along in our discussion.

The Pinhole Camera

The simplest camera is usually given consideration at the beginning of a discussion like this with good reason,—it teaches us much concerning the fundamentals of our subject. Parenthetically, the photographer's education is not complete until he has actually made and used a pinhole camera. It is easy to make, and instructions are readily found.

The principles of the pinhole camera are well illustrated in the diagram. Each point of the object emitting light which falls on the camera front creates, in effect, a shadow of that front on the emulsion. The only light actually getting through to the emulsion is that finding the pinhole. This light having come from a point is diverging, and will continue to diverge after passage through the hole, and by the time it reaches the emulsion it will have spread into a disc larger or smaller depending on the distance between the pinhole and the emulsion, and the size of the pinhole. This disc will then represent the point on the object from which the light originally came, *i.e.*, it will be the pinhole image of that point.

Image-Governing Factors

The collection of overlapping discs will be the image of the whole object. Pinhole imagery is largely pure geometry, as is the formation of images by means of lenses, the geometry being more clearly seen in the case of the former (Fig. 1).

The size of the *image* in a pinhole camera will depend on two factors, just

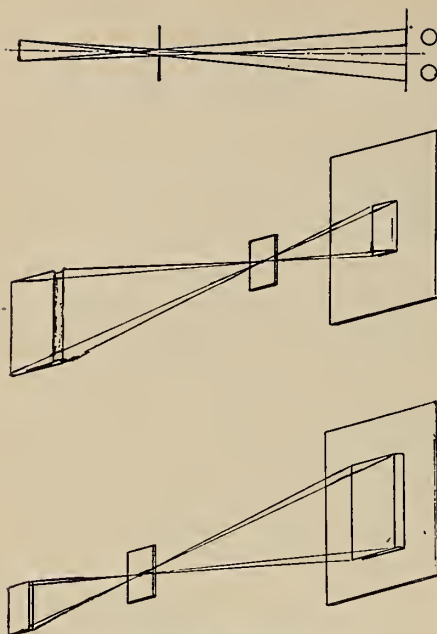

PINHOLE GEOMETRY
Top to bottom: Figs. 1, 2 and 3.

as in lens camera: the distance of the object, and the distance between the pinhole and the film (Figs. 2-3). The closer the pinhole and film, with a fixed object distance, the smaller the image, *i.e.*, the greater the reduction. The size of the image disc likewise depends in theory upon these factors; however, practically the only factor having effect is the distance between the hole and the film, since the object is usually at virtual infinity.

It is apparent that the size of the pinhole influences the size of the image disc, which we call the *circle of confusion* in accord with standard practice. The larger the pinhole, the larger the circle of confusion, and further, the more light falling on the film, that is, the "faster" the pinholes lens. In fact, the speed may be defined, just as in the case of a lens, by the ratio of the diameter of the hole to the distance from the hole to the screen, and the illumination on the screen will vary as the square of this ratio. (In practice the reciprocal of this ratio is used. It is used here in this manner for purposes of illustration.)

Pinhole Camera Attributes

The pinhole camera possesses several distinct advantages over cameras equipped with lenses: it is of universal focus; everything to infinity is focused on the emulsion; it will give a truly distortionless image, or in scientific language, an *orthoscopic* or "angle-true" image; it is the perfect wide-angle system, permitting the photography of angular fields practically unattainable with lenses; and, finally, it is so simple anyone can make and use it.

However, the pinhole camera is not

a panacea for ills photographic—it is extraordinarily slow compared even with the slowest of lenses, requiring extremely long exposure times; and most important of all, the image leaves something to be desired in the way of sharpness, as is to be expected. This softness of image is not always undesirable, however.

We have seen from the geometry of the pinhole camera that there is a focus of a sort at any separation of the hole from the film, but that the size of the image, *i.e.*, the magnification, is proportional to the distance, in addition to varying inversely with the object-to-pinhole distance.

Two Simple Explanations

The pinhole-to-film distance is the *focal length* of the camera. The focal length of the lens counterpart is defined as *the distance from the equivalent refracting point of the lens to the axial point where parallel rays of light are united.*

In the case of simple, thin lenses such as are used by optometrists, the focal length is closely equal to the distance from the lens to the focal point in parallel light. This, however, is not true for the more complicated lenses we must use in our cameras. The focal length, which determines the magnification, the stop number, and the angle of view of the lens with any particular film size is called "equivalent focal length," abbreviated E.F., and is perhaps the most important single characteristic distinguishing any one lens from the universe of all possible lenses.

It is found, when lenses become complex, that there are two points on the axis of the system, where equivalent thin lenses can be placed having the same refractive effect as the given system. With these *principal points* in a lens in air coincide a sort of generalized center of the complicated lens or lens system, the *nodal points* which have the property that a ray of light directed toward one will emerge from the other nodal point undeviated.

The E. F. of a Lens

The equivalent focal length of a lens is defined as the distance between the second or emergent principal point and the point on the optical axis where the lens unites a parallel beam of light. In most lenses the distance from the rear surface of the lens to this focal point will be less than the equivalent focal length. This distance is called the "*back focus*" and is the one really measured in a simple lens, where the second nodal point is very close to the lens surface (Fig. 4). In most lenses the nodal points are approximately at the center of the lens at the point where the diaphragm is found.

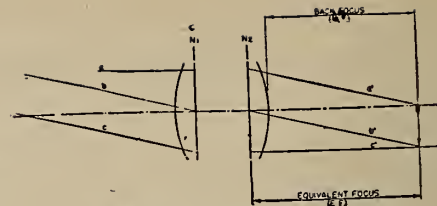

FIG. 4. The thick lens.

For many practical purposes, the diaphragm position (halfway through the shutter) may be looked on as the center of the lens, and equivalent focal length as the distance from the diaphragm to the emulsion when the lens is focused on infinity. The foregoing statements are true with any lens except a true telephoto, in which the principal points are actually outside the lens, in front.

Earlier we saw that the requirements for ideal image formation were that the rays leaving each point in the object be united in proper relation to the neighboring points. We further said that any disturbance of the orderly reunion of the light rays constituted an aberration. The most important aberrations are seven in number: five so-called third-order aberrations which are independent of color but whose magnitudes vary with different colors, and two pure chromatic aberrations.

Spherical Aberration Data

This is the only monochromatic aberration which can occur on the axis of a well-made lens. It has its origin in the fact that the margins of lenses made with all but certain strange mathematical surfaces have effectively more light bending, or refractive power than the regions near the axis, so that the marginal rays are brought to a focus closer to the lens than the near axial rays.

Surfaces which can bring all rays striking a lens to a common focus are weird mathematical creatures, impractical for the lens grinder to duplicate, and impossible in mass production as yet. The manufacturer prefers to work with spherical surfaces whose complete symmetry he uses to give him accurately reproducible surfaces, thus making possible quantity production of usable lenses.

As this particular aberration cannot be corrected in one lens, two of essentially opposing tendencies must be used to gain relief. We shall see more of the method of correction when we consider chromatic aberration.

Practical Effect of S. A.

Spherical aberration has the practical effect of laying a haze over the sharply defined image of axial points, and is equivalent to a diffusion disc before the lens. As a corollary of this, a lens with considerable spherical aberration will give a soft image, and indeed, some thirty years ago lenses with variable amounts of



FIG. 5. Spherical aberration.

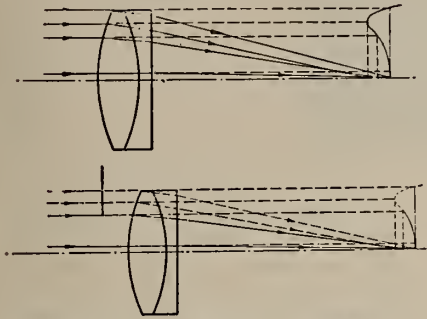

CORRECTION OF SPHERICAL ABERRATION.
Top to bottom: Figs. 6 and 7.

this aberration were sold as variable soft-focus lenses, and some may even be on the used lens markets today. A further consequence of this aberration is the greater depth of field and of focus, since no one plane is sharply defined (Fig. 5).

Spherical aberration cannot be perfectly corrected—the best that can ever be done is to bring to a common focus the axial rays and the rays passing through some other point on the lens diameter, usually near its periphery. This effects the best compromise correction, and is that most favored (Fig. 6).

This aberration is a function of the aperture of the lens, and will naturally be less, the smaller the stop used. Stopping down the lens will cut out the marginal and zonal rays, leaving the rays which normally would strike the axis closer together. The image would then appear to gain in crispness, while the depth of field increases (Fig. 7).

Spherical aberration is one of the more important of the aberrations, largely under the control of the designer, and usually reduced to a safe magnitude. However, there are lenses in which this aberration is left practically untouched for various reasons. If your lens gives crisp images with the film you normally use, rest assured that the maker has paid due respect to this troublesome aberration.

Coma: Most Important

This is the most important and most annoying single aberration of the whole battery afflicting lenses. Coma is the image destroyer which effects more ruin unaided than any other aberration. Photographic objectives otherwise perfect might have left in them each of the other aberrations singly and still be usable, but if uncorrected coma alone is present in an objective the lens is utterly worthless.

Coma affects only the points in the

field of the lens, *i.e.*, the extra axial points. In the presence of this aberration those points are drawn into unsymmetrical figures, causing an unsightly blurring of detail, and a loss of the possibility of recognition in extreme cases.

The nature of coma can be recognized from a consideration of the diagram (Fig. 8). The ray through the center of the lens is called the principal ray, and strikes the image plane at the point shown. In the presence of coma the rays through the outer zones of the lens do not strike the image plane at the same point as the principal ray. The discrepancies of these points measured in the image plane represent coma.

The actual image in pure coma is shown in the illustration. Each circle represents the locus of the foci of rays passing through a corresponding zone of the lens, the larger circles representing the outermost zones, and the vertex the principal ray. Actually the whole patch is not seen, for the figure shades off quite rapidly, and only the form shown in the figure is seen. Even so, it is readily apparent that this aberration deserves the attention given it.

Correction for Coma

Coma is corrected in lens systems by making suitable choice of the curves on the lens surfaces, technically by "bending" the lenses, *i.e.*, by changing the shape of the lenses.

Coma varies with the aperture in the same way as spherical aberration, and stopping the lens has the same effect. This is another reason for the adage, "stop the lens for sharpness." Coma further varies as the image height, which means that it will be worse near the margins of the picture. As the lens is stopped down, obviously light cannot pass through the outer zones and the corresponding image circles are missing, until, at the limit, when but one ray gets through, true point imagery is attained (Fig. 9).

Pure coma is exceedingly rare, and the comatic figures drawn are practically never seen, for this aberration is usually

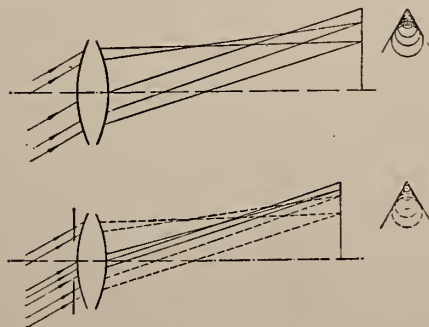

ILLUSTRATING COMA
Top to bottom: Figs. 8 and 9.

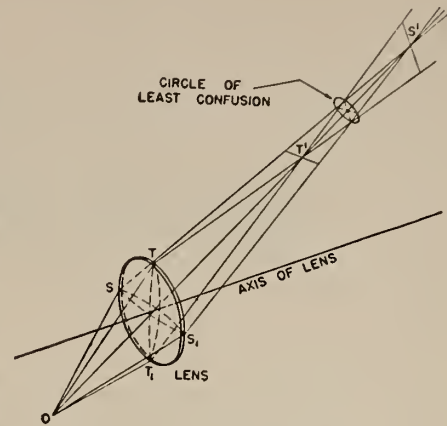

FIG. 10. Astigmatism.

seen together with astigmatism, which leads to peculiarly complicated figures.

Astigmatism: Separated Images

This is one of the strangest of the aberrations, for while the others govern either the shape or position of an image point, this one demonstrates two image positions as definitely separated image lines which are mutually perpendicular and perpendicular to the axis. In the presence of this aberration a point in the object gives rise to two separated images, lines at right angles. This particular aberration is rather frequently seen in photographs.

Better to comprehend this aberration, consider the drawing (Fig. 10). We saw that each point of the object reflects rays which strike the lens or lens system over its whole aperture: as far as the lens is concerned, each object point sends a cone of light to the objective sufficient to fill the clear aperture.

These rays upon reaching the lens cannot all be treated the same, for even in the case of an axial point the focus depends upon the incident height of the ray. Here, with an object point off the axis, the situation is even more complicated, for the rays in an oblique plane will find an effective surface curvature different from that in the plane at right angles. The result of this difference in curvature is astigmatism.

Tangential, Sagittal Planes

One plane, the one we normally consider in making drawings and in designing, the one containing the object, we call the *primary* or *meridional* plane, the "focus" of which gives sharp images of points lying on a circle whose center is the axis, and fuzzy images of radial lines. This particular focus is called the *tangential focus*, and the meridional plane alternatively as the *tangential plane*.

The plane perpendicular to this we call

(Continued on page 22)

IN THE SPOTLIGHT



By
**HARRY
SHERMAN**

A FAR-REACHING decision affecting the status of radio and television broadcasting studio employes was handed down recently by the National Labor Relations Board. The Board found that without modifying the unit description (stage electricians, stage carpenters, and stage property men, excluding all other employes and supervisors at station WNBT, New York, of the National Broadcasting Company), engineers or any other NBC employes, *irrespective of their job designations*, who regularly spend more than 50% of their time handling and placing Tv lights in the manner set forth in the decision in this case, *are in effect stage electricians* and belong in the unit for which the IATSE has been certified as exclusive bargaining representative.

On July 13 last, IATSE, NABET (National Association of Broadcasting Engineers and Technicians), and NBC filed a joint petition requesting the Board to clarify the unit description by indicating whether or not in its decision the Board intended the classification "stage electricians" to be limited *only* to those employes *bearing that title* on the NBC payroll; or whether the Board also intended that NBC employes, regardless of their job titles, who regularly spend more than 50% of their time in the handling and placing of Tv lights should be included in the unit. In its decision, the Board states, in part:

"Having reconsidered the record on which the decision in this case was based, we are convinced that this work can be and is effectively being accomplished by the *traditional stage electrician* of the stage and amusement world. When an engineer ceases to perform such work *as a mere incident* to his all-around engineering functions, but regularly takes on these duties as his *main operation*, he thereby forsakes his special field and assumes the character of a stage electrician."

- We are happy to report that Bill Covert, 2nd IA vice-president and business representative for Toronto Local 173, has licked a six-weeks stretch in the hospital and is now recuperating at home.

- We were saddened to learn of the sudden death several weeks ago of Julius J. (Chief) Schaefer, 62, member of Dallas Local 249. Schaefer was found lying on the floor of the projection room of the Palace Theater, where he had worked for the past 30 years, and it was at first thought that he succumbed to a heart at-

tack. However, upon his removal to the Parkland Hospital it was discovered that a skull fracture caused his death.

Schaefer was one of the original organizers of Local 249 and served as its president for more than a quarter of a century. In January, 1949, he was awarded a gold life membership card for his unswerving loyalty to the organization. He was a member of the American Federation of Labor for 44 years, of Dallas Masonic Lodge, Hella Temple, and of the American Legion. He was a veteran of World War I, having served overseas with our fighting forces.

He is survived by his widow and seven brothers—Henry, Rudolph, Ernest, Oscar, Conrad, Herman and Harry Schaefer, all of Cisco, Texas. Pallbearers at the funeral were Henry Long, Earl Holt, Clarence Holt, H. D. Hill, Charles A. Harcum, Paul W. Humphries, Fred Hanson, and Leon Saucier.

- We received a visit several weeks ago from Archie Stone, member since 1908 of Cleveland Local 160, and his son, Dr. Harry J. Stone. Father and son, and their respective families, were en route to Wrightsville Beach, N. C., where the doc-

tor was elected national senior vice-commander of the National Army and Navy Legion of Valor. Dr. Stone, who now makes his home in Ashland, Ky., was awarded the Distinguished Service Cross in World War II for "extraordinary heroism in action near Anzio, Italy." (See IP for July, 1944, p. 18.)

- The 66th annual convention of the Ohio State Federation of Labor was held in Columbus, Ohio, last month, with the Columbus Central Body acting as host to the delegates. Bob Greer, old-line member of Columbus Local 386 and president of the Body, extended a hearty welcome to the gathering.

- Pinch-hitting for the labor editor of the New York World-Telegram and Sun, who was on vacation, IA President Walsh was the guest columnist for Wednesday, August 29. His subject, of course, was the effect of Tv on the members of the Alliance and their ability to cope with this revolutionary development in the entertainment world. He outlined briefly the early history of the IA, telling of its struggles to gain a foothold as an organizing unit and how it overcame many obstacles on the road to its present high estate in Labor circles.

"The cooperative merit of show-business unionism again was demonstrated in 1919," wrote Walsh, "when stage employes played a large part in gaining recognition for Actors Equity in New York --and later when both stage employes and moving picture machine operators helped gain recognition for the studio mechanics in Hollywood.

"By today our services have been extended to virtually all film-studio technicians, as well as to front-of-the-house personnel at the theaters and employes at the home offices and regional exchanges of the film companies. . . .

"Now, for a fourth time, the horizon of show business is being pushed back. As before, we have good reason to believe we can take it in our stride—and are confident that the theater will continue to prosper, drawing sustenance from television and, in turn, helping to sustain it.

"In organizing television, we of the

Studio Blacksmiths in IA

If there be any Labor organization with more diversity of occupation among its members than the IA, we have yet to hear of it. For now we have as IA brothers—take a deep breath—blacksmiths! The IA recently won an election contest with the Blacksmiths' International to add to the IA roster the 25 blacksmiths in Hollywood studios. The vote was 17 to 3.

IA seek to avoid labor strife . . . we always bargain with patient firmness, and the completeness of our organization has made strikes largely unnecessary. Thus the industry has been stabilized. Today the skills of IA members are behind every network telecast. Quite a number of our veterans have entered this field, and we have enrolled many of its previously-unorganized workers. To others who find employment in the big expansion which lies ahead, our ranks are open."

• The recent promotion of Mike Yahr, for many years Chicago representative for RCA, to that of manager of sound products sales of the RCA Engineering Products Dept., came as no surprise to his many friends in the craft. Mike is highly regarded in the industry and he has the best wishes of his many IA friends for success in his new post.

• The 3rd District (New England) held its annual convention last month at the Hotel Statler, Boston, Mass. IA President Walsh addressed the gathering, outlining approved IA procedure in organizing independent radio and television stations. He suggested that the Local Unions take the necessary preliminary steps to lay the groundwork, and that a representative from the General Office be called in to close the negotiations.

Other speakers included General Sec. Treas. Raoul; Ass't IA Pres. Shea; Trustee Wm. Scanlan, and Benjamin J. Hull, Associate Commissioner of Labor for Mass. and member of Springfield Local 186. About 70 delegates, representing 60 Local Unions, were present at the meeting.

• We were sorry to hear that ill health forced the resignation of Matt Kennedy as business representative for Local 273, New Haven, Conn. Matt has represented the Local for the past 15 years and is very popular with his brother craftsmen.

• Many of the more progressive IA Locals Unions have working contracts covering 16-mm showings in their respective localities. The terms of these contracts vary somewhat, depending upon conditions prevailing in the different localities. George Schaffer, business representative for Los Angeles Local 150, recently sent us a copy of the Local's agreement with the Thorobred Photo Service of L. A., relative to the showing of 16-mm pictures at race tracks. Highlights of the agreement follow:

A. Projectionists employed full time shall receive \$132.50 per week, basic weekly salary, 8 hours per day, 5 days per week. All time over 8 hours in any one day shall be paid at the rate of \$4.97 per hour. All time worked over 5 days in any one week shall be paid at the rate of \$4.97 per hour for an 8-hour day.

Marty Bennett Heads Up RCA Theatre Sales

Martin F. Bennett, well-known RCA theatre sales representative in the Eastern Region, has been named Sales Manager of the Theatre Equipment Sales Section of RCA Engineering Products Department. Mr. Bennett succeeds J. F.



Marty Bennett, new head of RCA theater equipment sales

O'Brien, recently promoted to the post of Sales Manager of RCA's Theatre, Visual and Sound Section.

A native of Brooklyn, N. Y., Mr. Bennett has been active in theatre circles for more than 20 years. Prior to joining RCA in 1946, he served for 14 years with Warner Bros. Theatres as supervisor of sound projection in the New York area. He is active in the Society of Motion Picture and Television Engineers and the Variety Club, and served as President of the Warners Club for several years. He is a graduate of New York University and also attended St. Francis College.

An 8-hour day shall be worked within 8½ consecutive hours in any one day, with one-half hour lunch period.

B. Projectionists shall receive four percent (4%) of their total salary at the end of employment for vacation pay.

C. The PARTY OF THE FIRST PART (the employer) agrees that when desiring to dispose of the services of a projectionist furnished by the PARTY OF THE SECOND PART (IA Local Union), he will give the projectionist two weeks' notice, in writing, said notice to be considered as starting with the next payroll week; or two weeks' salary in lieu thereof, except in case of drunkenness, dishonesty, or incompetency, in which case notice will not be required. This notice may be waived by permission, in writing, from the PARTY OF THE SECOND PART.

D. PARTY OF THE SECOND PART agrees that all projectionists furnished by them who desire to leave the employment of the PARTY OF THE FIRST PART shall give the PARTY OF THE FIRST PART two weeks' notice, in writing, said notice to be considered as starting with the next payroll week. This notice may be waived by permission, in writing, of the PARTY OF THE SECOND PART.

E. The PARTY OF THE FIRST PART further agrees that in the event he dispenses with the services of any projectionist hired under this agreement, or said pro-

jectionist leaves the employment of the PARTY OF THE FIRST PART for any reason whatsoever, said PARTY OF THE FIRST PART will replace the employe leaving with another projectionist that is furnished by the PARTY OF THE SECOND PART.

F. Projectionists will not be requested or required to perform any act that is in violation of the terms of this agreement or the Constitution and By-Laws of the PARTY OF THE SECOND PART.

G. It is further mutually agreed that inasmuch as the PARTY OF THE SECOND PART is a member of the IATSE of the United States and Canada, nothing in this agreement shall ever be construed as interfering with any obligation the PARTY OF THE SECOND PART owes to such IATSE of the United States and Canada by reason of a prior obligation.

Schaffer advised us that copies of this agreement have been sent to all IA Locals in California, as a guide in future 16-mm negotiations.

• We regret having missed the visit of W. E. J. Rose, member of Local 91, Boise, Idaho, when he called at the IP offices recently. Rose and his family had just returned to the States after an extensive tour through several European countries. Another out-of-town visitor we failed to connect with was Walter Roberts, member of Local 178, Salisbury, N. C., who called for the second time in as many months—both times while we were out-of-town.

Safety Film in Mass. Suit

Contending that safety base film is less hazardous than common newspaper and that the application of the regulation concerning nitrate film should not apply when safety film is used, three Massachusetts theatres have filed an amendment to their suit seeking clarification of existing laws concerning the regulation of projection practices.

Amendment to the petition states that the laws applying to nitrate films should no longer apply to cellulose acetate or equally incombustible safety film.



From American Cinematographer

"Hello! A. S. C.? Send me two more cameramen—LEAN ONES!"

N.T.S. Observes 25th Birthday

NATIONAL THEATRE SUPPLY CO. observed its 25th anniversary early this month (Sept. 3). Pioneer nationwide distributor of motion picture theatre supplies, the NTS record has been embellished by a complete theatre service which has featured construction, re-modelling, and equipping theatres from roof to cellar, with the over-all operation being financed by the most liberal credit plans ever known in the theatre field.

Nor has the NTS operation been confined to the national scene: today its export department renders the same inclusive service to theatres and auditoriums in the far corners of the earth.

Technological Revolution in 1926

The natal year of N. T. S., 1926, saw the industry almost overwhelmed technologically by the sudden and furious onslaught of sound motion pictures. "Revolutionary" is the only truly de-



•
OSCAR
OLDKNOW
Vice-President
•

scriptive word to describe the abrupt change in both equipment and technique in America's motion picture theatres. Speed in both installing equipment and in training personnel was of the essence.

It was in this surcharged atmosphere that N. T. S. was launched, and it is one of the company's proudest boasts that events were taken in their stride and thousands of theatres equipped with a mass of new equipment without scarcely missing a show in the process.

N. T. S. headquarters were first established in Chicago, with Harry S. Dutton as president; while Walter E. Green and Oscar Oldknow were vice-presidents.

In an incredibly short time 31 branch offices were opened in the major film centers throughout the United States. Today there are 29 National branches in operation, the reduction of two being effected as a result of improved communications and speedier distribution methods.

Personnel With 'Know-How'

President of National today, and for the past 23 years, is Walter E. Green. The headquarters were removed in 1930 to New York at 92 Gold Street, where they have been ever since. Oscar Oldknow is now vice-president on the West Coast, he and Mr. Green being the only officers of the company who are members of National's 25-year club.

Other personnel who have been with National for 25 years or more are: A. T. Crawmer, Minneapolis; Louise Ferguson, Denver; N. C. Haefele, Baltimore; J. H. Kelley, Cincinnati; Bertha Kreinik, Buffalo; G. C. Lewis, Philadelphia; G. J. Libera and B. A. Benson, Warehouse; F. J. Masek, Cleveland; J. J. Morgan, Denver; Marion Oviatt, Kansas City; O. A. Peterson, Minneapolis; M. B. Smith, Los Angeles; and N. F. Williams, Pittsburgh.

N. T. S. now has an operating personnel of about 300 people, including 125 sales and service representatives. It would seem that the imminence of widespread theatre Tv will occasion further moves to strengthen and expand this or-



•
A. F. BALDWIN
Export Manager
•

ganization in this highly important respect. National is now serving more than 13,500 exhibitors throughout the



WALTER E. GREEN
President, National Theatre Supply Co.

United States, the theatres ranging in size from 200 seats all the way up to the gigantic Radio City Music Hall in New York.

Close Projectionist Ties

One of the cardinal principles of N. T. S. operation down through the

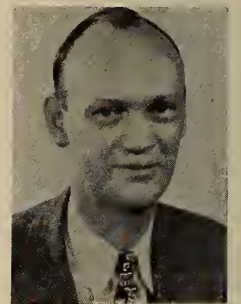

•
ARTHUR MEYER
Vice-President
in Charge of
Projector Dept.
•

years has been the extremely close ties it has established and maintained with projectionists, this policy being based on the belief that the man who uses the equipment is a vital factor in the uninterrupted smooth operation of the motion picture theatre. N. T. S. is always among the very first and the most liberal in support of all projectionist activities—a policy which has earned the company the gratitude and full cooperation of the craft. Particularly instrumental in the furtherance of this policy has been Arthur Meyer, who directs the projector—visual and sound—department of N. T. S. The name Meyer is practically synonymous with Simplex projectors.

Bases of Operating Policy

The list of products sold and installed by N. T. S. would fill this page and more, but it never ceases growing in order to effectuate National's promise to supply every bit of equipment for every type of theatre from cellar to roof—in addition to servicing all open-air amusement centers.

Exhibitors and projectionists—in fact.
(Continued Col. 1, next page)



J. W. SERVIES
Carpets and Purchasing



W. J. TURNBULL
Sales Promotion



J. E. CURRIE
Drive-Ins Theatres



A. J. LINDSLEY
Advertising Manager

Exhibitor-Producer Groups Meet to Spur Theater Tv

REPRESENTATIVES of exhibitor organizations meeting formally for the first time with the MPAA's (producers) Tv committee (Sept. 10) rung up progress toward a unified industry approach to the FCC on the allocation of exclusive Tv channels for theaters. One concrete result of the meeting was the designation of an engineering committee comprising engineers of the exhibitor groups, the MPAA, and several of its member companies.

Appointed to serve on the group, which will meet from time to time in advance of the FCC hearings on the pending application for channel allocations, were: Frank McIntosh, Andrew Ingles, MPAA; C. M. Jansky and Stuart Bailey, TOA; Earl I. Sponable, 20th-Fox; Paul Rabinow, Paramount; Frank Cahill, Jr., Warners; David W. Atcheley, Jr., United Paramount Theaters.

Vital Questions Posed

Among other things, the engineering committee is charged with coordinating the thinking of the organizations represented on the numerous technical problems involved in the Tv frequencies allocation move and the development of a theater Tv network. In the discussion these questions loomed large:

1. Should the size of the channels for theater Tv be eight or 10 megacycles? Color Tv is a factor here.
2. Is it desirable to rely for program transmission upon a private carrier or, instead, upon a "co-operative" carrier?
3. If a "co-operative carrier" is to be established, what financing will be entailed, and how will it be provided?

The latter, it was estimated, eventually could entail the expenditure of millions. However, the present plans are to develop network theater Tv gradually. Thus, in the presentation to the FCC the hook-up proposed will span the distance from Washington to Boston, taking in of course the cities in between. Admittedly, the problems arising are made the more difficult of solution because there are no precedents to go by.

While the FCC hearings are now set for Nov. 26, it was said that a further delay was not impossible. Thus, the hearings might be held sometime early in the new year. No date was set for the next joint meeting, but it was said that further parleys to hammer out a joint approach, mutually agreeable, would be held.

NTS Spots 35 Simplex Tv Units in Theaters in West & South

Sales of 35 Simplex theater Tv equipment within the past two months are reported by National Theatre Supply Co., distributors of the theater Tv equipment—both direct-projection and videofilm—manufactured by its affiliate, General Precision Laboratory. The orders include 23 direct-view and 12 videofilm equipments.

This report by National followed a series of special Tv "clinics" held through the South and West at which exhibitor reaction was described as "most enthusiastic." National is at present the only company offering both types of Theater Tv units.

The first Simplex large-screen theater

has launched and kept operating year after year many thousands of motion picture theatres, and which has done so on a basis of fine equipment, speedy and reliable service, and an over-all policy of fair and square dealing.

Tv equipment was installed in the Fulton Theatre, Pittsburgh, where it has been operating since last March.

Tv-Vaudeo Looms via Coaxial Unit in Capitol Theatre, N. Y.

Now it's Tv-vaudeo in the making. A. T. & T. has installed in the basement of Loew's Capitol Theatre on Broadway, N. Y., a coaxial cable junction. A. T. & T. sought and paid for the installation because of the Capitol's advantageous location as a central service point for theatre Tv to houses in the Times Square area.

Loew's executives see in the development the makings of a hookup which would enable them to stage a show at the Capitol and transmit it by direct wire to many chain outlets in innumerable cities.

Unlimited Program Possibilities

Possibilities of such a program are virtually unlimited. Under the setup, theatre audiences able to see top headliners would be the largest in history. At the same time, artists' salaries would zoom to unprecedented heights because of the huge audience in various cities. At the same time, commercially sponsored video would have to compete with theatre Tv for headliners, just as tele sponsors must vie with theatres in the showing of prize fights.

Problems to be met, once a theatre-vaudeo circuit is established, will be tremendous, as full development of this facet of the business will create a show business revolution. It's conceivable that a similar system can be used for transmission of legit plays, operas, etc.

The Capitol installation will also permit the house to receive direct wire transmissions from another theatre, studio or outside-inside location where a special event is staged, and thus can serve as a relay point to other theatres.

N.T.S. OBSERVES 25TH BIRTHDAY

all elements of the equipment branch of the industry—are expected to join in extending recognition during this 25th anniversary year to a company which

National Theatre Supply Branch Managers

R. J. MAURO—Albany
J. C. BROWN—Atlanta
A. C. HAEFELE—Baltimore
H. J. MCKINNEY—Boston
V. G. SANDFORD—Buffalo
R. D. TURNBULL—Charlotte
R. P. ROSSER—Chicago
J. H. KELLEY—Cincinnati
F. J. MASEK—Cleveland
R. L. BOSTWICK—Dallas
Memphis
J. B. STONE—Denver
A. C. SCHUYLER—Des Moines
C. B. WILLIAMSON—Detroit
B. N. PETERSON—Indianapolis

A. DE STEFANO—Kansas City
LLOYD C. OWNBEY—Los Angeles
A. J. LARSEN—Milwaukee
A. T. CRAWMER—Minneapolis
W. G. MILWAIN—New Haven
A. G. SMITH—New York
T. W. NEELY—New Orleans
J. I. WATKINS—Oklahoma City
G. K. SLIPPER—Omaha
W. J. HUTCHINS—Philadelphia
N. F. WILLIAMS—Pittsburgh
W. C. EARLE—St. Louis
H. H. RANDALL—San Francisco
O. L. CHINQUY—Seattle
Chicago Warehouse—
B. A. BENSON

New Rates Set for Tv Cameramen

The Association of Documentary and Television Film Cameramen has announced new wage scales, effective Aug. 15, as follows: cameramen, \$62.50 per day, \$225 week; soundmen, \$35 per day, \$150 per week; assistant soundmen, \$28 per day, \$120 per week.

Role of Photography in Tv

Photography's role in television is reviewed in the current issue of "Highlights," Eastman Kodak publication for stockholders. The article states, in part: "At least 30% of all Tv programs now on the air are on film (recent trade press

estimates even put the figure at 50%). This percentage, moreover, is rising as the advantages and methods of using films become better known.

"For 1951 Tv will use an estimated 300 to 350 million feet of film. Most of this will be black-and-white, 16-mm motion picture film; the rest 35-mm." Discussing the usefulness of film in television, the article states: "Film enables producers to make some programs . . . that would be next to impossible to do 'live.' . . . Again, film can be slowly and carefully edited—'on the air' pressure is absent. There are no 'flubbed' lines. Special effects, like animated cartoons, can be created.

"Films can be used repeatedly. In this way the cost of a show can be spread out over more air time and more sponsors. Larger audiences can be reached—a film show can be projected at the best time for advertising regardless of time zones. Interestingly, a number of producers are already shooting Tv films in color. These are printed on black-and-white film for screening now. But, when needed, they'll be ready for use again on color telecasts."

Tv Greater Threat to Mags

News and picture magazines which are prematurely burying the motion picture industry as a victim of television are more likely to supply the corpse. Allied's general counsel, A. F. Myers, warned. Myers had reference to a recent story in *Life* magazine, based upon a survey in which interviewers were shown agreed that Tv will kill off the movies.

"Weekly news magazines, like *Life* and its stablemate *Time*, have a lot more to fear from Tv than the movies," said Myers, reminding that "Tv's great contribution is the instantaneous transmission of important and interesting events by sight and sound. As an art medium, even as an entertainment medium, Tv has limitations which cannot be overcome. It can never be more than a parlor peep show or animated billboard. But as a medium for the instantaneous depiction of great events, it has no rival."

Marconi's Famous 'Why?'

Hitherto unpublished correspondence of Guglielmo Marconi has been incorporated in a new booklet written by Orrin E. Dunlap, Jr., vice president of RCA. Unfolded here is story of Marconi's yearning to learn the mysterious cause of the great invention he fathered.

"Indeed, the 'why' of radio continually challenged Marconi," Mr. Dunlap writes. "After a night of vigil in long-distance test of wireless between the English Channel and Australia, he turned to a friend on board the *Elettra* (Marconi's yacht) and with a perplexed expression remarked:

"There is one thing I would like to know before I die—why this thing works!"



To the Editor of IP:

I have read the articles on "The Magic of Color," by Robert A. Mitchell, with great interest. There is one point in Mr. Mitchell's treatment of the subject which I should like to correct—namely, where he refers to me as "inventor" of Technicolor. Actually, the Technicolor process was not invented by any one man but by a group of men; and no doubt Mr. Mitchell intended to convey that I was one of the group of which I have functioned as Director and General Manager from the outset.

HERBERT T. KALMUS

President, Technicolor
Motion Picture Corp.

To the Editor of IP:

I read with great interest the article on film damage in IP for July ("Seven-Year Survey of Film Print Damage," p. 12) and I am wondering whether similar surveys have been made covering 35-mm film.

Film exchanges keep booking records, but they do not seem to tabulate the number of runs during a single booking, a figure that would be needed in any accurate evaluation of film life. From time to time replacement footage is inserted in features of recent release, particularly the so-called big pictures, but the data on such replacements, other than that required to order the footage from the laboratory, is sketchy.

I believe that it would be interesting to have such information on 35-mm film recorded and published.

L. F. ADAMS

Beverly Hills, California

[Inquiries by IP reveal that no such data in the form outlined by Mr. Adams is available. Such a project would certainly be very much worth-while, particularly in view of the present critical shortage of film stock. IP is exploring the topic further and hopes to be able to present such data in the near future.—Ed.]

To the Editor of IP:

I am extremely interested in your excellent magazine which is contributing highly thought-provoking articles in the field of motion picture and sound projection. Unfortunately, we here do not enjoy the many facilities available to your people—magazines, books, laboratories, etc. I have received your magazine for the past three years, but we have missed many fine articles in past issues which are now unavailable.

I am particularly interested in data

on drive transmission and on sound picture equipment circuits. Shortly I shall send to you the prospectus of our course.

M. RAM MURTHY

Instructor, Sound Dept.,
S. I. Occupational Institute,
Bangalore, South India

To the Editor of IP:

Will you please kindly teach us the competent authorities for motion picture theater projectionists as followed in the United States? In Japan, the Ministry of Labour and the fire-brigade are both the competent authorities in such matters.

Also, we should like it very much if you could send us samples of the questions asked in the United States.

TOSHIO MIYAMOTO

Manager, Shinkoiwa Theatre,
Tokyo, Japan

[Every possible assistance will be rendered to these advocates of better projection in foreign lands. It would seem that the examination of projectionists in Japan does not differ in the main from the pattern established in the U. S. A. Here are two standout examples of people who are thirsty for information, so readily available, that we in America so blithely gloss over or, worse, ignore.—Ed.]

To the Editor of IP:

Having resurfaced hundreds of motion picture screens, I have become convinced that the weakest link in the projection chain is the screen itself. Deterioration takes place slowly, insidiously, and is often not noticeable to the exhibitor and the projectionist who view the surface daily.

Checking screen efficiency is a simple matter: go on stage and switch on the footlights or the border lights; if such lights are not available, use a 150-watt flood- or spotlight. Take a freshly laundered handkerchief and hold it against the screen. The contrast is amazing!

A new screen is, of course, the best solution. But lacking this, resurfacing, which is 90% effective, is the answer. A simple process, resurfacing can be done by anybody—provided a special paint properly compounded is used. A diffusive-type paint and a highly reflective surface are "musts." Our product, Arctic Blanch, can be applied successfully by anyone familiar with the operation of a spray-gun. Use 40 pounds pressure, which is enough to go through the sound perforations without occasioning clogging.

A large majority of screens are in a

deplorable condition: they cause eye-strain which induces a headache—for the patron and for the box-office. This situation is right down the projectionist's alley, and he should be on his toes to check and advise management as to the condition of the screen.

KEN CLADWELL

National Screen Refinishing,
Buffalo, N. Y.

To the Editor of IP:

I should appreciate it if you would give me a simple explanation of the term "peak inverse voltage," particularly as applied to rectifiers.

HERBERT R. SALTER

Los Angeles, Calif.

[In rectifier terminology, inverse voltage is that voltage which is applied across the rectifier (and which the rectifier must be able to withstand) when the applied A.C. voltage is passing through its negative half-cycle and the rectifier is not conducting. Peak inverse voltage is the maximum value of voltage which is applied to the rectifier unit under these circumstances.

If the peak inverse voltage is too high, the rectifier may be damaged by breakdown. For this reason, the peak inverse voltage rating is an important rectifier characteristic which must not be neglected by designers and users of power supply equipment.

The magnitude of the peak inverse voltage depends upon the nature of the rectifier load circuit, as well as upon the type of rectifier circuit and the applied A.C. and output D.C. voltages.—Ed.]

Carbon Drippings Collection

The copper dripping salvage program, initiated last month, is well under way, according to Nathan D. Golden, of the NPA. Communications from the various trade and union associations participating in the program indicate a high degree of cooperation on the part of all segments of the industry.

Marc J. Wolf, Chief Barker of Variety Clubs International, has charged the Chairman of the Welfare Committee of each Tent with the responsibility of supervising the operations of the program in each film distributing territory. In the point-by-point instructions, it was emphasized that the basic responsibility for the collection of such copper drippings from theaters was in the hands of a designated group of theater equipment dealers in each film distributing city. The instructions also provided that all theater equipment dealers in every city would cooperate in the program.

Procedure for Disposal

In general, it was provided that any theater equipment dealer in the country who received copper drippings from theaters would either transfer such drippings to the designated theater equipment

dealer in his city, or would arrange with the local Variety Club Welfare Committee to sell the drippings which he collects to a suitable metal scrap dealer. The proceeds from such sales go to the Welfare Fund of the local Variety Club.

This entire copper dripping program is an industry-wide effort and every segment in the industry is being asked to cooperate to the greatest extent possible.

Delay in Filing CMP Forms; Oct. 1 Absolute Deadline

Although the Controlled Materials Plan providing for the allotment of specific quantities of iron, steel, copper and aluminum was introduced by the NPA July 1, 1951, it will become fully effective during the fourth quarter of this year. Commencing October 1, 1951, manufacturers will find it virtually impossible to obtain suitable quantities of controlled materials without CMP allotments. At the same time, they will require a priority rating for the procurement of non-controlled materials and components.

Some Manufacturers Lax

All manufacturers were instructed to file fourth quarter CMP-4B applications for controlled materials with their Industry Division of NPA during the month of July. A considerable number of manufacturers who filed third quarter applications have so far failed to file their fourth quarter applications, as instructed. NPA applications for controlled materials for the first quarter of 1952 must be filed before October 1, 1951.

Manufacturers are reminded of the fact that they should file only one CMP-4B application under each product code for their requirements. However, where the production of repair and replacement parts are separately scheduled, the requirements for such parts must be incorporated into a separate CMP-4B application.

Model 9 Ballantyne Soundhead

Simplicity in design and operation, plus an extremely low flutter level, marks the new Ballantyne Model 9 soundhead which has just been put into operation in theaters. Flutter in the Model 9 is more than 50% less than the accepted Academy minimum: the Academy standard is 0.15%, while the Model 8 has a rating of from 0.02 to 0.08%.

The complete gear box and film drive assembly of the Model 9 is removable as a unit from the front side of the head, making for extremely simple servicing. The gear box itself is of the worm gear type, designed for at least ten times actual operating load. The constant speed sprocket is driven by a large bronze worm gear and loaded to provide smooth

NEW BALLANTYNE SOUNDHEAD

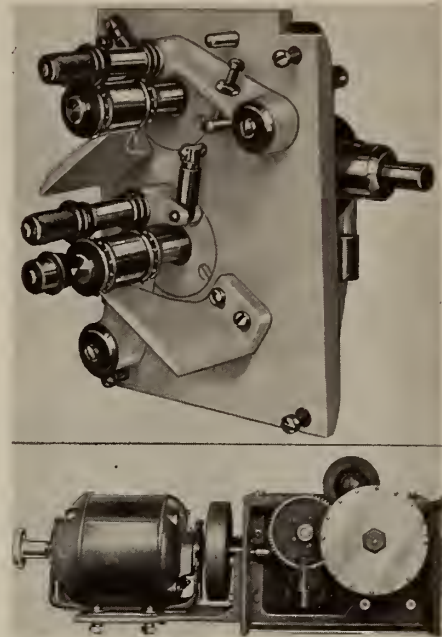

Top: entire upper and lower sprocket assembly in gear box removed as a unit from operating side. Pad roller assembly is held in place by a new compression-type coil spring lock.

Bottom: simplified gear drive and perfectly balanced, ball bearing-mounted, oil-damped filter, with flywheel and case machined from solid steel bar stocks. Note motor handwheel for easy threading and adjustable motor mount. Two simple gears drive entire projector. Gears and pinions are key-mounted on shafts, and entire gear box is factory-sealed.

operation. All shafts are ball bearing-supported and have individual oil seals. The sprocket assembly has positive action compression-type coil-spring locks with adjustable stops for positioning pad rollers.

The scanning drum and shaft rotate on lifetime sealed ball bearings and are ground as one unit to a tolerance of plus or minus .0002. The filter flywheel is perfectly balanced, ball bearing-mounted, oil-damped, with the flywheel and the flywheel case machined from solid steel bar stock for perfect balance. The case is impervious to oil.

West Coast RCA 16-mm Distributor

Coast Visual Education Co. has been named distributor for RCA 16-mm sound-film projection equipment serving the metropolitan Los Angeles area. Formed in 1944, CVE (A. Paul Cox, Robert C. Thomas, and Bill Utz) will sell and service all RCA audiovisual products, the service department personnel having been factory-trained by RCA.

CVE has modern sales-rooms and service and warehousing facilities, including 4500 square feet of floor space, at 5620 Hollywood Blvd., Los Angeles.

PHOTOGRAPHIC OPTICS

(Continued from page 15)

the *sagittal plane*. It is the plane which, in the normal optical drawing, lies perpendicular to the paper and cannot be drawn except in perspective. This plane gives sharp images of points lying along lines intersecting the optical axis, and because the effective curvature in the sagittal section is different from that in the meridional section, this focus is at a different position along the axis, *i.e.*, the sagittal focal plane is displaced from the tangential.

Thus in the presence of astigmatism

an extra axial point gives rise to two approximations to an image: (1) a constriction in the bundle of rays which takes the form of a short line in the plane of the axis and the object point, and (2) a short line perpendicular to and separated from the former. These are the sagittal (or radial) and tangential image lines, respectively.

Occupy Different Planes

These images will occupy different planes, the distance between them constituting the astigmatic difference, this being one important aspect of astigmatism. The other aspect of this aberration

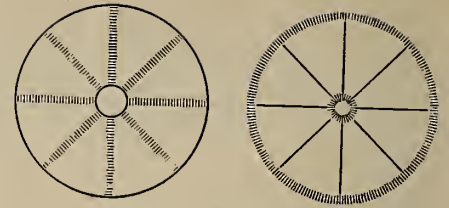

FIG. 11. Astigmatism.

is the length of the astigmatic lines, which we shall consider briefly later.

Conventional Astigmatism Example

This aberration is usually explained in terms of the image of a spoked wheel with hub on the lens axis (Fig. 11). The spokes constitute radial or sagittal objects and are sharply imaged in the sagittal image plane, where the rim, a tangential object, is out of focus. The rim would be imaged sharply in the tangential image plane, where the spokes are out of focus. To find an approximately satisfactory focus for both simultaneously, it would be necessary to put the focusing screen or the emulsion midway between them at the position where the two focal lines degenerate into a disc, the circle of least confusion.

This disc represents the best compromise focus, and is easily seen to have a size determined by the length of these lines. The longer the lines, the larger is the circle of least confusion, and the less sharp the image.

Astigmatism is often noticed in photographs as a peculiar streakedness, usually tangential, in a background comprised of an assembly of small areas, such as leaves and their interstitial spaces. In this case the tangential focus at that point in the field is closer to the emulsion than the sagittal, and the background points are imaged as the appropriate astigmatic lines.

Points on the Axis

It will be noticed that here we have been considering the astigmatism of points in the field, *i.e.*, points off the axis of the lens. For points on the axis there is no astigmatism of the kind here considered, for there no difference of effective surface curvatures can exist in a symmetric system.

However, if some of the lenses are decentered, or more particularly, if there is an asymmetric component to the surface curvature as would be provided by a cylindrical surface, then, even on the axis, two mutually perpendicular separated focal lines would exist, and axial astigmatism would occur.

This state does not usually exist in photographic lenses except for very special purposes. This is the type of lens provided to correct the astigmatism of the eye.

The lens designer finds that he can

Theatre TV

Demands Experience and Specialists

—RCA SERVICE

has both



Only from RCA Service do you get the *experience* that comes from installing and maintaining more theatre TV systems than any other service organization—anywhere. Only from RCA Service do you get *specialists* trained in the television laboratories and factories of the pioneer in theatre TV.

4 ways RCA SERVICE can help you

- 1 **Survey and help** solve the special TV application problems relating to your theatre.
- 2 **Supervise** the installation, adjustment and testing of all video equipment, coaxial lines and antennas.
- 3 **Give instruction** and technical advice to your projection personnel in the efficient operation of the equipment.
- 4 **Make periodic inspection** checkups . . . furnish replacement parts and tubes . . . supply emergency service—to forestall trouble, extend equipment life, keep repair costs down.

It costs so little to protect so much

And nowhere else do you get such *specialized* theatre TV service. Write for complete information.



RCA SERVICE COMPANY, INC.
 A RADIO CORPORATION of AMERICA SUBSIDIARY
 CAMDEN, NEW JERSEY

control astigmatism most effectively by means of varying the distribution of power among the components and uses this means to correct for astigmatism in

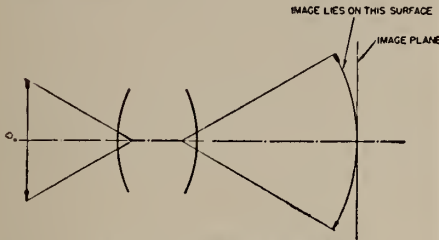

FIG. 12. Field curvature.

connection with the closely related Petzval curvature to be considered in the next section.

In practice, it is found that the astigmatic difference of focus is independent of the aperture, that is, that the stop has no influence on the positions of the tangential and sagittal foci. However, the lengths of the lines do vary directly with the stop. Thus stopping the lens has the advantage of shortening the lines, making the circle of least confusion smaller, and making the image more crisp.

Both the focal difference and length of lines vary sharply with image height, and, as in coma, become more serious near the margins of the field.

Petzval Curvature of a Lens

Even in a lens whose astigmatism is brought to zero, the image will be found not to line on a plane perpendicular to the axis, but on a spherical surface (Fig. 12). Here the image is sharp.

It is unfortunate that the film surface cannot be made to conform to a sphere, for the lensmaker's problems would be simplified. As it is, in the presence of field curvature, and with a flat filmplane, a compromise setting must be used (Fig. 13). The maker is to be congratulated on the high quality he achieves under such handicaps.

Petzval curvature is inherent in any lens, and can be looked on partly as a natural consequence of the fact that objects on the axis of a lens are closer to it than objects in the field, and thus will be imaged farther from the nodal points than objects occurring a distance from the axis.

Looked at in another way, to achieve a flat image of naturally occurring ob-

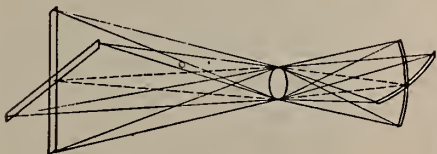

FIG. 13. Field curvature.

jects it is necessary that the lens or objective have different effective "focal lengths" in the margins and corners of the field than at the center, for other-



when you use
SUPER-SNAPLITE

f/1.9 projection lenses

Yes "MOVIES ARE BETTER" and they're "BETTER THAN EVER" if you use Super Snaplite f/1.9 Projection Lenses. These superb lenses give you maximum light, maximum sharpness, and maximum contrast . . . maximum viewing satisfaction for your patrons.

True speed of f/1.9 in every focal length up to 7 inches. Ask for Bulletins 207 and 209.



"You Get More Light with Super Snaplite"

KOLLMORGEN
2 Franklin Avenue
Brooklyn 11, New York
Optical CORPORATION

wise the sharp image would be formed on the surface of a sphere whose radius is the equivalent focal length.

The degree with which the effective focal lengths become longer as the margins of the field are approached is the measure of the success of the lens designer in removing or ameliorating this particular stubborn aberration. The field

curvature is a function of the type of glass used in the objective components, and further is influenced by the particular distributions of power among those components. By suitably choosing and/or altering these variables, the designer can reduce the Petzval curvature to a tolerable amount.

[TO BE CONTINUED]

Conditions of Experimentation

The conference agreed that any work pertinent to the determination of optimum theater viewing conditions must simulate very closely the actual theater viewing. O'Brien and Evans warned particularly against inferring from the measurement of fundamental visual functions the result under theater viewing conditions. The knowledge of vision and the contribution of the visual functions to the total task of viewing are insufficiently understood.

In suggesting and sponsoring research on theater viewing the Committee will be asked to indicate what scope of variables should be included. In the conference discussion, it seemed obvious that the viewing conditions must include the full range of present indoor and outdoor theaters when projecting motion pictures. It is probable that it should include also the range of projected theater television.

Committee-Sponsored Research

Furthermore, research sponsored by the Committee should aim to determine optimum viewing conditions regardless of their practicability. The research moreover should determine what compromises with this optimum can be made with the least sacrifice of picture qual-

ESTABLISHING THE BRIGHTNESS OF MOVIE SCREENS

(Continued from page 10)

screen brightness from center to edge should be established?

Little Recent Progress

None at the discussion reported herein could recall that any work specifically pertinent to the determination of a standard of screen brightness or to the conditions of theater viewing had been accomplished in the interval since 1936. O'Brien reported that the visual work since that time has been so fundamental in nature or directed to such different ends that its interpretation for the setting of theater viewing conditions might be extremely difficult.

The conference thought that the list of questions proposed by the Commit-

tee in 1936 was as adequate now as it had been at that time, that little progress has been made toward a direct answer to any of the questions, and that any such answer would result only from studies purposely designed to investigate the desirable brightness of projected pictures.

It was the consensus that a great deal of work could be done toward determining optimum conditions of theater viewing and that it would be worth while for the Screen Brightness Committee to sponsor such a research program. It was also felt that it should not be too difficult to outline experiments and to formulate a program which would take sufficient account of the difficulties involved to make a real contribution, and to be free of many of the criticisms leveled at early work on screen brightness.

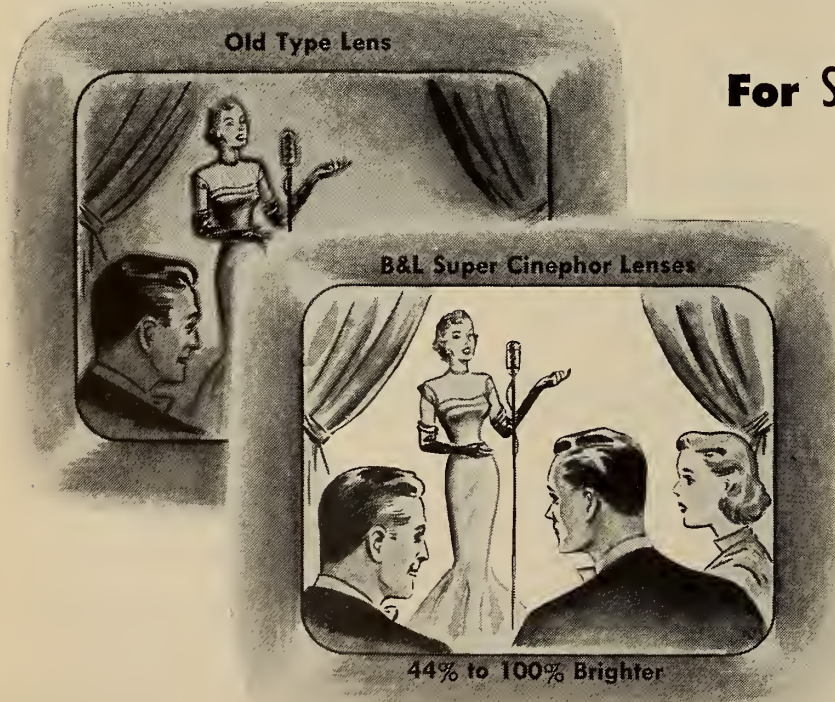

For STEADY PROFITS you need

TODAY'S FINEST SCREEN IMAGE

Replace **NOW** with B&L Super Cinephor Lenses . . .
for Steady Patronage

Keep your patrons coming back! Don't let dim, eye-straining screen images cut profits. Show today's sharpest, brightest pictures . . . *edge-to-edge* brilliance and contrast . . . with B&L Super Cinephor lenses.



Write for complete information to Bausch & Lomb Optical Co.,
616-11 St. Paul Street, Rochester 2, N. Y.



Bausch & Lomb

Super Cinephor Projection Lenses

ity. The program should thus serve to indicate the goal toward which development of motion picture projection should proceed and should also indicate what temporary compromises with that objective can be made most justifiably.

Evans noted the corollary position of the various Tv committees which have been searching for data in this same field. If their research covered all Tv viewing, while the Screen Brightness Committee considered motion picture viewing, the data for the two fields would be complementary. For example, theater viewing probably covers the range of viewing distances from 1½ to 6 screen widths; while Tv viewing begins at 6-7 screen widths and continues to greater distances.

Significant Viewing Variables

Most important to the outlining of a proper research program, the discussion felt, was a tabulation of significant variables in theater viewing so that proper account could be taken in setting up experiments. The conference enumerated the following variables as definitely significant: (1) screen brightness; (2) surround brightness; (3) conditioning level of illumination; (4) viewing angle; (5) viewing distance; and (6) subject matter of test pictures.

A primary contribution of the meeting was a discussion of these variables; the discussion has been taken out of its temporal sequence and here organized by subject.

1. SCREEN BRIGHTNESS

Sensitivity of the observer to brightness changes was discussed, with Lozier and Chambers feeling that equal percentage changes in illumination are more visible at the lower brightness levels; for example at 2 ft-L a 100% increase in brightness appears more effective than a 100% increase at a level of 15 ft-L. Newhall suggested that the magnitude of such perception of brightness change is influenced greatly by the conditioning level of illumination preceding the test.

Color of the illuminant used during the test is important; Chambers reported that *the optimum level chosen under incandescent illumination has been found to be different from that chosen under arc illumination*, and that in particular the apparent contrast of a picture appears higher with arc quality illumination. Evans agreed that the apparent

Still The One in '51

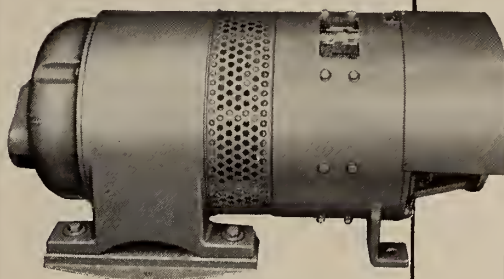

TYPE "HS" TRANSVERTER

After 50 Years Of Leadership

The Hertner TransVerteR

REG. U. S. PAT. OFF.

For Unexcelled
Performance in

DELUXE THEATRES
SMALLER THEATRES
DRIVE-IN THEATRES
AUDITORIUMS

IMMEDIATE DELIVERY OF ALL STANDARD SIZES

6 TYPES

Hertner Transverters are made in six types, for theatres of all sizes:

TYPE "LV" for Simplex HIGH 1 KW Arcs

TYPE "HI" for Suprex Type Arcs

TYPE "HIH" for Suprex and Spot Arcs

TYPE "HS" for 50-63 Volt High Intensity and Spot Arcs (for National Excelite 55,000 type lamp)

TYPE "MA" for 50-70 Volt Low and High Intensity Arcs

TYPE "CP" for 60-75 Volt High Intensity Arcs

PLUS FEATURES

- Velvet-smooth power—no AC ripple
- Cool, quiet performance
- Safe, slow operating speed
- Economical, long-life, trouble-free operation
- Modernized, compact, horizontal design
- Proved experience since 1901
- Sealed-for-life ball bearings
- Designed for specific power supply of each installation
- Easily adjusted ballast rheostats

Distributed by
NATIONAL THEATRE SUPPLY

In Canada: GENERAL THEATRE SUPPLY COMPANY



THE HERTNER ELECTRIC COMPANY

12690 ELMWOOD AVE. • CLEVELAND 11, OHIO
A General Precision Equipment Corporation Subsidiary

MOTORS • MOTOR GENERATORS • GENERATOR SETS

BUY U. S. SAVINGS BONDS

Your Very Best Buy

BUY U. S. SAVINGS BONDS

contrast of the image varies considerably with the color of the illuminant.

Flicker inherent in the intermittent projection of motion pictures was discussed from two viewpoints: (1) the proper integration of an intermittently illuminated image, and (2) the perception of flicker as a distracting influence. The discussers felt that the indications of meters and measuring devices used to correlate work on screen brightness must be such as to have a response to intermittent illumination consistent with the response of the human eye.

With reference to the level at which

flicker becomes distracting, Lozier reported observations indicating that flicker is objectionable above 15-20 ft-L. O'Brien, on the other hand, found no objectionable flicker in his experiment at levels up to 30 ft-L. Evans noted that while the threshold for foveal flicker is not exceeded by 48-cycle illumination at 30 ft-L, on the other hand the threshold for peripheral flicker at that intensity is well above 48 cycles.

Peripheral flicker begins to be observed at 48 cycles in the range of 15 ft-L. Thus, the sensitivity to flicker and the effect of flicker as a disturbing influence will be a function of viewing angle, decreasing as the viewing angle is decreased and as the vision becomes more nearly limited to the foveal region.

2. SURROUND BRIGHTNESS

O'Brien reported that in his opinion if his earlier research had made any single contribution it was to indicate that some definite surround brightness is desirable in the viewing of motion pictures, and that under normal theater conditions a surround brightness of approximately 0.05 ft-L is preferred by observers free to choose.

Spragg reported that wartime research on radar-screen viewing showed signifi-

cantly better performance of the observer with a definite surround brightness. There was less fatigue, better perception of detail, and quicker response to the image, as the surround brightness was progressively increased up to levels nearly equal to the screen brightness itself.

Evans pointed out that—entirely apart from the fatigue, ease, and pleasure of viewing—the surround-brightness level changes the appearance of the picture as the surround brightness is increased from zero up to the highlight brightness, the illusion changes from that of viewing a projected picture to that of viewing a print.

Consequently, one factor influencing surround brightness is the determination of which viewing effect is desired and what criterion of desirability is chosen. Some of the newest theaters, Evans noted, are being so built as to use



**Think of the
BIG MONEY
you can save!**

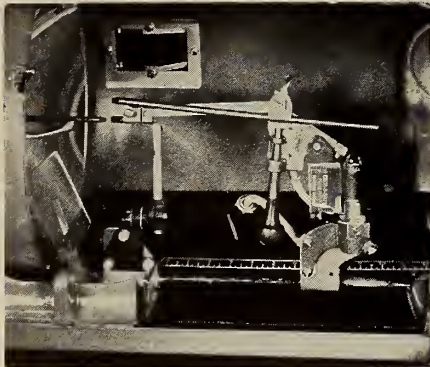

The wasteful practice of throwing away carbon stubs can unnecessarily cost you thousands of dollars.

THE CRON-O-MATIC Fully Automatic CARBON SAVER

uses stubs of all lengths without any preparation. It's no longer necessary to guess whether or not a carbon stub will burn a full reel. Simply insert in the holder. When it is entirely consumed, the new carbon goes into use without losing the light. The Cron-O-Matic in no way interferes with the regular operation of the lamp.

Adaptable to Ashcraft "D", Brenkert-Enarc, Peerless Magnarc and Strong Mogul lamps. Only \$52.50.

PAYS FOR ITSELF 3 TIMES A YEAR!

Burns positive carbon stubs, which usually average 3/4" in length, down to a constant length of 3/8", to result in a net savings of 2 1/2" per carbon or 22.2% of the cost of the carbon, which for the average theatre actually amounts to \$150.00 per month . . . every month!

If your theatre equipment dealer cannot supply you, order direct.

PAYNE PRODUCTS COMPANY

Cron-O-Matic Division

2454 W. Stadium Blvd., Ann Arbor, Mich.

- () Please send free literature on Cron-O-Matic Carbon Saver.
- () Please ship Cron-O-Matic Carbon Saver, () C.O.D., including postage. () Remittance herewith.

NAME

THEATRE

STREET

CITY & STATE

Dealer Inquiries Invited

Export: Frazer & Hansen, Ltd.
San Francisco, New York, Los Angeles

NATIONAL THEATRE SUPPLY

Celebrates Its

25th

1951

1926

Anniversary

**A QUARTER CENTURY
OF SERVICE TO THE
THEATRE OWNER**

*We Are Proud to
Distribute the Products
of the World's Leading
Manufacturers of
Motion Picture Equipment*

**NATIONAL
THEATRE SUPPLY**

Division of National • Simplex • Bludworth, Inc.

a graded surround illumination. Newhall pointed out that the "surround effect" depends very much upon the visual angle subtended by the screen, and also upon the portion of the total visible angle that is covered by the "surround" under consideration.

3. CONDITIONING LIGHT LEVEL

Newhall pointed out several times during the discussion that the results obtained in a study of vision such as is anticipated in this discussion, depend greatly upon the conditioning level of illumination. He stressed the importance of conducting the test with the observers conditioned in the manner of a practical theatre audience.

4. VIEWING ANGLE

O'Brien in summarizing his previous experiments felt the outstanding defect was too restricted a viewing angle and pointed out that this defect was common to most of the early work on theater viewing. Spragg and Newhall, in discussing the interrelationship between surround brightness and viewing angle, pointed out the possibility that the optimum brightness may be a function of the viewing angle and that it should be so specified. Such a relationship might provide a basis for correlating indoor and outdoor theater recommendations.

Evans pointed out that committees of the Tv industry have been formulating questions similar to those proposed by the Committee, and that the scientific information desired by each group has much in common. For example, Tv viewing is very similar to motion picture screen viewing excepting that motion picture screen viewing angles are from 1½ to perhaps 6 screen widths, while Tv viewing begins at 6 screen diameters and continues to smaller angles.

O'Brien suggested a cooperative research effort to determine the functions of Tv and motion picture viewing, spanning this angular range.

5. VIEWING DISTANCE

Evans suggested that the influence of viewing distance cannot be neglected even when viewing angles are duplicated, and he recommended that at least some of the experimental work be done under the actual viewing distances—in addition to small screen studies that duplicate viewing angles only. One effect of viewing distance, for example, may be to influence the comfort of the visual task.

6. SUBJECT MATTER OF PICTURES

Evans pointed out that it may be much more important to have a large number of test scenes rather than to have a large number of viewers. He pointed out, for example, that the British choice of 7 ft-L for Technicolor and 12 ft-L for black-and-white viewing can easily result from a difference in the subject mat-

ter of the two film sections, rather than any fundamental difference in viewing. Evans and O'Brien proposed that by all means both color and black-and-white films be used.

There was at first a proposal that the

viewing should duplicate actual conditions, employing a sound track along with the picture since that is the normal projection procedure. Evans and Weaver objected, however, pointing out that if sound affects vision, it will not be nearly so easy to judge how pleasing the picture is if there is a simultaneous, possibly distracting, sound track.

Judging Image Quality

If other than the viewing task itself is examined, O'Brien pointed out there will be no way of judging picture quality except by apparent fatigue, headache,

BUY U. S. SAVINGS BONDS

Your Very Best Buy

BUY U. S. SAVINGS BONDS

HANOVER *Continuous* CARBON BURNER

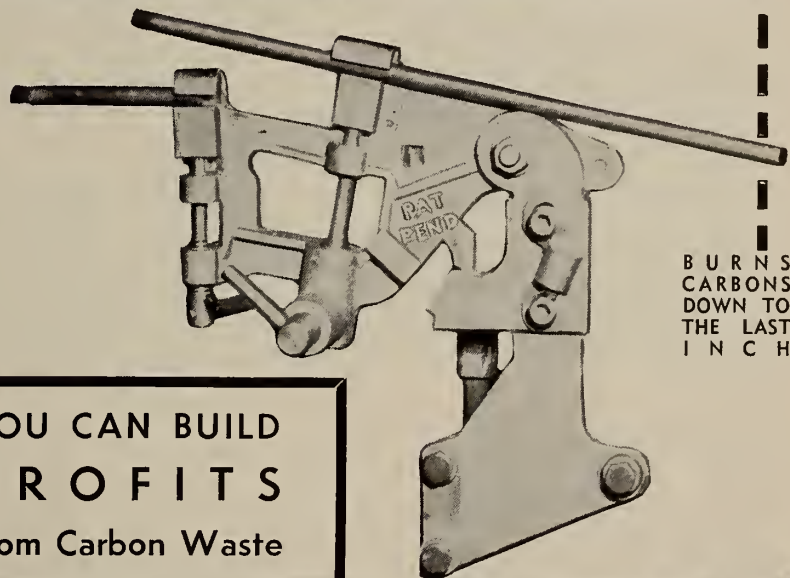

BURNS
CARBONS
DOWN TO
THE LAST
INCH

YOU CAN BUILD
PROFITS
From Carbon Waste

5 YEAR PRODUCT GUARANTEE . . . MONEY BACK GUARANTEE

UNBEATABLE FEATURES: Any operator can install it . . . quickly, easily in a Suprex type lamp. Parts don't wear out—no maintenance cost. Precision built, completely automatic. Pre-heats incoming carbon. No disruption or loss of light in changeover. Eliminates uncertainty of burning period of any size carbon stub. Pays for itself immediately by using accumulated waste.

TELL THE MANAGER TO ORDER TODAY

NORPAT SALES, INC.
45 W. 45th St., New York 19, N. Y.

Dear "Doc":
Please send C.O.D. a Hanover Continuous Carbon Burner at \$77.50. I will install it immediately. If not satisfied after 5 days from date unit is received I may return it for full refund.

Lamp mfr. and Type
Pos. Carbon Sizemm.
Name
Address
City Zone State

CLAYTON BALL-BEARING EVEN TENSION TAKE-UPS

For all projectors and sound equipments

All take-ups wind film on 2, 4 and 5 inch hub reels.

Silent Chain Drives

THE CLAYTON REWINDER

For perfect rewinding on 2000-foot reels.

CLAYTON PRODUCTS CO.

31-45 Tibbett Avenue

New York 63, N. Y.

etc. (Actually there seems to be no such thing as strictly visual fatigue. O'Brien pointed out, since the factors formerly attributed to "visual fatigue" are being explained by other factors entirely.)

O'Brien reported that the pictures for his experiment were chosen purposely to have neither interest nor boredom, because it was necessary to project them a number of times in testing a single observer. The results in such a test, he pointed out, may be different from those that would be secured with an interesting picture viewed for the first time only. Newhall emphasized that pertinent research must be based upon typical films.

In the discussion of color versus black-

and-white, Spragg asked whether the permissible brightness range might be more easily limited for color pictures. Evans pointed out that color prints cannot be projected with as high screen brightnesses as black-and-white prints without a shift in color balance. Most color processes tend to depart from balance in the deep shadows, and the brightnesses must be kept low enough so that this departure is not obvious. The lower screen-brightness limits for acceptable image quality of both black-and-white and color appear to be equal.

Print Density Factor

The print density should correlate with release prints: Chambers pointed out that Tuttle's early work on print density is no longer applicable because of the general change to fine-grain emulsions for black-and-white, and that therefore the measurements of current print densities should be repeated. The question was raised and left unanswered—whether the ultimate result of increased available screen brightness might not be a mere increase in print density.

Chambers pointed out the commercial necessity for screen brightness uniformity such that the review-room brightnesses match the theater brightnesses, in order for the exhibitors to realize the kind of picture that is created by the directors and producers. Failure to keep this balance is responsible for the poor reception of some otherwise good pictures.

Nature of the Observer's Report

Spragg suggested that since the purpose of these experiments is to provide better theater viewing, the most import-

ant criterion is to meet the observer's preference. This type of judging was the basis of O'Brien's early experiments. Spragg suggested getting data from large scale experiments such as a whole auditorium full of observers.

It is desirable, the group agreed, to get observers who are not self-conscious of their task. This is difficult to realize, however, and the use of repeated matter with fewer observers is an experimental risk that sometimes cannot be avoided.

Spragg suggested that in his experience it has been preferable to have untrained observers judge which of several conditions they prefer rather than to have them manipulate conditions to reach an optimum. Typical of this procedure, Spragg pointed out, is the CBS practice of equipping its studio audiences with "yes" or "no" pushbuttons which are summed electrically. The audience is asked to indicate its reaction to the show as it progresses, and the electrical summation gives a continuous record of show interest.

Sampling Audience Reaction

Weaver suggested audience sampling, giving cards to the patrons of actual theaters, on which they might indicate they liked the performance and whether they would prefer to have had a brighter



• The NEW, improved, positive method of permanently patching all types and makes of film—8mm., 16mm., 35mm., Trucolor, Technicolor, Kodachrome, Nitrate and Safety Film.



Used and endorsed by Projectionists in countless theaters.

specifically for lasting Patches.

ESSANNAY ELECTRIC MANUFACTURING CO.
Chicago 10, Illinois 1438 North Clark Street

ONLY Century PROJECTORS HAVE EVERYTHING

CENTURY'S high-efficiency projector with the NEW 4-inch diam. lens provides pictures of increased brightness and appeal—for even the largest drive-in screens.

CENTURY'S water-cooled aperture gives as much light with a 90 ampere arc as other projectors using a 180 ampere arc and heat filters!—Reduce power cost—Get sharper pictures—Save film.

CENTURY'S sealed, oil-less bearings and glass-hard gears reduce maintenance costs. No oil sprays or baths to mess up film or projection room.

You can SEE and HEAR the difference!

CENTURY PROJECTION AND SOUND SYSTEMS
See your dealer or write for information

CENTURY PROJECTOR CORPORATION
New York, N. Y.

4-inch diam. lens mount
Water-cooled apertures
Oil-less Bearings

You Can't Buy A GOOD Rectifier for Less!

Strong Rectifiers are the only rectifiers on the market which are especially designed, manufactured and tested in one plant together with and for use with motion picture projection arc lamps. This is highly important, as efficient operation of each type and rating of arc necessitates a rectifier specifically engineered to its particular requirements.

There is a dependable Strong Rectifier for every type projection lamp: 2-Tube • 4-Tube • 6-Tube • Single and Three Phase Models for

- Rotating Feed Angular Trim High Intensity
- Copper Coated Coaxial High Intensity
- 1 K.W. High Intensity
- Low Intensity

All assure smooth output current, long life, low operating temperature, and flexibility in control.

WRITE FOR LITERATURE OR FREE DEMONSTRATION

THE STRONG ELECTRIC CORP.
CITY PARK AVE. TOLEDO 2, OHIO
PROJECTION LAMPS
SPOTLIGHTS • RECTIFIERS • REFLECTORS

or dimmer picture. Such sampling can be done at successive shows at varying screen brightnesses.

Chambers suggested that audience background-noise level might be lower and applause- and laughter-level higher at the best projection brightness levels, therefore, a better method of audience sampling might be to record the audience-noise level—"applause meter reading"—in a theater where the screen brightness can be varied from one day to another. This recording meter program, he pointed out, is extensively used in Hollywood to judge previews, and there has been found a presumable relationship between audience enjoyment and audience-noise level.

Spragg observed that the audience reaction to the pictures as judged by such meters is consistent, and if an audience laughs for a given time at a particular part of the picture each audience will repeat with amazing reproducibility.

Audience-Preference Meters

Chambers pointed out that 20th Century-Fox has used such meters in their West Coast preview theaters and that equipment-wise they are prepared to provide a range of screen brightnesses up to and beyond the usual levels. He suggested that 20th Century-Fox be invited to run such tests in theaters now fitted with these applause meters, where on successive days of projecting the same program, the screen brightness would be varied and the day-to-day audience reaction compared.

Such a comparison, he said, might give some very real and important data for answering the question of whether screen brightness is really important in judging the quality of a projected picture.

Proposed Accomplishments

In the discussion it was pointed out that the present standard, while intended to be temporary, has functioned as a permanent standard for 15 years. During this time changes in equipment, films, theaters, etc., have been directed by the existence of this standard toward the maintenance of a constant screen brightness with variations in picture size, etc. It would be desirable, therefore, for fundamental research to indicate more clearly what optimum screen brightnesses should be, so that future technical improvements could be directed toward this optimum.

Even though present limitations might make it impossible for the optimum brightness to be realized, and even though a working standard might have to compromise with this optimum, the existence of suitable basic data should make possible the best possible compromise. Accordingly, the best attainable projection conditions would become the work-

ing standard, with future technical advances directed closer and closer to the optimum.

Conference Consensus on Topic

Consensus of opinion of this discussion was that a great deal of basic data on the factors influencing the viewing of projected pictures still remains to be determined. The conference agreed that it should be entirely practical for the Screen Brightness Committee to outline desirable research goals in such a man-

ner that intelligent work directed toward their end would provide a real contribution to the science of viewing.

The conference felt that if the problems could be stated properly and succinctly, and if suitable guidance could be available, there might be a number of groups willing to undertake the work as: (1) university research by students and staff members interested in the general field; or (2) industrial research sponsored by the companies interested in motion picture projection.

Concert Hall
Quality Sound

ROYAL
SOUND MASTER

A New Concept
of Performance
Plus

ALL
NEW

MODEL 9 SOUNDHEAD

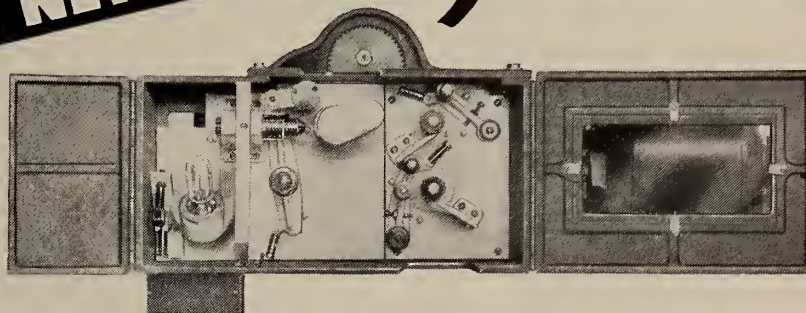

SIMPLER OPERATION

Ballantyne engineering skill has simplified soundhead operation to a foolproof, almost mechanical procedure. The guesswork is gone.

GREATER ACCESSIBILITY

Sensational new innovations in design and construction provide greater accessibility to the interior of the soundhead for threading, adjustments, and parts replacements. Operators will welcome

these startling improvements . . . found only in the Royal Soundmaster Model 9.

FLAWLESS FIDELITY

Skillful engineering now gives you ALL of the sound on the sound track . . . the high tones and the low tones . . . the shouts and the whispers . . . in perfect clarity and fidelity. Operators and theatre owners alike will appreciate the many new and revolutionary features found in the Royal Soundmaster Model 9.

See it at the T.O.A. Show, September 23 to 27
Hotel Astor, N. Y. • Booths 112, 113

THE BALLANTYNE COMPANY

1707-17 Davenport Street

Omaha, Nebraska, U.S.A.

NEVER HAS

Economy

BEEN SO

ESSENTIAL AS NOW!

THERE IS A LORRAINE CARBON TAILORED FOR
YOUR SPECIFIC PROJECTION REQUIREMENT

Send necessary projection equipment data to guide us in recommending the Lorraine Carbons that will do your theatre or drive-in projection job better and More Economically.

SLOW BURNING

SAVINGS IN POWER CONSUMPTION

SAVINGS IN MAINTENANCE

ECONOMIZE

WITH *Lorraine Carbons*

Lorraine CARBONS, INC., BOONTON, N. J.

THE MAGIC OF COLOR

(Continued from page 6)

genta light; tragedies and genre films with blue; slapstick comedies with yellow; mysteries and "horror" pictures with green or purple; adventures with red; westerns with amber, etc. But the titles of natural-color films should not be color-flooded because the titles are already colored.

When colored light is thrown upon a colored picture, the color-changes produced obey the *additive* laws of color formation discussed in the first part of this series. If the dominant hue of a Technicolor title background is red, blue light will change it to purple, and green to yellow. The lettering, if it be of another color, will undergo changes of hue which may cause it to "clash" in an unpleasing way with the background.

Auditorium lighting — especially illuminated clocks, exit signs, and sidelights in the vicinity of the stage—merits careful consideration. Of all colors, red is the most distracting; green the least. Sidelights near the front of the auditorium should be dispensed with entirely, if possible. Clocks and exit signs should be lighted with green, not red, bulbs. Aisle lights should be left white, the recommended blue not having sufficient visibility to assist patrons in locating their seats.

Technicolor Changeover Cues

It will be noticed that the changeover cue used on Technicolor prints is a serrated black disk outlined in green. The green circle is readily visible to the projectionist, who, of course, is watching for its appearance; but it is less noticeable to the audience than a white or red circle would be. This is another practical application of the fact that green is the least obtrusive of the colors.

The green outline is produced by inking the edges of the holes punched in the emeraude-exposed negative. This leaves a *white* ring surrounding the cue mark in the magenta-inked matrix. Through this white circle appear the yellow and cyan overprints in the positive. The yellow and cyan superimposed give emeraude, a slightly yellowish green.

Constant Focus Check

And this brings up the matter of changeovers when color films are being shown. The arc of the incoming projector should be struck at least 3 minutes in advance of the changeover in order that the discolorations inevitably produced by a "cold" carbon trim be avoided. The arc should be given a chance to "settle down" to normal burning before the changeover is made.

Focus must be checked at the start

of each new reel of color film, and once again when the reel is about halfway through. "Film curl" causes focus drift; and nearly every roll of film has enough curl to throw the focus out slightly as projection progresses. Focus drift is likely to be really troublesome at times when lenses of short focal length (4½ inches E.F. or less) are employed.

A change from black-and-white to color *in the same reel* requires *immediate* refocusing of the picture.

The painstaking projectionist and the astute exhibitor are correct when they adopt a very critical attitude toward projection quality. Both know well that their livelihood depends upon patron satisfaction.

When projection faults are discovered, they should be diagnosed and corrected without delay. Projector parts, new lamps, and new lenses are much less expensive than loss of patronage. Many a theater business has been saved by replacing obsolete and cheaply built equipment which does not meet minimum standards of performance.

Old-Style Equipment Tabu

Bad projection is on a par with poor pictures, uncomfortable seats, and an uncongenial atmosphere in the theater. One or more of these factors, if present, can ruin any theater. There is no projector mechanism, lamp, or sound-system in existence which cannot be improved by the application of advanced concepts of equipment design; but the

equipment now being offered is so far ahead of the archaic and worn-out "junk" with which thousands of projection rooms are cluttered that comparison is superfluous.

Color photography and sound recording have both forged ahead with giant strides in recent years. Old-time projectors and sound systems simply cannot do justice to modern films. *Now* is the time for the wise exhibitor to catch up with patrons' demands for high-grade screen entertainment. *Now* is the time for every theater-owner to make secure his investment against competing forms of entertainment. *Now* is the time because nobody—but *nobody*—can predict with assurance what may happen in these parlous times.

(The End)

SMPTE Hollywood Convention

Plans have been completed for the forthcoming 70th Semiannual Convention of the Society of Motion Picture and Television Engineers, to be held at the Hollywood-Roosevelt Hotel, Hollywood, California, October 15-19. Highlights of the Convention will be sessions on High-Speed Photography, Television, Magnetic Recording and Color Television. Taking time out from the week-long technical sessions and committee meetings, the Society, at its Semiannual Banquet on Wednesday, October 17, will present special awards for the most recent outstanding technical contributions to both motion pictures and television, including the newly established David Sarnoff Gold Medal Award.

How Many?

Was this copy dog-eared when it came to you? How many men read it ahead of you?

You would receive a clean, fresh copy if you had a personal subscription—and you wouldn't have to wait—you would be first to read it.

Use coupon below.

INTERNATIONAL PROJECTIONIST.

19 West 44 St., New York 18, N. Y.

Enter my subscription for 1 year—12 issues—\$2.50
 2 years—24 issues—\$4.00

Foreign and Canada: Add 50c per year.

Name

Address

City State

★

★

Medal of Honor



Sergeant Charles Turner, of Boston, Massachusetts—Medal of Honor, Korea. On September 1, 1950, near Yongsan, Korea, Sergeant Turner took over an exposed turret machine gun on a tank. Despite fifty direct hits on the tank, he stayed by his gun and destroyed seven enemy machine gun nests before he was killed.

You and your family are more secure today because of what Charles Turner did for you.

Sergeant Turner died to keep America free. Won't you see that America *stays* the land of peace and promise for which he gave his life? Defending the things he fought for is *your* job, too.

One important defense job you can do *right now* is to buy United States Defense* Bonds and buy them regularly. For it's your Defense Bonds that help keep America strong *within*. And out of America's inner strength can come power that guarantees security—for your country, for your family, for *you*.

Remember that when you're buying bonds for national defense, you're also building a personal reserve of cash savings. Remember, too, that if you don't save *regularly*, you generally don't save at all. Money you take

home usually is money spent. So sign up today in the Payroll Savings Plan where you work, or the Bond-A-Month Plan where you bank. For your country's security, and your own, buy U. S. Defense Bonds now!

***U.S. Savings Bonds are Defense Bonds - Buy them regularly!**



The U. S. Government does not pay for this advertisement. It is donated by this publication in cooperation with the Advertising Council and the Magazine Publishers of America as a public service.

1926

1947

1927

1948

1928

1949

1929

1950

1930

1951

Congratulations

**NATIONAL
THEATRE
SUPPLY**

ON COMPLETION OF

25 Years

OF SERVICE

TO THE MOTION PICTURE INDUSTRY

Simplex X•L
T.M. REG. U. S. PAT. OFF.

PROJECTION AND SOUND SYSTEMS

MANUFACTURED BY INTERNATIONAL PROJECTOR CORPORATION • DISTRIBUTED BY NATIONAL THEATRE SUPPLY

PROJECTIONIST

INTERNATIONAL



THE LIBRARY OF
CONGRESS
SERIAL RECORD
NOV 2 - 1951
COPY

OCTOBER

1951

VOLUME 26

• NUMBER 10

30c A COPY • \$2.50 A YEAR

ALONGSIDE THESE LAMPS STAND THE WORLD'S FINEST PROJECTIONISTS

Peerless

1-KW TO 70 AMPS

MAGNARC
TRADE MARK REG

"HY-AX" ARC MAGNET

"HY-LUMEN" REFLECTOR

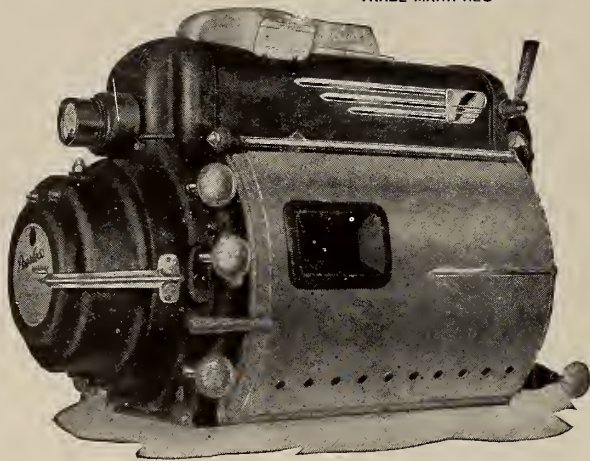

More light at 40 to 70 amperes than ever thought possible. . . Equals and excels any reflector lamp to 85 amperes, whether they be unapproved water-cooled or resurrected "Hi-Lows". . . Highest ratio of honest screen lumens per arc watt. . . At 70 amperes, using an accurated Glass Hy-Lumen Reflector*, with a projector having an efficient revolving shutter, it develops the maximum screen brilliance that can be used without a heat filter at no risk of film damage. . . Operating costs under these conditions are far below that of 85-ampere lamps.

Magnarc Lamps assure 80% side-to-center (SMPE Standard) screen light distribution, not a deceptive 60% or "Hot Center". . . They are all Und. Lab., Inc. listed. . . They are not insurance hazards. . . They are and have been for years "The First Choice" of large and small theatres, drive-ins, and the motion picture industry.

* Similar results are not guaranteed if all-metal reflectors are used.

"FIRST WITH THE FINEST"

130-180 AMPERES

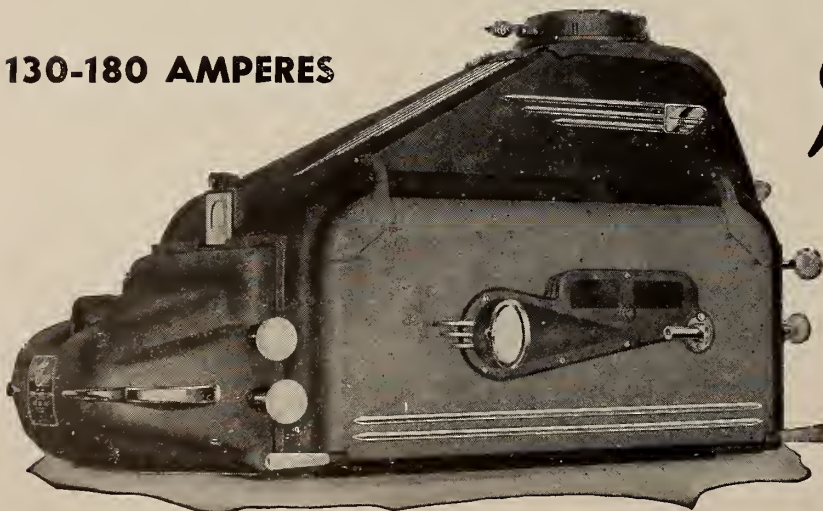

Peerless
HY-CADESCENT
TRADE MARK REG

NEW MAGNETIC STABILIZER

This modern lamp produces all the light there is . . . It is the standard equipment of the nation's largest and finest theatres. . . Used by 90% of the largest Drive-In Theatres.

It is the "Omega" for maximum screen brilliance. . . Nothing can even approach it in white light volume when used with projectors that have efficient revolving shutters.

Assures satisfying projection for Drive-Ins regardless of the size of the picture, length of throw, and under all weather conditions. . . They are Und. Lab., Inc. listed and, therefore, not insurance hazards. . . Heat filter assures no risk of film-heat damage at maximum arc amperage and maximum screen lumens.

"WHY EXPERIMENT?"



J.E. McAULEY MFG. CO.

552-554 WEST ADAMS STREET
CHICAGO 6, ILLINOIS

PROJECTIONIST

With Which Is Combined PROJECTION ENGINEERING



HENRY B. SELLWOOD, Editor

Volume 26

OCTOBER 1951

Number 10

<p>Index and Monthly Chat 3</p> <p>Is Lenticulated Color-Film Practical? 5</p> <p style="padding-left: 20px;">ROBERT A. MITCHELL</p> <p>Projection in Britain's Telekinema 11</p> <p style="padding-left: 20px;">A. BOWEN, J. MOIR, AND H. TURNER</p> <p>For the Record 13</p> <p>Latest Maskless Screen Wins Audience, Technician Favor . . 14</p> <p>'Showboat': Cameraman's Dream 14</p> <p style="padding-left: 20px;">GEORGE SIDNEY</p>	<p>In the Spotlight 16</p> <p style="padding-left: 20px;">HARRY SHERMAN</p> <p>The Allied Arts & Sciences . . . 18</p> <p style="padding-left: 20px;">II. Photographic Optics BAUSCH & LOMB OPTICAL CO.</p> <p>Telecasts 20</p> <p>Tv: Time for Reappraisal 21</p> <p style="padding-left: 20px;">ABEL GREEN</p> <p>News Notes</p> <p>Technical Hints</p> <p>Miscellaneous Items</p>	
--	--	--

Published Monthly by

INTERNATIONAL PROJECTIONIST PUBLISHING CO., INC.

19 West 44 Street, New York 18, N. Y.

Telephone: MUrray Hill 2-2948

R. A. ENTRACHT, Publisher

SUBSCRIPTION REPRESENTATIVES

AUSTRALIA: McGills, 183 Elizabeth St., Melbourne

NEW ZEALAND: Te Aro Book Depot, Ltd., 64 Courtenay Place, Wellington

ENGLAND and DOMINIONS: Wm. Dawson & Sons, Ltd., Macklin St., London, W. C. 2

YEARLY SUBSCRIPTION: United States and possessions, \$2.50 (two years, \$4); Canada and foreign countries, \$3; single copies, 30 cents. Changes of address should be submitted two weeks in advance of publication date to insure receipt of current issue. Entered as second class matter February 8, 1932, at the Post Office at New York, N. Y., under the act of March 3, 1879. Entire contents copyrighted 1951 by International Projectionist Publishing Co., Inc. INTERNATIONAL PROJECTIONIST is not responsible for personal opinions appearing in signed articles in its columns.



420

MONTHLY CHAT

THE most important development at the recent convention of the Theater Owners of America, to our mind, was not the gaudy equipment show nor the protracted discussions anent theater Tv but rather the report of a special TOA committee to the effect that careful investigation showed that equipment standards in more than 40% of motion picture theaters were definitely below par. And we take the word "par" to mean something less than acceptable.

This is a serious indictment of a group of showfolk who talk blithely of spending \$15,000 and more for theater Tv equipment but will not invest a fraction of this sum for those units which will serve up a decent screen image. Incredible though it may seem to the majority of urban projectionists, the fact is that there still are hundreds—maybe 1500—theaters which utilize low-intensity projection.

We're all for the lush carpeting and swellegant decor in a movie theater, but none of these factors contributes to the image on the screen. We're all for, too, the untiring efforts of lamp manufacturers to provide ever more and better light; but it seems a little silly to us to sound off about 15,000 lumens when there remain so many theaters with outmoded projection plants.

It's natural that the small exhibitor should seek to get by on an "as is" basis, particularly in view of a sagging box-office which only recently has begun to perk up. However, the extinction of hundreds of these small theaters will become a fact even sooner than is prophesied if an effort is not made to replace and repair that junk which today passes for projection equipment.

Some enterprising manufacturer might do himself a lot of good by directing a special campaign to these smaller theaters, not as a one-shot gesture but on a steady, methodical basis. And the first port of call should be the projectionist so that he and the supply man could put up a common front to Mr. Exhibitor. We have an idea that such a move would pay off.

* * *

It now appears certain that within six months there will be some 200 theaters equipped for Tv showings *via* either the direct-projection or intermediate-film systems. Looming large among the many problems posed by this development is that of projectionist competency. No amount of instruction by a field engineer will serve to give the projectionist the "feel" of an equipment: this can be had only by actual operating experience. If there is a theater Tv equipment in your area, drop around and spend as much time with it as you can. No instruction book can match such experience.

It would be a nice gesture if Tv manufacturers were to sponsor a series of Tv instruction clinics similar to those given by RCA.

**There's
NO
SHORTAGE
of Light**

ON THE SCREENS WHERE THEY USE . . .

NATIONAL EXCELITE

75 to 130 ampere high intensity reflector type

PROJECTION ARC LAMPS

and that goes for the biggest screens!
Why not have the brightest pictures in town, with
lower operating costs?

Distributed by
**NATIONAL
THEATRE SUPPLY**
Division of National • Simplex • Blodworth, Inc.

"THERE'S A BRANCH NEAR YOU!"

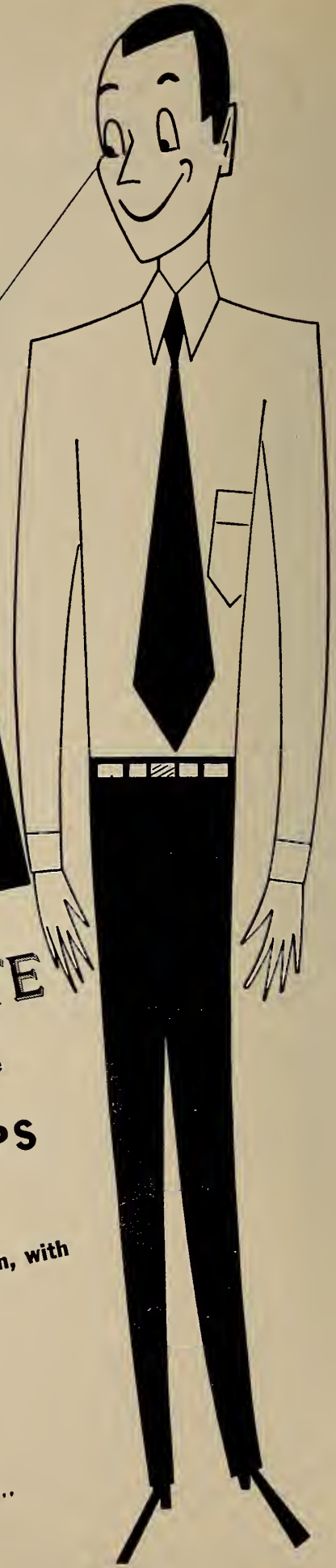



Is Lenticulated Color-Film Practical?

THE proclivity of Hollywood brass to clamp restrictions on all technological progress in the motion picture field is paralleled only by the eagerness with which certain producers pursue any *fata morgana* flaunting the Lorelei promise of by-passing a few pennies of production.

The so-called lenticulated-film process of photographing and projecting movies in natural color is by no means of recent vintage. Eastman Kodak abandoned a variant of the process (known as "Kodacolor") in 1932 in favor of the totally different and immeasurably superior Kodachrome process for 16-mm filming.

Said Thomas E. Hargrave, president of Kodak:

"At least two American motion picture producers and a large European manufacturer have done a great deal of work in this [lenticular film] field over a considerable period of time. So far as we are aware, none of these efforts has yet met with commercial success."*

Industry Interest Revived

Readers of IP will recall that the lenticulated color-film process was described briefly and summarily dismissed on page 34, July 1951 issue of IP. But the recent settlement of the Keller-Dorian patent suit, in which Eastman and Technicolor were co-defendants, has refocused industry attention on the dejected color cadaver which certain production bigwigs are attempting to vivify—in the fond hope that the cost of color footage can be cut by a penny or fractional part thereof.

Should success attend this attempted vivification, however, Mr. Exhibitor

By ROBERT A. MITCHELL

would soon find himself hanging shirtless from a very high limb; while Mr. Producer pockets (he hopes) a trickle of pennies from inexpensive color-film processing. In our humble opinion, the exhibition industry would be best served by *improving* the movies, not by undermining the high degree of quality they already possess.

The theory of the lenticulated-film color process is indeed intriguing (from an academic point of view), and it works just fine and dandy on paper—providing that some mighty important factors are left out of account. So let's go over the whole thing once again with utter frankness, meanwhile offering a fervent prayer that lenticulated film will never be substituted for Technicolor.

Human Color Vision

As far as human color vision is concerned, the entire visible spectrum consists of only three overlapping bands of colors. Three primary colors, no more, no less. These are *Vermilion* (deep orange-red); *Emeraude* (slightly yellowish green); and *Indigo* (deep violet-blue). All other colors are merely combinations, in various proportions, of two or all three of these primaries.

The visual sensation called "white" is nothing more than the result of combining the three primaries in equivalent proportions. This may be demonstrated by a simple experiment.

If we cut strips from vermilion, emeraude, and indigo gelatine (called separation filters by photographers) and place one strip of each color over a

camera lens so that no light can get through the lens without passing through the three filters placed side by side, it will be found that the performance of the lens is not seriously impaired as to image formation or its ability to image colored objects. Only the "speed" of the lens will have been impaired, since comparatively little light is transmitted by the filters.

Color-Filter Action

A distant white building focused upon a white card by the "color-filtered" lens furnishes ample proof that equivalent amounts of V, E, and I light form a white image when they recombine. A red object will give a red image, a yellow object a yellow image, *etc.*

All that happens is that the filters covering the lens split up the light into its V, E, and I components. The image-forming power of the lens recombines these three components into the original colored scene which is focused upon the card.

Another experiment shows what happens when one primary color is missing. Cover up the emeraude filter-strip, and the image of the white building will be colored *magenta*, which is the result of combining equivalent proportions of vermilion and indigo alone. With the vermilion strip covered up, the image will be *cyan*, which is emeraude plus indigo. And with the indigo strip masked off, the image of the white building will be *yellow*—vermilion plus emeraude.

Anatomy of Lenticular Film

Now, an ordinary black-and-white motion picture can be filmed through this "filtered" lens, but the lens diaphragm

* IP for December 1948, p. 35.

will have to be opened wide in order to admit sufficient light.

By using a *lenticulated* black-and-white film in the movie camera, however, a *natural-color* motion picture can be photographed through the lens which has one-third of its area covered by a vermilion filter, another third by an emeraude filter, and the last third by an indigo filter.

Lenticulated film is exactly the same photographically as ordinary black-and-white camera film. The only difference is the presence, on the lenticular film, of innumerable tiny semi-cylindrical ridges side by side. These are impressed in the film base on the side opposite the emulsion by means of embossing rollers. In the old 16-mm Kodacolor process, these corduroy-like lenticulations ran lengthwise on the film; and each had a width of 0.045-mm—about 559 ridges to the inch.

Each "ridge" on the lenticulated film functions as a tiny cylindrical lens.

Light Action Thru Lenticulations

To use the lenticular film, it must be threaded up in the camera with the lenticulated side of the film facing the lens. (In ordinary photography, the emulsion-side of the film faces the lens.) All of the light focused on the emulsion by the lens must accordingly pass through the tiny cylindrical lenses. The second precaution is to have the three colored gelatine strips on the lens parallel to the embossed lenticulations. In the case of Kodacolor, the filter strips were positioned vertically.

Each embossed lenticulation has a focal length of only 0.0045 mm. The lens-action of the tiny ridges causes the image to be split up into three "color bands" in the emulsion of the film, each band corresponding to one, and only one,

of the three filter strips on the camera lens.

One color band contains a vermilion record of a very thin strip of the scene photographed; the second an emeraude record; and the third an indigo record. There is thus a partial image in each of the three primaries under each tiny lenticulation. The sum total of all the partial images on the film is the complete color record of the scene photographed.

The Projection Process

After reversal-development, the lenticular film looks like an ordinary black-and-white positive print. The lenticulations are too small and close together to be visible; and no actual color is present in the film.

To project the film in natural color it is only necessary to place an *exact replica* of the 3-strip camera-lens color filter over the projector lens. As in the camera, the gelatine filter strips must be parallel to the lenticulations of the film.

When the film is projected, light from all the vermilion "color bands" is refracted by the lenticulations to fall upon the vermilion filter-strip on the lens; and light from the emeraude and indigo bands is likewise directed to the corresponding strips of colored gelatine.

By the additive combination of varying intensities of V, E, and I light rays, all the colors originally photographed are reproduced on the screen.

Light Loss Thru Filters

The enormous loss of light occasioned by the filter strips is one of the most serious defects of the Keller-Dorian process, as it is also of *all* additive color-projection processes without a single exception. When Kodacolor 16-mm film

was in use for home service, an aluminum-surfaced screen was necessary in order to obtain sufficient picture brightness. And even with a "specular" screen of this type, a picture no larger than 16½ by 22 inches could be obtained with a projector having a 200- or 300-watt incandescent lamp. Other serious deficiencies of this color process will be examined in detail.

Tests have been conducted quietly with 35-mm film stock embossed with lenticulations 0.03 mm wide—approximately 850 per inch on unshrunk stock. This is about as small as the lenticulations can be without introducing a disastrous loss of color values due to overlapping of two or more "color bands" (each slightly less than 0.01 mm in width) by clumps of reduced silver in the film emulsion.

Emulsion Silver Content

The so-called silver grains in photographic emulsion are really clumps made up of several grains stuck together in a solid mass. When exposed film is developed, an entire clump of silver bromide crystals is either reduced completely to metallic silver or not reduced at all. There is no "half-way" reduction. In the highlights of a photographic image, the clumps of reduced silver are comparatively far apart; in the shadows they are near together, hence much more numerous. The actual size of the individual clumps of reduced silver is influenced by the type of photographic emulsion and the nature of the developing chemicals used.

This overlapping, or "running together," of the color bands can be avoided by altering the form of the lenticulations and the thickness of the film base in order to separate the color bands by extremely thin blank bands. It is estimated that this measure, while improving the purity of the reproduced colors, would result in an additional 25% loss of light.

Screen Image Character

It might be thought that the lenticulations would show up on a large theatre screen as rather wide lines, because of the tremendous magnification of the picture in projection. Such is not the case. When the lenticulations are 0.03 mm in width, they are magnified to a width of 9 mm—almost ¾-inch—on a 15 x 20 ft. screen. The effect is a slight fuzziness of focus, but the individual bands are invisible to the audience.

The inevitable loss of sharp focus is much more serious, however, when lenticulated *prints*, not reversal-processed *negatives*, are projected. Lenticulated prints cannot by any manner or means be made in a standard contact printer. They must be made by optical printing

FIGURE 1. TWO SYSTEMS OF THE LENTICULAR-FILM COLOR PROCESS.

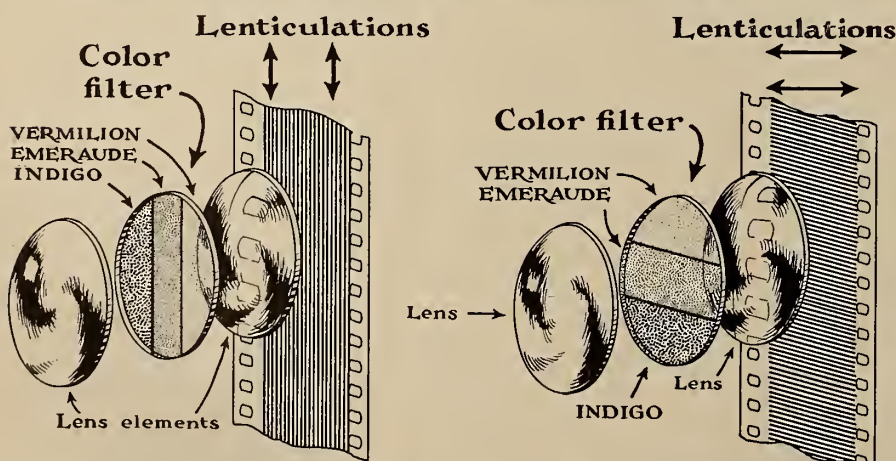

When the embossed lenticulations of the film base run longitudinally, the filter must be positioned so that the three color-strips are vertical. If the lenticulations are lateral, the filter color-strips must likewise be horizontal. Note that the color filter is placed between the lens elements, whether in camera or projector.



*Men, too,
must fly...*

LIKE BIRDS . . . men must fly—soar higher, ever higher—on the wings of their imaginations.

This of itself would be reason enough for motion pictures of increasing insight and originality. But to the constant spur of men's imagination must be added the inspiration of new technics, new equipment and materials.

With this trend toward greater imagination in studio and laboratory has come greater opportunity for the manufacturer to cooperate. The Eastman Kodak Company, for example, as a part of its service to the industry, maintains the Eastman Technical Service for Motion Picture Film. Here, representatives aid the industry in the selection and exposure of film, black-and-white or color . . . help establish higher standards of quality and economy in processing . . . work with exchanges and theatres, helping make sure that each foot of film gets best possible screening.

To maintain this service, the Eastman Kodak Company has branches at strategic centers . . . invites inquiry on all phases of film use from all members of the industry. Address:

Motion Picture Film Department

EASTMAN KODAK COMPANY, ROCHESTER 4, N. Y.

East Coast Division
342 Madison Avenue
New York 17, New York

Midwest Division
137 North Wabash Avenue
Chicago 2, Illinois

West Coast Division
6706 Santa Monica Blvd.
Hollywood 38, California



TO THE STUDIOS...
IT MEANS

**BETTER
MOVIES!**



TO THE THEATRE OWNER...
IT MEANS

**BIGGER
BOX OFFICE!**

It's the **NATIONAL**
TRADE-MARK
CARBON ARC'S **BIG 5**



When you order studio or projector carbons—order "National"!

The "National" carbon arc is an indispensable tool—both to the studios which make movies and to the theatre owner who exhibits them. Why? The "National" carbon arc's BIG FIVE:

- SMALL SOURCE SIZE
- HIGH BRIGHTNESS
- GREAT POWER FROM ONE UNIT
- WHITE LIGHT
- MINIMUM HEAT PER FOOT CANDLE

The term "National" is a registered trade-mark of Union Carbide and Carbon Corporation

NATIONAL CARBON COMPANY

A Division of Union Carbide and Carbon Corporation

30 East 42nd Street, New York 17, N.Y.

District Sales Offices: Atlanta, Chicago, Dallas, Kansas City, New York, Pittsburgh, San Francisco

In Canada: National Carbon Limited, Montreal, Toronto, Winnipeg

For the studio, small source size insures sharp, dramatic shadows, better simulates one-source lighting, creates a perfect "follow-spot". High brightness penetrates deep sets, gives high light levels without excessive heat.

White light matches outdoor shooting conditions, lends itself perfectly to color movies.

For the theatre owner, the carbon arc provides the "brightest spot in the world"—gives him the dazzling power he needs to get diamond-sharp pictures, vivid color and keeps his box office booming. The "National" carbon arc is tops.

**YOU CAN'T SKIMP ON STUDIO LIGHTING
WITHOUT RISKING BOX OFFICE!**

through lenses having the three color strips over them. Loss of definition is doubled in the print, hence the sharpest line possible on a 20-foot screen would be a fuzzy band about $\frac{3}{4}$ -inch wide. This figure assumes the use of a perfect projection lens, "on-the-nose" focusing by the projectionist, and it does not include the ever-present factor of normal emulsion graininess.

In short, lenticulated color is in a fog, as far as focus is concerned.

Filter Quality, Positioning

In order to obtain the best possible color from lenticular film, the color filters in the projection lens must be positioned with great accuracy in regard to azimuth and distance from lens elements. (Of these two factors, a slight error in rotational, or azimuthal, alignment is the less serious, since color-rendition efficiency in this single respect varies directly as the *sine* of the angle subtended by the direction of the film-lenticulations and the direction of the lens filter-strips.)

Moreover, the spectral characteristics of the three filter strips must be well-nigh perfect if any semblance to good color is to be reproduced on the screen. The vermilion filter must transmit only the vermilion region of the spectrum *without a trace of wavelengths lying in the emeraude and indigo regions*. The other two filters must have equally good spectral characteristics.

Filter Dye Factor

But even though such a vermilion (or emeraude or indigo) filter can be prepared, it cannot transmit *all* of the V or E or I light, *but only a fraction of it*. This is because dyes which are perfect from the standpoint of spectral characteristics are far from efficient from the standpoint of light transmission. This unfortunate fact cannot be corrected until chemists discover new and better dyes—absolutely *perfect* dyes, in fact.

The Keller-Dorian process demands perfect filters—but perfect filters have not yet been made.

Summary of Deficiencies

If it be objected that even the (subtractive-process) dyes used for printing Technicolor films are not absolutely perfect, it should be borne in mind that a wide latitude of printing densities is available to Technicolor, making the process 100% efficient as to purity of color, and very nearly 100% efficient in regard to light transmission relative to standards set by black-and-white prints. Technicolor is a remarkably faithful and flexible process. The lenticulated-film process is not.

Why is the lenticulated-film process

inherently inefficient in regard to color rendition? Because of:

1. Unavoidable optical-positioning errors in camera and projector color filters. These arise from differences in the diameters, the focal lengths, and the design of camera and projector lenses.
2. Unavoidable variations in film-base thickness, due to shrinkage and other causes, deforming the lenticulations and resulting in spill-over of light onto the wrong color-filter strips, and even onto the walls of the lens-tube, "washing out" the color and wasting light.
3. Dirt and oil between the embossed ridges, cutting down light and destroying the extremely critical refraction and transmission balance of the lenticulations. Scratches in the film and otherwise worn and damaged lenticulations would cause spurious colors, "fluttery" colors, and low saturation of the reproduced hues.
4. Loss of color intensity in the printing process.
5. The impossibility of using spectrally perfect color filters in the projection lens (to minimize 1, 2, and 4, above) because of the very low transmission efficiency of such filters.
6. The dissimilar shapes of the three filters—two of them being segments of circles, and the middle filter a narrow oblong—and the anaxial optical po-

sitions of the two segment-shaped filters results in (a) objectionable color fringes when the projection lens is but very slightly out of focus and (b) *extreme color distortion*, altering the chromaticity of hues in a very unpleasant manner, whenever "vignetting" is produced either by the lens, the lamp optics, or both—which is usually the case in present-day equipment.

7. The impossibility of avoiding extremely objectionable color fringes on either the horizontal or vertical edges of out-of-focus objects in the picture. This spurious color-fringing is quantitatively much more serious than the chromatic aberration of simple uncorrected lenses, and it restricts lenticular color photography to the use of short-focus camera lenses to avoid out-of-focus backgrounds in closeups and out-of-focus foreground objects in long shots.

Cinematographers have always had available a wide range of lens focal-lengths for both standard black-and-white and color filming. The advantages of such a large assortment are obvious.

For example, the distance of the camera from a scene is sometimes fixed by the physical limitations of the set; yet perfect picture "composition" can be

(Continued on page 29)

FIGURE 2. HOW LENTICULATED COLOR FILMS ARE PHOTOGRAPHED AND PROJECTED.

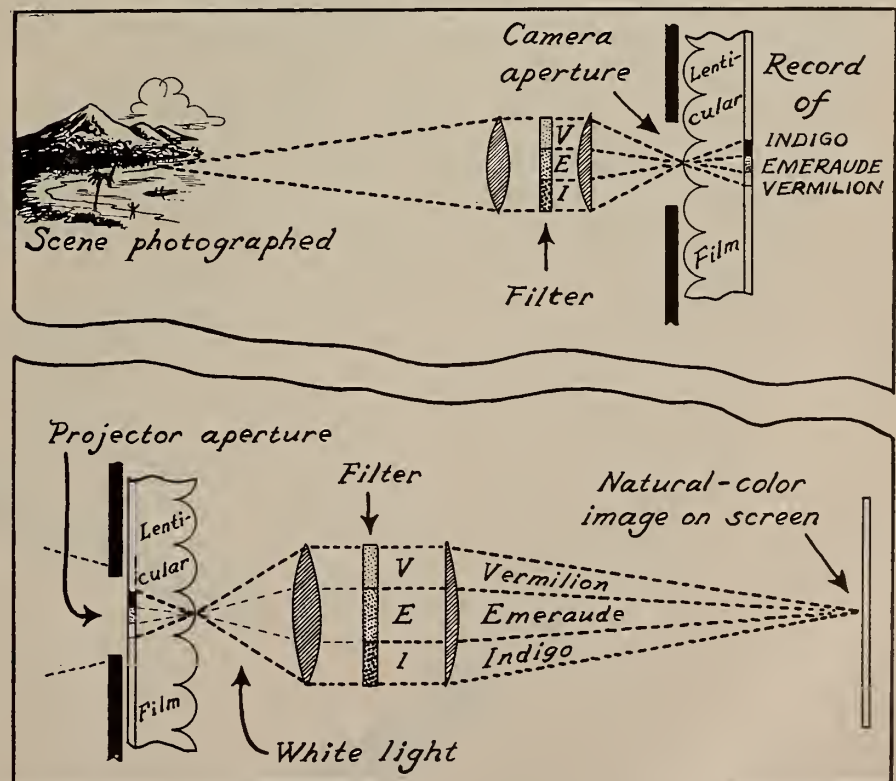

No actual color, but only color values in black and white reside in the film. Color is supplied in projection by a 3-strip filter through which light is directed by the tiny film lenticulations, which act as cylindrical lenses.



RIGHT

for large theatres
for arenas
for ice shows
for auditoriums

**THE STRONG TROUPER
 HIGH INTENSITY
 ARC SPOTLIGHT**

Projects a sharp, snow-white spot without the use of heavy rotating equipment. Quiet... flickerless... portable. Draws only 10 amperes from any 110-volt A.C. convenience outlet. Adjustable, self-regulating transformer in base. Silvered glass reflector. Two-element variable focal length lens system. Automatic arc control. A trim of carbons burns one hour and 20 minutes at 21 volts and 45 amperes. Easily disassembled for shipping.

RIGHT

for small theatres
for hotels
for night clubs
for schools and colleges

**THE STRONG TROUPERETTE
 INCANDESCENT SPOTLIGHT**

Projects 6½ times brighter head spots. Sharp edge from head spot to flood. As contrasted to conventional incandescent spotlights, with which the spot size is varied solely by iris, to result in substantial light loss, the Trouperette utilizes all the light through most of the spot sizes. Variable focal length objective lens system, 5¼" silvered glass reflector, Fresnel lens. Uses standard 115-volt, 1000-watt prefocused projection type bulb. Horizontal masking control can be angled at 45 degrees in each direction. Fast operating color boomerang accommodates six slides. Height adjustable mounting stand. Plugs into any 110-volt convenience outlet.



THE STRONG ELECTRIC CORPORATION
 "The World's Largest Manufacturer of Projection Arc Lamps"
 14 City Park Avenue
 Toledo 2, Ohio

Please send free literature on the Strong Trouperette
 Incandescent Spotlight; Strong Trouper Arc Spotlight.

NAME _____
 COMPANY _____
 STREET _____
 CITY & STATE _____

Projection in Britain's 'Telekinema'

A. BOWEN, J. MOIR, and H. TURNER*

report in "British Kinematography" on the visual and aural projection equipment and technique employed in the model Telekinema theater designed, equipped and operated specifically for the Festival of Britain.

MOTION picture presentations at the recent Festival Of Britain, held in London, were marked by several changes in equipment and technique which should be of interest to projectionists everywhere. As the British expressed it, "the Festival provided an opportunity to obtain public reaction to advanced ideas that have interested the technician for some time without finding adequate public expression."

Early discussion with Festival officials, followed by preliminary demonstrations in the laboratories, resulted in a decision to strive for the following objectives:

1. Projection of ordinary "flat" black-and-white and color sound films.
2. Replacement of the standard black screen border by an illuminated surround projected from the picture mechanism, the intensity and color of the surround being related to the average picture content.
3. A stereoscopic picture using polarized light.
4. A stereophonic sound system with additional "front-of-screen" sound effects.

Two standard 35-mm film projectors (SUPA's) were installed for the projection of normal sound films, the modifications for the projection of the illuminated screen surround, stereo picture film and other special features being added to the basic machine. The only modification required when projecting black-and-white sound film was the addition of a neutral light-absorbing filter in front of the projector to reduce the light intensity on the screen.

A special directional screen of high gain for the benefit of the Tv projector having been installed, it became necessary to reduce the screen luminance to tolerable values when showing film. This filter, and the Polaroid filter required for the stereo picture, were mounted in a disc mounted in a special housing bolted to the front of the projector, selection being made by rotating the disc to the required position.

Halochrome Border

Some pre-war investigations in the B.T.H.* Research Laboratories clearly demonstrated the disadvantage of the black screen masking border, the present

standard practice. The war interfered with the commercial application of the alternative proposals, but the ideas were pursued for the Festival installation.

The black border is a relic of the early days of the industry when screen illumination was low and picture edges rather ragged, but it has become so much a part of a standard motion picture presentation that its presence is hardly questioned. That lusty newcomer, Tv, having a similar problem in masking off the picture tube, tried the film industry's solution, but abandoned it after a few months in favor of a light-colored surround.

Visual acuity is at its maximum when the detail to be appreciated presents the maximum contrast to the background, but the presence of a black border ensures that the maximum contrasts occur at the edges, thus reducing the sensitivity of the eye to the detail in the picture.

In addition to the loss of definition, the darker tones, especially of color films, in the picture are degraded by presenting them in comparison with the real blackness of the masking.

The requirement for optimum presentation of the picture detail and color is clearly that it should be presented against a neutral background such that the highlights are always *brighter* and the dark shadows *blackier* than the surround. These conditions are satisfied by projecting the surround lighting from the film projector in such a manner that the surround intensity and color is the average intensity and color of the picture at all times.

Screen Surround Unit

In the equipment discussed herein this is achieved fairly simply (Fig. 1) by making use of the light normally wasted during the pulldown period when the shutter is closed. The standard shutter is replaced by a special shutter with a reflecting rear surface to direct the light normally wasted upwards to a second mirror which reflects the light forward in a beam approximately parallel to the picture beam and slightly above it.

After passing through a heat filter, the light is directed by a condenser lens onto a full frame-size aperture in a position normally occupied by the framing aperture, and passing through the film is modulated in intensity and assumes

the color of the picture. The color content of the transmitted light is then defocused or diffused to give a uniform color, masked to present the desired shape and projected by a corrected lens system which focuses the mask on the screen.

All the requirements of a perfect background are thus met in a simple manner: the average intensity and color of the surround can be related in any desired ratio to the picture and is automatically maintained without any manual control.

It cannot be emphasized too strongly that the purpose of a projected surround is not to compete with the picture for the patrons' attention, but to present the picture itself in the most attractive light. Considerable experience has convinced us that the advantage of a projected picture surround cannot be secured by any manually-operated device, however flexible in layout and operation.

Stereoscopic Pictures

Present techniques have not reached the stage where it is possible to present a stereoscopic picture to a large audience without making some compromise between what is desirable and what is possible, and in this instance that compromise involved the audience wearing spectacles.

Accepting this limitation as necessary, either two-color spectacles or polarizing spectacles can be chosen, and as the latter enable color films to be presented they have obvious advantages. The right- and left-eye pictures can thus be kept separated right up to the eyes of the audience, and the basic remaining problem is to decide on how the two images should be stored on the film and projected. It was decided to use two separate films, necessitating the synchronous operation of two projectors, the light beams being polarized at right angles by Polaroid filters carried on the projectors.

Requisites for Sterescopy

The requirements for a stereoscopic picture are that the picture should be seen in depth simultaneously by every member of the audience. This effect, either as in Nature or accentuated for dramatic emphasis, must be apparent even in the marginal seats. The brightness of the screen should be adequate from all seats and the whole screen should appear equally bright. This requirement provides conditions which help to produce the stereoscopic effect, which is really due to many factors.

The picture projected to each eye must contain the difference due to its par-

* British-Thomson-Houston Co., Ltd., London, England.

ticular angle of view, and be so presented that the angular position of the eyes of the audience changes with the near and far objects in the scene.

As the picture appears on a single static screen, the eyes of the audience must be focused on it whatever the apparent position of the object. Due to the limited focal depth and power of accommodation of the eye, out-of-focus effects are obtained in ordinary life which aid the stereoscopic view: near objects are out-of-focus when the far ones are seen.

In static stereoscopic pictures the focus is usually sharp all over the picture area, so that time may be spent in looking from one object to another in the picture, the center of interest changing. With a motion picture this is less needed, and the principal object only may be taken in sharp focus to accentuate the stereoscopic effect, while the rest is out of focus.

Stereo Projection System

In the projection system it is necessary therefore to provide an optical system capable of giving definition sharp enough for the principal object to appear at any part of the screen, leaving the out-of-focus effects to the camera. Apparent depth in the picture is also assisted by a large angle of view, so that no real objects outside the picture come into view to spoil the illusion, for although many of the necessary factors are provided by the projection system, it still is the psychological effect in the mind of the observer which fuses the images to produce the three-dimensional picture.

This effect may be achieved by projecting each picture in the usual way, except that the two films must be in register on the screen and must be held in synchronism.

The use of two projectors requires that the lenses of the machines be separated by reason of the size of the machines, and to allow a projectionist to have access to both machines. This produces a parallax different in direction for each machine, and the consequent keystone effects in the horizontal plane are in opposition. The right-hand vertical edge of the left-eye picture is therefore longer than that of the right-eye picture, and *vice versa*. (Fig. 2).

Inter-Lens Separation

This effect also takes place right through the picture, and spatial distortion would be introduced if it were not removed. It is true that this effect is present in the view of a correctly projected picture, but in this case it must be that due only to the inter-lens separation in the camera, which is decided upon by the producer and varies according to the desired dramatic effect.

A rectilinear picture free from key-

stone effects from each machine is secured by offsetting the lens of each machine—the right-hand lens to the left, the left-hand lens to the right.

As mentioned previously, the right-eye picture is kept to the right eye by using a Polaroid filter between the projector and the screen, and by spectacles using Polaroid for each member of the audience. The screen must be capable of reflecting polarized light while retaining the plane of polarization. The planes of polarization are 90 degrees apart, and this gives transmission to one eye and a complete blackout for the other eye.

Each Picture Presented Twice

Each picture is presented twice at 24 frames per second, with a blackout interval between each exposure. We may therefore present the right- and the left-eye pictures alternately, so that the screen is always illuminated and a better continuity of vision is maintained than is the case with flat pictures.

The synchronous running of the two projectors is accomplished by the use of Selsyn motors which provide an electrical interlock between the two machines. The Selsyn motors are mechanically coupled at a one-to-one ratio to the normal driving motors. Using this arrangement, the electrical coupling has to take care only of the differences in speed of the two machines, and the torque transmitted from one machine to the other is very low. A chain and small-diameter bonded fabric sprockets are used to couple the Selsyn and driving motors to keep noise to a minimum.

Framing Adjustments

The framing adjustment normally used when the film is incorrectly threaded is now used to bring the two films

into position to produce a right- and left-eye picture in register vertically on the screen. Horizontal register is achieved by lateral adjustment of the film in either gate, a pellet which steadies the guided edge of the film being provided with screw adjustment to effect this positioning.

In order to produce a rectilinear picture with the brightness curve centrally disposed about the screen center, the projector unit mechanism was set at an angle to the light source, so that the plane of the film in the gate is parallel to the plane of the screen.

The light source gives normal illumination, as its center line passes through the center of the picture aperture to the center of the screen. The projection lenses are mounted in the standard focusing holder with their center lines normal to the plane of the screen.

The screen has a front surface of fine grain particles each of which gives a special reflection and maintains the plane of polarization. The screen is curved in the horizontal plane, and coverage is obtained over the whole of the seating capacity with good uniformity of brightness over the whole screen surface.

Positioning of Projectors

Normally, the projectors stand directly on the floor, but here the projection room was located directly above part of the audience. It was necessary therefore to mount the projectors on anti-vibration mountings. These mountings are designed to give a periodicity of about 16 cycles per second in the vertical plane in order to be effective in reducing noise transmission to the floor.

The machines, being tall in proportion to their width, have a slow torsional period about the fore-and-aft line of the base, and this would have an adverse

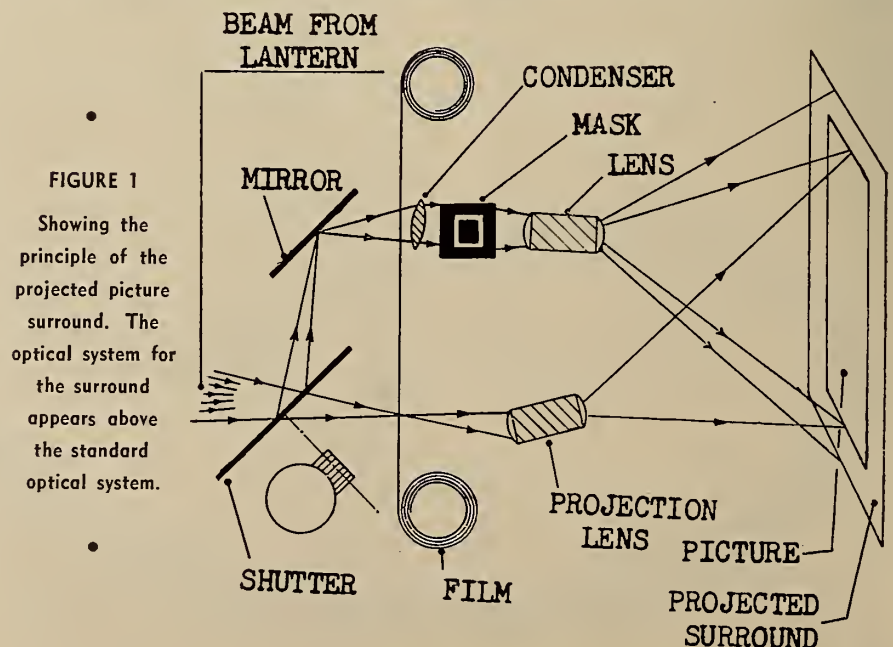

effect on the picture but for a bridge piece which braces the two machines and holds them together.

With the projectors mounted non-rigidly, it would be reasonable to assume that the picture as projected would be less steady than that from a similar projector rigidly mounted. It is found, however, first that the steadiness of each picture is still within normal limits, and secondly that in the stereoscopic picture the remaining movement disappears, giving a remarkably steady picture.

Stereophonic Sound

Present techniques of reproducing sound in the major theaters have reached a high level of performance, and there appears to be little doubt that further refinements of these techniques are unlikely to arouse intense public interest. In spite of this, it must be agreed that no audience could be deceived into thinking that the present electro-mechanical reproduction is the "real" thing.

Of the various possibilities, that of the three-channel stereophonic reproducer, with additional loudspeakers to reproduce special sound effects in the auditorium, seemed to be the most attractive, confirmation of which thought was obtained in an experimental installation. The superiority of three channels rather than two is readily apparent, particularly where dramatic action is to be reproduced.

The majority of acoustic close-ups always occur in center stage and the third (center channel) is invaluable in securing the necessary intimacy. It is noteworthy that Bell Laboratories came to

FIGURE 2
Diagram of a double projector installation using Polaroid filters on the projectors, plus viewing spectacles and projector interlock.

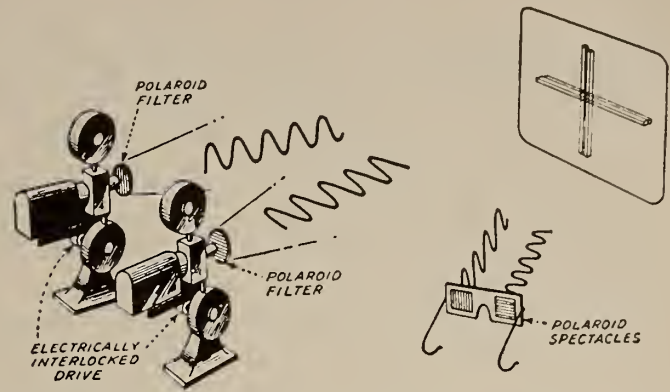

the same conclusion after their tests in America.

The dramatic appeal of sound effects produced in the auditorium, rather than from the loudspeakers behind the screen, was confirmed in first experiments, and at a very early stage in the discussions it was agreed to install additional loudspeakers in the auditorium back walls and in the main and under-balcony ceilings.

Independent Sound Tracks

Four independent sound tracks were therefore required, three for the stereophonic sound effects and one for the auditorium sound effects. Although experiment has confirmed that a wide frequency range is less necessary in a stereophonic system than in a monaural system, it was decided to make the system of wide range. In this and other respects magnetic recording has consid-

erable advantages over present photographic recording techniques.

The provision of four tracks each of adequate volume range necessitated a separate film for sound only; but as this could be met by a relatively simple assembly of standard units, it was of no particular disadvantage in this installation. Synchronous locking of the picture and sound projectors is essential when separate machines are employed, but a locking system was necessary in any case for the projection of stereoscopic pictures.

The standard SUPA projectors required only minor modification in the electrical control system to use them in conjunction with the separate magnetic sound reproducers. Two standard rotary magnetic heads were installed for running magnetic film, each mounted atop
(Continued on page 27)

Putting their best foot forward for the Festival of Britain exhibition, British film technicians designed and equipped a Telekinema Theatre which would acquaint visitors from all over the world with the trend of British thought in terms of things cinematographic.

Visual and aural attractions at the Telekinema included large-screen Tv, three-dimensional motion pictures, stereophonic sound reproduction, multiple film prints which utilized a projector interlock, and a means for eliminating the conventional screen masking by utilizing an accessory optical unit which literally "fed off" the standard projector setup.

One must admire the British "drive" under difficult economic conditions, but it must be said that the Telekinema offered little if anything that has not been done before. To recap:

Recap of Equipment and Processes

Large-screen Tv is old-hat not only in the U. S. but also in Britain. The simultaneous projection of multiple film tracks, with projector interlock, is also of comparatively ancient vintage, the most notable example of which probably was the roadshow presentation of Disney's "Fantasia" (IP for November, 1940,

p. 20). Also in "Fantasia" was the first public demonstration of true stereophonic sound reproduction, using 36 speakers on the stage alone, with 22 small cabinet-type speakers scattered about the auditorium.

The Telekinema utilized two projectors plus analyzers (viewing spectacles) to achieve the three-dimensional motion picture effect. This procedure has been well known on both sides of the Atlantic for many years. IP hopes to be able shortly to describe a system creating the same effect which uses only one projector—plus analyzers, of course.

As for the means employed to eliminate the screen masking—an accessory optical unit—it would seem that our British friends did this job the hard way. Much more simple is the Schlanger method which utilizes no accessory units (described and shown elsewhere in this issue).

The foregoing comments are intended solely for the record and are not intended to detract from the progressivism of British thinking in motion picture technology. Constant hammering away at the tough problems in filmdom on both sides of the Atlantic might well provide the means for extending the life expectancy of the motion picture theatre far beyond the present horizon.

'Showboat': Cameraman's Dream

By GEORGE SIDNEY

President, Screen Directors' Guild of America

This is the story of one phase of technological know-how that is poured into the making of a great motion picture, in this case the Technicolor masterpiece, "Showboat." The original source of the story, the *American Cinematographer* (Aug. 1951). We found it fascinating, an evaluation in which we hope IP readers concur. Ruminating upon the meticulous care lavished upon this production, we wondered on the quality of projection accorded "Showboat" in thousands of theatres.

THE degree to which people become absorbed in a motion picture, and become subjectively involved in a kind of emotional third dimension, is the measure of a picture's success. Because motion pictures are a visual medium, a successful picture often depends on the cameraman's skill in enhancing the action pictorially, leading the audience into this emotional state.

"Showboat" is an example of this cine-

matographic ingenuity. Throughout its entire length, it is replete with deft cinematic touches that point up a player's role or enhance a situation with observable effect on the audience.

Many unusual photographic problems were encountered in filming "Showboat." Most of them were anticipated early and plans consequently made for overcoming them in a series of pre-production huddles that took place before we started

Latest Maskless Screen Wins Audience, Technician Favor

Proponents of the maskless screen are enthusiastic about the recent installation of such a unit in the Plaza Theatre, Scarsdale, N. Y. Designed, fabricated and installed by Ben Schlanger who has waged a long and hard campaign for this unconventional reflecting surface, the Plaza screen represents the fruits of extensive tests under practical operating conditions over the past several years.

Both the screen itself and its immediate surround—sans masking, of course—are woven from the same fabric, thus permitting a vignette effect which permits the projected light to "spill" over on all sides with gradually diminishing intensity of light.

Patron Reaction Excellent

Patron reaction to this modern method of screen presentation was excellent, as indeed was that of the many technicians who witnessed the Plaza showing. This tallies with the reaction of patrons to the screen image in a Connecticut theater which has featured this form of presentation for the past three years.

Maskless screens are not new, of course, but it remained for Schlanger to give the idea its greatest impetus in America. In fact, Schlanger has been waging an arduous lone-wolf battle against the conventional type of masked screen, and it would seem that at last he has won approval for his idea in important technical circles.

An important aspect of the Schlanger

maskless screen is that it can be "packaged"—that is, the individual theater can be equipped without the necessity for an on-the-spot, hand-tailored job. This feature is expected to be an important merchandising factor.

Schlanger holds that the original conception of a non-masked screen wherein consideration was given only to the physical means of seeing has long since been supplanted by the psycho-physical theory which gives precedence to the psychological effect of a vignetted screen image upon the viewer.

Screen Lighting Level Controlling

Only the low screen light level prevailing many years ago justified the use of a black screen masking says

shooting. "Showboat" is the third picture in a row that Charles Rosher and I have made together; so by now we have become pretty much of a team.

Results Were No 'Accident'

Those "old master" touches in many of the colorful scenes of "Showboat" were no accident. They were the end result of countless sessions when together we pored over endless volumes in my library of art and photographic books. Whenever I showed enthusiasm for some particularly colorful or artistic effect in an illustration, Rosher would make a mental note on how to adapt it to some particular scene. I think this is best exemplified in the sequence of shots of William Warfield singing "Ol' Man River," which was actually filmed at dawn, in real fog. The low key result is a masterpiece in color cinematography.

There are a number of scenes in the picture, incidentally, where fog played a dominant part, pictorially. We took advantage of the fact we were producing this picture in December in Culver City, not far from the Pacific ocean, and used

Schlanger. The comparatively high screen light level of today, he avers, has eliminated the need for screen masking, quite apart from any consideration of the greatly heightened dramatic impact upon the viewer which could be realized by the elimination of masking.

The original Schlanger proposal was that the light passing through the edges of an unmasked screen should be so utilized that it would vignette off on all sides of the picture area and illuminate an appropriate surround. This method was held to be applicable with equally good results to both black-and-white and color films.

Additional installations of the Schlanger maskless screen will be made shortly, one in a large Broadway house.

THE SCHLANGER MASKLESS SCREEN SURROUND IN PLAZA THEATRE, SCARSDALE, N. Y.

•
Showing how the screen surround appears in relation to the proscenium and sides, and to the front rows of seats. The surround is made of the same material as the screen, with no accessory optical unit being necessary.
•



the naturally foggy atmosphere for these scenes. Frequently the natural fog in scenes was amplified through skillful use of filters or by addition of artificial fog.

Sometimes, having started to shoot a sequence of scenes under foggy weather conditions, we ran into serious trouble. The fog would lift suddenly and the sun would come out. This called for one of three alternatives: to employ artificial fog and filters, go indoors on the sound stage, or move to another exterior location that called for shooting in full sunlight.

Fog—and Light Balance

Fog, being an elusive thing, became one of our major bugaboos when shooting exteriors on the studio's lot three. It moved in clouds of varying density, creating troublesome exposure problems. We frequently had to depend on constant visual checks of the light, so rapidly did light quality fluctuate. Strict attention to this detail enabled the cameraman to retain remarkable density balance from one shot to the next.

Still another problem was maintaining balance in the lighting when shooting a sequence of fog scenes over a period of days. No two days were alike in light quality. It thus was necessary to keep in mind the light conditions that prevailed each preceding day in order to match it and insure the desired continuity of light quality and direction.

As every cameraman knows, it is relatively simple to shoot in normal sunlight; but battling the elements calls for more than ordinary camera skill. The successful director of photography must be resourceful enough to meet changing light conditions without delay, no matter how severe or how frequently they occur.

A 'Mental Encyclopedia'

Such mid-winter weather conditions demonstrated how important is the cameraman's ability to maintain a sort of mental encyclopedia of detail from scene to scene, where such scenes are not filmed consecutively. He must have an infallible memory for the quality, color temperature and direction of the source of light.

For instance, we were shooting the picture in December; days were short. There were days that dawned foggy or extremely cloudy, forcing us to go indoors and shoot on the sound stage. Then the sun would come out suddenly, and because sunshine was such a precious commodity for the vast number of exteriors we had to shoot, we would halt indoor shooting and move out-of-doors again, shooting until color temperature of the light went below the point where it could be balanced satisfactorily. Then we'd go back indoors, only to find, perhaps, that one of the cast was unavail-

able; so we would then switch to another set. Two weeks later, we would return to the first set and resume shooting there.

It was Rosher's uncanny ability to remember all the camera and lighting details of the original setup that enabled the company to resume shooting as though there had been no interruption. The subsequent takes matched exactly in lighting continuity and quality those made the day shooting first started on the set.

Color Temperature Vital

There are two things in which Rosher excels: his scrupulous attention to continuity of lighting direction from one shot or sequence to another, and his constant vigilance over the color temperature of set illumination.

We both agree that the whole future of color photography is bound up with color temperature, that it is a most important factor in color cinematography, affecting as it does the purity and consistency of color rendition. It is necessary for cameramen to know this when shooting color if skies are to match from scene to scene, and faces and complexions of players are to remain constant from one scene to the next. I think "Showboat" is outstanding for these very consistencies.

Consistency in facial renditions were achieved without resorting to overlighting by reflectors or booster lights. A notable example is the scene, early in the picture, where Howard Keel and Kathryn Grayson, singing together on the upper deck of the showboat, move about—sometimes in partial shadow and then in full sunlight. Also, later in the picture, when Ava Gardner is singing "Can't Help Lovin' That Man" on the afterdeck. She moves from one side of the boat to the other—in and out of sunlight—and there is no appreciable change in her facial rendition, photo-

Red Feather Volunteers

The United Red Feather Campaign in your town needs you as a volunteer solicitor in this fall's big drive for funds.

Your United Red Feather drive is a part of one great national effort to support more than 15,000 local health, recreation and welfare services. New inclusions this year are the reactivated USO and other voluntary health and welfare agencies which are now needed because of the defense effort.

More than a million and a half volunteers are needed to do the job. Volunteer your time now to your UNITED RED FEATHER CAMPAIGN.

graphically, due to skillful maneuvering of the lighting.

These scenes particularly demonstrate what is becoming more and more self-evident: that candid-type photography has at last come into its own in cinematography—candid in that there is more realism in the result, less of the "forced" photographic effect.

Developing Pictorial Emphasis

Many of the memorable camera treatments in the picture were conceived right on the set or location. From a compositional viewpoint, one of the most impressive is the shot of Howard Keel walking along the river's edge. The camera, slightly elevated, looks down on Keel and shows reflections of the gaily decorated showboat in the water behind him—an impressive and colorful backdrop. It was one of those opportunities for pictorial emphasis which was developed to the fullest.

Another example occurs early in the picture. One of the crew, after being severely beaten by Robert Sterling for forcing his attentions on Ava Gardner, leaves the showboat in a rage and goes up the river bank in search of the sheriff. This could have been an ordinary shot made from a simple camera setup on the crest of the river bank, picking up the man as he trudged up the hill. But we saw opportunity to gradually heighten the effect of the man's anger through pictorial emphasis that would make him loom larger as he approached the camera.

Dolly tracks were laid from the crest of the hill, extending out toward the boat on a scaffolding, and paralleling the uphill path. The Technicolor camera, mounted on a movable crane, was set to start the shot from the far end of the track—nearest the boat. As the man left the boat below, the camera was started and the crane pulled back; meanwhile, the boom was gradually lowered until the camera now was below the level of the dolly tracks, almost at ground level. Here it looked up at the raging boatman looming ever larger, and at the same time showed the boat in the distance for a unique compositional effect.

Difficult Location Problems

One of the classic shots in the entire picture is one we filmed on location on the Mississippi river. Prior to starting the picture at the studio, Rosher and I went to Vicksburg, Miss., to shoot scenes of the river packet on which Howard Keel and Ava Gardner meet again, in the latter part of the story. On an earlier location-scouting trip I had located the "Sprague," an ancient river boat tied up at a wharf, where it now served as a

(Continued on page 26)

IN THE SPOTLIGHT



By
**HARRY
SHERMAN**

MOST welcome is the news that RCA has reprinted in compact form under one cover the six articles on the RCA PT-100 Theater Tv system which were written expressly for and ran in serial form exclusively in IP. We say this news is most welcome not to win any "puff" for IP but because for several weeks past now we have been deluged with requests for copies of these articles not only by those who had missed the series but also by those who having read the articles wished to obtain them in compact form.

RCA has reprinted many thousands of these booklets, the content of which was slanted directly at projectionists, and nation-wide distribution is now being effected through the RCA district offices. It is not unlikely that the current supply will soon be exhausted and that a further reprint order will be placed.

IP regrets that it cannot service the many requests for this booklet, since the physical distribution is being handled by RCA. Inquiries concerning the booklet should be addressed to the Theater Equipment Section, Engineering Products Dept., Radio Corp. of America, Camden, N. J.

The aforementioned circumstances demonstrate once more the wisdom of those regular subscribers to IP who don't have to stretch a shoelace to be kept well informed on technical developments each month.

- The greatly expanded activities of the IA have made it necessary to move its general offices to larger quarters. They are now located in the RKO Building, Suite 1900, 1279 Sixth Avenue, New York 20, just one block west of its former headquarters.

- Frank Kinsora, president of Detroit Local 199, was in charge of the Coliseum during the recent Michigan state fair. Roadmen working on the job all spoke very highly of Frank.

- A recent NLRB ruling ordered the immediate reinstatement plus back pay of Kenneth Caraway, who was discharged from his job as projectionist at the Fox

Theater in Coffeyville, Kans. The Board examiner found that "certain interests brought pressure on the Fox Midwest Amusement Corp. to fire Caraway, thereby violating the Taft-Hartley Law."

- Matt Kennedy, former business representative for Local 273, New Haven, Conn., figured in a car smashup that almost cost him his life. Matt and Mrs. Kennedy were driving through the outskirts of Utica, N. Y., en route to Canada where they planned to spend their vacation, when a large truck rammed into the back of their car, completely demolishing the trunk compartment and the rear seats. Miraculously, the Kennedys escaped serious injuries, and outside a few minor bruises and a pretty bad scare they were none the worse for their experience. Their baggage, of course, was destroyed, and the Canadian vacation was indefinitely postponed.

- A banquet at the Bel Sito Restaurant on September 19 marked the 40th anniversary celebration for Local 221, Aurora, Ill. Clinton R. Graeff, president of the Local, presented charter member buttons to Henry H. Anderson, Charles O. Doane, Ralph I. Pulver, Raymond L. Fox (vice-president of the Local), and Walter B. Kline. Serving on the arrangements

committee were Ralph Johnson (secretary-treasurer), Phil Duggan and Raymond Fox.

- Roy M. Brewer, IA Hollywood representative, was appointed as one of the two AF of L members on the Wage Stabilization Board for California, Arizona, and Nevada.

- We are glad to learn that Bill Maxon of Syracuse Local 376 has recovered from his protracted ailment and is once again back on the job. As vice-president of the AF of L Union Label Council, Bill was instrumental in having each theater in Syracuse display a special poster in connection with the recent Union Label week.

- Movietime in Texas was celebrated several weeks ago in conjunction with the nation-wide Movietime USA campaign. Typical of the cooperation of IA Local Unions in this campaign was the advertisement placed in a local newspaper by Local 548, Paris, Texas, a reproduction of which appears herein.

- It has been suggested to this department by a number of our readers, many of whom are IA members of long standing, that it would be a nice gesture on the part of IA Local Unions to present each retiring member with a card upon which appears his union affiliation, date of retirement, and such other data as may be deemed pertinent. The card need not be expensive—just small enough to carry in a regular card case, and will serve as a memento of many years' membership in the union.

- Bert Ryde, popular business representative for Buffalo Local 233, was a recent one-day visitor to New York. He accomplished his mission shortly after his arrival, turned around and headed back for Buffalo the very same day.

- Film Post No. 1292 of the American Legion, formed by members of New York Local 306, held its annual election of officers. The newly elected officers are Al Sprung, commander; Moe Singer, 1st vice-commander; Harold Salkey, 2nd vice-

UNION LABOR BACKS MOVIE TIME USA UNION LABOR endorses



Motion Picture Theatres, indoors as well as outdoor, join the 1,500 other Movie Theatres of Texas in the celebration of MOVIE TIME IN TEXAS. Attend a movie at any theatre. Enjoy yourself in any one of the eight Movie Theatres in the Paris area — always fine entertainment at a modest price.

Moving Picture Machine Operators
Local No. 548 Paris, Texas

Here is an example of the cooperation extended by IA Locals throughout the country to the Movietime USA campaign to spur theatre attendance. In every instance the ad space was paid for by the unions.

commander; Harry Klein, 3rd vice-commander; Archie Hollander, hospitaler; Frank Miller, adjutant; Edgar Heidelberg, financial officer; Francis Costa, sergeant-at-arms, and Harry Waks, chaplain. A. S. (Steve) D'Inzillo and Al Sprung were named to the entertainment committee.

• George Ernst, projectionist at the Grand Theater, Grantsburg, Wis., was severely burned about the face while he was adjusting his projection equipment during an electrical storm. It is believed that a flash of lightning entered a vent pipe running from the projection room to the outside of the building, causing a fire that destroyed the equipment in the projection room and injured Ernst.

• Hugh J. Sedgwick, secretary and business representative for Local 303, Hamilton, Ont., Canada, was the first film man chosen to represent Canada at Britain's recent Trade Union Congress. Sedgwick was the first fraternal delegate of the Canadian Trades and Labor Council. He is active in Canadian Labor circles, and his public service activities include service on the Board of the Hamilton General Hospital and the chairmanship of the Hamilton Planning Board.

• We sympathize deeply with Leo Barber, business representative for Local 245, Lynn, Mass., on the recent death of his wife, Constance. Leo has held office in the Local for many years and is popular in Labor circles.

• Morris J. Rotker, member of New York Local 306 and chairman of the Cerebral Palsy Committee in this city, advised us that he was overwhelmed with the response from IP readers to his recent request for old and discarded greeting cards for the victims of cerebral palsy. He was so deluged with cards from

TWO ARCLIGHT CHAMPS IN HOLLYWOOD



Fred C. Stovenaur, representative for National Carbon Co. in Memphis, pictured with his daughter, movie actress June Haver, who has helped to consume much of her dad's product.

all parts of the country that he has requested us to thank the senders and to ask that no more cards be sent to him. His supply on hand is more than sufficient for his needs.

• We had occasion recently to spend several weeks on the road with a legitimate play utilizing projection. One function, of course, was to run the projection machines. New Haven, Conn., was our first stop, and there we met for the first time Frank Perry, the newly-elected business representative for Local 273. Perry was very gracious and we think the members of the New Haven Local are fortunate in their choice of business representative.

Boston was our second stand, for a three weeks' run, and there we were greeted by Walter Diehl, business representative for Local 182. The Boston boys were most cooperative, particularly Joe Cifre, former president of Local 182 and now head of the supply company bearing his name. We had a little difficulty in setting up our equipment and Joe delegated two of his installation men, Dave Fox and Alfred Otika, to correct the trouble. Fox and Otika, members of Local 182, proved their efficiency by keeping the machines running in tip-top shape during the Boston run of the show.

Our thanks, too, to RCA serviceman Holmquist, who did a swell job on the projectors, and to all those who assisted us in the very successful operation of the equipment.

• For the first time in its 32 years of existence, Local 565, Centralia, Ill., has been forced to resort to picketing in trying to reach an agreement with an exhibitor in its jurisdiction. The owners of the Centralia Drive-In Theater, Homer and Elbert Butler, refused to renew their contract with the Local at the opening of the 1951 season and locked out the union projectionists, running the projection machines themselves. The union officials did not ask for an increase in wages for their members—they were willing to renew the contract on the same terms provided for in the 1950 contract, covering regular and relief projectionists, but the Butlers balked. Organized labor in Centralia rallied to the support of Local 565 and is helping the union both financially and morally.

• The newly formed El Bekal Shrine of Long Beach, Calif., elected two IA men to head its stagecraft unit. Mace Taylor, member of Los Angeles Local 33, was elected president, and Alonzo B. Bennett, secretary of Long Beach Local 521, was named secretary of the unit, in addition to being appointed chairman of the projection and spotlight departments. Max G. Miller, former president of Local 521, was named chairman of the sound department.

HUGH
SEDGWICK

IA man
Canada's
delegate to
British Trade
Union Congress.



The new temple was granted dispensation by the Imperial Shrine Council at the last national convention, and in El Bekal's ranks will be found many "Nobles" carrying union cards.

• Negotiations between Vancouver Local 348 and the Famous Players circuit of Canada have reached an impasse with the Local's refusal to accept a 28c per hour increase recommended by a conciliation board. The Local is asking for an increase of 50c per hour, basing its demand upon the increased cost of living index, which, it is claimed, has reached an all-time high. We understand that the officials of the Local have appealed to the British Columbia labor relations board for a government-supervised strike vote.

25 Years Ago—October 1926

• The new edition of the International By-Laws carried a change in Article 2, Section 21, (page 44), passed at the Cleveland Convention in June of that year, applicable to new members. Heretofore it was necessary that an applicant reside in the jurisdiction of the Local Union to which he made application for membership for a period of only six (6) months. The law now reads that the term of residence be eighteen (18) months, and all Local Unions were instructed to see that this new provision was properly enforced. . . . The General Executive Board met at the Hotel Ft. Wayne in Detroit, Mich., hearing charges and appeals. . . . Producers on the West Coast were notified by the International Alliance, the United Brotherhood of Carpenters and Joiners, International Brotherhood of Electrical Workers, and the United Scenic Artists of America that in the event complete unionization of the West Coast studios was not completed by December 1926, a general strike would be called. . . . Per capita tax to be paid to the General Office was increased to 85c; this included convention transportation and per diem taxes. . . . The General Executive Board approved the action of IA President Canavan in donating \$1000 to Local 545, Miami, Fla., in response to an appeal for assistance after the recent hurricane.

The Allied Arts and Sciences

A vast field of artistic and scientific endeavor is directly contributory to the motion picture process and, therefore, to the practice of projection. The true craftsman should have a well-rounded understanding of these contributory factors, particularly in view of the imminent widespread utilization of television and, possibly, stereoscopic pictures and stereophonic sound. To this end, IP here inaugurates a special department which will provide basic information on the aforementioned arts and sciences.

II. Photographic Optics (Distortion)

Bausch & Lomb Optical Company, Rochester, New York

THIS is the latest of the five monochromatic aberrations, and the one in no way affecting the sharpness of the image. This aberration changes the point-for-point mapping by the lens, so that the sharp image points do not correspond in all respects with the positions occupied by the original object points. The mapping becomes inaccurate in a regular manner, or, expressed more scientifically, the magnification is not uniform over the field of the lens.

This latter is perhaps the best way of visualizing the optical designer's distortion, which should be carefully distinguished from the distortion introduced by a wide-angle lens. The latter is strictly a perspective distortion, while the former can be called a mapping distortion.

If the magnification of a lens is a function of the field angle, one cannot expect to image a square centered about the axis of the lens as a square, but as some queerly-warped figure.

'Pincushion' Distortion

More characteristically, since a straight line near the edge of the field is an object lying at varying angular distances from the axis of the lens, one cannot expect to image that line—be it posted, door lintel, *etc.*—as straight, but must expect to find it curved. In a lens afflicted with distortion, the post will be curved either toward or away

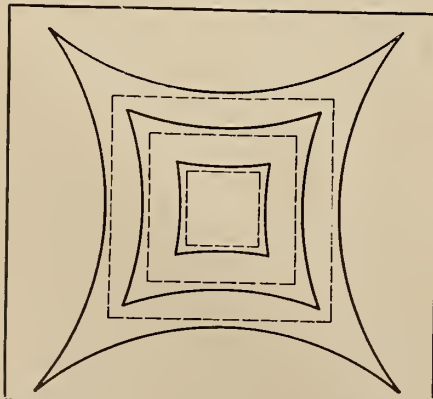

FIG. 14. 'Pin-cushion' distortion.

from the center of the field, depending upon the type of distortion present.

If the magnification in the field is greater than that along the axis, a centered square will present the appearance of a pincushion, with corners sharp and less than 90°, and straight lines will be imaged as portions of curves

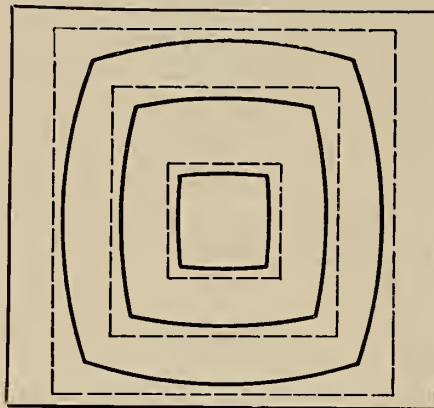

FIG. 15. 'Barrel' distortion.

convex to the center of the field. It is for obvious reasons that this aberration is called *pincushion distortion* (Fig. 14).

'Barrel' Distortion

On the other hand, if the magnification is less in the field, a square will resemble a perspective drawing of a barrel, and lines in the margins will be curved toward the axis. The appellation *barrel* for this type of distortion is readily justified (Fig. 15).

Distortion is controlled by the lens designer through the choice of stop position and the distribution of powers throughout the system.

No matter how far we stop the lens, the distortion will remain unaffected. This aberration cannot influence the sharpness of imagery. Distortion, however, is more sensitive to image height than any other aberration we shall consider, varying as the cube of the height; whereas coma and lateral chromatic aberration vary directly, and astigma-

tism and field curvature, as the square of the image height (Fig. 16).

Distortion is a very important aberration where the metric properties of the negative or print must be considered, as in copying, template work, or aerial mapping. In these cases, symmetrical lenses are usually used, which have the advantageous property of having theoretically zero distortion when working at unit magnification, and very little while working at any other magnification. When measurements must be made on photographs, the distortion of the lenses used is determined and allowed for.

In most photography, distortion is of small consequence, having been brought to such a level in modern lenses that highly-refined tests must be employed to detect it. For that reason, it is seldom seen in our negatives and prints.

The Two Pure Color Aberrations

Each of the preceding aberrations will differ in different colors, but there are two distinct aberrations arising because of color itself, two aberrations independent of any consideration except color. Before we discuss these chromatic defects of lenses, we shall have to consider in more detail exactly what happens when a ray of light strikes our lenses.

In empty space, light travels at the rate of 186,000 miles per second. When traveling in matter (transparent, of course) the speed is necessarily somewhat less. In fact, the velocity of a light-wave is one of the most important characteristics of a transparent medium (vacuum having the maximum and optically more dense media having progressively lower velocities). This velocity is a measure of the bending or refractive power of a medium: the lower the speed of light inside the medium, the greater is its ability to bend light, and *vice versa*.

The reason for this is seen in the consideration of the diagram illustrating refraction for a beam of light. Upon the basic fact of refraction at a glass-air boundary, or the boundary of two dissimilar media, is raised the whole science of optics as it interests us here (Fig. 17).

Refractive Index of Media

Nature, doing things with a lavish hand, not only permits slowing light upon entering a dense medium, but permits different colors travelling with different velocities. In fact, in common glasses,

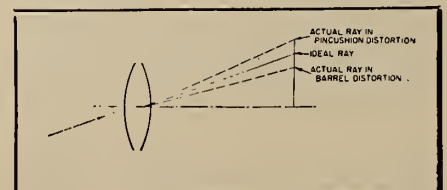

FIG. 16. Distortion.

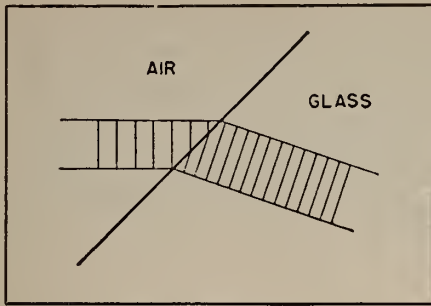

FIG. 17. Refraction.

red light travels as much as 4000 miles per second faster than violet or blue light. This has the natural effect of tying the bending power or *refractive index* to the color of the light considered, which means a different index for red than for violet light (Fig. 18).

The index for blue light is always higher than for red light, the difference between the two expressing the dispersive power of the medium, since it measures in effect the spread of a spectrum, or rainbow, produced by a prism of the material.

Now consider a lens receiving a bundle of parallel light. Each element of the lens acts as a prism, refracting the light toward a general region on the axis (Fig. 19). For the moment, neglect spherical aberration and consider the effect of the colors constituting white light.

As noted previously, blue or violet light will be refracted more than red light, and would thus be brought to a focus closer to the lens than would the red. The distance between the lens vertex and the mean focus is dependent on the glass index, being smaller the higher that index. The distance between the blue and red foci is a function of the dispersion of the glass, being greater the larger that dispersion.

This difference of focal points in different colors constitutes the first of our

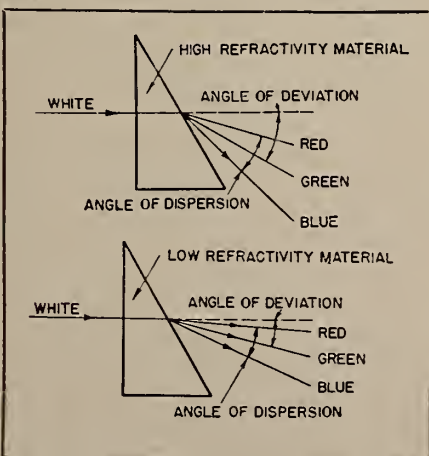

FIG. 18. Refraction and dispersion.

chromatic aberrations: *longitudinal chromatic* aberration, or separation of focal point. It is easily seen that this defect is of major importance in photography, for, as is seen from the diagram, in the presence of this aberration there is no single focal point: the image is soft, consisting of vari-colored discs.

The situation would not be too bad with blue-sensitive film, for then, after a shift to compensate for the "chemical focus," a fairly sharp image could be obtained in blue light (Fig. 20). If either orthochromatic or panchromatic film were to be employed, the situation would be hopeless, the film registering little but the large circles of confusion.

Chemical focus is seen in infra-red work, where the manufacturer recommends focusing the lens out a trifle for

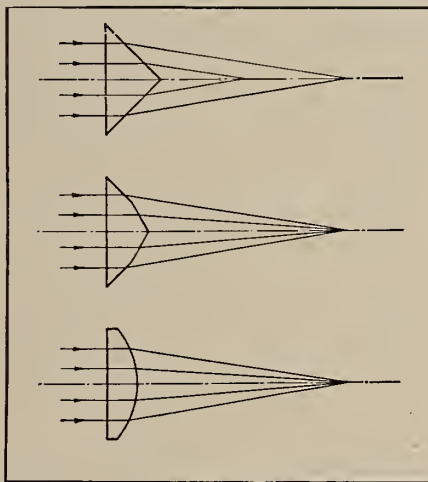

FIG. 19. Lens as prisms.

best results. The infra-red focal plane is farther from the lens than the visible, *i.e.*, the lens is afflicted with longitudinal chromatic aberration in the infra-red, and the outward shift is to compensate for this.

This aberration justly receives prompt attention from the designer, being one of the very first to be corrected. All photographic objectives except the very crudest have been corrected for longitudinal color.

We saw previously that, because of the twin factors of refraction and dispersion, a parallel beam of white light is broken up by a positive lens into a series of focal points, the blue coming to a focus sooner than the red. Further, we saw that the distance between these two foci varies with the dispersion of the glass, being greater the greater the dispersion. The only way to achieve *achromatism* of the focal points is by some dodge to annul the dispersion of the glass, while at the same time not completely canceling its refractive power.

In practice, this is achieved through

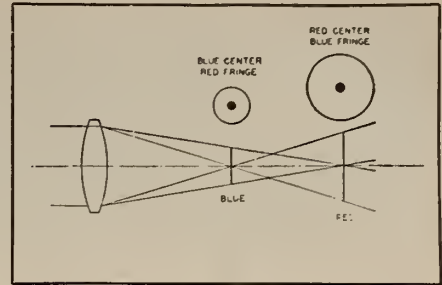

FIG. 20. Longitudinal chromatic aberration.

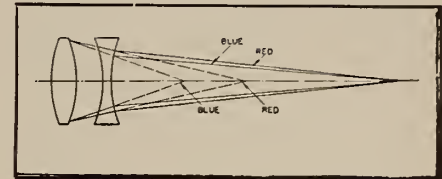

FIG. 21. Longitudinal achromatization.

the expedient of using a negative lens of a glass of higher index and dispersion with the positive lens (Fig. 21). The negative element has its power and dispersion so chosen that the dispersion between two chosen colors of the positive element is effectively cancelled, while its power is not quite annulled: thus, a real focal point does exist for the two colors achromatised. In doing this, the spherical aberration of the combination is usually corrected through the expedient of "bending" the lens—that is, changing all the curves by the same amount.

It is to be noticed that we have spoken of achromatising the focal points for two colors only. Unfortunately, it is possible to correct with two lenses but for only two colors. The slight amount of *secondary color* inevitably left in even the best objectives is too small to be of much concern. The focal points of the colors not specifically achromatised usually lie fairly close to the common focus of the colors for which the lens was corrected.

But it is not sufficient to provide a common focal point for light of various colors. True, with this axial achromatism effected, a sharp image will be found in all colors on the axis; but off axis there might be a color fringe about objects. Let us see how this might occur in a lens having a common focus for blue and red light (Fig. 22).

We saw earlier that the equivalent
(Continued on page 24)

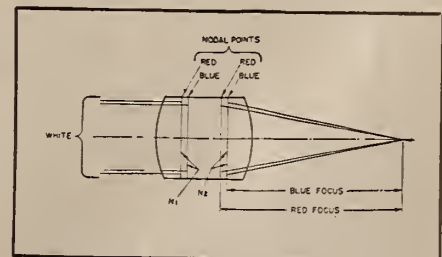

FIG. 22. Lateral chromatism. I.



TELECASTS

Feverish Tv Activity on all Fronts; Theater Stake

BRASH indeed is anybody who would hazard a prediction as to the ultimate significance of Tv developments on both the home and theater fronts within the past month. But even a straightaway recounting of such happenings is enough to excite the imagination.

First, the word about that old theater Tv standby—prize fights. The Robinson-Turpin exclusive fight broadcast was a tremendous success in every theater where it was shown. In fact, in a couple of spots the crowd got a bit unruly—notably at the State-Lake in Chicago, where a surging mob crashed through the lobby doors and grabbed whatever seats were available. This gave industryites no little concern in terms of its effect upon their regular patronage for movies.

Sports Promoters' Bonanza?

The film industry then delivered another sock at home Tv when RKO had 300 film prints of the fight in theater circulation within 24 hours. Theater Tv plus theater film, with its lush take practically convinced sports promoters of the desirability of mixing home Tv-radio broadcasts.

Two weeks later the Pep-Saddler brawl did not do so well on the theater Tv circuit; but the optimistic view in film circles was that the seating capacity of Tv theaters now operating is 2½ times the seating capacity of the Polo Grounds, N. Y., where the fight was staged. Tending to prove that it still is a basic question of a quality attraction—"the show's the thing."

Scores of Tv Color Tubes

Theater Tv equipment manufacturers were feverishly active. Paramount (intermediate-film system) appointed Century Projector Corp. exclusive distributor of its theater units. Paramount also pulled a fast one when it produced in New York a world-famous atomic scientist, Nobel-prize-winner Dr. E. O. Lawrence, of the Univ. of California, and demonstrated a "revolutionary" new color tube. Oddly enough the first demonstration was given exclusively to science writer William Lawrence, of the *New York Times*, who wrapped up the first atom bomb story for all newspapers on behalf of the U. S. Government. Nice going anent personnel and timing, with Par stock rising six points the day following.

Strangely enough, writer Laurence was present the following day at a demonstration of the RCA color tube, and he rather surprised the assemblage by declaring that the RCA tube was the better of the two! Paul Raibourn, Paramount v.p., "admitted" that the RCA tube was "just as good as ours," but that the Par tube was "cheaper to make."

In passing, it may be said that the Lawrence tube is not "revolutionary." In fact, there are more than 50 different ways to make such a color tube; and back in 1940 Dr. A. N. Goldsmith invented 20 different ways, while disclosing up until recently only three of them.

Meanwhile, Spyros Skouras, 20th Century-Fox prexy, hied himself to Switzerland for a further look-see at the Eidophor Tv system, which utilizes the Ventarc H-I "blown arc" of Dr. Gretener (IP for July, 1950). Skouras, enthusiastic anent Eidophor, says that Fox will soon be merchandising this system.

Tv Scores at TOA Meeting

Theater Tv stole the show at the recent Theater Owners of America convention in N. Y. RCA, Paramount, General Precision Labs., and Trad-Tv Corp., the latter pushing a set for the smaller theaters, went all-out to impress Mr. Exhibitor. RCA (direct-projection) said that it had a backlog of 100 orders which, at the present rate of production, it expects to deliver by Jan. 1 next. This system costs \$16,500, plus about \$2000 installation expense. Paramount has 10 of its intermediate-film equipments in work, with delivery date uncertain. This equipment costs \$25,000, plus \$2000 for installation.

GPL reports 43 orders on hand for its two systems, this company being the only one to date to offer both intermediate-film

Tv Stations vs. Saturation

Confirming general observation, recent statistical studies have shown that in markets where there was only one television station, the average Tv receiver saturation was 28.7%. The saturation figure goes up to 33% in markets with two stations; to 46.3% in markets with three stations, and climbs even to 59.1% in markets with four or more.

and direct-projection equipments. The film equipment, similar to the Paramount unit, is priced at \$35,000, but since 16-mm film is used *via* a special projector, GPL claims radically decreased operating costs. The GPL direct system costs about the same as the RCA job, with production now underway.

The newcomer to the field, Trad, is offering a simplified system which is obviously pointed at the small-theater field. Two Trad units are available—one at \$3500 and the other at \$7650, with installation costs estimated at under \$1000.

Significantly, practically all sponsors of theater Tv systems predict that the movie theaters will have color Tv *via* a closed circuit long before it ever reaches homes on a large scale. Paramount, through its Chromatic subsidiary, avers that color Tv is a cinch right now; while Fox asserts that not only will its Eidophor system run first in the color derby but will also give the best color rendition.

RCA Theater Tv Color Show

RCA made a quick decision in favor of action, not words. It hastily organized a full week's showings of *large-screen, color theater Tv* at the 1200-seat Colonial Theater (N. Y.). Viewed on a 9 x 12-ft. screen, a 20-minute show built around musical comedy actress Nanette Fabray was shown to very good advantage *via* the three-color compatible, all-electronic system. Morning show, in fact, was seen locally in black-and-white on home sets over Channel 4, as well as in Washington, D. C., on the same channel number there, *via* coaxial cable and radio relay. Further, color Tv receivers were set up in the lounge of the Center Theater in Radio City where the public was invited.

Color Tv Projection Unit

The experimental receiver-projector was set up in the orchestra, about a dozen rows back, while the audience sat in the balcony. It was explained that it would now be possible to obtain a greater thrust on a larger screen with more recent developments which could be incorporated into new models, and that widening the 6-megacycle band would result in greater definition. Moreover, the brightness could be doubled, RCA engineers present stated.

Projector housing contained three separate projection kinescopes—for red,

blue and green—with three images passing through correction lenses and then synchronized on the screen. In general, reception was comparable to home Tv reception: closeups showed well, while backgrounds blurred too easily. Audience reaction was obviously quite sympathetic with the few mechanical shortcomings, however, and was generally enthusiastic about the color values.

At the TOA convention it was disclosed that the film industry is seeking assignment of six channels in the 6000-megacycle range, far above the radio and Tv bands, which will enable color transmission. The request will be on a strictly commercial basis in that admissions can be charged.

Described by Sam Pinanski, retiring TOA prexy, as a "showmanship approach" was the suggestion that regional theaters finance their own productions of whatever character—musicals, fights, operas, football games, etc. He added that it is costing him \$400 a month to keep the Tv wire in the Pilgrim Theater, Boston, whether it is used or not.

National Theaters (West Coast) has

explored this idea and estimates that it would cost \$3,750,000 to connect 52 of its theaters, with all necessary broadcasting and production layouts.

Requisite Transmission Facilities

Transmission facilities are a major problem. A. T. & T. is not equipped at present to extend its service for the present type of theater Tv, but it is expanding its facilities rapidly. Microwave relay is favored over coaxial cable to handle several groups of wavelengths more readily. The addition of new cities to Tv theater connections will require local terminal exchange facilities, and for these A. T. & T. wants \$28,000 for each of these, *provided* there is definite assurance of future business.

Film exhibitors continued to view with great concern the dogged fight being waged by proponents of the pay-as-you-watch system of home Tv. Nor are Phonovision and Skiatron the only entries in this contest: Paramount is one of the most avid supporters of coin-in-the-box Tv, while RCA announced two months ago that it had perfected such a system

and was set to go whenever the others were—FCC approval being requisite, of course.

Manufacturers of home Tv sets scanned all this theater Tv activity with a jaundiced eye, moving quickly to recapture major sports events and other attractions through the appointment of a committee to study methods for attaining this objective. Report has it that a voluntary payment based on set sales will be made by all manufacturers to finance a huge war chest to fight the theater Tv'ers. (The RTMA denies this.)

The Legislative-Legal Front

The most explosive development of the month was on the legislative-legal front. Many thousands who believe that they have a "vested right" to see *for free* in the home all major sports and other attractions (the claim being that this was implicit in the Tv set sale) deluged local, state and national authorities with complaints that theater Tv, pro and college football management, baseball clubs, etc., were depriving them of their "rights" when they restricted broadcasts.

Legislators on all three levels, their ears acutely attuned to the great publicity possibilities inherent in the situation no less than in the imminence of the 1952 elections, promptly got busy. All sorts of "corrective" actions were suggested, ranging from the imposition of a special tax on such showings to prodding the Dept. of Justice to bring an anti-trust suit on a monopoly charge.

Evidently Justice was impressed, or the politico's wishes prevailed, because an anti-trust suit was filed against the National Football League in an attempt to break up restrictions on the broadcasting, radio and Tv, of the games. The Dept. of Justice said that the action was not aimed at theater Tv, but added "If we win here in our strongest suit, and if the shoe fits anywhere else, they will have to wear it."

Newspapers Cold to Theater Tv

Meanwhile, it appeared that a large group of newspapers, and particularly those who have radio and Tv station holdings, were giving theater-Tv showings the brushoff publicity-wise. In several cities where the Robinson-Turpin fight was piped into theaters, the sports pages of the newspapers gave not an advance line to the fight itself, much less to the fact that it could be seen at a local theater.

Thus, the muddled Tv picture at this writing. One thing is certain, however: all these happenings will breed such confusion of thought in the mind of Mr. Exhibitor that he will be very reluctant to lay \$25,000 and more on the line for something that might not pay off.

Tv: Time for Reappraisal

The appended penetrating commentary on Tv was penned by one of the best-informed men in show business—Abel Green, editor of Variety—and is reproduced here by permission of that publication, the "bible" of show business.

IN A relatively short period TV has started to pall. Video fans air the same gripes about the mediocre programs after two years as they did about pictures after over a quarter-of-a-century. Films are marking a box-office comeback; Tv is standing still, if not retrogressing.

Video is in for some serious soul-searching and self-examination. The sooner the better. Too many programs are NSG. Audience reaction is lethargic or negative—certainly not as enthusiastic as in the first flush of Tv.

The Show's the Thing

Since the show's the thing, neither a microwave-coaxial nor color will gild a wilting lily. If you've got the attraction, you can put it in Siberia and they'll seek it out; if it's a medley of mediocrity, it can stand smack on Times Square and catch only the breeze of customers passing by.

Showmen don't need any expositions on what's happening with Tv as of the moment—or, rather, what is not happening. Formulas are the same, be they the high-powered comedic programs or the relatively penurious panels.

Unfortunately for the medium, the impact is so socko that the audiences soon tire after absorbing so much. In some instances the viewers have literally become contemptuous through familiarity with the program content unreel week after week. The eye absorbs so much and so fast that the reservoir of fresh material becomes an almost physical and creative impossibility.

Radio was different—the imagination through the appeal of only one faculty, the aural, maintained greater interest over a longer period of time. Tv is a combination of the aural and the visual, and both faculties reject after a short spell what they first eagerly accepted.

Ratings No Longer Valid

Ratings are no longer a criterion. They only indicate that the number of viewers is the same because of the constantly replenishing new set-owners. It also means that sets in use are *not* the same, because the vet video fan has gone back to pix or gone out of the house for other entertainment. Ratings certainly don't tell of the many tune-outs on programs of late—and this goes for the biggest shows.

It's a challenge therefore, to the new medium's showmanship if Tv is to maintain its potency. It certainly indicates a necessity to dare to do the different; to explore new avenues and channel new talents for that iconoscope. There's a limit to comedians, variety shows, ballets, whodunits, panels, quizzes, parades. That limit is being reached. In some instances it's near the deadline.

Sponsors happy over trademark identification won't be so happy if it gets around that the lookers ain't looking. Tv, like radio, is still a medicine show with electronics. If they're not selling nostrums, the pitch is for something else, but whatever the sugar-coating it is pertinent that the lure had better be potent or they won't stick around for the commercial.

At least the picture business sells nothing but entertainment. If the film's value isn't there, they don't lay it on the line—as has happened until Hollywood buckled-down-Winsocki and started turning out the recent crop of quality celluloid. Tv is in the same hazardous position, which is the more dire in portent considering the relative infancy of the medium.

The Movies' 'Lost Generation'

Statistics *per se* have become the bane of our age, particularly in merchandising, mainly because they involve the use of figures in the mass which, broken down anyway the statistician wishes (always with the client in mind) never benefit by a look-see into the motivating factors in the individual mind. The motion picture industry has suffered acutely from this statistical t-error.

For what it may be worth, we append here the latest statistical roundup relative to box-office anemia as supplied by *Business Week*, organ of and for big business.

Age Group as Moviegoers

The ages between which people attend movies most frequently are 19 and 25. The war drew off a hefty part of this group. Toward the end of the war, vast numbers of people in this group got married immediately. Soon most had children. For the price of admission plus the price of a baby-sitter, you could make a week's payment on a refrigerator—or, later, a Tv set.

In 1945 there were 1.6 million marriages. In 1946 there were almost half again as many—2.2 million. And within the two years between 1945 and 1947, the birth rate had sky-rocketed from 2.8 million to 3.8 million.

Also, about 70 of all marriages take place between the ages of 18 and 24. And the average marriage age, in the U. S. is 23 for men and 20 for women. In other words, the sociological phenomenon of widespread marriage right after the war left a real boxoffice vacuum. (One significant exception: the drive-in theater, where parents could skip paying a baby-sitter by throwing the kids in the back of the car.)

New Crop of Movie Fans

Both the birth rate and marriages are still running at a good clip—though not as high as immediately after the war. But now every day more and more kids are getting to the moviegoing age. These are children born in the 30's.

Indirectly, Tv may actually be contributing to moviegoing now. The new generation has grown up enough by now to be interested in courting. Tv keeps the family in the living room, which rules that out for courting. So the movies get the youngsters' trade.

Brokers See Steady B. O. Upbeat

The motion picture box-office upturn is more likely to gain momentum than not, according to a research department bulletin of Paine, Webber, Jackson & Curtis, N. Y. stock brokers. Survey points out that a more normal share of the consumer dollar should be available from now on, with hard goods competition beyond its peak, and installment purchases resulting from the post-Korean scramble for goods due to be liquidated by next Spring.

As to Tv competition, the bulletin points out: "The novelty seems to be

wearing off—and the talent voraciousness of Tv probably means an average level of program quality which can't compete with a really top-notch motion picture. When the public gets bored, America's gregarious urge manifests itself—and more often than not this means 'going to the movies.'"

Bulletin remains that notwithstanding the over six million more Tv sets in use today than a year ago, the trend of motion picture attendance turned upward in the Summer months, with the upturn continued through September, despite the return of top Tv shows to the air.

Hoff New Prexy of TESMA

The Theatre Equipment & Supply Manufacturers Assoc., at its recent annual convention in Hollywood, elected J. R. Hoff (Ballantyne) to succeed Oscar Neu (Neumade Products) as president. Also elected were Roy Boomer, sec.-treas., and as directors Harry Strong (Strong arclamps); W. C. DeVry (DeVry Corp.); W. B. Gedris (seating); Larry Davee (Century Projectors); Jack O'Brien (RCA); V. J. Nolan (National Carbon); E. W. Wagner (signs); Fred Matthews (Motiograph, Inc.); Clarence Ashcraft (Ashcraft arclamps); and Ben Adler (signs).

Ozone Biz Up 35% Since Jan. 1

Drive-in business is up 35% since the first of the year, running well ahead of regular four-wall houses which generally have shown an increase up to 10%

Technology on the March

- New cooling technique for electric transformers may reduce weight by one-third, step up power handling ability, reports Westinghouse. Nozzle sprays liquid fluorocarbon on hot core and coils, liquid is vaporized and vapors condense on cooling surfaces of transformer tank.
- Lightweight storage battery that will start a car at 65 degrees below zero, developed at the Univ. of Michigan Research Institute, is expected to have wide application. Lead plating of materials ordinarily corroded by sulphuric acid makes replacement of much lead now used in batteries possible.
- High-voltage electron-beam sterilization on a production-line basis is economically practical, states High-Voltage Engineering Corp., Cambridge 38, Mass. Process uses Van de Graaff accelerator, is said to be safe, dependable, non-injurious to food and other products.
- New aviation gasoline additive reduces spark plug fouling, reports Shell Oil Co. Failure of spark plugs comes from electrically-conductive deposits which short-circuit

for the similar period, according to a spot survey of domestic revenue figures of the major film companies.

Ozoners, therefore, would appear to be relatively safe from the Tv "bogeyman" at this time. More important, however, according to one distribution chief, the 35% figure indicates that drive-in theaters are either bringing back the "lost audience" to the movie-going habit, or are possibly serving as the lure for patrons who have never attended a movie before.

Sub-Standard Equipment—40%

Upwards of 40% of film theaters today are not maintaining proper equipment standards, according to the report of a special committee at the recent TOA convention. Time for correcting this situation is now, the report stated, because it appears that material shortages will get worse before they get better.

All essential equipment units are now available, but the situation may change radically within the next several months. Stress was laid on the necessity for pushing the carbon arc copper drippings program to the limit, so that not a single pound of the metal is overlooked.

Tax Take Shows B. O. Advance

Official statistical backing of claims for increased box-office returns in the second half of the year was supplied in the Internal Revenue Bureau report

it; new ingredient reduces fouling by changing nature of deposit so that it does not become conductive.

- Ball bearing-type microscope, developed by Bausch and Lomb, is said to offer easier, more critical focusing and longer instrument life. It features ball bearings and rollers within focusing mechanism and pressure-loaded ball bearings around rim of nosepiece.
- Improved transistor, tiny amplifier that occupies 1/400 as much space as a vacuum tube and can do the same job, announced by Bell Telephone Laboratories, New type has uniform performance, will get trial use next year.
- "Does all research pay off? I wish it did," said C. H. Greenwalt, DuPont president. He estimates that one of 20 projects yield a profit.
- About 150,000 technical reports have been collected by the Office of Technical Services, U. S. Dept. of Commerce, Washington 25. Prepared lists of reports on some 50 major fields of interests are available, most of them free of charge. OTS describes collection as so great in scope that it remains largely unexploited, invites written inquiries.

ARMOUR RESEARCH FOUNDATION.

of admissions tax collections for August, reflecting business done in July.

IBR reported that general admissions tax collections in the month were \$34,142,531, compared with \$31,606,356 for the same 1950 period. Achievement marked the first month since February—January business that tax collections were ahead of the comparable month of last year. It is estimated that 75% of admissions tax collections are from motion picture theaters.

Printing Color Tv Plates?

In a New York print shop experiments have been conducted for RCA, looking to mass production of color-tube plates. Patterns of small dots were printed on glass sheets, using rubber plates, employing three types of phosphor pigments, similar to printing three-color pictures. Each set of dots was not to coincide with any of the other sets of dots.

These experiments were successful, from the printing standpoint, and a number of such printed-phosphor glass plates were made. Other experiments were then carried on to do similar printing via the silk-screen process. The phosphor pigments used in printing were supplied by RCA. In daylight, all the material was white to the naked eye, but was said to glow blue, red and green, according to its type.

Are There Four Retinal Colors?

The textbooks have long agreed that the human eye can detect only three colors—red, green, and violet; that we have no retinal receptors sensitive to yellow. But now, before the American Association for the Advancement of Science, Dr. L. M. Hurvich of the Eastman Kodak color-control department, Rochester, N. Y., reports experiments indicating that impinging "pure red" on one retina and "pure green" on the other, combine to produce white, while "pure yellow" radiation gave a yellow sensation.

He testifies that there is no binocular fusion which creates yellow out of pure green and pure red, but that the eye can see yellow alone, indicating the presence of yellow receptors.

A.S.A. Acoustical Dictionary

The recording and reproducing industry now has an authoritative dictionary of terms compiled by experts in the acoustical field. This document—the latest edition of the A.S.A. Terminology (Z24.1—1951)—has just been published by American Standards Assoc., 70 East 45th Street, New York 17, N. Y. (Price: \$1.50).

For the first time, more than 150 terms used in connection with mechanical, photographic, and magnetic recording are printed and defined in one document. Various types of instruments used and the various kinds of noises produced are defined. Until recently most of the language used in con-



more
B.A.*

*(BOXOFFICE
APPEAL)

MOVIES
ARE
BETTER
THAN
EVER

with **SUPER SNAPLITE**

f/1.9 projection lenses

● GREATER LIGHT ● GREATER CONTRAST ● GREATER SHARPNESS

Watch your "B. A." climb when you install Super Snaplite Lenses. Give your patrons the benefit of pictures at their best. You can't beat the Super Snaplite f/1.9 when it comes to putting a clear, sharp picture on your screen.

Super Snaplites give you a true speed of f/1.9 in every focal length up to 7 inches. Ask for Bulletins 207 and 209.

"You Get More Light with Super Snaplite"



KOLLMORGEN

2 Franklin Avenue
Brooklyn 11, New York

Optical

CORPORATION



nection with magnetic recording was slang. Now most of the terms are correlated and presented with standard definitions agreed upon by experts.

Inclusive Range of Topics

Definitions for sound recording and reproducing systems; instantaneous recording; frequency response equalization; mixer; magnetic recording; magnetic powder-impregnated tape; magnetic wire; magnetic recording reproducer; erasing head; double pole-piece magnetic head; magnetic biasing; light modulator; galvanometer recorder; multiple sound track; variable-density track; opacity; photographic transmission density; H and D curve; noise reproduction; mechanical phonograph recorder and many others are included in the standard.

This edition also contains a table giving the conversion rate of present acoustical units into the meter-kilogram-second system (mks units) now being used more and more by physicists and electrical engineers. Also,

there are sections on hearing and speech, sound transmission and propagation, transmission systems and components; ultrasonics, music, shock and vibration, underwater sound, general acoustical apparatus, and architectural and general acoustical terms.

Extreme Temperature Range Film

How to make photographic film that will not get brittle and crack in Arctic cold and will also be good in tropic heat is indicated in a signal Corps research report, now available, the U. S. Dept. of Commerce has announced. To get film which would stand up in the hottest Tropic and coldest Arctic regions, the Signal Corps directed Armour Research Foundation to develop photographic film bases which would have "good dimensional stability, optical clarity, low moisture absorption, constancy of composition, good aging qualities and ease of fabrication" over the entire temperature range from -65°F . to 140°F .

PHOTOGRAPHIC OPTICS

(Continued from page 19)

focal length of a lens is defined as the distance from the second nodal point to the focal point in parallel light, and that this length is seldom equal to the distance from the rear lens vertex to the focal point. The back focus is, in

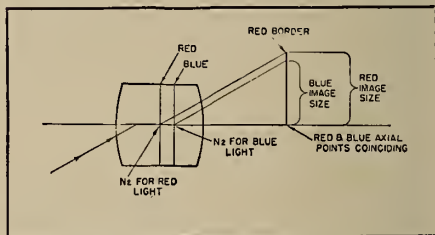

FIG. 23. Lateral chromatism, II.

fact, what we have achromatised as the first step in color-correcting our lens.

We have not assured the same focal length in the two colors, blue and red; in point of fact, it will usually differ with color. Just what effect does this have on the imagery from our lens?

Size of the Image

We saw previously that the size of an image is dependent on two factors: the object distance, and the focal length of the lens. It is clear, then, that if our lens possesses focal lengths different in different colors, it will produce images of varying sizes in those colors. It is for this reason that the second chromatic aberration is called *chromatic difference of magnification*, or lateral color, since a lens afflicted with this aberration will produce a larger red (blue) image than blue (red); or in white light, points in the field will be pulled into rainbows (Fig. 23).

Obviously, this aberration is independent of longitudinal color, since the

ONLY Century PROJECTORS HAVE EVERYTHING

4-inch diam. lens mount

Water-cooled apertures

Oil-less Bearings

CENTURY'S high-efficiency projector with the NEW 4-inch diam. lens provides pictures of increased brightness and appeal—for even the largest drive-in screens.

CENTURY'S water-cooled aperture gives as much light with a 90 ampere arc as other projectors using a 180 ampere arc and heat filters!—Reduce power cost—Get sharper pictures—Save film.

CENTURY'S sealed, oil-less bearings and glass-hard gears reduce maintenance costs. No oil sprays or baths to mess up film or projection room.

You can SEE and HEAR the difference!

CENTURY PROJECTION AND SOUND SYSTEMS
See your dealer or write for information

CENTURY PROJECTOR CORPORATION
New York, N. Y.

BUY U. S. SAVINGS BONDS

Your Very Best Buy

BUY U. S. SAVINGS BONDS

"World's Most Powerful Spotlight"

The METRO-LITE high-intensity carbon arc spotlight comes in two models:—

- ★ MODEL ME 4 125 Amps D.C. 100 ft. to 400 ft. throw.
- ★ MODEL ME 5 "Vaudeville" 60 to 85 Amps D.C. 75 ft. to 250 ft. throw.

METRO-LITE

Literature available on both units upon request to
GENARCO, Inc. 36-56 b 34th St., Long Island City 6, N. Y.

A GOOD FILM CEMENT MAKES A GOOD SPLICE

USE ETHYLOID Double Action FILM CEMENT AND YOU USE THE BEST

ETHYLOID makes hard to splice safety film EASY

ETHYLOID works FASTER—HOLDS and DOES NOT CONGEAL

ALL THEATRE SUPPLY DEALERS SELL ETHYLOID

Made in U.S.A. by
FISHER MANUFACTURING CO.
Manufacturing Chemists
1 Salter Pl., Rochester 13, New York

latter is concerned only with color correction of the back focus, whereas this is concerned with a different quantity, the equivalent focal length. It is further readily appreciated that for the best imagery a lens system must be corrected for both aberrations which involves two different methods.

Common Color Images

In the case of chromatic difference of focal points, we were able to effect correction very simply—by employing a negative lens whose characteristics cancel the dispersion of the positive lens, thus reuniting the dispersed colors. With the more troublesome lateral color, we are forced to use a trick illustrated in symmetrical lenses: using systems of opposing tendencies. Some system will yield a spectrum with the red higher than the blue; while others will reverse the order. The proper combination of these two types will yield a system giving a common size to the red and blue images.

Of course, each of the five aberrations considered herein has its own chromatic variant in the sense that its value in the different colors will vary. However, that variation is of a smaller magnitude compared with the two pure color aberrations we have been considering, and is of little interest to us here.

Summary of Aberrations

We have now seen that there are seven different types of defects which plague the lens designer, and which he has either to remove or to balance one against another in the design of a satisfactory photographic lens. They fall naturally into three different classes:

Those affecting the sharpness of images in monochromatic light: spherical aberration on the axis, and coma and astigmatism off axis; those affecting the position of the sharp image points, and distortion, effecting lateral position on field magnification; and third, the two chromatic aberrations: axial, affecting the focal positions in different colors, and lateral, influencing the magnifications in different colors.

It is often said that because of the increasing use of color photography lenses will have to better corrected in the future. There is but a shell of truth in this statement, for it cannot be denied that a simple positive lens designed for use in conjunction with unsensitized, or orthochromatic, film cannot yield satisfactory images in color where automatically one is critical. The assertion is true to just that extent.

It should be clear from the preceding discussion that color photography introduces nothing new in the way of performance demands on lenses, the only difference being that with color film the aberrations can be seen as color, and not

RCA Service protects your Box-Office

—By guarding the HEART of your Theatre



PROJECTION... SOUND

...AND RCA SERVICE

It costs so little to protect so much

The advantages of RCA Service are yours at a cost so low, a few admissions daily pay for it. Write for complete information.



Sound and projection equipment (*the heart of your theatre*) will wear out through continuous performance, unless the equipment is protected by periodic checkups and preventive maintenance.

Guard your equipment . . . protect your box-office with *complete* RCA Service Coverage. RCA Service is more important today than ever before.

The possible scarcity of new sound and projection equipment . . . even replacement parts . . . makes it important that you protect the life of the equipment you now have. Coming events may require you to keep your equipment in operation for a much longer period than you plan. Prepare now for the future while replacement units are still available.

RCA Parts Plans cover all makes and types of theatre sound equipment, as well as projectors and accessory units. RCA Service protection is more vital today than ever before.



RCA SERVICE COMPANY, INC.

A RADIO CORPORATION of AMERICA SUBSIDIARY
CAMDEN, NEW JERSEY

CLAYTON BALL-BEARING EVEN TENSION TAKE-UPS

For all projectors and sound equipments

All take-ups wind film on 2, 4 and 5 inch hub reels.

Silent Chain Drives

THE CLAYTON REWINDER

For perfect rewinding on 2000-foot reels.

CLAYTON PRODUCTS CO.

31-45 Tibbett Avenue

New York 63, N. Y.

as a blob or blur casually ascribable to some other cause. The best lenses have always been "fully color corrected." However, a continual improvement is being effected in lenses for all the aberrations, and our children's lenses inevitably will be better than ours.

[THE END]



• The NEW, improved, positive method of permanently patching all types and makes of film—8mm., 16mm., 35mm., Trucolor, Technicolor, Kodachrome, Nitrate and Safety Film.



Used and endorsed by Projectionists in countless theaters.

specifically for *lasting Patches.*

ESSANNAY ELECTRIC MANUFACTURING CO.
Chicago 10, Illinois 1438 North Clark Street

'SHOWBOAT' CAMERAWORK

(Continued from page 15)

museum. More than 300 feet in length, it was just the prop we needed; so arrangements were made with the owners to use it for the picture.

The most important shot for which it was required was a scene—a long shot—showing it moving up the river at dusk, its cabin lights ablaze and passengers promenading its decks. Now this shot easily could have been done in miniature, but needless to say not with the same authenticity. Inasmuch as the cost would have been about the same, we decided to make the shot the way we did—using the real boat on the Mississippi.

Ingenious Lighting Set-up

A 300-amp generator was installed temporarily on the craft to supply power for the lamps that were to furnish illumination behind the windows. The boat's steam plant long ago having been sold for junk, it was necessary to provide temporary motive power. Two tugboats were made fast to the packet on the side opposite that which was to face the camera, to move it upstream while we made the shot.

Hundreds of photoflood lamps were

used to supply light back of the windows. Because it was necessary to secure every available foot-candle of light the lamps would give, in order to make the boat's interior appear brilliantly lighted, the lamps were mounted directly behind tracing cloth panels tacked over the boat's open windows. The lamps were placed so that the filament of each was directed as near as possible at the lens on the camera (which was set up on another boat some distance away), and with the filament at the same height as the camera lens. Only by doing this was it possible to secure the maximum volume of illumination from each lamp.

To obtain the desired pictorial result, Rosher calculated that the scene would have to be shot at precisely a certain time after sundown. It couldn't be ten minutes too soon or too late. On the previous evening he had made an exposure test at twilight to determine the correct balance between the artificial light, coming from the boat, and the waning daylight.

Ten Minutes—a Lighting Masterpiece

On the following evening, when the scene was to be filmed, there was no time for rehearsals. The reason for this was that the artificial light coming from the windows of the boat had to be the dominant light in the scene, yet exposure had to be ample to give a clear outline of the boat in the dusk, and consequently a rich print. The whole operation, once ready to shoot, required about ten minutes time—ten tense, anxious moments for all of us. No process shot could have equalled the result. It is truly a masterpiece of color photography.

In the beginning, we had considered shooting the showboat exteriors on location on the Mississippi. However, after long and careful search, which took us from New Orleans to Cincinnati, two things became apparent: there was not a boat on the entire river which met all our requirements and, most important, the Mississippi river currents were such that operating camera and lights from other craft on the river would have been almost impossible. So we decided to have the showboat built on the studio's back lot.

The finished craft, named the "Cotton Blossom," is the largest movable prop ever built on a Hollywood motion picture lot. It floats lazily on the lake in MGM's lot number three, awaiting future assignments.

Whereas shooting scenes on a boat on the Mississippi would have entailed lighting problems—and the inability in

ANSWER TO YOUR TECHNICAL PROBLEMS...



*The Altec
Service Man and
the organization
behind him*

The
Altec
Service
Man



161 Sixth Avenue,
New York 13, N. Y.

PROTECTING THE THEATRE—FIRST PLACE IN ENTERTAINMENT

Your Very Best Buy
BUY U. S. SAVINGS BONDS

many cases to maintain directional lighting continuity—with the studio built boat we were able to keep this factor under absolute control, simply by moving the boat and following the sun around as necessary.

'Weathering' the Showboat

When construction of the boat was completed and the painters had finished recoloring it, the result was a sparkling new boat just off the boatmaker's ways, instead of a weatherbeaten Mississippi river boat. Studio painters then applied "weathering" to its entire exterior and the photographic result is everything that could be desired.

This is but one example of the myriad of details which Rosher constantly surveyed from the photographic viewpoint, directing such changes or improvements as were necessary to achieve the photographic excellence for the production that was our constant aim.

While the photography of the vast number of exteriors involved the most interesting experiences, the interiors demanded no less attention from the camera viewpoint in planning and lighting. Perhaps it was because we had held many pre-production huddles with the art director on wardrobes and set decorations that camera problems on the interior sets were greatly minimized.

Subject-Background Separation

Care had to be taken against having costumes too somber in tone, yet not garish, either—so they did not merge and become lost in the background. There must be good color separation always between subjects and background to get the most pleasing effect in color cinematography. In this respect, we utilized a lighting trick worth noting. After the key light had been established, an additional light source was directed on other objects or on the background itself in order to gain the desired compositional effect. This is something that rarely can be determined by meters—one has to have it in him, intuitively.

Photography, I believe, has now become so popular, audiences have come to expect better camera work on the screen. That is why we made it a point to be so meticulous with the photography of "Showboat." Having educated the public to expect the best in photography, we now have to keep ahead of them. I think

we can say in all honesty that, because of all this, we are constantly improving the tastes of the people of the world, influencing their dress, makeup, their manners and also the graphic arts.

Being ardently interested in photography has brought me in closer understanding with the director of photography's problems, and from this has stemmed an invariable practice of consulting at great length with him during the course of preparing a picture for production.

A 'Director's Cameraman'

I like to think of "Showboat" as an example of the point I have often made that when a director and his cameraman both speak and understand the same language—the language of photography—superior motion pictures invariably result.

We often hear applied the appellation "cameraman's director"—meaning a director who works harmoniously with a cinematographer. Conversely, I think Charles Rosher is the epitome of the director's cameraman. His tremendous experience and wealth of photographic knowledge, his personal "bag-of-tricks," and his ceaseless enthusiasm and dogged perfectionism are qualities which contributed to the standout photographic job of "Showboat."

BRITAIN'S TELEKINEMA

(Continued from page 13)

its associated amplifier cubicle, the unit standing a few feet behind the associated projector.

Electro-Acoustic System

The electro-acoustic system is fairly conventional, with emphasis on wide frequency range and low amplitude distortion throughout the whole system. Any magnetic reproducer pick-up head has an output which over the major part of the useful frequency range is proportional to frequency, thus a large amount of frequency compensation is required to obtain a flat overall frequency char-



THE OPERATORS' FAVORITE!

GoldE's Automatic Enclosed Rewind Always Works! Silent, safe, U.L. approved! Eliminates fire hazard. Positive friction . . . can't clinch film. Tilt-back case . . . reels can't fly off. Microswitch safety cut-off . . . when door opens or film breaks, motor stops!

**AT BETTER THEATRE SUPPLY DEALERS
GOLDE MANUFACTURING COMPANY**
DEPT. IP. 1220 W. MADISON ST. • CHICAGO 7, ILL.

REEL-END ALARMS

Jackson's Patd. Automatic!

Can't Scratch Film! Foolproof!
Lasts a Lifetime! \$18.50 per pair

Order one from your dealer or write to

American Theatre Supply Co., Inc.
2300 First Ave., Seattle 1, Wash.



FOR WANT OF A NAIL...

YOU KNOW THE STORY: the horse, the rider and finally the battle was lost for want of a little nail.

WIN YOUR BATTLE AGAINST PROJECTION WEAR

Use only

GENUINE

Simplex
T.M., P.C., U.S. PAT. OFF.

PARTS

Equipment and Supplies for Every Theatre Need

NATIONAL THEATRE SUPPLY
Division of National • Simplex • Bludworth Inc.

Available for immediate delivery

acteristic. The main amplifiers have a power output of 20 watts per channel.

The five amplifiers (four channels plus one spare), the gain controls and control push buttons are mounted in the main amplifier cabinet, provision being made for a "switch interchange" between the center channel amplifier and the spare unit. Failure of any of the other three amplifiers requires the interchange of wiring plugs, a process that is greatly simplified by the method of mounting and the use of only two plugs for all

connections on each of the amplifiers.

The screen loudspeaker system is fairly conventional, each of the three channels using a standard combination of two-unit e-f horns and two-unit h-f horns with a changeover frequency of 500 c.p.s.

The screen speakers are used for all sound film, monaural or stereophonic, the Tv sound, the interval music, and if the original ideas had matured, for 16-mm sound also. To reduce the load on the projection room staff, selection of

the speaker system appropriate to the picture is made by a switching system incorporating non-linear resistors. Thus, on a changeover the projectionist on the outgoing machine turns his gain control to zero, gives an aural or visual signal to the man of the incoming machine, who has only to depress his "sound" push button to select the appropriate speakers.

These "sound" buttons are located on each machine in close proximity to the gain controls. A loudspeaker selector unit containing the changeover control circuits and the deaf-aid amplifiers is located adjacent to the right-hand machine. It carries indicator lights of different colors which show which speaker system is in operation.

Four monitor speakers of conventional design reproduce sound from the four output channels; those corresponding to the three sets of screen speakers being mounted on the front wall of the box, while the fourth, monitoring the auditorium sound effects, is mounted on the rear wall of the box.

Control System

When projecting stereoscopic films or using the magnetic sound heads it is essential to operate two or more machines in exact synchronism from standstill. Normal synchronous drives are insufficiently accurate to maintain such exact correspondence even though the films are correctly framed when threaded, but the application of a Selsyn interlock system makes it possible to obtain the synchronization necessary in a relatively simple manner.

Selsyns are similar to A.C. induction motors, with wound rotors and stators, the stator winding being energized from the mains, while the rotors of the two Selsyns to be interlocked are connected in parallel. The stator windings induce mains-frequency voltages into the rotor windings, and the two rotors move relatively until the voltages induced in the two rotors balance each other with no current flowing in the rotor circuit. If one rotor is turned mechanically, the rotor of the second machine will move to keep the same relative position, and this occurs even with the rotor turning at 1440 r.p.m.

The Festival requirements are met by mounting a Selsyn motor adjacent to each driving motor, the two motors being coupled by a roller chain drive. Correct phasing at standstill is achieved by supplying single-phase excitation to the stators before film threading commences, and on depressing the "start" push-button all interlocked units will run up in exact synchronism.

As the number of machines in operation depends on the program being pre-

NEVER HAS
Economy
BEEN SO
ESSENTIAL AS NOW!

THERE IS A LORRAINE CARBON TAILORED FOR
YOUR SPECIFIC PROJECTION REQUIREMENT

Send necessary projection equipment data to guide us in recommending the Lorraine Carbons that will do your theatre or drive-in projection job better and More Economically.

SLOW BURNING
SAVINGS IN POWER CONSUMPTION
SAVINGS IN MAINTENANCE

ECONOMIZE
WITH *Lorraine*
Carbons

Lorraine CARBONS, INC., BOONTON, N. J.

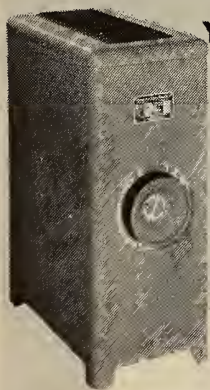

You Can't Buy
A GOOD
Rectifier
for Less!

Strong Rectifiers are the only rectifiers on the market which are especially designed, manufactured and tested in one plant together with and for use with motion picture projection arc lamps. This is highly important, as efficient operation of each type and rating of arc necessitates a rectifier specifically engineered to its particular requirements.

There is a dependable Strong Rectifier for every type projection lamp: 2-Tube • 4-Tube • 6-Tube • Single and Three Phase Models for

- Rotating Feed Angular Trim High Intensity
- Copper Coated Coaxial High Intensity
- 1 K.W. High Intensity
- Low Intensity

All assure smooth output current, long life, low operating temperature, and flexibility in control.

WRITE FOR LITERATURE OR FREE DEMONSTRATION

THE STRONG ELECTRIC CORP.
CITY PARK AVE. TOLEDO 2, OHIO
PROJECTION LAMPS
SPOTLIGHTS • RECTIFIERS • REFLECTORS



Each
A HELPING HAND

• SUPER •
LaVeZZi
• SERVICE •
PRECISION MADE
PROJECTOR PARTS

Once you've used them, you'll agree that the built-in precision and trouble free performance of La VeZZi parts do much to hasten repair jobs and help you to the better projection that delights patrons. Specify La VeZZi SUPER-SERVICE Parts for all your replacements! Your Theatre Supply Dealer has them.

LA VEZZI MACHINE WORKS
4635 WEST LAKE STREET • CHICAGO 44, ILLINOIS



Since
1908

sented, all the control switches are grouped together in a Selsyn selector panel, thus permitting the projectionist to verify at a glance the combination selected for operation.

Changeover Devices

The light and sound changeover devices on the standard equipment are electrically operated, depression of the "changeover" button on the incoming machine opening the "incoming" shutter and closing the "outgoing" shutter. This facility is retained in the Festival equip-

ment, but the arrangement has to be modified when projecting stereoscopic films, as both machine changeover shutters must open or close together. Appropriate arrangements ensure that switching of the equipment to the "stereoscopic" position automatically closes both machine shutters. During stereoscopic operation the normal changeover push-button operates both shutters in phase, i.e. they open together.

This completes a rather brief description of the Festival equipment, but it is probably true to say that it represents an advanced view of the projection room of the future, embodying some of the equipment that will undoubtedly prove essential if the kinema is to retain its present pre-eminent position.

PROJECTIONISTS FIND CURE FOR "CURTAIN IRRITATION"

No patent medicine will cure the sinking feeling projectionists get when they push the curtain button to start a show—and nothing happens.

That kind of "all-gone" feeling (which makes projectionists grow old before their time) requires a strong remedy—a remedy that consists of curtain controls, tracks and special operating devices that work properly all the time.

Specifically, it calls for Vallen equipment. For 35 years the products of Vallen precision engineering have served projectionists all over the world faithfully and well. The superior design and construction of Vallen curtain controls, tracks and special operating devices makes them all-time favorites of the men behind the show.

To make certain the front office sees eye-to-eye with them on this important subject, wise projectionists are putting copies of the latest Vallen catalog on their bosses' desks. You can do the same. Write today to

VALLEN, INC., Akron 4, Ohio.

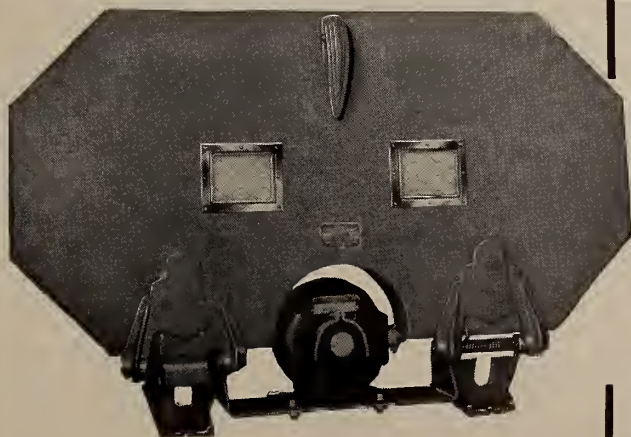

Wenzel's New Automatic Enclosed REWIND

PRO-62

Manufacturers of:
Projectors, Sound
Heads, Bases,
Magazines, etc.

WENZEL PROJECTOR COMPANY

2505-19 S. State St., Chicago 16

dous importance, not a single one of which may safely be overlooked.

Filter Transmission Data

Tremendous loss of screen illumination is a fatal defect of all additive color-projection processes.

Three primary-hued filter strips must be placed side by side over the projection lens in the proper optical plane, as previously mentioned. (This plane would probably intersect the lens barrel somewhere near the middle of its length, the filters thus being inside of the lens barrel.)

Each of these filters, if possessing



THE PRACTICE OF THROWING AWAY CARBON STUBS IS PROBABLY COSTING YOU THOUSANDS OF DOLLARS

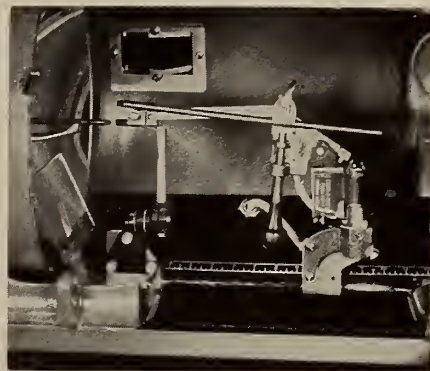

THE CRON-O-MATIC Fully Automatic CARBON SAVER

uses stubs of all lengths without any preparation. It's no longer necessary to guess whether or not a carbon stub will burn a full reel. No matter how short it may be, simply insert in the holder. When it is entirely consumed, the new carbon goes into use without losing the light. In no way interferes with the regular operation of the lamp.

Adaptable to Ashcraft "D", Brenkert-Enarc, Peerless Magnarc and Strong Mogul lamps. Only \$52.50.

PAYS FOR ITSELF 3 TIMES A YEAR!

Burns positive carbon stubs, which usually average 3 1/4" in length, down to a constant length of 3/4", to result in a net saving of 2 1/2" per carbon or 22.2% of the cost of the carbon, which for the average theatre actually amounts to \$150.00 per month . . . every month!

If your dealer cannot supply you, order direct.

Dealer Inquiries Invited

PAYNE PRODUCTS CO. (Cron-O-Matic Division)

2454 W. Stadium Blvd. Ann Arbor, Mich.

- () Please send literature on the Cron-O-Matic
- () Please ship Cron-O-Matic Carbon Saver
- () C. O. D., including postage
- () Remittance herewith.

Name _____

Theatre _____

Street _____

City & State _____

EXPORT: Frazar & Hansen, Ltd.
San Francisco, New York, Los Angeles

perfect transmission characteristics (which existing filters most assuredly do not), would transmit 1/3 of the light falling upon it, as reckoned on the basis not of actual "luminosity" but of color balance. Thus 2/3 of the total projection light is absorbed by the filters and converted into heat, reducing screen illumination to 33 1/3% of the illumination obtained without color filters. But as things actually are, the most efficient existing filters have approximately the following transmission efficiencies:

Vermilion	80%
Emeraude	40
Indigo	60

Because each filter represents one-

STATEMENT OF THE OWNERSHIP, MANAGEMENT, CIRCULATION, REQUIRED BY THE ACT OF CONGRESS OF AUGUST 24, 1912, AS AMENDED BY THE ACTS OF MARCH 3, 1933, AND JULY 2, 1946 (Title 39, United States Code, Section 233).

OF INTERNATIONAL PROJECTIONIST, published monthly at New York, N. Y., for October 1, 1951.

1. The names and addresses of the publisher, editor, managing editor, and business managers are:

Publisher: INTERNATIONAL PROJECTIONIST PUBLISHING CO., INC., 19 West 44 St., New York 18, N. Y.

Editor: HENRY B. SELLWOOD, 19 West 44 St., New York 18, N. Y.

Managing Editor: R. A. ENTRACHT, 19 West 44 St., New York 18, N. Y.

Business Manager: R. A. ENTRACHT, 19 West 44 St., New York 18, N. Y.

INTERNATIONAL PROJECTIONIST PUBLISHING CO., INC., 19 West 44 St., New York 18, N. Y.

R. A. ENTRACHT, 19 West 44 St., New York 18, N. Y.

3. The known bondholders mortgagees, and other security holders owning or holding 1 percent or more of total amount of bonds, mortgages, or other securities are: NONE.

4. Paragraphs 2 and 3 include, in cases where the stockholder or security holder appears on the books of the company as trustee or in any other fiduciary relation, the name of the person or corporation for whom such trustee is acting; also the statements in the two paragraphs show the affiant's full knowledge and belief as the circumstances and conditions under which stockholders and security holders who do not appear upon the books of the company as trustees, hold stock and securities in a capacity other than that of a bona fide owner.

R. A. ENTRACHT, Business Manager Sworn to and subscribed before me this 20th day of September 1951.

(Seal) ANNE CORRAGAN

Notary Public, State of New York, No. 31-5824300, Qualified in New York.

Commission expires March 30, 1952.

third, or 33 1/3%, of the total light (total color balance), use of these filters would result in 20% of standard screen illumination. (The V filter transmits 80 x 33 1/3%, or 26.66%, of 1/3 of the total light; the E filter 13.33%, and the I filter 20%, giving an over-all average of 20%.)

Filter Balance Requisite

However, this filter combination will not work!

It is mandatory that the three filters be balanced so that equivalent proportions of V, E and I light reach the screen (to give pure white light) when the projector is run without film. The transmission efficiency of each filter must be the same as the transmission efficiency of the least efficient filter! (In actual practice the emeraude filter happens to be the least efficient.) So, instead of the figures given in the foregoing tabulation, we must use the following:

Vermilion	40%
Emeraude	40
Indigo	40

This reduction in the light transmissions of the V and I filters will enable more satisfactory color reproduction to be obtained, because better V and I dyes can be used, but the screen illumination will be only about 14% of that obtainable with Technicolor and other non-lenticulated standard prints!

Enormous Light Increase

The lenticulated color-film process, therefore, demands projection lamps about 7 3/4 times more powerful than present-day lamps.

Can projector arclamps nearly 8 times

more powerful than those now in use be manufactured on a practical commercial basis? *Probably not.*

If such powerful lamps could be made, would exhibitors be willing to pay increased carbon and power costs merely to maintain levels of screen illumination which obtain now in theatres?

Is any present film capable of withstanding the terrific blast from lamps so powerful?

Would the theatre-going public accept a color process which is decidedly inferior to the least desirable color process in use today?

The answer to the three foregoing questions must be an emphatic "No".

This, then, is the sad, sad story of lenticulated color-film processes. The disadvantages of this process are obvious to everyone except a coterie of short-sighted producers who have the strange notion that color footage should cost not a penny more than black-and-white.

Existing Processes Superior

We already have natural color on our screens. Not enough of it, to be sure, but more and more of it all the time. Technicolor is regarded as the ideal color by all movie-goers. It is brilliant, clear, and faithful to the colors seen by the camera's eye. Agfacolor, Ansco-Color, Super-Cinecolor, among others, are close runners-up for top honors.

These processes are available to all producers who wish to employ them. There are no color processes, not even in the blueprint stage, which are in any way the equals of processes we already have.

How Many?

Was this copy dog-eared when it came to you? How many men read it ahead of you?

You would receive a clean, fresh copy if you had a personal subscription—and you wouldn't have to wait—you would be first to read it.

Use coupon below.

INTERNATIONAL PROJECTIONIST.

19 West 44 St., New York 18, N. Y.

Enter my subscription for 1 year—12 issues—\$2.50
 2 years—24 issues—\$4.00

Foreign and Canada: Add 50c per year.

Name

Address

City State

Medal of Honor

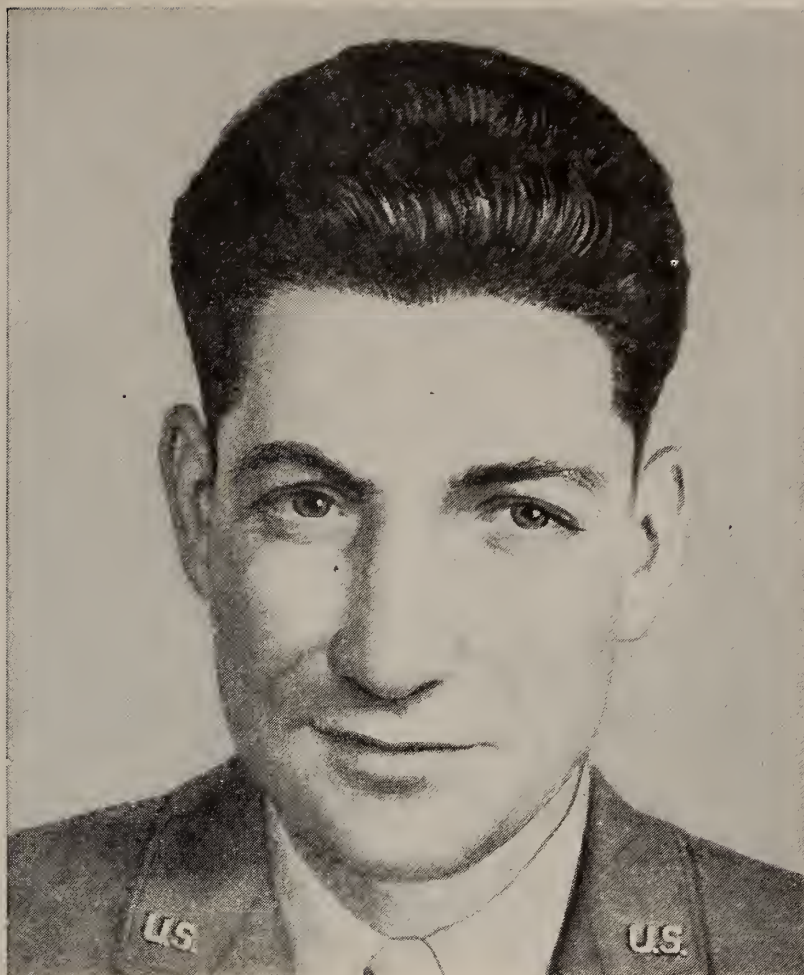
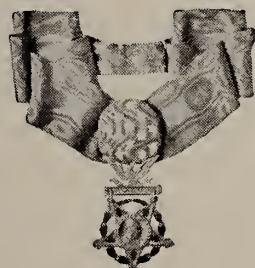

Lieutenant Frederick Henry of Clinton, Oklahoma—Medal of Honor for sacrificing himself to save his platoon in combat near Am-Dong, Korea, September 1, 1950. When the platoon could no longer hold its position, Lieutenant Henry ordered the men to pull back. But someone had to stay behind to provide covering fire. He chose to be that man, and was lost.

Always remember this—Lieutenant Henry offered his life for more than just a small platoon in far-away Korea. It was also for America. For you.

Isn't there something you can do when this man did so much? Yes, there is. You can help keep the land he loved solid and strong and secure. You can do a job for defense . . . by buying United States Defense* Bonds, *now!* For your bonds give your country greater strength. And a strong America is your best hope for peace and freedom—just as it was his.

Defense is your job, too. For the sake of *every* man in service, and for *yours*, start buying more United States Defense Bonds now.

Remember that when you're buying bonds for national defense, you're also building a personal reserve of cash savings. Remember, too, that if you don't save *regularly*, you generally don't save at all. Money you take

home usually is money spent. So sign up today in the Payroll Savings Plan where you work, or the Bond-A-Month Plan where you bank. For your country's security, and your own, buy U. S. Defense Bonds now!

****U.S. Savings Bonds are Defense Bonds - Buy them regularly!***

The U. S. Government does not pay for this advertisement. It is donated by this publication in cooperation with the Advertising Council and the Magazine Publishers of America as a public service.



Simplex
T.M. REG. U. S. PAT. OFF.

**CHOSEN
AGAIN**

McCUTCHEN

and

RODGERS

SELECT SIMPLEX X-L

FOR THEIR

MIDWEST CIRCUIT!



Theater circuits must guarantee their patrons consistently fine motion picture entertainment in order to succeed. For this reason their only other type theory, depends on the steady return of a satisfied audience. These circuits, therefore, must have only the finest in motion picture equipment. That is why the McCutchen & Rodgers Circuit have chosen Simplex X-L—the finest in motion picture projection!

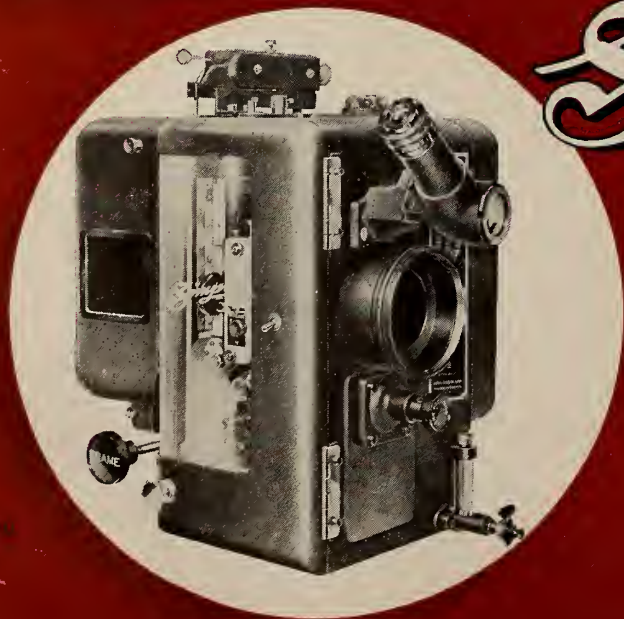

Simplex

X • L

**PROJECTION AND
SOUND SYSTEMS**

MANUFACTURED BY INTERNATIONAL PROJECTOR CORPORATION

DISTRIBUTED BY NATIONAL THEATRE SUPPLY

B 32988

PROJECTIONIST

**I
N
T
E
R
N
A
T
I
O
N
A
L**

LIBRARY OF CONGRESS
SERIALS ACQUISITION
DEC 3 - 1951
~~COPY~~



NOVEMBER

1951

VOLUME 26



NUMBER 11

30c A COPY



\$2.50 A YEAR

ALONGSIDE THESE LAMPS STAND THE WORLD'S FINEST PROJECTIONISTS

Peerless

1-KW TO 70 AMPS

MAGNARC
TRADE MARK REG

"HY-AX" ARC MAGNET

"HY-LUMEN" REFLECTOR

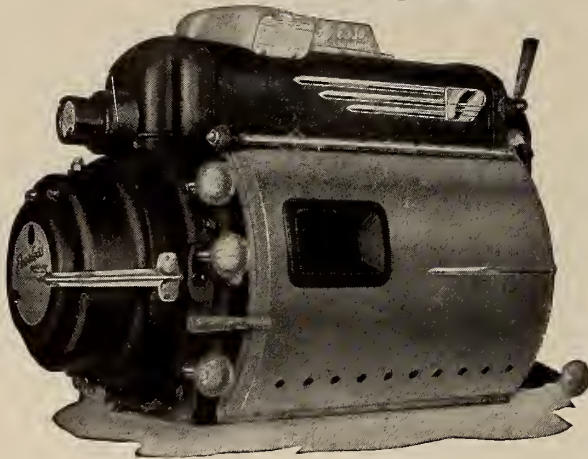

More light at 40 to 70 amperes than ever thought possible. . . . Equals and excels any reflector lamp to 85 amperes, whether they be unapproved water-cooled or resurrected "Hi-Lows". . . . Highest ratio of honest screen lumens per arc watt. . . . At 70 amperes, using an accurated Glass Hy-Lumen Reflector*, with a projector having an efficient revolving shutter, it develops the maximum screen brilliance that can be used without a heat filter at no risk of film damage. . . . Operating costs under these conditions are far below that of 85-ampere lamps.

Magnarc Lamps assure 80% side-to-center (SMPE Standard) screen light distribution, not a deceptive 60% or "Hot Center". . . . They are all Und. Lab., Inc. listed. . . . They are not insurance hazards. . . . They are and have been for years "The First Choice" of large and small theatres, drive-ins, and the motion picture industry.

* Similar results are not guaranteed if all-metal reflectors are used.

"FIRST WITH THE FINEST"

130-180 AMPERES

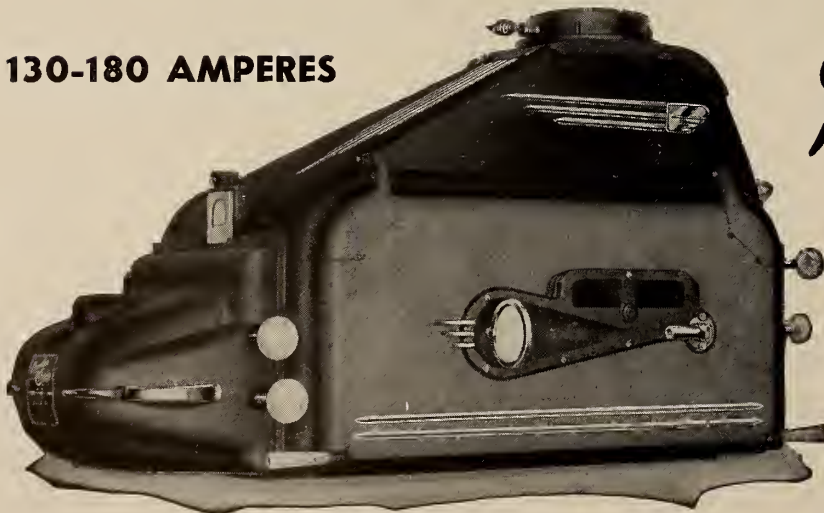

Peerless
HY-CANDESCENT
TRADE MARK REG

NEW MAGNETIC STABILIZER

This modern lamp produces all the light there is. . . . It is the standard equipment of the nation's largest and finest theatres. . . . Used by 90% of the largest Drive-In Theatres.

It is the "Omega" for maximum screen brilliance. . . . Nothing can even approach it in white light volume when used with projectors that have efficient revolving shutters.

Assures satisfying projection for Drive-Ins regardless of the size of the picture, length of throw, and under all weather conditions. . . . They are Und. Lab., Inc. listed and, therefore, not insurance hazards. . . . Heat filter assures no risk of film-heat damage at maximum arc amperage and maximum screen lumens.

"WHY EXPERIMENT?"



J.E. McAULEY MFG. CO.

552-554 WEST ADAMS STREET
CHICAGO 6, ILLINOIS

INTERNATIONAL PROJECTIONIST

With Which Is Combined PROJECTION ENGINEERING



HENRY B. SELLWOOD, *Editor*

Volume 26

NOVEMBER 1951

Number 11

Index and Monthly Chat	3	The Allied Arts & Sciences	15
The Trail of the Elusive Screen Lumen	5	III. Photographic Optics BAUSCH & LOMB OPTICAL CO.	
CHARLES HAHN		In the Spotlight	16
Technical Activities of the Mo- tion Picture Research Council	10	HARRY SHERMAN	
W. F. KELLEY AND W. V. WOLFE		Theater Screen Brightness Sur- vey	18
Projectionist's Role as a Show- man	13	A REPORT BY THE SMPTE SCREEN BRIGHTNESS COMMITTEE	
ROBERT A. MITCHELL		GPL-NTS Theater Tv Attracts 400 to 25-30 Club Meeting	22
'Business Week' Magazine As- says Movies' Economic Status	14	News Notes	
		Technical Hints	
		Miscellaneous Items	

Published Monthly by

INTERNATIONAL PROJECTIONIST PUBLISHING CO., INC.

19 West 44 Street, New York 18, N. Y.

Telephone: MURRAY Hill 2-2948

R. A. ENTRACHT, Publisher

SUBSCRIPTION REPRESENTATIVES

AUSTRALIA: McGills, 183 Elizabeth St., Melbourne

NEW ZEALAND: Te Aro Book Depot, Ltd., 64 Courtenay Place, Wellington

ENGLAND and DOMINIONS: Wm. Dawson & Sons, Ltd., Macklin St., London, W. C. 2

YEARLY SUBSCRIPTION: United States and possessions, \$2.50 (two years, \$4); Canada and foreign countries, \$3; single copies, 30 cents. Changes of address should be submitted two weeks in advance of publication date to insure receipt of current issue. Entered as second class matter February 8, 1932, at the Post Office at New York, N. Y., under the act of March 3, 1879. Entire contents copyrighted 1951 by International Projectionist Publishing Co., Inc. INTERNATIONAL PROJECTIONIST is not responsible for personal opinions appearing in signed articles in its columns.



MONTHLY CHAT

THE constant striving on the part of arclamp manufacturers and projectionists for a higher level of screen brightness is pointed up, although from different avenues of approach, by two articles appearing in this issue: "The Trail of the Elusive Screen Lumen," by Charles Hahn of J. E. McAuley Co., and the report of the SMPTE Screen Brightness Committee.

Mr. Hahn is most emphatic but not dogmatic in his treatise on light, and therefore heat, levels in motion picture projection. Asserting that careful and extensive tests revealed that 16,000 lumens is the most that the film will take without serious damage, Mr. Hahn decries the so-what attitude of those who keep upping the light level without utilizing some means for taking the heat-sting out of the light. His preference is for the heat-absorbing glass filter system, which he holds to be the most efficient means for doing the job with a minimum light loss.

High-velocity air streams, interference coating filters, and water-cooled mechanism setups don't catch the Hahn fancy, and he's quite positive in saying so—and why. Other manufacturers and projectionists hold to different views, and it would be a pity if the Hahn effort did not provoke a forthright expression of those views.

The SMPTE report reveals that a survey of 125 indoor theaters and 18 West Coast studio review rooms showed that about one-half of the indoor theater and two-thirds of the review room projectors produced screen brightness within the American Standard range. The remainder ranged from extremely low to excessively high. *Distribution* of light over theater screens likewise ranged from very uniform to extremely non-uniform. Screen reflectivity varied from values typical of screens in good condition all the way down to a level of 50% deterioration.

Now, it seems to us that there is something radically wrong with an industry which, recently observing its 50th anniversary, permits the existence of such conditions. It would be had enough in any industry, but in show business where entertainment is merchandised it is unthinkable. Sure, there are many links in the projection chain, and only a single defect along the way can ruin the overall effect produced. Yet uniform distribution of screen light is not too tough a problem to lick; and a screen deterioration of 50% is disgraceful.

The great majority of exhibitors either don't know or don't care about such problems: they're strictly lobby boys. But the great majority of projectionists *do* know and *should* care about such matters. Much could be done by way of corrective action right in the projection room, and we suggest that projectionists start doing those few simple chores right now.

WHICH

**OF THESE SPOTLIGHTS
IS RIGHT FOR
YOUR
LIGHTING JOB -**

RIGHT for

- LARGE THEATRES**
- ARENAS**
- ICE SHOWS**
- AUDITORIUMS**



**THE STRONG TROUPEUR
HIGH INTENSITY
ARC SPOTLIGHT**

Projects a sharp, snow-white spot without the use of heavy rotating equipment. Quiet... flickerless... portable. Draws only 10 amperes from any 110-volt A.C. convenience outlet. Adjustable, self-regulating transformer in base. Silvered glass reflector. Two-element variable focal length lens system. Automatic arc control. A trim of carbons burns one hour and 20 minutes at 21 volts and 45 amperes. Easily disassembled for shipping.

RIGHT for

- SMALL THEATRES**
- HOTELS**
- NIGHT CLUBS**
- SCHOOLS & COLLEGES**



**THE STRONG TROUPERETTE
INCANDESCENT
SPOTLIGHT**

Projects 6½ times brighter head spots. Sharp edge from head spot to flood. As contrasted to conventional incandescent spotlights, with which the spot size is varied solely by iris, to result in substantial light loss, the Trouperette utilizes all the light through most of the spot sizes. Variable focal length objective lens system, 5¼" silvered glass reflector, Fresnel lens. Plugs into any 110-volt convenience outlet.

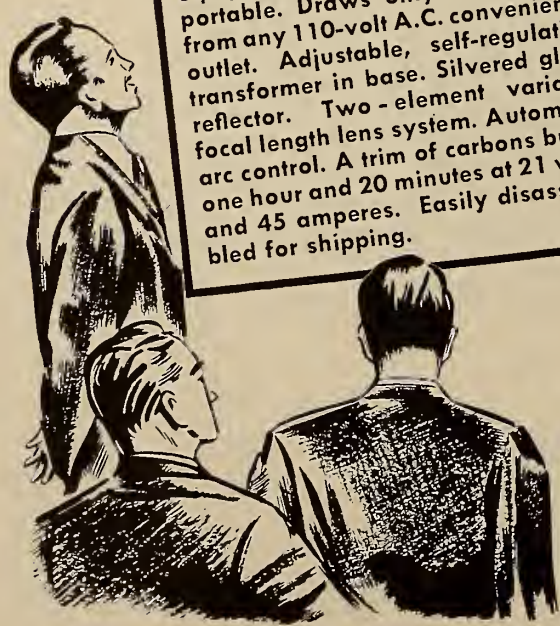

THE STRONG ELECTRIC CORPORATION
'The World's Largest Manufacturer of Projection Arc Lamps'
 14 City Park Avenue Toledo 2, Ohio
 Please send free literature on the Strong Trouperette Incandescent Spotlight; Strong Trouper Arc Spotlight.

Name _____
 Company _____
 Street _____
 City & State _____



The Trail of the Elusive Screen Lumen

By CHARLES HAHN

J. E. McAuley Manufacturing Co.*

Here is a forthright presentation of the views of a leading arclamp manufacturer on the highly controversial topic of the relationship of total screen illumination to aperture light-heat, plus an evaluation of heat radiation and heat absorption methods to prevent film damage. Provocative this article surely is in the light of the views held and often expressed in other responsible quarters of the projection field.

HIGH aperture heat first became a serious problem back in 1929-30 as the first reflector arc lamps using the 9-mm high-intensity type, rotating positive carbons, inadvertently named "Hi-Lo," became more generally used for theater projection. At that time projector manufacturers made their first contribution toward solving the problem by changing the location of the outside revolving shutter from its usual, in front of the projection lens position (front shutter), to its present position between the projector aperture and the light source (rear shutter).

The term "light heat" used herein refers to the thermal rise which follows the stoppage of all, or a portion of, the radiant energy produced by any type of 35-mm projection arc lamp. This thermal rise (heat) increases proportionately with the amount of light extracted from the total light beam as it traverses the axis of the projector optical system.

Three Methods in Use

Today, when more than 16,000 total lumens are to be used on a screen, there are three methods offered as means to

afford light-heat protection to the film; yet only one method basically assures positive and consistent results: heat-absorbing glass filters which are inserted in the light beam between the rear shutter of the projector and the light source.

The absorption system is completely protective because its degree of heat filtering is selective and it actually extracts that part of the total heat from the light beam, the cause of film damage, and this before it reaches the projector and film. In consequence, it results in a lower operating temperature of the projector mechanism, and also a lower degree of heat absorption by the projection lens.

The second method is by heat-ray (infrared) deflection, through the use of interference coatings applied to one side of a single piece of heat-resisting glass or fused quartz that is inserted in the light beam, similar to our heat-absorbing glass filters.

Interference Coating Characteristics

Our experience with this type filter has been fairly successful, even in its present state of development, but the deflective coatings have not been too stable and they will deteriorate, gradually disintegrating and breaking down, probably

from the higher heat in the center area of the glass, or fused quartz disc, to which they are applied.

Such deterioration of the reflective coatings was found to be greatly accelerated when used with light beams of intensities that produced more than 20,000 total screen lumens, and that such charring or disintegration of the coatings as it progresses become responsible for visible screen light losses of upward to 35%.

Also of importance is the fact that they have not proven to be as efficient as our heat-absorbing glass system because, being of one piece, the total visible light beam from the arc must pass through them when they are in their operating position. Hence, their percentage-wise loss of visible light is a constant, because they do not provide the selective degree feature of heat transmission found in the heat-absorbing glass system.

Because our tests have convinced us this type of filter is not a consistent protective medium, and because the effectiveness of its reflective coatings, due to their inherent fragility, can be seriously impaired by the ever-present hazards of operation, we feel we should eliminate it from immediate consideration, pending further development.

High-Velocity Air Streams

The third method is by heat radiation through the use of high-velocity air streams from jets which are directed against the front and back, or edgewise across, or directly on one or both sides of the film at the aperture opening in the projector mechanism.

First, such high velocity air-cooling systems have an exceedingly high initial cost. They also entail the complication and high cost of installing suitable pip-

* Chicago, Ill. Makers of Peerless projection arclamps.

ing systems, and possibly equalizing valves, to control the jets of air to prevent bending or the bellying of the film at the aperture, which will follow if an unequal air pressure develops on one or the other side of the film.

Power, Filtering Requirements

Another requirement of this system is that to maintain an adequate air supply and pressure, the air source would have to be powered by at least a 2-hp. motor (approximately 1600 watts). It would also have to operate continuously, hence there is a sizeable current cost to be considered. Such a system should also include a fairly large expansion tank, so that the air may cool before it is blown on the film. The air tank should also be provided with a safety valve, should an air compressor be used, and to reduce an excessive accumulation of airborne dirt and airborne moisture in and around the projector mechanism and on the projection lens (which would affect focus), a better than ordinary air filter and air drier must be used.

In the event that a motor-driven rotary air pump is used for the air supply, instead of an air compressor, adequate filtration of airborne dust and moisture becomes a more difficult problem, because such air sources cannot build up the necessary pressure to force the air through really efficient air-filtering mediums.

Small-Area Metal Contact

The ever-present collection of dirt and oily smudge that is seen around any air vent or exhaust fan, ventilating and air conditioning-system outlet is evidence that similar accumulations of dirt and

damaging grit is bound to occur in the projector mechanism.

We all know that as film passes through the projector—sprockets, guide rollers, film tracks, tension shoes, etc.—it only comes in contact with the metal parts for a width approximately equal to the width of the sprocket hole area on each edge. Also, that this center clearance is provided for each face of the film to prevent scratches and damage to the emulsion and plain side of the photo frame area.

In our original work with air-cooling systems, we found that due to this center clearance area for the film, when only slightly warped film was used, a high-velocity air stream of sufficient volume to be only slightly effective in radiating the light heat resulted in an accelerated rate of in-and-out-of focus fluttering of the film at the aperture—much more than is normally experienced when no air stream was used; and that such fluttering tendency was again markedly increased when the high-velocity air stream was directed across both faces of the film from an edgewise position.

Studio Work No Criterion

From these facts, therefore, we believe it is erroneous to jump at the conclusion that just because aperture "high-velocity air cooling" contributed to, and in a great measure made practical, the present method of background projection in motion picture studios, it will likewise solve the aperture heat problem for theater projection. The projection principles and problems involved are totally different and unrelated.

From the foregoing it can be seen that this system's high initial cost, high in-

stallation cost, and the expense of possible mechanical failure of motors, compressors, blowers, air pump, replacement of filters, and maintenance, all contribute to an exceedingly high operational cost. Even if it were possible to substantiate its sponsors' claim of film protection and screen illumination gain (which to date have not been proven to be anything else than theoretical) the cost of obtaining each such additional theoretical screen lumen would reach an astronomical figure.

Water-Cooling System

Relative to water-cooled, 35-mm projector film traps, gates, and aperture spot heat shields: sales conversation and, we regretfully add, manufacturers' fallacious advertising have created an erroneous impression that no system of light-heat filtering is required to protect the film against heat damage on such projectors. Our work with projectors so equipped has proven that nothing could be farther from the truth.

The use of water-cooled projector film traps and gates does not in any way reduce the initial temperature impact of the light-heat striking the projector or film. This system can only carry off the higher temperatures that are absorbed by projector mechanism parts. Hence, it can be understood that its effectiveness to even slightly affect the temperature impact of the light on the film itself exposure is completely nil.

Installation, Operating Data

Mechanism water-cooling systems, like air-cooling, also present quite sizeable installation complications, because a water-circulating means must be pro-

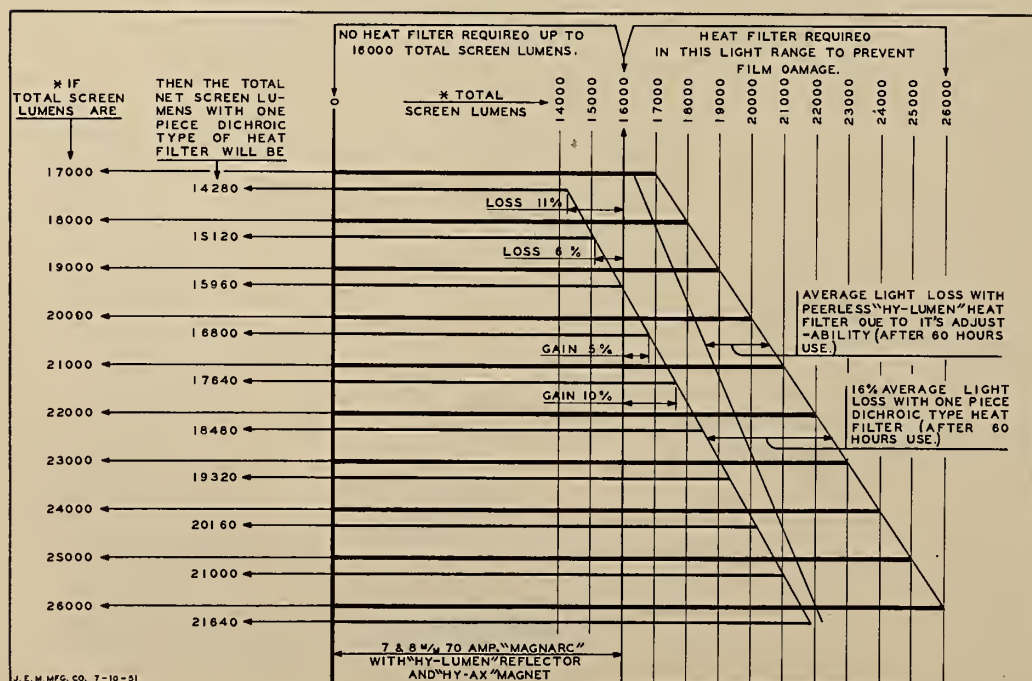

HEAT FILTER LIGHT LOSSES

*(See Cols. 1 & 2)

Obtained using an F:2.0 coated projection lens—without projector shutter, or porthole glass, or #G-292—E Pyrex air deflector, and with no allowance for metal reflector losses or for water-contact cooling devices when used with carbons not designed for such operation.



TO THE STUDIOS...

IT MEANS

**BETTER
MOVIES!**



TO THE THEATRE OWNER...

IT MEANS

**BIGGER
BOX OFFICE!**

It's the **NATIONAL**
TRADE-MARK
CARBON ARC'S

BIG 5



When you order studio or projector
carbons—order "National"!

The "National" carbon arc is an indispensable tool—both to the studios which make movies and to the theatre owner who exhibits them. Why? The "National" carbon arc's BIG FIVE:

- SMALL SOURCE SIZE
- HIGH BRIGHTNESS
- GREAT POWER FROM ONE UNIT
- WHITE LIGHT
- MINIMUM HEAT PER FOOT CANDLE

*The term "National" is a registered trade-mark of
Union Carbide and Carbon Corporation*

NATIONAL CARBON COMPANY

A Division of Union Carbide and Carbon Corporation
30 East 42nd Street, New York 17, N.Y.

District Sales Offices: Atlanta, Chicago, Dallas,
Kansas City, New York, Pittsburgh, San Francisco

In Canada: National Carbon Limited, Montreal, Toronto, Winnipeg

For the studio, small source size insures sharp, dramatic shadows, better simulates one-source lighting, creates a perfect "follow-spot". High brightness penetrates deep sets, gives high light levels without excessive heat.

White light matches outdoor shooting conditions, lends itself perfectly to color movies.

For the theatre owner, the carbon arc provides the "brightest spot in the world"—gives him the dazzling power he needs to get diamond-sharp pictures, vivid color and keeps his box office booming. The "National" carbon arc is tops.

**YOU CAN'T SKIMP ON STUDIO LIGHTING
WITHOUT RISKING BOX OFFICE!**

vided. In cold weather, or in cases where the normal temperature of a water supply is rather low, a moist condensation can accumulate on the cooled projector parts. Humid weather will also promote the formation of a condensation on the cooled parts.

Finally, while the water-cooling of projector parts may have a beneficial mechanical effect on the projector mechanism, the actual or dollar value of such mechanical benefits would be so infinitesimal and hard to recognize as to not justify its first cost, installation expense and maintenance.

Heat-Absorbing Glass

Comparing now the use of heat-absorbing glass to protect the film from light-heat damage. First, it is extremely simple and definitely effective because it actually extracts the damaging light heat from the total light beam before it reaches the projector mechanism and film.

A filter glass unit consists of a metal frame with provision to hold a total of six strips of filter glass, each $\frac{1}{2}$ x 4 inches and only $1\frac{1}{2}$ mm in thickness. The strips are removable so that only as many need be interposed in the light beam as is required to prevent film damage at the particular current drawn at the arc.

Over-all Light Loss

With the entire six strips in use, the average total visible screen illumination loss is 14% or less. This can be reduced to approximately 7% or 8% when only three or four strips are needed to prevent film damage. Many installations using 180 amperes at the arc are so operating. In most cases, the gain in illumination that will follow the removal of porthole glass will more than make up for the visible light loss of the filter glasses.

By comparison, it is perfectly obvious that for theater projection the absorption system is extremely simple and definitely effective. It entails no high installation cost, complications, or high operating cost. An absorption heat-filter requires only a 1/50-h.p. motor to operate the blower which cools the filter glasses, and the motor need run, if desired, only when the projector is in operation.

20% Loss Figure Arbitrary

Right at this point we believe a correction is in order of the erroneous general impression that the use of glass heat-absorbing filters will arbitrarily result in a visible light loss of 20%. This round percentage figure undoubtedly originated, and would more or less correctly apply, to the first internally-colored heat filter glass that became commercially available. We refer to Nos. 395 and 3966 Aklo heat-absorbing glass of 2 mm thickness.

Also, it must be clearly understood that a laboratory-developed transmission

curve will materially vary as a thinner or thicker piece of filter glass is tested. Hence, a round percentagewise figure accepted as the measure of visible light loss that will follow the use of any or all types of heat-filter glass can be misleading.

To speak in round percentage ratios: with No. 3966 Aklo, referred to previously, a 2-mm thickness could be considered as having an optimum heat-absorption ratio of 70% and an optimum visible-ray transmission ratio of 80%. These percentages, however, for reasons stated previously, are subject to change as thinner glass is used. We always used this glass $1\frac{1}{2}$ mm in thickness, thus the optimum visible transmission percentage was more correctly near 83 or 84% when the complete light beam transpierced the six filter glass strips.

New Glass Ups Light Level

Still further favoring the advantages afforded by the heat-absorbing glass system is the newly developed Phosphate-type glass which we have used exclusively for the last four years. Laboratory-developed transmission curves of 2 mm thickness glass show that this type of glass passes an even higher optimum percentage of the visible light rays, about 84%; but because we use this new glass in only $1\frac{1}{2}$ mm thickness strips, this 84% optimum transmission percentage is increased to 86-87%.

It is pertinent to mention here that regardless of the type of high-intensity lamp used, or how large the reflector might be, or the diameter of the carbon combination, or the number of amperes drawn at the arc, it is authoritatively conceded that with the present range of photographic density, if no light heat filter or film-cooling means are used, the absolute top level of screen illumination

that it is safe to use to definitely avert film damage from light-heat is 16,000 total screen lumens.

This screen lumen figure is to be measured when using either a silvered glass reflector or a condenser lens system, without film in the projector, without revolving shutter light losses, without port glass light losses, but with an accurately aligned optical system.

Hence, the unalterable fact to remember is that it is primarily and *only the film itself* that is the limiting factor which determines the maximum screen light when no definite supplementary means is employed to prevent film damage from light-heat.

Metal Reflector Data

Referring particularly to reflector-type arc lamps, predicated on the high level of the reflectivity of silvered glass reflectors, our illumination limit of 16,000 total visible screen lumens is well within the capacity of 70-ampere arcs using the 7 x 8-mm copper-coated carbon trim. However, if a metal reflector having a "rhodium" reflective surface is used, this 16,000 total visible screen lumens limit is materially reduced, because rhodium-surfaced metal reflectors reflect approximately 20% less of the visible light rays, in wave-lengths of from 4,000 to 7,500 Angstrom units, and at their lower level of visible ray reflectivity they transmit approximately 20% more of the visible heat rays (infrared) in wave-lengths of from 7,500 to 40,000 Angstrom units.

Keeping this inherent inefficiency characteristic in mind, let's assume we were to increase the current of a 70-ampere arc having a metal reflector (by changing to larger diameter carbons so we could accommodate the current increase necessary

(Continued on page 29)

OFFICERS AND DIRECTORS OF TESMA WHO WILL SERVE FOR THE COMING YEAR



Seated, left to right: Oscar Neu (Neumade Products), retiring president and honorary board member; Roy Boomer, sec.-treas.; J. Robert Hoff (Ballantyne), president; Lee Jones (Neumade), vice-pres.; and W. A. Gedris (Ideal Seating), board member. Board members shown standing, left to right: Bill DeVry (DeVry Corp.); Fred Matthews (Motiograph); Jack O'Brien (RCA); H. B. Engel, W. C. Stober, Ben Adler (Adler Signs); Jack Nolan (National Carbon); Clarence Ashcraft (Ashcraft Mfg. Co.); Ed Wagner (Wagner Signs); Larry Davee (Century Projector Corp.).

The Eastman

16mm. Projector,

MODEL 25



HERE is a precision-designed, craftsman-built projection instrument which delivers a screen image and sound reproduction from 16mm. film that compares favorably with the performance of the most advanced 35mm. equipment. You can be certain of theater-quality projection of your 16mm. sound films when they are shown with an Eastman 16mm. Projector, Model 25. The standard model may be fitted with tungsten or carbon arc lamp.

For more detailed information, including mechanical and installation specifications, fill out the coupon below now, and mail it today. Your free copy of the booklet, "Theater Quality 16mm. Projection," will be in the return mail, postpaid.

Extra Assurance for Trouble-Free Performance

Every purchase of an Eastman 16mm. Projector, Model 25, in the U.S.A. includes installation supervision and thirty-day service from date of installation by the Altec Service Corporation.

Motion Picture Film Department
Eastman Kodak Company
Rochester 4, N. Y.

East Coast Division
342 Madison Avenue
New York 17, New York

Midwest Division
137 North Wabash Avenue
Chicago 2, Illinois

West Coast Division
6706 Santa Monica Blvd.
Hollywood 38, California

Eastman Kodak Company

343 STATE STREET, ROCHESTER 4, N. Y., DEPT. 8

Please send copy of "Theater Quality 16mm.
Projection" at earliest convenience.

NAME _____

COMPANY (OR THEATER) _____

STREET _____

CITY _____ ZONE _____ STATE _____

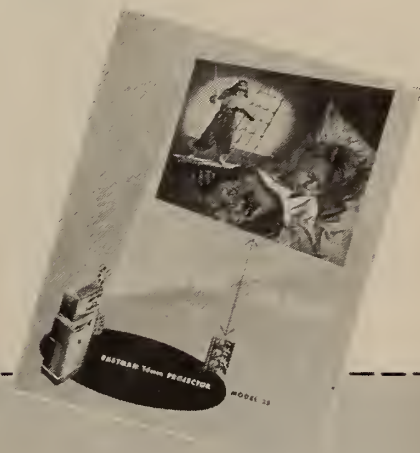

Technical Activities of the Motion Picture Research Council†

By W. F. KELLEY and W. V. WOLFE

A résumé of some of the more important activities of the Council and its connection with new products, inventions, television, stereoscopy, standards and test films.



FIG. 1. Mercury-cadmium lamp under test.

BY 1947 it was freely recognized that insofar as methods, processes and equipment are concerned, there was no need for competition among the producers of motion pictures. Accordingly, it was practical to carry on the development of such equipment, processes and methods in a common industry-sponsored technical organization.

With this end in view, the Motion Picture Research Council was separated from the Academy of Motion Picture Arts and Sciences and incorporated under the laws of the State of California. Funds and facilities were made available, and the business of organizing a staff of qualified technical people and securing for them the necessary equipment and quarters was undertaken.

The Research Council is interested in any and all technical problems in the production or exhibition of motion pictures. In general, the activities can be divided into three groups: service functions, short-range development and design problems, and long-range advanced development problems. The staff includes two physicists, three chemists, two mechanical engineers, two electrical engineers and supporting personnel.

Although the Research Council now has its own technical staff and facilities, it needs the guidance of the many expert technicians of the industry. This is provided through a group of 14 basic com-

mittees covering every phase of the technical activity of the industry.

The Research Council is a small organization covering a broad and diverse field. Its only possible chance of working successfully under such conditions lies in the cooperation which it seeks and receives from other industries throughout the country.

Set Lighting Developments

Since it is the purpose of the Research Council to serve the motion picture industry, it is not concerned with glory in solving problems, but only with the solution. If any other organization has a satisfactory answer, then the aims of the Research Council have been completely satisfied when that answer is made available to the industry.

Projects of many types and varieties

are undertaken by the Research Council, either on its own or in cooperation with other companies. For example, set lighting is one of our most important projects. We will be concerned with it as long as there is a motion picture industry. Presently, we are carrying on work on set lighting in all three branches of our activity, that is to say, service function, short-range design and development and long-range advanced development.

Figure 1 shows a mercury-cadmium lamp under test. The "Man from Mars" helmet is, of course, a standard welder's helmet, equipped with special glass to permit safe viewing of the intense light produced by this mercury-cadmium lamp. Since this lamp is contained in a quartz bulb, it produces high intensities in the ultraviolet, so that artificial sunburn is difficult to avoid. In studying lamps of this type, it is necessary to know as much as possible about their color quality and variation, if any, in color quality as a function of age and various operating conditions. Such studies are made with a spectroradiometer and filtered light meters, and also photographically.

Studies of the zirconium arc, both enclosed and open-air varieties, have been carried on, although for set lighting purposes these arcs do not appear to have sufficient intensity or satisfactory color temperature.

Other New Light Sources

The xenon gas arc has long been known and studied and is perhaps most familiar to us in the flashtubes so successfully used for stroboscopic high-speed photography. Not so well known is the fact that in Germany and England development work has been in progress on a high-intensity xenon arc of capacities ranging up to 1000 w.

In Germany an air-cooled lamp of this type has recently emerged from the research laboratories. It is being watched with care and samples will be obtained by the Research Council as soon as possible. This lamp has better color characteristics, having almost a continuum

FIGURE 2
Typical brightness fall-off curves—
goniophotometer measurements.

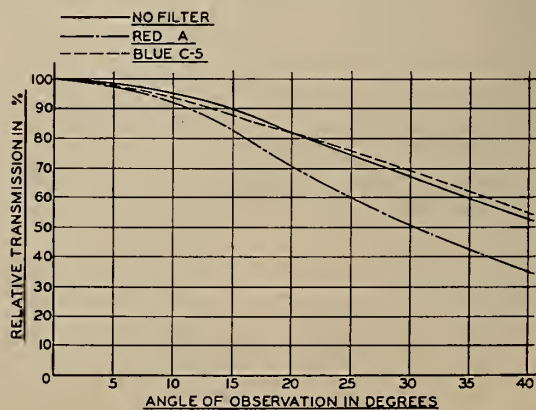

† J. Soc. Mot. Pict. & Tv Eng., Feb. 1951.

The **No. 1**

LAMP

for projecting the most
light to any screen—
regardless of how large
—and the No. 1 lamp
for saving you money.

At 90 amperes it pro-
jects 21,000 lumens at
far less cost than any
other types of big lamps.

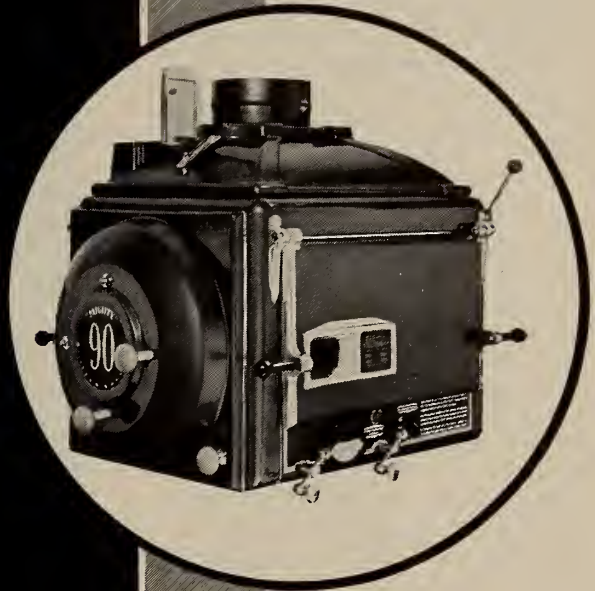

THE STRONG

MIGHTY "90"

75 TO 130 AMPERE REFLECTOR ARC LAMP

Write today for free literature

The Strong Electric Corporation
31 City Park Avenue • Toledo 2, Ohio

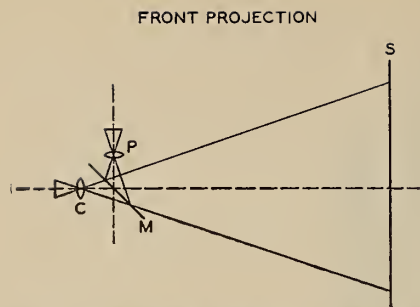

FIG. 3. Schematic drawing of a set-up for front projection.

throughout the entire spectrum and a color temperature of the order of 6000 K degrees (Kelvin), coupled with instant starting. If it can be made commercially available, it can occupy a position of real importance in set lighting for motion pictures.

Composite photography is a matter of vital importance to the motion picture industry. It permits making many shots which would otherwise be impossible, and making many more shots which would be impractical from an economic standpoint if made by any other process. There are two general types of composite photography, commonly called transparency process photography and matte photography. Both of these forms of composite photography are under study.

A goniophotometer built for our special application has been used to measure the color characteristics of transparency screens. The results of one such test are shown in Fig. 2. These tests are verified, wherever that is important, by actual photographic measurements, since it must be constantly borne in mind that the characteristics of the photographic emulsion are an inseparable part of the problem.



FIG. 4. Front projection with foreground lighting.

The difference in fall-off characteristics of this particular screen sample at the different ends of the spectrum is of obvious importance for color photography, but is also important for black-and-white photography since it must effect the resultant definition in many cases.

The method of making a composite photograph which consists of photographing foreground objects while simultaneously rephotographing from a screen the desired background, can, of course, be employed with a reflection type of screen and front projection as well as with a translucent screen and rear projection.

For example, in Fig. 3, is a simplified



FIG. 5. Front projection without foreground lighting.

setup showing a camera, C, a projector, P, and a diaphone mirror, M. The picture from the projector is reflected by

the mirror to the screen, S, and rephotographed by the camera along with the foreground object.

Figure 4 is an example of this type of photography, for the young lady is seated in front of what appears to be an open window through which the city may be seen. Fig. 5 shows what happens if the foreground lights are turned off so that the camera sees only the silhouette and the rephotographed view of the city. This last slide is included primarily to show that the intensity of light required from the projector is insufficient to register on the foreground object even though it is sufficient to provide a brilliant picture of the background. The differences in

reflection characteristics are, of course, responsible for the operation of such an arrangement.

There are many problems in connection with the successful use of front projection. The idea is not new, but its application and limitations have never before been properly defined, which is the primary object of the investigation in that field.

Efficient Screen Types

The industry has long been intrigued by the considerable increase in efficiency which can be obtained with a directional translucent screen as contrasted to a nondirectional screen, but in most cases the requirement for a mobile camera, coupled with manufacturing problems, has prevented the use of such screens. General awareness of the difficulties and the problems involved in a directional screen and acquaintance with much of the earlier work that has been done on this subject have also stimulated the investigation in that direction.

There presently seems some promise
(Continued on page 27)

Projectionist's Role as a Showman

By ROBERT A. MITCHELL

THE motion picture theater performs a *unique* function. It adorns its product with a delicious icing of glamour. By *glamour* the drama-charged atmosphere of the theater is meant. It is an emotional thing. This atmosphere is created, not alone by the screen attractions, but also by the surroundings and the technique of presenting entertainment. In a word, this atmospheric effect is due largely to *showmanship*.

The Chief Showman of the theater is the projectionist. It is he who runs the show and thus delivers the entertainment which the patron pays to see. The quality of the picture and sound reproduction is his responsibility, and the *manner* of presentation determines in the long run whether the paying patron attends or stays away.

Stereopticon Projection

Stereopticon slides, especially the typewritten "Radio-Mat" variety, are something of an eyesore in a modern motion picture presentation. Sometimes, however, the management has good reasons for making special announcements on the screen. It is up to the projectionist, therefore, to make the slides as presentable as possible. There are three aspects to be considered.

First, handwritten or typewritten slides should be prepared as neatly as possible. Fingermarks on them should be avoided. The printed matter should be properly centered and contain no unnecessary wordage. A simple message is the most effective message.

Second, the efficiency of the stereo lantern must be kept up at all times. Condensing and objective lenses require frequent cleaning: because the slide is positioned close to the condenser, any dirt on the condensing lenses shows up more or less clearly on the screen.

Stereo vs. Movie Projection

The difference between a "motion picture" and a stereopticon optical system is illustrated by Fig. 1, wherein the movie optical system utilizes an incandescent lamp and condensing lenses—instead of arc and mirror—to make comparison easier. It will be noticed that in the movie projector the light-source is imaged in the plane of the "object" (film), while in the slide projector the light-source is imaged not on the "object" (slide) but on the *objective lens*.

In order to get maximum screen illumination from a stereopticon, therefore, the incandescent lamp-bulb must be moved forward or back to that position which causes the clearest possible image

of the lamp filament to be forced *on the objective lens*, thus giving uniform screen illumination.

The stereo projector should be set up beforehand so that the slide aperture image is properly centered on the screen. And the objective lens should be focused before the show and locked in position, if this is possible.

If the image of the clear stereo aperture happens to be slightly larger than the screen, well and good. Experimenting with cardboard aperture masks will enable determination of the proper size and shape of slide aperture needed to match exactly the size and rectangular shape of the motion picture screen image. A sheet-iron aperture plate can then be made and permanently fitted to the stereo. Typewritten slides may then be used without the undersize paper masks which are furnished with them.

The third aspect is the smooth transition from movies to slide and *vice versa*—a matter of operating technique and showmanship.

If the stereo lamp can be turned on and off by means of wall switches, one near each projector, a smooth change-over can easily be effected. Otherwise the projectionist is forced to exert considerable prowess as an acrobat to avoid a "dark screen" or a prolonged period of "double exposure." With the proper control facilities, the projectionist can use the title curtain and, when thought desirable, a few bars of appropriate music from the non-sync.

Color on the Stereo Image

Slides can sometimes be "pepped up" by coloring the stereo light by means of small sheets of suitably tinted cellophane

or spotlight gelatine stretched tightly in a color wheel or other holder placed before the objective lens. Pink, amber, yellow, green, blue, red, violet, *etc.*, can be interchanged frequently when slides are used at every show.

The tinting of motion picture prevue trailers in this manner has been all but abandoned, now that natural color trailers are common. The practice was formerly useful for "tying together" the two trailers of a double-feature bill. For example, prevues of a double-feature "horror show" could be projected through green or violet gelatine. Amber, yellow, or pink might be suitable for most other double-feature combinations.

As an alternative to "gelatinizing" the projector light, colored light—footlights, striplights, or a spotlight—can be used to illuminate the screen during black-and-white trailers. This gives the effect of "toned" film, rather than all-over tinting. BUT—guard against overdoing a technique which is pleasing when used sparingly and on appropriate occasions. Sound showmanship involves restraint as well as innovation.

Closely allied to this topic is the color-flooding of titles, a matter to be examined later.

Pre-Show Preparations

Preparation for a show is a routine matter. The projectors are thoroughly cleaned and oiled before the show; and adjustments are made in the equipment when such are necessary. The sound equipment is checked by making "click" tests of both the non-sync and the sound-on-film reproducers. The main line voltage, the voltage output of exciting-lamp rectifiers, and the plate current of amplifier power tubes are read from the meters with which certain makes of sound equipment are fitted. The arc-lamp generator (or rectifier) is checked for faults; and the lamps themselves are cleaned, lubricated and trimmed with carbons of sufficient length to run at least one reel of film.

The importance of keeping the lamp mirrors clean at all times cannot be overemphasized. The white dust which settles upon them is a metallic, or *basic*, oxide which reacts, when hot, with the *acid anhydride* of glass, thus etching, or "frosting," the glass in time. Then too, spots of soot (finely divided carbon) on the glass may cause the mirror to crack unexpectedly, a matter to be discussed later.

Keep a small pad of paper on your desk or on the rewind bench and use it

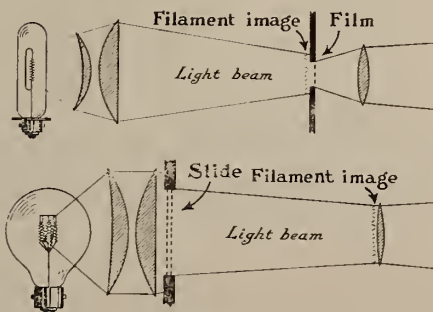

FIGURE 1

Comparison of the optical systems of motion picture (top) and stereopticon (lower) projectors. In the stereopticon, the image of the light-source is formed on the objective lens instead of on the transparent picture, as in the movie projector.

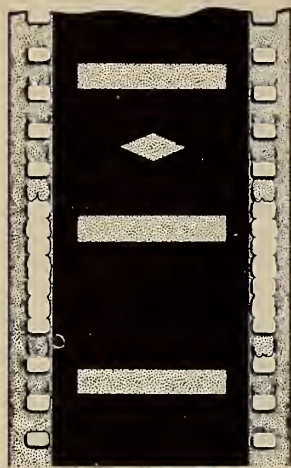

FIGURE 2
Torn-out perforations on film leader.

for jotting down all defects in the equipment or its performance noticed during actual projection. Many minor faults can be corrected during a show without interrupting the performance; but some, such as a bad optical line-up of the projectors or a noisy intermittent must wait until the show is over.

A long and complicated list of procedures could be formulated to provide a comprehensive "make-ready" routine; but most projectionists simply do not have the time to do *everything* every day. Certain duties must be doubled up on alternate days, and certain others are best placed on a once-a-week basis.

Every projectionist knows from experience the things that *must* be done, and also how long he can safely defer them. No projectionist need "knockdown" a projector mechanism once a week or even once a month just to establish good working condition. Once the equipment has been put in the best condition possible, a few minutes' inspection every day—and there is ample opportunity during the day for looking at all equipment—will provide sufficient warning of defects which may be developing.

Film Inspection Vital

There is one part of the pre-show preparation which, alas, is sometimes carried out too hastily. The film exchanges are morally and legally responsible for issuing prints in perfect running condition, but any projectionist who implicitly relies on exchanges will soon come to grief. There are three dangers in film breaks, namely:

1. Fire-risk of breaks in nitrate films.
2. Danger of damaging the projectors.
3. Danger of creating patron annoyance and dissatisfaction with theater, resulting in loss of business.

Not one splice, not a dozen splices, but *every splice* in *every reel* should be tested for strength and sprocket-hole registration. Splices occurring in "fades" should be checked for correct framing. It hurts the dramatic power of a picture

to have the screen image suddenly jump out of frame. Roughened and sheared edges of the film should be smoothed with scissors. "Sprocketed" film and otherwise mutilated footage should be cut out, rolled up, and tossed into the shipping case for return to the exchange.

Motor and changeover cues should be checked for visibility, scoring them by means of a professional cue-marker when they seem to be too faint. (But it is surprising how faint they can be on the film and still be easily seen on the screen!)

Any special cues, such as cues for curtains that take longer than 7 seconds to close, should be marked on the film, *not* by scoring or scratching the emulsion but with a china-marking pencil, and *wiped off before the print is shipped out*. The nuisance of having to add cues for the title curtain can be eliminated by speeding up the curtain so that it closes in 6 or 7 seconds from the time that the curtain-control button in the projection room is pressed. Nothing more complicated than changing the old curtain drive pulley to one of slightly greater diameter is needed in most cases.

Film Leader Deficiencies

Standard release print film leaders, especially those which contain several splices, should be inspected inch by inch. A film-break during a changeover is extremely irritating. Avoid this danger by

making sure that every splice in every leader is as strong as the film itself, and that no torn perforations are present. Also, successive splices in any film should not be closer together than 10 inches, else the perforations may be weakened by the teeth of the intermittent sprocket.

A clip from a leader having torn-out perforations is shown in Fig. 2. A similar defect consists of an extended crack running from perforation to perforation on both edges of the film. This defect is a hard one to see and is best detected by "cupping" the film during inspection of leaders; it is just as dangerous as perforations completely torn out.

'Running Down' the Film

Film damage of these types is caused by a sudden yank or pull on the film, causing sprocket teeth to rip right through the perforations. The projectionist can do much to prevent torn sprocket holes. Before switching on a projector, be sure that there is no slack in the film between upper reel and the upper feed sprocket, or between lower takeup sprocket in the soundhead and the takeup reel. Slack film at either of these points can cause damage to film perforations. The projectionist who has formed the good habit of running down a few frames of film after threading up need have no worries on this score.

(Continued on page 26)

"Business Week"* Magazine Assays the Movies' Economic Status

*Copyright 1951 by "Business Week"

MOVIE MAKERS: A COMEBACK IN 1951?

Earnings for Fiscal Years

	1939	1946	1947	1948	1949	1950
Columbia Pictures	\$2,000	\$3,450,000	\$3,707,000	\$565,000	\$1,008,000	\$1,981,000
Laew's, Inc.	9,842,000	18,692,000	11,626,000	5,310,000	6,745,000	7,854,000
Paramount Pictures Corp.	---	18,701,000*	10,735,000*	5,842,000*	3,261,000*	6,565,000
RKO Pictures Corp.	---	6,271,000*	D1,787,000	D5,596,000	D4,219,000	D5,832,000
RKO Theatres Corp.	---	6,073,000*	6,360,000*	3,974,000*	4,173,000*	1,196,000*
Republic Pictures	1,061,000	1,098,000	570,000	D350,000	487,000	761,000
20th Century	4,147,000	22,620,000	14,004,000	12,509,000	12,415,000	9,553,000
United Paramount Theaters	---	20,498,000*	17,505,000*	16,727,000*	17,575,000*	12,142,000*
Universal Pictures	2,253,000	9,196,000	6,745,000	D3,163,000	D1,126,000	1,356,000
Warner Brothers	1,741,000	19,425,000	22,095,000	11,837,000	10,467,000	10,272,000

*Pro forma. Paramount split on Dec. 31, 1949; RKO on Dec. 31, 1950.
D—deficit.

THIS YEAR'S SHOWING SO FAR

	1950	1951	
Columbia Pictures	\$1,981,000	\$1,498,000	Fiscal year ending June 30.
Laew's, Inc.	6,019,000	5,568,000	40 weeks ended Jun. 7, '51, Jun. 8, '50.
Paramount Pictures Corp.	2,826,000	2,832,000	Six months ended June 30.
RKO Pictures Corp.	NA	D735,000	Six months ended June 30.
RKO Theatres Corp.	NA	552,000	Six months ended June 30.
Republic Pictures	831,000	728,000	39 weeks ended July 28, '51, July 29, '50.
20th Century	3,158,000	1,071,000	Six months ending June 30.
United Paramount Theaters	6,885,000	5,125,000	Six months ending June 30.
Universal Pictures	979,000	1,127,000	39 weeks ended July 28, '51, July 29, '50.
Warner Brothers	7,316,000	5,809,000	Nine months to May 26, '51, May 27, '50.

The Allied Arts and Sciences

A vast field of artistic and scientific endeavor is directly contributory to the motion picture process and, therefore, to the practice of projection. The true craftsman should have a well-rounded understanding of these contributory factors, particularly in view of the imminent widespread utilization of television and, possibly, stereoscopic pictures and stereophonic sound. This department will provide basic information on the aforementioned arts and sciences, a wide variety of topics being a primary aim.

III. Photographic Optics

Bausch & Lomb Optical Company, Rochester, New York

OUR lenses must not only give us good images, they must pass light, and illuminate the negative. Further, this illumination must be known and controllable, so the exposure will be subject to our will.

It is fairly clear that the larger the opening in a lens the more light it will admit. Further, we were apprised earlier that the longer the focal length of the lens, the larger the image at a given object distance. Now, in the larger image the light sent out by the object points is spread over a larger area, yielding a dimmer image. There is, as can be demonstrated both mathematically and practically, a reciprocal relationship between the image area and the illumination at constant aperture, so that as the image grows larger (longer focal lengths) the less the illumination.

Illumination Determinants

Now if at the same time we were increasing the image size we were increasing the area of the lens opening, we would obviously be maintaining the illumination in the image, and could make our exposure at the same shutter time. Thus at a given object distance (and we shall take an object at infinity), the illumination in the focal plane of an objective is determined by two factors, the area of the lens and its focal length.

Mathematically, the most convenient expression for the speed of a lens is given by the ratio of the focal length of a lens to its diameter. This is the relative aperture and is the standard denomination of lens speed today. For instance, if we have a lens of 4 inches focal length and 2 inches diameter, its relative aperture will be 4 divided by 2, or F:2. If the diameter were 1 inch, the lens would be F:4.

A 2-inch diameter pipe will carry 4 times the water a 1-inch pipe will, that is, the area of the pipe varies as the square of the diameter. Just so will the speed or light gathering power of a lens vary as the square of its diameter. It is found that the illumination in the image

varies inversely as the square of the relative aperture, and for this reason the sequence of relative apertures is by common agreement in steps of the square root of 2. Each step means doubling the illumination.

Lens Field off the Axis

So far we have considered the illumination on the axis of the lens. Everything we have said holds good also in the field of the lens off the axis, but there some further effects enter to complicate the issue.

For one thing, the image-forming light strikes the film at an angle, which lowers the efficiency of the photographic effect, and even more important, at large angles to the axis the effective aperture of the lens is reduced by reason of the separation of the front and rear elements, and because the round diaphragm off axis elongates like a cat's eye (Fig. 24).

All these effects cooperate to produce what can be a marked diminution of illumination at the corners of the picture area. These effects are generally known as *vignetting* and are serious in the case of wide-angle lenses particularly. The effects are seldom seen in photographs with lenses of normal focal lengths, for the characteristics of sensitive film are such as to hide them.

The illumination from a point source of light varies inversely as the square of the distance. This is elementary, and lies at the root of illumination theory. But, we might ask, if that is so why is it unnecessary to compensate for distance when making an exposure? Why is it

FIG. 24. Vignetting.

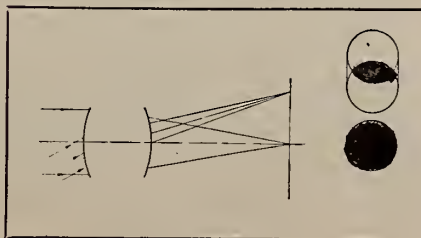

that the same exposure is required for a nearby tree as for a distant one?

Exposures Near and Far

This puzzling question has really a simple explanation, one illustrative of the fundamental principles we have been considering.

Consider two trees, situated, say, 20 feet and 40 feet from a camera. The nearer tree will send 1-over-20-squared, or 1/400 units of light, to the camera; while the farther tree will be emitting 1-over-40-squared, or 1/1600 units. Thus the nearer tree illuminates the negative plane with 4 times the light its farther counterpart does.

So far so good, but consider a bit farther. The size of the image must also vary with distance. In fact, the magnification is inversely proportional to the object distance. Then the height and breadth of the nearer tree will be just twice that of the farther one, since it is one-half the distance from the camera.

But the areas of the images of the two trees will be given by the products of their linear dimensions, and thus the nearer tree will cover 4 times the area of the farther tree. The nearer tree sends 4 times the light to the camera, distributing that light over 4 times the area, so that each element of film receives the same illumination from the one tree that it does from the other. That is to say, the exposure is the same for both trees.

This argument can be generalized to demonstrate that the exposure is independent of distance. Of course, in this argument we have neglected such things as aerial perspective, haze, etc.

Effective Relative Aperture

There is one important reservation to remember in the matter of relative aperture. We have seen that the most convenient measure of the speed of a lens is its relative aperture, or ratio of focal length to stop diameter. This gives a measure of the light-gathering power of a lens when focused on an infinitely distant object. What happens when focusing on very near objects?

We saw that the illumination is independent of distance because of the magnification. This magnification in turn is a function of the lens-to-film distance, such that the distance can be looked on as the equivalent of the focal length so that instead of the focal length being the primary quantity in determining the relative aperture, it is in reality the lens-to-film distance which is most important. Thus in making close-up shots, we cannot use the simple relative aperture as marked on the lens, but must make due allowance for the bellows extension.

For instance, if we are using our lens at one-to-one magnification—i.e., a bel-

(Continued on page 24)

IN THE SPOTLIGHT



By
**HARRY
SHERMAN**

FOR many years the motion picture industry has been notoriously lax in that it did not make use of its own medium, recognized world-wide as having a terrific impact, to promote its own interests. We were reminded of this recently when the progressive Bakery and Confectionery Workers' International Union stepped out and released "It's Up to You," a half-hour motion picture film which deals with accident hazards, safety methods and sanitary working conditions in plants where its members work.

Working from a meeting of a Union safety committee, the film "flashes back" as each member reports on a separate safety and sanitation subject, detailing the type of injury sustained and outlining preventive methods. The film goes beyond the individual worker's responsibility for *his own welfare* and deals with *management's* responsibility in providing safe and healthful workplaces, making the point that safety and health provisions are not "extras" but an integral part of plant and equipment.

If the people who make doughnuts and biscuits can utilize our medium to get fine results, so can we. Such a film would be a pushover for our craft on the basis of the various units working in concert. Our pet project, for example, of vastly improved sanitary conditions in projection rooms could be stressed in such a film, with the sharp contrast afforded between a first-class room and a mere hole-in-the-wall. And plenty of other angles could be covered.

Such a film could be circulated all over the country at Local and District meetings. Any thoughts on this topic?

• Bill Thompson, business representative for Pittsburgh Local 171, has fully recovered from his recent illness and is back on the job. Good Luck!

• William Tenney, president, and Douglas Calladine, past president, Vancouver Local 348, conferred with IA President Walsh in New York recently on the deadlock now existing in the long-drawn out negotiations with Famous Players Canadian Theaters. Local 348 is asking for a wage increase of 50c per hour, plus a

cost-of-living bonus of 1.1c per hour for each point rise in the cost of living. To date, Famous Players has countered with an offer of 35c per hour and no cost-of-living bonus.

The jurisdiction of the Vancouver Local takes in a vast territory covering an area of 400 miles wide by 600 miles long. It is not unusual for the Local to fly a man to fill an emergency job, a number of the theaters being located in sparsely-populated areas that have poor transportation facilities.

Although the members voted overwhelmingly to go on strike unless the Local's demands are met, our information is that the matter will be amicably settled very soon.

• The N. Y. State Ass'n of Motion Picture Projectionists held its annual conference in the meeting hall of Tobis Tavern, Auburn, N. Y., on Monday, November 5. The first session of the conference was held in the afternoon and was given over to a lecture on theater Tv by Dr. T. G. Veal, research engineer

MILWAUKEE'S FIRST THEATER TV UNIT



Checking the installation of the Tv projector at the foot of the balcony in the Warner Theatre (2500 seats) are, left to right: Adam Schneider, Local 164, graduate of the IA-RCA Tv school; D. MacMillan, RCA service engineer; Glenn C. Kalkhoff, president of Local 164, and C. W. Burns, Warner sound engineer. Schneider and Kalkhoff are projectionists at the Warner Theatre.

for Eastman Kodak Co. Dr. Veal's talk was most informative and gave the delegates a clear conception of the video art.

At the evening session it was agreed that all officers, present and future, will automatically become honorary delegates to future meetings, regardless of whether they are accredited delegates. Also agreed was that the Association will hold two meetings each year—Spring and Fall.

Not forgetting sentiment, the delegates sent a round-robin letter to P. A. McGuire, former advertising manager for International Projector Corp., who retired from all activities several years ago. Mac was an honored guest at many State gatherings, and the boys have a warm spot in their hearts for him.

Delegates present represented Locals 108, Geneva; 119, Auburn; 121, Niagara Falls; 253, Rochester; 272, Cortland; 311, Middletown; 324, Albany; 337, Utica; 376, Syracuse; 396, Binghamton; 474, Rome-Oneida; 480, Corning; 581, Batavia, and 609, Little Falls.

• We regret to record the death of E. P. Lenhoff, former secretary of Local 548, Paris, Texas. We never met E. P. personally, but we staked out some common ground via the correspondence route through the years. A wife and daughter survive—and to them our heartfelt sympathy.

• A note from our friend Ralph Root, Sr., long-time business representative for Local 236, Birmingham, Ala., informed us that his son, Ralph, Jr., an electronics engineer for RCA at Biggs Field, El Paso, Texas, was notified that he was being transferred to Washington, D. C., in charge of a most important project. A proud dad of a mighty fine son.

• Theater Tv was featured at the Allied Theater Owners Convention held last month at the Biltmore Hotel, New York. Several theater Tv systems were on display, each one attracting considerable attention from the visitors. Only the GPL, of all the Tv systems on display, utilized the services of a projectionist. We commend the "powers that be" be-

hind this system for their foresight in recognizing the fact that the projectionist is an important factor in the proper presentation of theater Tv. Elsewhere in this issue will be found an article relating to the lecture and demonstration of the GPL theater Tv system given at a recent meeting of the 25-30 Club of Greater New York.

• The recent IA executive board meeting, held in New York, brought in many officials from all parts of the country and afforded us an opportunity to get together with many of our old friends. It was particularly good to see Orin Jacobson, IA representative for the past 21 years, who was elected IA eighth vice-



ORIN JACOBSON
Tacoma, Wash., L. 175
man named 8th
vice-president of IA,
succeeding the late
Floyd Billingsley.

president to fill the vacancy created by the death of Floyd Billingsley, Local 162, San Francisco. Orin is a former official of Local 175, Tacoma, Wash., and for many years served as secretary of District No. 1.

• While chatting with R. J. Fisher, member of Local 253, Rochester, N. Y., we learned that Cal Bornkessel, old-time member and official of the Local, has recovered from a serious operation and is again working at the RKO Theater. Fisher, incidentally, was president of the Local back in 1914.

• A midnight banquet marked the 14th anniversary celebration last month for Local 703, Du Bois, Penna. Among the honored guests were IA Representatives

John B. Fitzgerald, Cleveland, and Larry Katz, Harrisburg. John Cheri, who has served as the Local's attorney since it was chartered in 1937, was the principal speaker of the evening.

Among those present were F. P. "Reel" McCoy and Phil Bordonaro, Local 444, New Kensington-Tarentum; a delegation from Pittsburgh Local 171 headed by Martin Torreano, president; Bill Thompson, business representative; James Sipe, secretary, and the entire Local 171 executive board.

• Local 343, Omaha, Neb., lost one of its oldest members by the death last month of Frank A. Lewis at the age of 91. Lewis worked in many Omaha theaters, and although he retired a number of years ago, he still retained his card in the Local.

• We are amused to see how some men, important figures in their particular fields, become as helpless as children when they are indisposed. Recently, while on a visit to New York with his wife, Bert Ryde, business representative for Buffalo Local 233, fell ill. Mrs. Ryde lost no time in bundling him up and, despite all his protestations, got him off on the train headed for home. Bert, the self-assured and confident union official, meekly submitted and later admitted, although somewhat reluctantly, that he had bowed to superior intelligence.

• History sure do repeat itself—in this case for Fred Raoul, general secretary-treasurer of the IA. About 27 years ago Fred broke a leg while on a Florida sojourn. Recently, after dropping off Orin M. Jacobson, newly-named IA 8th vice-president (the Tacoma lucky boy) at his destination, the Raoul car was hit by another car manned by a group of teen-agers.

The smash-up resulted in a ditto break of the same leg for Fred, while Mrs. Raoul sustained a broken thumb. Fred will be incapacitated for some weeks.

Mr. Jacobson? Lucky Boy arrived safely at his destination.

• William P. Covert, 2nd IA vice-president and business representative for Toronto Local 173, recently concluded negotiations with the exhibitors in his jurisdiction which provide for substantial increases for the Local. The new contracts with Famous Players and its subsidiaries allow a wage increase of \$5.25 per week per man, plus \$10 per

WILLIAM P. COVERT
IA vice-president and
business rep. of
Toronto L. 173
gains wage tilt in
Famous Players; (Canada)
theaters.



week cost-of-living bonus. Since September last, the cost-of-living bonus has been increased 50c per week.

The independent houses agreed to a straight increase of \$10 per week per man, plus paid vacations which in some instances extend to three weeks annually. Projectionists employed in the film exchanges also received a \$10 a week increase. The booth cost in one of the theaters in Oshawa was boosted an additional \$34 per week, or \$17 per week per man.

Negotiations for the Local were conducted by Covert, R. Sturgess, and Pat Travers, ably assisted by executive board members Roy O'Connor, Jack Hills, Norman Tanner, Lou Lodge, Art Milligan, and Geo. Jones.

• Joe Cifre, member of Boston Local 182 and head of the theater equipment supply firm that bears his name, is conducting a one-man drive to spur the collection of copper drippings. Joe has appealed to all IA Local Unions, theater owners, and theater managers throughout New England to expand every effort to salvage every last bit of copper scrap, to be sent to his office at 44 Winchester St., Boston 16, Mass. He will see that the scrap is forwarded to the proper governmental agency.

• Completion of the two-year contract negotiated last month between IA West Coast Locals and the Association of Motion Picture Producers was delayed due to a misunderstanding over the interpretation of the cost-of-living wage increase provided for in the agreement. However, we have been reliably informed that the producers have agreed to the IA's original demand to reopen wage discussions when the cost-of-living is increased 5% or more, the calculating basis to be the October 15 Bureau of Labor Statistics Index.

WILKES-BARRE, PA., MEN (IA LOCAL 325) ADMIRE THEIR NEW PROJECTION EQUIPMENT

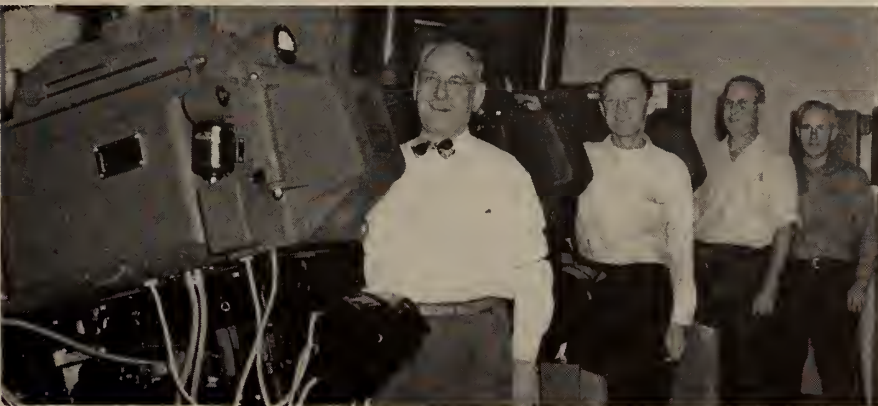

Showing the first installation of the new Ashcraft Hydro-Arc lamp in the Penna. area at the Paramount Theatre. Left to right: Harvey Eggleston, president of L. 325; Joseph Malloy, Robert Platt, Jr., secretary-treasurer of L. 325, and William Platt.

Theatre Screen Brightness Survey

A Report by the SMPTE Screen

Brightness Committee†

W. W. LOZIER, Chairman

A PRELIMINARY survey of 18 theaters by the Screen Brightness Committee in 1947 disclosed interesting indications of theater screen illumination practice in this country, but was inconclusive because the theaters covered represented too limited a sampling. A more extensive survey was not carried out at that time because of the lack of a suitable meter.

More recently, General Electric Co. placed at the disposal of the Committee a meter which is better adapted to a theater survey. Consequently, during the summer of 1950, the Committee undertook a survey of screen illumination and related factors in 100 representative indoor theaters. It was the purpose in this larger survey to cover a more representative segment of the theaters in this country and to obtain dependable data concerning their practices, with the underlying thought that observation and

† Jour. of SMPTE, Sept. 1951, p. 238

SCREEN BRIGHTNESS COMMITTEE THEATER SURVEY

THEATER _____
ADDRESS _____

DATE _____
REPORTED BY _____

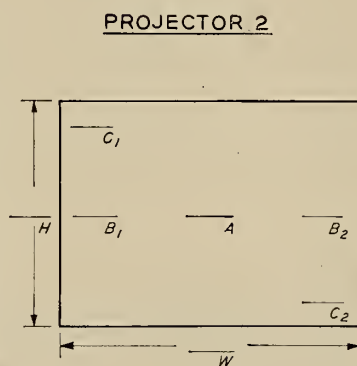
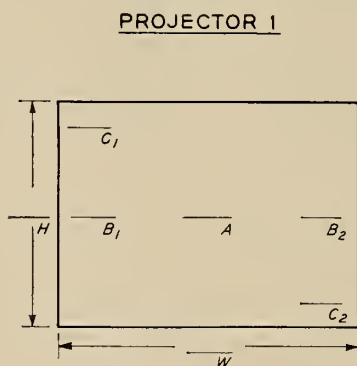

READ INTENSITY ON THE SCREEN IN FOOT-CANDLES AT THE FIVE POSITIONS INDICATED. "C₁" AND "C₂" ARE LOCATED $\frac{1}{20}$ OF H FROM EDGES AND $\frac{1}{20}$ OF W FROM SIDES. "B₁" AND "B₂" ARE ON THE HORIZONTAL CENTER AND $\frac{1}{20}$ OF W FROM SIDES. "A" IS IN THE EXACT CENTER.

SCREEN AREA
AREA IN SQUARE FEET = $H \times W =$ (1)

SCREEN LIGHT INTENSITY AND DISTRIBUTION
RATIO $\frac{B_1 + B_2}{2} \times \frac{1}{A} =$
RATIO $\frac{C_1 + C_2}{2} \times \frac{1}{A} =$

SCREEN LUMEN CALCULATION
 $A \times 2 =$
 $B_1 + B_2 =$
 $\frac{C_1 + C_2}{2} =$
TOTAL = _____
WEIGHTED AVG. = $\frac{\text{TOTAL}}{5} =$ (2)
SCREEN LUMENS = (1) \times (2) =

SCREEN AREA
AREA IN SQUARE FEET = $H \times W =$ (1)

SCREEN LIGHT INTENSITY AND DISTRIBUTION
RATIO $\frac{B_1 + B_2}{2} \times \frac{1}{A} =$
RATIO $\frac{C_1 + C_2}{2} \times \frac{1}{A} =$

SCREEN LUMEN CALCULATION
 $A \times 2 =$
 $B_1 + B_2 =$
 $\frac{C_1 + C_2}{2} =$
TOTAL = _____
WEIGHTED AVG. = $\frac{\text{TOTAL}}{5} =$ (2)
SCREEN LUMENS = (1) \times (2) =

FIG. 1. Sample data form for incident screen illumination.

SCREEN BRIGHTNESS SURVEY

CENTER SCREEN BRIGHTNESS AND REFLECTIVITY

Incident Illumination \times Screen Reflectivity = Screen Brightness

METHOD A

When using a combination illumination and brightness meter, measure center of screen values of incident illumination and Screen Brightness, and calculate Screen Reflectivity, using the above equation.

METHOD B

When using a reflectivity meter, measure Screen Reflectivity and combine with Incident Illumination to calculate Screen Brightness, using the above equation.

	PROJ. 1	PROJ. 2
Incident Illumination Ft.-Candles	_____	_____
Screen Reflectivity, %	_____	_____
Screen Brightness Ft.-Lamberts	_____	_____

FIG. 2. Sample data form for screen reflectivity and screen brightness.

discussion of any undesirable conditions would promote better projection.

At the present time, results are available on 125 theaters, representing all except the Southeast and Pacific sections of the U. S. It is believed that these re-

SCREEN BRIGHTNESS SURVEY

Projection Data

1. Projection Angle
2. Arc Lamp Type
3. Positive Carbon
4. Negative Carbon
5. Arc Amperes
6. Arc Volts
7. Projection Lens
 - (a) F-Number
 - (b) Focal Length
 - (c) Surface Coated
8. Type of Shutter
 - (a) Degree Opening
9. Draft Glass Type
10. Heat Filter Type
11. Projection Port Glass
12. Type of Power Supply
 - (a) Rating in Amperes
 - (b) Rating in Volts
 - (c) Operating Voltage

Auditorium Data

1. Seating Capacity

FIG. 3. Sample theater data form.

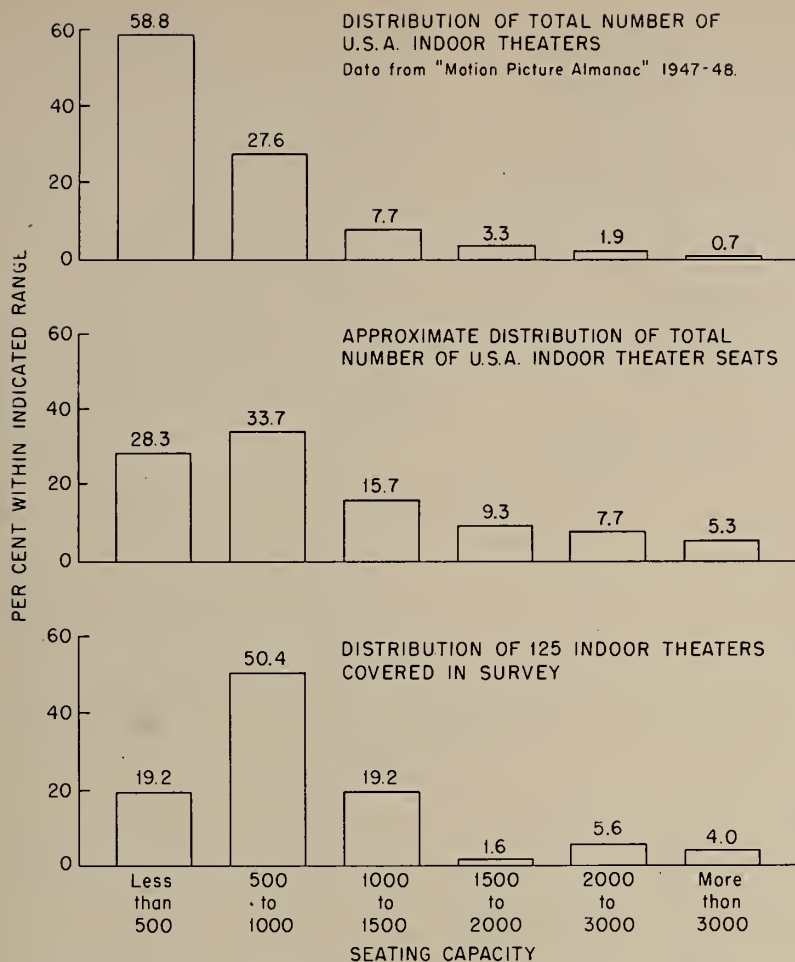

FIG. 4. Capacities of survey theaters and total indoor theaters.

sults would not be greatly changed by representative coverage of these additional areas.

During the course of this survey, the Motion Picture Research Council became interested in carrying out a parallel survey in the West Coast studio review rooms used for viewing 35-mm pictures. Through their cooperation, we are able to include in this report the results on 18 review rooms.

Methods and Instruments

In contrast with the previous survey, all of the measurements in the present survey were made with an objective-type instrument requiring no visual photometric balance. Nearly all of the measurements were made with the two-cell G. E. combination screen illumination-screen brightness meter. A few measurements were made employing a simple foot-candle meter in combination with an improvised device for measuring the screen reflectivity.

Data forms were simplified somewhat from those used in the 1947 survey and are illustrated in Figs. 1 to 3.

Classes of Theaters Surveyed

The 1947 survey was heavily weighted by the large downtown theaters in large

cities. An effort was made in this survey to cover a wider range of types and sizes of indoor theaters. Fig. 4 shows the distribution of seating capacities among the 125 theaters surveyed. It also shows the distribution of seating capacities among the indoor theaters of the U. S. expressed both on the basis of percentage

of theaters in various seating ranges and also as the percentage of the total theater seating capacity falling in the different seating-capacity ranges.

It is seen that the distribution of theaters covered in our survey corresponds more closely to the distribution of the total U. S. theater seating capacity than to the distribution of number of theaters among the various seating ranges. While the less-than-500-seat theaters account for over half of the total number of indoor theaters, they account for only a little more than one-quarter of the total number of seats.

Figure 5 gives the distribution of screen widths measured thus far. All but a small fraction of the screens were between 14 and 24 ft. in width, with the average at approximately 18 to 20 ft.

Screen Brightness Distribution

The distributions of screen brightness encountered with 36 review-room projectors and 245 indoor-theater projectors are given in Fig. 6. The present ASA standard limits, also shown in Fig. 6, call for a brightness between 9 and 14 ft.-L. The indoor theaters ranged in brightness from 3.4 to 53 ft.-L, with approximately one-quarter below and about one-half within the ASA standard range. Two theaters which were equipped with highly directional "silver" screens had a central maximum screen brightness in the range of 30 to 53 ft.-L. In the case of the review rooms, almost two-thirds were within the standard limits, and most of the remaining third exceeded the maximum limit.

Over-All Screen Illumination

Figure 7 shows the distribution of illumination over the screen expressed as a ratio of side-to-center intensity of incident illumination. Side distribution ranged from 40 to 94% for the indoor theaters, with approximately 85% of the

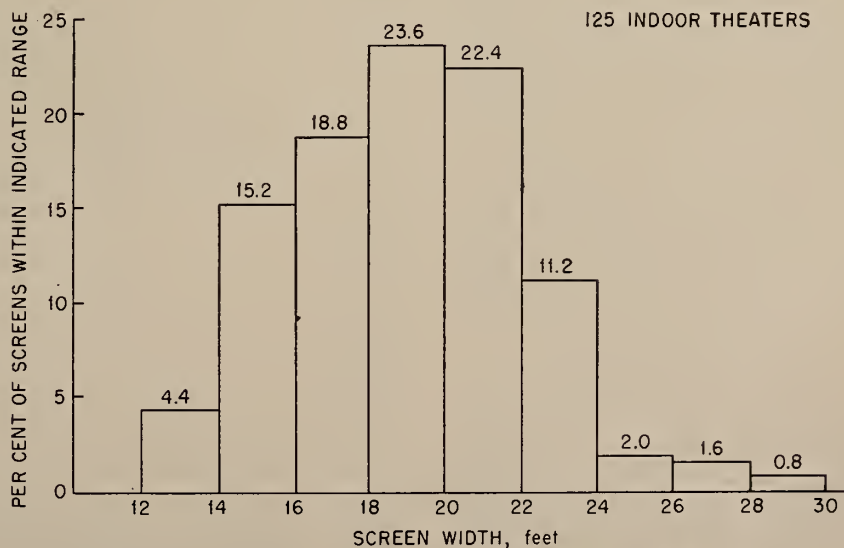

FIG. 5. Distribution of screen widths covered in the survey.

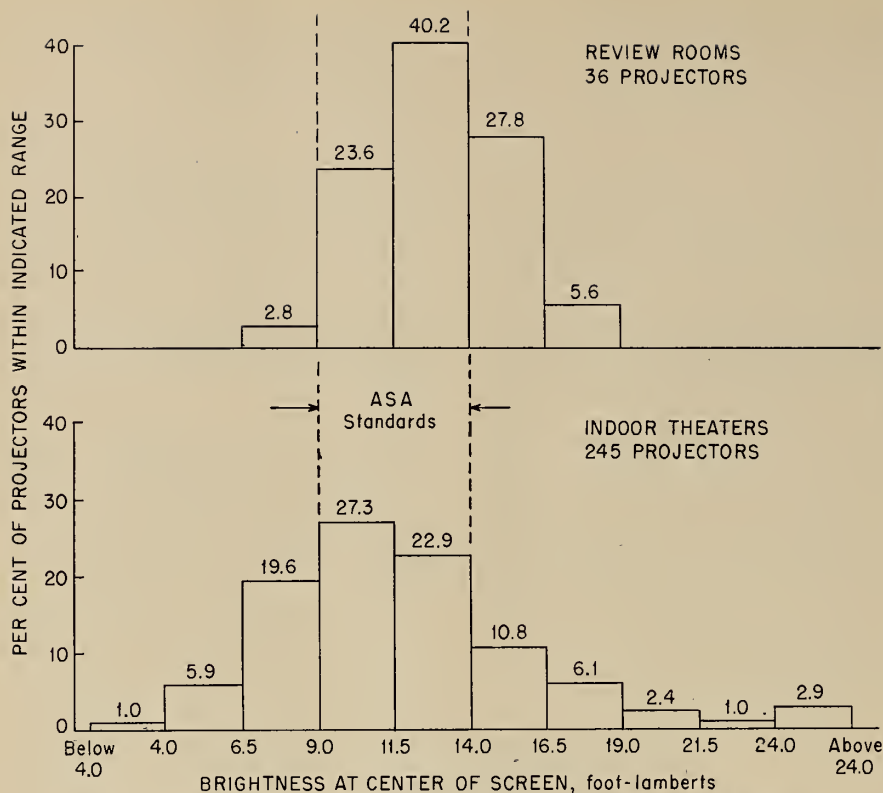

FIG. 6. Distribution of screen brightness obtained in the survey.

projectors falling between 50 and 80% distribution ratios. The most frequent distribution ratio was 60-70%.

The review rooms differ radically from the indoor theaters by having a much more uniform distribution of illumination over the screen. Of the review-room projectors, 85% produced a side distribution between 80 and 100%.

Review-Room Screen Problem

This more uniform screen distribution reflects the review-room problem of small screen size and excess illumination; defocusing the light source to produce a uniform distribution is one way which has been used to reduce excess screen brightness. It means, however, that motion pictures are viewed in these review rooms under conditions very different from those prevailing in motion picture theaters.

Figure 8 gives similar information on the ratio of corner-to-center incident intensity. Corner distributions are, in each case, approximately 10 to 15% lower than the side distribution and ranged from 26 to 83%. Fig. 8. shows, however, the same basic pattern as Fig. 7.

Screen Reflectivity Range

Less than half of the indoor theater screens had reflectivities in the 70 to 80% range, typical of a matte white screen in good condition. Over 40% of the screens ranged from 70 down to 32% reflectivity. Approximately 10% of the screens had reflectivities between

80 and 100%. Five "silver" screens were in the range of 150 to 250%. A total of eight "silver" screens are included in Fig. 9.

The review-room screens, on the average, tended to have lower reflectivities than the indoor theaters, but not as great a range of extremes. This may

again reflect the problem of excess illumination and the fact that even a deteriorated screen will produce adequate brightness with the small-size screens employed. However, if the low reflectivity is the result of deterioration, then such screens may also have undergone color change with resultant distortion of color motion pictures.

25% of Total Sub-Standard

This survey of 125 indoor theaters has shown that the screen brightness falls within the recommended range for a little over half of the projectors, but that almost one-quarter of the theaters are below the recommended standards. The distribution of illumination over the indoor theater screens ranges from very uniform to extremely nonuniform. Screen reflectivity for the indoor theaters ranges from values typical of screens in good condition all the way down to values representing over 50% deterioration.

The West Coast review rooms generally show screen brightness within or a little above the recommended standards for indoor theaters. However, the review rooms differ from indoor theaters in having exceptionally uniform distribution of illumination over the screen. Review-room screen reflectivities show a lower average value than, but not nearly as great a spread of extreme values as, the indoor theater screens.

Three-Year Improvement Noted

Compared with the 1947 preliminary survey, the present one shows an even wider range of screen brightness values, but only about one-half as great a pro-

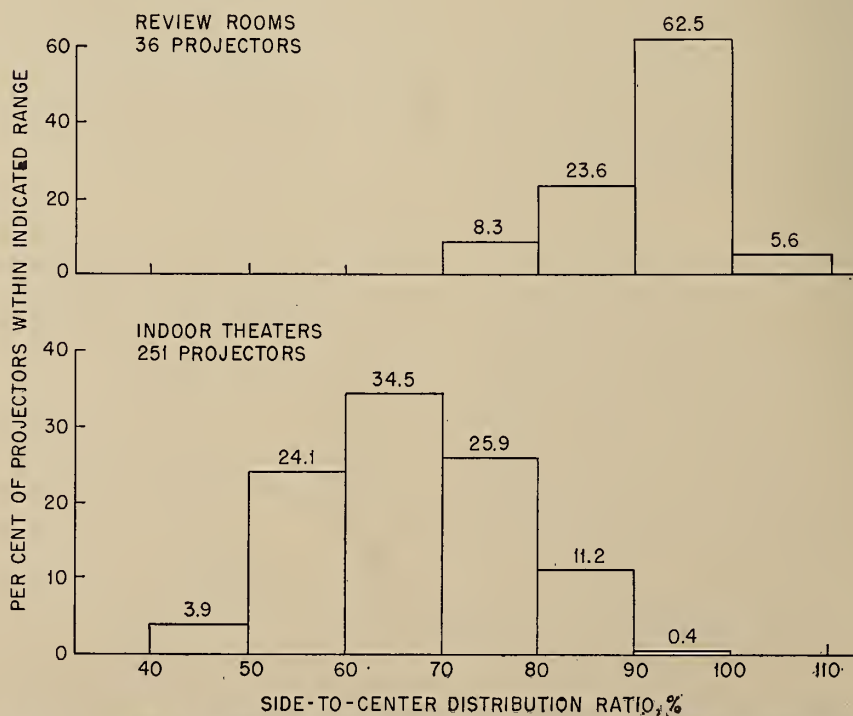

FIG. 7. Range of side-to-center distribution ratios of incident illumination obtained in the survey.

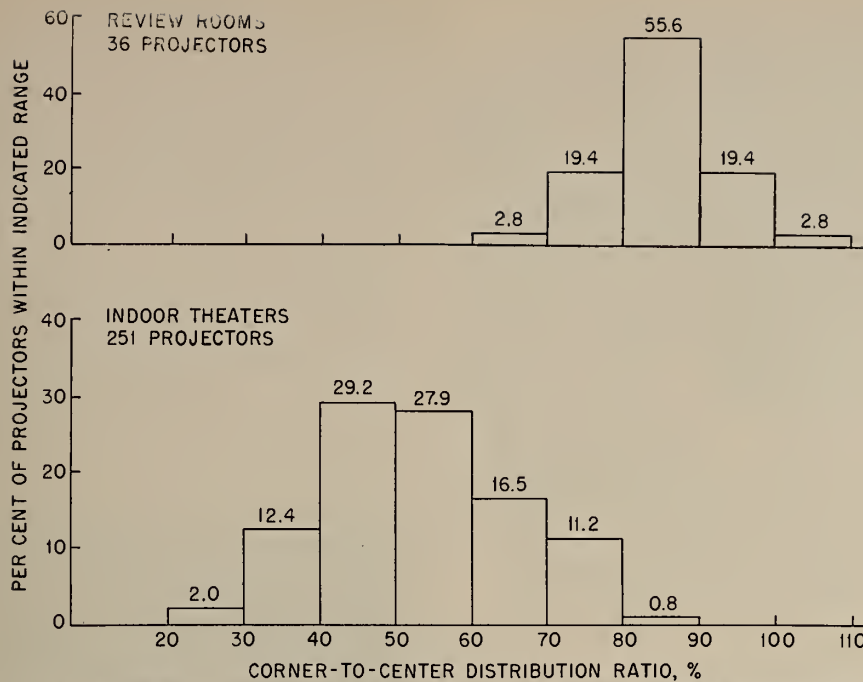

FIG. 8. Range of corner-to-center distribution ratios of incident illumination obtained in the survey.

portion of theaters below the recommended minimum brightness. Other factors studied, such as side and corner screen distribution ratio, cover approximately the same ranges as observed in the earlier survey. The screen reflectivities extend over a much wider range, including both some exceptionally low

values and also a number of "silver" screens of extremely high reflectivity.

It is expected that the results of this survey will assist in the formulation of an eventual Committee recommendation for improvement of projection practice in theaters. In the meantime, however, it is believed that better attention to

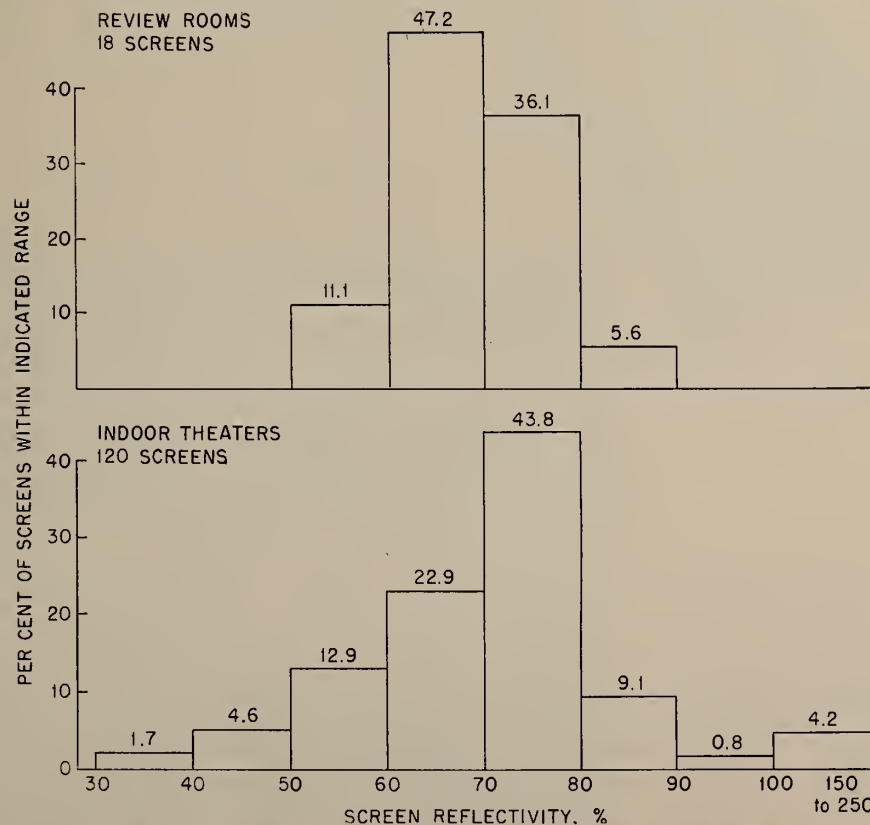

FIG. 9. Range of screen reflectivities obtained in the survey.

details of operation and maintenance can reduce the wide range of screen brightness observed and eliminate many of the extreme values. It can also eliminate many of the highly nonuniform distributions of illumination over the screen and thereby remove some of the objectionable conditions prevalent.

The findings of this survey in the West Coast review rooms are being considered by the Research Council and West Coast studios in relation to their program of improving review-room practices.

Projectionists' Fine Cooperation

The Screen Brightness Committee are indebted to many people for assistance in the conduction of this survey. Theater projectionists and their organization, the IATSE, have been most cooperative in making their facilities and assistance available to us.

The Research Council took the initiative in obtaining the data on the West Coast review rooms. Without the fine cooperation of these individuals and groups, this survey would have been difficult if not impossible.

Par's New Sound Track Position

A change in the present proposed standards for placement of the sound track on 35-mm film has been urged by Loren L. Ryder, sound director of Paramount Pictures. In a report to the SMPTE, Ryder suggested that the magnetic sound track be placed 131 mils (131/1000th of an inch) from the sprocket hole of the film instead of the present 50 mils. This suggestion, he said, is based on extensive studies made of both methods, with results showing that interference from sprocket holes is encountered in the 50 to 100 mil area.

In the ensuing discussion, representatives of three companies presented data tending to refute the Paramount studies.

SMPTE Proposals Pending

The proposed standards of 35-mm sound track placement have been adopted by the M. P. Research Council. The SMPTE sound committee has been studying standards for three years and last July published the proposed standards for further study by members. Action by the sound committee is still to be taken prior to submitting final proposed standards to the ASA.

During the discussion, Ryder stated flatly that Paramount will continue to record sound tracks at 131 mils.

Another Theater Tv Circuit

Latest Eastern circuit to announce plans for theater Tv purchases is Walter Reade Theaters, operating throughout New Jersey. Ten houses in this group will be so equipped as soon as adequate line facilities are made available, probably by the end of this year.

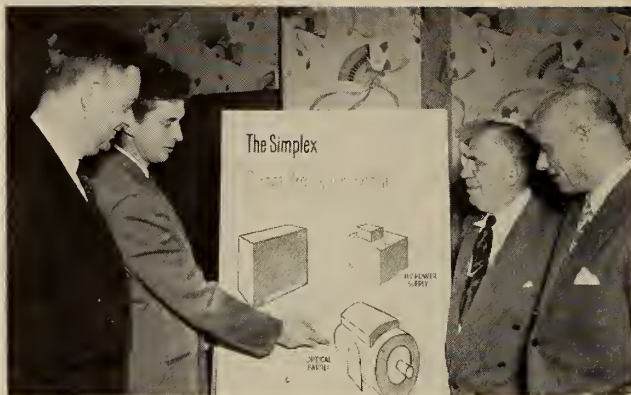

Blair Foulds and Dr. F. N. Gillette (left) of GPL, and Ed Daugherty (L. 384, Hudson County, N. J.), and Harry Mackler (L. 306, N. Y. City), vice-president and president, respectively of the 25-30 Club.

GPL-NTS Theater Tv Attracts 400 to 25-30 Club Meeting

MORE than 400 projectionists in the Metropolitan New York area were given a great show at the November meeting of the 25-30 Club in the Hotel Belvedere ballroom when General Precision Laboratory and National Theater Supply Co. joined forces to stage a lecture-demonstration of the GPL theater Tv direct-projection and intermediate-film systems.

Top technical and executive talent from both companies combined to make this a memorable evening in the history of manufacturer-distributor-projectionist relations.

Physical limitations of the meeting place, no less than safety factors, prevented the installation of the direct-projection equipment, as every projectionist will understand, but this system was described in detail orally with the aid of a fine series of slides. The intermediate system featured a film that was taken off the air, developed and projected *via* the GPL 56-second transition method from air-pickup to screen projection.

Discussion Session Spirited

Following the lecture-demonstration was a lively question-and-answer period which covered many phases of installation and operation. Happily, there was no abrupt termination of the discussion period, as so often happens at such meetings: the session was not ended until there were no more questions forthcoming.

The meeting reflected great credit on the GPL-NTS companies and on their staffs who made arrangements for and carried out the program. Our own Johnnie McGinley, staff projectionist for GPL (Local 650, Westchester, N. Y.) did a fine all-around job.

It is expected that GPL-NTS will sponsor similar meetings in various sec-

tions throughout the U. S., an intent which prompts a few observations which may contribute in some small measure to the success of similar demonstrations in the future.

At such gatherings it is a natural tendency for projectionists to engage in considerable fraternizing, particularly when they hail from a wide geographical area and have few opportunities to get together and exchange news and views. This is all to the good, but such socializing by even a very small minority detracts no little from the value of the meeting for the large majority—say, 95%—of those who come to be informed about that which is of vital importance to their work.

Instruction, Not 'Sales,' the Aim

Topmost in mind should be the fact that such lecture-demonstrations are not "sales" meetings in even the remotest

sense; they represent an effort on the part of manufacturers to convey important information to the craft, those who operate their equipments day after day. Not infrequently the cost of such demonstrations in man-hours, effort and expense is considerable, running sometimes into four figures.

The craft can show its appreciation to the sponsor of such meetings by inviting the five-percenters to do their socializing outside the meeting area.

Getting back on the mainline, it needs to be set down here that the GPL-NTS Tv show for the 25-30 Club is merely an extension of the policy of extremely close



TOP PHOTO: From Westchester County, N. Y. (l. to r.)—Joe Monaco, bus. rep. of Local 366; and from Local 650: Irving Weiss, pres., Fred Thome, bus. rep., and Anthony Dente, vice-pres.

BOTTOM PHOTO: From Hudson County, N. Y., Local 384 (l. to r.)—Frank Maurus, Frank Mandrake, pres.; Albert De Titta, and Ed Daugherty, vice-pres. of 25-30 Club.

From Local 306: Ernie Lang, sec.; Herman Borritz, exec. board; Harry Storin, vice-pres.; Dick Cancellare and Dave Garden, exec. board, and Dave Narcey, retirement board.



Extreme left: Ernie Lang, L. 306; Ed Daugherty, Allen G. Smith, NTS New York branch manager; Harry Mackler, John Sims, GPL; Ben Stern, treas., and Morris Klapholtz, sec. of the 25-30 Club. Kneeling: Julius Wetzler, sgt.-at-arms of 25-30 Club.



eral Precision Equipment group in every section of the country down through the years.

It was a well-nigh impossible task to obtain, or to list here, all those who attended the GPL-NTS demonstration (and for this IP asks the indulgence of those not mentioned here), but among those noted were:

From GPL: Blair Foulds, John Sims, F. N. Gillette, T. P. Dewhirst, Bill Borgborg, and Al Mayer. From NTS: Allen G. Smith, N. Y. branch manager; John Krulish, Bill Nafash, Sam Selden. From INTERNATIONAL PROJECTOR CORP.: Admiral R. B. Tomkins (Ret.), president; Arthur E. Meyer, vice-president, and Bill Hecht.

Also, Dave Joy and Paul Reis, National Carbon Co.; Bob Goldblatt, first president of Local 306 and a founder of the 25-30 Club; a large delegation from Westchester County, N. Y., Local 650, including Irving Weiss, president; Anthony Dente, vice-president, Fred Thome, business agent, and Larry Sabatino; Joe Monaco, business agent of Westchester Local 366; Joe Engel and Al Sweeney, Long Island, N. Y., Local 640; Roy Fisher (Ethyloid cement), Local 253, Rochester, N. Y., and among the many others those pictured in this story.

Show Filmless Camera on Coast

Demonstration on the West Coast of a pilot model of a television camera capable of recording images on magnetic tape rather than on film is expected to spur research work on such a project now underway in several major laboratories.

Device demonstrated in Hollywood utilizes ordinary sound-recording plastic tape. The images, recorded from a Tv show, were reportedly blurred and indistinct, but sponsors assert that they are far enough along with their research to eliminate this defect. Sponsor, incidentally, is the electronic division of Bing Crosby Enterprises.

The recorder does not actually take a picture but records Tv images and sound on tape, from which programs are played back on a Tv receiver. Mass production is slated to begin within eight months.

Theater Tv Hearings on Feb. 25

Hearings on theater Tv, scheduled to start Nov. 26 before the Federal Communications Commission, have been postponed until Feb. 25, 1952. The time for filing in the proceeding also was extended from Oct. 26 to Jan. 25. Allocations of frequencies for theatre Tv and the adoption of rules and regulations for the proposed service will be the topics at the hearings.



Your patrons will notice the difference! Super Snaplites give you Sharper Pictures, More Illumination, Greater Contrast and Definition.



Clear
Crisp Pictures
with
SUPER SNAPLITE
f/1.9
PROJECTION LENSES

For the Best in Projection use Super Snaplites . . . the only Projection Lenses to give you a true speed of f/1.9 in every focal length up to 7 inches.

Ask for Bulletins
207 and 209

KOLLMORGEN
2 Franklin Avenue
Brooklyn 11, New York

Optical CORPORATION

"YOU GET MORE LIGHT WITH SUPER SNAPLITE"

PHOTOGRAPHIC OPTICS

(Continued from page 15)

lows extension double normal—our lens will be working at an effective relative aperture of twice that marked on the lens. We would then have to quadruple our exposure time. In fact, the effective relative aperture is given by the product of the stop number for infinity and the magnification plus one.

Fixing Pictorial Perspective

The nodal points, as defined previously, are points associated with a lens having the interesting property that a ray of light directed at one will emerge from the other undeviated. Expressed differently, a ray of light striking the first nodal point will leave the second parallel

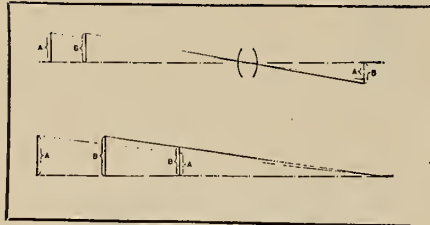

FIG. 25. Perspective I.

to its original direction, and a fan of rays entering the first nodal point will likewise constitute a fan of rays leaving the second. In this manner all the rays forming an image on the film can be considered as having passed through two points of the lens.

The first nodal point constitutes the single eye of the lens, which sees the scene in a certain manner. If a frame were to be held before the first nodal point, the objects in the scene would be in certain relationships to each other, determined, among other things, by the size of the frame and its distance from the nodal point. These relationships we summarize as *perspective*.

If this frame is the conjugate of the borders of the negative, our pictorial perspective is then fixed, and if we wish to see the scene as the camera saw it, we must place our eye in the position occupied by the second nodal point. Only then could we speak of having the correct perspective (Fig. 25).

Human Eye Characteristics

Very few people can accommodate at distances less than 10 inches, which is taken as the shortest reading distance,

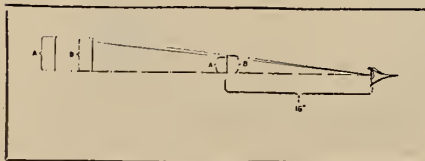

FIG. 26. Perspective II.

or near point. Most camera lenses have focal lengths less than this, so contact prints inevitably yield a certain perspective distortion, unless the lens used had an equivalent focal length of 10 inches or more. One way of getting the eye in the proper position to recover the true perspective is by enlarging our negatives. In accordance with these considerations the rule is to enlarge so that the effective focal length is equal to the anticipated eye-to-print distance.

For instance, if a 2-inch lens were used to make the miniature negative, and hand-held prints were desired, to be viewed at about 14 inches, we would want the perspective of a 14-inch lens. We could get this by enlarging our negative 7 times. We could achieve the same thing by viewing our miniature transparencies at 7 times magnification. If higher magnification is employed in enlarging, the position accordingly moves outward (Fig. 26).

[TO BE CONTINUED]

Vallen Needed—and Got—a Pro

Ingenuity, no less than the versatile manner in which engineered component units may be employed, are reflected in a recent installation of a curtain control by Vallen, Inc., Akron, Ohio. The job was a challenge to the accumulated experience of show-business people, which meant that its execution was accomplished strictly on the basis of know-how supplemented by the doing-it which can only stem from action *on the scene*.

One of the major requirements in the new Children's Cancer Research Foundation in Boston—the first and only building of its kind in the world—was a surgical amphitheatre where cancer operations could be conducted before doctors, nurses and technicians. To be of maximum use, the amphitheatre had to incorporate a revolving stage, chalkboards and projection screens for lecture use; yet, it had also to provide complete privacy on the stage when desired or necessary. This was no easy problem.

How the Job Was Done

A 10-foot diameter turntable installation that permits revolving stage through a full 360° circle, insuring full unobstructed vision for all observers.

Two chalkboards, one tackboard, and a projection screen provide ample facilities for lecture notes and diagrams in full view of the auditors. Each board is independently operated by a Vallen, Jr., curtain control, permitting raising or lowering the boards quickly, smoothly and dependably in any sequence.

The cyclorama curtain is hung on Vallen curved curtain track (No. 153) which incorporates the exclusive Vallen rear-fold feature, and follows the contour of the stage. The front curtain hangs on

Cyclorama Draw Curtain on rear-fold track behind turntable

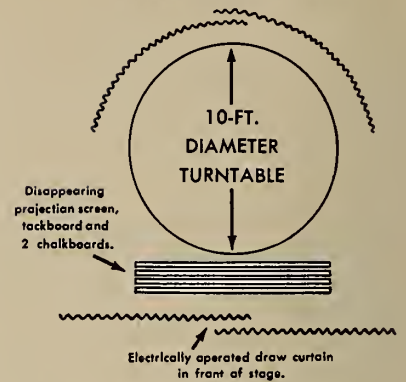

Details of unique Vallen installation.

Vallen all-steel, noiseless safety track (No. 150) and can be opened or closed effortlessly by means of a Vallen Curtain control. Thus the entire stage area can be closed off when necessary.

Naturally, one of our boys—Joe Cifre of Boston Local 182—handled the job.

Electronic Vocational Guide

TV AND ELECTRONICS AS A CAREER is the title of a new book just published by John F. Rider, Inc., 480 Canal St., New York 13, N. Y. Engineering, broadcasting, manufacturing, servicing, parts and receiver distributing, sales representation, retailing, and electronics in the armed forces are discussed by top authorities, who wrote on their special fields. Also, there are included appendices on pay scales for broadcast personnel and Tv service branch personnel, electrical engineering curriculum, and educational institutes in the U. S. teaching radio, television, and electronics.

All the why's and wherefore's of the electronics industry are explained for the newcomer embarking on a career, and the electronics "oltimer" desiring to switch to another field of specialization within the industry. Written in an easy-to-read style, the book contains 325 pages with 136 illustrations in a cloth binding. Price: \$4.95.

Christmas Seal Campaign Opens

Xmas Seals have helped many people in show business—and show business never fails to remember its friends.

Support for the research and other work of the voluntary tuberculosis associations is derived from the people through their purchase of Christmas Seals. Each year, at the Christmas Season, the local tuberculosis associations conduct the sale of Christmas Seals by mail. Sheets of Christmas Seals are mailed to residents of the community, who make their returns by mail. Personal solicitation, either at business or at home, is therefore avoided.

Christmas Seals have become a holiday tradition in this country, where they have

been sold since 1907. The first sale was in Wilmington, Del., and was sponsored by the late Emily P. Bissell to raise funds to help some doctors continue their treatment of a small group of needy patients. The doctors needed \$300. Through the sale of Christmas Seals, Miss Bissell raised \$3,000 for their work. The sale of Christmas Seals had been inaugurated in Denmark in 1904, the idea of a postal employee named Einar Holboell.

Local Communities Retain 94%

Each year 94% of the money raised by the sale of Christmas Seals remains in the state where it was contributed to support local and state tuberculosis control programs. The remaining six per cent is forwarded to the National Tuberculosis Association. At least one-sixth of this percentage is used for medical and social research.

Each year a different design is used for the Christmas Seal. This year a jolly Santa Claus smiles from the Christmas Seal. Whatever the design of the Christmas Seal, it always bears the Double-Barred Cross, registered emblem of the National Tuberculosis Association and its 3,000 affiliates. An adaptation of the Cross of Lorraine, the Double-Barred Cross is also the emblem of the worldwide crusade against tuberculosis.

NEWS PROJECTIONS

RADIO-TV manufacturers deny creation of a "war chest" to buck theater Tv. Assert that both enterprises can "live together." Oh, yeah? . . . N. Y. State highest court has confirmed ban on Italian import film "The Miracle." Appeal will be made to U. S. Supreme Court. . . . Roy Rogers won court action to bar Republic Pic from peddling his films to Tv nets. Decision not universally applicable, because of special clauses in Rogers contract. Gene Autry proceeding likewise. . . . First nine months of 1951 saw 93 new enclosed theaters and 185 drive-ins opened. . . . Universal, Monogram, Paramount and Republic now making pics for Tv nets. Won't be long now. . . . Skouras Theaters (N. Y.) flat \$1 admission for an entire family regardless of size (plus individual tax) deemed a great success and will be a fixed Friday night policy. Largest family to show up numbered 11. . . . Decca Records now controls Universal Pictures, thus giving a double-barrelled entree into radio-Tv—transcriptions and pics. . . .

Before they even get off first base on regular theater Tv, exhibitors are mulling plans for educational and industrial

Tv—morning shows, etc. . . . Half of 20th Century-Fox features for 1952 release will be in Technicolor. . . . Six weeks of special children's Saturday matinee shows for \$1 has been set by Balaban & Katz Norton Theater in Chicago, Parent and teacher groups cooperating. . . . Drake Hotel, Chicago, the scene for next SMPTE convention, April 21-25 next. . . . NPA has sent out 20,000 letters to theaters anent carbon copper salvage. . . . NPA says that military use of raw film stock will be held to a point at which civilian requirements will not be strained. . . . Fight at a Baltimore, Md., arena on Nov. 2, a 10-rounder, with a supporting card, took in \$498 at the gate. Event was televised by CBS coast-to-coast. Savvy? . . . Those who yelled lustily that installment buying was a major cause of the box-office decline had red faces when both cuffio buying and b. o. take increased during Sept. . . . Bank night drawings for cash prizes will not be subject to the new "gamblers" tax, BIR ruled. . . . Wall St. sees movie attendance up from 6 to 8% over the past two months.

Your Very Best Buy
BUY U. S. SAVINGS BONDS

Old Type Lens



B&L Super Cinephor Lenses

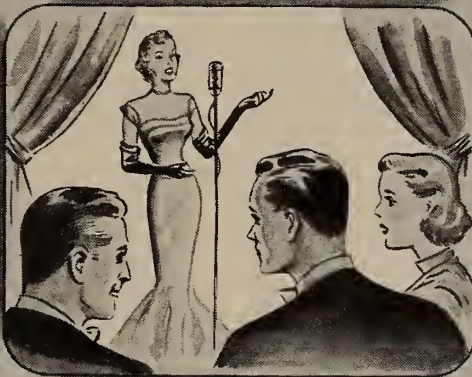

44% to 100% Brighter

For STEADY PROFITS you need

TODAY'S FINEST SCREEN IMAGE

Replace NOW with B&L Super Cinephor Lenses . . .
for Steady Patronage

Keep your patrons coming back! Don't let dim, eye-straining screen images cut profits. Show today's sharpest, brightest pictures . . . edge-to-edge brilliance and contrast . . . with B&L Super Cinephor lenses.



Write for complete information to Bausch & Lomb Optical Co.,
616-11 St. Paul Street, Rochester 2, N. Y.



Bausch & Lomb

Super Cinephor Projection Lenses

PROJECTIONIST SHOWMANSHIP

(Continued from page 14)

Running down film to check the threading should be done by means of the hand-wheel. This may be the soundhead fly-wheel on certain machines, the motor fly-wheel on certain others, and a motor drive gear on still others. The shutter and the intermittent flywheel should *never* be used for "turning over" a projector! Nor should the motor be switched on and off rapidly. Why? Because:

1. Any slack film in upper and lower magazines may suffer perforation damage because the motor starts the sprockets turning rather suddenly.
2. Serious burning of the switch contacts



• The NEW, improved, positive method of permanently patching all types and makes of film—8mm., 16mm., 35mm., Trucolor, Technicolor, Kodachrome, Nitrate and Safety Film.



Used and endorsed by Projectionists in countless theaters.

specifically for lasting Patches.

ESSANNAY ELECTRIC MANUFACTURING CO.
1438 North Clark Street Chicago 10, Illinois

occurs whenever the motor is turned off before it has attained normal running speed. (The starting windings of an A.C. motor consume much more current—many times more amperes—than the running windings. This current is so great that it exceeds the capacity of the switch momentarily.)

3. Switching the motor on again before it has entirely stopped turning inflicts a terrific strain on the projector gears, weakening the teeth or even stripping them. The main drive gear and the fiber spiral shutter gear of a popular make of projector head take the most punishment when this practice is indulged in. (Why does turning the motor on before it has completely stopped strain the gears? The powerful starting torque of the motor is *added* to the momentum of the already revolving gears.)

These are three very cogent reasons why the motor should *never* be used for running down film as a threading check. The handwheel should always be used. So much for that.

Sprocket Idler Adjustment

Now, then, damage to film perforations may also be minimized by seeing to it that all sprocket idlers are adjusted so that, when closed, the face of each idler is at a distance from the face of the sprocket equal to 2 thicknesses of safety film. Also, each idler should be properly centered laterally so that it does not shear one edge of the film. Roughened places on the edges of leaders indicate that badly centered idlers have taken a hunk out of them in somebody's theater.

With the equipment and prints in shipshape condition, with both projectors laced up with the first two reels of the show, and with both arclamps trimmed with carbons of adequate length, the show is ready to go on. In most theaters the projectionist's showmanship begins the very moment patrons enter the auditorium. Footlights are switched on to illuminate the "grand drape" colorfully and pleasingly; and mood music begins to issue from the curtained stage.

Overture Intermission Music

The matter of overture and intermission music warrants much more attention than it usually receives in small and medium-sized theaters. This writer has heard a circuit district manager (not now in the business, as you can well imagine) brush off pre-show music as an unimportant superfluity. And the writer knows that most circuit house managers are unfortunately too busied with a mass of trivia or too terrified by "economy" blasts to maintain a fresh and copious supply of new phonograph records of suitable types. Actually, the establishment of a "theater atmosphere" before the show by means of music is a mighty important aspect of the problem of keeping theater business alive.

Every projectionist, like anyone else, has his personal preferences in music. But the true showman keeps in mind the fact that a specific type of patron is attracted, as a rule, to a specific type of feature film. Persons who attend the theater to enjoy historical dramas and sophisticated drawing-room comedies are usually not the same people who crowd the theater to have a good time watching westerns, exciting action melodramas, and war films. There are children's pictures, women's pictures, and men's pictures. Slapstick comedies are enjoyed principally by persons of very low and very high intelligence; while in-between people derive the most enjoyment from light drama and "family-type" films.

Knowing all this, the projectionist finds it a simple matter to choose the right kind of overture and intermission music for each and every type of film program. He will therefore not use hill-billy songs to establish the atmosphere for a Bette Davis film, and he will not

ONLY
Century **PROJECTORS**
HAVE EVERYTHING

4-inch diam. lens mount
Water-cooled apertures
Oil-less Bearings

CENTURY'S high-efficiency projector with the NEW 4-inch diam. lens provides pictures of increased brightness and appeal—for even the largest drive-in screens.

CENTURY'S water-cooled aperture gives as much light with a 90 ampere arc as other projectors using a 180 ampere arc and heat filters!—Reduce power cost—Get sharper pictures—Save film.

CENTURY'S sealed, oil-less bearings and glass-hard gears reduce maintenance costs. No oil sprays or baths to mess up film or projection room.

You can SEE and HEAR the difference!

CENTURY PROJECTION AND SOUND SYSTEMS
See your dealer or write for information

CENTURY PROJECTOR CORPORATION
New York, N. Y.

SAVE CARBONS & COPPER!
"PHILLIPS" CARBON SAVERS
Machined and Handmade



Ask Your THEATRE SUPPLY DEALER

play Katchaturian's suites as a prelude to a Roy Rogers opus. The latter requires Western music; the former emotional, or dramatic, music.

Non-Sync Reproduction

It is always a good idea to listen to the non-sync reproduction from the auditorium once in a while as a check on sound quality. Poor frequency response—too "boomy" or too shrill and "scratchy"—may be remedied by correct impedance matching of the phonograph pickup to the first stage of amplification.

Phonograph needles—even those which are guaranteed to be "permanent"—must be renewed from time to time. And crystal pickup cartridges require replacement when they get weak and sound "thin" or "mushy." Excessive heat utterly ruins a crystal pickup; but even if properly cared for they seldom last longer than 4 or 5 years. Only the superior condenser-type pickup lasts practically forever; but these pickups require a special hookup and a pre-amplifier, like a condenser microphone or a photoelectric cell. Magnetic pickups are passé and rough on records because they are so heavy.

[TO BE CONTINUED]

FILM RESEARCH COUNCIL

(Continued from page 12)

of obtaining a directional screen which will permit of camera movement and yet offer a light gain of four or five times that presently available with the nondirectional screens.

Traveling matte composite photography presents many difficult problems. Presently, it is used in the industry only where there is no other way of making the required picture. This is true because the process is slow, expensive and it is difficult for many people to understand and appreciate the results which can be obtained.

The Research Council, in undertaking an investigation of this process, expects, therefore, to work toward a system which will overcome all three of these objections. It is hoped to develop a system which will be fast and inexpensive and will permit the director, cameraman and others concerned to see the composite result at the time the foreground is being photographed. This, of course, can be true only if the background material is already available on a motion picture film. That's a rather ambitious undertaking because it involves problems of optics, photographic materials, lighting and electronics. Preliminary studies, however, lead to the belief that these highly desirable results can be achieved

The expected improvements in this

rather old form of composite photography appear possible because of improvements which have been made in photographic film base, emulsions and electronic developments.

Projected Still Backgrounds

The use of projected still backgrounds has long been quite a problem, particularly where color is involved, much of the difficulty arising from the instability of the colors under the high temperature and ultraviolet light conditions which prevail. A further difficulty has been the problem of matching the foreground and

background colors, since the foreground is an original and the background is a dupe.

These difficulties were demonstrated with a frame of a 35-mm color print [which accompanied this paper but cannot be reproduced in color herein] in which the lower left-hand quadrant is a direct photograph of a color chart, and the other three quadrants are occupied by projected reproductions of the same color chart. Two of these are still projections and the third is a motion picture projection.

While none of these match the original,

Theatre TV

Demands Experience and Specialists

—RCA SERVICE

has both



Only from RCA Service do you get the *experience* that comes from installing and maintaining more theatre TV systems than any other service organization—anywhere. Only from RCA Service do you get *specialists* trained in the television laboratories and factories of the pioneer in theatre TV.

4 ways RCA SERVICE can help you

- 1 **Survey and help** solve the special TV application problems relating to your theatre.
- 2 **Supervise** the installation, adjustment and testing of all video equipment, coaxial lines and antennas.
- 3 **Give instruction** and technical advice to your projection personnel in the efficient operation of the equipment.
- 4 **Make periodic inspection** checkups . . . furnish replacement parts and tubes . . . supply emergency service—to forestall trouble, extend equipment life, keep repair costs down.

It costs so little to protect so much

And nowhere else do you get such *specialized* theatre TV service. Write for complete information.



RCA SERVICE COMPANY, INC.
A RADIO CORPORATION of AMERICA SUBSIDIARY
CAMDEN, NEW JERSEY

it is noted that the difficulty is principally in the red end of the spectrum. This is indeed fortunate since still background scenes rarely contain any significant red. Colors in such scenes are predominantly blue and green, where the comparison is not so odious. Nevertheless, this is not a satisfactory situation and it is hoped that new color films which will shortly be on the market will correct or at least improve this situation.

Although a picture is photographed on a two-dimensional medium (the film itself) and projected on another two-dimensional medium (the theater screen),



**THE PRACTICE OF
THROWING AWAY
CARBON STUBS IS
PROBABLY COSTING YOU
THOUSANDS OF DOLLARS**

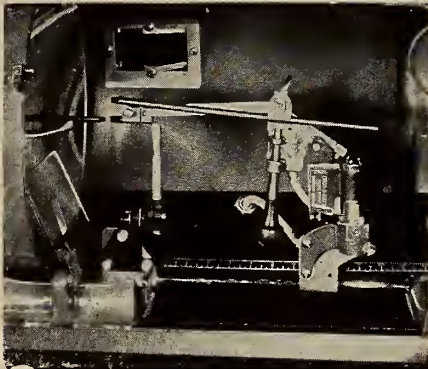

THE CRON-O-MATIC Fully Automatic CARBON SAVER

uses stubs of all lengths without any preparation. It's no longer necessary to guess whether or not a carbon stub will burn a full reel. No matter how short it may be, simply insert in the holder. When it is entirely consumed, the new carbon goes into use without losing the light. It in no way interferes with the regular operation of the lamp.

Adaptable to Ashcraft "D", Brenkert-Enarc, Peerless Magnarc and Strong Mogul lamps. Only \$52.50.

PAYS FOR ITSELF 3 TIMES A YEAR!

Burns positive carbon stubs, which usually average 3 1/4" in length, down to a constant length of 3/4", to result in a net saving of 2 1/2" per carbon or 22.2% of the cost of the carbon, which for the average theatre actually amounts to \$150.00 per month . . . every month!

If your dealer cannot supply you, order direct.

Dealer Inquiries Invited

PAYNE PRODUCTS CO. (Cron-O-Matic Division)

2454 W. Stadium Blvd. Ann Arbor, Mich.

- () Please send literature on the Cron-O-Matic
- () Please ship Cron-O-Matic Carbon Saver
- () C. O. D., including postage
- () Remittance herewith.

Name _____

Theatre _____

Street _____

City & State _____

EXPORT: Frazer & Hansen, Ltd.
San Francisco, New York, Los Angeles

the industry has always wanted a picture in three dimensions.

Three-Dimensional Films

There have been a number of papers presented with demonstrations of systems which permit of all three dimensions. Some of these have employed polarized light and others have obtained their separation by color, and similar procedures, but in every case they require the use of some kind of crutch by each individual in the audience, or they restrict the viewer's position and motion of his head in a most unnatural way. So far the industry has been unwilling to make any commercial use of any of these systems, except on a novelty basis.

The Research Council is constantly receiving proposals from inventors all over the world for systems to permit three-dimensional motion pictures. So far none of these systems appears practical. Nevertheless, each one is carefully considered and investigated if that seems necessary.

The Research Council activity in connection with color is largely confined to reporting to our member companies on various color systems as they are announced and studying problems of test and control for color systems which seem likely to receive commercial usage. We are consequently interested in color densitometers, color charts, printing machines and similar devices.

In the field of magnetic recording and in the older art of photographic recording, the Research Council has not been particularly active because both the studios and their suppliers are actively at work on these problems. An analysis of the economic problems which needed consideration in connection with mag-

netic recording was prepared, however, because the differences in operating practices and requirements throughout the industry were creating false impressions which needed correction.

Television Developments

Television presents another situation where the Research Council can only hope to keep abreast of that fast-changing art so that its member companies may be advised when television systems, equipment or techniques reach the place where they can be profitably applied to the production of motion pictures. In other words, the Council is not concerned with television as a medium of home



**You Can't Buy
A GOOD
Rectifier
for Less!**

Strong Rectifiers are the only rectifiers on the market which are especially designed, manufactured and tested in one plant together with and for use with motion picture projection arc lamps. This is highly important, as efficient operation of each type and rating of arc necessitates a rectifier specifically engineered to its particular requirements.

There is a dependable Strong Rectifier for every type projection lamp: 2-Tube • 4-Tube • 6-Tube • Single and Three Phase Models for

- Rotating Feed Angular Trim High Intensity
- Copper Coated Coaxial High Intensity
- 1 K.W. High Intensity
- Low Intensity

All assure smooth output current, long life, low operating temperature, and flexibility in control.

WRITE FOR LITERATURE OR FREE DEMONSTRATION

THE STRONG ELECTRIC CORP.
CITY PARK AVE. TOLEDO 2, OHIO
PROJECTION LAMPS
SPOTLIGHTS • RECTIFIERS • REFLECTORS

**USE ETHYLOID DOUBLE
ACTION FILM CEMENT
AND YOU USE THE BEST**

Made in U. S. A. by
Fisher Mfg. Co. 1/2 Salter Pl.
Manufacturing Chemists
Rochester 13, N. Y.

CLAYTON BALL-BEARING EVEN TENSION TAKE-UPS

For all projectors and sound equipments

All take-ups wind film on 2, 4 and 5 inch hub reels.
Silent Chain Drives

THE CLAYTON REWINDER

For perfect rewinding on 2000-foot reels.

CLAYTON PRODUCTS CO.

31-45 Tibbett Avenue New York 63, N. Y.

entertainment. It is concerned with it as a medium of theater entertainment and as a means of producing motion pictures.

There is oftentimes some confusion regarding the relationship of the Motion Picture Research Council to the Society of Motion Picture and Television Engineers. This misunderstanding usually arises from matters having to do with either standards activities or test films.

The Research Council works very closely with the Society on all problems of standardization within the motion picture industry, but as a member body of the American Standards Association the Research Council also acts directly on such problems. The Society and the Research Council work very closely together in the test-film field, each accepting orders for test films made by the other. Test films are looked upon as a service to the exhibition end of the industry which has been undertaken to insure satisfactory presentation of the studio product in the theater.

THE ELUSIVE SCREEN LUMEN

(Continued from page 8)

to raise the visible ray transmission to the screen) to equal that of a silvered glass reflector at 70-amperes (16,000 total screen lumens). By so doing we will have also increased the heat ray (infrared) transmission by 20% above that of a 70-ampere arc using a silvered glass reflector, thereby raising the light heat far above the safe heat level that film can stand.

Film Damage, Higher Cost

The net result of the foregoing hypothetical case is that though we have not increased the total amount of visible light (16,000 total screen lumens) that a glass reflector can produce at 70-amperes, we have, in addition to making film heat damage inevitable, increased the 70-ampere current and carbon operating costs about 50%.

Thus, it is perfectly clear that without some means of light-heat protection being afforded to the film, the mere use of a certain type or size of carbon combination, having a claimed high maximum screen lumen output, at a certain amperage, in a lamp having a particular diameter reflector and certain high *F* light beam speed, is absolutely no guarantee that a higher level than 16,000 total

visible screen lumens will be obtained therefrom, because were it actually possible, film damage would positively follow.

We feel strongly that a sales organization or manufacturer who claims or intentionally creates the impression that levels of screen illumination of from 18,000 to 26,000 total screen lumens are possible, and at the same time intentionally avoids mentioning any light reductions because of the absolute need of light-heat protection for the film, or who gives the wholly erroneous impression

that such supplementary protective means are not necessary, should be forced to prove his contention.

Such proof might take the form of (1) a guarantee that such high total screen lumens could and would be continuously maintained, and (2) guarantee payment to the purchaser for all film damaged by such an operation.

Comparative Summary of Systems

HEAT-ABSORPTION GLASS: Original cost is exceedingly low as compared with any other. No high installation cost. Upkeep

NOW!

**REPLACE
WORN SPEAKERS
WITH
STURDY, DURABLE
SPEAKER UNITS!**

**HIGH QUALITY
3½" and 4"
P.M. SPEAKERS**

*Ask Your
National Salesman*

**NATIONAL
THEATRE SUPPLY**
Division of National • Simplex • Bludworth, Inc.

NOW'S THE TIME!... The time to replace car speakers battered through months of hard wear with dependable, weatherproof Speaker Units. Don't delay! Place your order today while stocks are still available.

**NEVER HAS
Economy
BEEN SO
ESSENTIAL AS NOW!**

**SLOW BURNING
SAVINGS IN POWER CONSUMPTION
SAVINGS IN MAINTENANCE**

**ECONOMIZE
WITH *Lorraine
Carbons***

Lorraine CARBONS, INC., BOONTON, N. J.

THERE IS A LORRAINE CARBON TAILORED FOR YOUR SPECIFIC PROJECTION REQUIREMENT

Send necessary projection equipment data to guide us in recommending the Lorraine Carbons that will do your theatre or drive-in projection job better and More Economically.

REEL-END ALARMS

Jackson's Patd. Automatic!

Can't Scratch Film! Foolproof!
Lasts a Lifetime! \$18.50 per pair
On Money Back Guarantee

Order one from your dealer or write to
American Theatre Supply Co., Inc.
2300 First Ave., Seattle 1, Wash.

and operational cost is practically nothing by comparison with other systems. It offers a selective cooling feature which permits only the required degree of cooling as is needed to prevent heat damage to the film. Positively and definitely effective.

HEAT-REFLECTION (DICHROIC): At the present not as efficient and not sufficiently developed for a fair comparison with other systems.

MECHANISM WATER-COOLING: Completely ineffective as a means to reduce the thermal impact (light heat) of the light striking the film.

HIGH-VELOCITY APERTURE AIR JET: As presently applied to regulation projection service, it can not be expected to function as a definite method of affording absolute light-heat protection to the film.

An elementary example conclusively illustrating the ineffectiveness of air-stream systems to reduce the thermal impact of the light upon the film is the fact that, though the winter sun's rays pass through untold miles of sub-zero space and winds, yet when they are stopped here on earth, they still contain their proportionate amount of thermal content (heat) and radiant energy (visible light).

This proves a basic tenet of physics, that the mere passing of a high-velocity air stream through any beam of light will in no way alter the originally generated proportions of its thermal energy (heat) to its visible radiant energy (light). Hence, such systems can only be expected to dissipate accumulated heat *after* it has been absorbed and built up in the film.

It is difficult, therefore, to justify its high initial cost, high installation cost, high operational and maintenance expense as compared with that of the heat-absorbing glass system.

Where Do We Go From Here?

As has been clearly shown, our industry now has projector arclamps—8-mm copper-coated carbons at 70 amperes—which produce all of the light that film can stand (up to 16,000 total screen lumens) without the use of heat-filtering devices. Also, we have lamps—13-mm carbons at 180 amperes—that produce a sufficiently higher volume of light (to 26,000 total screen lumens) so that a major increase in screen illumination is possible *with* heat-filtering devices.

Of the utmost pertinency at this point is the fact that due to the mechanics of present-day projectors, their optics and accepted projection practice, only from 20 to 35% of the total visible light produced by any type of 35-mm arclamp ever reaches the screen. The normal light waste, therefore, is inversely from 186 to 400%.

It's an astounding fact, but we waste

from three to four times more light than we actually use for projection to the screen!

Thus, we already have one lamp producing all the light (heat) that film can tolerate, and another that produces almost 100% more light (heat) than film can tolerate, and we have the situation of a tremendous light loss as a result of projector construction and projection practice. In the face of these facts, it is pertinent to ask just where the so-called intermediate type of lamps—9-mm carbons at 85 amperes—fit into the picture. What advantage do they offer except high first cost and continuing higher operational and maintenance cost?

New Carbons, Lamps No Answer

Just how can new carbon combinations, requiring higher amperage, voltage and new lamps, be expected to provide higher screen illumination if they do not exceed by a worthwhile margin the high levels of total light that we now can produce?

It seems to us that the logical solution to the problem of obtaining higher screen illumination levels lies primarily in salvaging some of the vast amount of light we now waste, through the adoption of more efficient optics, revolving shutter arrangements and intermittents. After all, it makes small difference if in ruining film we do it by warping and blistering it by heat or by accelerating the rate of sprocket hole wear.

Another question: *who* should determine just how much more visible light and light-heat can be tolerated by nitrate, acetate or any other type of film stock?

Where do we go from here for higher screen illumination? Well, in the face of all the aforementioned facts, we are certain that the answer will not be found in new carbon combinations requiring new lamps and new power supply units. This course will only result in higher initial and operating costs for the exhibitor, and for the manufacturer the extra burden of tooling for and producing such equipment.

It's all right to dream, but we have to wake up before we can make our dreams come true.

New Film Prints From Old

Making new prints from shrunken, older motion picture films will be less of a problem through use of a new variable-pitch sprocket developed by Kodak. J. G. Streiffert, Kodak scientist, reported on the new sprocket at the recent SMPTE convention.

The device has a unique sprocket tooth whose driving face is a plane lying on a radius of the sprocket. This is used to improve longitudinal registration of the film over that obtained with conventionally-shaped, curved-profile teeth. The sprocket, with a supporting drum, accommodates shrinkage through varying pitch. Streiffert reported that flutter in sound prints and steadiness in picture prints made on a sprocket of this type in a 16-mm printer were found to be substantially independent of film shrinkage and markedly better than in prints made on conventional printers.

How Many?

Was this copy dog-eared when it came to you? How many men read it ahead of you?

You would receive a clean, fresh copy if you had a personal subscription—and you wouldn't have to wait—you would be first to read it.

Use coupon below.

INTERNATIONAL PROJECTIONIST.

19 West 44 St., New York 18, N. Y.

Enter my subscription for

1 year—12 issues—\$2.50

2 years—24 issues—\$4.00

Foreign and Canada: Add 50c per year.

Name

Address

City State

How Old is Santa Claus?



This particular
Santa—the one
you see on the
Christmas Seals—
is a very healthy forty-five!

Yes, this is the 45th annual
Christmas Seal Sale—a holiday
custom that has made possible one
of the great social, economic,
and medical achievements of the present century.

Your purchase of Christmas Seals has helped save
5,000,000 lives. Yet, tuberculosis kills more people
than all other infectious diseases combined.

So, please answer once again the call that comes but
once a year—and help make possible the campaign
against tuberculosis every day of the year.



Because of the impor-
tance of the above
message, this space has
been contributed by

Buy Christmas Seals!

INTERNATIONAL PROJECTIONIST

it's
MOVIETIME
U. S. A.

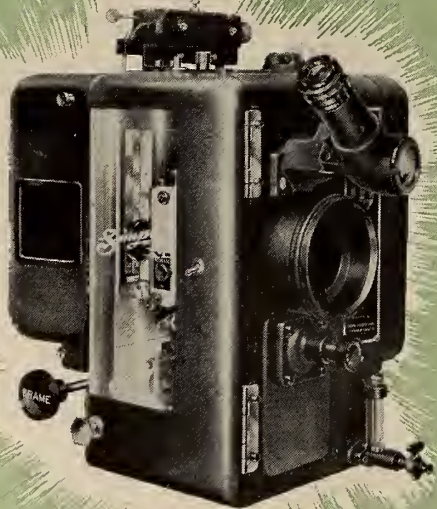

Are You Prepared?

BETTER PICTURES
DESERVE
BETTER PROJECTION

Your patrons deserve only the finest! And there is none finer, none more reliable than the SIMPLEX X-L! For the makers of SIMPLEX projection and sound systems have behind them the vital know-how needed to produce the best!

- Forty years of faith in the motion picture industry.
- Forty years of advanced design experience.
- Forty years of constant development and improvement.
- Forty years of proven dependability and proven performance in motion picture theatres all over the world.

Give your patrons the finest—give them SIMPLEX X-L projection.

Simplex
T. M. REG. U. S. PAT. OFF.

X • L

**PROJECTION AND
SOUND SYSTEMS**

PROJECTIONIST

INTERNATIONAL

B 332930



DECEMBER 1951

VOLUME 26 • NUMBER 12

30c A COPY • \$2.50 A YEAR



BUY CHRISTMAS SEALS
FIGHT TUBERCULOSIS

Peerless
MAGNARC

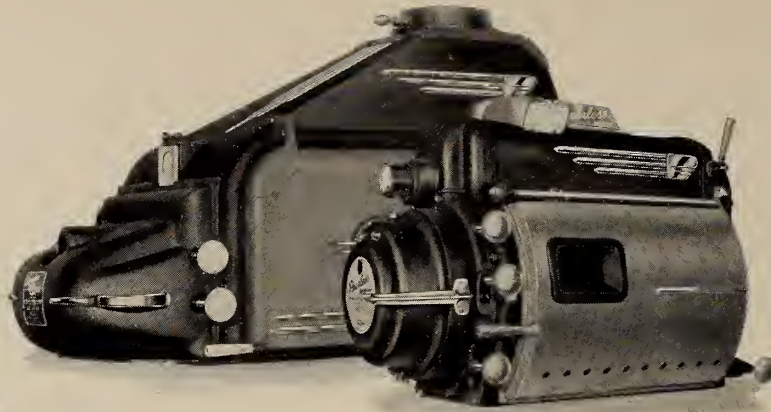

Peerless
INCANDESCENT
TRADE MARK REG.

"The finest Arc Lamps ever made"

To you CRAFTSMEN —

Merry Christmas!

and for the NEW YEAR

Continued Prosperity!



J. E. McAULEY MFG. CO.

552-554 WEST ADAMS STREET
CHICAGO 6, ILLINOIS

Season's Greetings



International Alliance of Theatrical Stage
Employes and Moving Picture Machine
Operators of the United States and Canada

Affiliated with the A. F. of L.

RICHARD F. WALSH

*International
President*

WILLIAM P. RAOUL

*General
Secretary-Treasurer*

THOMAS J. SHEA

Assistant International President



Greetings for Christmas
and Best Wishes for
Prosperity and Security for 1952

from

CHICAGO LOCAL UNION NO. 110
I. A. T. S. E. & M. P. M. O.

EUGENE J. ATKINSON

Business Representative



INTERNATIONAL PROJECTIONIST

With Which Is Combined PROJECTION ENGINEERING



HENRY B. SELLWOOD, *Editor*

Volume 26

DECEMBER 1951

Number 12

Index and Monthly Chat	5	In the Spotlight	28
Projectionist's Role as a Showman	7	HARRY SHERMAN	
ROBERT A. MITCHELL		Eidophor Theater Tv System: Some Pertinent Questions	31
Movie Studio Carbon Arc Lighting	11	Depth of Focus—Again	32
HENRY B. SELLWOOD		'Fuzzy Frames' in Color Prints	33
The Allied Arts & Sciences	17	ROBERT A. MITCHELL	
IV. Photographic Optics		NPA Conservation Appeal	34
BAUSCH & LOMB OPTICAL CO.		Movies Out of Doghouse	35
The G P L 'Simplex' Direct-Projection Theater Tv System	22	IA Elections	37
F. N. GILLETTE		Friese-Greene a Legend	39
Who Invented the Movies?	27	TERRY RAMSAYE	
GERALD PRATLEY		News Notes	
		Technical Hints	
		Miscellaneous Items	

Published Monthly by

INTERNATIONAL PROJECTIONIST PUBLISHING CO., INC.

19 West 44 Street, New York 18, N. Y.

Telephone: MURRAY HILL 2-2948

R. A. ENTRACHT, Publisher

SUBSCRIPTION REPRESENTATIVES

AUSTRALIA: McGills, 183 Elizabeth St., Melbourne

NEW ZEALAND: Te Aro Book Depot, Ltd., 64 Courtenay Place, Wellington

ENGLAND and DOMINIONS: Wm. Dawson & Sons, Ltd., Macklin St., London, W. C. 2

YEARLY SUBSCRIPTION: United States and possessions, \$2.50 (two years, \$4); Canada and foreign countries, \$3; single copies, 30 cents. Changes of address should be submitted two weeks in advance of publication date to insure receipt of current issue. Entered as second class matter February 8, 1932, at the Post Office at New York, N. Y., under the act of March 3, 1879. Entire contents copyrighted 1951 by International Projectionist Publishing Co., Inc. INTERNATIONAL PROJECTIONIST is not responsible for personal opinions appearing in signed articles in its columns.



MONTHLY CHAT

COMES now the turn of a year which crushes in a period during which the motion picture industry, and particularly the exhibition end, will have to make decisions which could well determine whether the industry will continue to exist as we have known it for these many years. Production and distribution will also be mightily affected by the turn of events within the next twelve months, but their problems are picayune by comparison with those which face the exhibition end.

Time was when this industry we so loosely termed "the picture business" operated under one big tent, so to speak. But, alas, no more: the canvas has been rent and well-nigh ripped to tatters by many forms of competition for the leisure time and amusement dollar of the populace.

Home television is rated the No. 1 competitor of the movie theater. But there are many others: straightaway radio shows, gin rummy, bridge, parlor tipping, etc., which have zoomed the stay-at-home total. Collectively this is tough competition, of course, but it is remarkable how these competitive forces are dispersed when a really good movie hits the theater screen.

Admittedly not all movies released to theaters rate an A-1 classification. Neither do the majority of radio shows, despite top writing, directorial and acting talent. As for home Tv today, it is no exaggeration to say that 90% of its output is outright trash. Yet home Tv continues to hold and to *build* its audience. The significance of this fact to us is that the movie industry is standing still technologically and is doing nothing to resist Tv's inroads on its business, much less to *regain* its lost customers.

This old refrain has been sung in this space on many occasions. But unless drastic changes are effected in the taking and showing of motion pictures within the next 12 months, we think that some 75% of movie theaters will have so few customers as to make their operation not only unprofitable but prohibitive.

What to do? Why, just take some of these terrifically inflated star (?) and executive (?) salaries, plus other monetary fowler, and plough it back into the erection of a solid technological foundation—as did the smart radio and Tv boys. We repeat: vastly improved color, truly stereophonic sound reproduction, and, yes, an approximation at least of three-dimensional movies are available for a tithe of the money that is now being poured down the drain on the superfluous fringe of the industry.

Failing to take these positive steps forward, 1952 may well prove not a milestone but a tombstone for a majority of movie theaters.

Glum words, these, but we have an idea that, lacking forthright and vigorous action, they will prove to be prophetic—and with a vengeance.

On movie sets...

**BETTER
MOVIES!**

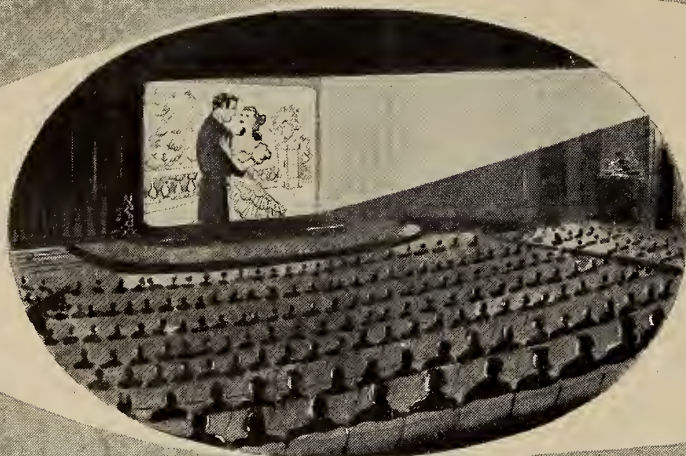

In movie houses...

**BIGGER
BOX OFFICE!**

THE NATIONAL TRADE-MARK **CARBON ARCS** **BIG 5** Pays off!

The "National" carbon arc offers advantages — in making movies in the studio . . . in projecting movies in theatres — *that no other light source can match:*

- **SMALL SOURCE SIZE**
- **HIGH BRIGHTNESS**
- **GREAT POWER FROM ONE UNIT**
- **WHITE LIGHT**
- **MINIMUM HEAT PER FOOT CANDLE**

This "Big 5" offered by the "National" carbon arc means movies of highest technical lighting quality. Shadows are sharp and dramatic. Depth of focus is excellent. Heat on the actors is at a minimum. And, when you use the "National" carbon arc in your projection booth, the picture is at its best. You gain in quality all along the line.

**YOU CAN'T SKIMP ON STUDIO LIGHTING
WITHOUT RISKING BOX OFFICE!**



When you order studio or projector carbons — order "National"!

The term "National" is a registered trade-mark of Union Carbide and Carbon Corporation

NATIONAL CARBON COMPANY
A Division of Union Carbide and Carbon Corporation
30 East 42nd Street, New York 17, N. Y.

District Sales Offices: Atlanta, Chicago, Dallas, Kansas City, New York, Pittsburgh, San Francisco

IN CANADA: National Carbon Limited
Montreal, Toronto, Winnipeg



Projectionist's Role as a Showman

MOST theaters have footlights and two curtains—grand drape and title curtain—which can be controlled from the projection room. When the footlights are split up into two or more separate circuits, each circuit controlling bulbs of one color, a real opportunity is provided for “dressing up” the openings. If the stage is also equipped with overhead striplights operated from dimmers, the projectionist can “go to town” with openings and intermissions.

Facilities for controlling auditorium and stage lighting vary. The worst possible setup, from the standpoint of showmanship, is the theater which lacks curtains, footlights, and a dimmer for the houselights: the projectionist must start the show “with a bang,” flashing the picture on the bare screen at the same instant the houselights are turned off—the nickelodeon-style opening. With more elaborate arrangements, the projectionist must have his routine worked out to avoid a clumsy opening.

For an Effective Opening

The projectionist should study the situation carefully and “dream up” an effective opening. A bit of experimenting will pay rich dividends. In general, the routine is as follows in a theater equipped with non-sync, two curtains, footlights, and houselights dimmer:

1. Non-sync playing music appropriate to the screen attraction. Both curtains closed, houselights and footlights on.
2. Film in the “first” projector run down a few inches past the “3” frame of the leader. Changeover shutter open, sound fader off, or switched over to the “second” projector.
3. Sound amplifier will be operating, of

By **ROBERT A. MITCHELL**

Second in a series of articles which detail helpful technical hints anent the preparation for and projection of a good theater motion picture show.

course; but if there is no non-sync, the amplifier will be turned on a few minutes before the opening.

4. Arc generator or rectifier turned on about 4 minutes before the opening. Arc of “first” projector struck and allowed to “burn in” for 3 minutes if low-intensity, 1 minute if high-intensity, before starting time.
5. **STARTING TIME.** The grand drape is now opened, and the houselights are slowly dimmed and extinguished. (The auditorium is not in darkness, for the footlights gleam on the title curtain, focusing attention upon the stage.)
6. Projector started, lamphouse douser opened to flash the title on the curtain.
7. *Immediately* the title curtain is opened, sound faded from non-sync to projector, and footlights turned off. The show is now underway.

Variations of Procedure

A number of variations of this 7-step procedure will at once suggest themselves. For example, in some theaters the arrangement of sound faders may make it desirable to turn off the footlights *before* changing from non-sync to sound-on-film. In other theaters, it may be best to have the fader set to the incoming projector—it depends entirely upon local conditions and the way the sound wiring is hooked up.

Clumsy hookups outnumber the convenient ones, thus requiring quite a bit of hopping around by the projectionist. Intolerably clumsy hookups should be corrected, even if local electricians and the sound serviceman have to be called in to advise and assist with the changes.

Also, the places in the aforementioned procedure where speed is advisable will be apparent. Overall, however, the process is a leisurely one, but with no standstill at any time. *Something* must be “happening” all the time—a curtain opening, or lights dimming, *etc.* For this reason, the incoming projector should be started up when the grand drape is about halfway open. By the time it has opened nearly all the way, the picture may be flashed onto the title curtain by opening the lamphouse douser.

On the other hand, to open both curtains, flash the picture on, and turn off all lights simultaneously is too hurried a technique to be good showmanship. If you have all the facilities for an impressive opening, get the most good out of them.

Although real showmanship avoids unnecessary flourishes, the addition of a colored spotlight effect on the curtains sometimes helps when there is only one footlight circuit, or no footlights at all. After a definitely pleasing opening routine has been worked out, it should be rehearsed until it can be performed perfectly.

Projection of Titles, Credits

Much debated is the running of *all* the “titles” of a film—credit captions included—on the title curtain, not opening this curtain until the first scene of the picture appears. Some projection-

ists believe that this practice contributes additional "dress" to the performance; others hold that audiences prefer to see the titles on the screen instead of wording more or less garbled by the folds and colored designs of a curtain. A somewhat similar matter of debate is color-flooding the titles of each new subject by means of colored footlights, strip-lights, etc.

Extreme points of view are advocated by the "fundamentalists" and the "esthetes" of the projection brotherhood. The former would dispense with all frills, once a show is in progress, and make changeovers from subject to subject without using the title curtain or any lighting effects; they prefer to avoid all "fancy tricks" and run their shows straight. The esthetes, on the other hand, are the poets of the craft. They never miss an opportunity to "shoot the works," even to the extent of momentarily shutting down the projectors between film-subjects while curtains open and close to the accompaniment of vari-colored lights.

There is something to be said for both viewpoints. Each has its advantages and disadvantages. This suggests a middle path to be followed in the average theater, a path which permits considerable flexibility of presentation technique.

Middle Course Advocated

For the average theater the "straight run" is too "commercial" and impersonal; while overly complicated bedazzlements inserted in the show are likely to exhaust the patience of suburban audiences and cause steady patrons to poke fun at the bombastic goings-on. A happy medium must be found; and the safest rule that the writer can think of is this:

Any presentation technique which irritates and annoys the "kids" who attend a particular theater is somewhat too complex to be suitable for that theater. A child's *intuitive* tastes are far superior to an adult's *acquired* tastes. And a kid offers his opinions freely and frankly.

The middle path would therefore appear to consist of an impressive opening of the show and a minimum of interruption during its progress. Superfluous interposition of curtains should be eliminated, and color-flooding of titles avoided for the most part. (The titles of natural-color films should *never* be color-flooded!) Likewise, decorative lighting on or near the stage should be reserved for openings and intermissions and not allowed to distract the attention of patrons while a picture is being shown.

The title curtain, being made of light-colored material, should be closed and *immediately* opened again between subjects; but the footlight and striplights should not be used except on special occasions when color-flooding is deemed

desirable. Special color effects are best reserved for the showing of trailers, most of which can well stand a little dressing up these days in the absence of tinting and toning thereon.

Deficiencies of Trailers

Some of the trailers we receive these days are unfit for showing in a first-class theater. "Open," "close," and date strips are of poor quality, carelessly made and evidently the product of innumerable re-printings. They jump and rock on the screen, are "fuzzy" in image definition, contain black or incomplete frames, and are not long enough or furnished in sufficient quantity enable the projectionist to abandon splicing parts of two or three of them together. The evil of mid-frame splices is also directly attributable to insufficient supplies of date-strip films.

Theater managements are urged to consider the use of "tailor-made" film strips which are tastefully and beautifully designed and which include the name of the theater in the "open" and "close" coming-attraction strips. A large number of companies specializing in trailer material can make "titles" at low cost, even when animated lettering is desired. This is a matter worth investigating, as the use of inferior title strips is not good showmanship.

Lighting the Stage Show

Stage entertainment, be it a mere "cash night" conducted from the stage or an elaborate vaudeville bill, calls for real showmanship on the part of the projectionist if spotlight operation and manipulation of stage lighting are included in his duties. He should learn beforehand exactly what is expected of him, study his cue-sheet carefully, and give considerable thought to producing a professionally smooth transition from movies to stage. Necessary adjustments in the spotlight should be made before the show, and, as a rule, the spotlight ought to be set up for the first "effect" re-

quired, as regards the size of the spot, the color, and position on the stage.

When the "performance" is nothing more complicated than the manager or master-of-ceremonies appearing on the stage to give an announcement or to conduct an audience-participation program of some sort, have the spot directed at the left-hand end of the stage where the master-of-ceremonies will first appear; then "follow" him to the center of the stage. This seems much better than forcing him to "walk into" a spot directed first to the center of the stage.

In such cases the spot should be just a little larger than is necessary to include the master-of-ceremonies' whole figure. It should be remembered that when someone appears on the stage, the audience wishes to get a good look at him from head to toes. If he introduces another speaker, the spot should be enlarged momentarily, and not reduced until the new speaker is alone on the stage.

Spotlight Colors Important

If a singer or instrumentalist is introduced, white foot- and strip-lights should be turned on, and the widened spot colored pink or amber, the latter color being preferable when the performer is male. Then when the performer "goes into his act," the spot should be turned back to white, reduced in size, and the footlights changed to a suitable color. (Green and blue are colors which should be avoided when using the spotlight on a single person, as these two hues discolor the complexion, even when makeup is used. Special "acts" may call for any color of spot, however.)

When a motion picture program is in progress there is always the possibility, however slight, that something may go wrong. With equipment properly maintained and prints adequately repaired, this possibility need cause no concern; but it exists nevertheless. Perhaps the

(Continued on page 42)

INTERNATIONAL PROJECTIONIST

extends to all its friends

the

Season's Greetings

Now...

UNIFORM LIGHT

← FROM CENTER TO SIDES →

with this exclusive

RCA EVENLITE

PATENTED

SCREEN

HERE'S HOW

These graded perforations taper from full size in center area to no perforations in side areas. Compensate for "hot-spot" effect of projected light.

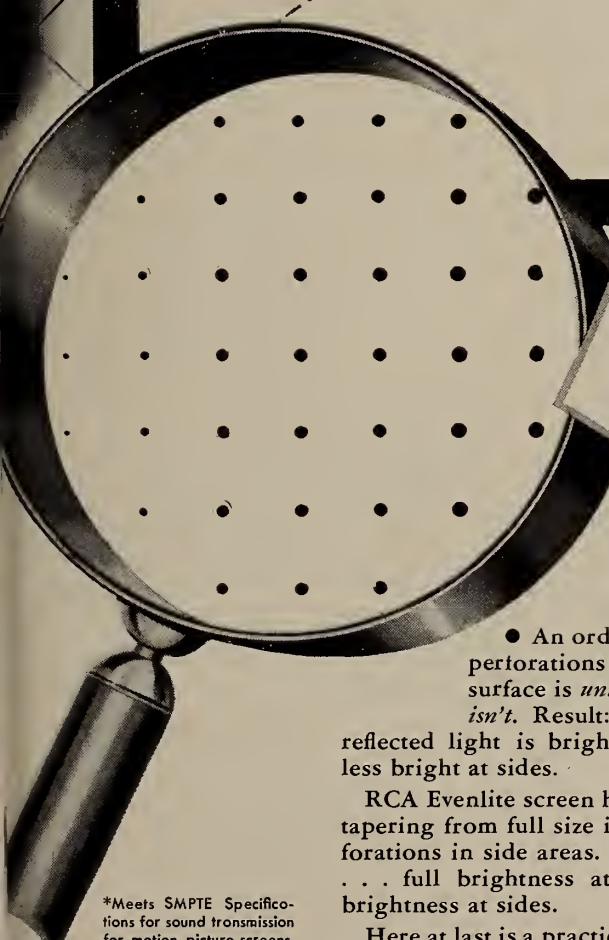

● An ordinary screen has *uniform* perforations across entire face. Screen surface is *uniform* but projected light *isn't*. Result: "hot-spot" effect . . . reflected light is brighter at center of screen, less bright at sides.

RCA Evenlite screen has varying perforations, tapering from full size in center area to no perforations in side areas. Result: *uniform* lighting . . . full brightness at center of screen, full brightness at sides.

Here at last is a practical solution to the screen light distribution problem . . . a screen that actually compensates for non-uniform light projected from an arc lamp. At center, where perforations are maximum, hole size *does not exceed*

**eight per cent*. So Evenlite gives you as much light at center as any standard-perforation screen. At sides, where perforations are zero, Evenlite gives you at least *eight per cent more light*, out on the dim edges where every bit of light is needed. And these unperforated side areas are *big!* On larger screens, from 50 to 75% of area *has no perforations!* All this *extra* screen light, with no loss in sound quality.

Look into RCA Evenlite now. It *costs no more* than ordinary screens, yet gives you a uniformity of lighting never before possible. Made of long-lasting, high-reflecting RCA Snowwhite Heavy-weight Vinyl Plastic. Exclusive with RCA. Available immediately . . . so call your RCA Dealer for full details . . . *today!*

*Meets SMPTE Specifications for sound transmission for motion picture screens.



THEATRE EQUIPMENT

RADIO CORPORATION of AMERICA

ENGINEERING PRODUCTS DEPARTMENT, CAMDEN, N.J.

In Canada: RCA VICTOR Company Limited, Montreal

IT'S REALLY

UP THERE

when it comes to projecting
BIG, BRIGHT pictures!

NATIONAL EXCELITE PROJECTION ARC LAMP

For super-brilliant pictures on large screens AT LOWER OPERATING COST, buy this 75 to 130 ampere high intensity reflector type lamp.

- ★ Air-cooled rotating positive carbon feeding mechanism.
- ★ Big 16½" reflector matches high speed f/1.9 lens.
- ★ Automatic arc crater positioning.
- ★ Stable burning and complete combustion at the arc, to avoid any black soot, are attained by a jet of air directed just above the arc.
- ★ White smoke, which would otherwise cloud the mirror, is also diverted by this air stream.
- ★ Unit construction permits instant removal of components for cleaning.

Distributed by

NATIONAL
THEATRE SUPPLY

Division of National - Simplex - Bludworth, Inc.

"THERE'S A BRANCH NEAR YOU"

TABLE 1. Characteristics of Carbon Arc and Incandescent Tungsten Studio Lamps

Lamp	Light Source	Fresnel Lens Diam.	Beam Spread		Apparent Candle Power at Center of Beam	Beam Lumens*	Approximate Apparent Source Size-Inches**		
			For 10% of Center Intensity	For 50% of Center Intensity			Visual	Photometric	
Carbon Arc Lamps									
Type 450 "Brute"	225 amp. 16mm Carbon	24"	Minimum Spot Flood	12° 48	5° 35	10,000,000 1,000,000	117,000 260,000	23.5 4.1	13.3 3.4
Type 170	150 amp. 16mm Carbon	20"	Minimum Spot Flood	10 48	4.4 42	5,700,000 300,000	47,000 130,000	19.5 1.8	9.7 1.2
Incandescent Tungsten Lamps									
Type 414 "Senior"	5KW bulb	14	Minimum Spot Flood	13 45	8 36	1,050,000 120,000	18,000 37,500	13.3 3.6	8.3 3.0
Type 410 "Junior"	2KW bulb	10	Minimum Spot Flood	12 44	8 39	420,000 40,000	6,900 14,000	9.0 2.8	5.7 2.2

*Boundary Intensity 10% of center intensity.

**Horizontal dimension as viewed visually and as measured photometrically from the beam through the Fresnel lens.

Movie Studio Carbon Arc Lighting

Small Source Size, High Brightness and High Unit Power in Producing Daylight-Quality Light Render it Superior in Penetration and Area Coverage, and in Shadow Sharpness.

CARBON arcs have been for many years the dominant studio light source for motion picture photography. They are used extensively in black-and-white photography, and until very recently, at least, they were practically the sole light source for Technicolor and other 35-mm three-color processes. The widespread industry interest generated by Technicolor's recent development of a more sensitive negative film combination intended for use with light of 3350 K. color quality, suggests another look-see into the technical aspects of carbon arc

By HENRY B. SELLWOOD

as contrasted with incandescent ("inkie") lighting.

Studio light sources have a direct relation to theater projection in terms of the old adage: "If picture quality isn't on the film, one can't put it on the screen."

Basis for this discussion are the arc and incandescent spotlamps shown in Table 1. The optical system used with carbon arcs is shown in Fig. 1. The incandescent lamp optical system differs

only in the addition of a spherical mirror positioned behind the light source to gather otherwise lost radiation and direct it back through the source and into the useful beam.

Carbon Arc Optical System

The carbon arc optical system affords a wide range of beam spreads from 10-13° at minimum spot to 44-48° at full flood. Total lumens in the beam at various beam spreads are shown in Table 1. At full flood the closer spacing of the lens from the light source gives a greater pickup of light than at minimum spot.

At a single beam spread, the light intensity varies approximately as the inverse square of the distance from the lamp. It is thus possible to assign for each beam spread an apparent candlepower value which can be divided by the square of the distance to obtain the intensity at any distance. Data bearing on this point, as compiled by Mole-Richardson Co.,* are given in Table 1. The greater concentration of the beam at minimum spot more than offsets the smaller light collection, and results in greater beam candlepower than at wider beam spreads.

The color quality of the light source is a paramount consideration in motion picture photography.** This quality in a high-intensity carbon arc makes it suitable directly or with only minor filtering

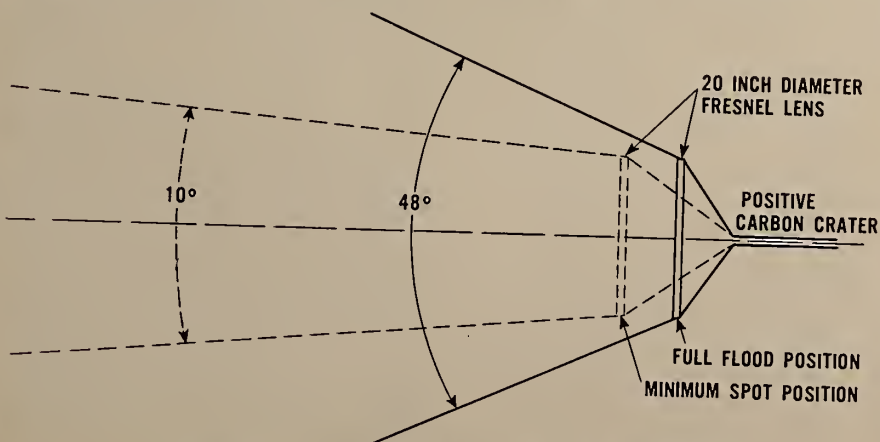

FIGURE 1. Optical system of the Type 170 lamp.

* Arclamp manufacturer, Hollywood, Calif.

** See "Color Temperature: Origin and Meaning," by W. W. Lozier; IP for Nov. 1947, p. 5.

TABLE 2. Lamp Performance for Equivalent Photographic Effect at the Center of the Beam with Various Types of Color Film

Lamp	Beam Spread	Projection Distance — Feet				Range of Projection Distance for ±20% Variation of Light Intensity				Beam Diameter*** — Feet				Apparent Angle Subtended by Light Source — Degrees****			
		150 Foot-300 Foot-		450 Foot-450 Foot-		150 Foot-300 Foot-		450 Foot-450 Foot-		150 Foot-300 Foot-		450 Foot-450 Foot-		150 Foot-300 Foot-		450 Foot-450 Foot-	
		Candle Film	Daylight Film	Candle Film	Daylight Film	Candle Film	Daylight Film	Candle Film	Daylight Film	Candle Film	Daylight Film	Candle Film	Daylight Film	Candle Film	Daylight Film	Candle Film	Daylight Film
Carbon Arc Lamp																	
Type 450 "Brute"	Minimum Spot Flood	182 58	173 55	141 45	36.4 11.6	34.6 11.0	28.2 9.0	38.3 (15.9) 51.3 (36.6)	36.4 (15.1) 49.0 (34.7)	29.7 (12.3) 39.8 (28.2)	.35 .28	.37 .30	.45 .36				
Type 170	Minimum Spot Flood	138 32	131 30	107 24	27.6 6.4	26.2 6.0	21.4 4.9	24.2 (10.6) 28.2 (24.4)	22.9 (10.1) 26.7 (23.0)	18.7 (8.2) 21.7 (18.7)	.34 .18	.35 .17	.43 .24				
Incandescent Tungsten Lamps																	
Type 414 "Senior"	Minimum Spot Flood	84 28	37 13	31 10	16.7 5.6	7.5 2.5	6.1 2.0	19.1 (11.7) 23.4 (18.4)	8.5 (5.3) 10.5 (8.3)	7.0 (4.3) 8.5 (6.7)	.47 .51	1.06 1.13	1.30 1.39				
Type 410 "Junior"	Minimum Spot Flood	53 16	24 7	19 6	10.6 3.2	4.7 1.4	3.8 1.2	11.2 (7.4) 13.2 (11.5)	5.0 (3.3) 5.9 (5.2)	4.1 (2.7) 4.8 (4.3)	.51 .64	1.15 1.44	1.41 1.75				

*Types 450 and 170 with filter of 50% transmission; Types 414 and 410 unfiltered.

**Types 450 and 170 with filter of 90% transmission; Type 414 and 410 with filter of 40% transmission.

***Values in parentheses are for boundary intensity of 50% of center; others are for boundary intensity 10% of center.

****The sun subtends an angle of 0.5 degrees; sources smaller than this will produce sharper shadows and those larger will produce fuzzier shadows.

when shooting with color film balanced for daylight. With film balanced for lower color temperatures, more red than green, and more green than blue, light is required, thus a white light source when used with such film must have a substantial portion of its blue and green content removed.

As an example, with a black body at 3350° K., the blue content is exceeded by the green content by about twice, and by the red content about three times. Matching this radiation with a white light source, or one with approximately equal energy at all wavelengths, requires filtering of an order which will diminish by at least two-thirds the blue content and by one-third the green radiation inherent in the light source. This filtering represents a theoretical light loss of about one-third.

With color films definitely on the upswing, the following summary of the present state of the art relative to particular types of color film should prove of interest.

1. 150 Foot-Candle Film Balanced for 3350° K.

As a complementary to this discussion, the assumption here is that a deep amber filter of about 50% foot-candle transmission will serve to utilize carbon arc light for this type of film. The type of gelatin filter combination now being used with Technicolor film of this type matches these characteristics; however, a much higher degree of light transmission is quite possible, as aforementioned. Also directly suitable for this are inks of the proper color temperature.

2. 300 Foot-Candle Film Balanced for Daylight

Present studio practice, based on extensive tests, indicate that a light yellow Y-1 filter effecting 90% light transmission will enable the use of carbon arc lamps with this film. By way of contrast, incandescent lamps of 3350° K. color temperature must utilize deep blue filters having only about a 40% light transmission value.

3. 450 Foot-Candle Film Balanced for Daylight

Penetrating power, which makes possible the projection of useful light intensities from great distances with a single lamp, has long been an outstanding advantage of the studio carbon arc studio lighting. Projectionists well understand that, with a given lamp setting, the inverse square law dictates that the light decrease rapidly with increasing distance.

Now, it follows that if a lamp be placed close to a set having any appreciable depth, the ensuing light intensity will vary en route across the set. There is only one answer to this problem—a light source with enough penetrating power to

permit its positioning farther away from the set so that set depth becomes a *smaller fraction* of the projection throw.

This penetrating power (projection throw) of the different lamps for the same photographic effect at the center of the beam is indicated in Table 2. These data show the distances at which the lamps considered, with proper filtering, will project 150, 300, and 450 foot-candles of light intensity for the three types of film mentioned previously.

Intensities at Given Throw

Now we come to the crux of this presentation. Table 2 shows that with the beam spread adjusted for minimum spot, the indicated intensities will be projected about three times as far as when the lamp is set for full flood. We see here that at minimum spot the most powerful carbon arc will project the indicated intensities more than 180 feet for the 150 foot-candle film, and more than 170 feet for the 300 foot-candle film.

By way of contrast, it will be noted the most powerful inkie tungsten lamp (the "Senior") is much lower in penetrating power than the most commonly used arc-lamp, the Type 170, when used with the 3350° K. type film. Where the carbon arc and the inkie emphatically part company, to the distinct advantage of the former, is with the use of the 300 and the 450 foot-candle daylight film, by reason of the more favorable filter factors. In this category none of the inkie lamps even approach the light output of *any* of the carbon arcs.

Table 2 also shows the requisites for coverage of depth of set—that is, the range of projection distance which can be effectively lighted within plus or minus 20% of the specified light intensity in a given case. It is seen that the more powerful carbon arc lamps and the small beam spreads are required to achieve this degree of light uniformity on sets deeper than 25 feet. It is always possible, of course, to use a number of lesser-intensity units at the same distance to attain the equivalent light uniformity across the set; but this procedure might sometimes result in undesirable multiple shadows.

Area Covering Power

Covering power is another vitally important factor in studio set lighting. This term applies to the area of a set which can be lighted to a given intensity with a single lamp, and may be defined in terms of the diameter of the spot over which this intensity can be obtained. The diameter of the spot, of course, is dependent upon the *projection throw* and the *beam spread*.

In this important respect the carbon arc exhibits marked superiority over any other light source, because of the high



M-R TYPE 170 ARC SPOTLAMP

showing 24-inch diameter Fresnel-type lens and series resistance unit. This lamp uses a 16-mm rotating H. I. studio positive carbon and a 1/2-inch studio negative carbon at 140-180 amperes.

lumen content of the light beam it produces.

When the term "boundary light" is used in motion picture photography, it is taken to mean the point where the projected light intensity is 10% of that at the center of the set. However, not infrequently more than 10% of the maximum center intensity may be required in certain cases, thus Table 2 shows covering power values for boundary intensities of 50% of the center set value.

The foregoing definition of covering power is applicable for the figures given in Table 2 for the lamps and film conditions considered previously. It is appar-

ent from Table 2 that the carbon arc lamps at minimum spot can effectively cover set widths ranging from 10 to 40 feet on the basis of a 10% boundary intensity—which coverage is in sharp contrast to that of inkies which are limited to about one-half of this. For a 50% boundary light intensity, the carbon arc at minimum spot coverage is about one-half to two-thirds as much as it is for the 10% level.

Full Flood Position Best

Much greater covering power is obtainable with the carbon arc at full flood than at the minimum spot position, because of the greater lumen output at the flood position. Also, the covering powers of the 50% and the 10% boundary intensities are more nearly identical at full flood, the result of a more uniform distribution of light across the wider beams.

Set areas which can be illuminated to a given intensity will naturally depend upon the square of the corresponding beam diameters shown in Table 2. It is not possible to specify these areas even in a general way, since the angle at which the light beam strikes a given set is dependent upon the particular effect desired.

Figure 2 is a scale diagram of data from Tables 1 and 2 showing the penetrating power, beam diameter and beam spread of the various carbon arc and inkie lights. This graphically portrays the outstanding ability of carbon arc lamps to project over long distances and to cover large set areas.

Shadow Formation, Structure

The formation and structure of shadows formed by a light source, as shown in Fig. 3, is a subject for unending exploration by lighting technicians. That

FIGURE 2. Scale diagram showing projection distance, beam spread and beam diameter for equivalent photographic effect at center of beam.

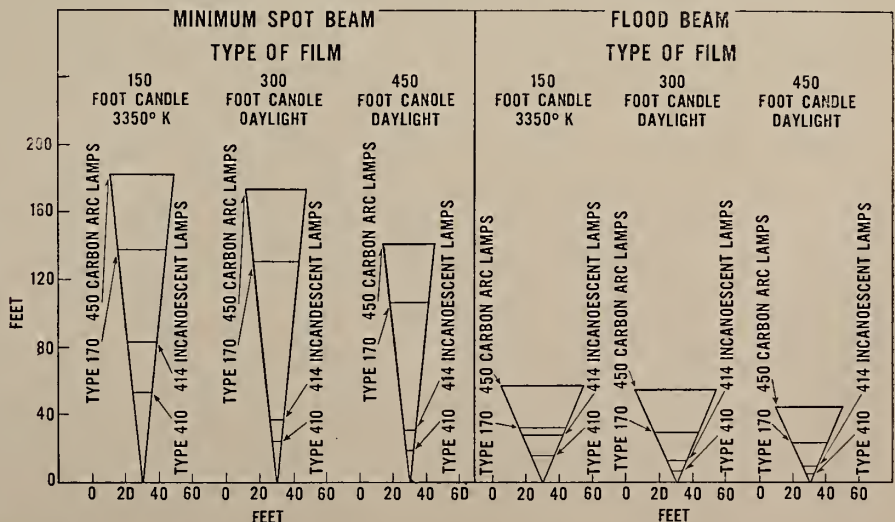

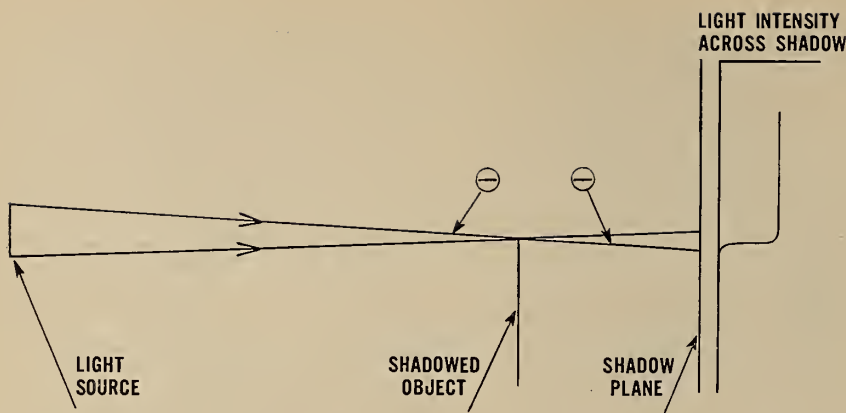

FIGURE 3. Showing how the sharpness of shadows depends on angle subtended by the light source at the shadowed object.

degree of sharpness which is cast by the various lamps is determined by the source size and is measured by the apparent angle subtended by the *effective portion* of the light source at the object producing the shadow.

As is evident from Fig. 3, the area over which the shadow varies from complete darkness to full-light intensity will be smaller and the shadow sharper when the angular extent of the light source (θ) is as small as possible.

Characteristically, only a small portion of the lamp lens surface is effective in illuminating a single area in the beam when the lamp is adjusted for wide beam spreads; but when the lamp is set for narrow beam spreads, a larger portion of the lens surface becomes luminous. It follows, therefore, that when the lamp is adjusted for full flood, the shadows of objects placed at the same distance from the lamps will be sharper than when the lamp is adjusted for minimum spot.

The effective horizontal dimensions of the sources for the extremes of beam spread for each lamp were measured as shown in Table 1. These were determined both visually and by recording the intensity across the shadow of an opaque straight edge. Photometrically, effective source sizes were based upon the width of shadow between the points at which the light intensity was 10 and 90% of the unshadowed intensity.

Source Sizes Factor

The source sizes so determined were found to be smaller than those visually observed (Table 1) and are believed to be a better measure of shadow sharpness. The edges of the luminous spot on the lens surface are not sharply defined, the light tapering downward over a band width which is difficult to define with the eye alone.

Thus, although the entire area of the Fresnel lens appears visually luminous at minimum spot, much of the outer area is of relatively low brightness and is es-

entially ineffective in contributing to shadow formation.

With the 150 foot-candle balanced film, the arc lamps produce up to 50% sharper shadows than the inkies at minimum spot, and as much as three-fold sharper shadows at 45° flood. Because of heavy filtering and close projection distances necessary to get required intensities, both daylight films result in pronounced poorer sharpness of shadows with inkies (larger source sizes).

Table 2, shows that *all* the carbon arc lamps at *all* conditions produce a shadow sharpness essentially equivalent to or sharper than the sun. As previously indicated, much sharper shadows are produced at full flood than at minimum spot. The small source size and the high brightness of the carbon arcs enable them to produce *useful* intensities of radiation with a shadow sharpness surpassing that obtained from the sun and from other studio lighting sources.

Thermopile measurements of the total radiant energy from the carbon arcs show that the unfiltered lamps have a luminous efficiency of approximately 75 to 100 lumens per watt in the beam. Similar measurements using a gelatin filter combination with one MT-1 and two Y-1 filters resulted in approximately 50% loss in visual candlepower, but correspondingly reduced the total radiant energy, so that there was only a 10 to 20% loss in luminous efficiency. This filter combination is the one presently used with carbon arcs and 3350° K. film.

Inkie tungsten lamps used for studio lighting are reported to have a luminous efficiency of 35-40 lumens per watt. With or without the gelatin filter combination on the arcs, the luminous efficiency of carbon arc lamps is thus at least twice that with tungsten, to give half the heat for the same light intensity. This explains the much greater coolness conventionally associated with carbon arc light, and indicates that this advantage is maintained with the gelatin filter combinations and the new color films.

It is interesting to note that the carbon arc lamp approaches the sun in luminous efficiency as well as in color quality, the solar efficiency being approximately 100 lumens per watt.

Summarization

The small source size, high brightness and high unit power of the carbon arcs make possible their outstanding superiority in penetrating power, covering power and shadow sharpness, compared to other available light sources. The daylight quality of the light is responsible for the coolness of the radiation and permits ready interchangeability with daylight in color photography.



Compliments of the Season

LOS ANGELES LOCAL NO. 150

I. A. T. S. E.



Bright in the corner

● The finger of light that suddenly shows the phantom figure in brief, bright prominence is a tribute to imagination—to the inspired use of techniques, equipment, and materials—often a result of close collaboration between industry technicians.

To help, the Eastman Kodak Company provides a highly specialized staff of motion picture engineers and technicians to advise in selecting film, help solve processing problems, make sure prints and theater equipment are right for efficient projection.

In order to maintain this service, the Eastman Kodak Company operates branches at strategic centers . . . invites inquiry from all members of the industry. Address
Motion Picture Film Department,
Eastman Kodak Company,
Rochester 4, N. Y.;

East Coast Division,
342 Madison Avenue,
New York 17, N. Y.;

Midwest Division,
137 North Wabash Avenue,
Chicago 2, Illinois;

West Coast Division,
6706 Santa Monica Blvd.,
Hollywood 38, California.

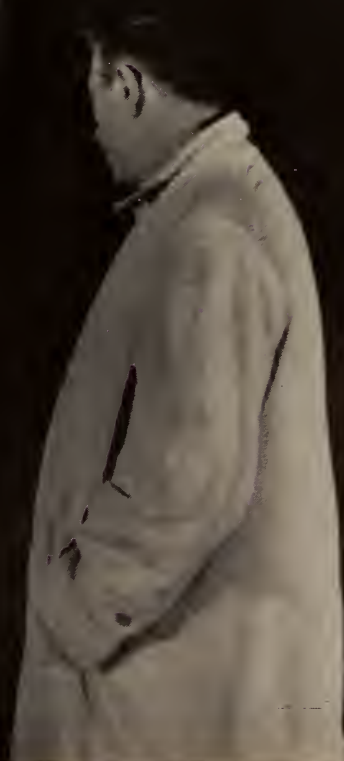

Dedicated to...

THE ALL-COLOR SCREEN

TECHNICOLOR

IS THE TRADE MARK OF

TECHNICOLOR MOTION PICTURE CORPORATION

HERBERT T. KALMUS, PRESIDENT AND GENERAL MANAGER

The Allied Arts and Sciences

A vast field of artistic and scientific endeavor is directly contributory to the motion picture process and, therefore, to the practice of projection. The true craftsman should have a well-rounded understanding of these contributory factors, particularly in view of the imminent widespread utilization of television and, possibly, stereoscopic pictures and stereophonic sound. This department will provide basic information on the aforementioned arts and sciences, a wide variety of topics being a primary aim.

IV. Photographic Optics (Conclusion)

Bausch & Lomb Optical Company, Rochester, New York

IN THE discussion of the pinhole camera we were apprised of the disc which takes the place of our ideal image point, and further we found that we cannot perceive a disc of about $3/1000$ th inch as a disc, but we see it as a point. It was said there that this disc image permitted pictorial photography, in that it is responsible for depth of field.

To see this, consider the path of rays near the focal point. It is evident that a certain displacement is possible in the focal plane without exceeding the disc size. Throughout this range the subject remains substantially in focus, and, conversely, objects on either side of the subject focused upon are in apparent focus. This depth in the object space is called *depth of field*, contrasting with the depth of focus in the image space.

(These two terms are often confused. Strictly, the distance between the farthest and nearest *object* planes in acceptable focus on the film is defined as depth of field. The separation between their points of focus near negative or image is the depth of focus. Fig. 27).

The Hyperfocal Distance

If our lens is focused on infinity, obviously there will be a finite distance represented in focus on the screen. This distance bears the name of the *hyperfocal distance*, and is of great importance in depth of field computations.

The hyperfocal distance has a very interesting property: if a lens is focused on the hyperfocal distance, then everything from half that distance to infinity will be in focus. The depth of field is at that point the maximum attainable. The lenses in fixed focus cameras are set for the hyperfocal distance, for then the maximum usefulness will be attained. Many movie camera lenses are also set for hyperfocal distance.

A few of the depth-of-field relations are easily seen from a serious study of the diagrams. Thus: the smaller the stop, the greater the depth with a given lens; the far depth is greater than the

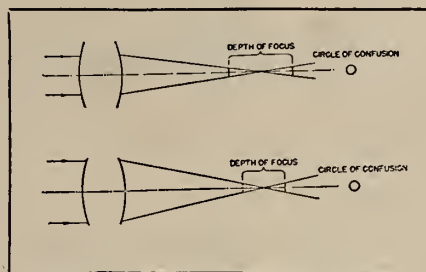

FIG. 27. Depth of field and aperture.

near depth; the depth decreases with decreasing object distance, so that focusing is more critical at short distances; with

a given object distance, the depth is greater with a shorter focal length—for this reason miniature cameras show advantages in depth of field over their bigger brothers.

Supplementary Optics

The use of supplementary lenses permits the attainment of effects impossible with the camera lens provided by the manufacturer. A battery of simple lenses, judiciously used, is equivalent to a collection of objectives. However, there are certain precautions to observe in order to derive the utmost in satisfaction from these lenses.

Either positive or negative lenses can be used as supplementaries, if the camera has considerable bellows extension. If, on the other hand, the lenses are to be used with single-extension bellows cameras or with fixed focus cameras, only the positive lens type will be suitable.

Perhaps the most generally useful supplementary lens is a simple positive lens, for it can serve both as a wide angle lens or as a portrait or tabletop attachment. These lenses come in various powers, 3 diopters being about the maximum useful. (One diopter of lens power is possessed by a lens of 1 meter—39.37 inches—focal length; in general the power in diopters of a lens is found by dividing



Season's Greetings

NATIONAL CARBON COMPANY

A Division of Union Carbide and Carbon Corporation

NEW YORK



its focal length in meters into 1. For example, a 2-meter lens has a power of one half diopter, a 500 millimeter lens a power of two diopters.)

Use of Two Positive Lenses

When a positive lens is used with another positive lens, the power of the combination is equal closely to the sum of the individual powers. Thus our positive supplementary lens increases the power of the camera lens; or, expressed differently, we have converted our camera lens into a shorter focal length lens. With a fixed focus objective on our camera, this means the possibility of making pictures of near objects, their distance determined by the focal length of the combination and the focal length of the original lens.

If we have a camera with bellows, we have another possibility—the use of our supplementary as a wide-angle lens. We have noted that the angle of view embraced in a negative is determined by the focal length of the objective with respect to the film size. Since our positive supplementary shortens the focal length of our camera lens, it becomes then a wide-angle lens, and can be used as such.

A negative supplementary can be used only with a camera having a bellows extension greater than normal, for it will effectively increase the focal length of the lens, serving as a substitute for a telephoto lens.

In the use of these lenses, it is necessary to correct for the effect of the lens on the stop markings. Since the effective relative aperture is given by the ratio of the lens-to-film distance to the lens open-

Season's Greetings
to those craftsmen whose preference for
fine equipment has contributed so much
to the progress of the industry.

Neumade
TRADE MARK

330 West 42 Street New York 18, N. Y.

Holiday Greetings From

CAMERAMEN'S LOCAL NO. 659
I. A. T. S. E.

HOLLYWOOD **CALIFORNIA**

ing, when that distance is altered the stop value is accordingly changed, so that the exposure will no longer be given directly by the diaphragm markings.

Heavy Aberrations Result

These effects, of course, are the more pronounced the stronger the supplementary, as are the defects of these lenses. Indeed, the heavy aberrations introduced by these lenses limit the useful powers to comparatively modest limits.

Our camera objectives are carefully designed so that they deliver the best sort of image most economically, and are corrected to work alone, and theoretically at one range of object distances, usually including infinity. Now, if we were to place in front of our lens another, we would inevitably upset these corrections.

Not too much relief is possible in the design of the supplementaries, since they must be reasonably priced. For this reason a delicate balance is achieved between the corrections best for a wide variety of camera objectives, and the cost of perfection. These lenses must be used with caution, and at a small aperture to minimize the effects of the aberrations causing unsharpness. Of course, no relief is possible in this way for the aberrations independent of aperture: astigmatism, distortion, and chromatic aberrations.

Filter and Diffusion Discs

There are two more types of supplementary attachments we might briefly mention—filters and diffusion discs. The color characteristics of the common filters have been discussed previously herein, and complete data is available elsewhere, so beyond mention of the fact that the filters of glass or cemented gelatin can introduce aberrations, if the filter is of poor quality, we shall go no further.

Diffusion discs accomplish what the older photographers did with the soft focus lenses—the introduction of extraneous light into the image, softening detail. This is accomplished in the diffusion discs by means of lines and/or cir-

Cordial Season's Greetings

FROM

**GENERAL
PRECISION
LABORATORY**

INCORPORATED

PLEASANTVILLE, NEW YORK

Makers of
**VIDEOFILM and SIMPLEX
THEATRE TELEVISION SYSTEMS**

GIVE YOUR SHOW MORE SPARKLE

with these Modern, Economical Spotlights for Every Need



Favored throughout the world by those who know spotlights best because they give so much more light and are so much easier to operate.

The
STRONG TROUPER HIGH INTENSITY ARC SPOTLIGHT

For large theatres, arenas, ice shows and auditoriums.

Projects a sharp, snow-white spot without the use of heavy rotating equipment. Quiet . . . flickerless . . . portable. Draws only 10 amperes from one 110 volt A. C. convenience outlet. Adjustable, self-regulating transformer in base. Silvered glass reflector. Two-element variable focal length lens system. Automatic arc control. A trim of carbons burns one hour and 20 minutes at 21 volts and 45 amperes. Easily disassembled for shipping.

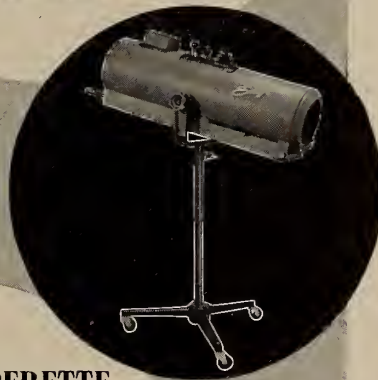

The
STRONG TROUPERETTE INCANDESCENT SPOTLIGHT

For small theatres, hotels, night clubs, schools and colleges.

Projects 6½ times brighter head spots. Sharp edge from head spot to flood. As contrasted to conventional incandescent spotlights, with which the spot size is varied solely by iris, to result in substantial light loss, the Trouperette utilizes all the light through most of the spot sizes. Variable focal length objective lens system. Horizontal masking control. Color boomerang. 5¼" gloss reflector, Fresnel lens. Plugs into 110-volt convenience outlet.

SEE ANY OF THE FOLLOWING DEALERS
 OR USE COUPON FOR OBTAINING
 LITERATURE

- ALBANY, N. Y.—Nat'l Theatre Supply Co.; Albany Theatre Supply.
- ATLANTA—Nat'l Theatre Supply Co.
- ATLANTIC CITY—Boardwalk Film Enterprises.
- AUBURN, N. Y.—Auburn Theatre Equipment.
- BALTIMORE—J. F. Dusman Co.; Nat'l Theatre Supply Co.
- BIRMINGHAM, ALA.—The Queen Feature Service, Inc.
- BOSTON—J. Cifre, Inc.; Nat'l Theatre Supply Co.
- BUFFALO—Dion Products; Nat'l Theatre Supply Co.
- CHARLOTTE—Nat'l Theatre Supply Co.; Standard Theatre Supply Co.
- CHICAGO—Abbott Theatre Equip. Co.; Droll Theatre Supply Co.; Gardner Jansen, Inc.; Grand Stage Lighting Co.; Hollywood Stage Lighting Co.; Midwest Stage Lighting Co.; Nat'l Theatre Supply Co.
- CINCINNATI—Nat'l Theatre Supply Co.
- CLEVELAND—Nat'l Theatre Supply Co.
- DALLAS—Hardin Theatre Supply Co.; Modern Theatre Equip. Co.; Nat'l Theatre Supply Co.
- DAYTON, OHIO—Sheldon Theatre Supply
- DENVER—Nat'l Theatre Supply Co.; Graham Bros.
- DES MOINES—Nat'l Theatre Supply Co.
- DETROIT—Nat'l Theatre Supply Co.
- FORTY FORT, PA.—V. M. Tate Theatre Supplies.
- GREENSBORO, N. C.—Standard Theatre Supply Co.
- HOUSTON—Southwestern Theatre Equip. Co.
- INDIANAPOLIS—Nat'l Theatre Supply Co.
- KANSAS CITY, MO.—Shreve Theatre Supply; Nat'l Theatre Supply Co.
- LOS ANGELES—J. M. Boyd; C. J. Holzmuller; Nat'l Theatre Supply Co.; Pembrex Theatre Supply Corp.
- LOUISVILLE—Falls City Theatre Supply Co.
- MEMPHIS—Nat'l Theatre Supply Co.
- MILWAUKEE—Nat'l Theatre Supply Co.; R. Smith Co.
- MINNEAPOLIS—Minneapolis Theatre Supply; Nat'l Theatre Supply Co.
- NEW HAVEN—Nat'l Theatre Supply Co.
- NEW ORLEANS—Nat'l Theatre Supply Co.
- NEW YORK CITY—Nat'l Theatre Supply Co.
- NORFOLK—Nat'l Theatre Supply Co.
- OKLAHOMA CITY—Nat'l Theatre Supply Co.; Oklahoma Theatre Supply Co.; The Century Theatre Supply Co.
- PHILADELPHIA—Blumberg Bros.; Nat'l Theatre Supply Co.
- PITTSBURGH—Atlas Theatre Supply; Nat'l Theatre Supply Co.
- SALT LAKE CITY—Inter-Mountain Theatre Supply Co.
- SAN FRANCISCO—C. J. Holzmuller; Nat'l Theatre Supply Co.; W. G. Preddey Theatre Supplies.
- SEATTLE—B. F. Shearer Co.; Nat'l Theatre Supply Co.
- SIOUX FALLS—American Theatre Supply Co.
- ST. LOUIS—City Electric Co.; Nat'l Theatre Supply Co.
- TOLEDO—Theatre Equip. Co.
- WESTERLY, R. I.—G. H. Payne Motion Picture Service.
- CANADA—Dominion Sound Equipment, Ltd., Montreal, Quebec; General Theatre Supply Co., Toronto, Ontario; General Theatre Supply Co., St. John, N. B.; General Theatre Supply Co., Vancouver, B. C.; General Theatre Supply Co., Montreal, Quebec; General Theatre Supply Co., Winnipeg, Man.; Sharp's Theatre Supplies, Ltd., Calgary, Alta; Perkins Electric Co., Ltd., Montreal, Quebec; Perkins Electric Co., Ltd., Toronto, Ontario.

THE STRONG ELECTRIC CORPORATION
*"The World's Largest Manufacturer of
 Projection Arc Lamps"*

14 CITY PARK AVENUE TOLEDO 2, OHIO

Please send free literature on the Strong Trouper Arc
 Spotlight; Strong Trouperette Incandescent Spotlight.

NAME.....
 COMPANY.....
 STREET.....
 CITY & STATE.....



Season's Greetings

To Our Projectionist Friends Everywhere

from

NATIONAL THEATRE SUPPLY

and

INTERNATIONAL PROJECTOR CORPORATION



cles in intaglio or relief ground and/or polished into the surface of a glass disc. These ridges or valleys act as sections of lenses, and scatter the light which would normally reach the image, spreading it over the whole of the image plane. Naturally, the exposure must be increased when one of these attachments is used.

The Enlarger

The enlarger is one of the most important and interesting pieces of photographic equipment. Essentially it is a camera with an illuminated negative. The most interesting aspect of the enlarger is its illumination, which may be of two fundamental types, *diffuse* or *condenser*. These two types differ basically in their action.

Diffuse illumination, achieved by inserting a ground or opal glass between the negative and the illuminating lamp, of necessity provides the softest illumination of the negative, and thus, directly, the least harshness upon projection.

To see this, consider a typical negative with a wide range of tones. The opal glass diffuses the light thoroughly, that is, the emergent light is scattered in all possible directions. But the lens can pick up only that light which is directed toward it. Each element of the negative will be sending light to fill the aperture of the lens, and the shadows cast on the lens by the dark negative areas will be receiving light from the adjacent lighter areas.

Expressed in different words, in diffuse illumination the negative shadow areas are weakened, meaning that the contrast is lowered. This then necessitates either using a contrastier grade of paper, or making more contrasty negatives.

Condenser Illumination Action

The situation is quite otherwise with condenser illumination, for there, under the best operating conditions, the dense areas are not diluted by scattered light and the full contrast of the negative is effective. However, the conditions to be observed in condenser illumination appear to be unfamiliar.

It would be taken as a *cliche* if we

Season's Greetings

To the thousands of craftsmen who have proven the superior quality of

LORRAINE CARBONS

ED LACHMAN, President

CARBONS, INC.

Season's Greetings

LOCAL NO. 293, I. A. T. S. E.
NEW ORLEANS, LA.

A. S. JOHNSTONE
President

A. T. WEISS
Secretary

were to be reminded that a lens is most efficient in yielding bright images when it was filled with light, yet that is the condition too often forgotten in enlarging or projection. To achieve that state, it is necessary only to image the light source at the diaphragm of the enlarging lens, and to use condensers whose effective F-number is equal to that of the lens. If the condenser F-number is less than that of the enlarging lens, the latter has been optically stopped to the condenser number.

When the enlarging lens has been filled with light at its full opening, it will remain so at other stops. But maintaining this condition of imaging the light source in the diaphragm plane necessitates focusing the light source for each change of magnification, since then the condenser lens distance changes. This, together with the accuracy necessary in alignment of condenser systems, has resulted in their being less popular than the diffu-

sion systems, in spite of the tremendous advantages enjoyed by condensers in illumination. It is easy to see that the illumination in a diffuse enlarger is very much less.

Enlarging Lenses

A word about enlarging lenses. It was not specifically pointed out in the discussion of the lens aberrations that the aberrations can be corrected for but one object position; (for many practical purposes however, they depart little from this ideal correction for relatively large changes of object positions). This unfortunate fact hampers the designer in his work, for he then must make a lens for one specific job, and when radically different conditions are imposed, he must design another lens.

Enlarger lenses have been so corrected that they will work best at short conjugates, and will give inferior images in general for an infinite object. Camera lenses, on the other hand, have been designed to give their best images of an infinite to distant (down to perhaps 10 times focal length) object, and cannot be expected to do a top-notch job in an enlarger.

The common impression that for best results *enlarge* with the taking lens is mistaken. Of course, if the photography is first rate, and if the lens is stopped down, a camera lens may give satisfactory enlargement, but then better quality would certainly have been achieved with a lens specifically designed for the enlarging job.

[THE END]

Greetings and Best Wishes

PROJECTIONISTS LOCAL NO. 407

I. A. T. S. E. & M. P. M. O.

SAN ANTONIO

TEXAS

The GPL 'Simplex'

Direct-Projection Theatre Tv System

By FRANK N. GILLETTE

General Precision Laboratory, Pleasantville, N. Y.

The data given in this article are based on a series of oral-demonstration presentations given by GPL engineers in various sections of the United States, and notably on that presented before 400 projectionists at the November meeting of the 25-30 Club of Greater New York.

SIMPLICITY in installation, convenience in maintenance, and reliability in operation were the goals in the development of the Simplex direct-projection Tv system (Model PB-600) manufactured by General Precision Laboratory. Included is every facility required for operation from every standard source of Tv signal and for presenting on the theatre screen a full-size Tv picture of the highest quality.

Three units comprise the equipment; an optical barrel, a control panel, and a high-voltage supply; their installation location is shown in Fig. 1.

Equipment's Three Units

The high-voltage supply can be installed in any convenient location. It has no controls, meters, or switches mounted on it and should require no attention for months at a time.

The control panel contains all operating and the great majority of alignment and service controls. This unit would normally be installed in the projection room, many alternative locations are possible.

The optical barrel installation, however, is governed by the fact that the projection optics have a fixed focal length and an extremely wide aperture, the location for the barrel is restricted to rather narrow limits by the size and location of the projection screen. The screen should be selected for the best reflection incident light into the audience area. Beaded screens are acceptable only in narrow theatres; in wider theatres they give poor performance because of the large reflection angles.

15 x 20-Foot Screen Image

The optical system provides a picture 15 feet high and 20 feet wide at a throw distance of 62 feet. The system

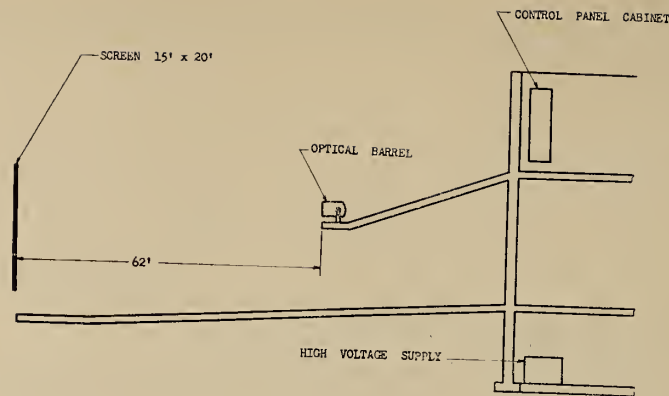

FIGURE 1
Showing the usual locations of the GPL theater Tv units. Modification of these locations is not only possible but sometimes necessitated by structural requirements.

does permit some variation of picture size and throw, but there are also some unyielding restrictions on such variation. Specific attention is directed to the nature and source of these limitations.

Figure 2 shows the optical elements. The picture is formed on the face of the cathode ray tube at "T". Light from the tube face is collected by the mirror at "M" and directed toward the projection screen at "S". The corrector plate is inserted at "P" so as to correct for aberrations, principally spherical aberration, of the mirror.

The design of the entire optical system is fundamentally controlled by the cathode ray tube, in this case a type 7NP4. For good focus over the entire picture area it is necessary that the curve of the mirror be essentially concentric with the curve of the tube face. It is further necessary that the tube face be located approximately at the focal point of the mirror.

Since the focal length of a spherical mirror is equal to one half its radius of curvature, the foregoing conditions result in a mirror having a radius of curvature twice that of the cathode ray tube and a system having a focal length equal to the radius of curvature of the tube face.

10% Permissible Image Change

With the focal length fixed in this way, there is a single value of magni-

fication for any chosen throw distance. Thus picture size at a fixed throw distance can be changed only by changing the size of the picture on the cathode ray tube. If the size be increased too much, the corners will be clipped by the edge of the tube. If the size be decreased appreciably, resolution will suffer. In practice, the dimensions of the picture can be varied some 10% either way from the nominal size.

The magnification is, of course, a linear function of the throw distance; but throw distance is not readily controlled, being strongly influenced by theatre design, and can be manipulated only by reconstruction of a more or less extensive nature. If the preferred installation location provides a throw that is too short, use of a smaller screen is possible and provides the attendant advantage of increased screen brightness. If the preferred location gives a throw

FIG. 2. Optical elements.

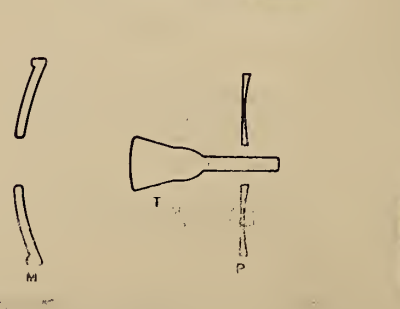

that is too long, the only answer is theatre modification. Increasing the screen size won't do, because the brightness soon becomes unacceptably low.

Theatre people are familiar with these relationships, but unfortunately they are also accustomed to purchasing projection lenses in many different focal lengths so as to satisfy almost any requirement. Naturally, they expect similar flexibility in theatre Tv equipment.

Factors Controlling Flexibility

The cost of designing and stocking expensive optical systems of different focal lengths is one obvious reason for not offering such flexibility. Other and more forceful reasons are indicated in Fig. 3.

Here the central figure shows the components of our present optical system. The upper diagram shows a system of shorter focal length, and the lower a system of longer focal length. As drawn, the three systems have equal geometrical apertures and so will provide approximately the same screen brightness.

It will be noted that the diameters of the optical elements of the system of longer focal length are considerably larger than the elements of the Simplex system. Not only are such elements much more expensive than those used in the present system, they are also larger than can be manufactured in quantity by existing equipment.

The system of shorter focal length involves smaller components which could indeed be manufactured at reasonable cost. However, the angular width of the picture becomes significantly greater. As

NOTE 1. That is, this would have been true had Fig. 3 been drawn correctly. The three tube diameters should be equal rather than proportional to focal length as shown in Fig. 3.

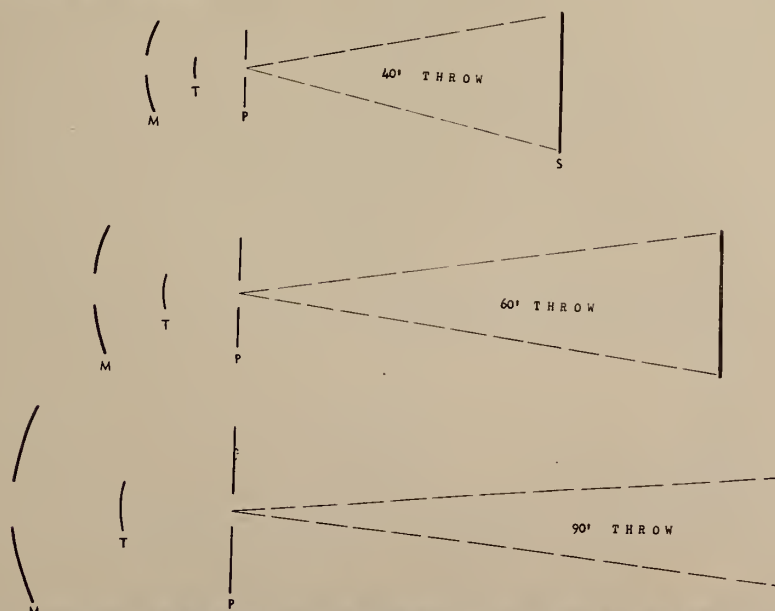

FIG. 3. Showing the effect upon the image through the use of lenses of various focal lengths.

this angular width becomes larger, the optical design problem becomes tremendously more complex. Adequate correction of optical aberrations in the corners of the picture becomes virtually impossible.

Variation of Schmidt System

Although an optical system of this type is generally called a Schmidt system, it differs tremendously from the system originally developed by Schmidt for use as an astronomical telescope. Fundamentally a Schmidt system consists of a spherical mirror, a diaphragm located at the center of curvature of the mirror, and a corrector plate also located at the center of curvature. The diaphragm serves to eliminate third-order aberrations, and the corrector plate provides compensation for spherical aberration.

The optical quality of this system can indeed be very good, provided the design is restricted to an angular field of something like 1 degree and an aperture less than F:3. For the Simplex system we require an angular field of 23 degrees and a geometrical aperture of F:7. Clearly, these requirements are well beyond the limitations of the basic Schmidt design.

The classical Schmidt formulae have been applied to the present conditions with a reasonable degree of success. However, much better results have been obtained by approaching the design problem from a somewhat different point of view. Mr. Louis Raitiere of our staff developed a design approach which results in a system that differs slightly but very significantly from the Schmidt system. The performance thus obtained has been gratifying. We observe a limit-

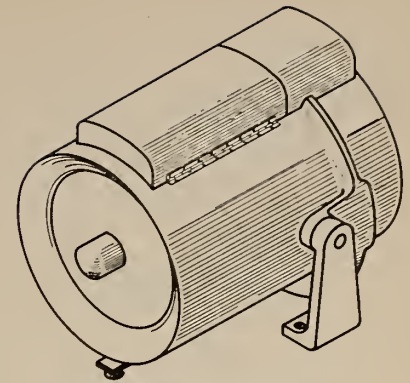

FIG. 4. Projector optical barrel.

ing resolution in the extreme corner of the field of 2000 Tv lines per picture height. This figure, of course, applies to the optical system alone and not to the overall system.

Completely Enclosed Optical Barrel

The detail contrast ratio that is obtainable in any system which works with a cathode ray tube as the basic picture source is never as much as one would desire. The contrast ratio is still further degraded by the presence of any dirt on the optical elements of the system.

To reduce the rate at which dirt collects on the optical elements, and consequently to minimize the necessity for frequent cleaning, the optical barrel shown in Fig. 4 is completely enclosed and there is no circulation of outside air through the system. The cooling air which must be directed against the face of the cathode ray tube to avoid damage to the tube is recirculated through the barrel and serves only to conduct heat from the cathode ray tube to the outer walls of the barrel. The outside of the barrel provides such a large radiating surface that the resulting temperature rise is insignificant.

The use of a closed system also permits quite simple solutions to any problems arising from excessive humidity. We have thus far had no difficulty with arc-over within the barrel; but should such difficulty develop, we anticipate no trouble in controlling the humidity within the unit.

The barrel is supported mechanically at three points. The two pivot points are located at approximately the center of gravity and carry the bulk of the weight of the unit. The third support point is at the bottom of the front of the barrel. Its function is to tilt the barrel and to hold the line of sight once it is established. The maximum tilt that is permissible from optical considerations is approximately 7 degrees. If it is possible to tilt the screen, a greater tilt of the barrel can be accommodated by the mechanical adjustment provided.

The barrel opens at the top for clean-

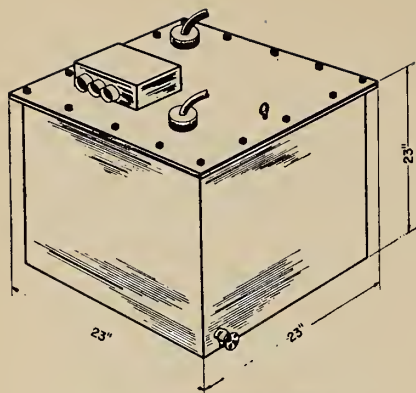

FIG. 5. High-voltage supply.

ing and service. The video amplifier and the alignment controls are located here, which makes readjustment or tube replacement very simple. Of course, there are no more tubes in the barrel than is absolutely necessary. Only the final video amplifier is located here.

Cathode Ray Tube

The cathode ray tube is mounted in the deflection yoke which is in turn held by a support arm that hangs from the top of the barrel. The support arm fastens to a mounting plate from which it can easily be removed and to which it returns without disturbance of previously made alignment adjustments.

All alignment adjustments required by tolerances of the cathode ray tube itself are made on the support arm assembly. Thus any projectionist can equip himself with a spare tube support arm in which he can mount and align a spare cathode ray tube to have it in instant readiness for replacement. To facilitate this operation, all electrical connections to the cathode ray tube and the deflection yoke are carried up the tube support arm to connectors that can be quickly disconnected in time of need. Thus a show need not be lost for more than three minutes by failure of the cathode ray tube.

The 80 Kv power supply is shown in Fig. 5. This unit provides the anode voltage for the cathode ray tube and also the focus voltage.

Power Supply Circuit

The circuit is a 60 voltage doubler using two type VR3B rectifiers. The output voltage is regulated against variation in both line voltage and load current by an electronic regulator, which controls a saturable reactor in series with the primary of the high-voltage transformer. The regulation characteristic is essentially flat from zero current to 2.5 milliamperes. Beyond 2.5 milliamperes the voltage drops rapidly with increasing current in the manner required for protection of equipment

against permanent damage in case of momentary failure.

The focus voltage is bled down from the 80 Kv level to take advantage of the stability of that level and to provide a focus voltage that will remain proportional to the anode voltage should any variation in that level occur. Remote control of the focus voltage is provided by a high-voltage triode used as a shunt across the low end of the focus bleeder.

Control Panel Cabinet

The unit is oil-filled for maximum reliability. It also contains a number of electrostatic shields and protective spark gaps on the low-voltage wiring to insure that any breakdown which might occur inside the unit will have no harmful effect on external circuits.

The projection room equipment consists of the Control Panel Cabinet (Fig. 6). It is a double-relay rack, each rack being of the standard width to accommodate 10-inch panels.

The rack itself possesses a number of special features that deserve mention. The component chassis are strictly conventional, each one consisting of a horizontal chassis with a vertical front panel of standard 19-inch width. However, the method of mounting is such as to provide much greater serviceability than is usually found in equipment constructed in this fashion. Each individual chassis is held in place with two quarter-turn locks. When these are released, the chassis may be drawn forward on rollers until it is fully clear of the rack. This provides quick access to all of the

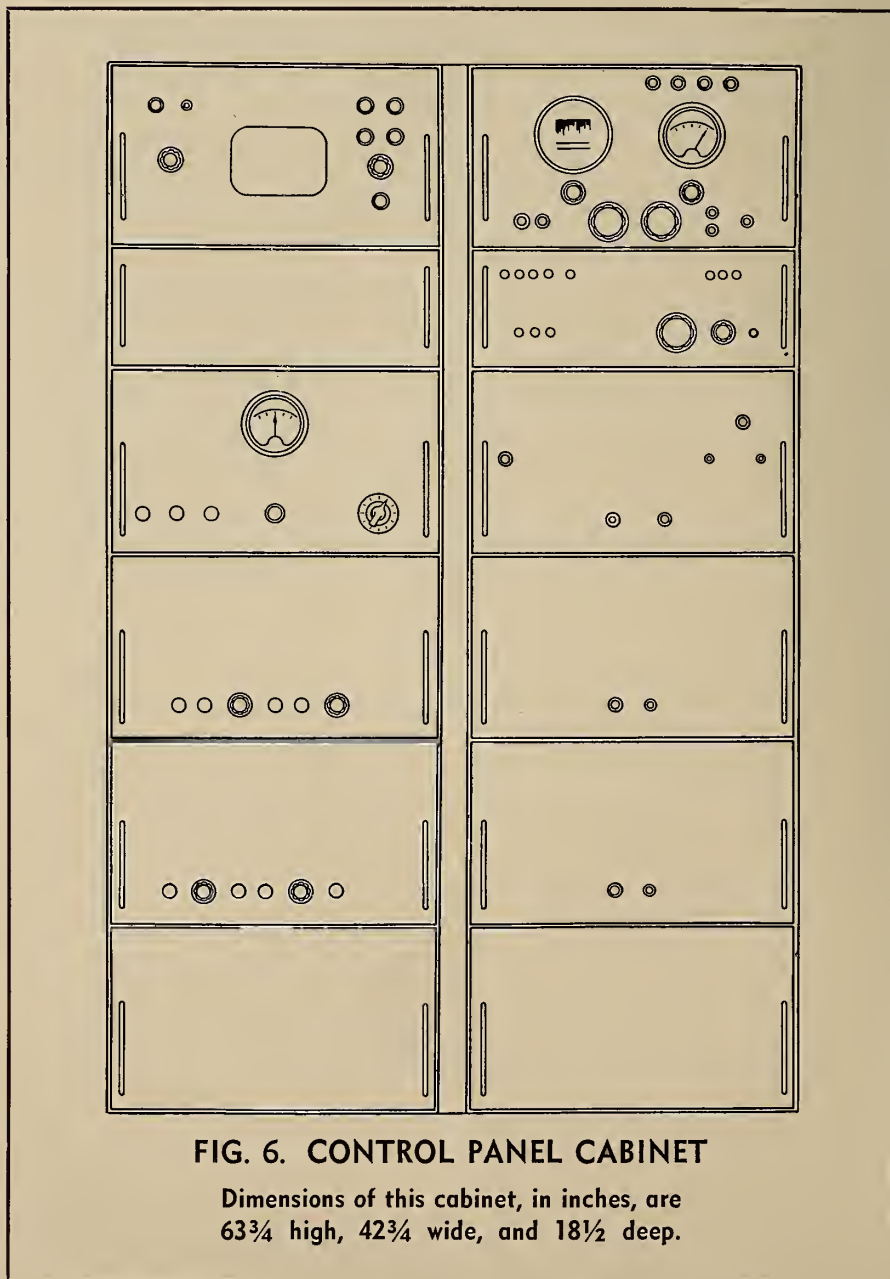

FIG. 6. CONTROL PANEL CABINET

Dimensions of this cabinet, in inches, are 63 $\frac{3}{4}$ high, 42 $\frac{3}{4}$ wide, and 18 $\frac{1}{2}$ deep.

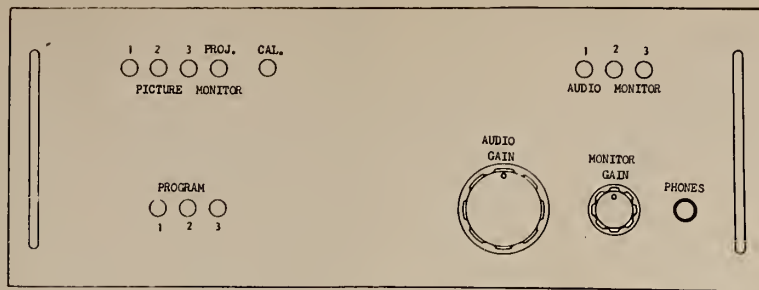

FIG. 7. Program selector panel.

tubes in the rack without the removal of cover plates or other ornamentation.

Should the wiring side of the chassis require attention, it is only necessary to lift the front of the chassis and swing it upward through 90° where it will rest in a stable position with the wiring facing outward. In either of these positions the chassis are still connected and still operating.

These provisions make it possible to perform all service functions without access to the rear of the rack. This same thought has been carried further. When all the chassis are removed from the rack, there remains but an empty shell. As a first step in installation, this shell can be bolted down, once and for all, in its final position, even though this places the back of the cabinet solidly against a wall. The conduits and cables can then be affixed and the chassis installed without further movement of the cabinet.

Control Unit Placement

The equipment in the racks is so distributed as to place the monitors and meters at eye level, and the operational controls at convenient finger tip level.

The unit in the upper left corner is the Picture Monitor containing its own power supply. The controls on this unit serve only to adjust the picture on the 8½-inch monitor tube.

Below the monitor is a receiver of rather superior characteristics provided for off-the-air reception during periods of test and alignment. (In Fig. 6 a blank panel is shown between monitor and receiver. In the production equipment this blank panel has been moved down to the bottom position to place the receiver at a better level for observation of the tuning meter).

The two units below the receiver are the vertical and horizontal deflection chassis. These units contain all of the deflection controls, circuits, and components except the deflection yoke, which is necessarily located with the projection tube in the optical barrel. The deflection circuits and components are especially designed to permit a long cable to the deflection yoke. With the cable usually provided, this run can be 150 feet. With special low-capacity cable

even longer runs are possible. This point is mentioned particularly because this cable run is the only one in the system that bars any restriction as to length.

Below the deflection chassis are two blank panels (although Fig. 6 shows but one) behind which is located a line-voltage regulator that stabilizes the input voltage to various circuits that are not sufficiently critical to demand electronic regulation and to the filament transformers of more critical circuits.

In the right-hand rack the bottom panel is also blank. In this space is mounted the saturable reactor which regulates the 80 Kv supply.

The two chassis next above contain power supplies which provide the various plate and bias voltages required by all of the circuits except the monitors.

Above the power supplies is located the Hi-Voltage Control Unit, which contains all of the low-voltage elements associated with supply except the saturable reactor mentioned previously. The panel controls consist of push-buttons for controlling power to the supply and a knob for setting focus voltage level.

The remaining two panels in this rack are shown in more detail in the following illustrations. Fig. 7 shows the program selector panel located immediately above the high-voltage control unit. All signal switching and audio control functions of the equipment are performed on this panel.

Three Incoming Channels

The system provides for three incoming program channels, each consisting

of an audio and a video line. Normally one of these channels will be connected to the receiver included in the equipment. The second will take the incoming program line. The third might be used for a parallel safety channel for the main program line, for an auxiliary microwave receiver, or possibly for a local signal generated by pick-up equipment within the theatre.

The switching facilities permit independent monitoring of any incoming audio or video line. The three push-buttons at the upper right connect any of the three audio lines to the monitor headphone jack in the lower right corner of the panel. The gain control for the monitor channel is adjacent to the phone jack. The larger knob sets the gain in the program line to the theatre. This control is used only to set the audio level from the television equipment to the level required by the input of the theatre sound system. It is not considered an operational control.

The push-buttons at the upper left switch the input signal to the Picture Monitor and also to the Waveform Monitor yet to be described. The first three buttons select any of the three incoming video lines. The fourth button, labeled "Projector," will be described in connection with Fig. 8. The fifth button is non-locking and serves to connect a calibrating signal to the Waveform Monitor for use in setting signal levels.

Program switching is done by the push-buttons at the lower left of the panel. They feed any of the three input channels to the theatre system, controlling both picture and sound. Interlocked switching has been used here as another means of eliminating operating error.

Figure 8 shows the Projector Control Panel which is located at the top of the right-hand rack. On this panel are concentrated all but one of the operational switches and controls normally used in turning on and adjusting the picture on the theatre screen. This panel also contains the waveform monitor and a multi-purpose meter, both very useful as moni-

★ ★

Fraternal Greetings

TREASURERS AND TICKET SELLERS

LOCAL UNION NO. 751

I. A. T. S. E.

NEW YORK, N. Y.

★ ★

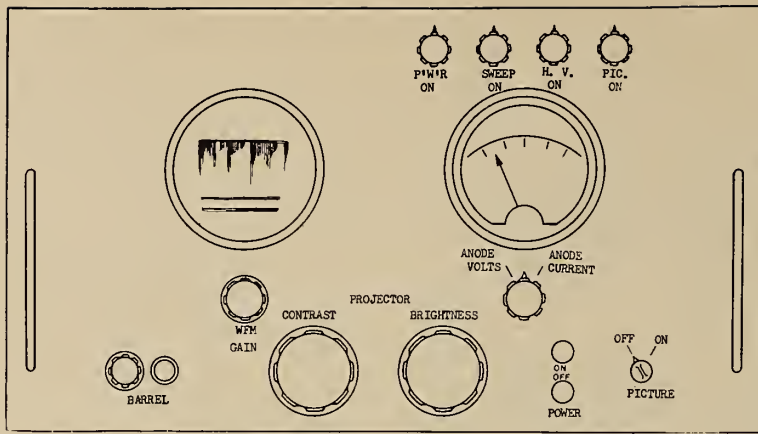

FIG. 8. Projector control panel.

tors during projection and as test instruments during preliminary set-up.

Four-Step Turn-On Procedure

The equipment will normally be turned on by the four-step procedure now to be outlined. Enough interlocks and protective circuits insure that no damage will result in the event of possible occasional operating lapses in turn-on procedure.

The progress of the operation is indicated by the set of four amber lights at the upper right of the Control Panel. Not until all four are illuminated will a picture appear on the projection screen.

As the first step, the main power relay is closed by means of the motor-starting type push-button located below the meter. This lights the first of the amber lights at once.

As the circuits warm up and reach normal operating conditions, the second amber light glows to indicate the presence of deflection fields at the cathode ray tube.

In the second step, power is applied to the Hi-Voltage Supply by means of the push-buttons located on its control panel. In a short time the anode potential rises to its proper level, causing the third amber light to glow.

At this point the entire system is turned on and the three lights inform the projectionist that all interlocks are closed, all supply voltages are present, and most of the circuits are functioning in essentially normal fashion. However, there is still no picture on the projection screen because the projection tube is biased well beyond cut-off.

Meter, Monitor Checking

The third step might be considered optional but is actually essential to good showmanship. It consists of using meter and monitors to preset various controls to insure that the picture first seen by the audience is a good image.

The test meter is used first to check the levels of the various supply voltages, including the 80 Kv anode supply. It is then used to set the operating bias of the projection tube at the proper level by means of the "Brightness" Control. Finally it is turned to the "Anode Current" position to serve as a monitor during the projection period.

The monitors, both picture and sound, are used first to check on the quality and the levels of the incoming signals. Then the picture and waveform monitors are switched to their "Projector" position. In this condition both receive a video signal brought back from the final video stage in the optical barrel, which permits preliminary adjustment, by means of the "Contrast" control, of the actual driving signal applied to the cathode of the cathode ray tube.

Furthermore, when the Picture Monitor is switched to the "Projector" position, its horizontal and vertical sweeps are synchronized directly by pulses obtained from pick-up coils wound into the deflection yoke of the projection cathode ray tube. Since these pulses are actually a measure of the magnetic deflection fields applied to the projection tube, a normal picture on the Picture Monitor is a *positive* indication that the deflection signals applied to the projection tube have the correct frequencies and essentially the correct amplitude.

Fourth and Final Step

All is now ready for the fourth step. Turning the "Picture" switch to "on" lights the fourth amber light, switches the projection tube from cut-off to operating bias, and presents the picture in essentially perfect adjustment.

The cathode ray tube used in this system is rather expensive, and while it is an amazingly tough device when treated properly, it is highly fragile when mistreated. These remarks apply equally well to personnel who operate and maintain the equipment. Conse-

quently, the equipment includes an elaborate system of interlocks and safety devices for protection of both tubes and personnel.

The interlock system prevents the application of primary power to the high-voltage supply unless all doors giving access to the anode and focus voltages are closed. The protection system allows beam energy to reach the tube face only when the following conditions are satisfied:

Requisite Operating Conditions

1. Proper voltage levels exist in the + 800, + 285, - 105 and - 150 volt power supplies.
2. The 80 Kv supply is up to operating level, but not in excess of 82 Kv.
3. Horizontal deflection fields have at least 75% of their normal amplitude.
4. Vertical deflection fields have at least 75% of their normal amplitude.

The protection system is primarily designed to prevent damage to the 7NP4 projection tube, but it also serves to protect the remainder of the system against bias failure.

Throughout the system the protection circuits have been designed to work directly from the critical quantity and not from signals which usually, but not always, denote that quantity. For example, the circuit which protects against sweep failure might work with almost complete safety from various currents or voltages that are readily available in the deflection circuits. Actually, in this case, the critical quantity is the magnetic field in the gap of the deflection yoke. Our protection system includes pick-up coils in the yoke which measure the magnetic fields and thus give positive and complete protection against sweep failure.

In designing the Simplex system we have adopted the goal of providing quality of performance exceeding the requirements of present Tv standards, thus justifying the prediction that the equipment will not be found wanting whenever higher performance standards may be adopted.

[NOTE: GPL solicits through IP any questions relating to construction or operation anent the Simplex system stemming from the foregoing discussion. —ED.]

Your Very Best Buy
BUY U. S. SAVINGS BONDS

Who Invented the Movies?

A stimulating discussion of the contributions of Friese-Greene, British technician, to the cinematographic art, as assayed by two able protagonists in *Films in Review*, official organ of the National Board of Review of Motion Pictures. Terry Romsoye, author of the rebuttal, is a noted film historian and formerly editor of *Motion Picture Herald*.

By GERALD PRATLEY

IT WILL come as a surprise to many moviegoers to learn that William Friese-Greene was the first man to patent a commercially practicable moving picture camera.

While Thomas A. Edison is generally considered by America to be the *inventor of motion pictures*, and France claims Edouard Georges Marey as the *fondateur de cinema*, England considers William Friese-Greene as the *inventor of cinematography*.

The truth is that these three men, and several others in Europe and America, were all working on the then baffling task of trying to photograph and project moving pictures. But whereas Edison and Thomas Armat, Louis Lumiere and Georges Marey, all received wide recognition for their work, the unfortunate Friese-Greene has been ignored, not only abroad but also in his native land.

'The Magic Box' Film

A motion picture about Friese-Greene has just been made in England: *The Magic Box*, based on Ray Allister's fascinating biography, *Friese-Greene—Close Up of an Inventor*.

Friese-Greene was born on September 7, 1855 and died tragically on May 5, 1921. A prophetic and inventive genius, with a gay and vital personality, his life was one of tense struggle against a cunning opposition which sought to use his brains for personal gain. He attained unbelievable success, and experienced heart-breaking failure. During 30 years of hard work he patented over 100 inventions, and longed for the recognition which was denied him.

He died at a trade meeting which had been called to discuss a system known as block-booking. Heated discussion and wrangling were in progress, and Friese-Greene, old and tired, rose with a plea for unity. His voice was almost inaudible; and after he left the speaker's platform he collapsed and died.

Truth or Legend?

Huge, glittering cars rolled up to carry away the men who had grown wealthy on the genius of Friese-Greene. For him the police brought a hand-cart, and carried his body to the mortuary. In his pockets they found a formula for a color filter he

had ordered that morning. And in his purse was all the money he possessed: one shilling and ten pence. At that time it was the price of a cinema seat.

In 1887 Friese-Greene stopped the traffic in Piccadilly by projecting his movie picture of a dancing skeleton onto a shop window. In 1889 he made some of the first films on celluloid, and experimented with synchronized sound. In 1893 he made a color film, and in the years which followed he experimented with chemicals, X-rays, lenses, the electrical transmission of images, stereoscopic films, and much else. The models of his inventions cost him a fortune.

British Film Industry All-Out

Friese-Greene's life contains all the ingredients that are essential for an engrossing, emotional film. And *The Magic Box* is additionally interesting because of the unique way in which it was produced. The entire British film industry co-operated in the most inspiring manner to make this film possible.

A non-profit making company (Festive Film Productions) was formed to produce and distribute this picture. The British Government advanced a loan for a script, and also money for production, with re-payment deferred until after

(Continued on page 38)



Season's Greetings

to the thousands of craftsmen whom we have been privileged to serve with fine cinematic equipment.



C. S. ASHCRAFT MANUFACTURING CO.

36-32 Thirty-eighth St.

Long Island City 1, N. Y.

ARC LAMP SPECIALISTS FOR MORE THAN A QUARTER CENTURY

Greetings from the

OFFICERS and MEMBERS of
LOCAL NO. 678, I. A. T. S. E.

Laredo, Texas

Holiday Greetings

LOCAL NO. 488
I. A. T. S. E.

HARRISBURG

PENNA.

IN THE SPOTLIGHT



By
**HARRY
SHERMAN**

EACH YEAR at this time we are acutely conscious of (and embarrassed by) the desire to acknowledge in mere words our indebtedness to those IA men who by their constancy have made our otherwise feeble efforts an asset to craft progress and general welfare. True, sometimes we felt the urge to lash out at those and that which we felt visited an injustice upon the craft—and we were somewhat on the biting side; at other times we probably were more than lavish in our praise of those who, we felt, were deserving of not only our personal but also of craft commendation.

To those whom we have been privileged to serve in our meagre way by the few notes which were spread upon these pages over the past year, no less than to those whom we may have differed with, or maybe slighted in even the smallest measure, we say—

The Very Best of Everything Now and in the Years to Come

• Radio and television sound-effect technicians of the American Broadcasting Co. chose, *with only one dissenting vote*, the IA as their bargaining agent, replacing NABET, which had represented them until the expiration of their contract October 31 last. The NLRB, in granting the IA's petition for an election, rejected NABET's contention that the sound-effect technicians should be merged into an *existing* unit of engineers.

"The primary function of the sound-effect employees," the Board declared, "is to create sound, other than voice, speech, and music, which is necessary to achieve realism in the production of radio and

television programs. They perform from prepared scripts in front of microphones, as do actors, singers and musicians. The sound-effects personnel constitute a division of the program department, which is concerned with the artistic quality of broadcasts. The engineering department . . . is responsible for the transmission of the artistic effects through the electronic process."

• Pierce Webster, charter member of Buffalo Local 233, won two grand prizes in the 1951 Newspaper National Snapshot contest, in addition to two special cash awards for the other entries. Webster has made amateur photography his hobby for the past few years, but this was the first time he entered a national contest.

• Three members of Local 505, Waltham, Mass.—Herman Lavoie, Norman Bliss, and Arthur Courtemanche—have been placed in the projection room of the drive-in theater opened recently in "Shoppers World," a new shopping center in Framingham, Mass.

• Hye Bossin, managing editor of *Canadian Film Weekly*, published recently the first edition of the Year Book, a comprehensive directory of information on every phase of the industry in Canada. This work reflects painstaking research on the part of Hye and his staff. Congratulations for a fine job.

• Stewart Seifert, Local 203, Easton, Penna., and secretary of the Central Labor Union of Northampton and Warren Counties (Penna.), has been appointed a member of the 14-men Labor group on the Labor Management Committee now being organized in Lehigh (Penna.) Valley. The committee will study, among other things, manpower problems arising from the defense program and recommendations for their solution.

Committeemen were recommended to this second body of its kind in Penna. by the National Labor-Management Policy Committee, with appointments made by U. S. Secretary of Labor Maurice J. Tobin upon the recommendations of D. M. Walker, secretary of the Penna. Dept. of Labor and Industry.

• We were very glad to see our old friend J. E. (Frenchy) Biencourt, Local 78, San Antonio, Texas, on his recent visit to New York. Frenchy and his wife were delighted with the mild N. Y. weather (68° at the time). Note to Frenchy: It's snowing at the moment these lines are written.

• At its regular December meeting, Local 366, Westchester County, N. Y., awarded 30-year membership pins to Charles Bantel, James Maloney, Edward Mascaro, Barney Ostroff, Frank Pilegard, Max Siegel and Joseph Schappach. Under the able leadership of Nat Storch, president, and Joe Monaco, business representative, Local 366 has cemented its reputation as a well-organized IA unit.

• Lou Walters, Local 249, Dallas, Texas, now heads the repair department for the Dallas branch of National Theater Supply Co. He has been associated with NTS for 20 years, 10 of which he managed the Cleveland branch. Lou is very popular with IA men everywhere; he holds a gold life membership card in St. Louis Local 143, and is active in the affairs of the Dallas Local.

• We were always a firm believer in the principle that family differences should

TIFFIN LOCAL 267 HONORS MEMBERS



Diamond-studded IA lapel pins were recently awarded to three members of Local 267, Tiffin, Ohio, for long and loyal service rendered the Local. Shown above (left to right) are the honored members: Henninger, O'Connell, Banks, and at the extreme right is Robert E. Shuff, who made the presentations.

be settled within the family, preferably around the dinner table. Our belief in this principle was strengthened during the past month when we were able to serve, in a small way, a group of swell guys who through their friendship have eased our way through the years.

Our old and good friend, Oscar Neu, president of Neumade Products, was on the West Coast attending the TESMA-TEDA and the SMPTE conventions, when the AF of L Machinists' Union sought to enlist the aid of all IA Locals in support of a strike against the Neumade factory in Buffalo. Naturally, Oscar wasn't available to straighten out the misunderstanding.

A long-distance phone call from Bert Ryde, business representative for IA Local 233, Buffalo, set the conciliatory wheels in motion, with the result that Bert and two representatives of IA Stage Hands Local 10, Buffalo—Danny Gill and Charles (Red) Schaffer—and Floyd Smith, business representative for the Machinists Union (and, of course, yours truly) met with Oscar Neu in New York City. In a few hours a seemingly "impossible" situation was settled amicably.

Our AF of L fellows, Machinists and IA men, made a very fine showing during the conference—and we can say no less for Oscar Neu and Lee Jones of the Neumade Company, and for their attorney, John M. Keating.

• George Schaffer, business representative for Los Angeles Local 150, was successful in organizing two non-union theaters in L. A., and obtained contracts calling for substantial wage increases for the projectionists. Intensive picketing by the Local did the trick.

• John H. Wald, Sr., 52, business representative for the past 22 years of Local 434 Peoria, Ill., died recently after a short illness. He was prominent in Labor and civic circles throughout the State, and his sudden death saddened his many friends.

John served as secretary of the IA 9th District, and at the time of his death was



The late John H. Wald

president of the Peoria Trades and Labor Assembly. He was active in the management and financing of the AF of L Labor Temple in Peoria, and served as manager of the Temple and as secretary of the Temple Association for more than 15 years. In 1938 he established the *Labor Temple News*, official organ of the Peoria Trades and Labor Assembly, and served as its publisher until his resignation last January. He was a member of Temple Lodge 46, AF & AM, and of the Elks Club.

John is survived by his father, John H., of Calif.; a son, John H., Jr.; a daughter, Mrs. Ralph Powell, and five grandchildren.

• New York Lodge No. 1, TMA, held its 87th annual celebration at the Carnival Room, Hotel Capitol, New York, November 17 last. As usual, the party was very well attended by many prominent figures in Labor circles, and, also as usual, it was a grand party—a tribute to Lodge No. 1.

• The 41st biennial convention of the IATSE will be held at the Auditorium, Minneapolis, Minn., the week beginning August 4 next, with official headquarters at the Nicollet Hotel. As usual, Executive Board meetings will be held the week prior to the opening of the convention.

• Congratulations to Local 210, Edmonton, Canada, on its 40th anniversary. The Local celebrated the event several weeks ago at a dinner party which was attended by the entire membership and a number of invited guests.

• This department would somehow seem incomplete at this Holiday season if it

did not include a few words about that good and great friend of all of us who live with and by the process of projecting motion picture film—P. A. McGuire. The term "Better Projection Pays" was coined and broadcast throughout the world by Mac, but it still was just a phrase until he followed through and breathed life and vigor into it. Amityville, Long Island, N. Y., is where Mac resides these days, but this town is far too small to contain his spirit. He belongs to us because he gave us so much of himself. Doff your hats, fellows, to our friend—P. A. McGuire.

P. A. McGuire's "Better Projection Pays" Does Pay

A pioneer projection man merits a bow —and more— from the craft.



• During a short stay in Boston several months ago, we were told by Joe Nuzzolo and Walter Diehl, president and business representative, respectively, of Local 182, that they were approached by several exhibitors who suggested that if the Union would either reduce the manpower in their theaters or take a cut in pay, they would reopen their shuttered houses. The reply of Nuzzolo and Diehl was a flat "No soap," based on the fact that

— 1951 —

Greetings From

MOTION PICTURE PROJECTIONISTS

LOCAL UNION NO. 233

Buffalo, N. Y.

JOHN J. WALSH
President

ALBERT F. RYDE
Business Representative



Greetings to the Craft

CENTURY PROJECTOR CORPORATION

LARRY DAVEE, Sales Manager
NEW YORK, N. Y.

since members of Local 182 did not benefit from the lush theater profits during the past years, they do not feel obligated to take a cut when box-office receipts take a drop.

Although these exhibitors protested their inability to reopen their theaters unless concessions were made by the Local, their cry of "Wolf" fell on deaf ears, and when the theaters *REOPENED* shortly afterwards, it was with the same manpower and pay as formerly.

• Paul L. Ferry, 47, former president of Pittsburgh Local 171, succumbed to a heart attack last month. Paul took an active part in Local 171 affairs, serving on various committees, and for many years was a delegate to IA conventions.

• Local 163, Louisville, Ky., lost three games in the recent AF of L Bowling League contest with Carpenters Local 64. C. Baker, with 500, was high for the winning team, and J. Flaherty, Local 163 business representative, was high for the losing team with 486. Better luck next time.

• Edwin W. Anthony, president for the past 23 years of Local 223, Providence, R. I., died of a lingering illness at the Rhode Island Hospital on Friday, November 23. Edwin served Local 223 continuously since 1928; prior to that he was secretary. He was highly regarded by all who knew him for his many fine qualities.

• When the Aster Theater in Minneapolis, Minn., changed ownership, the new management asked projectionists' Local 219 for a cut in manpower—from a two-man to a one-man shift. A contract with the former owner of the theater, the Minnesota Amusement Co., calling for two-men shifts, plus one relief man, was still in effect when the concession by the new management was asked.

Failing to receive the cut they demanded, the new owners closed the theater. The officials of Local 219 are to be congratulated for their determined stand, as it is a well established fact that once such concessions are granted they set a precedent for further cuts.

• Congratulations to the officials of Local 224, Washington, D. C. on their victory over Washington exhibitors who sought to eliminate the two-man projection room regulation. The appeal of the exhibitors to the D. C. Board of Commissioners to drop this regulation was based on the widespread use of acetate film. This decision makes sense to anybody who knows anything about the motion picture business, because nitrate film will be in circulation in one way or another for many years to come—a fact which is readily admitted by the manufacturers of film stock.

True, the manufacture of nitrate stock

has been discontinued, but there is plenty of it in the laboratories which will be in use for years to come. Also, there are thousands of reissues that are released from time to time, and until such time as these are taken out of circulation or are replaced by prints on acetate stock, the fire hazard in theater projection rooms will never be eliminated.

Ruling of the Commissioners in favor of Local 224 that the two-man regulation be continued, sets an important precedent and will, no doubt, affect the plans of many exhibitors throughout the country who were contemplating similar moves.

• Walter F. Diehl, business representative for Boston Local 182, was appointed by John J. Delmonte, Mass. Commissioner of Labor, to serve on the minimum wage board as employes' representative.

• We were very much interested in a trade press report that United Paramount Theaters had entered into negotiations with the Theater Guild to present a large-screen telecast of the Broadway show, "St. Joan," by George Bernard Shaw, not only in Paramount Theaters but also in other non-competitive theaters that are equipped for large-screen Tv.

Season's Greetings

CLAYTON PRODUCTS CO.
3145 TIBBETT AVENUE
NEW YORK 63, N. Y.

Greetings from

LOCAL NO. 257
I. A. T. S. E.

Ottawa, Ont.

Canada

Holiday Greetings

PROJECTIONISTS
LOCAL NO. 376

Syracuse, N. Y.

Season's Greetings

PROJECTIONISTS LOCAL NO. 173
I. A. T. S. E.

TORONTO, ONT.



CANADA

Eidophor Theater-Tv System

In Which Some Pertinent Questions Are Posed

GLOWING reports bearing on the high degree of efficiency and operating practicability of the Swiss-developed Eidophor theater-Tv system continue to flow from Zurich in the form of "rave" comments by officials of 20th Century-Fox, which has extensive world distribution rights for the system, and other technical personnel who have witnessed Eidophor demonstrations.

Technical personnel of both General Electric Co. and Columbia Broadcasting System have been extremely enthusiastic about the Eidophor system, which attitude is understandable in view of General Electric's deal to manufacture Eidophor equipments here in the United States, and, on the part of CBS, because of 20th Century-Fox's plan to use the CBS mechanical color Tv unit.

Technical data anent the Eidophor system has been hidden under a blanket of secrecy to date; but IP is privileged to present, as a publishing "first," the appended information which is the result of painstaking investigation.

How the Eidophor Works

The Eidophor theater Tv process is understood to work in the following way:

1. An electron beam, much like that in an ordinary Tv picture tube, falls on a thin flat layer of a tacky or viscous fluid.

2. The fluid forms a thin layer which has been spread on a flat circular glass sheet.

3. The glass sheet is rotated around its center under the electron beam, by means of a special motor. Thus the beam constantly strikes new parts of the fluid.

4. Where the electron beam hits the fluid layer, the fluid is heated, expands, and forms slightly raised points or ridges. These ridges thus produce a "picture" in the fluid, in low relief (that is, with small peaks and valleys).

5. As the glass disc rotates, after each "picture" in the fluid has been projected, rollers smooth the fluid layer.

Refrigerating Unit; Illumination

6. The fluid on the glass plate may also be cooled by a refrigerating system connected to the outside of the Eidophor tube.

7. All of the parts aforementioned (except the refrigerating equipment) are within a vacuum tube, and hence are kept at very low pressure.

8. A powerful arc is provided as a light source. Its light passes through a novel and unusual lens system, and special grids, producing what is known as the "schlieren" effect. By means of this effect the light passing through the fluid "picture" is modulated or controlled, and an enlarged picture is thrown on the theater screen.

CBS-Eidophor Color System

The CBS-Eidophor color process is understood to work as follows:

9. When thus used, with the CBS field-sequential method of color Tv, the

Eidophor presumably employs moving color filters which are placed in the arc light beam and driven by means of a synchronous motor.

10. The CBS-Eidophor color system accordingly resembles in a general way the CBS color-Tv system for the home.

Pertinent Technical Questions

The following questions, in relation to the above numbered sections, will naturally occur to the projectionist, the serviceman, and other technicians:

1, 2, 3, 4 above. How easily is an Eidophor picture tube installed, adjusted, and kept in operation? Can the fluid on the rotating glass disc be depended on to stand up under steady and heavy duty? Is adjustment of the "picture" formed in the fluid by the electron beam thoroughly

stable, or is it critical and variable?

5. above. Is the smoothing of the fluid layer a simple and dependable matter? How long is the fluid usable under load?

6, 7 above. How much of a job is the maintenance of the refrigerating system? How long must the refrigerating system be running before the Eidophor tube can be used? Must the refrigerating system be adjusted to take care of average picture brightness, total projection time, or room temperature?

Operating at this low pressure, will the oil vaporize and very quickly contaminate the electron gun by reason of condensation?

Optical System Complexities

8. above. Is the optical system of the Eidophor projector more complex than that in a standard theater film projector? Is it more complex than that in the usual Schmidt theater-Tv projector? Could a projectionist be expected to have the time and skill to keep it clean and in perfect adjustment? In the sooty air of the average city, and in the usual projection room, how often must the optical system be cleaned and adjusted?

5, 6, 7, 8 above. If anything goes wrong in the Eidophor tube itself, or in its accompanying gear and optical system, how long would it take a projectionist, or a serviceman, to fix it? Must Eidophor equipment be available in duplicate for dependable theater operation?

Requisites for Color Pictures

9. above. During the recent color-Tv arguments before the FCC, it was claimed that the CBS color system produced only 40% as much fine detail as

Compliments of the Season

PROJECTIONISTS LOCAL NO. 199

DETROIT

MICHIGAN

Best Wishes for 1952

Holiday Greetings

LOCAL NO. 314

I. A. T. S. E.

SCHENECTADY, N. Y.

Holiday Greetings from the

OFFICERS and MEMBERS

of

LOCAL NO. 396

Binghamton, N. Y.

Season's Greetings

from

LOCAL NO. 273

I. A. T. S. E.

New Haven

Conn.

Holiday Greetings

LOCAL NO. 762

I. A. T. S. E.

San Luis Obispo

Calif.

that available from the opposing simultaneous system. Will this also apply to the CBS-Eidophor theater color-Tv system? And, if so, will not CBS-Eidophor color-Tv networks have to provide a wider frequency band and therefore more costly circuits (which might not be obtainable).

9. above. It also was claimed in the FCC hearings that the CBS system showed flicker, color break-up, and colored action fringes. This was stated to be particularly so unless dim pictures were accepted. Will these effects cause eyestrain, disagreeable color flashes, and colored edges on rapidly-moving objects in the CBS-Eidophor system?

1-9 above. How will the first cost of the Eidophor equipment, compare with that of the competitive RCA, Paramount, General Precision Labs and other systems? And how will the maintenance cost of these systems compare?

It may be assumed that the foregoing and other technical questions will be answered before the Eidophor system is offered for general distribution; they are posed here in the interest of maintaining a balance between unsupported general statements and fact.

Westrex Disc Recorders for 'Voice'

The International Broadcasting Division of the U. S. State Department has completed negotiations with Westrex Corp. to acquire 22 W. E. Type RA-1389 disk recording machines, for use by the "Voice of America" to cut master records from which a number of transcriptions will be made. These transcriptions will be broadcast by transmitters operated by the "Voice" both here and abroad. The recording machines are equipped as complete units with synchronous motors and 33 1/3-78 r.p.m. recorder-holder, 2A lateral recorders, lateral recording equalizers, 5-B amplifiers, and the Davis drive flutter-suppressor.

'Depth of Focus'—Again

Recent reports from Hollywood anent "new" processes and procedures which are warranted to achieve startling photographic effects at no extra cost include, among other aberrations relating to three-dimensional movies and such, that old chestnut anent so-called depth of focus. Such effusions relating to getting something from that which isn't and never was prompt the publication here of a truism which is not subject to change on the basis of mere whim.

Changing the focus of a lens during the exposure is an old procedure. It is worth considering just what happens when the lens focus is shifted, during the exposure, from foreground to background.

When the lens is focused on the foreground, it is self-evident that the foreground is in sharp focus. If the background lies outside of the usual depth of the lens at the stop which is used, it is equally evident that it will be out of focus. The film, which has no particular discrimination or selection ability in itself, will accordingly photograph—or start to photograph—a sharp foreground and a blurred background.

If the lens is now shifted so that the focused zone moves toward the background, the image of the foreground will get progressively softer and more fuzzy, and the image of the background will become increasingly sharper. When the lens is finally focused on the background at the end of the exposure, in this simple case, the background will be in sharp focus but the foreground will be badly blurred.

Picture is Nowhere Sharp

The photographed picture at each distance from the lens will therefore include, first, one sharp but brief component and

an infinite number of increasingly soft and, finally, very fuzzy components. This will hold for *all* distances from the lens. So that the picture will be nowhere sharp.

It is easy enough to increase depth of a lens by spoiling picture quality. But the projected pictures are enlarged hundreds of times on the screen in the theater, and the best lens quality is just good enough for clear and sharp reproduction. Except where soft and foggy effects are deliberately desired in special cases, enlarging very soft film is the wrong way to produce good pictures in the theater.

There is no question that increased depth is highly desirable in motion pictures. But the way to get it is not to start by throwing out the most important characteristic of good pictures, namely, their sharp and clear quality.

Supersonics to the Nth Degree

Supersonic free-air telemetered tests are now carried on at Edwards Air Force Base in Muroc Dry Lake, Calif., where a rocket-propelled sled carries an entire airplane model or component parts faster than sound along a precision track. Radio instruments feed all sorts of data to computers and recorders. Later these data are analyzed for clues to better and faster aircraft.

The free-air track is superior to a wind-tunnel for supersonic research because in free-air there are no confining walls to reflect the shock-wave back to the airplane and so confuse results. Stopping the rocket at the end of the track becomes quite a problem when the rocket travels at speeds equal to a rifle bullet. Engineers constructed a water trough 2000 feet long. A scoop built into the bottom of the test sled dips up water from the trough and gradually slows it to a stop.

What do Researchers Do?

Research labs in the general field devote 10 to 20% of their work to fundamental studies, 40 to 60% to development of new products and processes, 30 to 40% to improvement of existing products and processes, reports J. A. Leermakers, Eastman Kodak Co. Keeping laboratory and company people informed of progress requires continuous informal discussion, making written reports available, and holding two kinds of conferences: (1) Discussions of development work, attended by research, manufacturing, and sometimes sales departments. (2) Meetings of laboratory members to report progress to their fellows.

Best Wishes from

MOVING PICTURE PROJECTIONISTS

LOCAL UNION NO. 181

BALTIMORE, MD.

Holiday Greetings

LOCAL NO. 10

I. A. T. S. E.

Buffalo, N. Y.

Best Wishes

MOVING PICTURE MACHINE

OPERATORS' LOCAL NO. 182

Boston, Mass.

'Fuzzy Frames' in Color Prints

In a letter to Editor R. H. Cricks of the *Ideal Kinema* (London, England), a British projectionist poses a very interesting question anent Technicolor prints. The letter follows:

"A few words as to how Technicolor prints acquire their "fuzzy frames." The enclosed cutting was taken from a . . . trailer which had been stored in a damp box outside. It was damaged by actual drips of water, and the effect in running was that the . . . picture appeared to go out of focus for a brief period every 2 feet or so.

By **ROBERT A. MITCHELL**

NOT mentioned in my articles on color was the mythical phenomenon of moisture causing the "three layers" of emulsion in Technicolor prints expanding in various degrees, thus presumably resulting in mismatch of the Yellow, Cyan, and Magenta images.

This British fellow's trouble is not what he thinks it is. He either has a print which came from the Technicolor plant in defective condition, or else the print he was using suffered a bad case of curl, and hence of focus-drift. The fact that the Technicolor print referred to was a short trailer inclines me to the latter view.

Trailers as a general rule are wound very tightly and with the inner convolution only about an inch in diameter. This makes for severe buckling, particularly when the print is wound up in this manner when brand new, when it is made on acetate stock, and when it has been exposed to moisture, causing the gelatine to expand slightly, thus "setting" the curl in the film.

"Actual drips of water" soaking into the roll of film can conceivably produce very annoying film-buckling—but this has nothing to do with mismatching of the three superimposed images of Technicolor.

Emulsion Same as in B-&-W

The emulsion of Technicolor prints is a single layer of thin bonding gelatine overlaid with the regular silver-containing gelatine emulsion for printing the sound track and frame lines. In short, Technicolor emulsion is *exactly* the same as regular black-and-white emulsion. In printing Technicolor it was formerly the practice to print the colors in this order: Yellow, Magenta, and Cyan. The dyes have a tendency to penetrate to a certain extent the dyes printed first—due to the

* "The Magic of Color," in five installments: IP for May-Sept., 1951, inclusive.

"I suggest that the three layers expand in dampness and shrink in varying degrees on drying out, causing the three images to become mismatched. If the cuttings which you receive from time to time compare with the enclosed, then there can be no doubt as to the cause."

Bearing on this question is the appended commentary by the author of the recently concluded series of articles on color motion pictures which appeared in these columns.*

fact that the dyes are formulated with chemicals having a strong affinity for hardened gelatine—and hence some of the Magenta penetrates the Yellow to give Vermilion-Red, which can be seen by scraping off the outer layer of Cyan.

A few years ago the Magenta and Cyan were transposed in the order of printing, resulting in a bottom layer of Emerald-Green which becomes visible when the outer layer of Magenta is scraped off.

The Cause of 'Fuzziness'

It is true, therefore, that the three separate colors exist in ill-defined layers in Technicolor film; but the total thickness of these layers is probably only slightly greater than the thickness of reduced silver in black-and-white film. The definition of black-and white would therefore suffer almost as much as that of Technicolor if any slippage between top and bottom strata of film emulsion should occur. This, however, is a phenomenon I have yet to find even with water-soaked film. (Remember that all prints are considerably water-soaked between printer and projector.)

Now for the matter of "fuzzy" Technicolor, a condition which bedevils every projectionist at times. It might be thought that the Technicolor printing dyes "run" or spread a trifle in the gelatine of the positive film. They do. When images are printed from brand-new matrices, or printing films having the very sharpest photographic definition, microscopic examinations reveals that the Magenta dye "spreads" only slightly more than the natural graininess of panchromatic negative, the Cyan spreads about two times more than the Magenta, and the Yellow about three or four times more than the Magenta.

In other words, Magenta spreads the least and Yellow the most. But this spreading of the dyes in the gelatine of the positive film is not enough to be visible in the projected picture from even the front seats of the theater. Much more serious are two other causes of fuzzy Technicolor.

First is the matter of actual misalignment of the three color images during printing of a positive in natural color from three separate matrix films. Very rarely does a Technicolor print having poor registration come our way. In fact, most of those we have suffered through were printed in England—especially those carrying in addition to the three color images a fourth superimposed image in silver. The silver image was presumably added to maintain correct spectral balance in low-key scenes. However successful it may have been in this regard, it sure ruined the focus. G. B. Shaw's "Cleopatra" is a horrible example.

Printing From Worn Matrices

Next comes the most serious defect of all—printing from matrix films which

Season's Greetings

**MOVING PICTURE PROJECTIONISTS
LOCAL NO. 486 I. A. T. S. E.
Hartford, Conn.**

Season's Greetings

**from
PROJECTIONISTS
LOCAL NO. 521
Long Beach, Calif.**

Holiday Greetings

**PROJECTIONISTS LOCAL NO. 650
Westchester County
New York**

Season's Greetings

**from
LOCAL NO. 414
Wichita, Kans.**

have exceeded their useful printing life. In the old days it was possible to get about 50 prints from each set of matrices. For more prints new sets of matrices had to be prepared from the original negatives. The dye-soaked relief images of matrix films seem to get fuzzier and fuzzier as more and more prints are made from them. Naturally, a worn-out set of matrices produces a print so blurry as to annoy even patrons in the back rows.

It is no secret that Technicolor does not have such sharp images as the best black-and-white prints; but the process is being improved constantly. In its present state of perfection (in the United States at least) it often outstrips black-and-white in the matter of sharp images. On the whole, Technicolor is eminently satisfactory and well-managed here. Patrons never complain about Technicolor quality, whereas squawks sometimes arise as to the graininess, fuzziness, lack of good contrast, etc., of black-and-white prints.

Trad Theater Tv—Motiograph

Motiograph, Inc., manufacturers of quality 35- and 16-mm sound projection equipment, is sponsoring an all-out promotional campaign to acquaint the theater field with the merits of the TRAD direct-projection theater Tv system. An elaborate booklet in color which gives not only the technical low-down but also the transcontinental relay facilities available to potential users has been sent to every theater in the U. S. and Canada.

The TRAD system is the lowest-priced in the theater Tv sweepstakes, its price of \$8,950 including a one-year guarantee against failure of any component subject to normal usage. Motiograph states that full details of the TRAD system will be made available shortly, with particular emphasis being placed on the design and operational features which apply directly to the projectionist.

Projection Men Named SMPTE Fellows

Projection field notables who have been named Fellows of the SMPTE are Clarence S. Ashcraft, of the lamp manufacturing firm of the same name; Bill DeVry, president and E. W. D'Arcy, chief engineer, of the DeVry Corp., and Ed Stifle, of Eastman Kodak film department.

NPA Conservation Appeal

Under the general heading "Conservation of Film and Equipment is Urgent!" the National Production Authority has mailed to thousands of projection rooms an attractive colored folder urging conservation on all fronts. Excerpts from the folder are appended hereto.

The disregard of proper maintenance has been resulting in excessive damage to film and excessive demands for replacement parts.

REMEMBER—Projectors are made of critically needed materials. They MUST be properly maintained and serviced FREQUENTLY. Neglect results in needless waste, poor projection, audience hazard, and expensive film damage.

YOU CAN HELP REDUCE THIS WASTE!

Use the following checklist. It's for your own protection!

CHECK—

Sprockets frequently. Hooked sprockets, undercutting of teeth, and tooth breakage destroy film.

Tension springs, film guides and strip-pers for wear.

Take-up and feed tensions for proper adjustment.

Magazine rollers for wear. Jamming is common when they are neglected.

Bearings, gear trains, and other precision-made parts.

Keep all moving parts lubricated properly.

CLEAN—

UPPER MAGAZINE, fire trap, and rollers. Remove all dust, film fragments, excess oil.

PROJECTOR HEAD. Remove dust, film residue, oil drippings. Make sure that rollers and gate and tension shoes are thoroughly clean.

OPTICAL SYSTEM. Get the lenses clean and in proper alignment.

SOUND HEAD. Be sure it is immaculate throughout.

LOWER MAGAZINE, fire trap, and rollers. Remove all dust, film fragments, excess oil.

LAMP HOUSES. Their neglect is an inexcusable source of trouble and waste. Clean reflectors, condensers, rails, worms, gear tracks, lugs, and carbon holders. *Take out drippings and put them in your special container for salvage.*

START USING THIS CHECKLIST TODAY! THEN KEEP ON USING IT!

Pulse Rates and Death Rates

By DR. M. H. MANSON

Medical Director, Amer. Tel & Tel.

When a pretty nurse takes a man's pulse, chances are the patient is more interested in her big blue eyes than in his pulse rate. Few people think that a "fast" or "slow" pulse is of any great importance. Actually, as the speedometer which indicates how fast your heart is working, your pulse beat is something to watch pretty carefully.

At Johns Hopkins University in Baltimore. Dr. Raymond Pearl has discovered through study of thousands of pulse records that there is a definite re-

lationship between pulse rate and length of life. Long-lived persons averaged two fewer heart beats a minute than shortlived persons. The healthy heart in an adult pumps about 70 times a minute, producing a pulse rate of 70 beats a minute. This adds up to 4,200 beats an hour, 100,800 a day, 36,792,000 a year. Nine to ten tons of blood go through the blood vessels, day in and day out.

Although you can't give the heart a full-time vacation, you can do much to ease its load. Suppose, for example, you cut down on your daily pace enough to save the heart two beats a minute over a year's time. This would actually give your heart the equivalent of a ten-day vacation. And a good night's sleep—eight hours—will save about 7,000 beats a day.

• Out-of-town visitors to IP officers: H. Paul Shay, Local 289, Elmira, N. Y., and secretary of the 10th District; Stewart Seifert, Local 203, Easton, Penna., and J. E. (Frenchy) Biencourt, business representative for San Antonio Local 78.

Season's Greetings

LOCAL NO. 337

I. A. T. S. E.

UTICA

NEW YORK

— Greetings —

LOCAL NO. 224

I. A. T. S. E.

WASHINGTON

D. C.

Movies Out of Doghouse, Says Big Biz Organ

FROM *Business Week*, that most competent observer of and reporter on the travails of *big business*, is culled the appended commentary on the economic health of the movie industry (*circa* Nov. 15 this year). One should bear in mind that the editors of this continuing compendium of men, money and affairs are people of sharp perception whose ears are attuned to the emanations from lower Manhattan—Wall Street, to be specific. Here's how they see it:

The jingling at Hollywood's box-office has caught Wall Street's ear. Movie attendance, which started picking up this summer, has leveled off at an encouraging figure, despite the return of the top Tv shows to provide competition. In recent weeks, quite a few brokerage houses have put out special market letters, suggesting that their customers should think seriously about buying the movie shares as a good speculation.

The argument runs like this: movie shares appear undervalued, compared with the market as a whole. Many of them yield from 8 to 10%. Dividends will be maintained, because higher box-office receipts and strict attention to cost-cutting make it almost certain that second-half earnings will be better than the mediocre figures reported earlier this year.

Hollywood Turns the Corner?

This means—so the argument goes—that Hollywood has turned the corner. It has adjusted itself to Tv. According to the optimists, the two industries eventually will enter into a profitable marriage. Some movie men think they may be able to use their lots to make Tv films, and old films carried on the books at little or nothing will bring in new revenue from Tv.

Analysts who are bullish on the movies go on to argue that people are now pretty well supplied with the durable goods they needed after World War II. From here on, they'll be able to spend more on nondurables, including movie tickets. They'll be tempted to spend more on movies, because Hollywood is making better pictures.

A lot of people who know Hollywood well refuse to believe that the major studios can make a cost-cutting program stick. Reports are that costs have been reduced from 25% to 33% below 1947. But there's an old saying that when the devil is sick he gets religion. If Hollywood has a string of successful pictures, will it continue to hold the line on costs?

Hollywood's 'Normal' Audience

Even if Hollywood does keep costs down that might not be enough. After all, nobody can be sure yet what Hollywood's "normal" weekly U. S. audience is going to be. According to the best available count, it rose to a peak of 80-million weekly in 1946, gradually dropped to as low as 53-million last spring, and has now leveled off at around 57-million or 58-million. Perhaps Hollywood may not be able to hang on to this 58-million.

Finally, suppose the movie makers do increase their profits? You can be sure that



when you use
SUPER-SNAPLITE

f/1.9 projection lenses

Yes "MOVIES ARE BETTER" and they're "BETTER THAN EVER" if you use Super Snaplite f/1.9 Projection Lenses. These superb lenses give you maximum light, maximum sharpness, and maximum contrast . . . maximum viewing satisfaction for your patrons.

True speed of f/1.9 in every focal length up to 7 inches.
Ask for Bulletins 207 and 209.



"You Get More Light with Super Snaplite"

KOLLMORGEN

2 Franklin Avenue
Brooklyn 11, New York

Optical CORPORATION

the movie unions, as well-organized as any in the U. S., are going to demand a share of the take for their members.

Nearly as important as the cost-cutting program are the prospects of increased remittances from overseas. In prewar days, the movie makers used to say that the U. S. box-office paid for their costs, and the foreign box-office provided the profits. Lately, the companies have been getting larger remittances from overseas than previously.

The catch is: What will happen if the British, French, and other currencies go on weakening, as they have lately? You can

expect that authorities abroad will slap on new restrictions to prevent loss of dollars.

Movie-Tv Nuptials

Furthermore, the coming marriage between Hollywood and Tv, though probably written in the stars, is still in the courting stage. The FCC might call it off, though chances are that it will be indulgent. FCC is scheduled to start hearings Jan. 15 on the proposed merger of American Broadcasting Co. with United Paramount.

There are a lot of other problems to be cleared up. When they have been solved, the

movie business may be quite different from what it is now. The marriage with Tv may be profitable to some segments of the movie business. But it won't be profitable for all. For one thing, many of the smaller movie houses may disappear, forced out by big theaters with expensive large-screen and other features and by drive-ins.

Subscription-Tv Factor

For another, the \$1-million-plus features made by Hollywood are scarcely suitable for home Tv as we know it today, unless sponsors can be found who will pay huge fees for a few minutes of commercial. That's not likely; so some kind of subscription Tv must be developed. Assuming that, later on, the "normal" Tv count will be 20 or 25 million sets, how many set owners can be relied on to pay 50c or \$1 to see a new picture—once the novelty has worn off—when they can see older ones for nothing? If subscription Tv is financially successful, what will that do to the exhibitors?

Suppose the movie makers—or some of them—release their films to Tv not just the ancient ones, but films only a few years old? Won't that hurt their attempts to push subscription Tv? Can both approaches be profitable?

Legal obstacles have already popped up on the use of old films on Tv. Roy Rogers has secured an injunction forbidding Republic to lease his old films to Tv, though the case has been appealed. Gene Autry is filing a similar suit.

'Independents' on Their Own

All these problems could lead to something like this: The major studios, made top-heavy by their overhead, might be supplanted by independent producers who rent the big studios to make Class A films for, say, \$100,000 to \$150,000. They would have a lot more elbow-room in regard to subscription Tv and movie theaters. That is, they could make a profit on much smaller box-office receipts. The small studios might also develop along this line.

Or if subscription Tv doesn't succeed, some of the smaller movie-makers—and perhaps big ones, too—could perhaps eke out by making a big volume of half-hour or other short Tv films on low budgets, say \$25,000. They might not make money on this, except in the sense that it cut their overhead on wasted studio space and unused time of salaried personnel. Perhaps they could help build up their own stars this way.

In this direction, Decca Records and Universal Pictures have merged. The main reason must be Tv. Universal has a subsidiary that has been making 16-mm home movies. Decca has 48 franchised agencies around the country that distribute Decca records. The subsidiary could make short films for Tv, and the agencies could sell them to local stations.

GPL 'Videofilm' for Gary, Indiana

Palace Theater, Gary, Ind., (2200 seats) will be the first Y. & W. Management Corp. house to theater Tv. General Precision Labs, through National Theater Supply, will install a "Videofilm" system which is expected to be in operation before year's end. Gary

Better Picture!
Clearer Picture!
Sharper Picture!

See the **New**

WALKER
PM*
"HIGH INTENSITY"
SCREENS

NATIONAL
THEATRE SUPPLY
Division of National • Simplex • Bludworth, Inc.

Ask Your National Man!

* PLASTIC MOLDED

LOOK TO **WENZEL**
for the Finest in Projector Equipment



Closed Sound Head—WSH-3

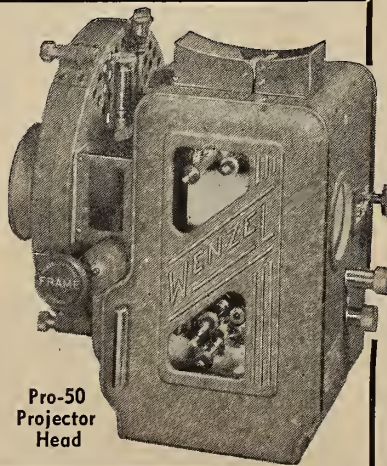

Pro-50
Projector
Head

WENZEL PROJECTOR CO.
2505-19 S. State St. Chicago 16, Ill.

has no Tv station, but being in the Chicago home set area, the Palace will hook into the main coaxial feeding Chicago.

Projection throw will be 125 feet, with a 46-amp arc projector pouring 4200 lumens through the 16-mm film.

IA ELECTIONS

LOCAL 150, LOS ANGELES, CALIF.

John Maynard, *pres.*; Geo. J. Schaffer, *bus. rep.*; Chas. A. Vencill, *sec.-treas.*; Harold Angel, H. Clay Blanchett, Frank C. Champlin, Claire C. Piper, Hugh C. Smith, *exec. board*; Manuel Portillo, *guide*; Virgil Crowell, Hans (Deak) Freyman, E. J. (Red) Schmidt, *exam. board*; Duane E. Adams, Henry J. Kearney, Ray Richards, *trustees*; Magnus Nielsen, Clyde W. Shuey, Ralph L. MacDonald, J. Maynard, Wallace G. Crowley, Paul J. Mahoney, G. J. Schaffer, and C. A. Vencill, *del. to IA convention*. Elected to the *board of directors, Local 150 Club, Inc.*: Frank McBryde, G. J. Schaffer, C. W. Shuey, Leo F. Stockwell, C. A. Vencill, H. Angel, J. Maynard, Hugh C. Smith, H. C. Blanchett, R. L. MacDonald, P. J. Mahoney, and M. Nielsen.

LOCAL 173, TORONTO, ONT., CANADA

Jimmy Sturgess, *pres.*; Lou Lodge, *vice-pres.*; George Jones, *sec.-treas.*; Pat Travers, *rec.-sec.*; Wm. Covert, *bus. rep.*; Roy O'Connor, Arthur Milligan, Jack Hills, Norman Tanner, *exec. board*; Douglas Cameron, Bill Reeves, Jackie Harris, *trustees*; George Robinson, *tyler*; Solly Cohen, *sgt.-at-arms*; J. Sturgess, P. Travers, A. Milligan, N. Tanner, *del. to IA Convention*.

LOCAL 181, BALTIMORE, MD.

Sam Isaacson, *pres.*; Louis Sieber, George Matthews, Wilbur George, *vice-pres.*; Chester Towers, *rec.-sec.*; Tom Finn, *fin.-sec.*; Carroll Bayne, *bus. rep.*; William Lang, Jr., F. W. Fadum, Charles Grauling, *trustees*.

LOCAL 440, ST. JOHN, N. B., CANADA

Edmund A. Chase, *pres.*; Roy F. Burnett, *vice-pres.*; James A. Whitebone, *general sec. and bus. rep.*; Cecil D. Beesley, *rec.-sec.*; Alyere T. Wedge, *treas.*; Leslie A. Sprague, Rennie J. Foulds, Norman A. Peters, *trustees and auditors*; J. Whitebone, A. Wedge, J. Vincent Mudge and Louis E. Comeau, *del. to Trades and Labor Council*.

LOCAL 623, WEST PALM BEACH, FLA.

C. W. Crow, *pres.*; J. M. Bursey, *vice-pres.*; C. C. Dodds, *rec.-sec.*; E. H. Hite, *bus. rep.*; S. E. Bursey, *fin. sec. and treas.*; P. I. Truax, *sgt.-at-arms*; L. T. Crick, J. W. Cummings and E. H. Hite, *trustees*; R. J. Allison, J. C. Crawford, *del. Central Labor Union*.

AnSCO Monthly 'Abstract' Bulletin

Originally intended solely for use by the company's research department, up-to-date information on photographic technical developments, literature references, new literature and new patents, is being published by AnSCO, Binghamton, N. Y. "AnSCO Abstracts," a monthly review of technical literature, is produced in mimeographed form

RCA Service protects your Box-Office

—By guarding
the HEART
of your Theatre



PROJECTION... SOUND

... AND RCA SERVICE

It costs so little to protect so much

The advantages of RCA Service are yours at a cost so low, a few admissions daily pay for it. Write for complete information.



Sound and projection equipment (*the heart of your theatre*) will wear out through continuous performance, unless the equipment is protected by periodic checkups and preventive maintenance.

Guard your equipment . . . protect your box-office with *complete* RCA Service Coverage. RCA Service is more important today than ever before.

The possible scarcity of new sound and projection equipment . . . even replacement parts . . . makes it important that you protect the life of the equipment you now have. Coming events may require you to keep your equipment in operation for a much longer period than you plan. Prepare now for the future while replacement units are still available.

RCA Parts Plans cover all makes and types of theatre sound equipment, as well as projectors and accessory units. RCA Service protection is more vital today than ever before.



RCA SERVICE COMPANY, INC.

**A RADIO CORPORATION of AMERICA SUBSIDIARY
CAMDEN, NEW JERSEY**

CLAYTON BALL-BEARING EVEN TENSION TAKE-UPS

For all projectors and sound equipments

All take-ups wind film on 2, 4 and 5 inch hub reels.
Silent Chain Drives

THE CLAYTON REWINDER

For perfect rewinding on 2000-foot reels.

CLAYTON PRODUCTS CO.

31-45 Tibbett Avenue

New York 63, N. Y.

to permit inclusion of the latest information—often as close as a few days after it becomes available.

Obtainable for \$5 per year (outside the U. S. and Canada for \$8) Ansco Abstracts, now in its 11th year, covers the various aspects of photography, including physics, chemistry, graphic arts, purely photographic items, applications of photographic principles in Tv radiography, medicine, etc. Pat-

ents are listed and reviewed in a separate section.

For additional information or subscriptions, address Library, Research Dept., Ansco, Binghamton, N. Y.

139,500 MPS—Believe it or Not

New technique developed by J. H. Park of the National Bureau of Standards increases "writing speed" of a high-voltage

oscillograph to three-fourths the velocity of light. High intensification of the electron beam is obtained momentarily by superposing a steeply rising voltage pulse on the steady voltage applied to the discharge tube of the oscillograph.

The resultant increase in the intensity of the trace makes writing speeds up to 9100 inches per microsecond easily visible! These high writing speeds can be used to study rapidly varying electrical surges, such as are caused by lightning discharges, and to learn more about the insulation breakdown the surges produce.

Sic Semper Electronics!

Transistor development will be worth watching, as pregnant of big things for the future. There have been recent secret showings of this improved device to the Military. All laboratories are eager for inside info from the Bell Laboratories group doing transistor pioneering. Why? Because this little device could, in the years to come, spell the demise of the vacuum tube and transformation of the multi-billion dollar industry which has been built up around electrons in vacuo. *Sic semper electronics!*

ANSWER TO YOUR TECHNICAL PROBLEMS...

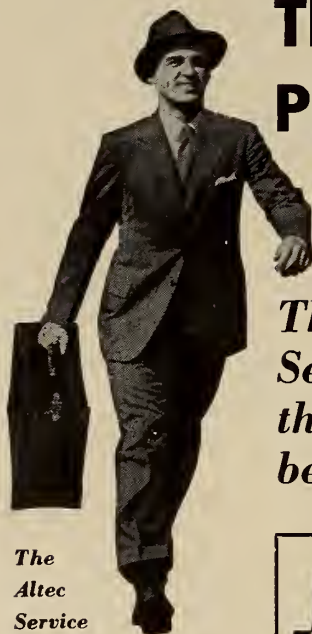

The
Altec
Service
Man

*The Altec
Service Man and
the organization
behind him*



161 Sixth Avenue,
New York 13, N. Y.

PROTECTING THE THEATRE—FIRST PLACE IN ENTERTAINMENT

WHO INVENTED MOVIES?

(Continued from page 27)

other investors have been repaid. Everyone working on the film—from artists to technicians—has deferred part of his salary or given his services free. The cast reads like a theatrical *Who's Who*.

The Film's 'Objective Outlook'

Although the cost of this Technicolor picture will nevertheless be about \$900,000, all the cash that was required was less than \$500,000. The Associated British Film Co. made studio space available on deferred operating costs. Technicolor and Kodak deferred 50% of their charges. British Lion will distribute at extremely low cost. All the major circuits will share the film.

In *The Magic Box* Britain seeks only to record the achievements of a sadly neglected scientist whose contributions furthered the phenomenal progress of motion pictures throughout the world. There is no desire to minimize the accomplishments of other cinema pioneers who worked in other countries. In order to

REEL-END ALARMS

Jackson's Patd. Automatic!
Can't Scratch Film! Foolproof!
Lasts a Lifetime! \$18.50 per pair
On Money Back Guarantee

Order one from your dealer or write to
American Theatre Supply Co., Inc.
2300 First Ave., Seattle 1, Wash.

NEVER HAS
Economy
BEEN SO
ESSENTIAL AS NOW!

THERE IS A LORRAINE CARBON TAILORED FOR
YOUR SPECIFIC PROJECTION REQUIREMENT

Send necessary projection equipment
data to guide us in recommending the
Lorraine Carbons that will do your
theatre or drive-in projection job better
and More Economically.

SLOW BURNING
SAVINGS IN POWER CONSUMPTION
SAVINGS IN MAINTENANCE

ECONOMIZE

WITH *Lorraine
Carbons*

Lorraine CARBONS, INC., BOONTON, N. J.

BUY U. S. DEFENSE BONDS

maintain an objective outlook, the opening titles of *The Magic Box* are filmed against the statues of Edison and Marey.

FRIESE-GREENE A LEGEND In Which Informed Britons Do Not Believe

By TERRY RAMSAYE

SINCE I seem unintentionally to have created some international tension by my remarks about *The Magic Box* and its hero, William Friese-Greene, I avail myself of the opportunity to explain my real intention.

The publicity for *The Magic Box* clearly represented it as a film biography of William Friese-Greene and purported to establish him as the father of the cinema, and Britain as its homeland. Obviously, it was all a part of the brave, proud British Festival now being held in London.

SAVE CARBONS & COPPER! "PHILLIPS" CARBON SAVERS Machined and Handmade



Ask Your THEATRE SUPPLY DEALER

*So much more
than Gears...*

THESE
SUPER
LaVezzi
SERVICE
GEARS!

They are the ultimate in precision manufacture—made by highly skilled operators using newest, most modern equipment. *Identical*, completely interchangeable—they save time, trouble, expense, assure smoother operation and better pictures.

LAVEZZI MACHINE WORKS
4635 WEST LAKE STREET
CHICAGO 44, ILLINOIS



I merely said in print that neither contention was supported by the facts—a conclusion I reached, and published, about 25 years ago.

Claims Unsupported by Facts

Some of the facts: William Green, a portrait photographer, was a smiling, friendly and amiable fellow, untutored in the sciences, given to fancies, beset by ambitions. When he married a Swiss lady, he sought escape from the commonplace by hyphenating her name to his and adding a decorative "e" to his Green. He had a genial picture gallery manner and spoke with warm plausibility. He probably believed in his claims.

Friese-Greene 'Unimportant'

At the request of the Society of Motion Picture and Television Engineers, I reviewed *Friese-Greene: Closeup of an Inventor*, by Ray Allister, which is the source document for *The Magic Box*, in its *Journal* for April 1949. In the course of the review I observed:

"... Mr. Friese-Greene is credited [in this volume] with the original concept of principles recorded and demonstrated long antecedent to his advent, including the work of Baron Franz von Uchatius, Louis Ducos du Haroun, Coleman Sellers and Henry R. Heyl of Philadelphia, and many another. His alleged and so-called prior presentations were not reductions to practise or demonstration of anything beyond the devices and methods of years before. . . ."

His American Foray

I might have gone into the intricate history of the optics and mechanics of the early art, but so unimportant a figure as

Friese-Greene didn't seem to warrant doing so.

No British reader rose to complain at that time.

During the war conducted many years



**You Can't Buy
A GOOD
Rectifier
for Less!**

Strong Rectifiers are the only rectifiers on the market which are especially designed, manufactured and tested in one plant together with and for use with motion picture projection arc lamps. This is highly important, as efficient operation of each type and rating of arc necessitates a rectifier specifically engineered to its particular requirements.

There is a dependable Strong Rectifier for every type projection lamp: 2-Tube • 4-Tube • 6-Tube • Single and Three Phase Models for

- Rotating Feed Angular Trim High Intensity
- Copper Coated Coaxial High Intensity
- 1 K.W. High Intensity
- Low Intensity

All assure smooth output current, long life, low operating temperature, and flexibility in control.

WRITE FOR LITERATURE OR FREE DEMONSTRATION

THE STRONG ELECTRIC CORP.
CITY PARK AVE. TOLEDO 2, OHIO
PROJECTION LAMPS
SPOTLIGHTS • RECTIFIERS • REFLECTORS

A GOOD FILM CEMENT MAKES A GOOD SPLICE

Use ETHYLOID Double - Action Film Cement and you use the BEST!

- ETHYLOID makes hard-to-splice safety film EASY
- ETHYLOID works FASTER—HOLDS and DOES NOT CONGEAL

The Proof is in the Test

IA PROJECTIONIST LOCALS: Have your secretary advise us the number of theatres in your jurisdiction and we will gladly send you one small test sample of ETHYLOID FILM CEMENT for each theatre.

Manufactured in U. S. A. by

FISHER MANUFACTURING CO., Manufacturing Chemists
1 Salter Place
Rochester 13, N. Y.

ago against the Motion Picture Patents Co. by the "Independents," Friese-Greene was brought to this country to testify as

PROJECTIONISTS ALREADY HAVE TROUBLE ENOUGH

When a projectionist presses the button to open the curtain and get the show underway, he expects the curtain to open—and so does the boss.

Failure of the curtain control equipment at that critical point sends blood pressure zooming, clips many a useful year from the projectionist's life. It also sends spectators' blood pressure skyward, clips many a dollar from the box office take.

Wise projectionists avoid all these difficulties by recommending to the boss that he install Vallen curtain controls, tracks and special operating devices. They've been answering projectionists' demands "on the button" for 35 years, because they're precision-engineered to do their job.

Put a Vallen catalog in the front office now. Just drop a note, asking for a new catalog, to VALLEN, INC., Akron 4, Ohio.

to his claims of priority. One of these "Independents" was Universal, and a man personally concerned in that company—P. A. Powers—told me that Friese-Greene arrived with nothing to support his claims, and that the "Independents" did not dare to offer him in court.

He sailed for home, to tell there tales of intimidation, including the assertion that he had heard threats to toss him off Brooklyn Bridge. He was, indeed, an uninhibited inventor.

Since then the curious assertion has circulated in Britain, and occasionally even in this country, that the United States courts broke up the Patents Co. by declaring for Friese-Greene's priority. There is no substantiation whatever for this. I have repeatedly demanded that the case and decision be cited. Expert patent lawyers know of nothing even approximating such a decision.

Cites a British Opinion

My London challengers hurl at me the statement that the technical consultant for *The Magic Box* is the able British authority R. Howard Cricks, the expert on technical matters for the competent *Kinematograph Weekly*, of London. My critics, however, do not reveal, as I have done elsewhere, that the *Kinematograph Weekly* for June 1, 1950, in answering some Russian claims of film priority, published a report from Mr. Cricks in the course of which Cricks said incidentally, but flatly, that Friese-Greene was not an important figure in the history of the cinema. The *Kinematograph Weekly* said in its report:

"In summarizing his evidence, Cricks admits that William Friese-Greene's contributions . . . are not very important. He considers that Edison, Paul and Lumiere played a far more important part."

Long ago I obtained from Robert W. Paul, of London, and Louis Lumiere, of Lyon, France, their personal stories. Both declared that their efforts had been based on the Edison Kinetoscope.

Patents Merely Claims on Paper

Much is made in the British claims about the many patents that Mr. Friese-Greene "took out." That means claims on



THE PRACTICE OF THROWING AWAY CARBON STUBS IS PROBABLY COSTING YOU THOUSANDS OF DOLLARS

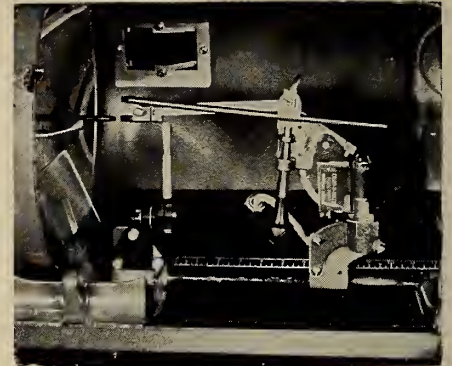

THE CRON-O-MATIC Fully Automatic CARBON SAVER

uses stubs of all lengths without any preparation. It's no longer necessary to guess whether or not a carbon stub will burn a full reel. No matter how short it may be, simply insert in the holder. When it is entirely consumed, the new carbon goes into use without losing the light. It in no way interferes with the regular operation of the lamp.

Adaptable to Ashcraft "D", Brenkert-Enarc, Peerless Magnarc and Strong Mogul lamps. Only \$52.50.

PAYS FOR ITSELF 3 TIMES A YEAR!

Burns positive carbon stubs, which usually average 3 1/4" in length, down to a constant length of 3/4", to result in a net saving of 2 1/2" per carbon or 22.2% of the cost of the carbon, which for the average theatre actually amounts to \$150.00 per month . . . every month!

If your dealer cannot supply you, order direct.

Dealer Inquiries Invited

PAYNE PRODUCTS CO. (Cron-O-Matic Division)
 2454 W. Stadium Blvd. Ann Arbor, Mich.
 Please send literature on the Cron-O-Matic
 Please ship Cron-O-Matic Carbon Saver
 C. O. D., including postage
 Remittance herewith.

Name _____
 Theatre _____
 Street _____
 City & State _____
 EXPORT: Frazar & Hansen, Ltd.
 San Francisco, New York, Los Angeles

ONLY Century PROJECTORS HAVE EVERYTHING

4-inch diam. lens mount
 Water-cooled apertures
 Oil-less Bearings

CENTURY'S high-efficiency projector with the NEW 4-inch diam. lens provides pictures of increased brightness and appeal—for even the largest drive-in screens.

CENTURY'S water-cooled aperture gives as much light with a 90 ampere arc as other projectors using a 180 ampere arc and heat filters!—Reduce power cost—Get sharper pictures—Save film.

CENTURY'S sealed, oil-less bearings and glass-hard gears reduce maintenance costs. No oil sprays or baths to mess up film or projection room.

You can SEE and HEAR the difference!

CENTURY PROJECTION AND SOUND SYSTEMS
 See your dealer or write for information

CENTURY PROJECTOR CORPORATION
 New York, N. Y.

Season's Greetings

NEW YORK STATE ASSOCIATION
of
MOTION PICTURE PROJECTIONISTS

Charles F. Wheeler, Sec.-Treas.

Peace on Earth—
Good Will to Men

LOCAL NO. 253

Rochester, N. Y.

paper, not working, or even workable, machines. For instance: Friese-Greene "took out" a patent on the making and projection of stereoscopic pictures without a viewing device. He never did know the nature of stereoscopic vision, and he never demonstrated any such device.

Since the assault on me first began in Britain, the broad claims of Friese-Greene's fatherhood of the art have been importantly modified. The publicity agents now say they want merely to establish that Friese-Greene was an important worker in the field. That's a concession, but it is not enough.

Sentimental tinkering with the history of the motion picture in a motion picture is inexcusable. It has been my fate to spend a considerable part of an industrious life trying to clear the annals of the motion picture of their myths, misrepresentations and confusions. Those who have had a hand in *The Magic Box* have been motivated by laudable patriotic purposes, but these, alas, the serious historian cannot approve.

Dramatic Ending Spurs Legend

The career of Friese-Greene came to a dramatic end, which gave impetus to the legend of a great inventor dying unrewarded. Every industry has such a legend

Friese-Greene was living in penury in an attic room in London, still pathetically striving to invent. He decided to attend a general meeting of the cinema trade to discuss block-booking, about which Lord Beaverbrook was then campaigning. It is doubtful that he was invited to attend.

The meeting was stormy. When Friese-Greene rose to speak he faltered and

mumbled. He was invited to the front of the hall, and there stood swaying, speaking in broken sentences and incoherence. He was helped down the aisle to his chair. He sat down, buried his face in his hands, and died.

The daily papers played it tremolo, using all the stops, and the legend was on its way.

Merely an 'Ingenious Mechanic'

Meanwhile, according to Mr. Allister's biography: "... the *British Journal of Photography* spoke of Friese-Greene as merely an 'ingenious mechanic' with 'a very hazy notion of the fundamental principles of chemistry and physics.' But then photographers had never loved Friese-Greene."

The fact that the British government is scheduled to pay £100,000 of the estimated total cost of £220,000 of *The Magic Box*, has political significance. *The Magic Box* certainly doesn't contribute to the glory of the Empire, nor to the art of the

motion picture. Britain's history is too full of real achievements for the fanciful story of Friese-Greene to be exploited at Government expense at the British Festival.

Lest it be held that I am burdened with certain prejudices, as has been hinted, let me set down that I am of Norman-Scot extraction and have ever been aware of Britain's greatness and conscious of its role in the nurture of our civilization. Hence I would not deflate the sentimental claims made for Friese-Greene because of anti-British prejudices, but for the sake of the record.



• The NEW, improved, positive method of permanently patching all types and makes of film—8mm., 16mm., 35mm., Trucolor, Technicolor, Kodachrome, Nitrate and Safety Film.



Used and endorsed by Projectionists in countless theaters.

specifically for lasting Patches.

ESSANNAY ELECTRIC MANUFACTURING CO.
1438 North Clark Street Chicago 10, Illinois

Season's Greetings From

MOVING PICTURE MACHINE OPERATORS UNION

LOCAL NO. 162, I. A. T. S. E.

SAN FRANCISCO, CALIF.

THE OPERATORS' FAVORITE!



Galde's Automatic Enclosed Rewind Always Works! Silent, safe, U.L. approved! Eliminates fire hazard. Positive friction... can't clinch film. Tilt-back case... reels can't fly off. Microswitch safety cut-off... when door opens or film breaks, motor stops!

AT BETTER THEATRE SUPPLY DEALERS
GOLDE MANUFACTURING COMPANY
DEPT. IP. 1220 W. MADISON ST. • CHICAGO 7, ILL.

Season's Greetings

from the

OFFICERS and MEMBERS of
LOCAL No. 715, I. A. T. S. E.

Gainesville

Texas

PROJECTIONIST SHOWMANSHIP

(Continued from page 8)

most common trouble is faulty burning of the arc. Close attention to the operation of the lamp, even if it be a modern automatic-control model, is mandatory. A positive crater burned slantwise causes uneven and discolored screen illumination; too long an arc-gap causes the light to flicker and risks loss of illumination; too short a gap causes poor illumination, spindling of the carbons, and even risks cracking the mirror, as will now be explained.

But first a word about carbons. Don't store carbons in damp places. Carbons are porous and absorb moisture readily. A damp trim gives an extremely poor performance. Many times an unsteady and sputtering arc has been blamed on "a poor lot of carbons," when, actually, the carbons would burn excellently if only they were dried out before use. It is always a good idea to place a trim of carbons in or under the lamphouse, if there is room, and thus be sure of having a dry trim on hand. On the so-called "victory" carbons the copper coating is not thick enough to stand full current capacity. A few more wars, and we shall have no copper at all.

At first thought, there seems to be little connection between a short arc gap in a high-intensity lamp and a damaged mirror, but it is a fact that cracks in glass reflectors are usually caused not by unintentionally whacking them with pliers, but by accidental jamming together of the negative and positive carbons of H-I arcs.

Causes of Mirror Cracking

When the two carbons are jammed tightly together, a "trap" is created in which white-hot carbon gas—vaporized carbon—collects under pressure. The volatilized carbon cannot escape until the gas pressure is high enough to blow off the tip of the spindled, or pencilled, negative carbon. When this tiny explosion occurs, a stream of carbon gas is forcibly ejected toward the mirror and condenses upon the comparatively cool glass surface as a large spot of black soot. The mirror does not usually crack at once, but as soon as the reel has been run and the lamp turned off, conditions begin to develop which may result in a serious cracking of the glass.

Anything black, like soot, absorbs heat from the radiant energy, such as light and infrared rays, which falls upon it. A transparent medium, like glass, transmits heat; while a silvered surface, like the shiny surface of a mirror, reflects heat, not retaining much of it.

What happens when a soot-spotted mirror cools? The glass and silver be-

★

Greetings and Best Wishes

PROJECTIONISTS LOCAL NO. 160

CLEVELAND, OHIO

★

come reasonably cool right away, and the glass contracts slightly as it cools. The heat-absorbing soot-spot, however, retains heat, radiating it away very slowly, thus preventing contraction of the glass on which it lies.

Emergency Mirror Service

Now, when one part of a glass mirror contracts, and another part is prevented from contracting—the part under the hot soot—a mechanical strain develops which ordinary glass cannot withstand. Result: a crack develops from center hole to outer edge.

A mirror, when it cracks, makes a noise like two hammers struck sharply together. It does not sound at all like glass breaking. So when the projectionist hears this unmistakable sound com-

ing from the idle projector, he should at once examine the mirror and wipe off the soot. With only one crack in it, the mirror can be used for the remainder of the show. The light will be just as good as ever. *But*—and this is mighty important—the mirror should be replaced at the earliest opportunity, since the development of a *second* crack will cause the mirror to shatter completely.

When replacing the mirror in one machine, it is good practice to install a new mirror in the other machine, too, in order that the performance of the two projectors be exactly equal in quality. Money is saved by using only mirrors made of heat-resistant borosilicate glass, such as Pyrex. The initial cost is slightly greater, but they don't crack so readily.

[TO BE CONTINUED]

How Many?

Was this copy dog-eared when it came to you? How many men read it ahead of you?

You would receive a clean, fresh copy if you had a personal subscription—and you wouldn't have to wait—you would be first to read it.

Use coupon below.

INTERNATIONAL PROJECTIONIST.

19 West 44 St., New York 18, N. Y.

Enter my subscription for 1 year—12 issues—\$2.50
 2 years—24 issues—\$4.00

Foreign and Canada: Add 50c per year.

Name

Address

City State

Medal of Honor



Major General William F. Dean, of Berkeley, California—Medal of Honor. In the hard early days of the Korean War, when it was Red armor against American rifles, General Dean chose to fight in the most seriously threatened parts of the line with his men. At Taejon, just before his position was overrun, he was last seen hurling hand grenades defiantly at tanks.

General William Dean knew in his heart that it's every man's duty to defend America. You know it, too. The General's job was in Korea and he did it superbly well. Your defense job is here at home. And one of the best ways to do that job is to start right now buying your full share of United States Defense* Bonds. For remember, your Defense Bonds help keep America *strong*, just as soldiers like General Dean keep America safe. And only through America's strength can your nation . . . and your family . . . and you . . . have a life of security.

Defense is your job, too. For the sake of all our servicemen, for your own sake, help make this land so powerful that no American again may have to die in war. Buy United States Defense* Bonds now—for *peace!*

Remember that when you're buying bonds for national defense, you're also building a personal reserve of cash savings. Remember, too, that if you don't save *regularly*, you generally don't save at all. Money you take

home usually is money spent. So sign up today in the Payroll Savings Plan where you work, or the Bond-A-Month Plan where you bank. For your country's security, and your own, buy U. S. Defense Bonds now!

****U.S. Savings Bonds are Defense Bonds - Buy them regularly!***



The U. S. Government does not pay for this advertisement. It is donated by this publication in cooperation with the Advertising Council and the Magazine Publishers of America as a public service.



24 TEETH...

that Don't Bite!



24 TOOTH
SPROCKET
found
only in
SIMPLEX X·L

To guarantee projectionists an even, flutterless screen image, SIMPLEX X·L Projectors have been equipped with a revolutionary 24 tooth sprocket!

... 24 teeth—8 more than in ordinary sprockets!

... 24 teeth that draw film more smoothly, more gently along!

... 24 teeth that reduce sprocket r.p.m. by one-third!

... 24 teeth that save sprocket, stud and bearing wear!

... 24 teeth that assure better performance, easier maintenance!

And this 24 tooth sprocket is found *only* in the SIMPLEX X·L! A perfect example of the many exclusives found in this, the world's finest, most dependable motion picture projector!

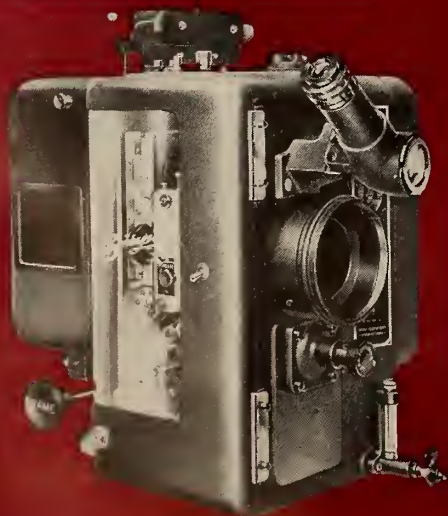

Simplex

T.M. REG. U. S. PAT. OFF.

X·L

PROJECTION and SOUND SYSTEMS

Better Projection Pays



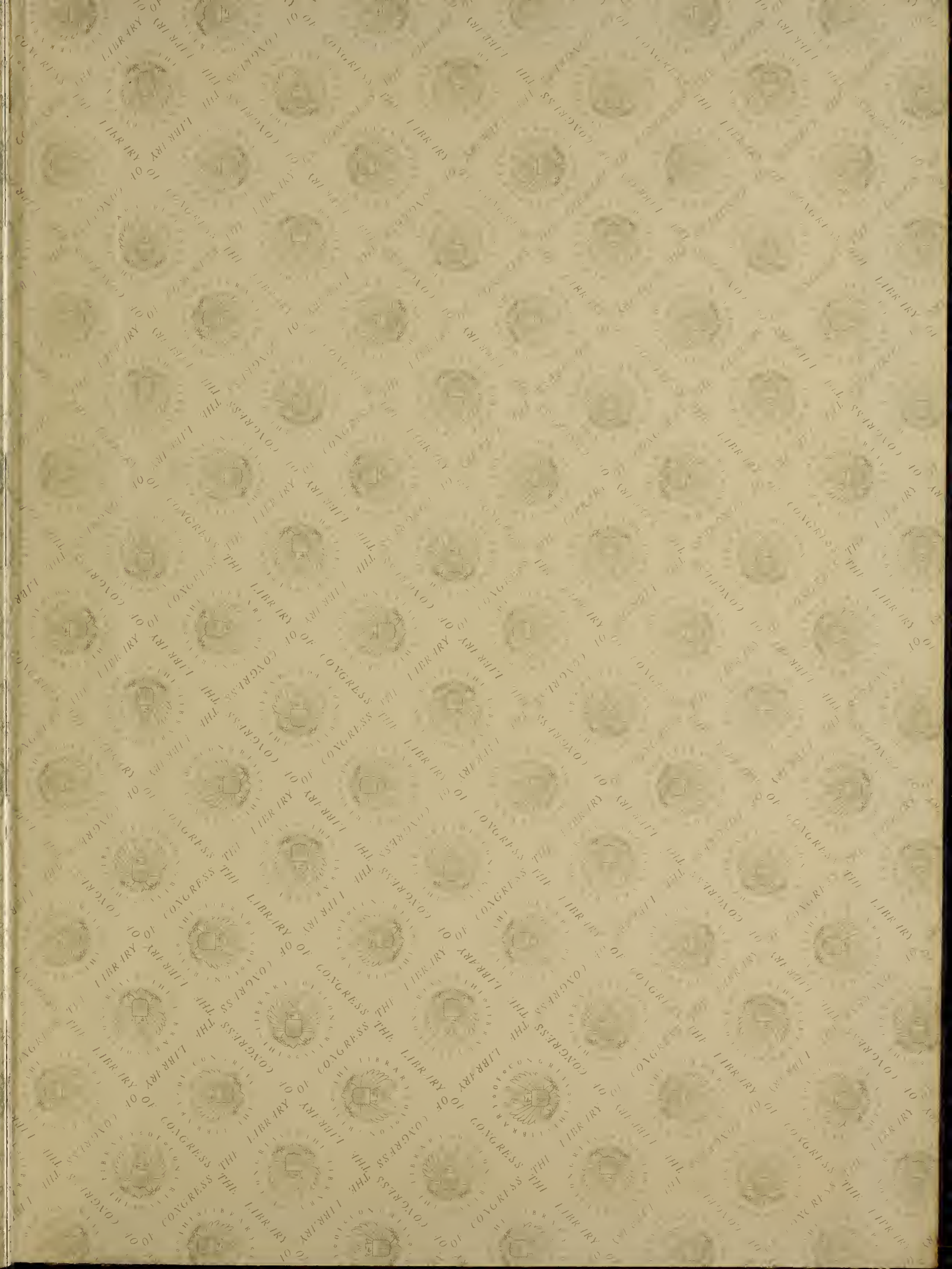

LIBRARY OF CONGRESS



0 013 660 242 1