

T
353
L4

UC-NRLF



\$C 19 545

YE 11097

MECHANICAL
DRAWING
FOR
TRADE SCHOOLS
—
C. C. LEEDS



D. VAN NOSTRAND COMPANY
PUBLISHERS NEW YORK

LIBRARY
OF THE
UNIVERSITY OF CALIFORNIA.

Class

The D. Van Nostrand Company

intend this book to be sold to the Public
at the advertised price, and supply it to
the Trade on terms which will not allow
of reduction.

Carnegie Technical Schools Text Books



MECHANICAL DRAWING

FOR

TRADE SCHOOLS

BY

CHARLES C. LEEDS

Assistant to Head of School for
Apprentices and Journeymen
Carnegie Technical Schools

HIGH-SCHOOL EDITION

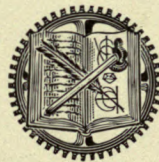

NEW YORK

D. VAN NOSTRAND COMPANY

1908

FT 353
LJ

GENERAL

COPYRIGHT, 1908
BY
D. VAN NOSTRAND COMPANY

THE
VAN NOSTRAND PRESS
NEW YORK



PREFACE.

THE purpose of this book is twofold: To prepare High-school students to pass the examinations required for admission to Technical Schools, and to enable the High-school graduate to earn his living as a tracer or detail draftsman.

The author's conviction that the use of models serves to develop copyists and often tends to stunt or destroy a draftsman's creative faculties, has led him to discard entirely the use of models in teaching Mechanical Drawing, and he feels that it will be obvious, even to the casual observer, that when a student has been given a model of his subject for the drawing lesson, little or no effort will be required from his imagination.

The model stands before his eyes, complete; no effort on his part is necessary. When the student, however, is given a blue-print or drawing of the subject, difficulties arise at every step. In order to understand the meaning of the views shown, he has to study the subject carefully and grasp the meaning of each line. In short, he has to think. To form a MENTAL PICTURE of the piece illustrated is more difficult than mere copying; it is also more beneficial.

That faculty of imagining, that mental picturing so necessary to the good draftsman or designer, can be developed within every student. It is a part of his development, just as an understanding of the meaning (either definite or conventional) of each line of a drawing is a part of his development.

Convinced of this fact, the author has arranged these lessons in a manner which he believes will attract and hold the attention of the student. Each lesson will guide the student by easy steps, illustrate some fundamental point in Mechanical Drawing, and work as a whole towards the development of the creative draftsman.

The results obtained by the author at the Carnegie Technical Schools, through this mode of teaching, justify him in this belief, and prompt him to place within reach of every one interested in the subject this simple treatise, which he hopes will be as fruitful in the hands of others as it has been in his.

CHARLES C. LEEDS.

March 15, 1908.

192820

LESSON No. 1.

PENCILS.—It is very important that the student of Mechanical Drawing should have good tools to work with, and just as important that he should learn to take good care of them that they may be always ready for use. No tool is more used in mechanical drawing than a lead pencil, yet no tool is so greatly abused, mainly because it is not very expensive.

Pencils for drawing are made of various degrees of hardness to suit the purposes for which they are to be used. There are a number of methods of designating the degree of hardness,—one of the commonest being to mark them 2H, 4H, 6H, etc., the harder the pencil, the higher the number preceding the H.

For drawing on the common Manilla papers, 4H is a very satisfactory pencil, though 6H wears better and does not require to be sharpened so often.

To do accurate drawing, it is necessary to keep the pencil well sharpened. The following methods for sharpening are highly desirable.

ROUND POINT.—The first method is known as the “Round Point.” This is produced by first cutting away the wood, as shown in the illustration, Fig. 1, and then sharpening the lead on a file.

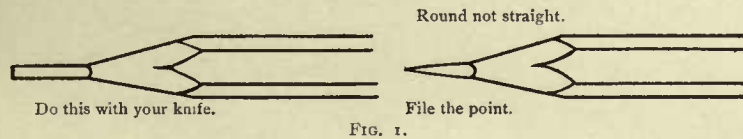

About one inch from the end of the pencil, beginning on one of the six corners, cut away the wood in a clean manner so as to bare about $\frac{3}{8}$ " of the lead; then sharpen it on the file by drawing it towards you. Turn the pencil slowly away from you, taking a fresh hold with each stroke, so as to keep the pencil turning on its axis as it is moved along the file.

FLAT POINT.—The “Flat Point” is very useful when it is desired to draw very fine accurate lines, such as the center lines, construction lines, etc. In sharpening the flat point, enter the knife about one inch from the end of the pencil on one of the flat sides (not corner), and cut away the wood in the manner shown in the illustration, Fig. 2, baring about one-half inch of the lead.

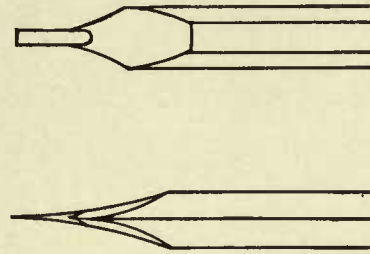

To sharpen the lead, slide it back and forth along the file, forming a long chisel-like point.

The flat side of the lead should parallel the flat side of the pencil when the point is finished.

PAPER.—The drawing paper commonly used in commercial drafting rooms is known as Manilla paper.

There are a great many different grades of this paper manufactured, but the main points necessary to keep in mind when making a selection are: color, erasing qualities, and toughness of fibre.

The standard sizes of drawings adopted by the Carnegie Technical Schools are: A sheets 22"×30", B sheets 15"×22", and C sheets 11"×15".

Drawing paper should be fastened to the board as smoothly as possible; for it is very difficult to make an accurate drawing on paper which does not lie flat on the board.

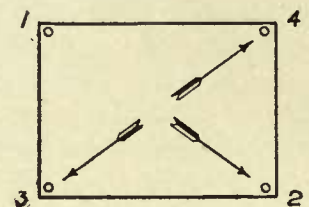

FIG. 3.

LESSON No. 1.—Continued.

The method of mounting paper, shown in the above illustration, Fig. 3, needs very little explanation, and if the student follows the directions with reasonable care, the result will be entirely satisfactory. Place the tacks in the order numbered, stretching the paper in the direction indicated by the arrows.

Push the tacks well down, so that the heads bind the paper closely; this will also enable the T square to slip over them easily without knocking small chips out of the edge of the blade.

DRAWING BOARD. — T SQUARE. — TRIANGLES. — The Drawing Board should be made of a soft wood, well-seasoned white

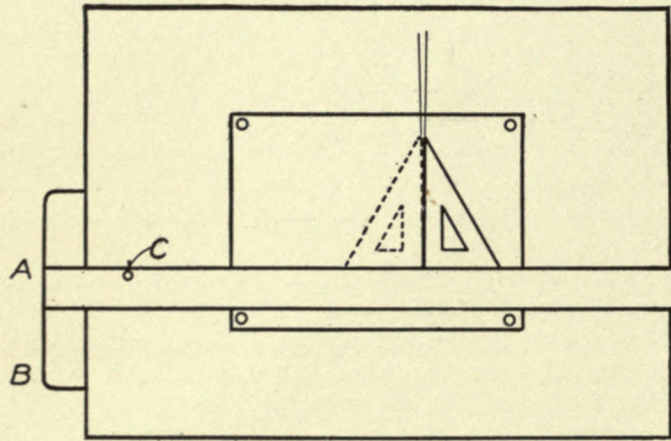

FIG. 4.

pine preferred, so that the thumb tacks may be easily pushed into or drawn from it.

One end of the board must be perfectly straight, as well as smooth, and free from bumps or high spots.

A T Square of well-seasoned pear wood is inexpensive and should give satisfactory results.

The inside edge of the head and the upper edge of the blade should be perfectly straight, and be smoothly and accurately finished.

The Triangles commonly used by draftsmen are the 45° and the $30^\circ-60^\circ$ angles; and it is preferable that they should be made of some transparent material.

The student should realize the necessity of learning to use these tools properly if he desires to do accurate work. The head of the T Square should be kept pressed against the edge of the board when in use; place the hand at A, Fig. 4, rather than at B, and press the blade flat against the board by placing the thumb at C.

The student should work from the left side of the board at all times, and when drawing *vertical lines*, he should use the left side of the triangle as a ruling edge.

The left side of the triangle is the most natural one to use, as the

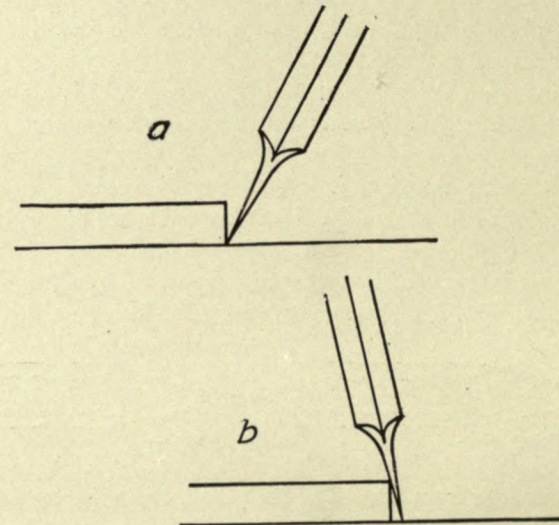

FIG. 5.

arm is held in an easy position when drawing a line away from the square blade. Besides, when tracing with ink, the student would find it extremely awkward and tiresome to use the right side of the triangle.

LESSON No. 1.—Continued.

Hence this general statement: Accurate work is practically impossible when both sides of the triangle are used to rule vertical lines on the same drawing. The reason is that triangles are very often inaccurate.

Fig. 4 shows where the trouble lies and gives the student a way of testing the accuracy of his own triangles.

RULING LINES.—A very common cause of inaccurate work is the careless manner in which the lines of a drawing are ruled; if the student will consider the angle formed by the edge of the T Square and the surface of the paper as a groove, and then, leaning the pencil slightly *away* from the ruling edge, drag the point along this groove, he will have no difficulty in ruling a straight line.

(a) in the illustration, Fig. 5, shows the correct method, and (b) the incorrect one.

WEARING THE PENCIL POINT.—Draftsmen pick up a good many little tricks or habits that are of advantage in their work. One of them is a method of wearing the pencil point in such a way that it will stay sharp a long time.

The Flat Point is shown in illustration (a), Fig. 6, and the method is too evident to need further explanation.

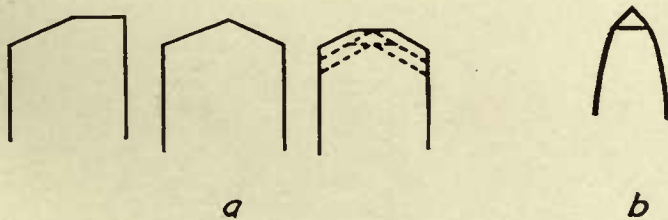

FIG. 6.

When ruling a line with the round point, turn the pencil slowly and deliberately, so that it revolves on its axis as it is dragged along the ruling edge.

This method will result in lines of an even thickness and color, and,

as shown at (b), preserve for a long time the sharp conical point of the pencil.

SCALE.—The draftsman's flat rule (or scale, as it is generally termed), which is graduated in sixteenths on one edge and thirty-seconds on the other, will be found very satisfactory.

When selecting a scale it is advisable to choose one with the graduations cut in a white surface, as the strain on the student's eyes is much less than when using a steel scale or one of plain boxwood.

ACCURACY.—If we stop to analyze the mechanical part of the work of a draftsman, we realize that a great portion of his work consists in placing points on the surface of the paper and connecting them with lines, or in drawing lines through them.

When enough of these points and lines have been placed upon the paper, the drawing of the figure is complete.

To make a mechanical drawing accurately, it is absolutely essential that the points be placed in their proper positions.

In connecting them with lines, or in drawing lines through them, the lines should pass through the *center* of the points.

If the student is unable to do this properly, it naturally follows that he is unable to make an accurate drawing.

LINE THROUGH A POINT.—1st. With the round-point end of the pencil, make twenty small points upon the paper, one above

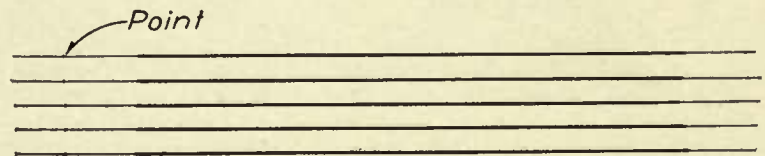

FIG. 7.

another, and about $\frac{1}{8}$ of an inch apart; then, with the flat-point end of the pencil, rule with the T square a fine, clear, straight, horizontal line through each point, as shown in Fig. 7.

These lines may be 6 or 8 inches long. Rule ten of them by adjusting the blade of the T square up to the point, and ten by placing the

LESSON No. 1.—Continued.

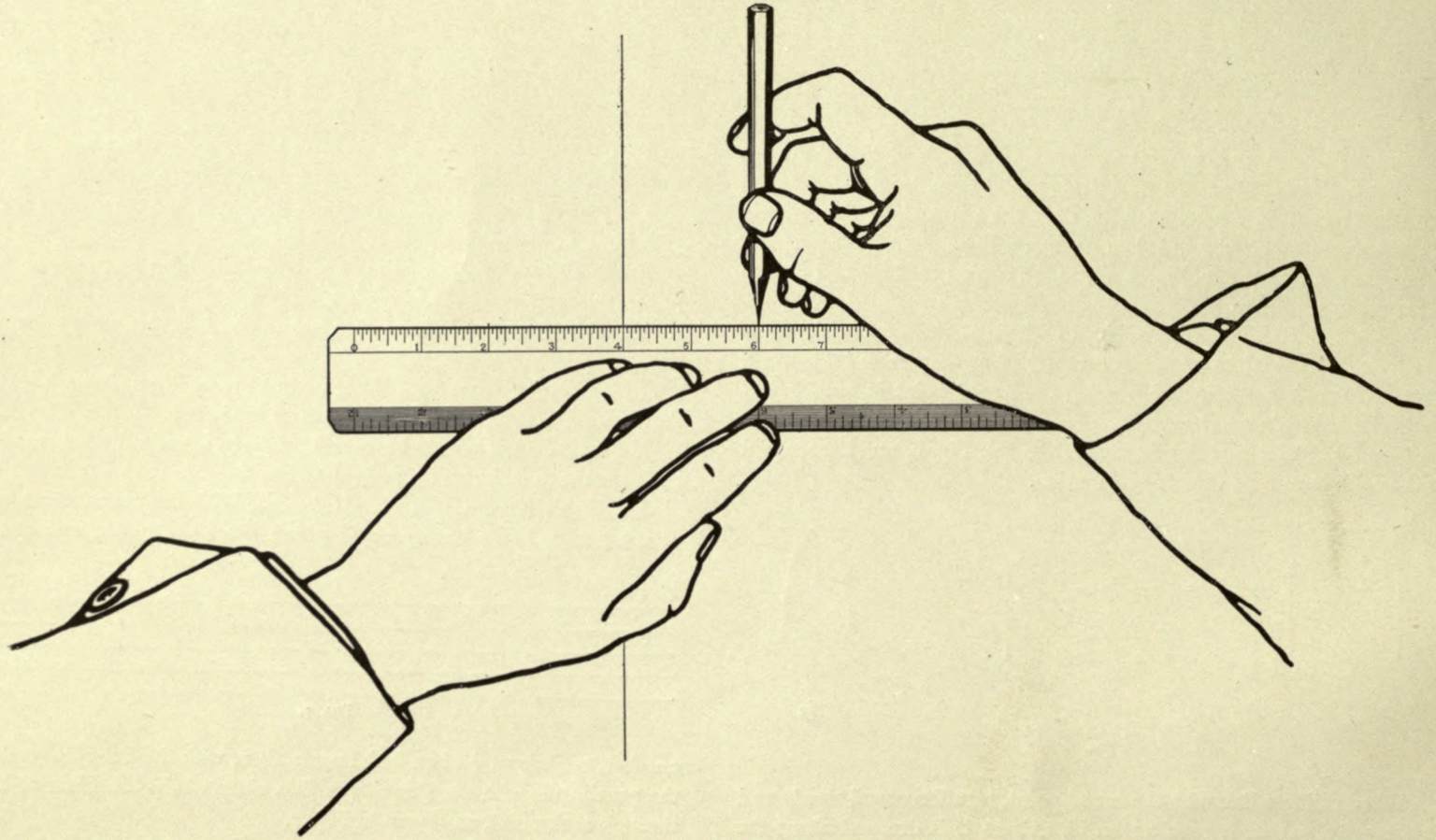

FIG. 8

LESSON No. 1.—Continued.

pencil point in position and bringing the ruling edge gently up to it. These fine lines are called "construction lines," from the fact that when used in practice, the drawing is built upon them. The student should endeavor to "split" the point each time.

Now, with the round-point end of the pencil, "line in" about 3 inches of each line to the right of the point.

By the term "line in," we mean to make that portion of the line heavier, so that the result will be a strong, clear line, such as should be shown on a finished drawing. When lining in, the student should be very careful to cover the construction line perfectly.

Lining in a little above or a little below the construction line results in inaccurate work.

2d. Repeat above, ruling vertical lines and 45° lines, using the T square and the 45° triangle.

LAYING OFF DIMENSIONS.—3d. Draw fifteen straight lines just 4 inches long; these lines to be horizontal, vertical, and 45° .

In each case use the method described above; first a fine construction line more than 4 inches long, then, using the scale in the manner shown in the illustration, Fig. 8, lay off two points which are exactly 4 inches apart, and "line in" that part of the construction line between points.

THREE-INCH SQUARE.—4th. Using the T square and the 45° triangle, construct a 3-inch square. Rule the lines in the order shown by numbers in the illustration, Fig. 9.

Lines 1, 2, and 3 should be construction lines at first. Finish the square by lining in these sides.

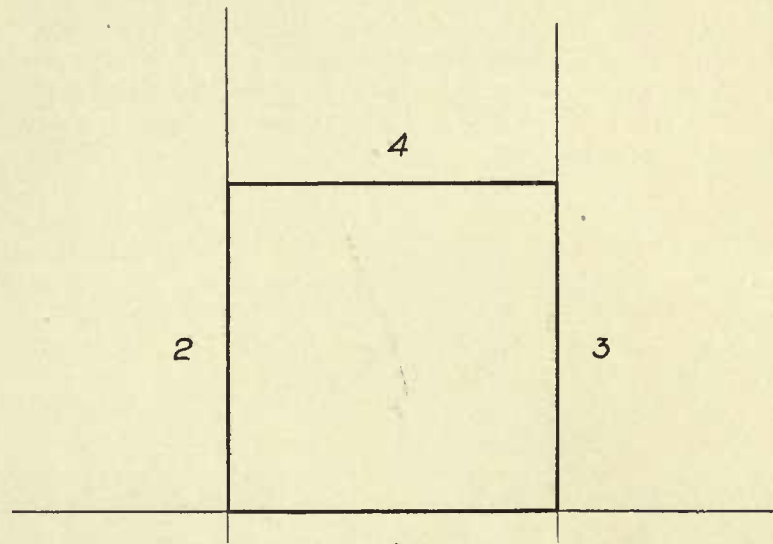

FIG. 9.

When the square is finished, the length of each side should be exactly 3 inches.

LESSON No. 2.

ACCURACY.—The student should at all times endeavor to make accurate drawings, and he will find that it is only by constant effort on his part that this can be accomplished.

This lesson is a test in accuracy, and it is necessary that the student should exercise great care in laying out these figures.

COMPASS POINTS.—Get the pencil compasses ready for use.

In preparing the large compass, remove the pencil leg and, with the file, produce a “flat point” very similar to the “flat point” of the pencil. Trim off the sides so as to get a narrow “flat point” as shown in the illustration, Fig. 10.

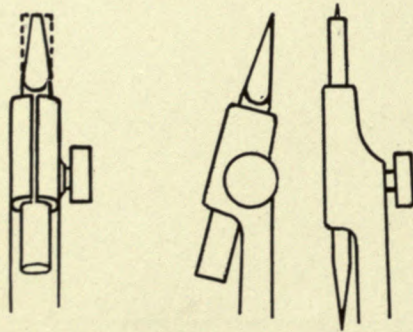

FIG. 10.

The pencil point of the spring-bow compass should be sharpened in the same manner, except that the finished point should be slightly narrower than the one in the large compass.

SETTING LEAD.—When adjusting the legs of the large compass, see that the pencil point is slightly shorter than the needle point; about to the shoulder of the latter.

The flat side of the lead should be set at right angles with the needle point. If this requirement is not met with, the compass tends

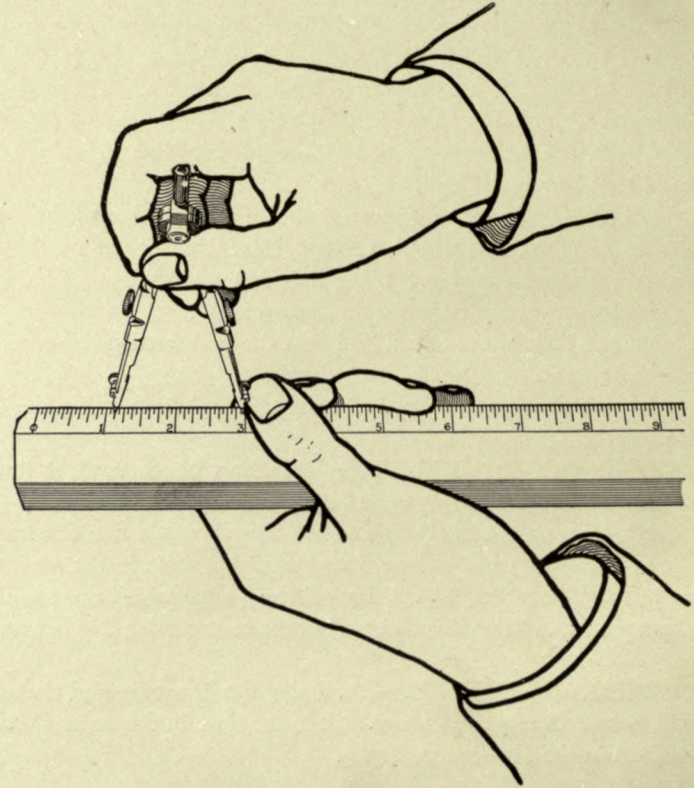

FIG. 11.

to open when it is turned in one direction, and to close when turned in the other.

LESSON No. 2.—Continued.

After the compass legs are properly adjusted for length, test the setting of the lead by drawing a circle clockwise, then, without removing the needle point from the paper, swing one counter-clockwise. The result should be one clear sharp circle; if this is not the case, the lead should be adjusted to correct the error.

SETTING COMPASS.—With the large compass, take a radius of $1\frac{1}{2}$ inches and describe a 3-inch circle.

Now, test the circle for a diameter of 3 inches, using the scale. Reset the compass and repeat above test several times, so as to gain confidence in setting the compass. When setting the latter, handle it, and also the scale, as shown in the illustration, Fig. 11.

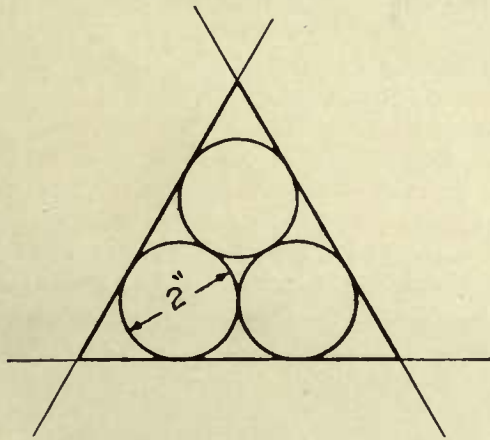

FIG. 12.

TANGENT CIRCLES.—TRIANGLE.—Describe three 2-inch circles tangent to one another.

Surround the circles by a tangent triangle. “Line in” the triangle and test it for accuracy, using the dividers; the sides should be of equal length.

Repeat this three times.

Great care should be exercised by the student in laying out this figure, which presents so many chances for error that it is quite difficult to draw correctly.

SQUARE.—Construct a 3-inch square, using the T square and triangle. The square to have rounded corners of $\frac{1}{2}$ -inch radius, made with the bow-pencil compass.

The finished square should be “lined in” so that there are no visible joints.

Where rounded corners join straight lines on a mechanical drawing, the joint should be so nearly perfect as to be unnoticeable. Care in these little details adds greatly to the attractiveness of a drawing, and they should never be overlooked.

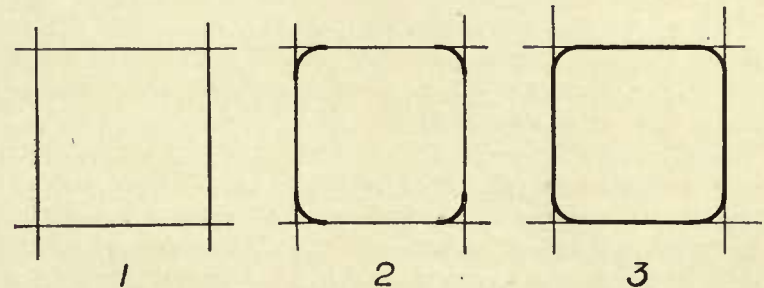

FIG. 13.

The student should observe that in the illustration, Fig. 13, the square is first laid out in faint construction lines, then the corners are rounded, and, finally, the sides are “lined in.”

The rounded corner lines should be made as heavy as it is desired to make the rest of the outline, so that in “lining in” the sides, the lines may be made of the same weight.



LESSON No. 3.

FLANGED PIN.—Make a full-size three-view outline drawing of the flanged pin shown in the illustration, Drawing C-1000.

View (*a*) shows the shank end of the pin as seen from the position of (*a*). View (*b*) is a side view of the flanged pin, and (*c*) is a view of the round end as seen from the position of view (*c*). The student should study the illustration carefully, and try to understand clearly the meaning of each line. The position of each view is given in relation to the edge of the sheet.

THE DRAWING.—To make the drawing, first lay out the center lines, as they fix the positions of the views. Second, draw view (*a*), throwing in the circles, then, with the T square and 45° triangle, construct the square representing the shank end. Third, draw view (*b*), setting the compasses with care each time, so that the circles are drawn exactly

to scale. Fourth, lay off the lengthwise dimensions of the pin, then draw vertical construction lines through these points (lines of any length); now place the T square so as to project the horizontal lines of the pin from the end views. With a $\frac{3}{4}$ -inch radius, throw in the curved lines representing the chamfer on the shank end. Observe how the radius center line is projected from the end view.

FINISHED DRAWING.—In finishing the drawing, “line in” the whole outline with care to give it a neat appearance, and to make it clear and distinct, so that all the lines can be easily seen through the tracing cloth. Do *not* put in any of the dimensions. The finished drawing should show only the outlines of the pin with the vertical and horizontal center lines.

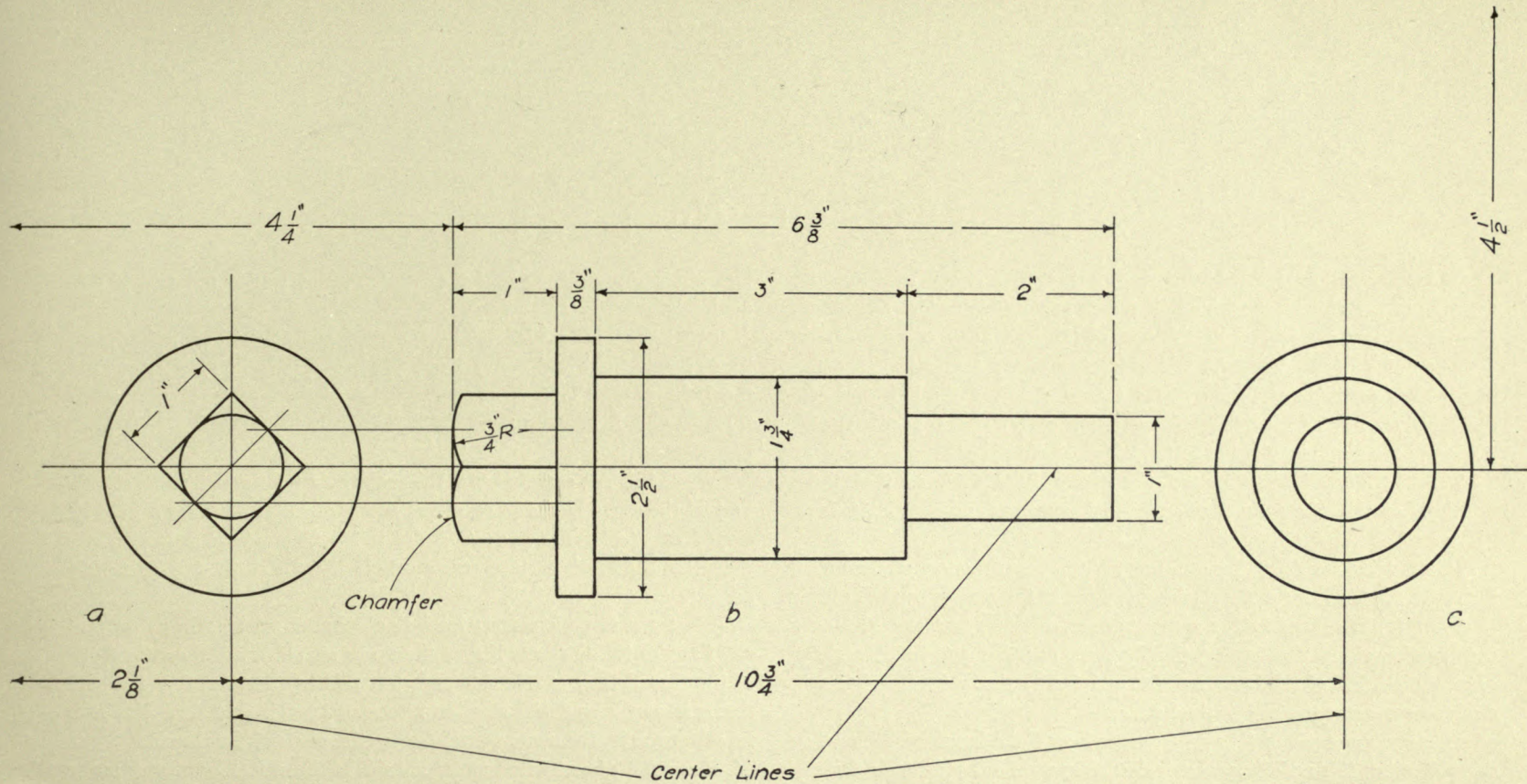

THE CARNEGIE TECHNICAL SCHOOLS
PITTSBURGH, PA.

FLANGED PIN

CLASS Industrial TRADE Machinist

SCHOOL OF APPRENTICES AND JOURNEYMEN
MECHANICAL DRAWING

NAME John W. Roberts DATE Feb. 16-06.

SCALE Full Size

DWG. No. C-1000



LESSON No. 4.

MACHINE BOLT.—Make a full-size three-view mechanical drawing of the $1\frac{1}{2}$ -inch machine bolt shown in the illustration, Drawing C-1001. View (*a*) represents the end of the bolt head as seen from the position of (*a*). View (*b*) is a side view of the bolt and hexagon nut. View (*c*) is an end view of the threaded end of the bolt and of the hexagon nut as seen from the position of (*c*). The positions of the views are given in relation to the edges of the paper.

THE DRAWING.—Lay off the center lines first, so that the positions of the views are fixed at the beginning; do not let them “happen” as regards location.

In drawing view (*a*), lay out the $2\frac{1}{4}$ -inch construction circle, and then with the T square and 45° triangle, draw in the outline of the head.

View (*c*) is drawn in the same manner, that is, first the $2\frac{3}{8}$ -inch construction circle, then, using the T square and the 30° – 60° triangle draw the outline of the hexagon nut, and finally throw in the $1\frac{1}{2}$ -inch circle to represent the end of the bolt.

Having drawn views (*a*) and (*c*), now lay off the lengthwise dimensions of view (*b*), and draw vertical construction lines through these points (lines any length). With the T square, project the horizontal lines of the bolt from the end views, these lines to be light construction lines, until their true length is known. Now swing in the various radii, make them as heavy as the final outline is to be, and line in the bolt

and nut completely, so that the whole outline stands out clearly and distinctly.

SCREW THREADS.—The threaded end of the bolt is indicated by alternate light and heavy lines, the heavy lines being shorter than the light ones. This is a conventional method of indicating screw threads, and it has the merit of being easily understood and is inexpensive.

While it is not essential that the space between the light lines should be just the same as the pitch of the thread, or that the lines should be sloped at exactly the correct angle, it is of considerable importance that the threaded surface as a whole should look approximately correct.

When the slope is correct for a single-thread screw, a line drawn at right angles to the center line of the screw should touch the end of one of the thread lines at one side and pass midway between that line and the next at the opposite side, as indicated by the light dash line *d-e*. In other words, the slope equals half of the pitch of the thread.

Place the dimensions just as shown in the illustration, and make the figures carefully, so that there can be no doubt as to their meaning. The dimensions which refer to the position of the different views should be left off, as they were intended to aid the student in locating the views, and have no other value.

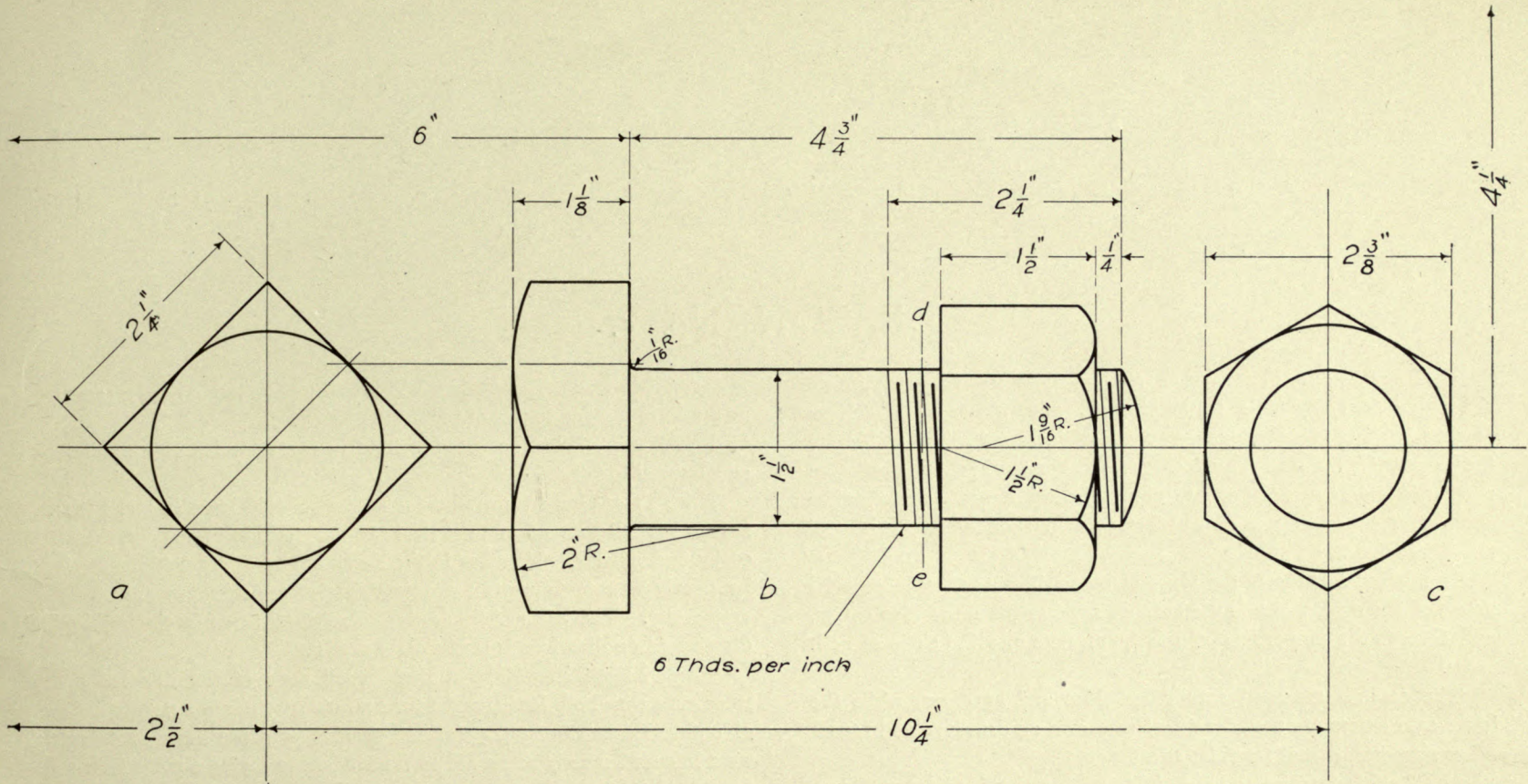

THE CARNEGIE TECHNICAL SCHOOLS
 PITTSBURGH, PA.
 SCHOOL OF APPRENTICES AND JOURNEYMEN
 MECHANICAL DRAWING

MACHINE BOLT

CLASS Industrial TRADE Machinist

NAME John W. Roberts DATE Feb. 20_06.

SCALE Full Size

DWG. No. C-1001



LESSON No. 5.

LETTERING.—The average student does not fully appreciate the value of being able to letter well, and while he is seldom pleased with his lettering, he usually does not like to devote the necessary time to practice. A great many young draftsmen reach the point where they are able to make a neat, workmanlike drawing, the appearance of which they will spoil when they letter, and dimension it.

In making a study of the types of letters illustrated, take especial notice of the oval, which is the basis of most of the lower-case letters, and observe the proportions of this type; note also the slope of both types.

The capitals are used mainly for titles and headings, while the lower-case letters are used for all notes shown on drawings and for all other purposes, except for titles and headings.

As an aid in learning to letter, it is well to use guide lines as shown

in the illustration. The student will find the slope guide lines a great help also in making letters of uniform appearance.

FIGURES.—What has been written in regard to lettering applies equally well to figures.

It is of great importance that the student should learn to make his figures so well that no one should have any trouble in reading them easily and quickly. Mistakes in the shops are very frequently caused by poorly written figures on drawings, and these mistakes are often very costly. The value of using great care at all times in placing the dimensions on drawings is thus clearly shown.

THE LESSON.—Make a neat pencil copy of the illustration, using care with both letters and figures; note carefully the proportions of both. Leave off figures showing spacing of guide lines, as these were intended merely as an aid to the student in laying out his lesson sheet.

The Slope of Letters and Figures

1 2 3
 1
 2
 3
 4
 5
 6
 7
 8

ABCDEF GHIJKL MNOPQRST UVWXYZ

Standard Capitals

ABCDEF GHIJKL MNOPQRST UVWXYZ
 ABCDEF GHIJKL MNOPQRST UVWXYZ
 ABCDEF GHIJKL MNOPQRST UVWXYZ
 ABCDEF GHIJKL MNOPQRST UVWXYZ

Example
 STANDARD TITLES

The Oval

OOOOOOOOOO
 OOOOOOOOOO
 OOOOOOOOOO

Proportions

1 2 3 4 5 6 7 8 9 0
 1 2 3 4 5 6 7 8 9 0
 1 2 3 4 5 6 7 8 9 0
 1 2 3 4 5 6 7 8 9 0

abcdefghijklmnopqr
 abcdefghjmnopqr
 abcdefghijklmnopqrstuvwxyz
 abcdefghijklmnopqrstuvwxyz

← Arrow Heads →

$1\frac{1}{2}''$ $5\frac{1}{8}''$ $6\frac{3}{4}''$ $9\frac{5}{8}''$ $2\frac{7}{64}''$

Standard Lower Case

abcdefghijklmnopqr
 abcdefghijklmnopqrstuvwxyz

Example For all notes on drawings

Oct. 25, 1906 Fig. 7 Dwg. 15763



LESSON No. 6.

SKETCHING.—Whatever course in mechanical drawing the student may pursue, he will sooner or later desire to know something about sketching, or, at least, he will feel the need of it.

A knowledge of sketching is exceedingly useful to men of most of the trades, and the lessons on this subject have been planned with the belief that they may assist the students to use their pencils more freely and easily in making simple mechanical drawings free-hand.

METHOD.—The method that we shall follow, we shall call the "Short-stroke Method," from the fact that as we draw a line in any direction, it is not made by a single stroke of the pencil, but by a series of short strokes. There should be the smallest possible opening between the ends of these short lines, and it would be better still if the ends were to just touch without overlapping.

The object of using these short strokes is to enable the student to correct an error in direction at any point along the line. The result is that the general direction of the line is straight, and though there may be slight errors along the line, they in nowise cause any doubt as to its meaning.

PENCILS.—For sketching, a pencil equalling an H or HB in hardness will give very satisfactory results, though a 2H Koh-i-noor will last much better. The latter, however, is just a little too hard except when used on Manilla paper.

Learn to hold the pencil easily and naturally between the first and second fingers and the thumb, in a manner very similar to that used in writing.

Do not turn the paper to suit the direction in which a line is to be drawn, but fasten it down to the drawing board and try to develop that freedom of movement of fingers, wrist, and arm which will enable one to draw a line in any direction with equal ease.

In drawing straight lines as indicated on the illustration, the student will soon discover that they are made in certain directions by a movement of the wrist mainly. In other directions it is mostly a movement of the fingers which gives the best results.

It is quite difficult to make neat circles free-hand, but by putting into practice the following suggestions, the student should obtain satisfactory results.

The student should sit upright while drawing, so that he may the better get a clear view of his work as a whole. By having the head well up over the work, the eyes can direct the movements of the pencil better, and they are in a better position to see if the desired shape is growing under the pencil, than if held close to the work. Start at a point on the left side, as indicated by the arrows, and with short strokes form the upper half of the circle. Then, starting at the same point, form the lower half in the same manner.

THE LESSON.—Fasten the drawing paper smoothly to the board and divide it into sections, as shown in the illustration.

The straight lines should be drawn about $\frac{1}{4}$ inch apart and in the directions indicated by the arrows.

Draw the circles to the sizes shown, without using a rule; try to see how nearly correct you can make them by the eye.

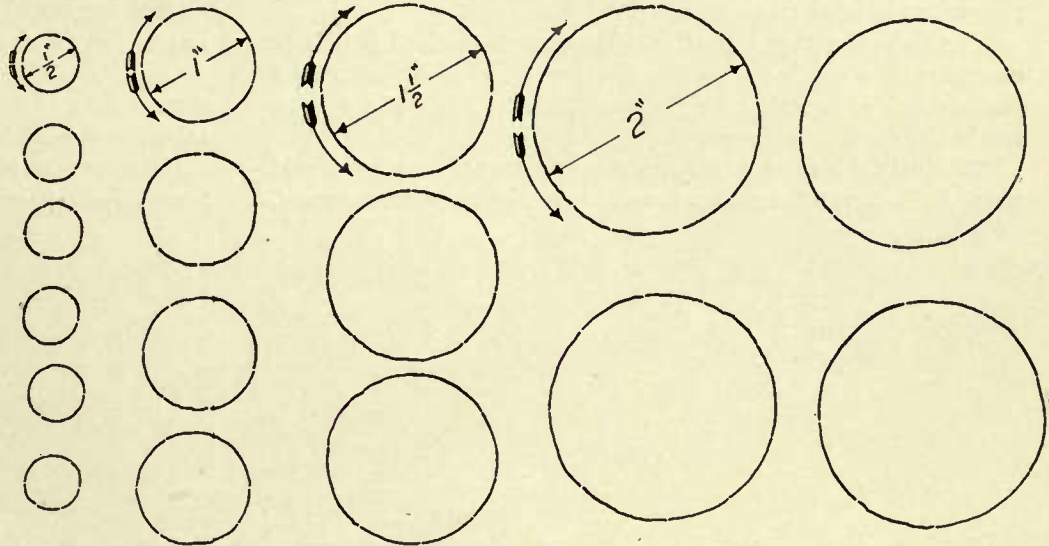
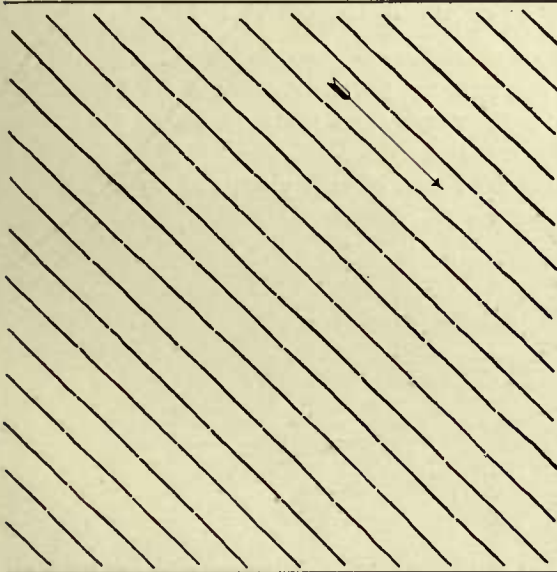
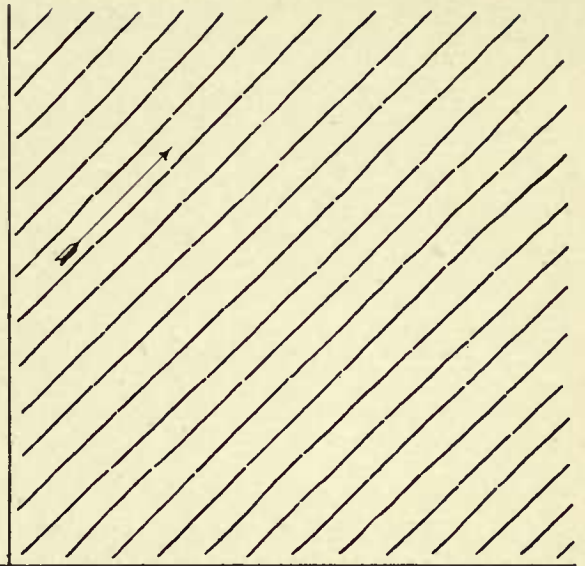
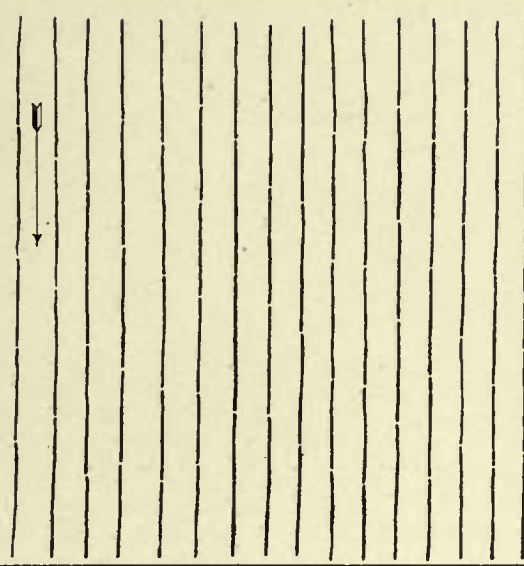
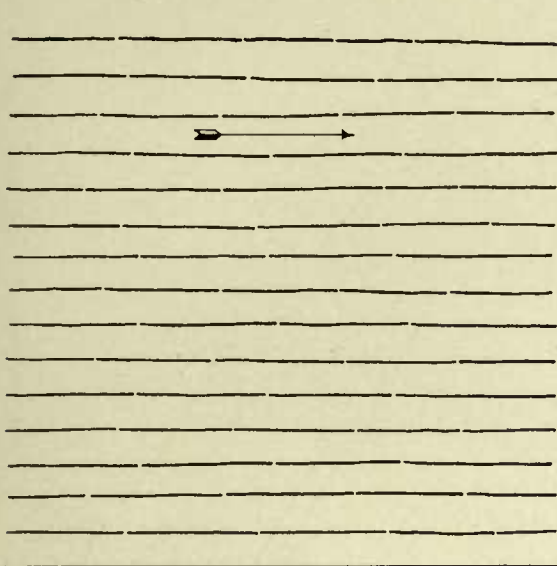

CLASS *Industrial* TRADE *Machinist*
NAME *John W. Roberts* DATE *Mar. 20-06.*

THE CARNEGIE TECHNICAL SCHOOLS
PITTSBURGH, PA.
SCHOOL OF APPRENTICES AND JOURNEYMEN
MECHANICAL DRAWING

SKETCHING

SCALE *Full Size*

DWG. No. *C.1003*



LESSON No. 7.

PROPORTIONS.—It is a very valuable acquirement, when sketching, to be able to make the details of a drawing of the proper proportions in relation to each other.

The scale of a sketch is of little importance, provided it is large enough to show clearly the piece or pieces we desire to illustrate. But that which is of importance is that each piece, or detail of the piece, should be drawn to the same scale.

To obtain this result it is quite necessary that the student should train his faculty of observation so as to have a sense of measurement,

and so that, without the aid of a rule, he may be able to draw a sketch approximately to a given size.

The student will be helped to develop this faculty if, in sketching, he practises drawing to a certain scale or to given dimensions.

LESSON.—Make a neat free-hand full-size drawing of the figures shown in the illustration. Draw each figure to the dimensions given, as nearly as possible, without using a rule.

Observe that two views are shown of each piece, and try to see the relation between the views.

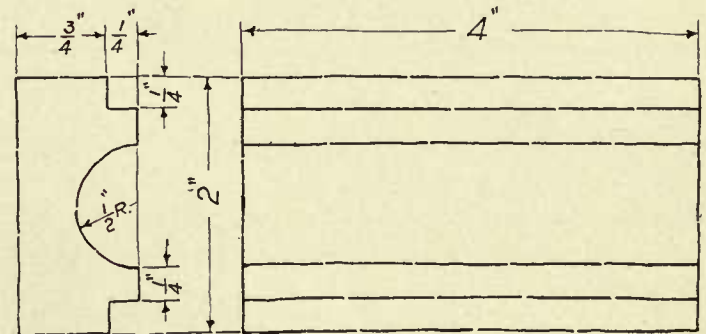
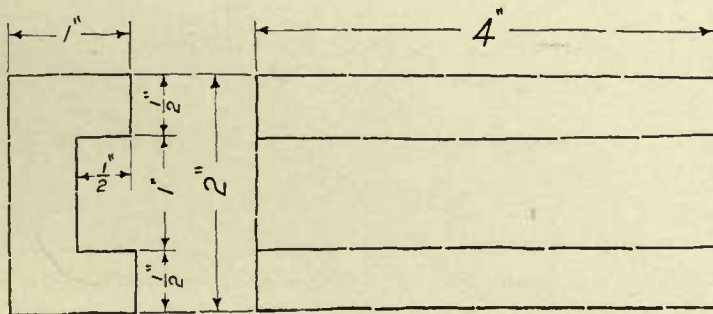
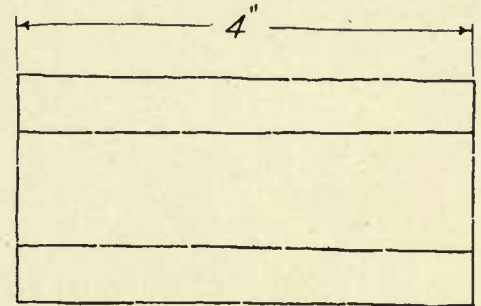
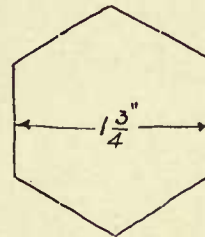
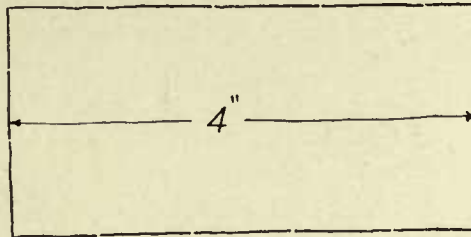
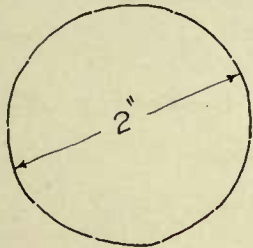
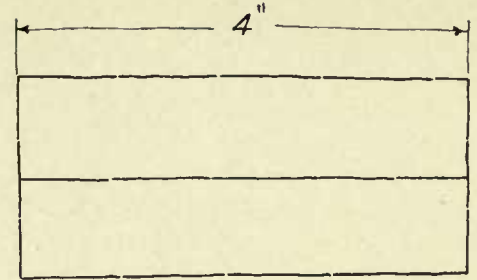
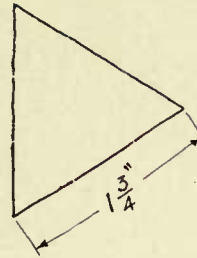
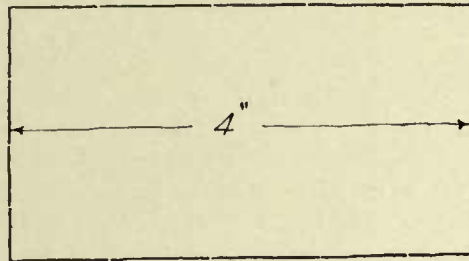
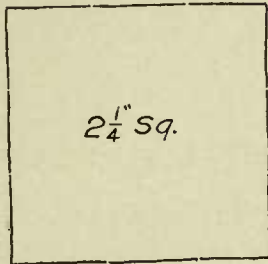

THE CARNEGIE TECHNICAL SCHOOLS
PITTSBURGH, PA.

SKETCHING

CLASS Industrial TRADE Machinist

SCHOOL OF APPRENTICES AND JOURNEYMEN
MECHANICAL DRAWING

NAME John W. Roberts DATE Mar. 20. 06.

SCALE Full Size

DWG. No. C. 1004

LESSON No. 8.

METHOD OF HOLDING PEN.—In learning to trace, one of the first problems which confronts the student is how to hold the instruments.

In general, the ruling pen and the pen point of the compass should be held in such a manner as to bring the points of both jaws on the paper at the same time, as shown at (b) of the illustration, Fig. 14.

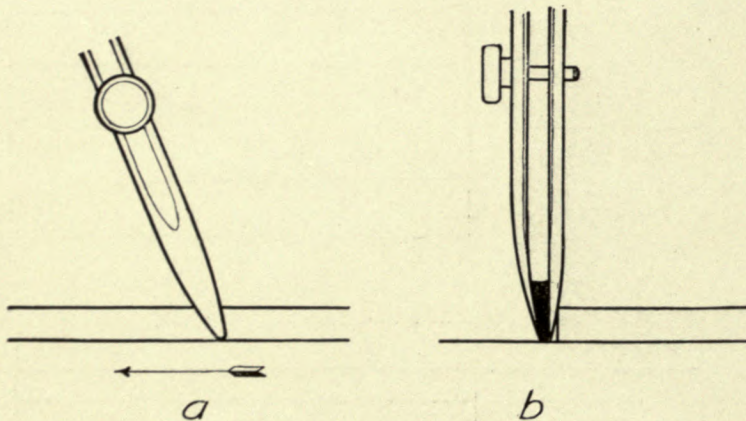

FIG. 14.

Do not lean the pen either toward the ruling edge or away from it, but hold it in a vertical plane, thus obtaining clean even lines free from a ragged edge.

While the pen should not be leaned toward or away from the ruling edge, it will be found that the ink will flow more freely if the pen is leaned slightly *in the direction in which the line is being ruled*, as shown at (a).

When using the pen compass for large circles, the legs may be bent at the joints, so as to meet these conditions.

TRACING CLOTH.—The student will find one side of the tracing cloth with a glazed or calendered surface, while the other side has a dull finish. If the glossy side is used, it will be necessary to dust the surface with powdered chalk or talcum powder, as the ink will not flow freely otherwise. In a great many drafting rooms the dull side of the cloth is used from preference, as it takes ink very well without powder of any kind, though the powder makes the ink flow more freely.

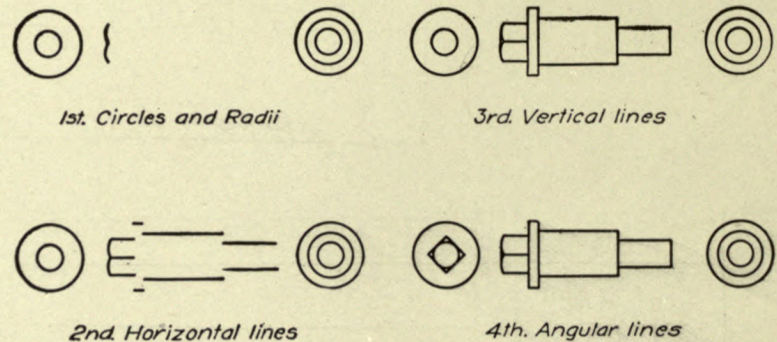

FIG. 15.

CARE OF PENS.—A common mistake of most beginners is to fill the pen with too much ink, with the result that, before they realize it, there is a big blot on their work. This is not necessarily caused by the pen being filled too full, but it is frequently the cause. It is better to fill the pen oftener and to use less ink at one time.

Another very good habit to acquire is to wipe out the pen each

LESSON No. 8.—Continued.

time fresh ink is to be put in, as the ink flows more freely from a clean pen than from a dirty one.

TRACING FLANGED PIN.—Make a tracing of the pencil drawing of the flanged pin.

When beginning a tracing, tack the cloth down carefully over the pencil drawing, then set the compass pen to the desired width of line by testing on the edge of the sheet, and, after it is properly adjusted,

throw in all the circles and radii. Then, beginning at the top, rule in the horizontal outlines; next, beginning at the left side, rule in the vertical outlines and finally the angular lines.

In ruling horizontal lines, use the T square as a ruling edge. For vertical lines, use the left side of the triangle, which should be held against the T-square blade.

Do not use the scale as a ruling edge.



LESSON No. 9.

TRACING MACHINE BOLT.—As mentioned in Lesson No. 8, begin by adjusting the compass pen to the width of line desired for an outline. In deciding on the width of line, the student should bear in

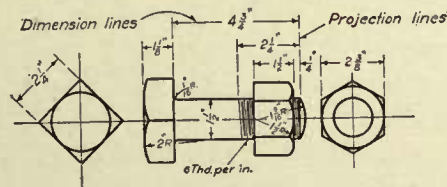
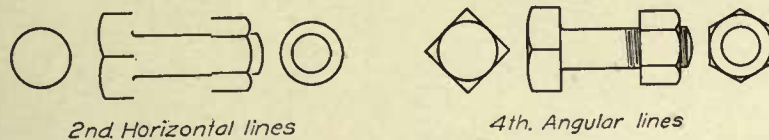
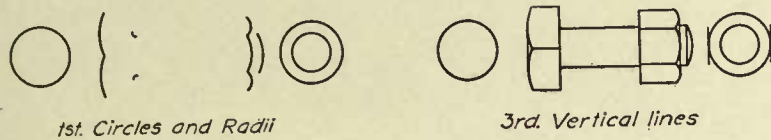

5th. Projection and Dimension lines—

Dimensions—Notes

FIG. 16.

mind that to get blue-prints with clear white lines, it is necessary that the lines of the tracing be fairly heavy; not the fine, “pretty” lines that beginners are so prone to use.

The illustration shows the various steps in making a tracing: First, throw in all the circles and radii; then, beginning at the top, rule in all the horizontal outlines; next, starting at the left side, rule in all the vertical outlines; and, finally, rule in the angular outlines.

Now, adjusting the pen to a much finer line, rule in the projection lines; these lines for drawings of small figures should be composed of dashes $\frac{1}{4}$ to $\frac{3}{8}$ inch long, and for large figures $\frac{1}{2}$ to $\frac{3}{4}$ inch long. Do not let the projection lines touch the figure, but leave a slight opening between the end of the line and the figure.

Next, rule in the dimension lines; these lines for drawings of small figures should be solid except for the opening left for the dimension, but on drawings of large figures they may be broken lines of long dashes,—the length to suit the size of the drawing.

Now, place the arrow heads on the dimension lines and put in the dimensions, using care to make the figures clearly.

FINISHED DRAWING.—In the finished drawing there should be a marked contrast between the weight of the outlines of the figure, and of the center, projection, and dimension lines; the latter should be decidedly lighter than the outlines. When these various lines are drawn to the proper proportions and are well arranged, the figure seems to stand out by itself and is much more easily understood.

When the drawing is completed, print the title on neatly and carefully, as the looks of a good drawing will be spoiled if the printing is done in a careless, slipshod manner.

Use a Gillott's No. 303 pen point for lettering and dimensioning the drawing.



LESSON No. 10.

HIDDEN SURFACES.—Until the present time we have been using lines which could be seen on the surface, or which represented the surface of the figures that we have used as subjects for our drawing lessons.

In mechanical drawing it is constantly necessary to show by some means, surfaces or details of parts that are hidden from view behind the surface shown by solid lines.

Unless these surfaces could be indicated by some simple method, it would often be necessary to make additional drawings or, at least, additional views to show clearly the shape of the figure illustrated.

The method commonly used to indicate these hidden surfaces is to draw them in, in the proper position, but to use dotted lines for this purpose. These dotted lines, or "hidden lines," as they are generally called, have a distinctly different appearance from the solid outlines of

the rest of the drawing, and their meaning should be readily understood.

THE LESSON.—These hidden lines are the essential feature in the present lesson. As they are constantly used in mechanical drawing, we wish to call the student's attention to them.

Make a neat free-hand sketch of the clamp shown on Drawing C-1005.

Finish your sketch neatly; copy carefully all dimensions, and be sure to place your name, the drawing number, and the title of the piece upon it.

From your sketch make a full-size pencil drawing of the clamp; finish it completely with all dimensions, the title, etc.

Use the "Short-stroke Method" in making your sketch.

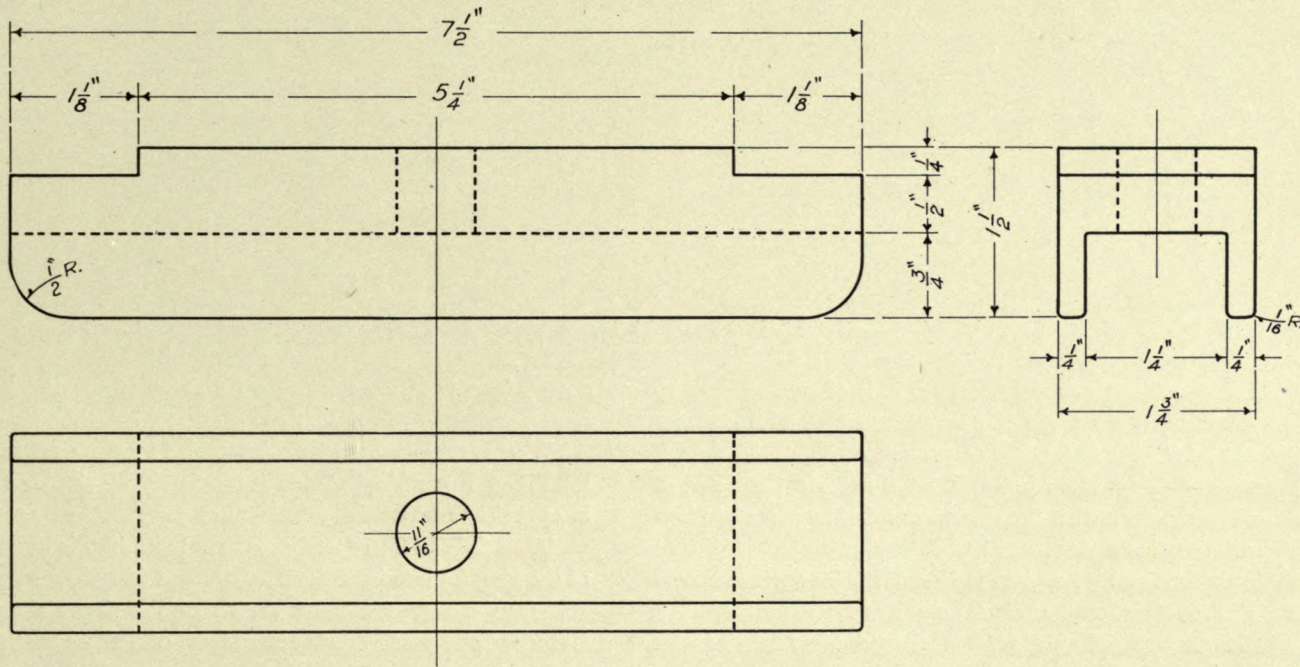

THE CARNEGIE TECHNICAL SCHOOLS

PITTSBURGH, PA.

SCHOOL OF APPRENTICES AND JOURNEYMEN

MECHANICAL DRAWING

CLAMP

CLASS Industrial TRADE Machinist

NAME John W. Roberts DATE Oct. 6.06.

SCALE Full Size

DWG. No. C_1005



LESSON No. 11.

SECTIONING.—When making drawings it is often necessary to show at least one view of the piece or pieces illustrated, with part cut away, or “in section,” as it is generally termed.

The advantage of this method is that it helps to show the shape of the piece more clearly, and often the dimensions can be placed to better advantage on a sectional view.

As an aid in indicating that a piece is in section, the surface is covered with lines called “section lines.” These lines are drawn with the aid of a 45° triangle as a ruling edge, the triangle being held against the T-square blade and moved for each line.

In this course of lessons we will use the section lines shown on Drawing C-1006 for *all metals*, the only variation being that the lines

should be spaced close together for small pieces and farther apart for large ones.

Where two or more pieces assembled together are shown in section, the different parts are shown more clearly by sloping the section lines in opposite directions where the parts join.

THE LESSON.—The important point in this lesson is the method of showing a piece in section.

Make a neat free-hand sketch of the sleeve shown on Drawing C-1006; copy carefully all dimensions, and all necessary data.

From your sketch make a full-size pencil drawing of the sleeve. Try hard for accuracy.

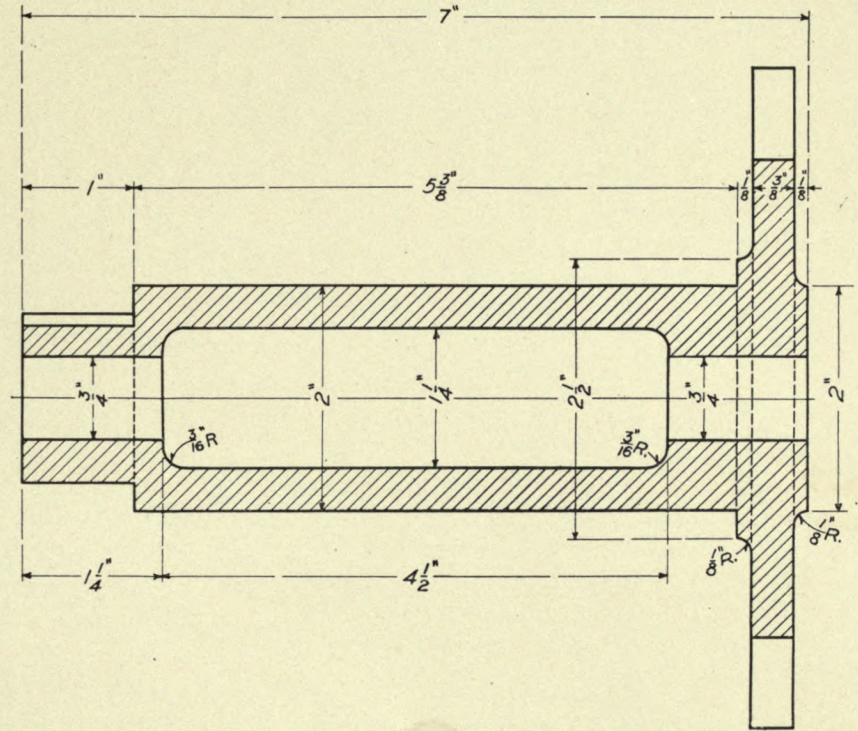
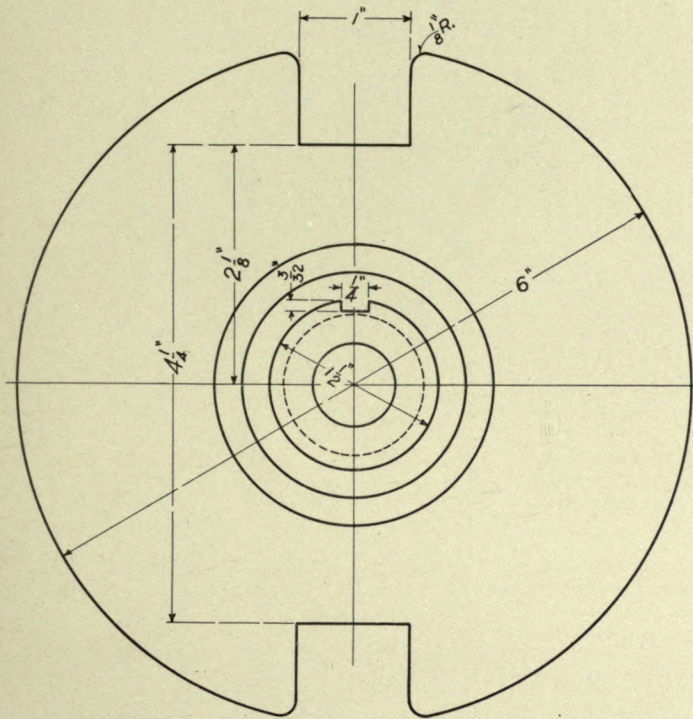

THE CARNEGIE TECHNICAL SCHOOLS
PITTSBURGH, PA.

SLEEVE

CLASS Industrial TRADE Machinist

SCHOOL OF APPRENTICES AND JOURNEYMEN
MECHANICAL DRAWING

NAME John W. Roberts DATE Oct. 24-06.

SCALE Full Size

DWG. No. C-1006

LESSON No. 12.

PROJECTION.—Mechanical drawings to be clearly understood and easily read should be made after certain fixed rules as to the arrangement of views in relation to each other.

There are usually several correct arrangements for the different views of a body, but in each of them the same relationship between the

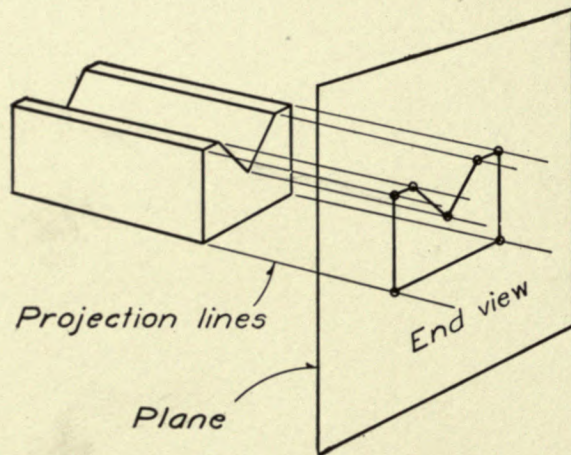

FIG. 17.

views is maintained. To fully grasp the meaning of this, a knowledge of projection is necessary.

Every student of Mechanical Drawing should make a study of the subject of projection, as a thorough knowledge of this subject is necessary in order to read drawings intelligently, and it is absolutely essential for one who wishes to become a good draftsman.

The definition of the word projection (as applied to Mechanical Drawing), given in the Universal Dictionary of Mechanical Drawing

by Prof. Geo. H. Follows, is: "To throw forward in parallel rays or straight lines." "Projection means either the act or the result of projecting parallel rays from the surface of a body, and of cutting these rays with a plane, so as to obtain on the plane a shape, corresponding

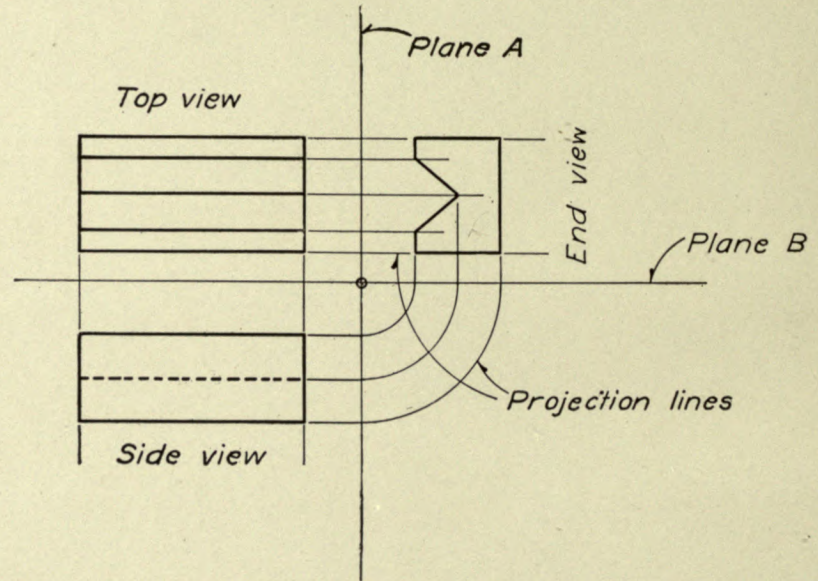

FIG. 18.

point for point with that of the body. In Mechanical Drawing these rays are called projection lines."

Fig. 17 is an illustration of a V block shown in perspective, the end view of the block being projected upon the plane. Projection lines are thrown out from the points or corners of the body, and the

LESSON No. 12.—Continued.

main points where the plane intersects these lines are those which are used in developing the outline of this body.

This perspective is used simply to illustrate the principle of projection, while the illustration shown in Fig. 18 is an example of a mechanical projection of the same block, showing the three views in the same plane.

Theoretically, we start with the assumption that the body is located directly under the top plane, and that the top view is projected up to this plane. The end view is projected upon plane A, and this plane is then swung up parallel with the plane of the top view. The same process follows for the side view; it is projected upon plane B, which is swung up parallel with the other two views, all of the views now being in the same plane. In actual practice, the draftsman would lay out the different views in the same relation to each other, but he would simply construct the views by means of his T square, triangles, and scale.

As an aid to remember true projection, and in order to enable the student to ascertain the correctness of his projection drawings regardless of the manner in which the views may be arranged, the following method is recommended.

Observe if the different views bear the same relation to each other as those shown in Fig. 18; that is, that, from the position of the end

view, looking toward the top view, one will see what has been drawn for the end view, and from the position of the side view, looking toward the top view, one will see what has been drawn for the side view. Furthermore, from the position of the top view, looking toward the end view and side view, one can see what has been drawn for the top view.

THE LESSON.—A number of pieces of various shapes are shown on Drawing C-1007, some of the views of each piece being incomplete. The student is expected to lay out a full-size pencil copy of this drawing, with all of the views properly completed.

To finish these correctly it will be necessary for the student to keep in mind what has been written above in regard to proving that the views are properly projected.

Do this work neatly, showing all necessary hidden lines, but remember that the important point is to show a clear understanding of simple projection.

Place all dimensions as shown, and print the title on neatly. Quality, not speed, counts at present in all this work.

In Fig. 1, view C is complete; finish A and B.

In Fig. 2, view B is complete; finish A and C.

In Fig. 3, view C is complete; finish A and B.

In Fig. 4, view C is complete; finish A and B.



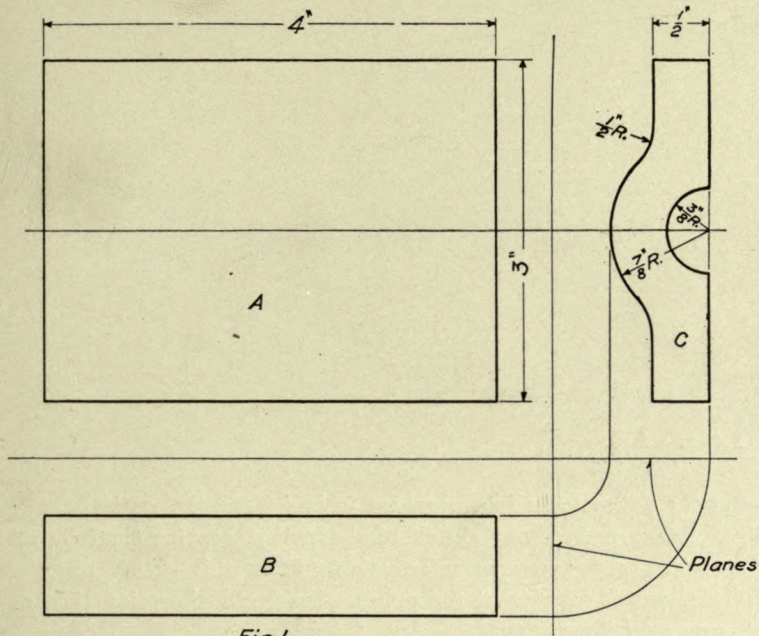

Fig. 1

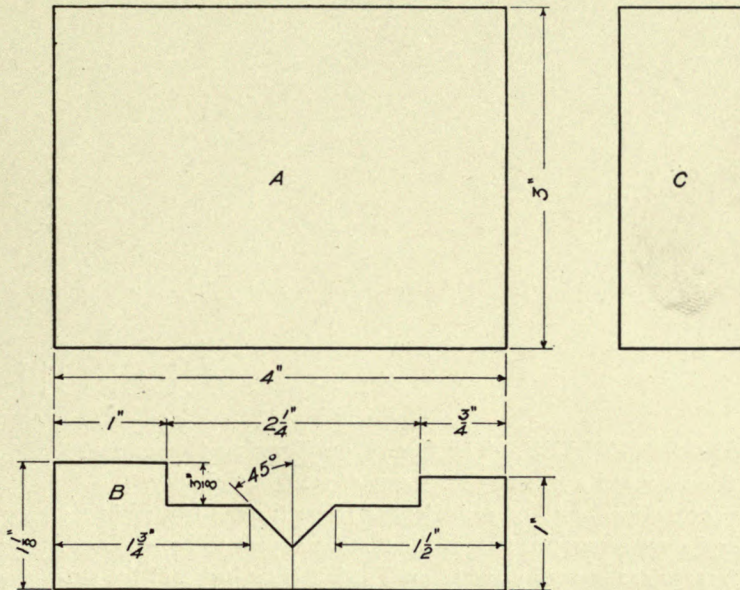

Fig. 2

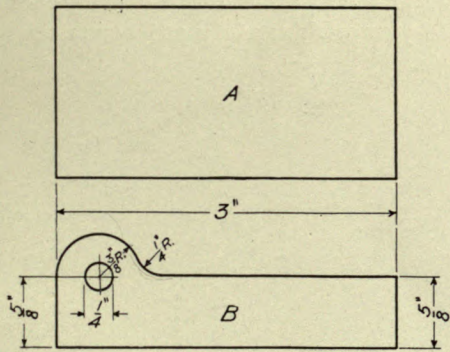

Fig. 3

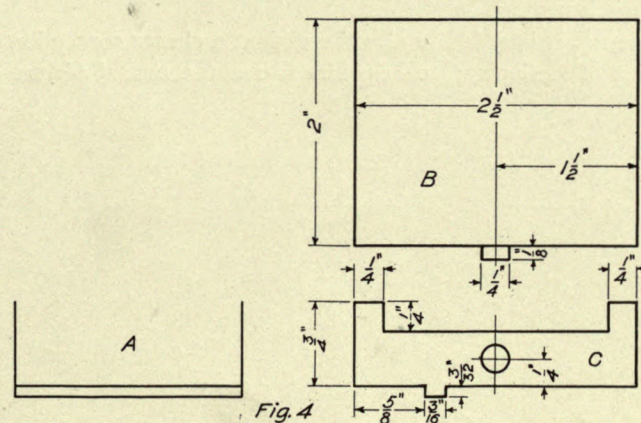
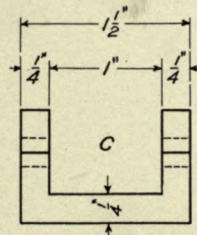

Fig. 4



LESSON No. 13.

FLANGED PULLEY.—The figures on Drawing C-1008 represent a side view and a true sectional view of a Flanged Pulley.

The conventional method of indicating screw threads is used in the holes for the set screws; note that the threads appear to be left hand. These threads are in reality right hand, and it is desired that the student shall reason out for himself just why it is correct to show the threads in this manner.

This lesson is intended to give the student a clearer conception of the subject of sectioning; to help him to make a mental picture of

what the pulley looks like when cut in half along the vertical center line. Make a free-hand sketch of the pulley, copying carefully all dimensions and necessary information. From this sketch make a full-size pencil drawing of the pulley, placing all dimensions just as shown on the illustration.

When dimensioning a drawing, bear in mind that your drawing is to be used as an instrument to furnish exact information to some one in the shop, and unless you do your work carefully and accurately, costly mistakes may be the result.

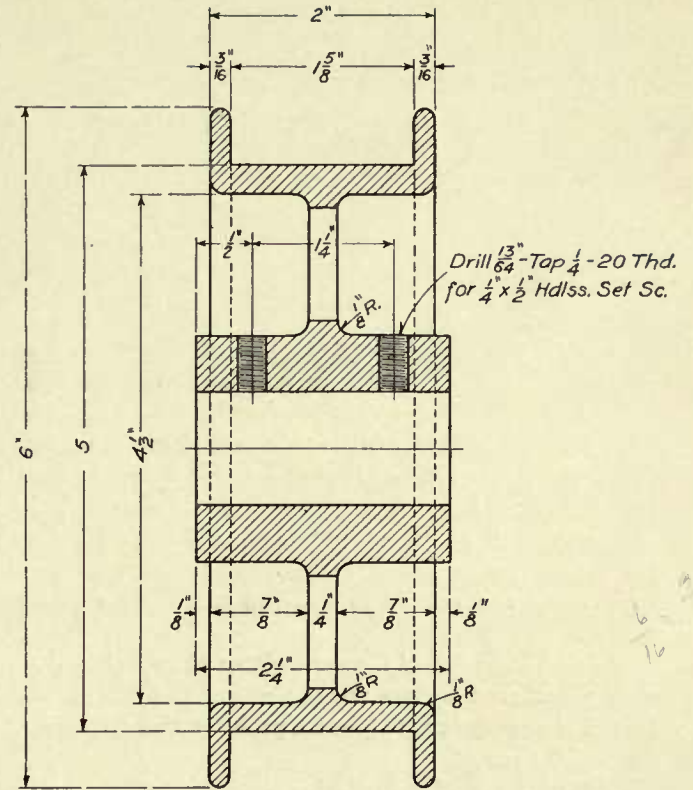
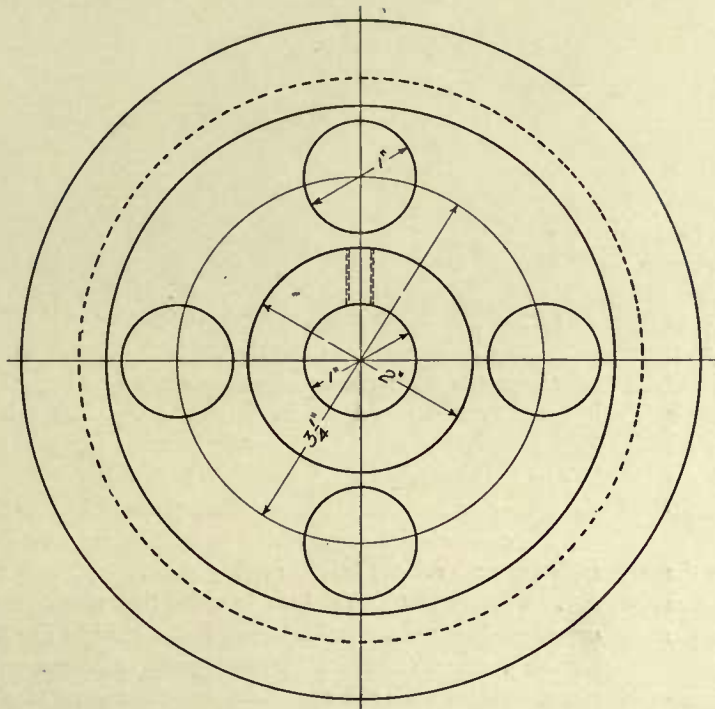

6 - 2/8
1/16

THE CARNEGIE TECHNICAL SCHOOLS
PITTSBURGH, PA.

SCHOOL OF APPRENTICES AND JOURNEYMEN
MECHANICAL DRAWING

FLANGED PULLEY

SCALE Full Size

DWG. No. C-1008

CLASS Industrial TRADE Machinist

NAME John W. Roberts DATE Oct. 16-06.

LESSON No. 14.

HAND WHEEL.—In our previous lessons on sectioning we have dealt with true sections, while, in the present lesson, the sectional view shown of the Hand Wheel is what is called a “conventional section.” In other words, it is not a true section, but a special one which is used because it illustrates the shape of the piece more clearly for the pattern maker and machinist. The draftsman can lay it out more easily and quickly as well—an economy that should be considered.

As an illustration of the convenience of special sections, note the conventional section of the arm of the hand wheel; without this section it would be pretty hard to give the pattern maker a clear idea as to the shape of the arm.

This conventional method of sectioning is used constantly on drawings of such pieces as wheels, pulleys, and gears with arms.

LESSON.—Make a full-size pencil drawing of the Hand Wheel.

Place all dimensions just as shown, with the exception of those that refer to the handle; these dimensions should be left off, as they were intended merely as an aid to the student. Mark this part “No. 2 Handle.” When the pencil drawing is complete, make a tracing of it. Try to do this work neatly; make the lines of the tracing clear and distinct, keeping in mind the instructions given in Lesson No. 9.

When drawing the ball of the handle, *do not* try to make the two radii ($1\frac{1}{8}$ and 1 inch) touch, as they should be joined with a *straight* line. The student should bear in mind that where radii swinging in opposite directions are to be joined, that a straight line should be used for this purpose, otherwise the line appears to have a corner or uneven place. Where the radii are small, as at the stem of the handle, the rule may be overlooked.



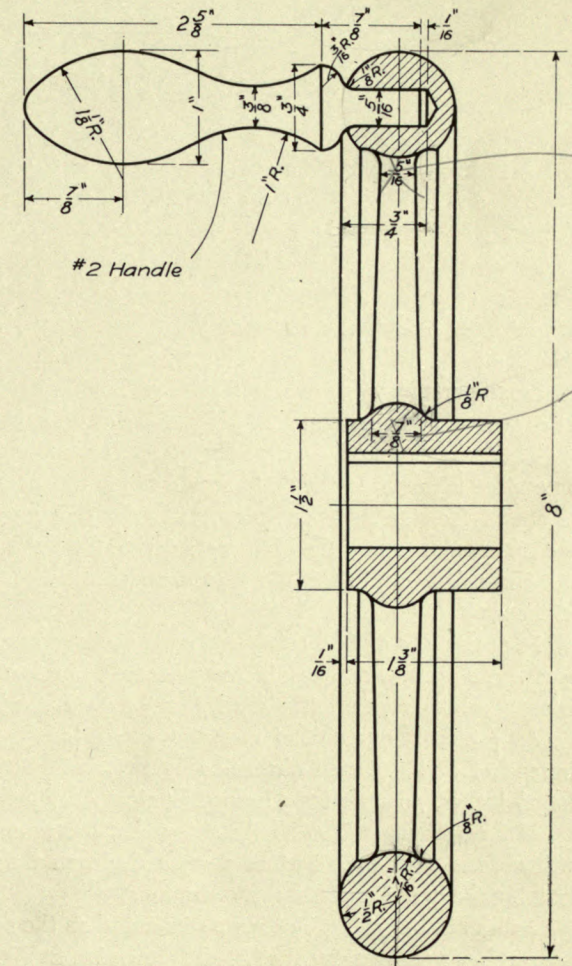
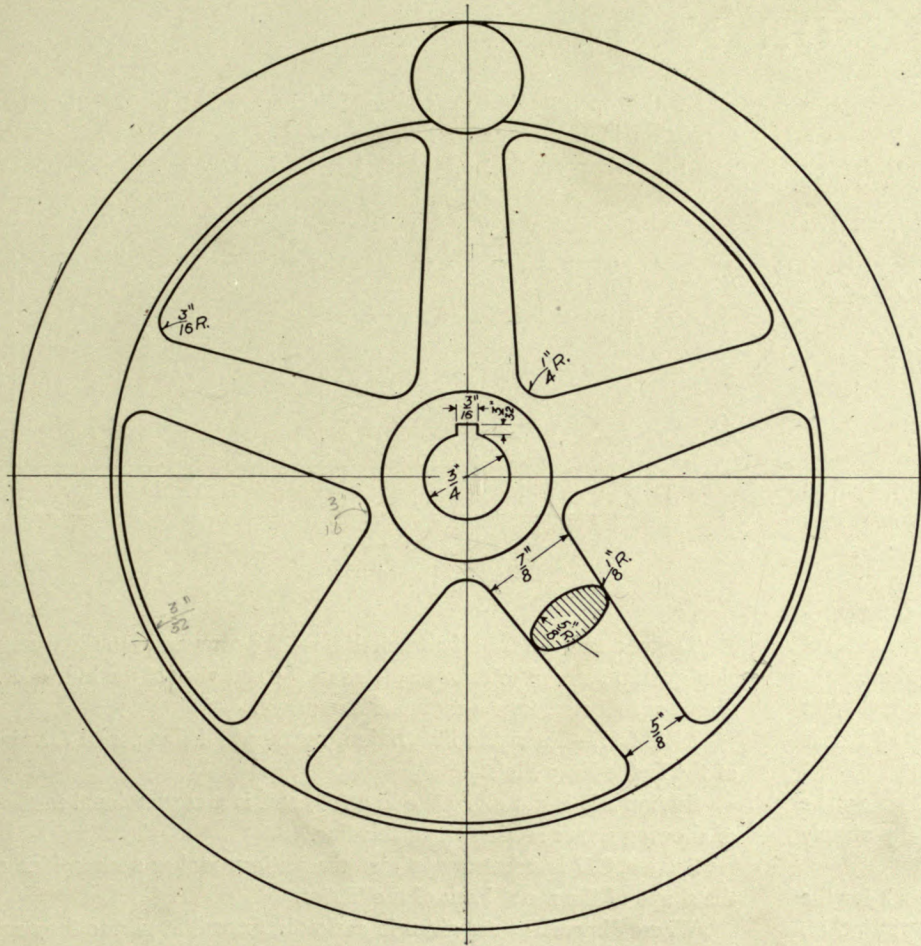

#2 Handle

THE CARNEGIE TECHNICAL SCHOOLS
 PITTSBURGH, PA.
 SCHOOL OF APPRENTICES AND JOURNEYMEN
 MECHANICAL DRAWING

8" HAND WHEEL

CLASS Industrial TRADE Machinist
 NAME John W. Roberts. DATE

SCALE Full Size DWG. NO. C-1009

LESSON No. 15.

DRAWING TO SCALE.—In all of our previous lessons, the pieces illustrated have been drawn full size; in our present lesson we shall take up the subject of drawing objects smaller than full size, or “drawing to scale,” as it is generally termed.

In most modern commercial drafting rooms, the drawings are made on paper of certain sizes. These standard sizes (usually three or four) are adopted to suit the needs of the manufacturer, and each of the machine parts built is shown on one of these standard-size sheets.

Small parts may be drawn full size, but large ones must, of necessity, be drawn to a smaller scale, as $\frac{1}{2}$ size, $\frac{1}{4}$ size, and $\frac{1}{8}$ size.

These are the scales usually adopted by manufacturers of machinery. The piece is drawn to the scale necessary for clearness and best suited to one of the standard-size sheets, while the dimensions are placed in the same manner as if the piece were drawn full size. In other words, the dimensions must show the sizes to which the piece is to be finished in the shop.

In drawing to a given scale, that scale becomes our unit of measurement. As an illustration, take our present lesson, in which the student is expected to make a half-size drawing of the Lathe Face Plate.

As $\frac{1}{2}$ inch is our unit of measurement, $\frac{1}{2}$ inch equals 1 inch, but instead of dividing each dimension by two, read it thus: “ $1\frac{1}{2}$ halves for $1\frac{1}{2}$ inches, 5 halves for 5 inches, $5\frac{1}{2}$ halves for $5\frac{1}{2}$ inch, etc.”

If the student will carefully study the illustration in Fig. 19, he will observe that the divisions can be made on the scale by simply training the eye to perform this operation.

As an aid in readily locating a dimension on the scale, look for the nearest large graduation; the full-size dimension on Fig. 19 is $5\frac{1}{2}$ inches, a thirty-second less than $5\frac{1}{4}$ inches, which figure can be found at once. To find $5\frac{1}{2}$ inches half size, look for $5\frac{1}{4}$ inches half size and point back toward zero one-half of the space between graduations. To locate $5\frac{1}{4}$ inches quarter size, look for $5\frac{1}{2}$ inches quarter size and point back toward zero one-fourth of the space between graduations. $5\frac{1}{8}$ inches one-eighth size is located in the same manner.

By this method it is necessary for the student to keep but one dimension in mind when making a division, and when he learns to read his scale properly, he is much less liable to make mistakes than if he were to make his divisions in the usual way.

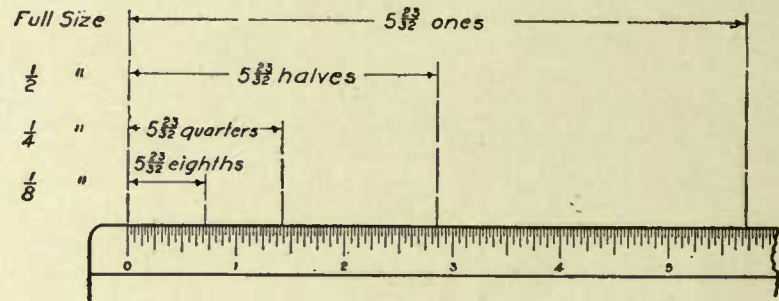

FIG. 19.

To get a radius for half-size circles, set the compasses to the dimension quarter size. For example, to draw the end view of the hub 4-inch diameter half size, take a radius of 4 quarters.

LESSON.—From the illustration, make a half-size pencil drawing of the Lathe Face Plate.

Section AB is cut along the line AB, and is a conventional method of showing a true section along this line.

Section CD is necessary to give the pattern maker a clear idea of the shape of the metal back of the T slot.

Where dimensions are given in decimals, draw that part to the nearest sixty-fourth.

Study the illustration carefully, so as to get a clear idea of the meaning of each line. Do not simply copy; try to make a *mental picture* of the shape of the piece.

Use the edge of your scale, which is graduated in sixteenths, and work from dimensions given.

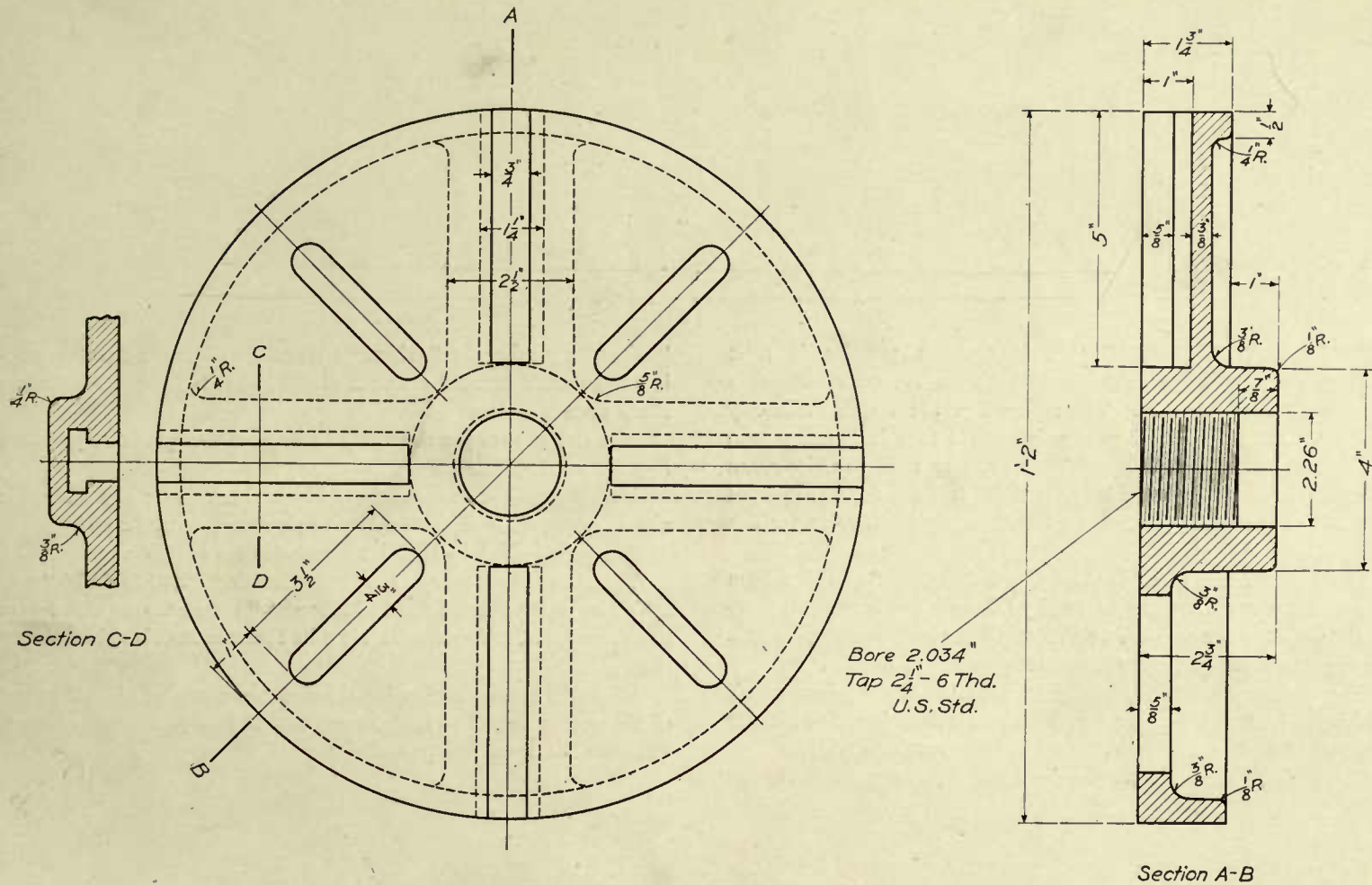

THE CARNEGIE TECHNICAL SCHOOLS
PITTSBURGH, PA.
SCHOOL OF APPRENTICES AND JOURNEYMEN
MECHANICAL DRAWING

LATHE FACE PLATE

CLASS Industrial TRADE Machinist
NAME John W. Roberts DATE Oct. 20. 06.

SCALE 1/2 Size DWG. NO. C_1010

LESSON No. 16.

ASSEMBLY DRAWINGS.—It is common practice in most drafting rooms to make drawings which show several details of a machine fastened together. These drawings are called “assembly drawings,” and they are of great value to the men in the shop who erect or assemble the machines. They are very necessary also when ordering the “stock” or materials from which to build the machines, as the “Bill of Material” contains all the necessary information for this purpose.

The illustration is of a “Positive Clutch Coupling,” so called from the fact that the motion transmitted by this coupling is positive, there being no chance for one-half to slip or slide over the other, as in a coupling where one-half turns the other by means of friction.

The stationary half is keyed tight to the shaft on which it is mounted. The sliding half, which is on a separate shaft, is fitted in such a manner as to slide freely lengthwise on the shaft, while revolving with it.

These shafts are held in line by bearings, one shaft being the

“driver,” the other the “driven.” When the sliding half of the coupling is moved over until the ends of the halves lock together, the two shafts revolve as one.

The end view of the stationary half shows clearly the shape of the lugs for interlocking.

Note the method of indicating a break in the shaft; this method is always employed to indicate a break in a round piece of metal.

LESSON.—Make a half-size drawing of the coupling.

The sizes of keys may be obtained from the “Bill of Material.”

When laying out the “Bill of Material,” use great care with letters and figures, as this information must be accurate and should be clearly shown.

When the pencil drawing is finished, make a tracing of it; the lines of the tracing should be fairly heavy, so that blue-prints made from it will show the figure with perfect clearness.



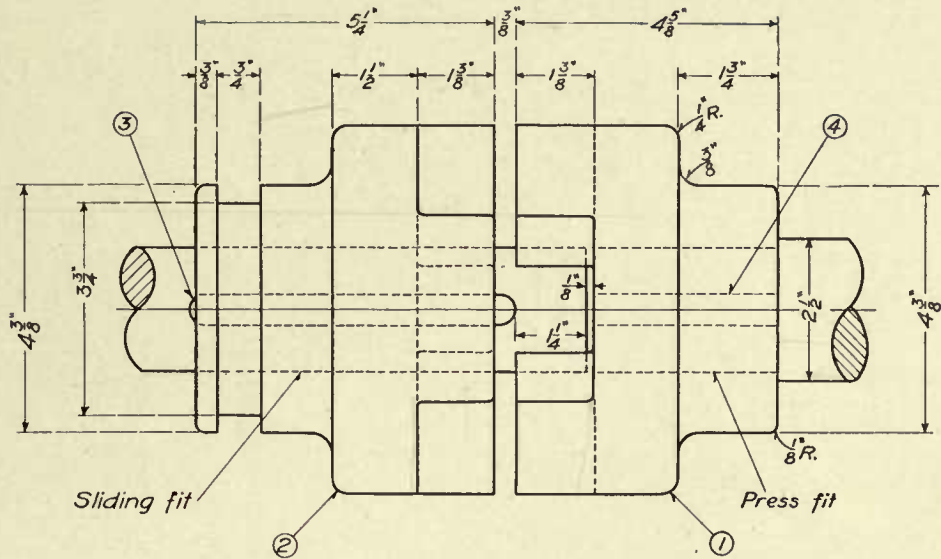
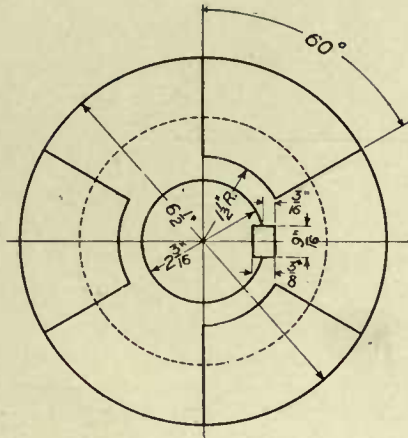

BILL OF MATERIAL

Item No.	Description and Material	Pat. No.	Req.	Notes
①	Stationary Clutch C.I.	A 201	1	$\frac{1}{2}$ $\frac{1}{2}$ $\frac{1}{2}$ $\frac{1}{2}$
②	Sliding Clutch C.I.	"	1	
③	$\frac{3}{8} \times \frac{9}{16} \times 5 \frac{3}{4}$ Feather Key C.R.		1	
④	$\frac{3}{8} \times \frac{9}{16} \times 3 \frac{1}{4}$ Key C.R.		1	

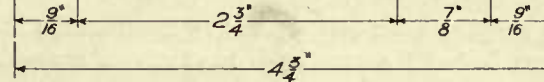

THE CARNEGIE TECHNICAL SCHOOLS
PITTSBURGH, PA.

POSITIVE CLUTCH COUPLING

CLASS Industrial TRADE Machinist

SCHOOL OF APPRENTICES AND JOURNEYMEN
MECHANICAL DRAWING

NAME John W. Roberts DATE Oct. 28. 06.

SCALE $\frac{1}{2}$ Size

DWG. No. C-1011

LESSON No. 17.

COUPLING.—The assembly drawing used for the present lesson is of a “Compression Shaft Coupling.”

This coupling can be clamped around the ends of two shafts, the

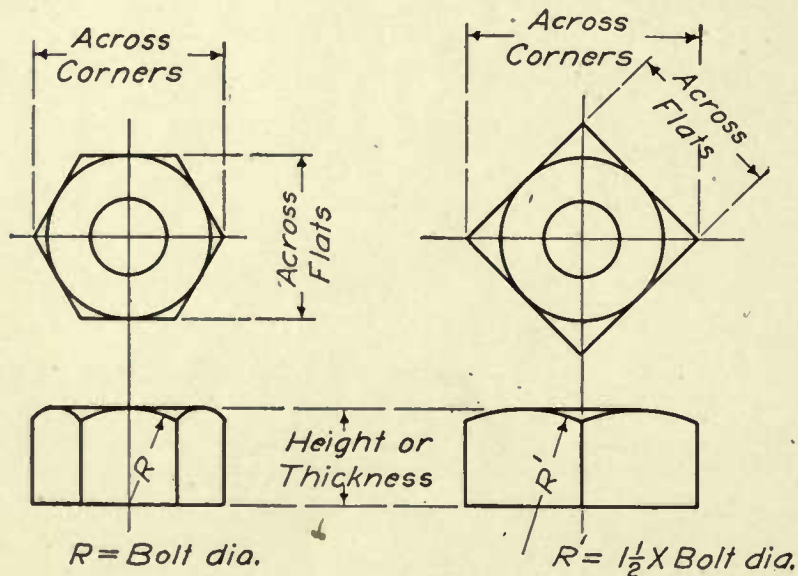

two halves of the coupling being held together by means of the bolts shown. The upper half of the coupling is fitted with a key which keeps the shafts in line.

On assembly drawings it is not customary to give the dimensions of

pins, screws, bolts, and similar details. The sizes only of these small parts are given, so that they can be ordered from the storeroom, where they are kept in stock.

Most modern drafting rooms are supplied with “Data Books” or sheets of stock sizes, from which the draftsmen obtain all necessary dimensions of these small details.

No dimensions are given for the bolts shown in the present lesson, but the student may obtain the size of bolt and nut from the “Bill of Material.”

From the following data the student is expected to calculate for himself all dimensions necessary to draw bolts and nuts to the correct size.

If in doubt as to meaning of terms given below, refer to illustration, Fig. 20.

SIZES OF NUTS AND BOLT HEADS.

Sq.	nuts or bolt heads across flats	=	$1\frac{1}{2} \times \text{bolt dia.} + \frac{1}{8} \text{ inch.}$
“	“ “ “ “ “ “ corners	=	$\text{dia. across flats} \times 1.414.$
Hex.	“ “ “ “ “ flats	=	$1\frac{1}{2} \times \text{bolt dia.} + \frac{1}{8} \text{ inch.}$
“	“ “ “ “ “ corners	=	$\text{dia. across flats} \times 1.156.$
	Height or thickness of nuts	=	bolt diameter.
“	“ “ “ “ bolt heads	=	bolt diameter $\times .80.$

“Length of Bolt” always refers to length *under* the head. Notice Drawing C-1001, Lesson No. 4.

Make a half-size pencil drawing of the coupling, Drawing C-1012.

Remember that accuracy and neatness are points of great importance.

Make a tracing of the finished pencil drawing.

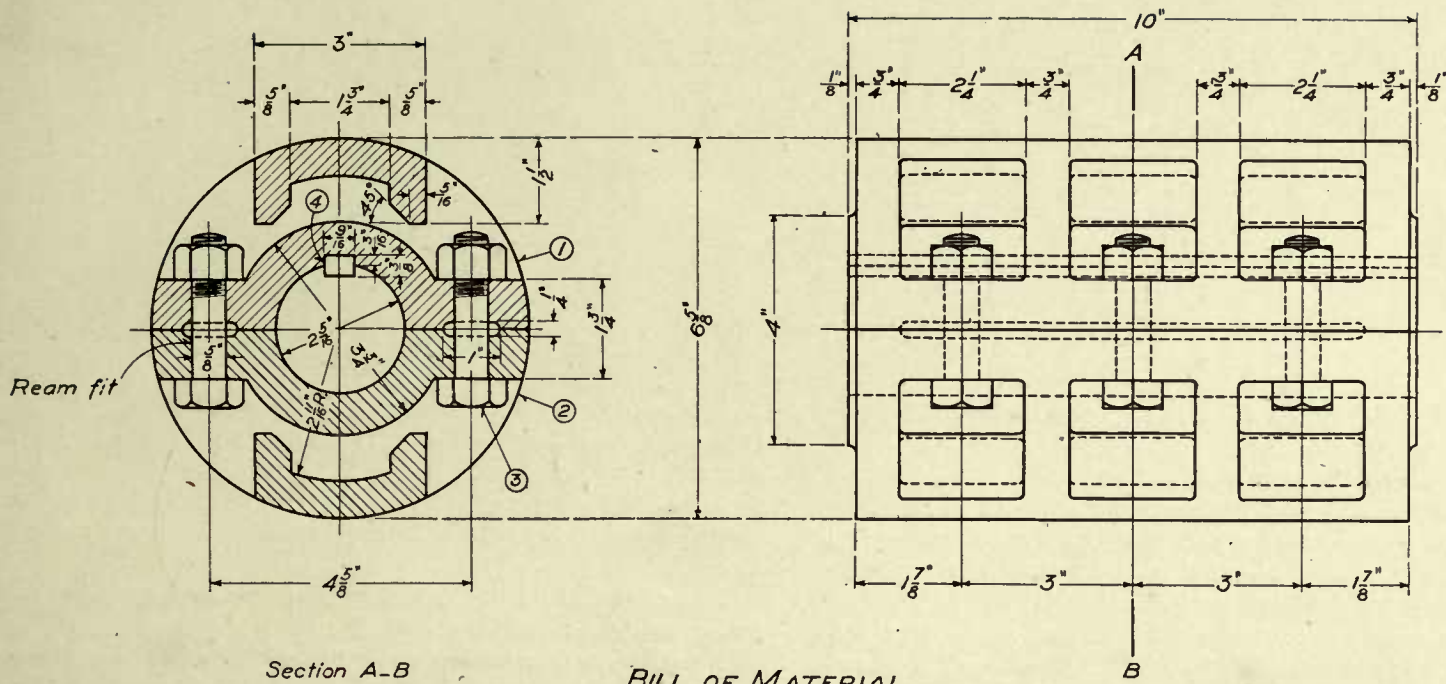

Section A-B

BILL OF MATERIAL

Item No.	Description and Material	Pat. No.	Req.
①	Half Coupling C.I.	A-200	1
②	" " "	"	1
③	$\frac{5}{8} \times 2\frac{1}{2}$ M.B. Tap Bolt with Nut		6
④	$\frac{3}{8} \times \frac{3}{16} \times 10$ Key		1

THE CARNEGIE TECHNICAL SCHOOLS
 PITTSBURGH, PA.
 SCHOOL OF APPRENTICES AND JOURNEYMEN
 MECHANICAL DRAWING

COMPRESSION SHAFT COUPLING

CLASS Industrial TRADE Machinist
 NAME John W. Roberts DATE Oct. 20-06

SCALE $\frac{1}{2}$ Size DWG No. C-1012

LESSON No. 18.

PROJECTION.—Two problems in projection are shown on Drawing C-1013.

(a), Fig. 1, is an end view of a block with all dimensions shown.

(b) is a partly finished front view, showing the length of the block.

View (a) is projected upon a plane which is set at an angle of 45° ; this plane is then raised to a vertical position and swung around one-fourth turn or 90° , so as to show the front view (b).

View (c) should be an end view of the block tilted at an angle of 45° .

Lay out the three views full size, finishing them completely and placing them in the positions indicated on the drawing.

Fig. 2 is a side view of a frustum of a hexagonal pyramid with the base cut away at an angle of 30° .

The small end or top of frustum is $1\frac{1}{4}$ inches across flats, and the large end 2 inches across flats before cutting off a portion of the base, as shown by the dotted line.

The student is expected to lay out the three views of this piece, the top and end views to be placed in the positions indicated on the drawing.

Remember that this lesson is intended purely as a study in projection, and do this work very carefully.

If the student fully grasps the principles of projection, he will have mastered one of the most difficult and most important portions of the subject of mechanical drawing.

It is not necessary to dimension the pencil drawing.



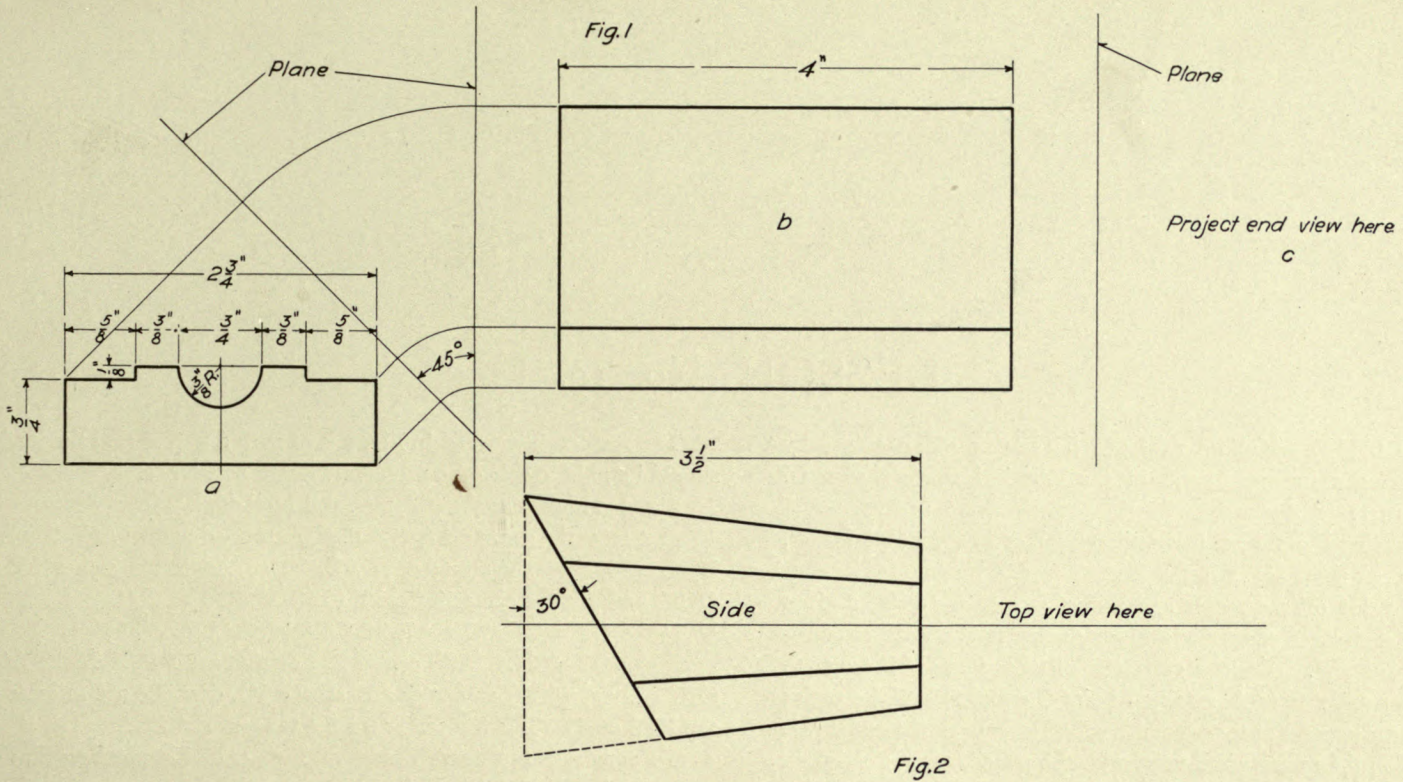

End view here

THE CARNEGIE TECHNICAL SCHOOLS
PITTSBURGH, PA.

SCHOOL OF APPRENTICES AND JOURNEYMEN
MECHANICAL DRAWING

PROBLEMS IN PROJECTION

CLASS Industrial TRADE Machinist

NAME John W Roberts DATE Oct. 10-07

SCALE Full Size

DWG No. C-1013



LESSON No. 19.

THE ELLIPSE.—Make a neat pencil drawing of an ellipse by the three methods indicated, and of the elliptical curve shown on Drawing C-1014.

When drawing the ellipse, make the major or long axis $3\frac{1}{2}$ inches, and the minor or short axis 2 inches in each case.

For Fig. 1, lay off the major and minor axes to the lengths given above; take a straight edge made of any suitable material, as cardboard or wood, and, on one edge, mark off the points AB equal to half the minor axis; from A, mark off point C equal to half the major axis. Place the straight edge so that the point B comes on the major axis and point C on the minor axis; now, with the pencil, mark a point on the drawing paper at A. Shift the straight edge and repeat (keeping B and C on the major and minor axes respectively), placing a sufficient number of points on the paper to enable you to trace a curve through them easily.

The method illustrated in Fig. 2 is of such a nature that the student should be able to solve the problem without assistance.

Fig. 3 is known as the "Three-radii Method."

Construct the rectangle ADCEB. Draw the diagonal AC. Through D, draw DF at right angles to AC. Then, F is the center for arc GCH, and J is the center for arc KAL.

Make $OM=OC$. Describe the semicircle AM.

Make $OP=CN$. With center F, describe arc RPS. Make $AQ=ON$. Then, with J as center and radius JQ, describe arc intersecting arc RPS at T. T is the center for the tangent arc LG.

To construct the curve shown at Fig. 4, divide the base lines of the curve into the same number of equal parts (any number) and connect these division points by straight lines. The combined outer surfaces of these lines form the desired curve.

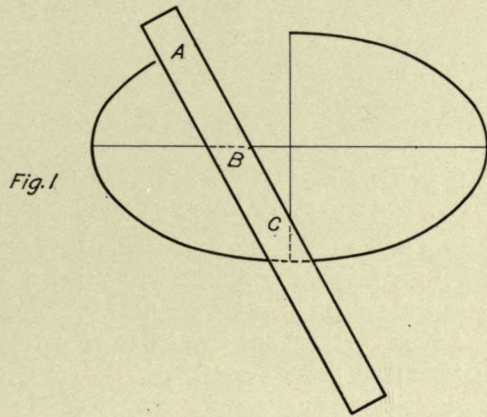

Fig. 1

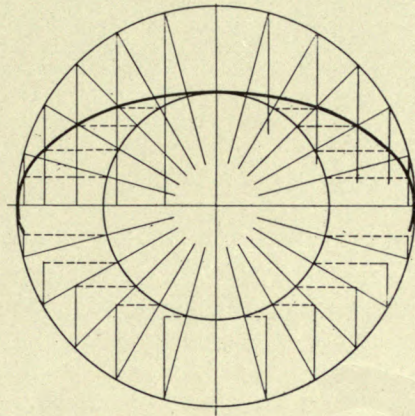

Fig. 2

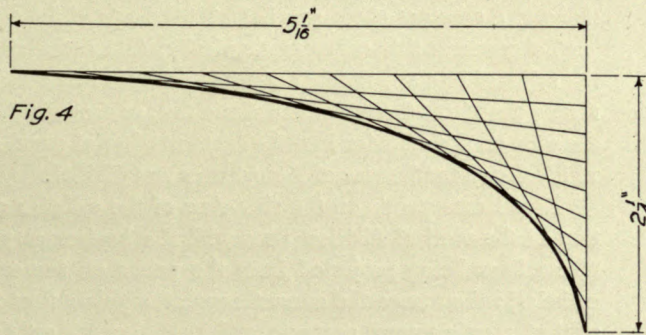

Fig. 4

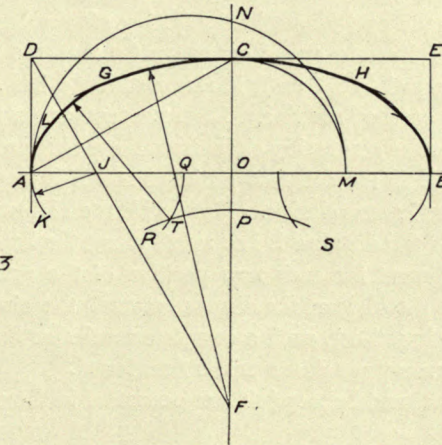

Fig. 3

THE CARNEGIE TECHNICAL SCHOOLS
PITTSBURGH, PA.
SCHOOL OF APPRENTICES AND JOURNEYMEN
MECHANICAL DRAWING

THE ELLIPSE

CLASS Industrial TRADE Machinist
NAME John W. Roberts DATE Dec. 18-06.

SCALE Full Size

DWG. No. C-1014

LESSON No. 20.

ENGINEERING CURVES.—The principle of this lesson is to *generate the path of a moving point*. The curves illustrated are constantly used in engineering work, and a knowledge of their construction should be both interesting and valuable to the student.

The cycloid is the curve generated by a point on the circumference of a circle when rolled along a straight line. When the generating circle is rolled *upon* another circle, an epicycloid will be generated.

When the generating circle is rolled *under* another circle, a hypocycloid will be generated.

To generate the cycloid mechanically, lay off the base and center lines; set the dividers to any short space (so that the length of the chord is about equal to the arc), in this instance $\frac{1}{4}$ inch, and step off 16 or 18 points on the base line. Erect perpendiculars through these points; swing in the generating circle from these different points, so as to place the circle in the different positions which it would assume in making one complete revolution. Now, with the dividers, step off on the second circle the distance it has rolled along the base line, in this case $\frac{1}{4}$ inch. Repeat for each new position of the generating circle (measuring with the dividers the distance around the circle that it has rolled along the base line), until a complete revolution has been made, then trace the curve through the points thus found.

The epicycloid and hypocycloid are generated in the same manner,

the base circle replacing the base line of the cycloid.

The involute is the curve generated by every point in a cord as it is wrapped upon or unwound from a cylinder.

To develop the involute mechanically, unwind a little bit of the cord at a time, and step off upon the line the distance unwound.

Set the dividers to $\frac{1}{4}$ inch and step off 10 or 12 divisions upon the base circle; from these points draw tangent lines to represent the cord in different positions when being unwound.

The helix or screw is the curve which would be generated upon a cylinder revolved at a constant speed against a point, the point moving along at a constant speed parallel with the axis of the cylinder.

To generate this curve mechanically, divide the circumference of the cylinder into any number of equal parts, in this case 25, numbering these points from the left on the center line, as shown. Divide the pitch distance on the cylinder into the same number of equal spaces (25) by which the circumference of the cylinder was divided.

Now locate points on the side view of the cylinder at the intersection of the vertical division lines with the horizontal projection lines (these lines being projected from the points on the end view of the cylinder); then trace the curve through the points thus formed. This subject requires very accurate and careful work on the part of the student.



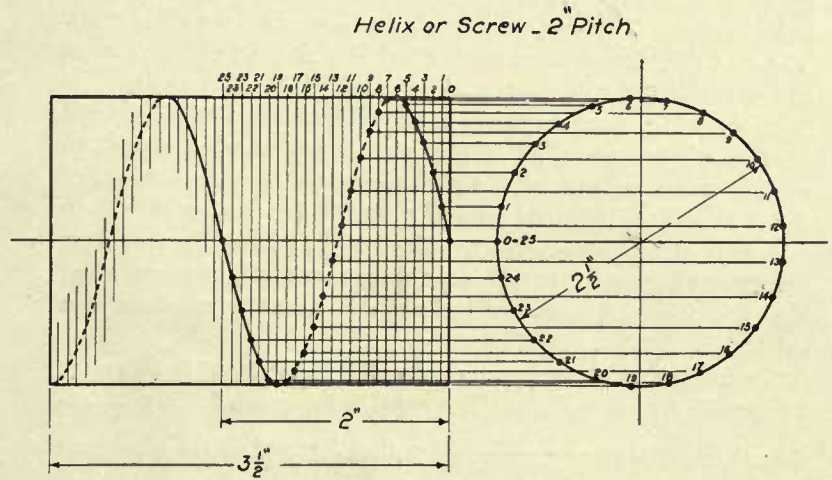
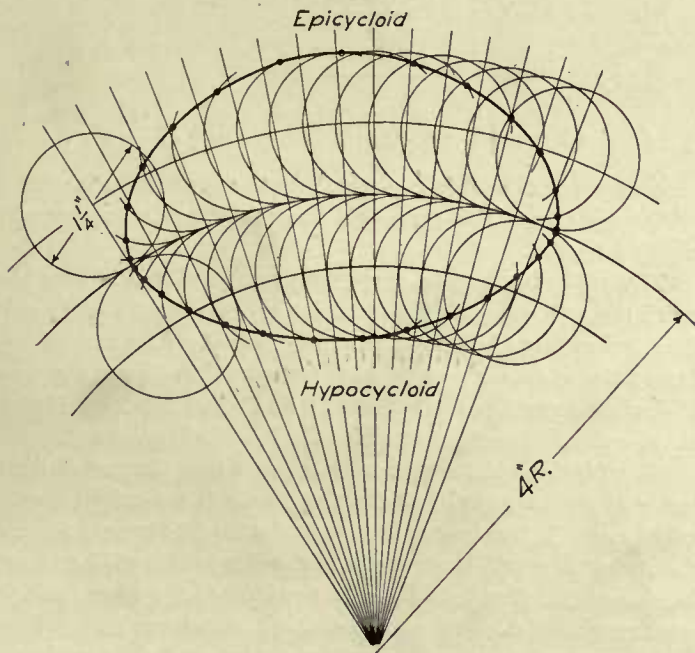
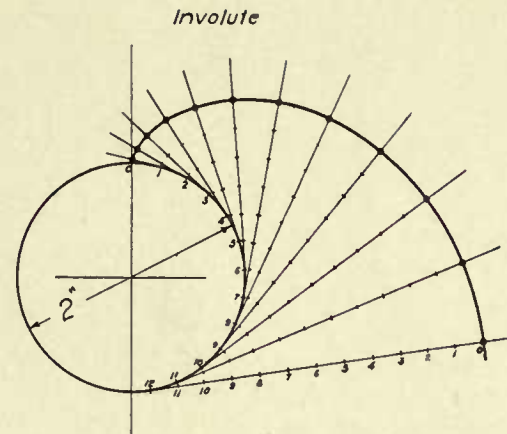
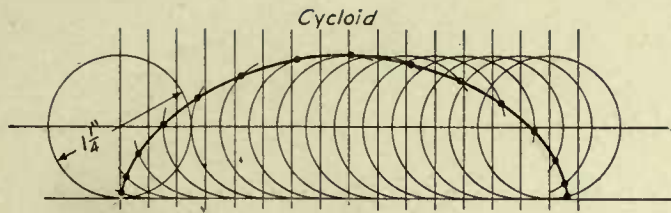

CLASS Industrial TRADE Machinist
 NAME John W. Roberts DATE Feb. 6-07.

THE CARNEGIE TECHNICAL SCHOOLS
 PITTSBURGH, PA.
 SCHOOL OF APPRENTICES AND JOURNEYMEN
 MECHANICAL DRAWING

ENGINEERING CURVES
 THE PATH OF A MOVING POINT
 SCALE Full Size DWG. NO. C.1015



LESSON No. 21.

SPUR GEAR.—From Drawing C-1016 make a full-size pencil drawing of the 24-tooth spur gear illustrated.

The student should study carefully the following memoranda, as he is expected to make use of them in obtaining the sizes of teeth, diameters of gear, etc.

If grooves are cut in the face of a smooth wheel, the parts between the grooves are called *lands*. A part added to a land is called an *addendum*. A land and addendum together is a tooth. Between the teeth are spaces. A toothed wheel is called a *gear wheel*, or simply a *gear*. When the teeth of two gears engage together, the gears are said to be *in mesh*. Two or more gears in mesh are called a *train of gears*. The circumference of the smooth wheel in which the grooves are cut and to which the addenda are added is called the *pitch circle*. The teeth of meshing gears should be so formed that their pitch circles roll together without any slip. The word "diameter" when applied to gears is understood to mean the *pitch diameter*, that is, the diameter of the *pitch circle*. *Diametral pitch* of a gear is the number of teeth to each inch of its pitch diameter. Circular pitch is the distance from the center of one tooth to the center of the next tooth, measured along the pitch circle. A *gear blank* is the wheel before the teeth have been cut into it.

In modern practice the proportions of involute cut teeth are as follows: The tooth thickness, T, is equal to the space, S. The addendum, A, is equal to $\frac{1}{\text{Diametral Pitch}}$; thus for 4 pitch the addendum is $\frac{1}{4}$ inch. The *clearance* is generally made one-eighth of the addendum height; the depth, D, is equal to A, with clearance added.

The radius, R, at the root of the tooth is about one-sixth the dis-

tance B, but varies greatly. The rim thickness, C, is usually made approximately equal to tooth depth.

USEFUL GEAR FORMULAS.—Circular Pitch or C.P. = $\frac{3.1416}{\text{DP}}$.

Diametral Pitch or D.P. = $\frac{3.1416}{\text{CP}}$.

Pitch Diameter = $\frac{\text{Number of teeth}}{\text{DP}}$.

Distance between the centers of two gears = $\frac{1}{2}$ of $\frac{N+n}{\text{DP}}$.

N = number of teeth in large gear; n = number of teeth in small gear.

Outside diameter of gear, or diameter of blank, = number of teeth in gear + $2 \div \text{D.P.}$

The particular involute curve most generally used in gear teeth is called the 15° involute. To construct it: Describe the pitch circle of the required gear and draw a line tangent to it. At the tangent point, draw a line at an angle of 15° to the tangent line. From the center of pitch circle, draw a circle tangent to the 15° line; this is called the base circle, and is the circle upon which the involute is generated.

When laying out the gear teeth, observe that the part of the tooth inside of the base circle, or the *flank*, as it is generally termed, is a radial line. It is necessary to lay out the involute curve but once, for the student may set his compasses to a radius (which will be an approximation to this curve), to throw in the faces of the other teeth. This work requires the utmost care to obtain accurate results.

When pencil drawing is complete, make a good clear tracing.

Where the dimensions are not shown, the student is expected to use the formulas given to obtain the necessary figures.

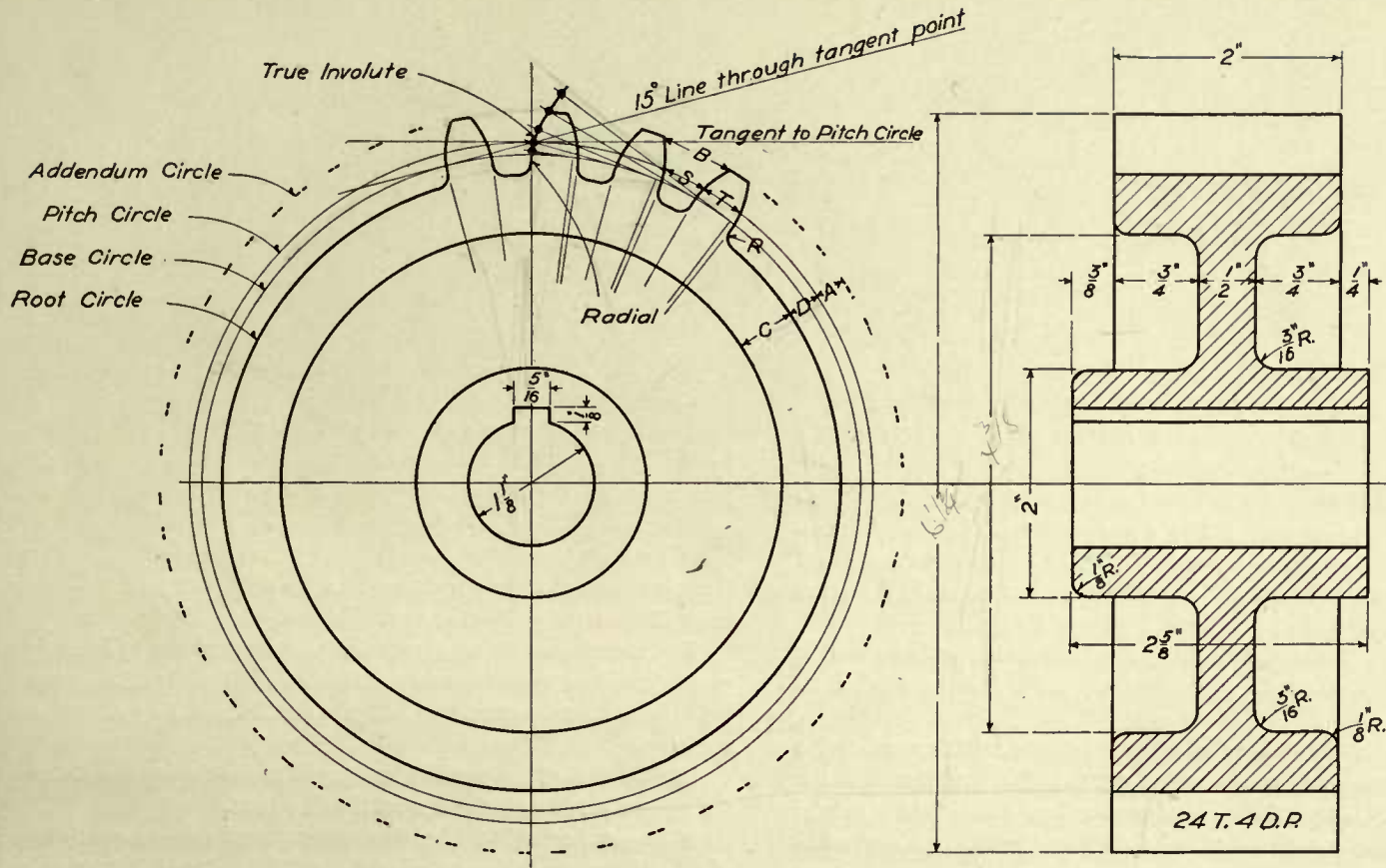

THE CARNEGIE TECHNICAL SCHOOLS
PITTSBURGH, PA.

SPUR GEAR

CLASS Industrial TRADE Machinist

SCHOOL OF APPRENTICES AND JOURNEYMEN
MECHANICAL DRAWING

NAME John W. Roberts DATE Mar. 20-07

SCALE Full Size

DWG. No. C-1016

LESSON No. 22.

INTERSECTIONS.—The important principle contained in this lesson is the projection of a *point*.

From Drawing C-1017, make a full-size pencil drawing of the intersecting cylinders and their developments.

The curve formed by the intersection of the two cylinders is found point by point as shown by points 2 and 4 on the illustration. The oval shown in the end view is formed by cutting the large cylinder off at an angle of 30° with the horizontal plane; it is found in the same manner as the curve of intersection.

If the student studies the illustration carefully, he should be able to follow out the method of projecting a point from one view to another.

As the end views of the cylinders are the only views on which the true circumference can be obtained, it naturally follows that it is the end view in each case that should be used to locate the division points.

The circumference of the cylinder may be divided into any number of points, and those points projected upon the other views to obtain the desired curves.

DEVELOPMENT.—The student should try to realize that a surface is composed of a series of lines.

The different methods of developing a surface are usually described by the kinds of lines used for this purpose. As an instance, in our present lesson we use *parallel* lines to develop the surfaces of the cylinders.

If we were to cut the large cylinder through at point C, and were then to spread it out flat, we would have a duplicate of the development of the large cylinder shown.

For the reasons given above, the end view of the cylinder is the proper place to obtain the true length of the development, assuming that the student is unable to find the circumference by simple arithmetic.

The lengths of the various lines used in developing the surface of the pattern may be obtained from the side view.

It is very desirable that each student should make a careful study of this subject, as a thorough knowledge of the principle involved will be of value when drawing difficult shapes.



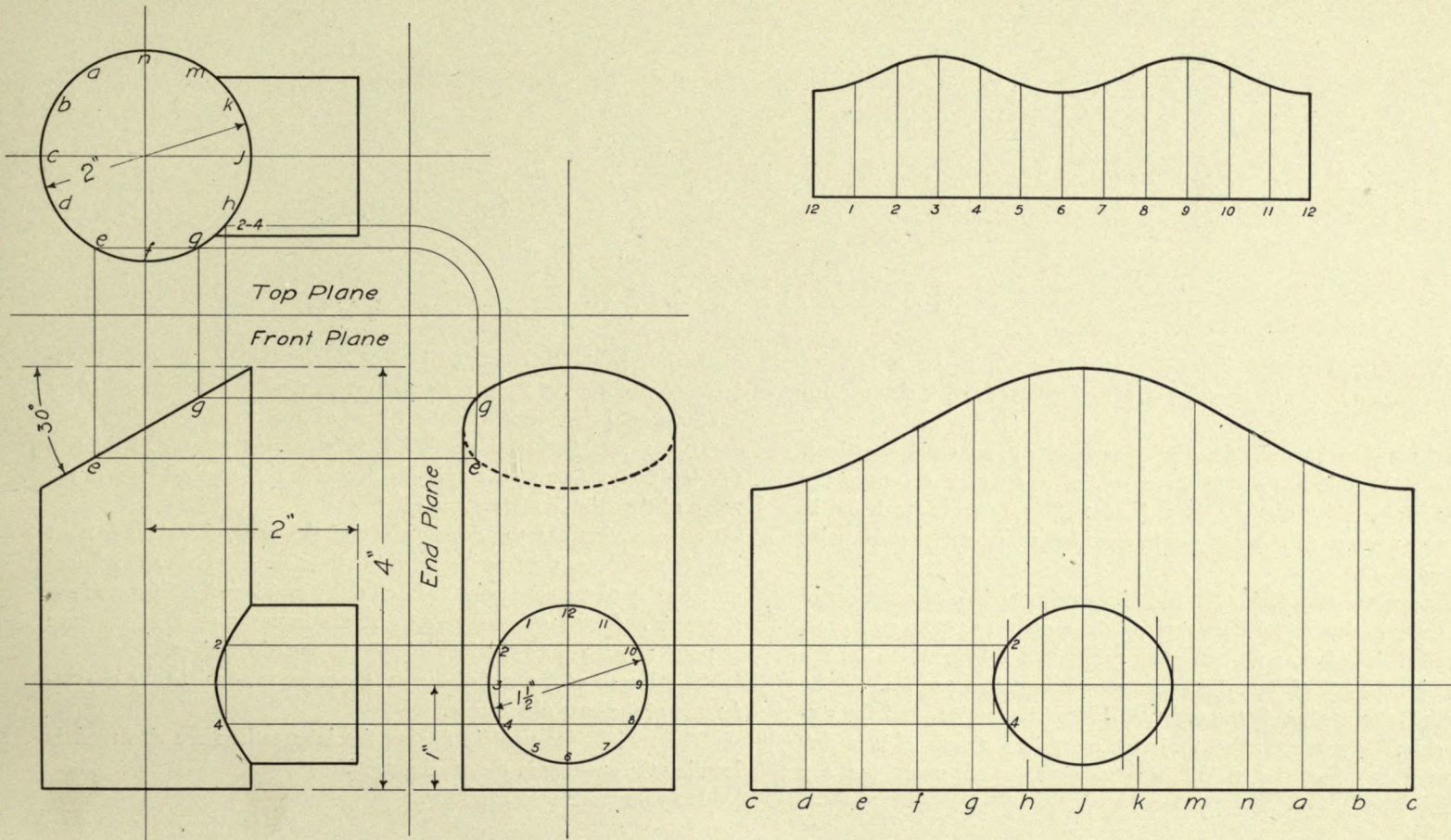

THE CARNEGIE TECHNICAL SCHOOLS
 PITTSBURGH, PA.
 SCHOOL OF APPRENTICES AND JOURNEYMEN
 MECHANICAL DRAWING

INTERSECTIONS AND DEVELOPMENTS
 PARALLEL LINE DEVELOPMENT
 SCALE Full Size DWG. No. C-1017

CLASS Industrial TRADE Machinist

NAME John W. Roberts DATE April 20-07.

LESSON No. 23.

INTERSECTIONS.—From Drawing C-1018, make a full-size pencil drawing of the intersecting cone and cylinder and their developments.

If the student has fully mastered the previous lesson on intersections, he should be able to develop the curves of intersection shown in the top and front views of the present lesson. These curves are found in the same manner as those of the intersecting cylinders; that is, point by point.

The student may divide the end of the cylinder into any number of points, then draw radial lines through these points. Or he may draw the radial lines first, and then place points at the intersections of the lines with the end of the cylinder, as shown by points 1 and 4.

The latter method is the one used in the illustration, and the student should observe that to project these points 1 and 4, it is *first* necessary to have the radial line 1-4 projected upon the top view.

RADIAL-LINE DEVELOPMENT.—In our last lesson the surfaces of the figures were composed of parallel lines, the method of development being named from the kind of lines used.

In our present lesson we find it necessary to use radial lines to develop the surface of the cone, from which this method derives the name of "Radial-line Development."

When laying out the development of the cone, the student must bear in mind that the true length of the lines on the cone can be found on the sides of the cone only, as in all other positions the lines are foreshortened. Thus to get the true distance from the apex of the cone to point 1, this point must be projected to one of the sides.

The length of the arc of the development is equal to the circumference of the base of the cone.

The radial lines used in finding the intersections are also used in locating the opening in the development.

Do your work very carefully.



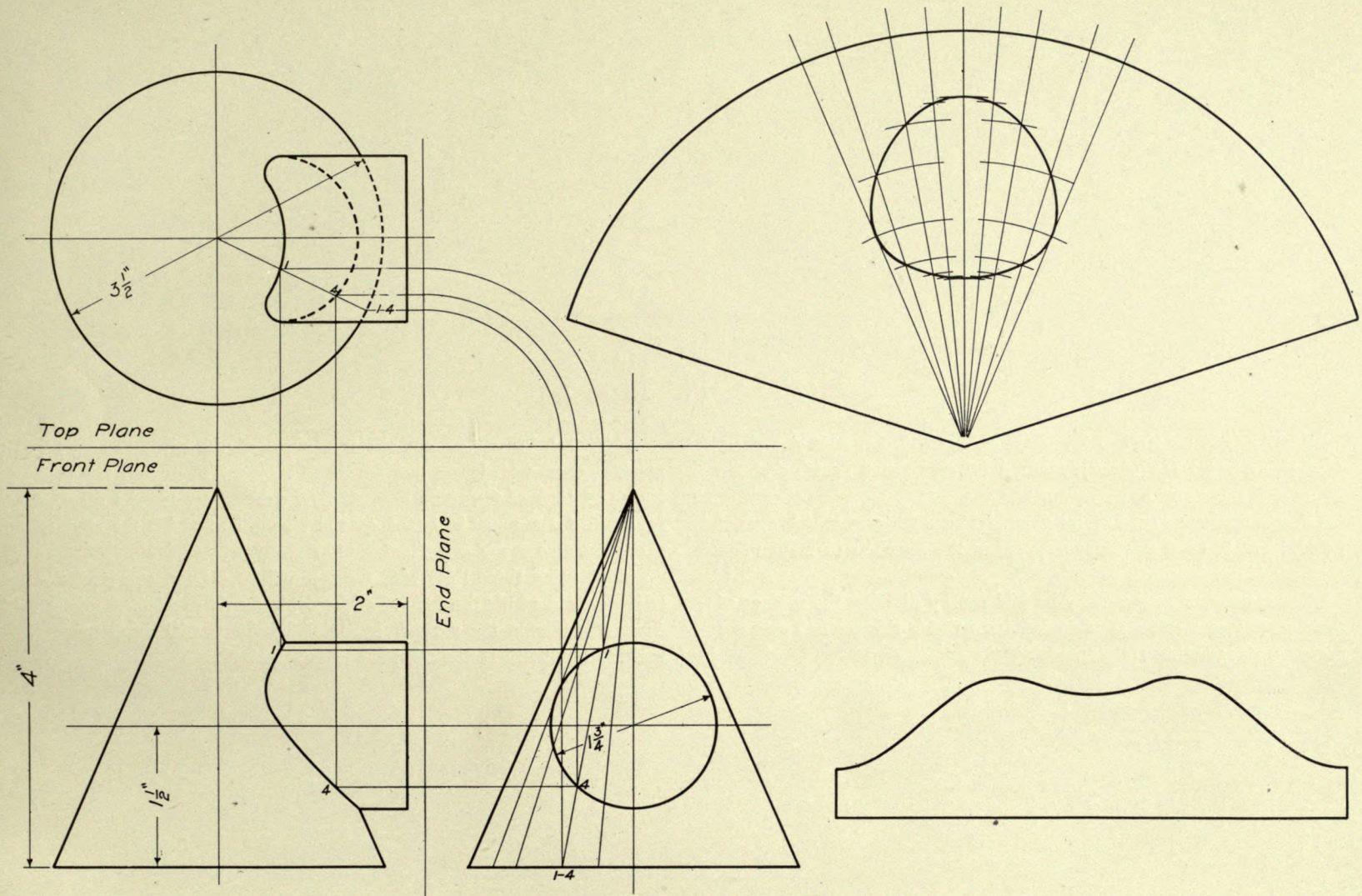

CLASS Industrial TRADE Machinist
 NAME John W. Roberts DATE April 26_07.

THE CARNEGIE TECHNICAL SCHOOLS
 PITTSBURGH, PA
 SCHOOL OF APPRENTICES AND JOURNEYMEN
 MECHANICAL DRAWING

INTERSECTIONS AND DEVELOPMENTS
 RADIAL LINE DEVELOPMENT
 SCALE Full Size DWG. No. C.1018

LESSON No. 24.

TRIANGULATION DEVELOPMENT.—Upon a B-size sheet of drawing paper (15"×22"), make a full-size pencil drawing of the Transition Piece and its development.

Sheet-metal workers require a great many patterns which cannot be laid out to good advantage by either the Parallel- or Radial-line methods of development.

These patterns may usually be laid out by dividing the surface of the figures into a series of triangles, from which this method gets the name "Triangulation Development."

LESSON.—First lay out the two views of the piece illustrated, marking them with letters and figures as shown. Then find the true length of each of the slope lines ABCD, etc. These lengths may be found in the manner indicated on the illustration, which the student should be able to understand without help.

Now, using these lines with the top and base lines, construct the triangles into which the figure had been previously divided. Connect these triangles in the manner indicated by the partial development, and the result will be the complete pattern desired.

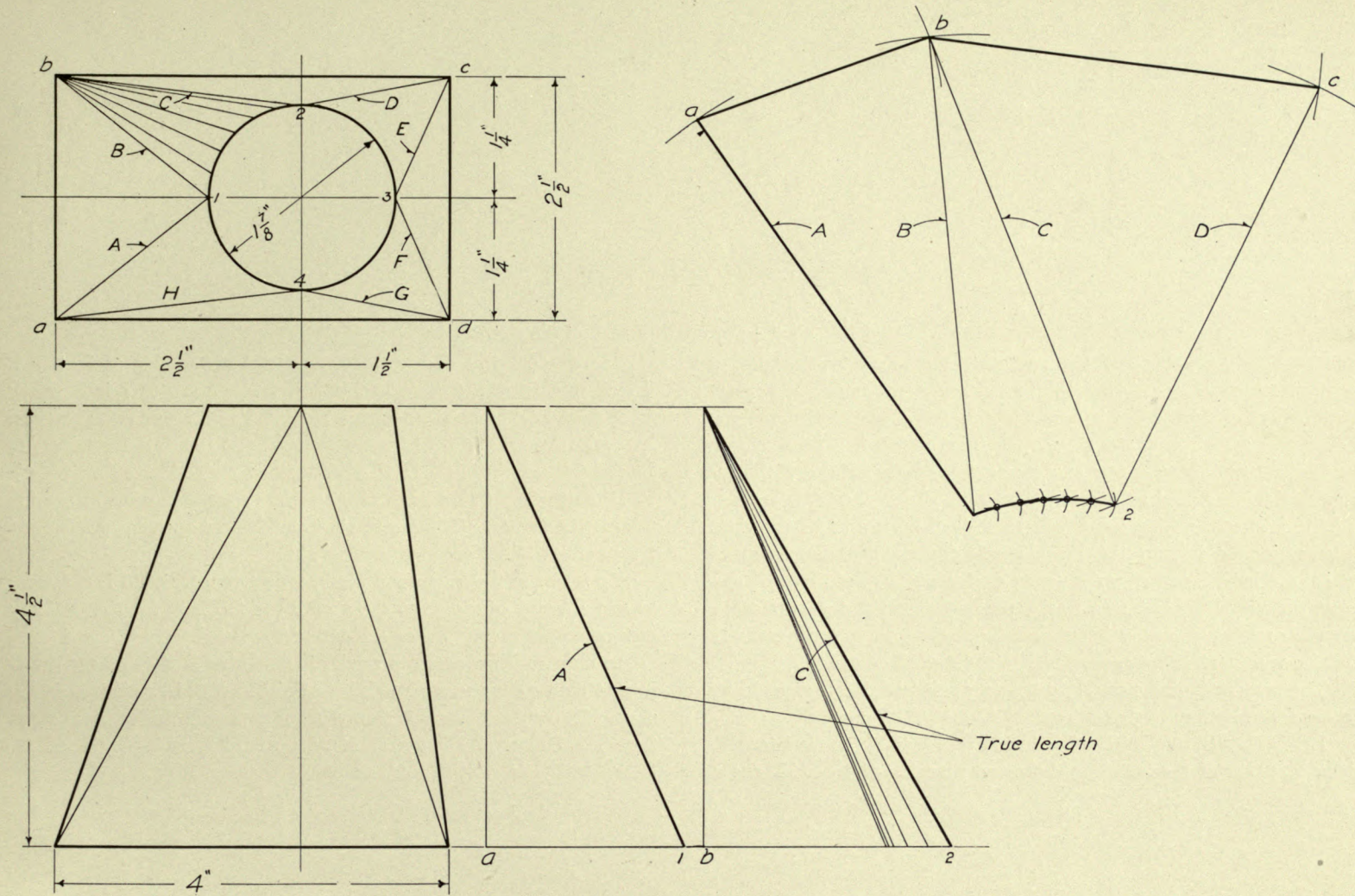

CLASS Industrial TRADE Machinist
 NAME John W. Roberts DATE May 6_07.

THE CARNEGIE TECHNICAL SCHOOLS
 PITTSBURGH, PA.
 SCHOOL OF APPRENTICES AND JOURNEYMEN
 MECHANICAL DRAWING

INTERSECTIONS AND DEVELOPMENTS
 TRIANGULATION DEVELOPMENT
 SCALE Full Size DWG. No. B_1019

LESSON No. 25.

VALUE OF PRACTICE.—From the previous lessons the student should have become familiar with the general principles of mechanical drawing. With this assumption in mind, the main requirement of the student is now to obtain sufficient practice, making detail and assembly drawings, to help him to become proficient in turning out rapidly work that is accurate, with the lettering and dimensioning done in a neat and attractive manner.

No modern drafting room will send out blue prints of drawings upon which the lettering has been poorly done, or the dimensions of which are indistinct. Many a young draftsman has been refused employment simply because he was a poor letterer. If the applicant's sample drawing is neatly lettered and dimensioned, the chances are that he will be given an opportunity to show what he can do.

The student is expected to do the very *best* work he is capable of, on the following working drawings.

DETAIL DRAWING.—The present lesson is a quarter-size detail drawing of the lathe leg shown on Drawing C-1020. Make a

tracing of the finished pencil drawing.

The student will observe that the metal of the side of the leg is $\frac{3}{8}$ inch thick near the back, and that it tapers down to $\frac{1}{4}$ inch at the front edge. This is shown in the top view, and is for two purposes: To make the casting light but strong, and also to allow the pattern to be easily lifted out of the sand when making molds in the foundry.

The openings in the back of the leg are for the purpose of making the casting lighter. The $\frac{1}{4}$ -inch rib around these openings strengthens the casting without adding much weight.

To throw in the large radii given, the student will find it necessary to use a beam compass, as these radii are too long for the ordinary compass, even though the extension bar were used.

In most drafting rooms a mark of some kind is used on the drawings to indicate that a surface is to be finished, that is, machined in the shop. The "finish mark" shown on the present lesson is adopted from the Universal Dictionary of Mechanical Drawing by Prof. G. H. Follows

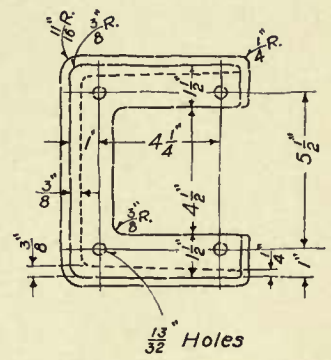
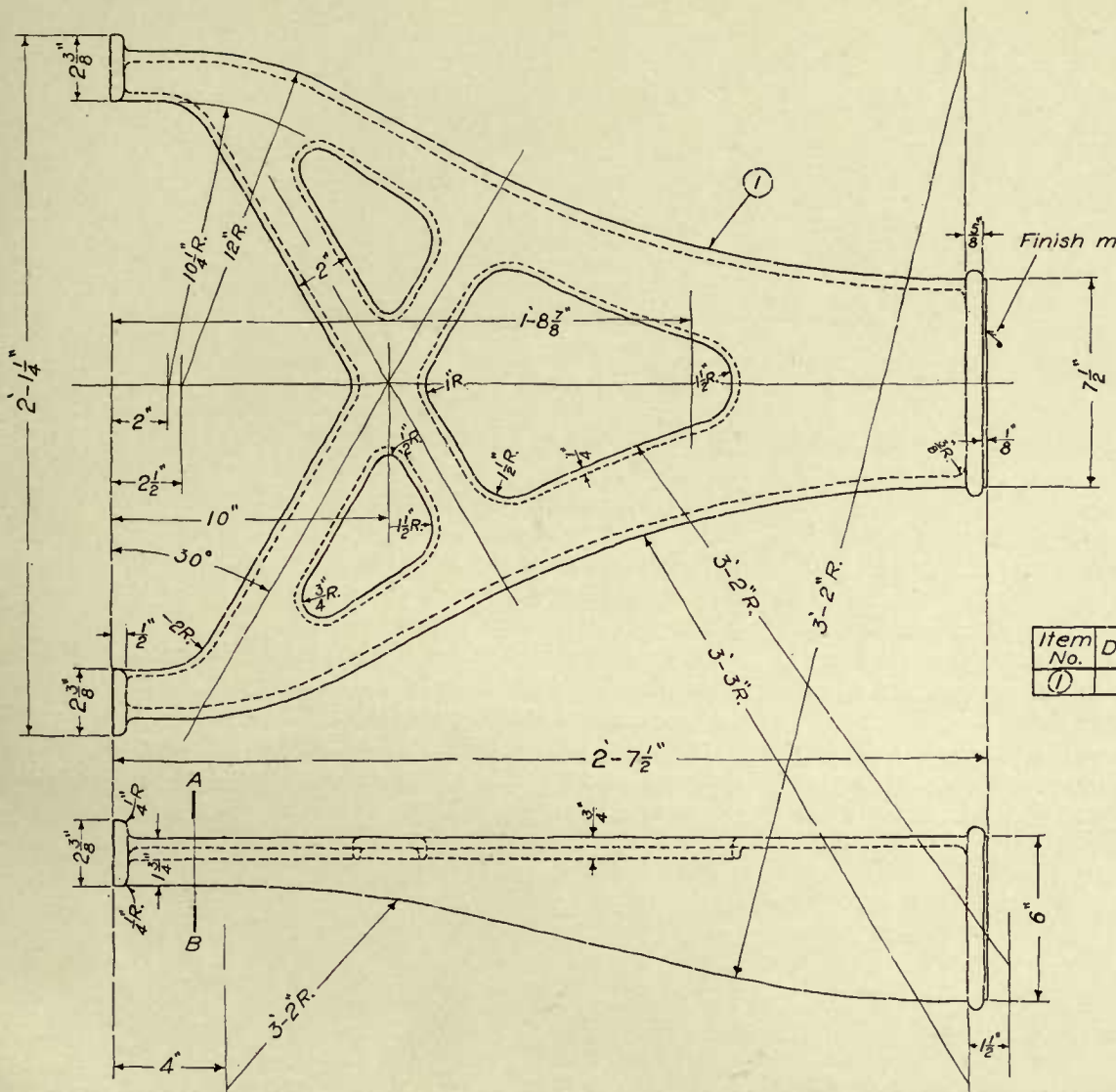

BILL OF MATERIAL

Item No.	Description and Material	Pal. No.	Req.
①	Leg C.I.	70	2

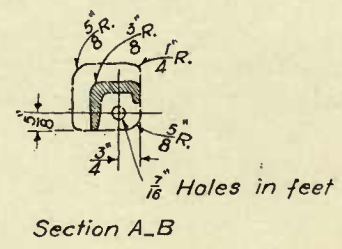

THE CARNEGIE TECHNICAL SCHOOLS
 PITTSBURGH, PA.
 SCHOOL OF APPRENTICES AND JOURNEYMEN
 MECHANICAL DRAWING

12" SPEED LATHE
LEG DETAILS
 SCALE 1/2 Size DWG. No. C-1020

CLASS Industrial TRADE Machinist
 NAME John W. Roberts DATE May 8-07.

LESSON No. 26.

LATHE BED.—Make a half-size pencil drawing of the lathe bed shown on drawing C-1021. Make a tracing of the finished pencil drawing.

This drawing shows the method commonly used to take care of pieces which are too large for standard-size sheets; this method is to show the piece "broken," as it is termed.

The lathe bed shown is five feet long, and to show it without "breaking," or the complete bed, would necessitate that it be drawn to a very small scale, so small, in fact, that the views would not show to the best advantage what the drawing was intended to show.

By breaking away part of the bed, we are able to draw it to a larger scale and show more clearly its shape and size. The part broken away is of no value to any one using the drawing, as it is similar to the rest of the bed adjoining the break.

Observe carefully all notes and dimensions, and see that none are overlooked, as full information must be furnished on working drawings.

The cap screws referred to in the "Bill of Material" are for bolting the legs to the bed.

The broken views of the top and bottom of the bed are intended to show more clearly the shape of the corners, the sizes of fillets, and to show the position of bolt holes.

The student should refer to the leg drawing, C-1020, if he desires to see whether the positions of the clearance holes in the top view of the leg correspond to the tapped holes in the bottom of the bed.

Observe the method of using the "finish mark" shown at the top of the end view. This indicates that the whole surface between marks is to be finished.



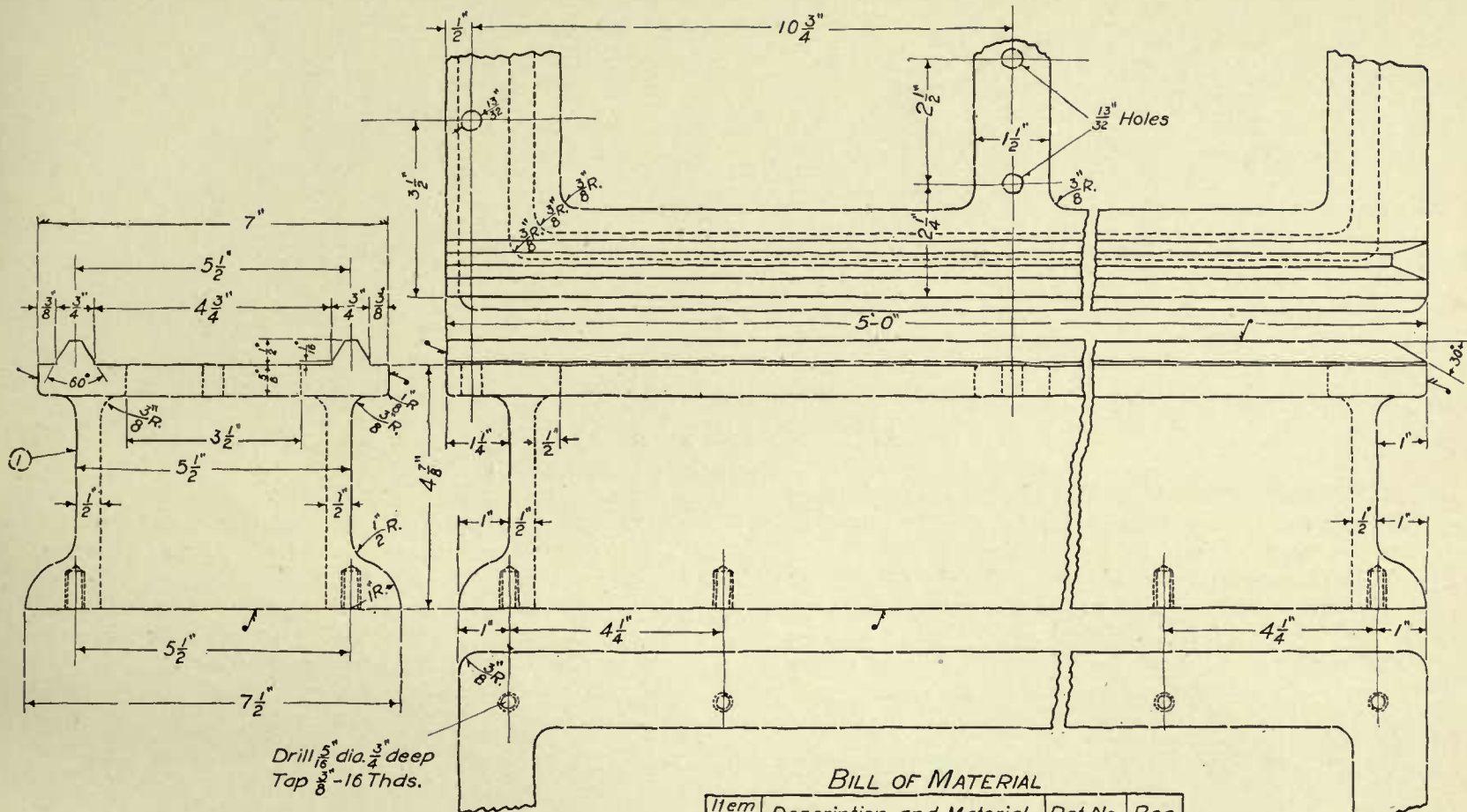

BILL OF MATERIAL

Item No.	Description and Material	Pat. No.	Req.
①	Bed C.I.	71	1
②	$\frac{3}{8}$ X $1\frac{1}{2}$ " Hex. Hd. Cap Sc.		8

CLASS Industrial TRADE Machinist
NAME John W. Roberts DATE May 10-07.

THE CARNEGIE TECHNICAL SCHOOLS
PITTSBURGH, PA.
SCHOOL OF APPRENTICES AND JOURNEYMEN
MECHANICAL DRAWING

12" SPEED LATHE
BED DETAILS
SCALE $\frac{1}{2}$ Size DWG. No. C.1021

LESSON No. 27.

TOOL-REST DETAILS. — Most of the parts or details of a speed-lathe tool rest are shown on Drawing C-1022; part of these details are drawn half size, and the rest full size.

Make an accurate pencil drawing and tracing of the details shown.

The hand wheel is very similar to one drawn in an earlier lesson, with the exception that it is an "offset" wheel, that is, the rim is not central over the arms, but set to one side. The necessary radii with the location of their centers are shown, so that the student should be

able to draw this hand wheel without difficulty.

When drawing the arms of the hand wheel, bear in mind what was said in the earlier hand-wheel lesson, in regard to using a straight line for the purpose of joining two curves.

Do not overlook any of the dimensions on the various details, for you must remember that you are furnishing the man in the shop with the necessary information to machine these parts correctly.

Use great care with the lettering and figures.



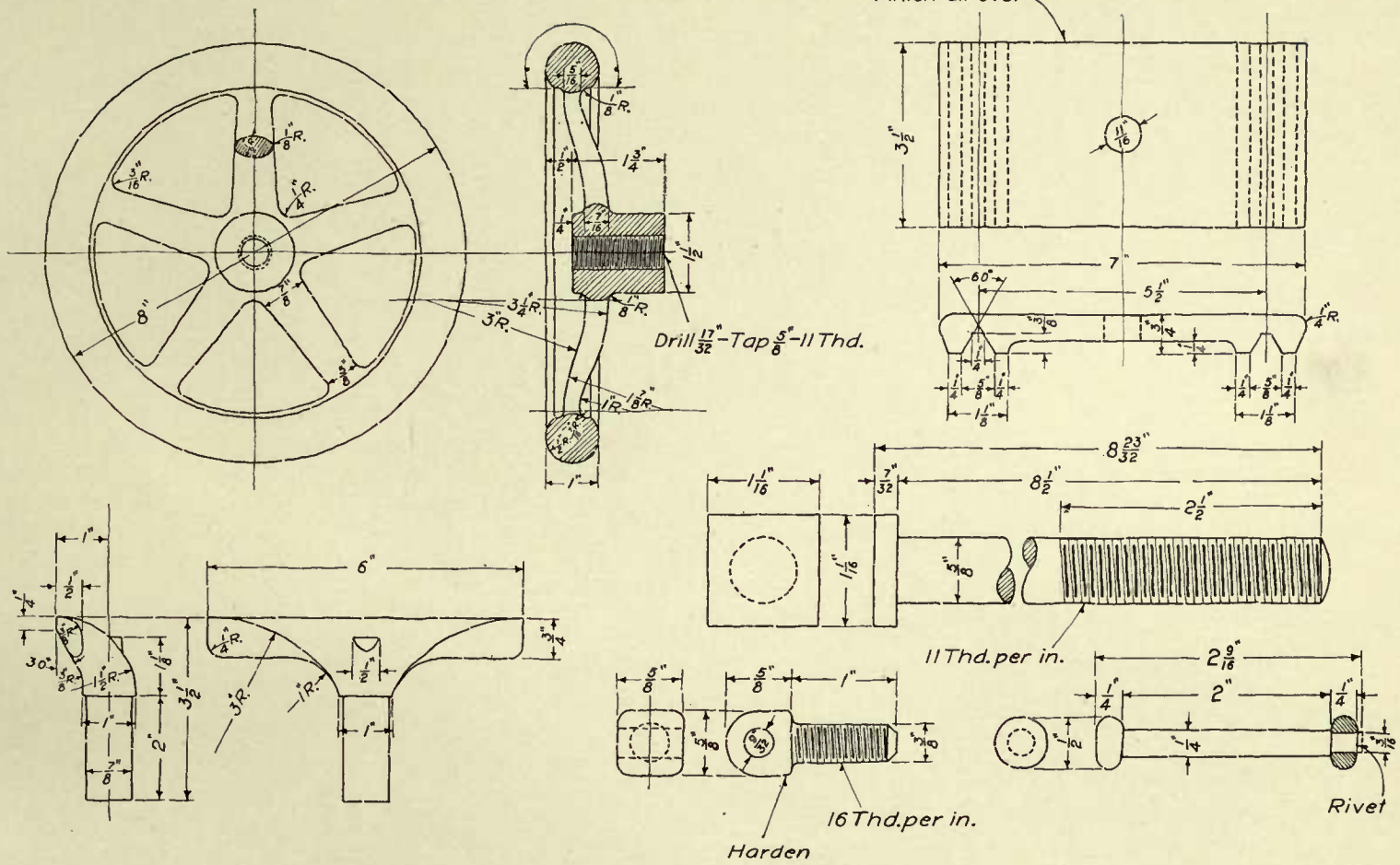

THE CARNEGIE TECHNICAL SCHOOLS
 PITTSBURGH PA.
 SCHOOL OF APPRENTICES AND JOURNEYMEN
 MECHANICAL DRAWING

12" SPEED LATHE
 TOOL REST DETAILS
 SCALE $\frac{1}{2}$ " & Full Size DWG. No. C-102P

CLASS Industrial TRADE Machinist
 NAME John W. Roberts DATE Dec. 12-07.

LESSON No. 28.

TOOL-REST ASSEMBLY.—Drawing C-1023 is an assembly drawing of the complete tool rest.

This drawing is used for the purpose of showing how the different parts are fastened together, or assembled, as it is termed.

The only parts dimensioned are the stand and clamp, all of the other details being machined from Drawing C-1022. This assembly drawing is, therefore, used as a detail drawing also, as the stand and clamp may be machined from it.

When drawing the parts that are not dimensioned, the student must necessarily refer to the detail drawing to obtain the sizes needed.

Study the drawing carefully so as to obtain a clear understanding of the meaning of each line. Do not simply copy the various lines because they are shown on the original; satisfy yourself as to their meaning.

Think for yourself.



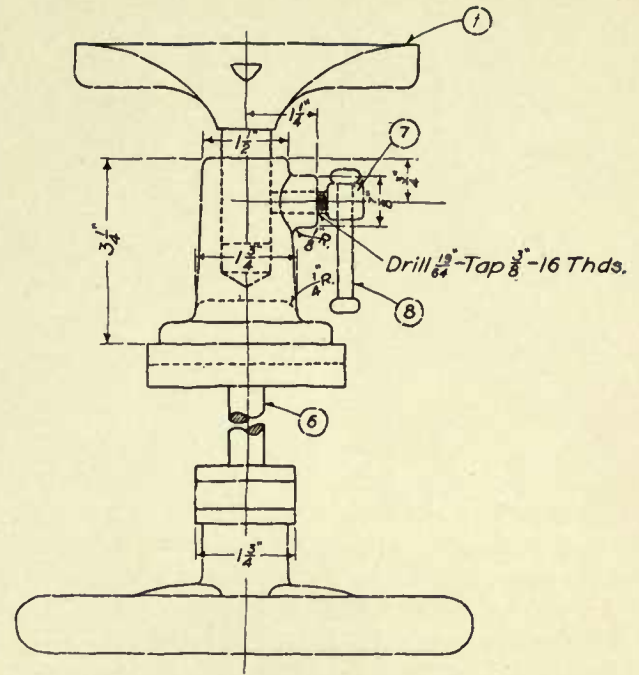
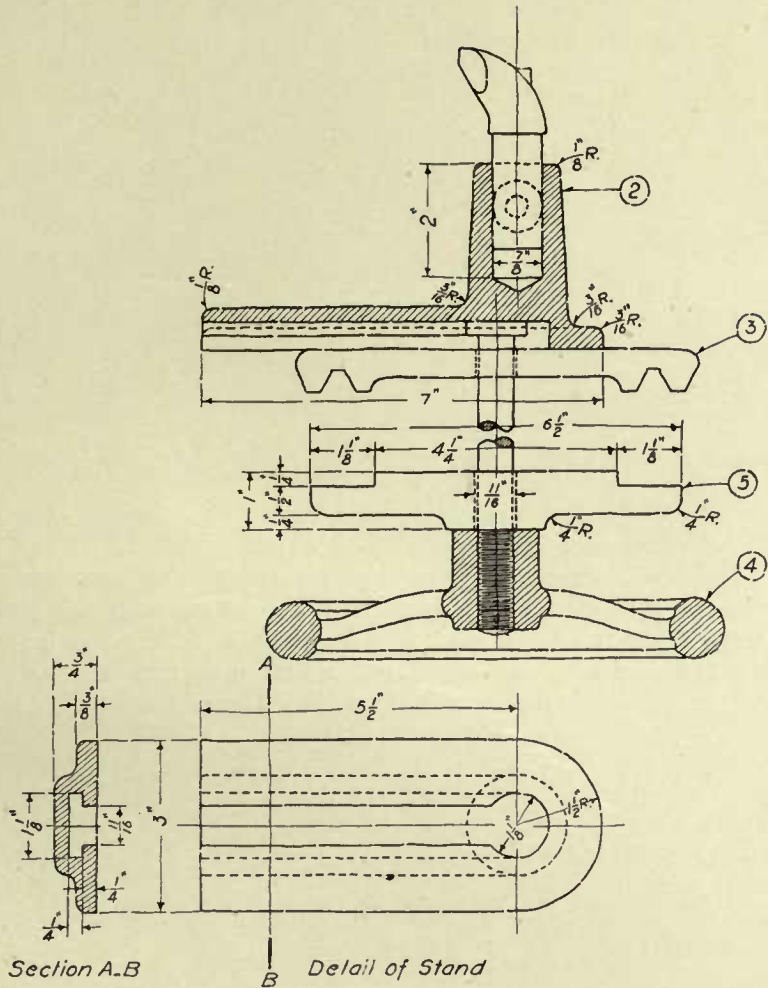

BILL OF MATERIAL

Item No.	Description and Material	Pat. No.	Req.
①	Tool Rest, C.I.	79	1
②	" " Stand, C.I.	80	1
③	" " Base, C.I.	81	1
④	" " Hand Wheel, C.I.	82	1
⑤	" " Clamp, W.I.		1
⑥	Clamp Bolt, W.I.		1
⑦	Adjusting Screw, C.R.		1
⑧	Adj. Screw Lever, C.R.		1

THE CARNEGIE TECHNICAL SCHOOLS

PITTSBURGH, PA.

SCHOOL OF APPRENTICES AND JOURNEYMEN
MECHANICAL DRAWING

12" SPEED LATHE TOOL REST ASSEMBLY

SCALE 1/2 Size

DWG. No. C-1023

CLASS Industrial TRADE Machinist

NAME John W. Roberts DATE Dec. 24-07.

LESSON No. 29.

TAILSTOCK DETAILS.—Part of the details of a lathe tailstock are shown on Drawing C-1024.

The sectional view of the spindle shows the taper bore in one end, and the method of fastening the bronze nut in the other end.

The end of the spindle is bored to a taper of $\frac{5}{8}$ inch per foot, or the "Morse Taper," a name by which this particular taper is known in shops and drafting rooms. By a taper of $\frac{5}{8}$ inch per foot, we mean that a cylindrical piece 12 inches long and 1 inch in diameter at the small end will be $1\frac{5}{8}$ inches in diameter at the large end. In other

words, the piece is $\frac{5}{8}$ inch larger in diameter at one end than at the other.

By this time the student should be sufficiently familiar with hand wheels to need no instruction on this subject.

The binding screw shown is an illustration which shows the value of a knowledge of shop practice. This screw is machined in a lathe in the manner shown by the solid lines; after being finished, it is placed in a special forming tool, where it is bent to the shape shown by the dash lines. Make a tracing of the finished pencil drawing.

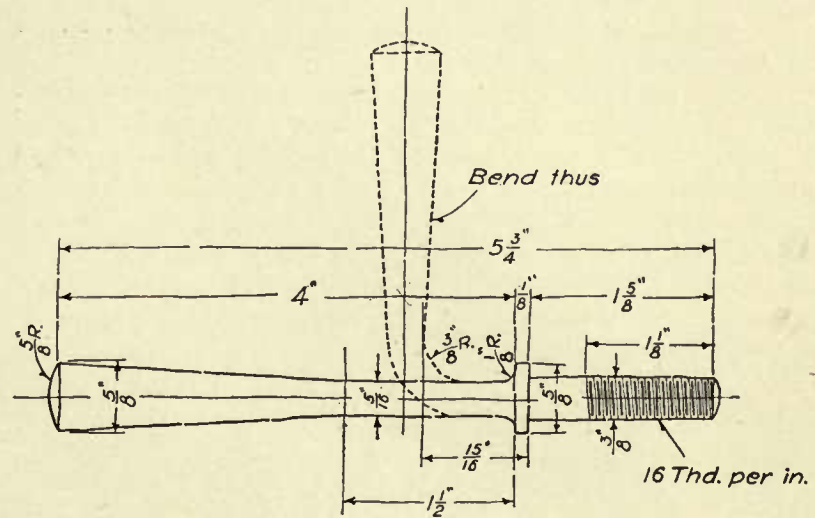
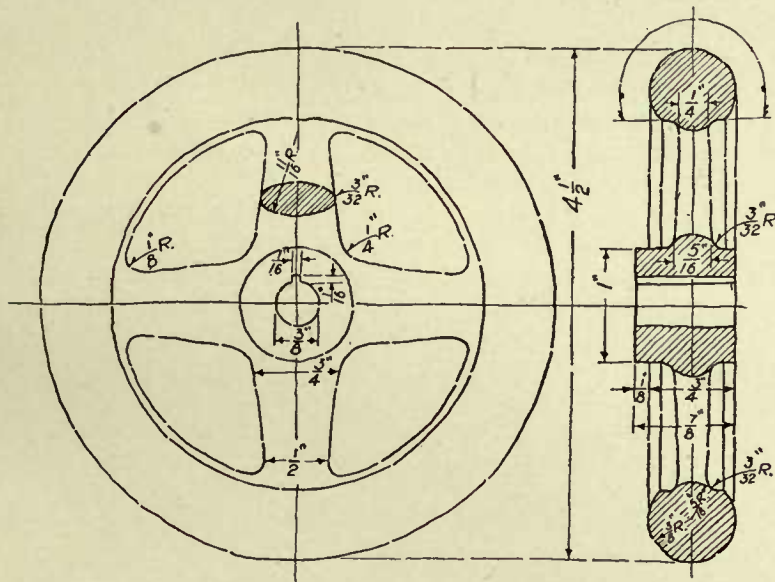
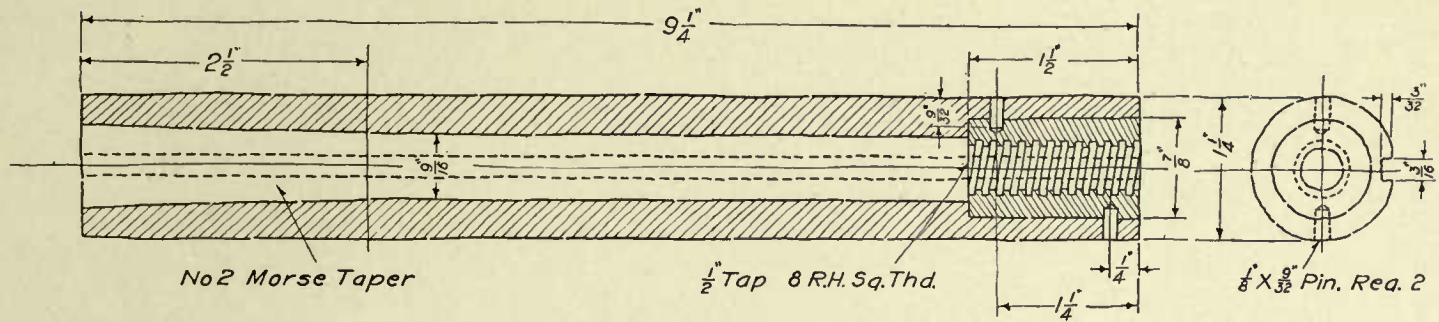

THE CARNEGIE TECHNICAL SCHOOLS

PITTSBURGH, PA.

SCHOOL OF APPRENTICES AND JOURNEYMEN

MECHANICAL DRAWING

12" SPEED LATHE
TAILSTOCK DETAILS

SCALE Full Size

DWG. No. C-1024

CLASS Industrial TRADE Machinist

NAME John W. Roberts DATE Dec. 30. 07.

LESSON No. 30.

TAILSTOCK DETAILS.—The rest of the details of the lathe tailstock are shown on Drawing C-1025.

The small spindle key is used to prevent the spindle from revolving.

The square-thread screw is used to move the spindle in and out of the tailstock barrel. The manner in which the thread is shown on this screw indicates that it is to be cut the full length to the collar. The main object in showing the thread in this manner is to save the draftsman's time.

The small key set into the stem of the screw is known as a Woodruff key. This key resembles a portion of a washer driven into a slot

milled in the screw.

From the rules given in a previous lesson, the student can obtain the dimensions necessary to draw the hexagon nut.

The wrench shown is used to tighten the nut on the clamp bolt, thus fastening the tailstock to the bed.

The tailstock plug, or bell, as it is usually termed, supports the spindle screw.

The small steel oiler is used to drop oil on the centers. Make a pencil drawing and tracing of this lesson. Do the very best work you are capable of.



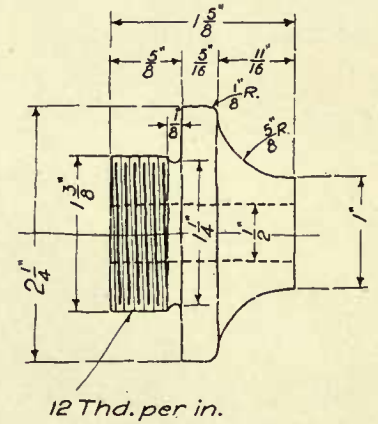
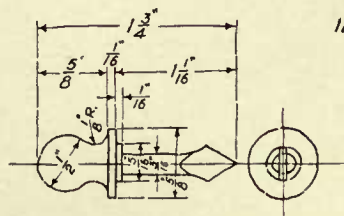
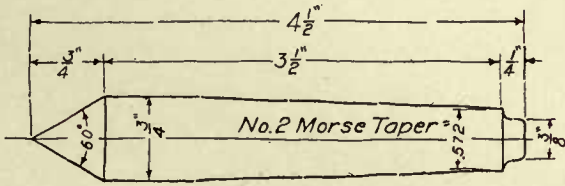
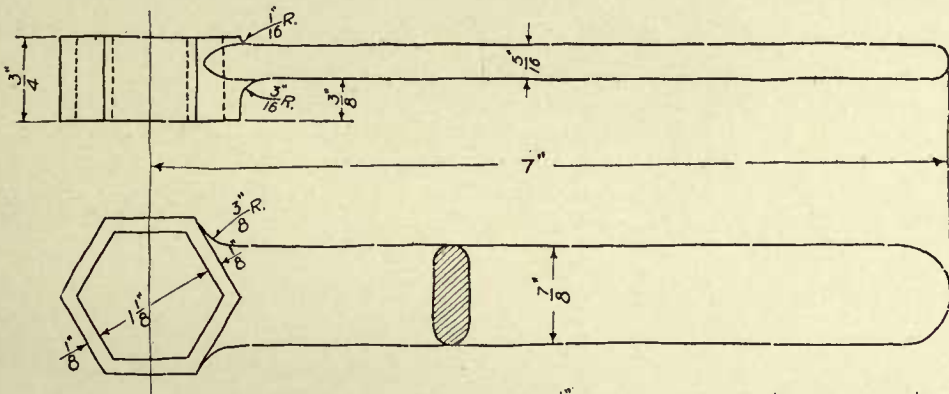
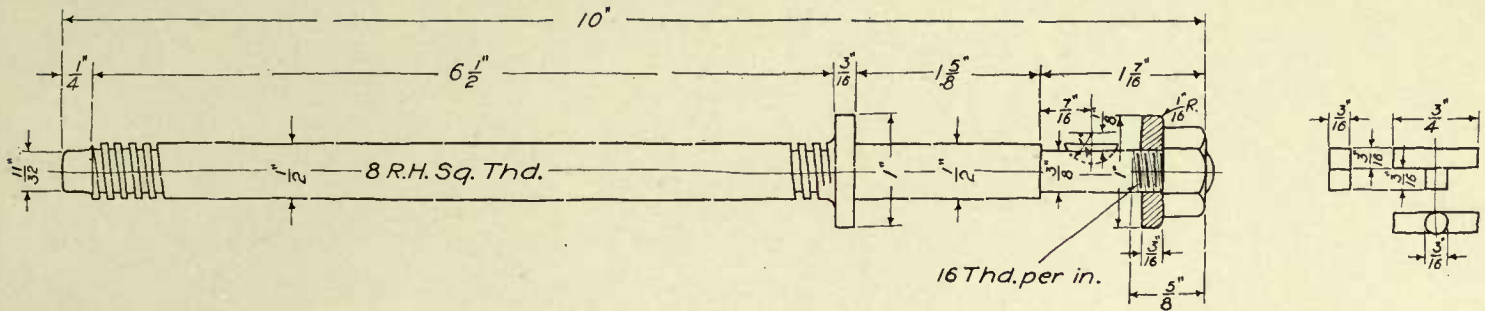

THE CARNEGIE TECHNICAL SCHOOLS
 PITTSBURGH, PA.
 SCHOOL OF APPRENTICES AND JOURNEYMEN
 MECHANICAL DRAWING

CLASS Industrial TRADE Machinist
 NAME John W. Roberts DATE Jan. 6. 08.

12" SPEED LATHE
 TAILSTOCK DETAILS
 SCALE Full Size DWG. No. C-1025

LESSON No. 31.

TAILSTOCK ASSEMBLY.—Drawing C-1026 shows the tailstock completely assembled, with all the details numbered to correspond with the numbers in the “Bill of Material.”

Where dimensions are not shown on certain parts, the student is expected to refer to the detail drawings for the necessary information.

The saw cut on the side of the tailstock barrel is for the purpose of

allowing this part to clamp tightly around the spindle when the binding screw is tightened down.

The oil hole shown in the bell should be drilled after it is in place in the barrel, as it should of necessity be on the upper side of the bell.

Make this drawing and tracing very carefully; do not overlook any dimensions or notes. Bear in mind that nothing is good enough but the best work you are able to do.



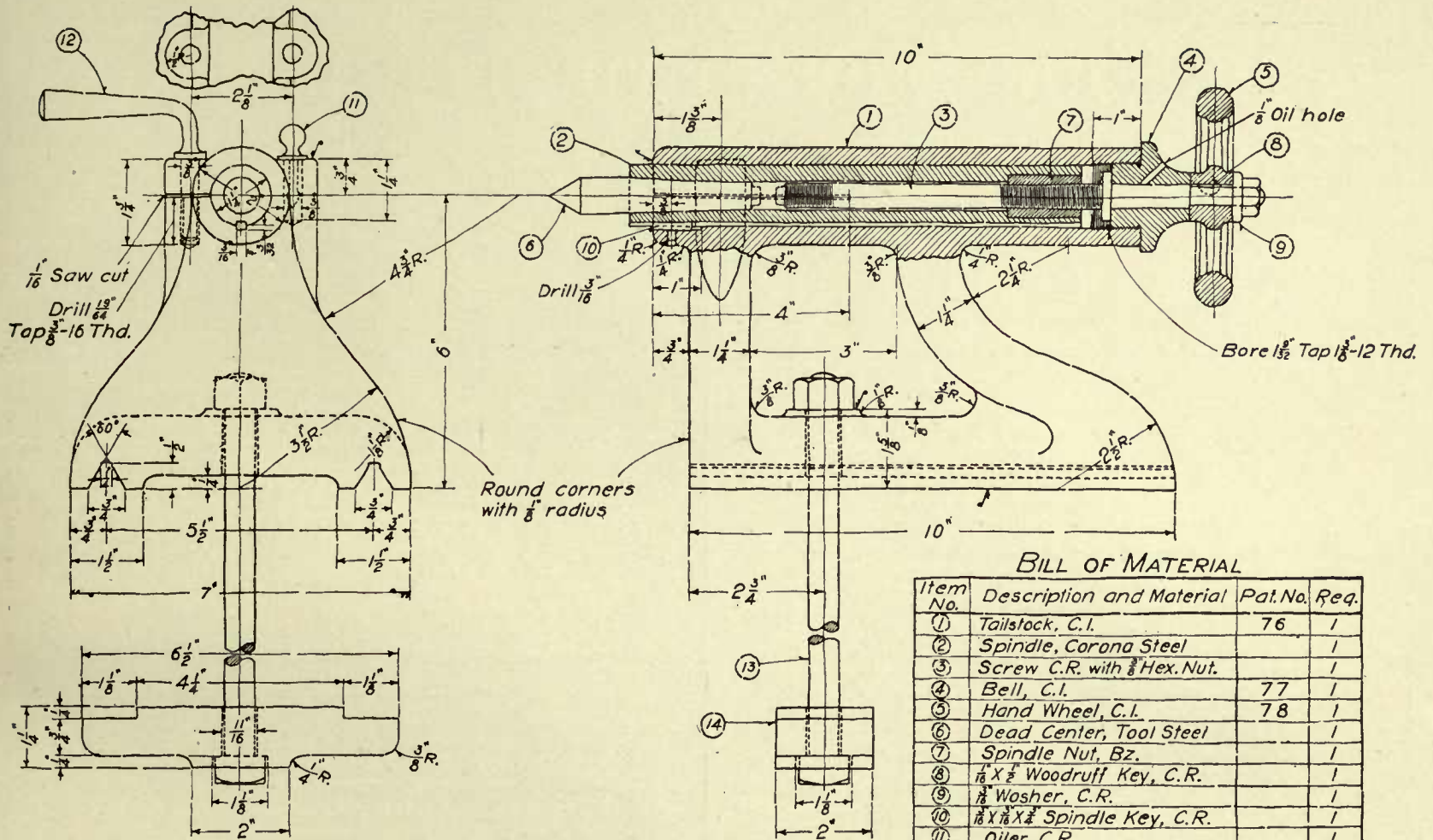

BILL OF MATERIAL

Item No.	Description and Material	Pat. No.	Req.
1	Tailstock, C.I.	76	1
2	Spindle, Corona Steel		1
3	Screw C.R. with 3/8 Hex. Nut.		1
4	Bell, C.I.	77	1
5	Hand Wheel, C.I.	78	1
6	Dead Center, Tool Steel		1
7	Spindle Nut, Bz.		1
8	1/8 X 3/8 Woodruff Key, C.R.		1
9	3/8 Washer, C.R.		1
10	1/8 X 3/8 X 3/8 Spindle Key, C.R.		1
11	Oiler, C.R.		1
12	Binding Screw, C.R.		1
13	3/8 X 8 Clamp Bolt with Hex. Nut		1
14	Clamp, W.I.		1

Note: For details see Dwg. C-1024 & C-1025

THE CARNEGIE TECHNICAL SCHOOLS

PITTSBURGH, PA.

SCHOOL OF APPRENTICES AND JOURNEYMEN

MECHANICAL DRAWING

CLASS Industrial

TRADE Machinist

NAME John W. Roberts

DATE Jan. 12-08.

12^{SP} SPEED LATHE
TAILSTOCK ASSEMBLY

SCALE 1/2 Size

DWG. No. C-1026

BOOKS FOR DRAUGHTSMEN.

FOR SALE BY

D. VAN NOSTRAND COMPANY, Publishers,

23 Murray and 27 Warren Streets, New York.

- | | | | |
|--|-------|---|--|
| Andre, Geo. G. —The Draughtsman's Hand Book of Plan and Map Drawing; including Instructions for the preparation of Engineering, Architectural and Mechanical Drawings. 8vo, cloth..... | 3.75 | | |
| Barber, T. W. —The Engineers' Sketch Book of Mechanical Movements, Devices, Appliances, Contrivances, Details employed in the Design and Construction of Machinery for every purpose. Nearly 2,000 illustrations. 8vo, cloth..... | 4.00 | | |
| Cathcart, W. L. —Machine Design. Part I, Fastenings. 8vo, cloth, illustrated..... | 3.00 | | |
| Cryer, T. and Jordan, H. G. —Machine Construction and Mechanical Drawing; including Spur and Bevel Gearing. For the Use of Students in Science and Technical Schools. Quarto, cloth..... | 1.20 | | |
| Davidson, F. A. —Drawing for Machinists and Engineers. Comprising a complete course of Drawing adapted to the requirements of Millwrights and Engineers; also, course of practical instruction in the coloring of Mechanical Drawings. 4th edition, 16mo..... | 1.50 | | |
| Donaldson, Jas. —Drawing and Rough Sketching for Marine Engineers, with Proportions, Instructions, Explanations and Examples, intended for the use of Seagoing Engineers and others in preparing Working Sketches and Rough Drawings; also, how to Design Engines, Boilers, Propellers, Paddle Wheels, Shafts, Rods, Valves, etc. 4th edition. Illustrated. Cloth..... | 2.40 | | |
| Draughtsman, The Building and Machine. —A practical guide to the projection and delineation of subjects met with in the practice of the Engineer, Machinist and Building Constructor, etc. 12mo, cloth..... | 2.00 | | |
| Engineers' and Machinists' Drawing Book. —A complete course of Instruction for the Practical Engineer. Illustrated by numerous engravings, 4to, half mor..... | 10.00 | | |
| Fox, Wm. and Chas. W. Thomas. —A Practical Course in Mechanical Drawing. Being a course of progressive lessons illustrated with many diagrams and figures. Especially adapted to use of schools, colleges, etc. Second edition revised. 12mo, cloth..... | 1.25 | | |
| | | The object of this work is to provide a simple, practical course of progressive lessons in Mechanical Drawing. All instructions are given in connection with a special concrete exercise, instead of being presented in an abstract and general manner. | |
| Heather, J. F. —Mathematical Instruments; their Construction, Adjustment, Testing, and Use, Comprising Drawing, Measuring, Optical, Surveying, and Astronomical Instruments. Enlarged edition, for the most part re-written. With numerous diagrams and figures. 12mo, cloth..... | 1.80 | | |
| Minifie, Wm. —Mechanical Drawing. A Text-Book of Geometrical Drawing, for the use of Mechanics and Schools, in which the Definitions and Rules of Geometry are familiarly explained; the Practical Problems are arranged from the most simple to the more complex, and in their descriptions technicalities are avoided as much as possible. With illustrations for Drawing Plans, Sections and Elevations of Buildings and Machinery; an Introduction to Isometrical Drawing, and an Essay on Linear Perspective and Shadows. Illustrated by over 200 diagrams, engraved on steel. With an Appendix on the Theory and Application of Colors. 8vo, cloth, 9th thousand..... | 4.00 | | |
| Rautenstranch, W., and Williams, J. T. —Machine Drafting and Empirical Design. A Text-book for Students in Engineering Schools. Part I on Machine Drafting. 8vo, cloth, 70 pp..... | 1.25 | | |
| Reinhardt, C. W. —Lettering for Draftsmen, Engineers, and Students. A Practical System of Freehand Lettering for Working Drawings. Revised and Enlarged. Twenty-sixth Thousand. Oblong Boards..... | 1.00 | | |
| Ripper, William. —A course of Instruction in Machine Drawing and Design for Technical Schools and Engineer Students. With 52 plates and numerous explanatory engravings. Folio, cloth..... | 6.00 | | |
| Rose, Joshua. —Mechanical Drawing Self-Taught. Comprising Instructions in the Selection and Preparation of Drawing Instruments, Elementary Instruction in Practical Mechanical Drawing, together with Examples in Simple Geometry and Elementary Mechanism, including Screw Threads, Gear Wheels, Mechanical Motions, Engines and Boilers. Illustrated. 8vo, cloth..... | 4.00 | | |



UNIVERSITY OF CALIFORNIA LIBRARY,
BERKELEY

**THIS BOOK IS DUE ON THE LAST DATE
STAMPED BELOW**

Books not returned on time are subject to a fine of 50c per volume after the third day overdue, increasing to \$1.00 per volume after the sixth day. Books not in demand may be renewed if application is made before expiration of loan period.

SEP 3 1927

SEP 17 1927

OCT 6 1927

DEC 12 1927

pre ml

YE 11097

Leeds
192820
T353
L4

