



Calhoun: The NPS Institutional Archive
DSpace Repository

Theses and Dissertations

1. Thesis and Dissertation Collection, all items

1994-03

The implementation of Electronic Data Interchange (EDI) with Defense transportation operations

Meier, John G.

Monterey, California. Naval Postgraduate School

<http://hdl.handle.net/10945/42946>

Downloaded from NPS Archive: Calhoun



Calhoun is a project of the Dudley Knox Library at NPS, furthering the precepts and goals of open government and government transparency. All information contained herein has been approved for release by the NPS Public Affairs Officer.

Dudley Knox Library / Naval Postgraduate School
411 Dyer Road / 1 University Circle
Monterey, California USA 93943

<http://www.nps.edu/library>

AD-A280 568



①

NAVAL POSTGRADUATE SCHOOL Monterey, California



THESIS

DTIC QUALITY INSPECTED 2

S DTIC
ELECTE
JUN 21 1994
G D

**THE IMPLEMENTATION OF
ELECTRONIC DATA INTERCHANGE (EDI)
WITH DEFENSE TRANSPORTATION
OPERATIONS**

by

John G. Meier III

March, 1994

Principal Advisor:
Associate Advisor:

Dan C. Boger
David G. Brown

Approved for public release; distribution is unlimited.

94 6 20 038

94-18971



REPORT DOCUMENTATION PAGE

Form Approved OMB No. 0704

Public reporting burden for this collection of information is estimated to average 1 hour per response, including the time for reviewing instruction, searching existing data sources, gathering and maintaining the data needed, and completing and reviewing the collection of information. Send comments regarding this burden estimate or any other aspect of this collection of information, including suggestions for reducing this burden, to Washington Headquarters Services, Directorate for Information Operations and Reports, 1215 Jefferson Davis Highway, Suite 1204, Arlington, VA 22202-4302, and to the Office of Management and Budget, Paperwork Reduction Project (0704-0188) Washington DC 20503

1. AGENCY USE ONLY (Leave blank)	2. REPORT DATE March 1994	3. REPORT TYPE AND DATES COVERED Master's Thesis	
4. TITLE AND SUBTITLE THE IMPLEMENTATION OF ELECTRONIC DATA INTERCHANGE (EDI) WITH DEFENSE TRANSPORTATION OPERATIONS		5. FUNDING NUMBERS	
6. AUTHOR(S) Meier, John G. III		8. PERFORMING ORGANIZATION REPORT NUMBER	
7. PERFORMING ORGANIZATION NAME(S) AND ADDRESS(ES) Naval Postgraduate School Monterey CA 93943-5000		10. SPONSORING/MONITORING AGENCY REPORT NUMBER	
9. SPONSORING/MONITORING AGENCY NAME(S) AND ADDRESS(ES)		11. SUPPLEMENTARY NOTES The views expressed in this thesis are those of the author and do not reflect the official policy or position of the Department of Defense or the U.S. Government.	
12a. DISTRIBUTION/AVAILABILITY STATEMENT Approved for public release; distribution is unlimited.		12b. DISTRIBUTION CODE A	
13. ABSTRACT (maximum 200 words) Organizations have traditionally relied on paper to conduct business transactions. Although proven to be an effective and convenient medium for this purpose, paper may no longer be the most efficient. Advances in computers, communication, and electronic technology have provided alternatives to this traditional way of conducting business transactions. One such concept is Electronic Data Interchange (EDI), which allows information to be processed faster, more accurately, and at a lower cost than similar manual, paper-based, processing systems. This thesis examines the application of EDI to Defense transportation operations and includes a discussion of data format standards, hardware, software, and communications requirements. The Defense transportation EDI operating concepts involve the linking of carriers, MTMC, defense shipping activities, and DoD finance centers, which allows the electronic exchange of business data such as Government bills of lading, freight rate tenders, and carrier payment information. EDI involves more than simply automating existing business documents and processes; when properly implemented, EDI is a catalyst for streamlining inefficient, redundant, and outdated business practices.			
14. SUBJECT TERMS EDI; electronic data interchange; electronic commerce; electronic invoicing; transaction sets; ANSI ASC X12 message standards; transportation.			15. NUMBER OF PAGES 158
			16. PRICE CODE
17. SECURITY CLASSIFICATION OF REPORT Unclassified	18. SECURITY CLASSIFICATION OF THIS PAGE Unclassified	19. SECURITY CLASSIFICATION OF ABSTRACT Unclassified	20. LIMITATION OF ABSTRACT UL

Approved for public release; distribution is unlimited.

The Implementation of
Electronic Data Interchange (EDI)
With Defense Transportation Operations

by

John G. Meier III
Lieutenant, Supply Corps, United States Navy
B.S., Michigan Technological University, 1986

Submitted in partial fulfillment
of the requirements for the degree of

MASTER OF SCIENCE IN MANAGEMENT

from the

NAVAL POSTGRADUATE SCHOOL
March 1994

Author:



John G. Meier III

Approved by:

Dan C. Boger, Principal Advisor

David G. Brown, Associate Advisor

David R. Wipple, Chairman
Department of Systems Management

Accession For	
NTIS CRA&I	<input checked="" type="checkbox"/>
DTIC TAB	<input type="checkbox"/>
Unannounced	<input type="checkbox"/>
Justification	
	
Availability Codes	
Dist	Avail and/or Special
A-1	

ABSTRACT

Organizations have traditionally relied on paper to conduct business transactions. Although proven to be an effective and convenient medium for this purpose, paper may no longer be the most efficient. Advances in computers, communication, and electronic technology have provided alternatives to this traditional way of conducting business transactions. One such concept is Electronic Data Interchange (EDI), which allows information to be processed faster, more accurately, and at a lower cost than similar manual, paper-based, processing systems. This thesis examines the application of EDI to Defense transportation operations and includes a discussion of data format standards, hardware, software, and communications requirements. The Defense transportation EDI operating concepts involve the linking of carriers, MTMC, defense shipping activities, and DoD finance centers, which allows the electronic exchange of business data such as Government bills of lading, freight rate tenders, and carrier payment information. EDI involves more than simply automating existing business documents and processes; when properly implemented, EDI is a catalyst for streamlining inefficient, redundant, and outdated business practices.

TABLE OF CONTENTS

I.	INTRODUCTION	1
A.	BACKGROUND	1
B.	OBJECTIVES	3
C.	RESEARCH QUESTIONS	3
D.	SCOPE	4
E.	METHODOLOGY	4
F.	DEFINITIONS AND ABBREVIATIONS	5
G.	ORGANIZATION OF STUDY	5
II.	ELECTRONIC DATA INTERCHANGE OVERVIEW	7
A.	ELECTRONIC DATA INTERCHANGE DEFINITION	8
B.	PURPOSE OF ELECTRONIC DATA INTERCHANGE	9
C.	BACKGROUND OF ELECTRONIC DATA INTERCHANGE	11
	1. The Historical Emergence of Standards	11
	2. American National Standards Institute and the Accredited Standards Committee X12	13
	a. ASC X12 Organization	13
	(1) ASC X12 Overview Committees.	14
	(2) ASC X12 Subcommittees and Task Groups.	14
	(3) Data Interchange Standards Association, Inc (DISA).	16

b.	ASC X12 Standards Approval	16
D.	BENEFITS OF ELECTRONIC DATA INTERCHANGE	19
1.	Savings	20
2.	Accuracy	20
3.	Speed	20
E.	EMERGING ISSUES	21
1.	Auditing	21
2.	Legal	22
a.	Trading Partner Agreements	23
b.	Electronic Signatures	24
3.	Security	25
a.	Encryption	26
b.	Authentication	27
III.	ELECTRONIC DATA INTERCHANGE DATA FORMAT STANDARDS	28
A.	INTRODUCTION	28
B.	TYPES OF DATA FORMAT STANDARDS	29
C.	ANSI ASC X12 Standard	30
1.	Transaction Set Standards	30
a.	Transaction Set Tables	32
b.	Data Segments	35
c.	Data Elements	37
2.	ASC X12 Foundation Standards	40
a.	X12.22 Data Segment Directory and X12.3 Data Element Dictionary	41
b.	X12.5 Interchange Control Structures	41

(1) Transaction Set Envelope.	43
(2) Functional Group Envelope.	43
(3) Interchange Control Envelope.	44
c. X12.6 Application Control Structures	45
D. IMPLEMENTATION CONVENTIONS	45
IV. ELECTRONIC DATA INTERCHANGE ARCHITECTURE	47
A. ELECTRONIC DATA INTERCHANGE FUNCTIONS	47
B. SYSTEM DESIGN	49
1. Hardware Requirements	49
2. Communications	51
a. Direct	53
b. Value Added Networks	54
C. SOFTWARE REQUIREMENTS	57
1. Primary Software Functional Areas	58
a. Data Mapping	58
b. Data Extraction (conversion)	59
c. Translation	60
d. Communications	61
2. Additional Software Functions	61
a. Bridging Software	61
b. Security Software	62
V. DEPARTMENT OF DEFENSE IMPLEMENTATION OF ELECTRONIC DATA INTERCHANGE	65
A. ELECTRONIC COMMERCE	65

B.	ELECTRONIC COMMERCE THROUGH EDI	66
1.	Policy Milestones	66
	a. DEPSECDEF Memo	67
	b. DMRD 941	68
2.	Organization	68
3.	Proposed Savings and Benefits	69
	a. Direct Cost Savings	73
	b. Indirect Cost Savings	77
	c. Total Direct and Indirect Cost Savings .	78

VI. DEFENSE TRANSPORTATION ELECTRONIC DATA INTERCHANGE

	IMPLEMENTATION	80
A.	DEFENSE TRANSPORTATION OVERVIEW	80
	1. United States Transportation Command	80
	2. Air Mobility Command	81
	3. Military Traffic Management Command	82
	4. Military Sealift Command	82
B.	SYSTEMS APPROACH: TRANSACTION SETS AND APPLICATION PROCESSES	83
	1. Transaction Sets	84
	2. Application Processes	86
	a. Tender Submittal/Acceptance	87
	b. Shipment Information	89
	c. Prepayment Auditing and Payment	90
	d. Postpayment Auditing	91
C.	DEFENSE TRANSPORTATION EDI OPERATING CONCEPT .	91

1. Defense Transportation EDI Operating Concept:	
Freight	92
a. CONUS Freight Management System	93
b. Freight Operating Concept Data Flows	95
2. Defense Transportation EDI Operating Concept:	
Personal Property	96
a. Transportation Operational Personal Property Standard System	97
b. Worldwide Household Goods Information System for Transportation	98
c. Personal Property Operating Concept Data Flows	98
3. Future/Proposed Enhancements	101
a. Defense Transportation Payment System (DTRS)	101
b. Electronic Funds Transfer	104
c. Transaction Set 820, Payment Order/Remittance Advice	105
d. Electronic Submission of Guaranteed Traffic Tenders	105
D. ADDITIONAL DEFENSE TRANSPORTATION ELECTRONIC DATA	
INTERCHANGE INITIATIVES	107
1. Cargo Movement Operations System	107
2. Advanced Arrival Notification Interface	108
3. Worldwide Port System	108
4. Transportation Discrepancy Report	108

5. Transportation Management System	109
6. Transportation Operation Management	109
7. Do-It-Yourself EDI Automated Loading System	110
8. Household Goods EDI Audit Transactions	110
9. Defense Transportation Tracking System	111
E. ASSOCIATED DEFENSE TRANSPORTATION ELECTRONIC DATA	
INTERCHANGE ISSUES	111
1. Telecommunications Architecture	111
2. Barriers to Defense Transportation Electronic	
Data Interchange Implementation	113
a. Lack of Knowledge and/or Understanding	114
b. Decentralization of Effort	114
c. Cost-benefit Analysis and Resourcing	115
d. Standardization	116
F. CHAPTER SUMMARY	116
VII. SUMMARY AND CONCLUSIONS	118
A. SUMMARY	118
B. CONCLUSIONS	123
C. RESEARCH QUESTIONS	125
APPENDIX A	129
APPENDIX B	132
LIST OF REFERENCES	139

BIBLIOGRAPHY 144

INITIAL DISTRIBUTION LIST 146

I. INTRODUCTION

A. BACKGROUND

Electronic Data Interchange (EDI) is rapidly emerging as the preferred method for conducting transactions involving the exchange of "business information." As one industry analyst predicted: [Ref. 1:p. 45]

By the end of this decade, EDI no longer will be a competitive tool that differentiates one company from another. It will be a business necessity for survival.

Public and private organizations, including civilian as well as military components, have traditionally relied on paper to conduct business transactions. Although paper has proven to be an effective and convenient medium for this purpose, for many situations it may no longer be the most efficient. Advances in computer, communication, and electronic technology have provided alternatives to the "traditional" ways of conducting business. Recent examples of technological advancements which have produced changes in the manner in which information is handled include:

- Cellular and mobile telephones
- Photocopying machines
- Personal computers
- Facsimile machines

Each of these applications has taken an existing process, or way of doing things, and "made it easier" and more efficient.

Today, especially with both the public and private sectors experiencing diminishing budgetary resources, organizations are continuing their search for ways to "do more with less." One concept that has demonstrated considerable promise is that of *Electronic Data Interchange* (EDI).

The use of EDI technology is becoming more common in many organizations and promises to become the preferred method for exchanging information in the future. Through the use of electronic information processing techniques, EDI enables information to be processed faster, more accurately, and at a lower cost than with similar manual, paper-based, processing systems.

When discussing the application of electronic data interchange, it is important to understand that EDI is a technology, a way of doing business, and not a specific system. The implementation of EDI involves more than just the automation of existing processes. Electronic data interchange provides the opportunity to revise existing information handling methods which can result in improved performance, economies, and efficiencies in operations.

Recognizing the potential of EDI, the Deputy Secretary of Defense, in May of 1988, issued a memorandum that EDI was to "become the way of doing business" for the Department of

Defense (DoD). In November 1990 the Deputy Secretary of Defense approved Defense Management Report Decision (DMRD) 941, which directed the development, implementation, and management of a standard DoD EDI system.

The strategic goal of DoD's current EDI efforts is to provide the capability to initiate, conduct, and maintain the external and internal business-related activities utilizing electronic media.

B. OBJECTIVES

The primary objective of this thesis is to examine the application of electronic data interchange to Department of Defense transportation operations.

A secondary objective is to provide an explanation of EDI fundamentals including:

- What EDI is.
- What the components of EDI are.
- EDI system configurations.

C. RESEARCH QUESTIONS

To achieve the primary objective of the research, the following research question is posed:

What actions have been taken to implement electronic data interchange with Department of Defense transportation operations?

To answer the basic research question, the following subsidiary questions are addressed:

- What are the essential elements of EDI?
- What has been the Department of Defense's approach to the implementation of EDI technology?
- What benefits may be realized from DoD's EDI implementation with defense transportation operations?
- What are the specific areas in which EDI has been applied to DoD transportation?
- What are the proposed defense transportation EDI application areas?
- What, if any, barriers exist to the optimal implementation of EDI?

D. SCOPE

The scope of this thesis focuses on the following primary areas:

- Providing an overview of EDI, to include a discussion of the necessary elements.
- Discussion of DoD EDI implementation.
- An examination of EDI application to DoD transportation operations.

Throughout this thesis, it is assumed that the reader has some familiarity with defense transportation activities and operations. Additionally, this thesis is structured to provide those not familiar with electronic data interchange a basic understanding of its concept and operation.

E. METHODOLOGY

The methodology used to complete this thesis consisted of literature reviews as well as research involving interviews

with appropriate Department of Defense, Defense Logistics Agency, General Services Administration, Army, Air Force, Navy, Marine Corps, and Logistic Management Institute¹ representatives. This enabled the author to determine where the Department of Defense objectives are focused and to what extent they have been instituted and implemented.

F. DEFINITIONS AND ABBREVIATIONS

A list of acronyms used within this thesis is presented in Appendix A. Working definitions of terms and concepts used in this thesis will be provided within the text of the thesis as deemed necessary.

G. ORGANIZATION OF STUDY

This thesis is organized to provide the reader with an overview of EDI and its application to defense transportation operations. Chapter II provides the reader with an overview of electronic data interchange, including: what it is, its purpose, historical background, potential benefits, and emerging issues.

Chapter III discusses EDI data format standards and their importance to EDI communications. This chapter also discusses implementation conventions, which are guidelines for the standardized use of the data format standards.

¹ The Logistics Management Institute is a federally funded research and development center that performs specific studies for DoD.

Chapter IV contains a discussion of the architecture of EDI application and covers required hardware, software and communication connections.

Chapter V discusses the overall Department of Defense approach to EDI implementation and introduces significant policy milestones which have encouraged EDI's acceptance within DoD.

Chapter VI contains the examination of DoD's application of EDI to defense transportation activities.

Chapter VII provides the reader with a summary and presents the author's conclusions.

II. ELECTRONIC DATA INTERCHANGE OVERVIEW

Properly planned and implemented EDI has the potential to restructure markets, re-engineer inefficient manual processes, open up access to new customers, streamline flow of materials throughout an entire value chain, enhance quality across the board, and save millions of dollars. (Thomas P. Colberg, Price Waterhouse)

Communication and information are vital components of most of the activities in which organizations engage. In many cases they are the primary determinants in decision making, with information consisting of the facts, figures, and knowledge, while communication is the means of conveying this information from those who possess it to those who require it. Recognizing the importance of communication and information, organizations are continually looking for ways to improve the efficiency and effectiveness of their communication and information handling processes. The past few decades have produced an astonishing array of advances in the methods by which information is handled:

- Photocopying machines
- Cellular and mobile telephones
- Facsimile machines
- Personal computers
- Electronic mail (E-mail)
- Electronic data interchange
- Teleconferences

- Overnight document delivery services

With this ever increasing assortment of communication and information processing techniques, it is important to establish what electronic data interchange (EDI) is. To understand the true potential and significance of EDI it must be remembered that EDI is a technology, an approach to doing things, rather than a specific system.

A. ELECTRONIC DATA INTERCHANGE DEFINITION

Electronic Data Interchange is the inter-organizational, computer-to-computer exchange of business documentation and information in a standardized, machine-processable format.

[Ref. 2:p. 4]

This definition of EDI contains a number of key points which distinguish it from other forms of paper or electronic communication: [Ref. 2:pp. 4-5]

- **Inter-organizational:** While EDI technology is equally applicable to exchanging information within organizations, by definition EDI is organization-to-organization.
- **Computer-to-computer:** Once the data is entered into the originator's application, the information flows directly to the receiver's application. The key point is that once entered, the data flows between organizations without human intervention and without paper.
- **Business Documentation:** Information that is currently found on any business form is appropriate for EDI. Examples of typical business documents which are exchanged electronically include: purchase orders, invoices, bills of lading, status reports, receipt acknowledgements, and payment information.

- **Standardized, Machine-processable Format:** As discussed, EDI is the electronic exchange of information from one computer to another without human intervention. For this to occur the data must be precisely formatted to allow computers to both read and understand the information.

B. PURPOSE OF ELECTRONIC DATA INTERCHANGE

The primary purpose of EDI is to provide the opportunity to make business processes more efficient by enhancing information management through the replacement of paper with electronic equivalents. This is accomplished through the use of established "standards" which provide the required structured format (language), allowing direct data transmission from one organization's computer to another organization's computer without human intervention. The basic functioning of EDI, compared to a "traditional paper-based" system, is shown in Figure 1 and Figure 2.

As shown in Figure 1, the originating organization creates a "document" when data is initially entered into its computer system. For the receiving organization to obtain and use this information the "document" will be printed, physically transferred (in this example by mail), and finally the data must be manually entered into their computer system. In contrast, Figure 2 illustrates the direct transmission of data computer-to-computer, requiring human intervention only for the initial data entry.

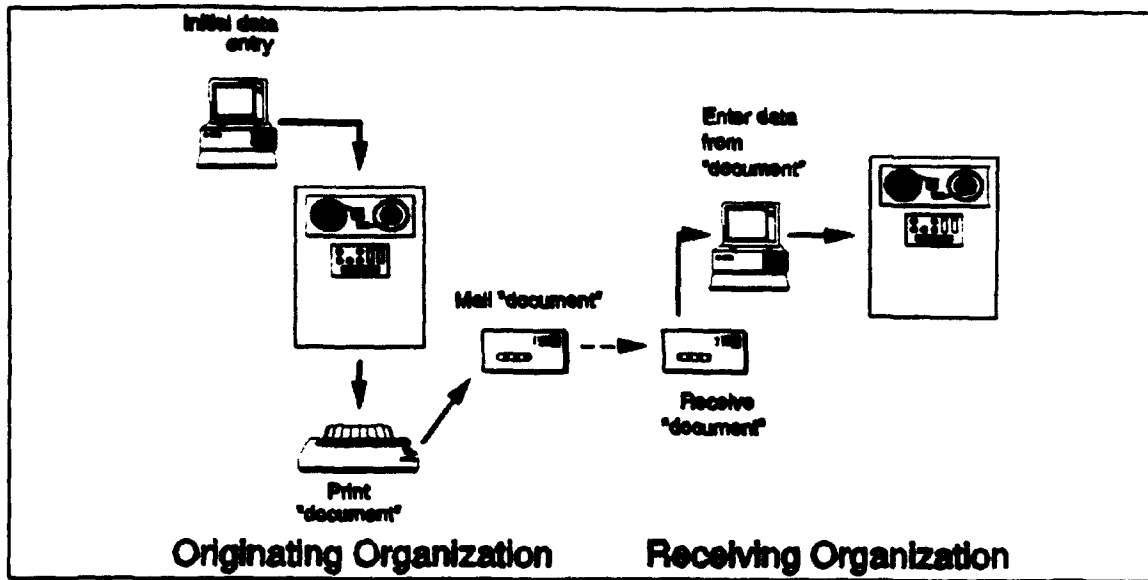

Figure 1. Example of a traditional paper-based method of exchanging information

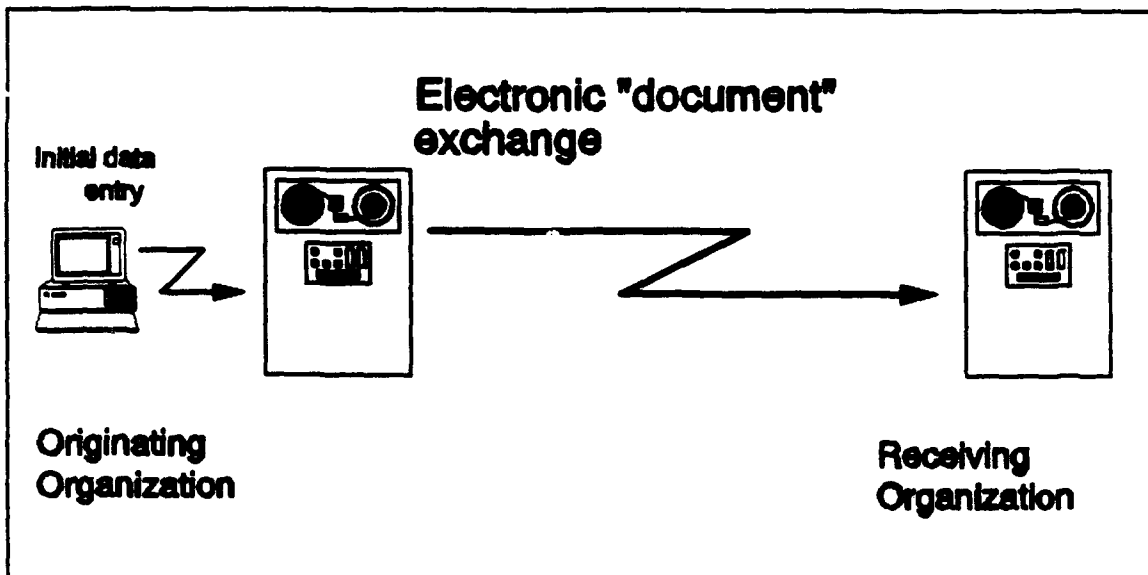

Figure 2. Example of an EDI-based information exchange

C. BACKGROUND OF ELECTRONIC DATA INTERCHANGE

1. The Historical Emergence of Standards

Computer-to-computer exchange of information is not new to American industry or to the Department of Defense (DoD). Since the 1960s, private companies and DoD activities have been exchanging business information electronically. A major characteristic, and drawback, of these early data exchange arrangements was the use of many different non-standard and proprietary data formats.

Prior to the development of standard data formats, organizations may have needed different computer systems or applications for each customer, or trading partner, with which it wished to electronically communicate. This in turn hindered the widespread acceptance of EDI, with organizations finding it cumbersome, time-consuming, and often expensive to expand their electronic communications to new trading partners.

The development of standard data formats played an important role in the development of EDI technology. Standardization eased the exchange of data and encouraged the use of EDI technology by eliminating the need to create special software for each trading partner's unique data format.

Standard data formats allow one software package to be used to generate transactions in a format allowing for the

exchange of information between multiple trading partners. By reducing the software requirements for exchanging information, standards help reduce the cost of new technology implementation, increasing the benefits to users by providing a common language between trading partners which may be in different industries. [Ref. 3:pp. 3-4]

Early standards development occurred in the transportation industry in the mid 1970's, when the Transportation Data Coordinating Committee (TDCC) developed industry-specific standards for ocean, motor, air, and rail carriers [Ref. 4:p. 6]. When this effort proved successful, other industries sought the help of TDCC in developing standards for their industries². As the number of industry-specific standards grew, recognition of the need for generic, cross-industry standards emerged [Ref. 5:p. 2].

In 1979, in response to the growing concern over the development of cross-industry standards, the American National Standards Institute (ANSI) chartered the Accredited Standards Committee X12 (ASC X12) to develop uniform standards to facilitate the electronic interchange of business transactions between and among industries [Ref. 4:p. 1]. The ASC X12 standard is the only set of standards approved by the American National Standards committee and are quickly becoming the only

² Examples of some of the industry-groups seeking the help of TDCC include: the grocery, chemical, and warehousing industries [Ref. 5:p. 2].

universally recognized standards for the electronic transmission of business data [Ref. 3:p. 60].

2. American National Standards Institute and the Accredited Standards Committee X12

Founded in 1918, The American National Standards Institute (ANSI) is a private organization which has been a significant contributor to the development of EDI, serving as a clearinghouse and information center for American National Standards as well as international standards. ANSI is recognized as the central body responsible for the identification and coordination of the development of a single, consistent set of voluntary standards called American National Standards. ANSI provides a democratic, consensus-based forum for all concerned to identify standards requirements, to plan to meet those requirements, and to agree on standards. ANSI does not develop standards but is responsible for the approval of standards which have been developed by professional societies, trade associations, and other organizations. [Ref. 4:p. 1]

a. ASC X12 Organization

As mentioned previously, in 1979 ANSI chartered the Accredited Standards Committee (ASC) X12 in response to the growing concern over the development of cross-industry standards. As with ANSI, ASC X12 is a private organization with membership open to any individual, company, or

organization which has an interest in ASC X12 activities and standards development.

The primary objective of ASC X12 is to develop uniform standards to facilitate the electronic interchange of business transactions between, and among industries [Ref. 4:p. 1]. As stated in the ASC X12 charter:

The scope of X12 is to provide standardization to facilitate interbusiness/institutional electronic interchange of transactions relating to order placement and processing; shipment and receiving information; invoicing; payment; and cash application date. [Ref. 3:p. 51]

The ASC X12 organization is composed of two overview committees as well as a number of subcommittees and task groups. The ASC X12 organization is structured as shown in Figure 3. [Ref. 4:p. 2]

(1) *ASC X12 Overview Committees.* The two overview committees are the Steering Committee and the Procedures Review Board. These committees are responsible for the following: [Ref. 2:p. 63]

- Steering Committee performs administrative functions for ASC X12 and provides coordination among task groups and subcommittees.
- Procedures Review Board (PRB) reviews all project proposals submitted to the committee. The PRB also manages draft standards, standards maintenance, and compliance guidelines.

(2) *ASC X12 Subcommittees and Task Groups.* The actual work of ASC X12 is conducted primarily by the subcommittees and task groups, who are responsible for the

Figure 3. ANSI ASC X12 organization

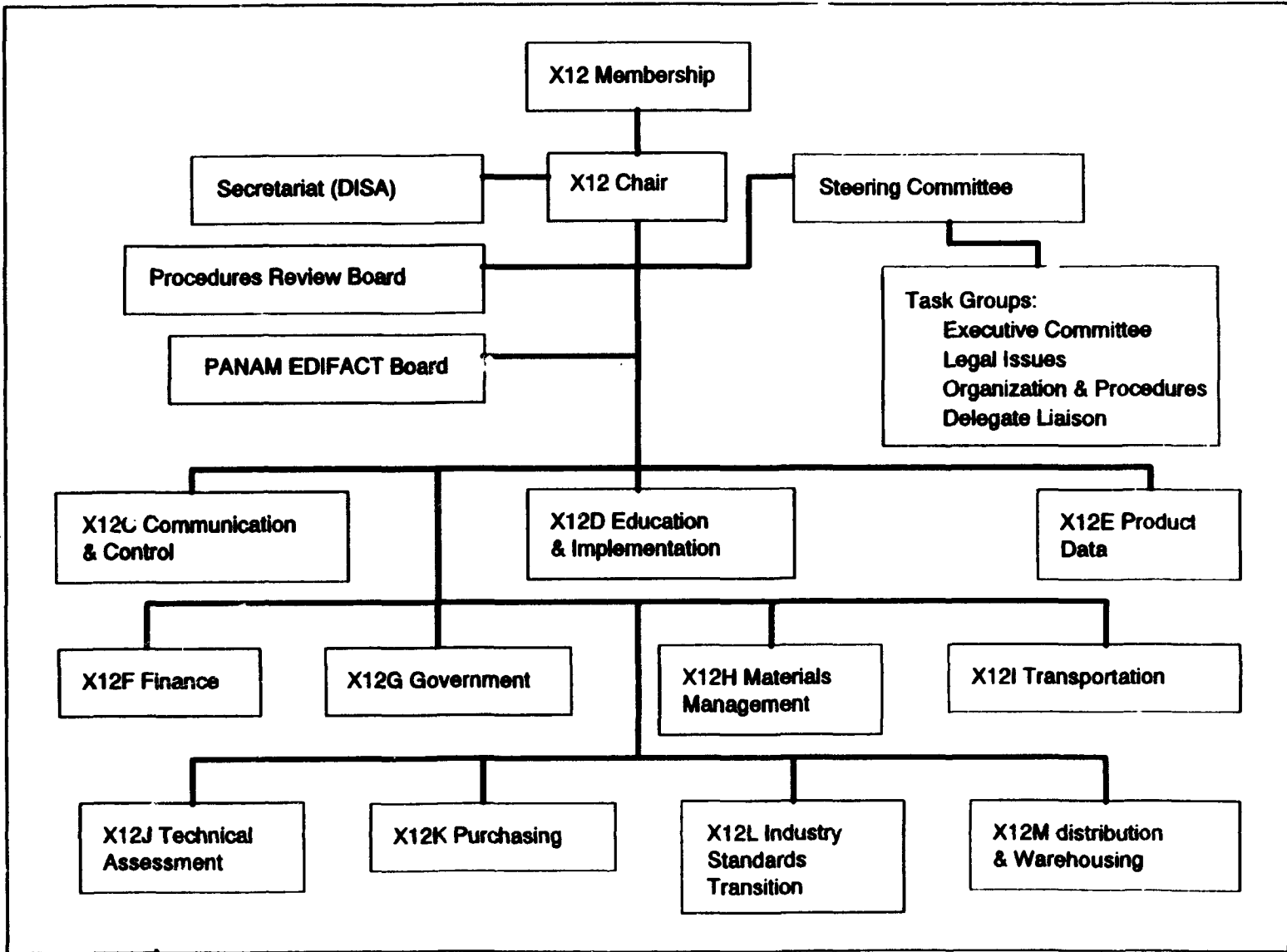

development of new, and the maintenance of existing, ASC X12 EDI standards. The subcommittees primarily focus on functional areas such as transportation, finance, purchasing, technical assessment, etc. Supporting the subcommittees and the Steering Committee are the task groups which focus on specific issues such as legal and organizational procedures. The recommendations of the subcommittees and task groups are presented to the ASC X12 membership for formal acceptance and ratification. [Ref. 6:pp. 1-2]

(3) *Data Interchange Standards Association, Inc (DISA)*. DISA is a not-for-profit corporation, formed in 1987, to serve as ASC X12 secretariat. DISA staff provides administrative support for ASC X12 including management of ASC X12 membership, balloting, standards development and maintenance, publications, and communications with ANSI on behalf of ASC X12. [Ref. 6:p. 1]

b. ASC X12 Standards Approval

Any individual or organization, whether a member of the ASC X12 committee or not, can request that a new standard be developed or that an existing standard be modified. Such a request is usually submitted to the secretariat (DISA) who forwards the request to the Technical Assessment Subcommittee (X12J), as depicted in Figure 4. [Ref. 4:p. 5]

The Technical Assessment Subcommittee is responsible for assessing whether or not the request for a new

Figure 4. ANSI ASC X12 Standards Approval Process

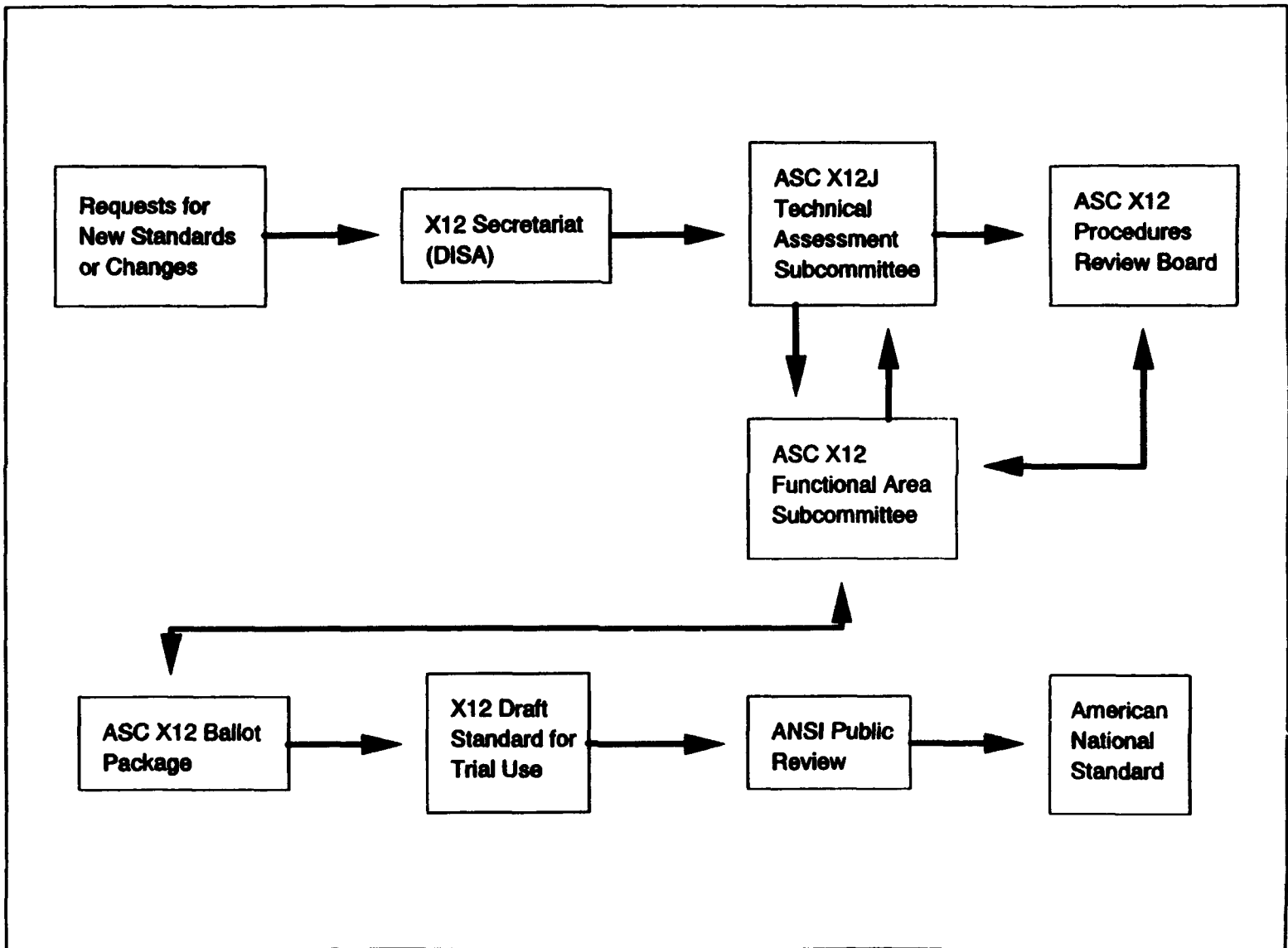

or modified standard is within the scope of ASC X12. If it is determined to be within scope, the Technical Assessment Subcommittee forwards the request to the applicable functional area subcommittee for review. Based on the request, the functional area subcommittee prepares a formal project proposal which is returned to the Technical Assessment Subcommittee for a consistency check with other standards. If the proposal is successful in passing this check, it is sent to the Procedure Review Board for an additional vote on whether the proposal is within the scope of ASC X12 and consistent with existing standards. If the proposal passes this vote it is referred back to the original functional area subcommittee for actual standards development. This subcommittee is then responsible for preparing the draft standard (proposed), which will in turn be subject to a technical assessment review as well as a Procedures Review Board check. Next, the proposed draft standard is distributed to all ASC X12 committee members for review, comment, and vote. After a review of the vote and comments, the proposed draft standard is sent to the Procedures Review Board for a vote on releasing the proposed draft standard. If the vote is in favor of release, the draft proposed standard is designated an ASC X12 draft standard, and is released for trial use. The ASC X12 draft is not yet a fully approved standard, still requiring ANSI approval. Once received by ANSI, the ASC X12 draft standard is again distributed for public review and

comment. It is only after the completion of this public process that the standard is approved and released by ANSI as an American National Standard (ANS)³. [Ref. 2:pp. 64-65]

D. BENEFITS OF ELECTRONIC DATA INTERCHANGE

Through the use of electronic, vice paper-based systems, EDI results in a more efficient and effective way to conduct business transactions. Primarily, the use of EDI decreases the transaction time associated with document/information handling while increasing the accuracy of the information exchanged. There are many possible and potential benefits from the implementation of EDI. Some of these are "more obvious" and easily quantifiable, while others are "less obvious" and more qualitative in nature. While the actual realized benefits will be situationally dependent, a majority of the benefits of EDI implementation will fall under one of the following categories:

- Savings
- Accuracy
- Speed

³ It is important to note that compliance with ANSI approved American National Standards is strictly voluntary. Though not having the force of law, the standards provided a common, accepted format for the electronic exchange of information.

1. Savings

EDI eliminates, or reduces, the volume of paperwork required to conduct many standard business transactions. With this paperwork reduction comes a corresponding reduction in mailing and postage costs, along with costs associated with the personnel and equipment required to manually process paper-based transactions.

2. Accuracy

Many non-EDI information processing systems are characterized by a data entry/re-entry cycle in which the same data is entered and re-entered numerous times. EDI eliminates this re-entering of data by exchanging data directly between computer systems. This direct exchange of data reduces the possibility of data errors which can result from repeated "handling" and human intervention.

3. Speed

With non-EDI information processing systems, the process of exchanging data is often slow, resulting from a reliance on mail, courier service, facsimile machines, or even telephone. EDI dramatically decreases the time spent exchanging data between users by the virtually instantaneous, computer-to-computer, transmission of information electronically.

The proper implementation of EDI results in the ability to conduct business faster, more accurately, and at a lower cost

than similar manual, paper-based information processing systems.

E. EMERGING ISSUES

The implementation of EDI brings with it its own set of concerns. As discussed, EDI involves the reduction, or elimination, of much of the paperwork involved in conducting business transactions. Consequently, the affected process moves from an environment which relies on tangible paper documents to one which could be characterized as relatively intangible, where the documents are composed of electronic bits and bytes. Although EDI has many advantages over paper-based systems care must be taken, as it must with paper documents, to ensure that EDI messages are authentic, properly authorized, and traceable. The messages also must be protected from loss, modification, or unauthorized disclosure during transmission as well as storage. These concerns can be grouped into the following three categories:

- Auditing
- Legal
- Security

1. Auditing

In an EDI system, as with any system used to process business transactions, the need exists for the ability to verify that the system is processing information correctly, as

well as processing the "correct" information. As in paper-based systems, verification is provided by the capability to track transactions from origination to closure. This tracking of the transaction through the system is referred to as the "audit trail". [Ref. 3:p. 47]

The key to EDI auditability is having adequate controls to insure proper transaction handling. The control mechanisms for an EDI system should address accuracy, completeness, security, auditability, timeliness and recoverability issues. Additionally, controls relating to the use of EDI networks and Electronic Funds Transfer (EFT) should be included where appropriate. [Ref. 2:p. 179]

The use of EDI, or any other automated system, from an auditing viewpoint has no effect on the need to follow generally accepted auditing standards and procedures. Although EDI may change the way in which organizations conduct business transactions, the use of EDI does not limit auditability. [Ref. 2:p. 179]

2. Legal

EDI is used to exchange data relating to many types of business transactions, many of which are intended to form legally binding contracts between parties. It is when EDI is used as the basis for forming a contract, or any legally binding agreement, that the majority of the legal issues emerge. These issues primarily concern items such as

enforceability, signature requirements, and terms and conditions, areas in which paper documents were inherently part of transaction. In response to these concerns, two primary areas emerge as requiring comment: [Ref. 2: pp. 169-173]

- Trading Partner Agreements (TPA)
- Electronic Signatures

a. Trading Partner Agreements

One way to deal with legal issues concerning the conduct of business through EDI is by the use of Trading Partner Agreements. Trading Partner Agreements (TPAs) are written, negotiated instruments of understanding which establish the rights and obligations, as well as create legally binding obligations between trading partners. When establishing TPA's, a separate document must be negotiated between each pair of trading partners and signed prior to initiating EDI transactions. [Ref. 2:p. 172]

Trading Partner Agreements accomplish two primary purposes: 1) they establish the contractual relationships and references between trading partners (terms of conducting business), and 2) they specify the EDI technical protocols that will be used in conducting business through EDI-based transactions. In establishing the foundation for conducting business through EDI, TPAs provide clarification of various

technical and telecommunications issues associated with EDI business information exchange such as: [Ref. 7:pp. 5-6 - 5-7]

- The applicable EDI implementation guidelines.
- Telecommunications mailbox addresses and routings for each trading partner.
- Schedules for transmitting messages.
- Procedures for resolving transaction and system errors.
- Back-up procedures in the event of system failure.
- The electronic recordkeeping responsibilities of each trading partner.
- The password generation and security methods that each trading partner will use.

By addressing these types of concerns upfront, TPAs help reduce future disputes concerning the "legality" and applicability of EDI transactions.

b. Electronic Signatures

Contracts are typically considered valid only when signed by the parties involved. Performing transactions electronically, EDI eliminates the physical document which in the past was "signed" by the trading partners. These signatures were important because they signified the intent to be bound by, and to comply with, the terms of the contract. An amendment to Title 41 of the Code of Federal Regulations, Part 101-41 (41 CFR 101-41) specifically addresses this concern and authorizes the use of electronic signatures in the

transportation industry provided they are authenticated. That regulation, in part, reads: [Ref. 8]

Electronic Data Interchange (EDI) means the electronic exchange of transportation information by means of electronic transmission of the information in lieu of the creation of a paper document....Signature, in the case of an EDI transmission, means a discreet authenticating code intended to bind parties to the terms and conditions of a contract.

3. Security

In June 1991 the National Institute of Standards and Technology published a Computer Systems Laboratory (CSL) Bulletin on computer systems technology, which provided explicit guidance on EDI security. Specifically, it directed that activities implementing EDI should attempt to satisfy the following security requirements: [Ref. 7:pp. 5-2 - 5-3]

- **Message Integrity:** The transmitting activity must ensure that all critical information transmitted is received unchanged.
- **Confidentiality:** Activities must restrict access to EDI transactions that contain personal, trade-secret, or sensitive data.
- **Originator Authentication:** The receiving activity must have assurance that the EDI message was transmitted by the indicated originator.
- **Nonrepudiation:** Those activities establishing EDI systems must ensure that binding proposals submitted by any of the trading partners cannot be denied.
- **Availability:** All activities must develop back-up procedures for the protection of important data in case of systems failure.

The security of electronic data is of significant importance for both users and auditors, who want assurances

that EDI data are protected against unauthorized disclosure or modification during transmission, processing, and storage. When analyzing the security requirements of an EDI system, it is important to remember that not all EDI data need to be secured. If the data were not given extra security when using paper transactions, they probably do not require extra security in an EDI environment. [Ref. 2:p. 180]

For those data identified as requiring extra security, cryptographic security may be used. Currently two types of cryptographic security are supported by the X12 standard and in use for EDI data: [Ref. 2:p. 180]

- Encryption
- Authentication

a. Encryption

Encryption involves the coding of a normal message into garbled form which cannot be read until it is decoded back to its original form. When using encryption, the originator of a message uses a special data encryption standard (DES) algorithm to transform readable text into unreadable coded text. The unreadable coded text is then transmitted to the receiving activity who must use the same DES algorithm to decode the message. Encryption protects the message from unauthorized disclosure since only those with the appropriate "key" can decipher the message. [Ref. 2:p. 180]

b. Authentication

Where encryption protects the secrecy of the data, authentication protects its integrity, making any modification of the data obvious to the receiver. With authentication, both the originating and receiving activities have encryption/decryption keys. A DES algorithm is applied to the EDI message and originator's key to produce a message authentication code (MAC) that is unique to that message-key combination. The MAC is appended to the message and transmitted, along with the key identifier, to the receiver. To authenticate the message, the receiver uses the DES algorithm to recompute the MAC using the original message and appropriate key. If the two MACs are identical, then the message has not been altered. Users must remember that when using authentication by itself, the original message is transmitted in plain text. [Ref. 7:p. 5-6]

The use of encryption and/or authentication, either alone or together, helps control unauthorized disclosure and modification of EDI data. In addition, controls may be required to restrict and/or prevent unauthorized physical access to EDI equipment. Both types of security must be addressed to ensure the optimal protection of an EDI system.

III. ELECTRONIC DATA INTERCHANGE DATA FORMAT STANDARDS

A. INTRODUCTION

As defined in Chapter II, electronic data interchange (EDI) is the inter-organizational, computer-to-computer exchange of business documentation and information in a standardized, machine-processable format. Fundamental to this definition is the reliance on, and use of, *standardized, machine-processable* data formats. The use of standard data formats, also referred to as "standards", is critical to the successful implementation and utilization of EDI, providing the key to making EDI practical. EDI standards facilitate the electronic exchange of data by providing a uniform method for configuring unstructured data into a structured format. This structuring and standardization of data format, allows computers to transfer, read, understand, and process information automatically, without additional human intervention.

When discussing EDI data format standards it is important to remember that:

- Compliance with the standards is strictly voluntary, decided among trading partners.
- The standards specify only the format, rules, and data content of electronic business transactions, they do not address how trading partners will establish the required physical communications link to exchange EDI data.

B. TYPES OF DATA FORMAT STANDARDS

Standards were developed to ease communication between organizations, with several different standards emerging. These different standards can be classified as being: [Ref. 9:p. 22]

- Proprietary. Proprietary data standards are those established by individual organizations for communicating with trading partners within a "closed" system. For example, Roadway Express, Inc. has its "E-Z BILL" shipment information management system which provides bill of lading, shipment status, and claims information to system users [Ref. 10].
- Industry-Specific. While proprietary data standards are established by individual organizations, industry-specific standards are set by an industry trade group, to promote intra-industry electronic communication. Examples of industry-specific standards include: 1) Transportation Data Coordinating Committee (TDCC) - Transportation industry, 2) Uniform Communication Standard (UCS) - Grocery industry, and 3) Warehouse Information Network Standards (WINS) - Warehouse industry.
- Cross-Industry. In the United States there is only one inter-industry EDI data format: the American National Standards Institute (ANSI) Accredited Standard Committee X12 (ASC X12) Standard.
- International. While ASC X12 is the standard for EDI in the United States, the standard for use in Europe and in many other parts of the world is the United Nations/EDI for Administration, Commerce, and Transport (EDIFACT). Worldwide, EDIFACT use is increasing and there is consideration for the future development of a universal standard resulting from an alignment between EDIFACT and ASC X12.

Due to their widespread use and applicability to EDI information exchanges in the United States, the discussion of the structure of standards will specifically address the ANSI ASC X12 standard.

C. ANSI ASC X12 Standard

The purpose of the ASC X12 standard is to provide format specifications for structuring business information (i.e., that information found in "conventional" business documents) which is to be exchanged through EDI. The ASC X12 standard addresses such issues as: [Ref. 2:p. 54]

- What documents can be transmitted electronically?
- What information must be/can be included in each document?
- What is the required sequence of the information?
- What form of information is acceptable (e.g., numeric, ID codes, etc.)?
- What is the meaning of specific pieces of information (data elements)?

What is commonly referred to as the ASC X12 standard is actually a collection of related standards which together provide the desired data format and structure. Of the individual standards which comprise the ASC X12 standard, two categories of standards are of primary significance:

- Transaction Set Standards
- Foundation Standards

1. Transaction Set Standards

For the actual conveyance of information, the transaction set standard is of primary concern. In EDI terminology a transaction set refers to a specific group of data segments which represent a business document. The

information contained in an ASC X12 transaction set is primarily the same as that found on a conventionally printed document. Additionally, in a manner similar to that used with most paper forms, each transaction set is assigned a numeric code, for example, transaction set 858, Shipment Information, is the ASC X12 transaction set used for the electronic exchange of Freight Government bill of lading shipment information.

Transaction set standards provide the guidelines required for structuring the data which is usually conveyed by conventional printed documents, so that it can be electronically exchanged among trading partners. Each transaction set standard addresses three basic components:

[Ref. 6:pp. 9-11]

- Transaction Set Tables
- Data Segments
- Data Elements

As will be discussed, the above order (transaction set - data segment - data element) represents the hierarchical structure found within this EDI standard. For a transaction set: data elements are the smallest unit of data, groups of data elements form data segments, and specified arrangements of data segments (as delineated by transaction set tables) combine to form the actual transaction sets.

To illustrate the EDI concepts relating to transaction set tables, data segments, and data elements, the following discussion will use the Government bill of lading data depicted in Figure 5⁴.

a. Transaction Set Tables

Transaction set tables are the section of the standard which defines the overall format and content of the data contained in a particular transaction set. Each transaction set is composed of one or more tables, with many consisting of a hierarchical arrangement of three tables, which generally relate to the format of the printed document:

[Ref. 6:p. 9]

- Table 1 is the header area, containing information common to the entire transaction such as the date, name and address, and transaction number.
- Table 2 is the detail area, which conveys the actual business transaction. This area contains information pertaining to descriptions, quantities, and prices.
- Table 3 is the summary area. This portion of the transaction consists of information which again relates to the entire transaction such as total weights and charges, as well as transaction set control information.

In defining the overall format and data content of transaction sets, transaction set tables specify which data segments must be used (mandatory), which data segments may be

⁴ The Government bill of lading (GBL), SF1103, is a Government document used for the procurement of freight and cargo transportation and related services from commercial carriers for the movement of material at Government expense. [Ref. 11:p. 257]

U.S. GOVERNMENT BILL OF LADING				ORIGINAL	B/L NO. ► C-1,421,643	
1. TRANSPORTATION COMPANY TENDERED TO CSX TRANSPORTATION INC.		2. SCAC CSXT	3. DATE B/L PREPARED 880523	4. ROUTE ORDER/RELEASE NUMBER 1SXX09995N		
5. DESTINATION (Name, address, and ZIP code) MARINE CORPS MAINTENANCE COMMAND 5880 GATECO BLVD., BLOUNT ISLE JACKSONVILLE, FL 32218		6. SPLIC (Dist.) 491200	9. ORIGIN (Name, address and ZIP code) TRAFFIC MANAGEMENT OFFICE NAVAL WEAPONS STATION CHARLESTON, SC 29408-7000			
8. CONSIGNEE (Name, address and ZIP code of installation) MARINE CORPS MAINTENANCE COMMAND 5880 GATECO BLVD., BLOUNT ISLE JACKSONVILLE, FL 32218		7. SPLIC (Dist.) 447178	10. GBLOC (Code) ICOI	11. SHIPPER (Name, address and ZIP code) TRAFFIC MANAGEMENT OFFICE NAVAL WEAPONS STATION CHARLESTON, SC 29408-7000		
12. APPROPRIATION CHARGEABLE SBE CONTINUATION SHEET #2			13. BILL CHARGES TO (Dept./agency, bureau/office mailing address and ZIP code) COMMANDING GENERAL, 470 MARINE CORPS LOGISTIC BASE ALBANY, GA 31704-5000			
14. VIA (Route shipment when advantageous to the Government) CSXT			AGENCY LOC CODE			
15. MARKS AND ANNOTATIONS (If extra services are ordered, see Administrative Directions No. 2 on reverse) RAIL ARMED GUARD ESCORT SERVICE REQUIRED SEE SHEET #3 FOR SPECIAL INSTRUCTIONS						
M/F:: MV ANDERSON						
16. PACKAGES		17. DIM	18. DESCRIPTION OF ARTICLES (Use carrier's classification or tariff description if possible, otherwise use a clear narrative description)	19. WEIGHT * (Pounds only)	FOR USE OF BILLING CARRIER ONLY	
NO.	KIND				Services	Rate
13	C/L		CLASSIFICATION ITEM NO CLASS "A", "B", "C" EXPLOSIVES AND INERT MATERIAL AS DESCRIBED ON ATTACHED PAGES. "THIS GBL CONSISTS OF 126 PAGES." "SEE ATTACHED PAGES FOR PLACARDING"	2,868,163		
				TOTAL CHARGES		
20. TARIFF/RATE AUTHORITY CSXT 0583 EFF 6/30/87			21. PICKUP SERV. FURNISHED <input type="checkbox"/> YES VEHICLE FULLY LOADED <input type="checkbox"/> YES	22. CARRIER WAY/FREIGHT BILL NO. AND DATE		
23. STOP THIS SHIPMENT AT			24. FURNISH INFORMATION OF CAR/TRUCK/LOAD/CONTAINER SHIPMENTS			
			INITIALS & NO.	SEAL NUMBERS	LENGTH/CUBE	MARKED CAPACITY
					ORDERED FURNISHED	DATE FURNISHED
					89' 4" 89' 4" 149000 149000	5/24/88
			APPLIED BY:			
25. CARRIER'S PICKUP DATE (Year, month & day) 88/05/25			26a. SIGNATURE OF AGENT	26b. PER	B/L NUMBER ► C-1,421,643	
27. MODE M	28. ESTIMATE \$71,656	29. NO. OF CBL/TLS 33	30. TYPE RATE	31. PIC	32. REASON	
			Received by the transportation company named above, subject to conditions named on the reverse hereof, the property hereinafter described, in apparent good order and condition (weights and values unknown), to be forwarded to destination by the said company and returning there, there to be delivered in like good order and condition to said consignee.			
FOR USE OF ISSUING OFFICE			CERTIFICATE OF CARRIER BILLING—CONSIGNEE MUST NOT PAY ANY CHARGES			
33a. ISSUING OFFICE (Name and complete address) TRAFFIC MANAGEMENT OFFICE NAVAL WEAPONS STATION, INNESS, SC CHARLESTON, SC 29408-7000			33b. GBLOC CANM	34a. DELIVERED ON (Year, Month & day) / /	34b. AT (Actual delivery point)	
33c. ISSUING OFFICER JOHN SMITH, TMO			34c. BY (Name of delivering carrier)			
33d. CONTRACT/PURCHASE ORDER NO. OR OTHER			33e. DATED	34d. DELIVERED THIS CONSIGNMENT COMPLETE & IN APPARENT GOOD ORDER EXCEPT AS MAY BE INDICATED <input type="checkbox"/> SHORTAGE <input type="checkbox"/> DAMAGED		
33f. FOB POINT NAMED IN CONTRACT			34e. <input type="checkbox"/> CARRIER OMBD REPORT ATTACHED <input type="checkbox"/> DELIVERY AT DESTINATION FURNISHED <input type="checkbox"/> ACCESSORIAL SERVICES			34f. NAME OF BILLING CARRIER
			34g. SIGNATURE OF CARRIER'S AGENT			
			34h. CERTIFICATION ATTACHED			
*Show also cube measurements for shipments via air, truck or water carrier in cases where required.			NEN7840-00-989-1478 1100-121		STANDARD FORM 1103 (Rev. 4-85) Prescribed by gen. inv. (41 CFR) 101-11.3	

Figure 5 Sample Government bill of lading (GBL)

used (optional), as well as the required order in which the data segments must be arranged. Figure 6 depicts the type of information typically found in transaction set tables. [Ref. 2:pp. 55-56]

858 SHIPMENT INFORMATION

This standard provides the format and establishes the data contents of a shipment information transaction set....This standard does not cover the semantic meaning of the information encoded in the transaction set.

Table 1 - Header Area

Segment ID	Name	Requirements Designator	Max Use
ST	Transaction Set Header	M	1
BX	General Shipment Information	M	1
N1	Name	O	1
N3	Address Information	O	2
N4	Geographic Location	O	1

Table 2 - Detail Area

Segment ID	Name	Requirements Designator	Max Use
<i>(data excluded for illustration purposes)</i>			

Table 3 - Summary Area

Segment ID	Name	Requirements Designator	Max Use
<i>(data excluded for illustration purposes)</i>			

Notes and Comments

Requirements Designator: M = Mandatory data segment O = Optional

Max Use: Maximum use of data segment within a loop

Segment ID: Identifies data segments contained in the transaction set.

Figure 6 Transaction set table (excerpt): ASC X12
Transaction Set 858, Shipment Information

b. Data Segments

The transaction set tables establish which data segments constitute a particular transaction set. A data segment is the intermediate unit of information in a transaction set consisting of functionally related data elements in a specified, predetermined, sequence. The data segment relates to a line of information found on a printed document, such as general shipment information (data segment BX) or an address (consisting of data segments N1, N3, and N4).

Figure 7 depicts an example of the type of information contained in the ASC X12 *Data Segment Directory*. The BX data segment, general shipment information, is illustrated [Ref. 12:pp. 10.7.12-10.7.14]. As shown, the data segment directory defines the required format, structure, and sequence of data segments, and specifies for each data segment: [Ref. 2:pp. 56-58]

- **Data Segment Identifier.** This is an alphanumeric label which identifies each particular data segment. In the preceding example, BX indicates the *general shipment information* data element.
- **Title.** This states the plain language name or title of the specific data segment.
- **Purpose.** This defines what the data segment is used for.
- **Data Elements.** This specifies which data elements are used in a particular data segment, and indicates whether their use is mandatory, optional, or conditional.
- **Data Element Delimiter.** This is a character, most commonly the "*" (asterisk), which precedes each data element. The delimiter indicates where one data element

Figure 7 Data segment BX: General Shipment Information

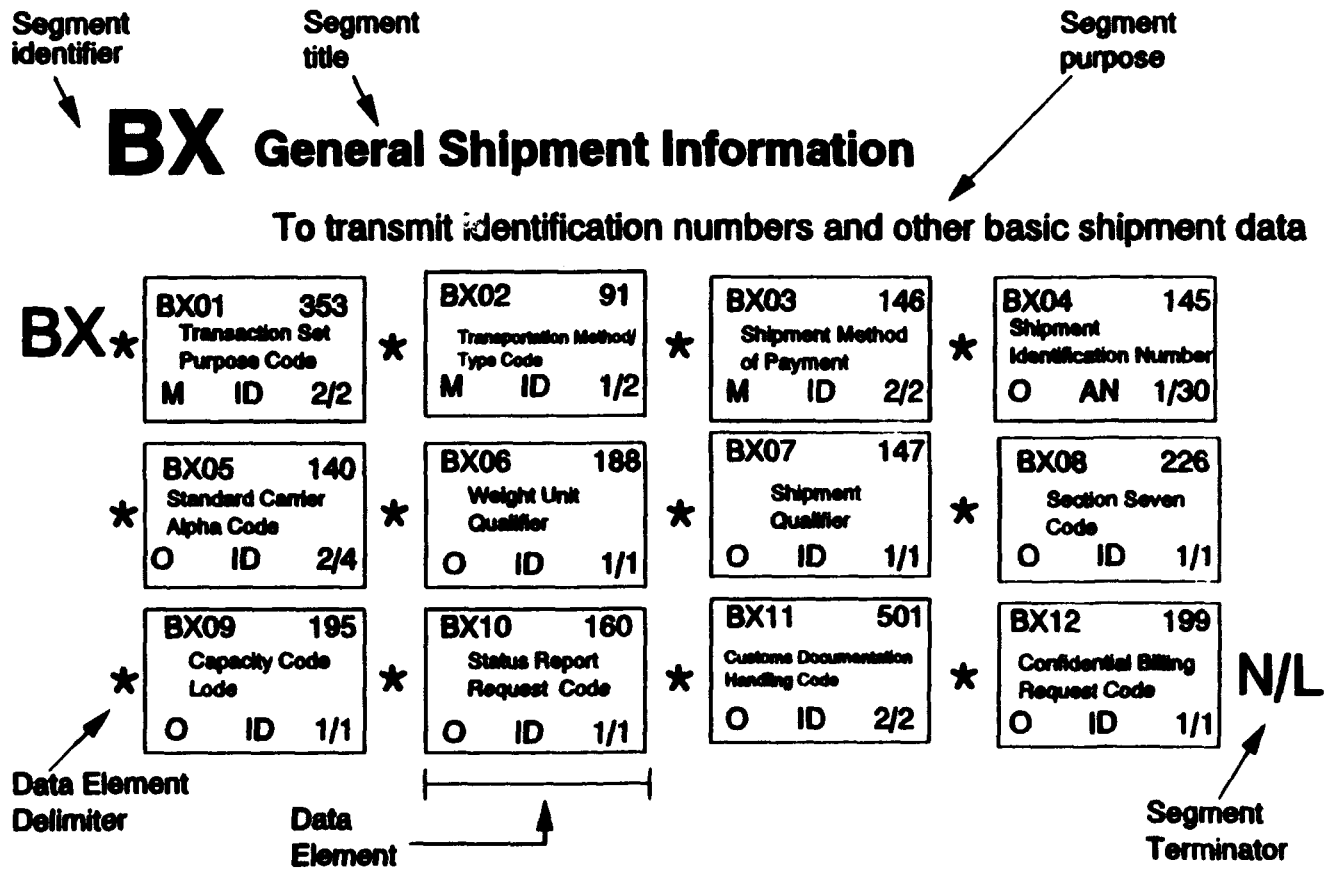

Notes and Comments
 BX05 contains the standard carrier alpha code of the original carrier receiving the shipment

ends and another has begun, and acts as a position marker if an optional element is omitted.

- Data Segment Terminator. This is a character used to indicate the end of the data segment. For illustration purposes, "N/L" will be used as the data segment terminator.
- Notes and Comments. Plain text comments and amplification, as required.

c. Data Elements

The data element is the smallest unit of information in the ASC X12 standard and is defined in the *Data Element Dictionary*. As shown in Figure 8, the data element dictionary specifies for each data element the following information: [Ref. 6:p. 11] and [Ref. 2:pp. 58-60]

- Data Element Identifier. A reference number to the data element dictionary.
- Data Element Title. The plain text name of the data element.
- Data Element Definition. States the purpose of the transaction set.
- Data Element Requirement Designator. Indicates whether the use of the data element is:

M: Mandatory

O: Optional, used at the discretion of the sender. If an optional data element is not used, the data element separator (e.g., "**") must be entered to mark the position.

C: Conditional, data element use is dependent on the use of another element. The specific conditionality requirement is usually included as a note in the Data Segment Directory.

● Data Element Type. Specifies the form of the data:

- N = numeric
- R = decimal
- ID = identification code
- AN = alphanumeric string
- DT = date in YMMDD form
- TM = time in HHMM form (24-hour clock)

● Data Element Length. Indicates the maximum and minimum number of characters allowed.

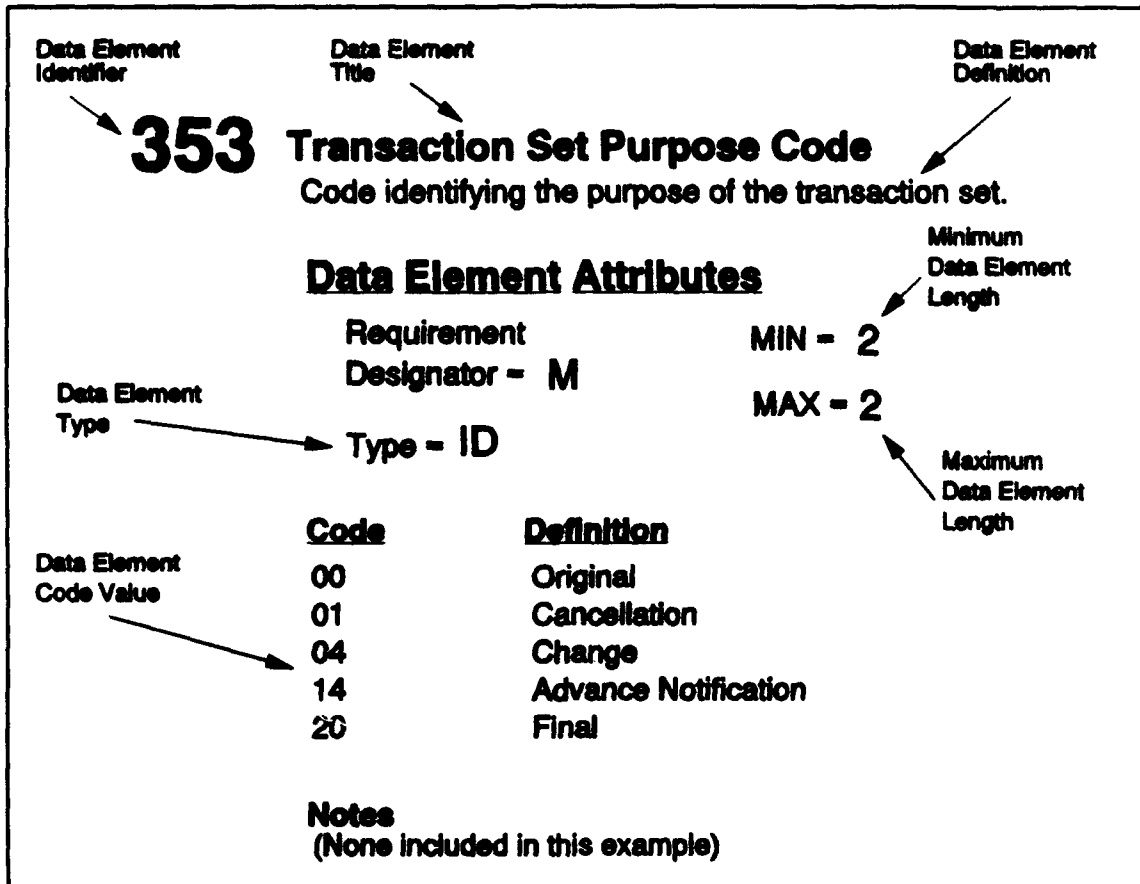

Figure 8 Sample data element dictionary entry (corresponds to data segment BX01 from Figure 7)

Figure 9 illustrates the representation of data elements, as defined in the data element dictionary, through the use of a data element box. The data element box conveys

essentially the same information as the data element dictionary with the addition of the data element reference identifier. The data element reference designator is a two-digit sequence number preceded by the data segment identifier, it identifies the position in which the particular data element appears in the data segment. In Figure 9 BX01 identifies that this particular data element appears first in the sequence of data elements which comprise the BX data segment. This configuration is the one depicted in Figure 7, BX data segment example.

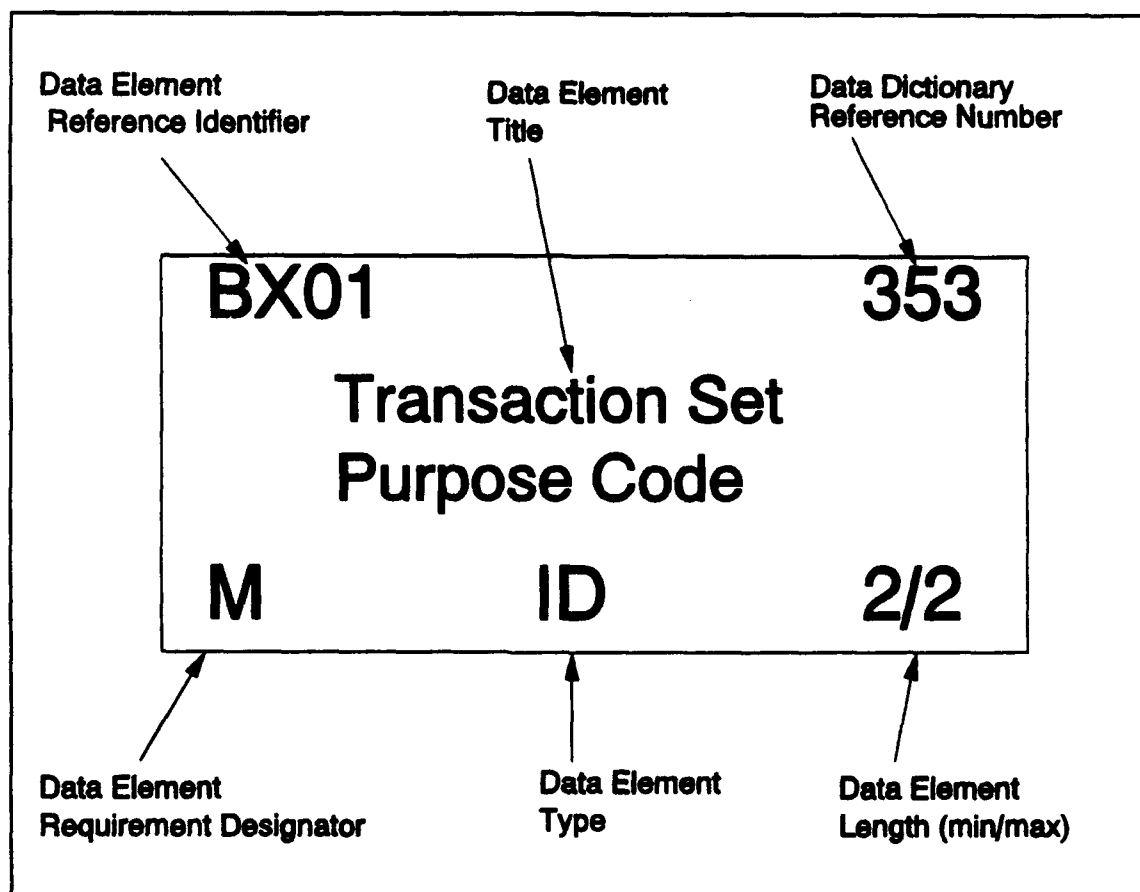

Figure 9 Data element as a data element box

To further illustrate the application of the ASC X12 standard, Figure 10 depicts selected information taken from the Government bill of lading shown in Figure 5, along with the corresponding ASC X12 translation.

Sample GBL Content (selected)	ASC X12 Format (selected)
Transaction Set Purpose: original Transportation Method/Type: rail Method of Payment: collect Identification Number: C-1,421,643 Standard Carrier Alpha Code (SCAC): CSXT Shipment Qualifier: individual shipment Capacity Lode: full capacity	BX*00*R*CC*C1421643*CSXT**B**FN/L
<p style="text-align: center;">Origin</p> Traffic Management Office Naval Weapons Station Charleston, SC 29408-7000	N1*SF*Traffic Management Office N/L N3*Naval Weapons Station N/L N4*Charleston*SC*294087000**447178 N/L
<p style="text-align: center;">Destination</p> Marine Corps Maintenance Command 5880 Gateco BLVD, Blount Isle Jacksonville, FL 32218	N1*ST*Marine Corp Maint. Cmd N/L N3*5880 Gateco Blvd, Blount Isle N/L N4*Jacksonville*FL32218**SL491200 N/L

Figure 10 Selected GBL information translated to ASC X12 format

2. ASC X12 Foundation Standards

ASC X12 has established "foundation standards" which are fundamental to all other ASC X12 standards. These standards define the ASC X12 EDI syntax, data segments, and data elements, as well as the control structure required for

information exchange. The foundation standards are essential for interpreting, understanding, and using the ASC X12 series of transaction set standards. The ASC X12 foundation standards consist of: [Ref. 6:p. 8]

- X12.22 Segment Directory
- X12.3 Data Element Dictionary
- X12.5 Interchange Control Structures
- X12.6 Application Control Structures

a. X12.22 Data Segment Directory and X12.3 Data Element Dictionary

The data segment directory and data element dictionary are used to define the particular segments and elements used in constructing EDI transaction sets. These were addressed previously under the discussion of transaction sets.

b. X12.5 Interchange Control Structures

The X12.5 Interchange Control Structures standard are best thought of as the EDI equivalent of "envelopes." These electronic envelopes consist of specialized data segments which uniquely identify individual transaction sets and functional groups (groups of transaction sets) within an EDI transmission, as well as providing the means to distinguish between individual EDI exchanges.

As shown in Figure 11, the X12.5 standard provides three layers of EDI interchange envelopes: [Ref. 6:pp. 8-9]

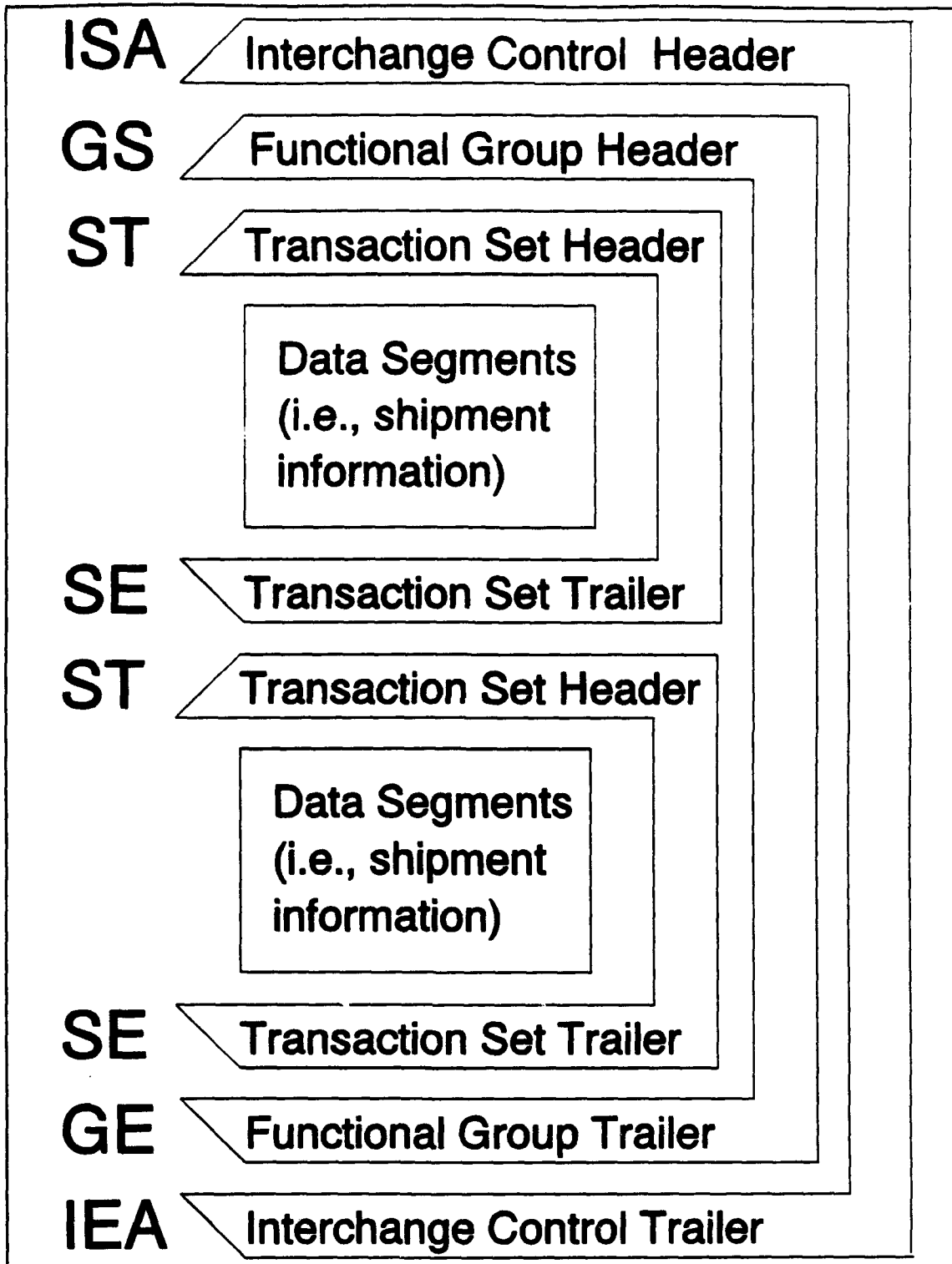

Figure 11 ASC X12.5 Interchange Control Structures standard - Electronic "enveloping"

- Interchange Control Envelope
- Functional Group Envelope
- Transaction Set Envelope

(1) *Transaction Set Envelope*. The transaction set envelope is the innermost level of enveloping and corresponds to the data forming an individual transaction set. This envelope is bound by transaction set header (ST) and transaction set trailer (SE) data segments. An ST data segment indicates the start of a new transaction set, specifies which transaction set is being used, and assigns a transaction set control number. For example, "ST*858*123456789 N/L", indicates the start of transaction set # 858⁵, which is the Shipment Information transaction set and assigns a transaction set control number of "123456789". The SE data segment is used to indicate the end of each individual transaction set. In addition to signifying the end of the transaction set, this segment provides a count of all data segments included in the transaction set and repeats the assigned control number. [Ref. 12: pp. 10.7.5-10.7.128]

(2) *Functional Group Envelope*. The functional group envelope is the middle level of enveloping which surrounds groups of similar transaction sets within an individual EDI transmission. The functional group envelope is

⁵ Transaction set 858, Shipment Information, is defined by ASC X12 standard X12.18.

defined by functional group header (GS) and functional group trailer (GE) data segments. The functional group envelope provides specific information concerning the "enclosed" transaction sets, such as: 1) identifying the type of transaction sets contained in the group (e.g., shipment information, carrier shipment status inquiry, shipment status message, administrative message, functional acknowledgement, etc.), 2) a count of the transaction sets, 3) a date/time stamp of when the group was generated, 4) an assigned group control number, and 5) the version, release, and subrelease of the EDI standard being used within that group. [Ref. 12:pp. 10.2.13-10.2.16]

(3) *Interchange Control Envelope.* The outermost level of enveloping is the interchange control envelope, which is used to identify the transmission of one or more functional groups. This envelope is defined by the interchange control header (ISA) and interchange control trailer (IEA) data segments. As the outermost layer, the interchange envelope contains the addresses of both the sender and receiver of the enclosed "documents," identifies the characters which are to be used for the data element separators and segment terminators, and specifies the format and version of the interchange control segments and the functional group control segments. Other information provided includes an interchange control number, a count of the functional groups within the

interchange, and a date/time stamp. [Ref. 12:pp. 10.2.9-10.2.17]

c. X12.6 Application Control Structures

The X12.6 Application Control Structure is the document which contains the formal description of the EDI architecture and establishes the syntax which governs all other ASC X12 EDI standards. This standard contains the rules, structures, and formal definitions of all terms relating to electronic data interchange. [Ref. 6:p. 8]

D. IMPLEMENTATION CONVENTIONS

As discussed, EDI standards provide the format and structure for the electronic transmission of the essential elements of business documents. Contributing to the extensive reliance on the ASC X12 standard, as opposed to proprietary standards, is the inherent flexibility. This flexibility provides both advantages and disadvantages for the EDI user:

- Advantage: Facilitates widespread application by allowing users to tailor the standards to meet unique requirements, thus satisfying numerous user needs.
- Disadvantage: The potential exists for numerous interpretations concerning the actual implementation of the standards which could result in significantly increasing the complexity of exchanges between trading partners.

The disadvantage created by the inherent flexibility of the X12 standard reflects the situation which exists with many paper documents. As there are many ways to fill out a blank

form, there are also numerous ways to populate an EDI transaction set. In response, implementation conventions (also referred to as implementation guidelines) exist which define the specific rules and requirements for using a transaction set to convey data. The conventions standardize the common practices and/or interpretations concerning the implementation of the ASC X12 standard by specifying the location and values of information found within a transaction set. By providing a common set of implementation rules, the conventions facilitate the successful exchange and interpretation of information among trading partners who conform to the implementation conventions.

EDI standards and implementation conventions are the keys to unleashing EDI's potential for improving the effectiveness of electronic interorganizational communication. Without these, EDI is nothing more than a communications method which may or may not result in the efficient exchange of information among trading partners. It is important to remember that the use of, and compliance with, both the ASC X12 standard and implementation conventions is strictly voluntary. Through the development, approval, implementation, and use of the ASC X12 standard and the corresponding implementation conventions, EDI significantly facilitates the efficient electronic exchange and comprehension of data among trading partners.

IV. ELECTRONIC DATA INTERCHANGE ARCHITECTURE

A. ELECTRONIC DATA INTERCHANGE FUNCTIONS

As defined in Chapter II, electronic data interchange (EDI) involves the computer-to-computer exchange of information, in a standardized, machine-processable format, between organizations. To facilitate this exchange requires the coordination of four resources: computer hardware, computer software, communications connections, and data format standards. The integration of these resources allows an EDI system to perform the following four primary functions required to create and exchange EDI messages: [Ref. 2:p. 80]

- **Mapping:** Data mapping is the process of identifying the relationship between the EDI standard and an organization's internal application system (i.e., between each particular transaction set and an organization's information database). In identifying the relationship, mapping establishes the "link" between the format and structure requirements of the EDI standard and the data contained in an organization's computer system. Data mapping is a step in an organization's EDI implementation effort, and must be accomplished before EDI messages can be exchanged. Once the link is established there is no further requirement to re-map data. The only situation which would result in re-mapping would be a change to the structure of an organization's application system or a change to the particular EDI standard.
- **Extraction (or conversion):** Extraction is the first step in formatting the data to be exchanged through EDI. In this process, data residing in locations which have been previously mapped, is placed in files (commonly referred to as "flat files") prior to the actual structuring to the required format of the EDI standard.

- Translation: Translation is the step where the data is actually structured to and from the EDI standard data format.
- Communications: Communications is the process of conveying data from one trading partner to another.

Together these four functions, along with the system hardware, comprise the EDI system architecture. Figure 12 shows the relationship between these functions in an EDI environment. It is important to note that these functions are generic and not dependent on specific hardware, software, communications protocol, or operating environment. [Ref. 2:p. 80]

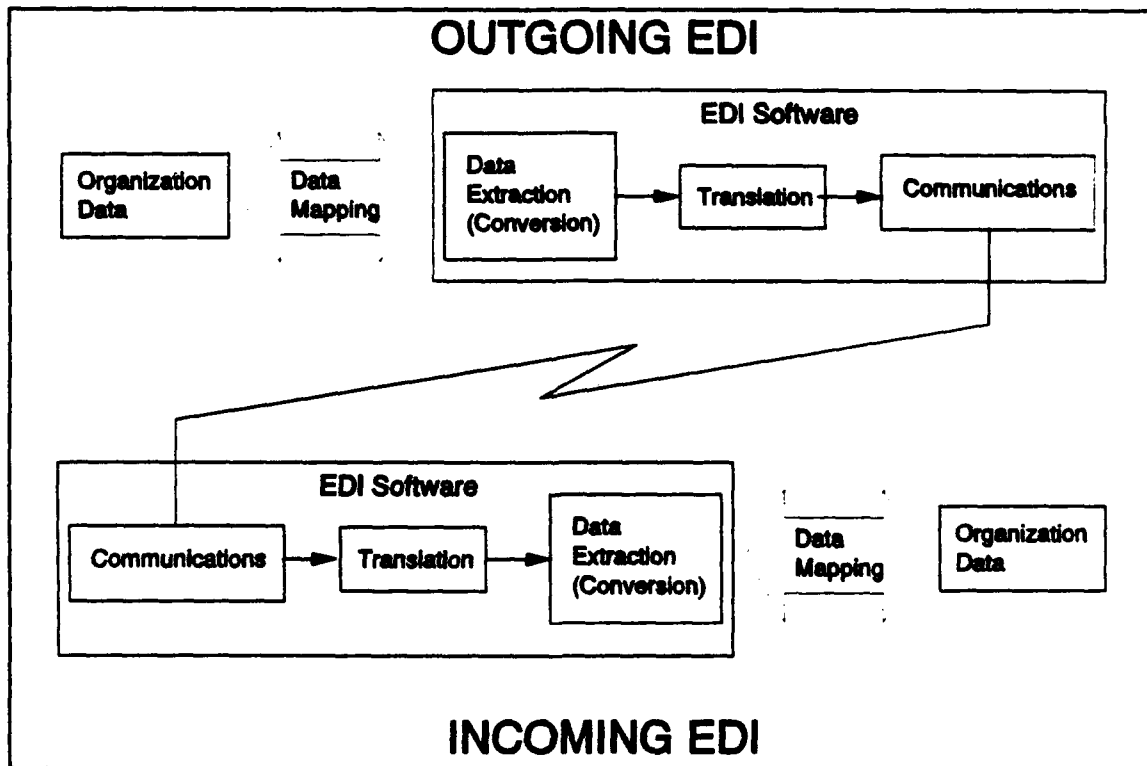

Figure 12 Typical EDI system architecture

B. SYSTEM DESIGN

Of the four resources required for an EDI system, two of these, the computer hardware and the communications connections compose the *System Design*. System design refers to the actual equipment (hardware) as well as the physical communication connections required for the exchange of information electronically in a particular application.

1. Hardware Requirements

Remembering that EDI is a technology implies that there is no *EDI specific* hardware configuration. Although there are numerous hardware systems which are fully capable of supporting EDI applications, Figure 13 illustrates the four basic system hardware options for EDI implementation: [Ref. 2:p. 87]

- **Mainframe Only.** With this option all the EDI software resides on the organization's mainframe computer system. Here the mainframe is used for both internal data processing as well as EDI related functions.
- **Microcomputer (PC-based).** A second option is to have the EDI software reside on a microcomputer (PC) which performs all EDI functions. This arrangement is referred to as "stand-alone" EDI, since the EDI activities are separate from all other computer activity within the organization. When using this approach outgoing data must be manually entered into the PC before it can be exchanged electronically and incoming data must be manually entered into the organization's primary computer system.
- **PC as a Front-end Processor.** A third option is to use a microcomputer linked to the mainframe. With this arrangement, the PC contains all required EDI software and performs all EDI functions. Outgoing data is transferred from the mainframe to the PC (downloading) with incoming data being transferred from the PC to the mainframe

(uploading). As opposed to the stand-alone option, the uploading and downloading is accomplished electronically.

- **Dedicated EDI Operating System.** This final option is basically an extension of the previous method (PC as a front-end processor). The main difference is in the increased capacity to handle a larger volume of transactions.

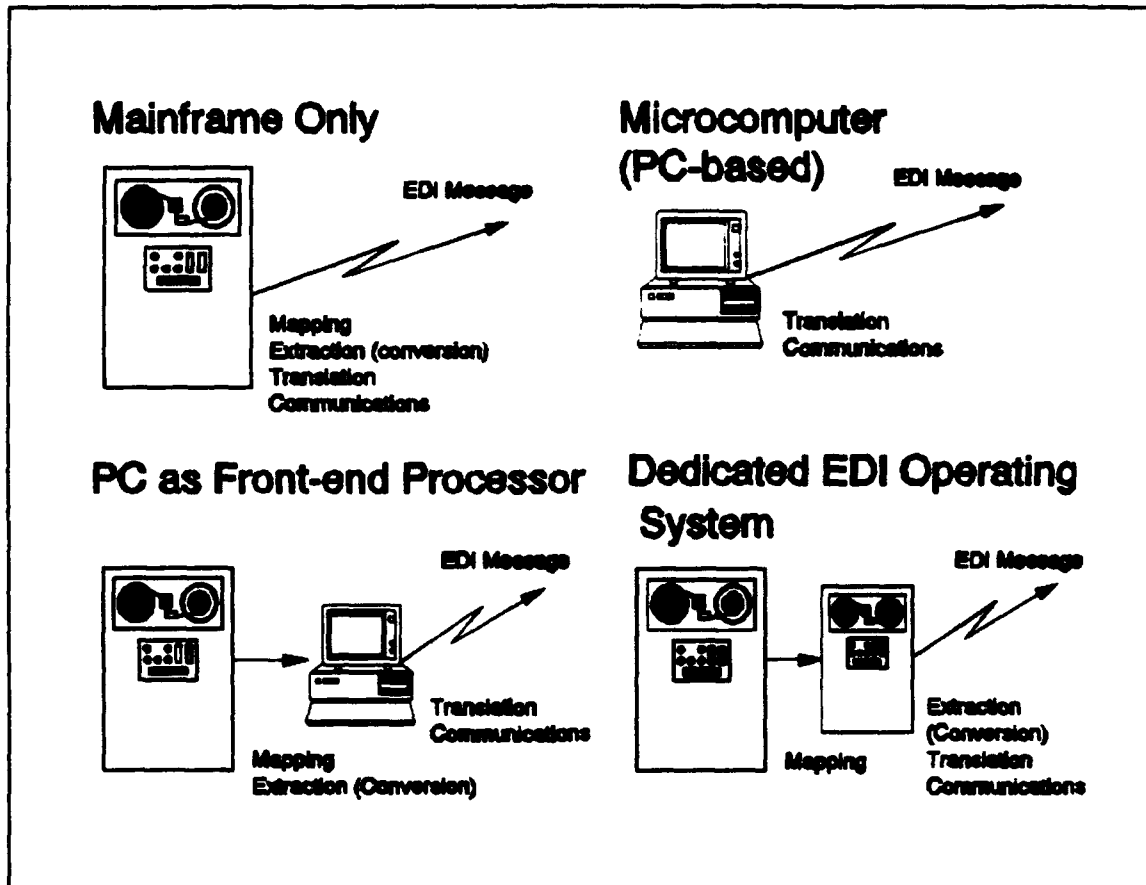

Figure 13 EDI system hardware options

Each application of EDI technology is unique, being situationally dependent on numerous variables such as: organizational commitment to EDI, current and anticipated volume of data to be exchanged via EDI, and budgetary constraints. The specific hardware configuration employed

should be selected based on an evaluation of organizational requirements along with the consideration of the advantages and disadvantages of each of the four basic configuration options, as depicted in Figure 14. [Ref. 2:pp. 87-89]

2. Communications

Electronic data interchange facilitates, and depends on, communication between trading partners. For EDI exchanges to occur between trading partners, the organizations must, in some way, be linked together.

A common misconception is that the adoption of the ANSI ASC X12 standard will eliminate communication barriers between incompatible computer equipment [Ref. 3:p. 75]. The ANSI ASC X12 standard specifies only the format and data content of electronic business transactions, thus eliminating the problem of trading partner computers understanding each other. The standards do not define how the required computer-to-computer communications link shall be established or how the exchange of data is to occur. Issues concerning differences in transmission modes, protocols, and transmission speeds still need to be addressed by the users of these standards. In establishing this vital communications link, there are primarily two alternatives for trading partners to consider:

- Direct
- Value Added Networks (VANs)

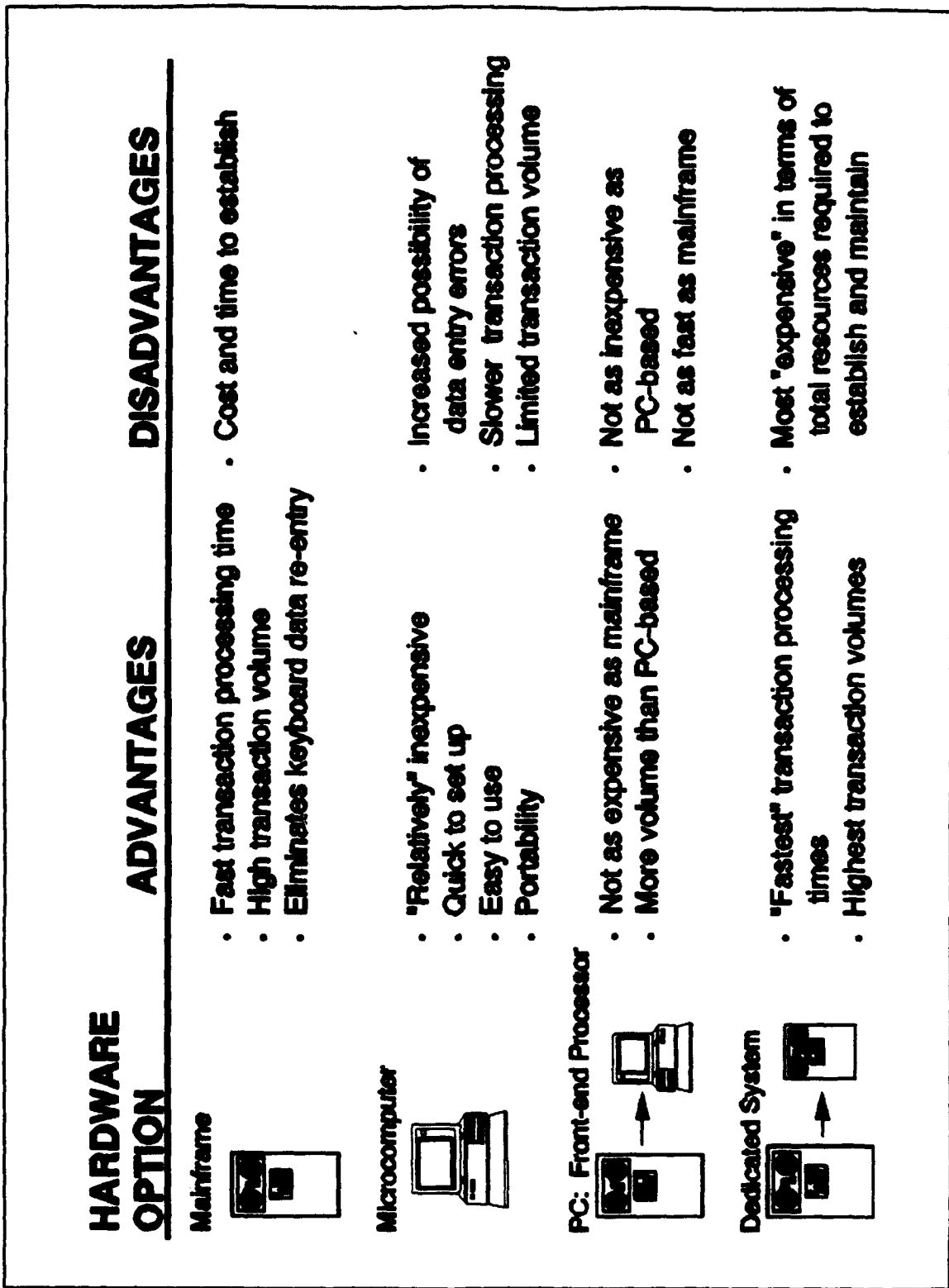

Figure 14 Hardware option advantages and disadvantages

a. Direct

As illustrated in Figure 15, in direct, or point-to-point, EDI, trading partners exchange electronic transmissions directly from the computer of the sender to the computer of the receiver. This linkage is usually achieved through the use of telephone lines coupled with a computer modem.

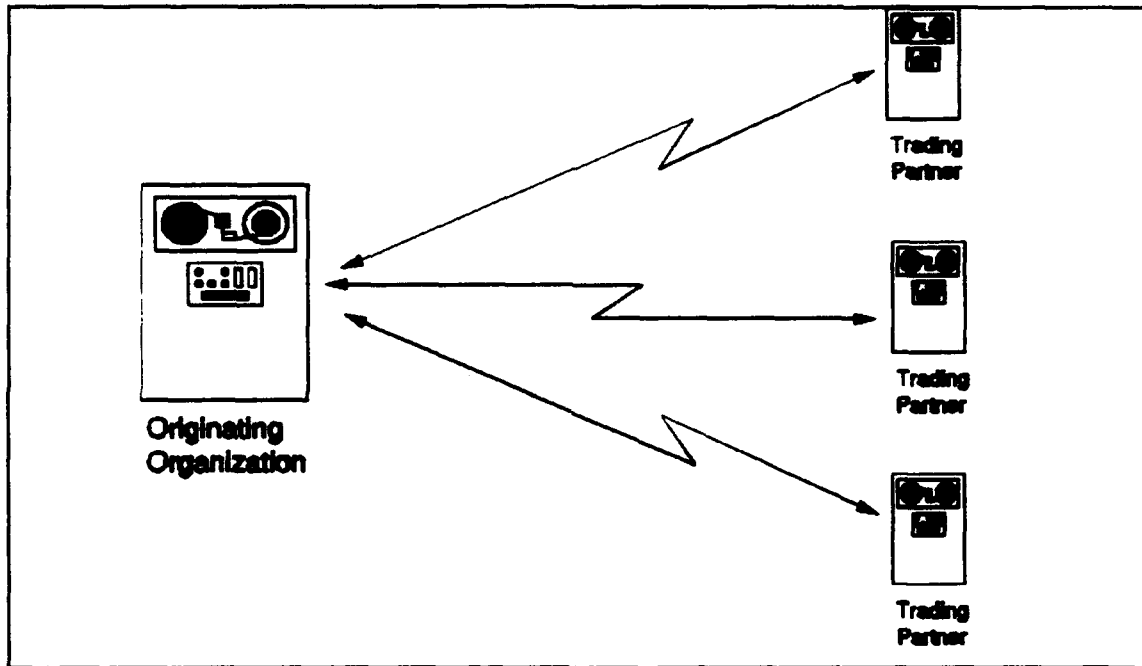

Figure 15 Direct EDI communication linkage between trading partners

For this type of access to work, the trading partners must be compatible from a communications standpoint; this means that they must use the same communication protocols in terms of line speeds and baud rates. The parties must also either use the same standard (e.g., ASC X12) or have the

capability of translating from one standard to another. Additionally, agreements between parties must be reached with regards to the hours of availability of each computer system. With direct linkage, the receiving computer must be free to receive when the sending party transmits a message. [Ref. 2:pp. 101-102]

The direct system is best suited when an organization is communicating electronically with only a few trading partners. As the number of trading partners increases, so does the complexity of establishing and maintaining direct communication links. This increased complexity arises from factors such as: [Ref. 9:p. 29]

- Differences in communication protocols.
- The requirement for prearranged transaction transmission times.
- Transactions sent to separate trading partners must each be individually sent, complicating the connect/disconnect effort.
- Communicating among different time zones.
- Variations in the standards used by the trading partners.

b. Value Added Networks

Some of the concerns encountered with the use of direct linkage, such as differences in communication protocols, times zones, and variations among standards, required to support multiple trading partners, can be alleviated through the use of a value added network (VAN). As

shown in Figure 16, a value added network acts as a "go-between" for organizations wishing to communicate with multiple trading partners.

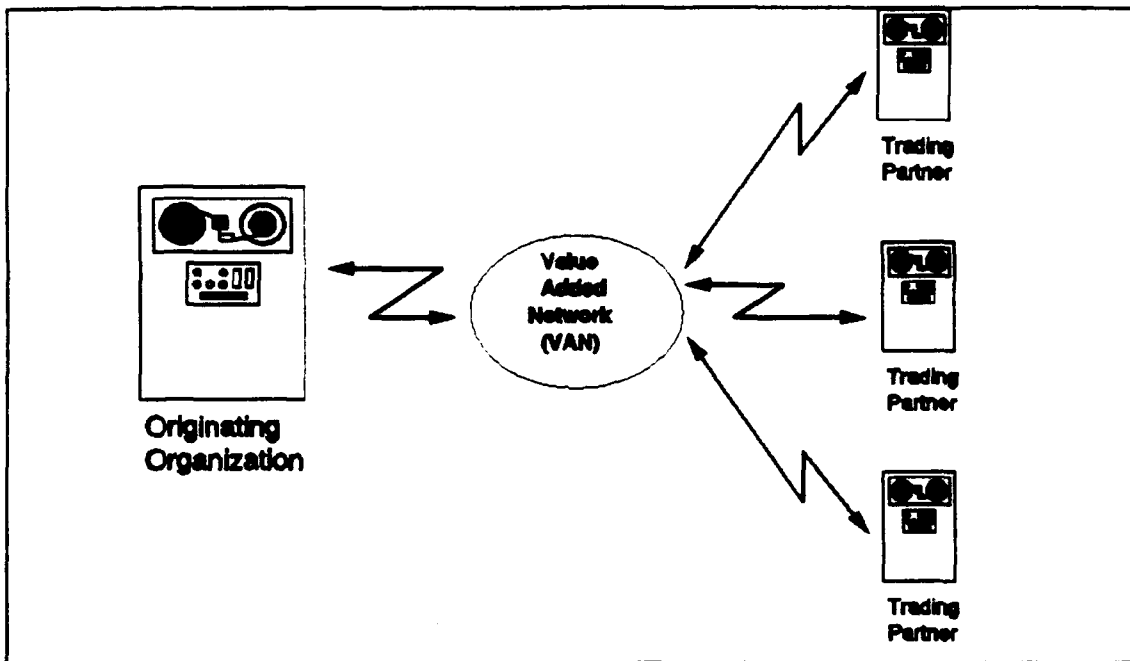

Figure 16 Typical Value Added Network arrangement

The basic function of any value added network is to receive, sort, store, and forward electronic messages. In essence, VANS provide the EDI communications skills, expertise, and equipment necessary to communicate electronically with multiple trading partners. Some of the services which value added networks provide include: [Ref. 9:p. 30]

- Elimination of communications compatibility problems.
- The ability to reach multiple trading partners with "one call".
- Electronic mailbox services.

- The existence of a buffer between your computer and that of your trading partners (instead of direct access between computer systems).
- Standards/format translation.
- Activity reporting and audit information such as maintaining an activity log showing what was received from a particular organization and where it was sent, as well as recording what was placed in an organization's mailbox.

Of the services mentioned above, the most fundamental is the electronic mailbox. In providing this service, the VAN will establish a separate electronic mailbox for each trading partner. As shown in Figure 17, the VAN receives messages (mail) from senders, sorts the messages by intended receiver, and delivers the messages to the receiver's mailbox. One of the primary advantages of the electronic mailbox provided by most VANs is that they allow 24-hour a day, 7-day a week access between trading partners, eliminating the requirement to prearrange transaction times. [Ref. 2:p. 103]

Many communication options exist and there is no "one best method." As with hardware, each organization must evaluate the options available (e.g., direct communications or the use of a value added network), with respect to their particular capabilities and communication requirements, as well as those of their trading partners.

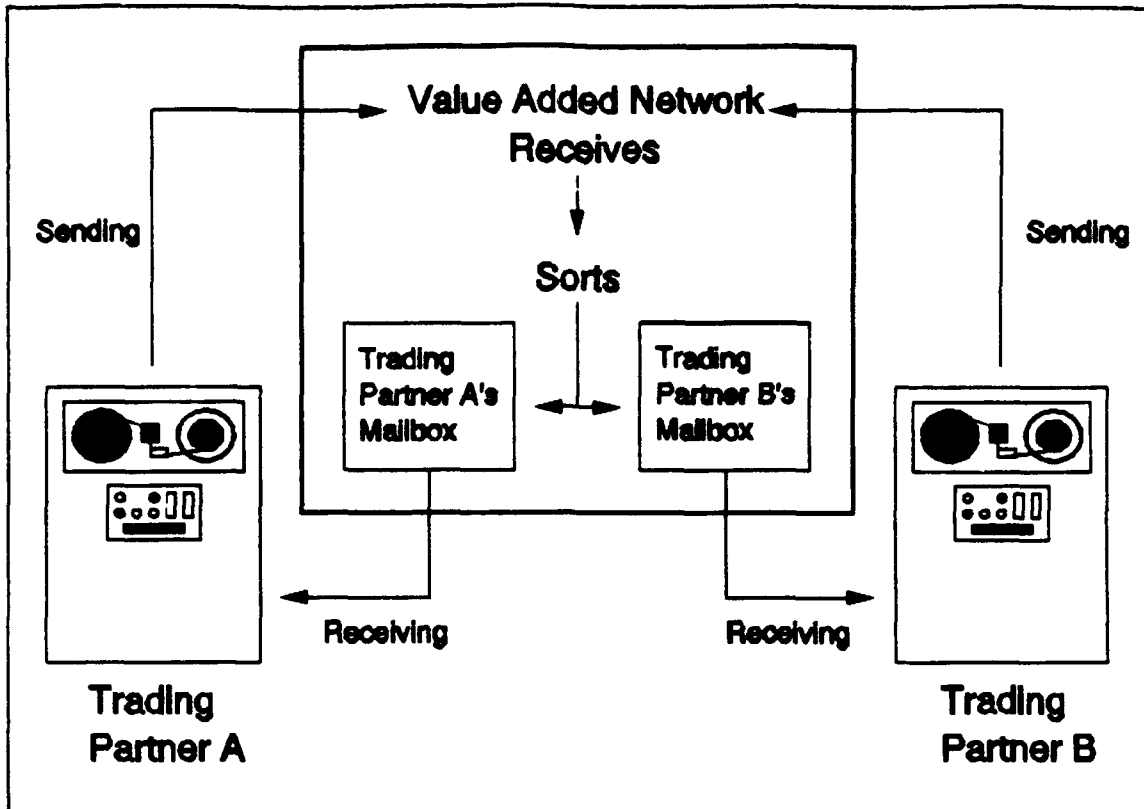

Figure 17 Value Added Network as an Electronic Mailbox

C. SOFTWARE REQUIREMENTS

EDI software provides the set of computer instructions which control the data handling operations of the EDI system. The software is central to the operations which translate data from unstructured, organization-specific, formats into the structured EDI data format (e.g., ANSI ASC X12 standard). In addition to the standard related aspects of an EDI system, software is also used to control required communication interfaces such as establishing the speed and type of transmission and performing error detection during the data

transfer. EDI system software also performs these activities in reverse, receiving the message and then translating it from the EDI standard into the organization-specific data format.

1. Primary Software Functional Areas

Figure 18 illustrates the role of EDI software in performing the primary functions which comprise a typical EDI system architecture, as depicted in Figure 12. Of these, three are performed exclusively by EDI software: 1) Mapping, 2) Data extraction (conversion), and 3) Translation, with the final function, communications, accomplished through a combination of hardware and software. [Ref. 2:pp. 80-82]

a. Data Mapping

The exchange of information through EDI requires the conversion of organization-specific "raw data" into a standardized, machine-processable format. Data mapping is a preliminary step in this conversion process which focuses on information location identification. As a prerequisite of the data extraction (conversion), translation, and communication software functional areas, mapping primarily occurs as part of an organization's EDI implementation efforts. Mapping involves an examination of the standard (e.g., ASC X12) to identify the data required to create an EDI message and then identifying where in the organization that information resides (i.e., where in the organization's database). In identifying this relationship, mapping establishes the "link" between the

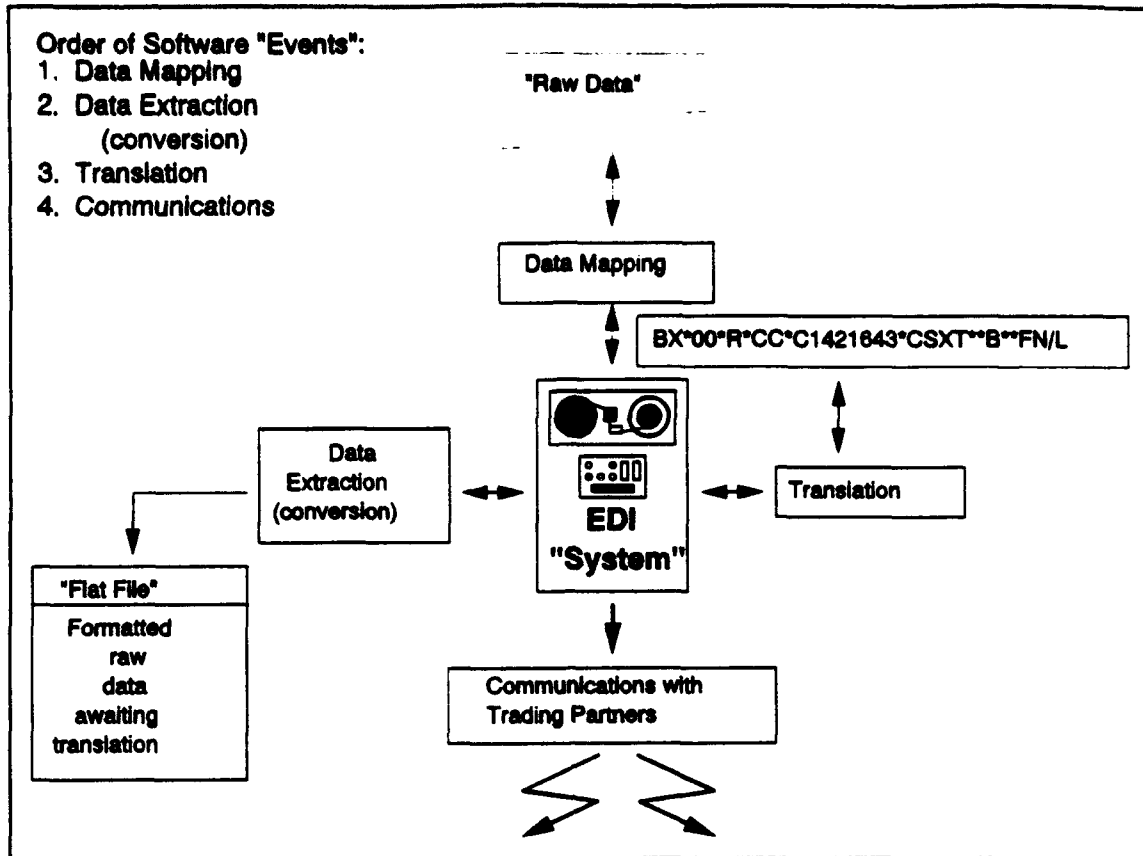

Figure 18 Primary EDI software functions

format and structure requirements of the EDI standard and the data contained in an organization's computer system. Once the link is established there is no further requirement to re-map data. The only occasion which would result in re-mapping would be a change to the structure of an organization's application system or a change to the particular EDI standard.

[Ref. 2:p. 80]

b. Data Extraction (conversion)

Extraction, more appropriately referred to as "conversion," is the process of collecting the previously

identified, mapped, information and converting it into a usable format. Usually, the data are extracted from the organization's database and restructured into a "flat file." This flat file typically consists of fixed-position records and is used to "hold" the data awaiting translation. [Ref. 2: p. 80]

c. Translation

The principal purpose of translation software is to format the data contained in flat files to and from standard transaction set formats (e.g., the 858 transaction set). Translation performs this function for both outbound (generation) and inbound (interpretation) messages.

For outbound messages, generation involves arranging the data in the exact structure necessary to meet the requirements of the standard. To perform the translation, the generation software usually uses a table structure, consisting of the data element dictionary and syntax rules for data segments and elements of the appropriate EDI transaction set. When a transaction set is to be generated, the software selects the appropriate table and performs the translation automatically, with the output being a syntactically correct EDI transaction set. [Ref. 2:p. 80]

For incoming messages the process is reversed. The interpretation software performs similar functions, taking a syntactically correct EDI transaction set and converting it to

a format that the organization's application database can understand.

d. *Communications*

In order to exchange EDI messages, EDI systems must be capable of passing information to and receiving information from established communications links. These activities are controlled by communications software. Some of the typical functions provided by communications software include:

- Automatic dialing
- Managing and maintaining trading partner phone numbers
- Establishing the type and speed of the data transfer
- Data transmission error detection
- Maintaining an activity log of transactions

2. *Additional Software Functions*

In addition to the primary functional areas discussed above, an organization may also utilize the following types of software in their EDI system:

- Bridging software
- Security software

a. *Bridging Software*

As shown in Figure 19, bridging software links various application programs within an organization. This linkage allows incoming EDI messages to be used to generate outbound EDI messages, such as an order receipt

acknowledgement or an automatic response to a status inquiry. As EDI eliminates the need to manually reenter data between organizations, bridging software eliminates the need to manually reenter data between various departments within an organization. Through the use of bridging software, once data enters an organization's computer system the information is available to "flow" between internal applications as required; this is indicated by the double-headed arrows in Figure 19. [Ref. 2:pp. 83-84]

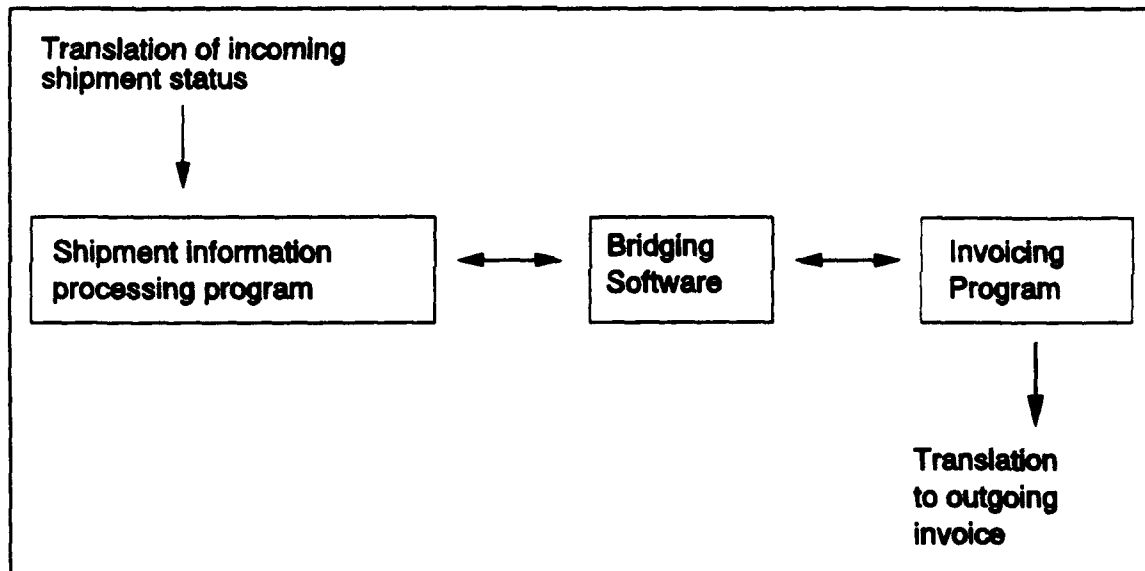

Figure 19 Bridging software application

b. Security Software

Chapter II highlighted the importance of, and growing concern over, the security of EDI systems. The two types of cryptographic security discussed, encryption and authentication, are software approaches addressing this

concern, and they can be integrated into an EDI system as the situation warrants.

The foregoing discussion presented the range of potential EDI software functions. The actual software functions performed in an individual organization's EDI system will primarily depend on whether an application-to-application or a door-to-door approach is taken.

With an application-to-application approach to EDI, information flows directly from the sender's application database to the recipient's without human intervention. In this case, the EDI system software will provide all four of the primary functions of data mapping, conversion, translation, and communications.

In contrast, with a door-to-door approach, manual input is used to generate an outgoing transaction set, and the incoming transaction set is manually read and interpreted. Here, the only functions performed by the EDI system software are those of translation and communication. The mapping and conversion functions are accomplished through manual input and interpretation.

The application-to-application and door-to-door approaches represent the two extremes concerning the level of integration of EDI with the computer system of an organization. As more organizations implement EDI technology, it is increasingly likely that there will be situations where a mixed approach is encountered. In this context, a mixed

approach would simply be a situation where one trading partner might have EDI fully integrated with its computer system while its trading partner may be utilizing a microcomputer based approach to EDI transactions. An example of this would be Roadway Express, Inc., where Roadway has taken an integrated approach on the application-to-application end of the spectrum yet many of its smaller trading partners are utilizing a door-to-door level of EDI integration.

As discussed, the choice as to the appropriate EDI System, composed of hardware, communications, and software, will be situationally dependent. The specific configuration selected will be determined by the specific needs and resources of the parties involved. As transaction volume and available resources allow, maximum benefits will be attained with a greater implementation of EDI in the transaction process (e.g., an application-to-application approach, where data is exchanged electronically with minimum human intervention).

V. DEPARTMENT OF DEFENSE IMPLEMENTATION OF ELECTRONIC DATA INTERCHANGE

A. ELECTRONIC COMMERCE

Like many organizations, the Department of Defense relies on a multitude of manual and automated systems to carry out its business functions, such as acquisition, logistics, and transportation. Though effective, these systems are not necessarily the most efficient means of accomplishing the required tasks. With the existing environment of diminishing resources, efficiency in operations continues to take on increased significance. As organizations respond to pressures to "do more with less," advances in information technology emerge which offer increased capabilities and efficiencies in conducting these business functions.

The Department of Defense, in an effort to take advantage of emerging electronic information technology capabilities, has adopted the approach of *Electronic Commerce*, the digital exchange of all information needed to conduct business. DoD's concept of Electronic Commerce (EC) involves the integration of electronic data interchange, electronic mail, electronic bulletin boards, electronic funds transfer, and related technologies into a comprehensive electronic-based system which encompasses all DoD business functions. The EC concept

is focussed on exchanging business information faster, making information more accessible, and sending information directly to those who need it. The objective of DoD's EC program is not to just automate existing manual processes, but to implement the necessary systems, capabilities and procedures which will allow DoD activities to fundamentally alter and improve the manner in which they accomplish their business operations. [Ref. 7:p. 1-2]

Although EC encompasses a variety of electronic information processing technologies, the key to DoD changing its business practices, from a paper-based document processing to a total electronic environment is electronic data interchange. The DoD name for this initiative is "Electronic Commerce through EDI." [Ref. 13:p. 1-1]

B. ELECTRONIC COMMERCE THROUGH EDI

1. Policy Milestones

The strategic goal of DoD's current EDI efforts is to provide the capability to initiate, conduct, and maintain its external and internal business related activities utilizing an electronic media [Ref. 14:p. 3]. In the process of implementing DoD's EDI initiatives, the following policy milestones have occurred:

- Deputy Secretary of Defense (DEPSECDEF) memorandum commits DoD to industry EDI standards (May 1988).
- Treasury endorses DoD plan to use electronic funds transfer (EFT) (March 1989).

- Title 41, Code of Federal Regulations changed to permit using EDI for documenting and paying transportation bills (April 1989).
- Defense Logistic Agency (DLA) appointed as Executive Agent (EA) for EDI (May 1990).
- Defense Management Report Decision (DMRD) 941 commits DoD to replace identified documents, key EDI candidates, with the appropriate EDI equivalent transaction set (November 1990).
- Federal Information Processing Standards Publication (FIPS PUB) 161 established the rules and formats for conveying information electronically (March 1991).
- DoD EDI Program Management responsibilities transferred from DLA, formerly the Executive Agent, to the Defense Information Systems Agency (DISA) (April 1993).

In examining these milestones, two policy documents stand out as significant to establishing the foundation for DoD's EDI efforts:

- Deputy Secretary of Defense memorandum of 24 May 1988 - Electronic Data Interchange of Business-Related Transactions.
- Defense Management Report Decision 941 - Implementation of Electronic Data Interchange in DoD.

a. DEPSECDEF Memo

In May of 1988, the Deputy Secretary of Defense issued a memorandum specifying that EDI was to "become the way of doing business" for the Department of Defense. Recognizing the potential benefits of EDI, Deputy Secretary Taft directed that: [Ref. 15]

Consistent with our commitments to improve productivity and move toward a paperless environment, all DoD components should make maximum use of electronic data

interchange (EDI) for the paperless processing of all business-related transactions.

Additionally, this memorandum specified the standard which would be used by DoD in the conduct of business via EDI. Specifically: [Ref. 15]

The American National Standards Institute X12 uniform standards for inter-industry electronic interchange of business transactions will be employed as the standard for EDI, providing a common approach to implementation and a single, coordinated DoD position to industry.

b. DMRD 941

In November 1990, Defense Management Report Decision (DMRD) 941 was approved by the Deputy Secretary of Defense. DMRD 941 directed the development, implementation, and management of a standard DoD EDI system. As part of the move to a "paperless" environment, DMRD 941 identified 16 forms and documents as "key EDI candidates," initiating their replacement with their electronic equivalents.

2. Organization

The Assistant Secretary of Defense for Production and Logistics, ASD (P&L), was initially given responsibility for oversight of EDI development efforts within the Department of Defense. The ASD (P&L) in turn designated the Defense Logistics Agency (DLA) as the Executive Agent (EA) for managing the funding, development, and implementation of a standard DoD EDI system. [Ref. 14]

The EA for EDI was established to encourage and coordinate the implementation of EDI within DoD. As DoD's

Executive Agent for EDI, DLA's responsibilities included:

[Ref. 13:p. 3-1]

- Developing DoD-wide strategies for implementing EC/EDI.
- Providing and maintaining standard implementation guidelines for EDI.
- Ensuring compliance with policies and standards.
- Providing common-user support standards and services for use throughout DoD.
- Promoting EDI implementation by focusing on broad DoD and industry implementation opportunities.
- Promoting a "single face to industry" for DoD EDI efforts.

In April of 1993, DoD EDI Program Management responsibilities were transferred from DLA to the Defense Information Systems Agency (DISA). In assuming these duties, the Defense Information Systems Agency is responsible for the execution of the Department of Defense EDI technical infrastructure and related operations. [Ref. 16:p. 2]

3. Proposed Savings and Benefits

As resources continue to diminish, it is increasingly necessary for DoD to develop, implement and utilize processes which maximize efficiency and maintain required levels of readiness while remaining within budgetary constraints. Through the implementation of EDI, DoD and its trading partners expect to derive many of the cost reduction and efficiency benefits discussed in Chapter II, specifically:
[Ref. 14:p. 2]

- Reduction in paper handling costs.
- The elimination of duplicate data entry.
- Payment systems which work faster with fewer errors.
- Better decision making due to more accurate and timely data.

One of the first steps in DoD's implementation of EDI, and the realization of corresponding benefits, was the identification of those documents whose information would eventually be exchanged through EDI. In 1990 DoD had over 2,100 documents which were potential candidates for EDI. Of this total, almost two-thirds of the documents (1,395) were standardized Defense Department (DD) forms; 155 were General Services Administration Standard Forms (SF); with the remaining documents (almost 600) being either service-specific, internal, or interagency forms. [Ref. 13:p. 2-1]

In the process of identifying which documents to "start with", the first step was the identification of areas of opportunity within DoD. Using primarily private-sector experience in EDI as a guide, four key opportunity areas were identified: 1) procurement and contract administration, 2) transportation, 3) supply and maintenance, and 4) fuels. [Ref. 13:p. 2-1]

With these key opportunity areas identified, the next task was to determine, within these areas, which routine paper documents offered the greatest EDI potential. In selecting

these documents, emphasis was placed on the following criteria: [Ref. 13:p. 2-2]

- The document should be used extensively throughout DoD.
- Currently the document should be manually processed.
- The document should have multiple users (this dramatically increases both the amount of paper flowing through the system and the labor required to process the paper).
- The document should have a private-sector counterpart (would help to ease acceptance and replacement through EDI).

Using these criteria, 16 documents⁶ were identified as having the greatest potential for return on investment, and were designated as the "key EDI candidates."⁷ Table I identifies these documents and their associated annual volumes by opportunity areas.³ [Ref. 14: Table 1]

For the documents identified, the total anticipated benefits associated with EDI implementation can be classified as either:

- Direct Cost Savings
- Indirect Cost Savings

⁶ Some of the documents identified (e.g., SF 18 and SF 30) are processed in different ways. Each variation is treated separately.

⁷ Appendix B contains additional information on each of these documents.

⁸ The numbers shown are 1990 estimated annual volumes.

TABLE I KEY EDI CANDIDATES

Documents by Opportunity Area		Estimated annual volume (millions)
Procurement and Contract Administration		
DD Form 1155	Order for Supplies and Services	11.00
SF 18	Request for Quotation (written)	5.40
SF 18	Request for Quotation (Telephone)	4.00
SF 30	Amendment of Solicitation/Contract Modification (Local)	3.75
SF 30	Amendment of Solicitation/Contract Modification (Non-Local)	0.25
DD Form 250	Material Inspection and Receiving Report	2.50
SF 129	Solicitation Mailing List Application	1.00
SF 1443	Contractor Request for Progress Payments	0.40
Transportation		
SF 1103 SF 1113	Freight GBL, CBL, and Public Voucher	2.30
SF 1203 619/619-1 SF 1113	Personal Property GBL, Statement of Accessorial Services Performed, and Public Voucher	0.80
SF 1169 SF 1113	Government Travel Request and Public Voucher	0.39
-----	Voucher Stub and Check	0.27
MT 364R	Standard Tender	0.03
Supply and Maintenance		
SF 364	Report of Discrepancy	0.30
SAV 926	Monthly Report, Receipt of Repairables	0.28
SF 368	Product Quality Deficiency Report	0.10
SF 361	Transportation Discrepancy Report	0.03
Fuels		
DD Form 1898	Aviation Fuels Sales Slip	0.30

Note: GBL = Government Bill of Lading; CBL = Commercial Bill of Lading; MT = MTMC; SAV = Standard Aviation Systems Command

a. Direct Cost Savings

Within DoD, the manual process of document handling consists of several labor intensive and costly activities including: document distribution (making copies of documents and distributing them to users); mailing (primarily postage and the purchase of envelopes); document receipt (sorting and routing); document processing (reconciling and auditing); document preparation (for data entry); data entry (which can involve multiple entries if the information is entered into more than one computer system); error resolution (checking for and correcting mistakes); document storage and retrieval; and telephone procurement. With the implementation of EDI, most of these manual procedures are eliminated with the resulting savings defined as direct cost savings. [Ref. 14:p. 4]

In determining the direct cost savings associated with the elimination of these manual document processing activities, engineered work standards were used. These work standards, supplied by the U.S. Army Finance and Accounting Center, detail the labor content and time allotment for performing the manual activities described above. The direct cost savings associated with the elimination of these activities were obtained by multiplying the work standards by the appropriate Government Schedule (GS) labor rate. Table II is structured to show the predominant manual document handling operations along with activities commonly associated with their occurrence. Reflecting that all documents are not

TABLE II EDI DIRECT COST SAVINGS*: PER ACTIVITY, PER DOCUMENT

Operation	Activity	Comment ("Costs increase with...")	Cost Category (\$)		
			Low	Medium	High
Document distribution	Separate documents, make copies, route to mail room, prepare address labels, stuff envelopes	complexity of operations	0.02	0.04	0.06
Mailing	Procure envelopes and stamps	number of documents requiring single envelopes	0.11	0.16	0.26
Document receipt	Receive, open, sort, date, stamp, route	complexity of sorting	0.01	0.02	0.03
Document processing	Match, reconcile, audit	document complexity and data volume	0.15	0.26	0.41
Document preparation and control	Examine and prepare for data entry	document complexity	0.13	0.21	0.47
Data entry	Enter data	volume of data	0.06	0.17	0.68
Error resolution	Research and correct errors, prepare correspondence	volume of data	0.05	0.07	0.09
Document storage and retrieval	Log, separate, sort, microfilm, box, file, retrieve documents	filing and microfilming requirements	0.10	0.16	0.28
Telephone Procurement	Procure material and services	number of telephone solicitations	1.78	3.50	5.33

* Cost category figures are based on 1990 data.

processed in the same fashion, Table II also shows the per-activity, per-document direct cost savings segregated into low, medium, or high cost categories. [Ref. 14:p. 4, Table 2]

In estimating the total direct cost savings, level of effort determinations were made for those DoD activities (e.g., procurement office, transportation office, receiving office, etc.) involved with the handling and processing of the associated documents. This level of effort information was in turn used to calculate the expected savings per-document information displayed in Table III, by identifying the appropriate costs to apply from the low, medium, or high cost categories shown in Table II. Additionally, all operating costs, except telecommunications, were assumed to remain constant. With telecommunication costs expected to increase in an EDI environment, these costs were subtracted from the direct cost savings. Using the savings per-document data along with the estimated annual volume information from Table I, the resulting annual net savings associated with each of the identified documents was computed. Table III provides the total savings information for each opportunity area as well as the overall, expected total. [Ref. 14: Table 3]

As depicted in Table III, if all documents identified as key EDI candidates were replaced with appropriate EDI transaction sets, the estimated annual direct cost savings to DoD could be \$98 million. Additionally, Table III shows that a majority of the potential savings (\$84.5 million or 86 percent) are associated with the procurement and contract administration functional area. The projected savings in transportation would contribute \$11.8 million

TABLE III SUMMARY OF TOTAL DIRECT COST SAVINGS

Document by Opportunity Area		Estimated annual volume (millions)	Savings per document (\$)	Total savings (\$ millions)
Procurement and Contract Administration				
DD Form 1155	Order for Supplies and Services	11.00	3.36	36.9
SF 18	Request for Quotation (written)	6.40	0.84	4.6
SF 18	Request for Quotation (Telephone)	4.00	3.45	13.8
SF 30	Amendment of Solicitation/Contract Modification (Local)	3.75	3.36	12.6
SF 30	Amendment of Solicitation/Contract Modification (Non-Local)	0.25	3.98	1.0
DD Form 250	Material Inspection and Receiving Report	2.50	5.72	14.3
SF 129	Solicitation Mailing List Application	1.00	0.94	0.9
SF 1443	Contractor Request for Progress Payments	0.40	1.27	0.5
Subtotal				84.6
Transportation				
SF 1103 SF 1113	Freight GBL, CBL, and Public Voucher	2.30	3.12	7.2
SF 1203 619/619-1 SF 1113	Personal Property GBLs, Statement of Accessorial Services Performed, and Public Voucher	0.80	4.45	3.6
SF 1169 SF 1113	Government Travel Request and Public Voucher	0.39	1.87	0.7
.....	Voucher Stub and Check	0.27	0.87	0.2
MT 364R	Standard Tender	0.03	2.28	0.1
Subtotal				11.8
Supply/Maintenance				
SF 364	Report of Discrepancy	0.30	2.08	0.6
SAV 926	Monthly Report of Reparables	0.28	1.80	0.6
SF 368	Product Quality Deficiency Report	0.10	1.47	0.1
SF 361	Transportation Discrepancy Report	0.03	1.29	0.1
Subtotal				1.3
Fuels				
DD Form 1898	Aviation Fuels Slip	0.30	1.26	0.4
Subtotal				0.4
Total				98.0

(12 percent) annually, with supply/maintenance and fuels contributing an estimated \$1.3 million and \$0.4 million respectively. Based on the analysis presented in DMRD 941,

DoD has the potential to realize total direct cost savings of \$98 million annually, provided that all the key candidate documents are replaced by their electronic equivalents.

b. Indirect Cost Savings

While the direct cost savings resulting from the implementation of EDI are substantial, they are only part of the total cost savings equation. The indirect benefits associated with EDI are also significant and many private sector organizations have found that the indirect cost savings resulting from EDI outweigh the direct cost savings. Examples from the private sector include: inventory reductions, improved customer service, reduced manufacturing costs, streamlined operations, and increased asset visibility. In addition to these benefits it is expected that DoD will also experience improved quality control, enhanced contract management, better prepayment auditing, increased price discounts, and reduced interest payments. [Ref. 14:p. 5]

In an analysis of the indirect cost savings expected from the electronic exchange of the key EDI candidate documents, the Logistics Management Institute (LMI) performed an economic analysis involving: 1) inventory reduction, 2) streamlined and enhanced business operations, 3) reduced prepayment auditing, 4) avoidance of interest costs, 5) negotiated price reductions and discounts, and 6) reduced shipment tracing. In the six areas of indirect benefits

examined, it was estimated that with a fully implemented EDI system DoD could save between \$152 million and \$301 million annually in indirect costs, between \$1.55 and \$3.07 for every dollar of direct savings. [Ref. 13:pp. 2-8 - 2-12]

As a result of the LMI analysis, it was determined that an indirect to direct cost savings ratio of 1.8 to 1 was appropriate for calculating the indirect cost savings correlating to the documents discussed above. Applying this ratio to the projected \$98 million direct cost savings, yields an indirect cost savings of \$176 million as the projected annual indirect costs savings. [Ref. 14:p. 6]

c. Total Direct and Indirect Cost Savings

Adding these projected direct and indirect cost savings results in a potential \$274 million annual total cost savings, if DoD were to utilize EDI in the electronic exchange of all documents identified in Table I. Though the calculations presented in the LMI report (A Business Case for Electronic Commerce) and DMRD 941 tended to be intentionally conservative, actual total cost savings will be influenced by several factors. Foremost among these factors are the indirect to direct cost savings ratio and the EDI implementation rate.

Through the implementation of EDI, DoD has the potential to substantially reduce its cost of conducting business. Extrapolating on the experiences of the commercial

sector, it is anticipated that the greatest benefits of EDI implementation will not come from the direct cost savings but from the indirect benefits associated with the critical role EDI has in supporting and streamlining business procedures.

VI. DEFENSE TRANSPORTATION ELECTRONIC DATA INTERCHANGE IMPLEMENTATION

A. DEFENSE TRANSPORTATION OVERVIEW

The objective of defense transportation can be summarized as having the capability to satisfy military transportation requirements during times of peace and war, with emphasis on service, economy, and readiness. The major players in defense transportation, which is concerned with the movement of DoD forces, equipment and supplies, consist of:

- United States Transportation Command (USTRANSCOM)
- Air Mobility Command (AMC)
- Military Traffic Management Command (MTMC)
- Military Sealift Command (MSC)

1. United States Transportation Command

The United States Transportation Command (USTRANSCOM) is designated as the single manager of Department of Defense common-user transportation⁹. The broad USTRANSCOM mission is to provide global air, land, and sea transportation to meet national security needs. It supports the other unified and

⁹ Common-user transportation assets consist of those assets either government-owned or -chartered that are under the operational control of AMC, MSC, or MTMC for the purpose of providing common-user (available and utilized by all services) transportation to DoD in peace or war. [Ref. 17:p. I-8]

specified commands by managing and providing its components' common-user transportation forces in peace and war. Established in April 1987, USTRANSCOM is a unified command with three transportation component commands (TCCs): the Air Force's Air Mobility Command (AMC), the Army's Military Traffic Management Command (MTMC), and the Navy's Military Sealift Command (MSC). On 14 February 1992, the Secretary of Defense signed a directive giving USTRANSCOM control of its component commands in time of peace as well as war. The directive reassigned the common-user transportation assets of the Air Mobility Command, Military Traffic Management Command, and the Military Sealift Command from their respective services to USTRANSCOM. The individual services retain only service-unique or organic theater assigned assets. [Ref. 18:pp. 18-19]

2. Air Mobility Command

The Air Mobility Command (AMC) is the U.S. military's primary provider of rapid, flexible, and responsive airlift. A component command of USTRANSCOM, AMC's missions include: airlift support, air combat camera services, operational support airlift, and aeromedical evacuation. AMC is additionally responsible for the management of the Civil Reserve Air Fleet (CRAF). The CRAF, which is composed of commercial aircraft, is committed in times of national

emergency to support the transportation of military forces and material worldwide. [Ref. 19:pp. 20-21]

3. Military Traffic Management Command

The Military Traffic Management Command (MTMC) is the Department of Defense's global traffic manager responsible for acquiring the appropriate commercial transportation services for the movement of freight, personal property, and passengers to ensure rapid and timely movement in the continental United States (CONUS) and through most overseas ports. As DoD's traffic manager, MTMC provides the interface between DoD shippers and the civilian transportation industry, and is the sole worldwide negotiator with commercial carriers for rates, terms and conditions for a majority of DoD transportation requirements. In addition to providing this interface with commercial carriers, MTMC also provides an interface with military shippers and the Air Mobility Command (AMC), and the Military Sealift Command (MSC). [Ref. 20:p. 47]

In relation to DoD's EDI implementation efforts in Defense Transportation, MTMC has been designated as the EDI Management Office for Defense Transportation.

4. Military Sealift Command

The Military Sealift Command (MSC) is the single operating agency and principal manager for Department of Defense ocean transportation. The primary mission of MSC is to provide sealift for strategic mobility in support of

national security objectives. In addition, MSC is tasked with direct fleet support and special mission support. In fulfilling these missions MSC operates a fleet of government owned and chartered U.S. flagships. This fleet includes fast sealift ships, maritime prepositioning ships, afloat prepositioning ships, ships of the Ready Reserve Force (RRF), as well as ships from the Naval Fleet Auxiliary Force (NFAF) and Special Mission Support Force assets. [Ref. 21:p. 22]

B. SYSTEMS APPROACH: TRANSACTION SETS AND APPLICATION PROCESSES

As discussed in Chapter V, the Department of Defense is committed to the implementation of electronic data interchange (EDI) as a means to improve economies and efficiencies in conducting business operations. One of the four functional areas identified by DMRD 941 as having the potential for significant savings and efficiency improvements resulting from the application of this technology was that of defense transportation. The purpose of an EDI system is to electronically link trading partners. In DoD's EDI program for defense transportation, the trading partners include DoD shipping activities, the Military Traffic Management Command (MTMC), DoD finance centers, the General Services Administration (GSA), and commercial carriers. These communication linkages allow the exchange of business data

such as tender/rate submissions, shipment information, and invoices. [Ref. 22:p. 3]

DoD's implementation of EDI in defense transportation involves a systems approach which integrates several individual elements. These elements consist of individual transaction sets and the specific functional areas, or as addressed here, application processes to which they are applied, facilitating the electronic exchange information.

1. Transaction Sets

In an EDI environment it is through the use of transaction sets that information is electronically exchanged. Transaction sets provide the basis for defense transportation EDI implementation efforts by providing the required foundation for all EDI transactions. Current DoD transportation EDI capabilities are limited to the following ANSI ASC X12 transaction sets¹⁰: [Ref. 23: Annex 1 - page 1]

- 110 - Air Freight Details and Invoice - X12.101. This transaction set is used by air freight carriers to submit information to DoD finance centers. This information relates to charges, discounts, and other details concerning the transportation services provided.
- 210 - Motor Carrier Freight Details and Invoice - X12.104. This transaction set is used by motor carriers to submit information to DoD finance centers. This information relates to charges, discounts, and other details relating to the transportation services which the carrier provided.

¹⁰ The format for these entries is: transaction set number, transaction set name, followed by the ASC X12 standard number.

- 214 - Motor Carrier Shipment Status Message - X12.106. Carriers use this transaction set to transmit shipment status information to applicable DoD shipping activities.
- 410 - Rail Carrier Freight Details and Invoice - X12.139. This transaction set is used by rail carriers to submit information to DoD finance centers. This information relates to charges, discounts, and other details on the transportation services which the carrier provided.
- 602 - Transportation Services Tender - X12.126. Carriers use this transaction set to submit rates and tender information to MTMC. These submissions include transmitting new tenders or amendments to existing tenders to MTMC.
- 858 - Shipment Information - X12.18. This transaction set is used by DoD to transmit detailed shipment information. The data sent using this transaction set are found on the *U.S. Government Bill of Lading*, Standard Form 1103.
- 859 - Freight Invoice - X12.55. This is a generic invoice used to transmit information relating to charges, discounts, and other details on the transportation services which the carrier provided. Although carriers may use any of the mode specific invoice transaction sets (110, 210, or 410), DoD is encouraging the use of the 859 transaction set.
- 994 - Administrative Message¹¹. DoD uses this transaction set to provide freight carriers with information concerning the acceptance or rejection of tenders which they have submitted. For the acceptance or rejection notification for personal property carriers, transaction set 997 is used.
- 997 - Functional Acknowledgment - X12.20. This transaction set is used to indicate if an EDI transmission is a valid ASC X12 transaction or not. Validity refers only to the transaction set's compliance with standard syntax requirements. Additionally, this transaction set is used to transmit notification of tender acceptance or rejection to personal property carriers.

¹¹ Transaction Set 994, Administrative Message, is a Transportation Data Coordinating Committee (TDCC) standard.

2. Application Processes

The DoD's operating concept for electronically linking its shipping activities, DoD finance centers, MTMC, GSA, and commercial carrier trading partners involves primarily four processes:

- Tender Submittal/Acceptance
- Shipment Information (Government Bill of Lading) Generation and Distribution
- Prepayment Auditing and Payment
- Postpayment Auditing

These processes form the foundation for electronically exchanging transportation related information and are critical elements for Defense transportation EDI initiatives.

Before discussing the four primary application processes, it is necessary to comment on DoD finance centers. Currently there are three DoD transportation payment centers: 1) Defense Finance and Accounting Service, Indianapolis Center (DFAS-IN), which processes and pays transportation bills for the Army, Air Force, and DLA; 2) the Marine Corp's Transportation Voucher Certification Branch (TVCB), Albany, responsible for Marine Corps transportation payment; and 3) the Navy Material Transportation Office (NAVMTO), Norfolk, responsible for processing and paying Navy transportation bills. Although all three of these payment centers are currently paying transportation bills for their respective service, DFAS-IN is instrumental to DoD operating in an EDI

environment. The eventual plan for the defense transportation EDI operating environment includes the consolidation of all transportation related payment functions at DFAS-IN. This initiative will be further addressed in the Future/Proposed Enhancements section of this chapter under the discussion of the Defense Transportation Payment System (DTRS¹²). [Ref. 24:p. 3]

a. Tender Submittal/Acceptance

The *Department of Defense Standard Tender of Freight Services* (MT Form 364-R) is used by commercial carriers to submit rates, under which they propose to move DoD cargo, to MTMC. Once received by MTMC, the information provided by the tender is used for transportation pricing, carrier selection, auditing, and payment.

MTMC's paper-based standard tender document processing operation typically involves the daily receipt of nine copies each of up to 100 paper tenders. Each tender must be reviewed for accuracy and then distributed to MTMC's Area Commands and the General Services Administration. This process involves numerous handling operations and repeated data entry into multiple computer systems. [Ref. 25:p. 1-1]

¹² According to the Transportation Operations Directorate, Systems Management Office (DFAS-IN-TA), of the Defense Finance and Accounting Service-Indianapolis Center, DTRS is used as the acronym for the Defense Transportation Payment System because the acronym DTPS was used for another system.

In submitting tenders electronically to MTMC, the carrier submits their proposed tender using the ASC X12 transaction set 602—Transportation Services Tender. Once received, MTMC's computers analyze the tender for conformance to established tender rules and regulations. If the tender satisfies this check it is accepted and a tender acceptance message is automatically transmitted to the carrier, using transaction set 994—Administrative Message for freight carriers, and transaction set 997—Functional Acknowledgment for personal property carriers. Once received and accepted, the tenders are distributed to GSA for use in postpayment auditing. Transaction set 994 (and 997 where appropriate) is also used if the tender is rejected, and will include the reason for rejection. [Ref. 25:p. 1-2]

Currently, carrier submission of electronic tenders is limited to voluntary tenders; guaranteed traffic and other negotiated tenders must continue to be submitted in paper format. As of January 1994, 44 carriers were electronically submitting 35 percent of all voluntary tenders filed with MTMC. [Ref. 26]. At present, electronic tender submission is also limited to motor and rail carriers, with other transportation modes to be added in the future [Ref. 27:p. 20].

The major benefit derived from electronic tender submission is the decrease in time required for the tender acceptance process. When submitting paper tenders, a carrier

may have to wait two to three weeks for approval. With EDI and electronic submission, the turnaround time is reduced to 48 hours. [Ref. 27:p. 20]

b. Shipment Information

The Government Bill of Lading (GBL) is the primary document used by the Department of Defense for procuring transportation services. Two types of GBLs are used by DoD, freight and personal property, with DoD shippers generating approximately 1.5 million freight and 800 thousand personal property GBLs annually. Since the GBL is a seven part form, this can result in over 45,000 pieces of paper a day being distributed among carriers, MTMC, and receivers (consignees). The utilization of EDI drastically reduces this volume of paper and the associated manual processing. [Ref. 28:p. 1-2]

In an EDI operating environment, a DoD shipping activity uses an automated system to generate a GBL. Once generated, the shipping activity transmits the shipment information to the carrier, all consignees, and MTMC using the ASC X12 transaction set 858, Shipment Information. Even with these electronic exchanges, paper is still required. Serving as an intransit manifest and as proof of service for payment, the original paper GBL will be given to the commercial carrier's driver, with a signed paper copy of the GBL being retained by the shipping activity. [Ref. 22:p. 6]

c. Prepayment Auditing and Payment

One of the recipients of the electronically transmitted shipment information is MTMC. Upon receipt of this information, MTMC verifies that a valid tender exists for the carrier. If a tender does not exist, MTMC rejects the shipment and notifies the originating DoD shipping activity. If a valid tender exists, MTMC creates an electronic record of the shipment and transmits rated shipment information to the Defense Finance and Accounting Service, Indianapolis Center (DFAS-IN) using transaction set 858, Shipment Information. [Ref. 30:p. 2]

Following delivery, the commercial carrier submits invoices electronically to DFAS-IN using transaction sets 110, 210, 410, or 859, which are the Air Freight Details and Invoice, Motor Carrier Freight Details and Invoice, Rail Carrier Freight Details and Invoice, and the Freight Invoice respectively. Prior to payment DFAS-IN audits the invoice by matching rated shipment information with the appropriate invoice and reconciling any differences. [Ref. 22:p. 6]

Following the audit and reconciliation process, DFAS-IN pays the carrier for the services performed. The actual amount paid is the lesser of the amount on the shipment information record or on the invoice. Lastly, DFAS-IN completes the record for the shipment by sending payment information to MTMC and also sending invoice, payment, and

shipment information to the General Services Administration for postpayment auditing.

d. Postpayment Auditing

Upon receipt of invoice, payment, and shipment information from DFAS-IN, the General Services Administration performs postpayment auditing. In performing the postpayment audit, GSA also uses the accepted tender submission which it had previously received from MTMC. [Ref. 31]

C. DEFENSE TRANSPORTATION EDI OPERATING CONCEPT

Through the electronic exchange of information among shipping activities, commercial carriers, the Military Traffic Management Command, Defense Finance and Accounting Service - Indianapolis Center, and the General Services Administration, DoD hopes to achieve increased economies and efficiencies in defense transportation operations. The realization of this goal involves the successful integration of the previously discussed application processes. The comprehensive nature of DoD's approach to the implementation of EDI in defense transportation is summarized in two predominant operating concepts:

- Defense Transportation EDI Operating Concept: Freight [Ref. 22:p. 5]
- Defense Transportation EDI Operating Concept: Personal Property [Ref. 32:p. 1-3]

Though conceptually similar, the operating concepts applicable to freight and personal property are discussed separately. To help clarify the discussion of these EDI operating concepts, Figure 20 depicts the data flow format conventions that are used in the accompanying figures highlighting the data flow identification numbers and EDI transaction sets. For example in Figure 20, the first data flow shows the carrier submitting tenders to MTMC using transaction set 602. This is followed by data flow number two, which is MTMC's tender acceptance/rejection and is transmitted using transaction set 994.

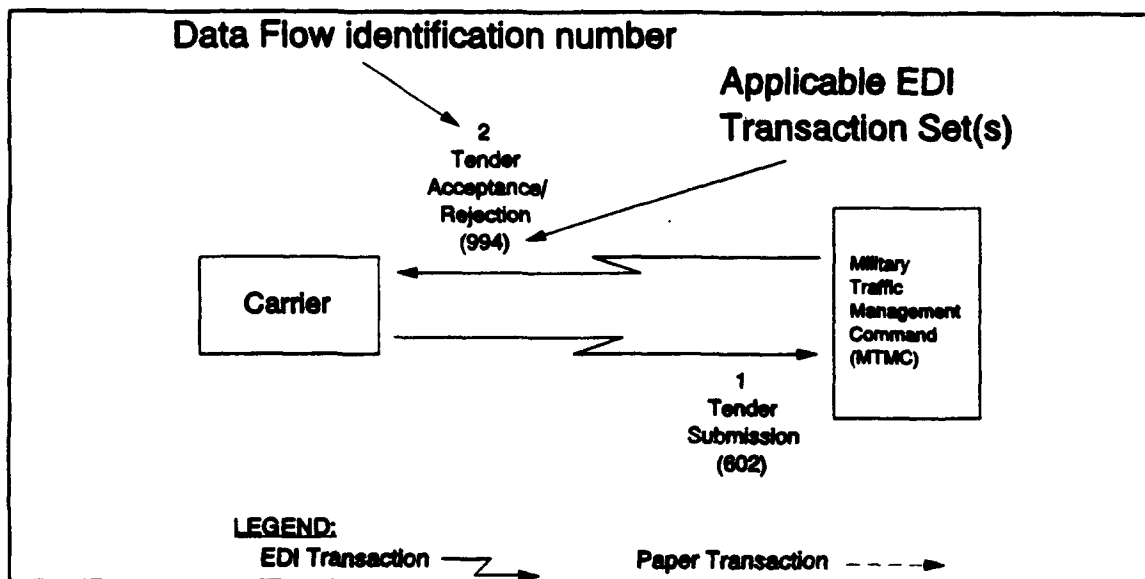

Figure 20 Operating concept data flow format convention

1. Defense Transportation EDI Operating Concept: Freight

The Department of Defense's EDI operating concept for electronically linking freight carriers, MTMC, Defense

shipping activities, DFAS-IN, and GSA is depicted in Figure 21. This operating concept depicts an overall systems approach to integrating the rate and tender submittal, shipment information, prepayment audit and payment, and postpayment audit application processes.

a. CONUS Freight Management System

An integral component of DoD's freight EDI operating concept is MTMC's CONUS Freight Management (CFM) system. The CONUS Freight Management system is DoD's centralized automated freight traffic management system for domestic freight movement. As the centralized information management system, CFM performs six primary functions: 1) routing of domestic freight shipments, 2) supporting prepayment audits of GBLs, 3) providing rate-quoting services, 4) monitoring commercial freight carrier performance, 5) monitoring the overall efficiency of the domestic freight traffic system, and 6) supporting the Joint deployment community during contingencies [Ref. 33:pp. 2-5 - 2-7].

The CFM system data base contains rate and shipment information derived from the *U.S. Government Bill of Lading* (GBL) (Standard Form 1103) and the *Department of Defense (DoD) Standard Tender of Freight Services* (MT Form 364-R). The CFM system has the capability to receive this data from three sources: 1) CFM field modules (currently 53 shipping activities are on-line); 2) shipper services interfacing

Figure 21 Defense Transportation EDI Operating Concept:
Freight

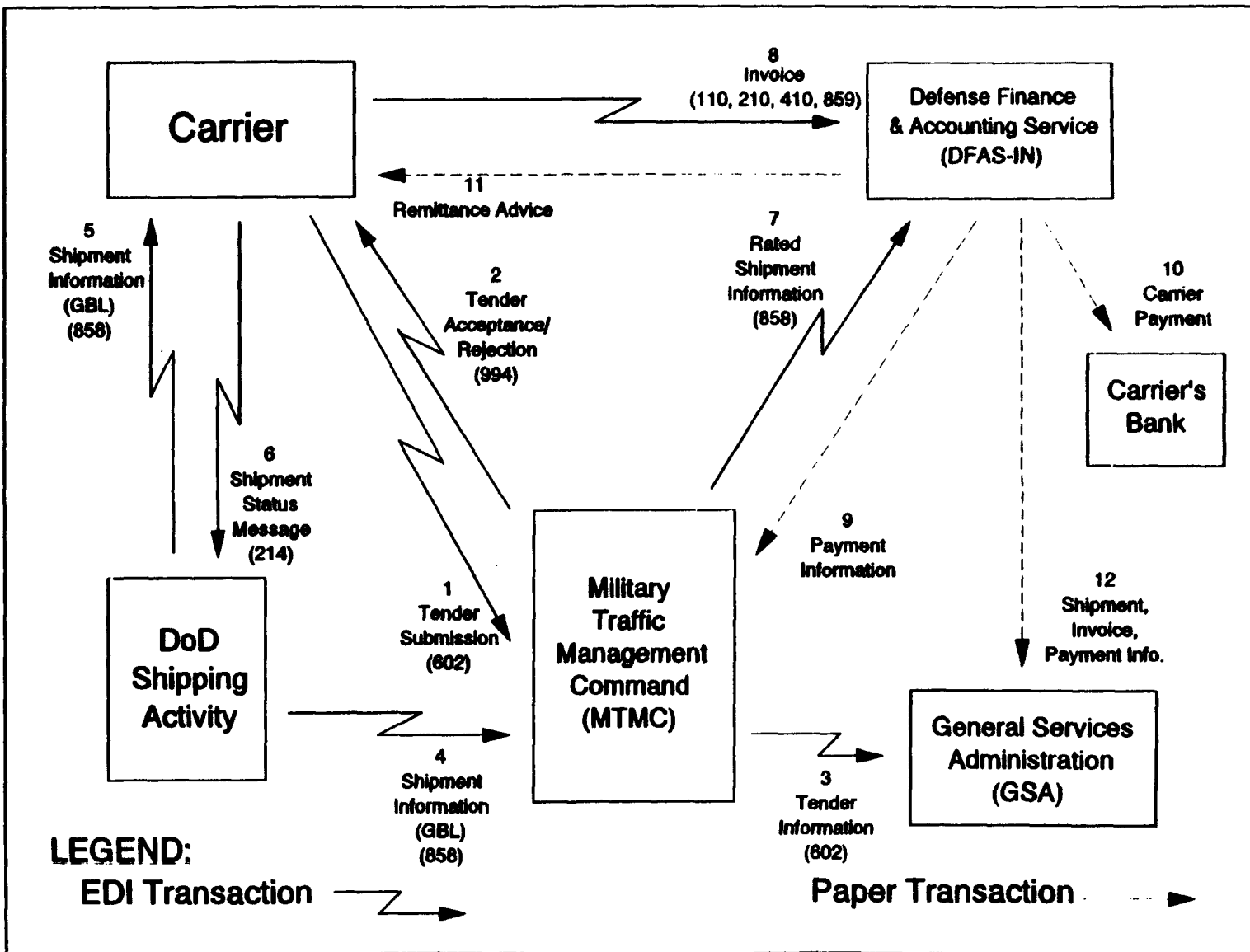

systems¹³; and 3) the Defense Transportation Payment System (DTRS). [Ref. 34:pp. 14-15]

The CFM system provides the information data base necessary for establishing an effective EDI operating environment for DoD freight transportation operations. It is the application of EDI that allows MTMC (CFM) to electronically transmit rate and payment data among freight carriers, DoD shippers, and DFAS-IN.

b. Freight Operating Concept Data Flows

Descriptions of the data flows associated with the DoD EDI freight operating concept depicted in Figure 21 follow: [Ref. 22:pp. 5-7]

- Data Flow 1: A commercial carrier submits electronic tenders (proposed rates) for transportation services to the Military Traffic Management Command (MTMC).
- Data Flow 2: Upon receipt of the electronic tenders, MTMC's computers analyze the tenders for accuracy and conformance to established rules and regulations. After this review MTMC will transmit a tender acceptance or rejection message to the submitting carrier.
- Data Flow 3: Accepted tenders are electronically transmitted to the General Services Administration (GSA).
- Data Flow 4: DoD shipping activities, which create the GBL, transmit the shipment information contained on the GBL to MTMC.

¹³ CFM shipper services interfacing systems include: Cargo Movement Operations System (CMOS), Defense Transportation Tracking System (DTTS), Integrated Booking System (IBS), Transportation Management system (TMS), Worldwide Port System (WPS), and the Global Transportation Network (GTN).

- Data Flow 5: DoD shipping activities, which create the GBL, transmit the shipment information contained on the GBL to the applicable freight carrier (if desired).
- Data Flow 6: DoD shipping activities have the capability to electronically receive shipment status information from the carrier.
- Data Flow 7: Using the received and accepted tenders, MTMC provides rated shipment information to DFAS-IN.
- Data Flow 8: After delivery of the freight, the carrier transmits the appropriate invoice to DFAS-IN.
- Data Flow 9: Upon receipt of the invoice, DFAS-IN performs a prepayment audit, matching rated shipment information with the appropriate invoice. Once complete, DFAS-IN provides MTMC with the cost information, which completes the shipment record.
- Data Flow 10: The DoD process for paying freight carriers for transportation services is currently a manual process.
- Data Flow 11: After payment, DFAS-IN provides payment information (often referred to as remittance advice) to the freight carrier. This transaction includes such information as notification of payment, payment amount and the applicable invoice for which payment is being made.
- Data Flow 12: Lastly, DFAS-IN provides payment information to GSA for postpayment audit.

2. Defense Transportation EDI Operating Concept: Personal Property

When applied to the transportation aspects of DoD's personal property program, the EDI operating concept involves electronically linking personal property carriers, MTMC, Defense shipping activities, DFAS-IN, and GSA. As with the freight EDI operating concept, EDI in the personal property environment consists of the integration of the rate and tender

submittal, shipment information, prepayment audit and payment, and postpayment audit application processes.

In developing the personal property EDI operating concept, EDI technology was applied to the Military Traffic Management Command's Transportation Operational Personal Property Standard System (TOPS) and the Worldwide Household Goods Information System For Transportation (WHIST). These automated management information systems provide the information base for establishing an effective EDI operating environment for personal property transportation operations.

[Ref. 32:pp. 1-2 - 1-3]

a. Transportation Operational Personal Property Standard System

The Transportation Operational Personal Property Standard System (TOPS) is a DoD-wide information management system which automates operations at the Personal Property Shipping Office (PPSO) level. TOPS was developed to assist Personal Property Shipping Offices by eliminating the extensive manual processing of personal property shipment information. This system automates the gathering, exchange, and maintenance of personal property information for outbound and inbound personal property shipments. In addition to capturing and processing personal property data, TOPS is the information distribution link between personal property

offices and the Worldwide Household Goods Information System For Transportation (WHIST). [Ref. 35:pp. 10-13]

b. Worldwide Household Goods Information System for Transportation

The Worldwide Household Goods Information System for Transportation (WHIST) is DoD's central personal property transportation data base. The purpose of WHIST is to collect, process, and maintain carrier-filed rate as well as shipment information supplied by TOPS. WHIST provides shipment transportation and rate information to DFAS-IN and to other DoD activities to support their personal property information requirements. [Ref. 36:pp. 1-1 - 1-2]

c. Personal Property Operating Concept Data Flows

As depicted in Figure 22, the TOPS and WHIST systems perform vital functions involving the capturing, processing, and distribution of business information necessary to initiate, monitor, and manage DoD's personal property shipment system. A description of the requisite data flows associated with this operating concept is as follows: [Ref. 37]

- Data Flow 1: A personal property carrier submits electronic tenders (proposed rates) for transportation services to WHIST in response to a Military Traffic Management Command (MTMC) solicitation.
- Data Flow 2: Upon receipt of the electronic tenders, MTMC's computers analyze the tenders for accuracy and conformance to established rules and regulations. After this review MTMC will transmit a tender acceptance or rejection message to the submitting carrier. Where the

Figure 22 Defense Transportation EDI Operating Concept:
Personal Property

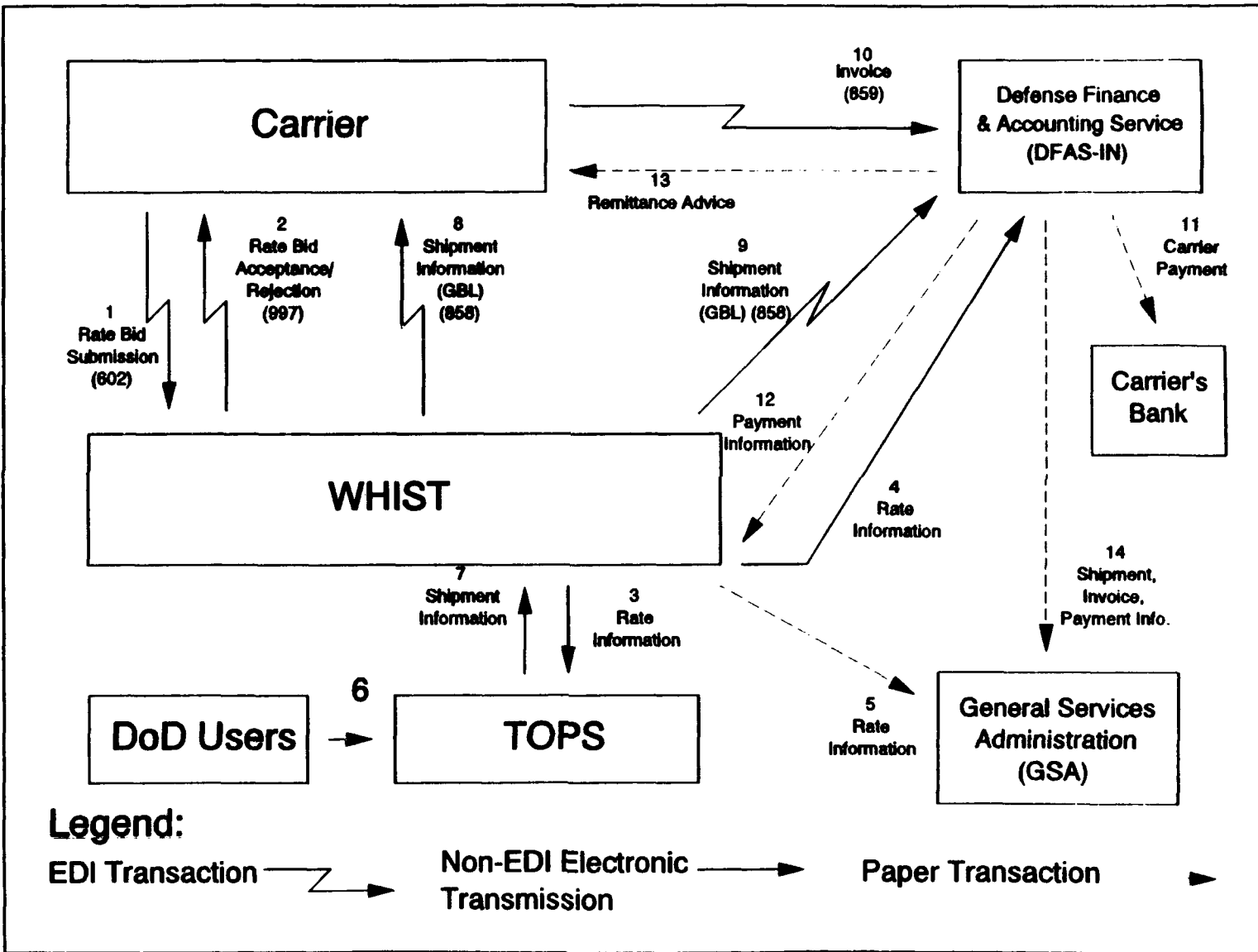

freight EDI operating concept utilized transaction set 994—Administrative Message to convey acceptance or rejection of tenders, here transaction set 997—Functional Acknowledgment is used.

- Data Flow 3: The WHIST data base provides rate information to TOPS. This electronic transmission is accomplished through the use of a wide area network (WAN).
- Data Flow 4: The WHIST data base also provides rate information to DFAS-IN through the electronic transmission of a flat file.
- Data Flow 5: In addition to providing rate information to TOPS and DFAS-IN, WHIST also provides this information to GSA. The conveyance of rate information to GSA is accomplished through paper means.
- Data Flow 6: This data flow depicts the initial interface between a DoD shipper of personal property and the personal property movement system. To initiate the shipment, the DoD customer interfaces with the personal property system through TOPS at the appropriate PPSO.
- Data Flow 7: TOPS gathers the shipment information from the DoD user and transmits the information to WHIST. As was the case with the transmission of rate information between TOPS and WHIST, this data flow is electronic with the information using a WAN instead of EDI.
- Data Flow 8 and 9: WHIST, which creates the GBL using the information provided by TOPS, transmits shipment information to the applicable personal property carrier and to DFAS-IN.
- Data Flow 10: After delivery of the shipment to storage or a residence, the carrier receives shipment information from WHIST for use in generating the invoice. The carrier then transmits the appropriate invoice to DFAS-IN for payment.
- Data Flow 11: Upon receipt of the invoice, DFAS-IN performs a prepayment audit, matching rated shipment information with the appropriate invoice. Once complete, DFAS-IN pays the carrier. As with payment for freight carriers, DoD's process for paying personal property carriers is currently a manual process.
- Data Flow 12: DFAS-IN provides WHIST with cost information, currently provided using paper as the medium of exchange, which completes the shipment record.

- Data Flow 13: After payment, DFAS-IN provides payment information (often referred to as remittance advice) to the personal property carrier. This transaction includes such information as notification of payment, payment amount and the applicable invoice for which payment is being made.
- Data Flow 14: Lastly, DFAS-IN provides payment information to GSA for postpayment audit.

3. Future/Proposed Enhancements

The preceding discussion of the DoD EDI operating concepts for defense transportation primarily involved the current status of these initiatives. DoD's commitment to EDI is long-term and the EDI operating environment is continually evolving. Four of the principal future enhancements for defense transportation include:

- Defense Transportation Payment System
- Electronic Funds Transfer
- Transaction Set 820, Payment Order/Remittance Advice
- Electronic Submission of Guaranteed Traffic Tenders

a. Defense Transportation Payment System (DTRS)

The defense transportation EDI operating concept involves the implementation of electronic data interchange to the maximum extent possible. As depicted in Figures 21 and 22, the prepayment auditing and carrier payment processes still involve labor intensive manual processing. Each year approximately 85 percent (1.1 million) of the 1.3 million annual total DoD CONUS freight shipments are transported by

motor carriers, 12.5 percent (0.2 million) by air freight carriers, 1.5 percent (20,000) by rail carriers, and less than 1 percent by others. DLA is the principal DoD shipper accounting for 45 percent¹⁴ of the total. DLA is followed by the Army with 24 percent, the Air Force with 17 percent, the Navy with 12 percent, and the Marine Corps with 2 percent.

[Ref. 33:pp. 3-3 - 3-4]

The Defense Finance and Accounting Service - Indianapolis Center (DFAS-IN), is DoD's largest transportation payment center, annually processing over a million freight, personal property, and travel-related bills for the Army, Air Force, and Defense Logistics Agency. The existing prepayment auditing and payment processes are labor intensive and involve time consuming manual handling of shipment information documents. To eliminate the costs and inefficiencies associated with the existing system, DoD is in the process of implementing the Defense Transportation Payment System (DTRS) at DFAS-IN.

The Defense Transportation Payment System is an initiative which will use EDI technology in a paperless environment, enhancing the transportation payment, collection, accounting, and reporting functions. The DTRS concept will allow DFAS-IN: [Ref. 38:p. 1]

¹⁴ This total includes the Defense Contract Administration Service shipping (DCAS). The actual breakdown between is that DLA accounts for 34 percent with DCAS accounting for 11 percent. [Ref. 33:pp. 3-3 - 3-4]

- To electronically receive government bills of lading (GBLs) and shipment cost data from EDI-capable shipping activities.
- To receive electronic invoice information from EDI-capable carriers.
- To pay carriers through electronic funds transfer (EFT).
- To consolidate all DoD transportation payment functions at DFAS-IN.

The Defense Transportation Payment System is a long term initiative which will be implemented in four increments:

[Ref. 39: chart 2]

- Increment I: The focus of Increment I includes: 1) automating the receipt of invoices and shipment information, 2) automating the processing of payments, 3) interfacing electronically with GSA, MTMC, and carriers.
- Increment II: Increment II addresses the automation of claims processing and the integration of claim, invoice, payment, and collection functions.
- Increment III: In Increment III, DTRS will implement the capability to process shipment information, invoices, and payments for personal property shipments. Additionally, increment III will result in DTRS interfacing with the Standard Disbursing and Accounting System, automating fund disbursement, and implementing electronic fund transfer (EFT) technology to transmit payments to carriers.
- Increment IV: Navy and Marine Corps transportation payment requirements will be consolidated at DFAS-IN during Increment IV.

The Defense Finance and Accounting Service-Indianapolis Center is continuing with the implementation of increment I of the DTRS initiative. Currently DFAS-IN is limited to the receipt and processing of guaranteed traffic shipment information associated with the Defense Logistics

Agency (DLA) Defense Distribution Depot at Ogden, Utah. The next two shipping activities planned to be linked with DFAS-IN will be the Defense Construction Supply Center, Columbus, Ohio and the Defense Depot located in Memphis, Tennessee. Other milestones for the implementation of DTRS include a FY 94 target for capability to exchange electronic transactions with personal property carriers, and to have all the transportation payment functions consolidated at DFAS-IN (increment IV) during FY 95. [Ref. 40]

b. Electronic Funds Transfer

Electronic Funds Transfer (EFT) is "...the electronic transfer of value, meaning the debiting of one account and the crediting of another" [Ref. 2:p. 217]. As applied to DoD transactions, EFT includes the actual payment (transfer of value) as well as the exchange of payment and remittance information.

The concept and use of electronic funds transfer is not new to the Department of Defense. DoD has for many years used EFT to deposit pay and benefits directly into individual bank accounts, resulting in an increase in productivity of personnel and a reduction in the cost of correcting errors and replacing lost checks. However, paying transportation vendors is a new EFT application for the DoD. [Ref. 41:p. 1-1]

As mentioned above, DoD implementation of EFT for defense transportation is included in the DTRS Increment III.

c. Transaction Set 820, Payment Order/Remittance Advice

Currently the transportation payment centers (DFAS-IN) do not have the capability to utilize the 820 transaction set. As suggested in both the freight and personal property EDI operating concepts, when the operational capability exists, transaction set 820 will be used by DFAS-IN to transmit payment information, also referred to as remittance advice, to MTMC, the carrier, and to GSA. These transmissions will indicate that payment for an invoice has been made, the amount of the payment, the purpose of the payment, and any additional information relating to the adjustment of the invoiced amount.

d. Electronic Submission of Guaranteed Traffic Tenders

Another planned future enhancement to DoD's EDI transportation operating concept is the capability for receiving the electronic submission of tenders for guaranteed traffic. As previously discussed, at present carriers are limited to the electronic submission of voluntary tenders. In contrast to these voluntary submissions, MTMC's Inland Traffic Negotiations Division (MT-INN) solicits tenders from carriers to meet specific movement requirements. These solicitations are made through the guaranteed traffic (GT) program and

currently account for over 40 percent of Defense shipments.

[Ref. 42:p. 1-1]

The current, labor-intensive, time consuming manual methods for processing guaranteed traffic solicitations and tenders involves four distinct steps: 1) a DoD shipper submits a traffic movement requirement to MT-INN, who then develops a solicitation to satisfy the requirement (presolicitation phase); 2) MT-INN advertises the solicitation and receives proposed rates from carriers in the form of tender bids (solicitation phase); 3) after receipt of the tender bids, MT-INN conducts an evaluation to determine the carriers offering the lowest cost rates (evaluation phase); 4) lastly, MT-INN will award the traffic to the carrier offering the lowest cost rates, and will publish and distribute those rates as GT tenders (award phase). [Ref. 42:p. 2-2]

As with other labor intensive document processing, the GT program has the potential for significant improvements in economies and efficiencies if the manual procedures can be replaced by electronic processing. The application of EDI to the GT program is currently undergoing test and evaluation¹⁵.

¹⁵ For further details on the proposed electronic submission of guaranteed traffic tenders see "An Electronic Commerce Strategy for MTMC's Guaranteed Traffic Program," Logistics Management Institute, Report MT901R1, October 1992.

D. ADDITIONAL DEFENSE TRANSPORTATION ELECTRONIC DATA INTERCHANGE INITIATIVES

In addition to the specific EDI projects which are an integral part of the overall Defense transportation EDI operating concept (e.g., CFM, TOPS, and WHIST), there are numerous other initiatives underway. These efforts include projects designed to interface with the freight and personal property EDI operating concepts as well as those which are more service-specific in nature. Discussed below are some of the principal efforts currently being undertaken.

1. Cargo Movement Operations System

The Cargo Movement Operations System (CMOS) is the Air Force's response to the 1987 Joint Chiefs of Staff (JCS) requirement for the Transportation Coordinators' Automated Information Movement System (TCAIMS)¹⁶. CMOS automates base-level transportation processes focussing on achieving greater efficiency in operations as well as providing In-Transit Visibility (ITV) of cargo and unit passenger movements. Current CMOS capabilities include: 1) automation of all air and surface freight operations, 2) advance shipping notice to other CMOS sites, 3) automated financial accounting, 4) standardized transportation information processing, and 5) interfaces with the CONUS Freight Management system. [Ref. 43]

¹⁶ TCAIMS is a generic term for the hardware, software, procedures, and related systems that provide integration of the movement information used in the force deployment process.

2. Advanced Arrival Notification Interface

Currently in the development stage, the Advance Arrival Notification Interface is an Army system which will allow MTMC ports to receive import arrival notifications from ocean carriers and cargo release notification from customs. The primary transaction set involved with this transmission of information is transaction set 312, Arrival Notice for Ocean Carriers. [Ref. 44]

3. Worldwide Port System

An Army system, the Worldwide Port System (WPS) is an automated information management system designed to enhance MTMC's terminal management and cargo documentation mission. The predominant role of WPS is to support the peacetime and wartime tracking and documenting of DoD cargo moving via common user ocean transportation, while maintaining in-transit visibility. [Ref. 45:pp. 18-19]

4. Transportation Discrepancy Report

The automation of the Transportation Discrepancy Report (TDR) is a MTMC program designed to allow consignees to record discrepancies and transfer the data electronically to the CFM host system. Upon receipt, the CFM host will distribute the electronic TDR in EDI format to the appropriate claims offices of the military services, to the shipper, DoD finance center, and the carrier. The TDR effort will utilize

transaction set 842, Nonconformance Report, and at present is in the late development phase. [Ref. 46]

5. Transportation Management System

The Transportation Management System (TMS) is a system developed by the Marine Corps and adopted by the Navy for automating the GBL process. The Marine Corps developed the system as part of the Office of the Secretary of Defense (OSD) sponsored project for GBL automation. TMS automates the generation of GBLs and translates the information to the required EDI format for transmission using transaction set 858, Shipment Information (e.g., to MTMC and the Navy Material Transportation Office (NAVMTO)). In addition, TMS is capable of receiving EDI transactions for inbound GBLs and invoices, automatically validates invoices against the original GBL, and transfers payment information to the transportation payment center. [Ref. 47:p. 3-11] and [Ref. 48]

6. Transportation Operation Management

The Transportation Operation Management (TOM) system is a Navy-proposed system, currently in the development stage, designed to improve NAVMTO management of transportation operations. The TOM system will be an integrated information system whose data base will support in-transit visibility, cargo routing, and movement authorization for all Navy shipments. The TOM system will exchange information using transaction sets 214 (Shipment Status Message), 856 (Ship

Notice/Manifest), and 858 (Shipment Information). [Ref. 49:p. 3-6]

7. Do-It-Yourself EDI Automated Loading System

The Do-It-Yourself EDI Automated Loading System (DEALS) is a Navy-sponsored program planned to replace the current system which supports Do-It-Yourself (DITY) moves of household goods. DEALS will automate the *Application for DITY Move and Counseling Checklist* (DD Form 2278), *Application for Non-Temporary Storage* (DD Form 1164), and *Travel Voucher* (DD Form 1351-2) and then transmit this information electronically to NAVMTO using transaction set 858, Shipment Information. [Ref. 49:pp. 3-6 - 3-7]

8. Household Goods EDI Audit Transactions

Another Navy project, the Household Goods EDI Audit Transactions (HEAT) project was developed to improve the auditing of household goods movements. Initially, HEAT focussed on automating the *Application for Shipment and/or Storage of Personal Property* (DD Form 1299), the document which authorizes personal property shipments and enables NAVMTO auditors to determine whether payments have been made for all shipments related to a particular member's relocation. The HEAT concept replaces the Personal Property Shipping Office's manual submission of DD Form 1299 with electronic transmission using transaction set 858, Shipment Information. [Ref. 49:p. 3-7]

9. Defense Transportation Tracking System

The Defense Transportation Tracking System (DTTS) data base is maintained at the Naval Material Transportation Office (NAVMTO) located in Norfolk, VA. Currently the system is in the test and development stage, with the capability of communication with the Red River Army Depot (the implementation plan is to have all applicable shippers on-line within one year). This system uses satellite technology to track and monitor shipments of arms, ammunition, and explosives transported throughout the Continental United States (CONUS) by commercial carriers. To establish the requisite data base record before satellite tracking can occur, carriers must submit shipment information to DTTS. The application of EDI technology to this system will allow for the electronic submission of shipment information using transaction set 856, Shipment Information. [Ref. 49:p. 3-6]

E. ASSOCIATED DEFENSE TRANSPORTATION ELECTRONIC DATA INTERCHANGE ISSUES

1. Telecommunications Architecture

Figure 23 depicts the defense transportation EDI telecommunications architecture. As shown, this communications infrastructure consists of three separate modes for connecting trading partners: 1) a value added network (VAN), 2) direct leased lines, or 3) the Defense Data Network (DDN) or the NAVSUP Logistics Network (NLN).

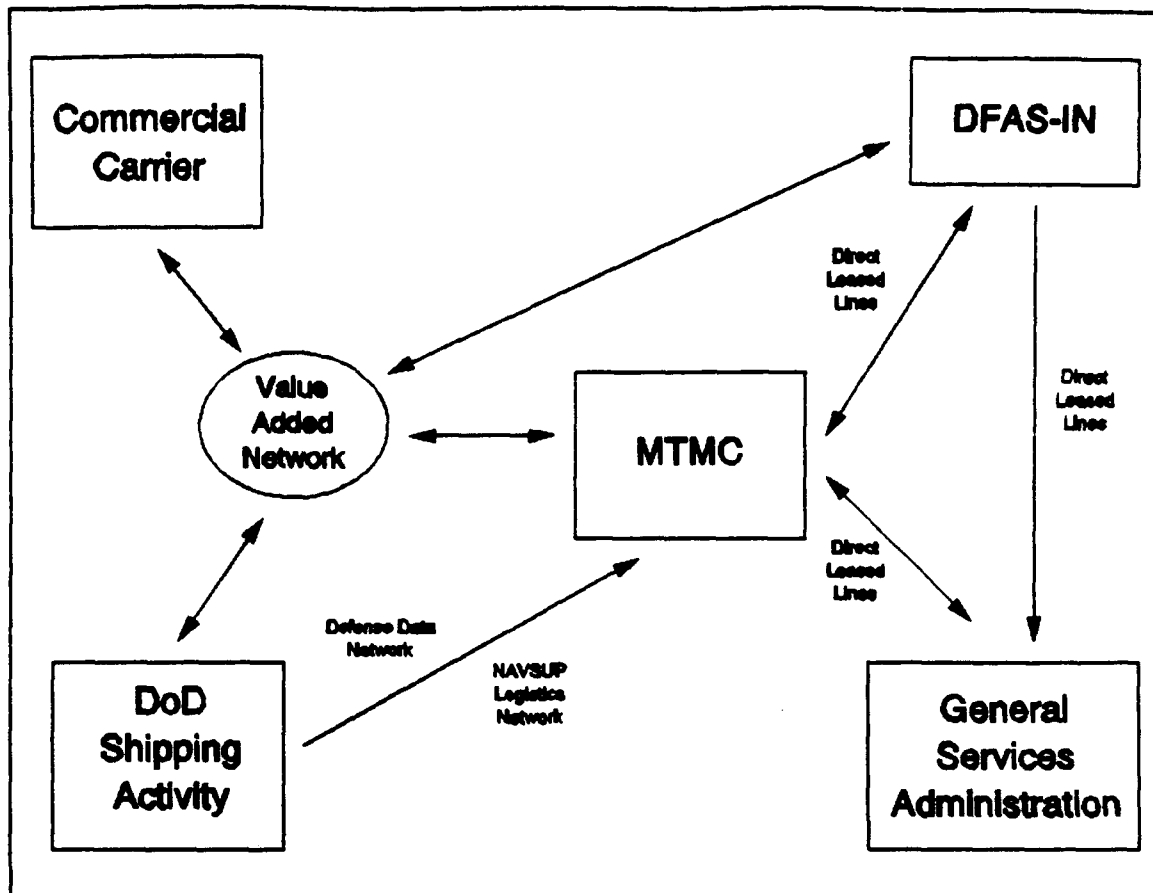

Figure 23 Defense transportation EDI telecommunications architecture

Value added network services for defense transportation are currently provided by Sprint¹⁷. Sprint is under contract with GSA as the official DoD transportation VAN to be used for EDI communications originating within DoD for transmission to non-DoD activities. While Sprint is the required VAN for DoD-originated transactions, DoD's commercial trading partners are free to use the VAN of their choosing as

¹⁷ While Sprint is the official DoD transportation VAN, MTMC is currently using AT&T EasyLink for some of their VAN requirements.

long as it has the capability to communicate with the EDI VAN used by DoD (currently Sprint).

Due to the high volume of information transmitted among MTMC, GSA, and DFAS-IN (current and planned volume), direct lines are leased from local telephone providers. For a majority of the remaining information traffic (intra-DoD), DDN is used to link the various Service, DLA, and MTMC sites to one another. The remaining mode, the NAVSUP Logistics Network, is used for EDI communications within the Navy.

2. Barriers to Defense Transportation Electronic Data Interchange Implementation

The implementation of electronic data interchange and the resulting transition to a paperless environment represents a significant change to the traditional way the Department of Defense conducts business. As is often the case with the introduction of new actions, methods and ideas, the application of EDI technology to defense transportation operations has, and is, experiencing resistance. In examining DoD's implementation of EDI to the processing of defense transportation information, four predominant instances of resistance (barriers) to the efficient implementation of electronic data interchange include:

- Lack of knowledge and/or understanding
- Decentralization of effort
- Cost-benefit analysis and resourcing

● Standardization

a. Lack of Knowledge and/or Understanding

When considering the implementation of EDI it is important to understand that electronic data interchange is a technology, a way of doing business, and not a specific system. As Michael Hammer discusses in "Reengineering Work: Don't Automate, Obliterate": [Ref. 50:pp. 104-112]

It is time to stop paving the cow paths. Instead of embedding outdated processes in silicon and software, we should obliterate them and start over. We should "reengineer" our businesses: use the power of modern information technology to radically redesign our business processes in order to achieve dramatic improvements in their performance.

Those involved with the application of EDI technology must realize that introducing EDI to obsolete and inefficient processes will not necessarily result in improved performance or increased efficiencies. The appropriate questions can no longer solely be "Can a particular process be adapted to EDI techniques?" and if yes, "How to go about it?", but must now include "Why are we doing business in the current manner?" and "In its present format, should EDI be applied to this process?"

b. Decentralization of Effort

Although EDI is a major DoD initiative, its development and implementation has been largely left up to the discretion of the individual services. This decentralized approach to implementation has resulted in: 1) varying levels

of importance placed on EDI among the services, 2) the sporadic fielding of EDI projects, 3) the uneven distribution of personnel with EDI expertise, and 4) in many cases, the duplication of effort among activities, and the resulting additional expenditure of scarce resources.

c. Cost-benefit Analysis and Resourcing

As available resources continue to diminish, there is greater competition for funding among DoD programs. As a result, it is becoming increasingly more difficult for individual programs to justify DoD commitment of resources in support of their efforts. One of the potential problems facing DoD EDI programs is the nature of the potential benefits. As reported in DMRD 941 it is expected that the indirect benefits of EDI implementation will be more significant than the direct benefits. A possible obstacle here is associated with the potential for subjectivity and the resulting difficulty in identifying what the actual (anticipated) indirect benefits are (will be). Additionally, many of the benefits associated with EDI implementation are intuitive and intangible in nature, making the quantification of any related cost savings more difficult. The potential difficulties in identifying and quantifying actual cost related savings resulting from EDI implementation may make it increasingly more difficult to obtain resources.

d. Standardization

The Department of Defense has mandated that activities shall use the ANSI ASC X12 standard for conducting EDI transactions. While this significantly improves the potential for the efficient exchange of information, the use of the X12 standard is only part of the solution. Once the individual transaction sets are identified, the corresponding data must be mapped to the appropriate EDI format. Coordinated efforts must continue between trading partners to standardize the data mapping along with the corresponding implementation convention to further ensure that EDI information exchange is optimized.

F. CHAPTER SUMMARY

This chapter has focused on the application of electronic data interchange to defense transportation operations. As discussed in Chapter V, transportation was one of the four functional areas identified by DMRD 941 as having the potential for significant savings and efficiency improvements resulting from the application of EDI technology. Through the electronic exchange of information among its trading partners¹⁸, DoD hopes to achieve increased economies and

¹⁸ The Department of Defense's trading partners for the electronic exchange of information pertaining to defense transportation operations include: DoD shipping activities, the Military Traffic Management Command (MTMC), the Defense Finance and Accounting Service, Indianapolis Center (DFAS-IN), the General Services Administration (GSA), and commercial carriers.

efficiencies in defense transportation operations. DoD's implementation of EDI in defense transportation involves a systems approach which integrates several functional area application processes as well as the individual transaction sets used for the actual electronic exchange of information. The comprehensive nature of DoD's approach to the implementation of EDI in defense transportation is summarized in two predominant operating concepts: 1) Defense Transportation EDI Operating Concept—Freight and 2) Defense Transportation EDI Operating Concept—Personal Property.

Reflecting DoD's long-term commitment to EDI, four of the principal future enhancements for defense transportation were discussed: 1) Defense Transportation Payment System, 2) Electronic Funds Transfer, 3) Transaction Set 820, Payment Order/Remittance Advice, and 4) Electronic Submission of Guaranteed Traffic Tenders.

In addition to the specific EDI projects which are an integral part of the overall Defense transportation EDI operating concept (e.g., CFM, TOPS, and WHIST), there are numerous other initiatives underway. These efforts include projects designed to interface with the freight and personal property EDI operating concepts as well as those which are more service specific in nature.

VII. SUMMARY AND CONCLUSIONS

A. SUMMARY

Communications and the exchange of information are critical elements for a majority of the activities in which organizations engage. Historically, organizations have typically relied exclusively on paper for conducting business transactions and exchanging information among business partners. Although proven to be effective and convenient, paper may no longer be the most efficient medium for conducting business transactions. Advances in computers, communication, and electronic technology have provided a variety of alternative information processing techniques, which allow information to be processed faster, more accurately, and at a lower cost than similar manual, paper-based, processing systems.

One such method is Electronic Data Interchange (EDI). Electronic data interchange is the inter-organizational, computer-to-computer exchange of business documentation and information in a standardized, machine-processable format. It is important to understand that EDI is a technology, a way of doing business, and not a specific system. The implementation of EDI involves more than just the automation of existing processes. Electronic data interchange provides the

opportunity to revise existing information handling methods which can result in improved performance, economies, and efficiencies in operations. The primary purpose of EDI is to make business processes more efficient by enhancing information management through the replacement of paper with electronic equivalents.

The computer-to-computer exchange of information is not new to American industry or to the Department of Defense. Since the 1960s, private companies and DoD activities have been exchanging business information electronically. A major characteristic, and drawback, of these early data exchange arrangements was the use of many different non-standard and proprietary data formats.

The development of standard data formats, also referred to as "standards," played an important role in the development and acceptance of EDI technology. Prior to the development of standardized formats, organizations may have needed different computer systems or applications for each customer, or trading partner, with which it wished to electronically communicate. Standardization eased the electronic exchange of data and encouraged the use of EDI technology by providing a uniform method for configuring unstructured data into a structured format. This structuring and standardization of data format allows computers to transfer, read, understand and process information automatically, without additional human intervention.

By providing a common language for the electronic exchange of information, the standards eliminate the need to develop special software for each trading partner's unique data format. This, in turn, allows the use of one software package to generate transactions in a format appropriate for the exchange of information between multiple trading partners.

When discussing EDI data format standards, keep in mind that:

- Compliance with the standards is strictly voluntary, decided among trading partners.
- The standards specify only the format, rules, and data content of electronic business transactions; they do not address how trading partners will establish the required physical communications link to exchange EDI data.

To take advantage of emerging electronic information technology capabilities, the Department of Defense has adopted the concept of Electronic Commerce (EC), the digital exchange of all information needed to conduct business. The objective of DoD's EC program is not to just automate existing manual processes, but to implement the necessary systems, capabilities, and procedures which will allow DoD activities to fundamentally alter and improve the manner in which they accomplish their business operations. Although EC encompasses a variety of electronic information processing technologies, the key to DoD changing its business practices from paper-based document processing to a total electronic environment is electronic data interchange.

Recognizing the potential of EDI, the Deputy Secretary of Defense, in May of 1988, issued a memorandum specifying that EDI was to "become the way of doing business" for the Department of Defense. Specifically, Deputy Secretary Taft directed that: [Ref. 15]

Consistent with our commitments to improve productivity and move toward a paperless environment, all DoD components should make maximum use of electronic data interchange (EDI) for the paperless processing of all business-related transactions.

The American National Standards Institute X12 uniform standards for inter-industry electronic interchange of business transactions will be employed as the standard for EDI, providing a common approach to implementation and a single, coordinated DoD position to industry.

The Department of Defense's commitment to EDI was further established in November 1990, with the Deputy Secretary of Defense approval of the Defense Management Report Decision (DMRD) 941, which directed the development, implementation, and management of a standard DoD EDI system. As part of the move to a "paperless" environment, DMRD 941 identified 16 forms and documents as "key EDI candidates," initiating their replacement with their electronic equivalents.

Defense transportation was one of the four functional areas identified by DMRD 941 as having the potential for significant savings and efficiency improvements resulting from the application of EDI technology. Through the electronic

exchange of information among its trading partners,¹⁹ DoD hopes to achieve increased economies and efficiencies in defense transportation operations. DoD's implementation of EDI in defense transportation involves a systems approach, integrating several functional area application processes and the individual transaction sets used to facilitate the electronic exchange of information. The comprehensive nature of DoD's approach to the implementation of EDI in defense transportation is summarized in two predominant operating concepts: 1) Defense Transportation EDI Operating Concept—Freight and 2) Defense Transportation EDI Operating Concept—Personal Property.

Reflecting the long-term commitment to EDI, DoD efforts are continually expanding the bounds of EDI implementation. Four of the principal future enhancements for defense transportation include: 1) Defense Transportation Payment System, 2) Electronic Funds Transfer, 3) Transaction Set 820, Payment Order/Remittance Advice, and 4) Electronic Submission of Guaranteed Traffic Tenders.

In addition to the specific EDI projects which are an integral part of the overall defense transportation EDI operating concept (e.g., CFM, TOPS, and WHIST), there are

¹⁹ The Department of Defense's trading partners for the electronic exchange of information pertaining to defense transportation operations include: DoD shipping activities, the Military Traffic Management Command (MTMC), the Defense Finance and Accounting Service, Indianapolis Center (DFAS-IN), the General Services Administration (GSA), and commercial carriers.

numerous other initiatives underway. These efforts include projects designed to interface with the freight and personal property EDI operating concepts as well as those which are more service specific in nature.

B. CONCLUSIONS

The Department of Defense is no longer concerned with the question of "Should we adopt EDI technology?" The commitment to EDI exists and the focus now is on "How best do we implement this technology to maximize the return on investment?"

Although the goal of achieving a "paperless" environment may suggest that the primary benefit of EDI implementation is strictly that of paperwork reduction/elimination, this is not the case. As DoD continues in its EDI implementation efforts, it is becoming more evident that the actual benefits of EDI extend beyond the simple reduction/elimination of paper. While the actual realized benefits of EDI implementation will be situationally dependent, the use of electronic (vice paper-based) systems is consistently resulting in more efficient and effective ways to conduct business transactions. DoD business relationships utilizing EDI for conducting transactions among trading partners result in operating improvements and benefits including:

- Reduced paper handling and storage costs. EDI eliminates, or reduces, the volume of paperwork required to conduct many standard business transactions. With this paperwork

reduction comes a corresponding reduction in the costs associated with the personnel and equipment required to manually process and subsequently store paper-based transactions.

- **Increased Accuracy.** Most traditional, paper-based information processing methods are characterized by a data entry/re-entry cycle in which the same data is entered and re-entered numerous times. EDI eliminates this re-entering of data by exchanging data directly between computer systems. This direct exchange of data reduces the possibility of data errors which can result from repeated "handling" and human intervention.
- **Timeliness of Data.** With non-EDI information processing systems, the process of exchanging data is often slow, resulting from a reliance on mail, courier service, facsimile machines, or even telephone. EDI dramatically decreases the time spent exchanging data between users by the virtually instantaneous, computer-to-computer, transmission of information electronically.

The implementation of electronic data interchange represents a significant change in the traditional way the Department of Defense conducts business. Although the results of this research do reflect the significant potential benefits of DoD EDI implementation efforts, it has also identified areas of potential resistance to the change. Barriers to the efficient implementation of EDI must be resolved before DoD can realize the full benefits of conducting business electronically. These barriers include:

- Lack of knowledge and/or understanding of the capabilities and limitations of EDI.
- Decentralization among individual services which has resulted in duplication of effort and the corresponding expenditure of additional scarce resources.
- Potential problems associated with cost-benefit analysis and resourcing decisions due to difficulties in

identifying and quantifying actual cost related savings resulting from EDI implementation.

- Ensuring coordination among trading partners concerning the standardization of data mapping and implementation conventions. These activities are key to unlocking EDI's potential for improving the effectiveness of electronic interorganizational communication. Without these, EDI is nothing more than a communications method which may or may not result in the efficient exchange of information among trading partners.

The implementation of electronic data interchange involves much more than simply automating standard business documents and existing business processes. To realize the full potential of EDI, organizations must review the way they currently conduct business. Those involved with EDI need to realize that electronic data interchange is a technology, a "way of doing things," and not a specific or individual system. As such, it has the potential for application to many different processes currently in use.

The proper implementation of EDI can be a catalyst, streamlining inefficient, redundant, and outdated business practices, resulting in the ability to conduct business faster, more accurately, and at a lower cost than the traditional manual paper-based information processing systems.

C. RESEARCH QUESTIONS

The primary objective of this research was to examine the following question:

What actions have been taken to implement Electronic Data Interchange with Department of Defense transportation operations?

To answer this basic research question, the following subsidiary questions were addressed:

● **What are the essential elements of EDI?**

The essential elements of EDI consist of: EDI standards, EDI software, the EDI platform (i.e., hardware configuration), and the communications linkages. Chapter III (EDI standards) and Chapter IV (EDI software, hardware, and communications) go into specific detail concerning the integration of these resources and the subsequent EDI communications capability.

● **What has been the Department of Defense's approach to the implementation of EDI technology?**

The Department of Defense is committed to the implementation of electronic data interchange and has embraced EDI as the predominant means for achieving Electronic Commerce. DoD's approach to EDI includes implementation with four functional areas: 1) Procurement and Contract Administration, 2) Transportation, 3) Supply and Maintenance, and 4) Fuels. As discussed in Chapter V, this commitment is officially endorsed by such policy initiatives as the Deputy Secretary of Defense's memorandum of May 1988 and the Defense Management Report Decision 941.

● **What benefits may be realized from DoD's EDI implementation with defense transportation operations?**

As with most EDI implementations, the benefits which DoD receives from utilizing EDI in defense transportation

operations consist primarily of reductions in paper handling and storage costs as well as increases in the accuracy and timeliness of data. Chapters II and V address benefits related to the application of EDI technology to information handling processes. Chapter II presents a generalized discussion focusing on benefits typically experienced with EDI use, while Chapter V specifically addresses the direct and indirect benefits (cost savings) which DoD expects as a result of their EDI implementation efforts.

- **What are the specific areas in which EDI has been applied to DoD transportation?**

Chapter VI covers this area in great detail. Primarily, in defense transportation, EDI has been implemented in the areas of shipment information (i.e., GBL) and vendor payment related areas (e.g., tenders and invoices).

- **What are the proposed defense transportation EDI application areas?**

This is discussed in Chapter VI, Future/Proposed Enhancements, and includes 1) Defense Transportation Payment System, 2) electronic funds transfer, 3) Transaction set 820, Payment Order/Remittance Advice, and 4) electronic submission of guaranteed traffic tenders.

- **What, if any, barriers exist to the optimal implementation of EDI?**

As discussed in Chapter VI, the barriers to the efficient implementation of EDI include 1) lack of knowledge and/or

understanding, 2) decentralization of effort, 3) cost-benefit analysis and resourcing, and 4) standardization.

APPENDIX A

LIST OF ACRONYMS

AMC	=	Air Mobility Command
ANSI	=	American National Standards Institute
ASC X12	=	Accredited Standards Committee X12
ASD (P&L)	=	Assistant Secretary of Defense (Production and Logistics)
CFM	=	CONUS Freight Management
CFR	=	Code of Federal Regulations
CMOS	=	Cargo Movement Operations System
CONUS	=	Continental United States
CRAF	=	Civil Reserve Air Fleet
CSL	=	Computer Systems Laboratory
DDN	=	Defense Data Network
DEALS	=	Do-It-Yourself Electronic Data Interchange Automated Loading System
DES	=	Data Encryption Standard
DFAS-IN	=	Defense Finance and Accounting Service - Indianapolis Center
DISA	=	Data Interchange Standards Association, Inc.
DITY	=	Do-It-Yourself
DLA	=	Defense Logistics Agency
DMRD	=	Defense Management Report Decision
DoD	=	Department of Defense

DTRS = Defense Transportation Payment System
 DTTS = Defense Transportation Tracking System
 EA = Executive Agent
 EC = Electronic Commerce
 EDI = Electronic Data Interchange
 EDIFACT = United Nations/EDI for Administration,
 Commerce, and Transport
 EFT = Electronic Funds Transfer
 FIPS = Federal Information Processing Standard
 GBL = Government Bill of Lading
 GSA = General Services Administration
 GTN = Global Transportation Network
 HEAT = Household Goods Electronic Data Interchange
 Automated Transactions
 IBS = Integrated Booking System
 ITV = In-Transit Visibility
 JCS = Joint Chiefs of Staff
 LMI = Logistics Management Institute
 MAC = Message Authentication Code
 MSC = Military Sealift Command
 MTMC = Military Traffic Management Command
 MTMC-CF = Deputy Chief of Staff for Information
 Management - CONUS Freight
 MTMC-IN = MTMC Inland Traffic Directorate
 MTPP = MTMC Personal Property Directorate
 NAVMTO = Navy Material Transportation Office

NFAF = Naval Fleet Auxiliary Force
 NLN = NAVSUP Logistics Network
 PPSO = Personal Property Shipping Office
 PRB = Procedures Review Board
 RRF = Ready Reserve Force
 TCC = Transportation Component Command
 TDCC = Transportation Data Coordinating Committee
 TMS = Transportation Management System
 TOPS = Transportation Operational Personal Property
 Standard System
 TPA = Trading Partner Agreement
 TVCB = Transportation Voucher Certification Branch
 UCS = Uniform Communication Standard
 USTRANSCOM = United States Transportation Command
 VAN = Value Added Network
 WHIST = Worldwide Household Goods Information System
 for Transportation
 WINS = Warehouse Information Network
 WPS = Worldwide Port System

APPENDIX B

DMRD 941 DOCUMENTS BY OPPORTUNITY AREA

PROCUREMENT/CONTRACT ADMINISTRATION

DD Form 250 - *Material Inspection and Receiving Report.*

The DD Form 250 is a multiple purpose document. It is primarily used for inspection, acceptance, and receiving of materials from a contractor, but is also used as an invoice if a contractor chooses. It has a standard distribution: to the consignee, the contract administration office, the purchasing office, and the payment office. ANSI transaction sets 810, 856, 861, and 863 could be substituted for the DD Form 250.

SF 1443 - *Contractor's Request for Progress Payments.* The

General Services Administration Standard Form (SF) 1443 is used by contractors to request progress payments from DoD. Progress payments are usually made on a regular and continual basis. The request for payment and the actual payment process itself could be accomplished by electronic funds transfer (EFT). ANSI transaction sets 810 and 820 are ideal for this application.

SF 30 - *Amendment of Solicitation/Contract Modification.*

The SF 30 is used to modify contracts, orders, or

solicitations. Contractors receive the form and use it to adjust their internal proposal preparation and contract/order management systems. EDI transmission of this document will permit better visibility over contract details and improve the ability to track contract line items, unit prices, delivery schedules, engineering changes, and amended shipping instructions. ANSI transaction sets 850 and 860 may apply to portions of the SF 30.

SF 18 - Request for Quotations. Although the SF 18 is principally a paper document, DoD executes as much as 50 percent of its requests for quotations by telephone. The SF 18 is used by prospective DoD suppliers, who complete the unit price and certification sections and then return the form to DoD. ANSI transaction sets 840 and 843 are designed for requesting and sending quotations electronically.

SF 129 - Solicitation Mailing List Application. The SF 129 allows prospective vendors to enroll in the buying agency's automated bidders' mailing list system. It is completed by the vendor and mailed to the buying office where it is reviewed and entered into an automated mailing list. The SF 129 is an excellent candidate for EDI, in

part because the Office of Federal Procurement Policy wants to develop a national bidders list.

DD Form 1155 - Order for Supplies and Services. Functioning as either a purchase order for small purchases (less than \$25,000) or delivery orders for indefinite delivery contracts, DD Form 1155 is one of the most pervasive forms in DoD. The ANSI transaction set 850 is well suited for transmitting DD Form 1155 information.

TRANSPORTATION

SF 1103 - Freight GBL; CBL; SF 1113 - Public Voucher. These documents are used by DoD to procure freight transportation and related services from commercial carriers. The SF 1103 (freight Government bill of lading), used to procure non-local service, is a seven-part document distributed to the carrier, shipper, consignee, Military Traffic Management Command (MTMC), and finance center. The CBL (commercial bill of lading) is used to procure local small package services. Carriers submit the SF 1113 to the finance center as an invoice. The ANSI transaction sets 820 and 858 could accommodate these documents.

SF 1203 - Personal Property GBL; 619/619-1 - Statement of Accessorial Services Performed; and SF 1113 - Public Voucher. These documents are used by DoD to procure personal property transportation and related services from commercial carriers. The SF 1203 is a seven-part document distributed to the carrier, shipping office, receiving office, MTMC, and finance center. The 619 and 619-1, which are used to confirm the performance of additional personal property services, must be submitted along with the SF 1113 for payment to the finance center. The ANSI transaction sets 820 and 858 are suitable for these documents.

SF 1169 - Government Travel Request; SF 1113 - Public Voucher. These documents are used by DoD to procure travel services. The SF 1169 is distributed to the finance center by the passenger carrier along with an SF 1113 for payment. The ANSI transaction sets 820 and 858 could be applied to these documents.

Voucher Stub and Check. These documents are used to pay carriers for transportation-related services. The check is produced by the finance center, combined with the stub from the public voucher (SF 1113), and then mailed to the carrier. The voucher stub serves as the carrier's

remittance advice. The ANSI transaction set 820 is suitable for these documents.

MT 364R - Standard Tender. The tender specifies the freight rates under which carriers propose to move DoD cargo. It provides information for transportation pricing, carrier selection, auditing, and payment. Carriers must submit nine copies to MTMC for processing. MTMC distributes copies of the tender to its Eastern and Western Area Commands, the General Services Administration, Navy Material Transportation Office, and to the carrier. The ANSI transaction set 602 has been created to replace this document.

SUPPLY/MAINTENANCE

SF 364 - Report of Discrepancy (Supply). The SF 364, administered by the Defense Logistics Standard Systems Division, reports shipment conditions such as incorrect quantity, improper labelling, or poor conditions. It is sent to the DoD item manager or an item manager from an affiliated civil agency, such as the General Services Administration.

SAV 926 - Monthly Report, Receipt of Repairables. The SAV (Standard Aviation Systems Command) 926, an Army document, is generated monthly by commercial maintenance activities

to notify inventory control points of the quantity and status of unserviceable assets sent to them for repair. The other Military Services use forms comparable to the SAV 926.

SF 368 - Product Quality Deficiency Report. The SF 368 is administered by the Defense Logistics Agency and reports material defects stemming from the original manufacturer. The SF 368 may require product analysis or testing by laboratories and contact with the vendor. Like the SF 364, it is sent to the DoD item manager or an item manager from an affiliated civil agency.

SF 361 - Transportation Discrepancy Report. The SF 361, administered by MTMC, is used to report conditions such as damage to the material while in transit or delivery to the wrong recipient. It is generally sent to the appropriate MTMC area command, and to the ultimate consignee if it is issued by an intermediate receiver. A copy is also sent to the commercial carrier if one is involved.

FUELS

DD Form 1898 - Aviation Fuels Sales Slip. The DD Form 1898, an aviation fuel sales slip or "delivery ticket," is used to document that the aviation fuel invoiced for payment on an into-plane invoice was actually delivered to

a Government activity. DD Form 1898 into-plane receipts are signed by the pilot, who retains a copy. The fuel company sends another copy of the delivery ticket with its into-plane invoice to the Defense Fuels Supply Center for payment. If the hardcopy DD Form 1898 has valid nameplate information and is signed by a Government representative, then the Defense Fuels Supply Center certifies the invoice for payment. ANSI transactions sets 810 and 856 can be used to replace the DD Form 1898 and commercial invoice.

LIST OF REFERENCES

1. Quinn, F. J., "Why you Should Know About EDI," Traffic Management, Vol. 30, No.7, p. 45, July 1991.
2. Emmelhainz, M. A., EDI: A Total Management Guide, 2d ed., Van Nostrand Reinhold, 1993.
3. Monczka, R. M. and Carter, J. R., Electronic Data Interchange: Managing Implementation in a Purchasing Environment, Graduate School of Business Administration, Michigan State University, 1987.
4. X12/DISA Information Manual 1993, Data Interchange Standards Association, Inc., January 26, 1993.
5. Hamilton, W. P. III and Henderson, M. M., Forging a Partnership Through EDI, Logistics Management Institute, Report DL203LN3, July 1992.
6. An Introduction to Electronic Data Interchange, Data Interchange Standards Association, Inc., January 1, 1993.
7. Hardcastle, T. P., EDI Planning and Implementation Guide, Logistics Management Institute, Report DL203RD1, August 1992.
8. Title 41 of the Code of Federal Regulations, Part 101-41, 1 July 1992.
9. Hinge, K. C., Electronic Data Interchange, From Understanding to Implementation, AMA Membership Publications Division, 1988.
10. Telephone conversation between Charley Hamlin, Roadway Express, Inc., and the author, 21 January 1994.
11. Defense Traffic Management Regulation, AR 55-355, NAVSUPINST 4600.70, AFR 75-2, MCO P4600.14B, DLAR 4500.3, 31 July 1986.
12. DoD Electronic Data Interchange (EDI) Convention: ASC X12 Transaction Set 858 Freight Government Bill of Lading Shipment Information (Version 003010), Defense Logistics Agency, Report PL205LN1, February 1993.

13. Hardcastle, T. P. and Heard, T. W., A Business Case for Electronic Commerce, Logistics Management Institute, Report DL001-06R1, September 1990.
14. Deputy Secretary of Defense, Defense Management Report Decision, No. 941, Subject: Implementation of Electronic Data Interchange in DoD, 12 NOV 1990.
15. Deputy Secretary of Defense memorandum to Secretaries of the Military Departments and Directors of the Defense Agencies, Subject: Electronic Data Interchange of Business-Related Transactions, 24 MAY 1988.
16. Deputy Under Secretary of Defense (Acquisition Reform), DoD Electronic Commerce (EC)/Electronic Data Interchange (EDI) in Contracting Report, Vol. 2, U.S. Government Printing Office, 20 December 1993.
17. National Defense University, Armed Forces Staff College, The Joint Staff Officer's Guide 1993, p. I-8, U.S. Government Printing Office, 1993.
18. "U.S. Transportation Command," Defense Transportation Journal: 1993 Almanac, Vol. 49, No. 1, February 1993.
19. "Air Mobility Command," Defense Transportation Journal: 1993 Almanac, Vol. 49, No. 1, February 1993.
20. "Military Traffic Management Command," Defense Transportation Journal: 1991 Almanac, Vol. 47, No. 1, February 1991.
21. "Military Sealift Command," Defense Transportation Journal: 1993 Almanac, Vol. 49, No. 1, February 1993.
22. Bridges, W. M. and Yea, T., Doing Business with DoD Using Electronic Data Interchange: An Information Package for Freight Carriers, Logistics Management Institute, Report DF101LN9 (revised), September 1993.
23. Bridges, W. M., Frohman, H. L., Ledder W. R., and Yea, T., EDI Trading Partner Agreement for Defense Transportation: Freight, Logistics Management Institute, Report PL205LN4, March 1993.
24. Ledder, W. R., Status Report on the Implementation of Electronic Data Interchange in Defense Transportation, Logistics Management Institute, Report PL005LN1, April 1992.

25. Heard, T. W. and Creedon, M. A., How to Submit EDI Tenders to the DoD for Transportation of Freight in the Continental United States, Logistics Management Institute, Report MT^o01TR2, July 1991.
26. Telephone conversation between Mr. Tom Hicks, MTIM-CF, Military Traffic Management Command and the author, 8 February 1994.
27. Alderson, J., "Electronic Data Interchange: Military Implements EDI to Speed and Facilitate Transportation Tenders," Defense Transportation Journal, Vol. 49, No. 2, April 1993
28. Heard, T. W. and Ledder, W. R., Electronic Data Interchange in Defense Transportation, Logistics Management Institute, Report ML538R1, October 1987.
30. Frohman, H. L. and Ledder, W. R., Defense Transportation's EDI Program: A Security Risk Assessment, Logistics Management Institute, Report PL205LN5, May 1993.
31. Telephone conversation between Mr. Dave Yamerick, General Services Administration and the author, 27 October 1993
32. Beyer, A. H. and Bridges, W. M., Doing Business with DoD Using Electronic Data Interchange: An Information Package for Personal Property Carriers, Logistics Management Institute, Report MT001LN3, August 1992.
33. Heard, T. W. and Bridges, W. M., An Electronic Future for Defense Transportation Management, Logistics Management Institute, Report AL711R1, January 1988.
34. Doton, L. C., "CONUS Freight Management System," Translog, Vol. 7, No. 3, Third Quarter 1993.
35. Beezley, T. C. III, "Transportation Operational Personal Property Standard System," Translog, Vol. 7, No. 3, Third Quarter 1993.
36. Bridges, W. M. and Frohman, H. L., An Electronic Data Interchange Prototype for Exchanging Personal Property Shipment Information, Logistics Management Institute, Report MT001R1, March 1992.
37. Telephone conversation between Mr. Steve Jebo, Military Traffic Management Command and the author, 15 February 1994

38. Bridges, W. M. and Yee, T., Promoting Freight Carrier EDI Participation with the Defense Finance and Accounting Service - Indianapolis Center, Logistics Management Institute, Report DF101RD1, July 1993.
39. Defense Finance and Accounting Service, Defense Transportation Payment System (DTRS), In-Process Review briefing, 30 April 1993.
40. Telephone conversation between Mr. Dennis Rickey, Transportation Operations Directorate, Systems Management Office (DFAS-IN-TA), Defense Finance and Accounting Service-Indianapolis Center and the author, 7 February 1994.
41. Bridges, W. M. and Kaplan, B. J., Implementation of Electronic Funds Transfer for Transportation Vendor Payment: A Program for the Defense Finance and Accounting Service Indianapolis Center, Logistics Management Institute, Report PL005R2, February 1992.
42. Creedon, M. A., An Electronic Commerce Strategy for MTMC's Guaranteed Traffic Program, Logistics Management Institute, Report MT901R1, October 1992.
43. Lt. Col. Wasem, V., Headquarters United States Air Force, Directorate of Transportation, Cargo Movement Operations System (CMOS): Information Fact Sheet, Pentagon, Washington D.C., January 1994.
44. LTC Clifford, S. M., United States Army, Office of the Director of Information Systems for Command, Control, Communications, and Computers, Request for FY94 and FY95 Electronic Data Interchange (EDI) Funding Requirements and Information for the EDI Projects Data Base, Pentagon, Washington D.C., January 1994.
45. Kaskoff, H. A., "Worldwide Port System," Translog, Vol. 7, No. 3, Third Quarter 1993.
46. Hicks, T., Office of the Deputy Chief of Staff for Information Management, HQ, MTMC, MTIM-CF, February 1994.
47. United States Marine Corps, Marine Corps Strategic Plan for Electronic Data Interchange, Headquarters Marine Corps Installation and Logistics Department, August 1992.
48. Naval Transportation Office Automation, "Transportation Management System," Navy Transportation Workshop, Norfolk, VA, 14-16 September, 1993

49. Naval Supply Systems Command, Strategic Plan for Electronic Data Interchange, Naval Supply Systems Command, Washington, DC, January 1993.
50. Hammer, M., "Reengineering Work: Don't Automate, Obliterate," Harvard Business Review; Vol. 68, No. 4, pp. 104-112, July-August 1990

BIBLIOGRAPHY

- Bae, H. D., Internal Control in an EDI Environment, Master's Thesis, Naval Postgraduate School, Monterey, California, December 1991.
- Barrett, C., "Making Haste Slowly With EDI," Traffic World, Vol. 232, No. 7, November 16, 1992.
- Baum, M., "Legal Issues in Implementing EDI: Issues Related to Legal Documents," in Meeting the Challenge of EDI: A Perspective on the Broader Issues Facing Carriers, Shippers, and Suppliers: Proceedings of the Symposium in Boston, Massachusetts, June 22-23, 1989, by the Transportation Research Forum, 1989, p.58.
- Chung, J. D., Electronic Data Interchange, Master's Thesis, Naval Postgraduate School, Monterey, California, March 1991.
- Coyle, J. J., Bardi, E. J., and Cavinato, J. L., Transportation, 3rd ed., West Publishing Company, 1990.
- "Defense Department Index", Defense Transportation Journal (1993 Almanac), Vol. 49, No. 1, February 1993.
- Featherstone, H., and McEwen, M., Strategic Plan for Electronic Data Interchange, Logistics Management Institute, Report NA103, November 1991.
- Fisher, S., "Moving Data Using EDI," Byte, Vol. 16, No. 4, April 1991.
- Frohman, H. L., A Guide to EDI Translation Software, Logistics Management Institute, Report PL205RD1, 1992 Edition.
- Frohman, H. L., Kaplan, B. J., and Ledder, W. R., EDI Telecommunications Strategy for Defense Transportation, Logistics Management Institute, Report PL005TR1, April 1990.
- Frohman, H. L., and Ledder, W. R., EDI Training Strategy and Requirements for Defense Transportation, Logistics Management Institute, Report PL005LN3, April 1993.

- Gupta, Y. P., and Neel, G. A., "The Origin of EDI and Changes Associated With Its Implementation," Industrial Engineering, Vol. 24, No. 8, August 1992.
- Hardcastle, T. P., A Standard EDI System for the Department of Defense, Logistics Management Institute, Report DL001-03, January 1992.
- Henderson, M. M., Evaluation of Existing EDI Implementation Guidelines, Logistics Management Institute, Report PL911TR1, March 1990.
- Henderson, M. M., and Lewis, A., DoD Implementation Guidelines for Electronic Data Interchange (EDI): Volume I, Logistics Management Institute, Report DL001-01R1, December 1991.
- Henderson, M. M., and Lewis, A., DoD Implementation Guidelines for Electronic Data Interchange (EDI): Volume II, Logistics Management Institute, Report DL001-01R1, December 1991.
- Ledder, W. R., and Snyder, T. W., Test Plan for the Electronic Exchange of Shipping Information with the Defense Transportation Tracking System, Logistics Management Institute, Report PL005LN2, June 1992.
- MTMC, "EDI in Defense Transportation," briefing to EDI Executive Committee, April 1993.
- Muller, G., Intermodal Freight Transportation, 2d, Eno Foundation for Transportation, Inc., 1989.
- Ott, J. J., Featherstone, H. L., and James, W. T. III, Opportunities to Implement Electronic Data Interchange at the Navy Material Transportation Office, Logistics Management Institute, Report NA204LN1, July 1993.
- Payne, J. E., and Anderson, R. H., A Change of Course: The Importance to DoD of International Standards for Electronic Commerce, RAND, Report R-4088-P&L, 1991.
- Payne, J. E., and Anderson, R. H., Electronic Data Interchange (EDI): Using Electronic Commerce to Enhance Defense Logistics, RAND, Report R-4030-P&L, 1991.
- Ullrich, T. S., Application of Electronic Data Interchange (EDI) to Marine Corps Procurement, Master's Thesis, Naval Postgraduate School, Monterey, California, June 1991.

INITIAL DISTRIBUTION LIST

	No. Copies
1. Defense Technical Information Center Cameron Station Alexandria VA 22304-6145	2
2. Library, Code 052 Naval Postgraduate School Monterey CA 93943-5002	2
3. Director Defense Logistics Studies Information Exchange US Army Logistics Management College ATTN: ATSZ-DL Fort Lee, VA 23801-6043	1
4. Professor Dan C. Boger (Code SM/Bo) Naval Postgraduate School Monterey, CA 93943-5000	1
5. Professor David G. Brown (Code SM/Bz) Naval Postgraduate School Monterey, CA 93943-5000	1
6. Department of the Navy Naval Supply Systems Command ATTN: CAPT T. A. Rorex (SUP 44) 1931 Jefferson Davis Highway Arlington, VA 22241-5360	1
7. Department of the Army Headquarters MTMC ATTN: MTIM-I (Ursula Loy) 5611 Columbia Pike Falls Church, VA 22041-5050	1
8. HQDA, DISC4 SAIS-IDP (Attn: LTC Clifford) 107 Army Pentagon Washington, DC 20310-0107	1
9. HQ USAF/LGTX Room 4B322 ATTN: Lt. Col. Wasem 1030 Air Force Pentagon Washington, DC 20330-5130	1

10. Commandant of the Marine Corps 1
LFT HQ USMC
LFT-1 ATTN: W. Fitzhugh
2 Navy Annex
Washington, DC 20380-1775
11. Logistics Management Institute 1
ATTN: Harold Frohman
6400 Goldsboro Road
Bethesda, MD 20817
12. LT John G. Meier III 2
235 Copper St.
Ishpeming, MI 49849