

Historic, archived document

Do not assume content reflects current scientific knowledge, policies, or practices.

FARM HOME CONVENIENCES

MADGE J. REESE

Assistant in Home Demonstration Work
Office of Extension Work, South



FARMERS' BULLETIN 927

UNITED STATES DEPARTMENT OF AGRICULTURE

Contribution from the States Relations Service
A. C. TRUE, Director

Has been rev.
--see rev.ed.
binders at
end of file.

Washington, D. C.

March, 1918

Show this bulletin to a neighbor. Additional copies may be obtained free from the
Division of Publications, United States Department of Agriculture

“WHATEVER LESSENS WOMAN’S WORK BENE-
FITS THE RACE.”

CONSERVATION of time and energy is obviously one of the problems of the housekeeper. Time and strength may be saved in two ways, first by taking thought as to the way one uses strength, and second by making use of labor-saving equipment. This may easily make the difference between a tired, overworked housekeeper and one who has some time and energy left for reading and recreation after the day’s work is done.

Home conveniences have already been installed in several thousand country homes under the direction of State and county home demonstration agents. This phase of demonstration work has not only effected a real saving in the work of the home, but it is helping the farm woman to get a greater amount of happiness out of her daily tasks.

The household conveniences described in this bulletin have been selected because they may be made at a moderate cost by anybody who has a few simple tools and the ability to use them. Their use also yields a large return in comfort, economy, and sanitation.

Valuable suggestions have been secured from State publications and from the experiences of State and county home demonstration agents.

FARM HOME CONVENIENCES.

CONTENTS.

	Page.		Page.
The kitchen cabinet.....	3	The cold box.....	18
The fireless cooker.....	5	Equipment for home butter making.....	18
Sponge box or bread raiser.....	7	Cheese-making equipment.....	21
Dish drainer.....	9	The shower bath.....	21
Heights of working surfaces.....	10	Well protection and waterworks.....	23
Serving tray.....	10	Fly trap.....	29
Folding ironing board.....	13	Window screen.....	30
Rack for portable ironing board.....	13	Cookstove drier or evaporator.....	30
The iceless refrigerator.....	14	The cleaning closet.....	31

THE KITCHEN CABINET.

A CARPENTER WITHOUT HIS BENCH loses much time in getting the right tools and in putting them away. A chemist can not do systematic laboratory work without a well-arranged desk. A kitchen cabinet is just as important to the housekeeper as the bench to the workman or the laboratory desk to the chemist. With it the housekeeper can sit down comfortably with her whole kitchen workshop within easy reach. It saves walking to and fro to gather up this thing and that, to prepare the food. Every kitchen should have a stool of the right height to enable the worker to sit at her work at the cabinet. The homemade cabinet shown in the illustration (fig. 1) is sanitary, convenient, and attractive. It is especially convenient and compact for kitchens in which space is limited.

A homemade cabinet can be built with moderate expense if outside labor need not be employed. If both lumber and labor must be purchased, the cost will equal that of a ready-made cabinet. The cabinet must be made of good wood, well seasoned. That is the most important consideration. Poorly seasoned wood warps and swells and is a constant annoyance in opening and closing doors and drawers.

The cabinet shown in the illustration is 6 feet 3 inches high to the top of the closet, 31 inches high to the top of the table. It is 21 inches deep and 48 inches wide. The part of the cabinet below the table contains the flour bin, large drawer, rack, and dough or pastry board. The bin is fastened to the frame with loose-pin hinges. By removing the pins the entire bin can be removed, cleaned, and replaced. The bin can be lined with tin to make it moisture, insect,

and mouse proof. The dough board should be made of a wood that is tasteless and odorless and should be fitted well in the opening just below the table. A batten is tongued and grooved on each side of the board to prevent it from warping. The roomy drawer can be used for small utensils. The open space below the drawer can be occupied by the kitchen stool or the homemade fireless cooker when they are not in use.

Pie pans, lids, and covers have a most convenient place in the rack below the drawer. A drop table 21 inches wide and 19 inches long increases the table surface. This table is supported by inexpensive folding brackets.

The upper part of the cabinet consists of a closed compartment, three drawers, three open shelves, knife rack, and row of screw hooks for hanging utensils. The closed compartment is for package goods and large utensils. The drawers are for kitchen linen and other things needed in daily use. The lower shelf is 5 inches in depth, while the upper shelves are $7\frac{1}{2}$ inches. On these shelves are kept coffee, tea, sugar, and spice jars. Three inches below the lower shelf there is a strip $1\frac{1}{2}$ inches wide which holds the screw hooks. The knife rack is made by sawing slashes 1 inch deep in a piece of material 2 inches wide.

The cabinet is finished with two coats of white paint and one coat of white enamel. It can be easily kept clean and sanitary. Metal or wooden handles may be used.

THE FIRELESS COOKER.

Fireless cookers are now being made and used in hundreds of country homes. What is more pleasing to the farm woman than to put her dinner in the fireless cooker before she drives to town to market her products, and upon returning find it is ready for serving?

The fireless cooker offers several advantages. The first is economy of time, as the housekeeper may leave the food cooking without worrying about the results while she is engaged in other household duties or visiting her friends.

Some foods are improved by long cooking at relatively low temperature. The texture and flavor of tougher cuts of meat, old, tough fowl, and ham are improved by slow cooking. Cereals, dried legumes, and dried fruits are more palatable and wholesome when cooked for a long time. Soups and stews are delicious when cooked in the cooker. Baking, however, can not be done very conveniently and satisfactorily in the ordinary homemade fireless cooker.

In some sections of the country economy of fuel must be an important consideration. The food for the cooker may be started on the wood or coal range when the morning meal is being prepared. In warm weather the use of a fireless cooker and a kerosene stove means not only economy of fuel, but also comfort.

The food to be cooked is first heated to boiling point on the stove in the cooking vessel and then this vessel, covered with a tight lid, is quickly placed in the cooker, where the cooking continues. The cooker is so constructed that the heat does not escape. For long cooking it is necessary to place in the cooker under the cooking vessel a hot radiator. A soapstone is the best radiator and can be purchased at most hardware stores for 50 cents. A stove lid, a brick or disk made of concrete, heated and placed in the cooker, may serve as the radiator.



FIG. 1.—Kitchen cabinet.

DIRECTIONS FOR MAKING FIRELESS COOKER.

A tightly built box, an old trunk, a galvanized-iron ash can, a candy bucket, a tin lard can, a lard tub, and a butter firkin are among the containers that have been used successfully in the construction of fireless cookers. (Figs. 2 and 3).

The inside container or nest which holds the vessel of hot food may be a bucket of agate, galvanized iron, or tin. This nest must be deep enough to hold the radiator and the vessel of food but not large enough to leave much space, as the air space will cool the food. The inside container must have a tight-fitting cover, and straight sides are desirable.

The packing or insulation must be some material which is a poor conductor of heat. The following materials may be used and they should be dry: Lint cotton, cotton-seed hulls, wool, shredded newspaper, Spanish moss, ground cork, hay, straw, and excelsior.

Sheet asbestos $\frac{1}{8}$ inch thick and heavy cardboard have proved to be the best lining for the outer container and the wrapping for the nest. Heavy wrapping paper or several sheets of newspaper may be used for lining the outer container, but the nest should be wrapped with asbestos or heavy cardboard to prevent the hot stone scorching or burning the packing.

1. It is well to have the outside container large enough to permit 4 inches of packing below and around the sides of the nest. If a



FIG. 2.—Materials assembled for making a fireless cooker.



FIG. 3.—The completed fireless cooker.

cooker is being made with two nests, 6 inches of packing should be allowed between the nests. Pack into the bottom of the lined outer container 4 inches of the packing. Place the nest or inside container wrapped with asbestos or heavy cardboard and hold steady while the packing is put around tightly and firmly until it reaches the top of the nest.

2. Make a collar, as shown in illustration, of cardboard, sheet asbestos, or wood to cover the exposed surface of the insulating material. This collar should fit tightly.

3. Make a cushion which when filled with the packing will be at least 4 inches thick and will fill completely the space between the top of the nest and the lid of the outside container. It should fit against the top tightly enough to cause pressure when the lid is closed.

4. The outside of the fireless cooker can be made more attractive by staining or painting it. The lid may be held in place by screen-door hooks and eyes. The cooker may be placed on casters so that it can be easily moved.

Selected recipes for preparing food to be cooked in the fireless cooker may be found in Farmers' Bulletin 771, *Homemade Fireless Cookers and Their Use*.

SPONGE BOX OR BREAD RAISER.

In making bread the housekeeper often finds it difficult to hold her sponge or dough at the right temperature so that it will rise in a shorter period of time. She will find a sponge box or bread raiser (fig. 4) a great help in keeping the proper temperature. Such a box can be made from an ordinary dry-goods packing box.

A box 26 by 20 by 20 inches is a convenient size. About 10 inches from the bottom of the box a shelf made of slats or strips of wood

rests on cleats fastened to the sides of the box. A second shelf is placed 4 inches above the lower one. The shelves can be removed when cleaning the box. Below the lower shelf a sheet of galvanized iron slightly wider than the shelf is inserted. It is curved in order to make it slip in and stay in place securely. This prevents scorching of the lower shelf when a lamp is placed below and also helps to distribute the heat more evenly. The door is hinged and fastened with a thumb-latch or hook and staple.

Several small holes are bored in the lower and upper parts of the sides and in the top of the box to promote circulation of air. A cork which has been bored through the center to admit a straight thermometer is inserted in one of the holes in the top of the box. A Fahrenheit chemical thermometer that registers as high as 100° can be used. Such a thermometer may be ordered through a hardware dealer or directly from an instrument dealer.

To avoid all danger of fire, the box should be lined with asbestos or tin when a kerosene lamp is used for heating the box. If an electric light is used, the lining is not necessary. A 16-candlepower light will heat the box nicely. A small and inexpensive night lamp is placed in the bottom of the box and a shallow pan of water is placed on the lower shelf so that the air in the box will be kept moist.

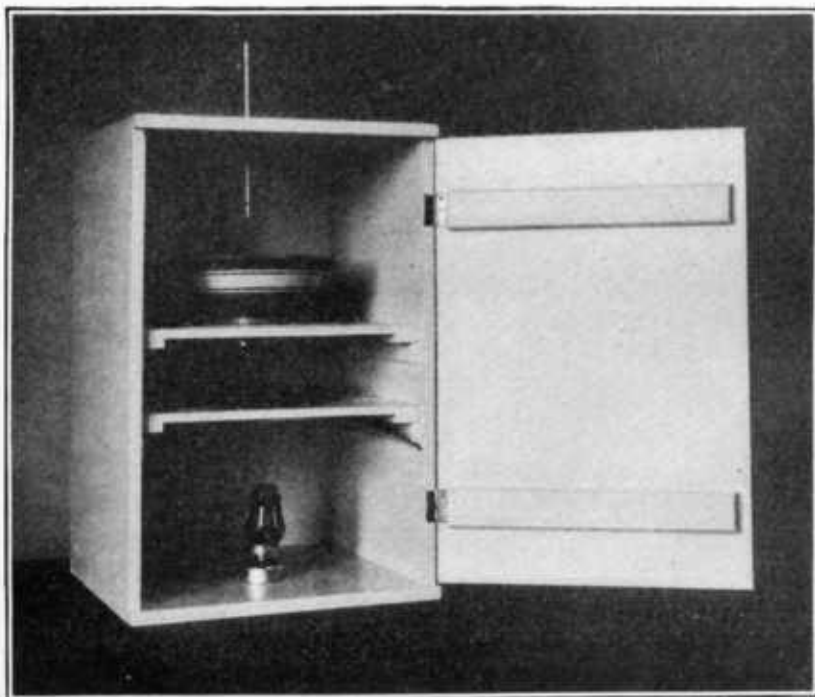

FIG. 4.—Sponge box.

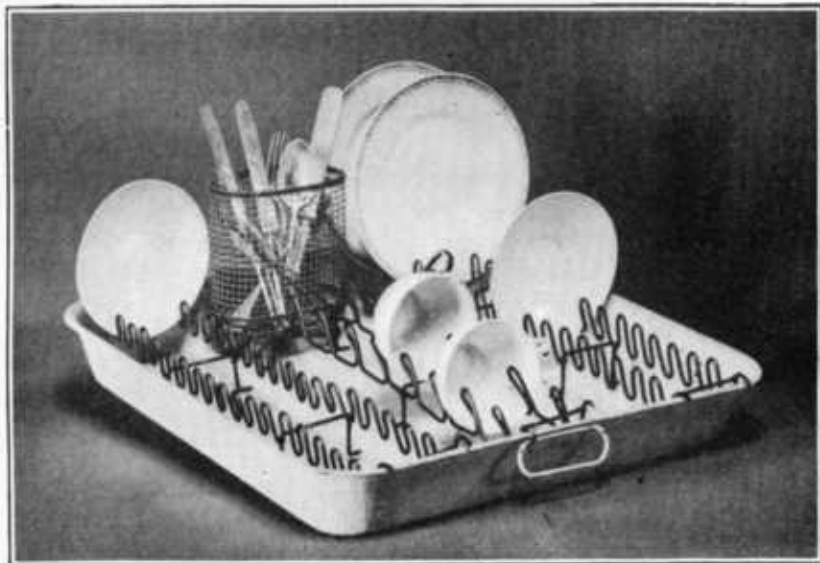

FIG. 5.—Dish drainer.

The bowl of sponge or pans of dough are placed on the upper shelf. The temperature of the box should be kept as near 86° F. as possible (80° to 88° F.) when bread is being made in the quick way. If a sponge is set overnight 65° to 70° F. is the better temperature until the dough is made in the morning, after which the temperature may be increased to 86° F. The temperature in the box may be varied by raising or lowering the flame of the lamp or by using warm or cold water in the shallow pan.

DISH DRAINER.

Perhaps no time spent in housework is more begrudged by the housekeeper than that spent in washing and wiping dishes. A dish drainer not only saves time and labor but it does away with the too often insanitary dish towel.

A most satisfactory dish drainer, as shown in figure 5, can be made by using an ordinary bread or biscuit pan and racks made of soft No. 12 or 14 wire. By using a pair of pliers the wire can be bent into the proper shape for forming the racks. The racks fit into the pan and hold the dishes out of the water. The compartment for silver is made of poultry netting. This compartment could be made of screen wire or a tin can with holes in the bottom might be used.

After the dishes are washed they are stacked in the racks and scalded with hot rinsing water. The pan catches the drip, and the dishes upon standing dry clean and lintless. If the drainer is used on the drain board of a sink a small hole can be made in the pan

and the drip drained immediately into the sink. The wire racks can easily be removed so that the pan can be used for other purposes.

HEIGHTS OF WORKING SURFACES.

Kitchen tables and the bottom of sinks are usually too low for working surfaces when the housekeeper is standing. Low working surfaces are often responsible for tired backs and rounded shoulders because of the undue stooping and the strain on the arms and shoulders. The following figures show the proper level of working surfaces for the height of the housekeeper:

Height of woman.	Proper height of working surface.
	Inches.
4 feet 10 inches.....	27
5 feet.....	28
5 feet 2 inches.....	29
5 feet 4 inches.....	30
5 feet 6 inches.....	31

The kitchen table can be raised to the proper height by the use of blocks of wood. Different types of blocks for raising the height of tables are shown in figure 6.

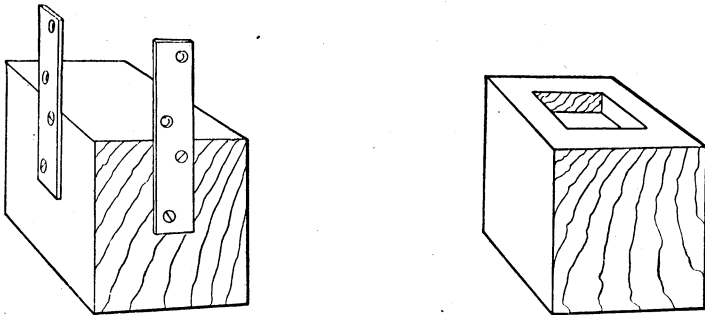

FIG. 6.—Blocks for raising tables.

(a) A block of wood with a socket in which the table leg fits securely.

(b) A block of wood with metal strips and screws or nails for fastening the table legs or the cabinet table.

SERVING TRAY.

The serving tray (fig. 7) is a strength and time saver. The tray saves many trips between the dining room and kitchen, both in serving and in clearing away meals, especially in a large household where many dishes must be handled. The top and shelf spaces are sufficient to remove all dishes to or from the table in one trip. It saves steps in

servicing refreshments at social occasions. It is invaluable to use as a bedside tray in the sick room. The tray when made well is attractive as well as useful and may serve as a reading table or flower stand. (Fig. 8.)

The upper part of the serving tray is box shaped, 16 inches wide and 26 inches long. This is supported by four legs $1\frac{1}{2}$ by $1\frac{1}{2}$ inches, which measure 31 inches from the floor to the top of the tray. The top of the tray or the lid of the china compartment is edged by a



FIG. 7.—Serving tray, opened.

1½-inch molding. The china compartment is 4½ inches deep and is painted white within. On the sides of this compartment are little screw hooks on which cups may be hung. There is space in the compartment for serving dishes for six.

Below this serving compartment is a drawer 2 inches deep, which is divided into two parts. One side is used for linen and one side for silver. The side used for silver is lined with dark-colored felt or outing flannel.

In the space below the drawer a large undershelf is placed. The serving tray is put on noiseless swivel castors, thus allowing the table to turn completely around, which is a great convenience. Instead of castors, small swivel wheels or the small wheels of a baby carriage or toy wagon may be used. A tray made by the dimensions given above is a convenient size and one that will go through doorways without danger of bumping.



FIG. 8.—Serving tray, closed.

FOLDING IRONING BOARD.

The ironing board shown in figure 9 can be fastened up against the wall and is out of the way when not in use. It should be made of well-seasoned 1 or $1\frac{1}{4}$ inch material. A board of convenient size can be made by the following dimensions: 4 feet 8 inches long, 15 inches wide at the attached end, and 8 inches at the free end. About 2 feet from the attached end the board begins to taper gradually. The free end is rounded.

A strip $1\frac{1}{4}$ by 4 by 15 inches is securely fastened by screws to the wall at a convenient height. The height at which the board is placed varies with the height of the user. For a woman of average height it should be 31 or 32 inches. The board is hinged to the wall strip with two No. 3 butt hinges. (Fig. 9.)

The leg or brace, made of material 1 inch thick and 4 inches wide, is fastened with a No. 3 butt hinge to a board strip 1 by 4 by 8 inches. The board strip is screwed to the underside of the board 11 inches from the free end. The length of the brace depends upon the height of the board, and when the board is in position the brace rests against the baseboard of the wall. Skirts may be easily ironed without changing the position of the brace. A piece of galvanized iron may be tacked to the board, on which the hot iron may rest when not being used. The board is folded up against the wall and may be held in place by using the upper part of the rack for holding the portable ironing board. This rack is shown in figure 10.

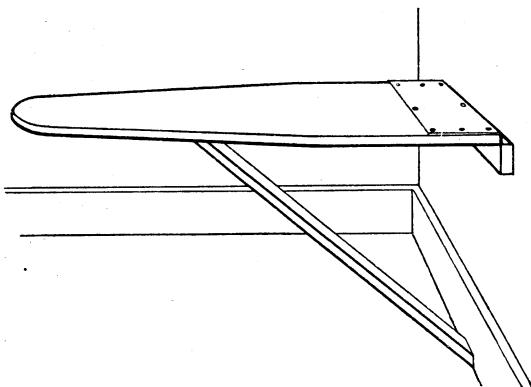

FIG. 9.—Folding ironing board.

RACK FOR PORTABLE IRONING BOARD.¹

The ironing-board rack or holder (fig. 10) may be attached to the wall or to the inside of a closet door to hold a portable ironing board when not in use. The upper part of the holder is made of $2\frac{1}{2}$ -inch material and is 5 inches in depth. It is 12 inches across the top and is shaped to fit the contour of the smaller end of the ironing board. In the center is a button which holds the top of the board in place. The button is made of metal and so shaped as to give it

¹ Designed by Mr. Paul H. Lipp, Bureau of Plant Industry, U. S. Department of Agriculture.

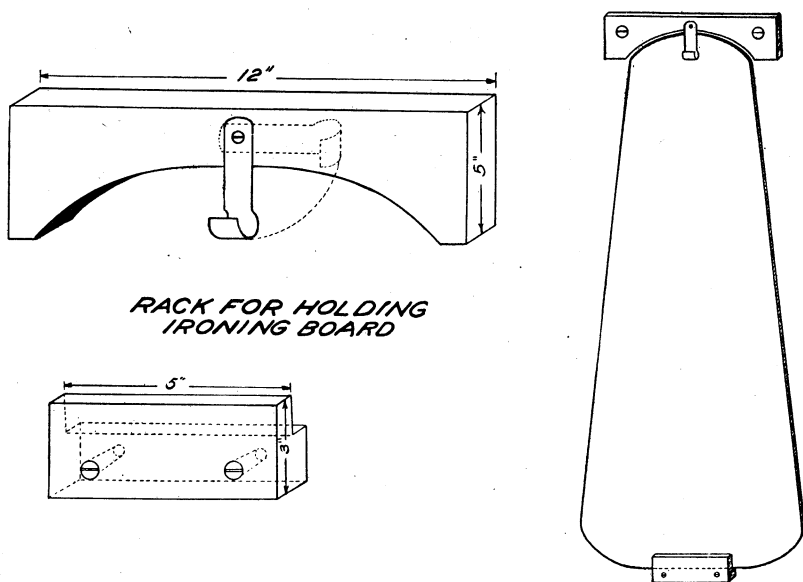

FIG. 10.—Rack for holding ironing board.

a spring and to provide a finger hold for easy movement. The upper part of the rack or holder is screwed to the wall or door.

The bottom or lower part of the rack is 5 inches wide and 3 inches in depth, and is made of $2\frac{1}{2}$ -inch material. It is rabbeted on the side next to the wall. An inch rabbet is cut in to form a rest for the ironing board. This part of the rack is fastened with two screws to the wall or door.

THE ICELESS REFRIGERATOR.¹

A very useful convenience for the farm home, where ice is not obtainable, is the iceless refrigerator (figs. 11 and 12). It will keep meats, fruits, and vegetables cool, and will extend the period for keeping milk and butter. It can also serve as a cooler for drinking water. In homes where large quantities of milk and butter are to be kept, it would be well to have one refrigerator for milk and butter, and another for other foods, as milk and butter readily absorb odors from other foods. It costs very little to build the refrigerator and nothing to operate it.

CONSTRUCTION.

A wooden frame is made with dimensions 42 by 16 by 14 inches and covered with screen wire, preferably the rustless type, which costs little more than the ordinary kind. The door is made to fit closely

¹The original model from which this iceless refrigerator has been adapted was made by Mr. Thomas Fullan, Alabama Polytechnic Institute, Auburn, Ala.

and is mounted on brass hinges, and can be fastened with a wooden latch. The bottom is fitted solid, but the top should be covered with screen wire. Adjustable shelves can be made of solid wood or strips, or sheets of galvanized metal. Shelves made of poultry netting on light wooden frames, as shown in the illustration, are probably the most desirable. These shelves rest on side braces placed at desired intervals. A bread baking pan, 14 by 16 inches, is placed on the top and the frame rests in a 17 by 18 inch pan.

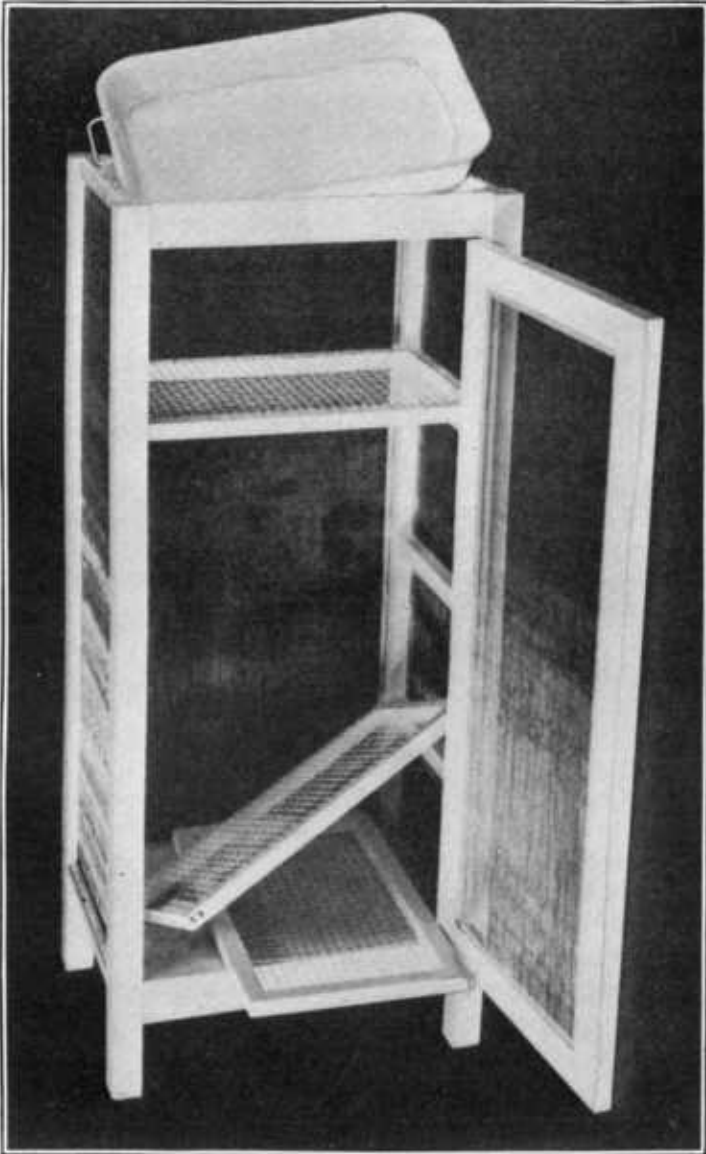

FIG. 11.—Framework of the iceless refrigerator.

All the woodwork, the shelves, and the pans should receive two coats of white paint and one or two coats of white enamel. This makes a very attractive surface and one that can be easily kept clean. The screen wire also may receive the coats of enamel, which will prevent it from rusting.

A cover of canton flannel, burlap, or duck is made to fit the frame. Put the smooth side out if canton flannel is used. It will require about three yards of material. This cover is buttoned around the top of the frame and down the side on which the door is not hinged, using buggy hooks and eyes or large-headed tacks and eyelets worked in the material. On the front side arrange the hooks on the top of the door instead of on the frame and also fasten the cover down the latch side of the door, allowing a wide hem of the material to overlap the place where the door closes. The door can then be opened without unbuttoning the cover. The bottom of the cover should extend down into the lower pan. Four double strips, which taper to 8 or 10 inches in width, are sewed to the upper part of the cover. These strips form wicks that dip over into the upper pan.

The dimensions given make a refrigerator of very convenient size for household use and one with efficient evaporating surface, but it is not necessary to follow strictly these dimensions. If a larger capacity is desired, the height of the refrigerator can be increased.

OPERATION.

The operation of the refrigerator shown in the illustrations is as simple as its construction. The lowering of the temperature of the inside of the refrigerator depends upon the evaporation of water. To change water from a liquid to a vapor, or to bring about evaporation, requires heat. As evaporation takes place heat is taken from the inside of the refrigerator, thereby lowering the temperature of the inside and the contents.

Keep the upper pan filled with water. The water is drawn by capillary attraction through the wicks and saturates the cover. Capillary action starts more readily if the cover is first dampened by dipping it into water or throwing water upon it with the hand. The greater the rate of evaporation the lower the temperature which can be secured; therefore the refrigerator works best when rapid evaporation takes place. When the refrigerator is placed in a shady place in a strong breeze and the air is warm and dry, evaporation takes place continuously and rapidly and the temperature inside the refrigerator is reduced. Under ideal conditions the temperature has been known to be reduced to 50° F. When it is damp, and the air is full of moisture, the refrigerator will not work as well, since there is not enough evaporation. More water will find its way to the lower pan, but it will be drawn up into the covering by capillary attraction when the air again becomes drier.

CARE OF REFRIGERATOR.

The refrigerator should be regularly cleaned and sunned. If the framework, shelves, and pans are white enameled they can more easily be kept in a sanitary condition. It is well to have two covers, so that a fresh one can be used each week and the soiled one washed and sunned.

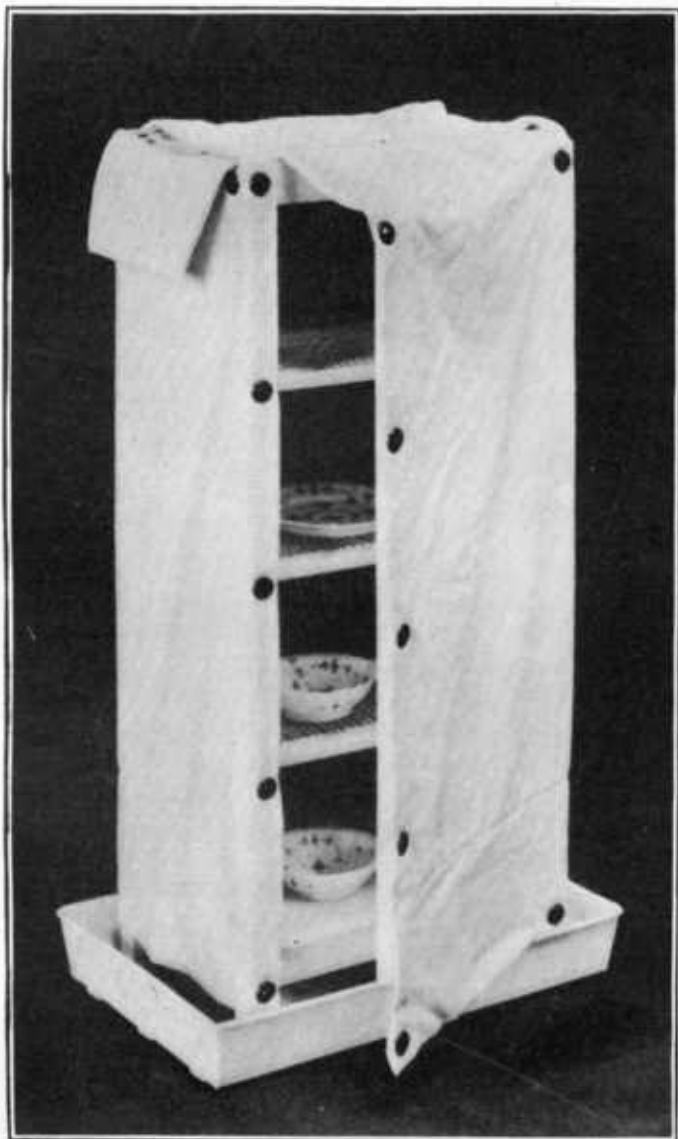

FIG. 12.—The completed iceless refrigerator.

THE COLD BOX.

For keeping food during cool weather a cold box will be found very satisfactory. An ordinary light box can be used or one can be easily and cheaply made for the purpose. The box is fitted to the

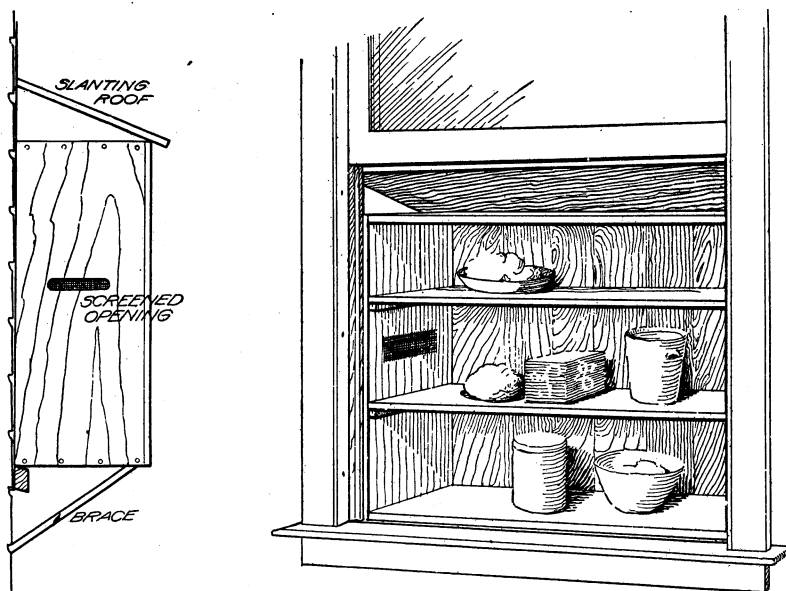

FIG. 13.—Cold box.

outside of the kitchen or pantry window. The north exposure is the coolest location. Raising the window gives access to the cold box. By this arrangement the light from the upper half of the window is still available. (Fig. 13.)

The window sill is extended by a shelf which is supported by wooden brackets. The cold box rests on the window sill and the extended shelf, and is fastened to the window casing by screws or nails near the top and bottom of each end of the box. During warm weather, when the box is not in use, it may be removed if desired. The box should have a sloping top to shed the rain. Holes for ventilation are made in the ends of the box and screened. Shelves in the box may be made of heavy screening or poultry netting or of wood. They rest on cleats fastened to the sides of the box.

Food placed in the box should be covered so as to protect it from dust.

EQUIPMENT FOR HOME BUTTER MAKING.

There is no secret in making good butter. With proper care and attention to details good butter can be made in any farm home. The quality of the butter is dependent upon the intelligent use of equip-

ment rather than the kind, although suitable equipment is time-saving and labor-saving and can be purchased and made at a nominal cost. (Fig. 14.)

Milk vessels should be of high-grade tin with all joints and seams smoothly soldered so that there will be no crevices in which dirt may accumulate. A convenient milk can to use is the 3-gallon shotgun can. It should have a smooth, heavily tinned interior, to prevent rusting and difficulty in cleaning. All butter-making equipment should be thoroughly scrubbed with a brush in hot water containing sal-soda or washing powders. Never use a dish cloth or soap. Inexpensive stiff fiber scrub brushes or vegetable brushes can be purchased at any grocery or hardware store. After equipment is washed it should be scalded or steamed. A homemade sterilizer will be found most convenient and helpful. (See Farmers' Bulletin 748.)

A medium-sized dipper strainer with a fine-meshed gauze has been found to be very satisfactory. It should be smooth and free from seams. Butter should not be touched or handled with the bare hands. It injures the quality of the butter and is very insanitary. Wooden ladles can be easily whittled from maple, ash, or poplar or brought at a small cost. A thermometer is absolutely essential to successful butter making. Controlling temperatures is second only to keeping equipment clean. A floating dairy thermometer can be ordered from any dairy supply company.

In making butter the salt should be uniformly distributed and the granules pressed together into a close-grained mass and the surplus water worked out. This can be most easily accomplished by use of

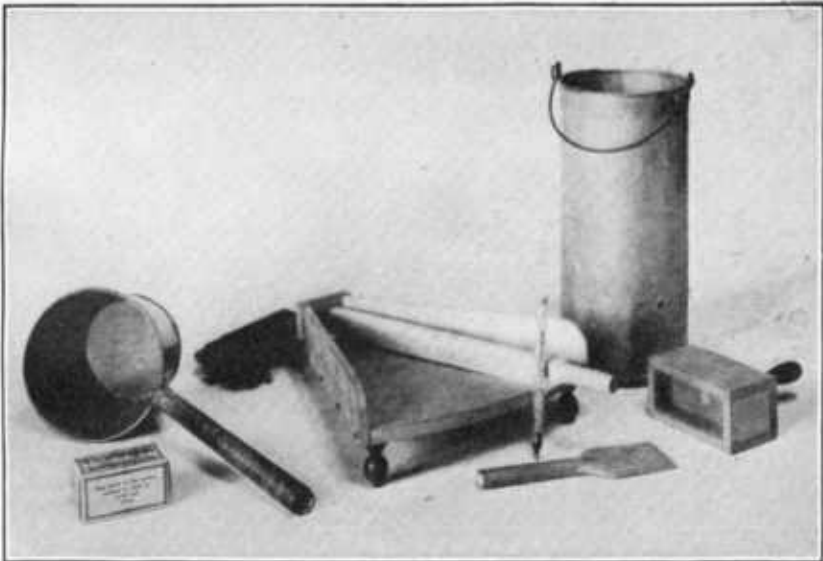

FIG. 14.—Equipment for home butter making.

a V-shaped lever butter worker made of 1-inch material. This worker is made of maple, ash, or poplar, the material of which all wooden butter equipment is made. Any woods from which odors or flavors might be absorbed by the butter should not be used.

For the amount of butter made in most farm homes a butter worker 18 inches long, 16 inches at the wide end and $2\frac{1}{2}$ inches at the narrow end is a convenient size. The sides are 3 inches wide and are screwed to the bottom. The corrugated roller having six or eight sides is 24 inches long. One end of the roller is shaped to fit a small hole made in the piece across the narrow end of the worker. This end piece is of a width that leaves a slot just above the bottom of the worker which allows the water to drain off into a pan as the roller is pressed firmly backward and forward over the butter. The worker rests on three knobs or supports. The two knobs at the wider end are $3\frac{1}{2}$ inches high, while the knob at the narrow end is $2\frac{1}{2}$ inches. (Fig. 14.)

The most popular, convenient, and attractive butter mold is the brick-shaped or square-cornered mold. This mold can be made of $\frac{5}{8}$ -inch material. The mold most commonly used is $4\frac{5}{8}$ by $2\frac{1}{2}$ by $2\frac{3}{8}$ inches. An inch hole is bored through the center of the top and through the center of a plunger which fits closely into the mold. Through the hole in the top of the mold is inserted the round handle which screws into the hole in the plunger. Most satisfactory molds of this type can be found on the market.

When butter is to be sold, parchment papers 8 by 11 inches should always be used to wrap the pound print. Also neat and attractive

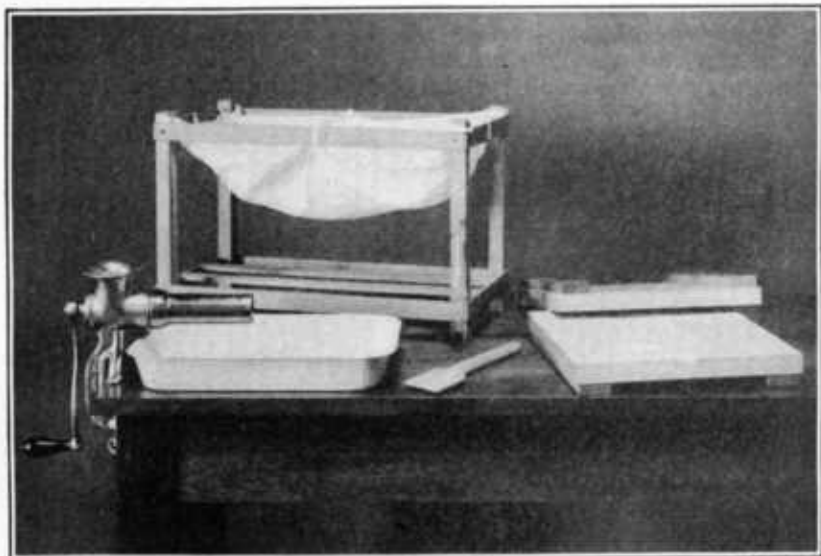

FIG. 15.—Cheese-making equipment.

paper butter cartons should be used when butter is put on the market. It will bring a better price if packed well.

To make the butter-making equipment complete, a barrel churn should be added. The barrel churn is generally recognized as the most convenient and efficient kind of churn in use. When an extra large quantity of milk is handled it pays to use a cream separator. A separator insures more and better butter.

CHEESE-MAKING EQUIPMENT.

Cottage, Neufchatel, plain cream, and pimiento cream cheese can be made in the farm home where a surplus supply of milk is available. Cheese is not only a very valuable food in the family diet, but if a first-class product is produced a good market can usually be found for it. The equipment for making cheese is very simple and most of it could be made at home.

The rack for draining the cheese is 16 inches deep, 12 inches wide, and 24 inches long, and is made of pine. The bottom slats which hold the pan under the draining cloth fit into notches made in the lower side strips and can easily be removed when the rack is washed. The corner posts extend $\frac{3}{4}$ inch above the strips at the top and the corner loops of the muslin or cheesecloth drain cloth are looped over the posts. A similar rack, as described, could be made out of an orange or vegetable crate. (Fig. 15.)

The press is made of two poplar or maple boards $1\frac{1}{2}$ inches thick and $14\frac{1}{2}$ inches square. Strips of wood $1\frac{3}{4}$ inches wide are nailed or screwed on the back of each board to prevent them from warping. The boards are planed and sandpapered until perfectly smooth. The lower board has a circular groove which has an outlet through which the whey drains as it is pressed out of the curd.

A wooden paddle, a dairy thermometer, and a food chopper or sausage grinder with molding tube complete the necessary equipment. The molding tube or cylinder could be made by a tinsmith or can be ordered through a hardware dealer. The paddle can easily be made. The molding tube or stuffing attachment which is attached to the food chopper molds the Neufchatel and cream cheese into attractive and convenient molds for the market. The cheese can also be packed into small glass jars by placing the opening of the jar over the end of the tube through which the cheese is forced. The pimiento cream cheese is always put on the market in small glass jars.

THE SHOWER BATH.

Better bathing facilities are often needed in homes where bathrooms are not found. A cheap and convenient shower bath can be easily made and used in the kitchen or on the back porch. (Fig. 16.)

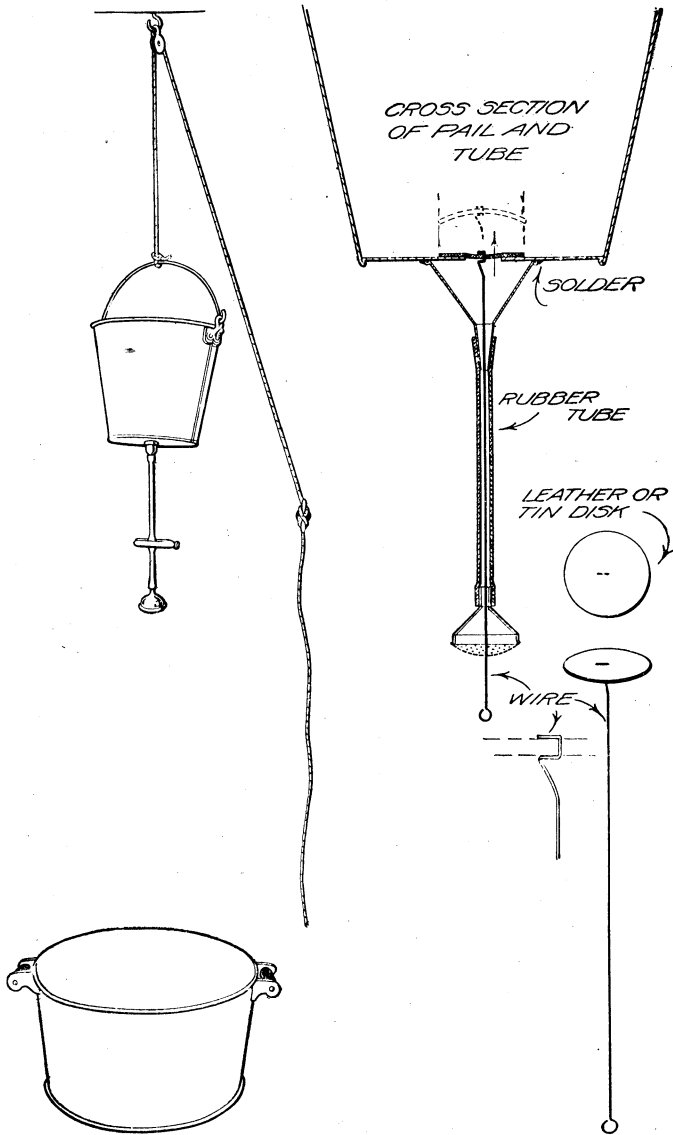

FIG. 16.—The shower bath.

The shower bath is especially useful in homes where there are children.

A hole is cut in the bottom of a 4-gallon bucket and a piece of pipe 2 inches long soldered in the opening. Rubber tubing 4 to 6 feet long is attached to the pipe and a nozzle is fitted on the end of the rubber tubing. A sprinkler from a watering can may be used instead of the nozzle. The bucket can be raised or lowered to suit the convenience of the person taking the bath by a rope fastened to the

handle of the bucket and run through a pulley which is fastened with a staple to a joist in the ceiling. The end of the rope is looped over a hook, which is driven securely into the window or door facing, or into the studding in the wall.

A clothespin closed over the rubber tubing serves as a stopcock to cut off the water as desired. The shower can be better regulated by using a device such as is shown in the illustration. The end of a piece of No. 12 or 14 wire is fastened to a disk of leather or tin, or a cap of a tin can, by making a hole in the material used, running the wire through and looping the end. This disk is placed over the hole in the bottom of the bucket and the attached wire extends through the rubber tubing and the nozzle. The shower can be regulated by the disk being raised and lowered by means of the wire. The weight of the water in the bucket on the disk will form a sufficient seal when no flow is desired.

A large tub is placed under the shower, in which the bather stands. The tub and bucket are more attractive if given two coats of white paint and one coat of white enamel.

WELL PROTECTION AND INEXPENSIVE WATERWORKS FOR A FARM KITCHEN.¹

The three important principles to consider in the subject of water supply for the farm home are: (1) It is necessary to have clean water, (2) there should be convenient and serviceable equipment to furnish running water in the house, and (3) this convenient supply of safe water should be secured with economy.

The first and most important consideration is to get a supply of clean water. By clean water is meant water which is both clear and pure. Good farm water supplies are usually obtained from wells, springs, and cisterns. Water from wells on farms is frequently contaminated and contains the source of disease. Contaminated water may be the cause of outbreaks of typhoid fever, dysentery, and other intestinal disorders among members of the family.

Both shallow dug wells and deep bored wells may be polluted by the entrance of filth, vermin, and unclean water at the top and also by seepage of contaminated soil water. These are the results of poor location of the well, generally unclean surroundings, open or loose well curbs, the absence of a well lining, or the presence of a poor well lining. The first step in securing a clean water supply is to remove all sources of possible contamination. Among the worst of these are the open privy vault, the leaching cesspool, and barnyard filth. A well in ordinary pervious soil, located lower than and within 100 feet of any of these, is almost certain to be contaminated.

¹ Information and plans furnished by Mr. R. W. Trullinger, States Relations Service, United States Department of Agriculture.

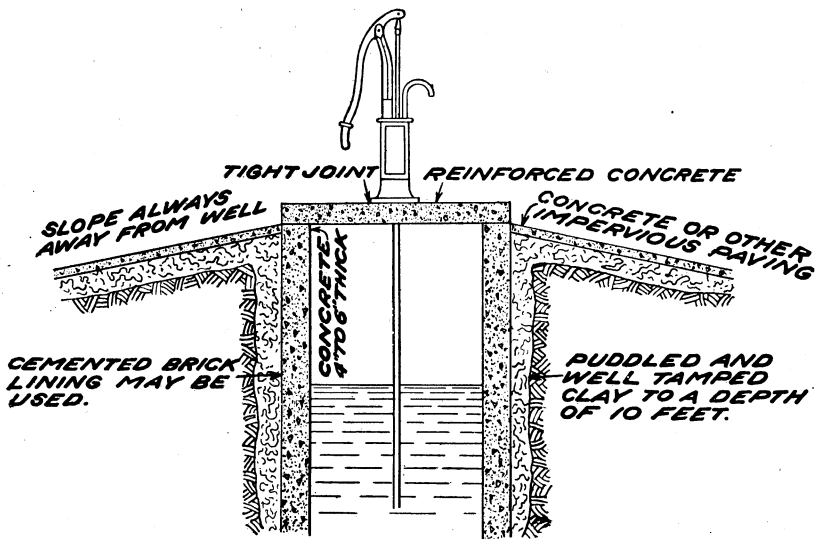

Fig. 17.—Dug well, concrete or cemented-brick lining.

The well itself should be located as high as possible with regard to buildings, stock pens, and chicken yards, and as far away from all sources of contamination as convenience and local surroundings will permit. The final safeguards to a well-water supply are to provide an impervious lining of concrete, cemented bricks, cemented tile, or iron casing, and to provide a water-tight curb, not only to keep out surface wash, animals, and vermin, but to prevent the pump drip and dirt from shoes and buckets from entering the well. (Figs. 17, 18, 19, 20.)

The same precautions with reference to the entrance of filth and polluted water from the surface apply to underground cisterns.

Springs are subject to contamination from the same sources as wells, although more often contaminated by surface wash and because animals have access to them. They can be protected by fencing in from animals, walling in the spring to form a covered and water-tight reservoir, and by keeping the surroundings clean. Spring water should be kept under close observation for any signs of surface pollution, especially those springs occurring in limestone regions.

Having secured a clean water supply, the next step is to provide equipment to furnish running water in the kitchen at the turning of a faucet or by merely pumping.

If the well or cistern is located close to the house, one of the simplest and cheapest methods of obtaining running water in the kitchen in the warmer climates is to place a covered barrel or other supply tank on a shelf outside the kitchen wall and in such a position that it can be filled from the pump through a hose, as desired. A pipe

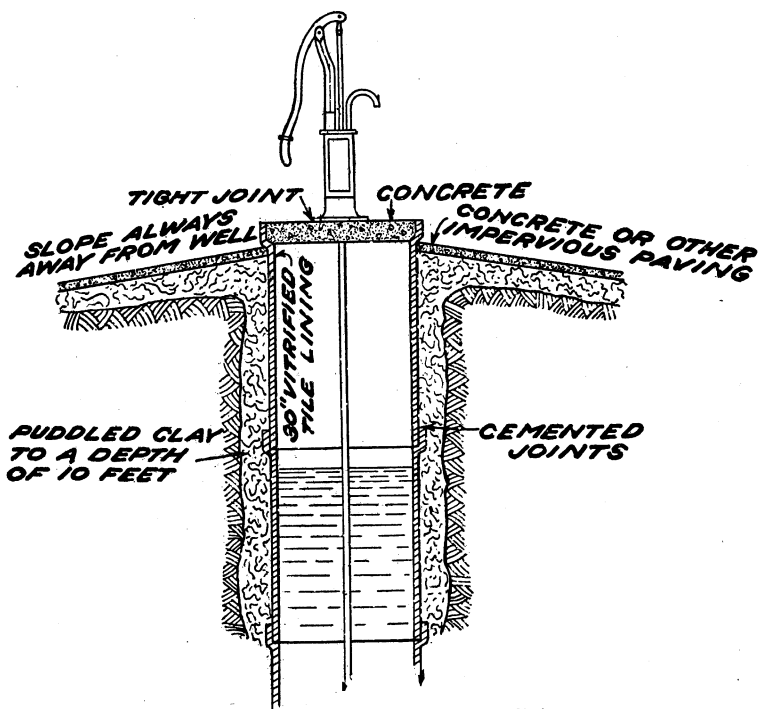

Fig. 18.—Dug well, vitrified tile lining.

attached to the bottom of the barrel or tank and passing through the wall has attached to it a faucet over a sink in the kitchen. The hose is detachable and can be removed from the pump when not in use. (Fig. 21.)

The sink is connected by lead pipe through a trap to a drain, which should consist of cast iron soil pipe when it is used anywhere in the immediate neighborhood of the well or cistern. Do not under any consideration use cemented tile for this purpose within 30 feet of any source of water supply. When far enough away from the house or well this drain can empty into open jointed drain tile which may be placed in the garden soil or any other pervious soil, thus disposing of the waste water by absorption. The disposal tile should have a fall not to exceed 1 inch in 50 feet, else the water will rush to the lower end and water-log the soil. In very porous or sand soils 1 foot of 3 or 4 inch tile per gallon of discharge per day is sufficient. In heavier loam or clay soils 2 feet of tile are necessary and sometimes more for every gallon. Aeration of heavy soil can be brought about by the use of coarse cinders or gravel laid in the bottom of the tile ditch.

Where there is danger of freezing or where the well is very close to the house, about the simplest and cheapest method is to place a pitcher pump or force pump over a sink in the kitchen. The suc-

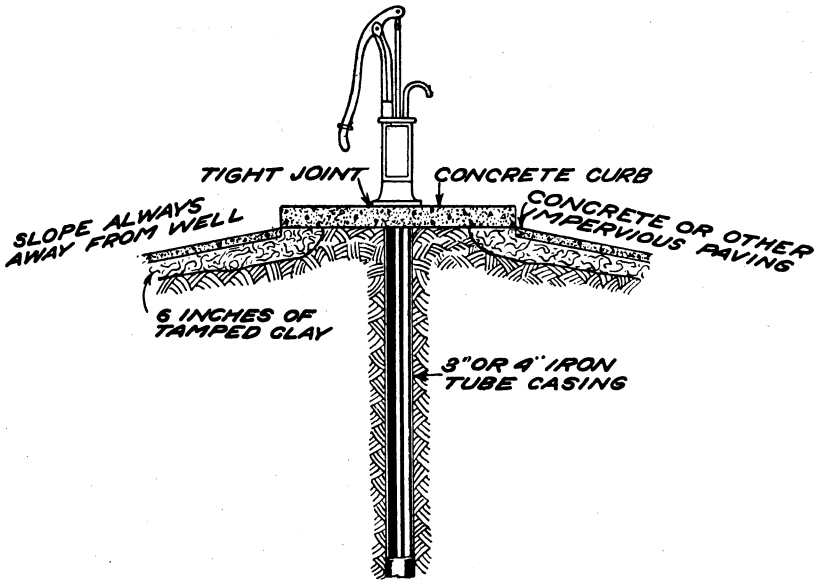

FIG. 19.—Bored well.

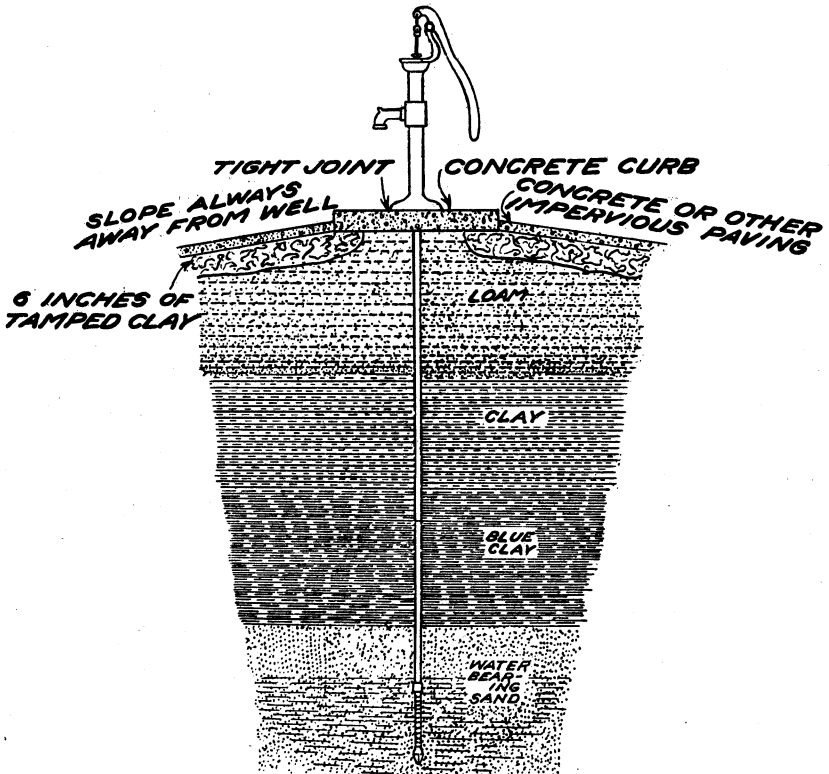

FIG. 20.—Driven well.

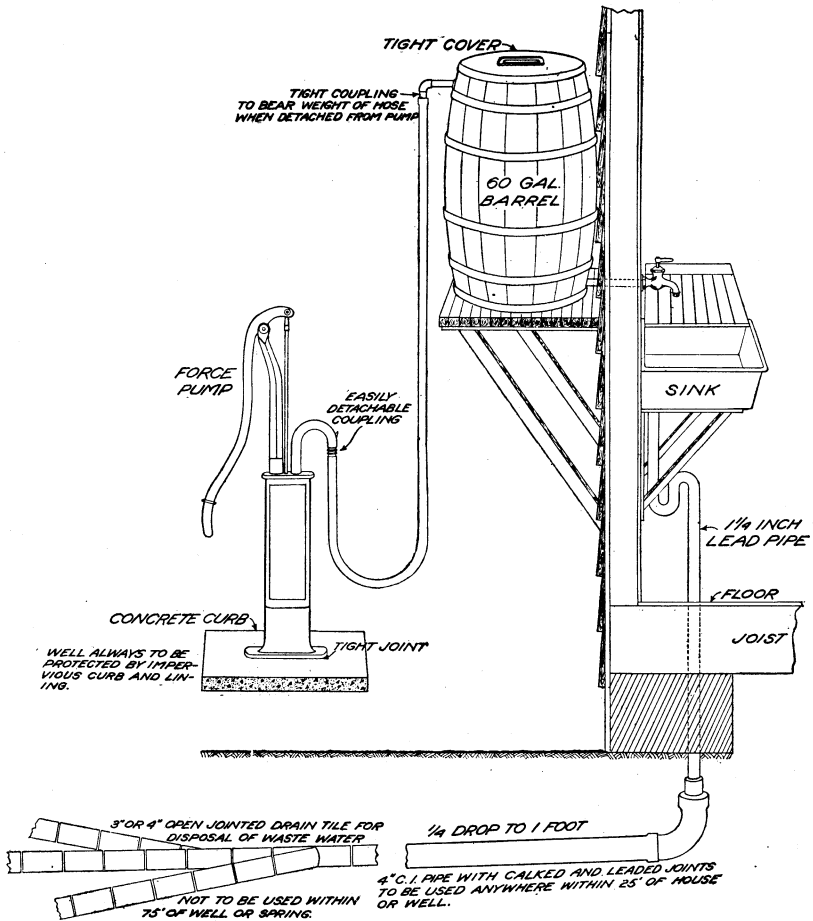

FIG. 21.—Simple water-supply system for farm kitchen.

tion pipe of the pump may be attached to the well or cistern and water obtained when desired merely by pumping. This is provided the vertical distance from the pump to the water in the well does not exceed 20 feet, as under ordinary circumstances a pump will lift water satisfactorily by suction only to about that height. The allowable distance from the well to the pump for this arrangement will vary with local conditions, cases having been noted in which the distance was as far as 200 feet. As water meets with resistance in pipes, due to friction, elbows, and bends, it is well to take off about 2 feet from the allowable vertical pumping lift for every 100 feet the water is drawn horizontally.

From the standpoint of economy, which is the third consideration, all local conditions which would have a bearing on obtaining clean water and putting it into the house with convenient and serviceable

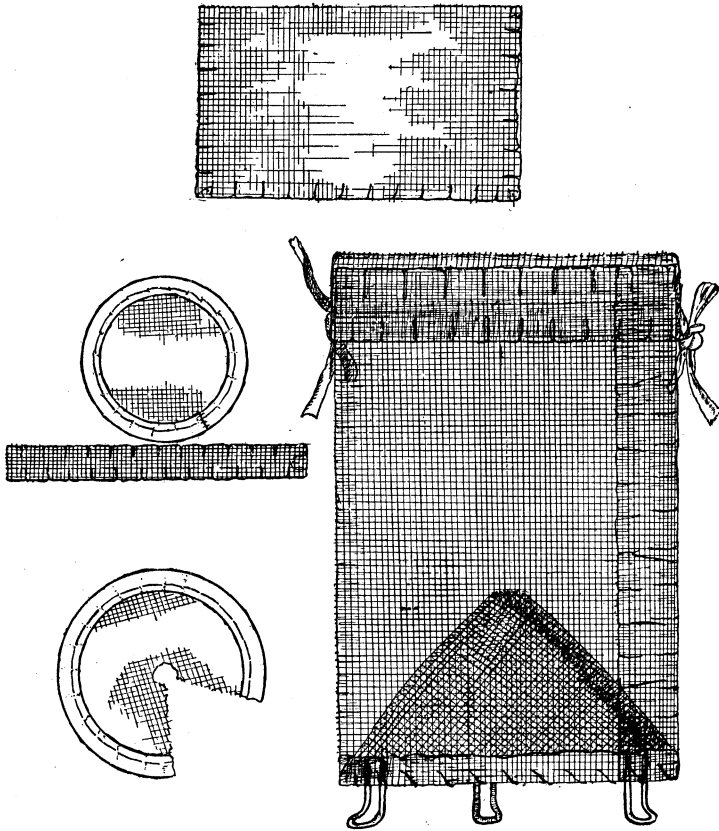

FIG. 22.—Fly trap.

equipment should be determined. No matter how cheap the system, if the water is not clean or the equipment is not serviceable or convenient, the investment is a poor one. Plan first of all to do the necessary work to give absolutely clean surroundings; next secure the proper material to protect the well. By inquiry as to local prices of material and labor the cash outlay needed can be easily determined. In the majority of cases it will be found that the well or spring can be protected by the use of material available on the farm, such as old bricks, stones, etc., with a cash outlay for little except cement, or in case of a bored well, for iron casing. The same principle should be applied in planning the water-supply equipment. All material and labor available on the farm or in the locality should first be utilized and only such cash expenditure should be made as is necessary to make the system complete, serviceable, and convenient. It will be found on a great many farms that the two systems briefly outlined can be obtained for a moderate outlay of cash for the pump, sink, pipe, and fittings. In many cases the pump is already installed.

Thus by the proper utilization of material and labor available on the farm and by a small cash outlay, cleanliness, convenience, comfort, and economy in the water supply can be obtained, the value of which can not be estimated.

FLY TRAP.

Fly control should begin at the breeding places. All refuse or other substances in which flies may breed should be disposed of immediately. Fly traps should be placed around the house and stable and in places frequented by flies, so as to catch them whenever they appear. It is necessary to use bait to attract the flies. After they are caught they may be destroyed by pouring hot water over the trap and then burning the flies.

Any woman, without hammer or saw, can easily make the kind of fly trap shown in figure 22. The dimensions will depend upon the size of trap desired. Nonrustable screen wire should be used. A straight rectangular piece of screen wire is used for the cylinder or body of the trap. This is blanket stitched with heavy thread to prevent the wire from raveling. The cone is made of a circular piece of screen wire from which a sector or V-shaped piece has been cut, and a small hole is cut at the center which permits the entrance of the flies. A binding of heavy muslin or denim is sewed around the edge of the cone. The cone is slipped up into the cylinder. It is made large enough to fit tightly. It is made secure by the bound edge being sewed to the cylinder. The top of the trap is made of a circular piece of wire which exactly fits the top of the cylinder. On the edge of this piece is sewed a binding. On this edge is sewed a straight piece of wire 2 inches wide which forms the rim of the top of the trap. This top fits on the cylinder snugly and is held in place by pieces of tape. The legs of the trap are made of bended wire.

The trap should be thoroughly scalded every few days. The following may be used for baits—sour or skim milk to which a little sugar has been

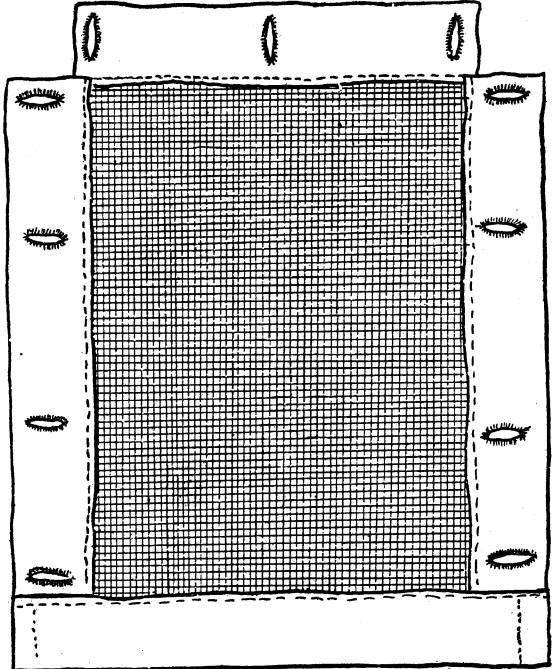

FIG. 23.—Window screen.

added; meat or fish scraps; bread and milk to which sugar has been added; and sugar, vinegar, and water.

WINDOW SCREEN.

All outside doors and windows should be screened. It will be economy to buy the screen doors. For both doors and windows use nonrustable screen wire.

A very cheap, convenient, and easily made window screen is shown in figure 23. Any woman can make this screen fit any window. Often in old houses window frames have warped and it is hard to make screen frames fit the windows.

Heavy denim or jeans or any other heavy material, of dark color, is cut into strips 4 inches wide. This is sewed around the edge of the screen, leaving about 2 inches of the doubled material as strips for eyelets. Eyelets are worked across the top and down the side strips. Small tacks are driven in the lower casing of the top window and down the sides of the window frames. The eyelets in the window screen are fastened over the heads of the tacks and thus the screen is held in place. This screen can only be used when upper windows can not be lowered and it can be removed easily when not needed.

COOKSTOVE DRIER OR EVAPORATOR.

Vegetables and fruits can be dried in an oven, in trays or racks over the kitchen stove, or in a specially constructed drier. There are small driers on the market which give satisfactory results. The small cookstove driers or evaporators are small oven-like structures, usually made of galvanized sheet iron, or of wood and galvanized iron. They are of such a size that they can be placed on the top of an ordinary wood or coal range, or a kerosene stove. These driers hold a series of small trays on which fruits or vegetables are placed after being prepared for drying. Portable outdoor evaporators are especially convenient when it is desired to dry as much as 10 bushels of fruit or vegetables per day. They are usually constructed of wood except the parts in direct contact with the heater. The homemade drier kiln used in some sections of the country can be cheaply and easily made of brick and stone.

A drier that can be used on a wood or coal range or a kerosene stove can be easily and cheaply made. (Fig. 24.) Dimensions: Base, 24 by 16 inches; height, 36 inches (including the height of the base). The drier can be made smaller if desired. A base 6 inches high is made of galvanized sheet iron. This base flares slightly toward the bottom and has two small openings for ventilation in each of the four sides. On the base rests a boxlike frame made of 1 or 1½ inch strips of wood. The two sides are braced with 1¼-inch strips which serve as cleats on which the trays in the drier rest. These are placed at intervals of 3 inches. The frame is covered with tin or galvanized sheet iron, which is tacked to the wooden strips of the frame. Thin strips of wood may be used instead of tin or sheet iron. The door is fitted on small hinges and fastened with a thumb latch. It opens wide so that the trays can be easily removed. The bottom in the drier is made of a piece of perforated galvanized sheet iron. Two inches above the bottom is placed a solid sheet of galvanized iron, 3 inches less in length and width than the bottom. This sheet rests on two wires fastened to the sides of the drier. This prevents the direct heat from



FIG. 24.—Cookstove drier or evaporator.

coming in contact with the product and serves as a radiator to spread the heat more evenly.

The first tray is placed 3 inches above the radiator. The trays rest on the cleats 3 inches apart. A drier of the given dimensions will hold eight trays. The frame of the tray is made of 1-inch strips on which is tacked galvanized screen wire, which forms the bottom of the tray. The tray is 21 by 15 inches, making it 3 inches less in depth than the drier. The lowest tray when placed in the drier is pushed to the back, leaving the 3-inch space in front. The next tray is placed even with the front, leaving a 3-inch space in the back. The other trays alternate in the same way. A ventilator opening is left in the top of the drier through which the moist air may pass away.

The principle of construction is that currents of heated air pass over the product as well as up through it, gathering the moisture and passing away. The current of air induces a more rapid and uniform drying. The upper trays can be shifted to the lower part of the drier and the lower trays to the upper part as drying proceeds, so as to dry products uniformly throughout.

THE CLEANING CLOSET.

Entrance of dust and dirt into a house is unavoidable, and the housekeeper is compelled to spend some of her time and energy in the daily cleaning. Through the use of better equipment and more systematic planning she is able to do the cleaning more easily and quickly. It is well to have a special place where cleaning utensils may be kept in the best condition and ready for instant use. Much time and energy is spent in collecting the utensils needed for cleaning.

A closet, cupboard, or wardrobe in the kitchen is the best place for keeping the cleaning utensils. A backstair closet is also a good place. One end of a back porch may be inclosed and used for such a purpose. The closet should have plenty of hooks and racks for utensils and a shelf for cleaning materials.

The housekeeper should choose utensils according to her own needs and according to the requirements of her house. Those suggested below are inexpensive and will help to lighten the work of cleaning:

Bucket with wringer for mopping.

A piece of inch board 15 inches square with rollers makes a convenient platform on which to set the mop bucket, and permits it to be moved easily without lifting.

Wall mop made by tying a bag made of wool or cotton cloth over an ordinary broom.

A broom, with a hook screwed in the end of the handle by which it can be hung up.

A long-handled dustpan.

Several brushes for cleaning purposes.

Cheesecloth, worn silk, and flannelette for dusters.

Dusters may be made by dipping pieces of cheesecloth in 2 quarts of warm water to which one-half cup of kerosene has been added. These cloths should be kept away from the stove or lighted lamp, as they are inflammable.

A blackboard eraser covered with flannelette for stove polishing.

An oiled floor mop to use on oiled or polished floors. Several makes can be found on the market, or one may be made of old stockings or any discarded woolen or flannelette material. The material is cut into 1-inch strips and sewed across the middle to a foundation of heavy cloth. This is fastened to an old broom handle or used in a clamp mop handle. The mop is dipped into a solution made of one-half cup melted paraffin and one cup kerosene and allowed to dry. To keep it moist, it is rolled tight and kept in a paper bag, away from stove or lamp.

A carpet sweeper or a vacuum cleaner should be used in the daily cleaning of the carpets and rugs. A vacuum cleaner operated by hand or electric power removes practically all the dust and dirt from carpets and rugs in a dustless manner.

PUBLICATIONS OF THE U. S. DEPARTMENT OF AGRICULTURE OF INTEREST IN CONNECTION WITH THIS BULLETIN.

AVAILABLE FOR FREE DISTRIBUTION BY THE DEPARTMENT.

Farm Kitchen as a Workshop. (Farmers' Bulletin 607.)

Conveniences for The Farm Home. (Farmers' Bulletin 270.)

Homemade Fireless Cookers and Their Use. (Farmers' Bulletin 771.)

Home and Community Drying of Fruits and Vegetables. (Farmers' Bulletin 841.)

Plan for a Small Dairy House. (Farmers' Bulletin 689.)

Production of Clean Milk. (Farmers' Bulletin 602.)

A Simple Steam Sterilizer for Farm Dairy Utensils. (Farmers' Bulletin 748.)

Fly Traps and Their Operation. (Farmers' Bulletin 734.)

Sanitary Privy. (Farmers' Bulletin 463.)

The Use of Concrete on the Farm. (Farmers' Bulletin 461.)

The Use of Paint on the Farm. (Farmers' Bulletin 474.)

Clean Water and How to Get It on the Farm. (1914 Yearbook Separate 634.)

Water Supply, Plumbing, and Sewage Disposal for Country Homes. (Department Bulletin 57.)