

航海計器附圖

神戸高等商船學校

0 1 2 3 4 5 6 7 8 9 10 11 12 13 14 15 16 17 18 19 20 21 22 23 24 25

始

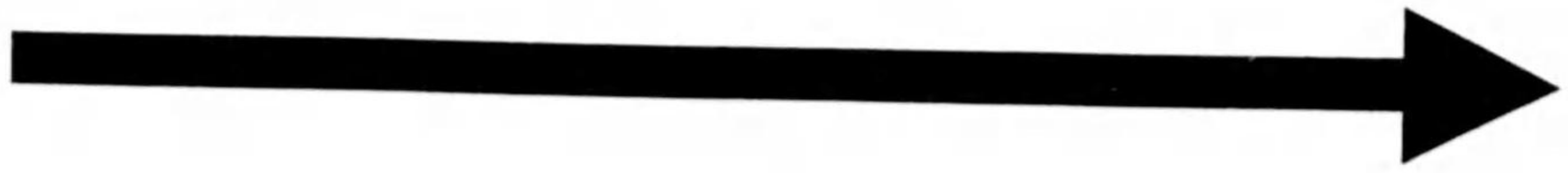

980
13

558.2
K013



航海計器附圖



Fig. 1.

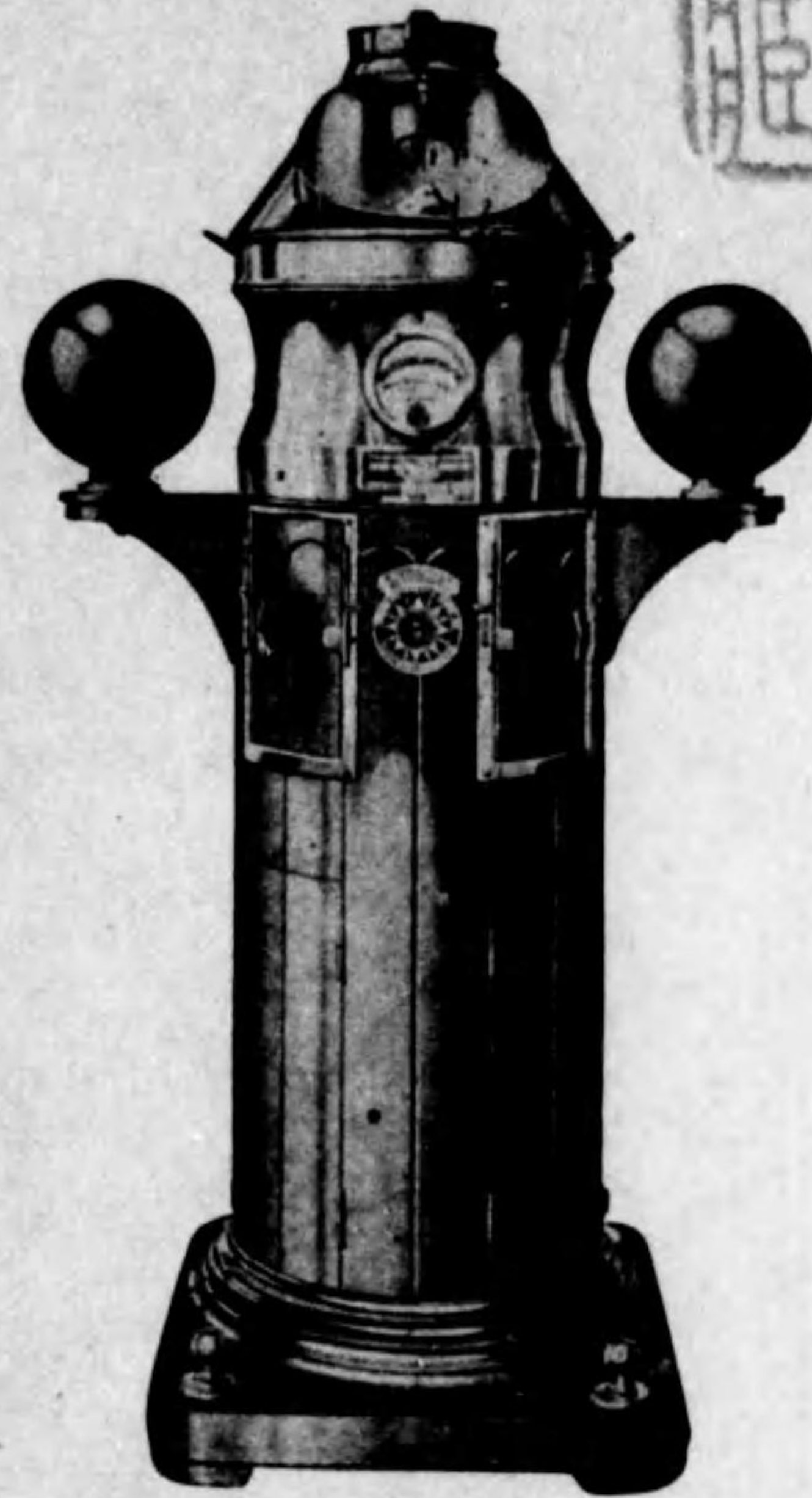

Fig. 3.

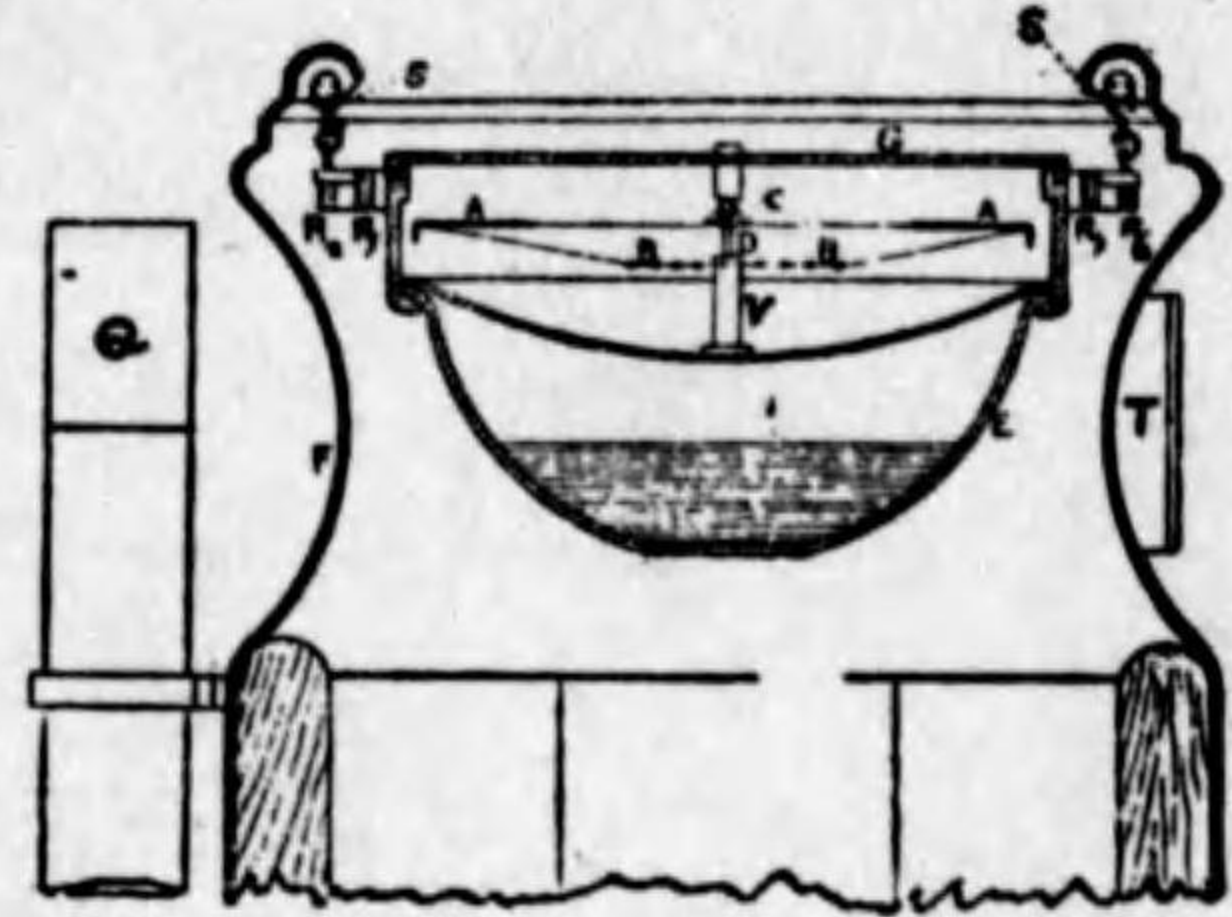

Fig. 2.



Fig. 4.

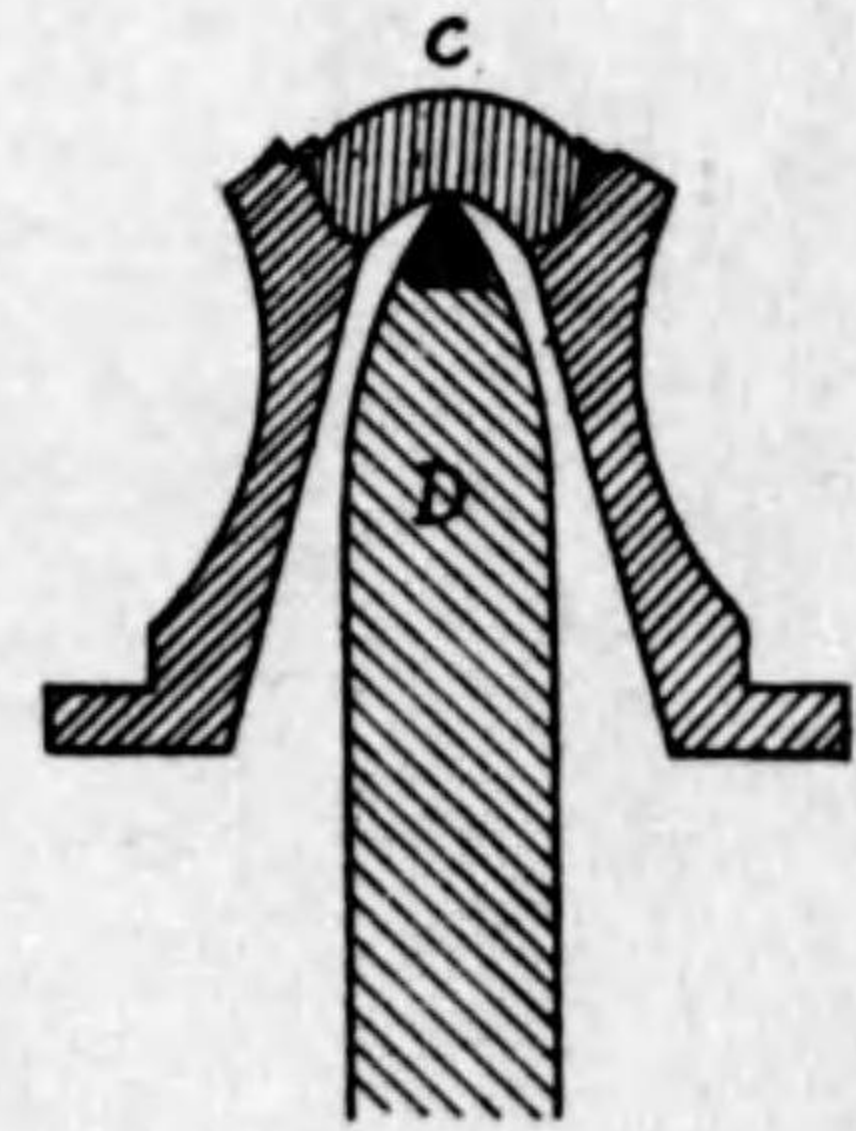
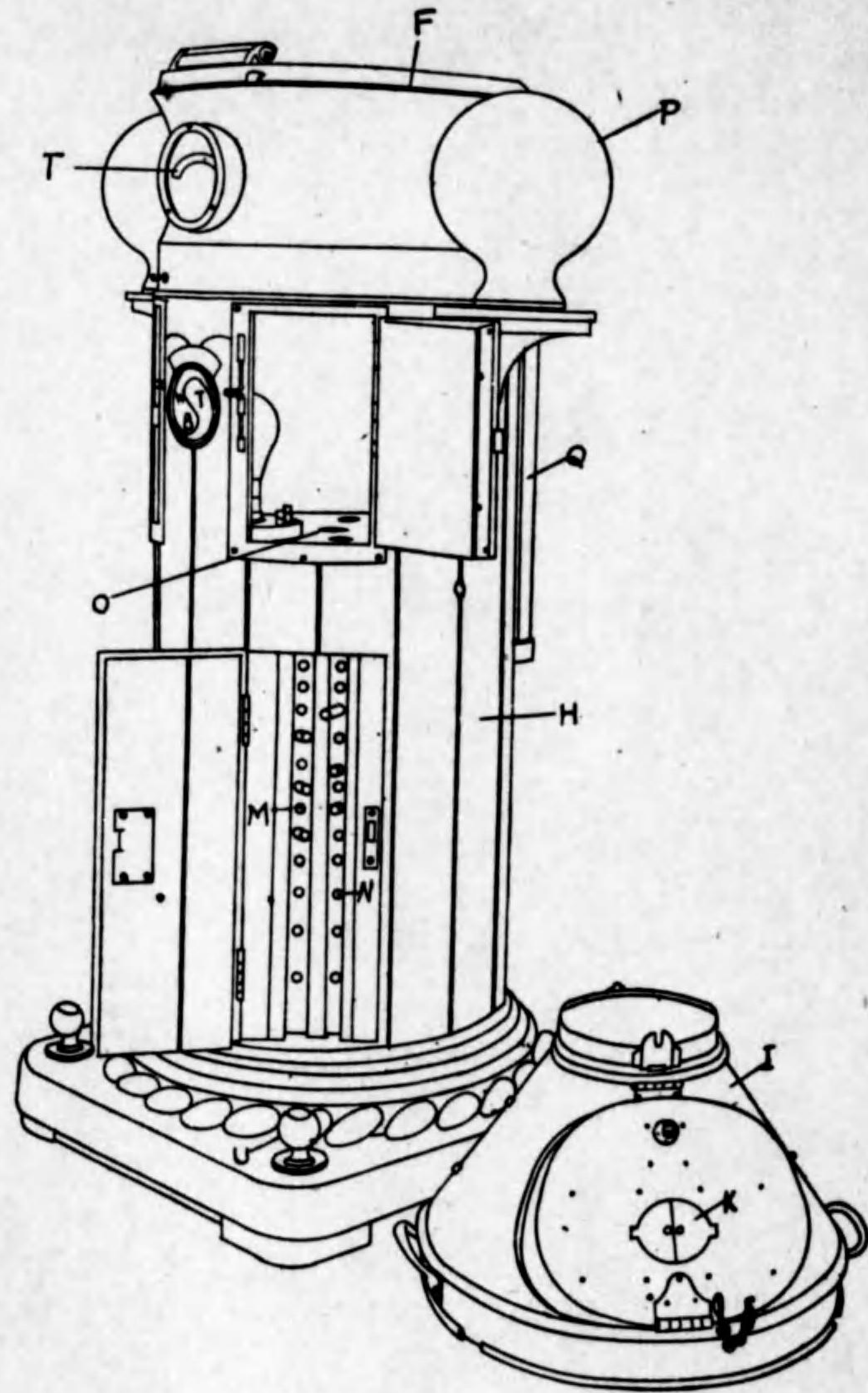

Fig. 5.



980
1E

Fig. 6.

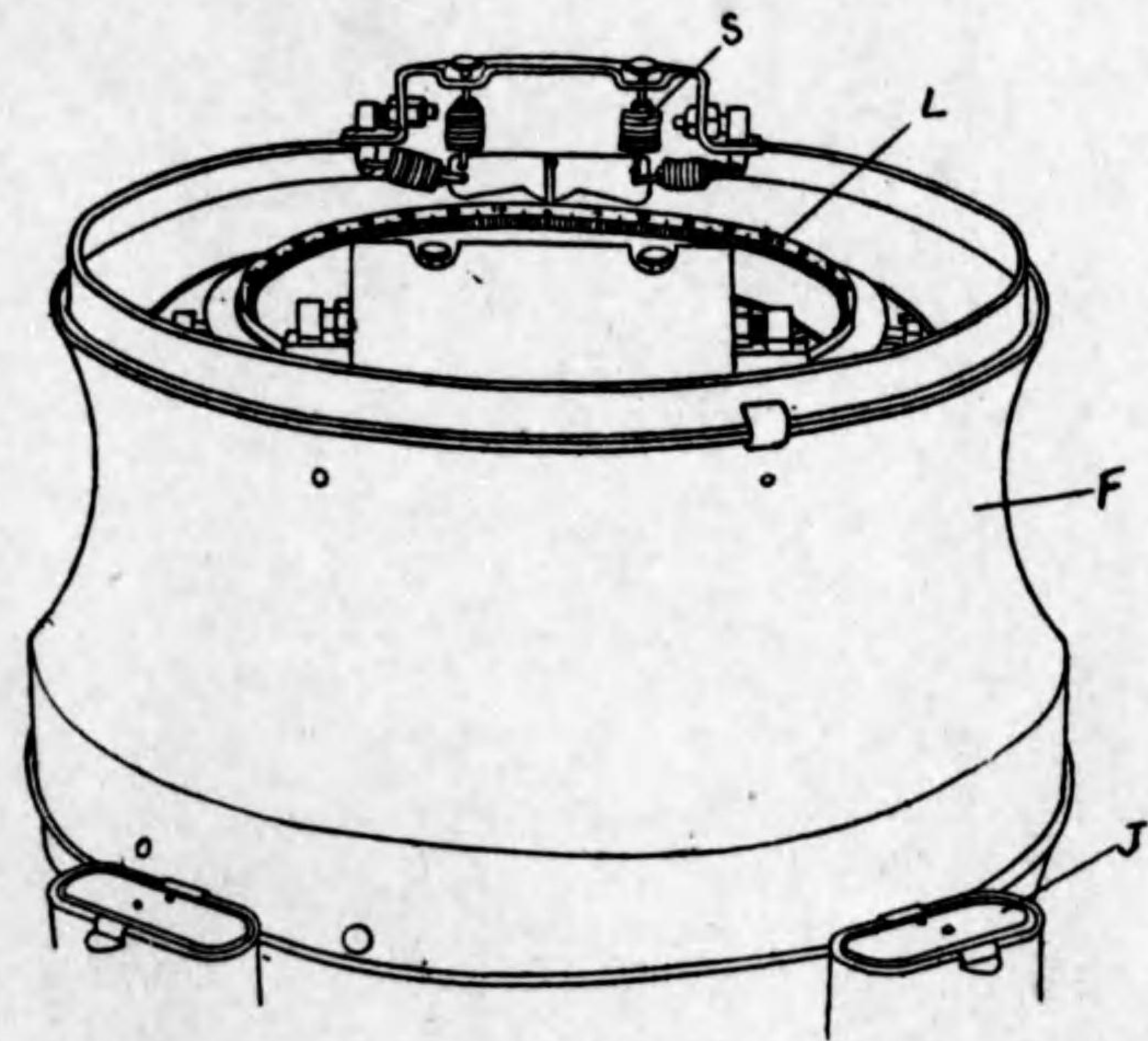

Fig. 7.



Fig. 8.



Fig. 9.

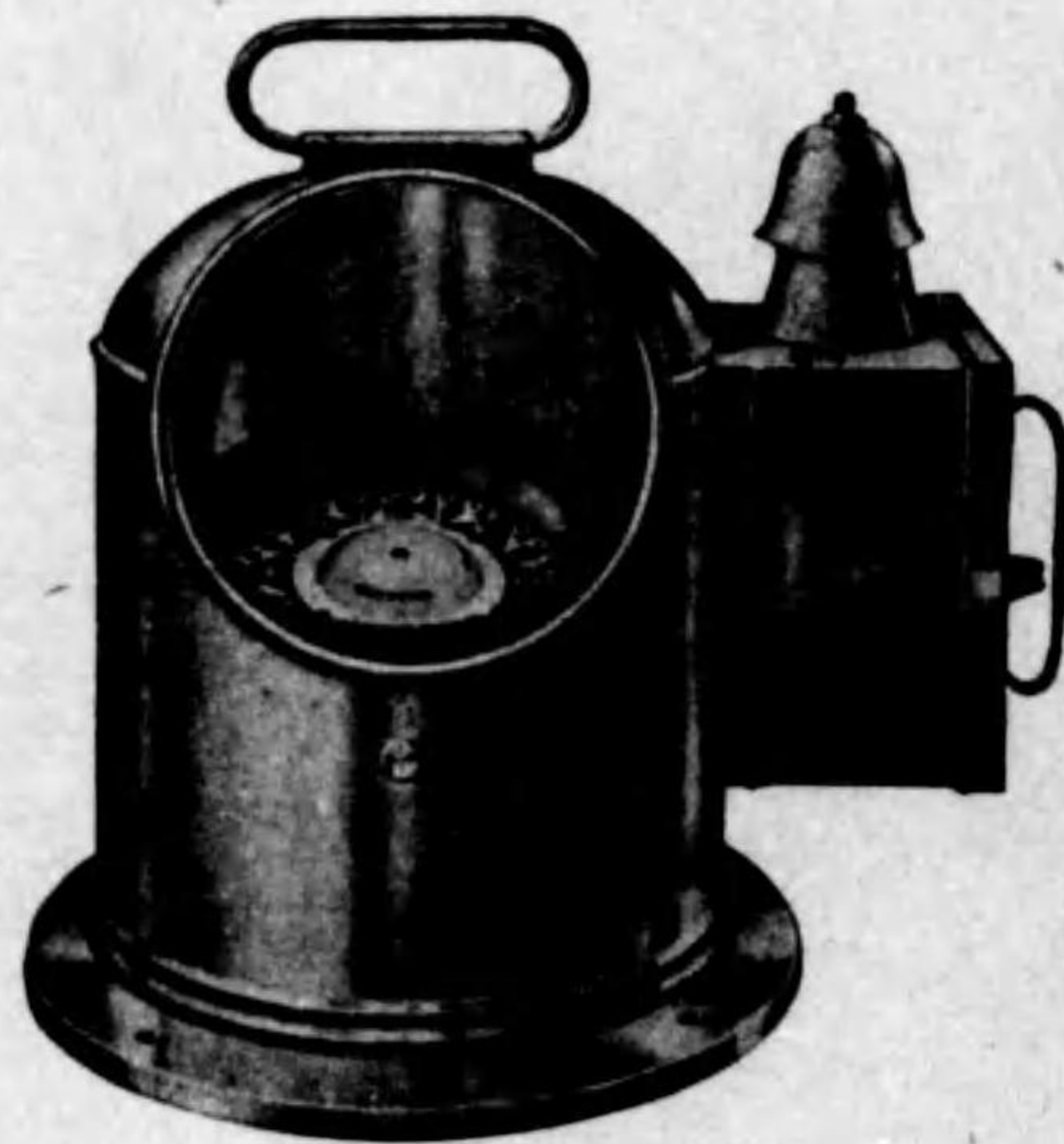

Fig. 10.

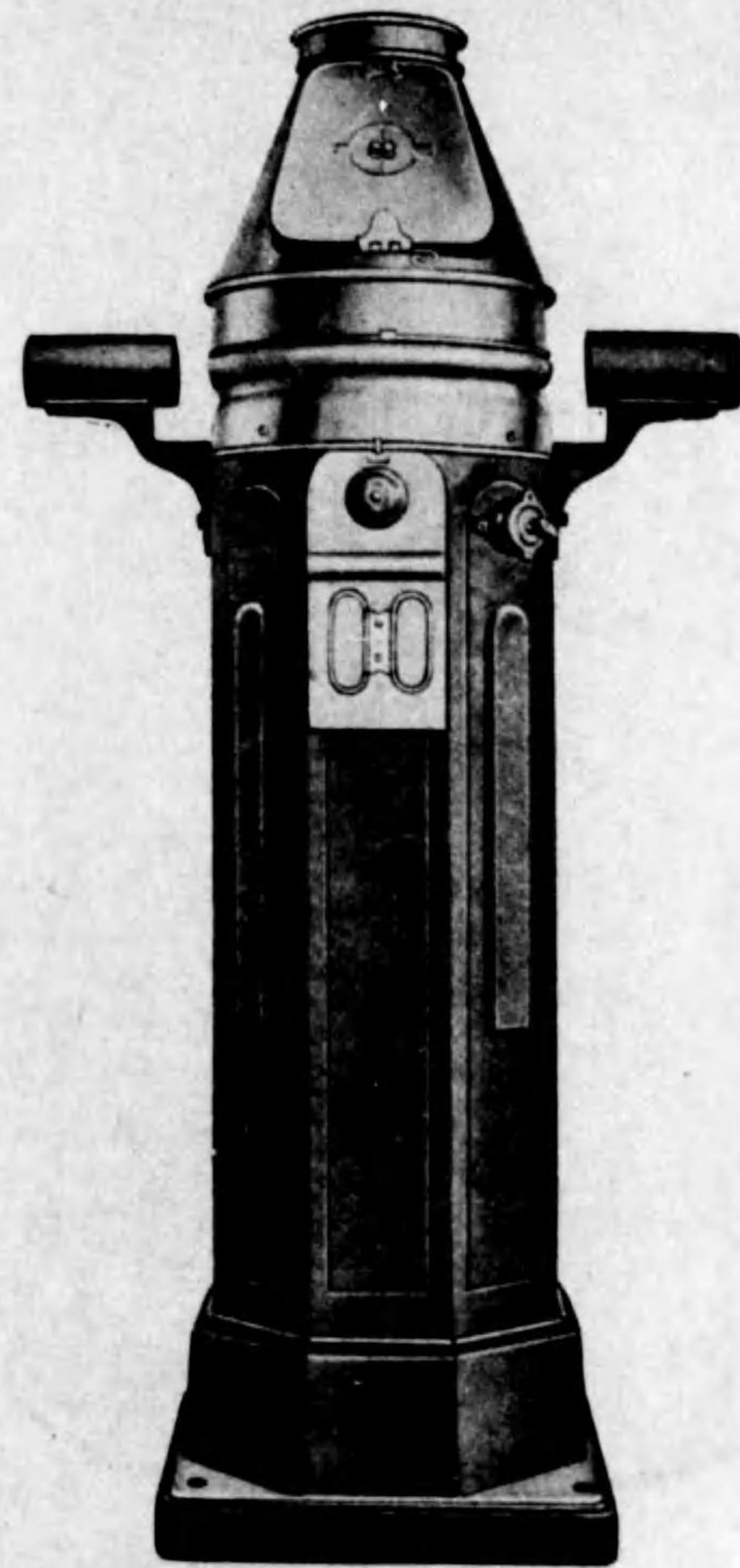

Fig. 11.

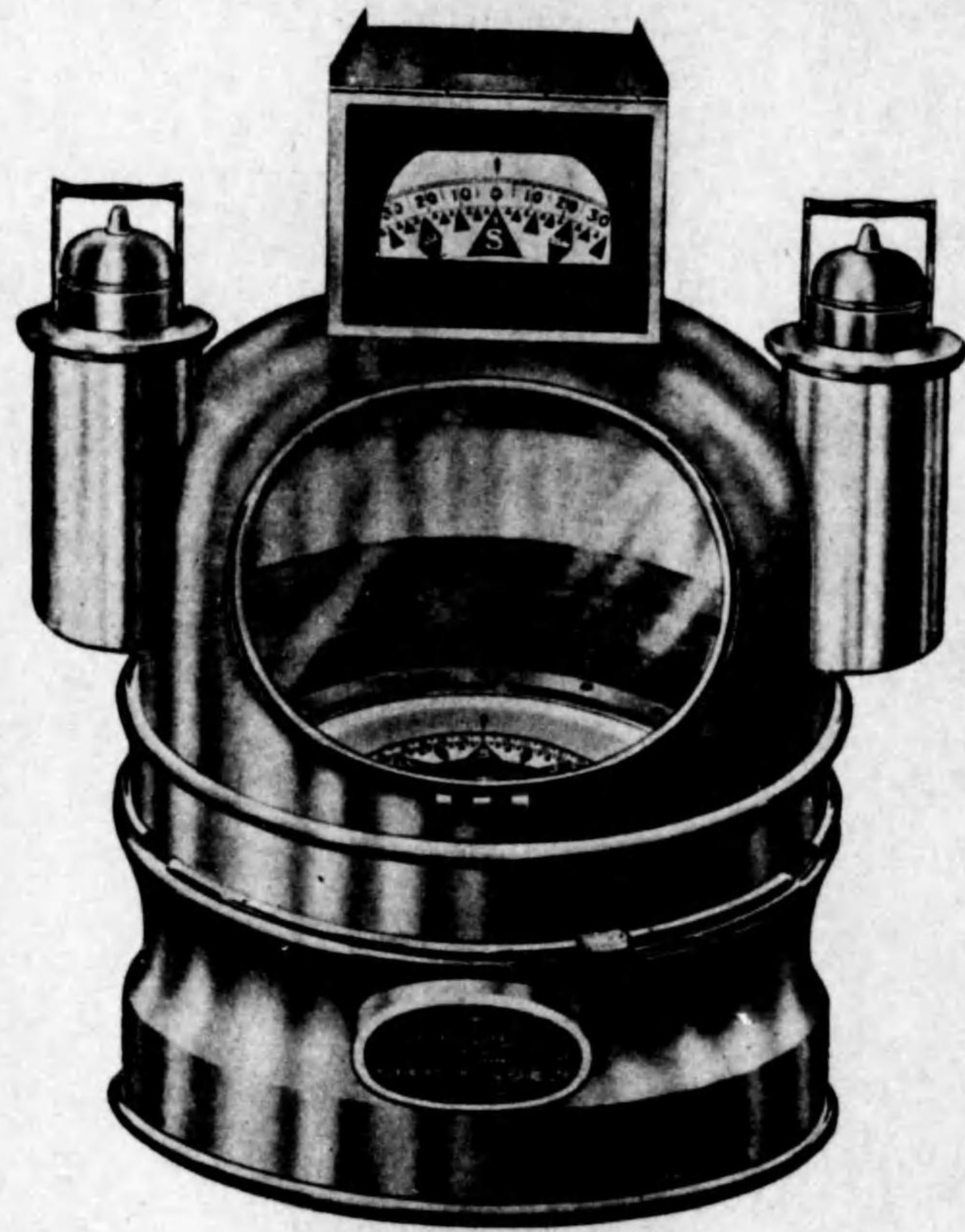

Fig. 12.

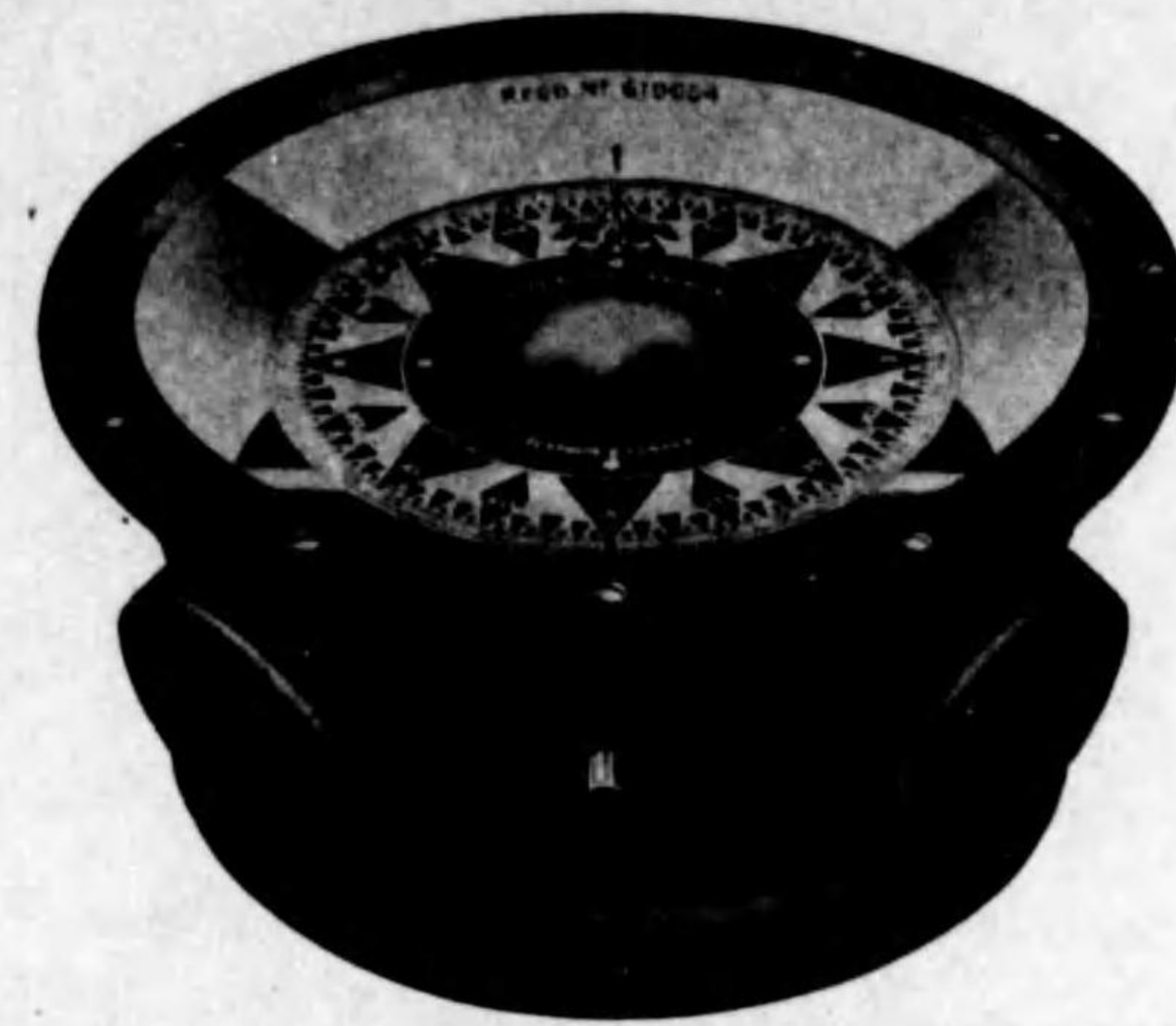

Fig. 13.



Fig. 14. Showing Section of the Bowl of a Liquid Compass.

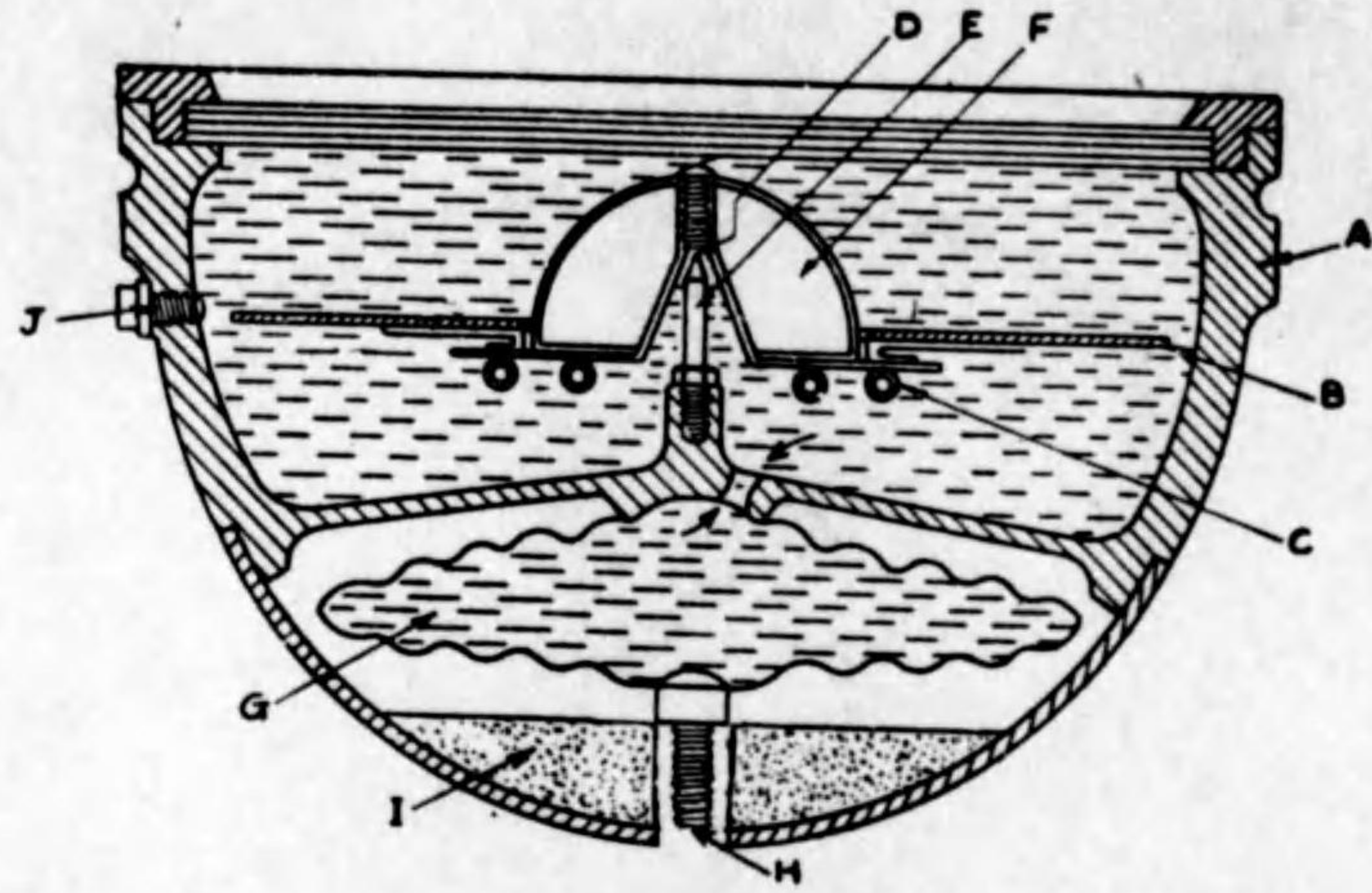

Fig. 15. The bowl of the Chetwynd Compass.

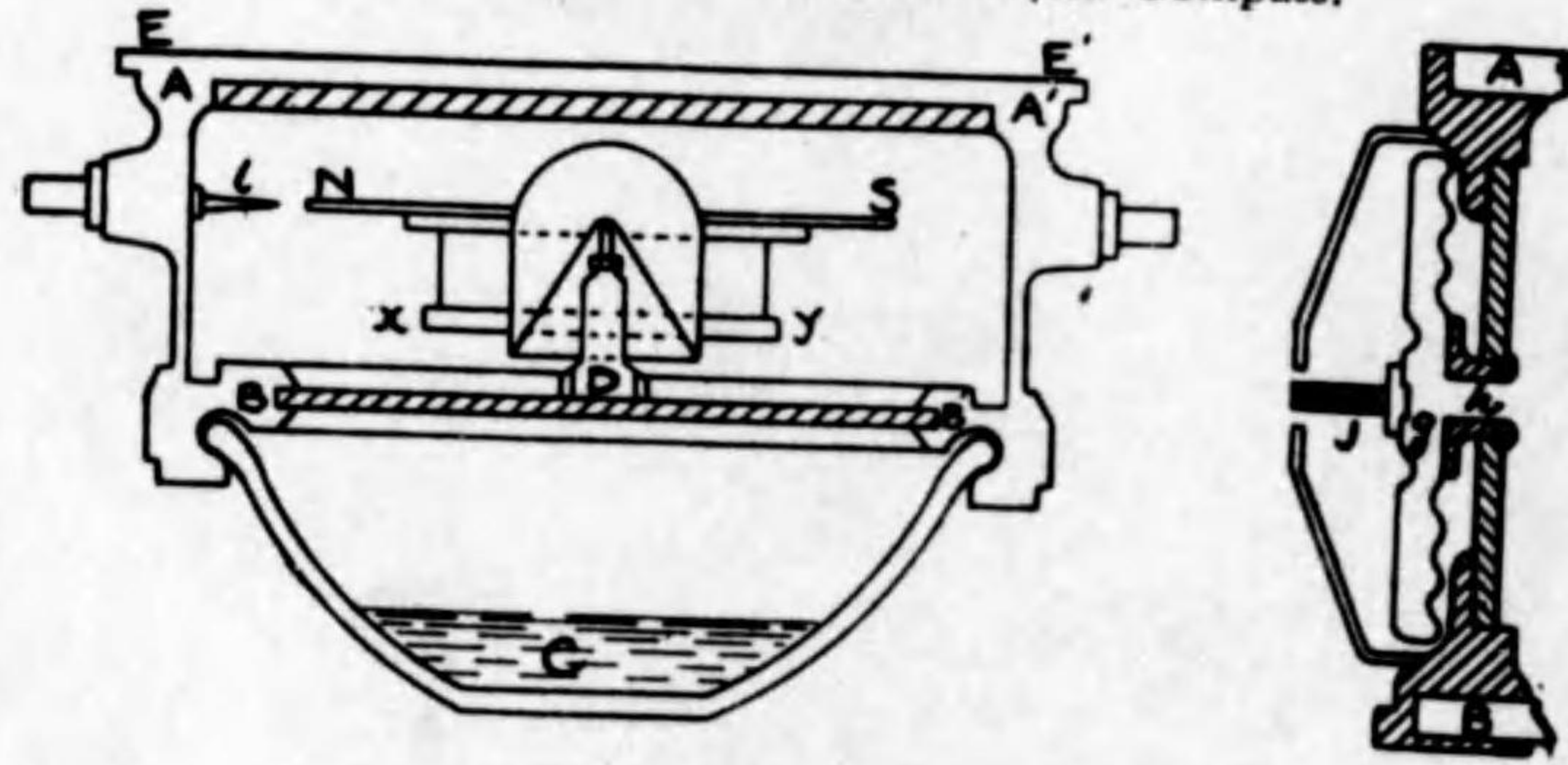

Fig. 16.



Fig. 1.

Azimuth mirror mounted on a Compass bowl.

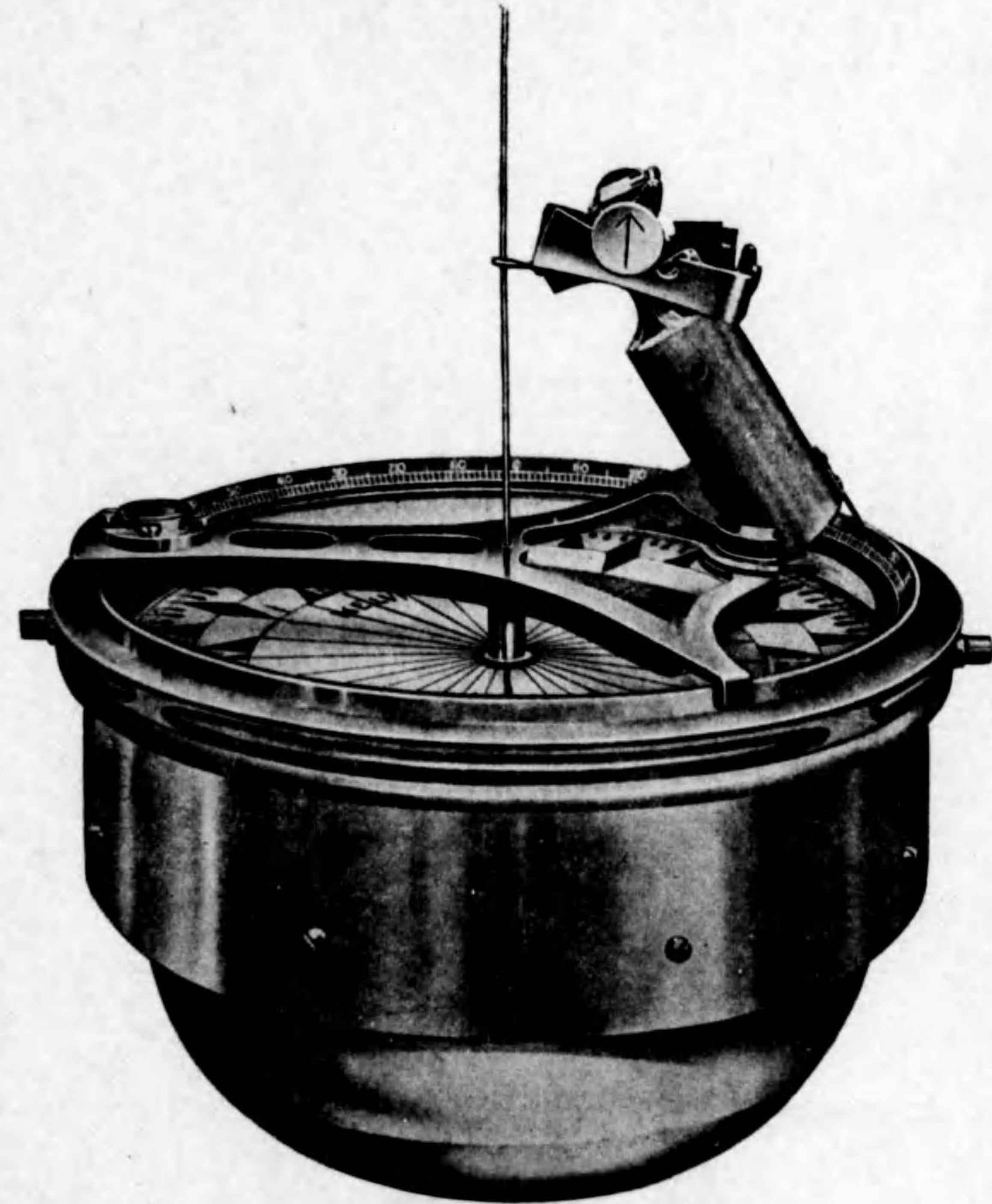

Fig. 2.

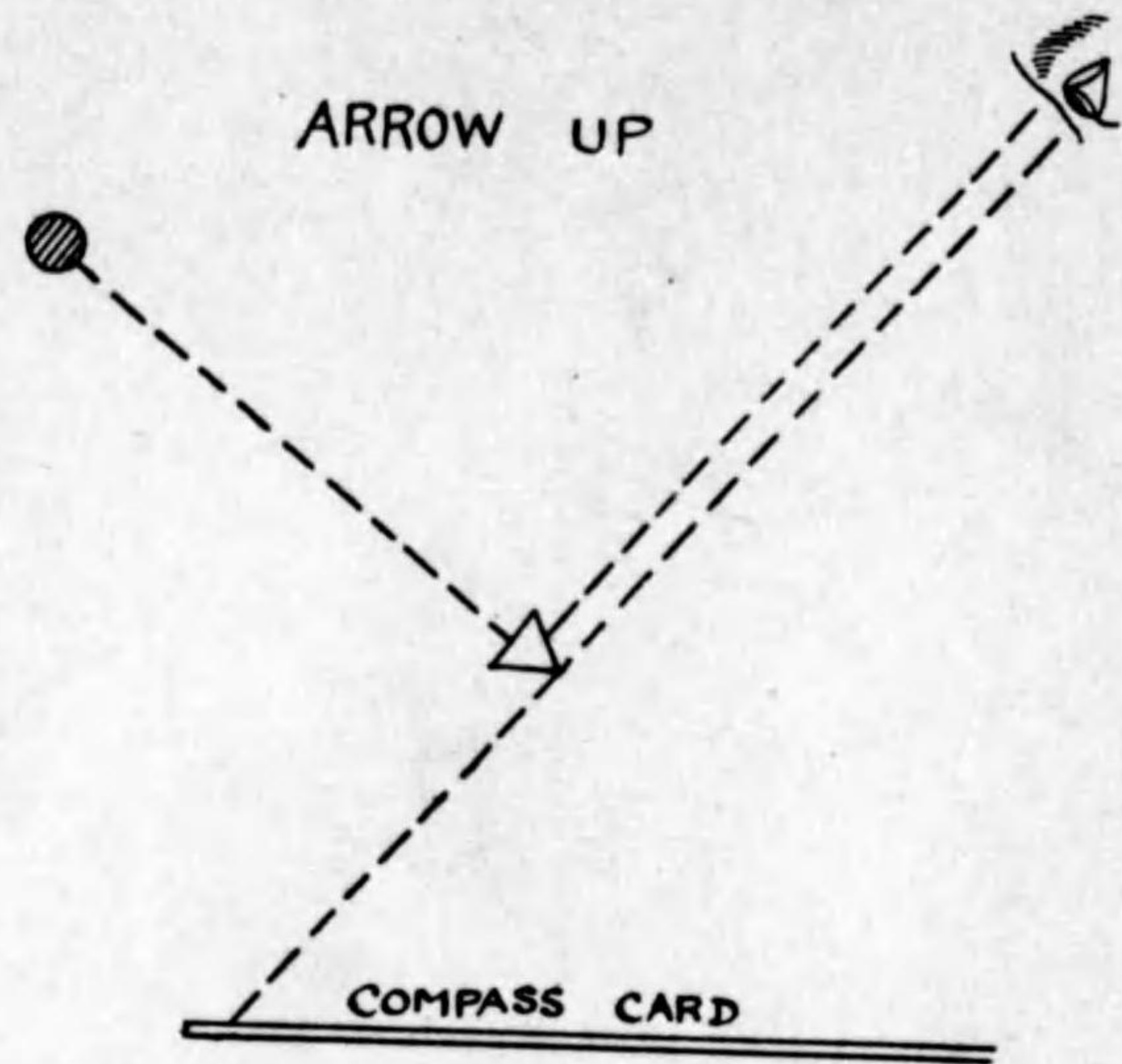

Fig. 3. Arrow down

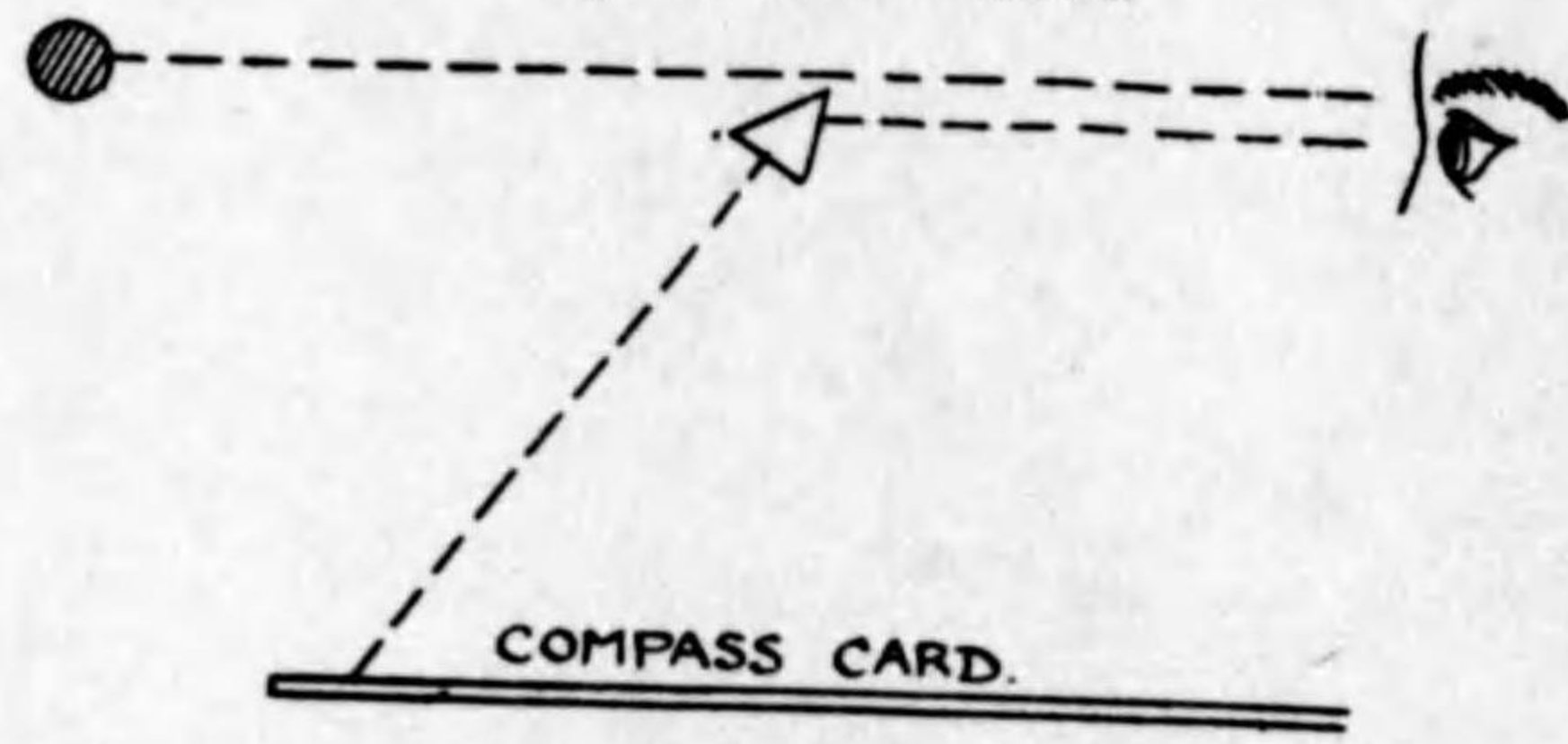

Fig. 4. Azimuth Circle.

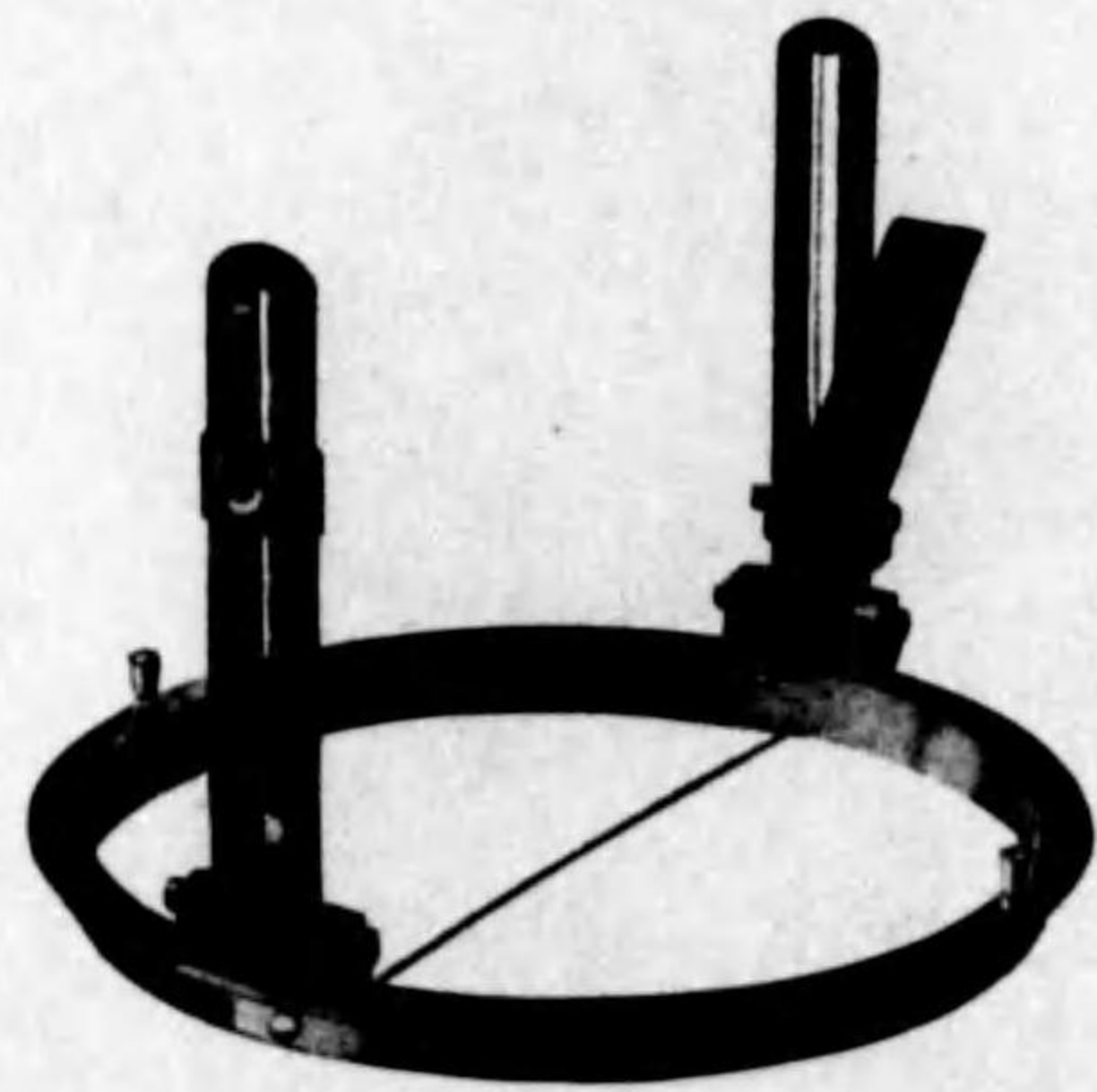

Fig. 1.

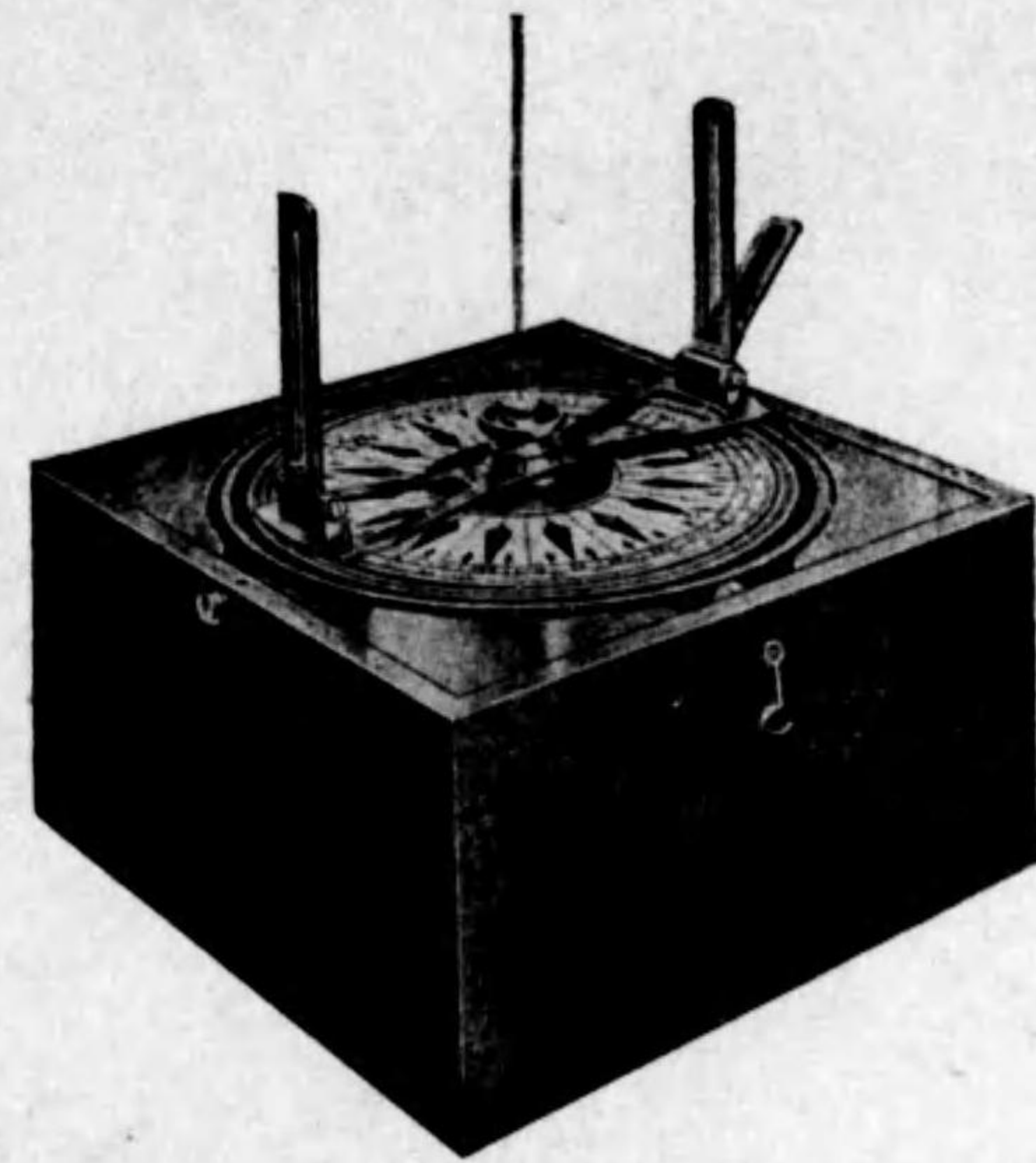

Fig. 2.



Fig. 3.



Fig. 1.
Hand Log. and sand glass.

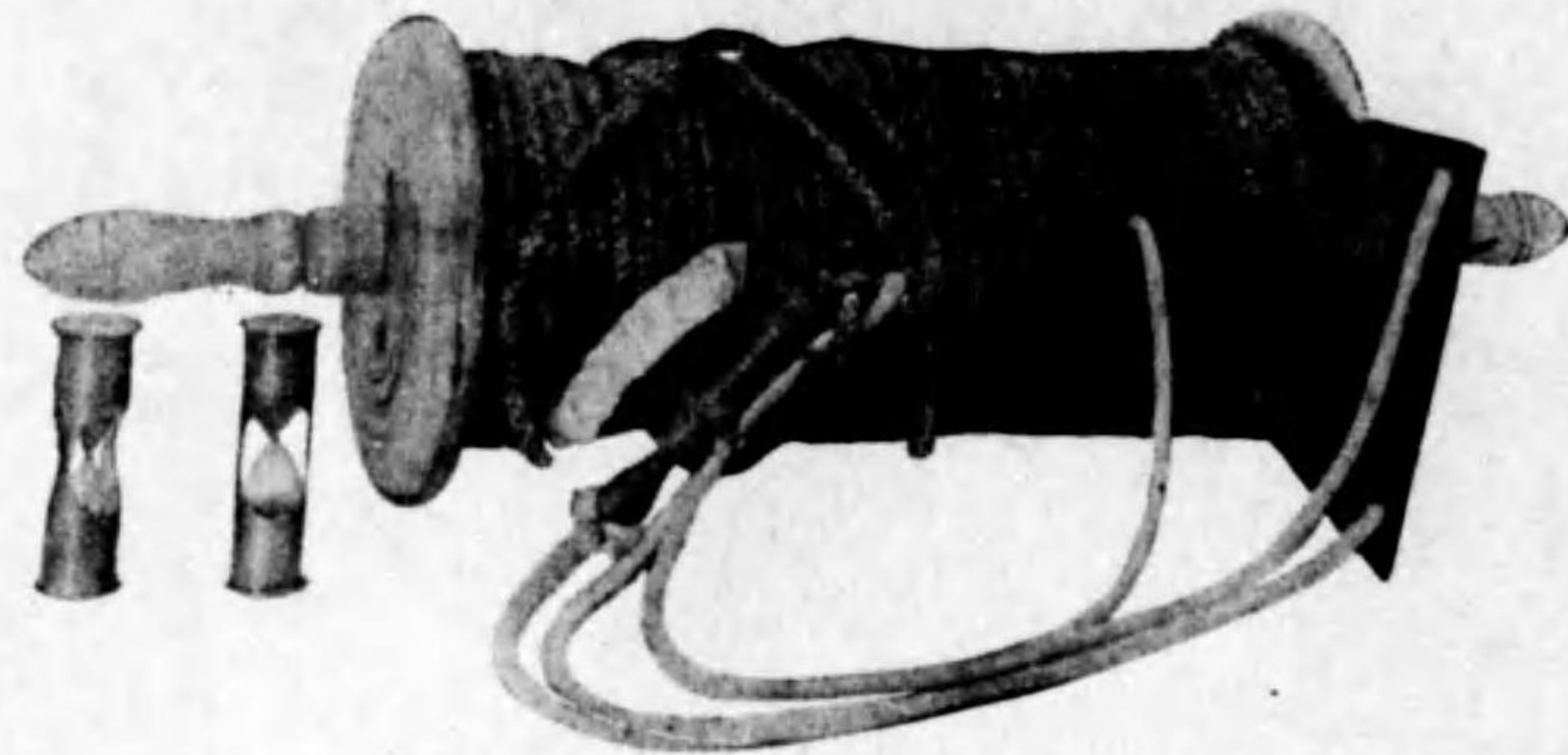

Fig. 2.
Massey's Patent Log.

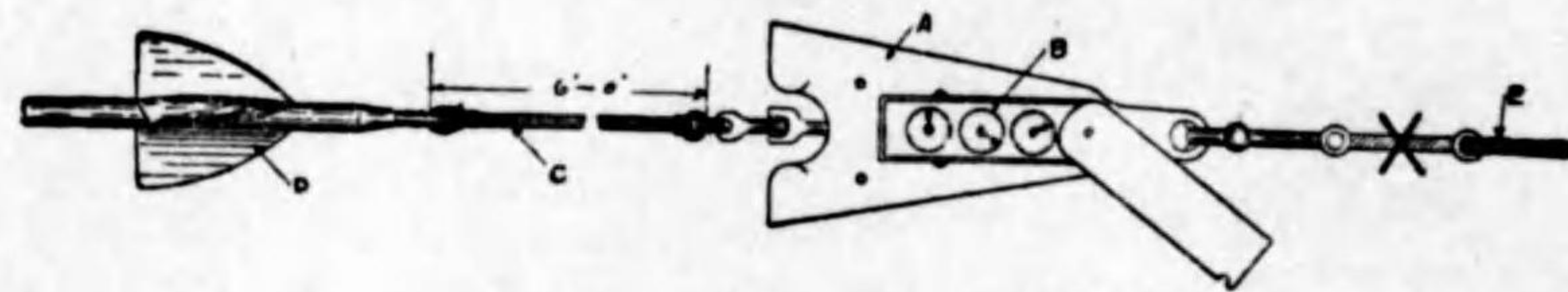

Fig. 3. A.
A. I. Harpoon Log.

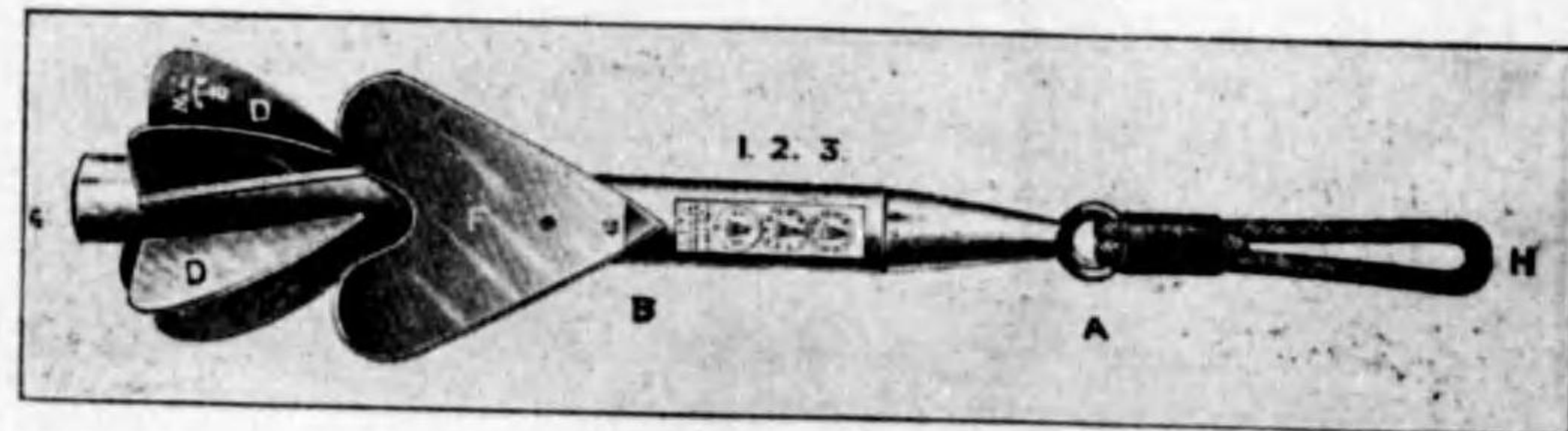

Fig. 3. B.
Harpoon Log.



Fig. 4. A.
Walker's Patent Log. (Register & wheel governor.)

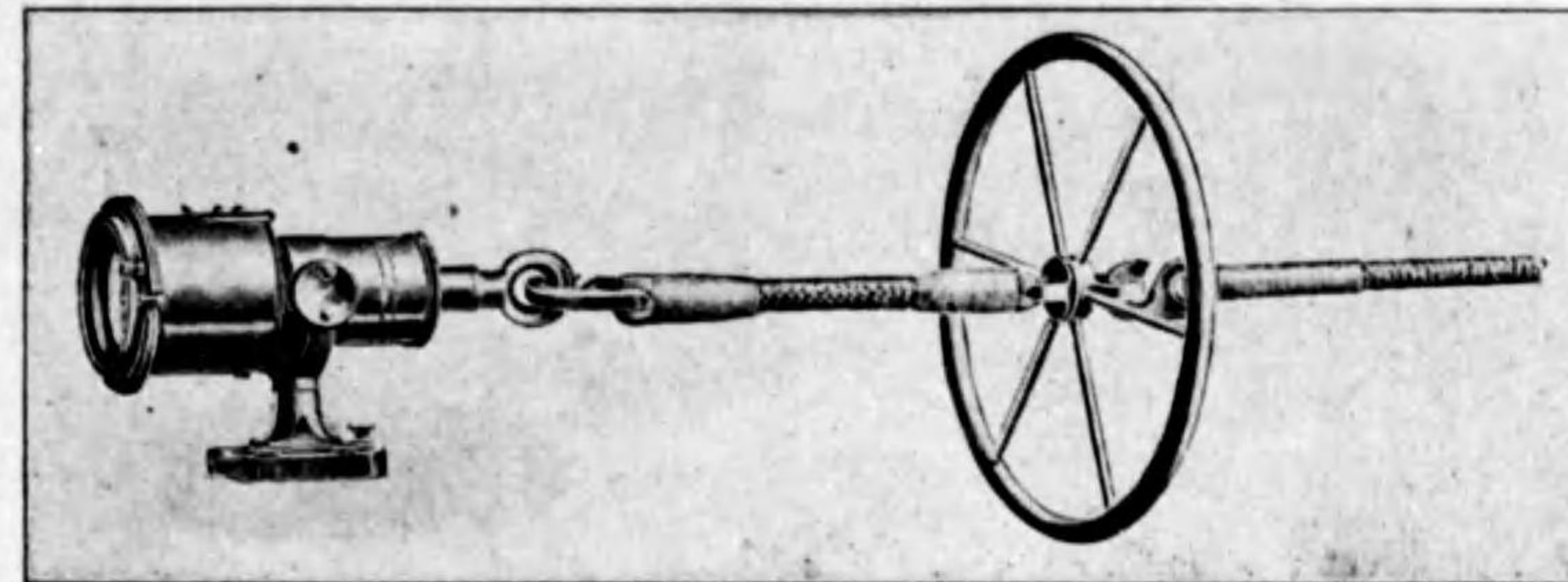

Fig. 4. B.
Rotator.

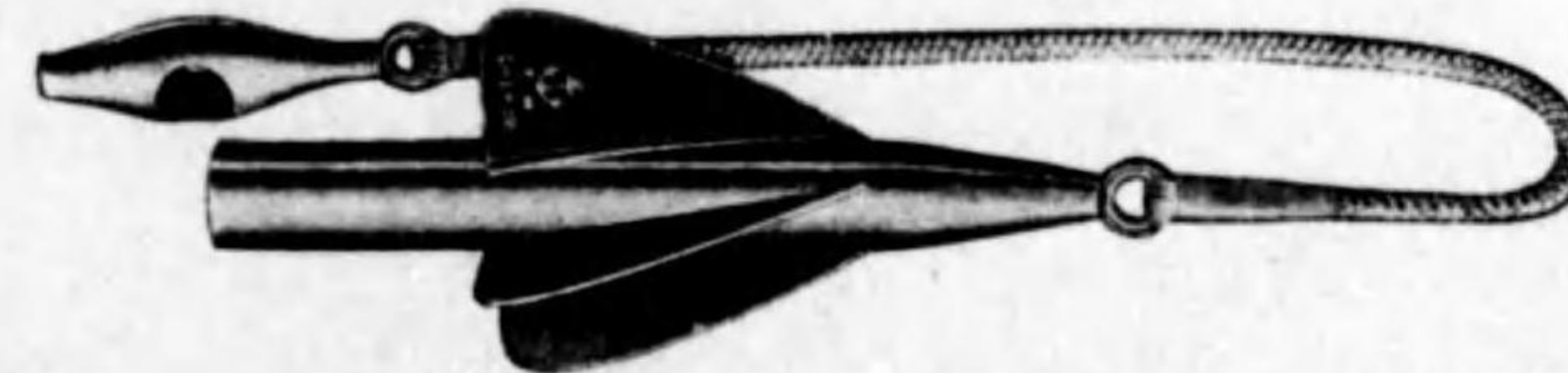

Fig. 5. Cherubal Log. (Register)

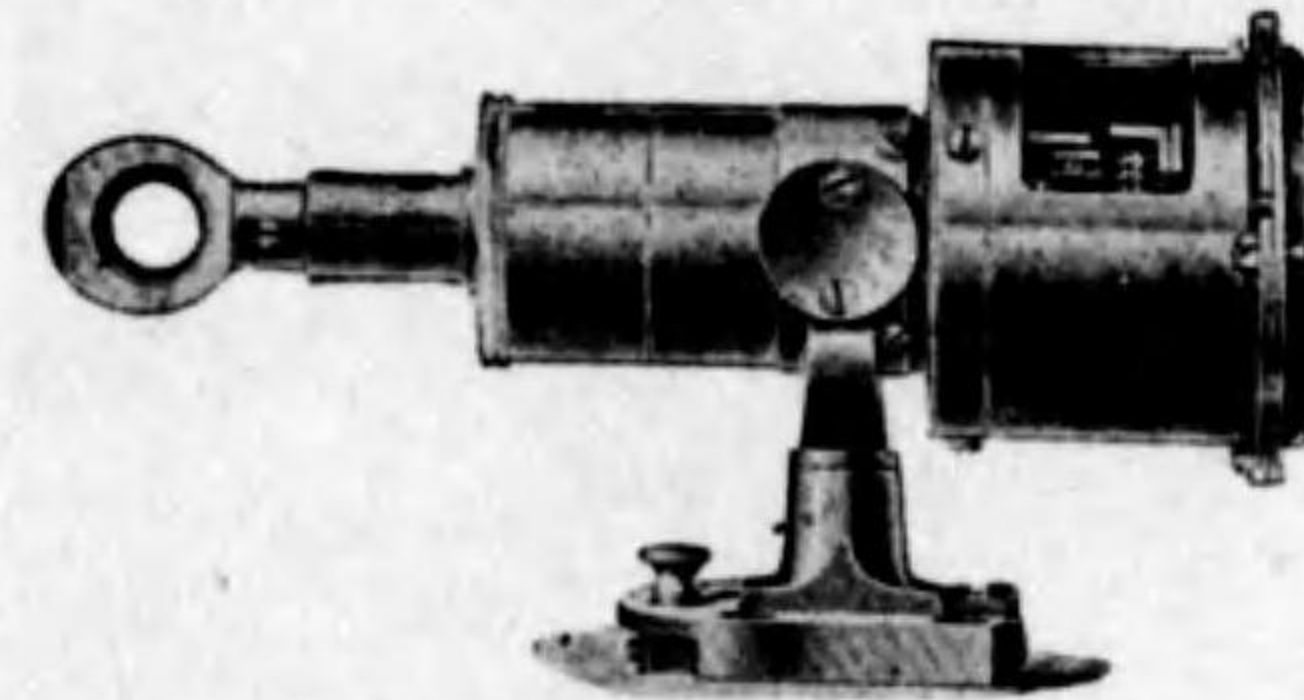

Fig. 6. B.



Fig. 6. A. Neptune Log. (Redister)

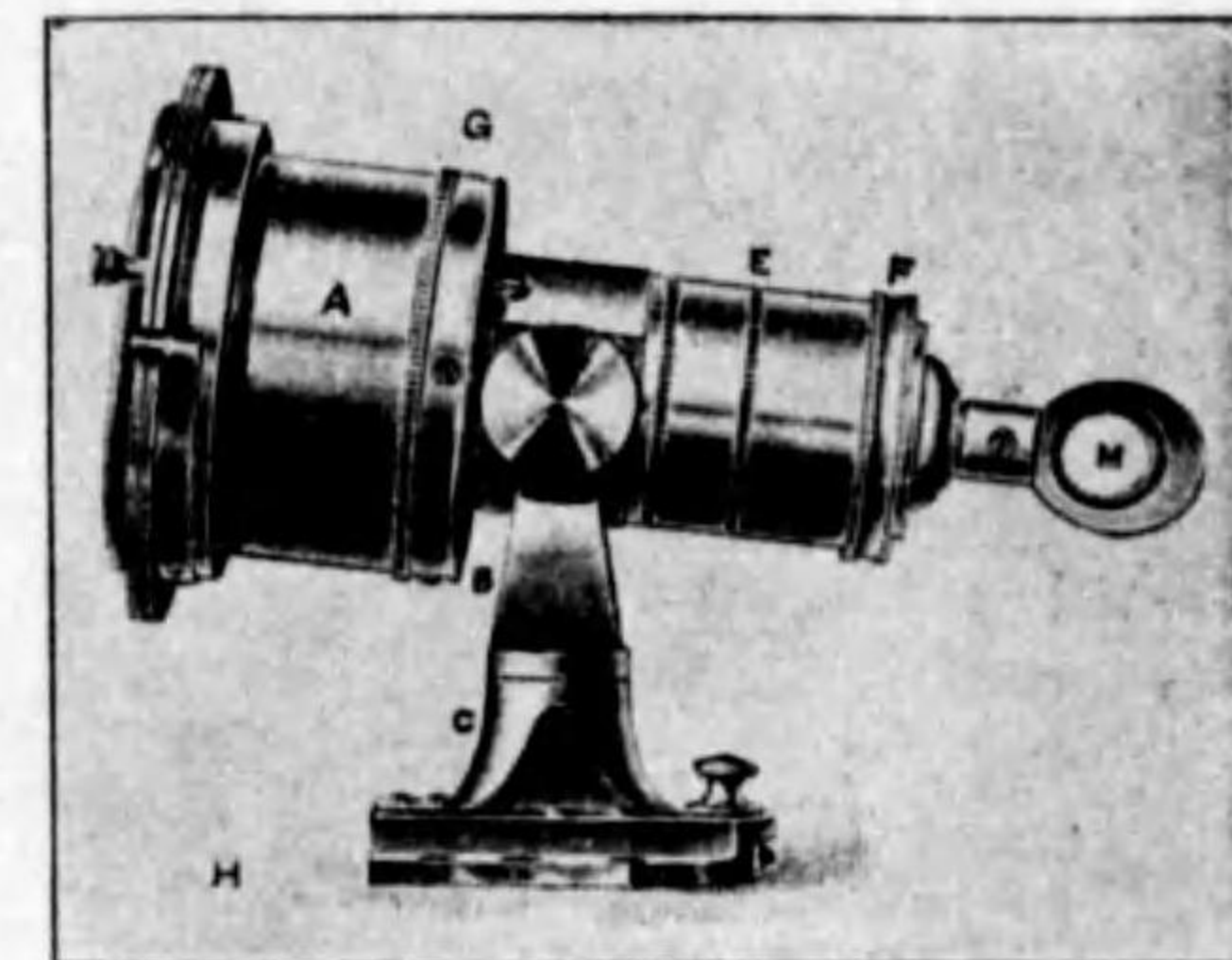

Fig. 6. C.

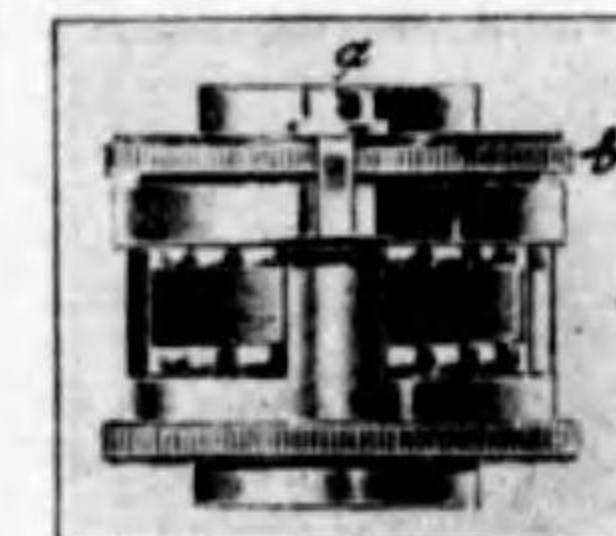

Fig. 2. A.
" Neptune " Electric ship-log.

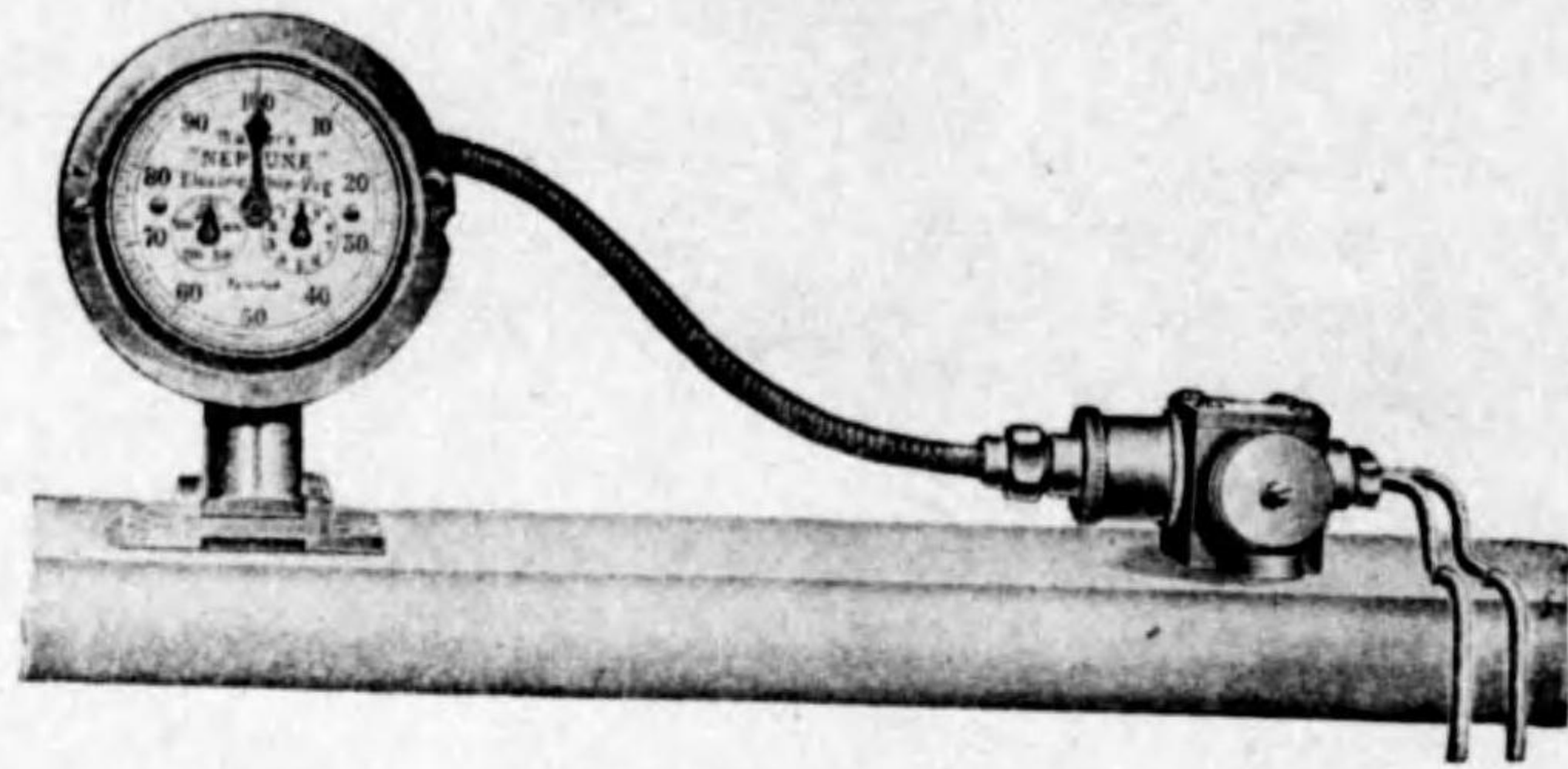

Fig. 7. B.
Electric ship-log. Receiver.

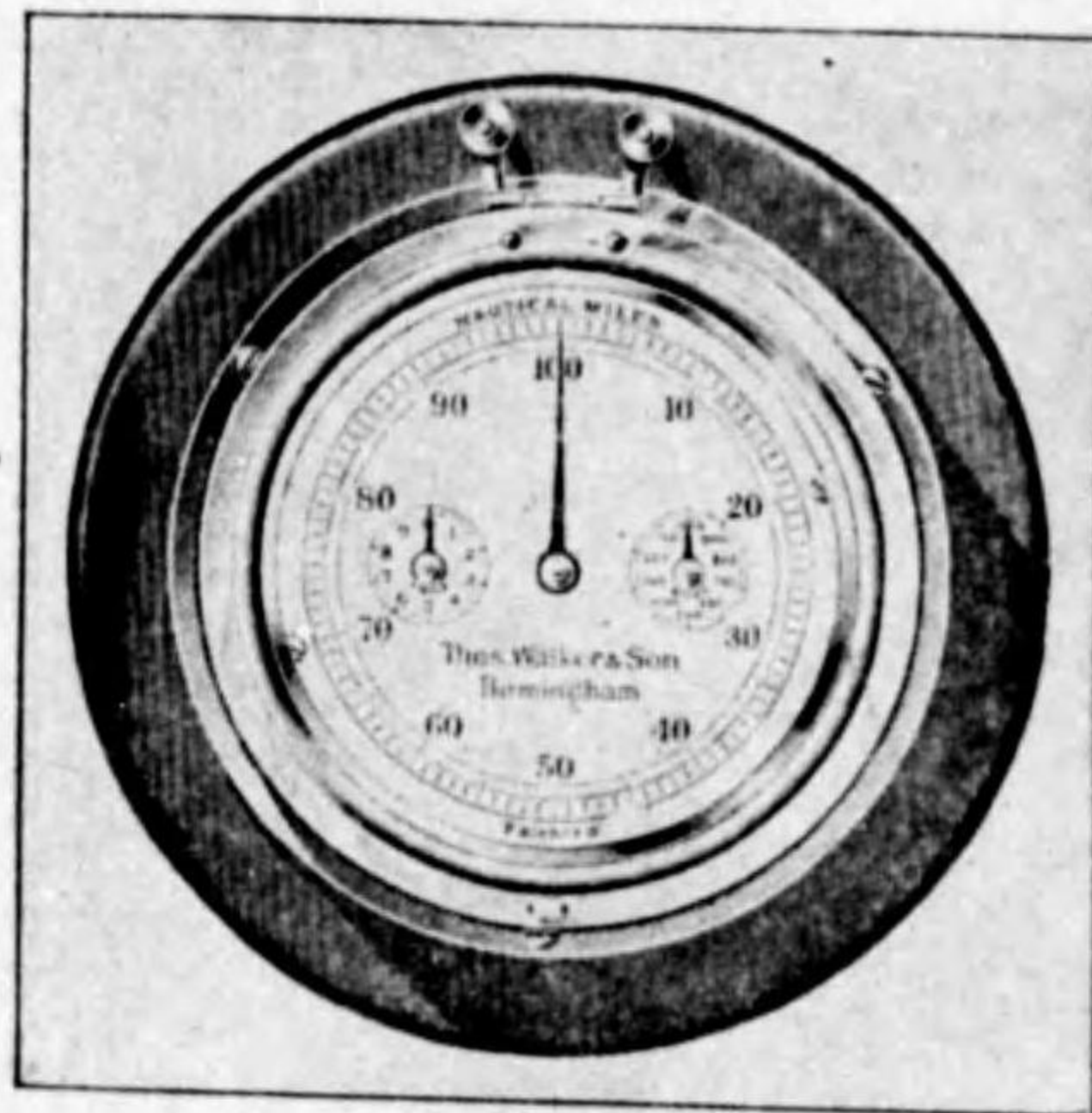

Fig. 8. A.
" Trident " Electric ship-log.

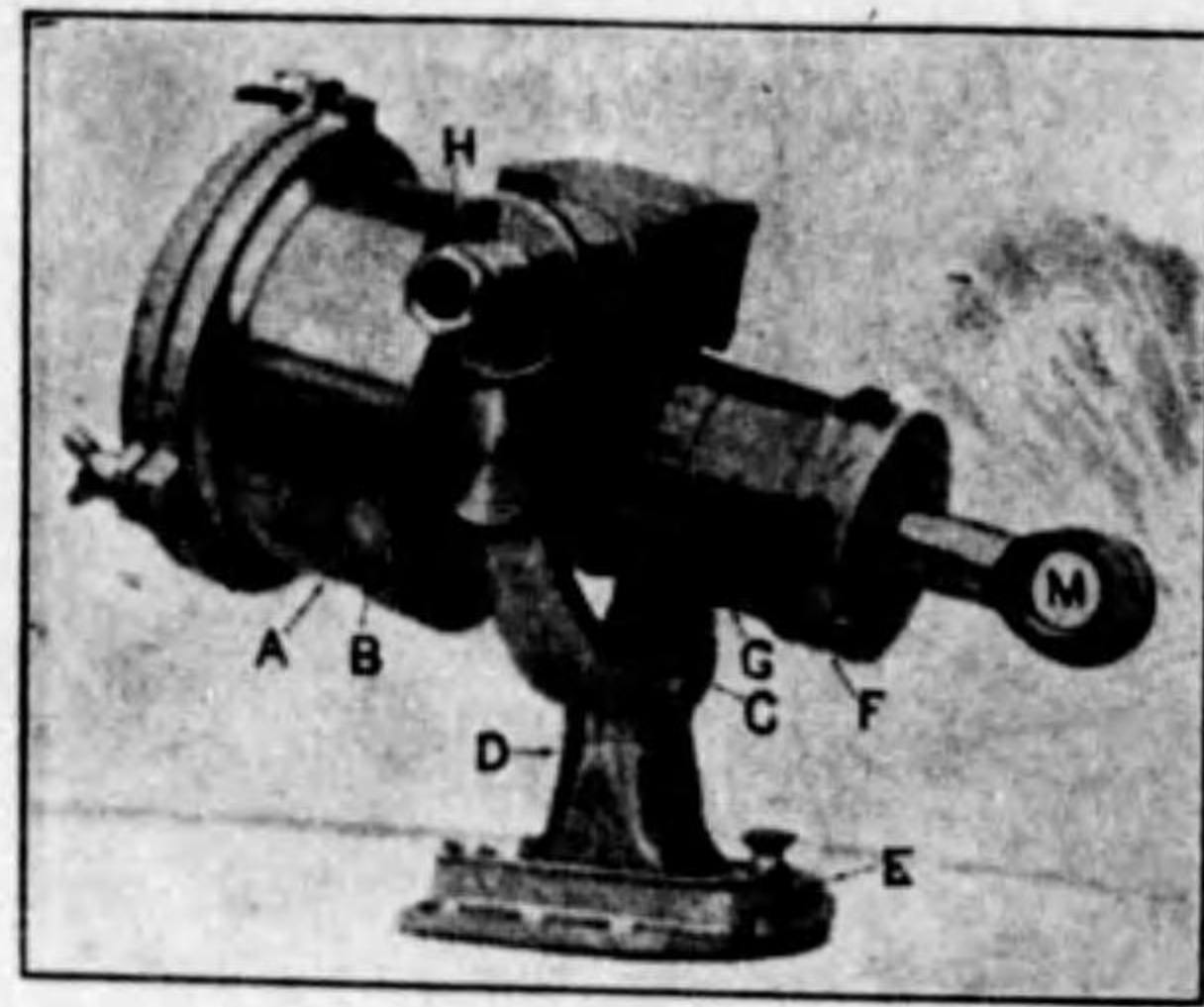

Fig. 8. B.
" Trident " Electric ship-log.

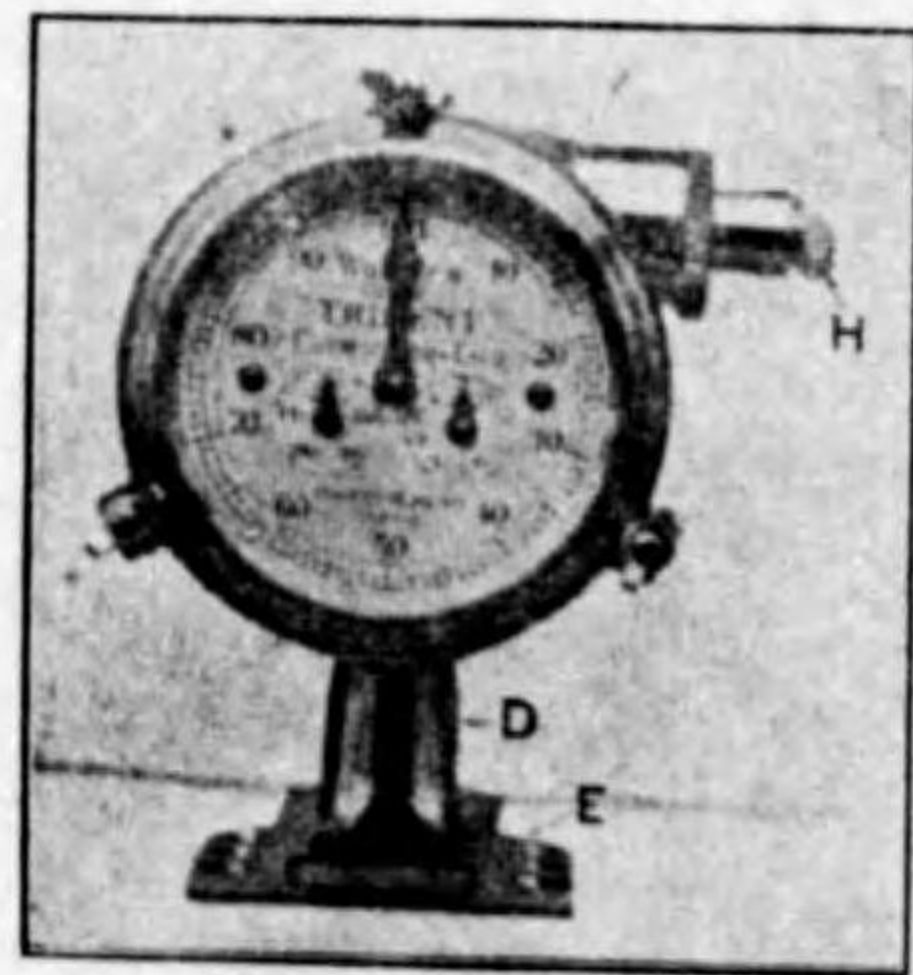

Fig. 9.
Walker's Ship-log. Connector.

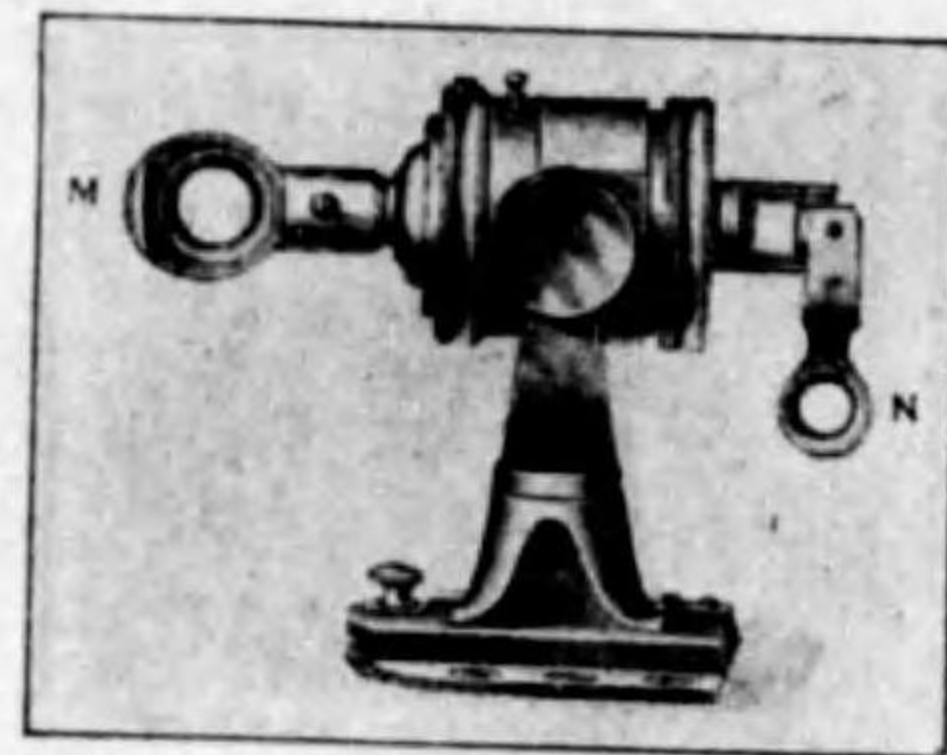

Fig. 10. A.
" Rocket " Ship-log.

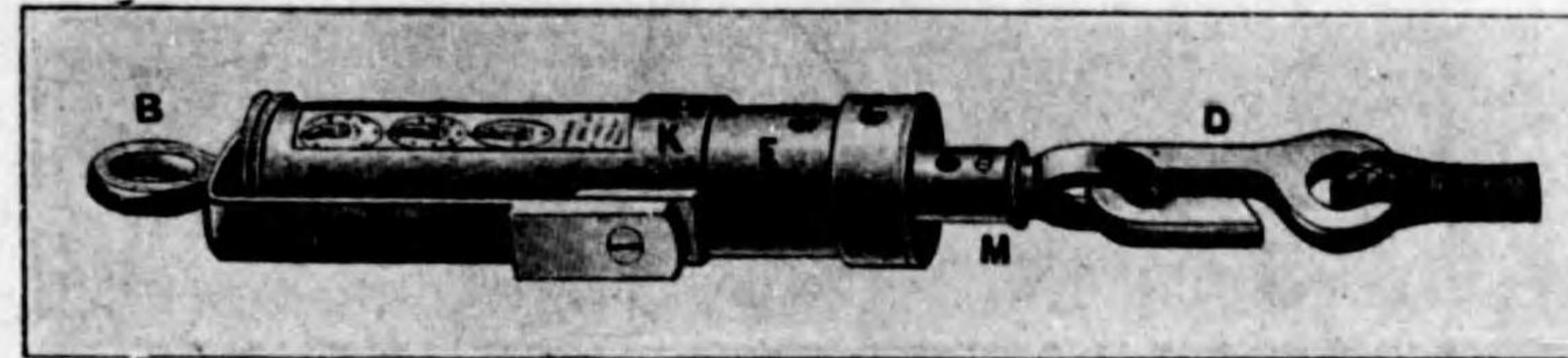

Fig. 10. B.
" Rocket " Ship-log. Rotator.

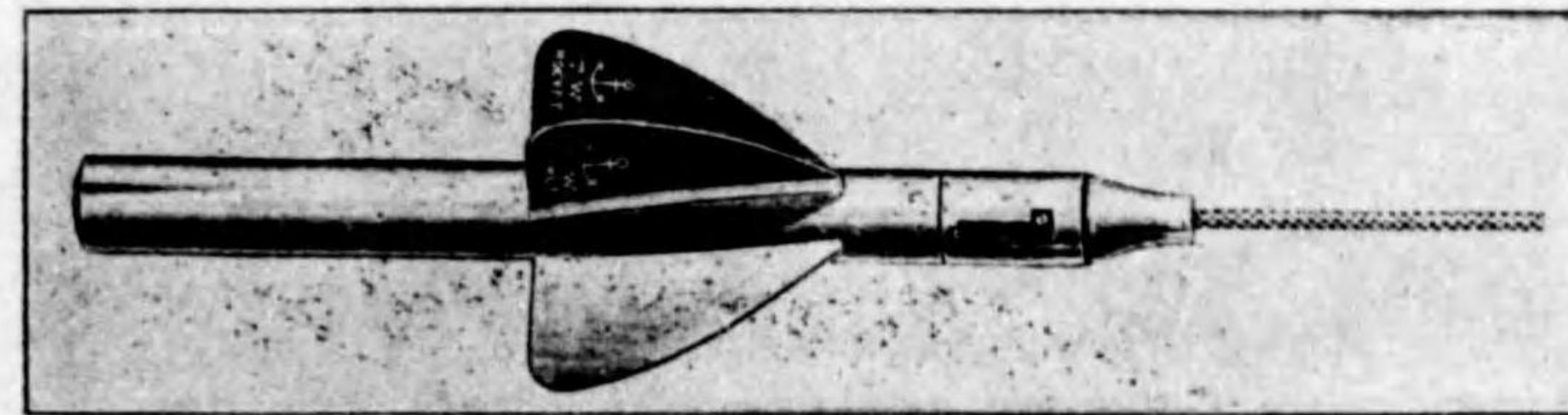

Fig. 11. A.
Walker's " Cherube " and " Cherubal " Ship-log. Parts.

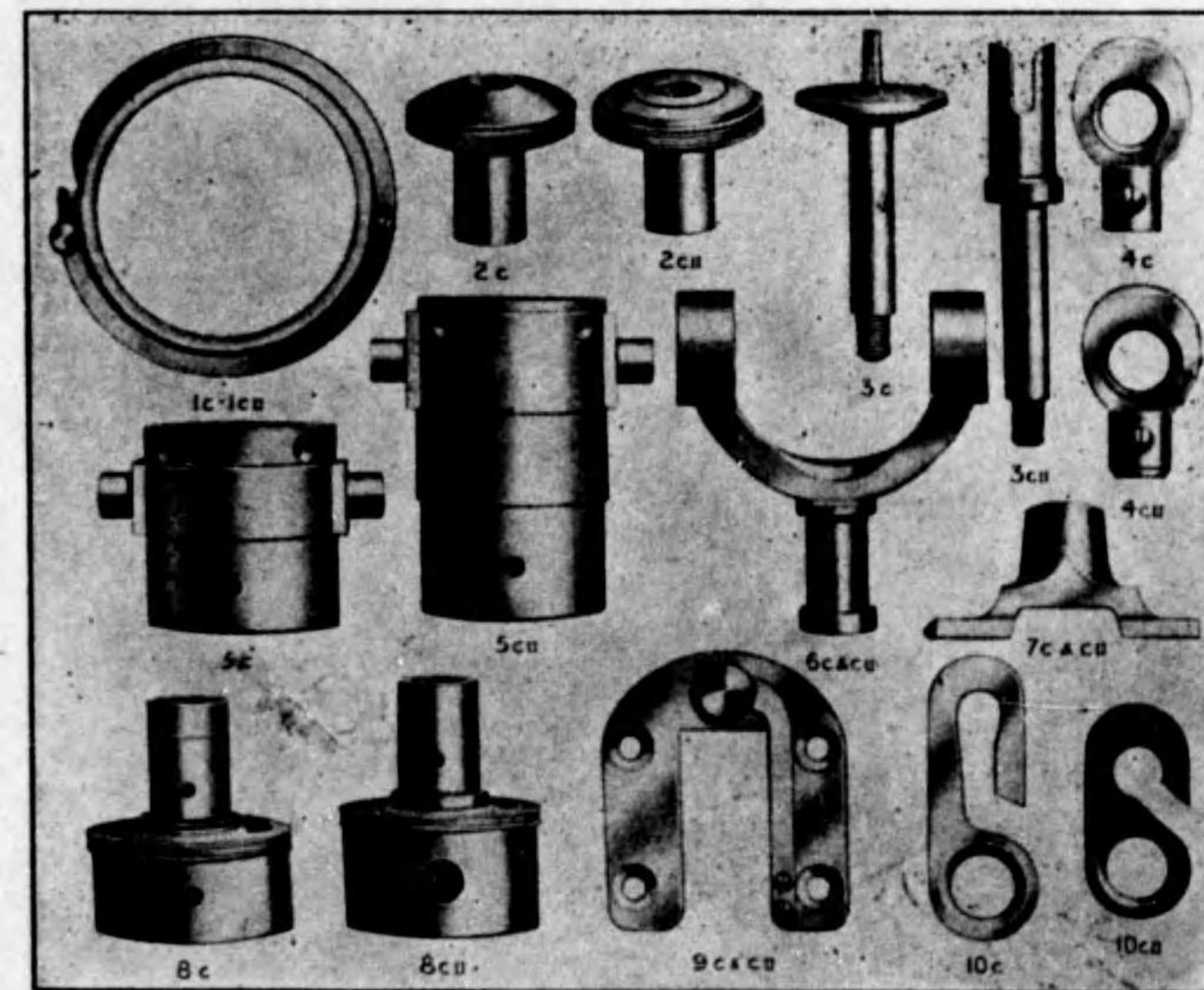

Fig. 11. B.

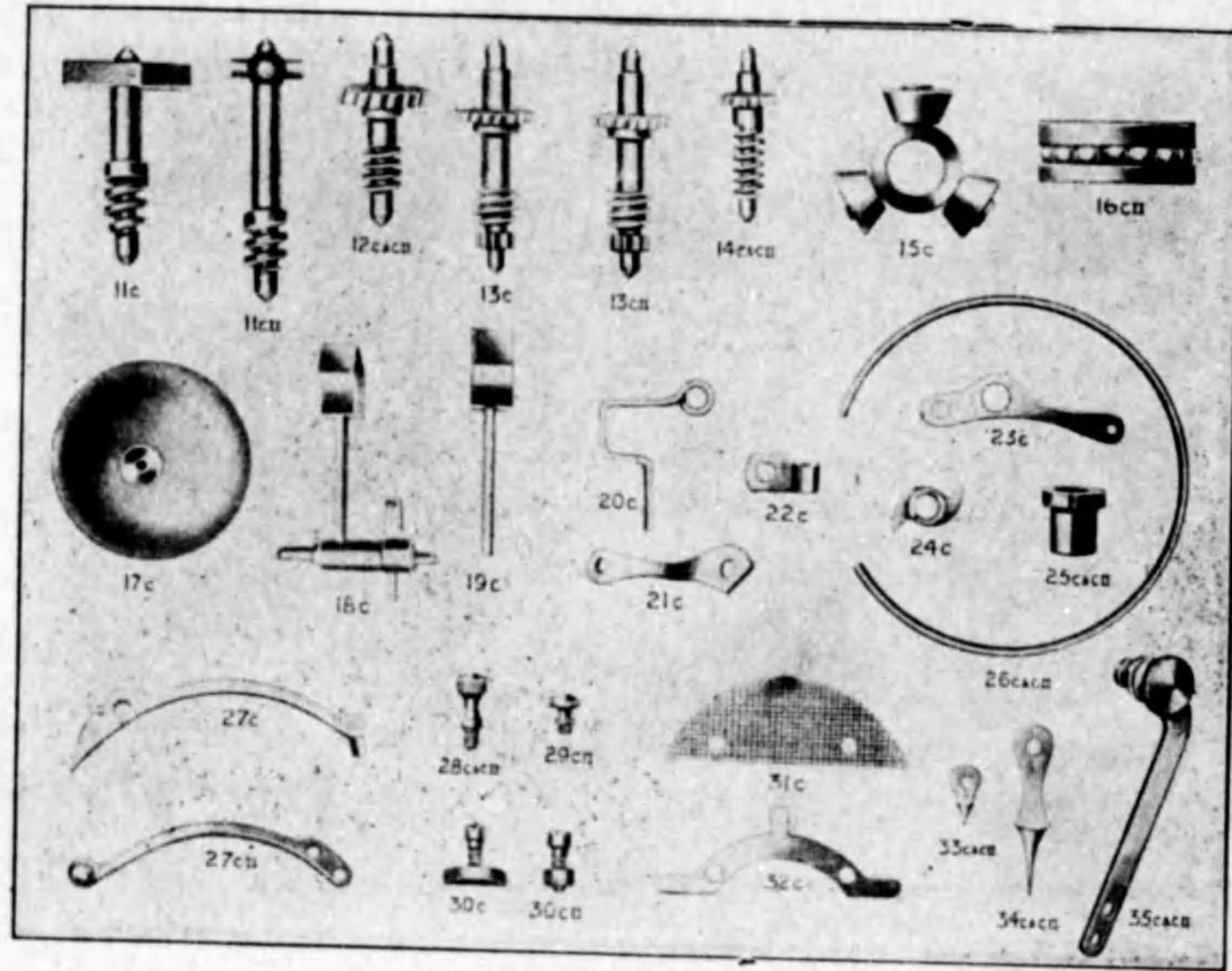

Fig. 12. A.

Walker's "Neptune" and "Trident" Ship-log. Parts.

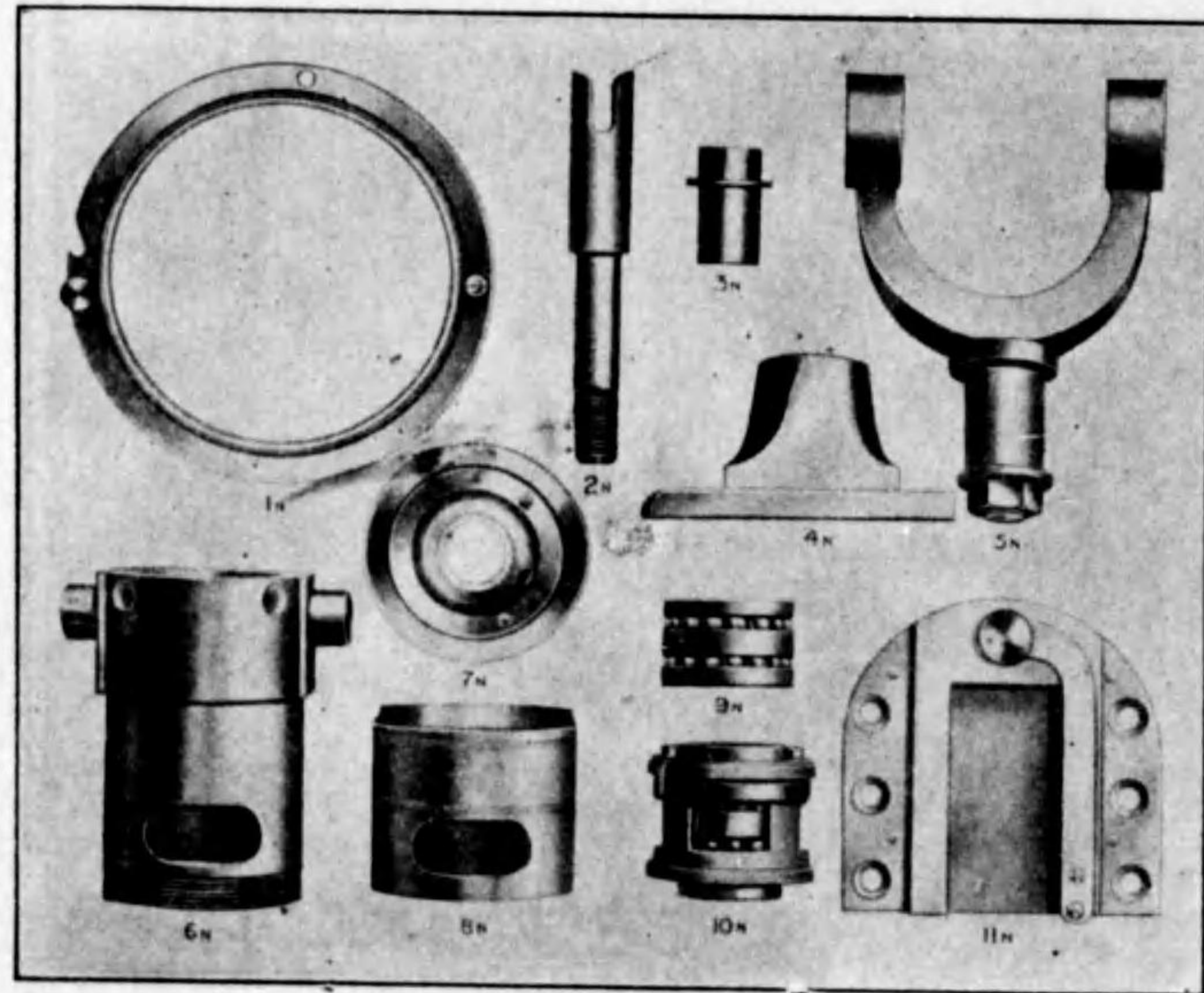

Fig. 12. B.

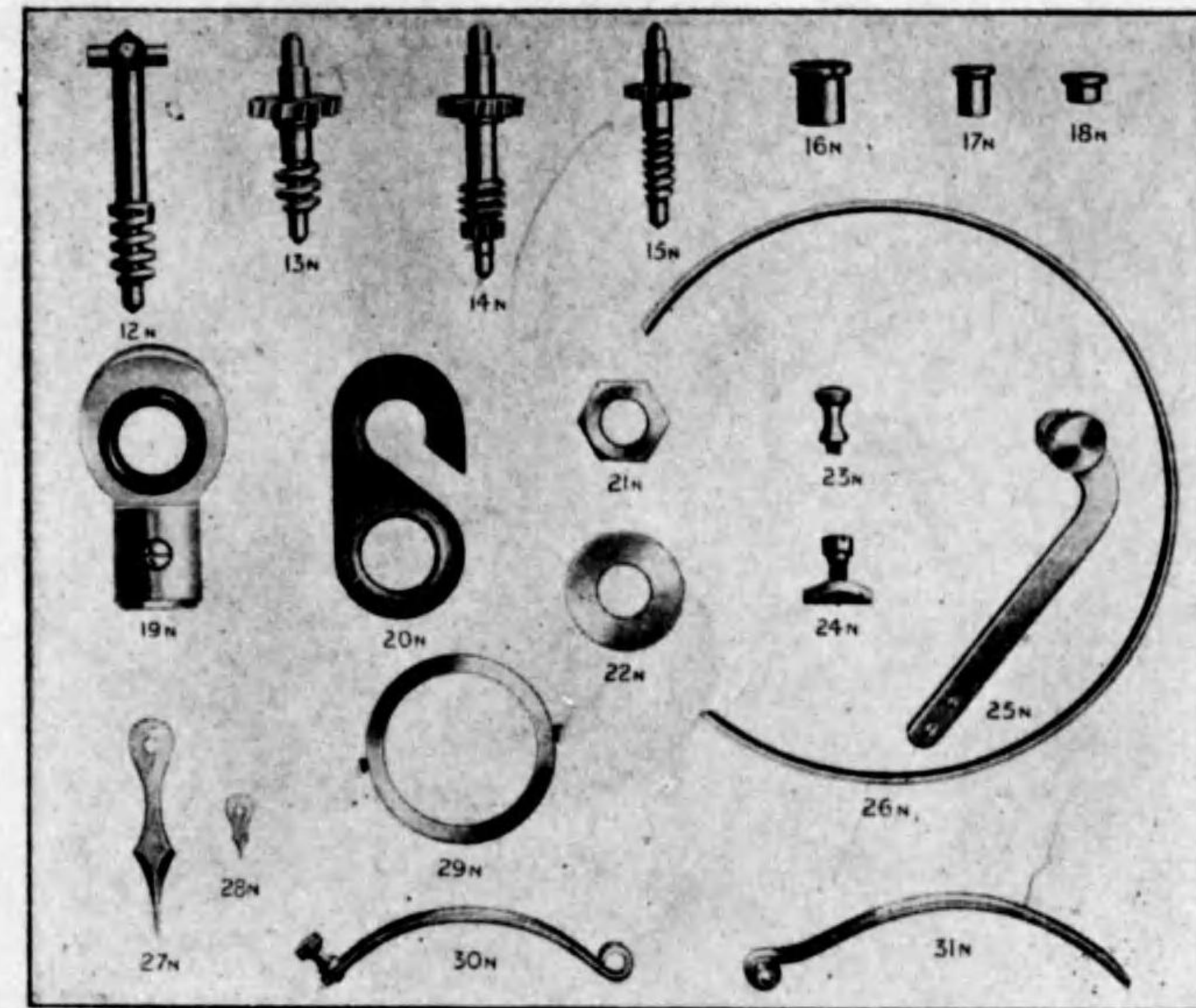

Fig. 2. A. Lord Kelvin's sounding machine.



Fig. 1.
Hand lead.



Fig. 2. B.

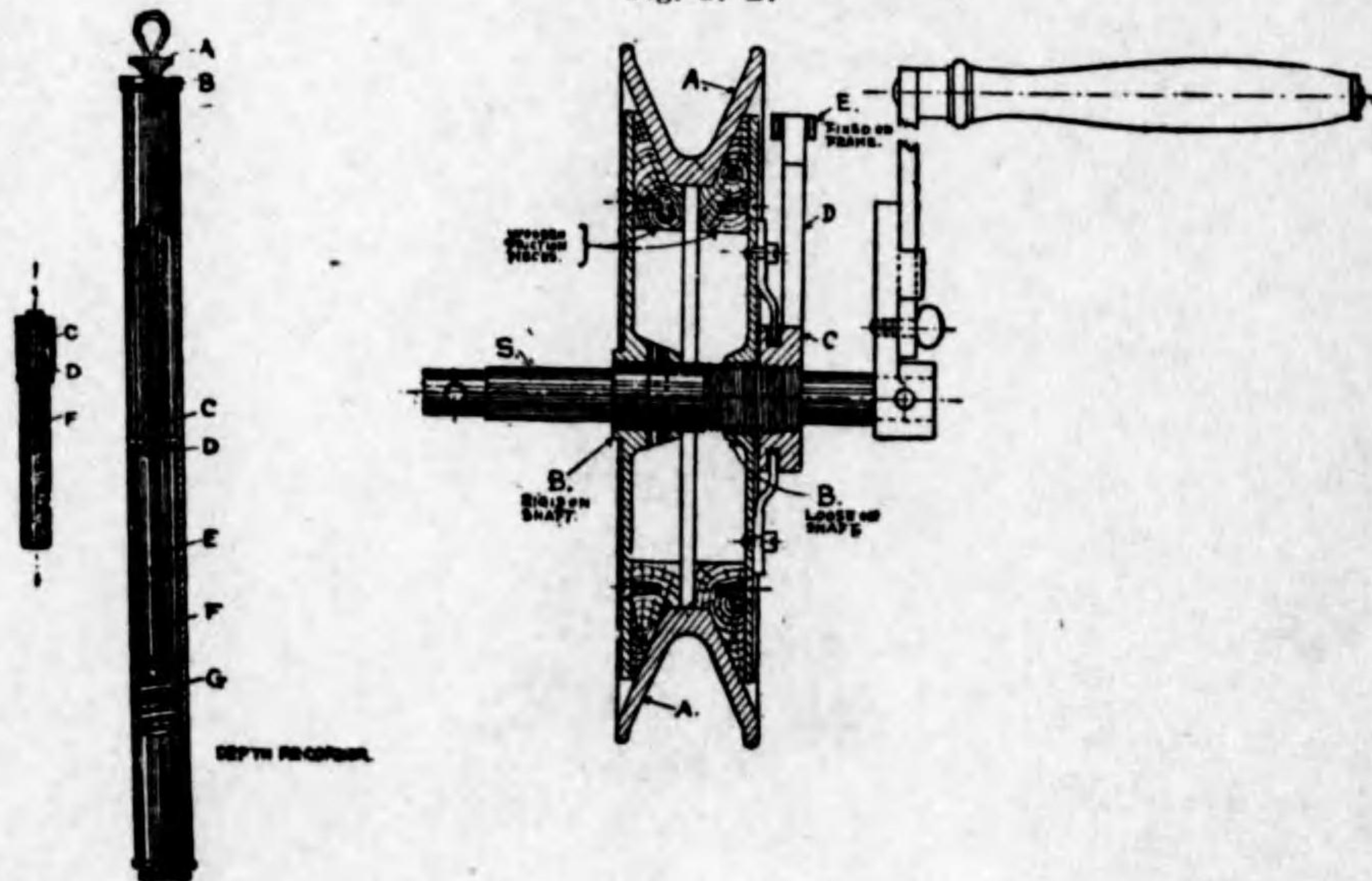

Fig. 3.

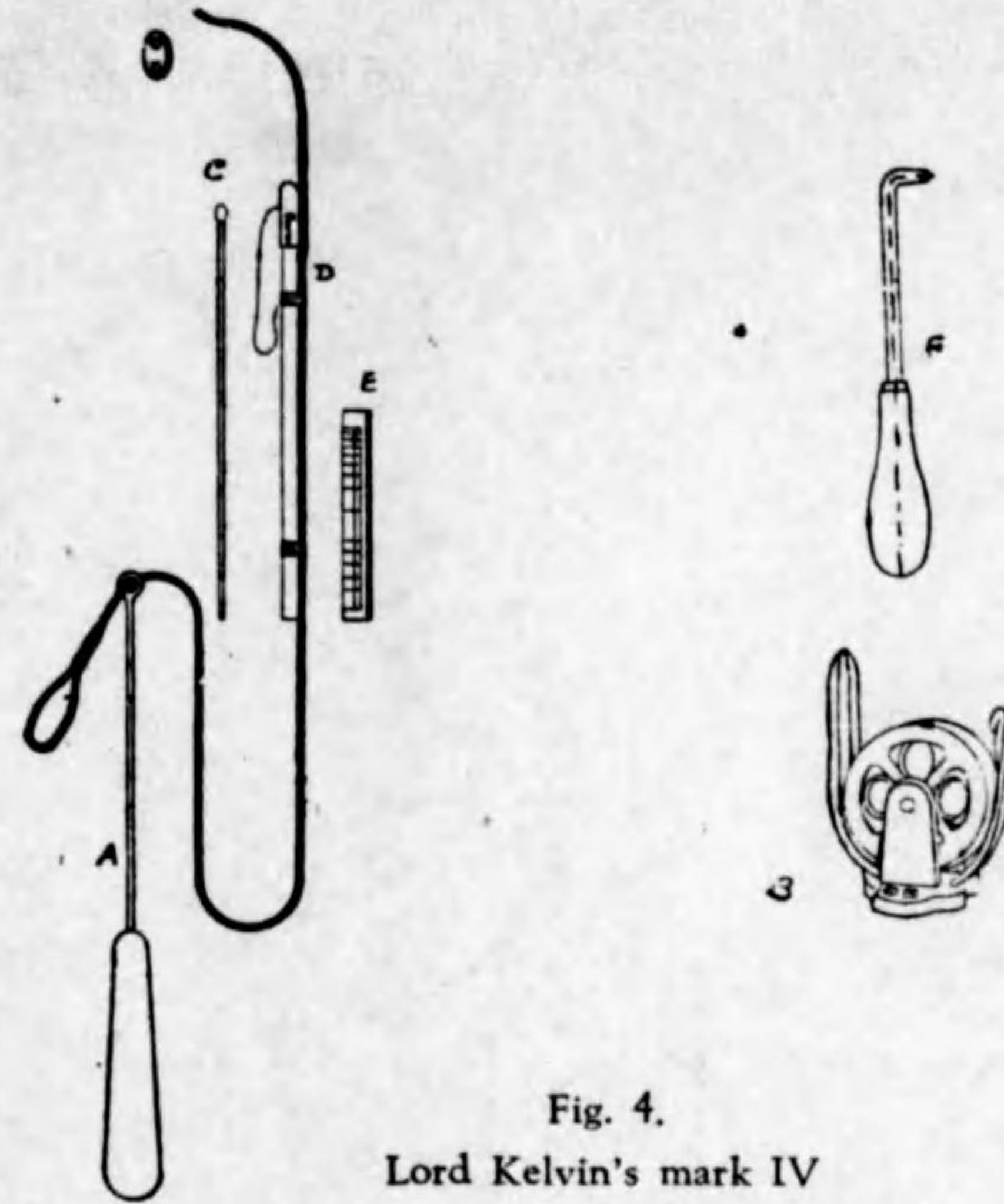
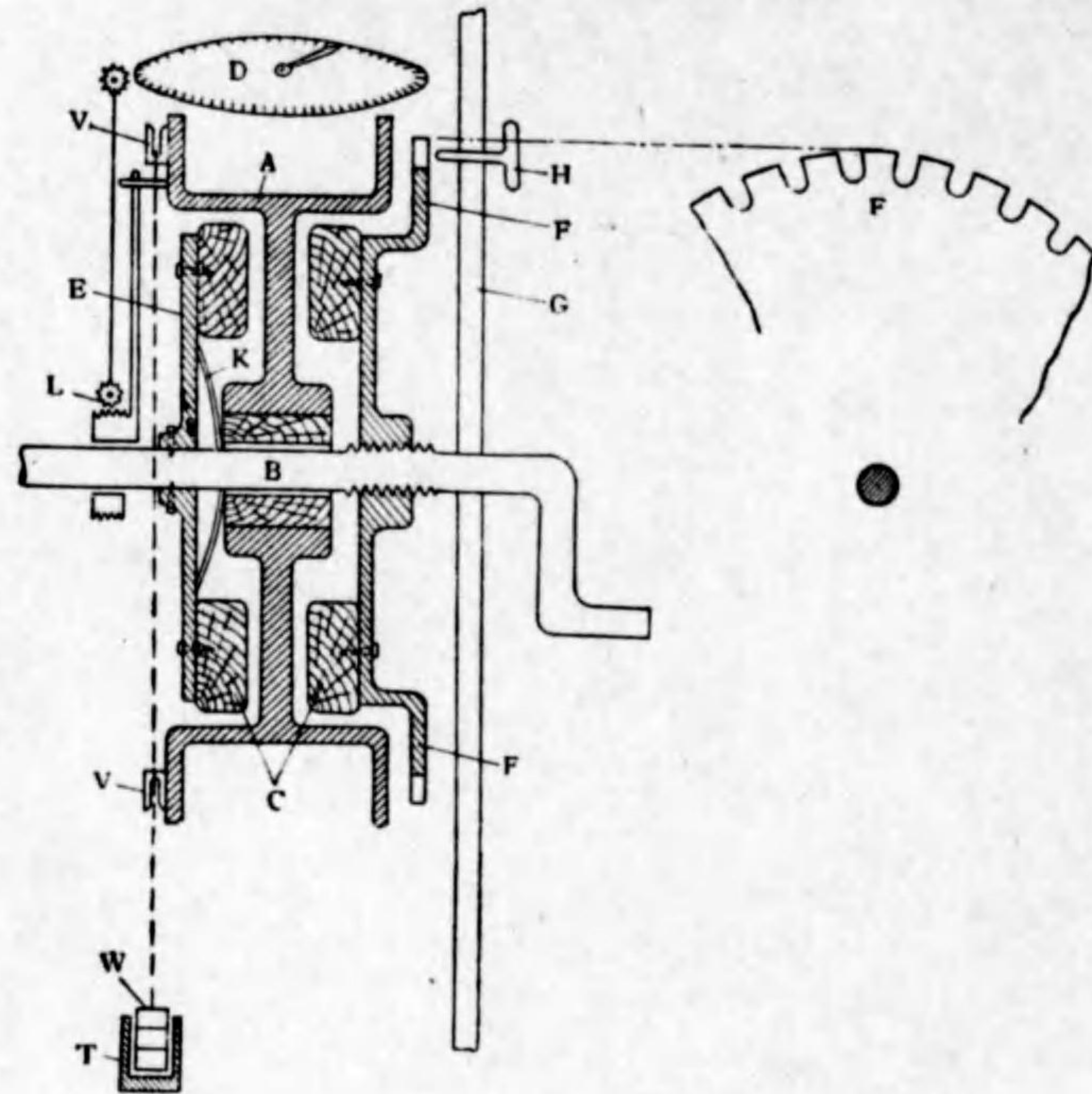

Fig. 4.
Lord Kelvin's mark IV
sounding machine.



Fig. 5.
Kelvin Mark IV Sounding machine.



- ADrum.
 BHorizontal axis.
 CLignum vitae.
 DDial.
 ECircular plate.
 FSprocket wheel.
 GFrame.
 HBrake catch pin.
 KSpring.
 LCounting gear.
 VV Shaped groove.
 WAutomatic brake weight & cord.
 T " " " tube.

Fig. 6.

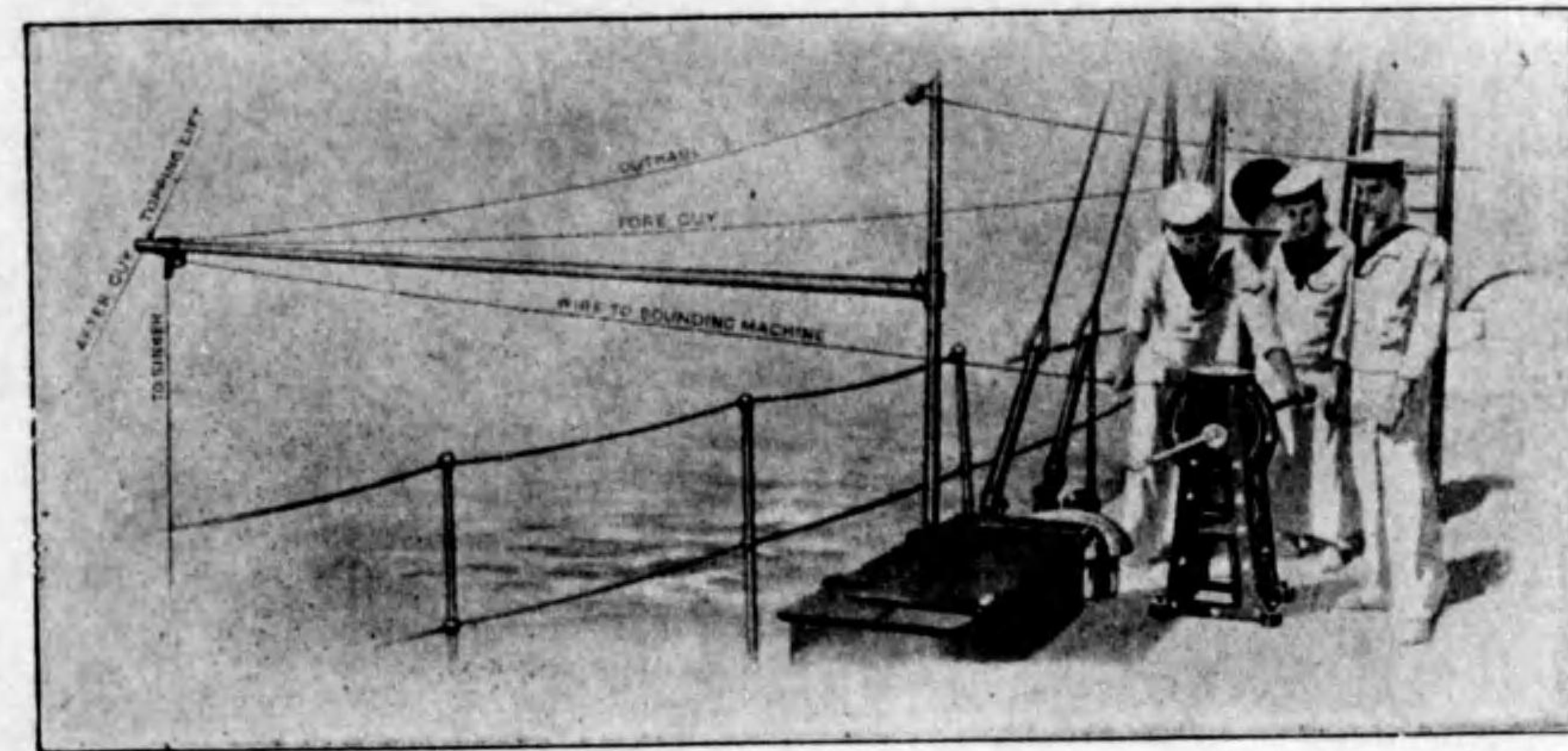

Fig. 7.

Large view of carrier and block.

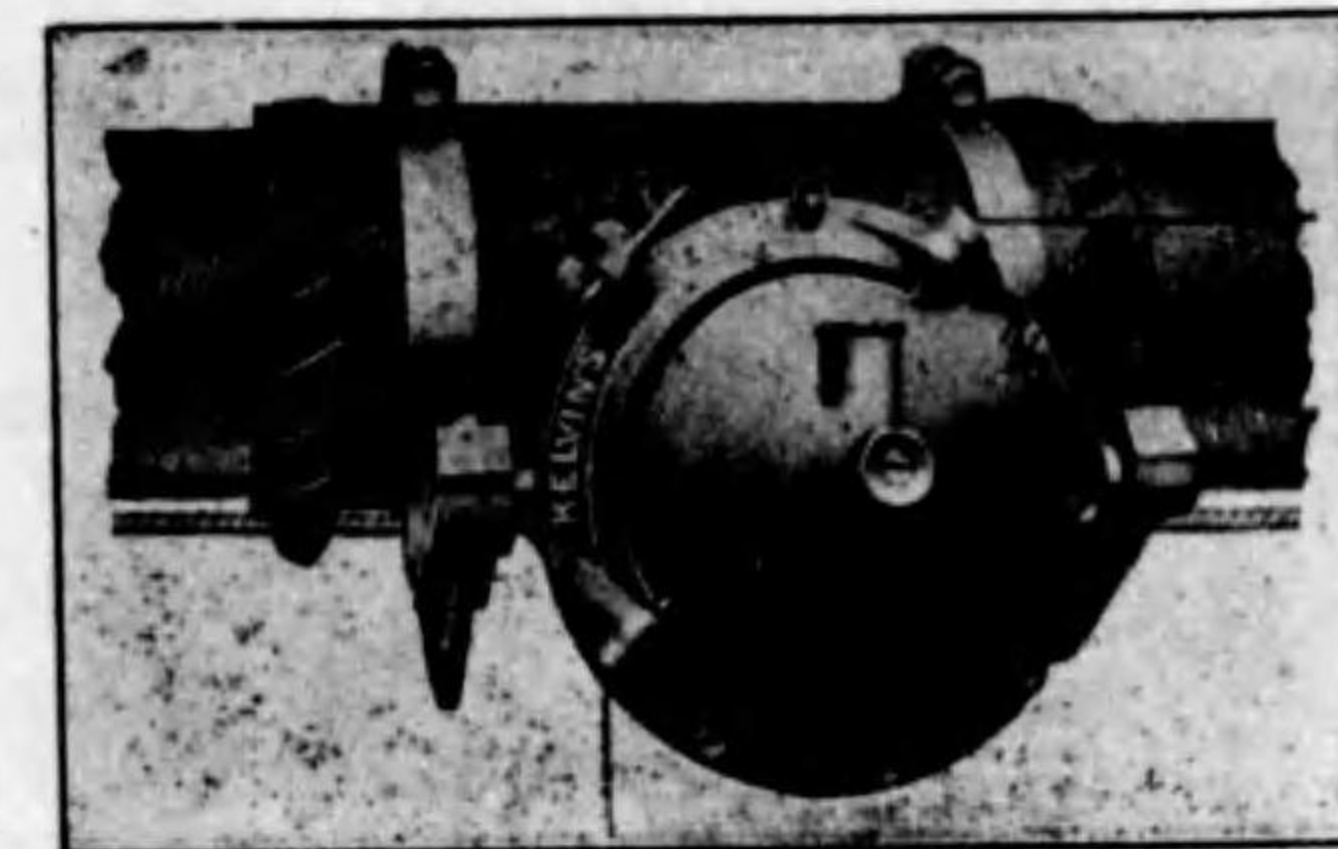

Fig. 8. B.
Motor sounding machine.Fig. 8. A.
Motor sounding machine.

Fig. 9.

Kelvin Motor Sounding Machine.

- A Frame. (外筐)
- B Counter. (指示器)
- C Motor casing. (電動機筐)
- D Spindle. (測深機軸)
- E Skelton wheel. (大車輪)
- F V" Shaped ring. (V字環)
- G Fixd circular plate. (固定圓板)
- H Ratchet wheel. (棘齒車)
- I Bevel wheel. (斜齒車)
- J Spring. (皿狀發條線)
- K Steel ball. (鋼球)
- L Wooden check. (木製輪)
- M Handle. (把柄)
- N Magnetic silencer. (電磁消音器)
- O Junction box. (接續筐)
- P Push for silencer. (電路接續突子)
- Q Lamp. (電燈)
- R Motor. (電動機)
- S Controller. (電動機用發停器)
- T Switch for lamp. (電燈接斷器)
- U Nut. (母螺)
- X Stop on bevel wheel. (斜齒車突起片)
- Y Stop on ratchet wheel. (棘齒車突起片)
- Z Traugh. (鋼球受金)

Fig. 10.
Wiring diagram of motor sounding machine.

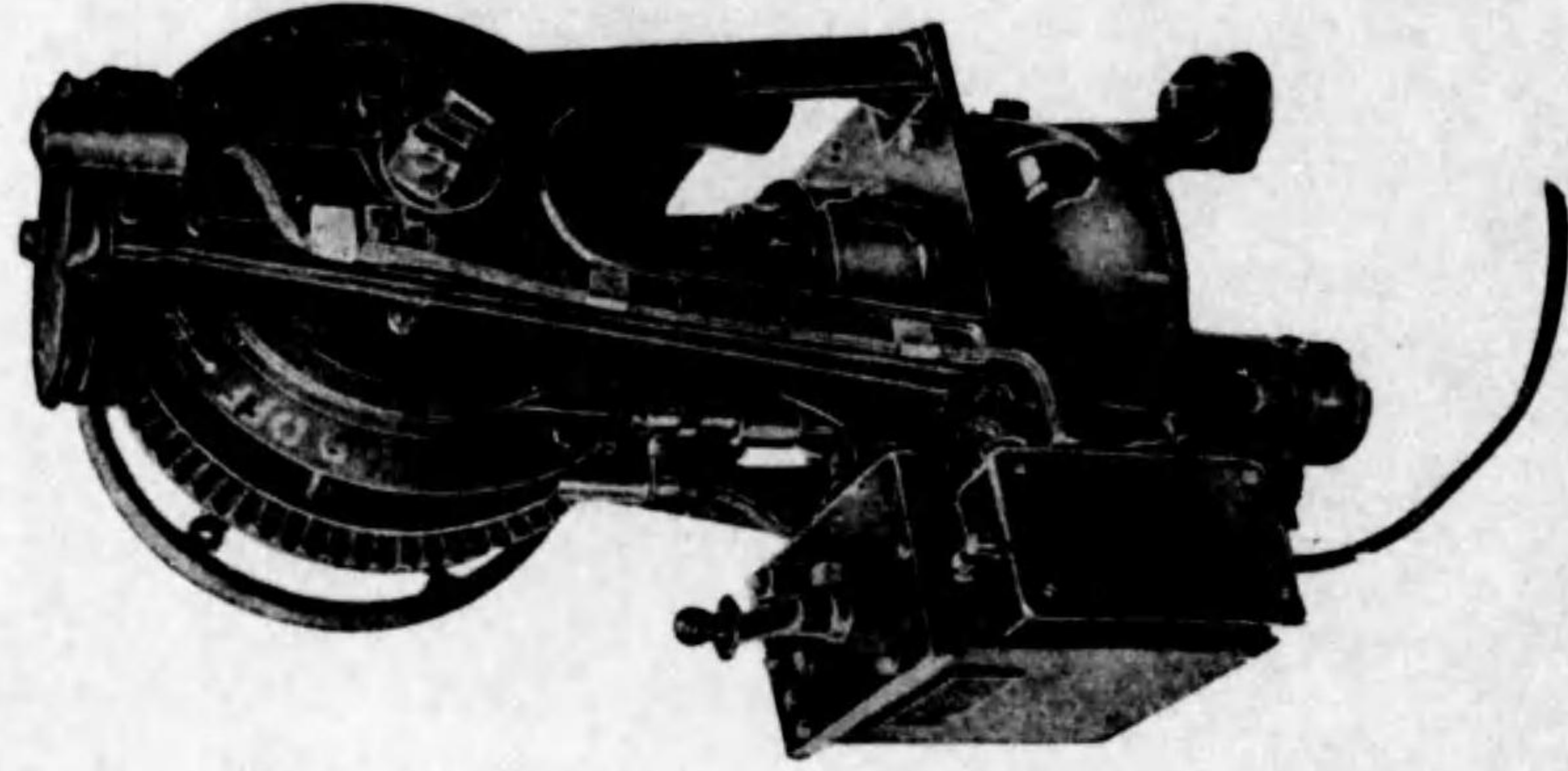
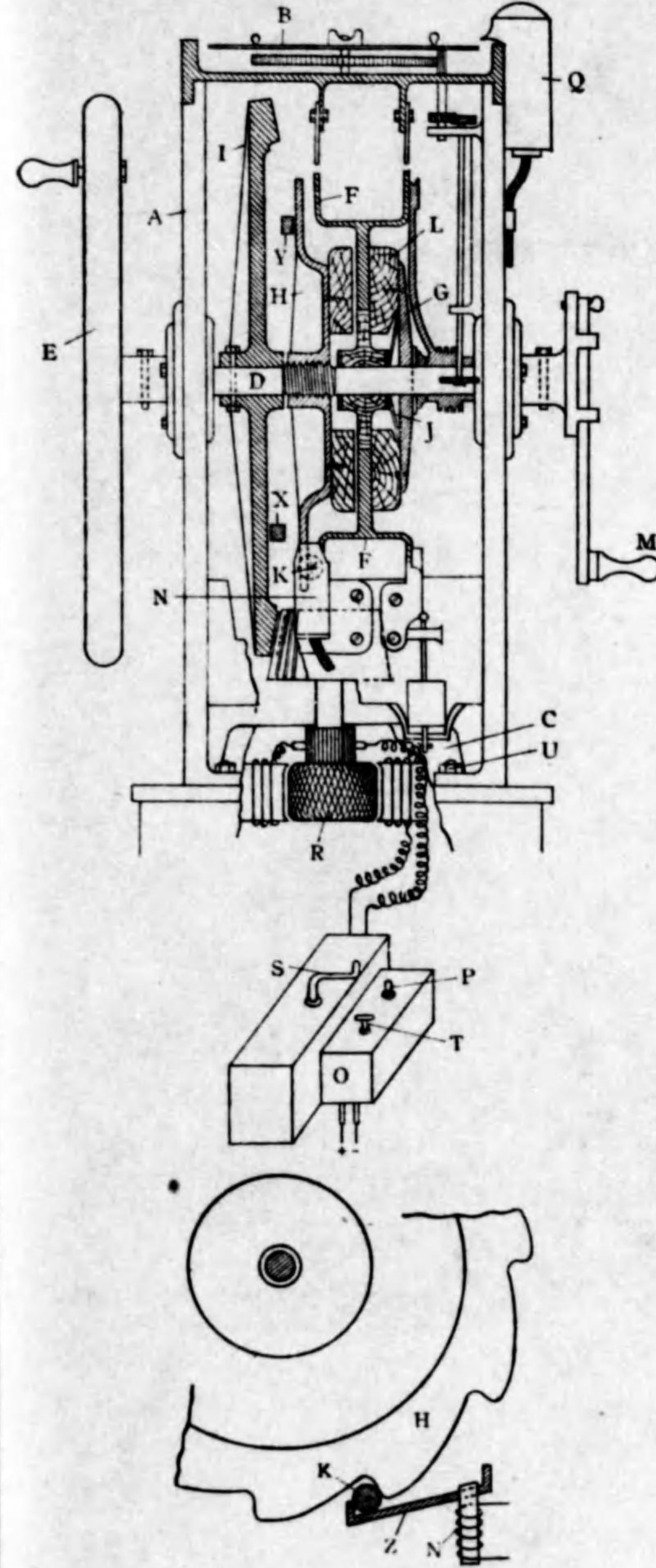
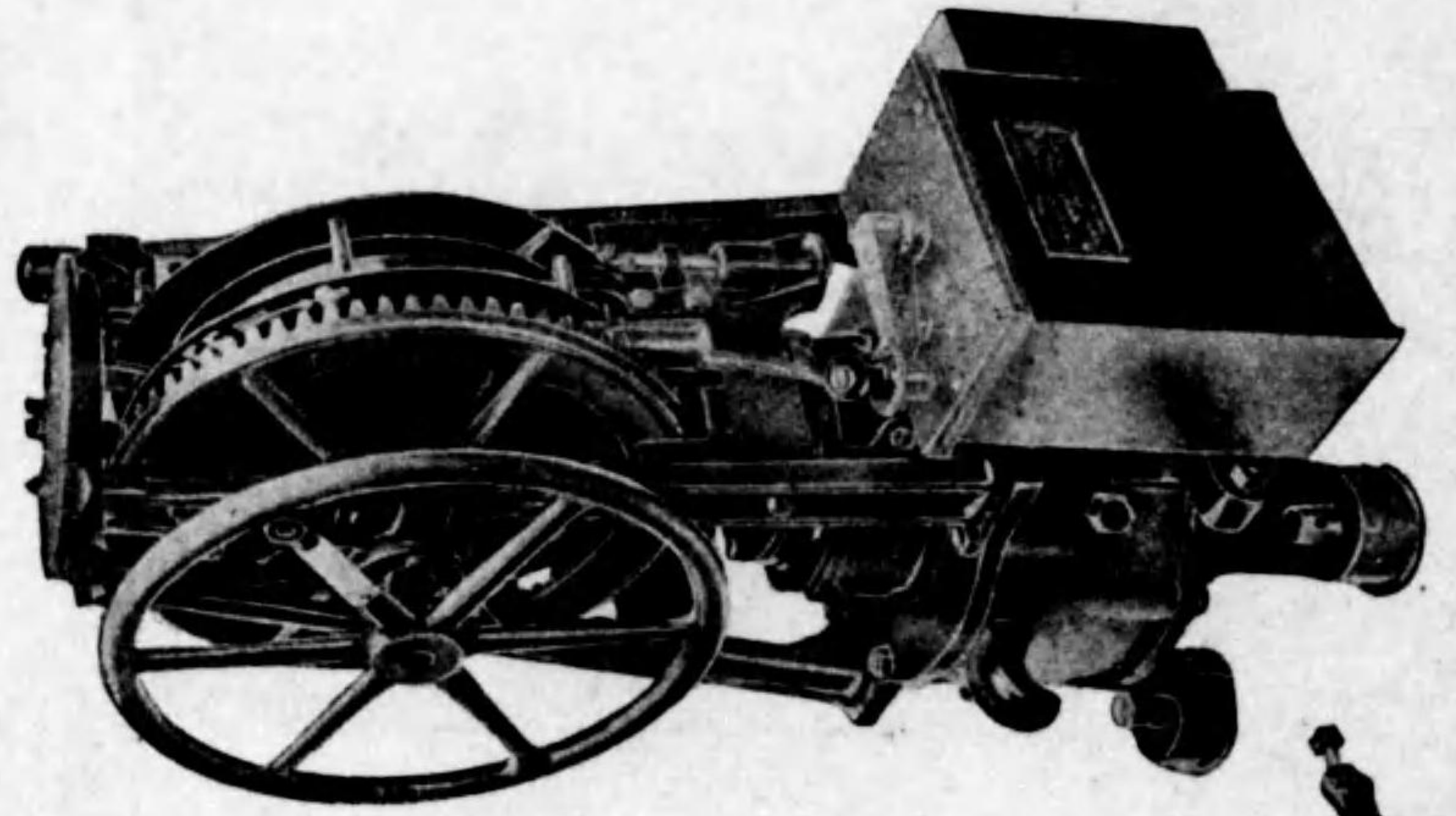
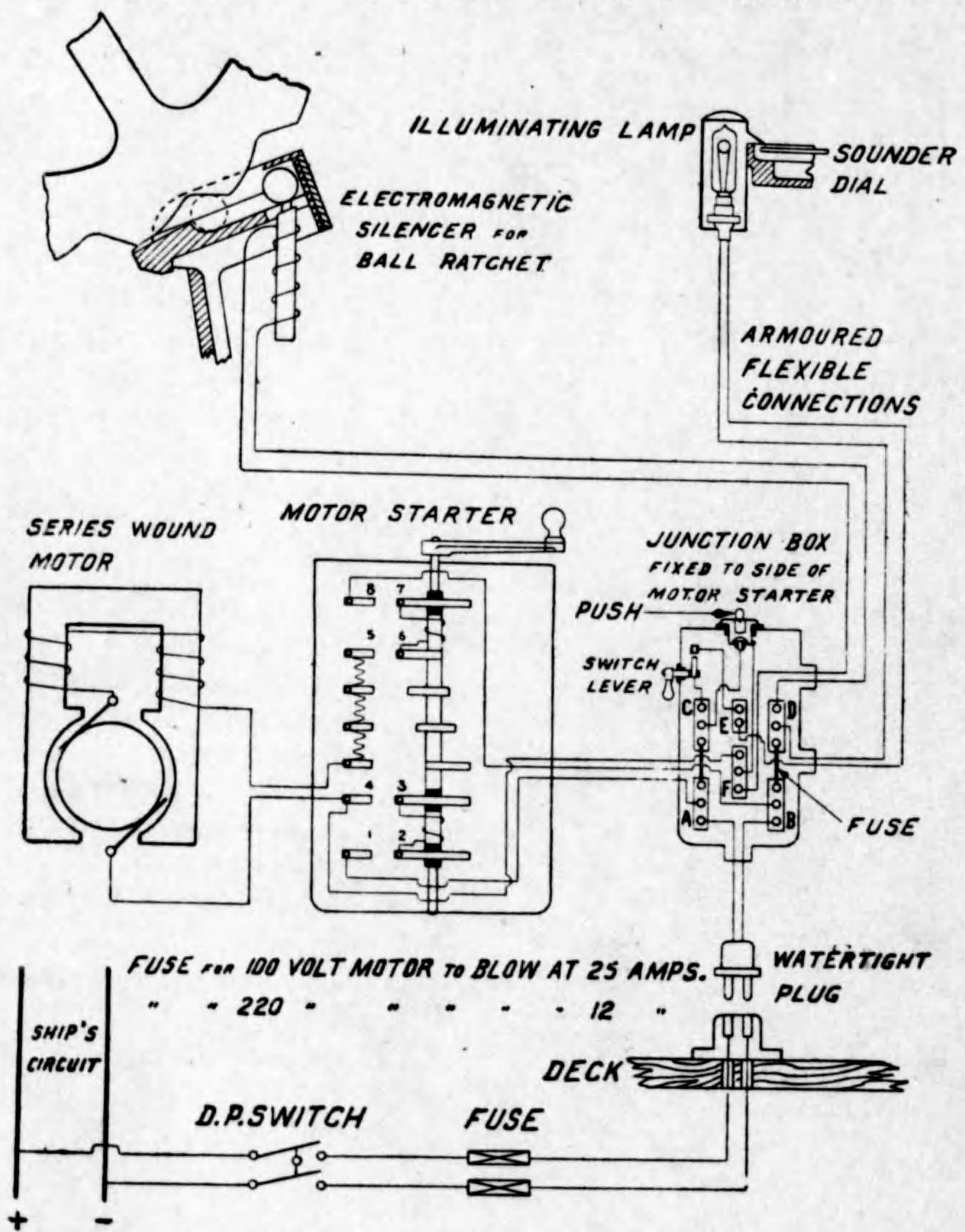

Fig. 11.
Arrangement of gear to take sounding from forward bridge.

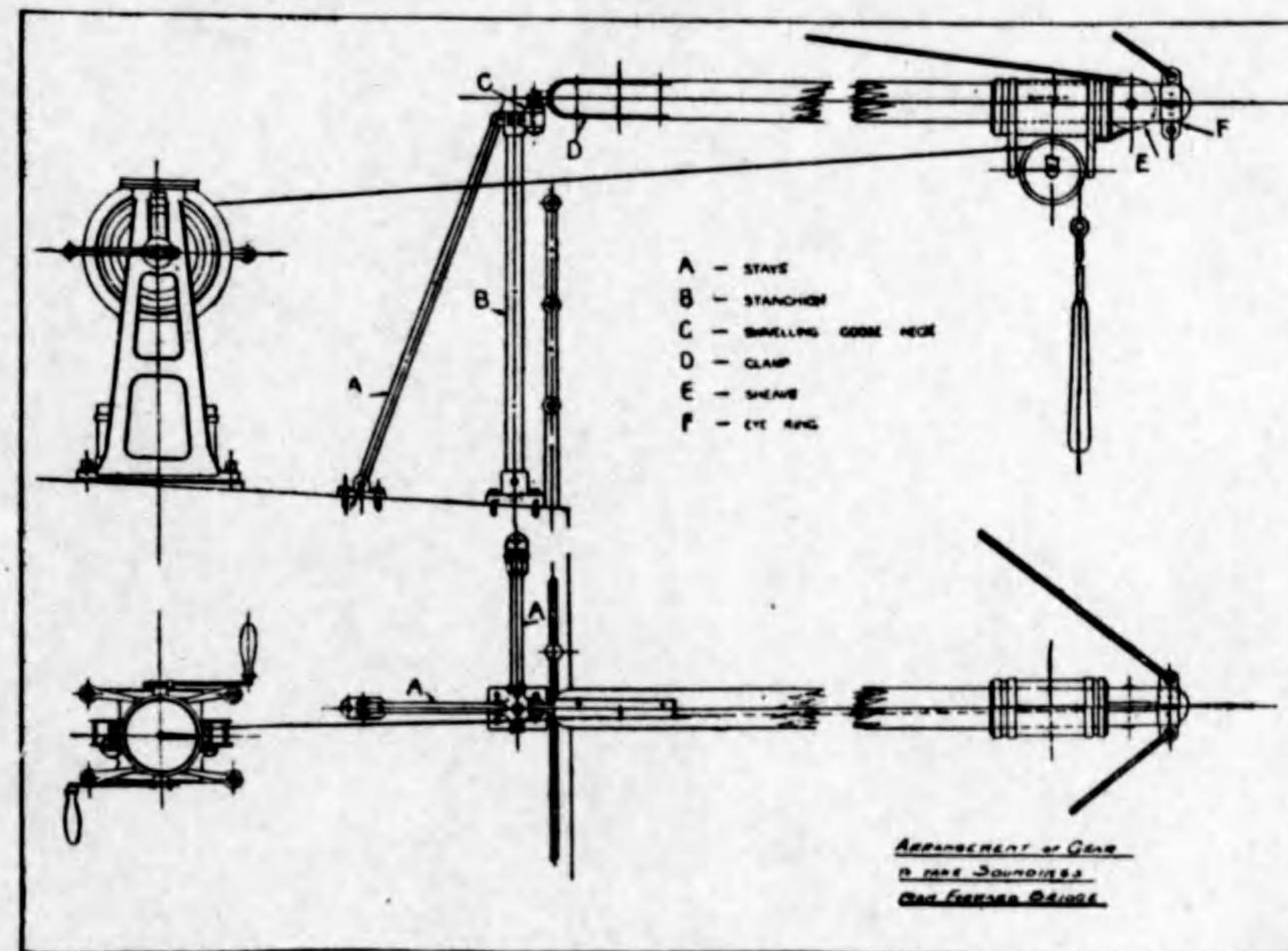

Fig. 12.
Husun sounding machine.



Fig. 1.
Sextant.

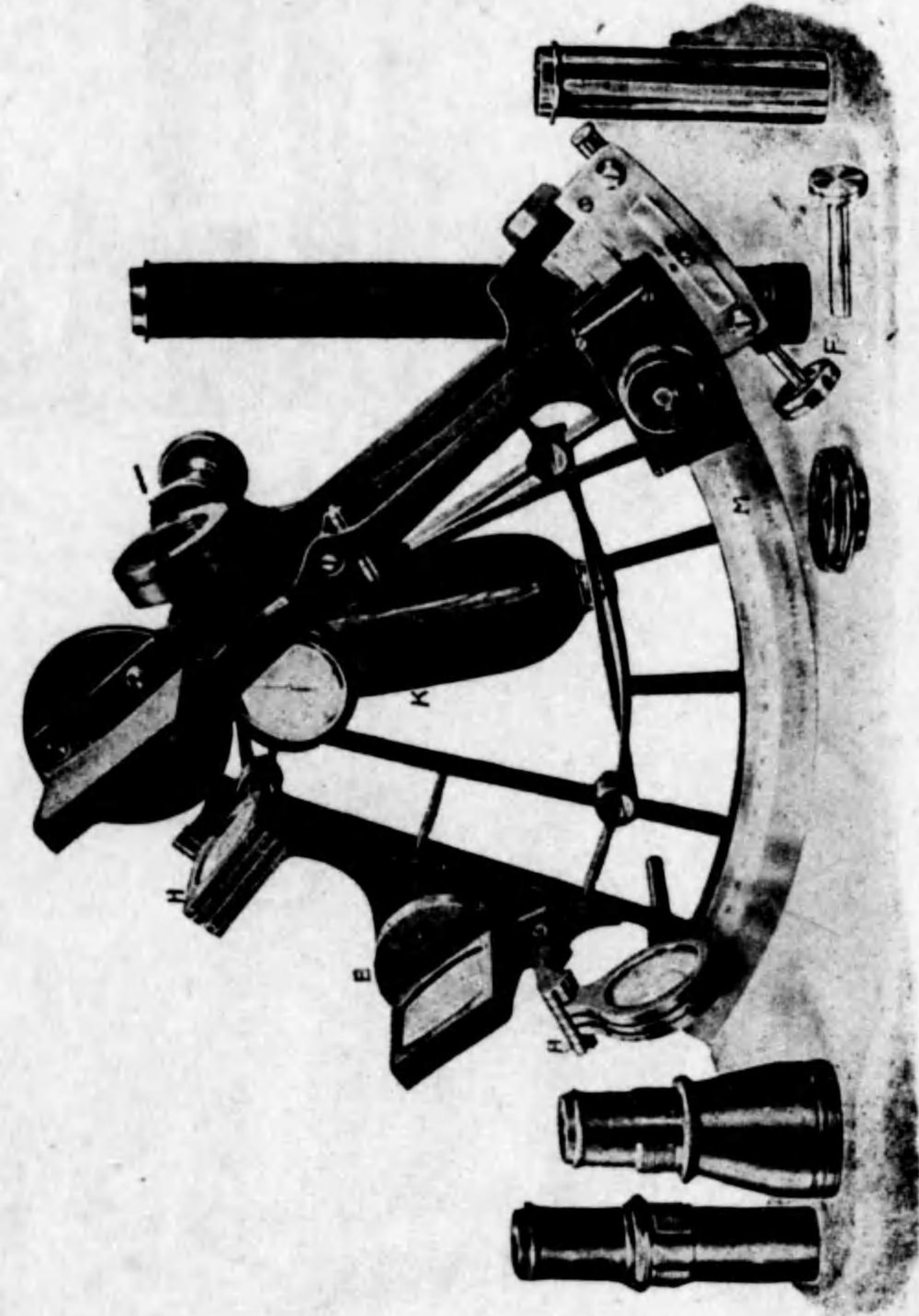

Fig. 2.
Sextant Telescopes.

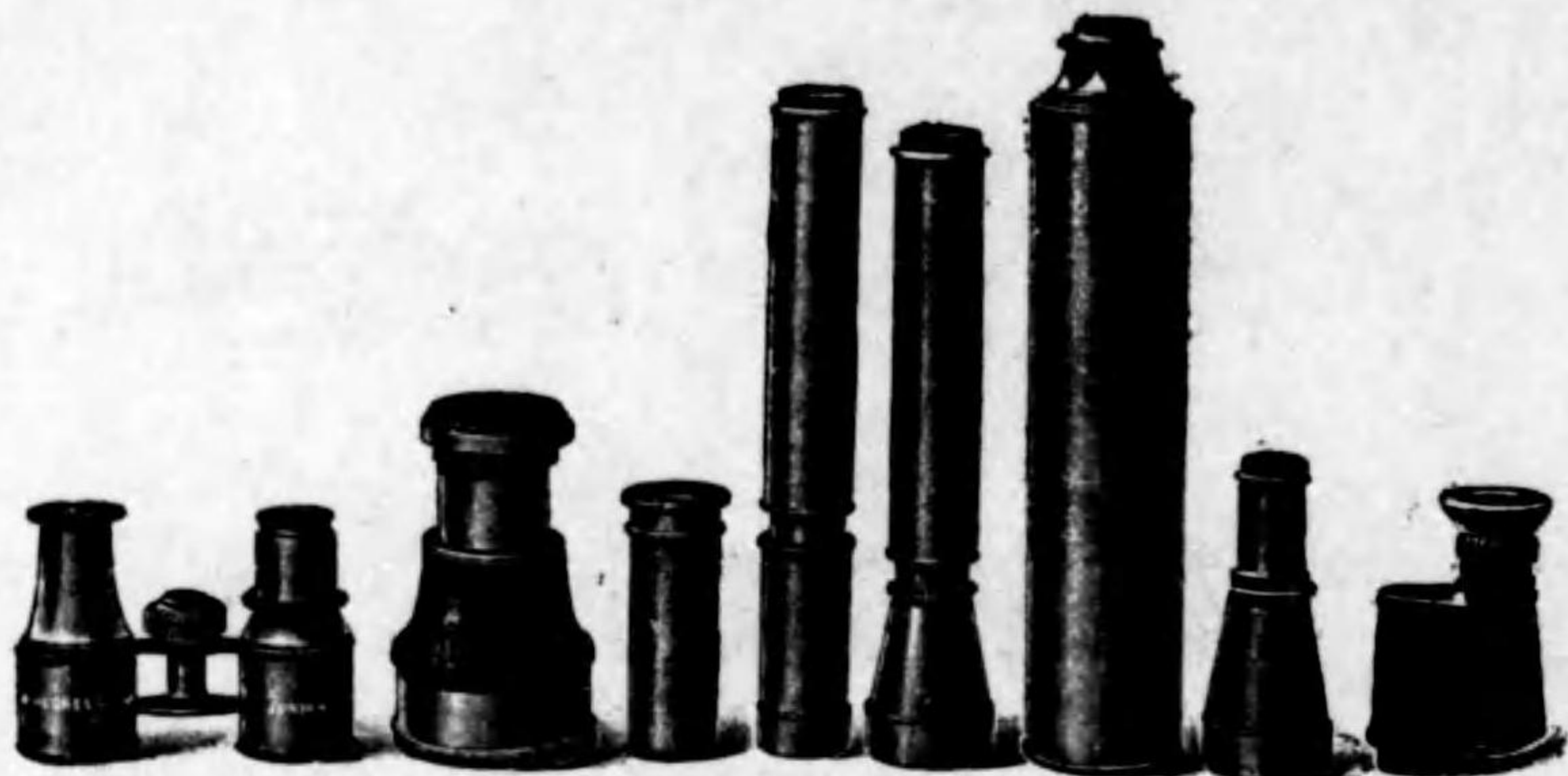

Fig. 3.
Diagram of Sextant.

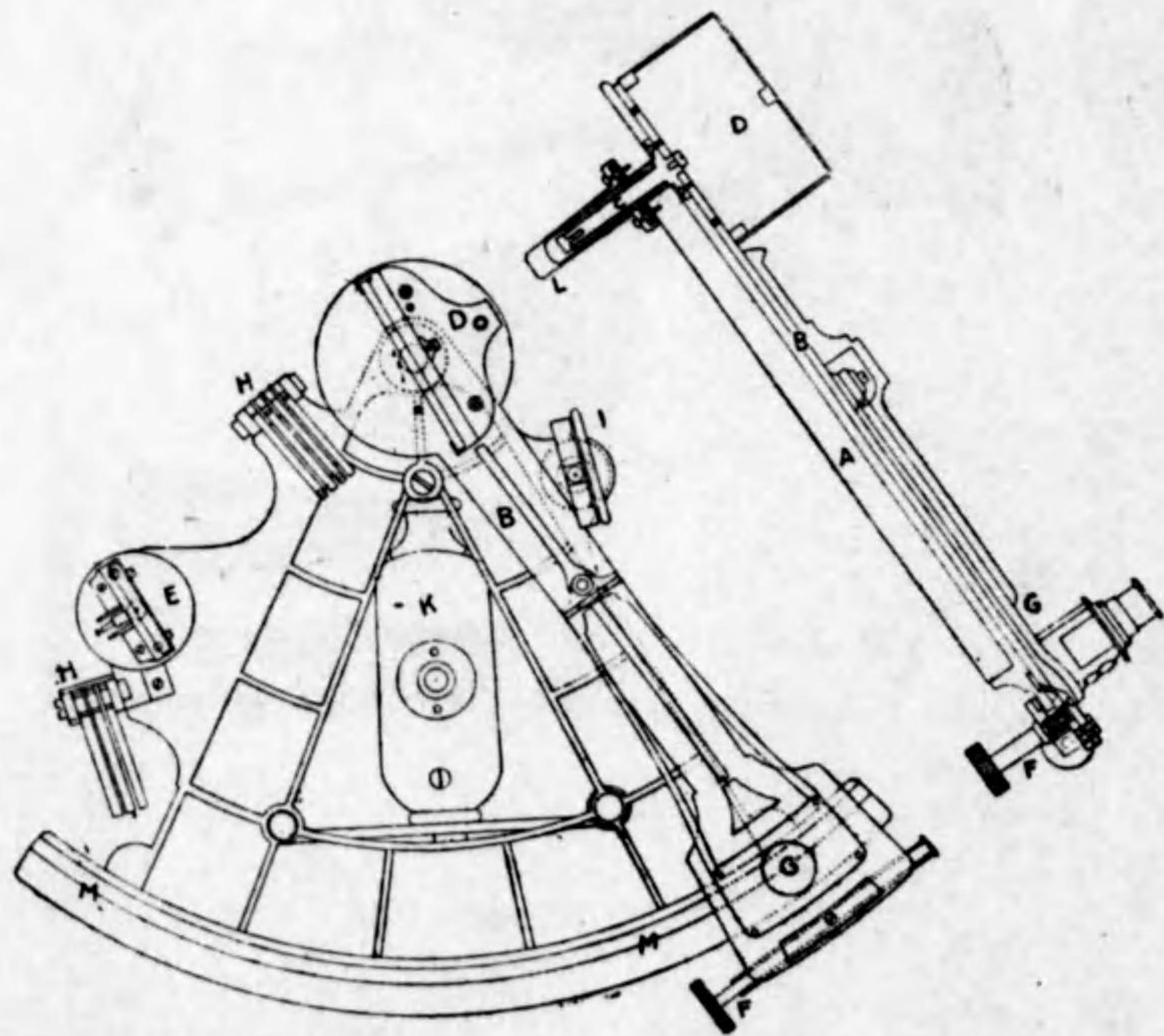

Fig. 4.

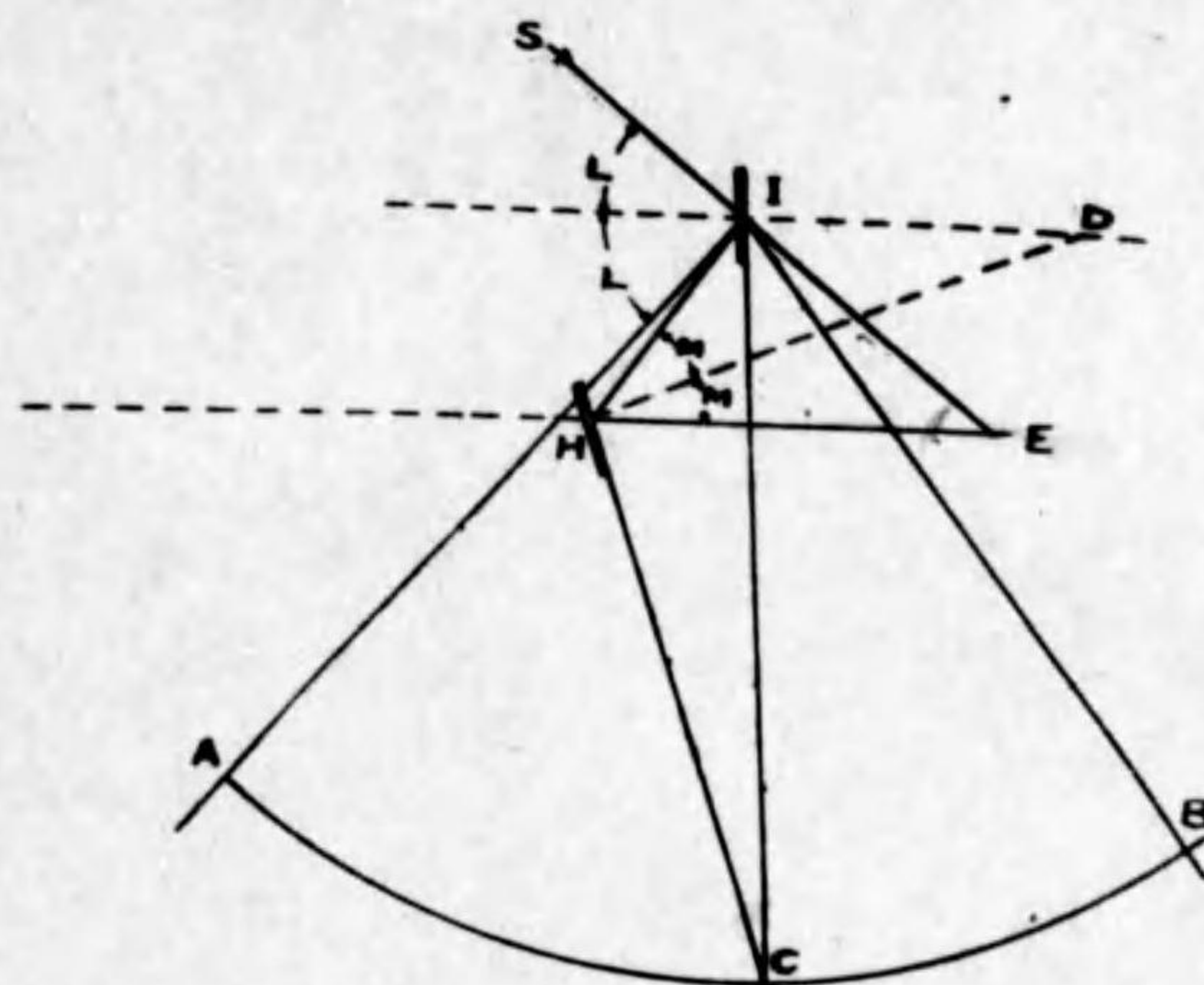

Fig. 5.

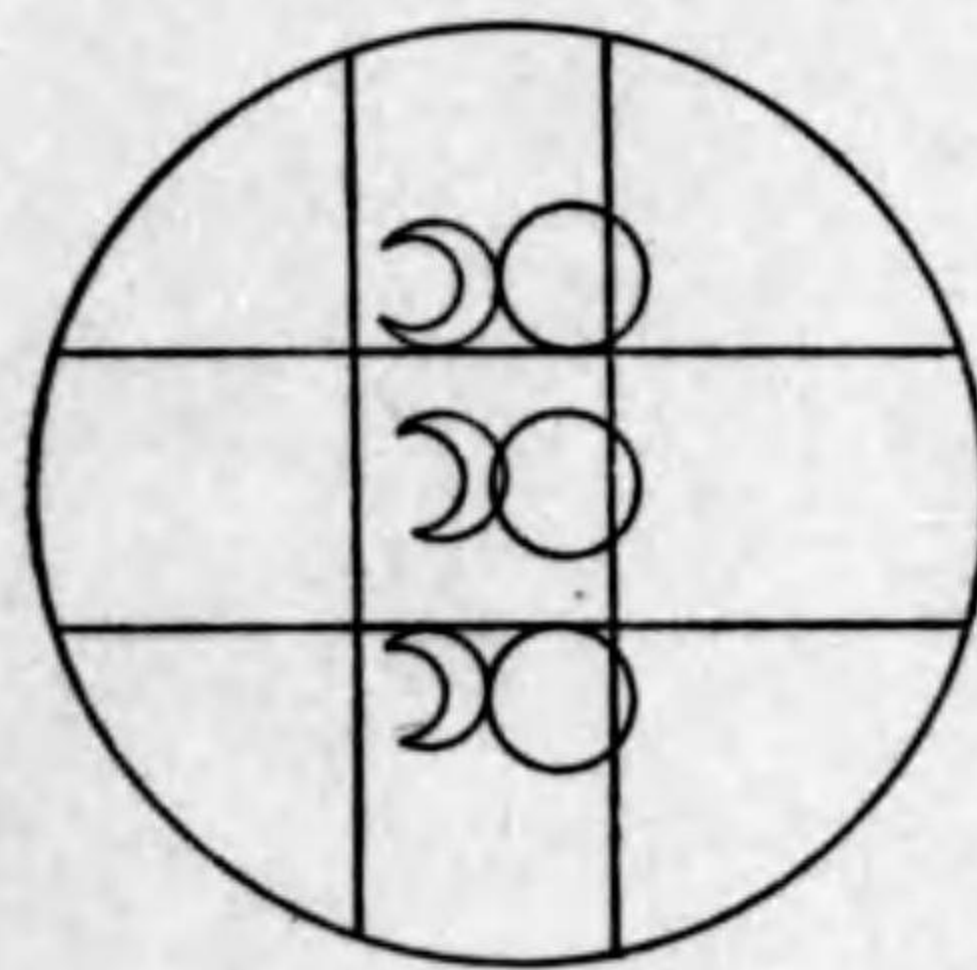

Fig. 6.

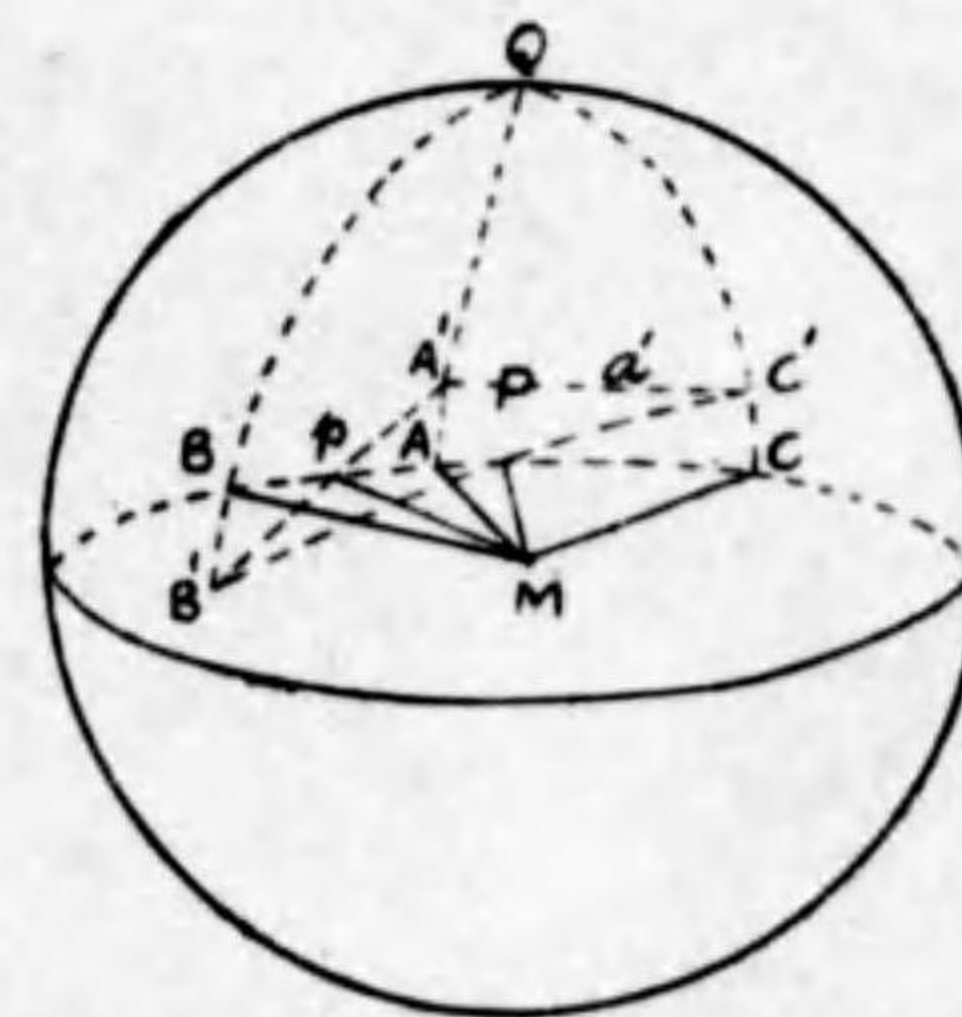

Fig. 7.

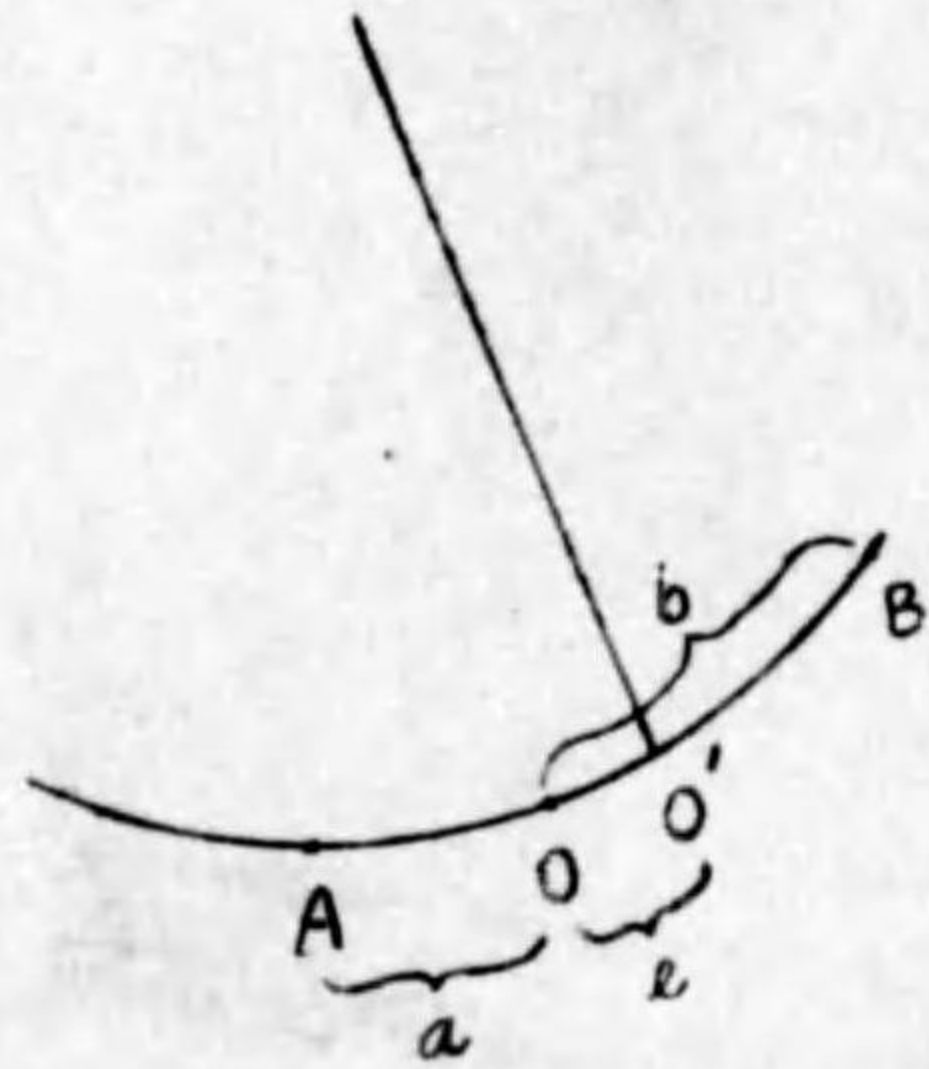

Fig. 8.

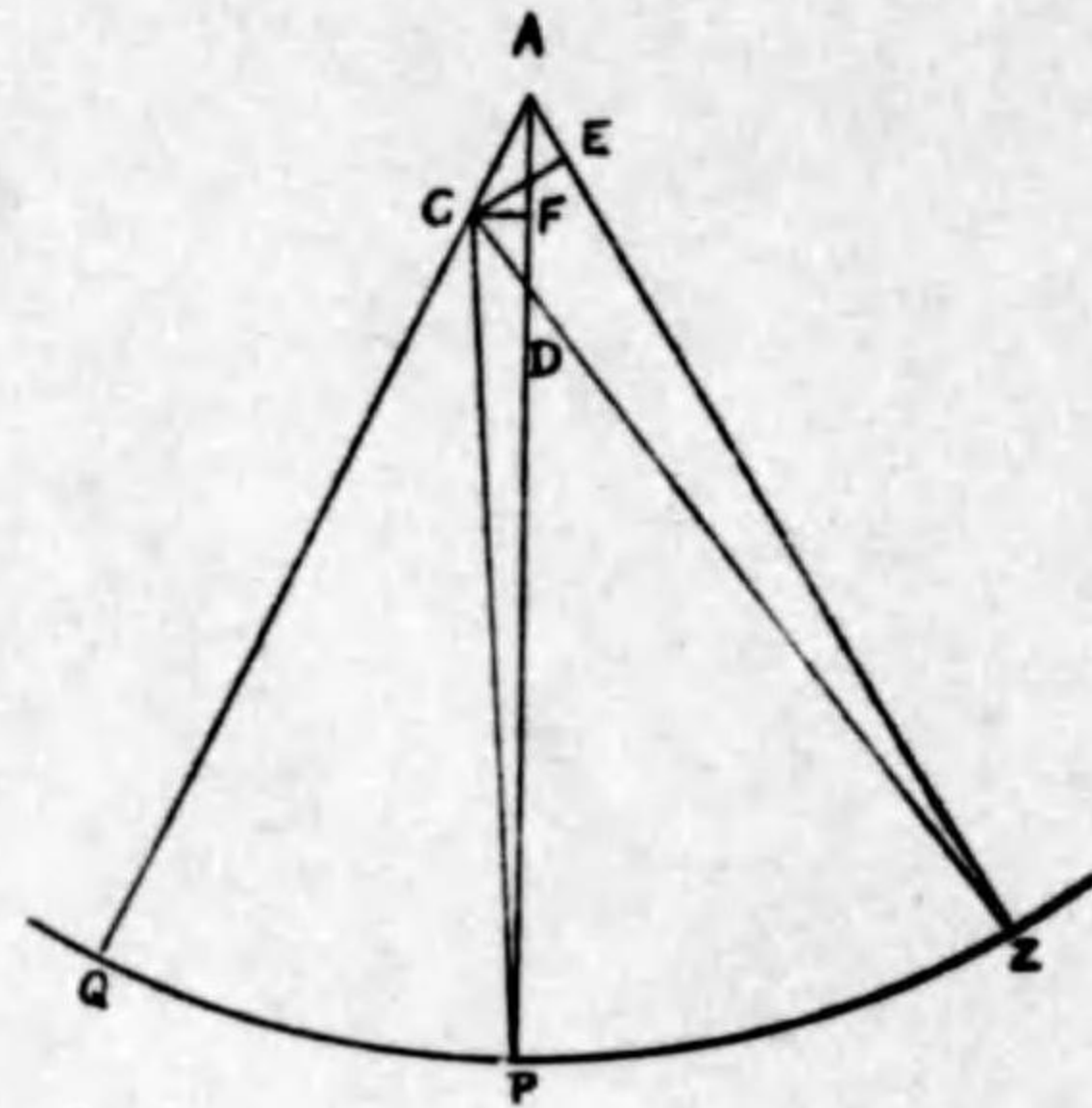

Fig. 9.

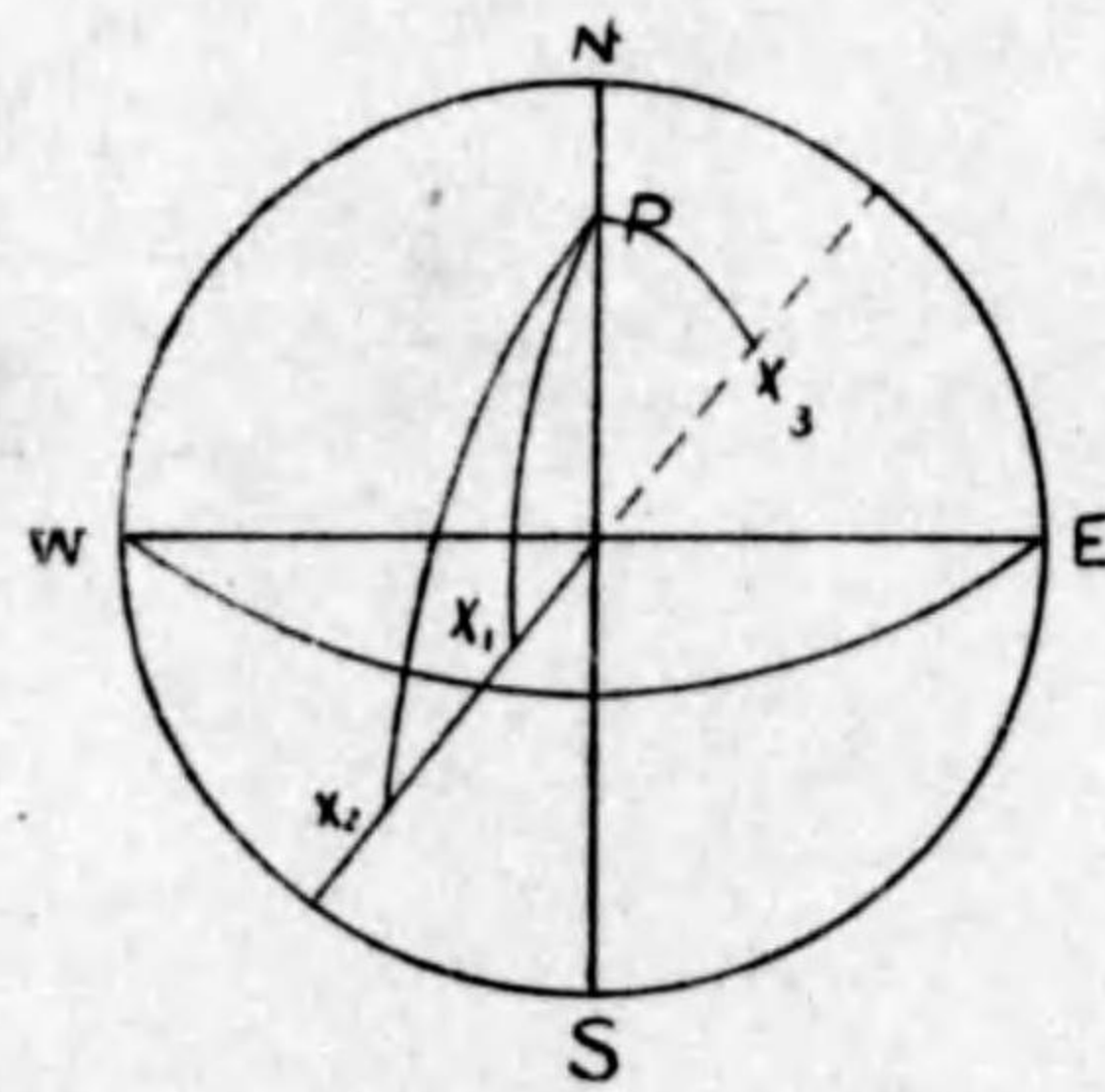

Fig. 10.
Sextant with Recording Arc.

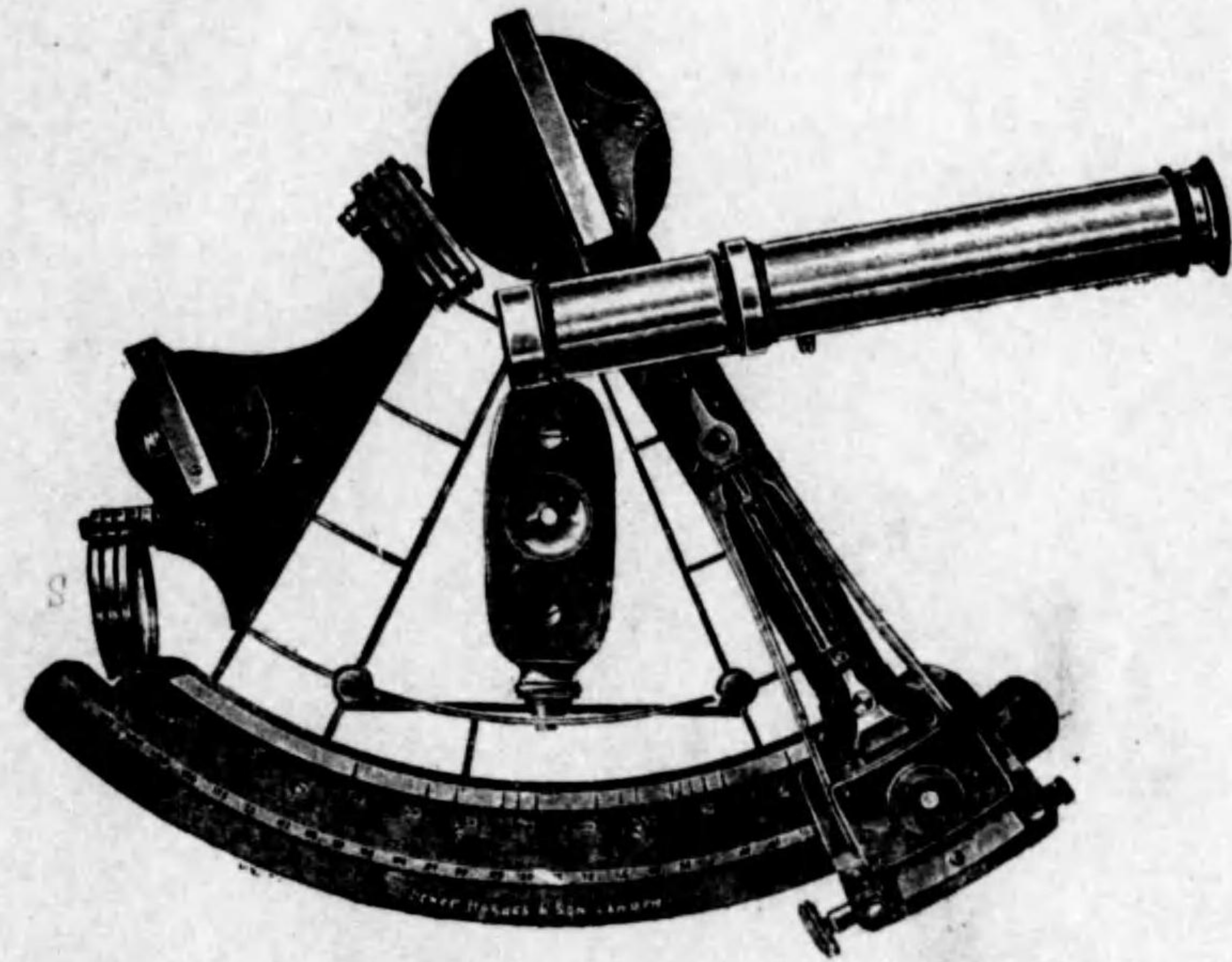

Fig. 1.
Principle of the Artificial Horizon.

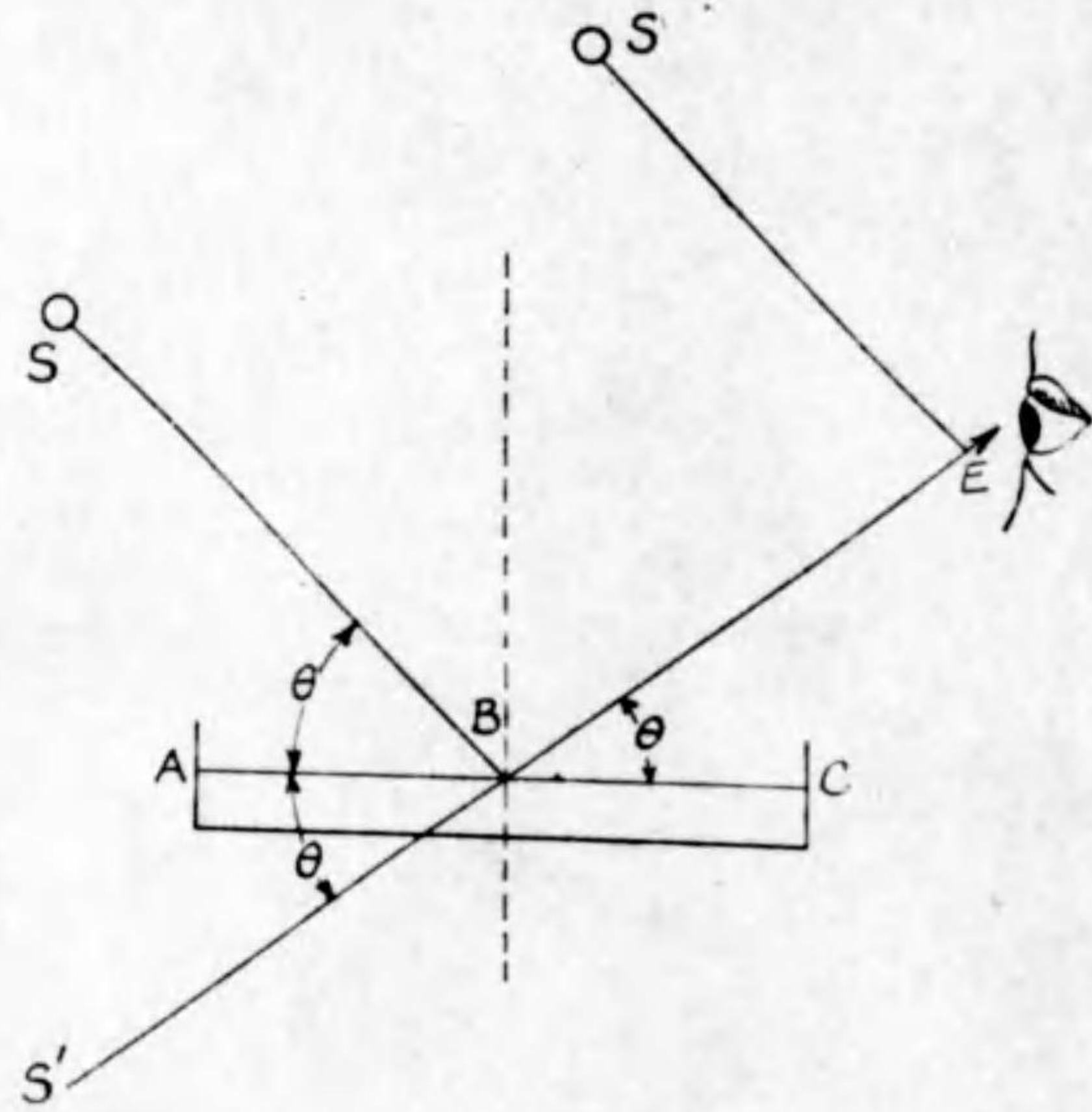

Fig. 2.



- (1) Roof.
- (2) Through.
- (3) Botrle.
- (4) Plug.
- (5) Cone.

Fig. 2.

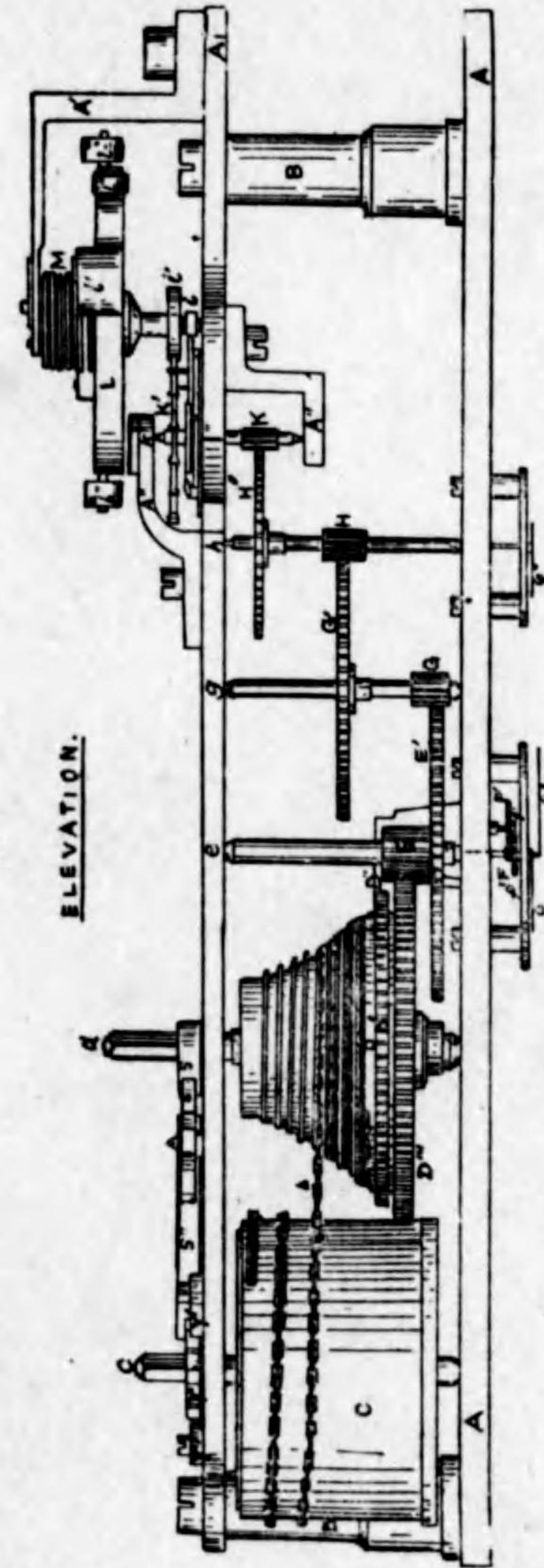

Fig. 3.

P L A M.

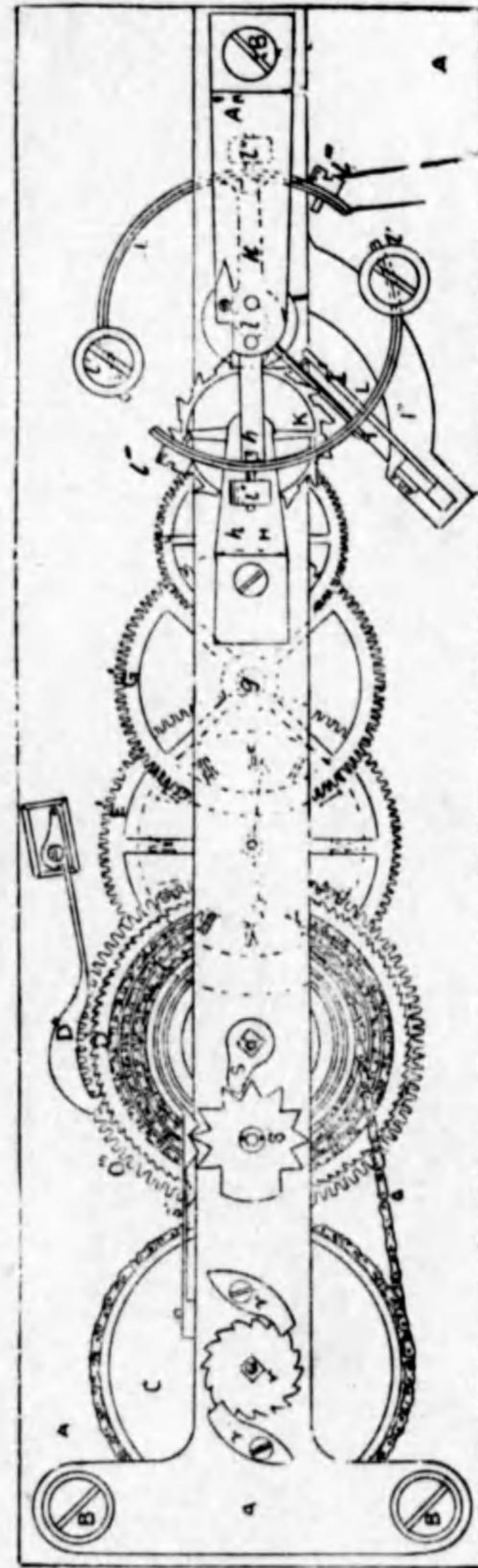

Fig. 4.
The Maintaining Mechanism.



Fig. 5.
The Escapement.

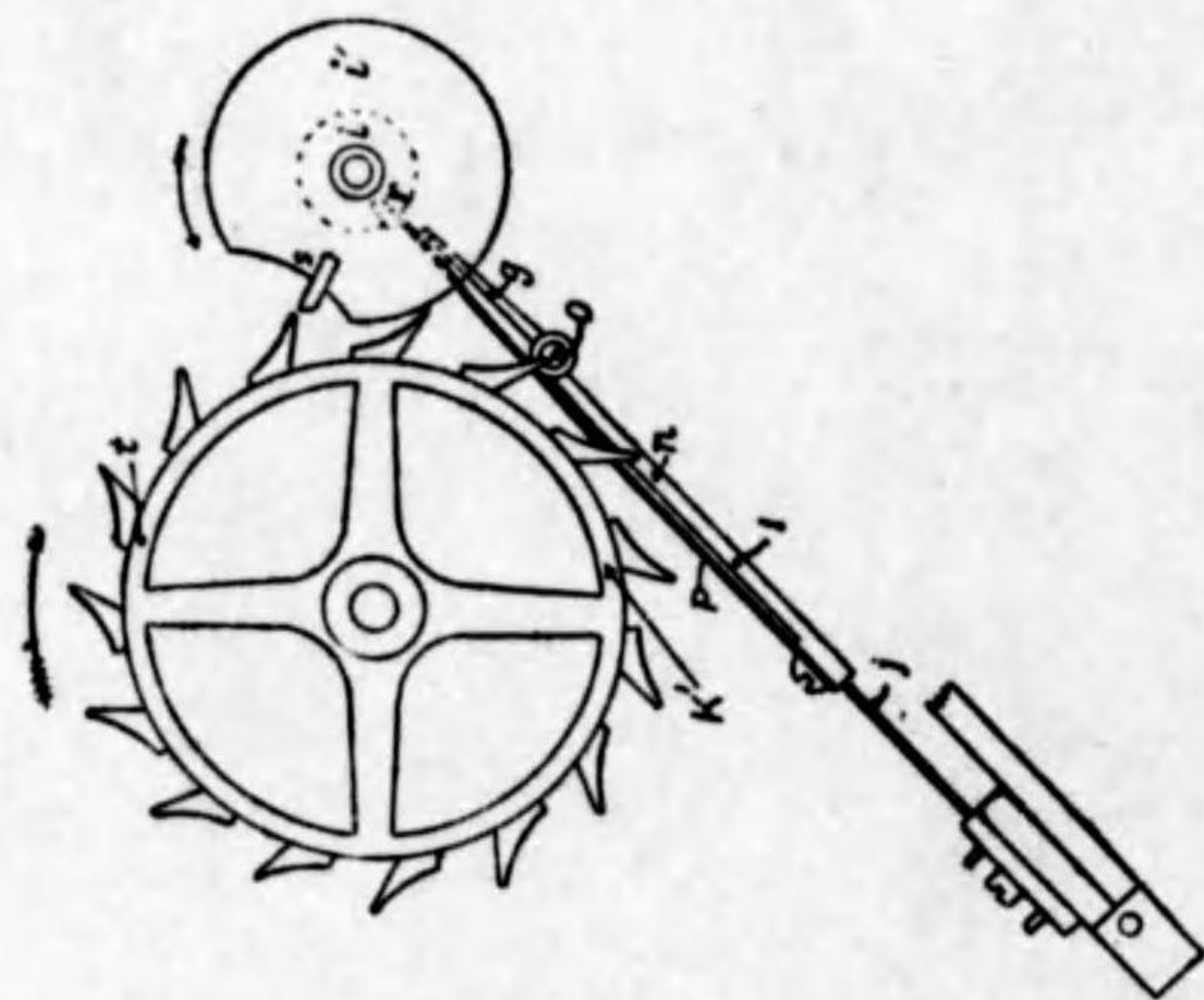

Fig. 6.
The Motion Work.

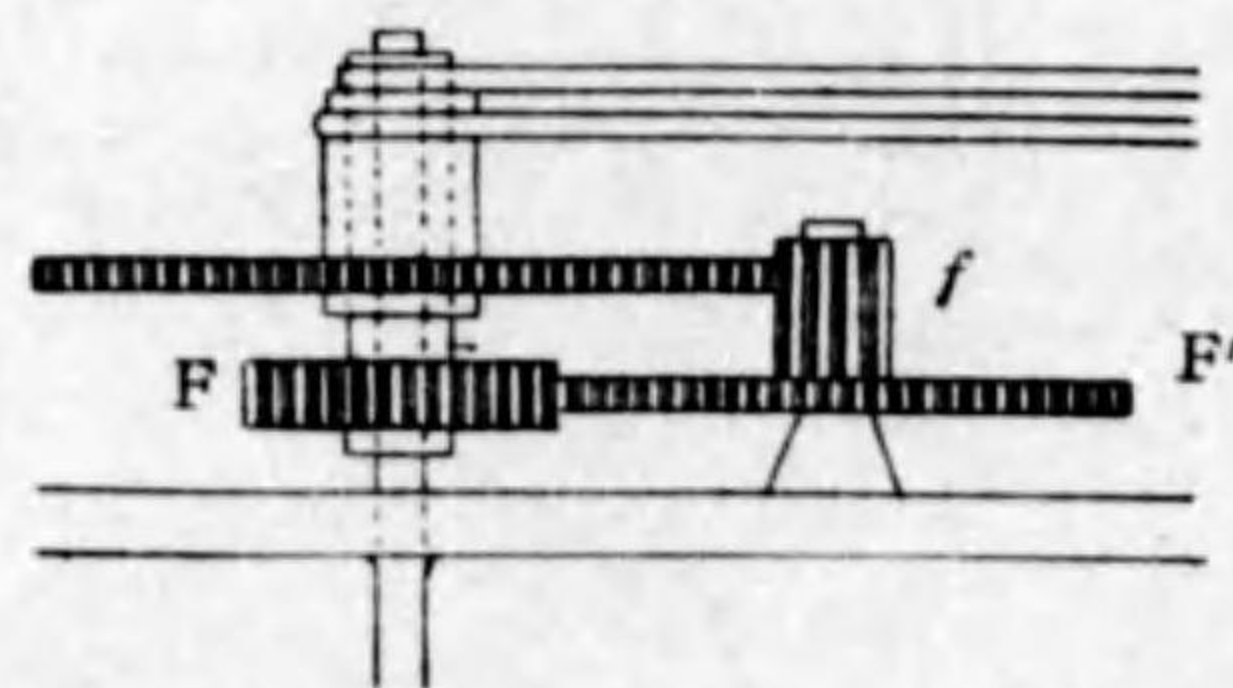

Fig. 7.
The chronometer Box.

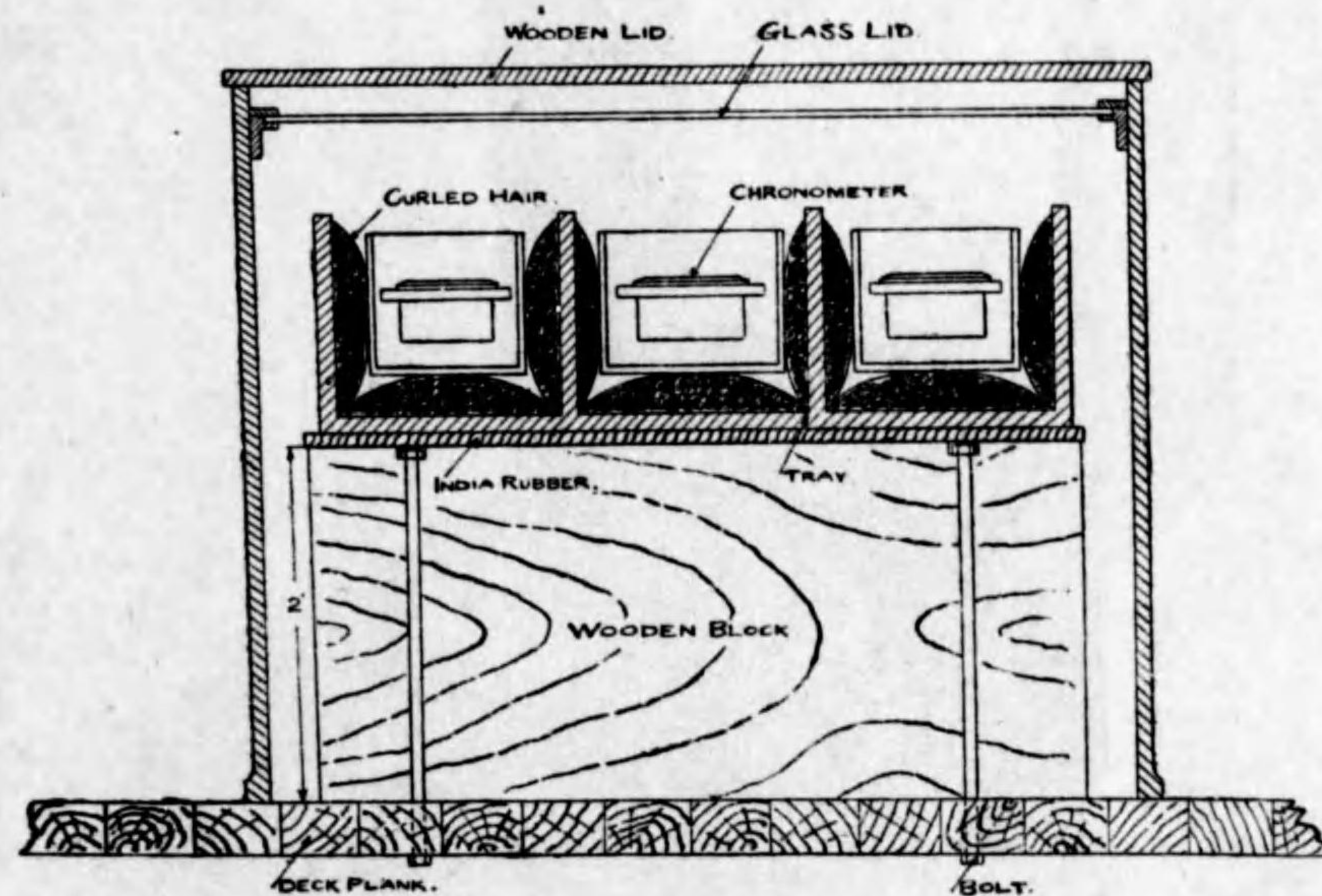

Fig. 8.
Marine Chronometer.



Fig. 1.

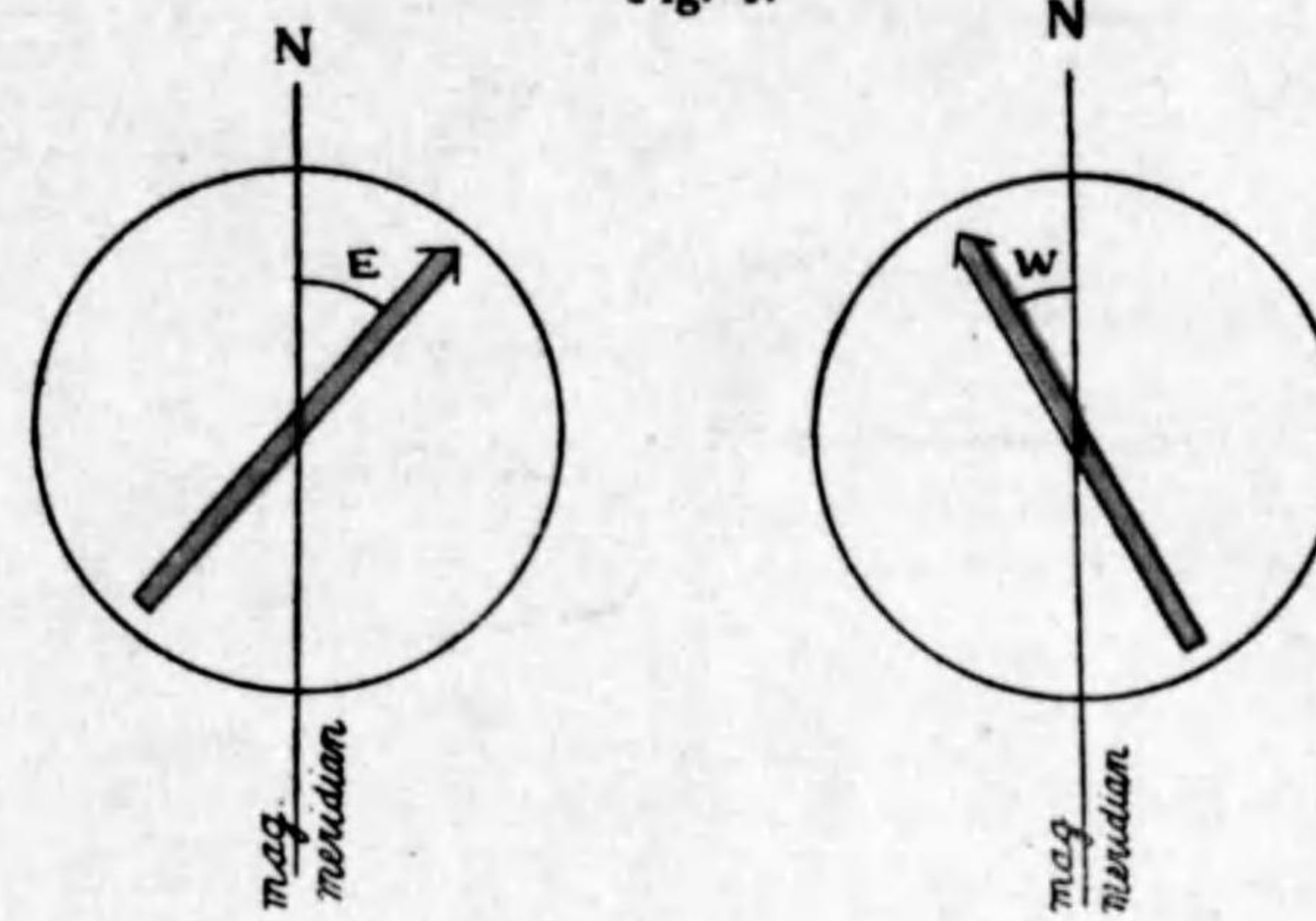

Fig. 2.

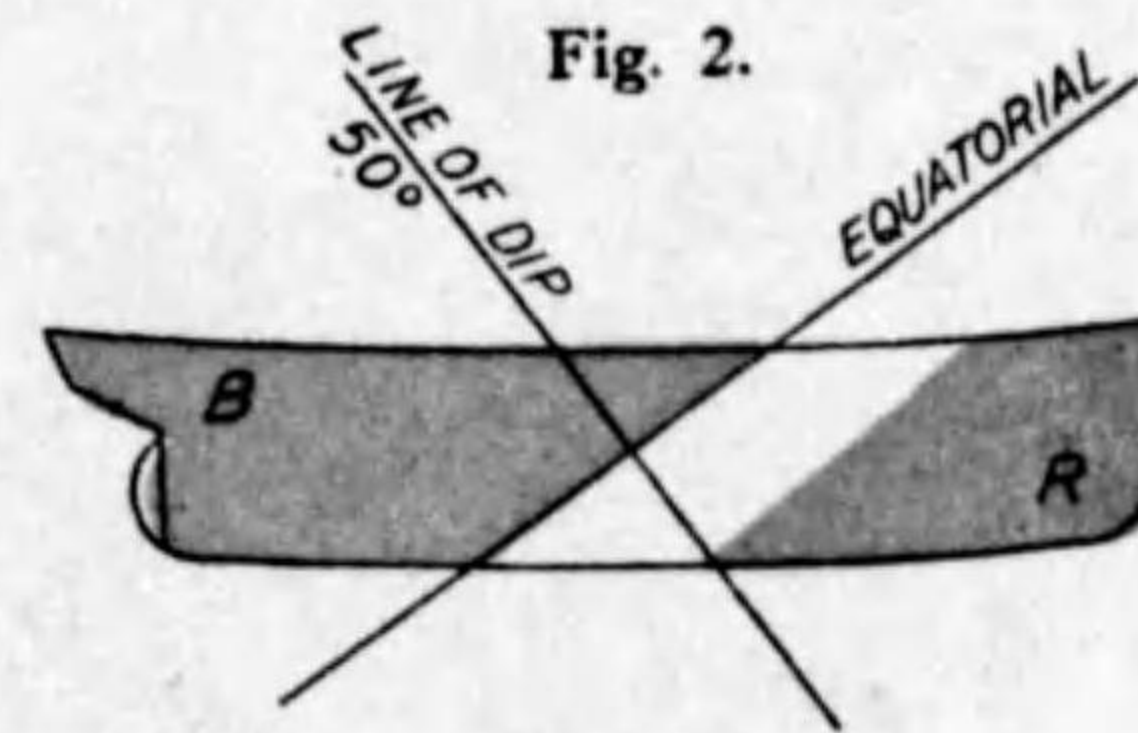
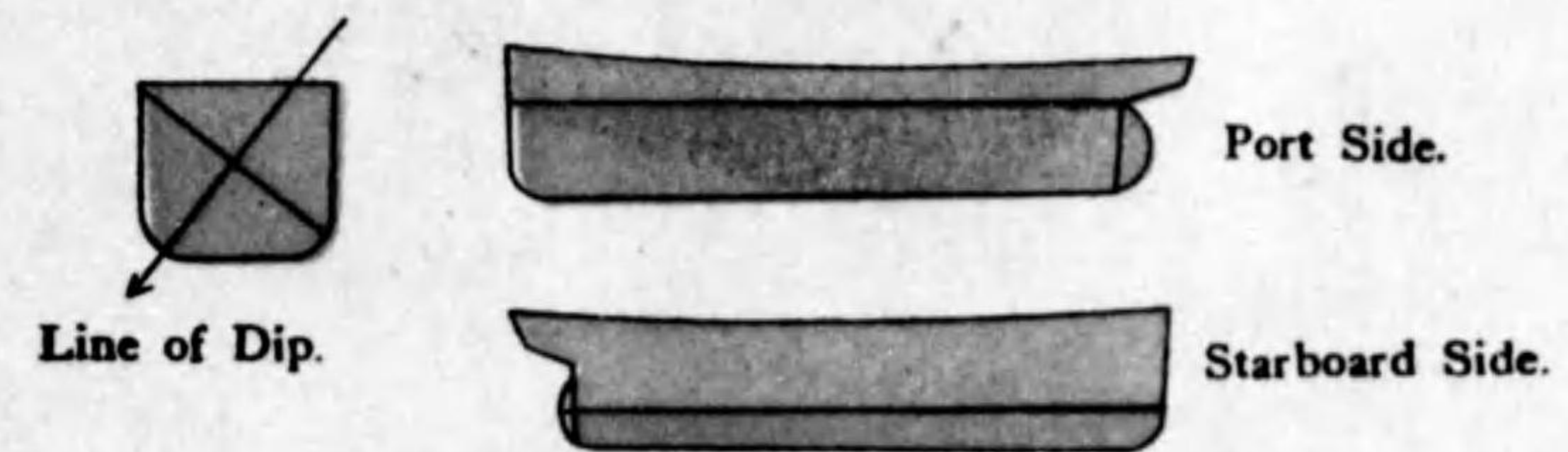

Fig. 3.

Ship built head East in Japan Dip 50°.



58 Fig. 4.
Ship built head South West in Japan.

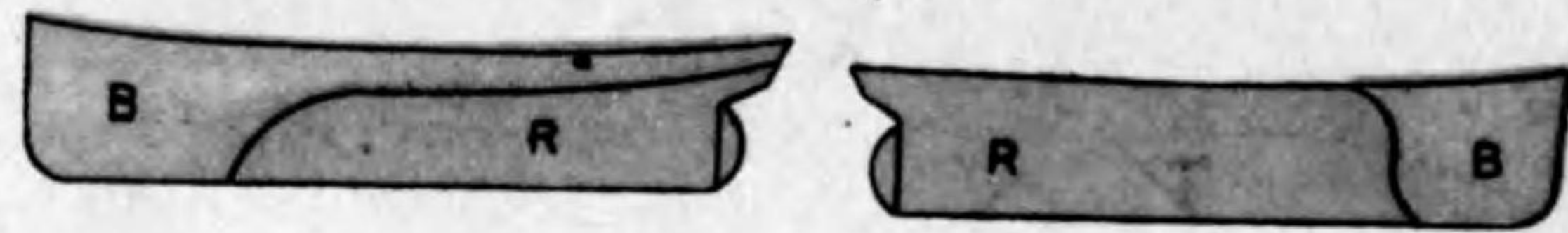

Fig. 5
Ship built head North on the Magnetic Equator.

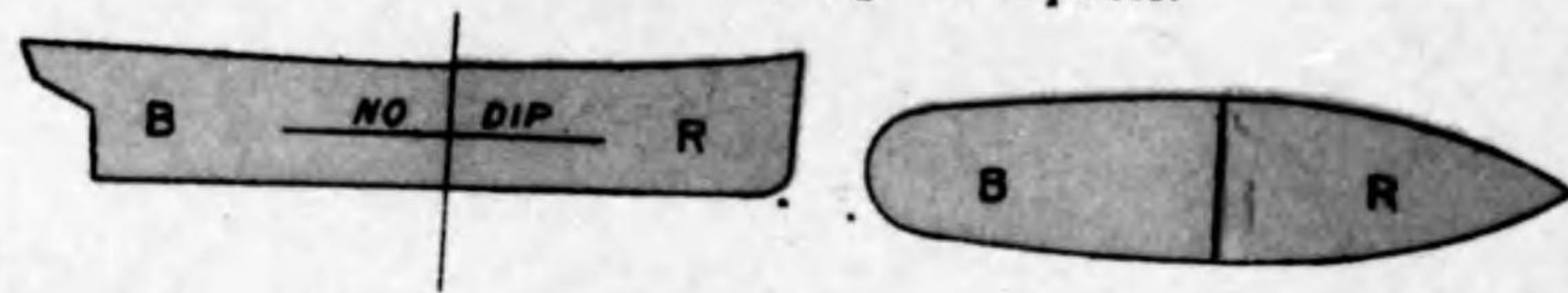

Fig. 6.
Ship built head North at Sydney (N.S.W.)

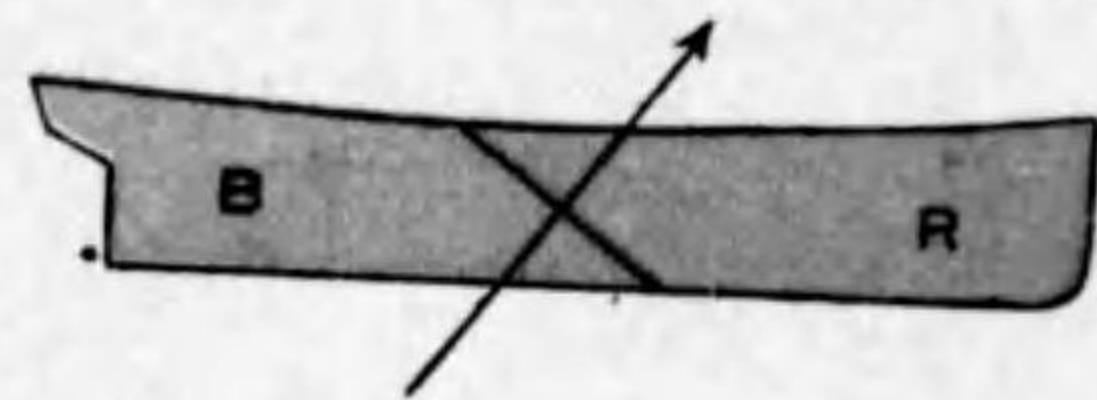

Fig. 7.

Fig. 7.

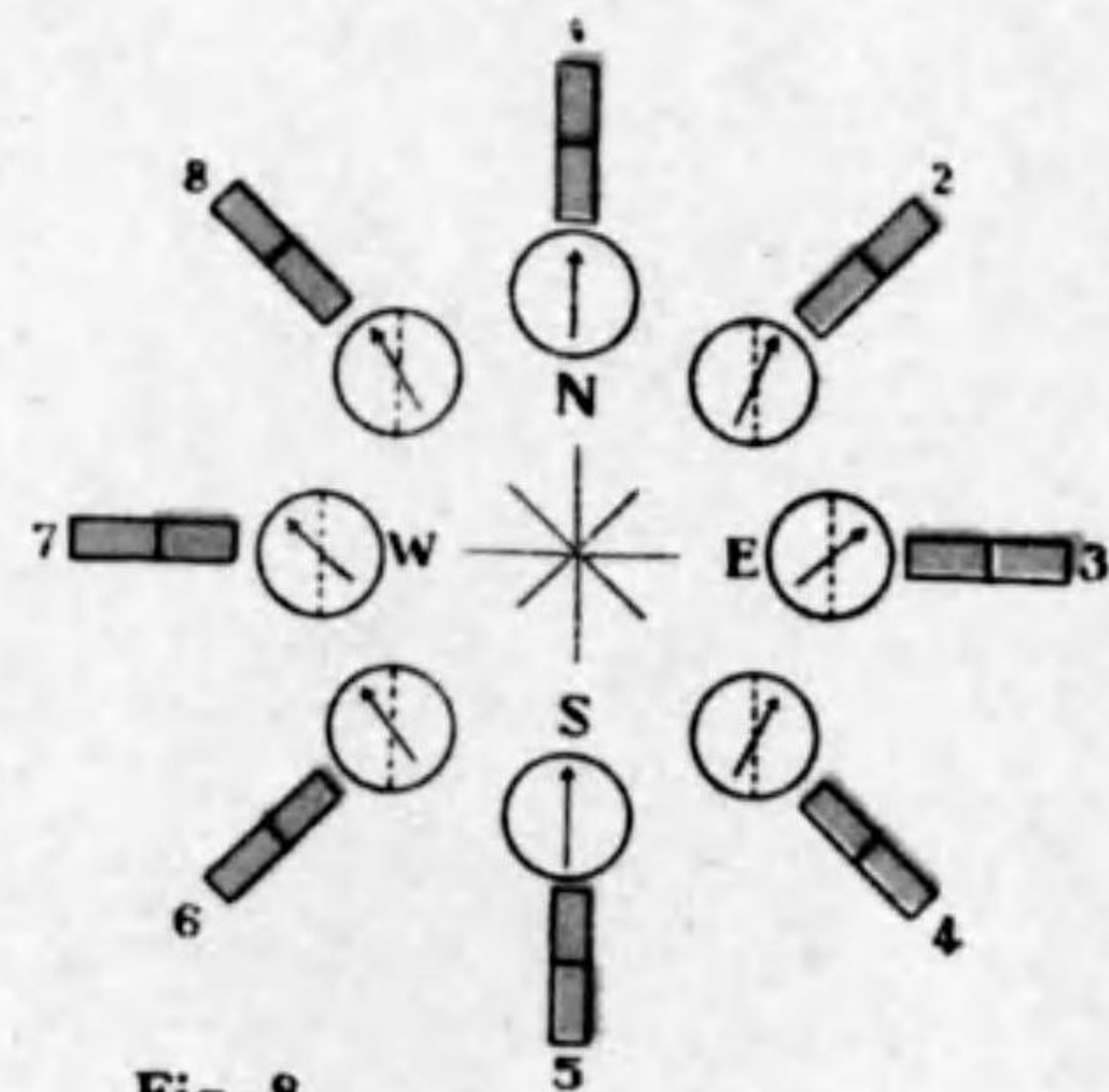

Fig. 8.

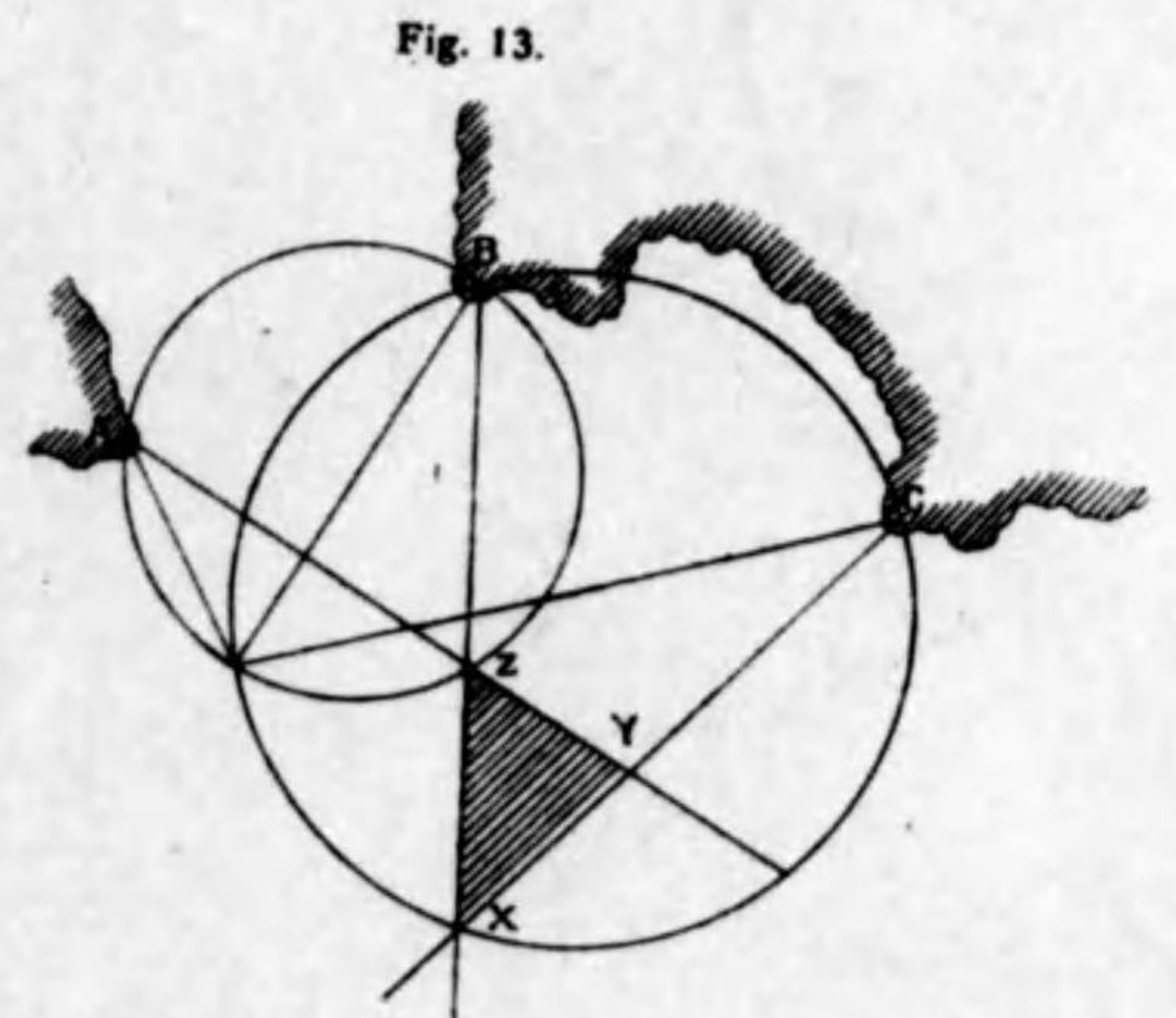
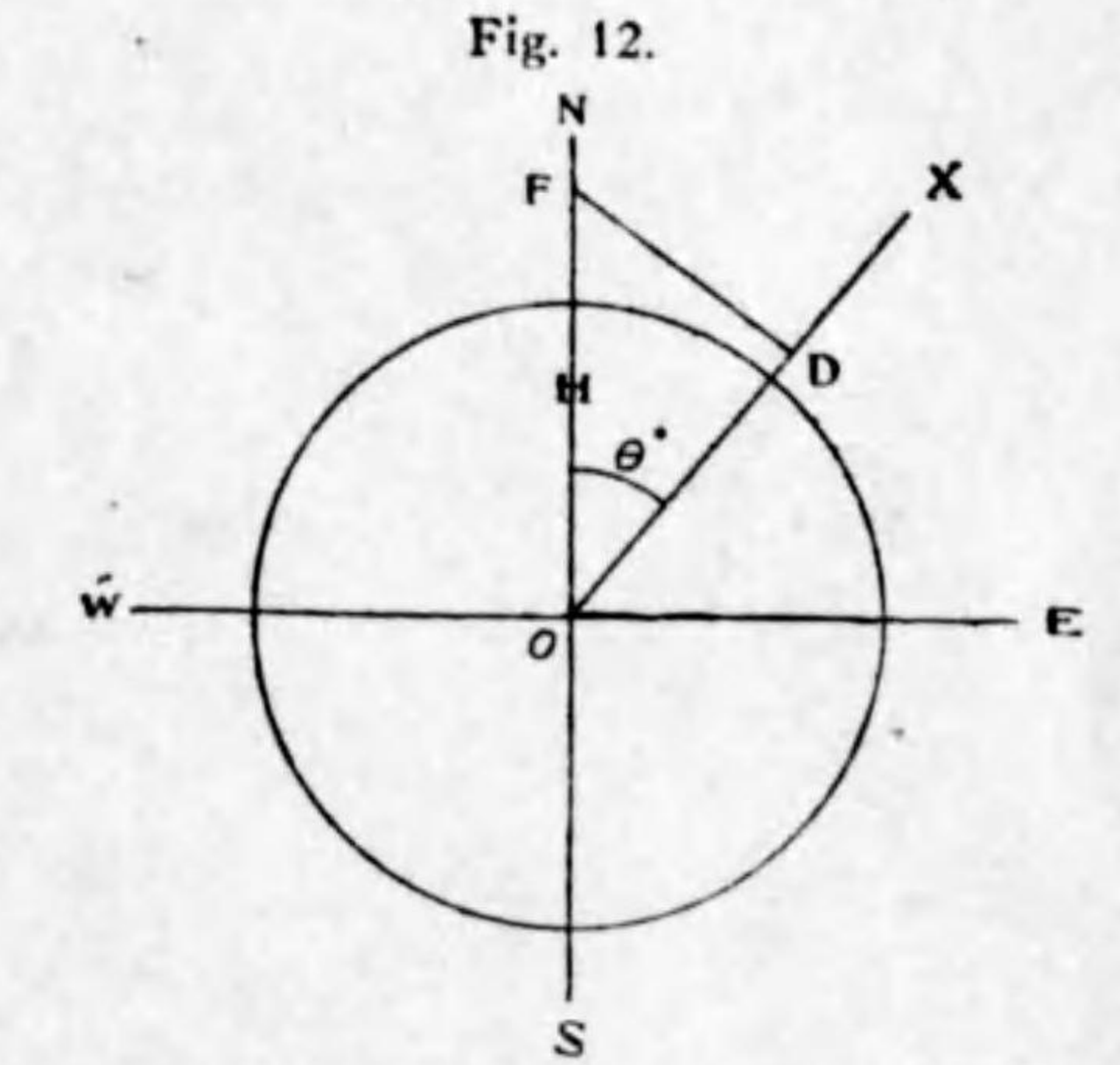
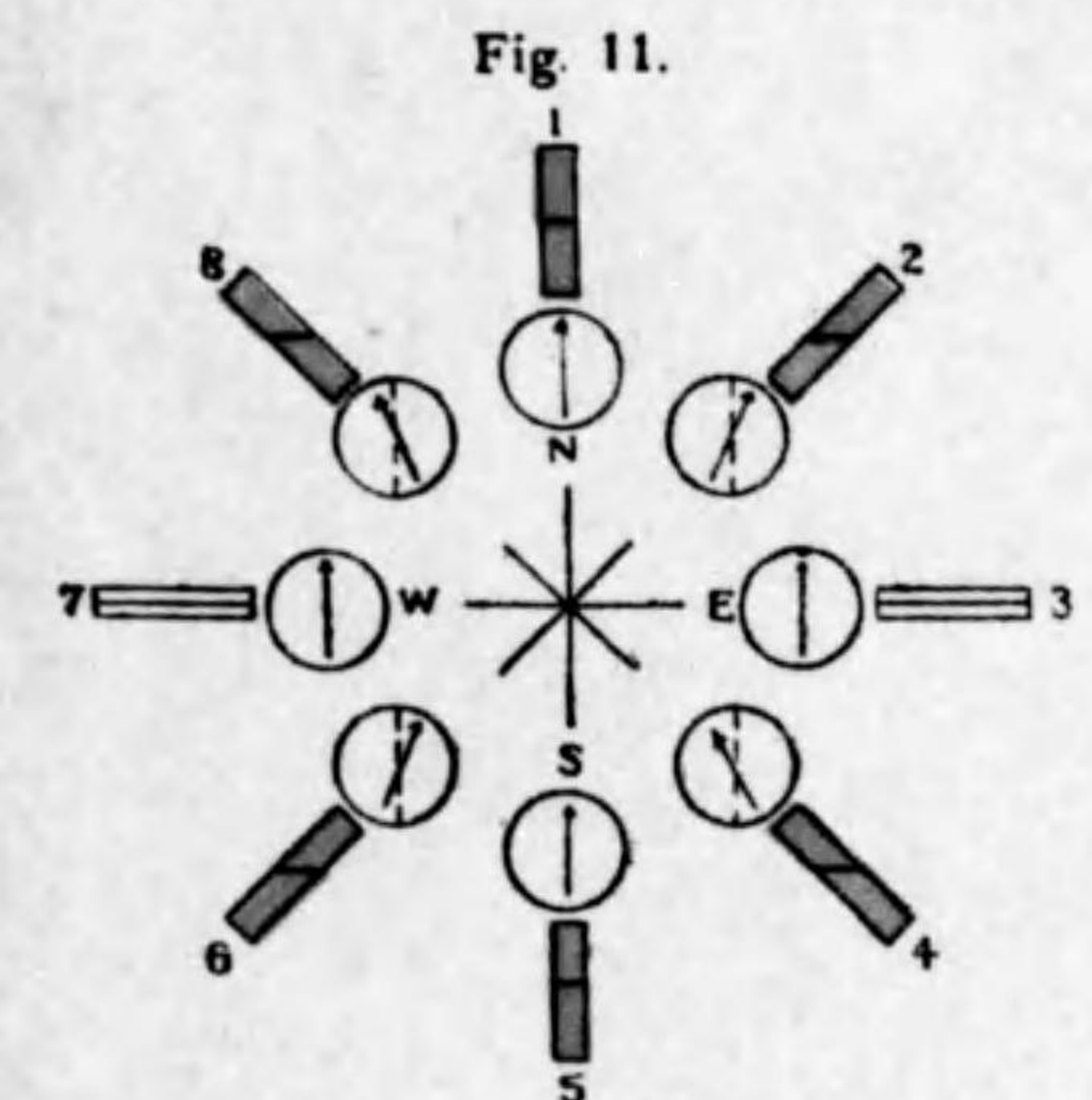
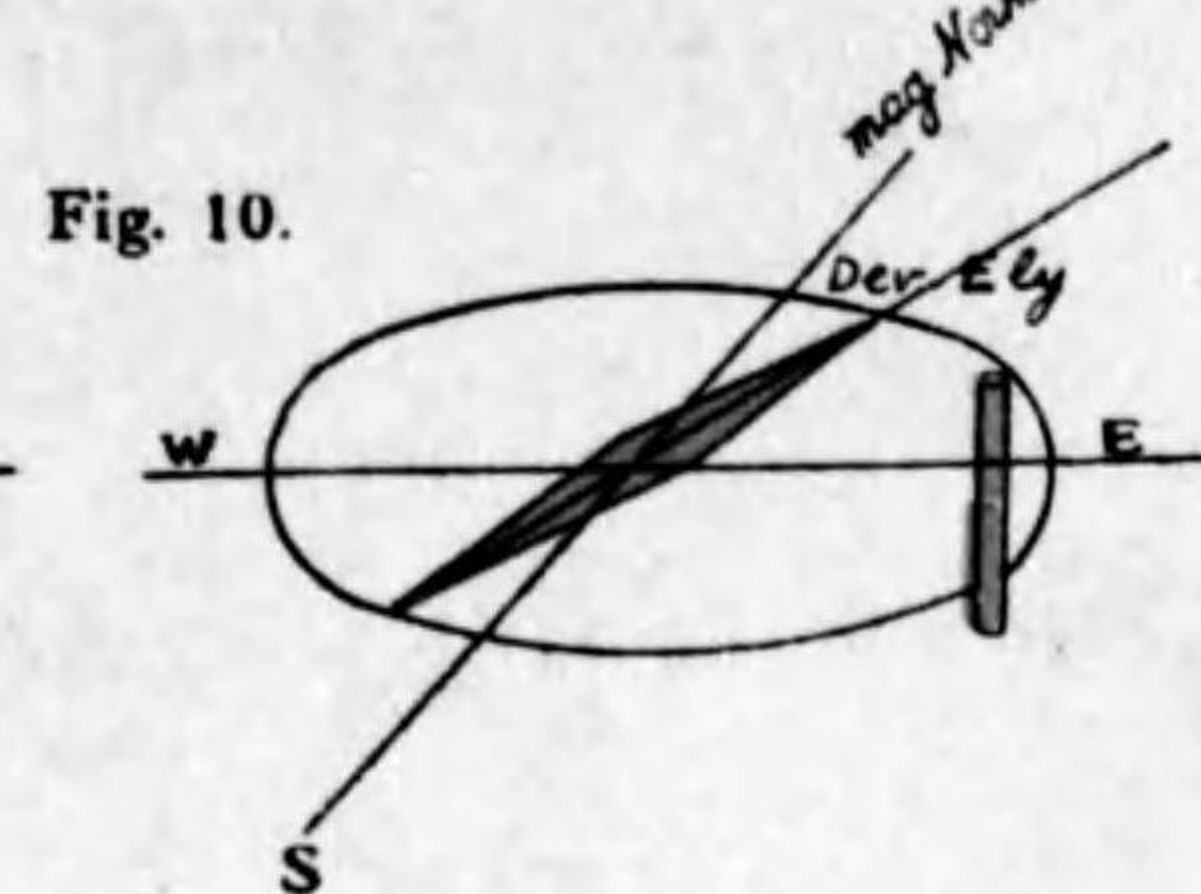
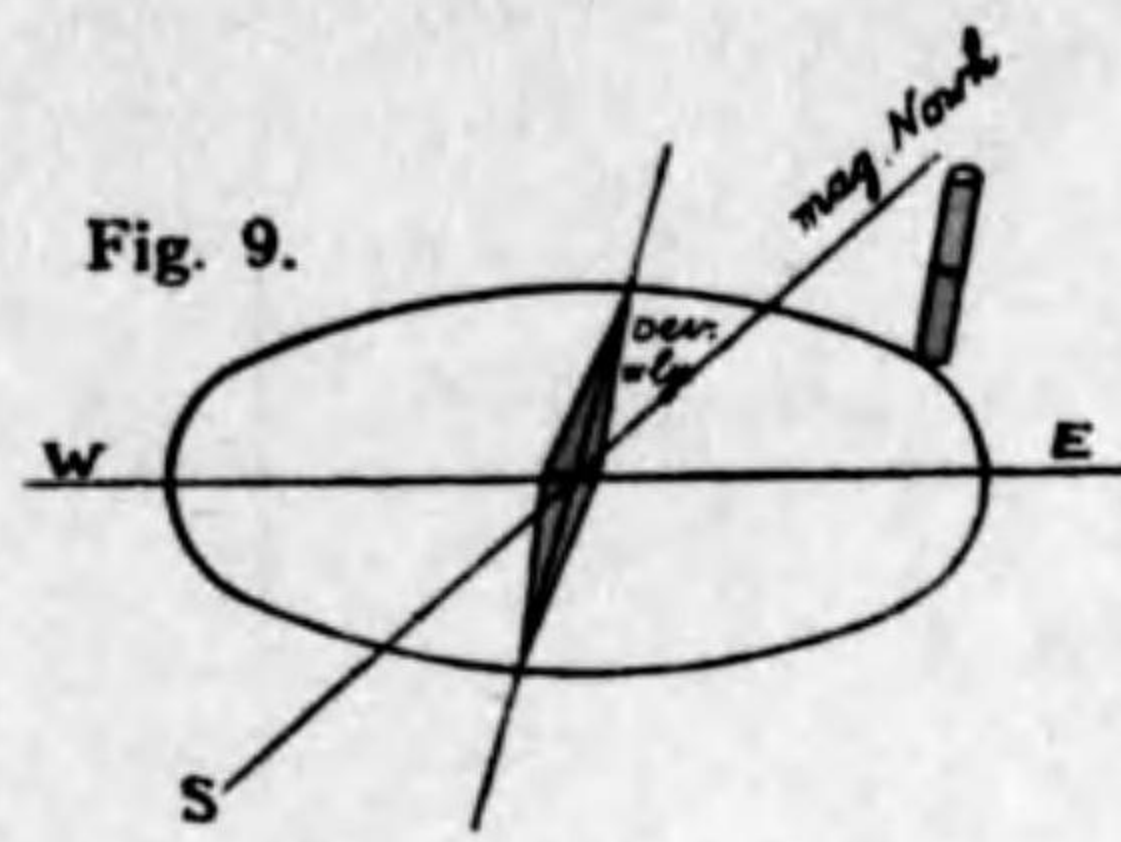
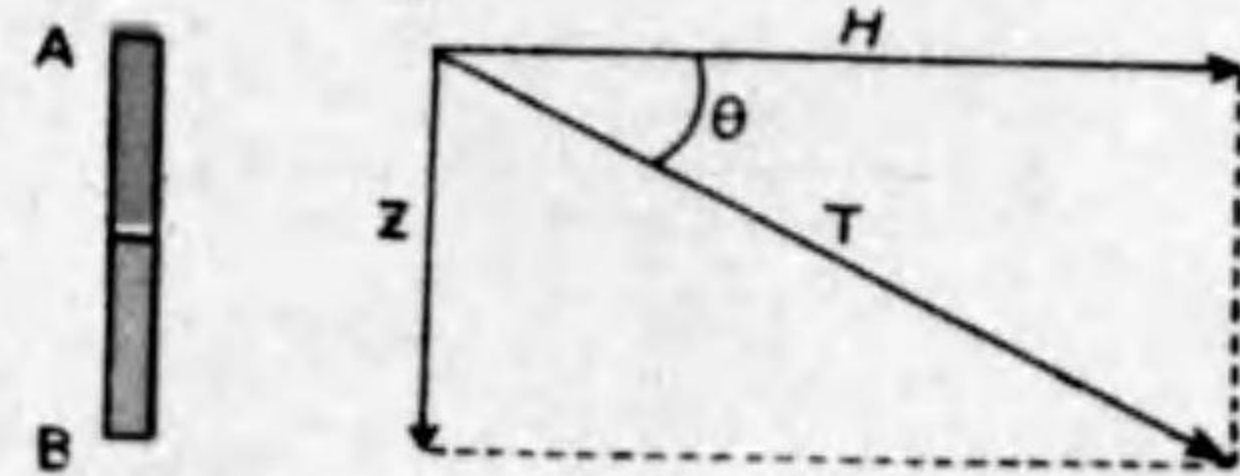

Fig. 14.-A.

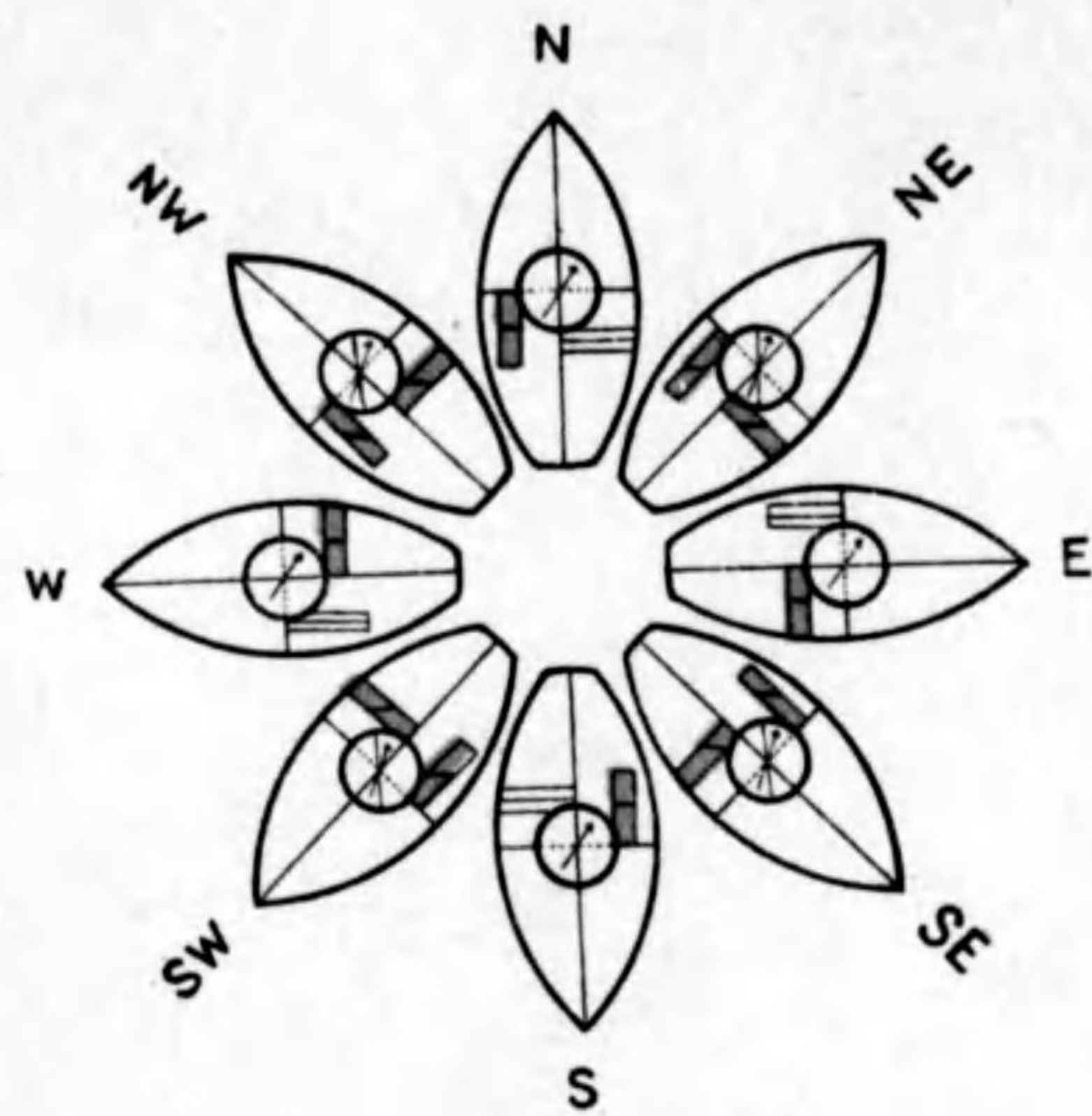

Fig. 14.-B.

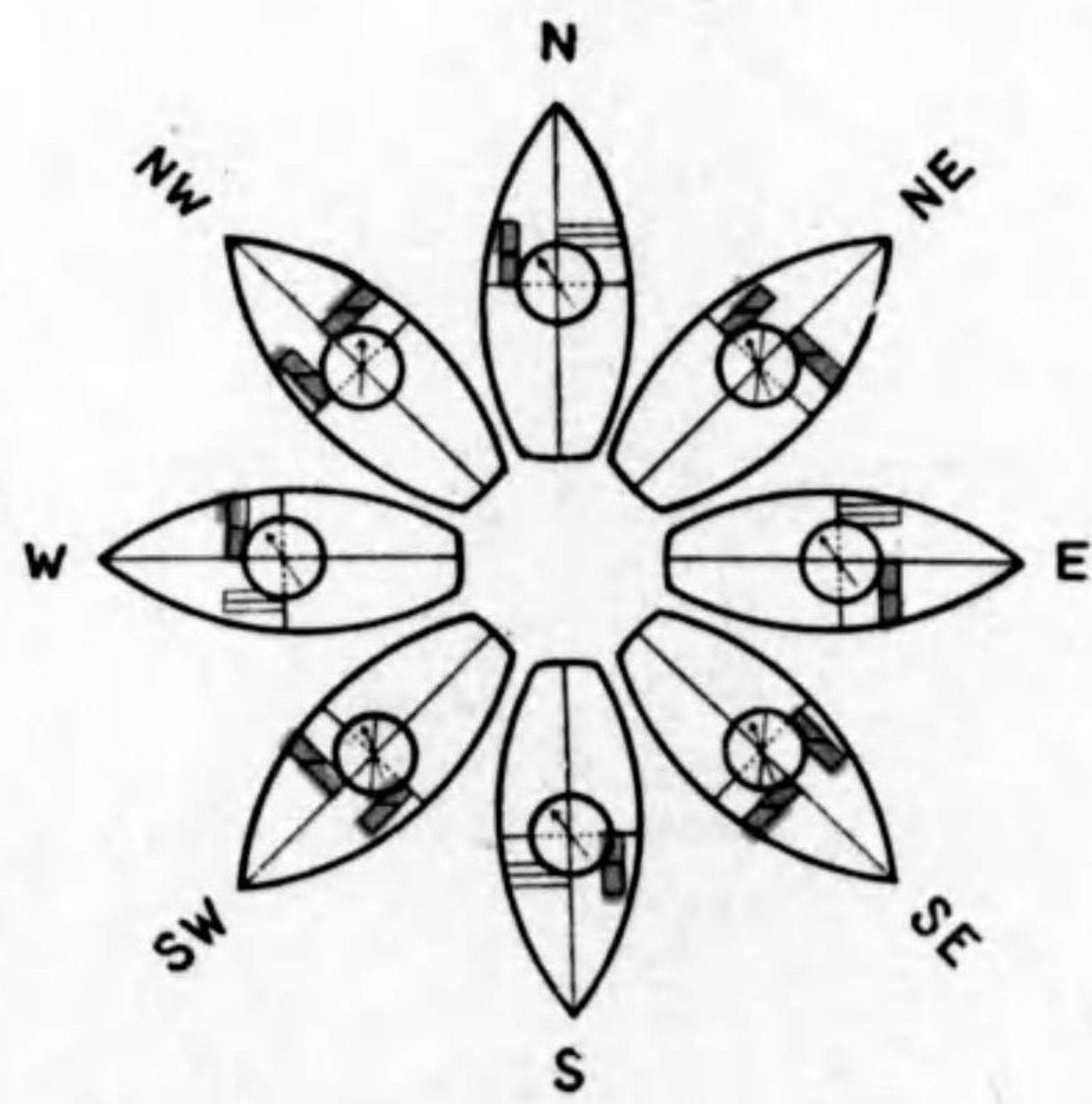

Fig. 15.-A.

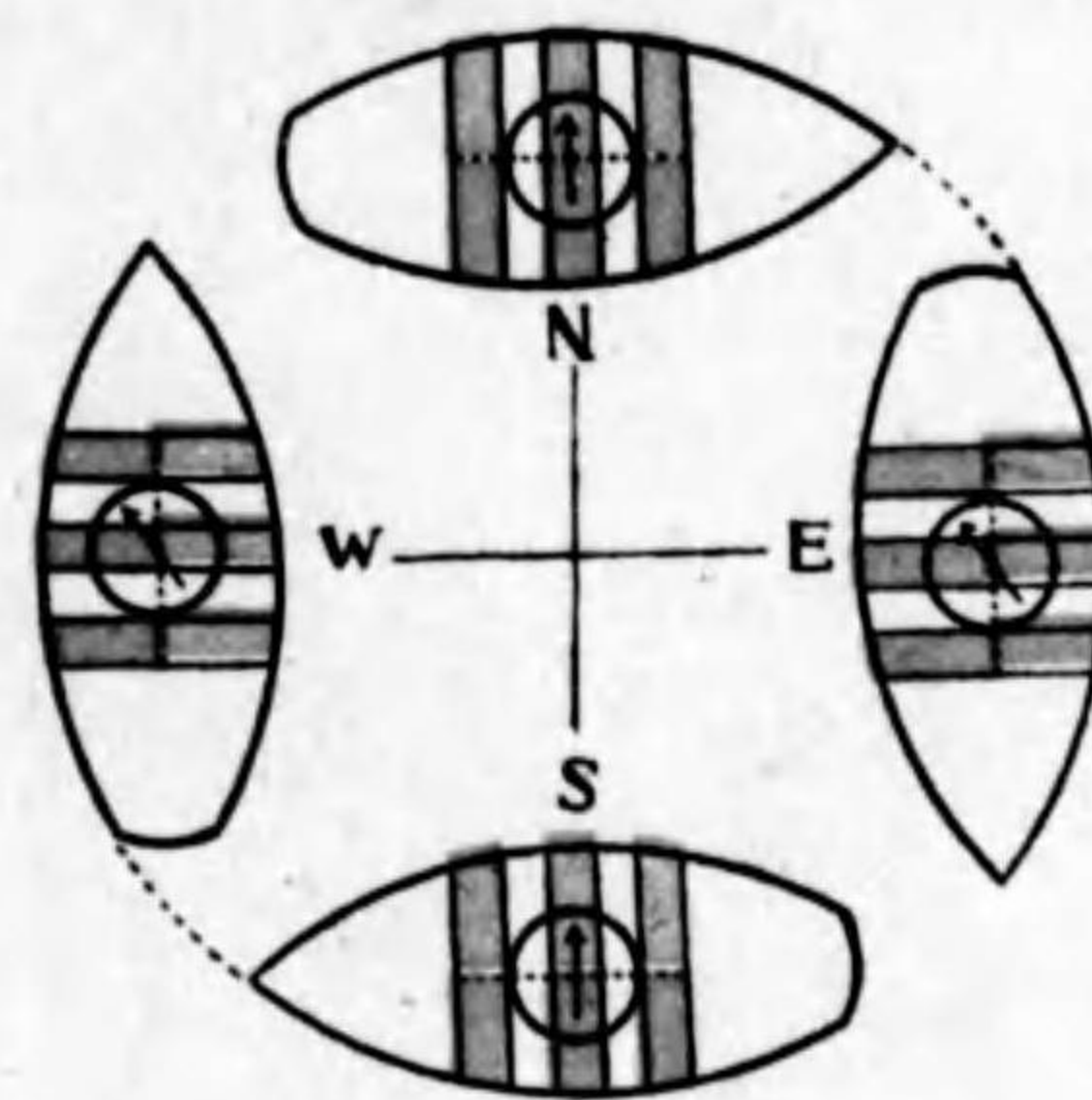

Fig. 15.-B.

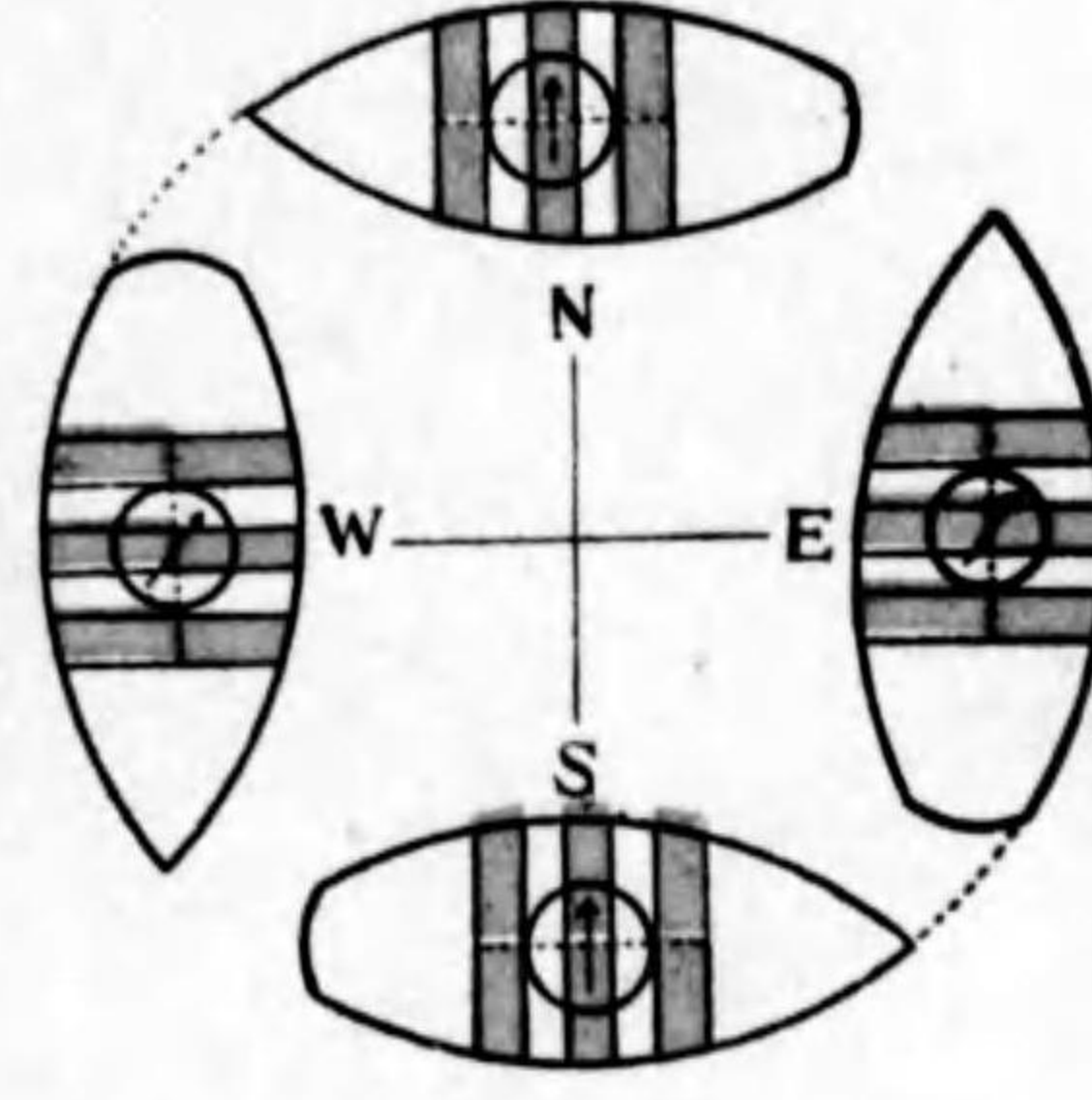

Fig. 16.-A.
+ B

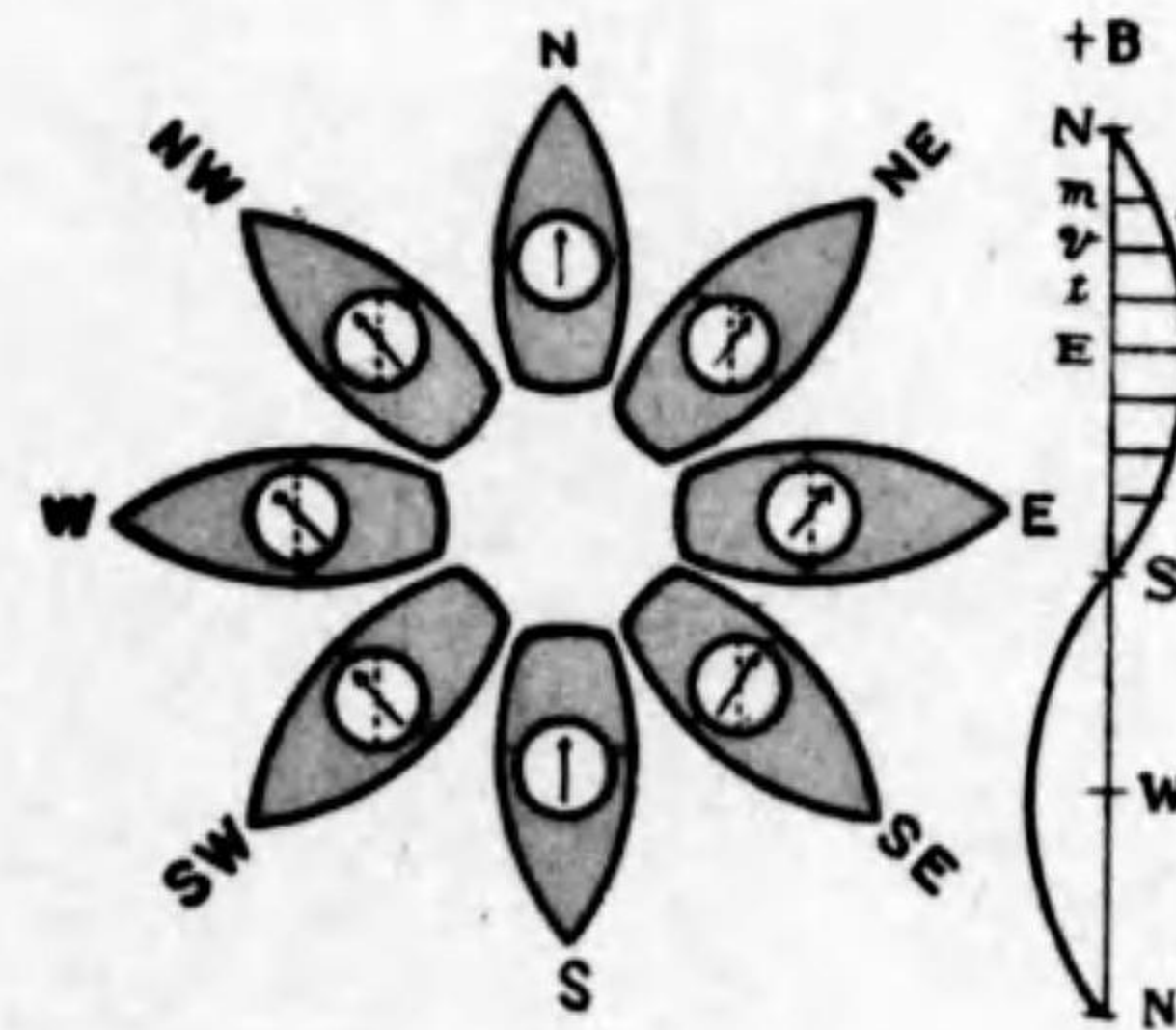

Fig. 16.-B.
- B

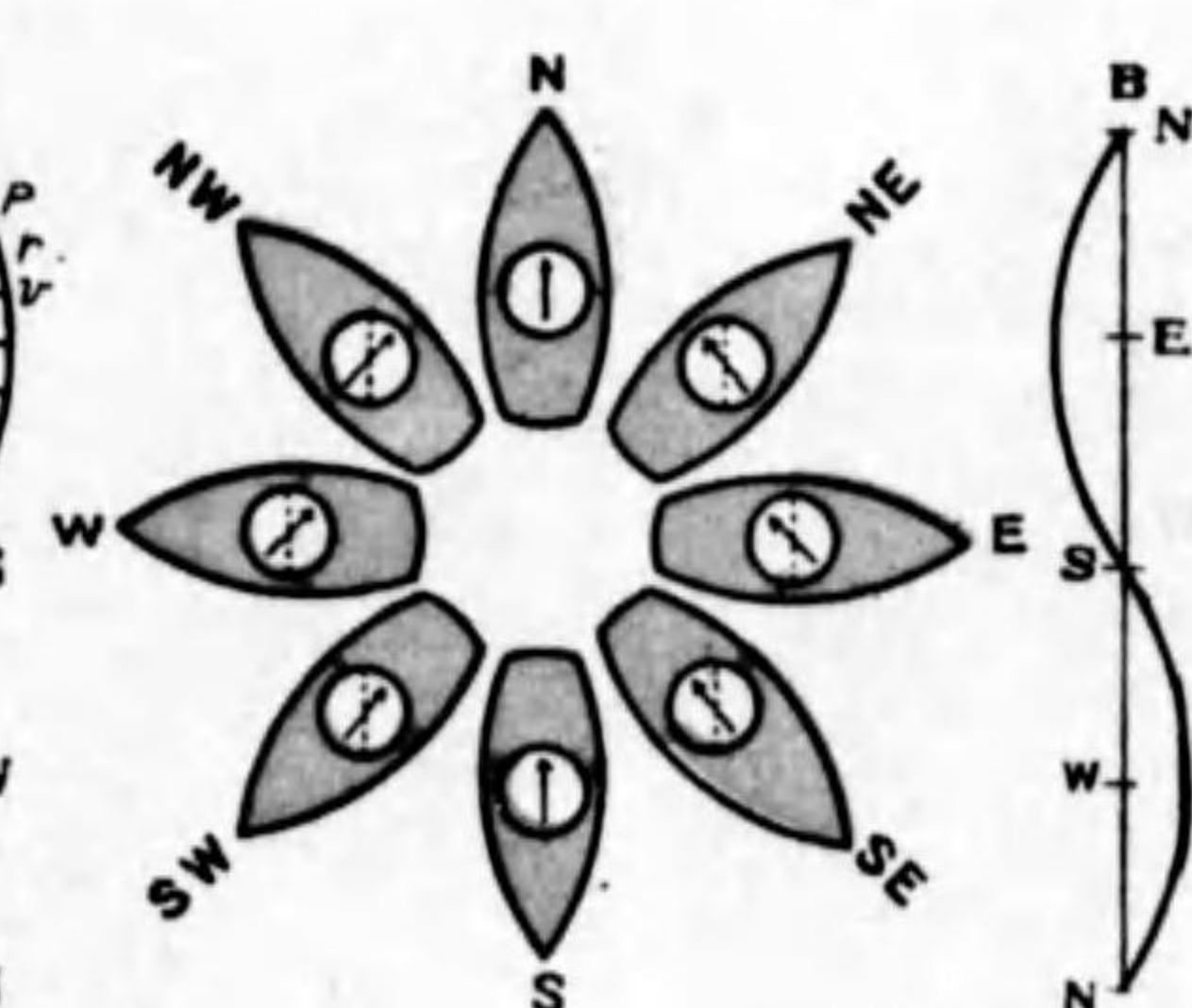

Fig. 17.-A.

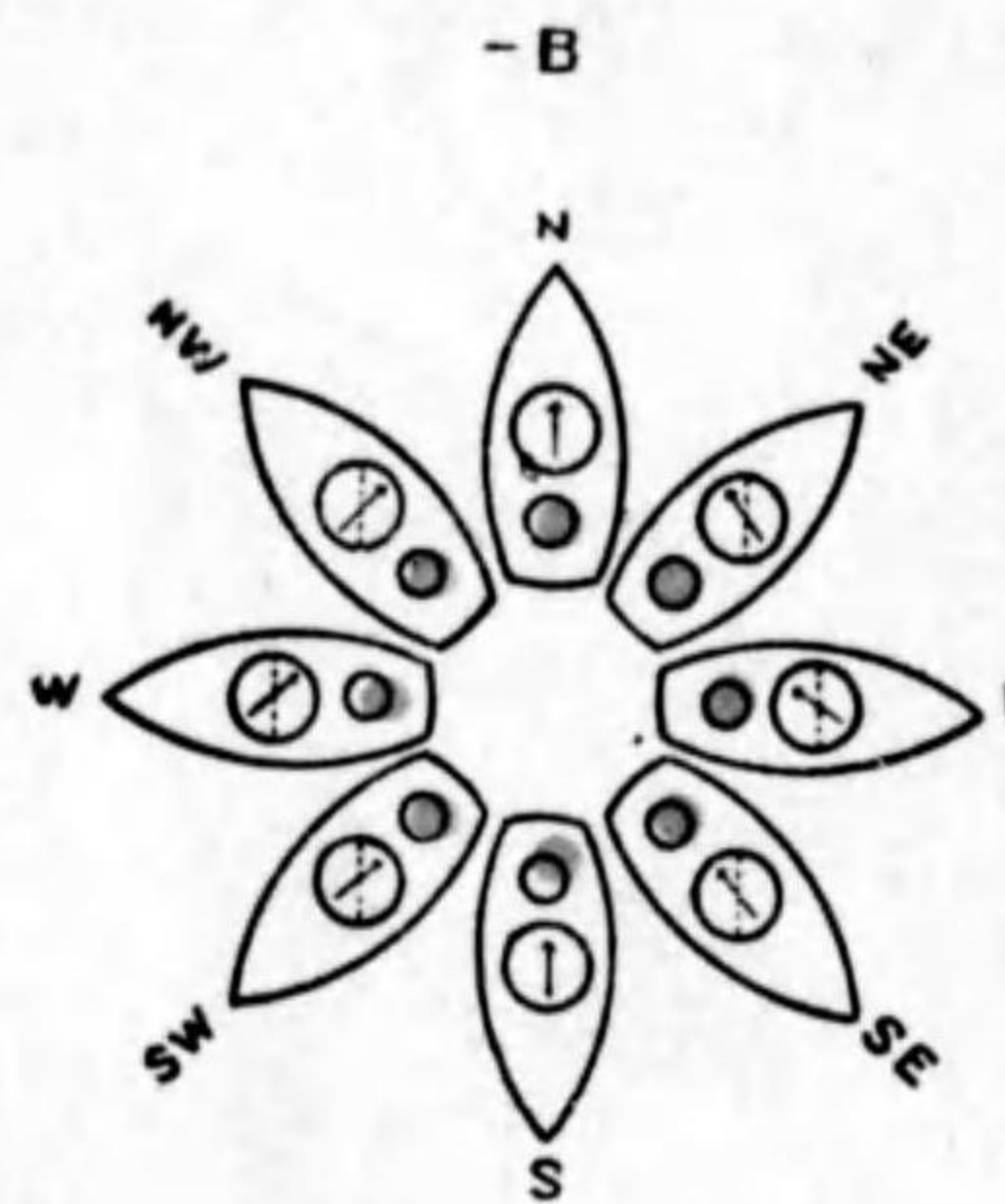

Fig. 17.-B.

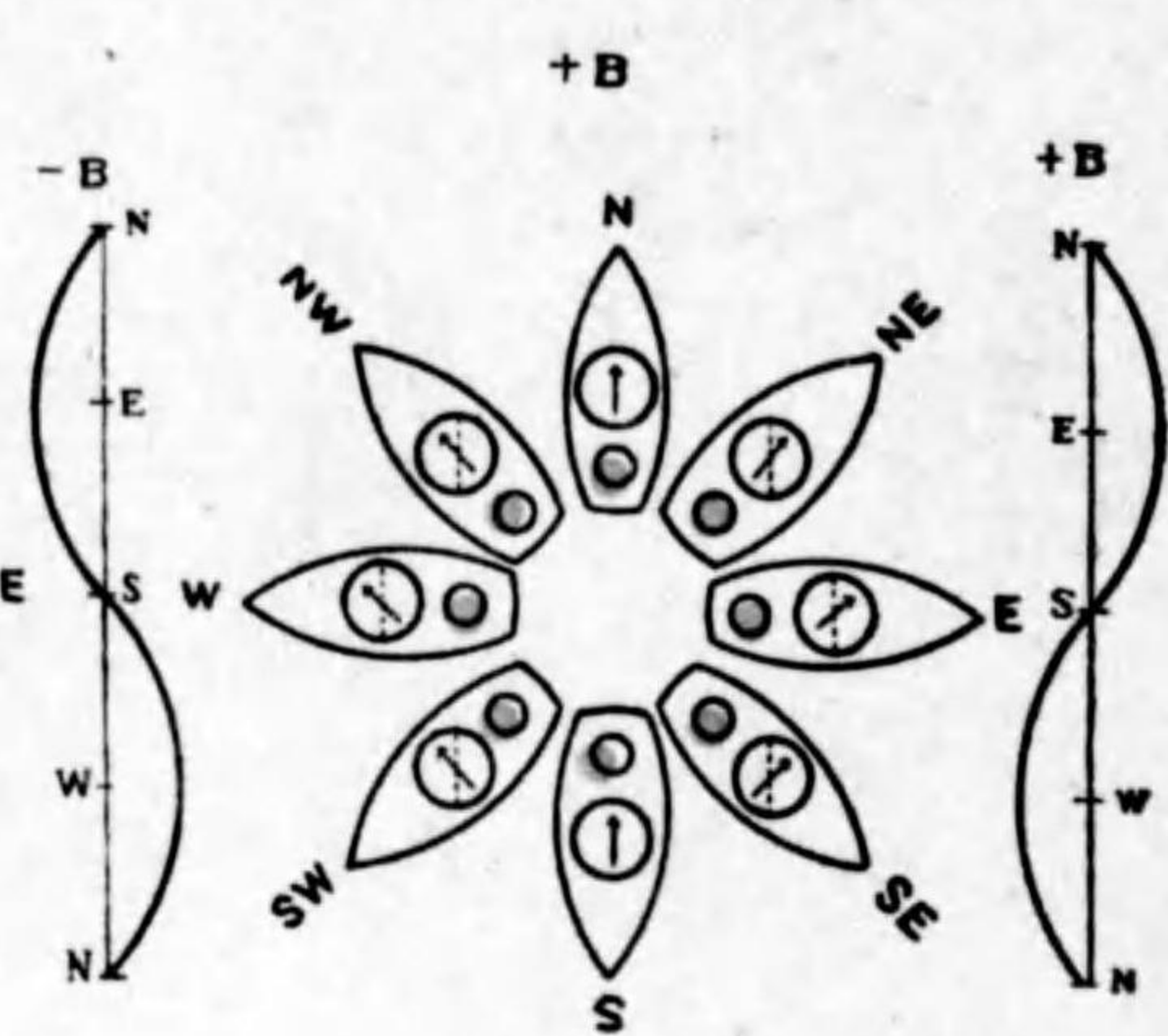

Fig. 18.-A.

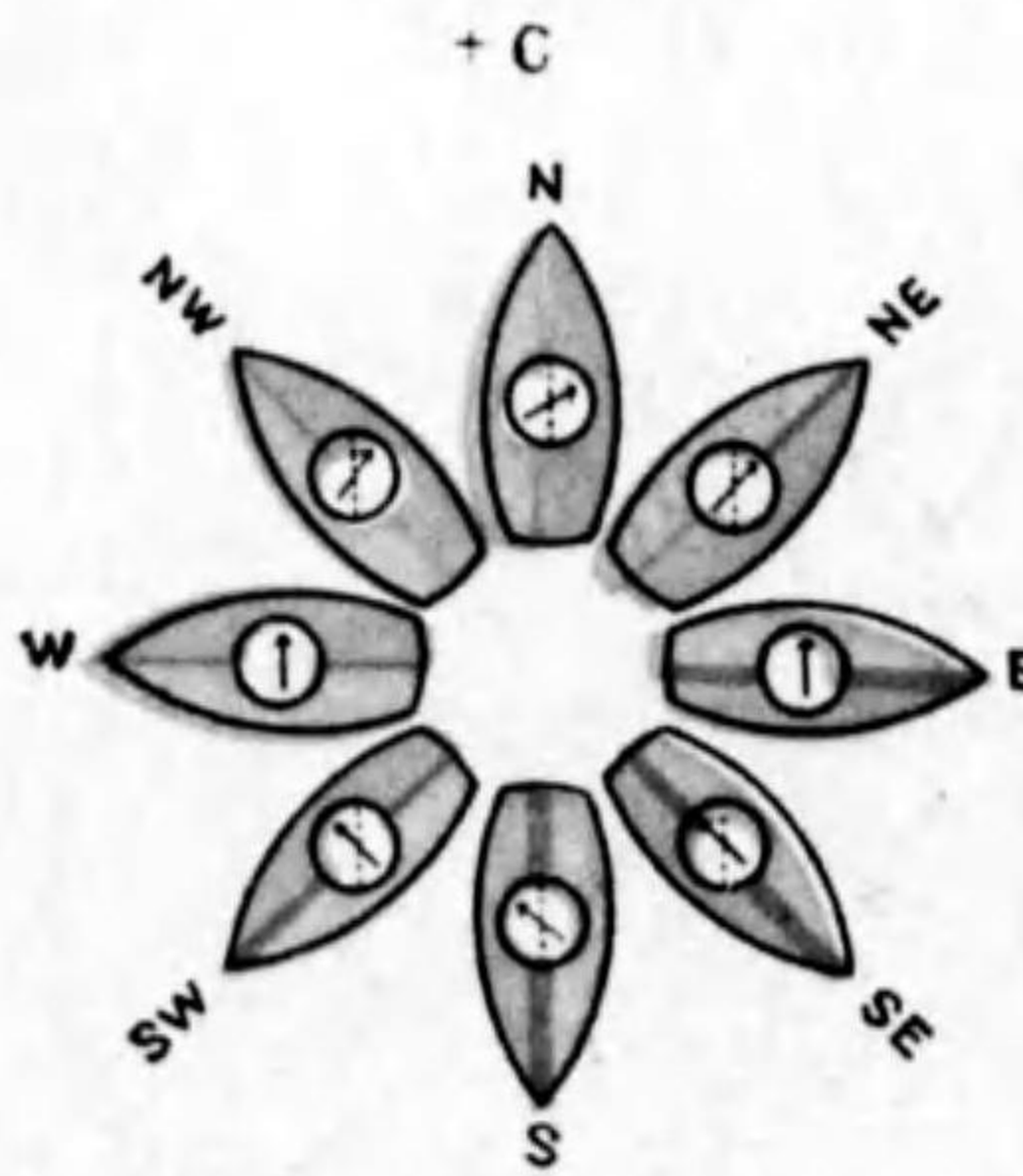

Fig. 18.-B.

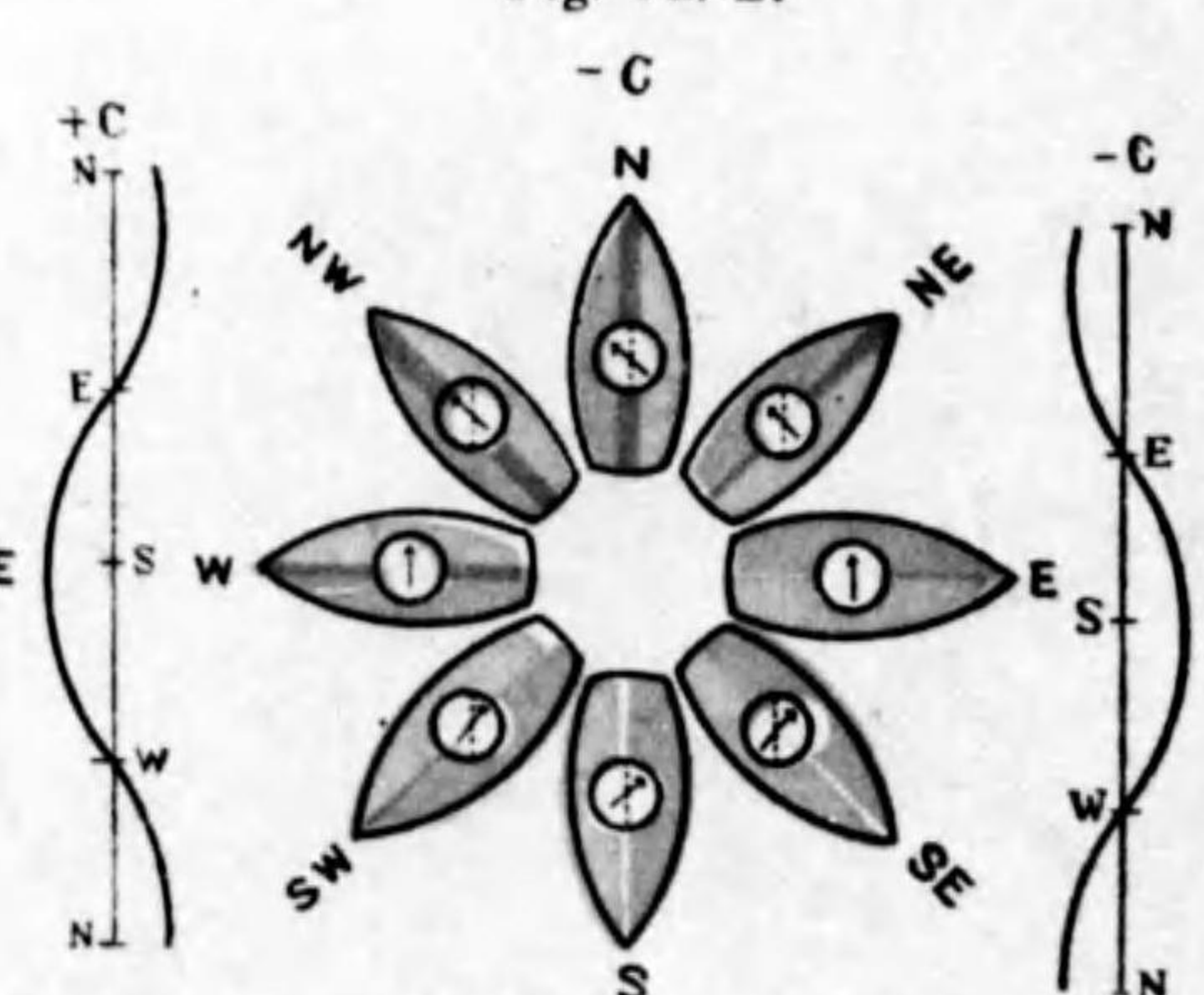

Fig. 19.-A.

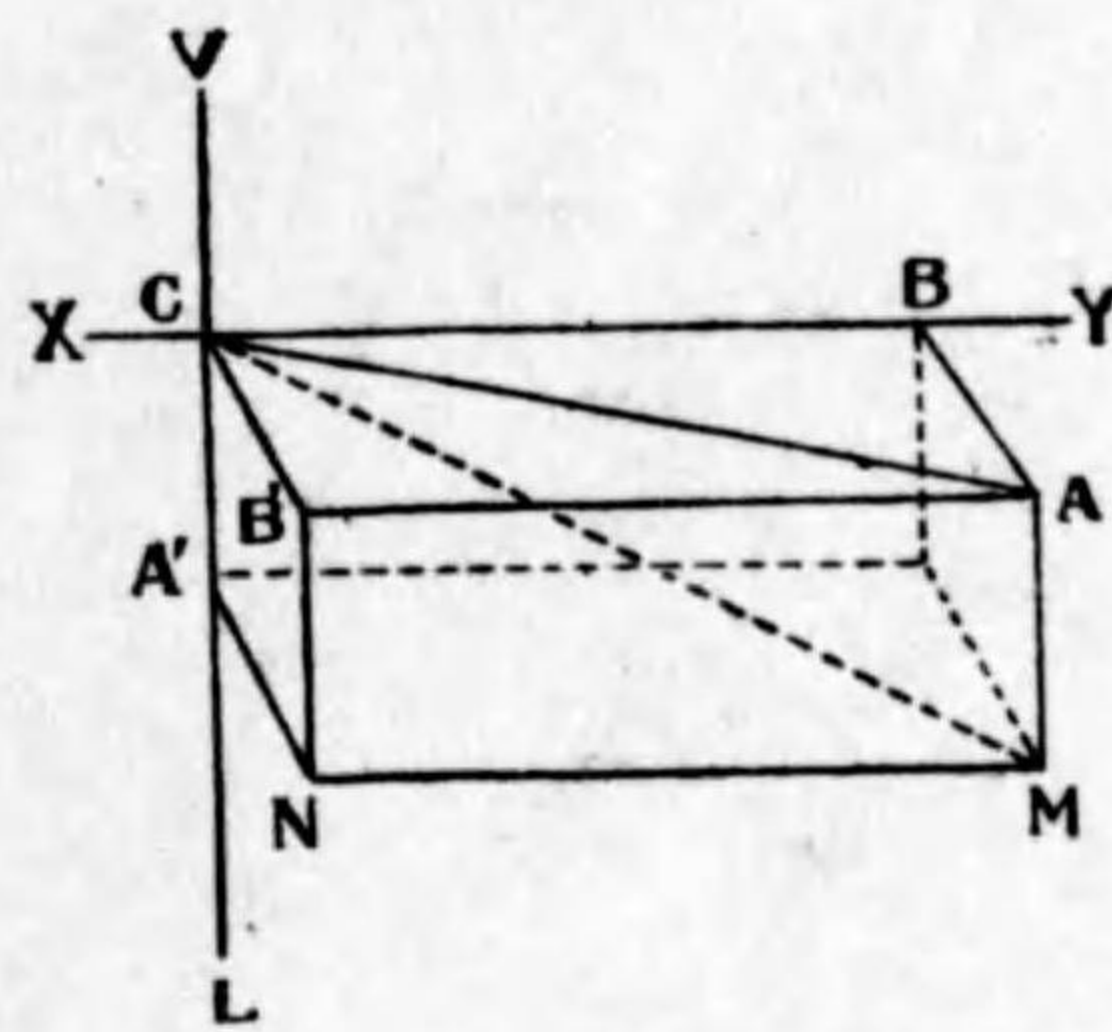

Fig. 19.-B.

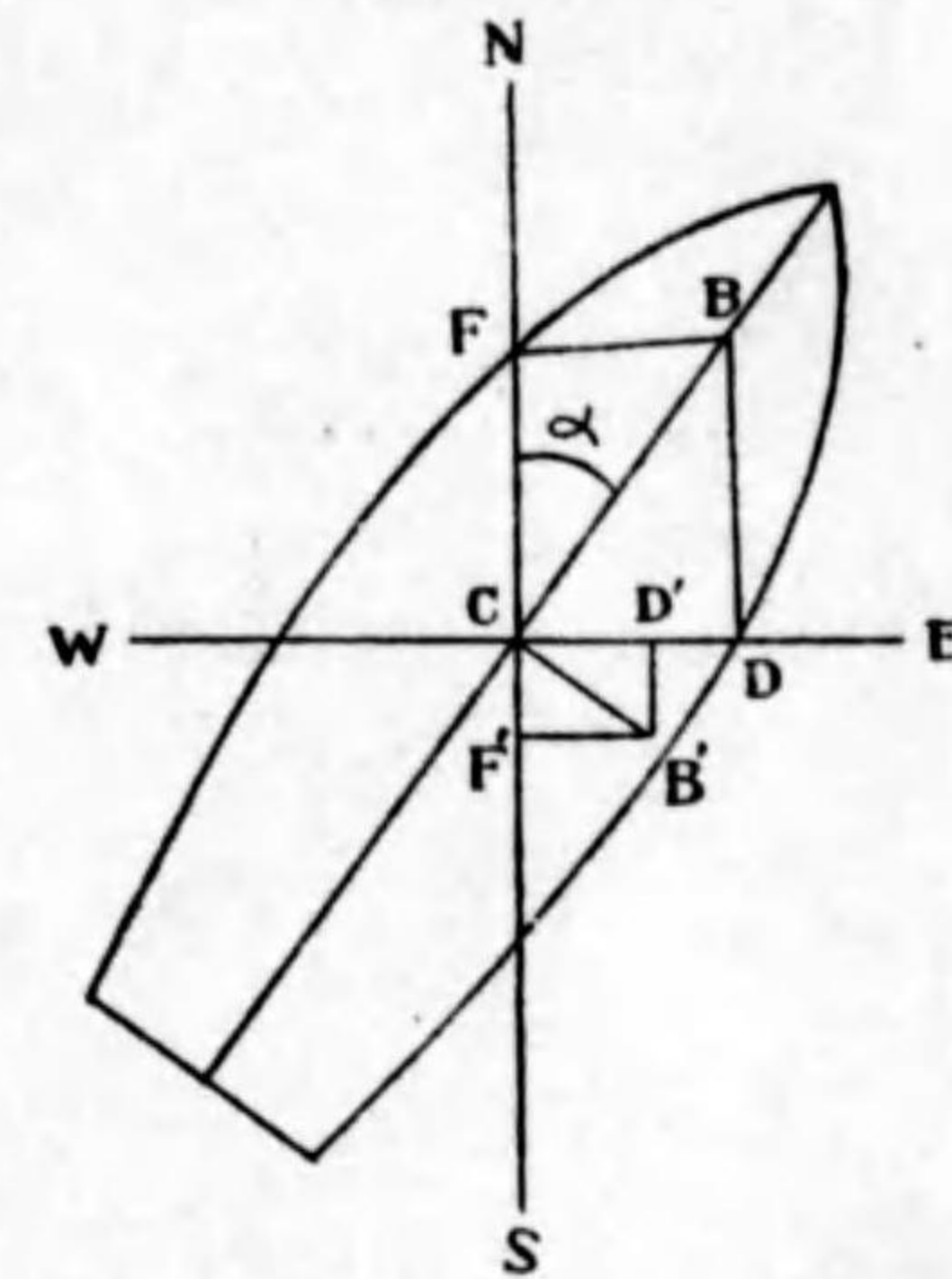
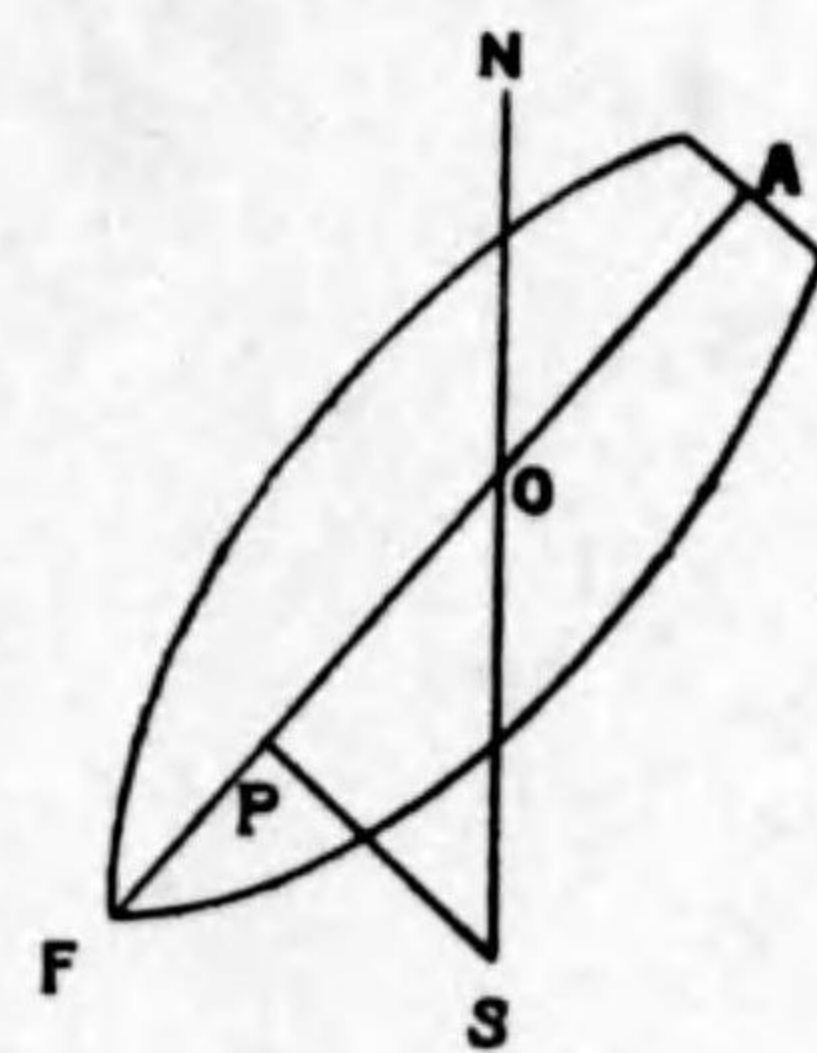

Fig. 20.



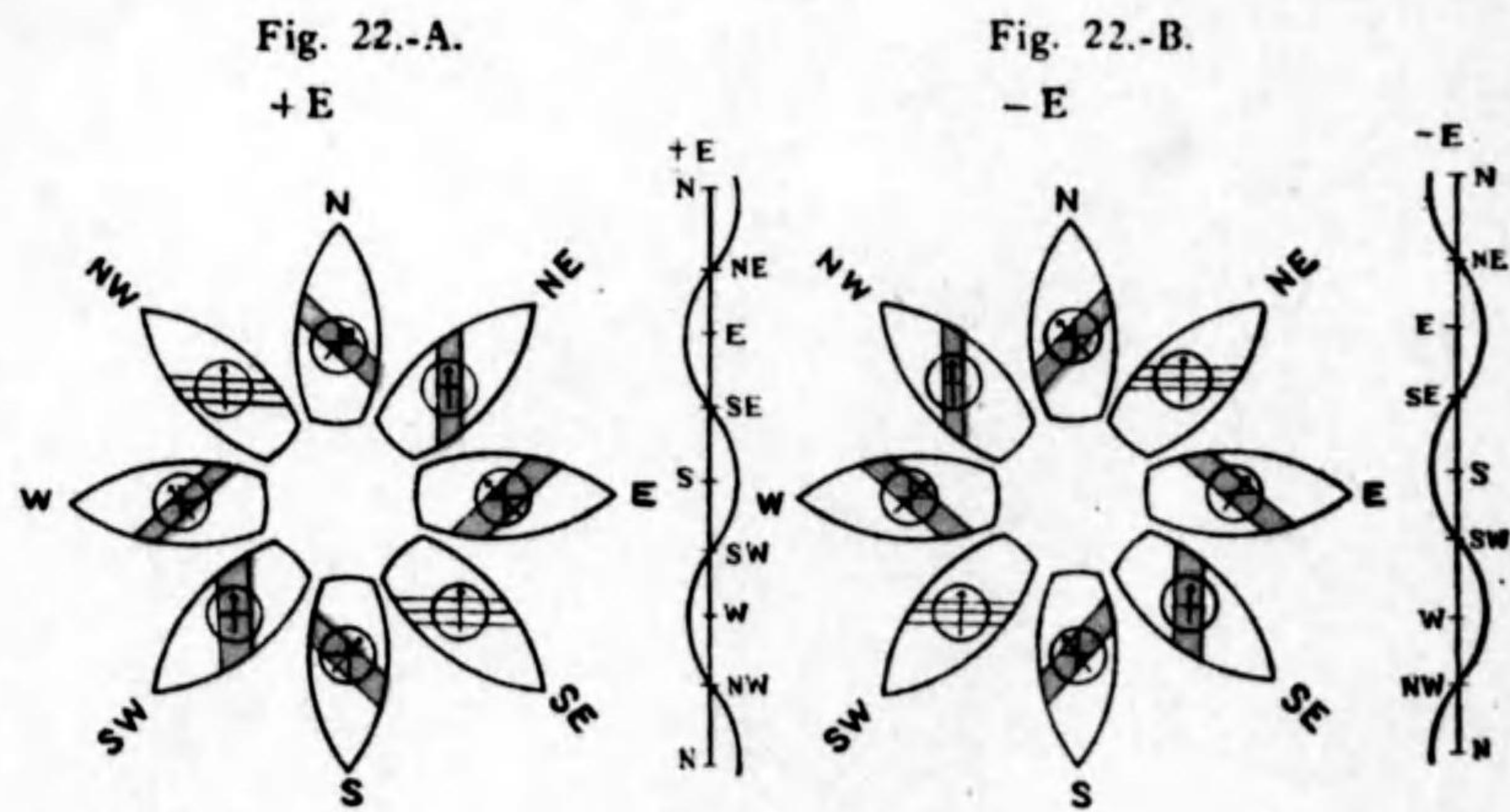
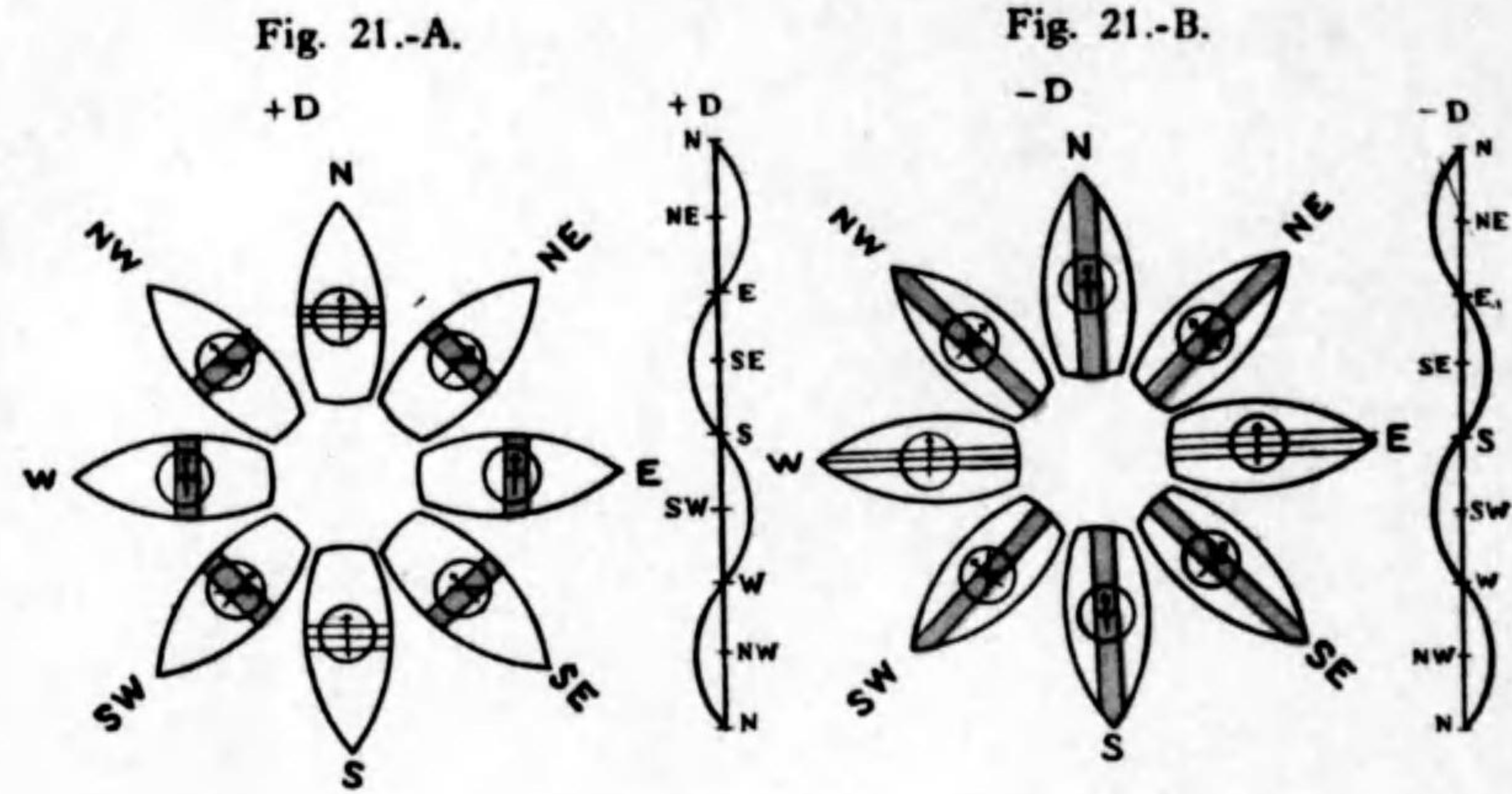

Fig. 23.

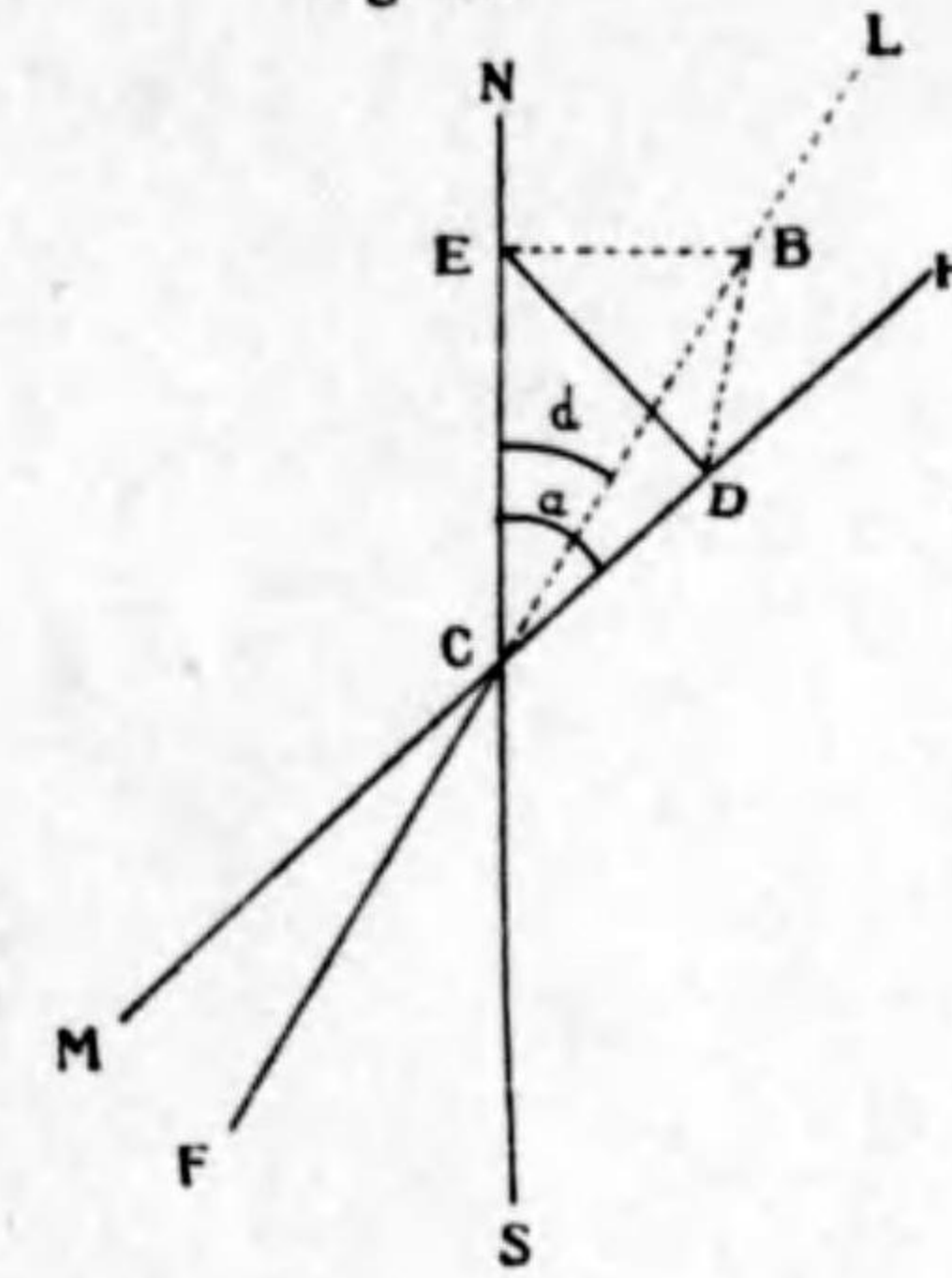

Fig. 24.

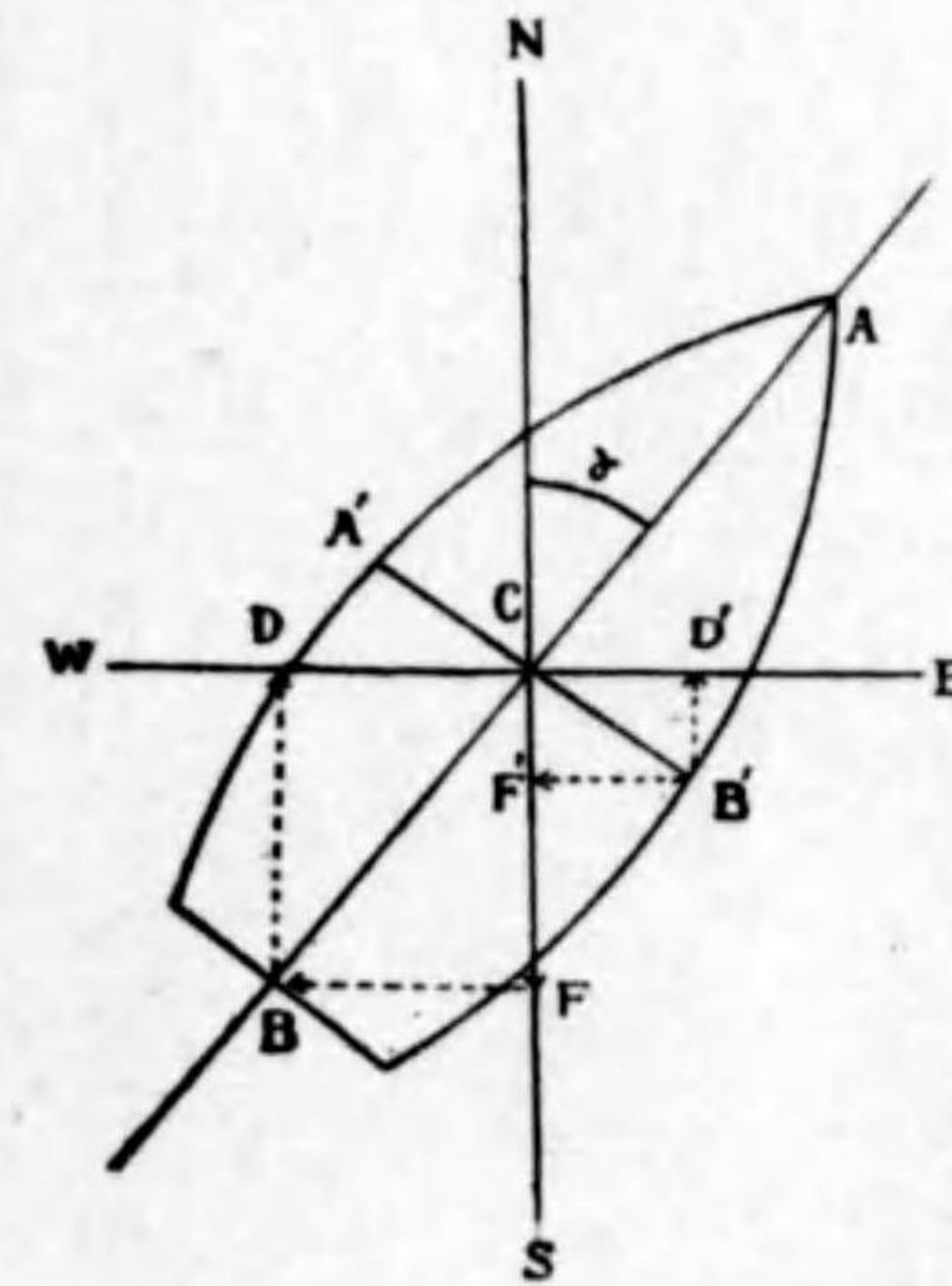
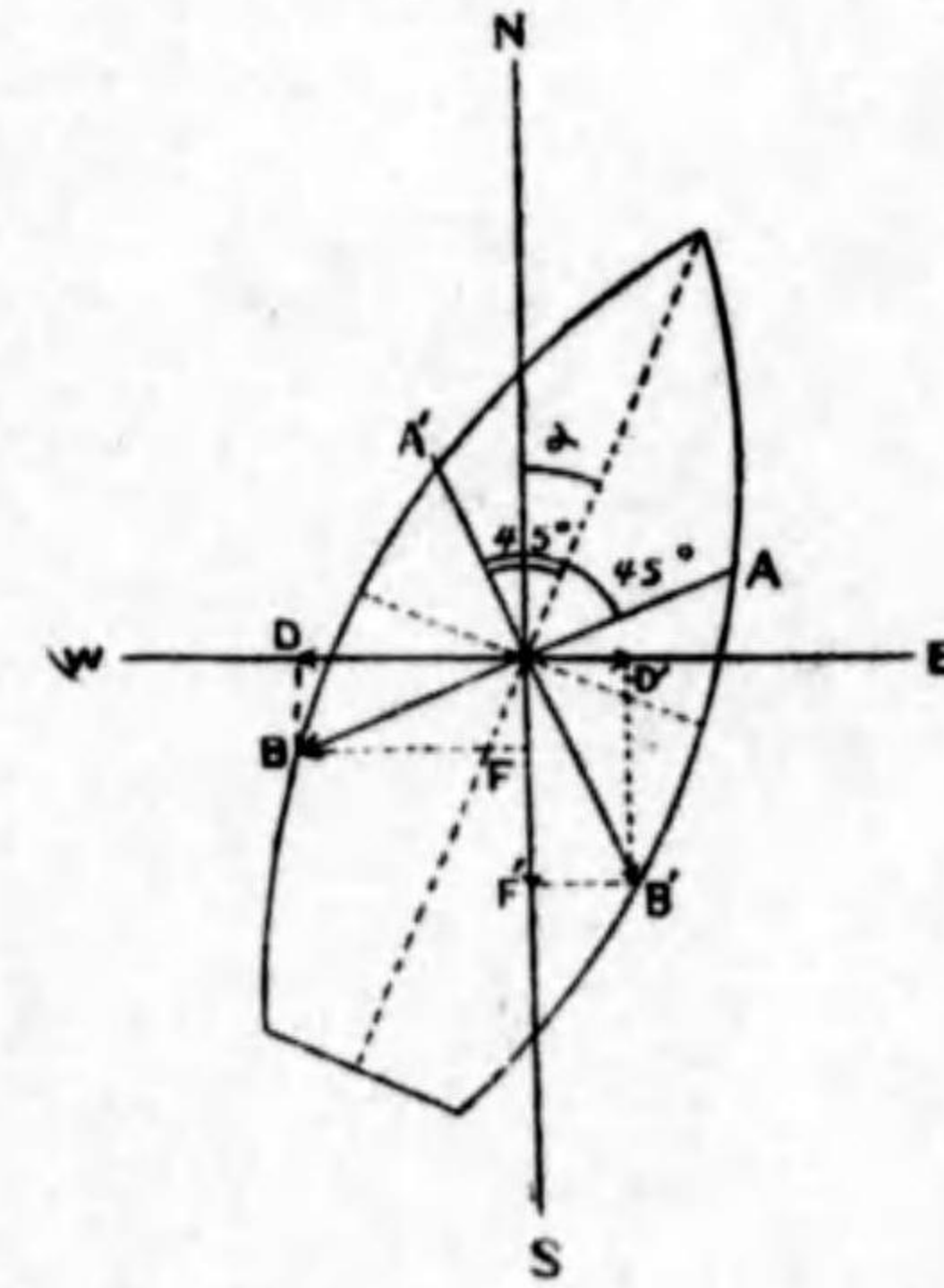

Fig. 25.



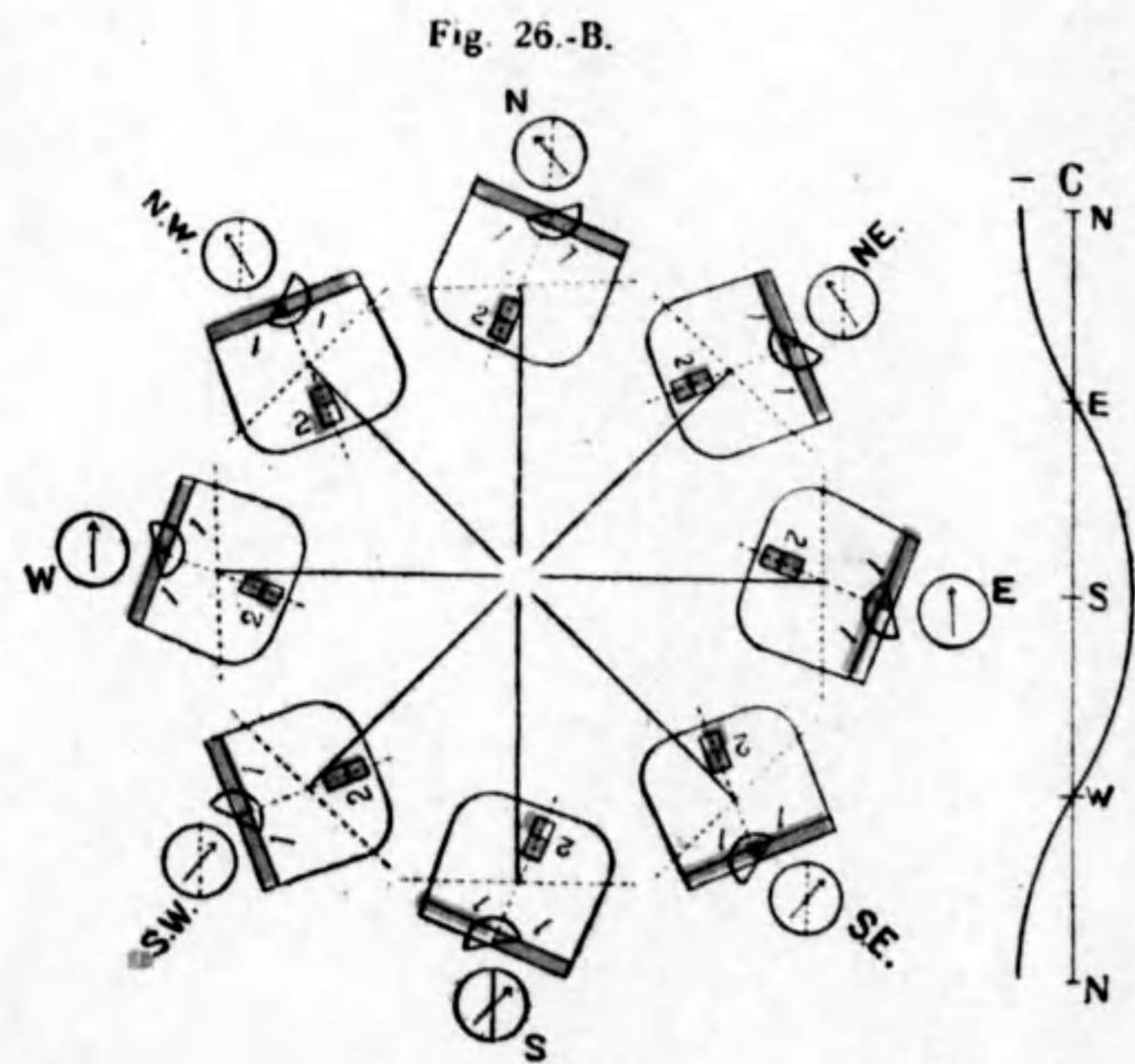
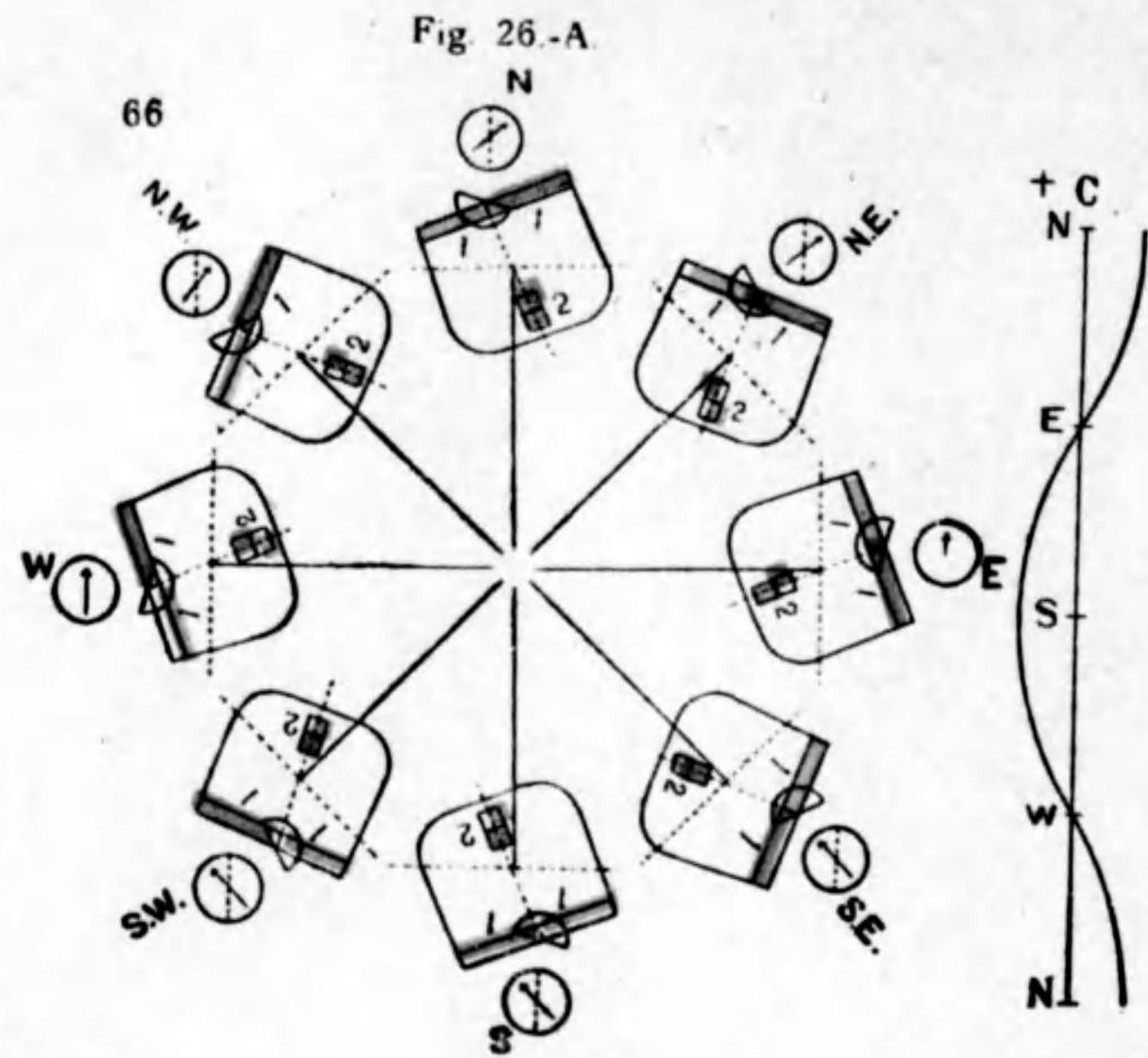

Fig 27



Fig. 28.

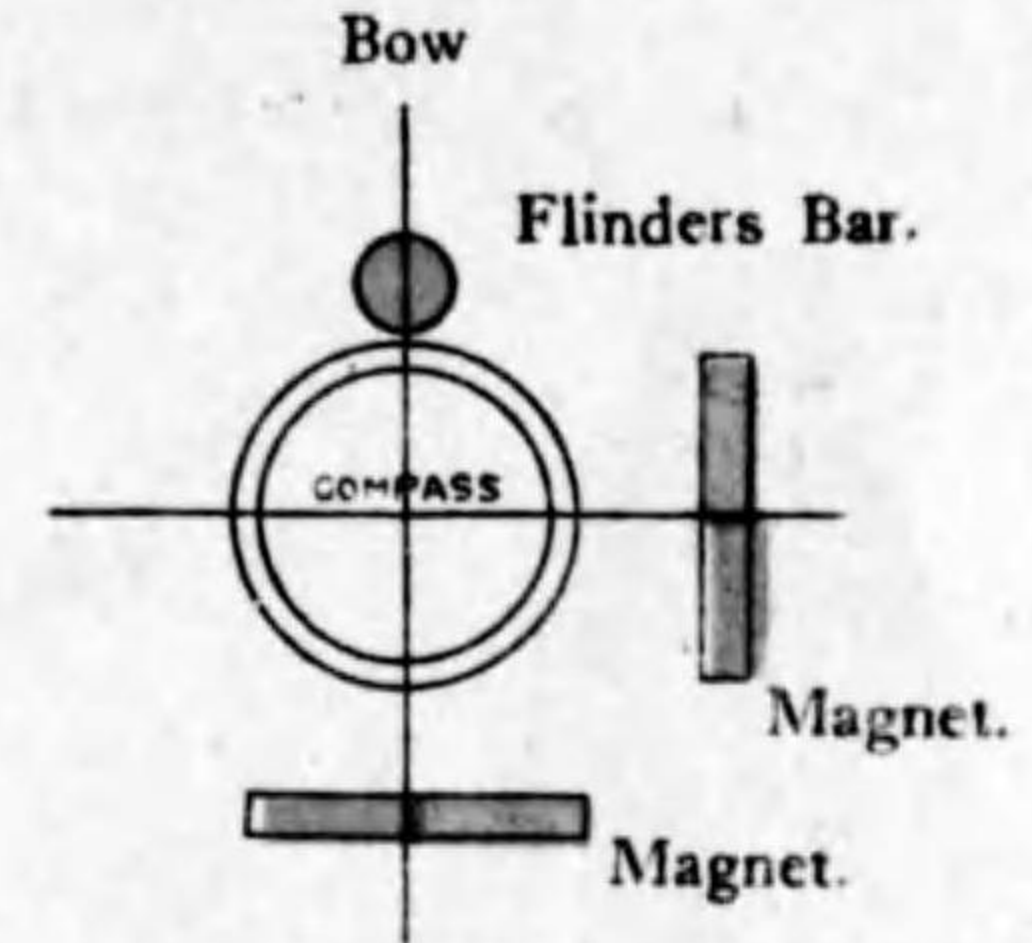

Fig. 29.

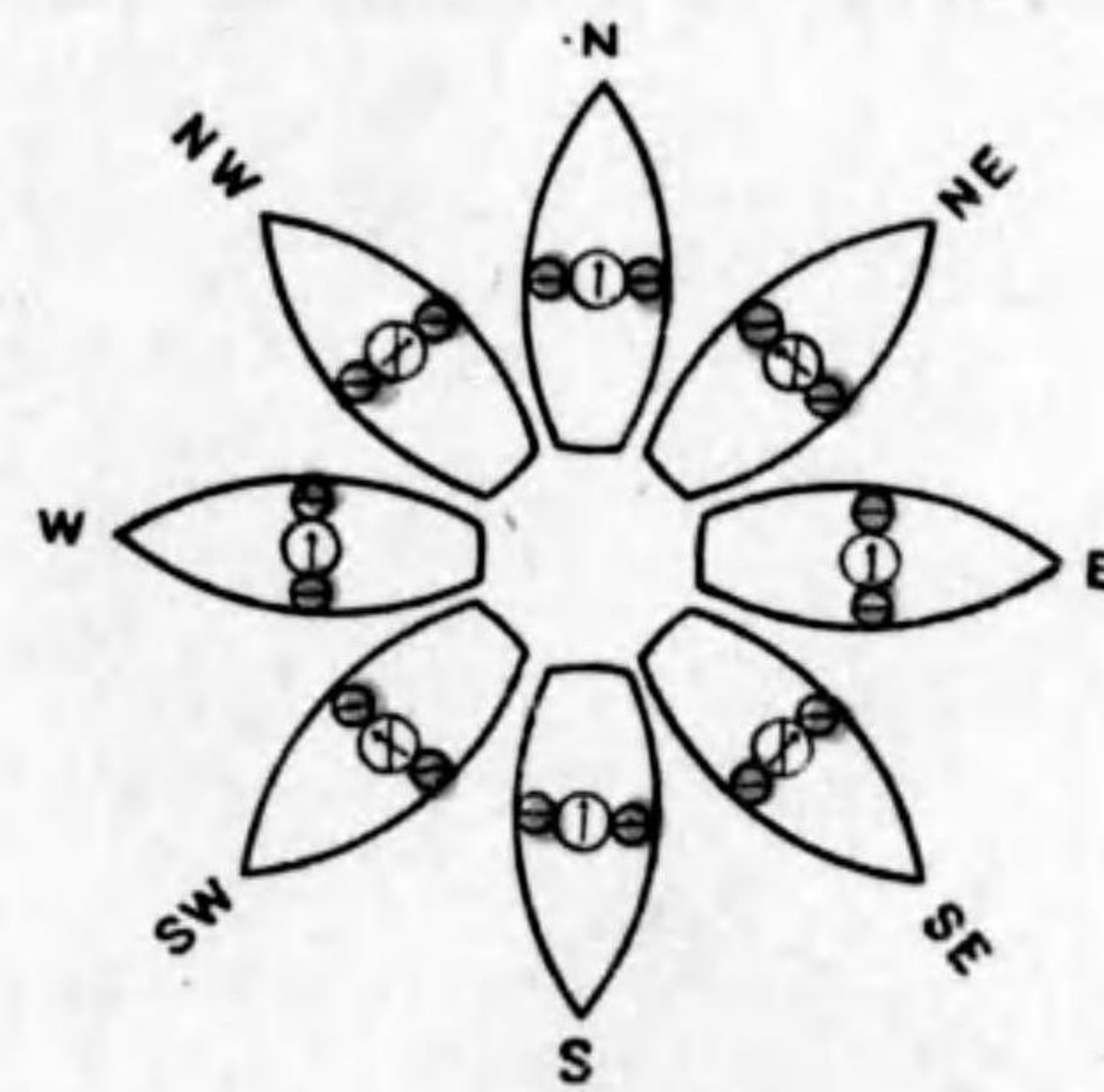

Fig. 30.

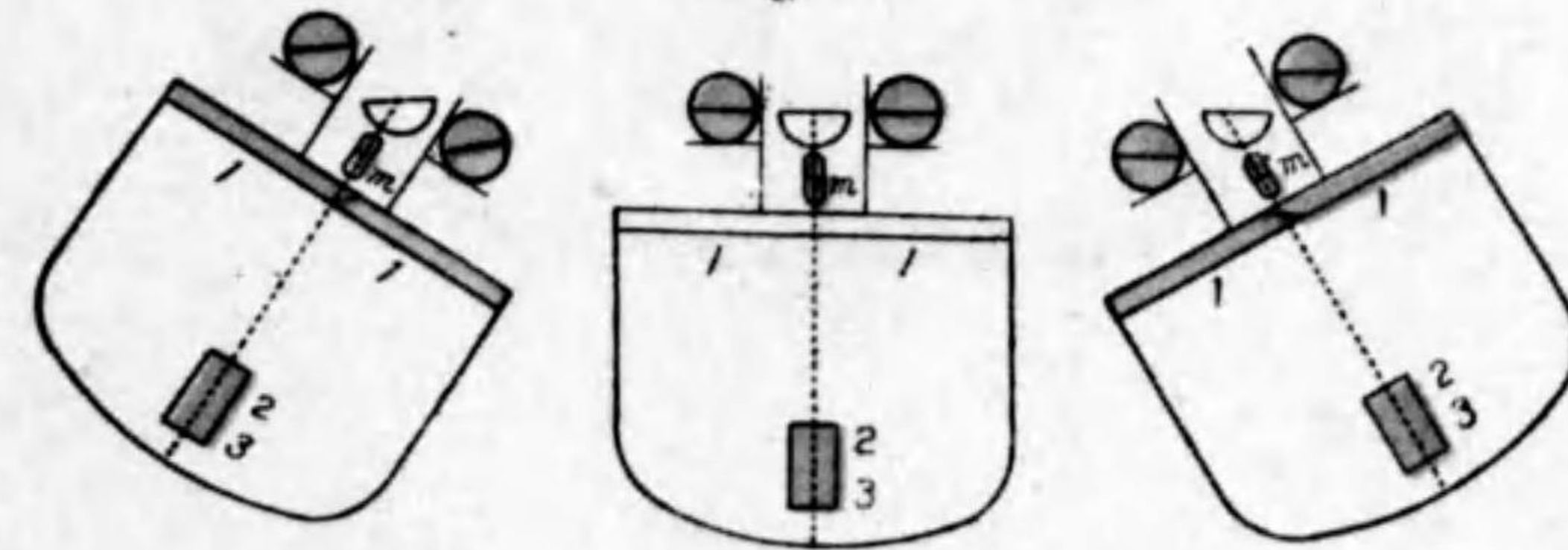

Fig. 31.

Lord Kelvin's Patent Deflector.

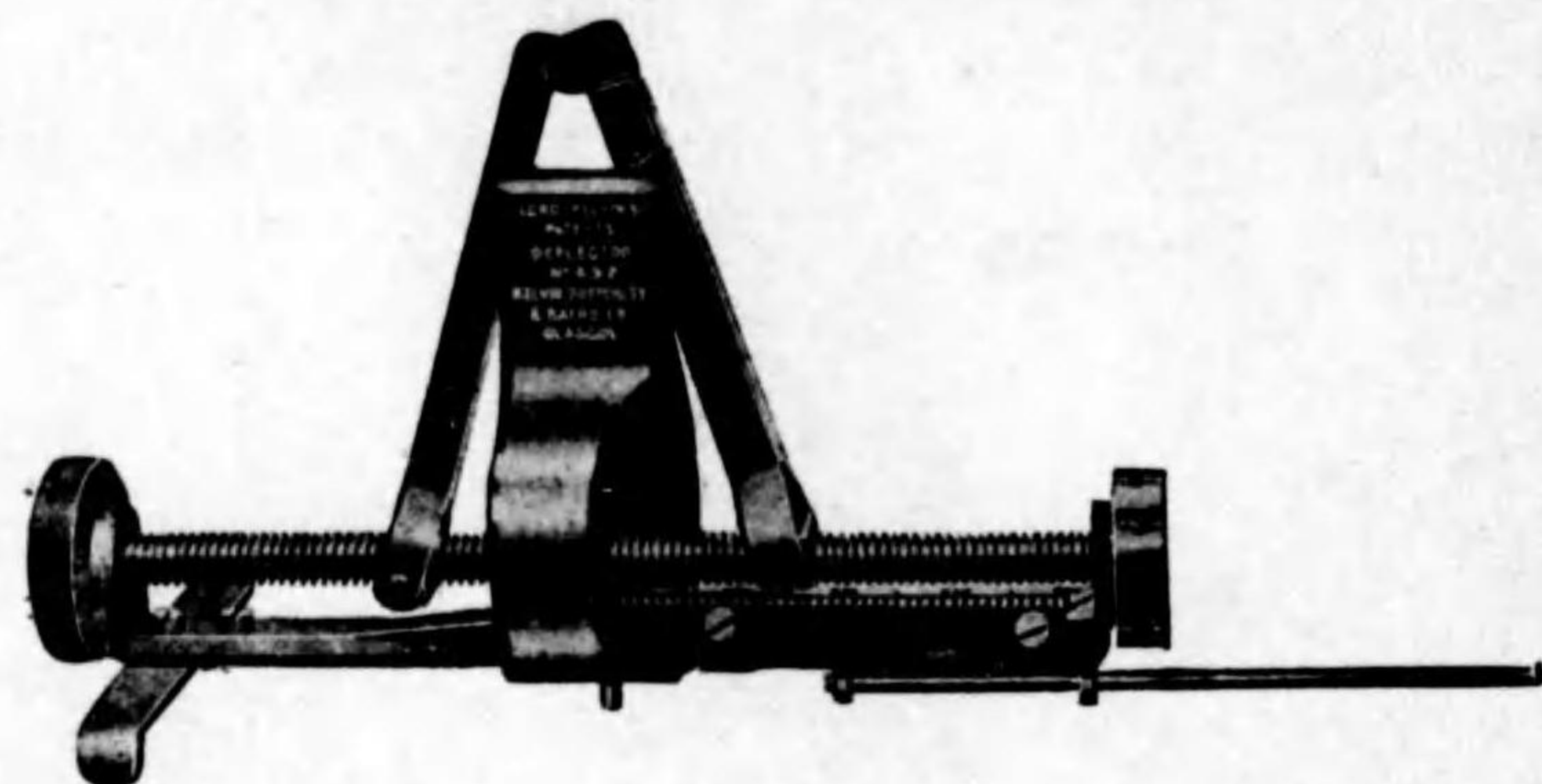
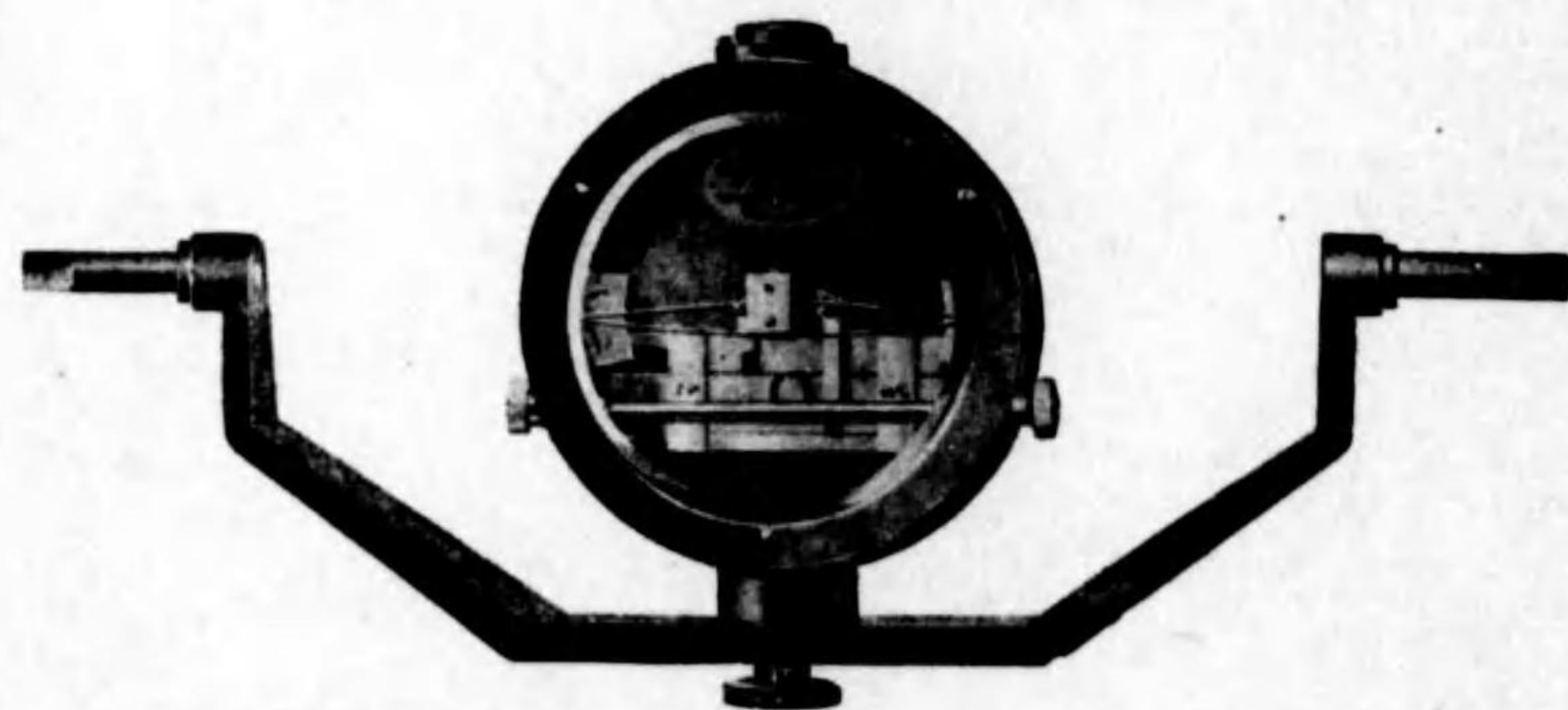

Fig. 32.

Lord Kelvin's Vertical Force Instrument.



NAPIER'S DIAGRAM
SHOWING CURVES OF DEVIATION

Ship.....

WEST DEVIATION

EAST DEVIATION

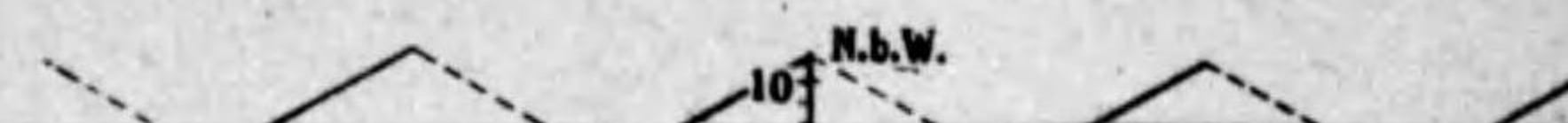

Fig. 31.

Lord Kelvin's Patent Deflector.

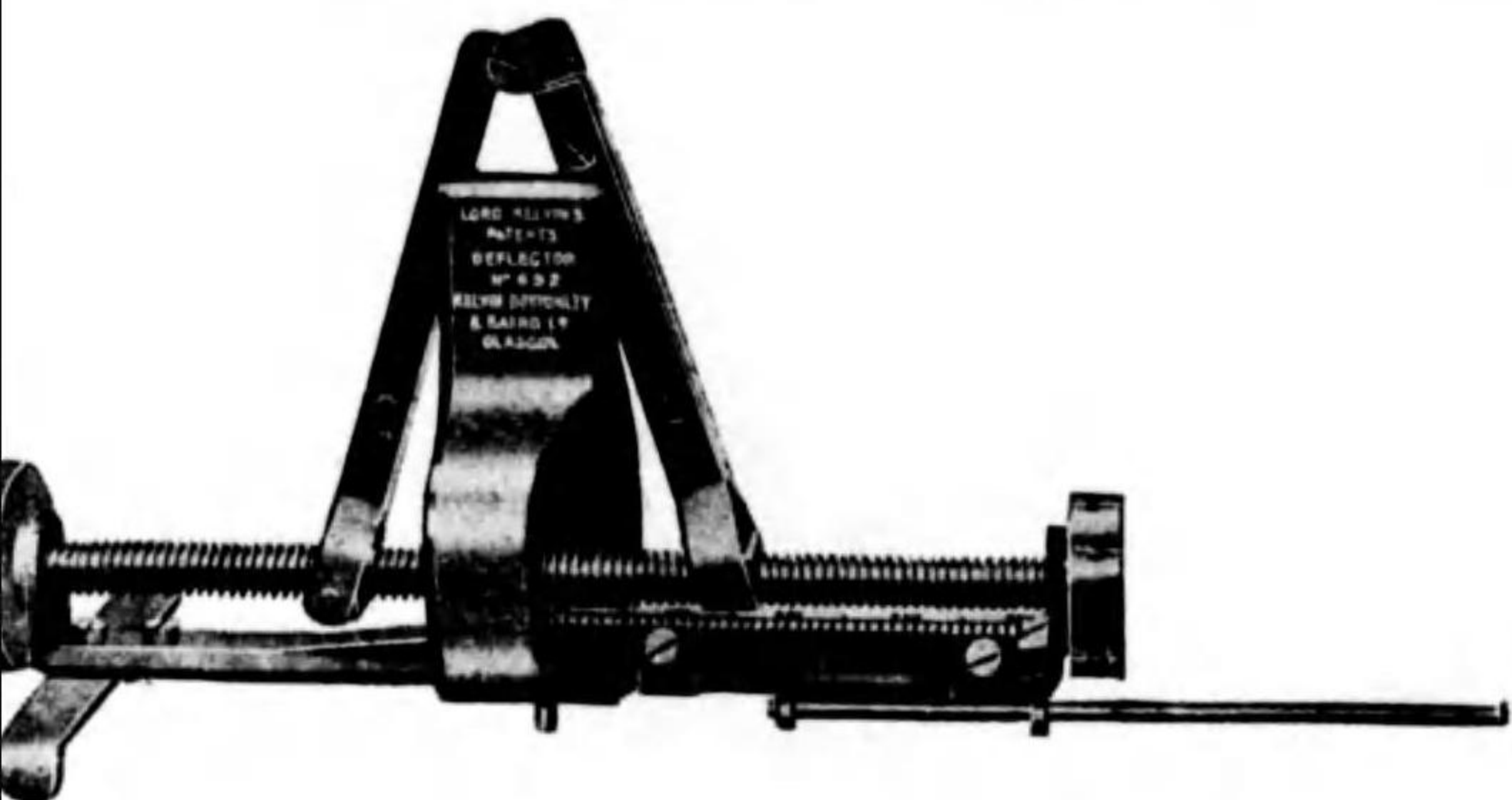
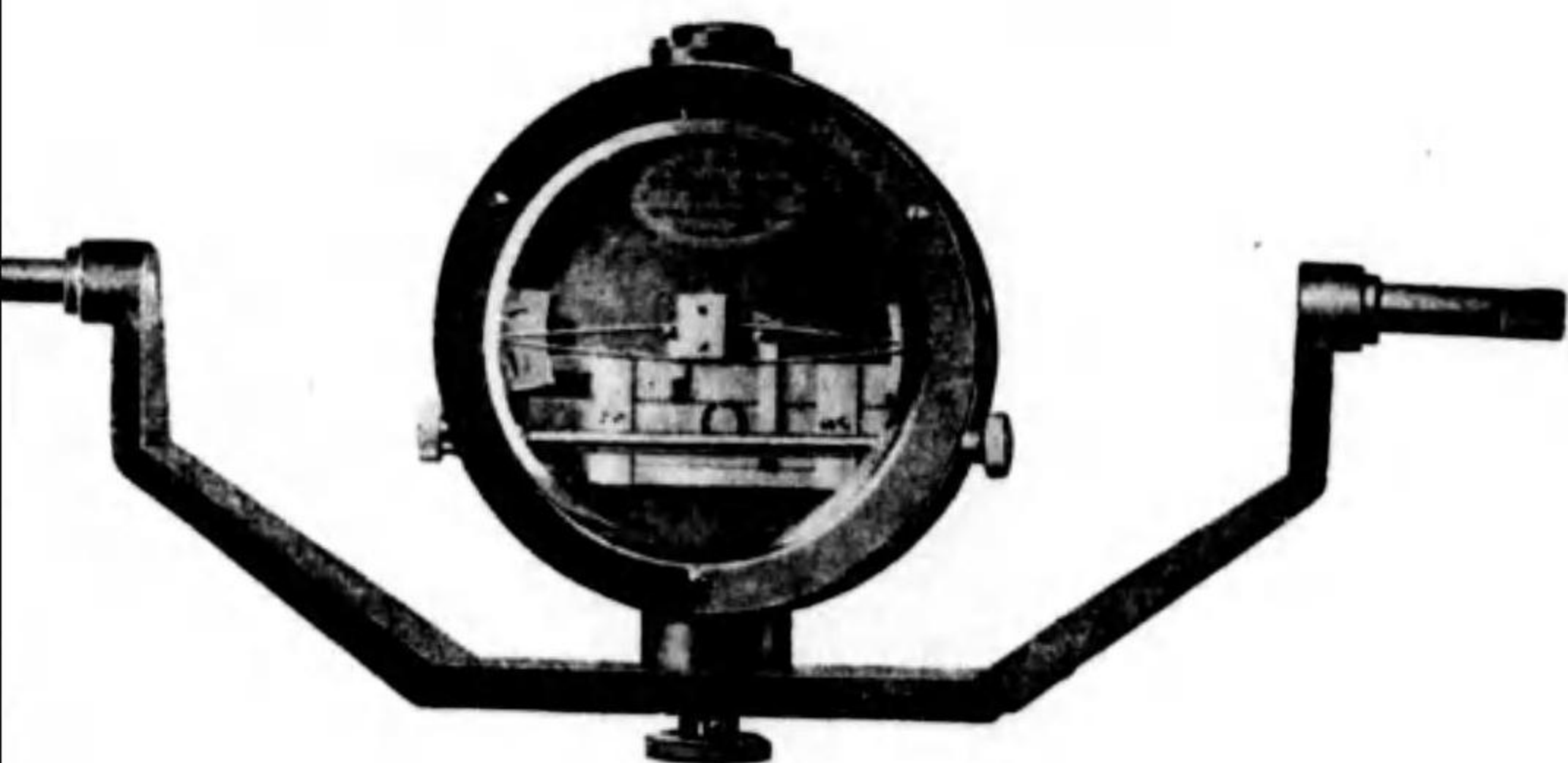

Fig. 32.

Lord Kelvin's Vertical Force Instrument.



NAPIER'S DIAGRAM
SHOWING CURVES OF DEVIATION

Ship
WEST DEVIATION EAST DEVIATION

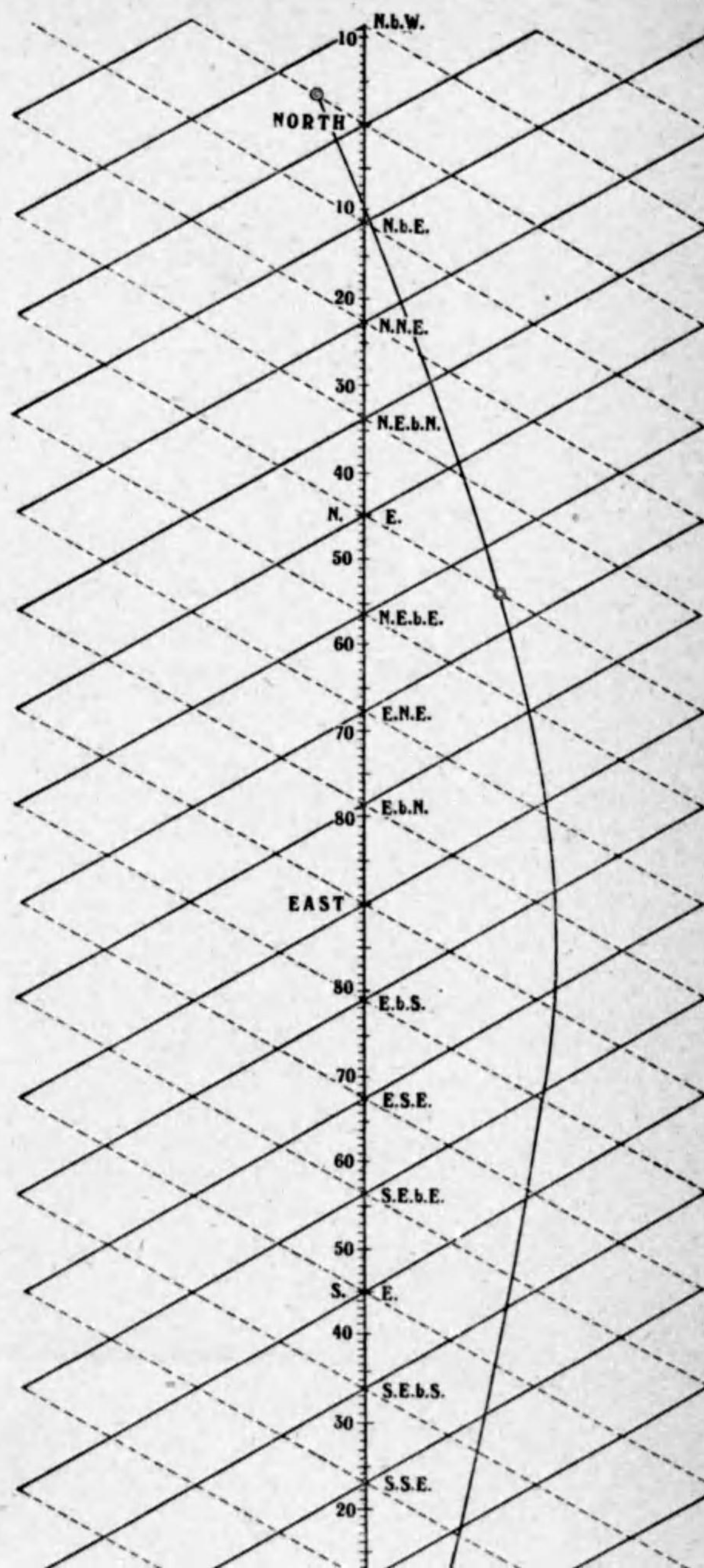

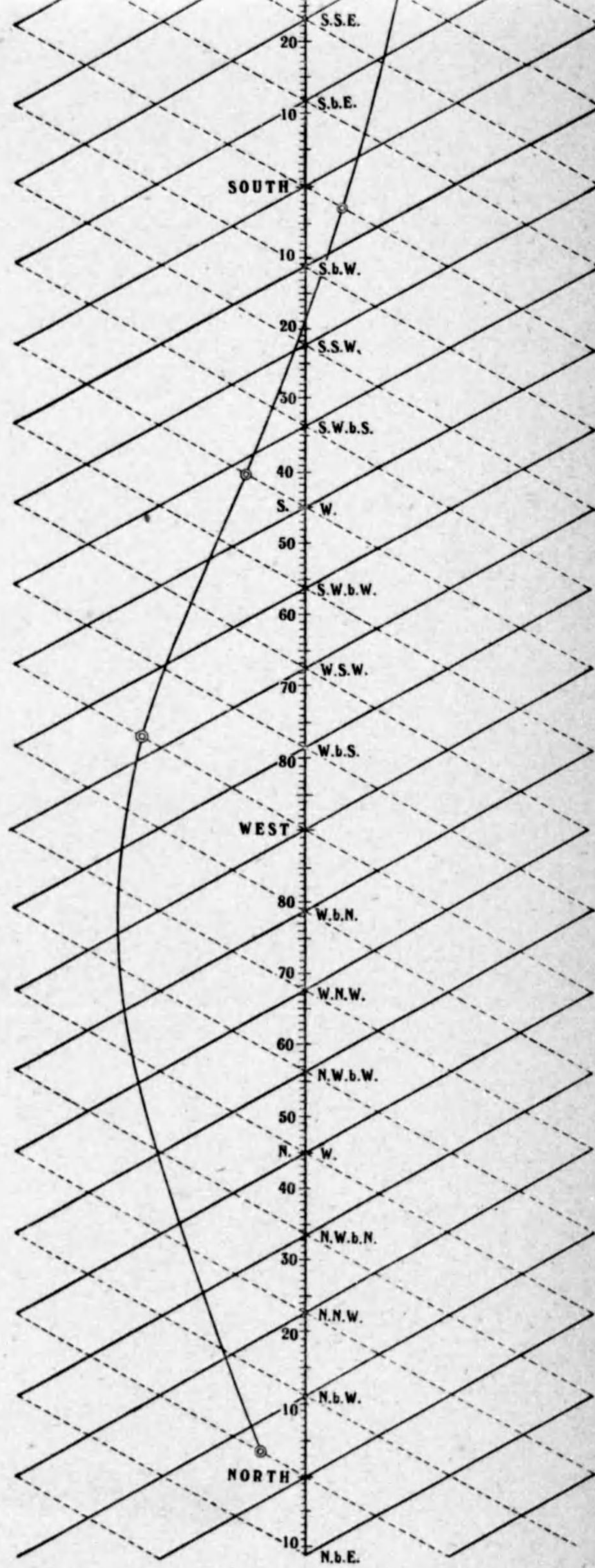

Place Lat Long

Date

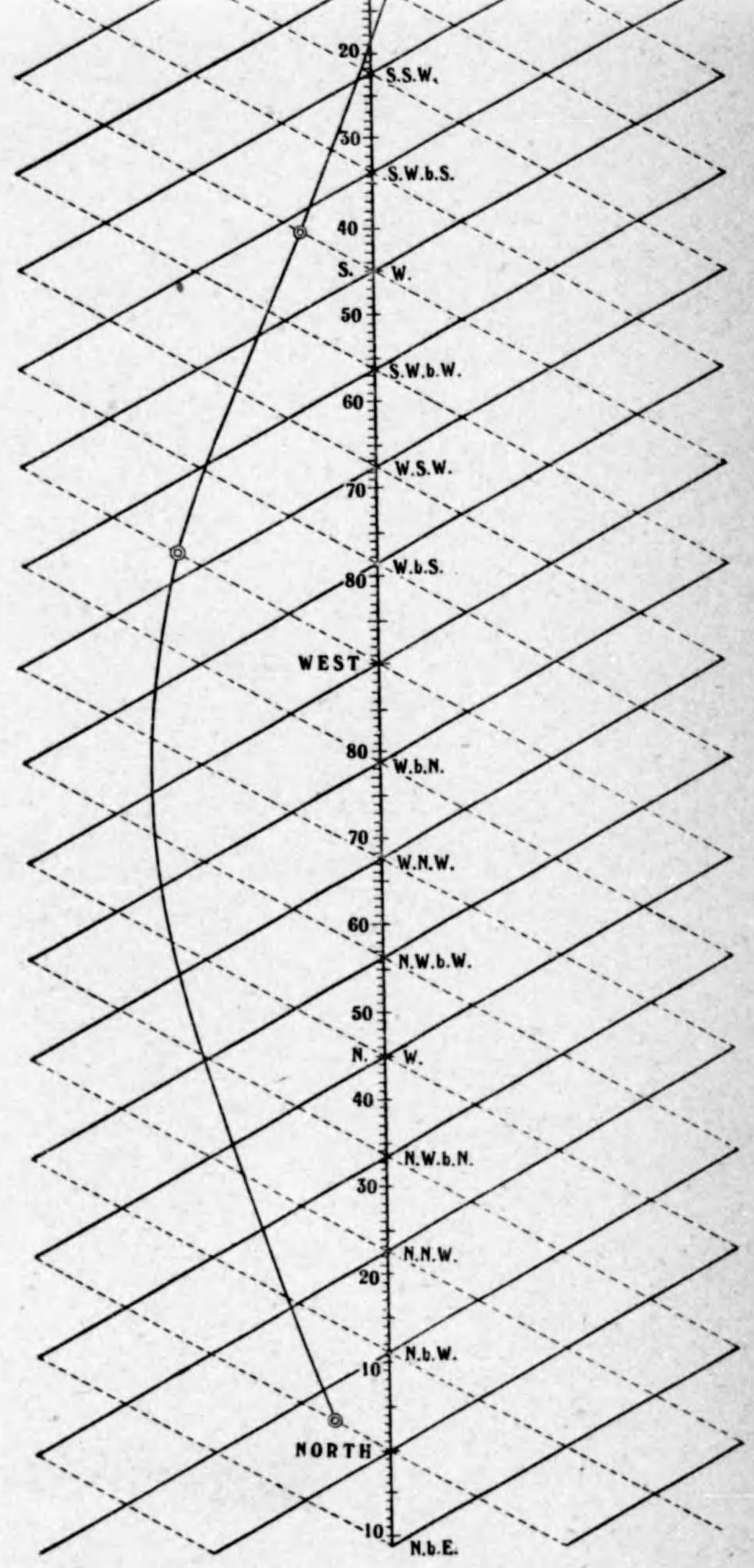

Place Lat. ° Long. °
 Date

發行承認番號ア 3799

昭和十四年五月十五日第一版發行
昭和十二年四月廿五日改訂第二版發行
昭和十八年九月十五日改訂第三版印刷
昭和十八年九月二十日改訂第三版發行

〔定價金壹圓參拾錢〕

著者 神戸高等商船學校

印刷兼發行者 神戸高等商船學校
海事教育振興會

會員番號二一〇〇九三

558.2
213

558.2-Ko137
1200500746540

終