

JAN 2 1924

U. S. Gov't
Master
Specification,
No. 85.

DEPARTMENT OF COMMERCE.

BUREAU OF STANDARDS.

George K. Burgess, Director.

CIRCULAR OF THE BUREAU OF STANDARDS, No. 160.

[April 8, 1924.]

UNITED STATES GOVERNMENT MASTER SPECIFICATION FOR ASPHALT FOR WATERPROOFING AND DAMP PROOFING.

FEDERAL SPECIFICATIONS BOARD.

SPECIFICATION No. 85.

This specification was officially adopted by the Federal Specifications Board on December 29, 1923, for the use of the Departments and Independent Establishments of the Government in the purchase of asphalt for waterproofing and damp proofing.

CONTENTS.

	Page.
1. General.....	1
2. Sampling.....	2
3. Laboratory examination.....	2

1. GENERAL.

This specification applies to asphalt intended for use with Asphalt Saturated Rag Felt for Roofing and Waterproofing (F. S. B. Spec. No. 86) as a plying cement in the construction of membrane waterproofing, or alone as a damp-proof coating.

This asphalt is suitable for damp proofing and waterproofing railroad bridges, tanks, retaining walls, dams, conduits, foundations of buildings, tunnels, subways, pools, reservoirs, etc. When tested by the methods contained in this specification, it shall conform to the following requirements:

(a) APPEARANCE.—Freshly melted material shall be black and glossy, and on aging one week its surface shall not become dull or show any separation of oil, grease, paraffin scale, or similar material.

- (b) MELTING POINT.—140 to 171° F.
- (c) PENETRATION AT 77° F.—25 to 50.
- (d) PENETRATION AT 32° F.—Minimum, 10.
- (e) PENETRATION AT 115° F.—Maximum, 100.
- (f) DUCTILITY.—Minimum, 15 cm.
- (g) VOLATILE MATTER AT 32 $\frac{1}{2}$ ° F.—Maximum, 1 per cent.
- (h) DECREASE IN PENETRATION AT 77° F. AFTER HEATING.—Maximum, 40 per cent.

(i) SOLUBLE IN CARBON BISULPHIDE.—Not less than 99 per cent.

(j) PACKING.—This asphalt shall be put up in steel drums or other suitable containers and be delivered at the site in original sealed packages as put up by the manufacturer. They shall be marked with the manufacturer's name and brand.

If required, deliveries will, in general, be sampled and tested by the following methods, but the purchaser reserves the right to use any additional information to ascertain whether the material meets the specification.

2. SAMPLING.

From each shipment select at random a number of packages equivalent to the cube root of the total number of packages included in the lot. If the cube root as calculated proves to be a fractional number, express it as the next higher digit.

Samples shall be taken at least 3 inches below the surface and at least 3 inches from the side of each container selected. A clean hatchet may be used if the material is hard enough to shatter and a broad, stiff putty knife if the material is soft. An auger, or brace and three-fourths inch bit, or other suitable means may also be used. Avoid contamination with superficial water, wooden slivers, or foreign matter.

The samples so taken shall be combined by melting together with constant stirring to prevent overheating, but the temperature must not exceed 200° C. (392° F.). When thoroughly melted, two 1-quart friction-top cans shall be filled with the well-mixed material, allowed to cool, tightly sealed, marked for identification with the manufacturer's name and brand, etc., and one transmitted to the testing laboratory. The other shall be retained for use in case of dispute.

3. LABORATORY EXAMINATION.

(a) APPEARANCE.—Carefully melt about 10 g of the asphalt at a temperature not exceeding 200° C. (392° F.) and pour it into a

small tin box or other suitable container provided with a cover. At least one-half the surface shall be free from froth or bubbles. Allow the asphalt to cool in a place free from drafts and dust. When cool, examine the surface, then cover with the lid and set aside for one week, after which period examine again. Immediately after cooling the surface shall be glossy black, and after standing one week the surface shall not show any dulling nor the separation of paraffin scale or greasy or oily material.

(b) MELTING POINT.—The melting point shall be determined by the "Standard Method of Test for the Softening Point of Bituminous Materials other than Tar Products" (Ring and Ball method), D 36-21, A. S. T. M. Standards, 1921, page 739, which is essentially as follows:

Apparatus.—(1) A brass ring five-eighths inch (15.9 mm) in inside diameter and one-fourth inch (6.4 mm) deep; thickness of wall, three thirty-seconds inch (2.4 mm). A variation of 0.01 inch (0.25 mm) on inside diameter and thickness of ring will be permissible. This ring shall be attached in a convenient manner to a No. 15 B & S gauge brass wire (diameter 0.0703 inch = 1.79 mm). (See fig. 1.) (2) A steel ball three-eighths inch (9.5 mm) in diameter, weighing between 3.45 and 3.55 g. (3) A glass beaker not less than $3\frac{1}{3}$ inches (8.5 cm) in diameter and measuring $4\frac{1}{8}$ inches (10.5 cm) in depth from the bottom of the flare. (A 600 cc beaker, low form, meets this requirement.) (4) A thermometer which shall conform to the following specifications:

Total length, 370-400 mm (14.57-15.75 inches).

Diameter, 6.5-7.5 mm (0.256-0.295 inch).

Bulb length, not over 14 mm (0.55 inch).

Bulb diameter, 4.5-5.5 mm (0.177-0.217 inch).

The scale shall be engraved upon the stem of the thermometer, shall be clear-cut and distinct, and shall run from 0 to 80° C. (32 to 176° F.) in $\frac{1}{5}^{\circ}$ C. divisions. It shall commence not less than 7.5 cm (2.95 inches) above the bottom of the bulb. The thermometer shall be furnished with an expansion chamber at the top and have a ring for attaching tags. It shall be made of a suitable quality of glass and be so annealed as not to change its readings under conditions of use. It shall be correct to 0.25° C. (0.45° F.) as determined by comparison at full immersion with a similar thermometer calibrated at full immersion by the U. S. Bureau of Standards.

Preparation of sample.—The asphalt shall be melted and stirred thoroughly, care being taken to avoid incorporating air bubbles in

the mass, and then poured into the ring so as to leave an excess on cooling. The ring while being filled should rest on a brass plate which has been amalgamated to prevent the asphalt from adhering to it. After cooling the excess asphalt shall be cut off cleanly with a slightly heated knife.

Procedure.—Assemble the apparatus as shown in Figure 1. Fill the beaker to a depth of approximately $3\frac{1}{4}$ inches (8.25 cm) with freshly boiled distilled water at 5°C . (41°F). Place the

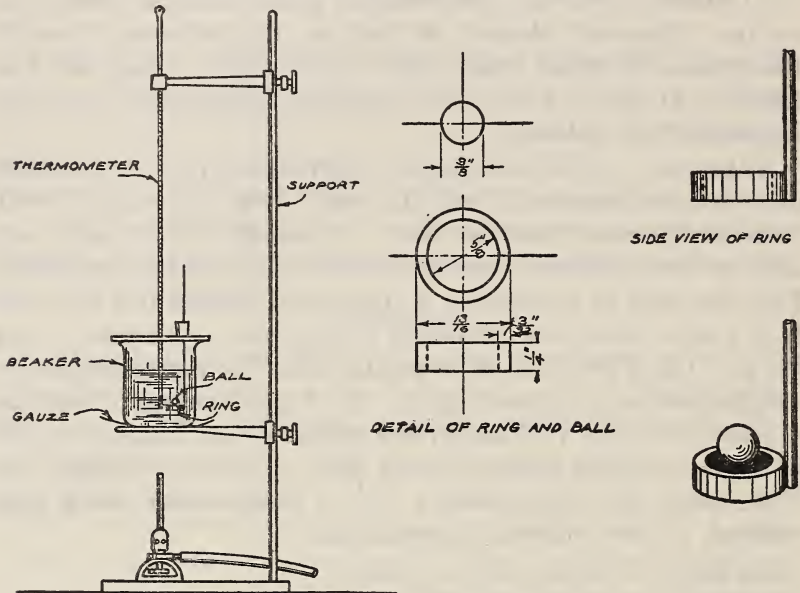

FIG. 1.—Melting point apparatus.

ball in the center of the upper surface of the asphalt in the ring and suspend it in the water, so that the lower surface of the filled ring is exactly 1 inch (2.54 cm) above the bottom of the beaker and its upper surface is 2 inches (5.1 cm) below the surface of the water. Allow it to remain in the water for 15 minutes before applying heat. Suspend the thermometer so that the bottom of the bulb is level with the bottom of the ring and within one-fourth inch (0.64 cm), but not touching the ring.

Apply the heat in such a manner that the temperature of the water is raised 5°C . (9°F .) each minute until the asphalt melts and touches the bottom of the beaker. The temperature recorded by the thermometer at the instant the asphalt touches the bottom of the beaker shall be taken as the melting point.

The rate of rise of temperature shall be uniform and shall not be averaged over the period of the test. The maximum permissible variation for any minute period after the first three shall be $\pm 0.5^{\circ}$ C. (0.9° F.). All tests in which the rate of rise in temperature exceeds these limits shall be rejected.

The use of freshly boiled distilled water is essential, as otherwise air bubbles may form on the specimen and affect the accuracy of the results. Rigid adherence to the prescribed rate of heating is absolutely essential in order to secure accuracy of results.

(c) PENETRATION AT 77° F.—The penetration shall be determined by the "Standard Method of Test for Penetration of Bituminous Materials," D 5-21, A. S. T. M. Standards, 1921, page 728, which is essentially as follows:

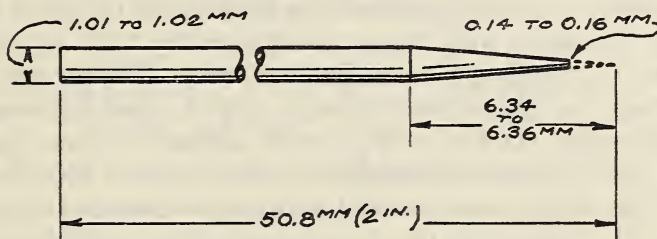

FIG. 2.—Penetration needle.

Apparatus—(1) *Container*.—The container for holding the asphalt to be tested shall be a flat bottomed, cylindrical dish, 55 mm ($2\frac{3}{8}$ inches) in diameter and 35 mm ($1\frac{3}{8}$ inches) deep.¹

(2) *Needle*.—The needle (fig. 2) shall be a cylindrical steel rod 50.8 mm (2 inches) long, having a diameter of 1.01 to 1.02 mm and a taper of 6.34 to 6.36 mm measured on the axis. After tapering the point shall be blunted by grinding off to a truncated cone, the smaller base of which shall be from 0.14 to 0.16 mm in diameter.

(3) *Water bath*.—The water bath shall be maintained at a temperature not varying more than 0.1° C. from 25° C. (77° F.). The volume of the water shall be not less than 10 liters, and the sample shall be immersed to a depth of not less than 10 cm (4 inches) and shall be supported on a perforated shelf not less than 5 cm (2 inches) from the bottom of the bath.

(4) *Penetration machine*.—Any apparatus which will allow the needle to penetrate without appreciable friction and which is accurately calibrated to read in hundredths of a centimeter.

¹ A Gill style ointment box, deep pattern, made by the American Can Co., and of 3-ounce capacity meets this requirement.

(5) *Transfer dish.*—The transfer dish for the container shall be a small dish or tray of such capacity as will insure complete immersion of the container during the test. It shall be provided with some means which will insure a firm bearing and prevent rocking of the container.

Preparation of sample.—The sample shall be completely melted at the lowest possible temperature and stirred thoroughly until it is homogeneous and free from air bubbles. It shall then be poured into the sample container to a depth of not less than 15 mm (five-eighths inch). The sample shall be protected from dust and allowed to cool in air at a temperature not lower than 18° C. (65° F.) for one hour. It shall then be placed in the water bath along with a transfer dish and allowed to remain one hour.

Procedure.—In making the test the sample shall be placed in the transfer dish filled with water from the water bath to a depth sufficient to completely cover the container. The transfer dish containing the sample shall then be placed upon the stand of the penetration machine. The needle, loaded with the specified weight (100 g), shall be adjusted to make contact with the surface of the sample and the dial adjusted to zero or its reading noted. The needle shall then be released for the specified period of time (five seconds), after which its penetration shall be measured.

At least three tests shall be made at points on the surface of the sample not less than 1 cm (three-eighth inch) from the side of the container and not less than 1 cm (three-eighth inch) apart. After each test the sample and transfer dish shall be returned to the water bath, and the needle shall be carefully wiped toward its point with a clean, dry cloth to remove all adhering asphalt. The penetration reported shall be the average of at least three tests whose values shall not differ more than four points between maximum and minimum.

(d) PENETRATION AT 32° F.—This shall be determined as in 3 (c) at a temperature of 0° C. (32° F.) under a 200 g load and for a period of 60 seconds, instead of a temperature of 25° C. (77° F.) a load of 100 g, and a period of five seconds.

(e) PENETRATION AT 115° F.—This shall be determined as in 3 (c) at a temperature of 46° C. (115° F.) under a 50 g load and for a period of five seconds, instead of a temperature of 25° C. (77° F.), a load of 100 g, and a period of five seconds.

(f) DUCTILITY.—The ductility shall be determined by the "Tentative Method of Test for Ductility of Bituminous Materials," (D 113-22T, Proceedings A. S. T. M., 1922, vol. 22, page 807). This method is essentially as follows:

Apparatus.—(1) *Mold.*—The mold shall be of the shape shown in Figure 3. It shall be made of brass, the ends *b* and *b'* being known as clips and the parts *a* and *a'* as sides of the mold. The dimensions of the mold shall be as follows:

	cm
Total length (internal).....	7.45-7.55
Distance between clips.....	2.97-3.06
Width of clips at mouth.....	1.98-2.02
Width of briquet at minimum cross section (halfway between clips).....	.99-1.01
Thickness of briquet throughout.....	.99-1.01

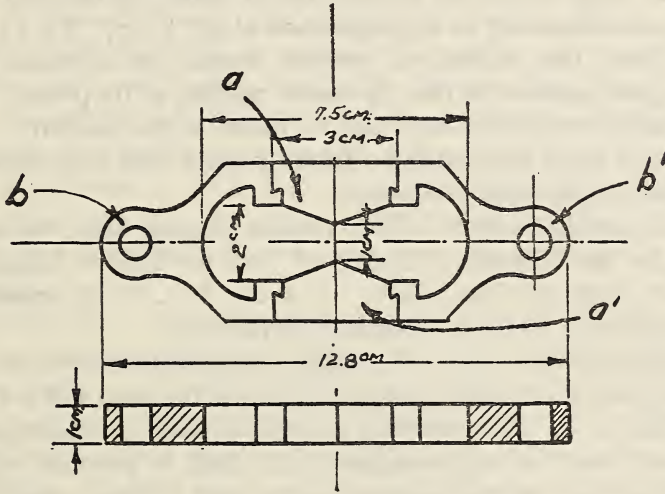

FIG. 3.—Dow ductility mold.

(2) *Water bath.*—Same as in 3 (c) (3).

(3) *Testing machine.*—Any apparatus may be used for pulling the briquet of bitumen apart that is so constructed that the briquet will be continuously immersed in water and the two clips pulled apart at a uniform rate of 5 cm per minute.

Procedure.—The mold shall be assembled on a brass plate, and the surface of the plate and the interior surfaces of the side pieces *a* and *a'* of the mold shall be thoroughly amalgamated, so as to prevent the asphalt from sticking. The asphalt shall be completely melted at the lowest temperature at which it will be thoroughly fluid and then poured into the standard mold. In filling, the asphalt shall be poured in a thin stream back and forth from end to end of the mold until it is more than level full. After cooling to room temperature for 30 minutes the excess asphalt shall be cut off by means of a hot putty knife, so that the mold will be just level full.

The brass plate and mold containing the briquet shall then be placed in the water bath and kept at a temperature of 25° C. (77° F.) for at least one and one-half hours, when the briquet shall be removed from the plate and the side pieces *a* and *a'* detached.

The rings at each end of the clip shall then be attached to the pins or hooks in the ductility machine and the two clips pulled apart at a uniform rate of 5 cm per minute (± 5 percent). While the test is being made the water in the tank of the ductility machine shall cover the briquet by at least 2.5 cm and shall be kept continuously at a temperature of 25° C. (77° F.) ($\pm 0.5^\circ$ C.). When the briquet of asphalt breaks, the distance from the original position of the clip before pulling to its present position shall be measured and shall be taken as the ductility. The average of three tests shall be taken, except that any obviously abnormal result shall be rejected.

(g) VOLATILE MATTER.—The volatile matter shall be determined by the "Standard Method of Test for Loss on Heating of Oil and Asphaltic Compounds," D 6-20, A. S. T. M. Standards, 1921, page 731, which is essentially as follows:

Apparatus.—(1) *Oven.*—A constant-temperature oven so constructed that the temperature in all parts of the oven will not vary more than 1° C. An oven with a revolving shelf is recommended. The oven shall be well ventilated, and shall be provided with a window so that the thermometer can be read without opening the door. The source of heat shall be either gas or electricity.

(2) *Thermometer.*—A thermometer graduated in $1/5^\circ$ C. and correct to 0.25° C. (0.45° F.). It shall be calibrated at total immersion. The thermometer shall preferably be of a type suitable for use only at temperatures between 150° and 175° C.

(3) *Container.*—Same as in 3 (c) (1).

Preparation of sample.—The sample as received shall be melted and thoroughly stirred to insure a complete mixture before the portion for test is removed.

Procedure.—Place 50 g of the asphalt in a tared container and place in the constant-temperature oven, which has previously been heated to 163° C. (325° F.). Maintain this temperature for five hours, then remove the sample from the oven, cool and weigh, and compute the loss as volatile matter.

The thermometer shall be immersed for the depth of its bulb in a separate 50 g sample of the asphalt, placed in a similar container. During the five-hour period the temperature shall not vary more than 1° C. All tests showing a greater variation in

temperature shall be rejected. If an oven of the revolving-shelf type is used, the shelf shall be rotated at from five to six revolutions per minute during the test.

(h) PENETRATION AT 77° F. AFTER HEATING.—The sample from tests 3 (g) shall be melted at a temperature not exceeding 200° C. (392° F.) until fluid and thoroughly mixed. It shall then be allowed to cool to room temperature and tested for penetration as in 3 (c) at a temperature of 25° C. (77° F.) under a load of 100 g and for a period of five seconds.

(i) MATTER SOLUBLE IN CARBON BISULPHIDE.—One g of the asphalt shall be placed in a beaker of 100 to 150 cc capacity, covered with cold carbon bisulphide and set aside for about 15 minutes and the liquid stirred every few minutes until the lumps break up and the asphalt goes into solution. The solid particles shall be allowed to settle and the carbon bisulphide solution of the asphalt decanted through a weighed Gooch crucible, prepared with a mat of asbestos fiber of a thickness that will scarcely transmit light.

The sediment remaining in the beaker shall be crushed with a stirring rod and a little more carbon bisulphide added. The sides of the beaker also shall be washed down with carbon bisulphide. The contents of the beaker shall be poured into the crucible and all sediment washed from the beaker into the crucible with carbon bisulphide. Suction may be used to aid in filtering. The sediment on the filter shall be washed with carbon bisulphide until the washings run through colorless. The crucible shall be set aside in a place free from dust until the carbon bisulphide evaporates and then placed in an oven at the temperature of boiling water for one hour. It shall then be cooled and weighed and the soluble matter computed.

ADDITIONAL COPIES
OF THIS PUBLICATION MAY BE PROCURED FROM
THE SUPERINTENDENT OF DOCUMENTS
GOVERNMENT PRINTING OFFICE
WASHINGTON, D. C.
AT
5 CENTS PER COPY

▽

