

NPS ARCHIVE
1956.06
HOLSHOUSER, J.

**THE EFFECTS OF AIRPLANE STABILITY
CHARACTERISTICS ON PILOT RADAR TRACKING ERROR**

J. A. Holshouser, Jr.
and
W. Spangenberg, Jr.

DUDLEY KNOX LIBRARY
NAVAL POSTGRADUATE SCHOOL
MONTEREY CA 93943-5101

LIBRARY
OF NAVAL POSTGRADUATE SCHOOL
MONTEREY, CALIFORNIA



THE EFFECTS OF AIRPLANE STABILITY CHARACTERISTICS
ON PILOT RADAR TRACKING ERROR

J. A. Holshouser, Jr.
W. Spangenberg, Jr.

Aeronautical Engineering Report No. 353

1 June 1956

Submitted in partial fulfillment of the requirements
for the degree of Master of Science in Engineering from
Princeton University, 1956.



ABSTRACT

Using a flight simulator consisting of an airplane cockpit, an electronic analog computer, and associated electrical and electronic equipment, variation in pilot's mean radar tracking error summed over a two-minute test run was determined as a function of airplane longitudinal damping ratio and frequency of oscillation.

Test results obtained were reasonable and repeatable within twenty percent where checked for a given pilot-longitudinal stability configuration.

The test method used is considered sound and suitable for further development and use.

ACKNOWLEDGEMENTS

The authors extend special thanks to Professor Edward Seckel and Mr. Enoch J. Durbin, whose help and guidance were invaluable in avoiding many rocks and shoals during the course of this investigation.

The technical assistance rendered willingly, and often at inconvenient hours, by Messrs. Martin Zeh and John Whitley was essential to the completion of this endeavor and is deeply appreciated.

Thanks are also expressed to the pilots who gave their time to fly the simulator and whose patience did not fail when difficulties were encountered and rescheduling was necessary.

The authors wish to thank the many others whose assistance in various ways was of great benefit.



TABLE OF CONTENTS

	<u>Page Number</u>
Introduction	1
Equipment and Procedure	3
Results and Discussion	14
Conclusions and Recommendations	21
Tables	23
Figures	29
Appendix A	51

INTRODUCTION

In aerial combat it is necessary for an aircraft to track its target before and during the firing interval. As the target aircraft changes course and altitude a tracking error is introduced, reduction of which requires the attacking pilot to maneuver his aircraft. The time interval required for the attacking pilot to reduce this tracking error depends in part upon the response of the aircraft to the pilot's control stick movements.

As aircraft design evolves into higher and higher performance capability, the airplane longitudinal stability derivatives are changed and the responses of the aircraft to stick movement are varied accordingly. As the aircraft responses vary, the ability of the pilot to reduce tracking error is affected. It is the purpose of this thesis to determine the effect of variation in the aircraft's longitudinal stability derivatives on the pilot's ability to track. The limited time available precluded the investigation of the effects of lateral and directional stability changes.

A flight simulator incorporating an electronic analog computer was utilized to simulate a flying aircraft. The analog computer afforded the opportunity of making arbitrary changes in stability parameters. A radar scope was used to present a "target" and the pilot's tracking error was measured.

In order to obtain a representative cross-section of pilot tracking ability, five pilots were used as test subjects. Tests were conducted and data evaluated on sixteen different configurations of longitudinal short period damping and frequency of oscillation. These

various configurations of damping and frequency were selected arbitrarily as a first venture in this direction. The longitudinal stability configurations, as well as the forms of data presentation, are a result of trial and error in the absence of established procedures.



EQUIPMENT AND PROCEDURE

I. Equipment.

Tests were conducted with five Naval aviators, all experienced in propeller and jet fighter type aircraft, using a flight simulator consisting of a North American "Navion" airplane, a Goodyear electronic analog computer, and necessary additional electronic and electrical equipment. Figure 1 is a photograph of the flight simulator airplane. The analog computer is not shown. Control force gradients and friction levels were adjusted to equal those of the "Navion" at a flight speed of 120 mph. Representation of the aircraft stability characteristics on the analog computer is such that individual parameters or derivatives may be changed as desired, thus making possible the simulation of any required aircraft stability configuration. The analog computer circuit diagram is shown in Fig. 3. In this investigation, only the effective airplane damping in pitch and inertia were changed. Rudder control is not utilized in the flight simulator.

A cathode ray tube simulating a C-scan radar scope is mounted on the cowling of the aircraft, aligned with the pilot's eyes. The scope presentation consists of a target pip and a horizon line. Cross-hairs engraved on the lucite scope cover are illuminated to represent those of an optical gunsight. Figure 2 illustrates the cockpit of the flight simulator. An electronic random noise generator is used to provide target pip motion in elevation and in azimuth about a zero reference point. The output of the electronic random noise generator is filtered to produce an output frequency band of zero to one radian per second. Attenuation above one radian per second is 42 db in the first

decade above one radian per second and 60 db per decade above the first decade. This random motion simulates target airplane response to atmospheric disturbances, seen from the dead-astern position in a tail-chase. Both zero reference point for the target pip and the horizon line move in response to flight simulator control movements, as if viewed through an optical gunsight of magnification one. With the radar scope fifteen inches from the pilot's eyes, an error of one inch on the radar scope simulates a gunsight error of 66 mils.

Four displacement quantities were measured during the tests as voltages representing the displacements in inches. Using a telemeter system built by the Applied Science Corporation of Princeton (ASCOP Model MER-2), frequency-modulated signals representing the following quantities were transmitted to the remotely-located telemeter receiver installation:

X noise, measured horizontally, positive to the right, from the zero reference point to the target pip.

Y noise, measured vertically, positive upward, from the zero reference point to the target pip.

X error, measured parallel to the gunsight level cross-hair, positive to the right, from the cross-level cross-hair to the target pip.

Y error, measured parallel to the gunsight cross-level cross-hair, positive upward, from the level cross-hair to the target pip.

A diagram of the target presentation and quantities measured is presented in Fig. 5.

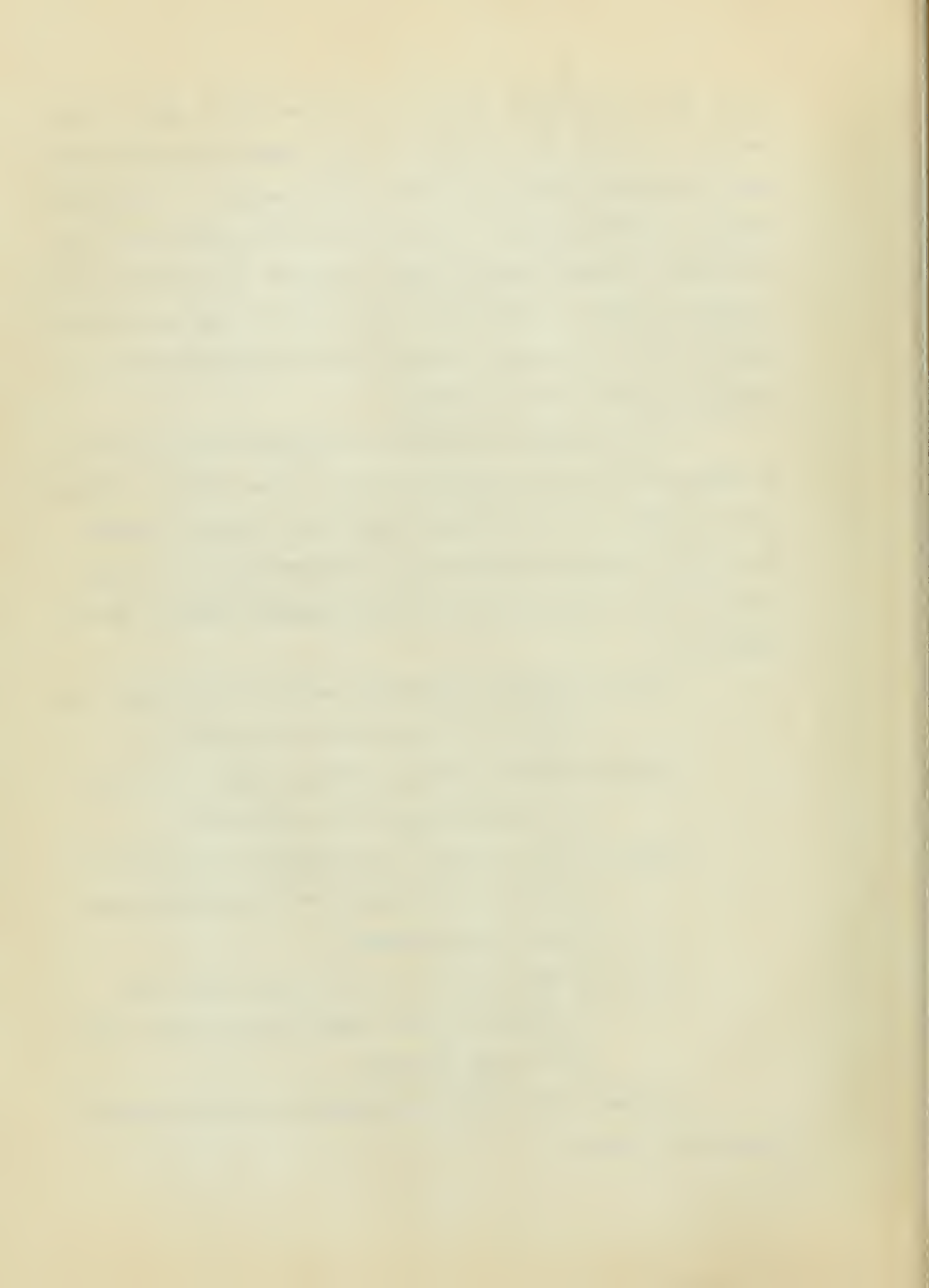

At the telemeter receiver installation, these frequency-modulated displacement signals were recorded on magnetic tape, using an Ampex Model 309C recorder. See Fig. 4 for block diagram of test signal path. A recording oscillograph (Brush or Sanborn) was employed after each test to monitor the magnetic tape for telemeter signal fade, displacements exceeding simulator limits, and other occurrences which might invalidate the test record.

The magnetic tape record of each of the four measured quantities, after conversion to a fluctuating DC signal in the translator section of the telemeter ground station, served as the input voltage for an analog computer reducing circuit. Output of the telemeter translators was determined in volts per inch scope displacement as follows:

X noise	--	27.82	volts/inch
Y noise	--	27.04	" "
X error	--	40.00	" "
Y error	--	40.00	" "

For details of the analog computer reducing circuit see section on data reduction below, and also Figs. 15 and 16.

Because of the remote location when this investigation was undertaken of the telemeter receiver installation and tape recorder from the analog computer, a means was required for transmitting the test records from the Ampex recorder to the analog computer. The distance involved precluded the stringing of wires, so it was decided to employ a portable tape recorder to record the test information in a form which would permit transportation to the analog computer for playing back into the reducing circuit. Details of the portable tape

recorder and associated circuitry are presented in Appendix A, including Figs. A-1 and A-2.

II. Development of Aircraft Stability Configurations for Tests.

In the design of the flight simulator, the six linearized equations describing the dynamic motion of the airplane were written, assuming no coupling between longitudinal and lateral modes of motion. The coefficients in these equations were then estimated and the numerical equations were synthesized on the analog computer. Coefficients were adjusted empirically to match flight test data obtained at a gross weight of 2850 lbs, center of gravity at 27.9% m.a.c., altitude of 5,000 ft. and indicated airspeed of 120 mph. The final equations give an accurate prediction of the angles of pitch, yaw and roll with less accurate results for velocity increment, angle of attack and angle of sideslip. The latter three parameters are not used in the "Navion" simulator.

The longitudinal equations of motion for the flight simulator are:

$$\text{(drag)} \quad -\dot{u} = .0278u + .150\theta - .0312\alpha$$

$$\text{(lift)} \quad -10\dot{\alpha} = 17.2\alpha - 10.0\dot{\theta} + 3.00u$$

$$\text{(pitching moment)} \quad \ddot{\theta} = -.343\dot{\theta} - 3.13\dot{\alpha} - 12.1\alpha + 50.8\Delta S$$

where: u = incremental velocity

α = angle of attack

θ = angle of pitch

ΔS = distance moved by control yoke, inches

The equations above were set up on the flight simulator analog computer. The frequency of target motion simulated is high enough for

the tracking airplane's response to control movements to be unaffected by the longitudinal phugoid mode. Therefore, to facilitate computation of changes in longitudinal stability, the longitudinal short period mode was approximated by setting the incremental velocity equal to zero and dropping the drag equation. This approximation was used only in computing stability changes; the analog computer circuit in the flight simulator includes all three equations presented above. Rearranging the lift and pitching moment equations:

$$(17.2 + 10D)\alpha - (10D)\Theta = 0 = \frac{1}{2}(C_{D\alpha} - C_L)\alpha + \left(\frac{C_L}{2}\right)\Theta$$

$$(12.1 + 3.13D)\alpha + (.343D + D^2)\Theta = 0 = -C_{m\alpha}\alpha - C_{m_{D\alpha}}D\alpha - C_{m_{D\Theta}}D\Theta + hD^2\Theta$$

Dividing the lift equation by 10.0 and the pitching moment equation by h:

$$(1.72 + D)\alpha - D\Theta = 0$$

$$\left(-\frac{C_{m\alpha}}{h} - \frac{C_{m_{D\alpha}}}{h}\right)\alpha + \left(-\frac{C_{m_{D\Theta}}}{h}D + D^2\right)\Theta = 0$$

Rewriting the pitching moment equation in terms of arbitrary new derivatives:

$$(-C_{m\alpha}^* - C_{m_{D\alpha}}^*D)\alpha + (-C_{m_{D\Theta}}^*D + hD^2)\Theta = 0$$

where: $C_{m\alpha}^* \equiv \frac{C_{m\alpha}}{h_{NAVIO}}$
etc.

or: $(12.1 - C_{m_{D\alpha}}^*D)\alpha + (.343D + hD^2)\Theta = 0$

The parameters $C_{m_{D\alpha}}^*$ and h^* remain in symbolic form so that their identity is retained. Variations in these two parameters will provide the desired aircraft longitudinal stability configurations.

Forming a determinant and writing the characteristic equation:

$$\begin{vmatrix} (1.72 + \lambda) & -\lambda \\ (12.1 - C_{m_{D\alpha}}^*\lambda) & (.343\lambda + h^*\lambda^2) \end{vmatrix} = 0$$

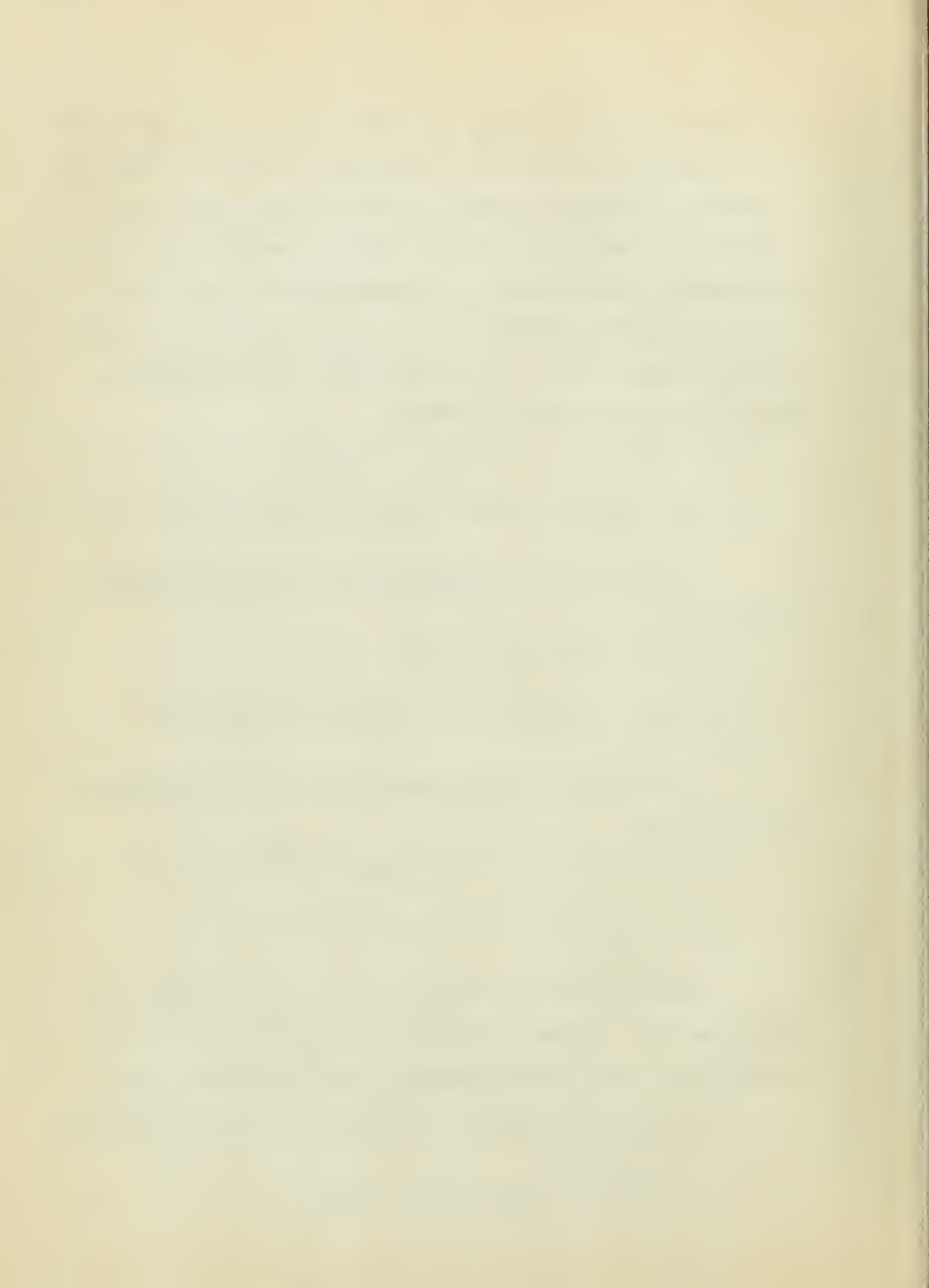

$$\lambda^2 + \left(\frac{.343}{h^*} + 1.72 - \frac{C_{m_{D\alpha}}^*}{h^*} \right) \lambda + \frac{12.69}{h^*} = 0$$

Comparing this equation with the general equation for a second order spring-mass-damper system:

$$\frac{d^2}{dt^2} + 2\zeta\omega_n \frac{d}{dt} + \omega_n^2 = 0$$

where ζ = damping ratio or ratio of actual damping to critical damping

ω_n = undamped natural angular frequency

the longitudinal short period motion of the airplane may be characterized by the parameters,

$$\omega = \sqrt{\frac{12.69}{h^*}} \quad \zeta = \left(\frac{1}{2\omega} \right) \left(\frac{.343}{h^*} + 1.72 - \frac{C_{m_{D\alpha}}^*}{h^*} \right)$$

From the above two relations,

$$-C_{m_{D\alpha}}^* = h^* (2\zeta\omega - 1.72) - .343$$

Figure 6 is a plot of h^* as abscissa versus $(-C_{m_{D\alpha}}^*)$ as ordinate on which are drawn lines of constant ζ and constant ω . This plot was used as a basis for determining changes in h^* and $C_{m_{D\alpha}}^*$ which yielded the desired variations in ζ and ω . Analog computer settings required to produce the selected combinations of damping ratio and frequency of longitudinal oscillation are tabulated in Table I.

Figures 8 through 13 represent the transient response, with selected combinations of frequency and damping, to a three-second input step function. This step function, graphed in Fig. 7, represents movement of the elevator control aft one-half inch for three seconds followed by return to the neutral position.

III. Calibration of Equipment and Conduct of Tests.

Proper calibration and operation of the telemeter system is prescribed in the instruction book on the system and will not be detailed here, except to note that the strength of the transmitted telemeter signal was somewhat critical. When this signal strength dropped below the threshold value of seven microvolts at the telemeter receiver, the magnetic tape record was invalidated.

In order to establish on the magnetic tape record a voltage representing zero noise and zero tracking error, each test in the flight simulator was preceded by a "zero" transmission of thirty seconds to one minute during which the random noise generator was turned off, the target pip centered on the horizon line and cross-hairs, and the test pilot's hands were off the centered control wheel. At the commencement of the test the pilot, wearing goggles with blue lenses behind an amber windshield to render invisible to him anything outside the cockpit (effectively simulating an instrument flight situation), took the controls. The noise generator was turned on and the test pilot attempted to track the moving target pip, keeping his cross-hairs centered on the pip as much of the time as possible. Tests normally ran for a period of five minutes, with a two minute period of the test record subsequently selected for evaluation. Once in the cockpit of the simulator, the test pilot would make from one to six test runs in succession with intervals between the runs sufficient for making changes in the analog computer circuit to simulate different airplane stability characteristics. For all test runs, the pilot was required to wear a parachute harness and crash helmet such as are used in fighter type aircraft. After each test run, the pilot's comments were recorded

regarding the difficulty of tracking, changes in his tracking technique since earlier runs, equipment malfunctions and distracting influences if any.

Each of the five pilots used was tested with seven different combinations of longitudinal damping and period of oscillation. Two of the five pilots were subsequently tested in nine other configurations of longitudinal damping and period.

IV. Data Reduction.

Each test record was first played back from the Ampex tape recorder through the telemeter translator unit into a recording oscillograph. The graphic records obtained on either a Brush or a Sanborn recording oscillograph were then examined for continuity and signal level. A two-minute portion of each record was selected which contained a minimum amount of telemeter signal dropout, recording malfunction, and excessive signal beyond the limits of the flight simulator. Initially, data was reduced by re-recording this two-minute portion of the test on the Crestwood portable magnetic tape recorder in two parts. First the telemeter channel selector was patched for output of X noise and X error, and these two components of the test recorded. Then the channel selector was patched for output of Y noise and Y error, and the process repeated. In this manner, synchronization was obtained between noise and error along each coordinate. All recording on the Crestwood was done at the optimum setting of the "record volume" control; no concern was given to the relative volumes of the two signals recorded simultaneously, since their signal levels were to be adjusted when playing back. Before each pair of test quantities was recorded on the Crestwood, a 30-second maximum signal, generated in the telemeter installation, was recorded

followed by the zero signal transmitted from the flight simulator in the test run. These signals were utilized in playing back the test records into the analog computer reducing circuits to equalize maximum signal levels on the two channels at five volts and to bias both circuits to zero for zero input. The five volt level, representing a twenty to one step-down of the original signal, was selected to stay within the experimentally established linear range of the Crestwood preamplifiers. Signal voltage from the telemeter translator varied from zero to negative 100 volts, these voltages representing a maximum displacement in either direction. The zero signal input recorded at the beginning of each test was represented at the telemeter translator by an output of approximately negative 50 volts. When the test records were played back from the Crestwood, into the analog computer reducing circuits, the gain controls were adjusted to produce a zero to negative five volt signal variation, with the zero signal input represented by approximately negative two and one-half volts.

The zero input signal varied slightly from day to day and from test run to test run. In the first stage of the data reducing circuit, a means was provided for producing any bias voltage required to yield zero voltage in the remainder of the circuit for the individual "zero signal" being put in. During the thirty-second zero signal input, the output of the first stage of the reducing circuit was observed for each channel and the bias voltages adjusted for zero output. This adjustment was very critical, since the zero input signal contained a very small sine wave caused by the sampling mechanism of the telemeter. Setting the bias voltage often required the repetition of the zero input signal several times to make sure that the bias voltage did not produce

an error larger than plus or minus two percent of the full signal.

After completion of all of the test runs, but before reduction of the test data, the analog computer and telemeter receiver installation were relocated adjacent to one another. With this arrangement, the Crestwood portable recorder was no longer required. The reducing circuits were altered accordingly to accommodate the zero to negative 100 volts output of the telemeter translators, with the bias level changing to approximately 50 volts instead of two and one-half. A by-product of this more convenient arrangement was the elimination of the possibility of error in setting the gain of the Crestwood amplifiers.

All data as finally used was reduced with the input to the analog computer reducing circuit coming directly from the Ampex recorder via the telemeter translator section.

The gain in the first stage of the analog computer reducing circuit was set to produce plus or minus 50 volts output from the first stage. It was initially decided to square each input quantity, both to obviate the cancellation of plus and minus quantities and also to facilitate determination of resultant noise and error after integration using the Pythagorean Theorem. Conversion of test records to voltages of one sign only made more convenient the squaring of the displacement signals. Through the use of diodes, the input signal was rectified in the second stage of the analog computer reducing circuit. A small bias voltage was required in the second stage to assure proper conduction and cutoff of each diode as the input signal changed polarity. The error in the second stage was less than one-half of one percent of maximum signal. The second stage gain was set to yield a maximum signal output of 10 volts.



The method selected for squaring the input signal was that of synthesizing a function generator, the output of which is a linearized parabola of four segments which approximates the function, $y = x^2$, with a maximum error of one percent of full scale voltage, or one volt. The squaring circuit output and the true parabola are compared in Fig. 15. The output of each of the two squaring circuits is then integrated. The voltage at the output of the integrator at the end of each two-minute test represents the squared input quantity integrated over a two-minute period. This voltage, V , may be considered to have the units volts²-seconds, and represents an average error over the test run of $\sqrt{8.5 V}$ mils.

In order to provide precise control over starting and stopping of the analog computer, a double pole off-on toggle switch was connected between squaring circuit output and integrator input of each circuit, without crossing the circuits, so that both were turned on and off simultaneously. Two minute test periods were timed with an electric darkroom timer equipped with a very loud buzzer.

The results for the tests conducted are tabulated according to test pilot in Tables II through VI. The test run number indicates the total number of simulator flights the pilot had made at the time of the test noted. Many test runs were eliminated from the tables because of some type of operational difficulty. Test runs omitted did contribute to the pilot's experience in the flight simulator.



RESULTS AND DISCUSSION

Evaluation of the radar tracking performance of any designated pilot and airplane longitudinal stability configuration can be accomplished in several ways. One method consists of measuring the time on target, or the time interval during which the tracking error is less than an arbitrarily designated level. Another scheme involves measuring error continuously and integrating the error over a selected time interval to permit determination of a mean error. In either of these methods the error considered could be total resultant error, or only the lateral or longitudinal component error. A reference for comparison might be selected accordingly as total resultant noise or only the X or Y component noise.

Original plans called for presentation of the data obtained in this investigation as the ratio of root mean square tracking error to root mean square noise versus change in longitudinal stability parameter. As the tests progressed and data accumulated, however, it became apparent that the amount of noise had little or no effect upon the tracking error. A more significant quantity was then thought to be the rate of change of noise level. Examination of the time history records revealed that even this quantity is not in itself the only significant one. Another error was introduced when the noise changed direction or velocity. Realization of this prompted the decision to present the data not as a ratio but rather as root mean square error versus the longitudinal stability parameter. Since the noise is random, it was assumed that differences in rate of change of noise and changes of velocity and direction between various test runs were insignificant. To verify this assumption, each test pilot

was required to make two test runs with no change in the aircraft stability configuration. Test results were found to be repeatable within twenty percent. Further justification for the assumption was found in the determination that errors were independent of noise level.

Another uncertainty concerning data presentation was the significance of error in the X direction; i.e., whether total error or error in the Y direction only should be the dependent variable when comparing the various longitudinal stability configurations. Test records showed that the error in the X direction was generally more than twice the error in the Y direction. As a result of this, variations in X-error for the same longitudinal stability configuration-pilot combination, although a reasonably small fraction of the total X-error, were of such a magnitude as to represent a large percentage of the total Y-error.

In view of the above, the decision was made to present test data as the integrated squared error in the Y direction only, versus the change in longitudinal stability parameters.

For each test, two minutes of the run were taken, and had the same total gain from magnetic tape through the analog computer as all other test records. To convert the integral of squared error in volts to root-mean-square error in inches would require division of the voltage by $\sqrt{512}$ and extraction of the square root. Conversion of the integral of squared error in volts to root-mean-square error in mils requires multiplication of the voltage by eight and one-half and extraction of the square root.

Test run numbers appearing in the first columns of Tables II through VI indicate the ordinal number of that run in the particular

pilot's total experience with the flight simulator. As noted previously, many runs were eliminated because of difficulties encountered. While these runs were unproductive of usable data, they did serve to increase the pilot's experience in the flight simulator.

Y error is plotted versus damping ratio in Fig. 17 for each of the five pilots tested, with the airplane longitudinal natural frequency held constant at 3.56 radians per second. It can be seen that for damping ratio, ζ , greater than 0.15 the error does not vary significantly with a change in damping ratio, while for a damping ratio less than 0.15 the errors become rapidly larger as the damping ratio decreases.

The duplicated test runs mentioned above for each pilot were made for the normal "Navion" longitudinal stability configuration ($\zeta = 0.727$; $\omega = 3.56$). Comparing the pairs of test results, agreement within twenty percent was found for each pilot. Upon this basis the hopeful assumption was made that all test results obtained might be taken as representative of a larger number of runs made with the same combinations of pilot and longitudinal stability characteristics, within a scatter of twenty percent. This assumption actually represents a policy decision to use the time available to obtain test data for more different longitudinal stability configurations and accept the probable sacrifice in accuracy, in the belief that the test results taken as a whole would be more meaningful in this way.

On the constant frequency plot (Fig. 17) of Y-error versus damping ratio, the test results for all five pilots can be represented within twenty percent by a single line except at damping ratios of 0.727 and 0.079. It is believed that the number of data points obtained



for the five pilots is insufficient to warrant any conclusion from this plot. This dearth of data is improved considerably by plotting the Y-error versus time to damp to one-half amplitude, (Fig. 20) where time to damp to one-half amplitude is equal to the quantity, $(.693/g\omega)$.

Extending the constant frequency plot (Fig. 17) to include variations in frequency of oscillation, results for two of the five pilots are presented in Figs. 18 and 19. Time available was insufficient for all five pilots to make tests with damping ratio and frequency both varying, but since the results for all five pilots on the constant frequency plot are similar, it is believed that data for the two pilots tested with both damping ratio and frequency of oscillation varying is representative. Referring to Figs. 18 and 19, the curves of Y-error versus damping ratio for selected natural frequencies of longitudinal oscillation have the same general shape, dipping in the center at some best range of damping ratio and indicating markedly larger errors for very low values of damping ratio.

Y-error versus time to damp to one-half amplitude is presented in Fig. 20 to take advantage of the greater number of test points available with this scheme, and to reduce the doubt arising from the scatter on the constant frequency plot (Fig. 17) at a damping ratio of 0.727. Correlating the indication in Figs. 18 and 19 of some best range of damping ratios, Fig. 20 shows that the error level is affected very little with the time to damp to one-half amplitude less than 1.386 seconds, but that error increases radically for time to damp to one-half amplitude greater than 1.386 seconds.

Y-error versus frequency of longitudinal oscillation for a constant damping ratio of 0.727 is presented in Fig. 21. For this

value of damping ratio, frequency variation between 1.52 and 4.25 radians per second is found to have no effect upon the error level.

Y-error versus frequency of oscillation for values of damping ratio other than 0.727 is presented for two of the five pilots in Figs. 22 and 23. Figure 22 shows the results to be inconclusive for pilot "D"; Fig. 23 for pilot "E" indicates that within the range shown, variation in longitudinal natural frequency of oscillation has no effect upon Y-error for damping ratios of 0.266 and 1.0. For a damping ratio of 0.079 the error increased as frequency of oscillation decreased.

Inasmuch as the results shown in Figs. 22 and 23 do not corroborate each other, Y-error was plotted versus the damped natural frequency of longitudinal oscillation, $\omega\sqrt{1-\zeta^2}$ in Fig. 24 to ascertain whether any further indications would be developed thereby. Disregarding the points representing stability configurations with very low damping ratios ($\zeta = .079$), the plot of Y-error versus the damped frequency, $\omega\sqrt{1-\zeta^2}$, is represented by one curve with very little scatter of points. Figure 24 indicates that changing the natural frequency between 1.52 and 4.25 radians per second had negligible effect upon Y-error.

In evaluating the test results described above, it is noteworthy that the test pilots involved were not normally allowed a familiarization run for each change of longitudinal stability configuration, but became acquainted with the aircraft response during the test. This procedure was necessitated by the ambitious test program and the limited time available. Rather than invest time in training the pilots with familiarization runs, it was considered more productive to proceed with the test program to encompass as many different stability configurations as possible. A factor in this decision was the fact that all of the

pilots had previous experience in flying several different types of naval combat aircraft. When the longitudinal stability of the flight simulator was changed from one configuration to another, the first indication to the test pilot of the new response came subsequent to the initial stick movement. If the pilot had difficulty in getting accustomed to the response, this was usually overcome in the first thirty seconds of the test. In these cases, the two-minute test interval to be evaluated was commenced after the pilot had become somewhat acquainted with the new simulator response. There is little doubt that experience would decrease the actual error, but it is felt that the results obtained accurately indicate the trend of the errors when damping and frequency are varied.

The test results obtained in this investigation aroused interest in several modifications which might profitably be made in the test program when and if further work is planned in this direction. The effect upon both X and Y errors produced by changes in the lateral stability parameters of the test airplane should be of great interest. All of the pilots used as test subjects in this investigation felt that their tracking performance was in some way affected by the rate of target pip motion in azimuth. It is possible that investigation of the lateral and longitudinal cases simultaneously would indicate an optimum relation between the rates of longitudinal and lateral oscillations of the test aircraft.

In the gathering of the data reported here, no distractions were presented to the test pilot such as might occur in flight with variations in engine performance, radio transmissions, operation of armament switches and so on.

There was no attempt to correlate stick force and change of

stability parameter with each other, nor was there any correlation between the change of stability parameter and the forces exerted on the pilot in actual flight. Low damping ratios were accompanied by excessive control movement, which would have produced "g" forces of distracting or perhaps intolerable magnitude in flight.

It was not the purpose of this investigation to determine the effects of the factors noted above on the pilot's tracking error, but they should be considered in any attempt to correlate these results with flight test results. It is felt that the major parameters affecting tracking error were investigated for the longitudinal case, and that significant trends were established. Other parameters may affect the magnitude of total error, but would not alter the general shapes of the curves presented here.

The variation in the final data caused by the use of the Crestwood portable tape recorder and the associated circuitry was insignificant. The use of the Crestwood recorder is very time-consuming in that only two channels can be recorded at a time. In this case, four quantities were desired, which necessitated the playing back of each test run twice to get it on "portable tape" and twice again to get the information into the reducing circuits.

CONCLUSIONS AND RECOMMENDATIONS

The method used in this investigation has been demonstrated to produce reasonable and apparently valid results which are repeatable within an experimental error of approximately twenty percent. In consideration of the problem involved here and the difficulty of obtaining actual flight test data for significant changes in airplane longitudinal stability, the test method used in this investigation is judged worthy of further development and use.

The use of a portable tape recorder, when necessary in the handling of test data, does not impair the results in any way. The recorder may be used as an amplifier in the reducing circuit within the linear range of the recorder preamplifiers.

Based upon the test results reported herein, the time to damp to one-half amplitude for the longitudinal oscillation should be less than 1.39 seconds, and the damping ratio should be greater than 0.10 for an airplane to be considered satisfactory for tracking an aerial target. The effect of variation in the airplane's longitudinal natural frequency of oscillation upon radar tracking error is insignificant over the frequency range of 1.78 to 4.25 radians per second.

The mean radar tracking error with a designated longitudinal stability configuration is not a function of the amplitude of the noise signal used to simulate target motion, nor does this error vary widely among pilots of similar flight experience.

It is recommended that further study be made in the correlation of pilot-airplane performance with changes in the stability parameters of the airplanes. Specifically, the investigation reported here

should be amplified to include damping ratios in the range of 0.45 and natural frequencies beyond 4.25 radians per second in order to provide greater coverage. Ideally, each pilot should make test runs in which both the damping ratio and the natural frequency are varied, and each pilot should make multiple runs for each configuration tested.

The lateral case should be investigated as has been done here for the longitudinal case, or preferably, in conjunction with variations in longitudinal parameters. The possible existence of an optimum relation between longitudinal and lateral oscillation frequencies should be investigated.

It is recommended that tests be conducted with the addition of some distracting influence, such as radio transmissions which must be answered or warning lights which require actuation of some lever, to determine whether or not this influence would alter the relationships between tracking error and airplane stability parameters.

Inasmuch as the method used in this investigation for evaluating the tracking performance is not known to be optimum, it is recommended that other criteria be evaluated, such as the use of time on target within a selected small error tolerance.

TABLE I
ANALOG COMPUTER SETTINGS FOR VARIOUS LONGITUDINAL
STABILITY CONFIGURATIONS

ξ	ω	h^*	C_{mp}^*	R_4 Meg Ω	R_5 Meg Ω	R_6 Meg Ω	R_7 Meg Ω	R_8 Meg Ω	Pot (ii)
.727	3.56	1.0	-3.13	0.1	1.0	0.1	∞	1.0	.313
.266	3.56	1.0	+1.72	0.1	1.0	∞	1.0	1.0	.172
1.0	3.56	1.0	-5.06	0.1	1.0	0.1	∞	1.0	.506
.079	3.56	1.0	+1.501	0.1	1.0	∞	0.1	1.0	.150
.727	4.25	0.7	-2.76	.07	.7	0.1	∞	.7	.276
.727	2.52	2.0	-3.53	0.2	2.0	0.1	∞	2.0	.353
.727	1.78	4.0	-3.13	0.4	4.0	0.1	∞	4.0	.313
.266	4.25	0.7	-.053	.07	0.7	1.0	∞	0.7	.530
.079	4.25	0.7	+1.08	.07	0.7	∞	0.1	0.7	.108
1.0	4.25	0.7	-4.40	.07	0.7	0.1	∞	0.7	.440
.266	2.52	2.0	+1.10	0.2	2.0	∞	0.1	2.0	.110
.079	2.52	2.0	2.99	0.2	2.0	∞	0.1	2.0	.299
1.0	2.52	2.0	-6.30	0.2	2.0	0.1	∞	2.0	.630
.266	1.78	4.0	+3.43	0.4	4.0	∞	0.1	4.0	.343
.079	1.78	4.0	6.10	0.4	4.0	∞	0.1	4.0	.610
1.0	1.78	4.0	-7.02	0.4	4.0	0.1	∞	4.0	.702

TABLE II
TABLE OF RESULTS
PILOT A

TEST	ρ	β	$\int N_x^2 dt$ (VOLTS)	$\int e_x^2 dt$ (VOLTS)	$\int N_y^2 dt$ (VOLTS)	$\int e_y^2 dt$ (VOLTS)
8	.079	3.56	70.0	40.0	68.0	37.5
9	.266	3.56	46.0	46.5	44.5	16.0
10	1.0	3.56	63.5	35.0	42.0	18.0
11	.727	3.56	50.0	40.0	25.5	12.0
12	.727	1.78	68.0	40.0	41.5	22.0
13	.727	2.52	32.0	32.0	34.0	12.0
14	.727	4.25	32.0	36.0	46.0	13.0
17	.727	3.56	39.0	34.0	44.0	12.0



TABLE III
TABLE OF RESULTS
PILOT B

TEST	β	ω	$\int N_x^2 dt$ (VOLTS)	$\int e_x^2 dt$ (VOLTS)	$\int N_y^2 dt$ (VOLTS)	$\int e_y^2 dt$ (VOLTS)
4	1.0	3.56	42.0	28.5	38.0	14.0
5	.266	3.56	44.5	32.0	35.0	18.0
6	.079	3.56	45.0	39.0	32.0	43.0
9	.727	1.78	103.0	48.0	76.0	40.0
10	.727	2.52	54.0	60.0	42.0	19.0
11	.727	4.25	54.0	56.0	33.0	18.5
13	.727	3.56	39.0	32.0	52.0	13.0
14	.727	3.56	40.0	45.0	46.0	18.0

TABLE IV
TABLE OF RESULTS
PILOT C

TEST	ϕ	β	$\int N_x^2 dt$ (VOLTS)	$\int e_x^2 dt$ (VOLTS)	$\int N_y^2 dt$ (VOLTS)	$\int e_y^2 dt$ (VOLTS)
8	.727	1.78	470	590	42.0	50.0
9	.727	2.52	520	54.0	56.0	49.0
11	1.0	3.56	55.0	44.5	51.0	32.0
12	.268	3.56	39.0	32.0	40.5	19.0
13	.079	3.56	36.0	44.0	65.0	51.5
14	.727	4.25	56.0	35.0	46.0	23.0
15	.727	3.56	49.0	42.0	29.0	23.0
17	.727	3.56	1080	36.0	76.0	32.0

TABLE V
TABLE OF RESULTS
PILOT D

TEST	δ	β	$\int N_x^2 dt$ (VOLTS)	$\int e_x^2 dt$ (VOLTS)	$\int N_y^2 dt$ (VOLTS)	$\int e_y^2 dt$ (VOLTS)
10	.727	1.78	61.0	28.5	64.0	19.5
11	.727	2.52	68.0	35.0	28.0	12.0
12	.727	4.25	36.0	30.0	27.0	11.0
13	1.0	3.56	56.0	28.0	36.0	14.0
14	.266	3.56	44.0	33.5	40.0	15.0
15	.079	3.56	35.0	24.0	47.0	28.5
16	.727	3.56	52.0	27.0	55	26.5
17	.727	3.56	50.0	26.0	34.0	22.0
18	.079	2.52	36.0	42.0	30.0	56.5
19	.266	2.52	74.0	35.0	38.0	37.5
20	1.0	4.25	84.5	40.5	51.5	32.5
21	.079	4.25	47.5	43.0	41.0	40.0
22	.266	4.25	28.0	28.0	49.0	25.0
24	1.0	2.52	61.0	34.5	44.0	42.0
29	.266	1.78	57.0	30.5	46.0	26.0
30	.079	1.78	44.0	41.0	43.0	54.0
31	1.0	1.78	52.0	28.0	40.0	21.0

TABLE VI
TABLE OF RESULTS
PILOT E

TEST	ϕ	β	$\int N_x^2 dt$ (VOLTS)	$\int e_x^2 dt$ (VOLTS)	$\int N_y^2 dt$ (VOLTS)	$\int e_y^2 dt$ (VOLTS)
17	.079	3.56	50.0	40.0	49.0	21.0
18	.266	3.56	32.5	30.0	58.0	14.0
19	1.0	3.56	35.5	31.0	37.5	14.0
20	.727	4.25	50.0	33.0	35.0	10.0
21	.727	2.52	44.0	28.0	36.0	17.5
22	.727	1.78	38.0	24.0	42.0	14.0
23	.266	4.25	38.0	34.5	34.0	17.5
24	.079	4.25	49.0	31.0	54.0	16.0
25	1.0	4.25	46.5	38.0	28.0	11.0
26	.266	2.52	43.0	31.0	39.0	13.0
27	.079	2.52	72.0	44.0	37.0	26.0
28	1.0	2.52	50.0	27.0	65.0	20.0
29	1.0	1.78	40.0	37.0	32.0	20.0
30	.079	1.78	58.0	32.0	45.0	50.0
31	.266	1.78	45.5	35.0	46.5	22.5
32	.727	3.56	74.0	27.0	45.0	18.0
34	.727	3.56	58.0	43.0	66.0	20.0



Fig. 1. Airplane used in flight simulator showing cockpit, cowl-mounted radar scope and electronic random noise generator mounted behind seat.



Fig. 2. Cockpit of flight simulator showing radar scope face and test pilot at the controls.

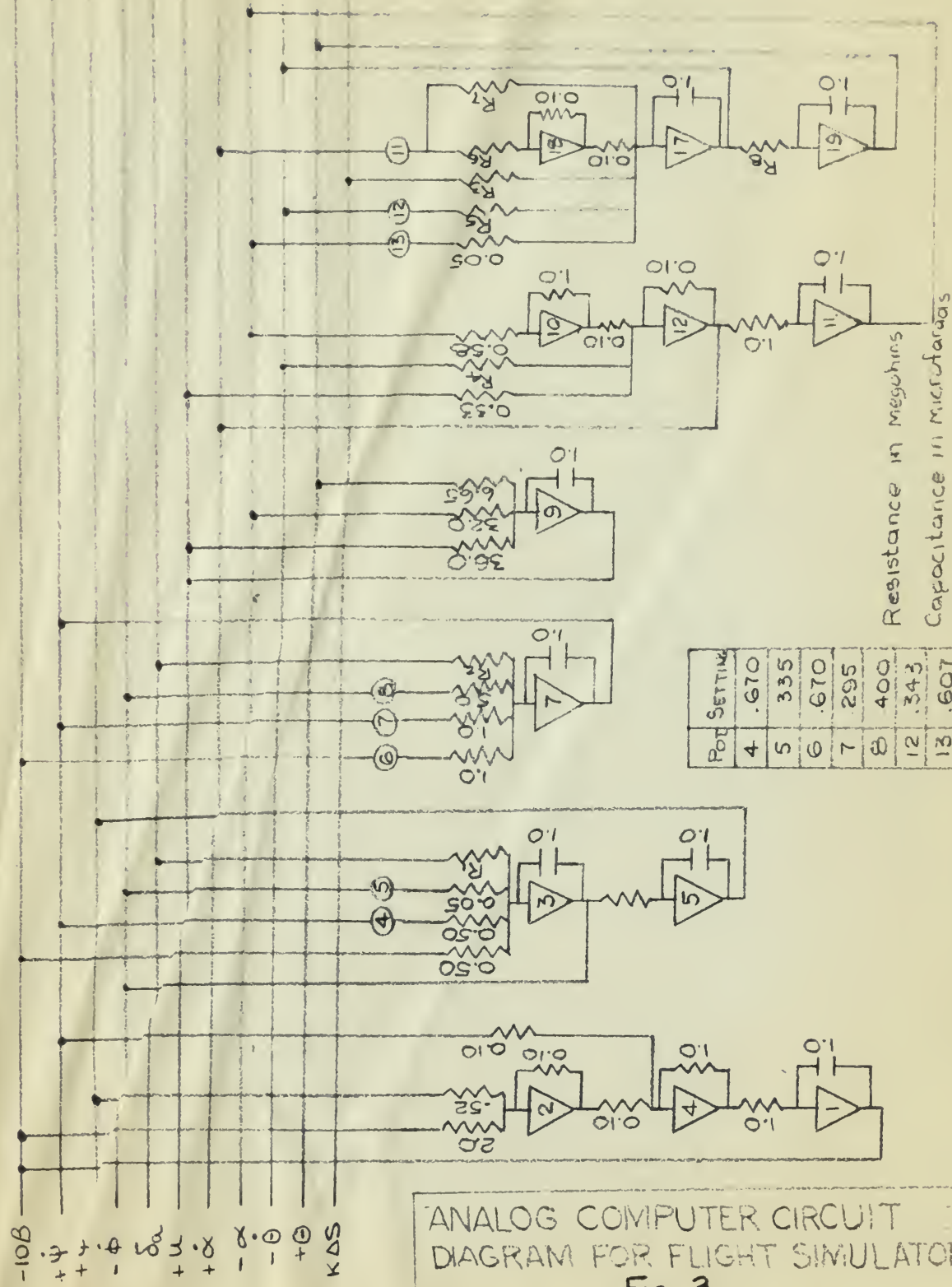

ANALOG COMPUTER CIRCUIT
DIAGRAM FOR FLIGHT SIMULATOR
FIG. 3

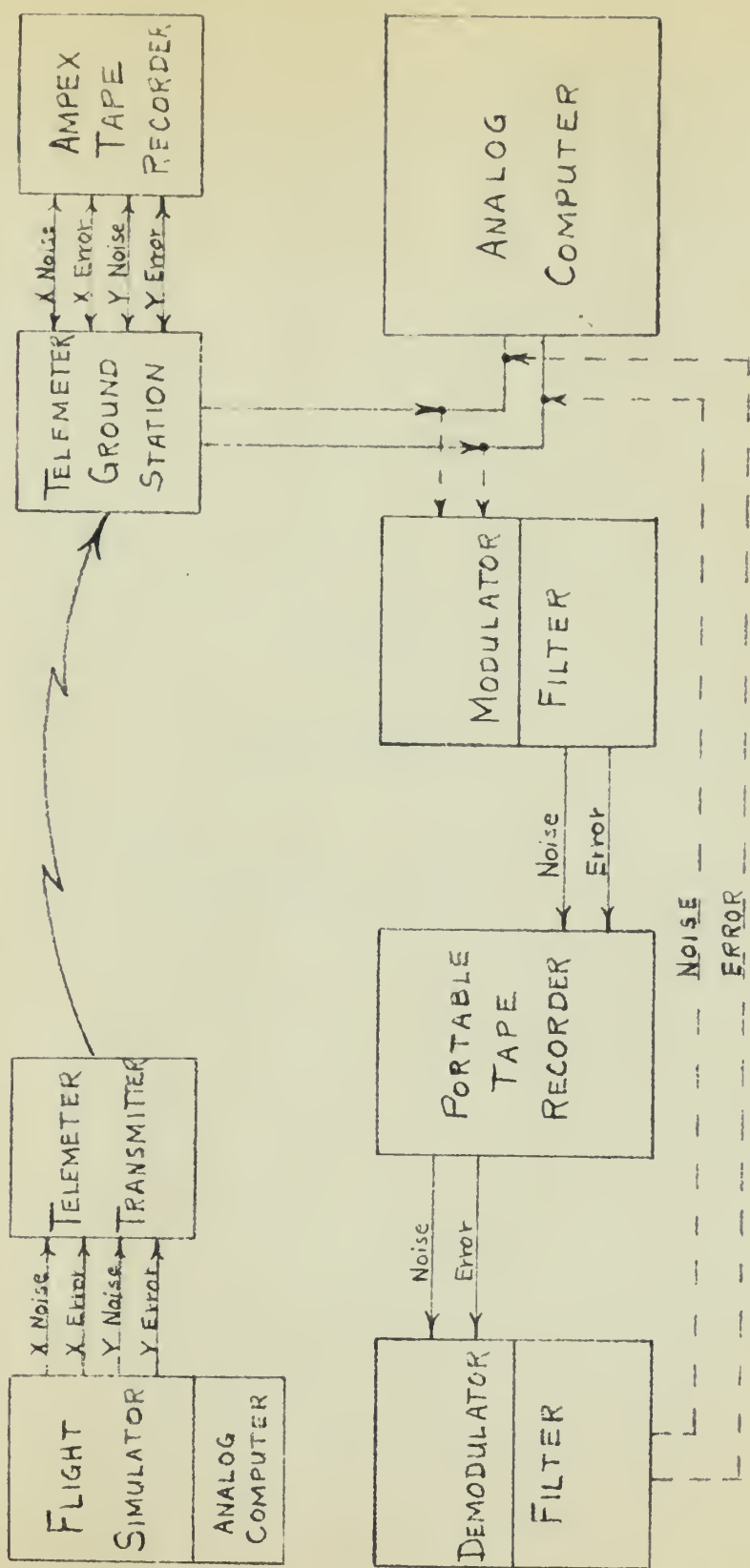

FIG. 4
 SIGNAL PATH TO ANALOG COMPUTER
 REDUCING CIRCUIT



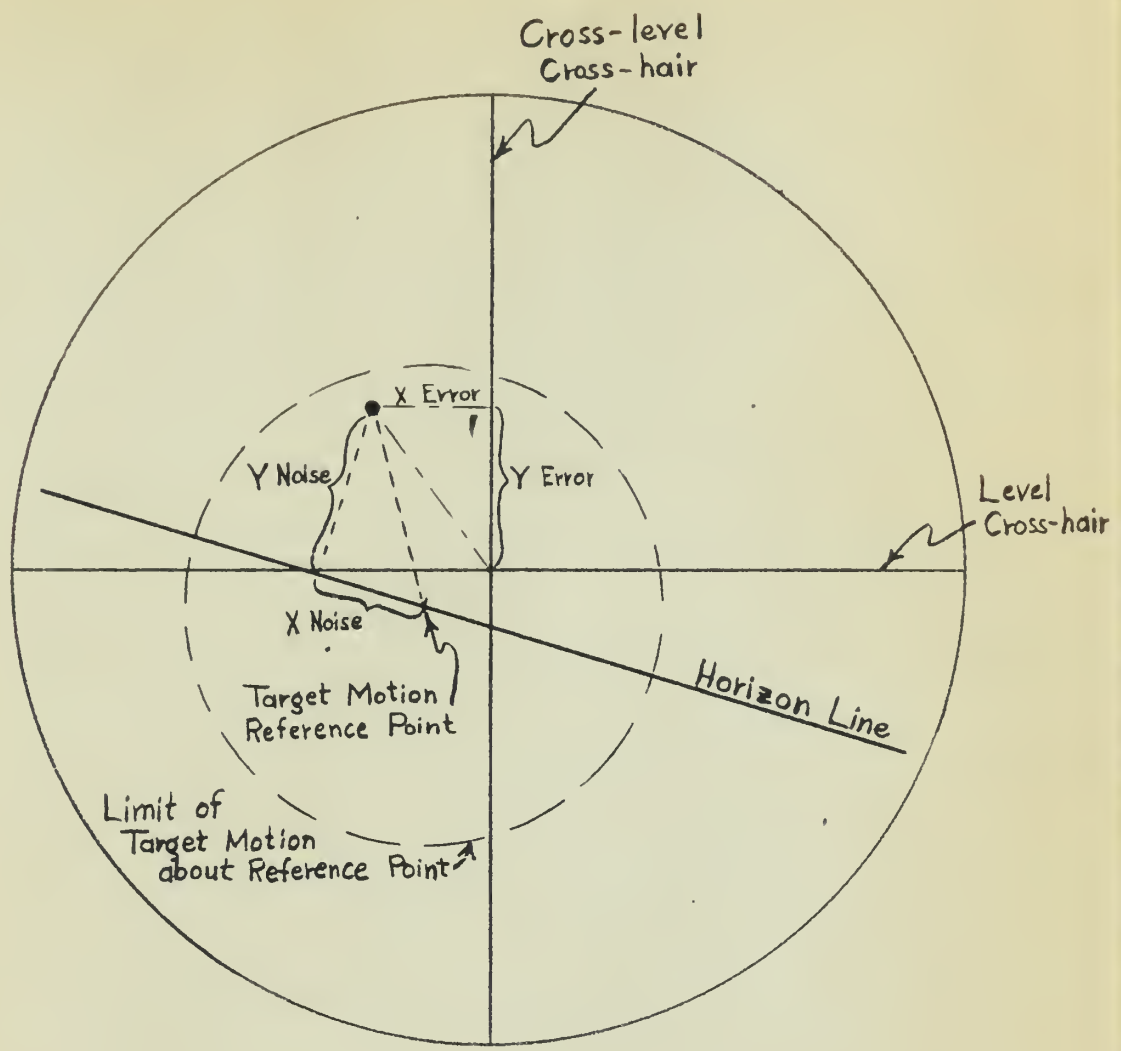
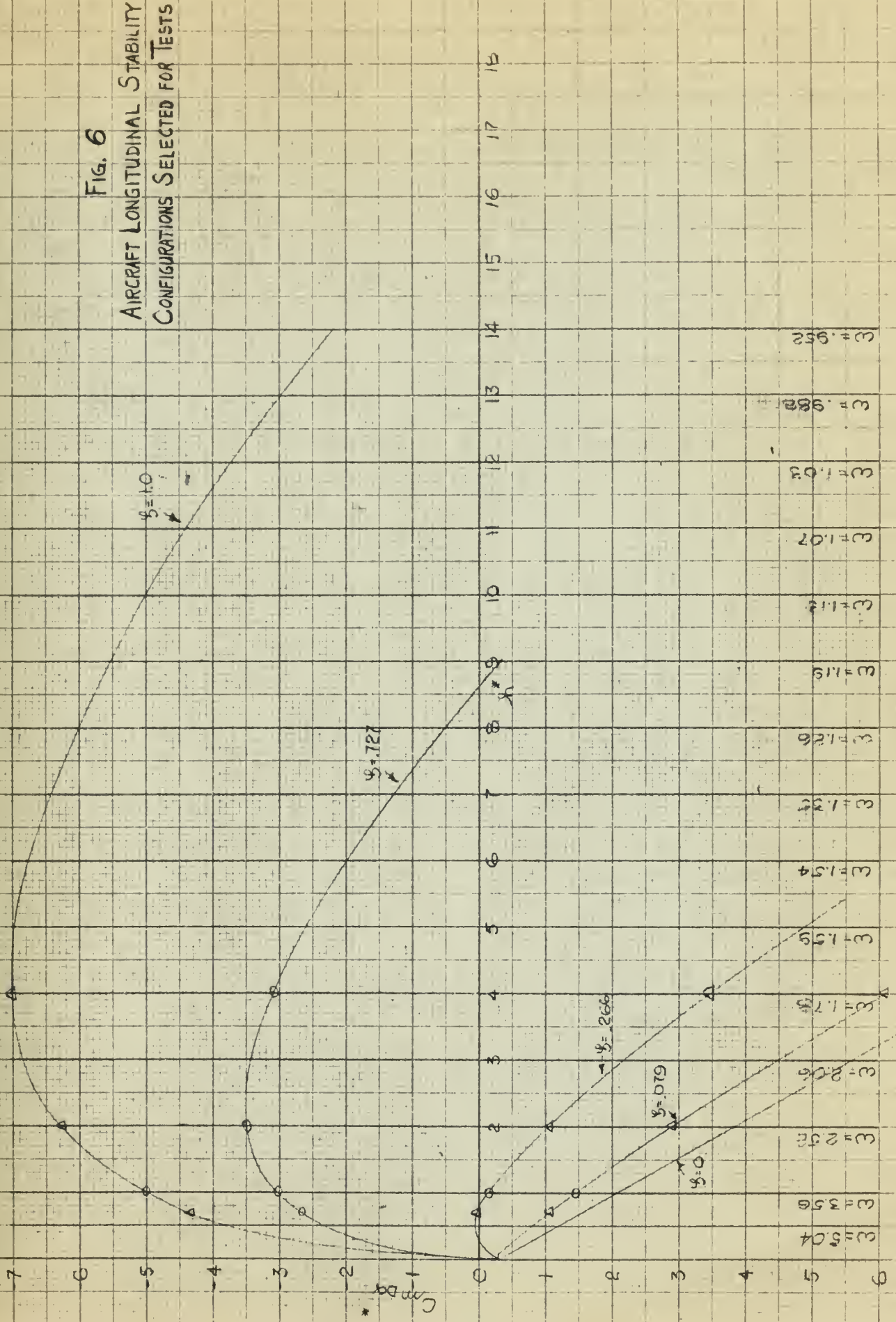

Fig. 5
Pilot's C-Scope Presentation



FIG. 6
 AIRCRAFT LONGITUDINAL STABILITY
 CONFIGURATIONS SELECTED FOR TESTS



* Cmδa*

CONTROL MOTION INPUT
FOR DETERMINING
LONGITUDINAL RESPONSE
OF FLIGHT SIMULATOR
FIG 7

CONTROL MOTION - $\Delta s - IN$

TIME - SEC

0.5
0.4
0.3
0.2
0.1

2

3

4

5

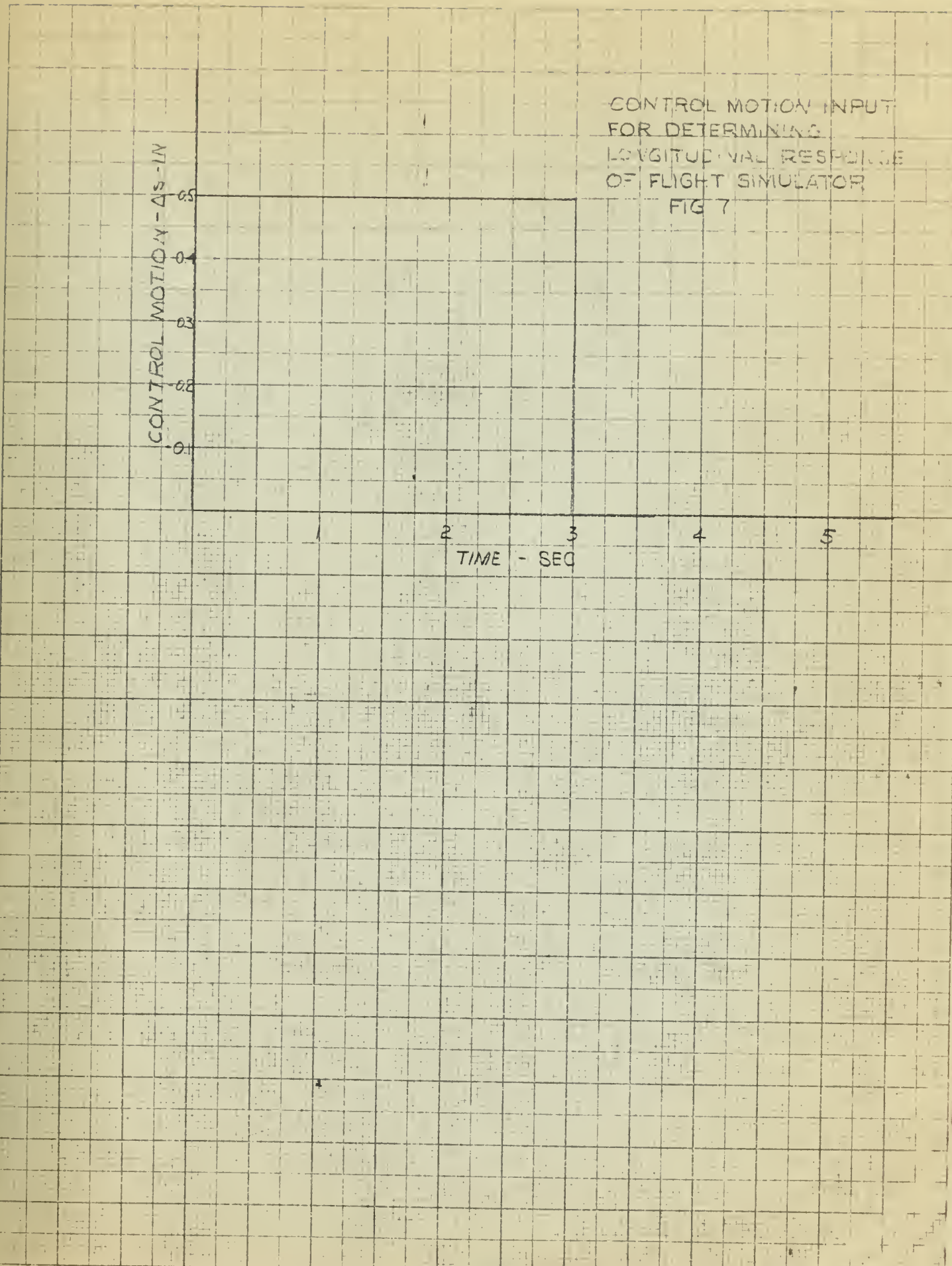

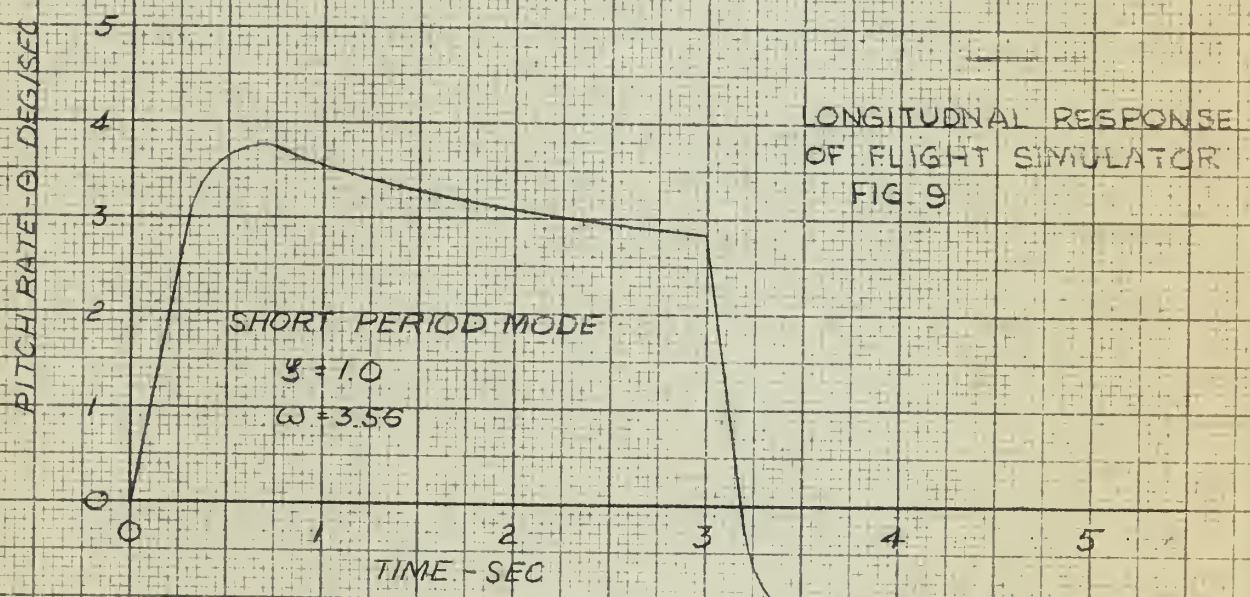
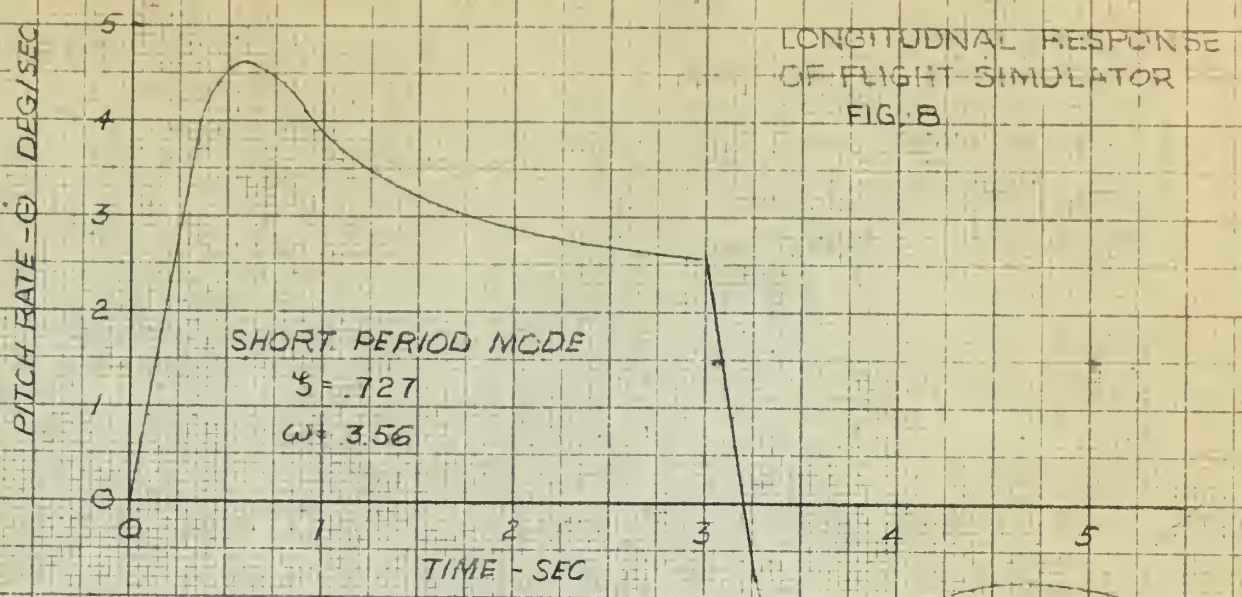

LONGITUDINAL RESPONSE
OF FLIGHT SIMULATOR
FIG. 10

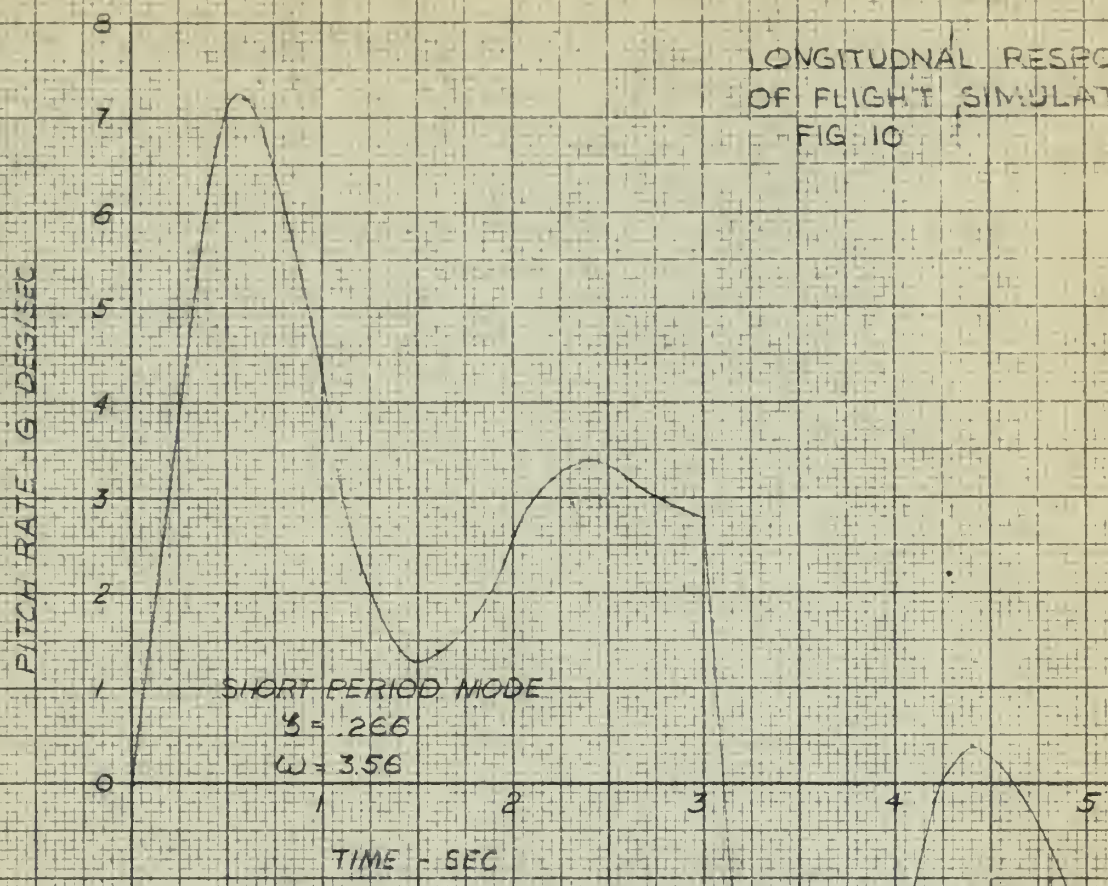

LONGITUDINAL RESPONSE
OF FLIGHT SIMULATOR
FIG 11

PITCH RATE - DEG/SEC

TIME - SEC

SHORT PERIOD MODE

$$\xi = .079$$

$$\omega = 3.56$$

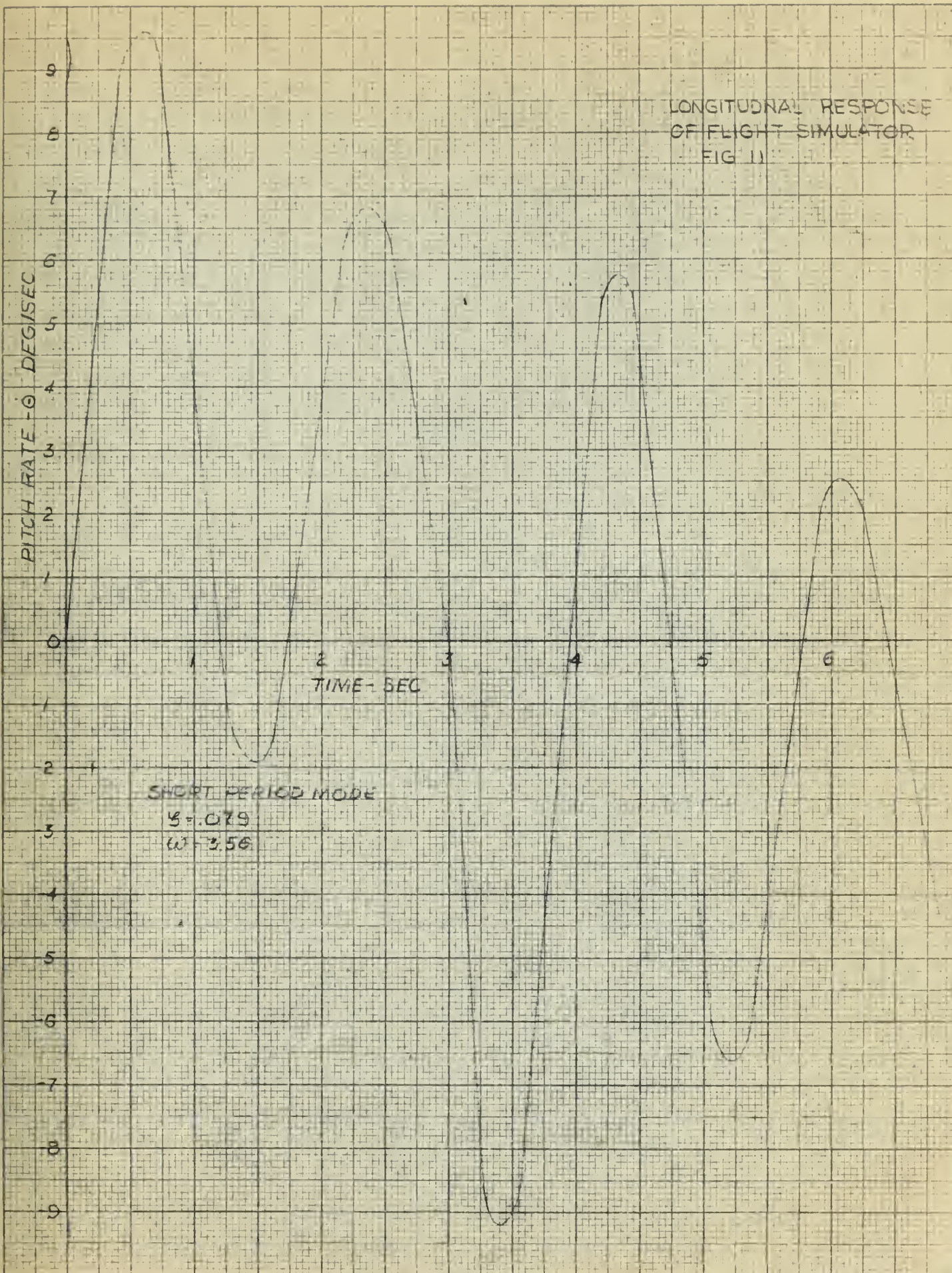

Pitch Rate, $\dot{\theta}$, Deg./Sec.

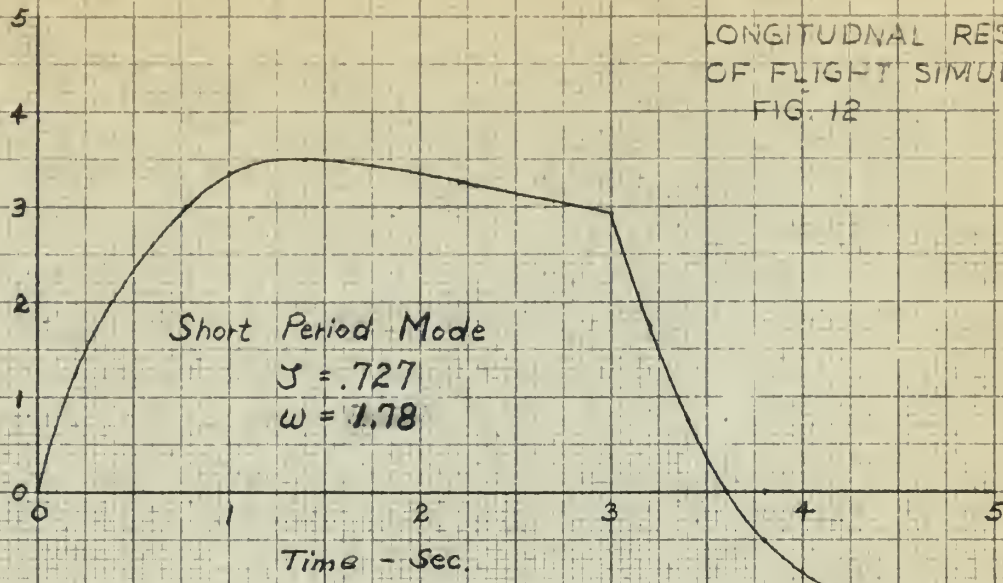

Pitch Rate, $\dot{\theta}$, Deg./Sec.

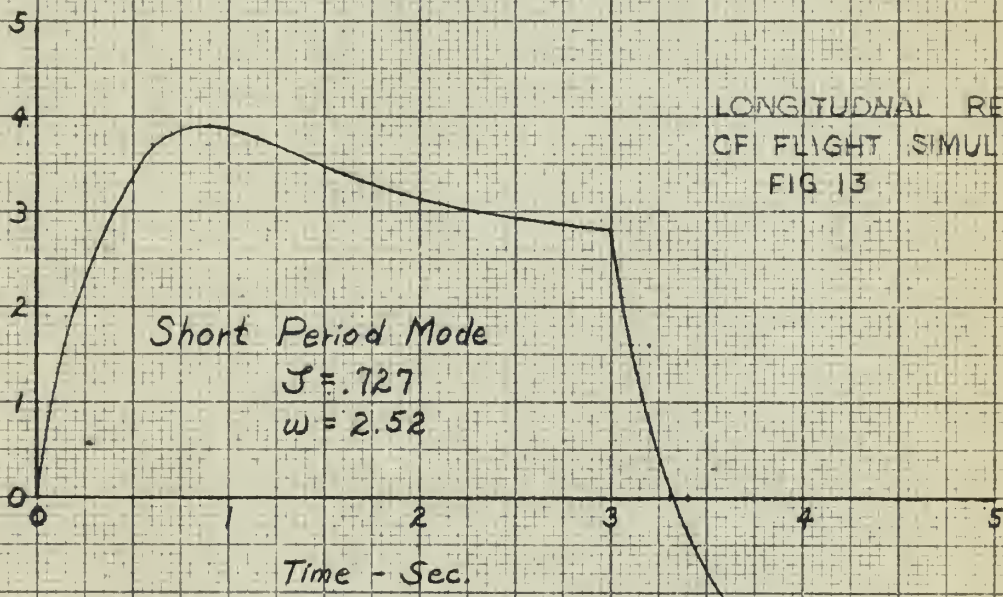



LONGITUDINAL RESPONSE
OF FLIGHT SIMULATOR
FIG 14

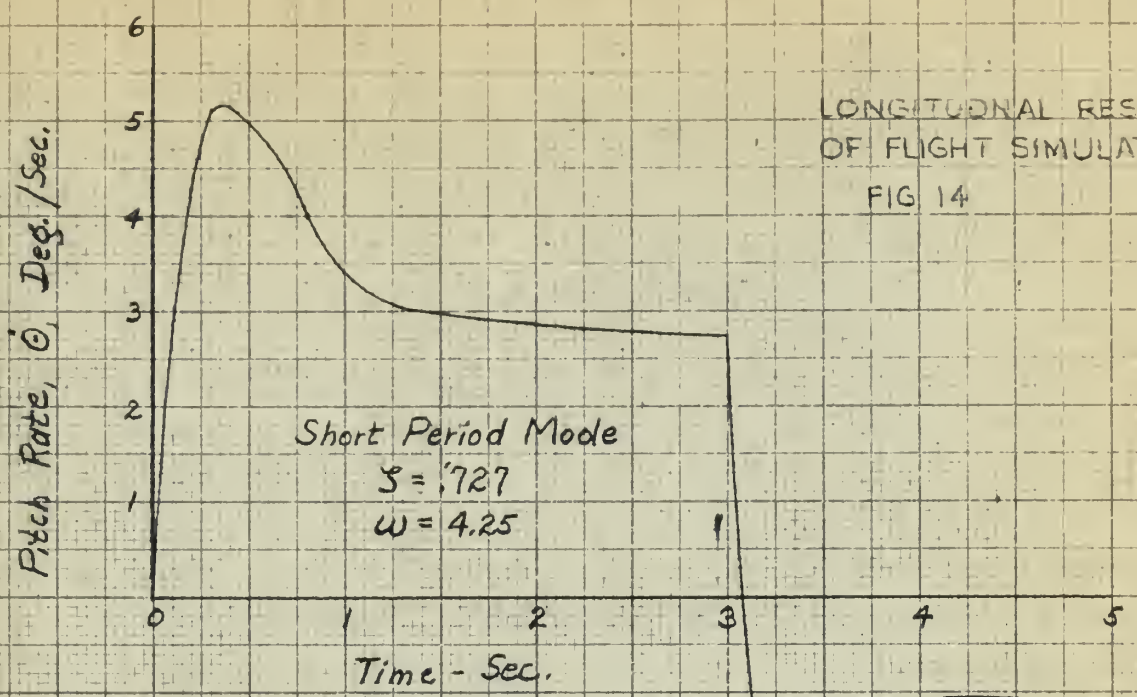

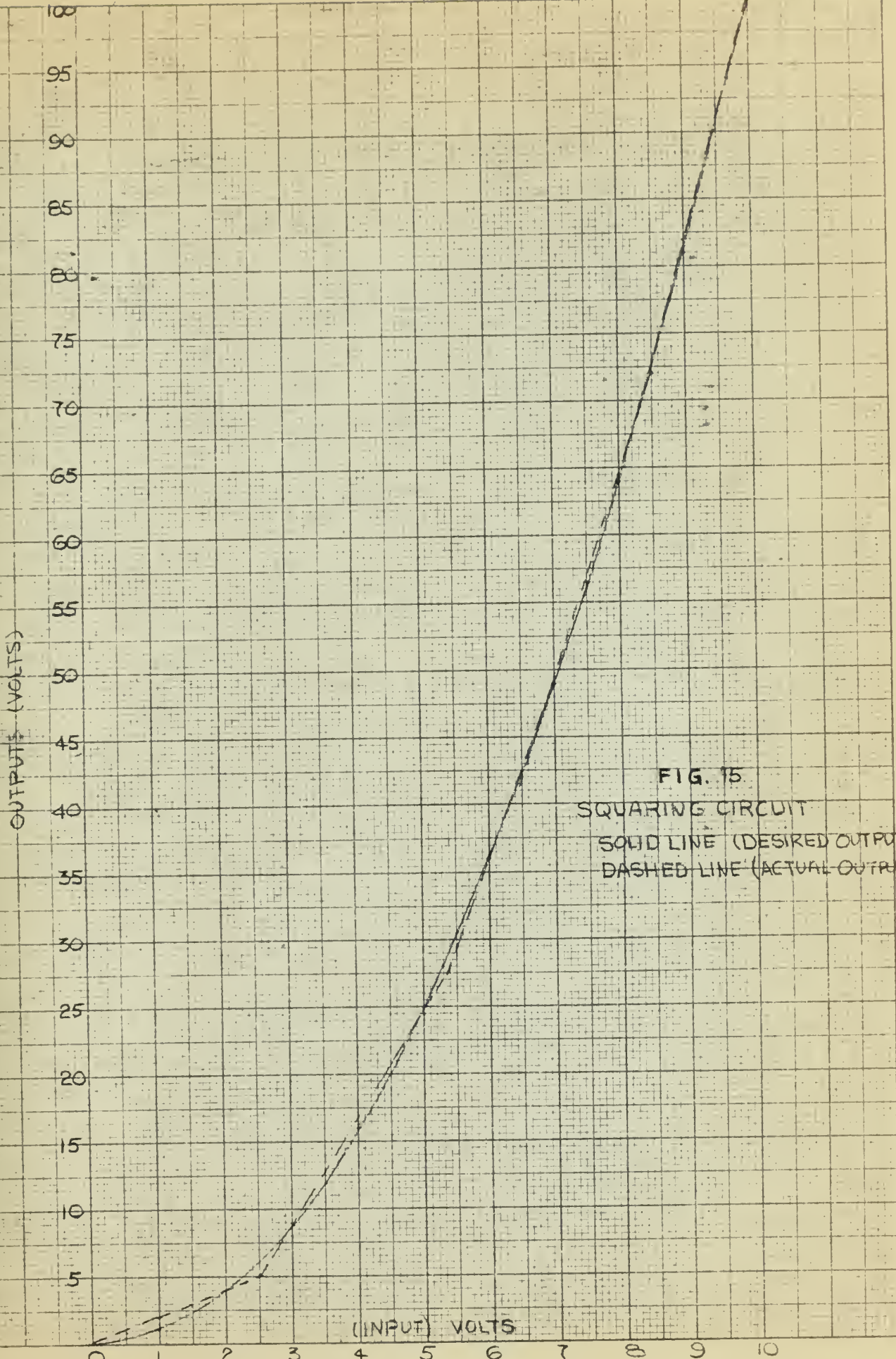
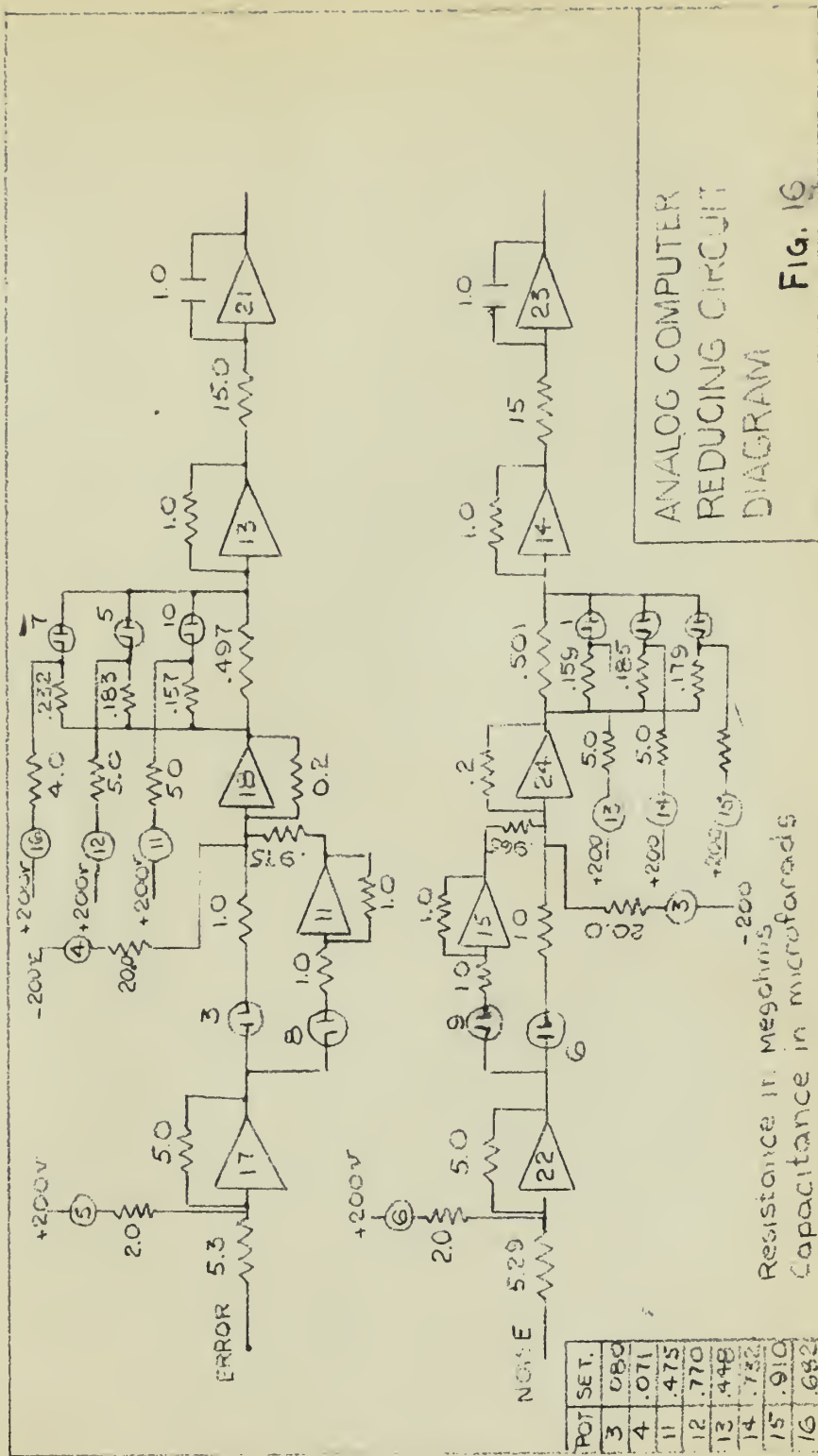

FIG. 15
SQUARING CIRCUIT
SOLID LINE (DESIRED OUTPUT)
DASHED LINE (ACTUAL OUTPUT)



ANALOG COMPUTER
REDUCING CIRCUIT
DIAGRAM

Fig. 16

Resistance in Megohms
Capacitance in microfarads

FIG 37

Y ERROR VERSUS δ AT CONSTANT ω

$\omega = 3.56$

- PILOT A ○
- PILOT B □
- PILOT C ▽
- PILOT D ▲
- PILOT E ◇

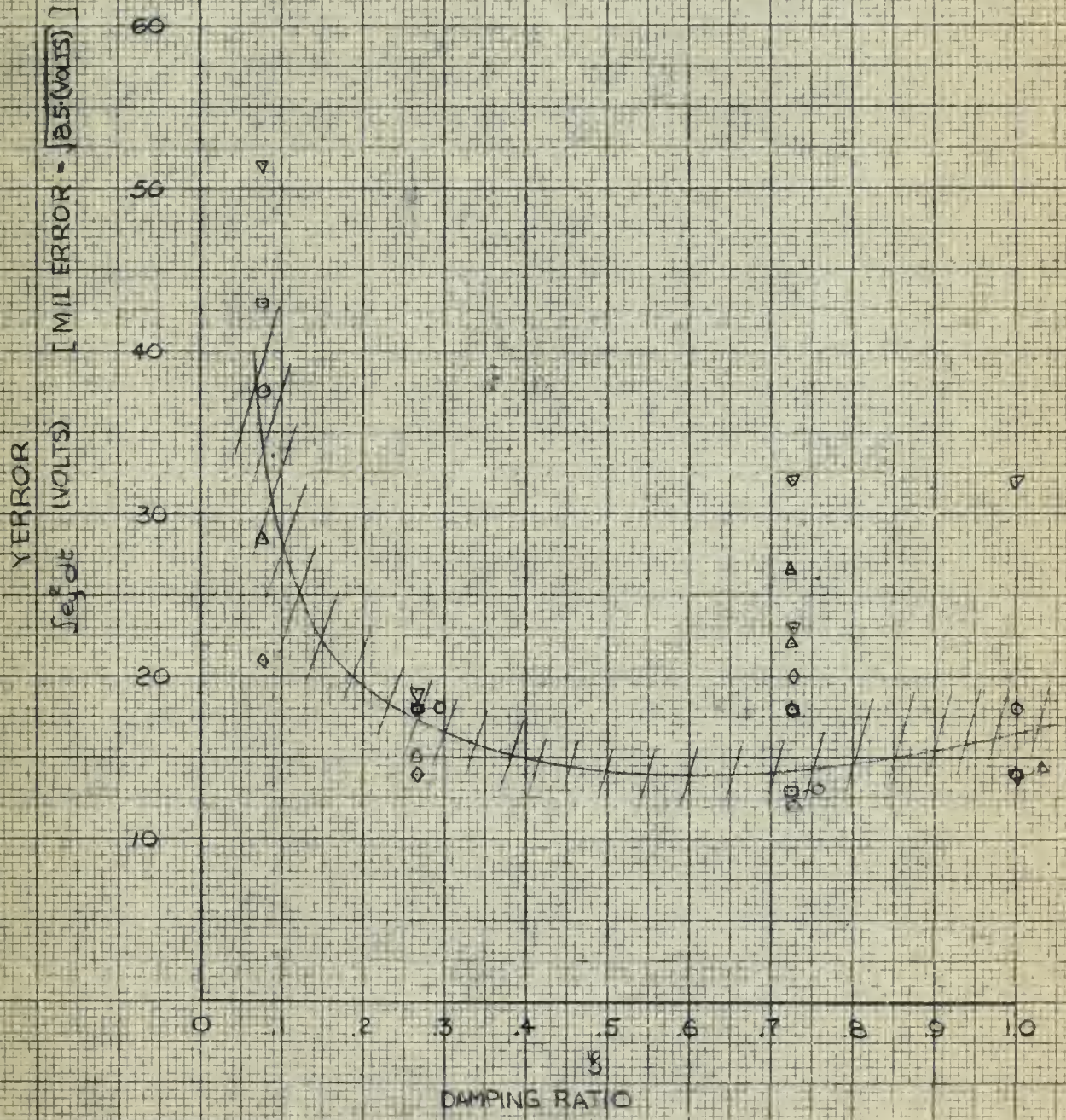

FIG 18
Y ERROR VERSUS ζ FOR PLOT D

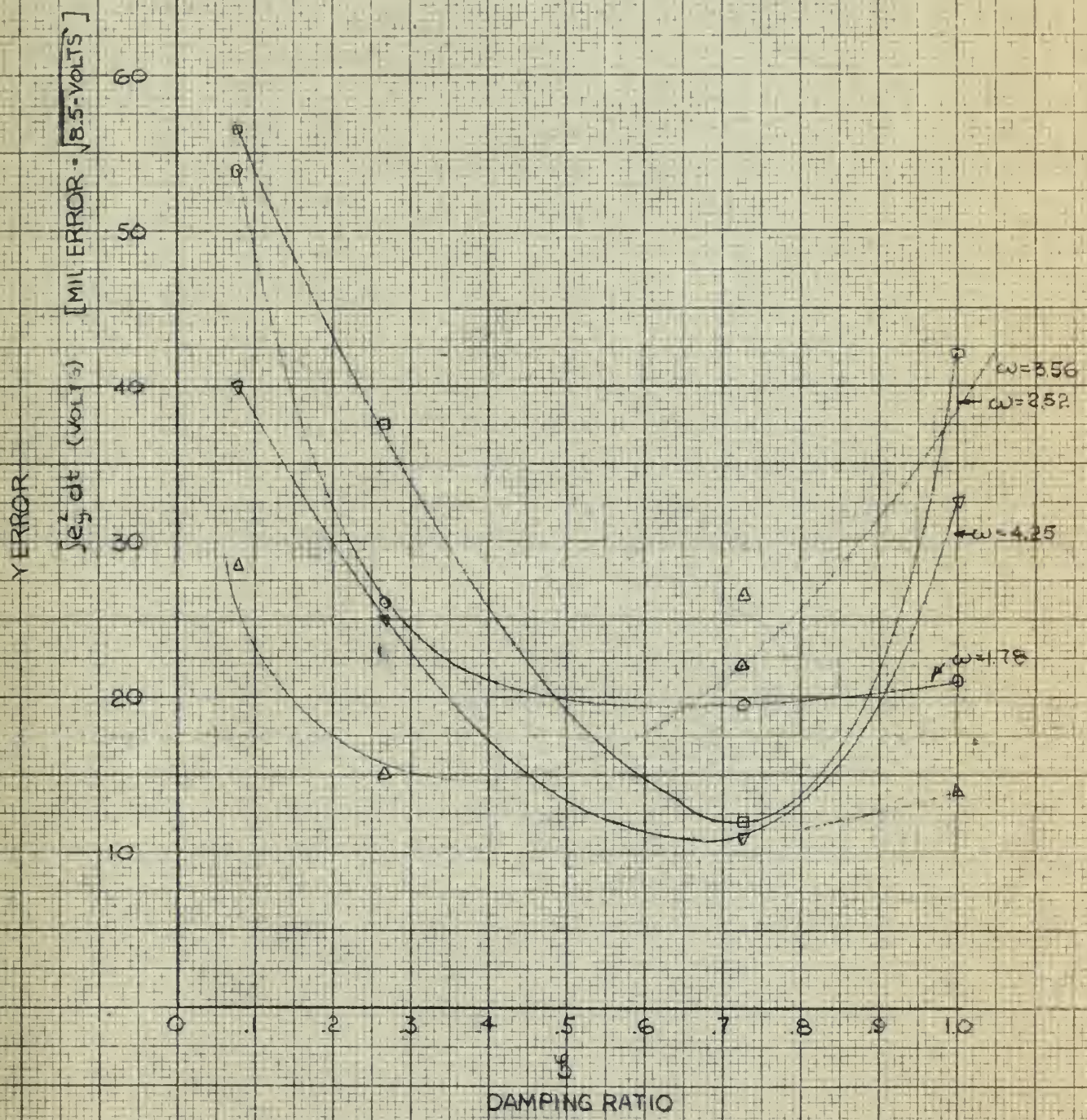

FIG 19
Y ERROR VERSUS ζ
FOR PILOT E

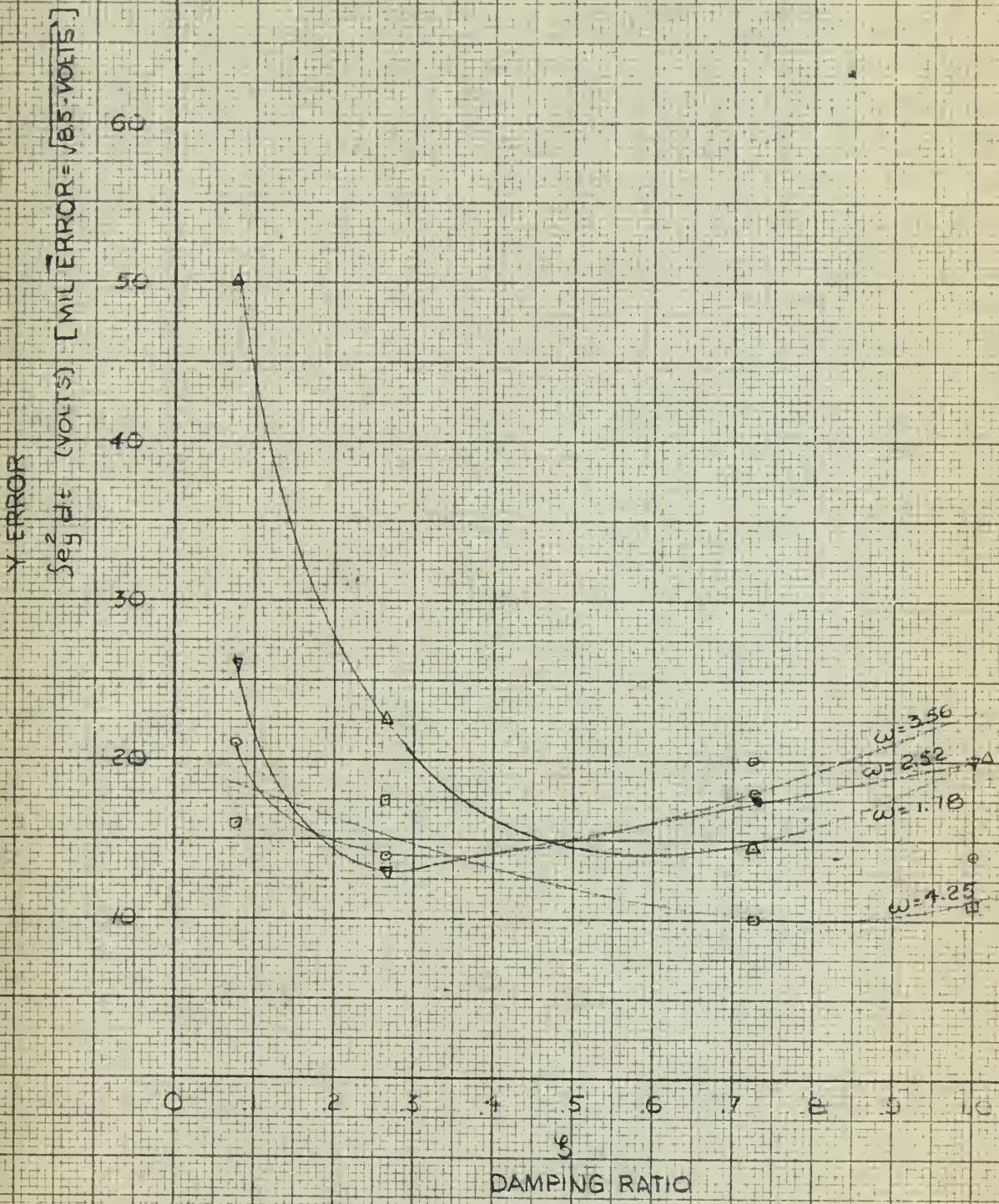

Fig. 120

Y Error versus (σ_w)

Pilot A: \square ∇ \diamond \triangle \circ
B \square ∇ \diamond \triangle \circ
C \square ∇ \diamond \triangle \circ
D \square ∇ \diamond \triangle \circ
E \square ∇ \diamond \triangle \circ
F \square ∇ \diamond \triangle \circ

$\gamma = .078$

Y ERROR
 $\int e^{\gamma^2 dt}$
[MEAN MIL ERROR - RMS VOLTS]

TIME TO DAMP TO $1/2$ AMPLITUDE (SECONDS)

(σ_w)

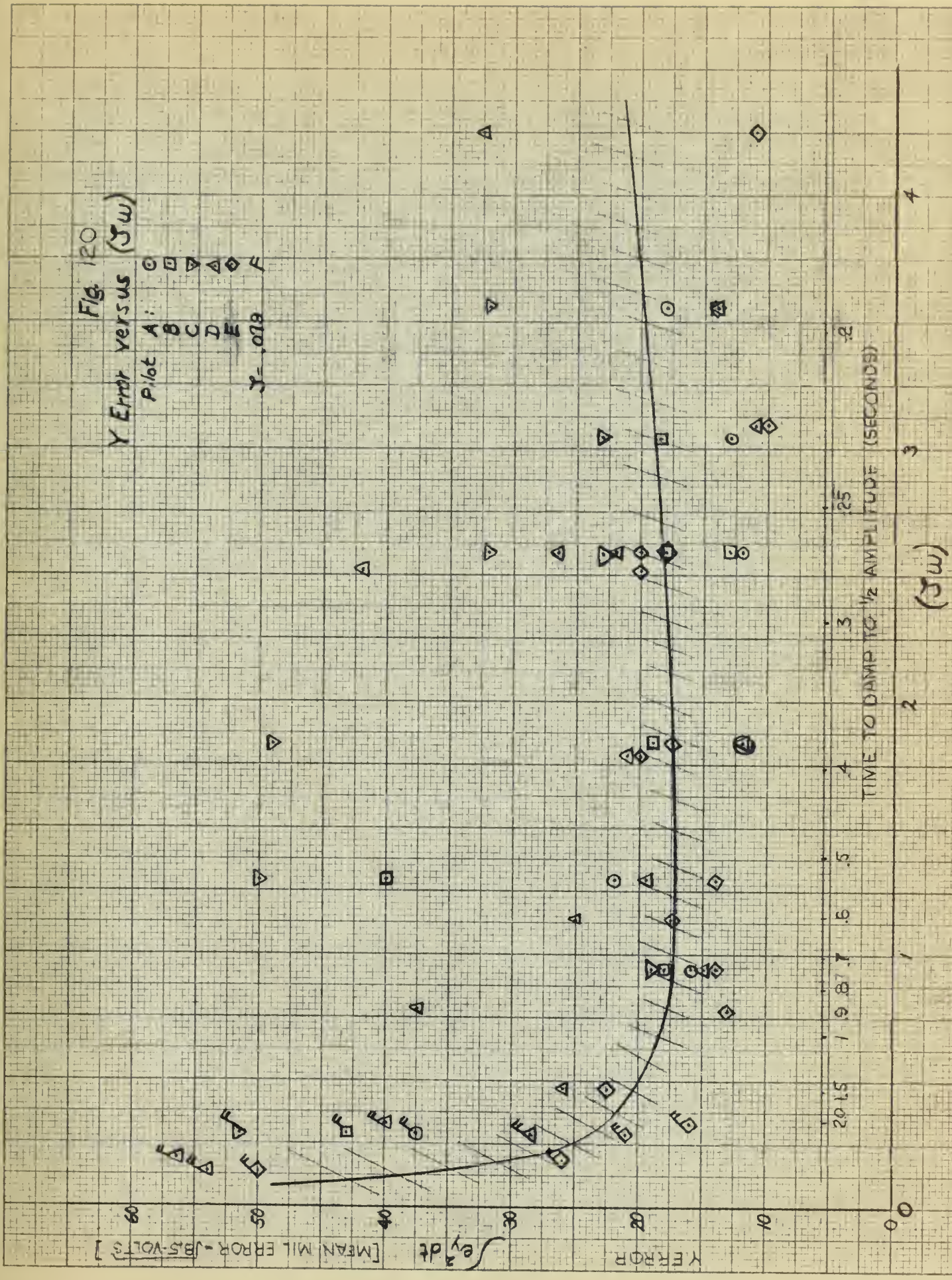

Y ERROR (VOLTS) [MEAN MIL ERROR = 18.5 VOLTS]

FIG. 2
 Y ERROR VERSUS ω
 AT CONSTANT δ
 $\delta = .727$
 PILOT A ○
 PILOT B △
 PILOT C ×
 PILOT D ◇
 PILOT E ◆

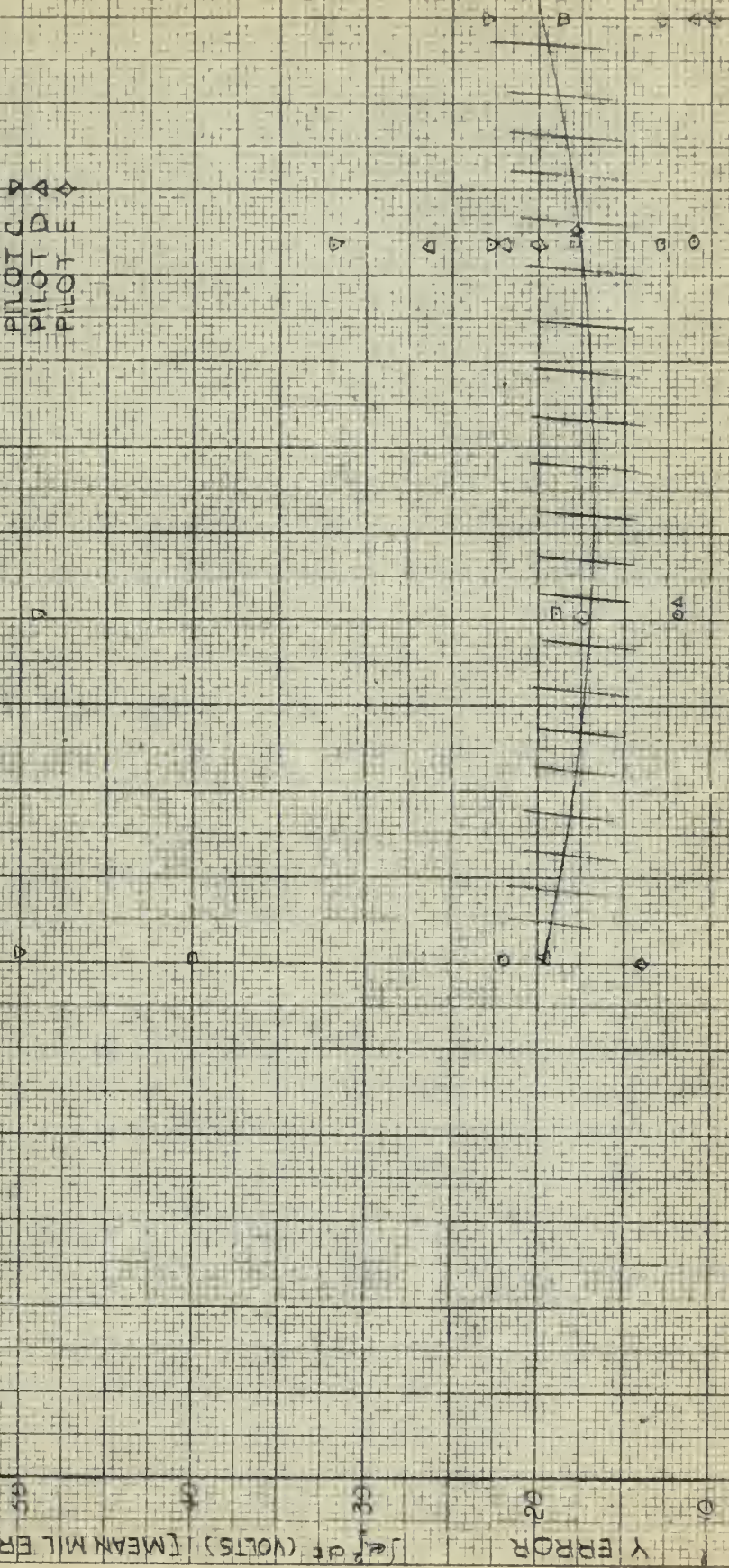

0 1 2 3 4
 AIRPLANE NATURAL FREQUENCY (RAD/SEC)

FIG 22
Y ERROR VERSUS ω

PILOT D

- Δ $\delta = 0.179$
- ∇ $\delta = 0.266$
- \square $\delta = 1.0$
- \circ $\delta = 7.27$

Y ERROR $\int e^2 dt$ (VOLTS)
[MEAN MIL ERROR - (RMS VOLTS)]

ω

AIRPLANE NATURAL FREQUENCY (RAD/SEC)

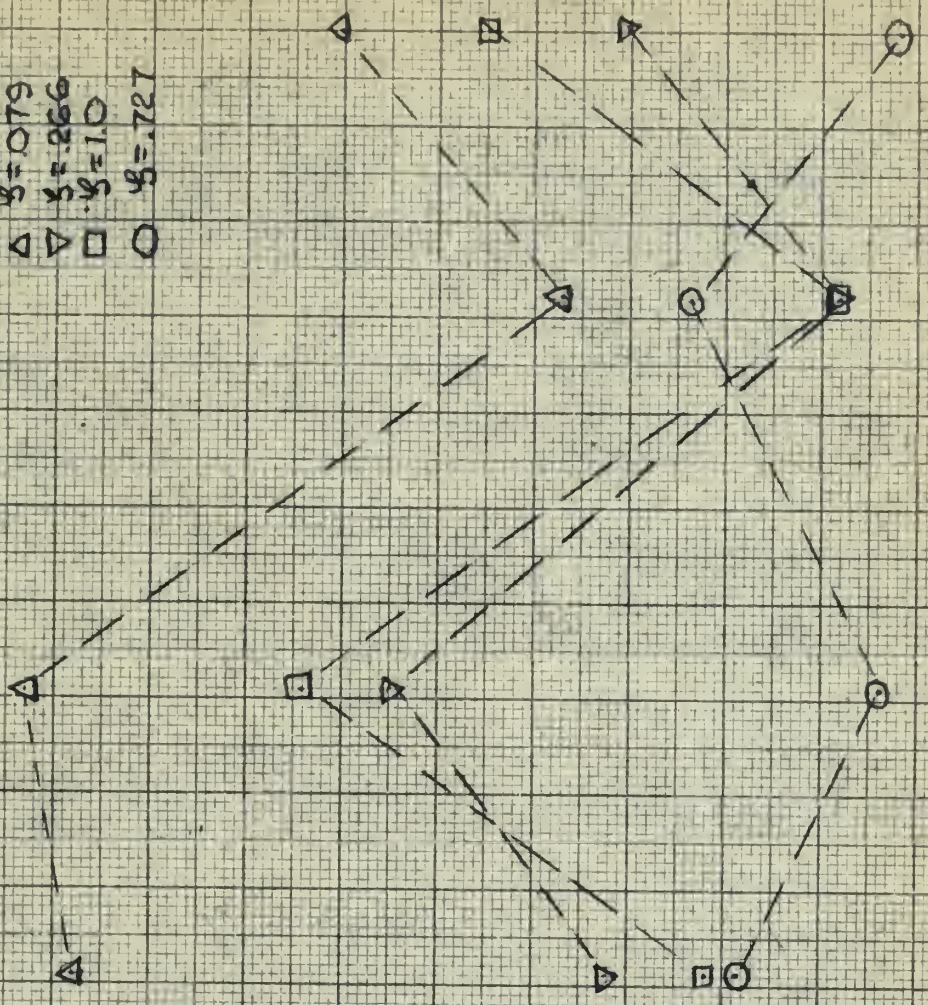
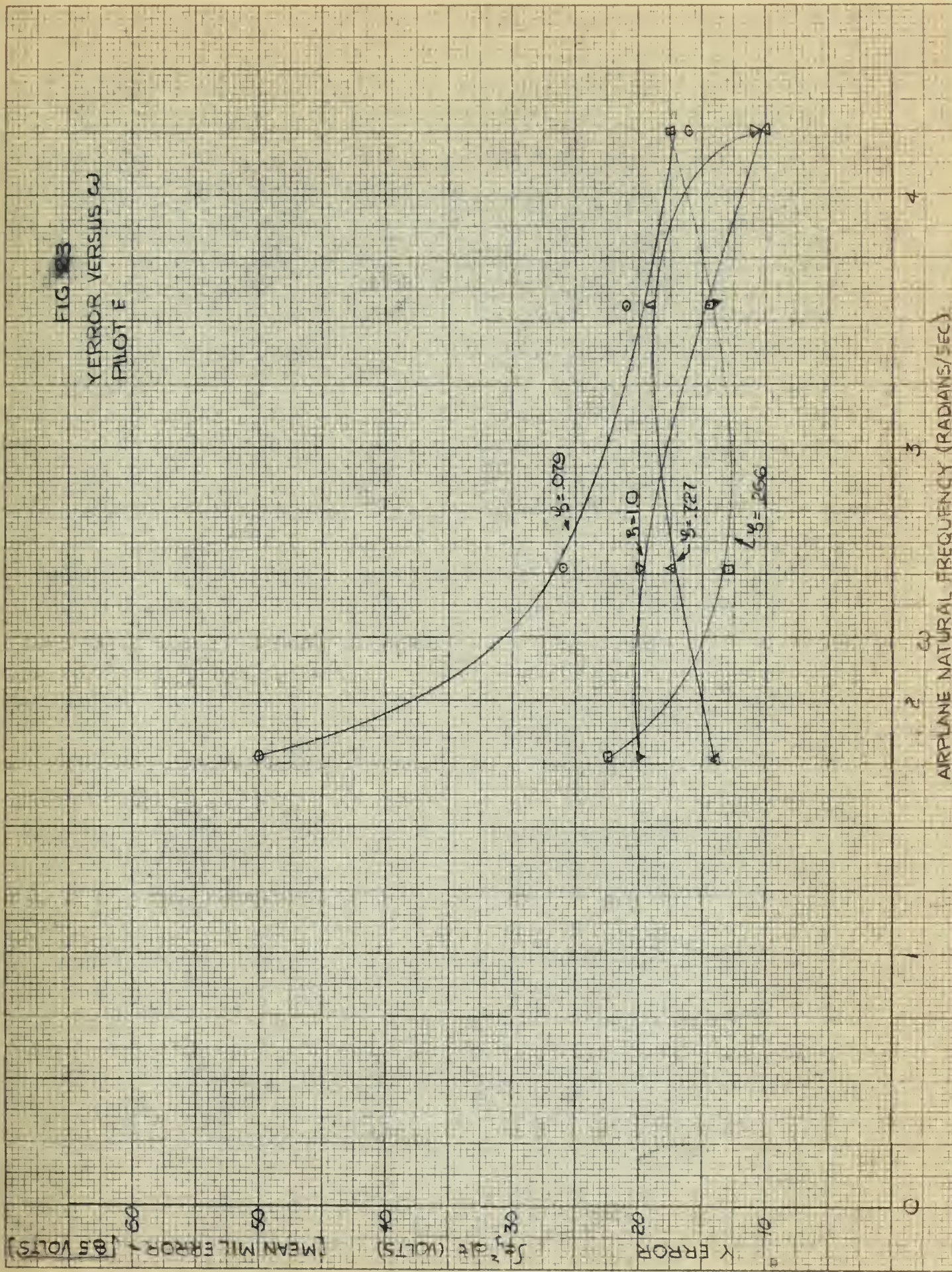



FIG. 23
ERROR VERSUS ω
PILOT F



AIRPLANE NATURAL FREQUENCY (RAD/SEC)

4

3

2

0

MEAN MIL ERROR - (85 VOLTS)

80

60

40

20

0

St. Error (VOLTS)

30

20

10

0

K ERROR

01

02

03

04

05

06

FIG. 24
ERROR VS. DAMPED FREQUENCY

Pilot A B C D E F
S=0.079

ERROR $\int e^2 dt$ (volts)
[MEAN MIL ERROR = 1.85 VOLTS]

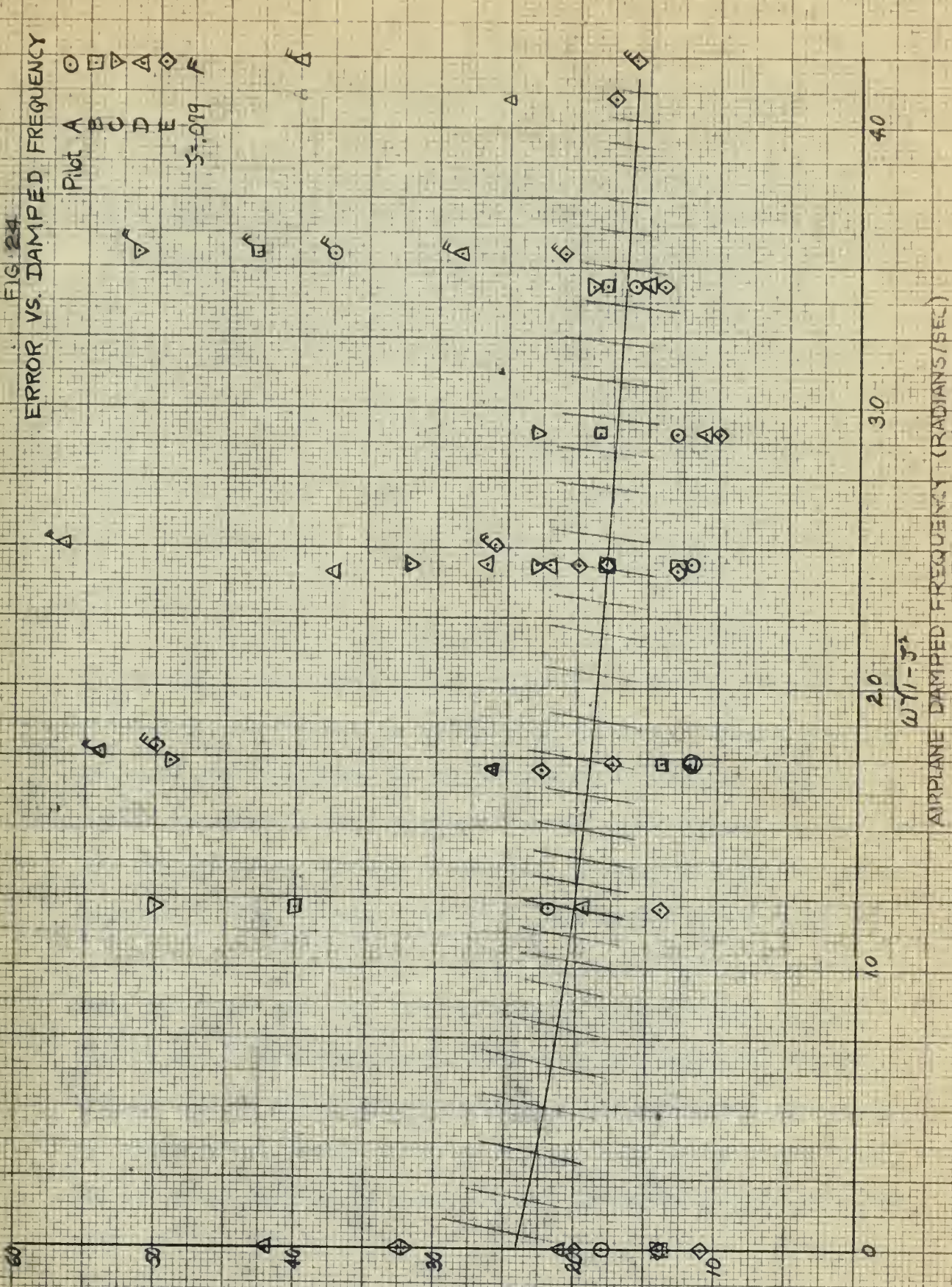

AIRPLANE DAMPED FREQUENCY (RAD/SEC)

$\omega \sqrt{1 - \zeta^2}$

10

20

30

40

APPENDIX A

DETAILS OF THE TWO-CHANNEL PORTABLE TAPE RECORDER

Playing the frequency-modulated test records back through the telemeter console resulted in the conversion of each test record to a fluctuating DC voltage which varied from zero to negative 100 volts. The DC voltage signal representing a displacement fluctuates at one cycle per second or less, and therefore must be impressed upon an AC carrier frequency in a modulator before recording. The use of the AC carrier created the requirement for a demodulator in the playback circuit before the test record goes to the analog computer reducing circuit. An output filter was also found to be necessary to remove pickup and noise.

A Crestwood Model 404 portable tape recorder was procured with an extra case, power supply, preamplifier unit, and recording head. The recorder was modified by substituting the extra recording head for the erase head with which the device is normally equipped, in order to provide two channels for recording noise and error signals simultaneously. The Crestwood recorder, as modified, is designated unit "A" in the remainder of this appendix. The extra power supply and preamplifier were installed in the second case for the second channel. The second case, designated unit "B", also contains the dual modulator circuits and the dual demodulator-output filter circuits. Each modulator circuit consists of an R-C balanced bridge of four germanium diodes, with the input passing through a voltage divider to adjust the signal level and the output filtered to remove all but the amplitude-modulated 4,000 cycle carrier. The AC carrier is provided by an external Jackson variable frequency oscillator. Each demodulator circuit, consisting of two

germanium diodes and two capacitors, is followed by an R-C output filter. See Figs. A-1 and A-2 for block and circuit diagrams. The two Crestwood cases thus contained all the circuitry needed except the Jackson oscillator, which was required only for recording. The calibration of the two-channel portable tape recorder is described under Data Reduction and Presentation.

OPERATING INSTRUCTIONS FOR THE TWO-CHANNEL PORTABLE TAPE RECORDER

See Fig. A-2 for sketch of connections.

To record:

1. Turn on power ("monitor volume") switch on each unit.
2. Set "tone" control to full clockwise position on each unit.
3. Turn "selector" switch to "record" on each unit, and actuate "press to record" switch on each unit.
4. Engage tape drive on unit "A" and commence input signal.
5. Set "record volume" on each unit to bring electron ray tuning indicator shadow to a thin line.

To play back:

1. Turn "selector" switch to "play" on each unit.
2. Return "press to record" switch to "up" or "play" position on each unit.
3. Engage tape drive.
4. Adjust "monitor volume" on each unit to provide desired signal level on the appropriate channel.

Further information the Crestwood recorder as purchased is contained in the instruction booklet and service manual.

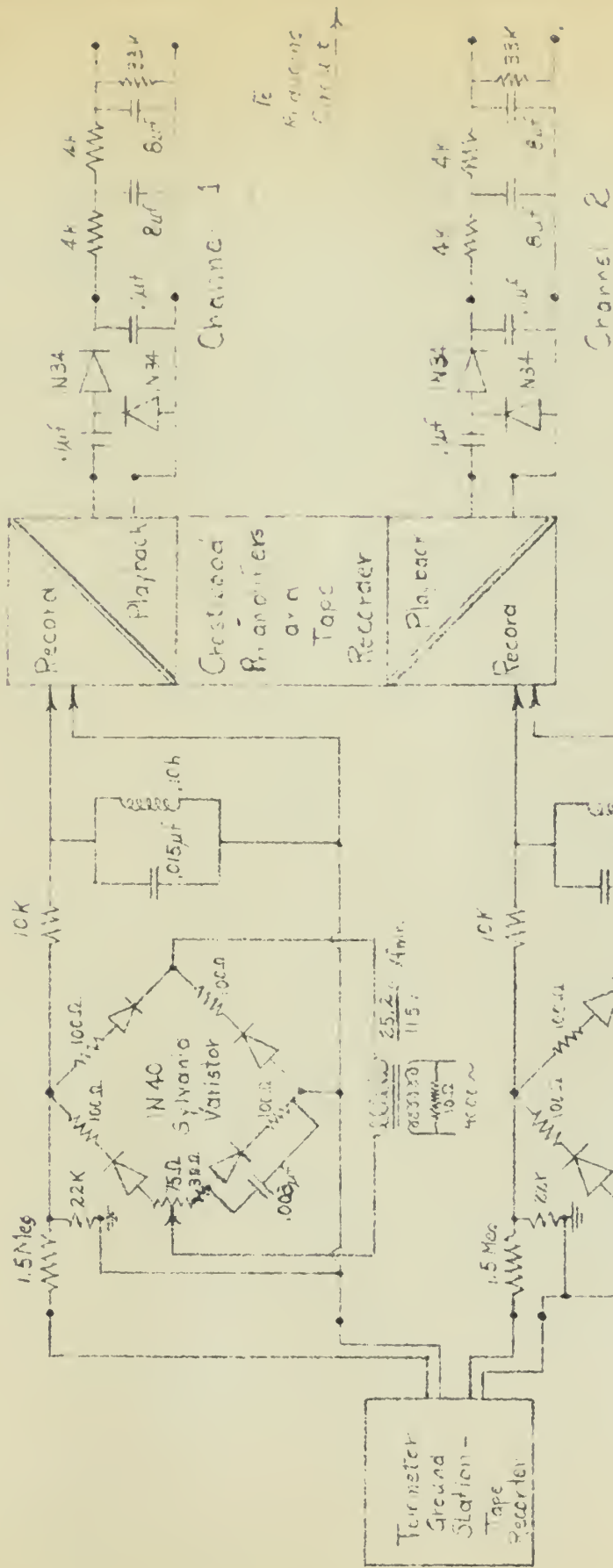

Fig. A-1
 MODULATOR AND
 DEMODULATOR - FILTER CIRCUITS
 FOR PORTABLE TAPE RECORDER

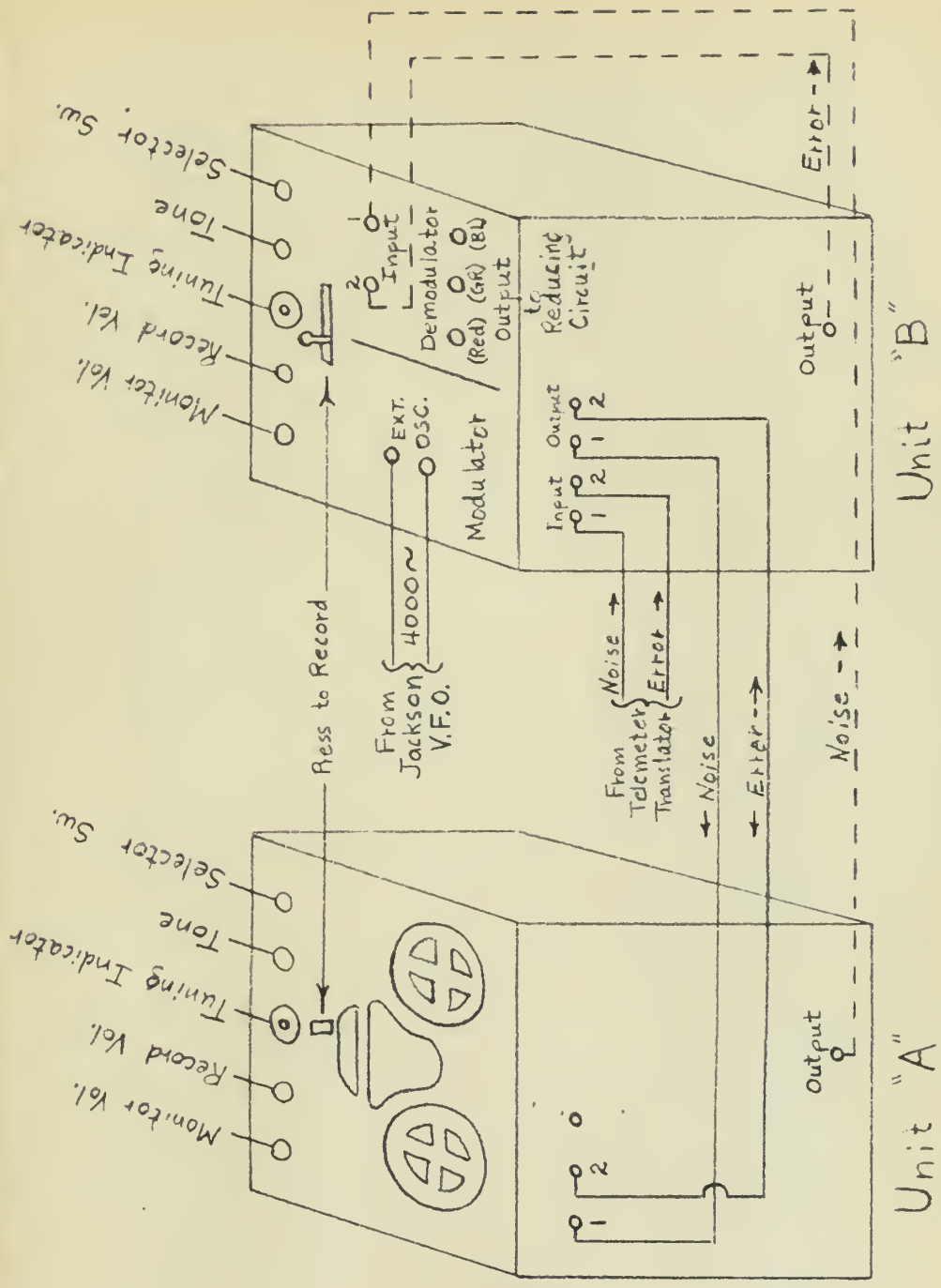

Fig. A-2
 Connections for Portable Tape
 Recorder Units





thesH726

The effects of airplane stability charac



3 2768 002 06940 3

DUDLEY KNOX LIBRARY

e.1