





Class TJ 206

Book F 82

Copyright N^o 1921

COPYRIGHT DEPOSIT.





CAMS

ELEMENTARY AND ADVANCED

BY

FRANKLIN DERONDE FURMAN, M.E.

Professor of Mechanism and Machine Design
at Stevens Institute of Technology
Member of American Society of Mechanical Engineers

ELEMENTARY CAMS

FIRST EDITION (THIRD IMPRESSION)

TOTAL ISSUE FOUR THOUSAND

CAMS—ELEMENTARY AND ADVANCED

FIRST EDITION

NEW YORK

JOHN WILEY & SONS, Inc.

LONDON: CHAPMAN & HALL, LIMITED

1921

T J206
F82
1921

Copyright, 1916, 1921
BY
FRANKLIN DeRONDE FURMAN

FEB -3 1921

\$3.00

PRESS OF
BRAUNWORTH & CO.
BOOK MANUFACTURERS
BROOKLYN, N. Y.

©Cl. A608208

21-1829

201

5746. 1921

PREFACE TO THE ENLARGED EDITION

THE first five sections of this book were published about three years ago under the title of "Elementary Cams." The chief features of this earlier book were that it pointed out a classification, an arrangement, and a general method of solution of the well-known cams in such manner as has been generally developed in other specialized branches in technical engineering work; and also it gave a series of cam factors for base curves in common use, which enabled designers to compute proper cam sizes for specific running conditions, offering numerous examples in the use of these factors in the several kinds of cam problems. The factors, with the exception of the one for the 30° pressure angle for the Crank Curve were new, so far as the author is aware. The "Elementary Cams" will continue to be sold as a separate volume.

A further development of the subject is given in the present work which is under the title of "Cams." The chief original features of this advanced work include the development or use, or both, of the logarithmic, cube, circular, tangential and involute base curves, the establishing of cam factors for such of these curves as have general factors, and the demonstration that the logarithmic base curve gives the smallest possible cam for given data.

The new material now introduced into the book includes, further, comparisons of the characteristic results obtained from *all* base curves, in which the relative size of each cam, and the relative velocity and acceleration produced by each, is shown graphically in one combined group of illustrations, thus enabling the designer to glance over the entire field of theoretical cam design and quickly select the type that is best adapted for the work in hand. From these diagrams one may observe, for example, which form of cam is best adapted for gravity, spring or positive return, which is best for slow or fast velocities at various points in the stroke, and which ones are apt to develop "hard spots" in running. The involute curve is found to have its chief and characteristic theoretical advantage when it is used with an offset follower. The nature of the contact between cylindrical, conical and hyperboloidal roller pins, when used in connection with grooved cylindrical cams, has been investigated and pointed out. The subject of pure rolling contact between various forms of oscillating cam arm surfaces, and of the nature and amount of sliding action

of such surfaces has been developed so that the effects of wear due to rubbing may be confidently considered when such types of cams are under design.

While the whole purpose of this work has been to present the subject matter in graphical form and in the simplest possible manner so as to make it available to the greatest number, much mathematical investigation has been necessary and in this I have been greatly aided by my colleague Professor L. A. Hazeltine, M. E., head of the department of Electrical Engineering at Stevens, to whom I express my deep appreciation. The details of these investigations are not necessary here and are not set down, but their results are. These results are given in various formulas that are used in the solution of a number of the problems. These final formulas avoid the use of calculus and are mostly in such form as to be readily used by designers generally.

In closing, the author desires to introduce a personal thought that has grown up, and which is inseparable, with this book. Some years ago, before any special study was given by the writer to the subject of cams, it appeared that the whole subject of mechanism was so thoroughly covered by various text books and technical papers that the time in engineering development had arrived when there was but little for an instructor to look forward to in the way of production of extended original work on any given topic. To say the least such a thought was not at all encouraging, and so it is a pleasure now to the author, and it is hoped that it will be an inspiration particularly to the younger readers, to record that the study of this subject of cams has brought forth a great wealth of new and practical material which had not previously been brought to light and set down in the literature of the subject. Now that this work is done, the vastness of the "unknown," even in this present era of great accomplishments, is realized as it never was before, and it only remains to suggest that not only this topic of cams but many other topics in the science of engineering may offer opportunities for much further development and perfection on the part of those who have the desire for such work and the time to pursue it.

F. DER. FURMAN.

HOBOKEN, N. J., April, 1920.

CONTENTS

| | PAGES |
|---|-------|
| SECTION I.—DEFINITIONS AND CLASSIFICATION | 1-19 |
| Cams Follower Surfaces Radial or Disk Cams Side or Cylindrical Cams Conical and Spherical Cams | |
| Names of Cams—Periphery, Plate, Heart, Frog, Mushroom, Face, Wiper, Rolling, Yoke, Cylindrical, End, Double End, Box, Internal, Offset, Positive Drive, Single Acting, Double Acting, Step, Adjustable, Clamp, Strap, Dog, Carrier, Double Mounted, Multiple Mounted, Oscillating | |
| Definitions of Terms Used in the Solution of Cam Problems—Cam Chart, Cam Chart Diagram, Time Chart, Base Curve, Base Line, Pitch Line, Pitch Circle, Pitch Surface, Working Surface, Pitch Point, Pressure Angle | |
| Formula for Size of Cam for a Given Maximum Pressure Angle | |
| Table of Cam Factors for All Base Curves for Maximum Pressure Angles from 20° to 60° | |
| SECTION II.—METHOD OF CONSTRUCTION OF BASE CURVES IN COMMON USE | 20-24 |
| Straight Line Base Straight-Line Combination Curve Crank Curve Parabola Elliptical Curve | |
| SECTION III.—CAM PROBLEMS AND EXERCISE PROBLEMS | 25-74 |
| Problem 1, Empirical Design Problem 2, Technical Design. | |
| Advantages of Technical Design Problem 3, Single-Step Radial Cam, Pressure Angle Equal on Both Strokes Omission of Cam Chart Problem 4, Single-Step Radial Cam, Pressure Angles Unequal on Both Strokes | |
| Pressure Angle Increases as Pitch Size of Cam Decreases Change of Pressure Angles in Passing from Cam Chart to Cam Cam Con- sidered as Bent Chart. Base Line Angles Before and After Bending | |
| Limiting Size of Follower Roller Radius of Curvature of Non- Circular Arcs | |
| Problem 5, Double-Step Radial Cam Determination of Maximum Pressure Angle for a Multiple-Step Cam | |
| Problem 6, Cam with Offset Roller Follower Problem 7, Cam with Flat Surface Follower Limited Use of Cams with Flat Surface Followers | |
| Problem 8, Cam with Swinging Follower Arm, Roller Contact— Extremities of Swinging Arc on Radial Line Problem 9, Cam with Swinging Follower Arm, Roller Contact—Swinging Arc, Con- tinued, Passes Through Center of Cam Effect of Location of Swinging Follower Arm Relatively to the Cam | |

| | PAGES |
|--|---------------------------------------|
| Problem 10, Face Cam with Swinging Follower | Problem 11, |
| Cam with Swinging Follower Arm, Sliding Surface Contact | Data |
| Limited for Followers with Sliding Surface Contact | |
| Problem 12, Toe and Wiper Cam | Modifications of the Toe |
| and Wiper Cam | |
| Problem 13, Single Disk Yoke Cam | Limited Application of |
| Single Disk Yoke Cam | Problem 14, Double Disk Yoke Cam |
| Problem 15, Cylindrical Cam with Follower that Moves in a | |
| Straight Line | Refinements in Cylindrical Cam Design |
| Problem 16, Cylindrical Cam with Swinging Follower | Chart Method |
| for Laying Out a Cylindrical Cam with a Swinging Follower Arm | |
| Exercise Problems, 3a to 16a | |
| SECTION IV.—TIMING AND INTERFERENCE OF CAMS | 75- 78 |
| Problem 17, Cam Timing and Interference | Location of Key- |
| ways | Exercise Problem 17a |
| SECTION V.—CAMS FOR REPRODUCING GIVEN CURVES OR FIGURES | 79- 87 |
| Problem 18, Cam Mechanism for Drawing an Ellipse | Prob- |
| lem 18a, Exercise Problem for Drawing Figure 8 | Problem 19, |
| Cam for Reproducing Handwriting Using Script Letters Ste | |
| Method of Subdividing Circles into Any Desired Number of Equal | |
| Parts | |
| SECTION VI.—ADVANCED GROUP OF BASE CURVES | 88-137 |
| Complete List and Comparison of Base Curves, Their Appli- | |
| cations and Characteristic Motions | Velocity and Acceleration |
| Diagrams Showing Characteristic Action of Various Cams | All- |
| logarithmic Curve Gives Smallest Possible Cam for a Given Pres- | |
| sure Angle | |
| Problem 20, All-logarithmic Cam | General Analysis |
| Construction of Logarithmic Curve and Cam by Analytical and | Detail |
| Graphical Methods | |
| Problem 21, Logarithmic-combination Cam with Parabolic | |
| Easing-off Arcs | |
| Problem 22, Cam with Straight-Line Base | |
| Straight-Line Combination Curve | Crank Curve |
| Effect | |
| of Crank Curve Following Its Tangent Closely | Parabola |
| Gravity Curve | Curve of Squares |
| Perfect Cam Action | |
| Comparison of Parabola and Crank Curves | |
| Problem 23, Tangential Cam, Case 1 | Graphical and Ana- |
| lytical Methods | Characteristic Retardation |
| Problem 24, Circular Base Curve Cam, Case 1 | Elliptical Base |
| Curve | Effect of Varying Axes of Ellipses |
| Elliptical Base | |
| Curve Equivalent to Nearly All Other Base Curves | |
| Cube Curve Symmetrically and Unsymmetrically Applied | |
| Problem 25, Cube Curve Cam, Case 1 | |

| | PAGES |
|--|----------------|
| Cams Specially Designed for Low-Starting Velocities | |
| Problem 26, Circular Base Curve Cam, Case 2 | |
| Problem 27, Cube Curve Cam, Case 2 | |
| Problem 28, Tangential Cam, Case 2 | |
| SECTION VII.—CAM CHARACTERISTICS | 138-156 |
| Methods of Determining Velocities and Accelerations | |
| Time-Distance, Time-Velocity and Time-Acceleration Diagrams | |
| Degree of Precision Obtained by Graphical Methods | |
| Comparison of Relative Velocities and Forces Produced by Cams of Different | |
| Base Curves | |
| Cam Follower Returned by Springs | |
| Relative Strength of Spring Required for Cams of Different Base Curves | |
| Special Adaptation of Cube Curve Cam for Follower Returned | |
| by a Spring | |
| Nature of Pressure between Cam Surface and | |
| Spring-Returned Follower | |
| Accuracy in Cam Construction | |
| Regulation of Noise | |
| High-Speed Cams | |
| Balancing of Cams | |
| Pressure Angle Factors, Nature of Application and Method of | |
| Determination for All Base Curves | |
| Varied Forms of Funda- | |
| mental Base Curves | |
| Chart Showing Values of Intermediate | |
| Pressure Angles from 20° to 60° for all Cams | |
| SECTION VIII.—MISCELLANEOUS CAM ACTIONS AND CONSTRUCTIONS . | 157-229 |
| Variable Angular Velocity in Driving Cam Shaft | |
| Problem 29, Oscillating Cam Having Variable Angular Velocity, | |
| Toe and Wiper Type | |
| Problem 30, Wiper Cam Operating Curved-Toe Follower | |
| Problem 31, Sliding Action between Cam and Flat Follower Sur- | |
| faces | |
| Rate of Sliding Measured | |
| Velocity of the Follower | |
| Measured | |
| Problem 32, Sliding Action between Cam and Curved-Toe Fol- | |
| lower | |
| Problem 33, Sliding Action where Driving Cam Has Variable | |
| Angular Velocity | |
| Elimination of All Sliding Action between Cam and Flat or | |
| Curved Surface Follower | |
| The Principle of Pure Rolling Action between Cam Surfaces | |
| Well-Known Curves that Lend Themselves Readily to Pure | |
| Rolling Cam Action | |
| Problem 34, Pure Rolling with Flat-Surface Follower | |
| Use of Logarithmic Curve for Pure Rolling Action | |
| Characteristic Properties of the Logarithmic Curve | |
| Problem 35, Pure Rolling with Logarithmic Curved Cam Arm | |
| Angular Motion of Each Arm | |
| Tangency of Logarithmic Cam | |
| Surfaces | |
| Regulation of Pressure Angle when Logarithmic | |
| Rolling Cams are Used | |
| Derived, or Computed Curves for Rolling Cam Arms | |

| | PAGES |
|---|-------|
| Problem 36, The Use of a Derived Curve for Rolling Cam Arms | 174 |
| Rolling Cam Arms Useful for Starting Shafts Gradually | |
| Regulation of Pressure Angle with Derived Rolling Cams | |
| Elliptical Arcs for Pure Rolling Cam Arms | |
| Problem 37, Elliptical Rolling Cam Arms, Angles of Action Equal | |
| Determination of Major and Minor Axes of Ellipses | |
| Construction of Ellipse | |
| Pressure Angle in Rolling Elliptical Cam Arms | |
| Problem 38, Elliptical Rolling Cam Arms, Angles of Action | |
| Unequal | |
| Pure Rolling Parabolic Cam Surfaces for a Reciprocating Motion | |
| Problem 39, Rolling Parabolas | |
| Construction of Parabola | |
| Pure Rolling Hyperbolic Cam Arms where Centers are Close | |
| Together | |
| Problem 40, Rolling Hyperbolas | |
| Construction of Hyperbola | |
| Detail Drawing of Cylindrical Cams | |
| The True Maximum | |
| Pressure Angle in Cylindrical Cams | |
| Drawing of Groove Out- | |
| lines, Approximate and More Exact Methods | |
| Forms of Follower Pins for Cylindrical Grooved Cams | |
| Line of | |
| Contact between Pin and Groove Surface, at Rest and Moving | |
| The Cylindrical Follower Pin | |
| The Conical Follower Pin | |
| The | |
| Hyperboloidal Follower Pin | |
| Plates for Cylindrical Cams | |
| Adjustable Cylindrical Cams for | |
| Automatic Work | |
| Double-Screw Cylindrical Cams | |
| Periods of Rest of More | |
| than One Revolution in Cylindrical Cams | |
| Slow-advance and | |
| Quick-Return Secured by Double-Screw Cam | |
| Straight-Sliding Plate Cams | |
| Involute Cams | |
| Construction of Involute Curve | |
| Pressure | |
| Angle with Involute Cam | |
| Involute Cam Specially Adapted for Flat-Surface Follower | |
| Problem 41, Involute Cam with Radial Follower | |
| Oscillating Positive-Drive-Single-Disk Cam | |
| Cam Shaft Acting | |
| as Guide | |
| Positive Drive with Cam Shaft as Guide | |
| Positive- | |
| Drive Double-Disk Radial Cam with Swinging Follower | |
| Rotary- | |
| Sliding Yoke Cams Giving Intermittent Harmonic Motion, and | |
| Reciprocating Motion | |
| Rotary Sliding Yoke Cam, General Case | |
| Cam Surface on Reciprocating Follower Rod | |
| Problem 42, Definite Motion where Cam Surface is on Follower | |
| Rod | |
| Problem 43, Cam Surface on Swinging Follower Arm | |
| Effect of Swinging Transmitter Arm between Ordinary Radial | |
| Cam and Follower | |
| Angular Velocity Curve for a Swinging | |
| Follower Arm | |
| Velocity Curve for a Follower Rod with Com- | |
| parison of Results Obtained by Using Transmitter Arms with | |
| Sliding and Roller Action | |
| Diagram of Pressure Angles | |
| Measurement of Rubbing Velocities in Cams Having Sliding Action | |
| Boundary of Follower Surface Subjected to Wear in Sliding Cams | |

CONTENTS

ix

| | PAGES |
|---|-------|
| Cam Action Different on Forward and Return Strokes with Sliding Cams | 222 |
| Problem 44, Small Cams with Small Pressure Angles Secured by Using Variable Drive | |
| Variable Drive by Whitworth Motion | |
| Swash Plate Cam | |
| Uniformly Rotating Cam Giving Intermittent Rotary Motion | |
| The Eccentric a Special Type of Cam | |
| An Example of a Time-Chart Diagram for Eleven Cams on One Shaft of an Automatic Machine | 229 |



ELEMENTARY CAMS

SECTION I.—DEFINITIONS AND CLASSIFICATION

DEFINITIONS

1. CAMS are rotating or oscillating pieces of mechanism having specially formed surfaces against which a follower slides or rolls and thus receives a reciprocating or intermittent motion such as cannot be generally obtained by gear wheels or link motions.

Various forms of cams are illustrated at *C* in Figs. 1 to 10. The follower in each case is shown at *F*, all having roller contact except the ones shown in Figs. 7 and 8. The former has a *V* edge and the latter a plane surface in contact with the cam and both have sliding action.

2. FOLLOWER EDGES OR ROLLERS may have motion in a straight line as from *D* to *G*, Fig. 7, or in a curved path depending on suitably constructed guides or on swinging arms. The total range of travel of the follower may be accomplished by one continuous motion, or by several separate motions with intervals of rest. Each motion may be either constant or variable in velocity, and the time used by the motion may be greater or less, all according to the work the machine has to do and to the will of the designer.

CLASSIFICATION

3. Cams may be most simply, and at the same time most completely, classified according to the motion of the follower with respect to the axis of the cam, as:

(a) RADIAL OR DISK CAMS, in which the radial distance from the cam axis to the acting surface varies constantly during part or all of the cam cycle, according to the data. The follower edge or roller moves in all cases in a radial, or an approximately radial, direction with respect to the cam. Various forms of radial cams are illustrated in Figs. 1, 2, 7, 8, and 9.

(b) SIDE OR CYLINDRICAL CAMS, in which the follower edge or roller moves parallel to the axis of the cam, or approximately in

this direction. Several types of side cams are shown in Figs. 3, 4, and 10.

Nearly all the cams referred to in the above figures illustrating the two general classes of radial and side cams respectively have special or local trade names which will be pointed out in a succeeding paragraph.

(c) CONICAL and (d) SPHERICAL cams, in which the follower edge or roller moves in an inclined direction having both radial and longitudinal components with respect to the axis of the cam as illustrated in Figs. 5 and 6.

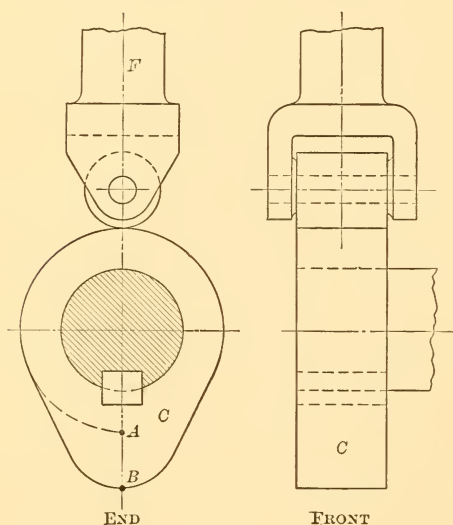

FIG. 1.—RADIAL CAM AND FOLLOWER,
• ROLLER CONTACT

4. NAMES OF CAMS. Cams, in popular usage, have come to be known by a wide range of names, the same cam often being designated by a number of different names according to geographical location and personal preference and surroundings of the cam builder or user. This is an unfortunate condition, and in the general classification in the preceding paragraph an endeavor is made to establish a fun-

damental basis for clarifying and simplifying the nomenclature of cams as much as possible. In a treatise of this kind, however, it is essential that, at least, the more common of the ordinary working terms be recognized and defined, and that the cams under their popular names be properly placed in the fundamental classification given in the preceding paragraph.

The following specially named cams fall under the classification of radial cams:

(e) PERIPHERY CAMS, in which the acting surface is the periphery of the cam, as illustrated in Figs. 1, 7, and 9. While these are examples of true periphery cams, it must be recorded that the cylindrical grooved cam, shown in Fig. 3, is also known to some extent as a periphery cam, due no doubt to the fact that in designing this

cam the original layout for the contour of the groove is first made on a flat piece of paper, which is then wrapped on to the surface or "periphery" of the cylinder. Since the contour line of the groove which lies on the periphery is merely a guiding line for cutting the groove, and since the side surface of the groove is the working surface, it is, to say the least, a misnomer to designate such a cam as a periphery cam.

(f) **PLATE CAMS**, in which the working surface includes the full 360°, and forms either the periphery of the cam, or the sides of a

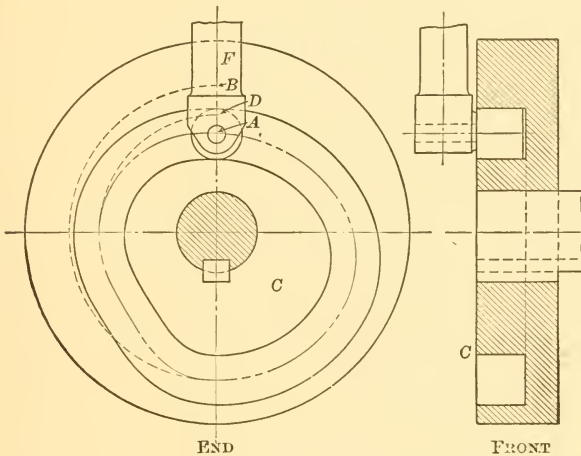

FIG. 2.—FACE CAM AND FOLLOWER

groove cut into the face of the cam plate, as illustrated in Figs. 1 and 2 respectively. Figs. 7 and 9 also show plate cams.

(g) **HEART CAMS**, in which the general form is that which the name implies. See Fig. 7. In this type of cam there are two distinct symmetrical lobes, often so laid out as to give uniform velocity to the driver. In this case each lobe would be bounded by an Archimedean spiral with the ends cased off.

(h) **FROG CAM**, in which the general form includes several lobes more or less irregular, as illustrated, for example at *C* in Fig. 9.

(i) **MUSHROOM CAM**, in which the periphery of a radial or disk cam works against a flat surface, usually a circular disk at right angles to the cam disk, instead of against a roller, see Fig. 44.

(j) **FACE CAM**, also called a Groove, but more properly a Plate Groove cam, to distinguish it from the Cylindrical Groove cam, in which a groove is cut into the flat face of the cam disk. In

this form of cam shown in Fig. 2 the roller has two opposite lines of contact, one against each side of the groove, when the roller has a snug fit. The plate or disk in which the groove is cut is generally circular; but it may be cast to conform with the contour of the groove, or it may be built with radial arms supporting the irregular grooved rim. In the latter case it lacks resemblance to the face

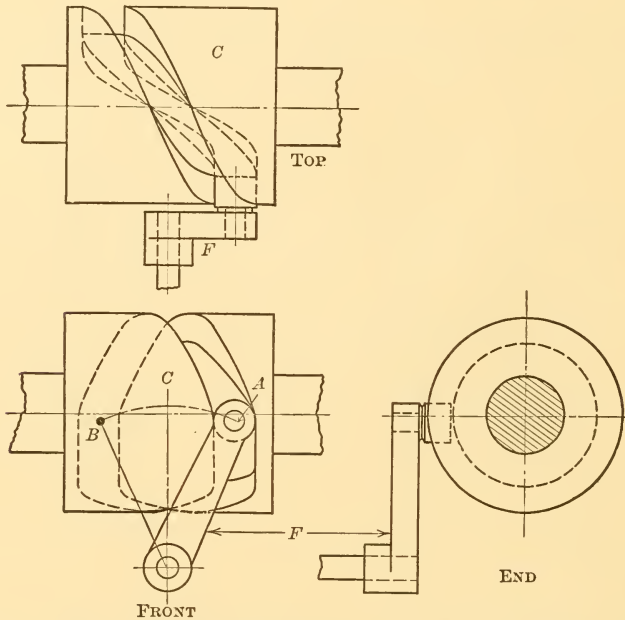

FIG. 3.—CYLINDRICAL CAM AND SWINGING FOLLOWER

cam, but nevertheless it must, because of the nature of its action, be classed with it. The face cam, as ordinarily considered and as illustrated in Fig. 2, is better adapted for higher speeds because of its more nearly balanced form of construction. Against this, however, must be considered one of two disadvantages, either the high rubbing velocity of the roller against one side of the groove when the roller is a snug fit, or lost motion and noise as the working line of contact changes from one side of the groove to the other when the roller has a loose fit. The most important advantage of the face cam, that of giving positive drive, will be considered in paragraph 9. The term groove cam might be applied, with advantage in clearness of meaning, to such face cams as are cut or cast on non-circular plates.

(k) WIPER CAM, which has an oscillating motion, and is constructed usually with a long curved arm in order that it may "wipe" or rub along the plane surface of a long projecting "toe," or follower. The wiper cam is used generally to give motion to a follower which moves straight up and down as shown from F to F' in Fig. 8. This, however, is not essential and the follower may also have a swinging

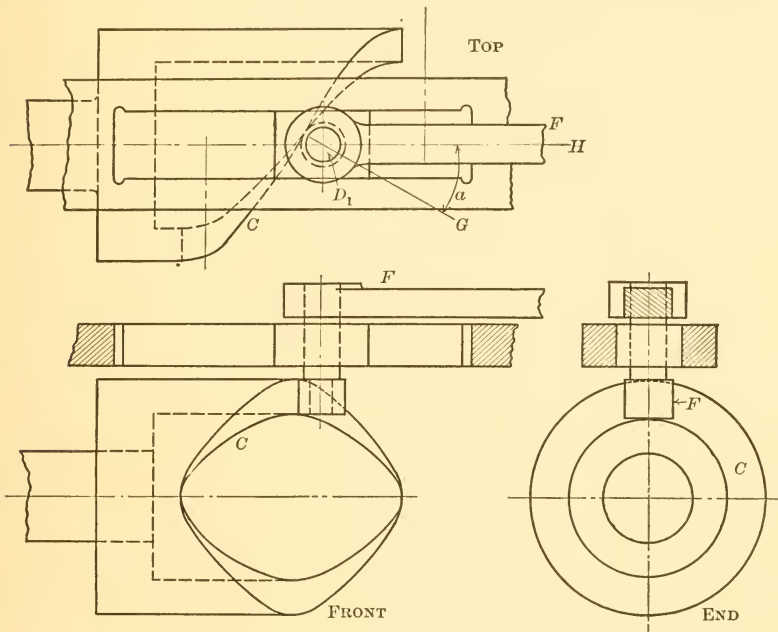

FIG. 4.—END CAM AND FOLLOWER

motion. The disadvantage of sliding friction, which is inseparable from the wiper cam, is balanced to some extent by the fact that the very sliding permits, within certain range, of the assignment of specified intermediate velocities between the starting and stopping points which cannot be obtained with similar forms of cams which have pure rolling action.

(l) ROLLING CAM, which greatly resembles the wiper cam in general appearance, but which is totally different in principle, for the curves of the cam and follower surfaces are specially formed so as to give pure rolling action between them. The rolling cam is specially well adapted to cases where both driver and follower have an oscillating motion and where the velocities between the starting and stopping points are not important and are not specified.

(m) YOKE CAM, a form of radial cam in which all diametral lines drawn across the face and through the center of rotation of the cam are equal in length. This form of cam permits the use of two opposite follower rollers whose centers remain a fixed distance apart, to roll simultaneously on opposite sides of the cam, and thus give positive motion to the follower. For illustration, see Fig. 9.

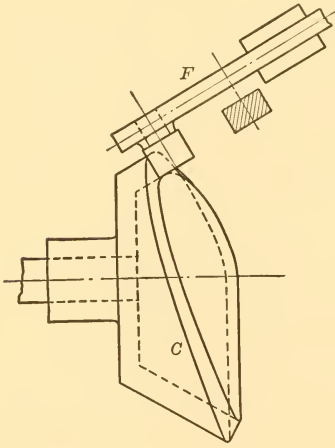

FIG. 5.—CONICAL CAM AND RECIPROCATING FOLLOWER

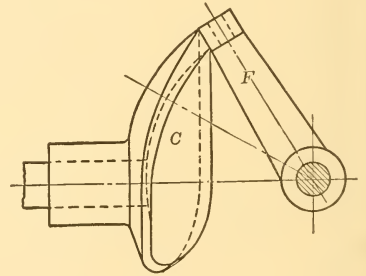

FIG. 6.—SPHERICAL CAM AND SWINGING FOLLOWER

Yoke cams may be, and frequently are, made of two disks fixed side by side, the peripheries being complementary to each other and the two rollers of the yoke rolling on their respective cam surfaces, as shown in Fig. 56. The advantage of yoke cams is that they give positive motion with pure rolling of the follower roller, there being contact on only one side of the roller in contradistinction to the double contact of the roller which exists in face and groove cams.

5. The following specially named cams fall under the general classification of side cams.

These include cams that have been made from blank cylindrical bodies by using a rotary end cutter with its axis at right angles to the axis of the cylinder and by moving the axis of the rotary cutter parallel to the axis of the cylinder while the cylinder rotates. A groove of desired depth is thus left in the cylinder, Fig. 3, or the end of a cylindrical shell is thus milled to a desired form, Fig. 4. A side cam may also be formed by screwing a number of formed

clamps on to a blank cylinder, the sides of the clamps thus acting as the working surface as illustrated in Fig. 11. All types of side cams may properly be considered as derived from blank cylindrical forms, and, therefore, the name "cylindrical cam" could be regarded as synonymous with side cam; but general custom has limited the use of the term cylindrical cam to the "barrel" or "drum" type mentioned below:

(n) **CYLINDRICAL CAM**, also called Barrel cam, Drum cam, or Cylindrical Groove cam, in which the groove, cut around the

cylinder, affords bearing surface to the two opposite sides of the follower roller, thus giving positive motion, as illustrated in Fig. 3.

(o) **END CAM**, in which the working surface has been cut at the end of a cylindrical shell, thus requiring outside effort such as a spring or weight to hold the follower roller against the cam surface during the return of the follower. An end cam is shown in Fig. 4.

(p) **DOUBLE END CAM**, in which a projecting twisted thread has been left on a cylindrical body, against both sides of which separate rollers on a follower arm may operate, and thus secure positive motion. Instead of cutting down a cylinder to leave a projecting twisted thread, it may be cast integral with a

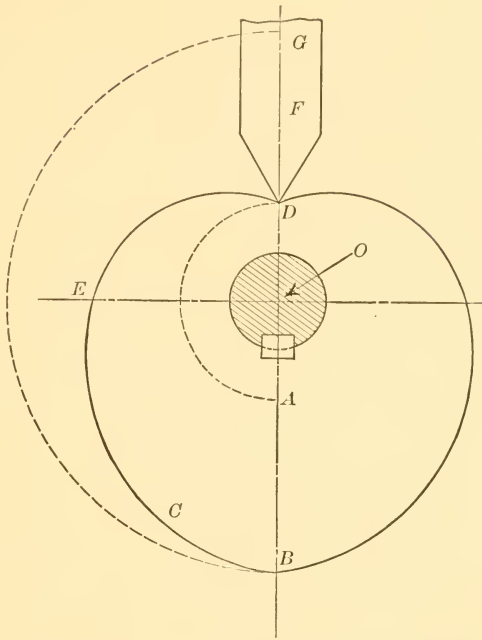

FIG. 7.—HEART CAM AND FOLLOWER, SLIDING CONTACT

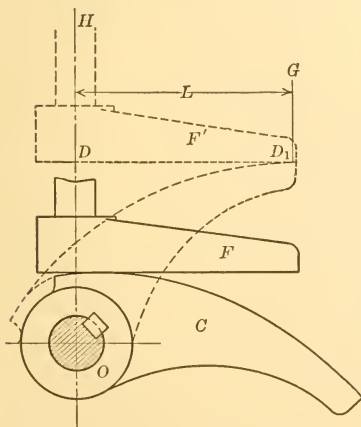

FIG. 8.—TOE AND WIPER CAM

warped plate, as illustrated in Fig. 10, but this in no way changes its characteristic action.

There are a number of names in common use for cams, that cover both radial and side cams. Most prominent in this connection are those mentioned in paragraphs 6 to 14.

6. **BOX CAM**, which designates a cam in which the follower roller is encased between two walls as in the face cam, Fig. 2, or the cylindrical cam, Fig. 3. Literally, box cams would also include yoke cams, in which the yoke would be the "box." Box cams, because of their form of construction, give a positive drive in all cases.

7. **INTERNAL CAM**, in which there is only one working surface, and this is outside of the pitch surface. The internal cam corresponds to the internal gear wheel in toothed gearing. It may also be considered as a face cam with the inside surface of the groove removed, thus requiring that the follower roller should always be in pressure contact on the outside surface of the groove by means of a spring or weight, etc. Under some conditions of structural arrangements of the cam machine, the internal cam may be used to advantage where it will give a positive motion to a follower on the opposite stroke to that of the periphery cam; and it will also sometimes

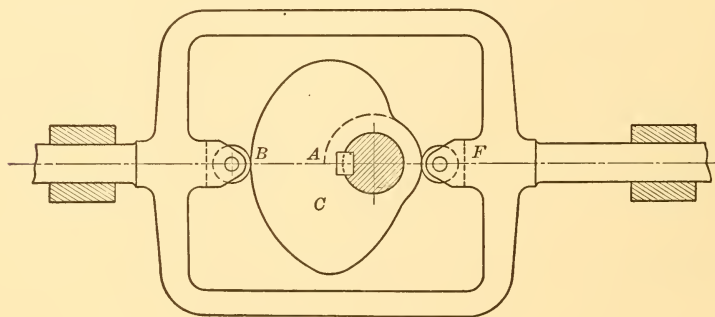

FIG. 9.—YOKE CAM

permit of a larger roller than the periphery cam, as explained in paragraphs 56 and 62.

8. **OFFSET CAM**, in which the line of action of the follower, when extended, does not pass through the center of the cam, see Fig. 43.

9. **POSITIVE-DRIVE CAM** is one in which the cam itself drives the follower on the return as well as the forward motion. Most

cams drive only on the forward motion of the follower and depend upon gravity or the action of a spring to drive the follower in its return motion; such cams are illustrated in Figs. 1, 4, 5, 6, 7, and 8. Cams having positive drive, and therefore independent of gravity or springs, are illustrated in Figs. 2, 3, 9, and 10. It will be noted that positive-drive cams include the face, yoke, cylindrical, and double-end types of cams; also that the box cam, although it includes some of these, should also be considered as a group name of the positive-drive type.

10. SINGLE-ACTING AND DOUBLE-ACTING CAMS comprise all forms of cams, the single-acting ones giving motion only in one direction and depending on a spring or gravity to return the follower. Double-acting cams have the follower under direct control all the time and are the same as positive-drive cams described in the preceding paragraph.

11. STEP CAMS. Cams which give continuous motion to the

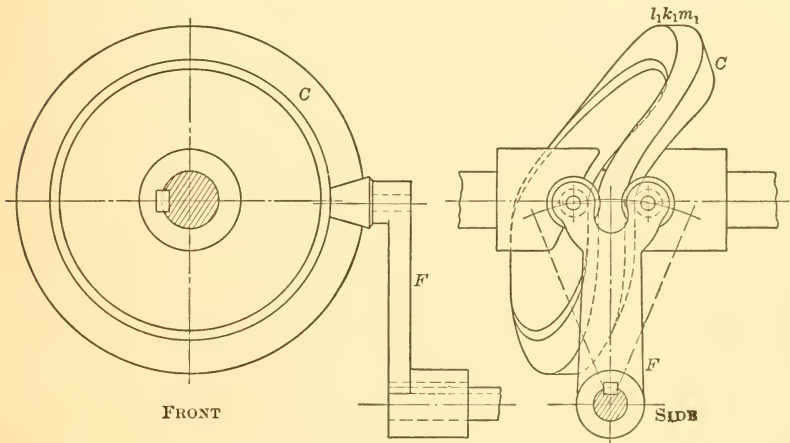

FIG. 10.—DOUBLE-END CAM

follower from one end of the stroke to the other are called single-step cams. When the follower's motion in either of its two general directions is made up of two entirely separate movements it is called a double-step cam with reference to that stroke. If three or more separate movements are given to the follower while it moves in one general direction it is generally referred to as a multiple step cam, or as a triple-step, quadruple-step cam, etc. Since a cam may be, for example, a double-step cam on the out or working stroke, and

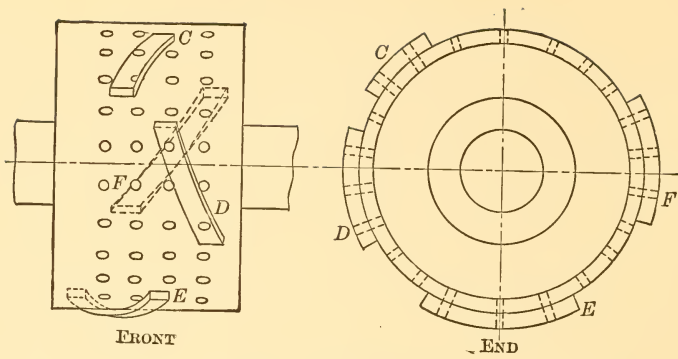

FIG. 11.—BARREL CAM

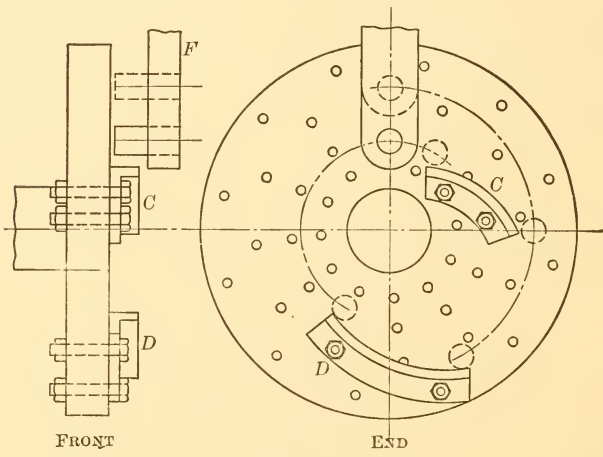

FIG. 12.—ADJUSTABLE PLATE CAM

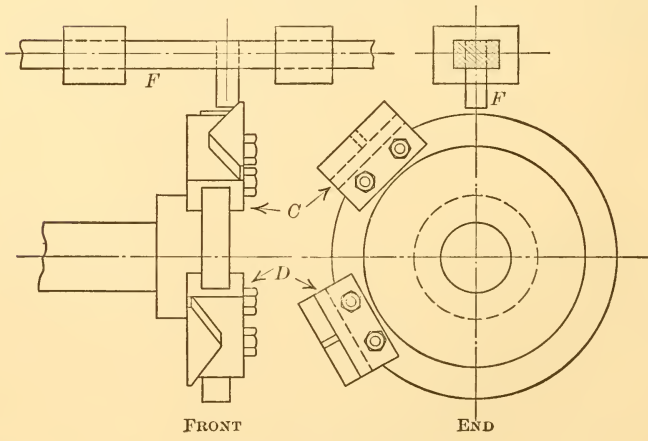

FIG. 13.—DOG CAM

a single-step cam on the return stroke, such a cam may be referred to as a two-one step cam, always giving the number referring to the working stroke first.

12. ADJUSTABLE CAM, ALSO CALLED CLAMP CAM, STRAP CAM, DOG CAM, AND CARRIER CAM, in which specially formed pieces are directly bolted or clamped to any of the regular geometrical surfaces, usually to either the plane or cylindrical surfaces. In Fig. 12 the clamps are shown at *C* and *D* fastened to a disk. The cam, considered as a whole, belongs to the radial class. In Fig. 13 the clamps are shown at *C* and *D*, also fastened to a disk, but in this case the clamps, or dogs, as they are usually called when used in this way, are so formed as to give a sidewise motion to the follower, and therefore this cam belongs to the side cam class. In Fig. 11 clamps are shown at *C*, *D*, *E*, and *F* fastened to a cylinder, and they are shaped to give the same action as a regularly formed end-cam in the side-cam class. The type of cam illustrated in Fig. 11 is also known as an adjustable cylindrical or "barrel" or "drum" cam and is very widely used for regulating the feeding of the stock, and in operating the turret in automatic machines for the manufacture of screws, bolts, ferrules, and small pieces generally that are made up in quantities.

13. DOUBLE-MOUNTED OR MULTIPLE-MOUNTED CAMS are sometimes resorted to where several movements can be concentrated into small space. This consists merely in placing two or more of any of the cam surfaces described in the preceding paragraphs on one solid casting or cam body. For example, a face cam, a cylindrical, and an end cam may all be cut on one piece.

14. OSCILLATING CAMS, in which the cam itself turns through a fraction of a turn instead of through the entire 360° . While any type of cam may be designed to oscillate instead of rotate, it is usually the toe-and-wiper and rolling forms of the radial type of cam that are known as oscillating cams. With oscillating cams the follower may move forth and back on a straight line, or it may oscillate also.

15. Cams falling in the conical class have no special name other than the one here used. The spherical cams are sometimes termed globe cams. Cams in conical and spherical classes are particularly useful in changing direction of motion in close quarters and in directions other than at right angles. In both Figs. 5 and 6, end action of the cam is shown, but it is apparent that with thicker walls on both the cone and the sphere, grooves could be cut in them, thus giving positive driving cams in both cases.

16. Summing up the general and special names for cams we have in tabular form:

| | | | | | |
|------|---|---|---|---|--|
| Cams | } | Box Internal Offset Positive Drive Single Acting Double Acting Step Adjustable or Strap Dog or Carrier Multiple Mounted Oscillating | } | a Radial or Disk b Side, or Cylindrical c Conical d Spherical or Globe | e Periphery f Plate g Heart h Frog i Mushroom j Face or Plate Grooved k Toe and Wiper l Rolling m Yoke or Duplex n Cylindrical, Grooved, Barrel, or Drum o End p Double End |
|------|---|---|---|---|--|

DEFINITIONS OF TERMS USED IN THE SOLUTION OF CAM PROBLEMS

17. CAM CHART. Illustrated in Fig. 14. The chart is a rectangle the height of which is equal to the total motion of the follower in one direction, and the length equal to the circumference of the pitch circle of the cam. The chart length represents 360° and is sub-

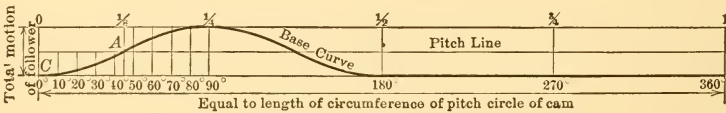

FIG. 14.—CAM CHART

divided into equal parts marking the 5°, 10° . . . points, or the 1/8, 1/4 . . . points, or any other convenient subdivision, according to the requirements of the problem. On the cam chart are drawn the base curve and the pitch line. The former becomes the pitch surface of the cam and the latter the pitch circle.

18. CAM CHART DIAGRAM. Illustrated in Fig. 15. The cam chart diagram is a rectangle, the height of which represents the total motion of the follower in one direction. The length of the diagram represents the circumference of the pitch circle of the cam.

In the cam chart diagram the scales for drawing the height and the length of the rectangle are totally independent of each other and independent also of the scale of the cam drawing. In drawing the diagram no scale need be used at all, and the entire chart diagram with its base curve and pitch line may be drawn entirely freehand with suitable subdivisions marked off entirely "by eye" according to the requirements of the problem. The base curve may be drawn roughly as a curve or it may be made up of a series of straight lines. The cam chart diagram frequently serves all the purposes of the cam chart. It saves time, and permits of chart drawings being

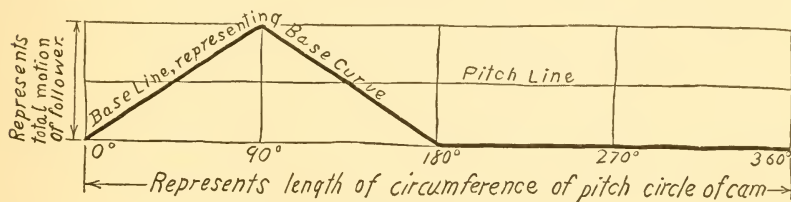

FIG. 15.—CAM CHART DIAGRAM

made on small available sheets of paper, whereas the more precise cam chart often requires large sheets of paper which are usually impracticable and unnecessary in many circumstances.

19. TIME CHARTS. Illustrated in Figs. 16 and 17. Time charts are the same as cam charts or cam chart diagrams, and are constructed in the same way as described in the two preceding paragraphs. The term "time chart," however, is most appropriately applied to problems where two or more cams are used in the same machine and where their functions are dependent on each other.

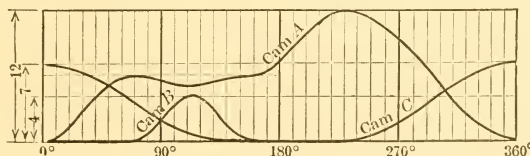

FIG. 16.—TIME CHART DIAGRAM, BASE CURVES SUPERPOSED

The time chart permits of allowances being made for avoiding possible interference of the several moving parts, and for the desired timing of relative motions for each part. The time chart contains two or more base curves according to the number of cams used. When the base curves are superposed as in Fig. 16, the time chart consists of a single rectangle whose height is equal to the greatest

follower motion. The superposing of curves and lines often leads to confusion and error, and it is better, in general, that the time chart should consist of a series of charts or rectangles all of the same length and one directly under the other as in Fig. 17. Where there are many base curves it is desirable to separate the rectangles

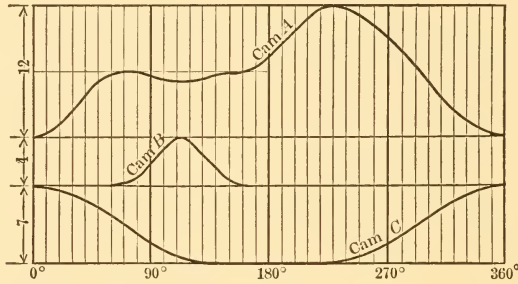

FIG. 17.—TIME CHART DIAGRAM, BASE CURVES SEPARATED

by a small space to avoid any possibility of confusion due to different base curves running together. In many cases the term "time chart diagram," or "timing diagram," will be more appropriate than "time chart" in just the same way as the cam chart diagram is more appropriate than the cam chart.

20. **BASE CURVE.** Illustrated in Fig. 14. A base curve is made up of a series of smooth continuous curves, or a combination of curves and straight lines, which represent the motion of the follower, and which run in a wave-like form across the entire length of the cam chart or diagram. The base curve of the cam chart becomes the *pitch surface* of the cam.

21. **BASE LINE.** Illustrated in Fig. 15. A base line is made up of a series of inclined straight lines, or a series of inclined and horizontal lines, in consecutive order, which zigzag across the entire length of the chart. The base line when used on the *cam chart* indicates the exact motion of the follower, but when used on a *cam chart diagram* it is merely a time-saving substitute for the drawing of the base curve. The base line of the cam chart diagram represents the pitch surface of the cam.

22. **NAMES OF BASE CURVES OR BASE LINES IN COMMON USE,** see Figs. 18 and 19:

- | | |
|------------------------------|----------------------|
| 1. Straight line | 4. Parabola. |
| 2. Straight-line combination | 5. Elliptical curve. |
| 3. Crank curve. | |

23. PITCH LINE. Illustrated in Fig. 14. A pitch line is a horizontal line drawn on the cam chart or diagram, and it becomes the *pitch circle* of the cam. The position, or elevation, of the pitch line on the chart varies according to the base curve which is specified, and according to the data of the problem. For cams which give a

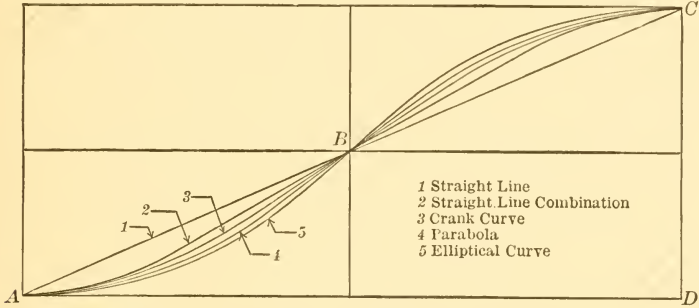

FIG. 18.—COMPARISON OF BASE CURVES IN COMMON USE SHOWING VARYING DEGREES OF MAXIMUM SLOPE WHEN DRAWN IN SAME CHART LENGTH

continuous motion to the follower during its entire stroke, or throw, the pitch line will pass through the point on the base curve which has the greatest slope, starting from the bottom of the chart. This does not apply to all possible base curves, but it does apply to all

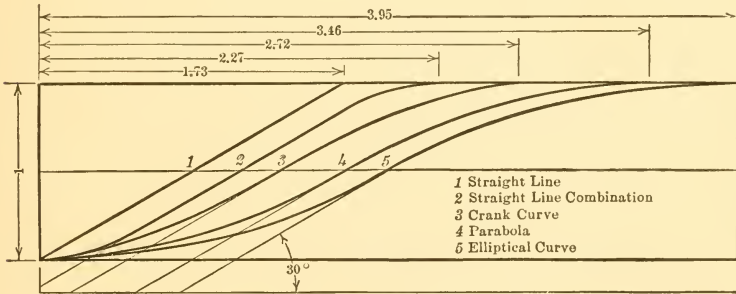

FIG. 19.—COMPARISON OF BASE CURVES IN COMMON USE SHOWING UNIFORM MAXIMUM SLOPE OF 30° WHEN DRAWN IN CHARTS OF VARYING LENGTH

those mentioned in the preceding paragraph, a minor exception being made of the crank curve which will be referred to in paragraph 34. When the cam causes the follower to move through its total stroke in two or more separate steps the position of the pitch line on the chart must be specially found as will be explained in problem 5.

24. **PITCH CIRCLE.** Illustrated in Fig. 20. A pitch circle is drawn with the center of rotation of the cam as a center, and its circumference is equal to the cam chart length. Its characteristic is that it passes through that point *A*, Fig. 20, of the *pitch surface* of the cam where the cam has its greatest side pressure against the follower. This applies to all cams in which the center of the follower roller moves in a straight radial line. For other motions of the follower roller, and for flat-faced followers, the pitch circle must be specially considered, as will be explained in some of the problems covering these types.

25. **PITCH SURFACE.** Illustrated in Fig. 20. The pitch surface of a cam is the theoretical boundary of the cam that is first laid down in constructing the cam. When the follower has a V-shaped edge, as at *D* in Fig. 7, the pitch surface coincides with the *working surface* of the cam. When the follower has roller contact, as in Fig. 20, the pitch surface passes through the axis of the roller and the working or actual surface of the cam is *parallel* to the pitch surface and a distance from it equal to the radius of the roller.

26. **WORKING SURFACE.** Illustrated in Fig. 20. The working surface of the cam is the surface with which the follower is in actual contact. It limits the working size and weight of cam. For exact compliance with a given set of cam data, the cam has only one theoretical size which is bounded by the pitch surface, but the working size may be anything within wide limits which depend on the radius of the follower roller and the necessary diameter of the cam shaft.

The working surface is found by taking a compass set to the radius of the roller and striking a series of arcs whose centers are on the pitch surface. Such a series of arcs is shown in Fig. 20 with their centers at *B*, *A*, etc. The curve which is an envelope to these arcs is the working surface.

27. **PITCH POINT OF FOLLOWER.** Illustrated in Fig. 20. The pitch point of the follower is that point fixed on the follower rod or arm which is always in theoretical contact with the pitch surface of the cam. If the follower has a sharp V-edge the pitch point is the edge itself. If the follower has a roller end, the pitch point is the axis of the roller. The pitch point is constantly changing its position from *C* to *D* as the follower moves up and down.

28. **PRESSURE ANGLE.** Illustrated in Fig. 20. The pressure angle is the angle whose vertex is at the pitch point of the follower in its successive positions and whose sides are the direction

of motion of the pitch point and the normal to the pitch surface.

Pressure angles exist when the surface of the cam presses sidewise against the follower; they cause bending in the follower arm and side pressure in the follower guide and in the bearings. The pres-

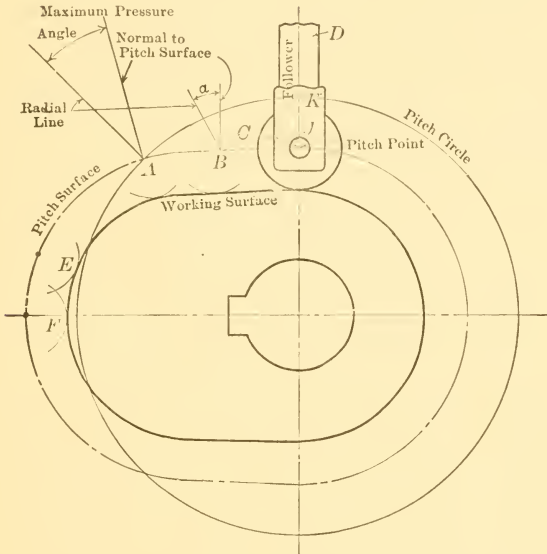

FIG. 20.—SHOWING NAMES OF SURFACES, LINES, AND POINTS OF A CAM

sure angle is constantly varying in all cams as the follower moves up and down, except where a logarithmic spiral is used. In assigning cam problems the maximum permissible pressure angle is usually given. In Fig. 20 the pressure angle is zero at *C*, it will be equal to *a* when *B* reaches *J*, and will be a maximum when *A* reaches *K*.

29. FORMULA FOR SIZE OF CAM FOR A GIVEN MAXIMUM PRESSURE ANGLE. The radius of the pitch circle of the cam may be found directly by the formula:

$$\begin{aligned}
 r &= h \times \frac{360}{b} \times f \times \frac{1}{2\pi} \\
 &= 57.3 \frac{hf}{b} \dots \dots \dots (1)
 \end{aligned}$$

or,

$$\begin{aligned}
 r &= h \times \frac{1}{e} \times f \times \frac{1}{2\pi} \\
 &= .159 \frac{hf}{e} \dots \dots \dots (2)
 \end{aligned}$$

in which, r = radius of pitch circle of cam.

h = distance traveled by follower.

f = factor for a given maximum pressure angle.

b = angle, in degrees, turned by cam while follower moves distance h .

e = angle, in fraction of revolution, turned by cam while follower moves distance h .

30. CAM FACTORS FOR MAXIMUM PRESSURE ANGLE. The factors, or value of f , for various maximum pressure angles for cams using the several base curves in common use are:

TABLE OF CAM FACTORS

| Name of Base Curve | MAXIMUM PRESSURE ANGLE AND VALUES OF f | | | | |
|-------------------------------|--|------|------|------|------|
| | 20° | 30° | 40° | 50° | 60° |
| Straight line..... | 2.75 | 1.73 | 1.19 | .84 | .58 |
| Straight-line combination*... | 3.10 | 2.27 | 1.92 | 1.77 | 1.73 |
| Crank curve..... | 4.32 | 2.72 | 1.87 | 1.32 | .91 |
| Parabola..... | 5.50 | 3.46 | 2.38 | 1.68 | 1.15 |
| Elliptical curve†..... | 6.25 | 3.95 | 2.75 | 1.95 | 1.35 |

These factors, for 30°, are illustrated in Fig. 19 where each of the base curves is given such a length, in terms of the height, that they will all have the same maximum slope. The values given in this table are also shown, graphically, in Fig. 21, thus enabling one to find the proper cam factor for any intermediate pressure angle between 20° and 60°.

* For case where easing off radius equals follower's motion.

† For case where ratio of horizontal to vertical axes of ellipse is 7 to 4.

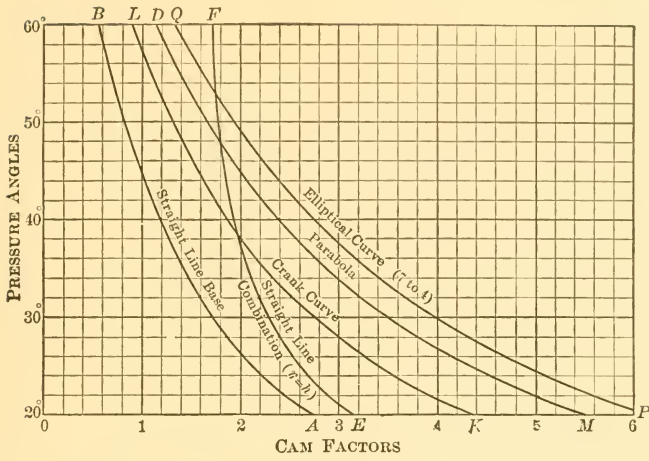

FIG. 21.—CHART SHOWING RELATION BETWEEN PRESSURE ANGLES AND CAM FACTORS FOR THE ORDINARY BASE CURVES

SECTION II.—METHOD OF CONSTRUCTION OF BASE CURVES IN COMMON USE

31. **DETAIL CONSTRUCTION OF BASE CURVES.** The method of constructing the several base curves for a rise of one unit of the follower will be explained in the succeeding paragraphs. The curves will be constructed to give a pressure angle of 30° by selecting factors from the 30° column in the table in the preceding paragraph. Should the base curve for any other pressure angle be desired the factor should be taken from the corresponding column.

32. **STRAIGHT-LINE BASE.** Fig. 22. Lay off AB equal to the follower motion, which will be taken as 1 unit in these illustrations. Multiply this by the factor 1.73 from paragraph 30, and lay off the distance AR equal to it. Complete the parallelogram and draw the diagonal. This will be the straight line base and the

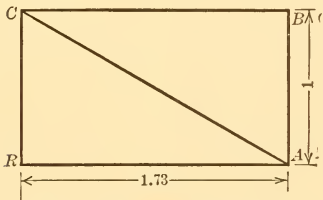

FIG. 22.—STRAIGHT BASE LINE

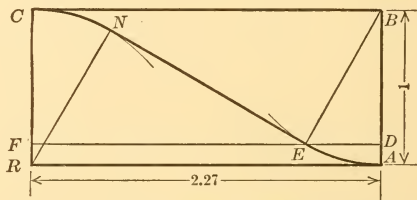

FIG. 23.—STRAIGHT-LINE COMBINATION CURVE

angle RAC will be 30° . AR will be the pitch line. These base lines and curves are laid off from right to left so that they may be used in a natural manner later on in laying out the cam so that it will turn in a right-handed or clockwise direction.

The straight-line base gives abrupt starting and stopping velocities at the beginning and end of the stroke and causes actual shock in the follower arm. The velocity of the follower during the stroke is constant. The acceleration at starting and retardation at stopping is infinite and is zero during the stroke.

33. **STRAIGHT-LINE COMBINATION CURVE.** Fig. 23. Construct the rectangle with a height of 1 unit and a length of 2.27 units. With B and R as centers draw the arcs AE and CN , and draw a straight line EN tangent to them. The angle REN will then equal 30° and the line AC will be a base curve made up of arcs and a

straight line combined to form a smooth curve. DF will be the pitch line.

The straight-line combination curve, being rounded off at the ends, does not give actual shock to the follower at starting and stopping, but it does give a more sudden action than any of the base curves which follow, and the maximum acceleration and retardation values are comparatively larger.

34. CRANK CURVE. Fig. 24. Construct the rectangle. Draw the semicircle RCG and divide it into any number of equal parts. Six parts are best for practice work for this curve, but in general in practical work the greater the number of divisions the more accurate will be the curve and the smoother the action of the cam.

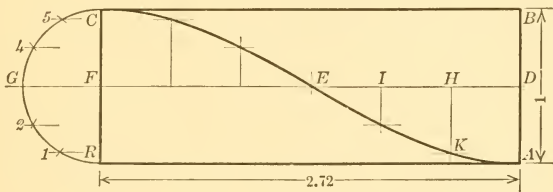

FIG. 24.—CRANK CURVE

The six equal divisions of the semicircle are readily obtained by taking G as a center and FC as a radius and striking arcs at 1 and 5, then with R and C as centers mark the points 2 and 4 respectively. Divide the length of the chart into six equal parts, as at H, I, E , etc. From these points drop vertical lines, and from the corresponding divisions on the semicircle draw horizontal lines, giving intersecting points, as at K , on the desired crank curve. The tangent to the curve at E will then make an angle of 30° with the line EF . The pitch line will be DF .

When the crank curve is transferred from the chart to the cam it gives an angle which is a fraction of a degree greater than 30° at the point E on the cam in practical cases. This is not enough greater to warrant the special computations and drawing that would be necessary to be exact. Therefore the method of laying out the crank curve and the pitch line, as given above, will be adhered to in this elementary consideration of cam work, because of its simplicity.

The crank curve gives a slightly irregular increasing velocity to the follower from the beginning to the middle of its stroke; then a decreasing velocity in reverse order to the end of the stroke. The

acceleration diminishes to zero at the middle of the stroke and then increases to the end. The maximum acceleration and retardation values are much less than for the straight-line combination curve, and are only a little greater than for the parabola.

35. PARABOLA. Fig. 25. Construct the rectangle. Draw the straight line RS in any direction and lay off on it sixteen equal divisions to any scale. From the sixteenth division draw a line to F , the middle point of the chart; draw other lines parallel to this through the points 9, 4, and 1, thus dividing the distance RF into four unequal parts which are to each other, in order, as 1, 3, 5, and 7. From these division points draw horizontal lines, and from H , I , and J drop vertical lines. The intersecting points, as at K ,

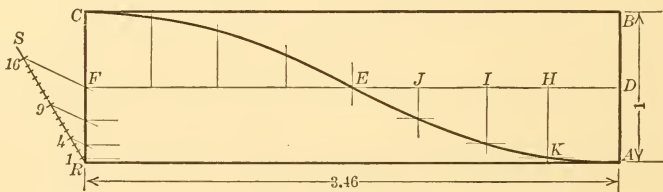

FIG. 25.—PARABOLA

will be on the desired parabola. The points H , I , and J divide the distance DE into four equal parts.

The parabola gives a uniformly increasing velocity from the beginning to the middle of the stroke; then a uniformly decreasing velocity to the end. The acceleration of the follower is constant during the first half of the stroke and the retardation is constant during the last half. The acceleration and retardation values are equal and are less than the maximum value of any of the other base curves. This means that the direct effort required to turn a positive-acting parabola cam is less than for any other type of positive cam.

36. To better understand the smooth action given by the cam using this curve, consider, 1st, DH as a time unit during which the follower rises one space unit; 2d, HI as an equal time unit during which the follower rises three space units; 3d, IJ as the time unit during which the follower rises five space units, etc. Inasmuch as the follower travels two units further in each succeeding time unit, it gains a velocity of two units in each time unit, and this is uniform acceleration.

The distance from F to C would be divided the same as from F to R and points on the part of the curve from E to C similarly

located. This curve will be identical with $E A$, but in reverse order, and will give uniform retardation. The tangent to the curve $A C$ at the point E will make an angle of 30° with $E F$, and $D F$ will be the pitch line.

Eight construction points were taken in developing the curve $A C$. Eight points will be sufficient for beginners for practice work

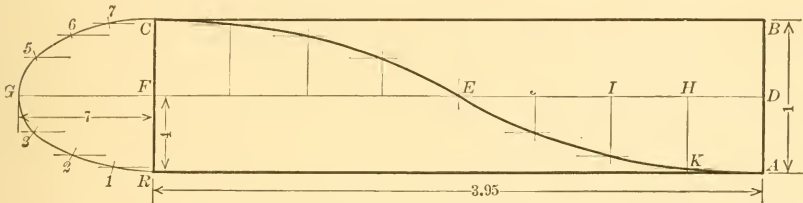

FIG. 26.—ELLIPTICAL CURVE

and later six points may be used. When using six points only nine equal divisions should be laid out on the line $R S$, the remaining construction being the same as described above, except that $D E$ should be divided into three parts instead of four. In practical work many more construction points should be used for accuracy and smooth cam action.

37. ELLIPTICAL CURVE. Fig. 26. Draw rectangle $A B C R$. Draw semi-ellipse making $F G$ equal to $\frac{7}{4} F C$. To draw the ellipse, take a strip of paper with a straight edge and mark fine lines at P , T , and S , Fig. 26a, making $P T = C F$ and $P S = G F$. Move the strip of paper so that S will always be on the line $R C$, and T on the line $F G$; P will then describe the path of the ellipse. Having the semi-ellipse, divide the part $R G$, Fig. 26, into four equal arcs as at 1, 2, 3. This is quickest done by setting the small dividers to a small space of any value and stepping off the distance from R to G . Suppose that there are 18.8 steps. Set down this number and divide it into four parts, giving 4.7, 9.4, and 14.1. Then again step off the arc from R to G with the same setting of the dividers, marking the points that are at 4.7, 9.4, and 14.1 steps. The compass setting being small, the fractional part of it can be estimated with all practical precision. Divide $D E$ into four equal parts as at H , I , J . Draw vertical lines from these points and horizontal lines from the

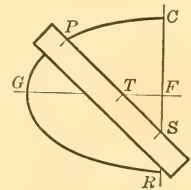

FIG. 26a.—SHOWING METHOD OF DRAWING SEMI-ELLIPSE

corresponding points at 1, 2, and 3. The intersections, as at K , will give a series of points on the elliptical base curve. The curve EC is similar to AE but in reverse order. The tangent to the curve at E makes an angle of 30° with EF , and DF is the pitch line.

The elliptical base curve gives slower starting and stopping velocities to the follower than any of the other curves, but the velocity is higher at the center of the stroke. The acceleration is variable and increases to the middle of the stroke, where its maximum value is greater than that of the crank curve but less than that of the straight-line combination curve. The retardation values decrease in reverse order to the end of the stroke.

F, Fig. 27, as the rod moves up. In order that these things may be known, this preliminary problem will now be redrawn with additional specifications.

41. PROBLEM 2. TECHNICAL DESIGN. Required a radial cam that will operate a roller follower:

- (a) Up 3 units while the cam turns 90°.
- (b) Down 2 " " " " " 60°.
- (c) Dwell " " " " " 120°.
- (d) Down 1 unit " " " " " 90°.

(e) The follower, in all its motions, shall move with uniform acceleration and uniform retardation.

(f) The maximum side pressure of the cam against the follower rod shall be 40°.

Items (a), (b), (c), and (d) are the same as in Problem 1.

42. Inasmuch as this problem is given at this place simply to show that velocity and acceleration and side pressure can always be controlled with very little additional labor beyond that necessary for the simple layout shown in Fig. 28, the full explanations of the formula and figures used will not be given here. They will be taken up in their proper order in subsequent paragraphs. For this problem the only necessary computation is:

$$r = 57.3 \frac{hf}{b} = 57.3 \frac{3 \times 2.38}{90} = 4.55 = \text{Radius of pitch circle} =$$

CH, Fig. 29.

The reference letters, *h*, *f*, and *b* are defined in paragraph 29. Lay off *CH* in Fig. 29, and then lay off the follower motion of 3 units equally distributed on each side of *H*, as at *HB* and *HD*. Divide *DH* into nine equal parts and take the first, fourth, and ninth parts; do likewise with *BH*. Divide the 90° angle *BCD*₁ into six equal parts by radial lines as shown, and swing each of the six division points between *D* and *B* around until they meet successively the six radial lines.

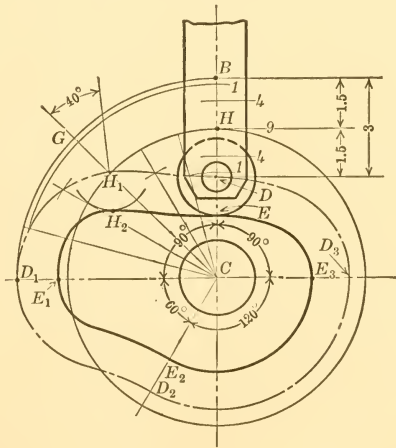

FIG. 29.—TECHNICAL DESIGN OF CAM FOR DATA IN PROBLEM 2, DRAWN TO SAME SCALE AS FIG. 28

A curve through the intersecting points will be the pitch surface of the cam, as shown by the dash-and-dot curve $D H_1 D_1 . . .$

The working surface will be $E E_1 . . .$ which is found as described in paragraph 26.

The pitch surface $D_1 D_2$ is obtained in the same way as $D D_1$ was found. The curve $D_2 D_3$ is an arc of a circle, and the curve $D_3 D$ is found in the same manner as $D D_1$.

43. ADVANTAGES OF THE TECHNICAL DESIGN. With the cam constructed as above the follower will start to move with the same characteristic motion as has a falling body starting from rest, and the follower will be stopped with the same gentle motion in reverse order. It

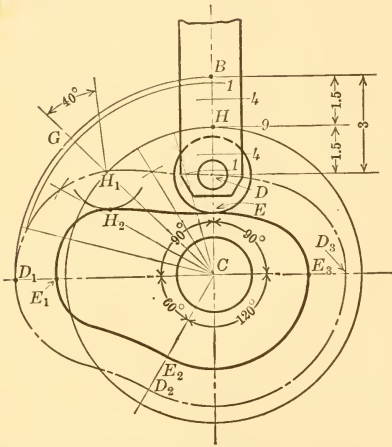

FIG. 29.—(Duplicate) TECHNICAL DESIGN OF CAM FOR DATA IN PROBLEM 2, DRAWN TO SAME SCALE AS FIG. 28

will be definitely known also that the greatest side pressure of the cam against the follower is at an angle of 40° as specified, and that this pressure will occur when H_1 of the pitch surface of the cam is at H , or when the roller is in contact with the working surface at H_2 . Where the cam form is assumed as in Fig. 28, nothing is known positively of the starting and stopping velocities of the follower. Further, as may be found by trial, the maximum angle of pressure of the cam against the rod runs up to 47° in Fig. 28, as shown at D_4 . The minimum radius of the cam in Fig. 28 was taken equal to that in Fig. 29 for comparison.

44. The two previous problems have been given as brief exercises without going into all the detail necessary to a full understanding, in order to give an idea of the method of producing cams on a scientific basis. In the problems which will follow, the several steps in building cams of various types will be explained. In many of the problems the same data will be used so that comparisons of different forms of cams which produce the same results may be made.

45. PROBLEM 3. SINGLE-STEP RADIAL CAM, PRESSURE ANGLE EQUAL ON BOTH STROKES. Required a single-step radial cam in which the center of the follower roller moves in a radial line. The maximum pressure angle to be 30° , and the follower to move:

- (a) Up 3 units in 90° with uniform acceleration and retardation.
 (b) Down 3 units in 90° with uniform acceleration and retardation.
 (c) At rest for 180° ?

46. The first step in the solution is to determine the total length of the cam chart for a parabola chart curve and for a 30° maximum pressure angle. From the table, paragraph 30, the factor for this case is found to be 3.46. Since the travel of the follower is 3 units in $\frac{1}{4}$ revolution, the total length of chart will be $3 \times 3.46 \times 4 = 41.52$, which, therefore, is the length of the chart $A A'$ in Fig. 30. This length represents the 360° of the cam. Lay off $A W$ equal to 90° , according to item (a) in the data. Construct the parabolic curve $A E C$. Completing the entire chart, the base curve is found to be $A C M N A'$. The next step is to find the radius of the pitch circle. The circumference of this circle is equal to the length of the pitch line $D D'$. Its radius is, therefore, equal to $\frac{41.52}{2\pi} = 6.61$, and this value is laid off at $O D$, Fig. 31, and the pitch circle $D F Q W$ drawn. The quadrant $D F$ is divided into the same number of parts as $D F$ in Fig. 30. The vertical construction lines $H H_1, I I_1, J J_1 \dots$ in Fig. 30 now become the radial lines correspondingly lettered in Fig. 31, and the pitch surface is drawn through the points $A H_1 I_1 J_1 \dots$. The positions of maximum pressure are shown at E and Q ; at all other points it will be less. The working surface $B G R P$ is found by assuming a radius $A B$ for the roller, and by striking a series of arcs as shown at $H_2, I_2, J_2 \dots$ with the points $H_1, I_1, J_1 \dots$ as centers, and then drawing the working curve tangent to these arcs. With the same specifications for the up and down motions of the follower, as given by items (a) and (b) in the data, this type of cam will be symmetrical about the line $Y C$.

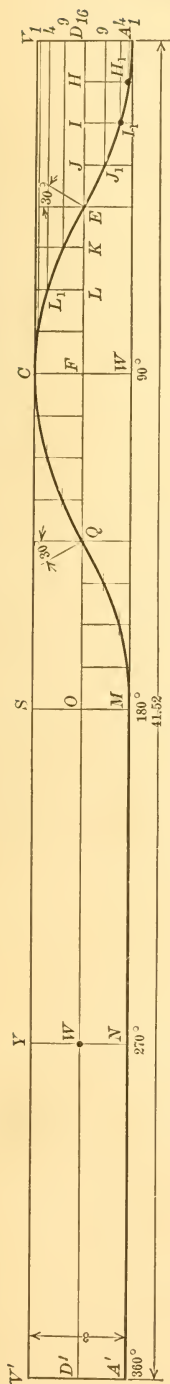

FIG. 30.—PROBLEM 3, CAM CHART

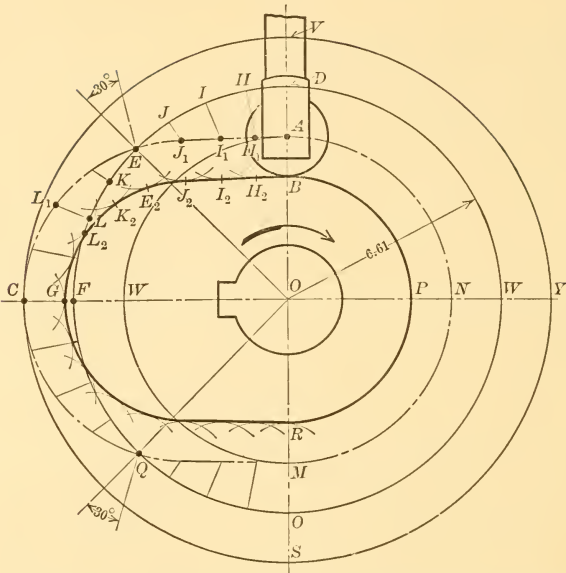

FIG. 31.—PROBLEM 3, CAM LAID OUT FROM CAM CHART

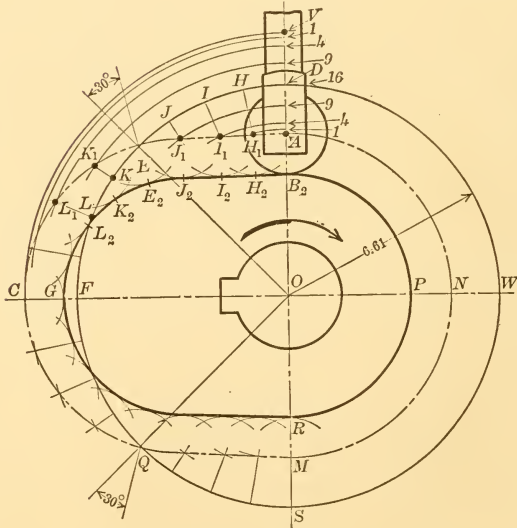

FIG. 32.—PROBLEM 3, CAM LAID OUT INDEPENDENTLY OF CAM CHART

47. OMISSION OF CAM CHART. When the relation between pressure angle, chart base and pitch lines, and cam pitch and surface lines is understood and fixed in mind, the actual drawing of the chart for the graphical construction of simple cams and particularly of single-step cams may be omitted with full confidence when the elementary base curves are used. For example, the problem in the previous paragraph is shown completely worked out in Fig. 32 without any reference whatever to the chart of Fig. 30. The radius OD of the pitch circle, Fig. 32, is obtained directly from the formula,

$r = 57.3 \frac{h f}{b}$ given in paragraph 29. Substituting the data as given in the previous paragraph, $r = 57.3 \frac{3 \times 3.46}{90} = 6.61$ and is laid off

at DO . The assigned motion of the follower is laid off symmetrically on both sides of the pitch point D , as at AV , and the distances AD and VD are divided into the desired number of unequal parts, as at 1, 4, 9, 16. The quadrant DF is divided into the same number of equal parts as at $H, I, J \dots$ and indefinite radial construction lines drawn through the points. Circular construction arcs are next drawn through the points 1, 4, 9 \dots until they intersect the radial lines, thus obtaining points $H_1, I_1, J_1 \dots$ on the cam pitch surface. In general, a neater construction is obtained by omitting the full length of the construction arcs, as from V to $C \dots$ and simply drawing short portions of the arc at the intersecting radial lines as shown in the lower left-hand quadrant between C and M .

48. EXERCISE PROBLEM 3a. Required a single-step radial cam in which the center of the follower roller moves in a radial line. The maximum pressure angle to be 40° , and the follower to move:

- (a) Out 6 units in 135° on the crank curve.
- (b) In 6 " " 135° " " " "
- (c) At rest for 90° .

49. PROBLEM 4. SINGLE-STEP RADIAL CAM, PRESSURE ANGLES UNEQUAL ON THE TWO STROKES. Required a single-step radial cam in which the center of the follower moves in a radial line. The maximum pressure angle not to exceed 30° on the outstroke nor 50° on the return stroke, and the follower to move:

- (a) Out 2 units in $\frac{5}{16}$ revolution on the crank curve.
- (b) In 2 " " $\frac{3}{16}$ " " " " "
- (c) At rest for $\frac{1}{2}$ revolution.

50. The diameter of pitch circle of the cam that will be necessary to fulfil the requirements on the outstroke will be:

$$d_a = \frac{2 \times 2.72 \times 16}{3.14 \times 5} = 5.54 \text{ units, or from formula paragraph 29.}$$

$$r = .159 \frac{2 \times 2.72 \times 16}{5} = 2.77,$$

and the diameter of pitch circle required for the instroke will be

$$d_b = \frac{2 \times 1.32 \times 16}{3.14 \times 3} = 4.48 \text{ units.}$$

Inasmuch as there can be only one pitch circle for a cam, the largest one resulting from the several specifications must be used. In this problem then the diameter SD of the pitch circle in Fig. 33

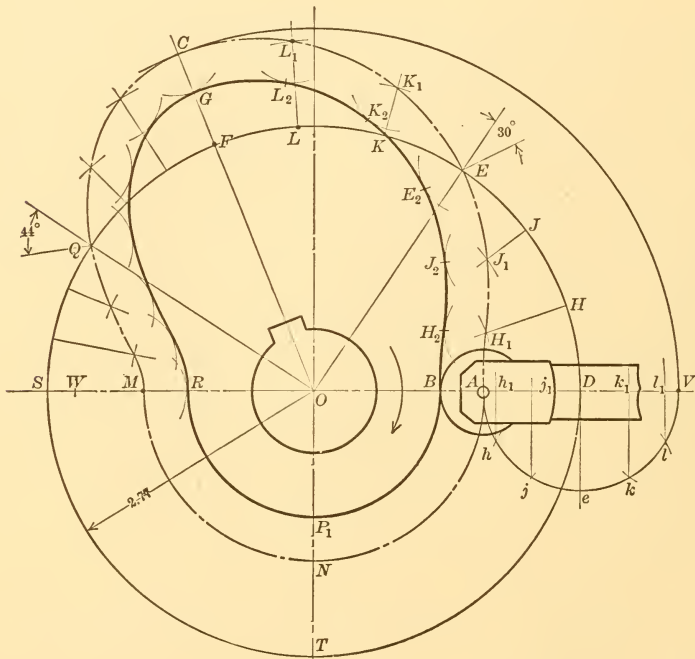

FIG. 33.—PROBLEM 4, MAXIMUM PRESSURE ANGLE DIFFERENT ON THE TWO STROKES

equals 5.54 units. The follower's motion of two units is laid out at AV and the pitch surface $AECMN$ constructed. The working surface of the cam BKG , etc., is then drawn. Since a larger diameter of pitch circle had to be used for the return stroke than the require-

ments called for, it follows that the pressure angle will not reach 50° on that stroke, and it may be of some interest to determine what the maximum pressure angle on the return stroke will be. Substituting the diameter used, 5.54, in the formula $d = \frac{hf}{\pi e}$ and solving for f , f is found to be equal to 1.63. From the chart in Fig. 21 it is shown that a factor of 1.63 for the crank curve corresponds to a maximum pressure angle of nearly 44° , and this angle may be drawn in its proper position at Q in Fig. 33.

51. EXERCISE PROBLEM 4a. Required a single-step radial cam in which the center of the follower roller moves in a radial line. The maximum pressure not to exceed 30° on the up stroke nor 40° on the down stroke, and the follower to move:

- (a) Up 3 units in 135° on the parabola curve.
- (b) At rest for 45° .
- (c) Down 3 units in 90° on the parabola curve.
- (d) At rest for 90° .

52. PRESSURE ANGLE INCREASES AS PITCH SIZE OF CAM DECREASES.

This is illustrated in Fig. 34, where the large pitch cam represented by $D, D_2 \dots$ gives exactly the same motion to a follower as the small pitch cam $d, d_2 \dots$. It will be noted that the pressure angle for the large cam, at the start, is $H D G$, while for the small cam it is increased to $h d g$. Likewise the maximum pressure angle for the large cam, when the follower is near the end of its stroke, is b_1 , while for the small cam the maximum pressure angle is b , which is larger than b_1 . From these observations it may be said, in general, that the larger the *pitch* surface of the cam the smaller will be the pressure angle. The size of the roller has no effect whatever on the pressure angle. Two cams of the same *pitch* size may be of totally different *actual* sizes for the same work, one cam having a large roller and the other a small roller. Therefore it is important to remember that, in general, the pressure angle may be regulated by changing the size of the *pitch* surface only and not the working surface.

53. CHANGE OF PRESSURE ANGLE IN PASSING FROM CHART TO CAM. The circumference of the pitch circle of the cam, it will be recalled, is equal to the length of the pitch line on the chart. It will also be remembered that the pitch line may be at various heights on the chart, paragraph 23. It is now important to consider:

1st. That the pressure angle at the pitch circle on the cam must be the same as the pressure angle at the pitch line on the chart.

2d. That the pressure angle at any point on the pitch surface of the cam outside of the pitch circle will be less than the pressure angle of the corresponding point on the base curve of the cam chart.

3d. That the pressure angle at any point on the pitch surface

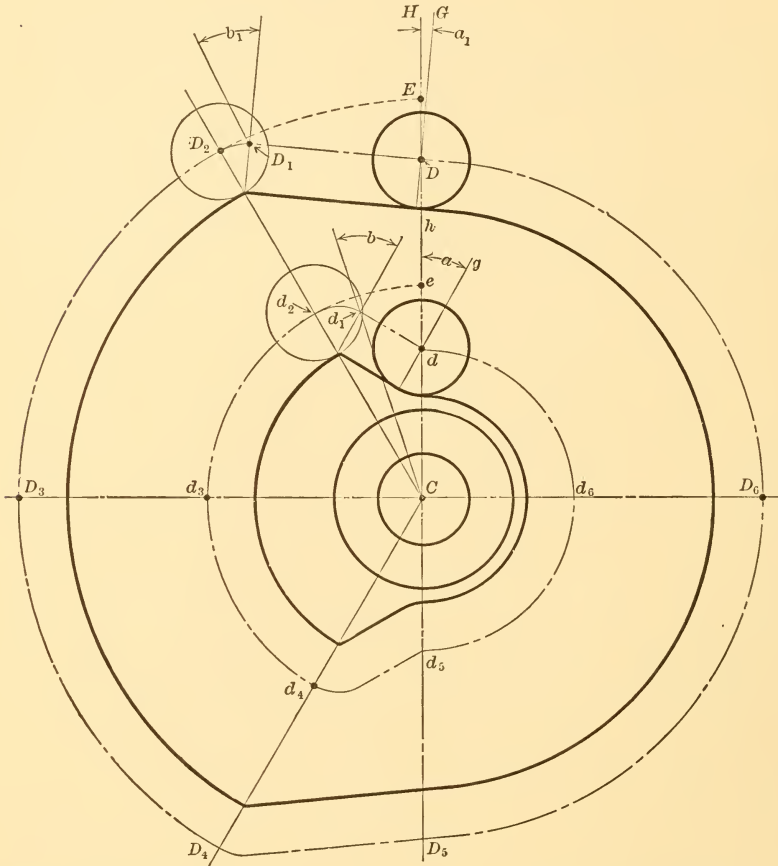

FIG. 34.—SHOWING RELATION BETWEEN PRESSURE ANGLE AND SIZE OF PITCH CAM

of the cam inside of the pitch circle will be greater than the pressure angle of the corresponding point on the base curve of the cam chart.

These statements, which are theoretically true for nearly all cases, and practically so for all other cases where the usual base curves are employed, are demonstrated in the following paragraph.

54. CAM CONSIDERED AS A BENT CHART. Consider that the cam itself is the cam chart bent in its own plane so that the pitch line

becomes the pitch circle. Then the line DD' , Fig. 30, becomes the circle $DFOW$, Fig. 31; the line VV' is stretched to become the circle $VC SY$, and the straight line $AM A'$ is compressed to become the circle $AM A$. This means, in a general way, that the rectangle $DVV'D'$, Fig. 30, is so distorted that if an original diagonal had been drawn from D to V' it would have an increased length and a decreasing slant after the bending had taken place. With a decreasing slant of the pitch surface the pressure angle will decrease. Likewise, a diagonal drawn from D' to A in the original rectangular chart would be decreased in length and would have an increasing slant, and the pressure angle would be increasing toward A . This is illustrated in detail in Figs. 35 and 36.

55. BASE LINE ANGLES, BEFORE AND AFTER BENDING. The pressure angle of 30° at E in Fig. 35 is reduced to 23° in Fig. 36, and the

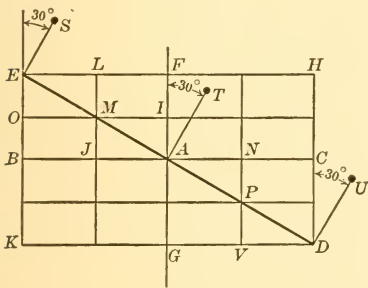

FIG. 35.—SECTION OF CAM CHART BEFORE BENDING

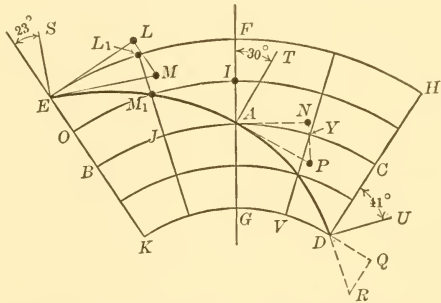

FIG. 36.—SECTION OF CAM CHART AFTER BENDING, BC CONSTANT IN BOTH FIGURES

30° at D are increased to 41° . Fig. 35 represents a cam chart with a straight base line DE , and Fig. 36 is a corresponding cam sector with DE as the pitch surface. If BC , Fig. 35, is taken as the pitch line, BC , Fig. 36, will be part of the pitch circle. The uniform pressure angle of 30° from A to E , Fig. 35, will grow smaller beyond A in Fig. 36 for the reason that the radial components of the tangential triangles remain constant, as illustrated at LM , while the tangential components grow longer as illustrated from AN to EL , which are respectively equal to the arcs AY and EL_1 . Consequently, the angles grow smaller from the angle NAP to LEM . Similarly it may be shown that they grow larger from NAP to QDR .

56. LIMITING SIZE OF FOLLOWER ROLLER. The radius of the follower roller may be equal to, but in general should be less than

the shortest radius of curvature of the pitch surface, when measured on the working-surface side. If the radius of the roller is not so taken, the follower, when put in service, will not have the motion for which it was designed.

57. CASE 1. RADIUS OF ROLLER EQUAL TO RADIUS OF CURVATURE OF PITCH CAM. In Fig. 37, $A B E F A$ is the pitch surface of a cam.

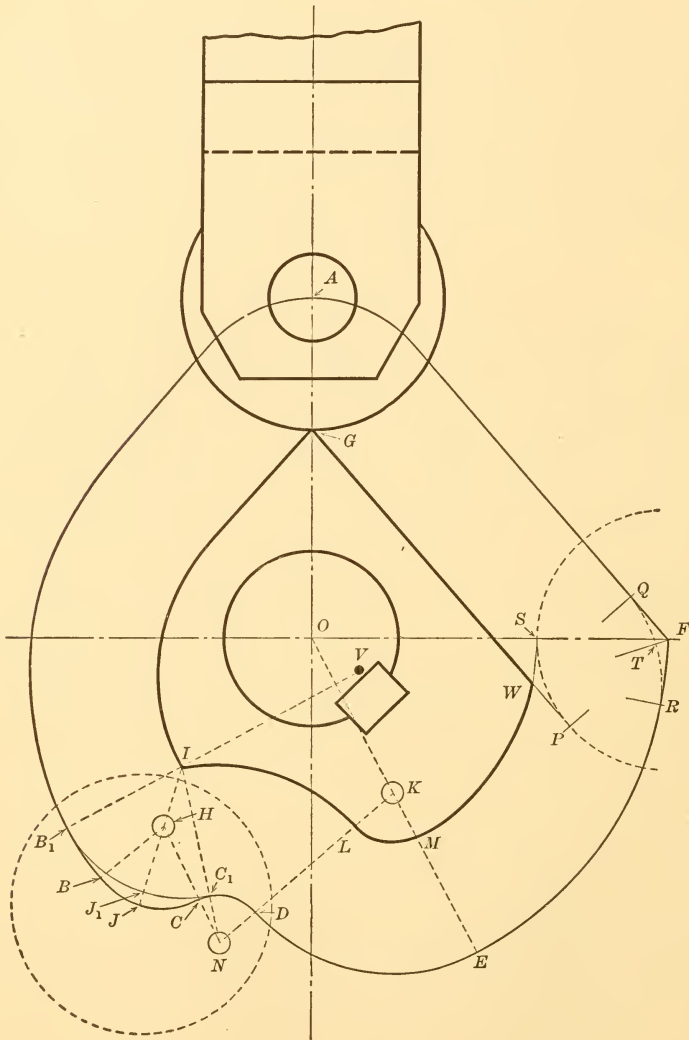

FIG. 37.—LIMITING SIZE OF FOLLOWER ROLLER

GA is the radius of curvature at A and AG is the radius of the roller. In this case both radii are equal and the working surface has a sharp edge at G .

58. CASE II. RADIUS OF ROLLER GREATER THAN RADIUS OF CURVATURE OF PITCH CAM. From B to C , Fig. 37, the radius of curvature of the pitch surface is HB , which is less than the roller radius. In this case the working surface will be undercut at I in generating the cam, and if the cam is built the center of the roller will mark the path $B_1J_1C_1$ instead of B_1JC_1 , and the follower will fail to move the desired distance by the amount JJ_1 .

59. SPECIAL APPLICATION OF CASE II. EFFECT OF AN ANGLE IN THE PITCH SURFACE OUTLINE. This is illustrated at RFQ in Fig. 37, and is a special application of Case II, in which the radius of curvature of the cam's pitch surface is reduced to zero. Undercutting is here illustrated by considering that a cutter, represented by the dash circular arc, is moving with its center on the pitch surface arc EF . It then cuts the working surface MS . As the center of the cutter is moved from F toward A , the part WS of the working surface which was previously formed is now cut away, leaving the sharp edge W on which the follower roller will turn when the cam is placed in operation. The center of the follower roller will then move in the path RTQ instead of RFQ , and the follower will fall short of the desired motion by the amount TF .

60. CASE III. RADIUS OF ROLLER LESS THAN RADIUS OF CURVATURE OF PITCH CAM. From D to E , Fig. 37, the radius of curvature of the pitch surface is KD , which is greater than the roller radius. In this case, which is the practical one, although close to the limit, a smooth curved working surface is provided for the roller from L to M .

61. RADIUS OF ROLLER NOT AFFECTED BY RADIUS OF CURVATURE ON NON-WORKING SIDE. From C_1 to D , Fig. 37, the radius of curvature of the pitch surface is less than the radius of the roller, but this short radius is not on the working side of the pitch surface, and therefore the roller will roll on the surface IL while its center travels on the pitch curve C_1D .

62. ROLLERS FOR POSITIVE-DRIVE CAMS. When the largest roller for a positive or double-acting cam is being determined the radius of curvature on both sides the pitch-surface curve must be considered and the smallest radius used. For example, in Fig. 37, if $AJET A$ were the pitch surface for a double-acting cam, NC would be the maximum roller radius, whereas HJ would be

the maximum radius if it were for an external single-acting cam.

63. RADIUS OF CURVATURE OF NON-CIRCULAR ARCS. In illustrating the above cases the pitch surface was assumed as being made up of straight lines and arcs of circles in order to show more effectively and more simply the limits of action in each instance. Where the pitch surface contains curves of constantly varying curvature, and they generally do in practice, the shortest radius of curvature of the pitch surface may be found with all necessary accuracy by trial with the compass, using finally that radius whose circular arc agrees for a small distance with the irregularly curved arc. For example, in Fig. 38, let $G H D J B$ be a portion of a pitch surface

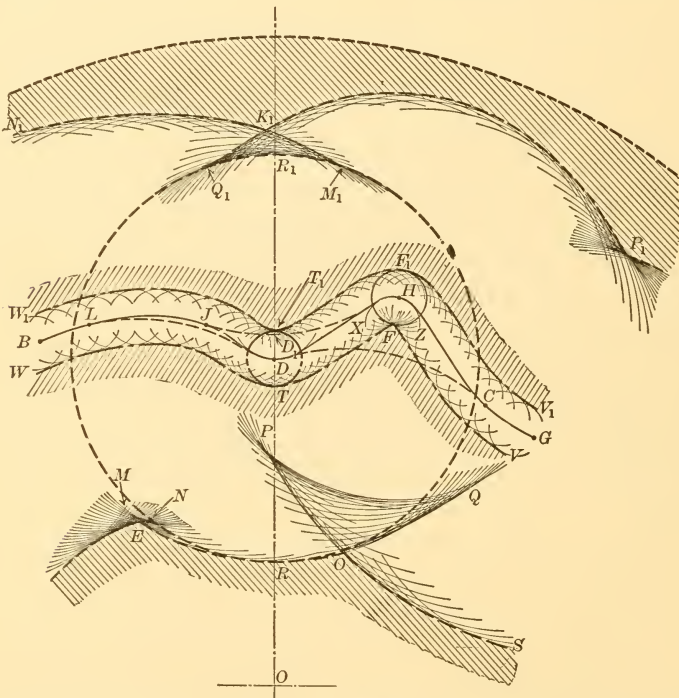

FIG. 38.—LIMITING SIZE OF FOLLOWER ROLLER WORKING ON NON-CIRCULAR CAM CURVES

made up of non-circular arcs. The shortest radius of curvature on both sides is found, by trial, to be $F H$. The center F is marked and the osculatory arc $X H Z$ drawn in. Then $H F$ is the largest possible radius of roller for a double-acting cam, and with this roller the working surfaces will be $V F T W$ and $V_1 F_1 T_1 W_1$.

If a larger roller is used, with a radius DR , for example, the working surfaces of the groove will be SOE and $P_1K_1N_1$, and the new pitch surface, after cutting the cam, will be $GCDLB$, if the roller is kept always in contact with the inner surface of the groove. If it is kept always in contact with the outer surface of the groove, the original pitch surface will be changed to $GCHD_1JB$. In either case the original desired follower motion is not obtained if the roller is too large, and if a positive-drive cam is run with the larger roller the follower's motion will be indeterminate, the center of the roller having any possible position between CDL and $CHJL$.

64. PROBLEM 5. DOUBLE-STEP RADIAL CAM. Required a double-step radial cam in which the center of the follower roller moves in a radial line. The maximum pressure angle to be 30° , and the follower to move:

- (a) Up 4 units in $\frac{1}{8}$ revolution on the crank curve.
- (b) At rest for $\frac{1}{4}$ revolution.
- (c) Up 4 units in $\frac{1}{8}$ revolution on the parabola curve.
- (d) Down 2 units in $\frac{1}{8}$ revolution on the elliptical curve.
- (e) At rest for $\frac{1}{8}$ revolution.
- (f) Down 6 units in $\frac{1}{4}$ revolution on the parabola curve.

65. In Problem 3 there are only two motion assignments, (a) and (b), in the data, and they were the same except for direction. Consequently only one computation was necessary. When two or more dissimilar assignments are made in the data, as in the present problem, it is advisable to make a computation for the length of the chart diagram for each motion specification, as follows:

- (a) $4 \times 2.72 \times 8 = 87.04$, which is the length of chart and of the pitch circle circumference = 13.86 pitch circle radius.
- (c) $4 \times 3.46 \times 8 = 110.72$, which is the length of chart and pitch circle circumference = 17.62 pitch circle radius.
- (d) $2 \times 3.95 \times 8 = 63.20$, which is the length of chart and pitch circle circumference = 10.06 pitch circle radius.
- (f) $6 \times 3.46 \times 4 = 83.04$, which is the length of chart and pitch circle circumference = 13.22 pitch circle radius.

Inasmuch as there is a different length of chart and a different pitch line for each item in the data one can not tell which pitch line to take without some preliminary computation. For this purpose

a chart diagram is well adapted, as follows: Construct a rectangle, Fig. 39, with a height $A T$ equal to the total motion of the follower in one direction, 8 units in this case. Make the length $A A'$ of rectangle any convenient value entirely independent of any of the values computed above and label this according to the longest chart length as computed above. Lay off straight lines to represent the component parts of the base curve as assigned in the data and label them as shown at $A C, C B, B H$, etc. Draw the several pitch lines as at $F D, J I$, etc.

66. For general procedure, consider the pitch line which passes through the point calling for the longest chart length. This will be the pitch line $J I$ passing through G , Fig. 39, which calls for a chart length of 110.72 and a pitch radius of 17.62. If G is to be at

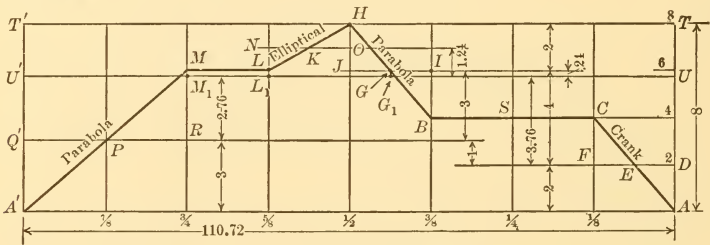

FIG. 39.—PROBLEM 5, CAM CHART DIAGRAM FOR DOUBLE-STEP CAM

a radius of 17.62 in the cam, E will be at a radius of $17.62 - 4 = 13.62$. But from computation (a) it is seen that E must be at a radius of 13.86. Therefore, if the radius of cam pitch circle is retained at 17.62, the trial pitch line, $J I$, on the chart diagram will have to be lowered, $13.86 - 13.62 = .24$, giving the new pitch line $U U'$. If the line $U U'$ now becomes the pitch circle the point E will be at $17.62 - 3.76 = 13.86$, just as called for in computation (a), and the pressure angle will be 30° at the point E on the cam.

The other critical points at P and K must also be tested with respect to the proposed pitch line, $U U'$. With this pitch line the point P will be 2.76 inside of the pitch circle, or at a radius of $17.62 - 2.76 = 14.86$. This is safe, as the computed radius for P was only 13.22 according to item (f). The point K is also safe, for it will be at a radius of $17.62 + 1.24 = 18.86$, whereas a radius of only 10.06 is required.

67. The cam may now be drawn by constructing the true cam chart as in Fig. 40, which is lettered the same as Fig. 39, and plotting the cam from it as in Fig. 41. The pitch line $U U'$ of Fig. 40 be-

(c) At rest for 45° .

(d) In 3 units in 120° on the crank curve.

70. PROBLEM 6. CAM WITH OFFSET ROLLER FOLLOWER. Required a single-step radial periphery cam in which the center of the follower roller moves forth and back in a straight line which does not pass through the center of rotation of the cam. The maximum pressure angle when the follower is at the bottom of its stroke is to be 30° , and the follower is to move:

(a) Up 3 units in 90° on the parabola curve.

(b) Down 3 " " 90° " " " "

(c) At rest for 180° .

71. Problems of this nature are totally different, both in pressure-angle action and in methods of construction, from the preceding ones. As may be noted in the data, it is required that the pressure angle, *when the follower is at rest at the bottom of its stroke*, shall be 30° . It will appear presently that the pressure angle, when the follower is in motion, may be zero or even negative on one of the strokes in this form of cam. It will also be shown that the maximum pressure angle during the follower motion cannot be assigned in advance and obtained in any practical manner. From the above it follows that the offset radial cam has a peculiar advantage in keeping considerable side pressure off the follower guides during the time that the follower is moving in one direction, although at the bottom of the stroke the pressure angle may have any desired value, and during the period of motion in the opposite direction the pressure angle will reach a maximum value much larger than the assigned angle at the bottom of the stroke.

72. The method of construction for the offset roller cam is illustrated in Fig. 43. The diameter of the pitch circle, $UF'ST$, is com-

puted as before by the formula, $d = 114.6 \frac{hf}{b}$, and found to be 13.22

units. An angle equal to the assigned pressure angle is then laid off at UOU' , UO being parallel to the direction of motion of the follower. Draw a line, DW , parallel to UO and so located that it has an intercept DA between the pitch circle and the inclined line equal to one-half the travel of the follower. This may be done by trial, or graphically, as shown by the dotted-line construction which is drawn at $Y'XA'$ instead of at Y to avoid complication of construction lines. The angle UOY' equals the angle UOY . $Y'X$, parallel to UO , is drawn equal to one-half the stroke. An arc XA' ,

parallel to the arc $Y' U$, is drawn through X by using $U O$ as a radius and Z as a center, where $O Z$ equals $Y' X$. A circular arc through A' with O as a center will intersect $O U'$ in the desired point A . The point A will then be the lowest point of the stroke, D will be the center of the stroke, and $W O$ the radius of the construction circle.

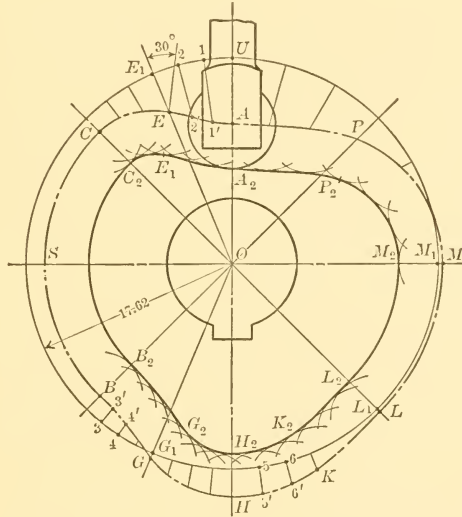

FIG. 41.—PROBLEM 5, DOUBLE-STEP CAM CONSTRUCTED FROM CAM CHART

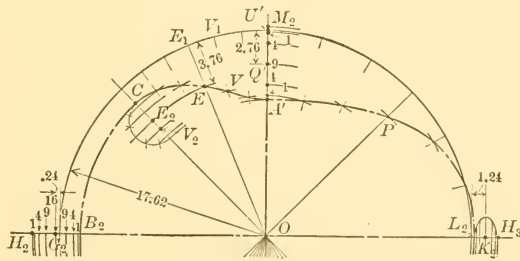

FIG. 42.—PROBLEM 5, DOUBLE-STEP CAM CONSTRUCTED WITHOUT USE OF CAM CHART

The distance $A V$ is equal to the assigned 3 units of motion, and the divisions 1, 4, 9 . . . are made according to the requirements of the parabola curve. The assigned 90° is laid off on the construction circle at $W F$ and divided into a number of equal arcs at $H, I, J . . .$ corresponding to the number of divisions at $A V$, eight being used in the present example. Tangents to the construction circle,

such as $H H_1, I I_1, J J_1 \dots$ are then drawn at $H, I, J \dots$ and the distances $W1, W4, W9 \dots$ laid off on these tangents, thus giving the points $H_1, I_1, J_1 \dots$ on the pitch surface of the cam. Or these latter points may be obtained by swinging arcs through $1, 4, 9 \dots$ about O as a center, until they meet the respective tangents at $H_1, I_1, J_1 \dots$.

73. An examination of the pressure angles for a cam with an offset follower shows that during the up stroke the pressure angles are very small, being, in fact, negative from J_1 to K_1 , Fig. 43, and, when measured, the average pressure angle for the working or up stroke is between 6 and 7 degrees in this problem; although on the down or return stroke it reaches an average of between 37° and 38° and a maximum of 46° near Q' . In this class of problem the computation for diameter of pitch circle serves merely as a guide in determining a size that will give a small cam and a small average pressure angle on the working stroke. If the diameter of the pitch circle is arbitrarily taken either larger or smaller than the value, as above computed, or if other base curves are used, the negative pressure angles at J_1, E_1 , and K_1 may disappear entirely; which would be an advantage where it is desired to have pressure on the follower guides on one side only.

74. It has doubtless been observed that there is a decided lack of symmetry in this form of cam, even though the data are similar for both strokes of the follower. This is illustrated in Fig. 43, where the portion AC of the pitch surface for the outstroke is quite different from the portion CM . It is also characteristic of this form of cam that the pitch and working curves each embrace either a smaller or a larger angle than the assigned angle for a given stroke of the follower, as shown by the angle AOC being less, and the angle COM being greater, than the assigned 90° . This, of course, is due to the fact that when C has traveled 90° to V the line OC will have passed the original zero line OA of the pitch curve and will be in the position OV . Therefore, the cam angle for one stroke of the follower will be less than the assigned angle by the amount of the angle included by VOA ; for the other stroke it will be greater than the assigned angle by the same amount.

75. EXERCISE PROBLEM 6a. Required a single-step radial periphery cam in which the center of the follower roller moves forth and back in a straight line which does not pass through the center of rotation of the cam. The maximum pressure angle when the follower is at the bottom of its stroke is to be 30° , and the follower is to move:

- (a) Out 6 units in 135° on the crank curve.
 (b) In 6 " " 135° " " " "
 (c) Rest for 90° .

In this problem, only the initial pressure angle at the bottom of the stroke need be shown; the pressure angles at other positions, such as are shown in Fig. 43 at H_1, I_1 , may be omitted.

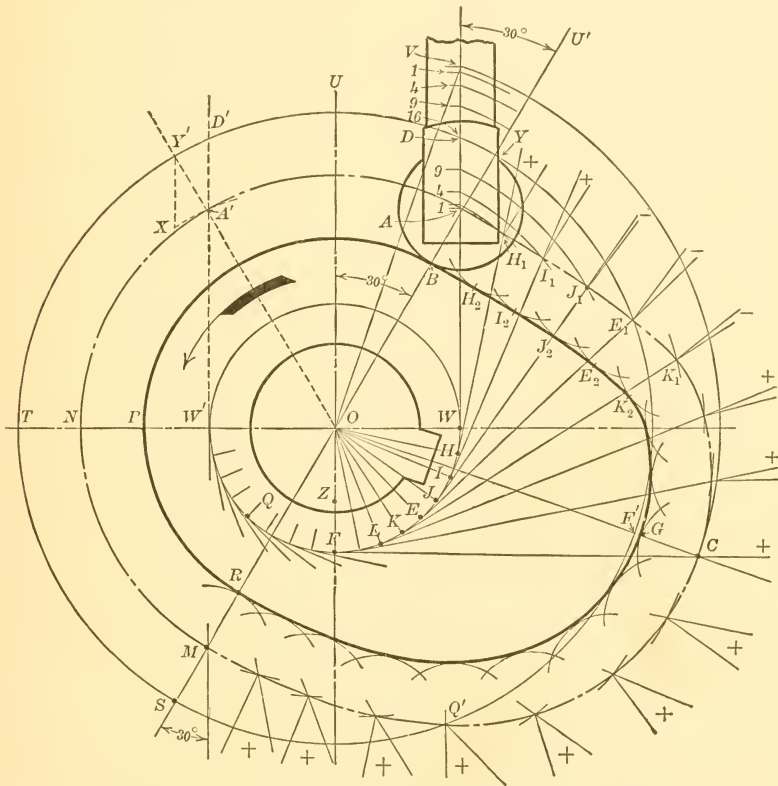

FIG. 43.—PROBLEM 6, CAM WITH OFFSET ROLLER FOLLOWER

76. PROBLEM 7. CAM WITH FLAT SURFACE FOLLOWER,—MUSHROOM CAM. Required a radial periphery cam to operate an offset follower which has a flat surface instead of a roller. The follower to move:

- (a) Up 3 units in 90° on the parabola base.
 (b) Down 3 " " 90° " " " "
 (c) At rest for 180° .

77. This type of cam is known also as the mushroom cam. Flat

surface followers may be offset as shown in the side and top views in Fig. 44, where the center line $N'' Y''$ of the follower spindle is set the distance $P'' O''$ in front of the center of the cam plate. In this case there will be a part sliding and part rolling of the cam on the follower and the follower will turn about its own axis, $N'' Y''$, as it

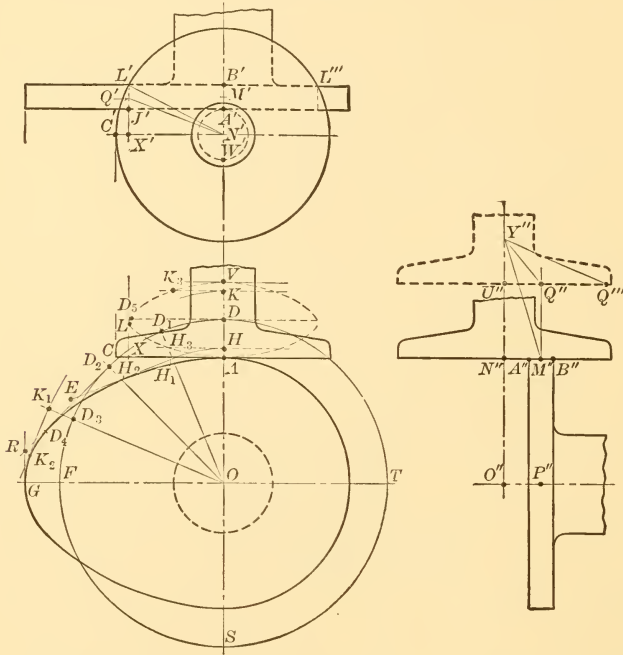

FIG. 44.—PROBLEM 7, CAM WITH FLAT SURFACE FOLLOWER—MUSHROOM CAM

is being raised and lowered. When the follower is not offset, *i.e.*, when the center line $O'' N''$ is placed in line with $M'' P''$, the action will be all sliding and there will be no turning of the follower spindle on its axis. In this case there will be localized wear on the follower, while in the former case the wear will be more widely distributed over the follower surface. In both cases the construction is the same and is explained in the following paragraph.

78. In cam followers having flat surfaces perpendicular to the line of action, the line of pressure is $M'' Q''$ and is parallel to the line of action of the follower, instead of being inclined to it as in the case of cams having roller followers. Because of this characteristic action the ordinary pressure-angle factors do not apply in

cams of this class in computing or obtaining the diameter of the pitch circle $DFST$, and this circle may be assumed. In some cases a fair guide for the size of this circle may be obtained by using

the regular formula, $d = 114.6 \frac{hf}{b}$, for diameter of pitch circle, as-

suming the 30° pressure angle factor. Solving, r is found to equal 6.61, and is laid off at OD . The assigned three units of motion are then laid off, one-half on each side of D , as at A and V . The assigned 90° are next laid off at AOF and divided into the desired number of construction parts, four being used in this case, as at OD_1, OD_2, \dots . The distance AV is also divided into four parts, AH and VK being each equal to 1 unit and HD and KD equal to 3 units. Only four divisions are taken in this case to avoid confusion of lines in the illustration, but in student problems 6 or 8 points should be taken, and in practical work 12 to 24 divisions should be used. The first division point, H , is now revolved to meet the first radial division line OD_1 , thus giving the point H_1 , where a line H_1E is drawn perpendicular to H_1O . This line H_1E represents the bottom of the follower disk AC with reference to the cam when the cam has turned through the angle AOH_1 . The points D_2 and K_1 are obtained in the same manner as was H_1 and corresponding perpendiculars are drawn, as at D_2D_4 and K_1K_2 . As smooth a curve as possible is now drawn tangent to these perpendiculars and the points of tangency marked as at H_2, D_4 , and K_2 . This smooth curve, AG , is the working surface of the cam.

79. The size of the follower must also be determined. The most satisfactory way of doing this is to find, first, the locus, or path, of the line of contact between the periphery of the cam and the follower disk. This is obtained by considering that when H_1 is at H , the point of tangency H_2 is at H_3 , the length HH_3 being equal to H_1H_2 . Likewise, when D_2 is at D , D_4 is at D_5 , and the same for the other points of tangency. The dash line curve through the points $AH_3D_5K_3 \dots$ is the locus of contact between the cam and the follower. The point L is the extreme point of this curve and if the follower were not offset, the length of an ordinary toe or flat extension of the follower would have to be at least equal to $N'X'$. If the follower is offset, say by the amount $N'M'$ ($= N''M''$), the radius of the disk will have to be at least equal to $N'L'$, and the extreme line of contact will be $L'J'$. The other extreme line of contact will be a similar line through L''' , and the area of the flat disk which will

be subject to wear will be the annular surface between the periphery and the dashline circle whose radius is $N' A'$. As to the wear on the cam itself, there would be pure sliding of the curved surface $A G$ on the flat surface $A X$ if the follower were not offset. With an offset follower there is an effective turning radius equal to the offset

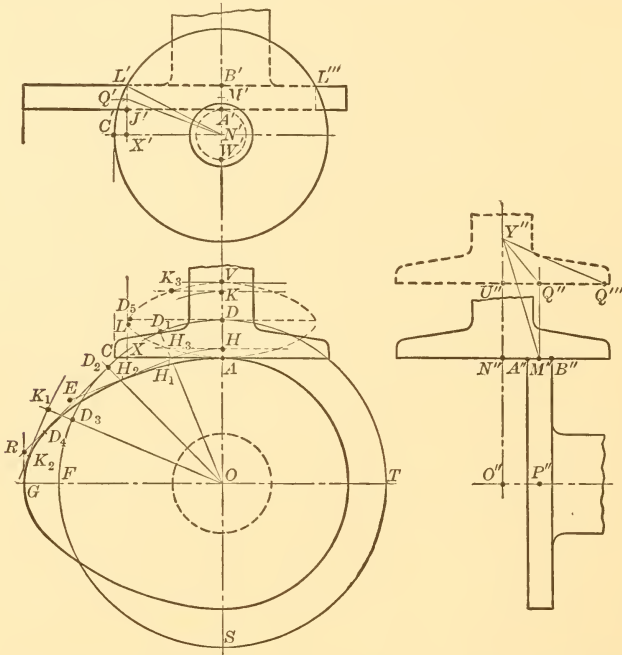

FIG. 44.—(Duplicate). PROBLEM 7, CAM WITH FLAT SURFACE FOLLOWER—MUSHROOM CAM

$N' M'$ tending to rotate the follower about its axis $N'' Y''$, and this changes the action of the cam on the follower entirely by causing part rolling and part sliding.

80. The pressure angle in this form of cam must be considered differently from cams which operate against rollers. In roller follower cams it is the angle between the normal to the cam surface and the line of action of the follower that determines the side pressure on the bearings, whereas in flat surface followers it is the distance that the line of contact is away from the line of action that determines it. This distance varies constantly, and in the illustration in Fig. 44 the limits of variation are $M' N'$ and $Q' N'$. These are, in reality, lever arms on which the pressure acts to produce a turning moment

which must be resisted by the follower guides. Since there can be no pure rolling action between the cam and follower in constructions of this type, there is nothing to be gained in this particular by a large offset. On the contrary, there is much to be lost, due to the large turning moment on the follower rod. A fair guide as to the offset would be to keep the angle formed by the center line $Y'' O''$ of the follower motion and the line $Y'' M''$ or $Y'' Q''$ joining the center of the bearing with the midpoint of the line of contact, to within, say, 30° , or any other maximum value that circumstance might warrant. The angle here defined might be termed the pressure angle in this type of cam. The minimum pressure angle, $N'' Y'' M''$, is seen in its true size, while the maximum pressure angle as projected at $U'' Y'' Q''$ must be revolved about $U'' Y''$ as an axis until $U'' Q''$ equals $N' Q'$, when it will appear in its true size as at $U'' Y'' Q'''$.

81. LIMITED USE OF CAMS WITH FLAT SURFACE FOLLOWERS. Cams with followers of this type are not well adapted, in general, for cases in which the follower must have specified velocities during its stroke. If the follower is required only to move from one end of its stroke to the other in a given period of time, independently of all intermediate velocities, this form of construction may be readily applied. The principal difficulties to be met in the building of these cams, when the intermediate velocities are specified, are, first, the large time angles necessary for a desired follower motion, or, second, a comparatively large cam. The cause of these difficulties may be pointed out in Fig. 44, where it may be seen that the construction point, K_1 , might have been so much further out radially that the perpendicular line, $K_1 K_2$, would have passed to the left of R and it would have been impossible to draw the smooth cam curve AG tangent successively to *all* the perpendiculars. The limiting practical case appears when any three successive construction lines meet in a point, in which event the cam will have a sharp edge and be subject to excessive wear at that point. This subject is further considered in paragraph 106.

82. If one is not limited in the time, or angle, in which the follower must do its work; or, if not limited in the size of the cam, this form of construction may be used for any set of velocity values so long as they produce a working surface which always curves outward or which has an edge which points outward.

83. EXERCISE PROBLEM 7a. Required a radial periphery cam to operate an offset follower which has a flat surface perpen-

dicular to the line of motion instead of a roller, the follower to move:

- (a) Up 3 units in 90° on the crank curve.
- (b) Down 3 " " 90° " " " "
- (c) Rest for 180° .

Take cam disk to be one unit thick and the follower offset equal to two units measured from center of cam disk. Find and mark the locus of contact, also the size of the follower disk and the area of follower surface subject to wear.

84. CAMS FOR SWINGING FOLLOWER ARMS. In the previous problems the motion of the center of the follower roller has been in a straight line. When the center of the roller moves in a curve a different method of construction is used to advantage. Cams with swinging followers are illustrated in Figs. 45 and 46, the arc of swing AV of the follower having its extremities on a radial line in the former illustration; and on an arc which, continued, passes through the center of the cam in the latter illustration. These two forms of construction, although apparently differing in only a slight detail, give quite different results and each has its own particular field of usefulness. A comparison of the results will be given in paragraph 95 after a problem in each case has been worked out.

85. PROBLEM 8. CAM WITH SWINGING FOLLOWER ARM, ROLLER CONTACT—EXTREMITIES OF SWINGING ARC ON RADIAL LINE. Required a radial periphery cam to operate a roller follower where the follower arm swings about a pivot and where the two extreme positions of the center of the roller lie on a radial line. The chord of the swinging arc of the roller center is to be 4 units and the length of the follower arm 8 units. The follower arm to swing:

- (a) Out full distance in 90° on parabola curve.
- (b) In " " " 90° " crank "
- (c) And to remain at rest for 180° .

86. A different method of construction from any thus far employed is used in problems of this kind because it gives the simplest and most accurate layout for the pitch surface. Briefly, the method to be used consists in revolving the follower through the 360° around the cam while the cam remains stationary, and drawing the follower in a number of its phases while on the way around. One of the phases is represented in full by the dash lines $C_{10} Y_2 Y_3$ in Fig. 45.

87. The angle which causes pressure against the follower bearings is also different in this form of cam from any of the others. An inspection of Fig. 45 will show that, in general, the normal line of

pressure, AV at A , between the cam surface and the roller is not at right angles to the position of the follower arm, and, therefore, that the resultant total pressure has a component along the arm, tending to place it in compression and throwing a corresponding pressure on the follower bearing at C . The pressure angle at A is shown by $-a$, the minus sign indicating compression in the swinging arm. When K_1 is at K the pressure angle will be $+c$, the plus sign indicating tension in the follower arm. A disadvantage of the sign changing from $+$ to $-$, etc., is that as soon as the bearings wear there will be noise at that point.

88. The detail for the construction of problem 8 is taken up by computing the diameter of the pitch circle first, as in previous problems. This computation, however, serves only as a guide, for the assigned pressure angle will be both increased and decreased by amounts depending on the radius of the follower arm and the characteristics of the base curve which is used. For computing the pitch circle then, an assigned pressure angle factor for 30° will be assumed in the expectation that the final maximum angle will not

exceed 40° . From formula 1, paragraph 29, $d = 114.6 \frac{4 \times 3.46}{90}$

$= 17.62$ for the parabola curve; and $d = 114.6 \frac{4 \times 2.72}{90} = 13.86$

for the crank curve assignment. The radius of the pitch circle is thus found to be 8.81 units.

89. Having determined the radius OD , Fig. 45, for the pitch circle, the given chord of 4 units is laid off with equal parts on each side of D , thus locating the ends of the swinging arc AV on the radial line OD as required. With A and V as centers and a radius of 8 units for the length of the follower arm, strike arcs which will intersect at C and give the fixed center for the follower arm. The arc AV , showing the path of the center of the follower roller is now drawn.

90. Points on the pitch surface AV_1A_2F are found, in brief, by revolving the arm CA around O , swinging it a proper amount on its center C as it revolves. In detail this is accomplished by laying off the arc CC_6 equal to 90° , and dividing it into a number of equal parts, say six. Divide the arc AJ into three unequal parts, as at H and I , for the parabola curve. Lay off the points L and K in the same way. Then with CA as a radius and with $C_1, C_2 \dots$ as centers draw the arcs passing through $H_1, I_1 \dots$. Again, with

O as a center, swing arcs through $H, I \dots$ until they meet the arcs already constructed. The intersections of these arcs, as at $H_1, I_1, J_1 \dots$ will be the points on the desired pitch surface AV_1 . The determination of the pitch surface for the crank curve is found by laying off the second 90° assignment from C_6 to C_{12} and dividing it into six parts. The arc $A_1 V_1$ is divided by projecting the points $UW \dots$ of the crank circle to the points $U_1 W_1$ on the arc. The constructions for the points $U_2, W_2 \dots$ are the same as for the previous part of the pitch surface, as described above.

91. EXERCISE PROBLEM 8a. Required a radial periphery cam to operate a roller follower where the follower arm swings about a pivot and the two extremities of the swinging arc lie on a radial line. The 30° pressure angle factor to be used in computing the pitch circle radius. The chord of the swinging arc to be 3 units, the arm 9 units long, and to:

- (a) Swing out in $\frac{1}{3}$ revolution on the crank curve base.
- (b) Remain at rest for $\frac{1}{3}$ revolution.
- (c) Swing in in $\frac{1}{3}$ revolution on the parabola base.

92. PROBLEM 9. CAM WITH SWINGING FOLLOWER ARM, ROLLER CONTACT—SWINGING ARC, CONTINUED, PASSES THROUGH CENTER OF CAM. Required a radial periphery cam to operate a roller follower where the follower arm swings about a pivot, and where the center of the follower roller moves on an arc which, continued, passes through the center of the cam. The chord of the swinging arc of the roller center is 4 units and the length of the follower arm 10 units. The follower arm to swing:

- (a) Out full distance in 90° on parabola curve.
- (b) In " " " 90° " crank "
- (c) To remain at rest for 180° .

93. The procedure for this problem is the same as for Problem 8 in all respects except the layout of the arc of swing for the center of the follower roller. The pitch circle is drawn with radius OJ , Fig. 46.

With the center of the cam O and the pitch point J as centers draw arcs which intersect at C , the radius being equal to the length of the follower arm. Lay off JA and JV equal to each other and so that a chord drawn from A to V equals the four units assigned. A bent rocker, ACE , is introduced in Fig. 46 simply to change the direction of motion.

94. EXERCISE PROBLEM 9a. Required a radial periphery cam to operate a roller follower where the follower arm swings about a pivot,

and where the center of the follower roller moves on an arc which, continued, passes through the center of rotation of the cam. Take the length of follower arm as 12 units and its angle of swing 30° . Required that the follower arm:

- Swing out full distance in $\frac{3}{8}$ revolution, on crank curve.
- Remain at rest $\frac{1}{4}$ revolution.
- Swing in full distance in $\frac{3}{8}$ revolution, on crank base.

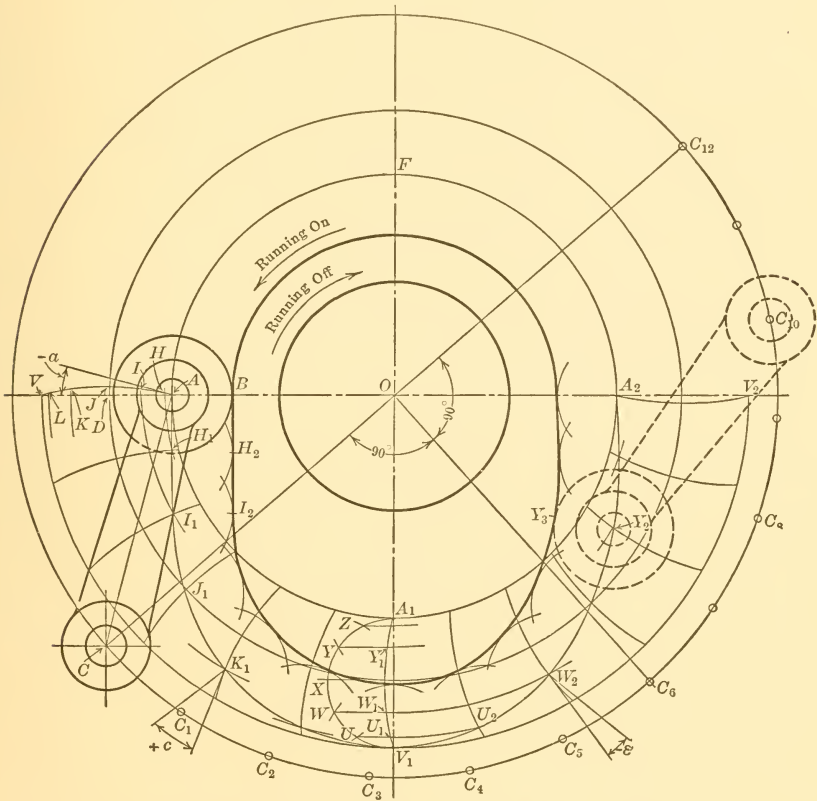

FIG. 45.—PROBLEM 8, CAM WITH SWINGING FOLLOWER ARM, ROLLER CONTACT—EXTREMITIES OF SWINGING ARC ON RADIAL LINE

95. EFFECT OF LOCATION OF SWINGING FOLLOWER ARM RELATIVELY TO THE CAM. When the swinging follower arm is mounted so that the extremities of the arc of travel of roller center are on a radial line, as in Problem 8, the pressure angles on the out and in strokes will be approximately the same. When the follower roller center

Cams operate smoother when "running off" than when "running on." A cam is said to be "running off" when the point of contact on the working surface of the cam is moving away from the fixed center of the swinging follower arm. A cam of the type illustrated in Problem 8 will have an axis of symmetry where the same data are assigned for the out and in stroke, whereas the cam illustrated in Problem 9 will be quite unsymmetrical for same data.

96. POSITIVE-DRIVE FACE CAMS. The pitch surfaces for face cams are laid out in exactly the same manner as pitch surfaces for radial periphery cams. The only additional feature is that a working surface is drawn to touch each side of the roller.

97. PROBLEM 10. FACE CAM WITH SWINGING FOLLOWER. Construct a face cam for a swinging follower arm, roller contact. Arm to be 12 units long and to swing through 30° . Required that the arm shall:

(a) Swing full out on the combination curve while the cam makes $\frac{5}{8}$ revolution.

(b) Swing full in on the combination curve while the cam makes $\frac{3}{8}$ revolution.

98. In order to compute the radius of the pitch circle it is necessary to find the travel, or the approximate travel, of the center of the follower roller. This is graphically done by making a separate sketch, as in Fig. 47, drawing the angle XYZ equal to 30° , drawing the arc ZX with a radius of 12 units, and measuring the chord ZX , which is found to be 6.2 units. Or, this value may be found trigonometrically, without any drawing, by taking $12 \times 2 \sin 15^\circ = 6.2$. The radius of the pitch circle will then be:

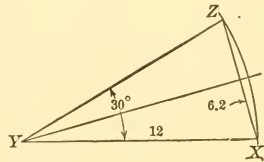

FIG. 47.—TO FIND CHORD MEASURE OF TRAVEL OF POINT ON SWINGING ARM

$$6.2 \times 2.27 \times \frac{8}{3} \times \frac{1}{3.14} \times \frac{1}{2} = 6.0 \text{ units.}$$

99. To construct the cam, the value just found is laid off at OJ , Fig. 48, and the pitch circle drawn. With the combination curve a cam chart, a partial one at least, must be drawn. To do this with least effort, select any point J' in line with the pitch point J and draw the line $J'V'$ at the given pressure angle, 30° in this case, until it is 6.2 units long. With V' as a center, draw arc $J'A'$ and also draw a tangent to it at J' and produce it to S' where $R'S'$ equals

100. EXERCISE PROBLEM 10a. Required a face cam for a swinging follower arm, roller contact. Arm to be 10 units long. Center of roller to swing through an arc whose chord is 4 units, and this arc, when continued, to pass through center of cam. The arm to:

(a) Swing to the right on combination curve while cam turns 180° .

(b) Swing to the left on combination curve while cam turns 180° .

101. PROBLEM 11. CAM WITH SWINGING FOLLOWER ARM, SLIDING SURFACE CONTACT. Required a radial periphery cam to operate a swinging arm having a construction radius of 9 units. Sliding surface contact between cam and follower. The arm to:

(a) Swing up 4 units on the crank curve base while the cam turns 120° .

(b) Swing down 4 units on the crank curve base while the cam turns 120° .

(c) Remain at rest for 120° .

102. This type of cam and follower is illustrated in Fig. 49. The line of pressure between cam and follower is always normal to the follower surface and consequently there is no component of pressure in the bearing at C due to pressure angle. This cam is, therefore, independent of a pitch circle based on pressure angle, and the pitch circle may be taken any size. Where one has no special guide in assuming a starting size for the cam, the usual computation for pitch circle for a 30° pressure angle may give good average results. According to this, the pitch radius OD will be,

$$4 \times 2.72 \times 3 \times \frac{1}{3.14} \times \frac{1}{2} = 5.2 \text{ units}$$

AV equals 4 units and AC equals 9 units. The point A is taken, for construction purposes, as a point on the follower arm where the angular velocity of the arm is measured. It will be at the points $H, I, J \dots$ on the arc AV at the end of equal succeeding intervals of time.

103. The method of constructing the cam in this problem is identical with the method used in Problem 8 in so far as the follower arm is swung around the cam, and its position with respect to the cam center at equal time intervals is drawn. The departure from the method of Problem 8 consists in drawing the cam outline as an envelope to these follower-arm positions. For example, in Fig. 49, at the end of the third time interval the pivot C has been revolved to C_3 and the point A of the follower arm has moved out

dash closed curve through M_1 and N_1 . By drawing arcs tangent at the extremities of this dash curve, using C as a center in both cases, the points F and G on the follower surface are obtained and the distance FG will be the part of the follower exposed to wear from the rubbing of the cam. This part of the follower arm may be designed with a shoe, as indicated, which may be replaced when worn.

105. It should be specially noted that the shortest radius of the cam is not OA , but OB . The point B is found by drawing a perpendicular to CG through O .

The very decided lack of symmetry should also be noted, the curve BL being used to lift the arm, and the curve LE to lower the arm, the swinging velocities of the arm being the same in both directions.

106. DATA LIMITED FOR FOLLOWERS WITH SLIDING SURFACE CONTACT. The data for this type of cam construction are extremely limited when the swinging velocity of the arm is assigned. The limitations are that the working surface of the cam must be drawn *tangent to every construction line in succession*, and that it must be convex externally at all points. In most arbitrary assignments of data the construction line through C_9 , for example, would intersect the line through C_7 before it cut the line through C_8 . In this case it would be impossible to draw a smooth working curve tangent, *successively*, to the lines through C_7 , C_8 , and C_9 . This is illustrated more clearly in Fig. 51 and will be more evident after the limiting case is described.

The limiting case for flat surface followers with sliding contact occurs where three or more of the construction lines meet in a point, as at N in Fig. 50. In this case the working surface of the cam

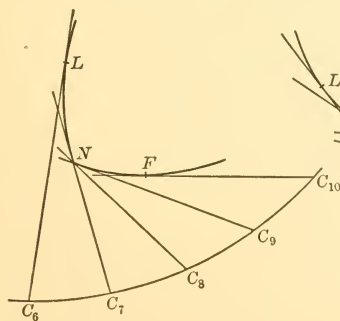

FIG. 50.—LIMITING CASE FOR STRAIGHT EDGE FOLLOWER WITH SLIDING CONTACT

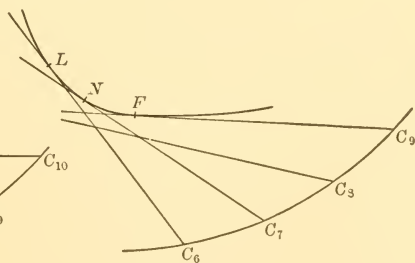

FIG. 51.—IMPOSSIBLE CASE FOR STRAIGHT EDGE FOLLOWER WITH SLIDING CONTACT

would have a sharp edge. In this type of cam it is necessary to use more construction lines than in other types, because it is possible to have the construction lines so far apart that such a case as is shown in Fig. 51 might not evidence itself at all. For example, if the distance $C_9 C_7$ were the unit space for construction lines, instead of $C_9 C_8$, the smooth convex curve FNL could be drawn tangent to lines through $C_9, C_7 \dots$ without the error showing itself.

107. If it is required of this cam only that it shall swing a follower arm through a given angle in a given time, without regard to the

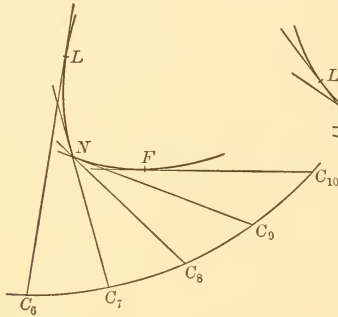

FIG. 50.—(Duplicate.) LIMITING CASE FOR STRAIGHT EDGE FOLLOWER WITH SLIDING CONTACT

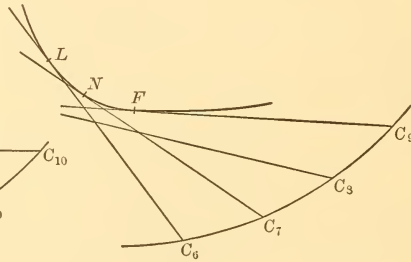

FIG. 51.—(Duplicate.) IMPOSSIBLE CASE FOR STRAIGHT EDGE FOLLOWER WITH SLIDING CONTACT

intermediate velocities of the arm, it may be as widely used as any other type of cam. In this case only the innermost and outermost positions of the arm would be drawn, as at $CA, C_6 V_1$, and $C_{12} E$, Fig. 49, and a smooth convex curve drawn tangent to these lines. Such construction, however, might give an irregular or jerky motion to the follower. Whether it did or not could be readily determined by laying off a number of equal divisions, as at $C_1, C_2 \dots C_{12}$; drawing lines, such as $C_3 J_1$, tangent to the assumed smooth convex working surface; and revolving $C_3 J_1$ back to CJ . After doing this with other construction lines a series of points, such as $H, I, J \dots$ would be determined and the spaces between them would represent the distances traveled by A on the follower arm during successive equal intervals of time.

108. EXERCISE PROBLEM 11a. Required a radial periphery cam for a swinging follower arm, sliding surface contact. Arm to be 10 units long to the point which is used to measure the angular velocity, and this point to move through an arc which is measured by a chord of 4 units. The arm is to:

(a) Swing full out with uniform acceleration and retardation while the cam turns $\frac{3}{8}$ revolution.

(b) Swing in with the same angular motion in $\frac{3}{8}$ revolution.

(c) Remain stationary for $\frac{1}{4}$ revolution of the cam.

109. TOE AND WIPER CAMS. In this form of cam construction the cam or "wiper" OC , Fig. 52, oscillates or swings back and forth through an angle of 120° or less, instead of rotating continuously the full 360° as it does in all cams thus far considered. The follower or "toe" AW is usually a narrow flat strip resting on the curved periphery of the cam, and moving straight up and down. There is sliding action between the wiper and the toe.

110. PROBLEM 12. TOE AND WIPER CAM. Required a wiper cam to operate a flat toe follower which shall move:

(a) Up 4 units with uniform acceleration all the way while the cam turns counterclockwise 45° with uniform angular velocity.

(b) Down 4 units with uniform retardation all the way while the cam turns clockwise 45° with uniform angular velocity.

111. The detail of construction for this class of problem is identical with that described for the mushroom cam in Problem 7, it being observed that the two cams differ only in that the mushroom cam turns through the full 360° instead of 45° as in this problem, and the mushroom follower is circular instead of rectangular. Neither of these differences nor the offset of the mushroom follower affect the similarity of construction for the two types of cams. Therefore, only a brief review of the general method of construction for the present problem will be given here.

112. Inasmuch as the line of pressure between cam and follower is always parallel to the direction of motion of the follower in problems such as this, there is no pressure angle in the ordinary sense. If a computation for size of cam is made in the usual way, the radius of the pitch circle will figure to be unnecessarily large, due principally to the fact that only a 45° degree turn of the cam is allowed for the upward motion of the follower.

A radius OA , Fig. 52, which allows for radius of shaft, thickness of hub, etc., is assumed, and the follower motion of 4 units is laid off at AV . This distance is divided into four unequal parts at $H, I \dots$ which are to each other as 1, 3, 5, and 7, thus giving uniform acceleration all the way up. The angle AOB of the cam is laid off 45° and is divided into four equal time parts. The follower or toe surface AW is then moved up the distance AH and revolved through the angle AOI to the position $H_1 H_2$ which is marked. Simi-

larly $A W$ is next moved to $I I_3$ and revolved to $I_1 I_2$. The smoothest possible convex curve is then drawn to the lines $H_1 H_2, I_1 I_2 \dots$ and this curve becomes the working surface of the wiper.

The necessary working length for the wiper is found to be $A V_2$, and, adding a small arbitrary distance, $V_2 C$, the total length is taken

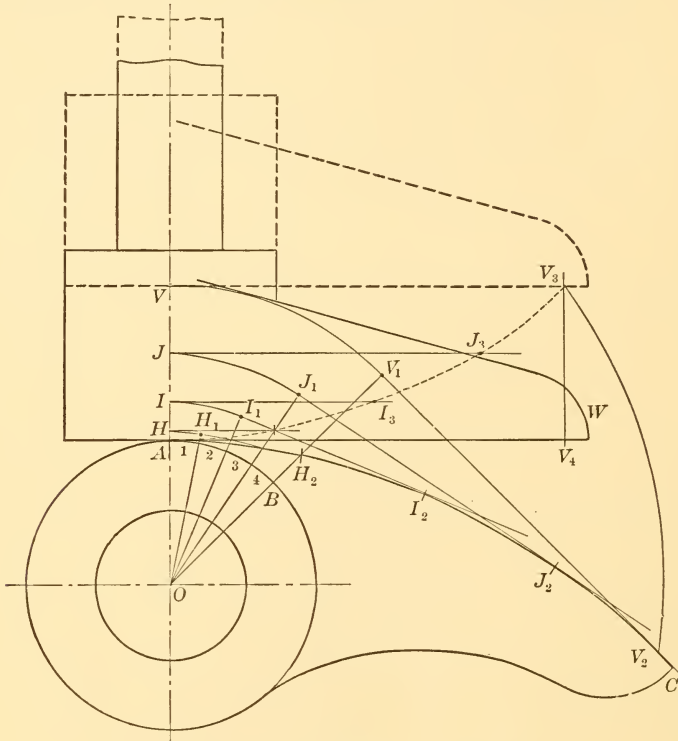

FIG. 52.—PROBLEM 12, TOE AND WIPER CAM

as $A C$. The total length of the toe $A W$ will be equal to $V_1 C$. The long dash lines in Fig. 52 indicate the highest position of the toe and wiper, and the short dash-line curve marks the locus of contact between the wiper and toe. This curve is obtained by making, for example, $J J_3$ equal to $J_1 J_2$.

113. MODIFICATIONS OF THE TOE AND WIPER CAM. The toe and wiper cam constructions are commonly used. In the present elementary problems the cam or wiper is assumed to oscillate with uniform angular velocity, whereas in practice it usually has a variable angular velocity due to the fact that it is operated through a rod which is connected at the driving end to a crank pin or eccentric

whose diameter of action corresponds to the swing of the wiper cam. The follower toe may be built with a curved instead of a straight line, by a slight modification in detail which consists in drawing the curved toe line in place of the straight lines, $H_1 H_2, I_1 I_2 \dots$ as shown in Fig. 52. These points, together with a consideration of the amount of slip between the surfaces in this type of cam and a discussion of the necessary modification to secure pure rolling in cams of this general appearance, are subjects for more advanced work than is covered by the present elementary problems.

114. EXERCISE PROBLEM 12a. Required a wiper cam to operate a flat toe follower which shall move:

(a) Up 3 units with uniform velocity while the cam turns 60° in a counterclockwise direction with uniform angular velocity.

(b) Down 3 units with uniform velocity while the cam turns 60° in a clockwise direction with uniform angular velocity.

115. YOKE CAMS. Yoke cams are simple radial periphery cams in which two points of the follower, instead of one, are in contact with the working surface. The contact points are usually diametrically opposite to each other. Roller contact is generally used and the centers of the rollers are a fixed distance apart. The yoke cam gives positive motion in both directions, and does not depend on a spring or on gravity to return the follower as do all other cams thus far considered, excepting the face cam.

116. PROBLEM 13. SINGLE-DISK YOKE CAM. Required a single radial cam to operate a yoke follower with a maximum pressure angle of 30° :

(a) Out 4 units in 45° turn of the cam, on crank curve.

(b) In 4 " " 90° " " " " " " " "

(c) Out 4 " " 45° " " " " " " " "

117. With a single radial cam for a yoke follower, data may be assigned only within the first 180° . The reason for this will appear presently.

Compute the radius of pitch circle as in ordinary radial cam problems. It is found to be 13.86 units and is laid off at OD , Fig. 53. The pitch surface, $AD_1V_1A_1V_2$, is found in the usual way. Then the diametral distance, AV_2 , will be the fixed distance between the centers of the rollers, and if this distance is laid off on diametral lines, as from $I_1, K_1 \dots$, the points $W, X \dots$ on the complementary pitch surface will be located. A size of roller AB is next assumed and the working surface BB_2 is constructed. The maximum radius of the working surface is finally located, as at OB_2 . A small amount

is added to this for clearance and the total laid off at OZ , thus giving the width of yoke necessary for an enclosed cam.

118. LIMITED APPLICATION OF SINGLE-DISK YOKE CAM. In yoke cams constructed from a single disk the data are limited in two ways:

First, data can be assigned for the first 180° only, because the pitch surface for the second 180° must be complementary to the pitch surface in the first 180° .

Secondly, the complementary pitch surface cannot approach any nearer to the center of rotation of the cam than does the pitch surface

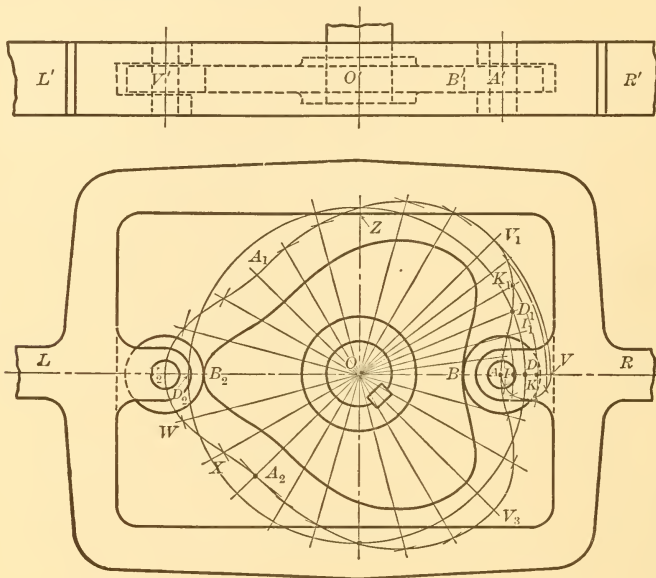

FIG. 53.—PROBLEM 13, SINGLE-DISK YOKE CAM

in the first 180° , otherwise the follower will have a greater motion than that which was assigned to it.

To illustrate this second case, assume that item (c) had been changed in the data for Problem 13 so as to specify that the follower should remain at rest while the cam turns 45° . Then the pitch surface of the cam for the first 180° would have been AV_1A_1C , Fig. 54, instead of $AV_1A_1V_2$. The diametral distance AC would then have been the distance between roller centers, and would have been also the distance used in determining the complementary pitch surface CE_1A_3A which, it will be noted, approaches closer to O than does AV_1C . When E_1 of the complementary surface

reaches the center line OD , the center A of the roller will be at E and the roller will have traveled the distance AE in addition to the travel AV which was assigned. Furthermore, the pressure angle will be very high when F crosses the line OD_2 . With the data which gives the pitch surface AV_1C , the yoke follower will move just twice the assigned distance. This double motion will not be continuous, as the follower will be at rest for a definite period represented by A_1C . Even if the data were such that A_1 should fall at C there would be a momentary period of rest for the follower at the middle of its stroke.

Summing up, the desired travel, pressure angle, and follower velocity will be obtained in single-disk yoke cams, only when the data are such as to have the follower at the extreme opposite ends of its stroke at the zero and 180° phases. In other cases increased travel, increased pressure angle, and irregular follower velocities will have to be considered.

All of the limitations of the single-disk yoke cam may be avoided by using the double disk cam as illustrated in Problem 14.

119. EXERCISE PROBLEM 13a. Required a single-disk radial cam to operate a yoke follower with a maximum pressure angle of 30° :

- In 6 units in 60° turn of the cam on parabola curve.
- Out 6 " " 45° " " " " " " " "
- At rest for 30° " " " " " " " "
- In 6 units in 45° " " " " " " " "

120. PROBLEM 14. DOUBLE-DISK YOKE CAM. Required a double-disk cam to operate a yoke follower with a maximum pressure angle of 30° :

- To the right 6 units in 150° turn of the cam, on the crank curve.
- To the left 6 units in 90° turn of the cam, on the crank curve.
- To remain stationary for 120° turn of the cam.

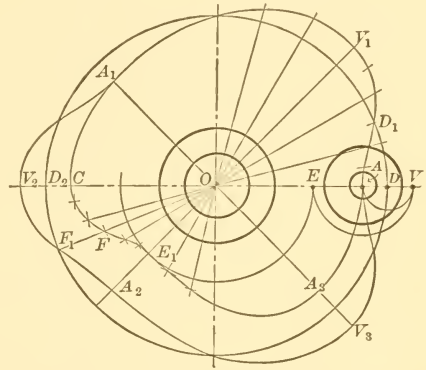

FIG. 54.—ILLUSTRATING LIMITED APPLICATION OF SINGLE-DISK YOKE CAM

121. The detail of construction for the primary disk is the same as in previous problems involving radial cams. In this problem, then, the radius of the pitch circle is $6 \times 2.72 \times 4 \times \frac{1}{3.14} \times \frac{1}{2} = 10.4$ units and this is laid off at $O D$, Fig. 55. The forward driving pitch surface, $A H_1 V_1 I_1 A$, is constructed in the regular way as indicated by the construction lines.

122. The diameter $D C$ of the pitch circle is next taken as a constant and its length is laid off on diametral lines from successive

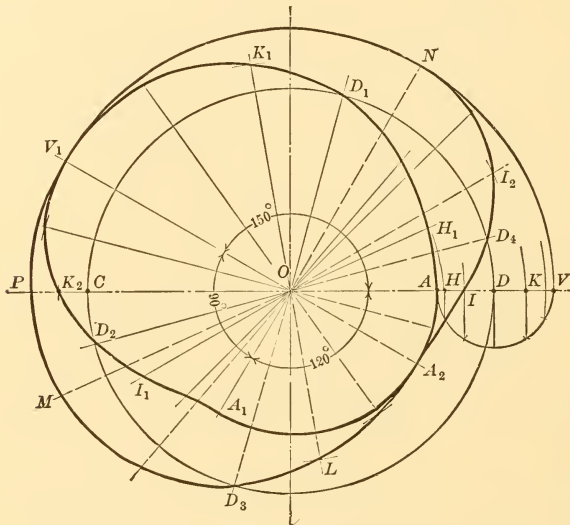

FIG. 55.—PROBLEM 14, DOUBLE-DISK YOKE CAMS, DETAIL CONSTRUCTION

points on the primary pitch surface, thus giving the secondary or return pitch surface. For example, the point P on the secondary surface is found by making $A P = D C$; the point M by making $H_1 M = D C$ This second cam disk has a pressure angle of 30° at D_4 , the same as the primary disk has at D_2 . Had any diametral length other than $D C$ been taken in this problem as a constant for constructing the second cam, the pressure angle at D_4 would have been greater or less than the assigned 30° . It does not follow that the diameter of the pitch circle should be used as a constant for generating the complementary cam. The determining factor, in selecting a constant diametral length is that the maximum pressure angle on the second cam should not exceed the assigned value.

123. To avoid intricate line work, only the detail drawing for the construction of the pitch surfaces for this problem is shown in Fig. 55. The pitch surfaces are then redrawn in Fig. 56 and the working surfaces and the yoke constructed.

The working surface of the primary or forward-driving cam is shown at $B E F G B$, Fig. 56, and is constructed in the same way as

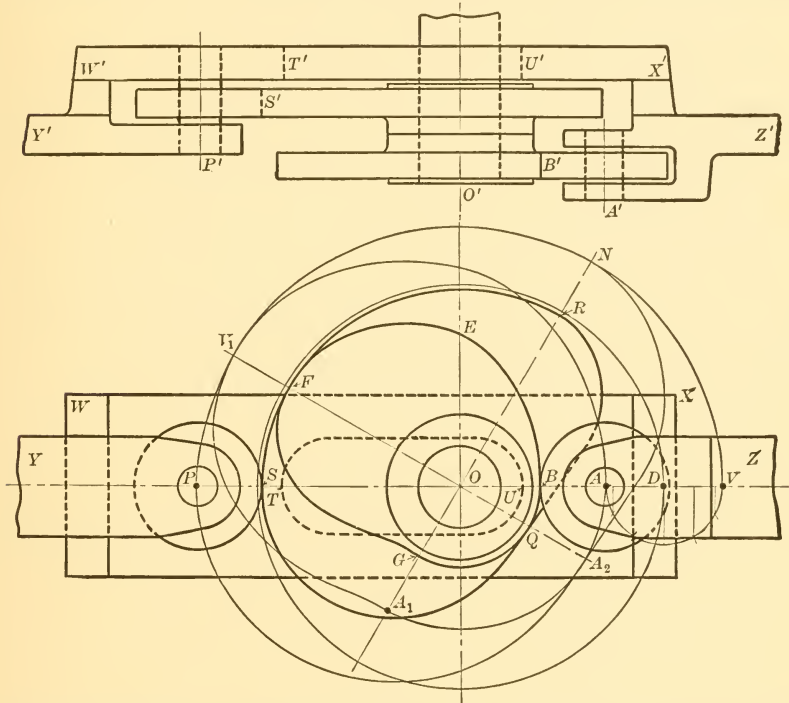

FIG. 56.—PROBLEM 14, DOUBLE-DISK YOKE CAMS SHOWING STRAP YOKE AND ROLLERS

in previous problems by drawing it as an envelope to successive roller positions. The working surface of the return cam is shown at $S Q R S$. A special caution to be observed at this point is that the *working surface* of the second cam cannot be obtained directly from the working surface of the first cam by using the diametral constant; the second cam pitch surface must be obtained first.

124. The form of yoke in yoke cams may vary, as illustrated for example by the box type which encloses the cam, Fig. 53, and by the strap type, Fig. 56. In the latter illustration the strap $W X$ has a longitudinal slot $T U$ permitting it to move back and forth astride the shaft without interference. The guide arms of the

yoke are shown at Y and Z . In all yoke constructions it is desirable to have all the forces acting in as nearly a straight line, or in a plane, as possible. In Fig. 53 this is obtained, as may be noted in the top view where the longitudinal center lines of cam disk, cam roller, yoke and yoke guides are all in the same plane. In Fig. 56 the yoke guides, Y' and Z' , are placed in a line lying between the cam disks, B' and S' , so as to have the forces balanced to a greater degree than they would be if the guides were in line with the strap $W' X'$.

125. EXERCISE PROBLEM 14a. Required a double-disk cam to operate a yoke follower with a maximum pressure angle of 30° , as follows:

- (a) To the right 4 units in 90° on the parabola base.
- (b) Dwell for 30° .
- (c) To the right 4 " " 105° " " " "
- (d) " " left 8 " " 135° " " " "

126 PROBLEM 15. CYLINDRICAL CAM WITH FOLLOWER THAT MOVES IN A STRAIGHT LINE. Required a cylindrical cam to operate a reciprocating follower rod:

- (a) To the right 4 units in 120° on the crank curve.
- (b) " " left 4 " " 120° " " " "
- (c) " dwell 120° .

The maximum surface pressure angle to be 30° .

127. The size of cylinder is found by a computation similar to that for radial cams, and in this problem the radius of the cylinder is,

$$4 \times 2.72 \times 3 \times \frac{1}{3.14} \times \frac{1}{2} = 5.2 \text{ units.}$$

This distance is laid off at $O' A'$ in Fig. 57, and the circle drawn. The distance $A V$, the travel of the follower, is laid off equal to 4 units and subdivided, according to the crank circle, at $H, I \dots$. The radius of the follower pin is assumed as at $A S$ and this distance is laid off at $S C$, thus locating the edge of the cylinder. Make $V D$ equal to $A C$. The circle representing the cylinder is next divided into three 120° divisions at $A', M',$ and Q' , as specified.

$A' M'$ is divided into six equal parts by the points $H', I' \dots$ which are projected over to meet the vertical construction lines through $H, I \dots$ at $H_2, I_2 \dots$. The latter points mark a curve on the surface of the cylinder. This curve is a guide for the center of the tool which cuts the groove. The finding of this curve and the construction of the follower pin and rod constitute the remaining essential work on this problem. If it is desired to show the groove

itself, the directions in paragraph 134 will give an approximate method. The follower pin is attached to a follower rod X which is guided by the bearings Y and Z . The assigned pressure angle of 30° is shown in its true size at DJG ; JD being parallel to the direction of motion of the follower rod, and JG being a normal to the cutting-tool curve $MNJ P$ In general, the pressure angle will not show in its true size, and if it is then desired to illustrate it, the cylinder may, in effect, be revolved until the correct point of the cutting-tool curve is projected on the horizontal center line. The exact point E where the cutting-tool curve comes tangent to the bottom line of the cylinder may be found by locating E_1 relatively to K_1 and L_1 , the same as E' is located relatively to K' and L' , and projecting E_1 down to E .

A small clearance is allowed between the end B' of the pin and the inner surface of the groove, which is represented by the dash circle passing through F' .

128. REFINEMENTS IN CYLINDRICAL CAM DESIGN. It will be noted that the "maximum surface pressure angle" was given in the data for this problem instead of the term "maximum pressure angle" that has been used thus far. The reason for this is that the pressure angle varies along the length of the pin and is always greatest at the outer end, that is, at the point B in Fig. 57. This is not important in most practical cases. Further, the term "pitch cylinder" is not mentioned in the simple form of practical construc-

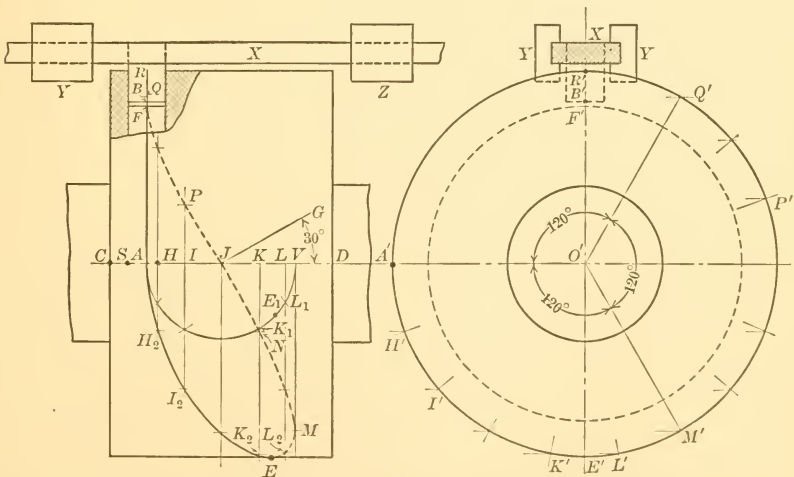

FIG. 57.—PROBLEM 15, CYLINDRICAL CAM WITH FOLLOWER SLIDING IN A STRAIGHT LINE

tion here used. Since the pitch cylinder should pass through the point where maximum pressure angle exists, the pitch cylinder in cams of this type would be one having a radius $O' B'$. The pitch surface of the cylindrical cam would be a warped surface, known as the right helicoid, and the intersection of this surface with the surface of the cylinder is the curve $R A E P R$ and is the guide curve for the cutting tool in milling out the groove for the pin. The sides of the groove are the working surfaces of the cam; they are indicated in the sectioned part of the front view of Fig. 57.

More exact methods for drawing the sides of the groove in a cylindrical cam, together with a more exact method for determining the maximum pressure angle, involve a knowledge of projections and an intricacy in drawing that make such work a proper subject for advanced study, and it will therefore be omitted in this elementary treatment, as it is totally unnecessary in most practical work.

129. EXERCISE PROBLEM 15a. Required a cylindrical cam to operate a sliding follower rod, with a maximum pressure angle of 40° :

- (a) 6 units to the right in 90° on the parabola base.
- (b) 6 " " " left " 270° " " " " "

130. PROBLEM 16. CYLINDRICAL CAM WITH SWINGING FOLLOWER. Required a cylindrical cam to operate a swinging follower arm:

- (a) To the left 40° in 120° turn of the cam on the crank curve.
- (b) " " right 40° " 120° " " " " " " " "
- (c) Dwell for 120° turn of the cam.

The length of the follower arm is to be 9 units and the approximate maximum pressure angle is to be 30° .

131. The diameter for the cylindrical surface is found in the same manner as the diameter of the pitch circle in radial periphery cams. The data in this problem do not give directly the travel of

the follower and so this value must be found first. The chord of a 40° arc having 9 units radius will be

$$9 \times 2 \times \sin 20^\circ = 9 \times 2 \times .342 = 6.2 \text{ units.}$$

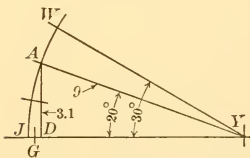

FIG. 58.—DETERMINING FOLLOWER TRAVEL IN SWINGING ARMS FOR COMPUTING PITCH DIAMETER

If a trigonometrical table is not at hand the arc may be drawn out as in Fig. 58 where half the given angle is laid out at AYJ by the simple expedient of subdividing a 30° arc by means of a dividers. The half chord AD is drawn and measured. It is equal to 3.1 units, thus making the chord of the whole arc of travel equal to 6.2 units.

This value is used in obtaining the diameter of the surface of the cylinder as follows:

$$6.2 \times 2.72 \times 3 \times \frac{1}{3.14} = 16.12 \text{ units.}$$

The circle $A'Q'M'$, Fig. 59, is drawn with a radius of 8.06 units.

132. The 120° angles assigned in the data are next laid out but not from the center line OR' as in previous problems. In mechanisms of all kinds where there is a swinging follower, it is a rule, unless otherwise specified, that the swinging pin should be the same dis-

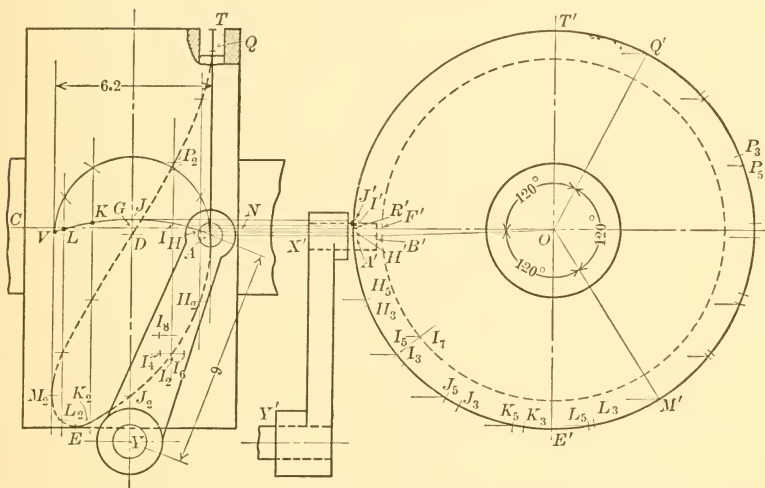

FIG. 59.—PROBLEM 16, CYLINDRICAL CAM WITH SWINGING FOLLOWER ARM

tance above a center line at the middle of its swing as it is below at the two extremities of its swing. In this case, then, the point G , Fig. 58, will be marked midway between J and D and the distance GJ laid off at GJ in Fig. 59. Y will be the center of swing of the follower arm and the arc of swing of the follower pin will be AJV . J will be as much above the center line as A and V are below. The practical advantage of this detail in the layout is that it gives a maximum bearing length between the follower pin and the side of the groove.

133. The arc AJV , Fig. 59, is next divided at the points marked $H, I \dots$ according to the crank curve assignment, and vertical construction lines are drawn through these points.

The point A is now projected to A' and the radial line, $A'O$, is drawn. This becomes the base line from which to lay off the three

assigned timing angles of 120° , as shown at $A' O M'$, $M' O Q'$, and $Q' O A'$. The arc $A' M'$ is next divided into the desired number of equal construction parts, as at H_3, I_3, J_3, \dots .

When H_3 reaches A' , the pin A will have swung not only over to H , but it will have moved up the distance $A' H'$ measured on the surface of the cylinder. Therefore, when H_3 reaches A' , it is the line through H_5 ($H_3 H_5 = A' H'$) on the groove center line that will be in contact with the pin center line. For this reason H_5 , instead of H_3 , is projected over to meet the construction line at H_2 . This latter point is on the guide curve for the cutting tool on the surface of the cylinder. Other points are found in the same way. Time may be saved by marking the points $A' H' I' J'$ on the straight edge of a piece of paper and transferring these marks at one time so as to obtain the points $I_5, J_5, \dots, P_5, \dots$.

134. If it is required to show the surface bounding lines of the side of the groove it may be done quickly, although approximately, by laying off on a horizontal line, as at I_2 , the points I_4 and I_6 at distances equal to the radius of the pin. These will represent points on the curve. If it is required to show the bottom lines of the groove it may be done by projecting from I_7 and finding, for example, the point I_8 in the same way as I_4 was found.

135. EXERCISE PROBLEM 16a. Required a cylindrical cam to operate a swinging follower arm:

(a) To the right 6 units (measured on chord of follower pin arc) while cam turns 150° .

(b) Dwell while cam turns 120° .

(c) To the left 6 units while cam turns 90° .

The follower arm to be 8 units long and its rate of swinging to be controlled by the crank curve with a maximum approximate pressure angle of 40° .

136. CHART METHOD FOR LAYING OUT A CYLINDRICAL CAM WITH A SWINGING FOLLOWER ARM. This method is illustrated in Figs. 60 and 61. The data in this problem will be taken the same as in Problem 16, namely, that a follower arm of 9 units length shall: Swing through an angle of 40° to the left while the cam turns 120° ; through the same angle to the right while the cam turns 120° ; on the crank curve in both directions; remain stationary while the cam turns 120° . The maximum pressure angle is to be approximately 30° .

137. To find the length of the chart, the chord that measures the arc of swing of the follower pin is first determined to be 6.2

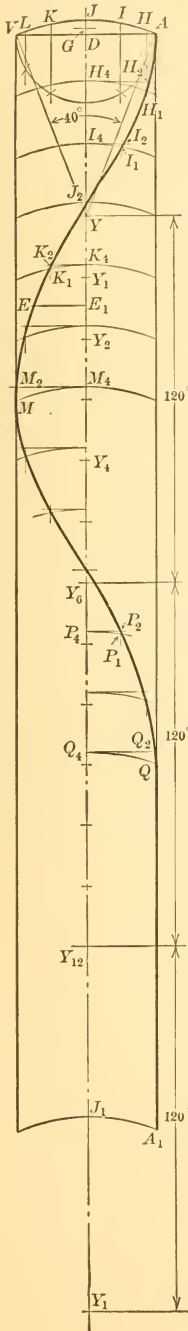

FIG. 60.—CHART FOR LAYING OUT CYLINDRICAL CAM WITH SWINGING FOLLOWER

units as explained in paragraph 131. The length of chart is

$$6.2 \times 2.72 \times 3 = 50.6 \text{ units,}$$

and this is laid off at $J J_1$, Fig. 60. The length of the follower arm is then laid off at $J Y$, and the follower-pin arc $A V$ drawn. This arc is subdivided at $H, I \dots$ according to the crank curve. The distance $Y Y_6$ is then laid off to represent 120° and its length will be equal to one-third the length of the chart. As many construction points as were used from A to V are then laid off between Y and Y_6 . With these as centers and $Y A$ as a radius draw a series of arcs to which the points $H, I \dots$ are projected, thus giving the base curve through the points $H_1, I_1 \dots$. Tangent to the series of arcs on the chart draw straight lines and mark the intercepts $H_4 H_2, I_4 I_2 \dots$.

138. Upon completing the chart, the surface of the cam is drawn as in Fig. 61, with a diam-

eter $E' T' = \frac{50.6}{3.14} = 16.12$. The width $C N$ of

the cylinder may be taken equal to the chord $A V$ of the arc of swing of the follower pin, plus twice the diameter of the pin.

139. The simplest general plan for transferring the cam chart to the surface of the cam is to consider the chart lines to be on a strip of paper, and that this paper is simply wound around the cylindrical surface of the cam, starting the point G of the chart at G on the center line of the cam. G on the chart is midway between J and D . Then the points $H_2, I_2 \dots$ of the base curve in Fig. 60 will fall at H_2, I_2 , in Fig. 61, giving the surface guide curve for the center of the cutting tool.

140. The detail necessary to actually locate the points H_2, I_2 in Fig. 61 is accomplished by projecting J to J' and laying off the as-

signed 120° divisions, and also the subdivisions from this latter point. The 120° divisions are shown at M', Q', J' ; the equal subdivisions at $H_3 I_3$ From these latter points, lines are projected to the front view and the lengths $H_4 H_2, I_4 I_2$ are transferred

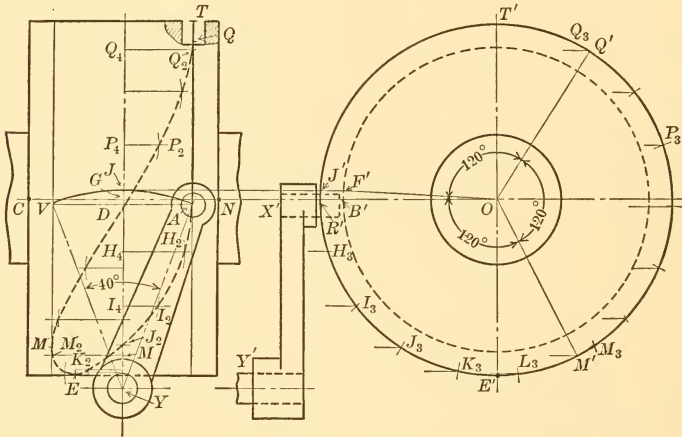

FIG. 61.—CYLINDRICAL CAM WITH SWINGING FOLLOWER DRAWN FROM CHART

from Fig. 60. To find the point of tangency at E , make $K_4 E_1$ of Fig. 60 equal to $K_3 E'$ of Fig. 61, then draw $E_1 E$ in Fig. 60 and lay off this distance from the center line $G Y$ in Fig. 61, thus giving the point E . To find the point of tangency at M , lay off at $M' M_3$ a distance equal to the chart distance from M_2 to M in Fig. 60 and project M_3 of Fig. 61 to M .

SECTION IV.—TIMING AND INTERFERENCE OF CAMS

141. In machines where two or more cams are employed it is generally necessary to lay down a preliminary diagram showing the relative times of starting and stopping of the several cams, in order to be assured that the various operations will take place in proper sequence and at proper intervals. The same preliminary diagram is also used to avoid interference and to make clearance allowances for follower rods whose paths cross each other.

142. PROBLEM 17. CAM TIMING AND INTERFERENCE. Required two cams that will operate the follower rods *A* and *E*, Fig. 62, lying in the same plane, so that:

(a) Rod *A* shall move 16 units to *D*, dwell for 30° , return 8 units to *B* and again dwell 30° , all to take place in 180° turn of the cam. The cam to produce the same motions in the second 180° but in reverse order.

(b) Rod *E* shall cross path of rod *A* and move 4 units beyond it and back again during the time that rod *A* is moving from *D* to *B* to *D*.

All motions to be on the crank curve with maximum pressure angles of 40° .

143. Before taking up the solution of this problem in detail it should be noted: 1st, that any convenient type of cam may be used in problems of this kind;

2d, that usually only general motions of followers or objects are given in the preliminary data, as above, and that the cam designer must supply data and restate the problem in terms of angles for each of the movements after studying the preliminary data with the aid of a timing diagram.

144. The first step leading to a restatement of the problem is to determine the number of degrees in which rod *A* may move the

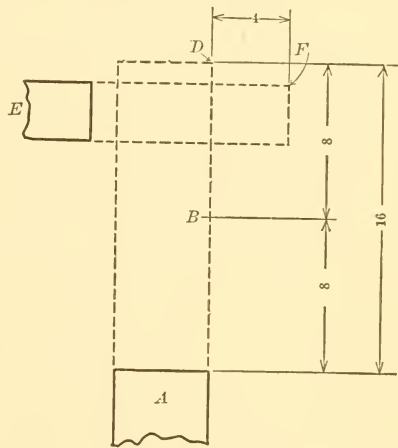

FIG. 62.—PROBLEM 17, PRELIMINARY LAYOUT OF DATA FOR PROBLEM IN CAM INTERFERENCE

16 units, and also the number of degrees in which it may move the 8 units in order that the pressure angle will be 40° in both cases. Since there are two 30° dwells in the first 180° there will be 120°

left for the two motions of which the first motion will require $\frac{16}{24}$ of 120° or 80° , and the second, 40° . The length of chart for cam *A* may now be computed as $16 \times 1.87 \times \frac{360}{80} = 134.6$ and laid off as at $A A_1$, Fig. 63. The height of the chart *AD* is 16 units. The chart is next divided into degrees of any convenient unit, $0, 10^\circ, 20^\circ \dots$ being used in this case. For the present the base line may be made up of a series of straight lines as at $A D_1, D_1 D_2, D_2 B_1 \dots$

145. The amount of clearance between the moving arms must now be decided upon. Let it be the designer's judgment that the end of the follower rod *E* should lie at rest 1 unit to the left of rod *A* as shown in Fig. 64, and that rod *E* should not begin to move until the rod *A* is one unit out of the way. Then *A* will be at *O*, Fig. 64, moving down, when *E* starts, assuming the rod *E* to be 3 units wide and that it is so placed that its top edge is one unit below *D*. The point *C* is then 5 units from the top of the stroke and if this distance is laid off in Fig. 63, as shown, the line $C C_1$ is obtained cutting the crank curve, which should now be drawn at *C*. *C* is at the 133° point and this, then, is the time when the follower *E* should start to move.

146. The total motion for rod *E* is $4 + 5 + 1 = 10$ units, assuming width of rod *A* to be 5 units. The time during which this motion can take place, outward, is $180^\circ - 133^\circ = 47^\circ$ as

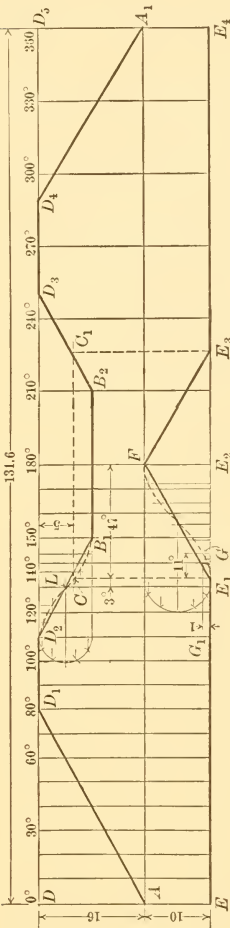

FIG. 63.—PROBLEM 17, TIMING DIAGRAM FOR AVOIDING INTERFERENCE OF CAMS

represented at $E_1 E_2$, Fig. 63. If the crank curve $E_1 F$ is now drawn it will be intersected by the one-unit clearance line $G_1 G$ at *G* which represents, in this case, a rotation of approximately 11° of the cam that drives rod *E*. The total clearance for the two rods which cross each

other's paths is now found to be 3° for cam follower A and 11° for cam follower E , or 14° of the machine cycle. These clearances are indicated in Fig. 63. If it is the judgment of the designer that errors in cutting keyways and in assembling, and that the wear of the parts will fall within these limits, the cams may now be drawn.

147. The cam chart for cam E was made the same length as

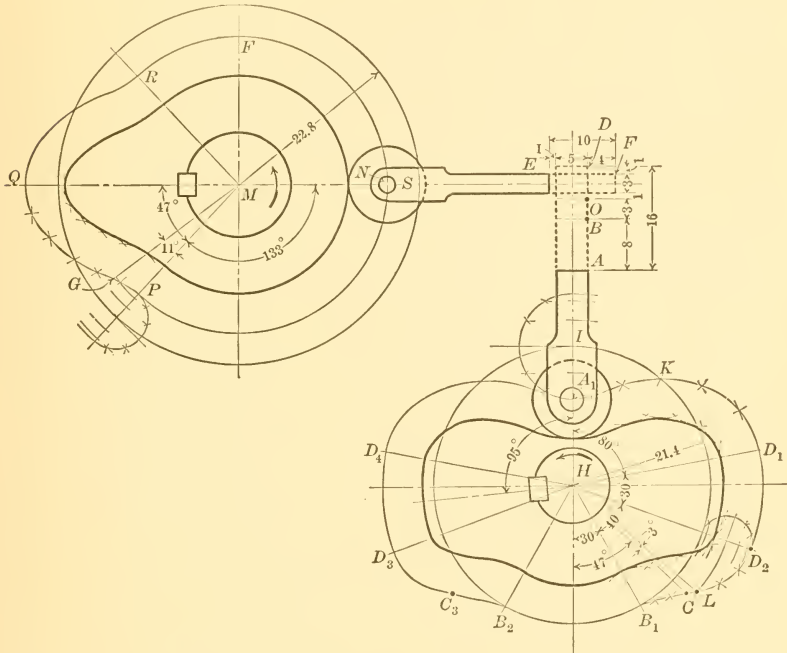

FIG. 64.—PROBLEM 17, DESIGN FOR DEFINITE TIMING AND NON-INTERFERENCE OF CAMS OPERATING IN SAME PLANE

the chart for cam A in order to make clearance allowance. The true length of this chart, for a 40° pressure angle, would be:

$$10 \times 1.87 \times \frac{360}{47} = 143.2 \text{ units,}$$

instead of 134.6 as now drawn. If an exact clearance allowance in degrees were required, it would be necessary to redraw the crank curve E_1F , making the distance E_1E_2 equal to $\frac{47}{360}$ of 143.2. It is now $\frac{47}{360}$ of 134.6. With a new and exact drawing the crank curve E_1G

would not rise quite so rapidly and the intercept at G would show a small fraction over the 11° taken above. In some problems where the lengths of the true charts differ considerably it may be necessary to redraw this part of the base curve to be sufficiently accurate in obtaining the clearance in degrees.

148. The radius of the pitch circle for the cam operating rod A will be $\frac{134.6}{6.28} = 21.4$ units as drawn at HI , Fig. 64. The pitch surface of the cam and the working surface are drawn in the same way as the ordinary radial cams in previous problems. The length of the rod A_1A may be assumed.

The radius for the pitch circle for the cam operating rod E will be $\frac{143.2}{6.28} = 22.8$ and this is laid off at MS . The location of M and the length of the rod NE will either enter into the layout of the framework of the machine in a practical problem, or will be determined

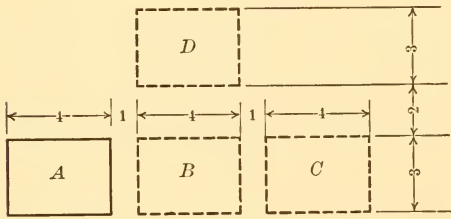

FIG. 65.—PROBLEM 17a, DIAGRAM SHOWING APPLICATION OF DATA

by the framework if previously laid out. In the present case it will only be necessary, in determining the length of rod NE and the position of M , to make certain that the shafts M and H are sufficiently far apart to keep the cams from striking when turning.

149. LOCATION OF KEYWAYS. It is important to locate the keyway exactly by giving its position in degrees so as not to destroy the clearance values already made. Since the working surfaces of cams frequently approach close to the hub or shaft it is a good plan to place the keyway at the center of the longest lobe of the cam, as illustrated in both cams.

150. EXERCISE PROBLEM 17a. Assume a stack of blocks at A , Fig. 65. Required that the bottom block shall be delivered with one stroke at C , the next block at D , being moved first to B and then to D , the next block at C , the next at D , etc. Let the sizes of the blocks and the distances they must be moved be as shown in Fig. 65. Lay out cam mechanism to secure this result, keeping the maximum pressure angle at 30° .

SECTION V.—CAMS FOR REPRODUCING GIVEN CURVES OR FIGURES

151. PROBLEM 18. CAM MECHANISM FOR DRAWING AN ELLIPSE. Required a cam mechanism that will reproduce the ellipse $A C B D$ in Fig. 66, the marking point to move slowly at the extremities A and B of the major axis and rapidly at C and D , the rate of increase and decrease of velocity being uniform.

152. Divide $A C$ into three parts which are to each other as 1, 3, and 5; $C B$ into three parts which are as 5, 3, and 1 . . . in order that the marking point shall move through increasing spaces in equal times in moving from A to C For greater accuracy $A C$ would be divided into a greater number of parts.

153. In devising the mechanism assume that the marking point shall be at the end of a rod which shall be controlled by two component motions that are horizontal and vertical, or nearly so. This suggests the rod $A E F$, with marking point at A , with horizontal motion supplied from a bent rocker attached at F and with vertical motion supplied from a reversing straight arm rocker $L K J$, attached through a link $E J$ at the point E . The lengths of the links and of the arms of the rockers, and the positions of the fixed centers of the rockers will have to be assumed, the lengths of the arms and links being such that none of them will have to swing through more than 60° . With more than 60° swing the angle between an arm and a link is liable to become too acute for smooth running. Where rocker arms are connected to links the ends of the rocker should, in general, swing equal distances above and below the center line of the link's motion, as for example, the points F and G on the arc of swing of F should be as much above the line $A M$ as the point B is below. Also the arc $B J G$ should swing equally on each side of $J T$ in order to secure best average pressure angles for the mechanism.

154. Let each of the rocker arms be assumed to be controlled by single-acting radial cams. The center of roller H will be required to swing on an arc $G H$ which, continued, passes through M . This gives small pressure angles while A is traveling to B , especially when A is at C and is moving fastest. It gives large pressure angle, however, while A is traveling from B to D to A . If A is assumed to do heavy work along $A C B$ and to run light along $B D A$ this is the

better arrangement. If A did the same work on both strokes it would be better to place the rocker arm GH so that H and θ rested on a radial line. The center of roller L will be assumed to travel on an arc whose extremities are on a radial line, or nearly so.

With AF as a radius and $A, 1, 2 \dots$ as centers, strike short arcs intersecting $F\theta$ at $F, 1, 2 \dots$ numbering the arcs as soon as drawn to avoid confusion later on. Lay off points on $H\theta$ corresponding to those on $F\theta$.

155. Inasmuch as the point H does not move in accordance with the law of any of the base curves no precise computation can be made for the size of the pitch circle for any given pressure angle and it may be omitted. Instead, a minimum radius MH of the pitch surface may be assumed. If it is desired to control the pressure angles it may be done by first constructing the pitch surface, $H VW$, and then measuring the angles at the construction points. Some of these are shown in Fig. 66, at $H, 3, \theta$, and 8 , and are 20° , -12° , 48° , and 57° , respectively. If these angles should prove unsatisfactory a larger pitch circle, or a differently proportioned rocker, may be used. Or, an approximate computation for radius of pitch circle by the method which is explained to advantage in connection with the next problem, paragraphs 164 and 165, may be used.

156. To construct the second cam, take the distance AE as a radius and $A, 1, 2 \dots$ as centers and mark the points $E, 1, 2 \dots$. Again, with the latter points as centers and EJ as a radius, mark the points $J, 1, 2 \dots$ and transfer these to $L, 1, 2 \dots$. With the latter points marked, the pitch surface of the second cam, PQR , is constructed in the same way as was the first cam.

The angle between the keyways, marked $39\frac{1}{2}^\circ$ in Fig. 66, must be carefully measured and shown on the drawing.

157. EXERCISE PROBLEM 18a. Required a cam mechanism that will draw the numeral 8, the marking point moving with uniform velocity.

158. PROBLEM 19. CAMS FOR REPRODUCTION OF HANDWRITING. Required a cam mechanism to reproduce the script letters *St e*.

159. The first step in the solution of this problem is to write the letters carefully, for if the machine is properly designed it will reproduce the copy exactly as written. The copy is written at **A** in Fig. 67.

160. The next step is to decide on the kind of mechanism and the type of cams to be used, for the problem may be solved by a number of different combinations. The mechanism for this problem

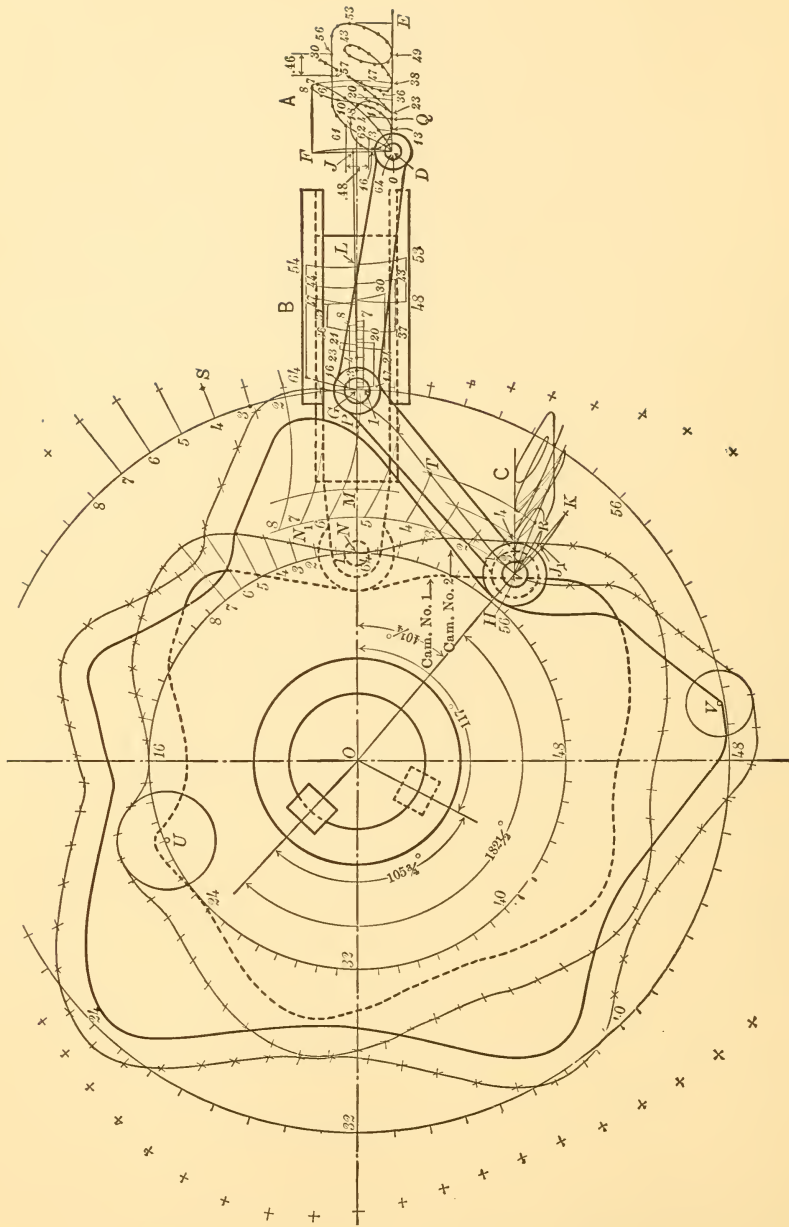

FIG. 67.—PROBLEM 19, CAMS FOR REPRODUCING SCRIPT LETTERS, ETC.

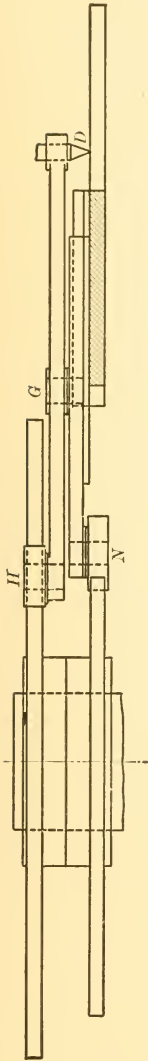

FIG. 68.—PROBLEM 19, FRONT VIEW OF CAM MECHANISM

will consist of two radial single-acting cams mounted on one shaft, and a swinging rocker arm mounted on a pivot which is moved forth and back on a radial line as shown in Fig. 67. This mechanical combination is selected for this problem because it involves methods of construction not used in any of the preceding problems.

161. The actual work of construction is started by marking off a series of dots along the lines of the entire copy, as shown at **A**, and marked from zero to 64. Inasmuch as there is some latitude in the spacing, and consequently in the number of these dots, as will be explained presently, it is advisable to use a total number of dots whose least factors are 2 and 2, 2 and 3, or 2 and 5. This is not essential but it will facilitate the work later on.

162. The matter of placing the dots is perhaps the most important item of the entire problem, for on this depends the size of the roller and smooth action. In fact, with some methods of spacing, no roller can be used at all and a sharp V-edge sliding follower will have to be used if true reproduction is desired.

The basic considerations in selecting the points are:

First, that a point should be located at the extreme right and extreme left of each right and left throw, as at $0 - 7, 7 - 16, 16 - 20 \dots$ in Fig. 67, **A**, and at the top and bottom of each swing, as at $0 - 8, 8 - 13, 13 - 18 \dots$; and,

Secondly, that the marking point should start slowly and come to rest gradually on each stroke, considering both of the component directions of its motion at the same time. On account of this

it is impossible to secure ideal conditions at all times and compromises must frequently be made. For example, the component motions of the marking point *D* are: First, a horizontal one due to Cam No. 1; and secondly, a vertical curvilinear one due to Cam No. 2 and the rocker arm *HGD*. The intermediate points $0-7$ on the upper swing of the letter *S* are so selected as to give increasing and

decreasing spaces in the horizontal projections on DE , and the same points, together with point S , are selected at the same time so as to give increasing and decreasing spaces when projected onto the arc DF . Each space between a pair of adjacent numbers represents the same time unit. On this basis the entire spacing of the copy is done.

163. With each of the points in the group at **A**, Fig. 67, as centers, and with a radius, DG , mark very carefully the corresponding points on GL in group **B**. To avoid confusion it is essential here to adopt some method of identifying points so marked for later reference. A satisfactory method is shown at **B**, all the motions to the right being indicated below, and the motions to the left, above GL .

164. The sizes of the cams are to be next computed. To do this select the largest horizontal space in section **A**. This is found between 56 and 57 and is equal to $.46$ of the unit of length that happened to be selected in this problem. Assuming that the marking point moves with uniform velocity over this distance, and that a pressure angle of 40° is suitable in this instance where no heavy work is done, the factor of 1.19 is taken from the table in paragraph 30. Since there are 64 time units the length of circumference of pitch circle for Cam No. 1 will be

$$.46 \times 1.19 \times 64 = 35.03, \text{ and the radius } 5.58.$$

165. Before calculating the size of Cam No. 2 the length of the rocker arm GH must be decided upon and this will be taken in this problem at 5 units, the same as the arm GD . Then the total swing of the follower point H will be HK , equal to DF , and the greatest swing in any one direction in any one time unit will be during the periods $10-11$ and $61-62$, shown at **A**, Fig. 67, both equal to $.48$ units. Making the same computation as for Cam No. 1,

$$\frac{.48 \times 1.19 \times 64}{3.14 \times 2} = 5.82$$

equals the pitch radius of Cam No. 2.

166. The position of the cam shaft O relatively to the pivot arm G depends on what is desired for the position of the arc HK with reference to the cam center. If it is desired that the points H and K shall be on a radial line from the center of the cam, which gives best practical average results for both in and out strokes, proceed as follows: Draw chord DF at **A** in Fig. 67; bisect it at J and measure distance GJ which is 4.93 units. Then the distance

GO will be the hypotenuse of a right angle triangle of which one side is 4.93 and the other 5.82. This may be separately drawn and the length of the hypotenuse found graphically or it may be figured as follows:

$$GO = \sqrt{5.82^2 + 4.93^2} = 7.63.$$

167. The pitch circles for both cams may be taken in problems of this kind to pass through the midpoint of the total travel. Then OM is the radius of the pitch circle of Cam No. 1 and NP the total range of travel of the roller center; and OJ_1 is the radius of the pitch circle of Cam No. 2 and HK the total range of travel of the roller center relatively to G .

168. To find points on the pitch surface of the cams proceed in the usual way for Cam No. 1, by dividing the circle whose radius is ON into as many equal parts as there were dots on construction points at **A**. Draw radial lines, and on these lay off the distances secured from **B** in Fig. 67; for example, the distance $3N_1$ is laid out equal to $G3$. The point N_1 , and other points secured in similar manner, will lie on the pitch surface of Cam No. 1.

169. The construction of the pitch surface for Cam No. 2 is different from that of Cam No. 1, and is different also from anything done in the preceding problems. In this case the resultant motion of the arm GH is made up of rectilinear translation and rotation and both components must be considered in laying out the pitch surface, for example, as follows: With GH as a radius and point 4 of **B** as a center draw an arc intersecting the horizontal line through H at 4. Then when G is moved to 4 by Cam No. 1, H would be at 4 if the rectilinear component motion due to cam No. 1 were the only one acting. During the period represented by $G4$, however, Cam No. 2 must move the rocker arm through an arc $Q4$, shown at **A**, and this arc must now be laid off at 4 R . The point R is then revolved to its proper position at T as follows: Divide the circle OG into sixty-four equal parts. This is readily done in this problem because G is taken on the same radial line with N and the radial divisions already made on the circle having ON for a radius need only be extended. Lay off the distance $G4$ at 4 S . With S as a center and GH as a radius draw the arc 4 T . Then T will be a point on the pitch surface of Cam No. 2.

170. Having determined the pitch surfaces of the two cams the largest possible roller for each is found by searching for the shortest radius of curvature on the working side of each pitch surface. For

from F to the next step beyond B . Assume that there are 11 steps from F to G , then go forward 11 steps on the arc to K . Divide the large part of the circle $K D B$ into eighty parts by the process of subdivision with the dividers as indicated by the divided angles 80, 40, 20, 4, 2, and 1, in Fig. 69. Then BH is $\frac{1}{80}$ of $K D B$, or $\frac{1}{87}$ of the entire circle, and the length BH will go exactly seven times into the arc BK . In this work nothing is said of the use of a protractor for laying off a large number of small subdivisions on a circle, although it may be used. The process of subdivision, however, always using the small dividers, gives automatically remarkably accurate results.

SECTION VI.—ADVANCED GROUP OF BASE CURVES FOR CAMS

173. THE PREVIOUS SECTIONS OF THE BOOK have dealt with the simpler base curves which are in common use, and with their elementary application to various types of cams. In the present section the simpler forms of base curves are further considered, other forms are treated, and new ones are proposed; all are brought together for comparisons.

174. COMPLETE LIST OF BASE CURVES. The base curves which have been used in the previous sections are:

Straight Line, Figs. 22 and 78.

Straight-Line Combination, Figs. 23 and 82.

Crank Curve, Figs. 24 and 86.

Parabola, Figs. 25 and 90.

Elliptical Curve, Figs. 26 and 102.

Other base curves which will be considered in following paragraphs are:

All-Logarithmic Curve, Fig. 70.

Logarithmic-Combination Curve, Fig. 74.

Tangential Curve, Case 1, Fig. 94.

Circular Curve, Case 1, Fig. 98.

Cube Curve, Case 1, Fig. 106.

Circular Curve, Case 2, Fig. 110.

Cube Curve, Case 2, Fig. 114.

Tangential Curve, Case 2, Fig. 118.

175. COMPARISON OF BASE CURVES, THEIR APPLICATIONS, AND THEIR CHARACTERISTIC MOTIONS. Figs. 70 to 121 illustrate:

(1) The forms of each of the base curves, Column 1.

(2) The form and true relative size of cam, all having the same data, Column 2.

(3) The velocity diagram for each cam, Column 3.

(4) The acceleration diagram for each cam, Column, 4.

176. THE DATA FOR ALL OF THE CAMS and diagrams illustrated in Figs. 70 to 121 are as follows:

(a) The follower to rise 1 unit in 60° turn of the cam,

(b) “ “ “ fall 1 unit in 60° “ “ “ “

(c) The follower to remain at rest for 240° turn of the cam,

(d) “ maximum pressure angle to be 30° .

177. ALL OF THE CAM CHARTS illustrated in Column 1, Figs. 70 to 121, include only the first item in the above data and they show, therefore, only one-sixth of their full length. In Column 2 the entire cam is shown in each case, and it is drawn to one-third of the scale used for the chart in Column 1.

178. VELOCITY AND ACCELERATION DIAGRAMS SHOWING CHARACTERISTIC ACTION OF CAMS HAVING DIFFERENT FORMS OF BASE CURVES. All of the diagrams in Column 3, Figs. 70 to 121, show the velocity given to the follower by the cam at every instant during the follower stroke. In each case the length of the diagram AC represents the time required by the cam to turn through 60° , the cam shaft being assumed to be turning with uniform angular velocity. The numbered scale on each diagram shows the relative velocity given by each cam at any phase of the stroke.

179. All of the diagrams given in Column 4 show the acceleration given to the follower by the different cams. These diagrams have a special interest when it is remembered that force = mass \times acceleration, and if the mass is the same in all cases the ordinates of the diagrams represent the forces necessary to move the follower at any instant. A diagram with a distinctively long ordinate indicates that the cam will "run hard" at the phase where the long ordinate occurs. The scale numbers shown on the diagrams are based on the uniform acceleration given by the parabola cam as shown in Fig. 93.

180. THE CHARACTERISTIC ACTIONS OF DIFFERENT CAMS built from the various base curves will be considered, in order, in the following paragraphs.

181. THE ALL-LOGARITHMIC CURVE, Fig. 70, gives the smallest possible cam for a given pressure angle. It differs from all other cam curves in that it gives the maximum pressure angle all the time that the follower is moving, whereas the others give a maximum pressure angle for an instant only. One of the disadvantages of the all-logarithmic cam is that it causes the follower to attain nearly its full velocity instantaneously, and causes it to come to rest in a similar manner, thus giving a shock at the beginning and end of the stroke. This gives excessively large acceleration and retardation at the ends of the stroke and causes the cam to "pound" or "run hard" at these phases of its action. Another disadvantage is that a roller cannot be used with it because the pitch surface has a sharp edge, or angle, on the working side as shown at C , Fig. 71. The rea-

COMPARISONS OF CAMS FOR DIFFERENT

COLUMN 1
CAM CHARTS AND BASE CURVES
FOR ONE-SIXTH OF CAM

COLUMN 2
RELATIVE SIZES OF CAMF.

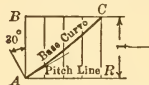

FIG. 70. ALL-LOGARITHMIC CURVE.

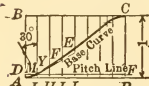

FIG. 74. LOGARITHMIC-COMBINATION CURVE.

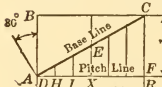

FIG. 78. STRAIGHT LINE

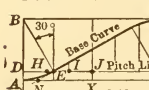

FIG. 82. STRAIGHT-LINE COMBINATION CURVE.

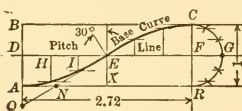

FIG. 86. CRANK CURVE

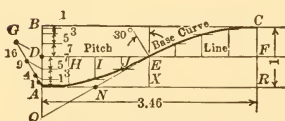

FIG. 90. PARABOLA

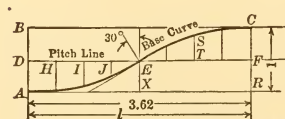

FIG. 94. TANGENTIAL BASE CURVE, CASE 1

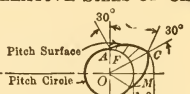

FIG. 71.

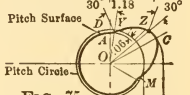

FIG. 75.

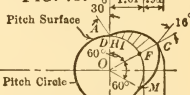

FIG. 79.

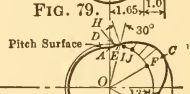

FIG. 83.

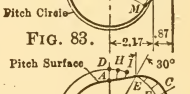

FIG. 87.



FIG. 88.

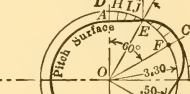

FIG. 91.

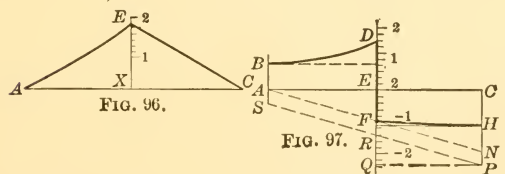
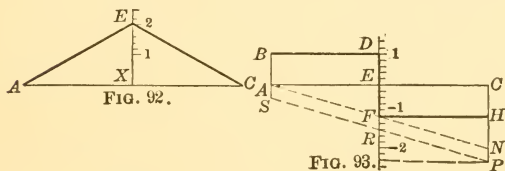
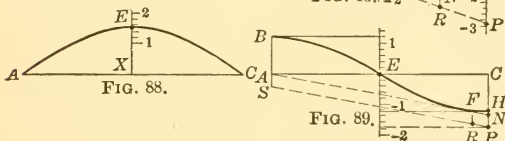
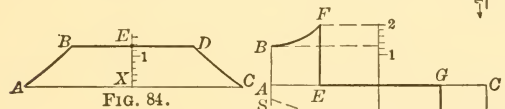
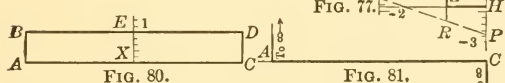
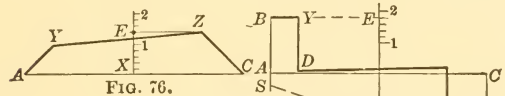
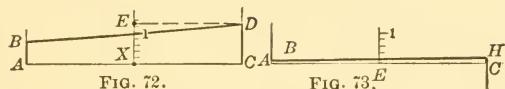

FIG. 95.

BASE CURVES, ALL HAVING SAME DATA

COLUMN 3
VELOCITY DIAGRAMS

COLUMN 4
ACCELERATION
DIAGRAMS



COMPARISONS OF CAMS FOR DIFFERENT

COLUMN 1
CAM CHARTS AND BASE CURVES
FOR ONE-SIXTH OF CAM

COLUMN 2
RELATIVE SIZES
OF CAMS

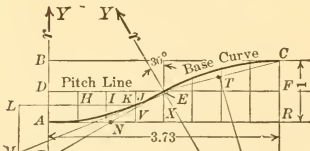

FIG. 98.—CIRCULAR CURVE, CASE 1

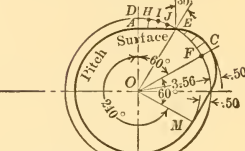

FIG. 99.

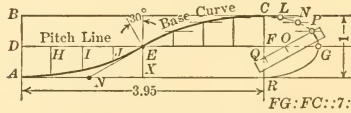

FIG. 102.—ELLIPTICAL CURVE



FIG. 103. Pitch Circle

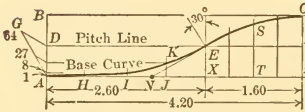

FIG. 106.—CUBE CURVE, CASE 1



FIG. 107.

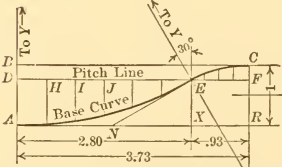

FIG. 110.—CIRCULAR CURVE, CASE 2

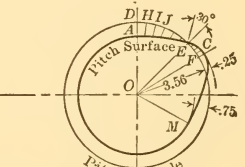

FIG. 111.

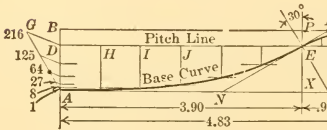

FIG. 114.—CUBE CURVE, CASE 2



FIG. 115. Pitch Circle

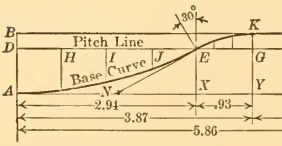

FIG. 118.—TANGENTIAL BASE CURVE,
CASE 2

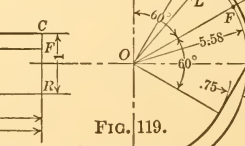

FIG. 119.

Pitch Circle

son why a roller cannot be used under these conditions is explained in paragraph 59, page 37. The construction of the all-logarithmic cam is explained in the following paragraphs.

182. PROBLEM 20. REQUIRED AN ALL-LOGARITHMIC CAM CAUSING :

- (a) The follower to rise 1 unit in 60° turn of the cam,
- (b) “ “ “ fall 1 “ “ 60° “ “ “ “
- (c) “ “ “ remain stationary for 240° turn of the cam,
- (d) A uniform pressure angle of 30° .

183. A BRIEF GENERAL ANALYSIS for the method of procedure in solving an all-logarithmic cam problem is:

(1) To construct a logarithmic spiral having a constant normal angle of 30° . The spiral is shown at BH , Fig. 122, and the constant

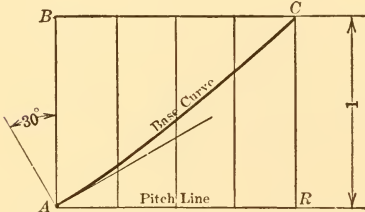

FIG. 70.—(Enlarged) ALL-LOGARITHMIC BASE CURVE

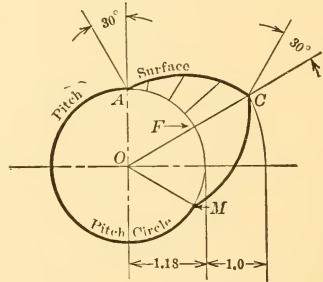

FIG. 71.—(Enlarged) ALL-LOGARITHMIC CAM

angle is noted at JDK , where DK is a radial line and DJ a line normal to the curve.

(2) To lay out the assigned working angle during which the follower motion takes place, on a piece of tracing cloth or tracing paper, as at t in Fig. 123.

(3) To mark on each leg of the angle a scale to measure the follower's motion, as at $O'M$ and $O'N$ in Fig. 123.

(4) To lay the tracing cloth represented by Fig. 123 over the logarithmic spiral with the apex O' of the angle always at the pole O of the spiral, and to rotate the tracing cloth until the two legs of the angle cut the spiral at such points that the difference in length of the two legs is equal to the assigned follower motion. This is illustrated in Fig. 122 where the shaded area represents the tracing-cloth with the assigned angle of 60° shown at b , while OC minus OA equals the assigned follower motion of 1 unit.

(5) To mark the included part of the logarithmic spiral AC and use it as the surface of the cam as shown at AC in Fig. 124.

184. THE DETAIL CONSTRUCTION necessary to lay out the all-logarithmic cam for Problem 20 is as follows: Construct a logarithmic spiral with a constant normal angle of 30° . This may be done mathematically by laying off computed values which method will be taken up first, or it may be done graphically as will be explained later.

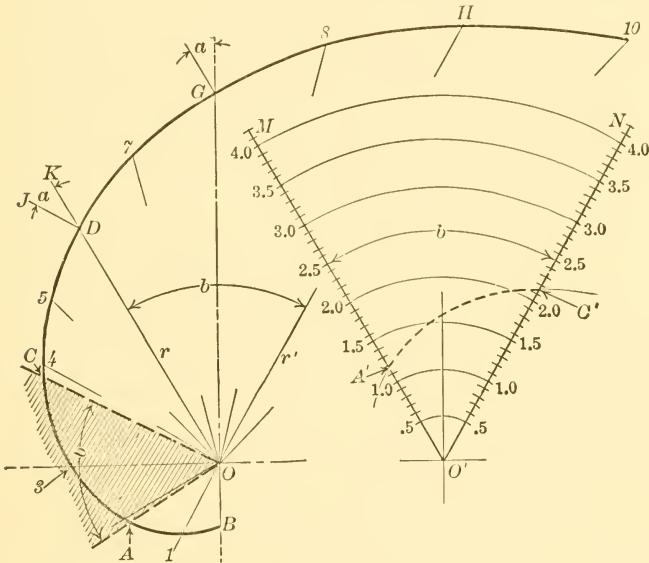

FIG. 122.—LOGARITHMIC CURVE GIVING CONSTANT PRESSURE ANGLE OF 30 DEGREES

FIG. 123.—ASSIGNED WORKING ANGLE, TO BE DRAWN ON TRACING CLOTH

In the mathematical method the first step is to solve the following equation:

$$\frac{r'}{r} = 10^{0.4343 \frac{\pi}{180} b \tan(90^\circ - a)}$$

where a is the assigned pressure angle and b is a unit angle taken at any value which may be conveniently used later in starting the drawing of the spiral. The values of r and r' are shown at OD and OH respectively in Fig. 122. The angles a and b are also shown. A convenient angle to assume for b , in general, is 60° and it is so taken in this problem. Then $\frac{r'}{r}$ equals the number whose logarithm is

$0.4343 \times \frac{3.14}{180} \times 60^\circ \times \tan (90^\circ - 30^\circ)$. Solving, the value of the logarithm is 0.2623 and the number corresponding to this is 1.83. Therefore,

$$\frac{r'}{r} = 1.83$$

and OH , Fig. 122, is made 1.83 times OD , the included angle being 60° in accordance with the above assumption for b . The length OD may be taken any length in starting the construction of the spiral. The two points of the spiral may now be laid down as at D and H with O as the pole.

185. INTERMEDIATE POINTS ON THE LOGARITHMIC SPIRAL as at G may be found by bisecting the angle DOH and making OG a mean proportional between OD and OH . Then

$$OD : OG : : OG : OH$$

If OD is taken as 3 units, then $OG = \sqrt{3 \times (1.83 \times 3)} = 4.06$. To find points on the spiral at closer intervals bisect angle DOG and find the mean proportion $O\gamma$ which is equal to $\sqrt{3 \times 4.06} = 3.52$. To find other points outside of a given angle, such as at 5 , lay off the angle $DO5$ equal to angle $DO\gamma$ and make $O5$ a fourth proportional to $O\gamma$ and OD as follows:

$$O5 : OD : : OD : O\gamma$$

Then
$$O5 = \frac{3^2}{3.52} = 2.58.$$

If points are desired still closer together, or if it is desired to extend the spiral in either direction, it may be done by the above-described processes, or, it may be done graphically as described in paragraph 187.

186. The next detail step in the solution of Problem 20 is to draw an angle $MO'N$, Fig. 123, on tracing cloth, equal to the assigned angle of 60° as given at (a) in the data, and lay off a scale on each leg of the angle as shown. Then lay Fig. 123 over Fig. 122, O' always at O , and rotate the tracing cloth until the spiral BH intercepts the lines $O'M$ and $O'N$ at such points that $O'C'$ minus $O'A'$ equals the assigned follower motion which is 1 unit as stated at (a) in Problem 20. This occurs when Fig. 123 is at the position

187. Intermediate points on the logarithmic spiral may be found graphically, instead of by computation as given in paragraph 185, as follows: From any point O of a straight line, Fig. 125, lay off OD and OH in opposite directions, OD and OH being the values obtained by computation in paragraph 184 and shown in Fig. 122. At O , Fig. 125, erect a perpendicular line. Find the midpoint O_1 on the line DH , and with this as a center for the compass draw the semicircle DGH . Then OG will be a mean proportional between OD and OH and may be laid out as the ordinate of the logarithmic spiral, as at OG , Fig. 122, where OG bisects the angle DOH .

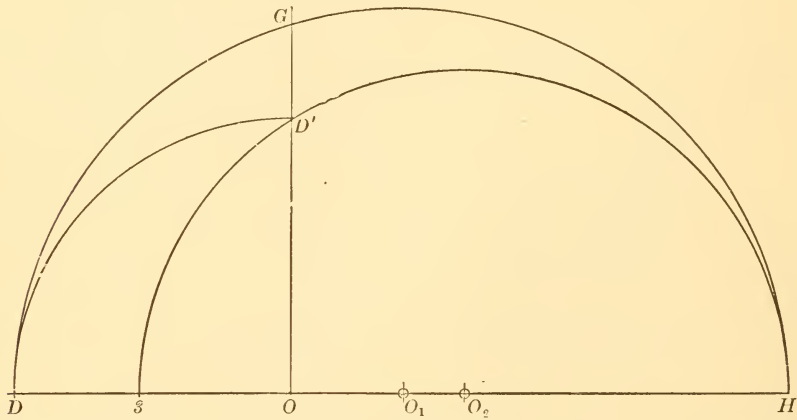

FIG. 125.—GRAPHICAL METHOD FOR FINDING INTERMEDIATE POINTS ON LOGARITHMIC CURVE

To find a fourth proportional graphically proceed as follows: Lay off the two known values, OD and OH , which are shown in Fig. 122, at right angles to each other as shown at OD' and OH in Fig. 125. Find the point O_2 on OH that is equidistant from D' and H , and with this as a center draw the semicircle $HD'S$, giving the length OS as the fourth proportional. This latter distance is laid off at OS in Fig. 122 where the angle $DO S$ is equal to angle DOH .

188. A GRAPHICAL METHOD FOR CONSTRUCTING A LOGARITHMIC SPIRAL WHICH HAS A GIVEN CONSTANT NORMAL ANGLE is illustrated in Fig. 126. This method, referred to in paragraph 184, is based on the following theoretical property of the logarithmic spiral, namely, that all pairs of radiants having a common difference embrace equal lengths of arcs on the spiral.

189. The principle stated in the previous paragraph may be graphically applied only approximately, but with all necessary precision, by first drawing the lines MP and PN , Fig. 126, making the desired angle with each other. This angle will be 30° if a spiral having a constant normal angle of 30° is required, 40° if a constant pressure angle of 40° is required, etc. From a point O , where the vertical intercept OD is equal to about the estimated short radius of the cam, draw a series of equidistant vertical lines as at B, C, E , etc. With BF as a radius and O as a center draw the short arc 1; with DF as a radius and D as a center draw arc 2. The intersection of arcs 1 and 2 will give the point H on the spiral. Again, with CG as a radius and

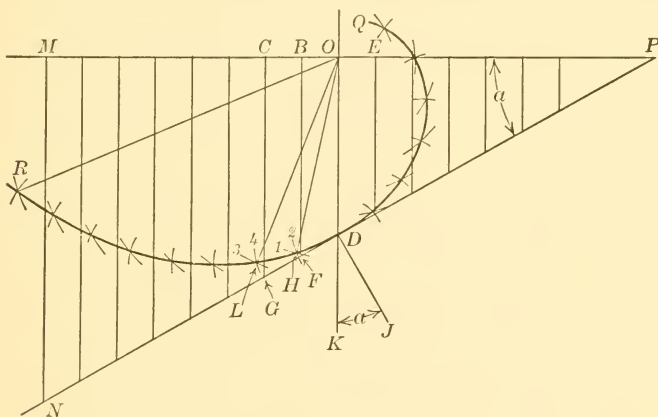

FIG. 126.—GRAPHICAL METHOD FOR CONSTRUCTING A LOGARITHMIC CURVE HAVING A GIVEN CONSTANT NORMAL ANGLE

O as a center draw arc 3; and with FG (equal DF) as a radius and H as a center draw arc 4. The intersection of arcs 3 and 4 will give a second point L on the logarithmic spiral. It will now be noted that the two pairs of radiants $HO - DO$ and $LO - HO$ have a common difference, and that the logarithmic arcs DH and HL are equal (approximately), which accords with the general principle laid down in the preceding paragraph.

190. To be exact, in the matter of the graphical construction of the logarithmic spiral, it must be noted that it is the chords from D to H and from H to L that are equal according to this method of construction and not the arcs as they should be theoretically; but where the vertical construction lines are taken close together and where the distance DF is, therefore, small, the error in the curve is negligible.

In the present case the ultimate distance OR when drawn with average care to a scale several times that shown in Fig. 126, varied from the computed value by less than .01 inch. The part of the curve from D to Q will depart from theoretical values faster than the part from D to R , due to the sharper curvature of DQ , but the effect of this may be overcome, if desired, by making the vertical construction lines to the right of OD closer than those to the left of OD .

191. THE ALL-LOGARITHMIC CAM MAY BE CONSTRUCTED BY A PURELY GRAPHICAL METHOD, and without any mathematical computation whatever. In Problem 20, for example, it would only be necessary to follow the directions in paragraphs 188 and 189, making the angle a of Fig. 126 equal to 30° which is the assigned pressure angle in the problem. This would give the proper logarithmic curve identical with the one in Fig. 122. From this point on, the directions given in paragraph 186 apply. If a pressure angle of any other size were desired, say 45° , the angle MPN Fig. 126, would be made 45° .

192. EXERCISE PROBLEM 20a. REQUIRED AN ALL-LOGARITHMIC CAM which will cause a follower to:

- (a) Rise two units in 45° turn of the cam.
- (b) Remain stationary for 135° " " " "
- (c) Fall two units in 45° " " " "
- (d) Remain stationary for 135° " " " "
- (e) The constant pressure angle to be 30° .

193. A LOGARITHMIC-COMBINATION CAM may be used to overcome

the disadvantages (paragraph 181) of the all-logarithmic cam and at the same time to sacrifice very little in the matter of increased size. This is accomplished by substituting rounded surfaces for the angular surfaces formed by the all-logarithmic curve. When the rounded surface thus substituted is derived from parabolic base arcs the best results are obtained. A cam in which this has been done is shown in Fig. 75, where the curves AY and ZC are arcs of a parabola base and the center portion YZ is an

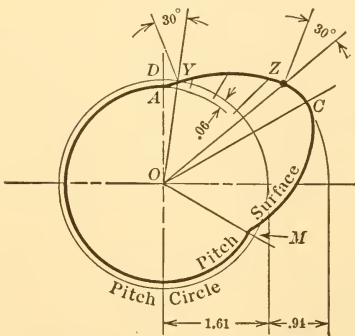

FIG. 75.—(Enlarged) LOGARITHMIC-COMBINATION CAM

ZC are arcs of a parabola base and the center portion YZ is an

arc of a logarithmic curve. To illustrate an actual case, a problem having the same general data as Problem 20 will be discussed in the following paragraphs.

194. PROBLEM 21. REQUIRED A LOGARITHMIC-COMBINATION CAM causing the follower to:

- (a) Rise 1 unit in 60° turn of the cam.
- (b) Fall 1 " " " " " " " "
- (c) Remain stationary for 240° turn of the cam.
- (d) The maximum pressure angle to be 30° , and the easing-off base curves to be parabolic arcs.

195. A BRIEF GENERAL ANALYSIS of the method of procedure in solving problems of this kind is:

- (1) To draw a general logarithmic curve on rectangular coordinates, the longest and shortest ordinates of which will correspond to the estimated longest and shortest radii of the cam, or the longest and shortest radii of a series of cams if a series should happen to be under design.
- (2) To compute the length of rectangular cam chart, as directed in paragraph 198, and to draw the rectangle on tracing cloth or tracing paper.
- (3) To construct parabolic arcs within the rectangular cam chart as directed in paragraph 199.
- (4) To place the cam chart as now drawn on the tracing cloth, over the logarithmic curve, so that the logarithmic curve will be tangent to the two parabolic arcs while the bottom line of the chart is parallel to the abscissa of the logarithmic curve. The distance between the bottom of the chart and the abscissa will be the shortest radius of the cam.

196. The first step in the detail of the solution of Problem 21 is to construct a logarithmic curve on rectangular coordinates as in Fig. 127. This curve is a perfectly general one and if it is drawn with a wide enough range of ordinates will do for all possible logarithmic-combination cams, independently of all specific data. To construct the logarithmic curve draw a horizontal abscissa line OO' , Fig. 127, and erect a series of ordinates one unit apart as on both sides of r , making their length a geometrical progression. To do this, make the first ordinate drawn, say OL , equal to 1 unit and all succeeding ordinates such as r_1, r_2 longer than the preceding ordinate by using any common multiplier throughout; also, all preceding

ordinates such as r' , r'' , if they are necessary, shorter by the inverse of the same ratio. For example, if OL equals 1 and if the common multiplier is taken as 1.25 (it may be any convenient number), then $r_1 = 1 \times 1.25 = 1.25$, $r_2 = 1.25 \times 1.25 = 1.5625$, $r_3 = 1.5625 \times 1.25 = 1.953$, etc.; also $r' = 1 \times \frac{1}{1.25} = .8$, $r'' = .8 \times \frac{1}{1.25} = .64$ etc. The lengths should be accurately computed up to the length of the maximum radius of the largest cam that is likely to be used and the curve LG carefully drawn.

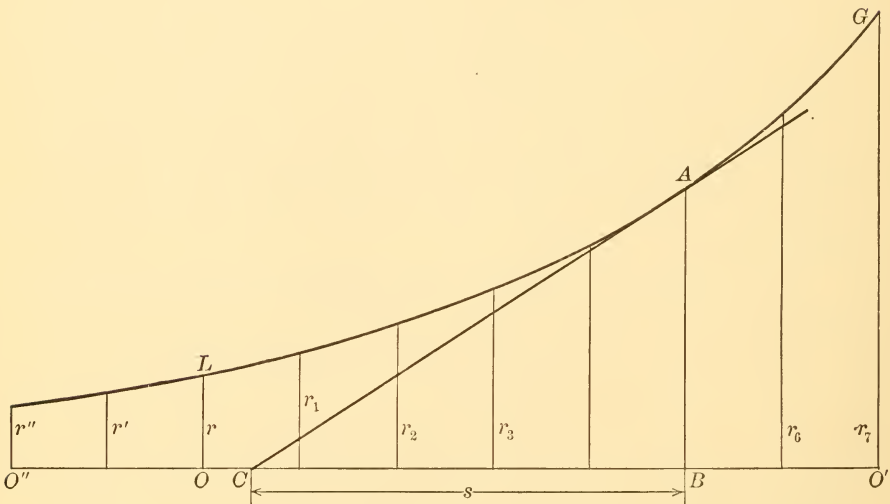

FIG. 127.—GENERAL LOGARITHMIC CURVE SHOWING SUBTANGENT, USEFUL IN SOLVING A WIDE RANGE OF LOGARITHMIC CAM PROBLEMS

197. The length of the sub-tangent, s , in Fig. 127, is next found by the formula, $s = \frac{.434}{\log. m}$, where m is the common multiplier used in laying out the logarithmic curve LG . Since the value of m is 1.25 in this problem, $s = \frac{.434}{.097} = 4.48$. This value of the sub-tangent may also be found graphically by drawing tangents to the logarithmic curve, by eye, at several points and taking an average of the sub-tangents thus found. This average value will probably be close enough for most practical work. The tangent line at A is shown at AC , Fig. 127. The length of the sub-tangent, BC , will be the same for each tangent line if it is accurately drawn.

198. A special form of rectangular diagram, Fig. 128, depending on the data is now constructed, its length being:

$$l = \frac{b \pi s \tan a}{180}$$

- where l = length of diagram,
- b = assigned angle of action,
- s = length of sub-tangent of the logarithmic curve as found in the preceding paragraph,
- a = assigned pressure angle.

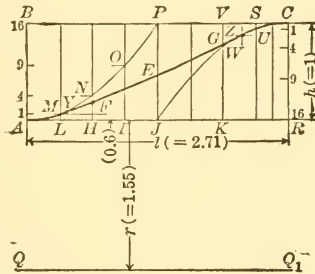

FIG. 128.—RECTANGULAR CHART USED IN DESIGN OF LOGARITHMIC-COMBINATION CAM

Taking the figures from the data for this problem, and the value of s as found and substituting in the above formula,

$$l = \frac{60 \times 3.14 \times 4.48 \times .577}{180} = 2.71.$$

The height of the diagram is the continuous motion of the follower in one direction and is 1 unit in this problem as indicated at RC , Fig. 128. Draw the rectangle, as shown at ARC at or near the top of a piece of tracing cloth or tracing paper, leaving a length under it equal at least to what the short radius of the cam is estimated to be.

199. PARABOLIC EASING-OFF ARCS FOR LOGARITHMIC-COMBINATION CAM. The length of the rectangular diagram is now divided into at least 8 equal parts which are sufficient for practice problems, but in practical applications at least 16 divisions should be taken. A diagram divided into 8 parts is shown in Fig. 128. Construct a parabola with vertex at A and passing through the midpoint of the diagram as at P . This is done as explained in detail in paragraph 35

and, briefly as follows: Divide AB into a series of equal parts, the total number of parts being equal to the square of the number of construction spaces between A and J . In this problem there are four construction spaces and so AB is divided into 16 equal parts and the 1st, 4th and 9th division points are projected horizontally to M , N and O which are points on the parabola. Construct the similar parabolic arc CJ in the same way.

Lay the rectangular diagram constructed as above on tracing cloth over Fig. 127 and manipulate it, always with the line AR , Fig. 128, parallel with the line OO' , Fig. 127, until the logarithmic curve LG , showing through the tracing cloth, is tangent to the two-parabolic arcs. This occurs, in this problem, when AR is 1.55 units above OO' , and 1.55, therefore, is the shortest radius of the pitch surface of the cam. For precision work later on, mark the points Y and Z , Fig. 128, where the logarithmic arc comes tangent to the parabolic arcs.

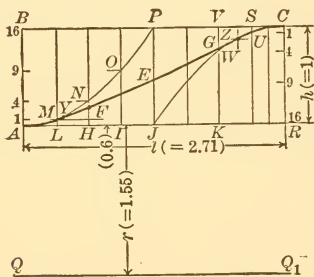

FIG. 128.—(Duplicate) RECTANGULAR CHART USED IN DESIGN OF LOGARITHMIC-COMBINATION CAM

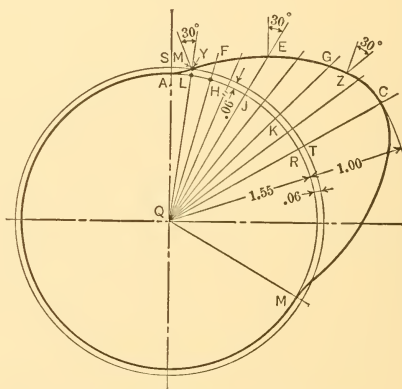

FIG. 129.—PROBLEM 21. LOGARITHMIC-COMBINATION CAM WITH PARABOLIC ARCS AT ENDS

200. The cam may now be constructed, drawing first the circle, Fig. 129, having a radius QA of 1.55 units. Lay out the angle AQC equal to the assigned 60° and divide it into equal spaces by as many radial lines as there are ordinates in Fig. 128. Transfer the ordinates LM , HF , etc., from Fig. 128 to Fig. 129 and draw the pitch surface of the cam through the points A , M , F , etc. The working surface would be a parallel curve distant from the pitch surface by the radius of the follower roller. With this cam there would be uniform acceleration of the follower from A to Y where the pressure angle reaches

30°. This angle remains constant until Z comes into action, when the follower is uniformly retarded to zero at C .

201. If it is desired to know the pitch circle of the cam it may be found by noting, in Fig. 128, where the logarithmic arc comes tangent to the starting parabolic arc. This is at Y and in this problem it is .06 unit from the bottom of the diagram. This distance is laid off at AS in Fig. 129 to obtain the pitch circle ST . If it is desired further, to obtain the cam chart which is necessary to draw the velocity and acceleration diagrams, it may be found as represented in Fig. 74 where the length DF' is equal to length of the arc ST in Fig. 129 when both are drawn to the same scale. DF' is the pitch line of the chart, and AR is .06 unit below it, this value being taken from Fig. 128. The length of the ordinates, LM, HF , etc., in Fig. 74

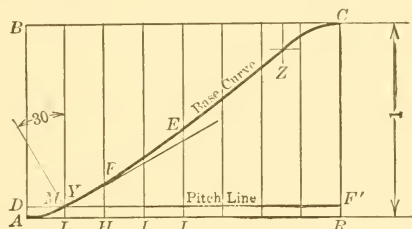

FIG. 74.—(Enlarged) LOGARITHMIC-COMBINATION BASE CURVE

are equal to those in Fig. 128 when both figures are drawn to the same scale. It will be noted that no factor is given in connection with the cam chart for the logarithmic cam as it is for other cams. There is no constant factor; it varies with each problem.

202. The rates of acceleration and retardation that will be given by the cam at the ends of the stroke are arbitrarily determined in Fig. 128 by causing the parabolic arcs to pass through P and J . With the parabolic arcs so taken good average results will be obtained, as compared with other small cams. If different accelerations and retardations are desired for the follower the point P may be located further up, or further down, and the cam will be either smaller or larger.

203. EXERCISE PROBLEM 21a. REQUIRED A LOGARITHMIC-COMBINATION CAM with parabolic easing-off arcs which will cause a follower:

- (a) To rise 3 units in 90° turn of the cam.
- (b) To remain stationary for 180° turn of the cam.

- (c) To fall 3 units in 90° turn of the cam.
- (d) The maximum pressure angle to be 35°.

204. THE CHARACTERISTICS OF A CAM HAVING A STRAIGHT BASE LINE have already been considered in the early part of this book, in paragraph 32. A sharp or V-edge sliding follower is the only kind that can be used with the straight base line for true results; a roller cannot be used for reasons explained in paragraph 59. The form of the pitch surface of the cam that is derived from the straight base line is the Archimedean spiral. The straight base line gives the smallest simple cam for a given maximum pressure angle. Its method

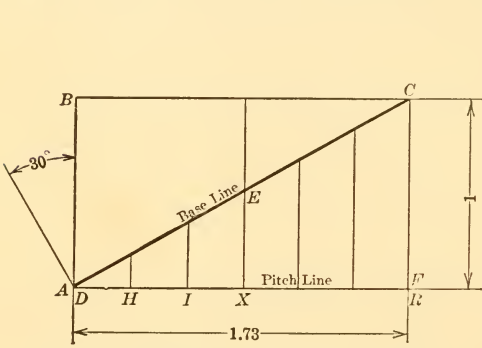

FIG. 78.—(Enlarged) STRAIGHT BASE LINE

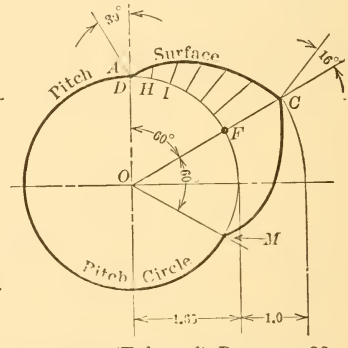

FIG. 79.—(Enlarged) PROBLEM 22. STRAIGHT BASE LINE CAM

of construction is illustrated in Figs. 78 and 79 for a problem of the following data:

205. PROBLEM 22. REQUIRED A CAM WITH A STRAIGHT-LINE BASE in which the follower:

- (a) Rises 1 unit in 60° turn of the cam.
- (b) Falls 1 “ “ 60° “ “ “ “
- (c) Remains stationary for 240° turn of the cam.
- (d) The maximum pressure angle to be 30°.

206. In accordance with formula (1), paragraph 29, the radius of the pitch circle will be $57.3 \frac{1 \times 1.73}{60} = 1.65$ which is drawn at OD in Fig. 79. The given angle of 60° for the rise is laid off at DOC and divided into any convenient number of construction parts, six being shown by the radial extension lines in the Figure. The first line is $\frac{1}{6}$ of FC , the second $\frac{2}{6}$ of FC , etc. Inasmuch as no roller

can be used with this cam the pitch and working surfaces coincide, and a V-edge follower must be used for true results. The maximum pressure angle occurs at the start and grows smaller towards the end of the stroke; in this problem it diminishes to 16° as indicated in the Figure.

207. EXERCISE PROBLEM 22a. REQUIRED A CAM WITH A STRAIGHT-LINE BASE in which the follower:

- (a) Rises 3 units in 120° turn of the cam.
- (b) Falls 3 " " 120° " " " "
- (c) Remains stationary for 120° turn of the cam.
- (d) The maximum pressure angle to be 30° .

208. THE STRAIGHT-LINE COMBINATION BASE CURVE, Fig. 82, gives increasing velocity and acceleration at the beginning of the

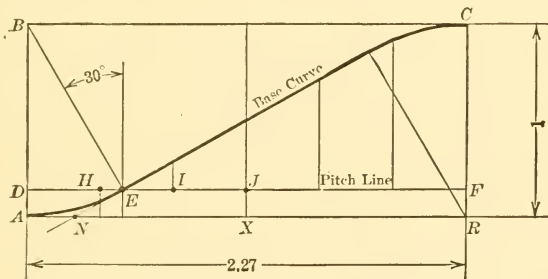

FIG. 82 (Enlarged) STRAIGHT-LINE COMBINATION BASE CURVE

stroke, uniform velocity and zero acceleration during a large middle portion of the stroke, and decreasing velocity and retardation at the end. The length of the period for uniform velocity and the amounts of acceleration and retardation depend entirely on the length of the easing-off radius. This may be taken at any value. The acceleration diagram in Fig. 85 is based on a radius equal to the follower motion as shown at BA , Fig. 82. The shorter this radius is taken, the nearer the straight-line combination curve approaches the cam having a straight base line, Fig. 78, and the action at the beginning and at the end of the stroke becomes more violent. The longer the easing off radius is taken, the nearer the combination curve approaches the circular base

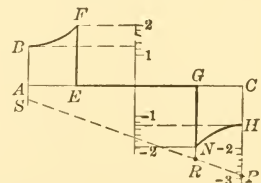

FIG. 85.—(Duplicate) ACCELERATION DIAGRAM FOR STRAIGHT-LINE-COMBINATION CAM

Fig. 87, outward radially by the amount d given in the following formula:

$$d = \frac{.5 h}{\sqrt{1 + \frac{\pi^2}{b^2} \cot^2 a}}$$

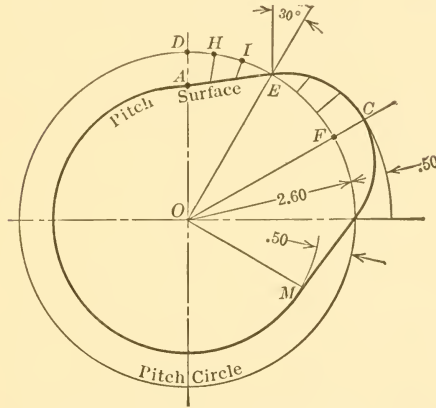

FIG. 87.—(Enlarged) CRANK CURVE CAM

where d = distance the points on the pitch surface, as obtained in the ordinary way, would have to be moved out radially to obtain exact size of crank curve cam for a given maximum pressure angle.

h = total rise of follower.

b = angle turned by cam during the follower's total rise, in radians. If b is taken in degrees the number 180 must be used in place of π .

a = pressure angle in degrees.

The maximum pressure angle of 30° would then occur where the enlarged pitch surface crosses the pitch circle which would be slightly to the left of E , Fig. 87. The cam would be .09 larger in maximum radius, or 3.19 units from O to C instead of 3.10 as shown and as used in practice.

212. Another way of obtaining exact results with the crank curve would be to compute the length of the chart from the following formula:

$$l = .5 b h \sqrt{1 + \frac{\pi^2}{b^2} \cot^2 a}$$

which will be described later, a curve is used in which the ordinates of the curve vary as the cube of the time.

215. THE PARABOLA BASE CURVE will also operate a follower with the least amount of effort of any of the base curves, due to the fact that the acceleration is constant. Since the mass is also constant in cases under comparison, the force required to move the follower will be constant and may be represented by 1.0 as shown in Fig. 93 in comparison with a maximum of 1.8 for the logarithmic-combination cam, Fig. 77; 2.0 for the straight-line combination curve, Fig. 85; 1.2 for the crank curve, Fig. 89; 1.6 for the tangential curve, Case I, Fig. 97; 1.5 for the circular curve, Case I, Fig. 101; and 1.7 for the elliptical curve, Fig. 105. These figures are for symmetrical chart curves. Among the unsymmetrical chart curves shown in Figs. 110, 114, etc., much larger direct forces even may be required to operate the cam as illustrated by the relative maximum values of 2.9 for the circular curve, Case II, Fig. 113; 4.8 for the cube curve, Fig. 117; and 6.4 for the tangential cam, Case II, Fig. 121.

216. COMPARISON OF PARABOLIC AND CRANK BASE CURVES. While the parabola base curve combines the two highest theoretical considerations, namely smoothest possible motion and least power for operation, it has not become so widely used as the crank curve. This may be due to the experience of builders of cams who have found that the crank curve permits of a smaller cam for a given pressure angle than does the parabola; or for the same size cams the pressure angle is the smaller for the crank curve and, therefore, does not "stick" or "run hard" so much as the parabola cam of equal size. Figures on which the above statements are based may be seen in Fig. 87 where it is shown that a maximum radius of 3.1 inches is required for a lift of 1 inch in 60° with a maximum pressure angle of 30° when the crank curve is used; while in Fig. 91 a parabola cam is shown to require a maximum radius of 3.8 inches for the same data. The crank curve has obtained some undue comparative credit over the "parabola" curve on account of the fact that the "parabola" was constructed with spaces in some other ratio than 1, 3, 5, etc. While, for example, a true parabola may be constructed with spaces of 1, 2, 3, instead of 1, 3, 5, as used in paragraph 35,

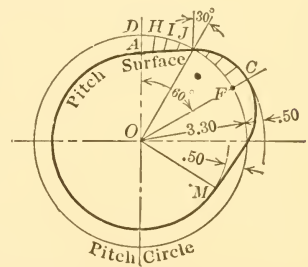

FIG. 91.—(Enlarged) PARABOLA CAM

of the crank curve. It may be observed, however, that the parabola is really no more difficult to draw than the crank curve, and when it is fully understood it is quite certain that the parabola cam will come into a more general use in all cases except where space is extremely limited, or where special considerations of the follower motion as to spring or gravity action or as to low striking or seating velocity, etc., become especially desirable. The subjects of spring action and low striking velocities will be treated in paragraph 273, *et seq.*

218. TANGENTIAL BASE CURVE. This base curve differs from the others in that it cannot be readily used to construct the cam. The cam itself is drawn first by using straight lines as the side boundaries of the cam lobe, the straight lines being rounded off at the ends by arcs of circles or other smooth curves as shown in Fig. 95. At the inner ends, the straight lines are tangent to a circle which has the center of rotation of the cam as its center. The base curve for this cam is useful only where it is desired to find graphically the velocity and acceleration diagrams, and when it is so used, it must be derived from the cam drawing as explained in paragraph 225. The tangential cam is perhaps the easiest of all cams to draw when one is not particular about the maximum pressure angle, but it is apt to give the highest velocities and the greatest accelerations of all the cams when it is laid out "by eye" by an inexperienced person. To keep the tangential cam under control when being designed, requires either a preliminary graphical construction, or a series of computations by means of formulas which will give results that may be laid out directly.

219. PROBLEM 23. TANGENTIAL CAM, CASE I. Required a tangential cam in which the follower:

- (a) Rises 1 unit in 60° turn of the cam.
- (b) Falls 1 " " 60° " " " "
- (c) Remains at rest for 240° turn of the cam.
- (d) The maximum pressure angle to be 30° and the end of the lobe to be rounded off by a circular arc.

Find: The shortest radius of pitch surface of cam, the length of the straight-line portion of the cam lobe, the radius of the rounding off curve at the end, and the largest size roller that may be used.

220. THE GRAPHICAL METHOD OF CONSTRUCTION FOR THE TANGENTIAL CAM is as follows: In a preliminary and separate drawing, construct an angle $A O E$, Fig. 130, equal to the given pressure angle;

draw a line $A E$ at right angles to $O A$ at any distance out, and continue $A E$ until it intersects $O E$; draw an angle $A O C$ equal to the assigned angle of action; drop a vertical line from E to $O C$; draw the arc $E C$ with L as a center; draw the arc $C G$ with O as a center, and measure the distances $G A$ and $A O$. Then $G A : h : : A O : s$, where h is the assigned motion of the follower and s is the correct radius at which to draw the line $A E$ in the direct drawing of the cam.

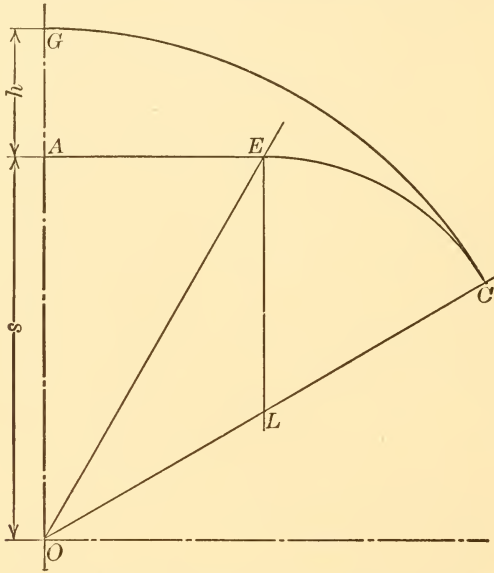

FIG. 130.—TANGENTIAL CAM, PRELIMINARY SKETCH IN GRAPHICAL METHOD OF CONSTRUCTION FOR DEFINITELY ASSIGNED DATA

In the present illustration $G A$, Fig. 130, is 1.33 units and $A O$ is 4 units. Therefore, in the direct drawing of the cam, Fig. 95,

$$s = \frac{h \times A O}{G A} = \frac{1 \times 4}{1.33} = 3.00,$$

and this value is laid off at $O A$ Fig. 95. The pitch surface of the cam $A E C$ is then drawn by repeating the operations in precisely the same order as in the preliminary drawing described above. The maximum pressure angle will be 30° at E where the circular easing-off arc is tangent to the straight line. The maximum radius of the roller would be $E L$, but as this would leave a sharp edge on the working surface of the cam, a value of $\frac{3}{4} E L$ is taken as the radius, thus giving $W N P$ as the working surface of the cam.

221. ANALYTICAL METHOD OF CONSTRUCTION OF THE TANGENTIAL CAM. A direct drawing of the tangential cam may be made from value obtained from a series of formulas having the following notation, in which all linear dimensions are in inches and all angular

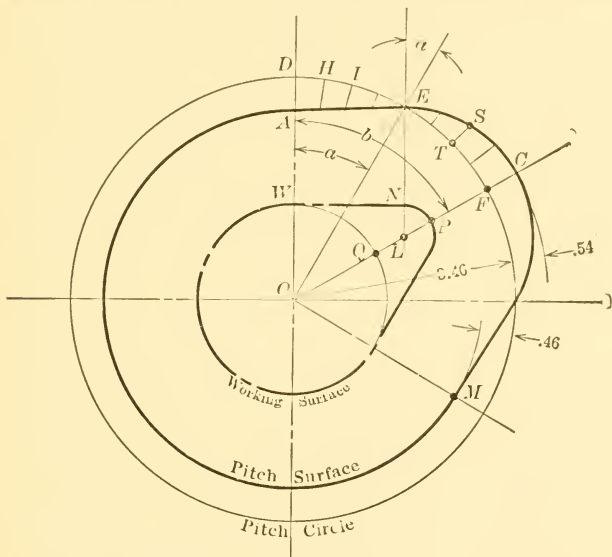

FIG. 95.—(Enlarged) PROBLEM 23. TANGENTIAL BASE CURVE CAM, CASE 1

dimensions in degrees unless otherwise specified. All symbols are illustrated in Fig. 131 which is for a general case:

h = total motion of follower.

x = fraction of follower's motion while rolling on the straight surface of the cam, or, fraction of stroke during which acceleration takes place.

a = maximum pressure angle.

b = time allotted by the data to the follower motion, measured in angular motion of the cam in degrees.

s = radius of pitch surface to which the straight pitch line is drawn tangent.

t = length of straight edge of cam on both pitch and working surface.

p = radius of pitch circle.

d = largest radius of pitch surface of cam.

c = angle turned through by the cam when the full motion of the follower is reached. c will equal b when the straight part of the cam is not assigned in the data.

e = radius of circular arc for rounding-off outer corner of pitch cam.

r = radius of roller.

w = radius of working surface to which the straight working line of the cam is drawn tangent.

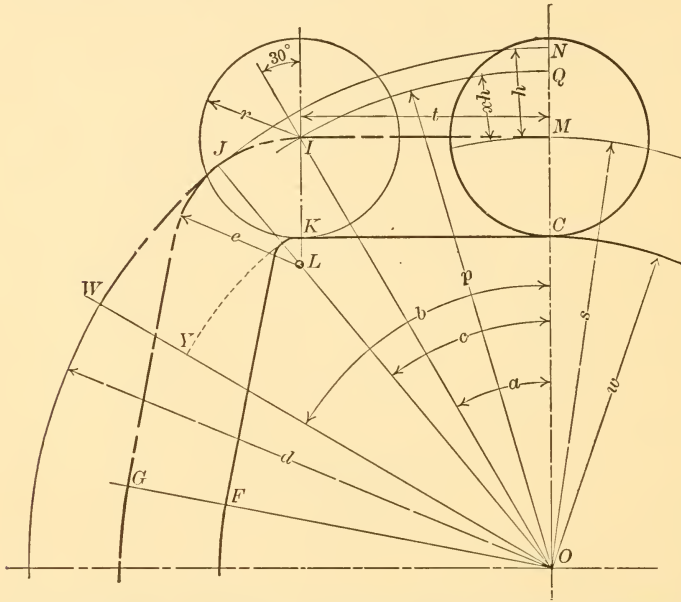

FIG. 131.—TANGENTIAL CAM, SHOWING TERMS USED IN THE DIRECT CONSTRUCTION BY THE ANALYTICAL METHOD

222. When the length of the straight part of the cam is not assigned in the data, c and b will be equal. When the length of the straight part is assigned c will figure out differently from b ; if it comes less the problem is possible with the assigned data; if more, the length of the straight part must be reduced.

The general formulas are:

$$s = \frac{xh}{\sec a - 1} \dots (1) \quad t = s \tan a \dots (2)$$

$$p = \frac{t}{\sin a} \dots (3) \quad d = s + h \dots (4)$$

$$\cot c = \frac{1}{2} \left(\frac{t}{h} - \frac{h}{t} \right) \dots (5) \quad e = d - \frac{t}{\sin c} \dots (6)$$

$$r \leq e \dots (7) \quad w = s - r \dots (8)$$

223. With the data of the present problem, equation (5) must be solved first, for it is the only one in which all the terms but one are known. This formula is solved for t . With t known, formula (2) may be solved for s , then formula (1) for x , and so on in order with equations (3), (4), (6), (7), and (8). These formulas give the following values in the present problem:

| | | | |
|------------|---------|--------------|------------|
| $t = 1.73$ | $s = 3$ | $x = .46$ | $p = 3.46$ |
| $d = 4$ | $e = 2$ | $r \leq 1.5$ | $w = 1.5$ |

224. With the above values, the cam in Fig. 95 is laid out in the following manner: Lay off given angle of 60° at $D O C$, draw circle

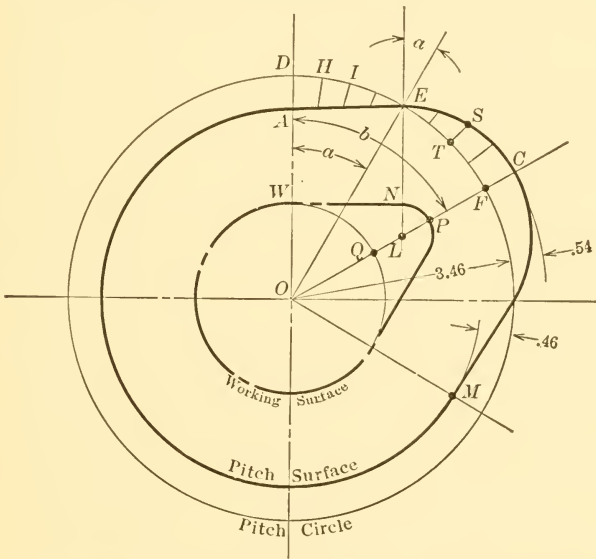

FIG. 95.—(Duplicate) PROBLEM 23. TANGENTIAL BASE CURVE CAM, CASE 1

having radius $O A$ equal to s , draw straight part of cam $A E$ equal to t , draw circular arc $E C$ with center on $O C$ and with radius of $L C$ equal to e , call $r = .75e$ and make $A W$ equal to it. Then $W N P$ is the working surface of the cam where $A W$ is the radius of the roller. The length $W N$ of the straight part of the working surface is the same as the length of the straight part of the pitch surface, and the circular arc $N P$ of the working surface has the same center as the arc $E C$ of the pitch surface. The values d and w are automatically included in the process of the above described layout.

gives variable velocity and acceleration to the follower the first half of the follower stroke, and also variable velocity and retardation during the last half, as shown in Figs. 100 and 101. It will be noted

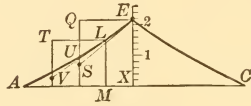

FIG. 100

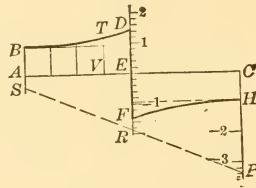

FIG. 101

FIG. 100.—(Duplicate) VELOCITY DIAGRAM FOR CIRCULAR BASE CURVE CAM
 FIG. 101.—(Duplicate) ACCELERATION DIAGRAM FOR CIRCULAR BASE CURVE CAM

that the circular curve, and the elliptical curve shown in Fig. 102, give nearly the same sized cams and that the velocity and acceleration diagrams for each are quite similar. With the circular base curve, the radial distances on the cam at *D, H, I, J*, Fig. 99, cannot be found

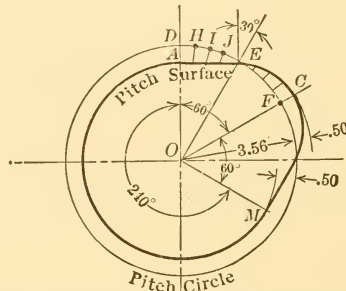

FIG. 99.—(Enlarged) PROBLEM 24. CIRCULAR BASE CURVE CAM, CASE 1

directly except by means of the chart or by computation. For graphical construction it is necessary to draw the chart, Fig. 98, first and it is then a simple matter to transfer the ordinates at *H, I, J*, to Fig. 99. The length of the chart for a maximum pressure angle of 30° is 3.73 times the motion of the follower.

230. The length of radius for the equal arcs in the circular base curve is 3.73 times the follower motion for a 30° maximum pressure angle. To find the length of radius for any other maximum pressure angle, use the formula:

$$r = \frac{h}{2(1 - \cos a)}$$

where r = the desired radius,

a = the desired maximum pressure angle,

and h = the given follower motion.

TABLE FOR CIRCULAR BASE CURVE

| For Maximum Pressure Angle of | Radius of Arc is |
|-------------------------------|------------------|
| 20° | 8.29 h |
| 30° | 3.73 h |
| 40° | 2.14 h |
| 50° | 1.40 h |
| 60° | 1.00 h |

231. PROBLEM 24. REQUIRED A CIRCULAR BASE CURVE CAM that will cause the follower to:

- (a) Rise 1 unit in 60° turn of cam.
- (b) Fall 1 “ “ 60° “ “ “
- (c) Remain stationary for 240° “ “ “
- (d) With a maximum pressure angle of 30°.

232. The general description of the circular base curve given in the two preceding paragraphs will doubtless give all the necessary information for the solution of this problem so that only a brief order of procedure will be given here. The total length of chart is

$$1 \times 3.73 \times \frac{360}{60} = 22.38.$$

One-sixth of this length is shown in Fig. 98. The radius of the circular arc $A E$, which is the same as $E C$, is

$$r = \frac{1}{2(1 - \cos 30^\circ)} = \frac{1}{2(1 - .866)} = 3.73.$$

Draw eight equally spaced ordinates as at H, I, J , etc., Fig. 98. The radius of the pitch circle of the cam is,

$$\frac{22.38}{2 \times 3.14} = 3.56,$$

In Fig. 98 the angles CST and EST are each equal to one-half the angle CSE which is the pressure angle and is designated by a in the following formulas. The triangles CEF and CST are similar in all cases. Therefore, a may be found by the following formula:

$$\tan \frac{1}{2} a = \frac{CF}{EF}$$

With a known, the radius of the arc EC may also be found as follows:

$$ES = \frac{EF}{\sin a} = CS.$$

235. EXERCISE PROBLEM 24a. Required a circular base curve cam which will cause the follower to:

- (a) Move out 3 units in 90° turn of the cam.
- (b) Remain stationary for 195° " " " "
- (c) Move in 3 units in 75° " " " "
- (d) With a maximum pressure angle of 40° .

236. ELLIPTICAL BASE CURVE. The elliptical base curve gives variable velocity and variable acceleration to the follower. By using different ratios for the horizontal and vertical axes of the ellipse on which the curve is based, the velocity of the follower may be made to increase rapidly or slowly at the start, and the cam may be made small or large and still not exceed a given maximum pressure angle.

237. ELLIPTICAL BASE CURVE, RATIO 7 TO 4. As stated in the preceding paragraph the elliptical cam may be based on ellipses having various proportions between their major and minor axes. When the proportions are as 7 : 4, as in Fig. 102 where $FG = 7$ and $FC = 4$, the length of the chart will be 3.95 times the travel of the follower for a maximum pressure angle of 30° . The cam will be larger, but the velocity of the follower will be less at starting and stopping and greater at midstroke than for any of the cams described thus far. If a still lower starting and stopping velocity is desired with an elliptical cam, it may be obtained by making the ratio of horizontal to vertical axes on the chart as 8 : 4, 9 : 4, or greater, instead of 7 : 4 as here used. The drawbacks to increasing the ratios above 7 : 4 are increased size of cam and high velocity at midstroke for a given pressure angle.

238. ELLIPTICAL BASE CURVE, RATIO 2 to 4. The cam produced from the elliptical base curve is shown, in the preceding paragraph, to give a certain characteristic action to the follower when the ratio

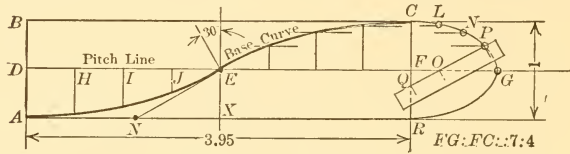

FIG. 102.—(Enlarged) ELLIPTICAL BASE CURVE

of the horizontal axis to the vertical axis is 7 to 4. When the ratio is 2 to 4, a totally different characteristic follower action is obtained as may be determined by a process of construction similar to that shown in Figs. 102 and 103.

The cam itself, with a ratio of 2 to 4, will be much smaller for a given pressure angle, as may be seen by comparing the abscissæ of curves 5 and 11 in Fig. 132. Where it is desired to use a very small cam for a given pressure angle, the 2 : 4 elliptical curve will have an advantage over the ordinary straight-line combination curve above 27° as may be noted from an inspection of curves 5 and 6, Fig. 132; but it is at a disadvantage compared with the logarithmic-combination cam at all pressures angles as is shown by a comparison of curves 2 and 5.

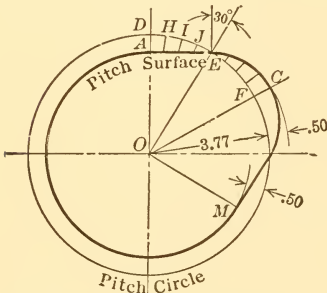

FIG. 103.—(Enlarged) ELLIPTICAL BASE CURVE CAM

239. ELLIPTICAL BASE CURVE MAY BE MADE EQUIVALENT TO NEARLY ALL OTHER BASE CURVES. Since the elliptical base curve may be constructed with any ratio of horizontal to vertical axes, it has a range of usefulness over the entire field covered by all the other base curves except the logarithmic curve. When the horizontal axis of the ellipse is zero, the elliptical base curve coincides exactly with the straight-line base. As the horizontal axis increases in length, the vertical axis remaining constant, the elliptical base curve crosses the straight-line combination curve. When the horizontal axis of the ellipse equals the vertical axis, the elliptical base curve is identical with the crank curve. As the horizontal axis continues to increase, the elliptical curve approximates very closely indeed to the parabola

when the ratio of horizontal to vertical axes is as 11 to 8. A further general characteristic of the elliptical curve is that the starting and stopping velocities grow smaller, and also the accelerations or starting and stopping forces grow smaller as the horizontal axis of the ellipse grows larger.

240. CUBE BASE CURVE, SYMMETRICALLY APPLIED. The cube base curve, Fig. 106, is similar in method of construction to the

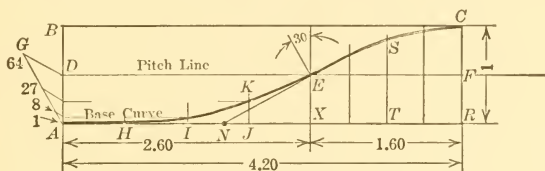

FIG. 106.—(Enlarged) CUBE BASE CURVE, CASE 1

parabola base curve, the only difference being that the cubes of the numbers 1, 2, 3, etc., instead of the squares, are used as ordinates of the curve. The cube curve gives extremely low and slowly increasing motion to the follower at the start as may be noted by an inspection of the velocity curve *A E*, Fig. 108, which shows the distinguishing characteristic that the velocity curve is tangent to the base line. The cube curve is the only one that gives uniformly increasing acceleration to the follower, starting from zero, as indicated by the straight

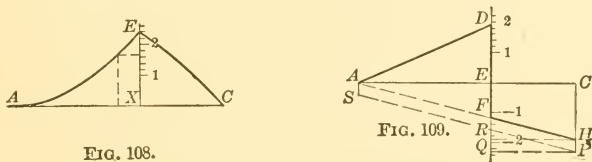

FIG. 108.

FIG. 109.

FIG. 108.—(Duplicate) VELOCITY DIAGRAM FOR CUBE CAM
 FIG. 109.—(Duplicate) ACCELERATION DIAGRAM FOR CUBE CAM

inclined line *A D* in Fig. 109. The disadvantage of the cube curve, however, is that it gives an extremely large cam for a given maximum pressure angle, if it is used in the same way that the preceding curves are used, that is, if it is made up of two similar arcs placed in reverse order. If the cube curve were so drawn it would be made up of two arcs similar to *A E*, Fig. 106, and the pressure angle factor would be 5.20 as compared, for example, with 3.46 for the parabola, and the maximum radius of the cam would be 5.47 against 3.80 for the parabola. Because of the similarity of method of construction of the

cube curve and the parabola, and because the large size of the symmetrical cube cam renders it impractical for most cases, its drawing will be omitted, and instead, a modified and more practical construction of the cube cam will be illustrated and explained in the following paragraphs.

241. CUBE BASE CURVE UNSYMMETRICALLY APPLIED FOR BEST ADVANTAGE. This modified cube curve will be referred to as CUBE CURVE, CASE I. Its features are that it retains the very low starting values of the regulation or symmetrical cube cam, and at the same time keeps down the size of the cam by using the regulation cube curve for the first half of the follower's motion and then using a short arc of another cube curve for the retardation in such a way that the maximum acceleration and retardation values shall be equal. In order to use this base curve several formulas are necessary and they, together with their notation, are given in the following paragraph.

242. NOTATION AND FORMULAS FOR CUBE CURVE CAM, CASE I:

- h = distance moved by the follower.
- a = pressure angle.
- l = length of part of cam chart corresponding to follower's motion.
- x = length of cam chart during which acceleration takes place.
- $x_1, x_2 \dots$ = arbitrary lengths of cam chart taken for purposes of constructing chart base curve.
- $y_1, y_2 \dots$ = length of ordinates of cam chart corresponding to the values of $x_1, x_2 \dots$
- r = radius of pitch circle of cam.
- b = angle turned through by cam in degrees during follower's motion.

The general formulas are:

$$l = 2.427 h \cot a \quad \dots \quad (1) \quad x = .618 l \quad \dots \quad (2)$$

$$y = \frac{h \left(\frac{x}{l}\right)^3}{2\sqrt{5} - 4} \text{ from zero to } x \quad \dots \quad (3)$$

$$y = h \frac{3 \left(\frac{x}{l}\right) - \left(\frac{x}{l}\right)^3 - (\sqrt{5} - 1)}{3 - \sqrt{5}} \text{ from } x \text{ to } l \quad \dots \quad (4)$$

$$r = \frac{180 l}{\pi b} \quad \dots \quad (5)$$

243. **PROBLEM 25.** CUBE CURVE CAM, CASE I. Required a cube curve cam with unsymmetrical cube curve arcs in which the follower shall:

- (a) Rise 1 unit in 60° turn of the cam.
- (b) Fall 1 " " 60° " " " "
- (c) Remain stationary for 240° turn of the cam, and
- (d) The maximum pressure angle shall be 30° .

Substituting the values given in the data in the formulas in the preceding paragraph, $l = 4.20$, $x = 2.60$ and $r = 4.0$. With these values, the rectangle $A B C R$, Fig. 106, for the cam chart may be

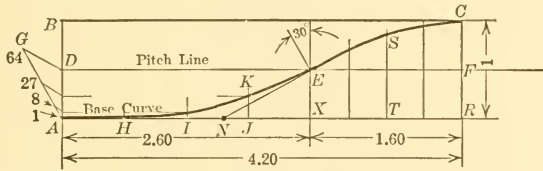

FIG. 106.—(Duplicate) CUBE BASE CURVE, CASE I

drawn, $A R$ being made equal to l , $A X$ equal to x , and $R C$ equal to h . The curve $A E$ may be drawn graphically by dividing $A X$ into four equal parts, $A D$ into four unequal parts, as shown in Fig. 106, and projecting the division points until they meet, as at K . $A D$, which is one-half of $A B$, is divided into the four unequal parts as follows: Draw a straight line $A G$ in any convenient direction about as shown; make its length 64 units according to any convenient scale; with the scale still in place mark the 1st, 8th and 27th division points on $A G$ and from each of these points draw lines parallel to $G D$ until they intersect the side $A D$ of the rectangle; from the latter points draw horizontal lines until they intersect their corresponding ordinates, as at K . Or, the values of these ordinates, as at $J K$, may be computed by formula (3) of the preceding paragraph by substituting the following values for x : $x_1 = \frac{1}{4}x$, $x_2 = \frac{1}{2}x$, $x_3 = \frac{3}{4}x$. The computed values of y_1, y_2, y_3 , are .008, .063, .211, respectively, and these are laid off at H, I , and J in Fig. 106.

244. The portion of the cube curve from E to C , Fig. 106, is found by taking a series of any number of equally spaced ordinates, four being used in this problem and one of them marked at $T S$. The values of these ordinates are computed from formula (4) of paragraph 242, and are as follows: $y_1 = .50$, $y_5 = .71$, $y_6 = .87$ (shown

at $S T$), and $y_7 = .95$. The corresponding values of x_4, x_5, \dots which were substituted for x in equation (4) in obtaining these values were $x_4 = x, x_5 = x + \frac{1}{4}(l - x), x_6 = x + \frac{1}{2}(l - x), \text{etc.}$

245. The pitch circle of the cam is drawn with $O D$, Fig. 107, as a radius and is equal to $r = 4.00$, obtained from equation 5. The values as found for the cam chart may be now transferred to the cor-

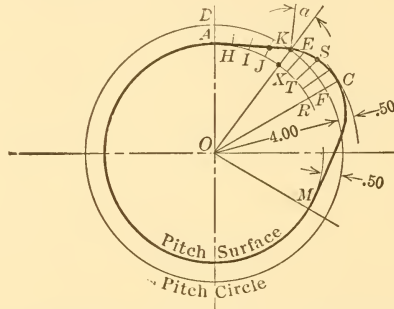

FIG. 107.—(Enlarged) PROBLEM 25. CUBE BASE CAM, CASE 1

respondingly placed radial lines from A to R , or the values as computed from formulas (3) and (4) may be laid off directly on these radial lines without drawing the cam chart at all.

246. The characteristic velocities, accelerations and retardations produced by this case of the cube curve cam are shown in Figs. 108 and 109, respectively. From the latter it may be seen that the

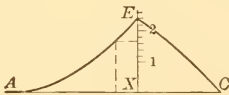

FIG. 108.

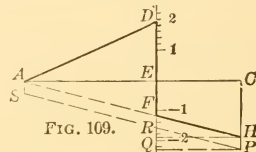

FIG. 109.

FIG. 108.—(Duplicate) VELOCITY DIAGRAM FOR CUBE CAM
 FIG. 109.—(Duplicate) ACCELERATION DIAGRAM FOR CUBE CAM

acceleration and retardation lines, $A D$ and $F H$, respectively, are straight inclined lines, characteristic of the cube curve, as pointed out in paragraph 240. When the retardation line $F H$ is extended, as shown by the long-dash line, Fig. 109, it passes through the zero point of the diagram. A cam with this characteristic may have particular advantages in some instances, one of which will be referred to later in the discussion of the relative strength of springs necessary to return the follower.

where a equals the assigned pressure angle, h equals follower motion, and t equals fraction of stroke assigned to acceleration.

254. EXERCISE PROBLEM 26a. CIRCULAR BASE CURVE CAM, CASE II. Required a cam with a circular base curve in which the follower shall:

- (a) Rise 2 units in 75° turn of the cam.
- (b) Fall 2 " " 75° " " " "
- (c) Remain stationary for 210° turn of the cam.
- (d) Accelerate for .7 of its stroke, and in which
- (e) The maximum pressure angle shall be 30° .

255. THE USE OF THE CUBE CURVE FOR obtaining extremely low starting velocities is illustrated in Fig. 115. The cam is built up

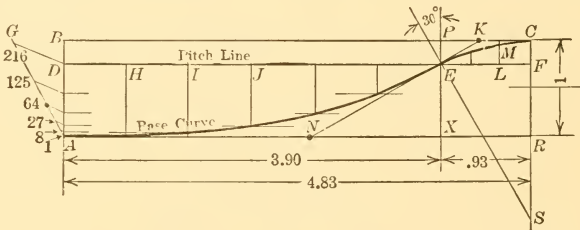

FIG. 114.—(Enlarged) CUBE BASE CURVE, CASE 2

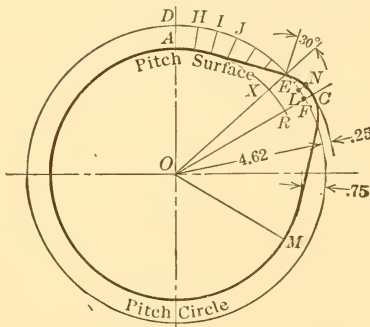

FIG. 115.—(Enlarged) PROBLEM 27. CUBE BASE CURVE CAM, CASE 2

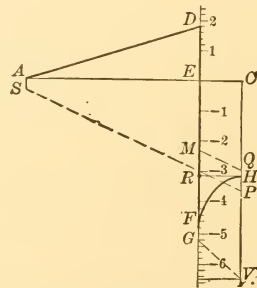

FIG. 117.—(Duplicate) ACCELERATION DIAGRAM FOR CUBE CAM, CASE 2

from a specially long arc of the cube base curve and it has a short circular base arc for easing off at the end. The chart and the base curve for this cam are shown in Fig. 114. The low-starting velocities are due to the fact that the follower has $\frac{3}{4}$ of its stroke to reach maximum velocity. This gives only $\frac{1}{4}$ stroke for retardation which attains a very high value near the end of the stroke ranging from 4.8 to 3.2, as shown in Fig. 117. This, of course, becomes the acceleration

value at the beginning of the return stroke. Herein lies the disadvantage of this cam. It is useful only where extremely slow starting velocity is required at one end of the stroke and where a rapid change of velocity at the other end of the stroke is immaterial. It would require a powerful spring to keep the follower roller in contact with the cam at high speeds, and if it were used on a positive drive cam would cause rapid wear at the beginning of the return stroke.

256. PROBLEM 27. CUBE CURVE, CASE II. Required a cube curve cam with a circular arc for easing-off radius in which the follower:

- (a) Rises 1 unit in 60° turn of the cam.
- (b) Falls 1 " " 60° " " " "
- (c) Remains stationary for 240° turn of the cam.
- (d) Accelerates during $\frac{3}{4}$ of the stroke.
- (e) The maximum pressure angle to be 30°.

257. In solving the above problem the length AX , Fig. 114, of that part of the chart which is given over to the cube curve is first found by the formula,

$$x_1 = \frac{3th}{\tan a}, \text{ where}$$

t = the fractional part of the follower's motion devoted to acceleration.

h = the total motion of the follower.

a = the pressure angle.

x_1 = the length of chart under the cube curve.

x_2 = the length of chart under the circular easing-off arc.

Substituting the values given in problem 27,

$$x_1 = \frac{3 \times .75 \times 1}{.577} = 3.90.$$

258. The length XR of chart, Fig. 114, necessary for the easing-off circular arc may be computed by the formula,

$$x_2 = \frac{h(1-t)}{\tan \frac{1}{2}a} = \frac{.25}{.268} = .93.$$

Or, the length XR may be found directly by drawing NEK so that it is tangent to the cube curve at E . The angle KEF will

then be equal to the pressure angle. Make $K C$ equal to $E K$. The point C will then be at the end of the chart. The center for the arc $E C$ will then be on the line $C R$ extended, and at a point S which must also be on the perpendicular to $N E K$.

259. To find points on the cube base curve $A E$, Fig. 114, divide $D E$ into any convenient number of equal parts, six being used in the illustration. Draw vertical lines through each of the division points as at H, I, \dots . Draw a line $A G$ inclining upward from A in any convenient direction and make the distance $A G$ equal to the cube of the number of construction parts. Six parts having been chosen in this problem, $A G$ will be equal to the cube of 6, or 216 units in length laid off to any convenient scale. At the same time lay off the division points 1, 8, 27, etc., which are the cubes of 1, 2, 3, etc. Draw

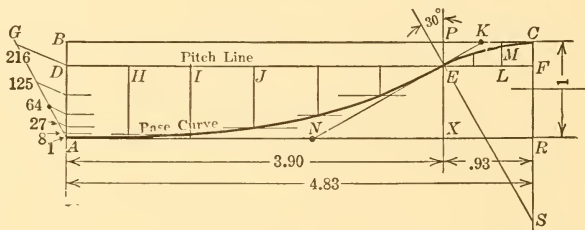

FIG. 114.—(Duplicate) CUBE BASE CURVE, CASE 2

the line $G D$, and then draw lines parallel to it through the points 1, 8, 27, etc., until they intersect $A D$. Project these intersecting points horizontally until they meet the corresponding verticals from H, I, \dots , thus giving points on the cube base curve $A E$.

260. The radius for the pitch circle of the cam will be,

$$r = \frac{l \times 360}{2 \times \pi \times b} = \frac{4.83 \times 360}{6.28 \times 60} = 4.62,$$

where l = length of chart used for rise of follower and,
 b = angle during which the follower is moving.

With the above value of r the circle through D is drawn in Fig. 115. The arc $D E F$ will be equal in length to the line $D E F$ in Fig. 114 when drawn to the same scale, and it should be similarly divided and the radial lines at H, I, \dots made equal to the similarly lettered ordinates in the chart. The curve $A E C$ thus obtained will be the pitch surface of the cam.

261. EXERCISE PROBLEM 27a. CUBE CURVE, CASE II. Required a cube curve cam with a circular easing-off arc in which the followe

- (a) Rises 3 units in 90° turn of the cam.
- (b) Falls 3 " " 90° " " " "
- (c) Remains stationary 180° " " " "
- (d) Accelerates during .70 of its stroke.
- (e) The maximum pressure angle to be 30° .

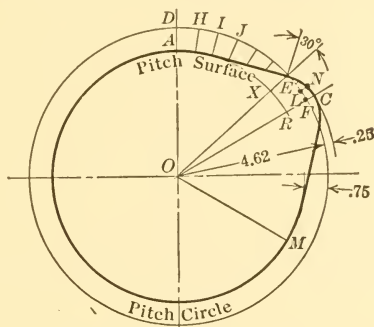

FIG. 115.—(Duplicate) CUBE BASE CURVE CAM, CASE 2

262. TANGENTIAL CAM, CASE II. The tangential cam, as stated in paragraph 218, is made up of straight-line sides with a circular arc for rounding off the end of the lobe. When the length of the straight surface of the cam is not specified, or when the portion of the stroke during which the follower accelerates is not given in the data, the tangential type of cam works out to good advantage. But when either of the above items is included in the data for the tangential cam it may conflict with the proper cam angle which should be allowed for the follower motion, as illustrated in the following problem, which contains the same data as the two previous problems. The possible difficulty met with in using the tangential cam arises from high accelerations that may be produced.

263. PROBLEM 28. TANGENTIAL CAM, CASE II. Required a tangential cam with a circular easing-off arc in which the follower:

- (a) Rises 1 unit during 60° turn of the cam.
- (b) Falls 1 " " 60° " " " "
- (c) Remains stationary for 240° " " " "
- (d) Accelerates during $\frac{3}{4}$ of its stroke.
- (e) The maximum pressure angle to be 30° .

264. The cam may be constructed directly by substituting values

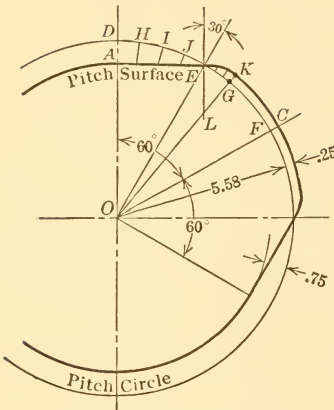

FIG. 119.—(Enlarged) PROBLEM 28. TANGENTIAL BASE CURVE CAM, CASE 2

given in the data in the general formulas given in paragraph 222, and then laying out the results as in Fig. 119. In the present problem OA , Fig. 119 equals s as found in paragraph 222, $AE = t$, $OD = p$, $OC = d$, angle $DOC = b$, angle $DOK = c$, and $LE = e$. The radius r of the roller and the minimum radius w of the working surface are not shown in the illustration but may be readily added if called for. The radius of the roller, however, cannot be greater than EL . The numerical results found by substituting the values given in the data in the series of formulas referred to above are as follows:

$$s = 4.84 \quad t = 2.79 \quad p = 5.58 \quad d = 5.84 \quad c = 39 \frac{5^\circ}{8} \quad e = 1.47.$$

265. If it is desired to construct the cam chart for the purpose of determining the velocity and acceleration diagrams later, it may readily be done:

(1) By making the length of chart AR , Fig. 118, equal to the length of the arc DF on the cam drawing,

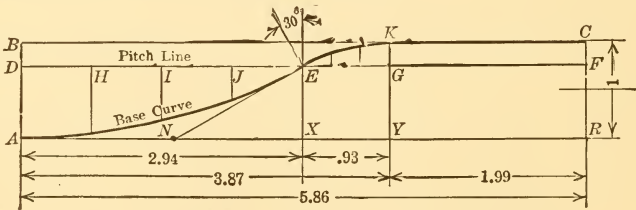

FIG. 118.—(Enlarged) TANGENTIAL BASE CURVE, CASE 2

(2) by laying off the pitch line DF on the chart and subdividing the same as the arc DF on the cam is subdivided,

(3) by transferring the radial lines at H, I, \dots from the cam to the chart and drawing them as vertical lines, thus obtaining points for the base curve AEC .

266. It will be noted that an attempt to construct a tangential cam in cases such as the one here represented may result in extremely large retardation or acceleration values, as shown in Fig. 121, the practical result of which will be a "hard-turning" spot at a point on

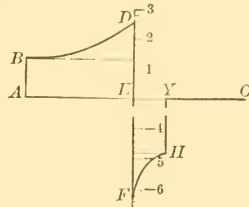

FIG. 121.—(Duplicate) ACCELERATION DIAGRAM FOR TANGENTIAL CAM, CASE 2

the cam corresponding to *E*, Fig. 119, and continuing, in lessening degree, to *K*.

267. EXERCISE PROBLEM 28a. TANGENTIAL CAM, CASE II. Required a tangential cam with a circular easing-off arc in which the follower:

- (a) Rises 2 units during 75° turn of the cam.
- (b) Falls 2 " " 75° " " " "
- (c) Remains stationary for 210° " " " "
- (d) Accelerates during .70 of its stroke.
- (e) The maximum pressure angle to be 30° .

SECTION VII.—CAM CHARACTERISTICS.

268. METHOD OF DETERMINING VELOCITIES AND ACCELERATIONS.

The velocity and acceleration values in the diagrams shown in Figs. 72 to 121 may be found by graphical methods which are simple and quite accurate enough for most practical purposes if precision in drawing is followed. The graphical method applies to all forms of cams and starts with the cam chart. Its application, however, is illustrated only in connection with the circular cam chart in Fig. 98, it being unnecessary to add similar lines to all the other chart drawings, as the constructions would be the same in every case.

269. THE USE OF TIME-DISTANCE AND TIME-VELOCITY DIAGRAMS.

The chart curve AEC , Fig. 98, for our present purpose, may be

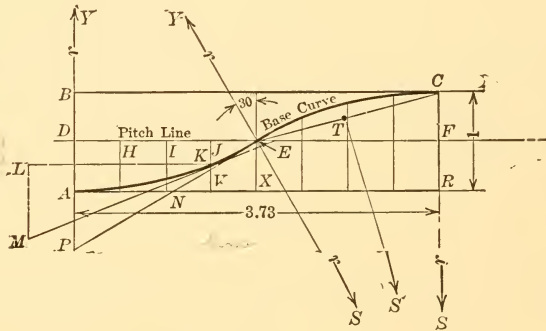

FIG. 98.—(Duplicate) CIRCULAR BASE CURVE, CASE 1

termed time-distance curve in which the abscissa AR represents time, and the ordinates parallel to AB represent distances traveled by the follower at corresponding times. If, then, the time-distance curve were a straight inclined line, the velocity of the follower would be constant. We may consider, for the instant, that the time-distance curve is straight at E and draw a straight line, EP , tangent at that point. If this were the time-distance line and if it were continued for a time period represented by ED , the follower would have moved the distance PD in the time represented by ED . If ED is consid-

ered as a unit of time, then $P D$ becomes a measure of velocity and its length is laid off in Fig. 100, at $X E$ which is at the center of the time-velocity diagram. The length $A C$ of the velocity diagram may be any convenient value for the purpose of comparison. The distance $D E$, Fig. 98, or one-half the length of the cam chart, was selected as a time unit because it is a convenient length and because the length of one-half of each cam chart represents the same amount of time in each of the chart drawings. This is because the data are the same in all the cams represented in Figs. 71 to 119. To find other points on the time-velocity diagram, divide the time-distance curve by a number of equally spaced ordinates as shown at J, I, H , Fig. 98. The tangent to the curve at K , on the ordinate $J V$, is $K M$, and the time unit $K L$ is equal to $D E$. Then, from the same reasoning as given above for the point E , $L M$ becomes a measure of the velocity of the follower at K , and it is laid off at $M L$ in Fig. 100. Similar constructions are repeated at the other points and the time-velocity diagram completed.

270. THE TIME ACCELERATION DIAGRAMS ARE FOUND GRAPHICALLY from the time-velocity diagrams by similar constructions. In Fig. 100 a tangent $E S$ is drawn to the time-velocity curve at E and if the

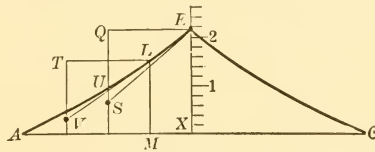

FIG. 100.—(Enlarged) VELOCITY DIAGRAM FOR CIRCULAR BASE CURVE CAM

velocity of the follower is continued along this line for a time represented by $E Q$ it will lose a velocity of $Q S$ in the time $E Q$. Such loss in velocity is retardation and consequently the distance $S Q$ is laid off at $E D$ at the center of the time-acceleration diagram in Fig. 101. The line $E S$ in Fig. 100 was drawn to the left, and consequently downward to make the drawing more compact. In this way retardation instead of acceleration was found logically. Had the tangent line $E S$ been drawn to the right, and consequently upward, the value $Q S$ would have been found just the same and would have been called acceleration. The length of the acceleration diagram, $A C$, in Fig. 101 may be taken any value; also, the time unit $E Q$ in Fig. 100 may be taken any value entirely independent of the time unit used in Fig. 98, so long as the same length of line is taken in all the

sents .750 foot per second to the same scale. Therefore the acceleration is .750 foot per second per $1/48$ second or 36.00 feet per second per second. The scale on ED , Fig. 101, would then be graded so that a mark at 36.00 would fall at D .

Another set of construction lines for obtaining an ordinate in the acceleration diagram is shown at $LT V$, Fig. 100, where LT is the same length as EQ , and VT is equal to the acceleration and is laid off at VT in the acceleration diagram, Fig. 101.

271. DEGREE OF PRECISION OBTAINED BY GRAPHICAL METHOD. In Fig. 98 the tangent lines may be drawn with precision because the curve AE is an arc of a circle, but in the other curves the center of curvature for each of the construction points is not known and the tangent must, therefore, be drawn by eye. Even here considerable precision may be obtained if, in so drawing the tangent, it is remembered that the tangent at L , Fig. 100, for example, will be practically the same distance from U as it is from E when it passes each of these points, provided U and E are on ordinates equally spaced, and provided also that the curve AE has a fairly uniform rate of curvature on both sides of L . If the radius of curvature to the right of L should grow noticeably shorter than the radius of curvature to the left of L , the tangent at L would pass a little closer to U than to E . If, in addition to using such judgment as here indicated in the drawing of tangents to irregular curves, a sufficient number of points are taken closely together, and if the newly derived curve is drawn smoothly through the average positions of plotted points, a remarkable degree of accuracy may be obtained by the graphical method of obtaining velocity and acceleration diagrams.

272. COMPARISON OF RELATIVE VELOCITIES AND FORCES PRODUCED BY CAMS HAVING DIFFERENT BASE CURVES. This comparison, which may be made by studying the several velocity and acceleration diagrams in Figs. 72 to 121, is also shown in the accompanying table where the maximum velocities of the follower are shown in Column 2, and the maximum acceleration and retardation values in Columns 3 and 4. Since force equals acceleration multiplied by mass, the direct effort required to move the follower is proportional to the acceleration, and, therefore, the relative direct force needed to operate the follower for various cams is also shown in Columns 3 and 4. The retardation values in Column 4 represent the relative pressures exerted by the follower against the cam surface in slowing up where a positive drive cam is considered. They also represent the relative

sizes of counterweights where a gravity return is used. In the cam with the straight-line base there would be violent shock at the start and the cam would "stick" and require considerable direct power, but after that it would be necessary only to overcome friction. The parabola, it will be noted from the table and from Fig. 93, requires the least direct effort, considering the entire cycle of the follower. This effort is represented by unity for purpose of comparison. The circular base curve cam, Case II, Fig. 113, requires a trifle less effort than the parabola cam while on acceleration on the forward stroke, but 2.86 times the effort of the parabola while the follower is on acceleration during the return stroke where a double-acting cam is used. For a single-acting cam the values given in Column 4 show the relative forces necessary to sufficiently accelerate the follower on the return stroke so as to keep it in contact with the cam.

TABLE SHOWING RELATIVE MAXIMUM VELOCITY, ACCELERATION AND POWER FOR EACH TYPE OF CAM

| FORM OF CAM | RELATIVE MAXIMUM VELOCITIES | RELATIVE AMOUNTS OF DIRECT FORCE NEEDED TO OPERATE CAM DURING | |
|---|-----------------------------------|---|-----------------------|
| | | Acceleration Col. 3 | Retardation Col. 4 |
| Col. 1 | Col. 2 | | |
| All-logarithmic..... | 1.28 | — | — |
| Logarithmic combination..... | 1.40 | 1.82 | 1.82 |
| Straight line..... | 1.00 | — | — |
| Straight-line combination curve ($r = h$) | 1.31 | 1.99 | 1.99 |
| Crank curve..... | 1.57 | 1.25 | 1.25 |
| Parabola..... | 2.00 | 1.00 | 1.00 |
| Tangential curve, Case I..... | 2.09 | 1.58 | 1.10 |
| Circular curve, Case I..... | 2.16 | 1.44 | 1.44 |
| Elliptical curve..... | 2.28 | 1.60 | 1.60 |
| Cube curve, Case I..... | 2.40 | 1.95 | 1.95 |
| Circular curve, case II..... | 2.16 | 0.96 | 2.86 |
| Cube curve, Case II..... | 2.79 | 1.80 | 4.80 |
| Tangential curve, Case II..... | 3.39 | 2.55 | 6.39 |

273. CAM FOLLOWER RETURNED BY SPRINGS. Although the cam built from the parabola chart pitch curve gives the smoothest motion and requires the least direct power to operate it so far as the cam and follower only are concerned, there may be other considerations in the

design that make or appear to make some other form of chart pitch curve more desirable. For example, when a follower is returned by a positive drive parabola cam, or when it is returned by gravity, the parabola cam gives the best action because the pull on the follower is constant all the time, but when the follower is returned by a spring, the spring reacts on the cam with a uniformly increasing pressure during the outstroke as represented by the straight inclined dash-line SP in Fig. 93, and with a reverse uniformly decreasing pressure during the instroke.

274. IF THE SPRING PRESSURE ACTING ON THE CAM IS ZERO when the follower is at rest in its lowest position, the spring compression line would be represented by the straight line AN , Fig. 93, starting at A and inclined so as to touch the retardation line as at F . Inasmuch as there should always be some compression in the spring, even when the follower is at rest, a margin of compression will be taken as illustrated at AS . The practical spring compression line will, therefore, be SP parallel to AN .

As the follower moves out, its acceleration during the first part of the stroke produces increasing pressure between the cam surface and the spring-actuated follower as represented by the increasing length of the ordinates from SB to RD . At midstroke the follower begins to slow up. In the case shown in Fig. 93, the slope of the spring pressure line was taken so as to have the same spring pressure ($RF = SA$) on the cam at midstroke as it has at the beginning. The line SP could have been given a steeper slope if a larger margin of pressure than RF had been desired at midstroke. This would have required a heavier spring. From midstroke to the end there is again an increasing margin of pressure, the maximum being represented by the difference between the ordinates PH and RF . The full strength of the spring which would have to be used would be represented by the ordinate PC .

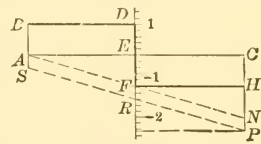

FIG. 93.—(Duplicate) ACCELERATION DIAGRAM FOR PARABOLA CAM

275. RELATIVE STRENGTH OF SPRING REQUIRED FOR CRANK, TANGENTIAL, CUBE AND PARABOLA BASE CURVE CAMS. Although the parabola cam, with its perfect action as described in paragraph 214, permits of the use of a light spring when a single spring is used to return the follower, the crank curve, tangential curve and cube curve cams may each be designed to operate with somewhat lighter springs. Spring compression lines for each of the three last-men-

tioned cams are shown at SP in Figs. 89, 97, and 109, and the maximum compression required of a single spring in each case is 1.75, 2.35, and 2.30 as compared with 2.40 for the parabola cam as shown in Fig. 93. The return spring pressure between the follower roller and the cam surface, when the crank base curve is used, is more nearly uniform throughout the entire stroke than it is with any other

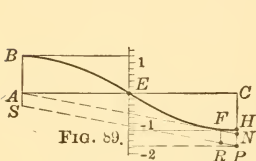

FIG. 89.—(Duplicate) ACCELERATION DIAGRAM FOR CRANK CURVE CAM

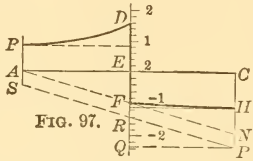

FIG. 97.—(Duplicate) ACCELERATION DIAGRAM FOR TANGENTIAL CAM

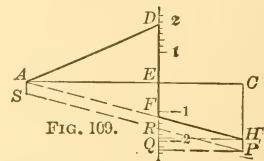

FIG. 109.—(Duplicate) ACCELERATION DIAGRAM FOR CUBE CAM

FIG. 89.—(Duplicate) ACCELERATION DIAGRAM FOR CRANK CURVE CAM
 FIG. 97.—(Duplicate) ACCELERATION DIAGRAM FOR TANGENTIAL CAM
 FIG. 109.—(Duplicate) ACCELERATION DIAGRAM FOR CUBE CAM

type of cam, as may be noted from the maximum and the average ordinates between the acceleration-retardation curve and the spring pressure line, SP , in the several diagrams.

276. CUBE CURVE CAM SPECIALLY ADAPTED for a follower returned by a spring. The cube curve cam possesses one characteristic over the others in that the pressure between the cam and the follower is absolutely uniform during the latter part of the up-stroke and the first part of the down-stroke when the follower is returned by a spring, as shown by the parallel lines FH and RP , Fig. 109. This gives an advantage of smooth running and uniform wear when the spring is under its greatest compression.

277. THE PRESSURE BETWEEN THE SPRING-ACTUATED FOLLOWER AND THE CAM IS VARIABLE throughout the stroke in all cams except during part of the stroke with the cube curve cam. And it may

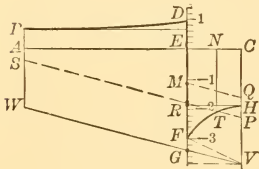

FIG. 113.—(Duplicate) ACCELERATION DIAGRAM FOR CIRCULAR BASE CURVE CAM, CASE 2

readily happen that the acceleration called for by the cam is so great that the spring will not be strong enough to keep the follower roller against the cam surface as may be specially noted at or near the beginning of the return stroke. This is illustrated in Fig. 113 where the spring pressure against the follower which would be necessary to hold it to the cam is represented by FE , whereas, if a spring of the same strength as

for the cube curve cam, Fig. 109, were used the pressure at the

phase E , Fig. 113, would be only RE . This means that the cam will "run away" from the follower, because the spring is not strong enough during the part of the stroke represented by TFR to press the follower against the rapidly receding cam surface.

278. IN ORDER TO KEEP THE FOLLOWER ROLLER AGAINST THE CAM SURFACE where cams with large retardation values are used, as in Figs. 77, 85, 113, 117, and 121, a comparatively heavy spring is required which will be unnecessarily strong during a very large part of the stroke, or else two springs will be required, the second one to come into action when needed. Both cases are illustrated in Fig. 113. A single heavy spring that will exert a pressure represented by WV

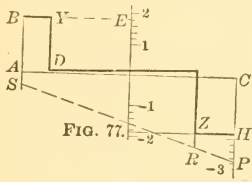

FIG. 77.

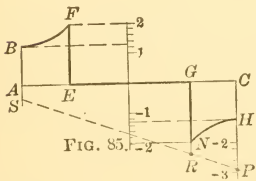

FIG. 85.

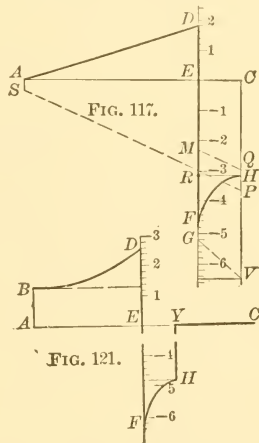

FIG. 117.

FIG. 121.

FIG. 77.—(Duplicate) ACCELERATION DIAGRAM FOR LOGARITHMIC-COMBINATION CAM
 FIG. 85.—(Duplicate) ACCELERATION DIAGRAM FOR STRAIGHT-LINE-COMBINATION CAM
 FIG. 117.—(Duplicate) ACCELERATION DIAGRAM FOR CUBE CAM, CASE 2
 FIG. 121.—(Duplicate) ACCELERATION DIAGRAM FOR TANGENTIAL CAM, CASE 2

will keep the follower roller against the cam surface at all times, the minimum pressure between the two occurring at FG . Or, a single and much lighter spring exerting a pressure represented by SP , Fig. 113, may be used, and then a second and shorter spring with an initial compression represented by ME may be so placed as to come into action at E so that the combined pressure of the two springs on the follower is ME plus RE equal FE . This means that the combined pressure of the two springs will be just sufficient to keep the follower roller against the cam at phase E , and that the total pressure of the two springs at the end of the stroke will be represented by CV , thus giving an excess pressure represented by HV at the end of the stroke.

The base curves that are best suited for spring-return followers will be seen by comparing the acceleration diagrams in Figs. 73 to 121 to be the crank curve, parabola, tangential curve, Case I, and the cube curve, Case I. The logarithmic combination and straight-line combination curves come next in order.

279. ACCURACY IN CAM CONSTRUCTION. It need scarcely be pointed out that the pitch surfaces of cams should be constructed with considerable accuracy and the working surfaces carefully fin-

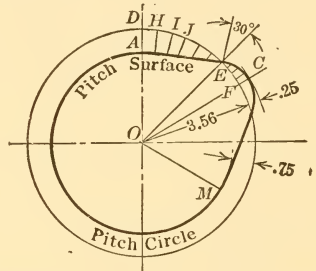

FIG. 111.—(Duplicate) CIRCULAR BASE CURVE CAM, CASE 2

ished, if definite results are required, for, it may be seen by comparing the pitch surfaces of several of the cams illustrated in Figs. 71 to 119 that a relatively small difference in form may make a large difference in the velocity, acceleration, and force or pressure, under which the follower operates. For example, the circular curve cam,

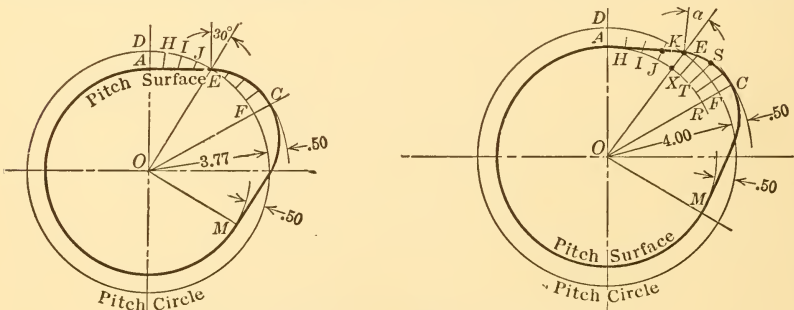

FIG. 103.—(Duplicate) ELLIPTICAL BASE CURVE CAM

FIG. 107.—(Duplicate) CUBE BASE CURVE CAM, CASE 1

Case II, Fig. 111, and the cube curve cam, Case II, Fig. 115, are apparently quite similar in form, though varying in sizes, yet the maximum accelerations which they impose on the follower on the return stroke are quite different, being 2.9 and 4.8 respectively, as shown in Figs. 113 and 117. Also the cube curve cam, Case I, Fig. 107 and the elliptical cam, Fig. 103, are much alike, yet their velocity

lines and their acceleration lines, Figs. 109 and 105, are different in every way and if a spring were used to return the follower, the one for the elliptical cam would have to be enough heavier to carry 1.7 more compression at the end of the stroke than the one for the cube cam, assuming an initial pressure of AS , in each one. The value 1.7 is found by comparing the lengths CP in Figs. 109 and 105.

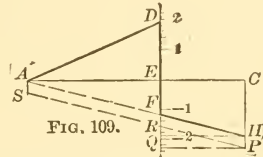
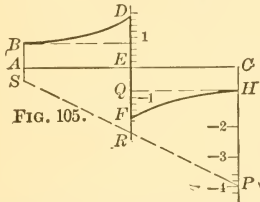

FIG. 105.—(Duplicate) ACCELERATION DIAGRAM FOR ELLIPTICAL BASE CURVE CAM
FIG. 109.—(Duplicate) ACCELERATION DIAGRAM FOR CUBE CAM

280. REGULATION OF NOISE. If a cam follower, as for example a cam-operated disk valve, comes to rest on a seat at one end of its stroke, it is evident that it would be desirable for the follower to have the least possible velocity for at least a short distance before it reaches the seat, in order to provide against unnecessary striking velocity. Noise will be in some proportion to the velocity of the follower at the instant of seating. With this in mind, an examination of the velocity diagrams in Figs. 72 to 120 will show that the cube base curve, Case I, Fig. 106, gives by far the best results, for, the vertical ordinates of the velocity curve in Fig. 108 are very much smaller as the follower approaches A than they are in any other diagram, excepting Case II of the cube curve, Fig. 116, but in this instance the advantage is more than offset by the high retardation values at the end of the stroke as shown in Fig. 117. The circular curve, Case II, comes next in the matter of giving small velocity to the follower, Fig. 112, but it does not possess the advantage of the cube curve when a spring is used to return the follower. The crank curve cam is least adapted of all the cams where quiet seating of a follower is desired, as may be observed by noting that the velocity curve, Fig. 88, for this cam is convex upwards, whereas the others are straight or convex downwards and thus have smaller initial vertical ordinates and, therefore, lower velocity. The full practical advantage of cams which give low-seating velocities and consequently a more quiet follower action, is offset to a considerable extent where the follower operates a valve which must admit a comparatively large volume of gas or fluid quickly.

281. HIGH SPEED CAMS. Cams intended for use on high-speed machines should give the smoothest possible motion to the follower, that is, should be free from sudden variations of velocity during the stroke and from shock due to sudden starting and stopping. A study of the velocity diagrams, Figs. 72 to 120, shows that the all-logarithmic and the straight-line base curves, Figs. 72 and 80, give extreme velocity right at the start in all cases; and that the logarithmic-combination and straight-line combination cams will also give relatively high velocities at the start, Figs. 76 and 84. Therefore none of these cams would, in general, be suitable for high-speed work. Among the other cams some have an advantage at one end of the follower stroke where the rate of change in velocity is low, but they lose it at the other end where it is high as, for example, the cube cam Case II, as shown in Fig. 117; or they lose their advantage at the center or some intermediate point as in the elliptical cam, Fig. 105.

282. The cams specified in the preceding paragraph give relatively large sudden change of velocity to the follower either at one end of the stroke or the other, or at intermediate positions; and of the remaining cams, the parabola cam is the only one that gives absolutely uniform rate of change of velocity to the follower. The crank curve, the circular curve, Case I, and the tangential curve, Case I, give relatively good results, all being at a slight disadvantage compared with the parabola due to variations in acceleration of the follower. This disadvantage, however, is small, and these three cams, together with the parabola cam, should give best results where there is high speed, provided they are accurately designed and made.

283. BALANCING OF CAMS. In addition to the forms of the curves here discussed for the pitch surfaces of cams that are to run at high speed, it is necessary to design the cam and so place the weight that the cam will be as nearly balanced as possible. This matter of balancing is one of the greatest drawbacks to the use of the cam in high-speed work, for the very nature of a cam implies irregularity in form and hence difficulty in balancing. The face cam cut on a full circular disk as illustrated in Fig. 2 comes nearest to a natural balance of any of the forms of radial cams. The trouble due to lack of natural balance in ordinary radial cams may easily be so decided as to render them quite impracticable in many cases where high speed and large stroke are required, unless elaborate balancing problems are solved in connection with the cam design. Small radial cams with small strokes have been made to run at exceedingly high speeds.

The cylindrical cam, because of its natural balanced form with respect to the axis of rotation, is well adapted to high speeds.

284. PRESSURE ANGLE FACTORS FOR 20° , 30° , 40° , 50° , AND 60° FOR VARIOUS FORMS OF CAMS. Most of the base curves for cams are of such nature that it is only necessary to multiply the follower motion by a given factor and then multiply the product by 360 and divide by the number of degrees the cam rotates during the follower motion, to obtain the circumference of the pitch circle and the proper size of the cam for a given pressure angle. The logarithmic and tangential base curves are of such a nature that no one factor can be used for all data that include a common pressure angle. When these base curves are used the length of chart, if desired, must be computed by separate formulas for each problem. The logarithmic and tangential base curves are most easily applied by constructing the cam pitch surface directly from calculated values in each problem without the use of any chart whatever.

285. The factors for pressure angles for all base curves, excepting the logarithmic and tangential, are given in the accompanying Table of Factors for 20° , 30° , 40° , 50° and 60° . These factors are also laid off graphically in Fig. 132, thus enabling one to use intermediate values if desired. For partial comparison of the curves which have no general factor with those which have, the special factor in each case for the single comparative problem which has been used throughout in designing the cams in Figs. 70 to 121 is given in the following paragraphs, and these factors are plotted to give the dash lines in the accompanying chart for factors.

286. VARIED FORMS OF FUNDAMENTAL BASE CURVES. Several of the base curves are, or may be, used in practical work with variations

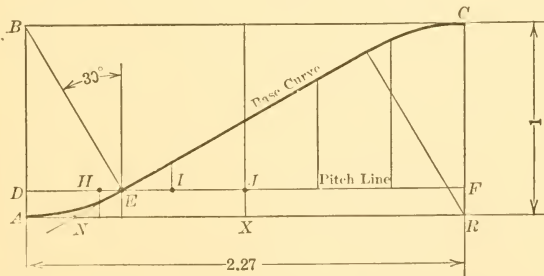

FIG. 82.—(Duplicate) STRAIGHT-LINE COMBINATION BASE CURVE

in details of construction, as, for example, in the straight-line combination curve, Fig. 82, the casing-off arc $A E$ has a radius $A B$ equal to the total rise of the follower, whereas it would be equally correct

TABLE OF PRESSURE ANGLE FACTORS

FOR BASE CURVES NOS. 1 TO 13 LISTED IN ORDER OF CORRESPONDING CAM SIZE FOR 30° ACCORDING TO DATA IN PARAGRAPH 176;
 NOS. 14 TO 16 ACCORDING TO DATA IN PARAGRAPHS 248 AND 249

| No. | Name of Base Curve. | FACTOR FOR A MAXIMUM PRESSURE ANGLE OF | | | | |
|-----|---|--|-----------|-----------|----------|----------|
| | | 20° | 30° | 40° | 50° | 60° |
| 1 | All-logarithmic..... | | | | | |
| 2 | Logarithmic combination..... | No general factors—see paragraphs 284 and 288 | | | | |
| 3 | Straight line..... | No general factors—see paragraphs 284 and 288 | | | | |
| 4 | Straight-line combination, radius equal to one-half fol- lower's motion..... | 2.75 | 1.73 | 1.19 | 0.84 | 0.58 |
| 5 | Elliptical curve, ratio of semi-axes : 2 to 4..... | 2.92 | 2.00 | 1.53 | 1.31 | 1.16 |
| 6 | Straight-line combination, radius equal to follower motion | 3.32 | 2.17 | 1.45 | 1.00 | 0.68 |
| 7 | Crank curve..... | 3.10 | 2.27 | 1.92 | 1.77 | 1.73 |
| 8 | Parabola..... | 4.43 | 2.72 | 1.87 | 1.32 | 0.91 |
| 9 | Tangential curve, Case I, length of straight surface not specified..... | 5.50 | 3.46 | 2.38 | 1.68 | 1.15 |
| 10 | Circular curve, Case I, symmetrical circular arcs..... | No general factors—see paragraphs 284 and 293. | | | | |
| 11 | Elliptical curve, ratio of semi-axes : 7 to 4..... | 5.67 | 3.73 | 2.75 | 2.14 | 1.73 |
| 12 | Cube curve, Case I, unsymmetrical cube curve arcs..... | 6.25 | 3.95 | 2.75 | 1.95 | 1.35 |
| | | 6.68 | 4.20 | 2.90 | 2.04 | 1.40 |
| | | 4.13+2.55 | 2.60+1.60 | 1.79+1.11 | 1.26+.78 | .87+.53 |
| 13 | Cube curve, Case III, symmetrical cube curves..... | 8.22 | 5.20 | 3.56 | 2.52 | 1.73 |
| 14 | Circular curve, Case II, unsymmetrical circular arcs..... | 5.67 | 3.73 | 2.75 | 2.14 | 1.73 |
| | | 4.26+1.41 | 2.80+.93 | 2.06+.69 | 1.60+.54 | 1.30+.43 |
| 15 | Cube curve, Case II, cube curve and circular arc..... | 7.60 | 4.83 | 3.37 | 2.42 | 1.73 |
| | | 6.18+1.42 | 3.90+.93 | 2.68+.69 | 1.89+.53 | 1.30+.43 |
| 16 | Tangential curve, Case II, length of straight surface specified..... | No general factors—see paragraphs 284 and 299. | | | | |

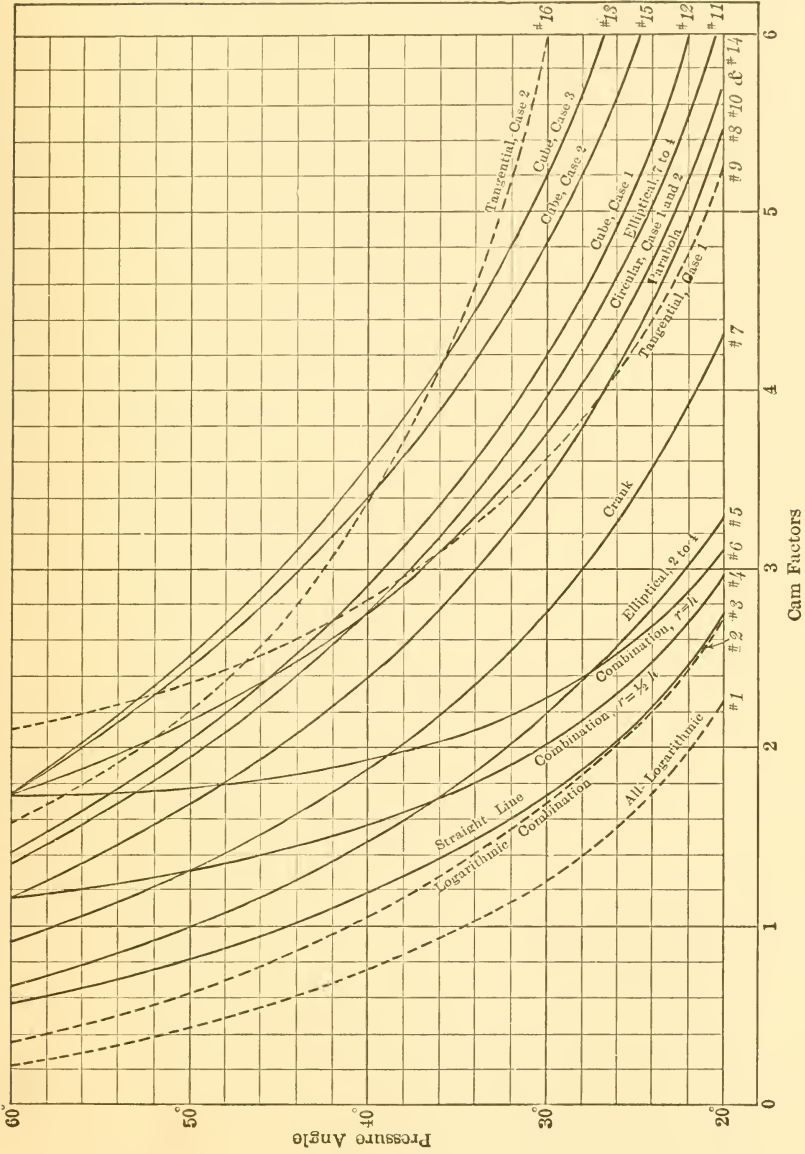

FIG. 132.—CHART OF BASE CURVES SHOWING RELATION BETWEEN PRESSURE ANGLES AND CAM FACTORS AND INDICATING ALSO RELATIVE SIZES OF CAMS REQUIRED BY VARIOUS BASE CURVES ALL HAVING SAME DATA

in principle to make this radius $\frac{1}{2} A B$. In this latter case the cam would be smaller for a given pressure angle, but the shock on starting and stopping would be greater. This case is not illustrated in Figs. 70 to 121 but is included under item 4 in the Table of Pressure Angle Factors, and also in the Chart of Pressure Curves, Fig. 132. Likewise the factors for the elliptical base curve having a ratio of 2 to 4 instead of 7 to 4, are given in item 5 in the Table and also in the Chart, Fig. 132. The factors for a cube base curve made up of symmetrical cube curves are also given in item 13 in the Table where it may be noted that this base curve gives an extremely large cam where small pressure angles are desired.

287. METHODS OF DETERMINING THE CAM FACTORS. The methods of computing the cam factors for various base curves are briefly described in the following paragraphs. The letter h in the following formulas represents the motion of the follower, and the letter a the maximum pressure angle.

288. ALL-LOGARITHMIC AND LOGARITHMIC-COMBINATION CURVES. These base curves do not have a constant factor for each pressure

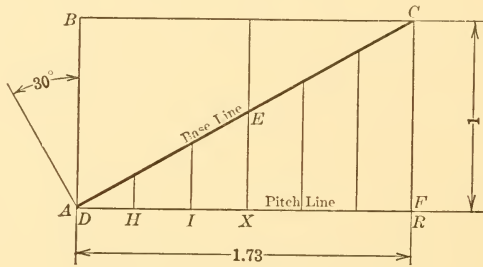

FIG. 78.—(Duplicate) STRAIGHT BASE LINE

angle. The radius for the pitch circle in each problem is found by computation and graphics as described in paragraph 182 *et seq.*

The factors for the data used in the charts shown in Figs. 70 and 74 are:

For all-logarithmic cam: 20°, 2.28; 30°, 1.28; 40°, .76; 50°, .42; 60°, .21.

For logarithmic-combination cam: 20°, 2.76; 30°, 1.69; 40°, 1.04; 50°, .62; 60°, .34.

289. STRAIGHT-LINE BASE. FIG. 78.

$$A R = F C \cot a = h \times \cot a = 1 \times 1.73 = 1.73.$$

only for the data that have been used in the cams illustrated in Figs. 71 to 119.

20°, 5.28; 30°, 3.62; 40°, 2.82; 50° 2.36; 60°, 2.09.

These values are shown in the dash line curve, No. 9, in Fig. 132.

294. CIRCULAR CURVE, CASE I, FIG. 98. The chord EC is perpendicular to the line ST which bisects the angle CSE . This angle

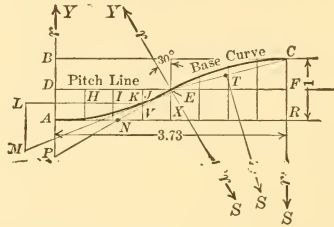

FIG. 98.—(Duplicate) CIRCULAR BASE CURVE, CASE I

is equal to the pressure angle. The line EF is perpendicular to CS . Therefore angle CEF equals one-half of the pressure angle. Then

$$EF = FC \cot \frac{1}{2} a \text{ and}$$

$$AR = 2 EF = h \cot \frac{1}{2} a = 1 \times 3.73 = 3.73.$$

295. ELLIPTICAL CURVE, FIG. 102. The length of the cam chart for the elliptical curve for a pressure angle of say 30° may be most

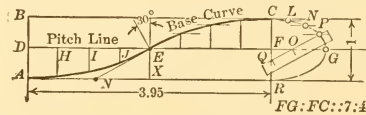

FIG. 102.—(Duplicate) ELLIPTICAL BASE CURVE

readily found by constructing several arbitrary elliptical charts, say four, each with a pressure angle factor, or length, of 2, 3, 4, and 5 respectively and each having a common height equal to the rise of the follower. Having constructed the elliptical curve in each of the charts, draw tangents in each case as at E , Fig. 102, and measure the angle ENX which will be the pressure angle corresponding to the factor or length assumed. Then, on any coordinate paper plot a curve with the pressure-angle factors as ordinates and the corresponding measured angles as abscissas. This curve will cross the ordinate

which passes through the assigned pressure angle, in this case 30° , and the length of ordinate will give the desired cam factor.

296. CUBE CURVE, CASE I, FIG. 106. The pressure angle factors for this case in which two unsymmetrical cube curve arcs are used

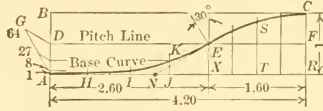

FIG. 106.—(Duplicate) CUBE BASE CURVE, CASE 1

are specially computed by the formulas given in paragraph 242. The value of l in formula (1) when $h = 1$, will give the factor for whatever pressure angle is assigned to a . For a pressure angle of 30°

$$l = 2.427 h \cot a = 2.427 \times 1 \times 1.73 = 4.20.$$

297. CIRCULAR BASE CURVE, CASE II, FIG. 110. The complete factors for this curve are the same as for the circular base curve,

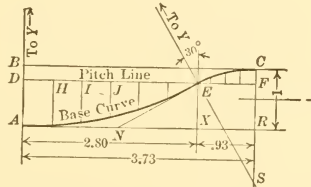

FIG. 110.—(Duplicate) CIRCULAR BASE CURVE, CASE 2

Case I, and are found in the same general way. In Case I the two arcs making up the base curve are equal; in the present case, they are unequal, and the formula deduced in paragraph 294 must be used for each arc. In this case, the first circular arc is required to lift the follower during $\frac{3}{4}$ of its stroke, and, therefore, the distance $A X$ in Fig. 110 will be,

$$A X = .75 h \cot \frac{1}{2} a = .75 \times 1 \times 3.73 = 2.80.$$

The second circular arc is used for the balance of the stroke and, therefore, the distance, $X R = .25 h \cot \frac{1}{2} a = .25 \times 1 \times 3.73 = .93$.

298. CUBE CURVE, CASE II, FIG. 114. In this case the cube curve is used for $\frac{3}{4}$ of the stroke and a circular arc for the remainder of the

stroke. The formula $x = \frac{3fh}{\tan a}$ is used to compute the part AX of the cam chart length. The value of h is the follower's total motion

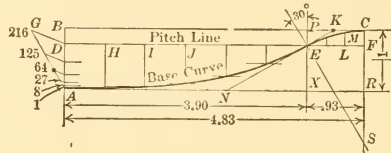

FIG. 114.—(Duplicate) CUBE BASE CURVE, CASE 2

and that of f is the fractional part of the follower's motion during which acceleration takes place. Then

$$AX = \frac{3 \times .75 \times 1}{.577} = 3.90.$$

The length XR is found in the same manner as in the preceding paragraph and is the same value, namely .93.

299. TANGENTIAL CURVE, CASE II, FIG. 118. This curve, like Case I of the tangential cam has no cam chart, unless it is specially

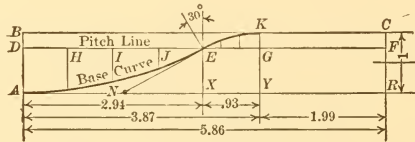

FIG. 118.—(Duplicate) TANGENTIAL BASE CURVE, CASE 2

desired to lay it out after the cam is drawn by making special computations based on the pitch circle as described in paragraph 225. For purposes of comparison the data used in this cam, as drawn in Fig. 119, are the same as for all other cams in Figs. 71 to 119, and for the data so used the pressure angle factors are:

20°, 13.02; 30°, 5.86; 40°, 3.36; 50°, 2.20; 60°, 1.57.

These values are shown in the dash line curve, 16, in Fig. 132.

SECTION VIII.—MISCELLANEOUS CAM ACTIONS AND CONSTRUCTIONS

300. VARIABLE ANGULAR VELOCITY IN THE DRIVING CAM SHAFT. The subject of variable angularity velocity in the drive shaft of a cam applies to all types of cams, but it is rarely met with except in oscillating cams. The reason for this is that in machinery, in general, the shafts that make a full turn do so with practically uniaxial velocity except in slow-advance and quick-return motions and in some special cases, and, therefore, the shaft that operates a cam, in general, is considered to have uniform angular velocity. But with the oscillating cam the motion must come through a crank and connecting rod, or eccentric and beam, or some other device, from a shaft which, in general, turns with uniform angular velocity, and which gives to the oscillating cam a variable angular velocity as illustrated in Fig. 133 where the unequal arcs $B_1 G_1$, $G_1 K_1$, $K_1 L_1$ represent the distances traversed by the cam pin B_1 while the main-shaft crank pin turns through the equal arcs $B G$, $G K$ and $K L$. The method of building a cam which has variable angular velocity will be illustrated in the following problem.

301. PROBLEM 29. OSCILLATING CAM HAVING VARIABLE ANGULAR VELOCITY, TOE AND WIPER TYPE. Required an oscillating wiper cam, operated by a crank and connecting rod from a main shaft to raise and lower a straight-toe follower through a distance of one unit while the crank shaft turns through 120° . Assume the following dimensions: Main crank radius, CB , 4 units, Fig. 133; connecting rod length, BB_1 , 20 units; cam-arm radius, $B_1 O$, 5 units; shortest cam surface radius, OA , 2 units. Find the distance the follower will move during each of three equal periods of time on the up-stroke.

302. The first step in the solution of the problem is to lay out the main crank center as at C in Fig. 133; then the crank-pin circle with a radius CB of 4 units, and next the connecting rod length of 20 units on the centerline as at EJ . Lay off the assigned 120° of crank-shaft motion symmetrically about the main centerline as at BCD and with B and D as centers and the length of the connecting rod

FIG. 138.—PROBLEM 33, DIAGRAM OF SLIDING VELOCITY

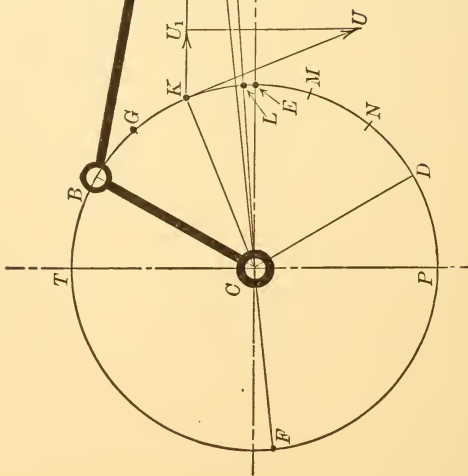
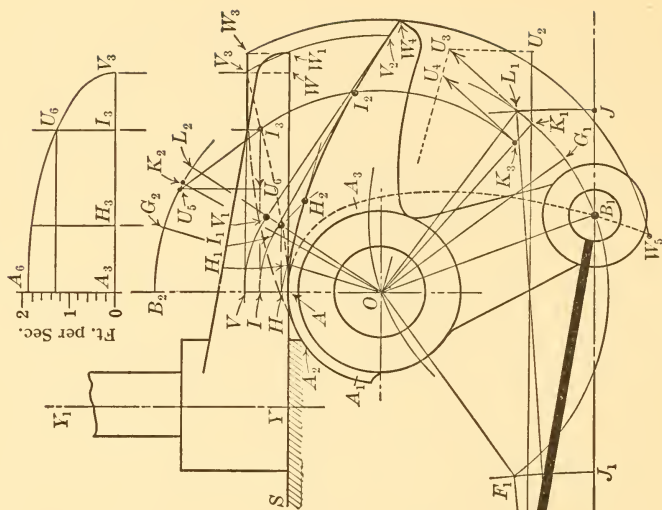

FIG. 133.—PROBLEM 29. OSCILLATING CAM WITH VARIABLE ANGULAR VELOCITY

as a radius draw two arcs intersecting on the horizontal centerline, thus locating B_1 . With C as a center and the connecting-rod plus the crank as a radius, draw the arc passing through J ; with C as a center and the connecting rod minus the crank as a radius, draw the arc passing through J_1 .

303. To find the center O of the cam shaft, Fig. 133, take B_1 as a center and the assigned cam-arm radius of 5 units, and draw an arc, on which the point O will be found later. On this arc find a point, by trial and error with the compass, which is the center of an arc which passes through B_1 and which intersects the two arcs through J and J_1 at the same elevation, as, for example, at L_1 and F_1 . The center point so found is the point O . The arc $L_1 B_1 F_1$ will then be the arc of swing for the center of the cam-arm pin, and the angularity of action between the connecting rod and the cam arm at the two extreme ends of the cam-arm swing will be approximately the same. Draw a vertical line through O and mark the assigned distance OA which is the shortest radius of the cam surface. The horizontal line through A will be the lowest position of the flat-surface follower toe. The distance AV is equal to the assigned motion for the follower.

304. Having completed the general layout of the assigned data, the cam surface AV_2 is found as follows: Draw the arc $B_2 L_2$ with a radius equal to OB_1 , and make the length $B_2 L_2$ equal to $B_1 L_1$. Revolve V about O until it meets the radial line drawn from L_2 to O , thus determining the point V_1 . At this latter point draw a line $V_1 V_2$ perpendicular to OV_1 . With the aid of any smooth-edged curved ruler draw a curved line tangent to AW at A and also tangent to $V_1 V_2$ at the point where it happens to come. Such a curved line is shown at AV_2 in Fig. 133. Any other curved line tangent to the straight lines AW and $V_1 V_2$ would have done the work in the same time but would have given slightly different intermediate velocities to the follower as will be explained in a later paragraph.

The actual working length AW of the follower toe is readily obtained by revolving the point of tangency V_2 about O until it meets the horizontal line through V at V_3 . Projecting V_3 down to AW and adding a short distance WW_1 to prevent a sharp-edge action, the practical length AW_1 is obtained. If the toe shaft is offset a distance AY the total length of follower toe will be YW_1 .

305. To find the distances moved by the follower toe during each of three equal periods while on the upstroke, divide BL , Fig. 133, into three equal parts as at G and K . With these points as centers

and with the connecting rod length as a radius construct short arcs intersecting $B_1 L_1$ as at G_1 and K_1 . Lay off the arcs $B_1 G_1$ and $B_1 K_1$ at $B_2 G_2$ and $B_2 K_2$ and draw the radial lines $O G_2$ and $O K_2$. Perpendicular to these radial lines draw other straight lines, tangent to the curved cam surface $A V_2$, thus obtaining the lines $H_1 H_2$ and $I_1 I_2$. Revolving H_1 and I_1 back to the vertical line, the points H and I will be obtained and the distances moved by the follower during the three equal time periods on the upstroke will be $A H$, $H I$ and $I V$ respectively.

306. The path of contact between the cam wiper and the toe is shown by the curved dash line $A V_3$, Fig. 133. Points on this curve, such as at I_3 , are obtained by revolving the point of tangency I_2 around until it meets the horizontal line through I .

307. OTHER CONSIDERATIONS RELATING TO VARIABLE ANGULAR VELOCITY DRIVE, brought out in this problem (Problem No. 29) are that the follower toe takes a longer time for the down-stroke as shown by the length of arc $L D$ as compared with $L B$, Fig. 133. This could be rectified and both times made the same, if desired, by placing the center O of the cam so that the points B_1 and L_1 would be on the horizontal line through C . This would only be possible with certain limited combinations of lengths of crank arms and rods, and in any event the intermediate velocities of the follower would be different on the up- and down-strokes. If it were desired to know the distances moved by the follower during three equal periods on the down-stroke the equally spaced points M and N , Fig. 133, would be obtained and used in exactly the same way as explained for G and K in paragraph 305.

The point F is the outward dead center position of the driving crank pin and is found by continuing the straight line through F_1 and C to F . When the driving crank pin is at F , the cam surface is in the position shown by the dash line $A_3 W_5$ and A_1 is at A . While B is moving from D to F , A_1 is moving to A and the follower toe is at rest, being supported by the cylindrical surface $A A_1$ rubbing against it, or it may be supported by a resting block indicated at $S Y$.

It is sometimes thought that this toe-and-wiper cam is practically free from rubbing action especially where the length of the toe surface equals approximately that of the wiper, but it will be seen from the velocity diagram shown just above the cam and described in paragraphs 317 and 318, that there may be considerable rubbing.

Fig. 138.—(Duplicate) Problem 33. DIAGRAM OF SLIDING VELOCITY

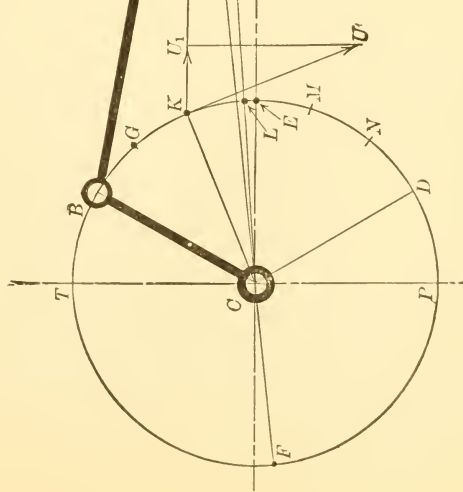
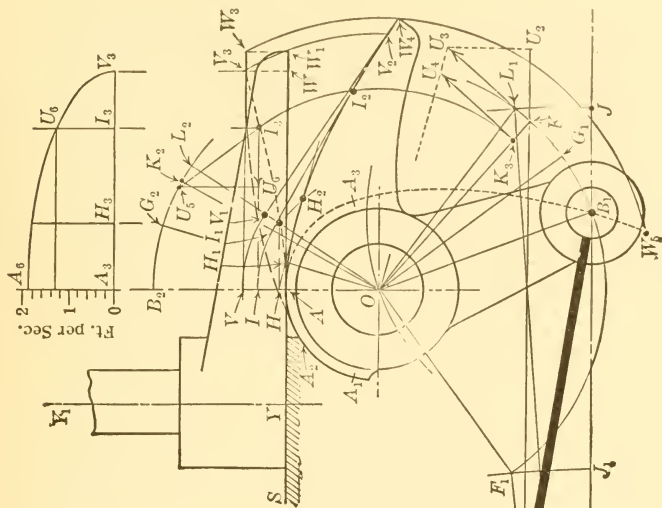

Fig. 133.—(Duplicate) Problem 29. OSCILLATING CAM WITH VARIABLE ANGULAR VELOCITY

There must be some sliding in all flat-toe followers where the acting surface is perpendicular to the right-line motion of the follower, as it is in Fig. 133.

308. EXERCISE PROBLEM 29a. OSCILLATING CAM HAVING VARIABLE ANGULAR VELOCITY. Required an oscillating wiper cam, operated by a crank and connecting-rod from a main shaft, to raise and lower a straight-toe follower through a distance of three units while the crank shaft turns through 150° . Find, also, the distances that will be traversed by the follower toe during equal intervals of time on the up-stroke. Assume the following dimensions: Main crank radius, 5 units; connecting-rod length, 30 units; cam-arm radius, 7 units; shortest cam surface radius, 4 units.

309. TOE-AND-WIPER CAM WHERE TOE IS CURVED. In the toe-and-wiper cam explained in the paragraphs immediately preceding, a flat surface toe YW , Fig. 133 was used. A curved toe such as is shown at AW , Fig. 134 may be used as illustrated in the following problem.

310. PROBLEM 30. REQUIRED A WIPER CAM TO OPERATE A CURVED-TOE FOLLOWER which shall move:

(a) Up 4 units on the elliptical base curve where the ratio of axes is 2 to 4, while the cam turns 45° in a counter-clockwise direction with uniform angular velocity.

(b) Down 4 units on the same base curve, while the cam turns 45° in a clockwise direction with uniform angular velocity.

311. While the follower toe may have the form of any smooth curve which is convex to the cam wiper, an arc of a circle will be assumed because of the ease in drawing. The general principles of construction are the same for this problem as in Problem 12. The shortest radius OA of the wiper cam, Fig. 134 is assumed. The form of the curved toe is the circular arc AW , with its center at A_1 . It is convenient in such a problem as this to work with the center points of the follower arc, and, therefore, the 4 units of travel are laid off first at A_1V_1 instead of AV . The semi-ellipse in which $I_1U_1 : I_1V_1 :: 2 : 4$ is drawn and the perimeter divided into equal parts at J', U_1, H' . Only four construction points are used in this problem in order to secure as much simplicity as possible in the illustration. In practice, more construction points should be used. The four construction centers at H_1, I_1, J_1, V_1 , are revolved to their corresponding positions relatively to the cam at H_2, I_2, J_2 , and V_2 and

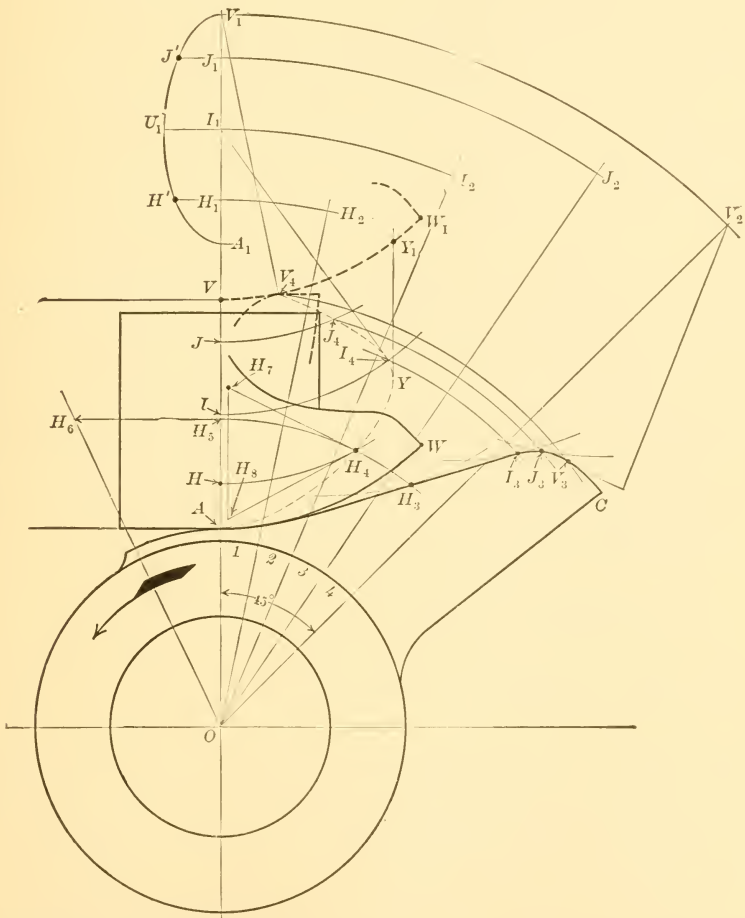
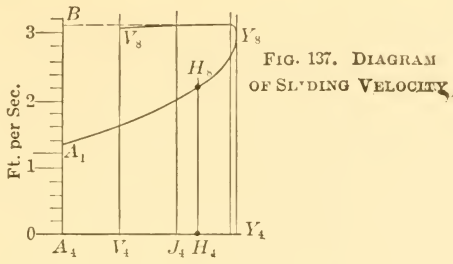

FIG. 134.—PROBLEM 30. OSCILLATING CAM WITH CURVED-TOE FOLLOWER

the toe-arcs drawn as shown at H_3 , I_3 , J_3 , and V_3 . The wiper cam curve $A C$ is then drawn tangent to these arcs and the tangent points revolved back to their actual positions at H_4 , I_4 , J_4 , and V_4 , thus obtaining the locus of contact between the wiper and toe. This locus is shown by the dashline curve $A H_4 V_4$. The necessary length $V Y_1$ of the follower arc is also obtained by projecting the extreme point Y on the locus to Y_1 and adding an arbitrary distance such as $Y_1 W_1$ to avoid wear at the tip end.

312. If an irregular curve had been used for the form of the toe instead of a circular arc it would have been necessary to construct a template of the desired form of the toe and to move it out radially the desired distances on each of the radial construction lines $O H_2$, $O I_2$. . . , keeping the template always in the same relative position with each of the radial lines. At each of the four adjustments of the template, arcs would have been drawn against the template edge and the work then continued as described in the preceding paragraph.

313. The pressure angles in the toe-and-wiper cams are quite different for flat and curved toes. In Fig. 133 the line of pressure is always parallel to the axis $Y Y_1$, of the follower rod, as illustrated by the vertical line at $W V_3$; and the maximum leverage with which it acts on the bearings is $Y W$. With the curved-toe wiper the line of pressure is an inclined line and the pressure angle at the top of the stroke is $V V_1 V_4$, Fig. 134, and when the follower is half way up the pressure angle is $I I_1 I_4$.

314. EXERCISE PROBLEM 30a. REQUIRED A WIPER CAM TO OPERATE A CURVED-TOE follower which shall move:

(a) Up 3 units with uniform velocity while the cam turns 60° in a counter-clockwise direction with uniform angular velocity.

(b) Down 3 units with uniform velocity while the cam turns 60° in a clockwise direction with uniform angular velocity.

315. RATE OF SLIDING OF CAMS ON FOLLOWER SURFACE. The rubbing velocity of cams which are in sliding contact with the follower, may be readily determined by constructing simple velocity diagrams at each of the construction points, as explained in the following paragraphs.

316. PROBLEM 31. RATE OF SLIDING BETWEEN CAM AND FLAT FOLLOWER SURFACES. Find the curve of rubbing velocity between surfaces in a toe-and-wiper cam mechanism where the follower toe is

a flat surface. Assume that the wiper oscillates with uniform angular velocity.

317. In Fig. 135 let the angle $I_4 O I_5$ represent the uniform angular velocity of the wiper cam. Then the point I_2 on the cam will have the linear velocity $I_4 I_5$. Laying this value off at $I_3 I_6$, where I_2

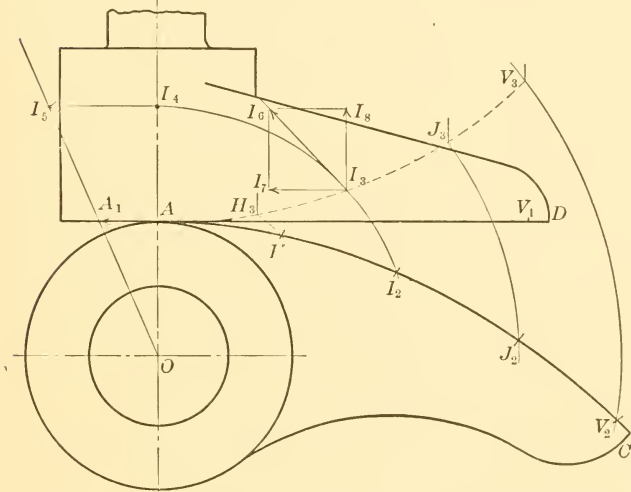
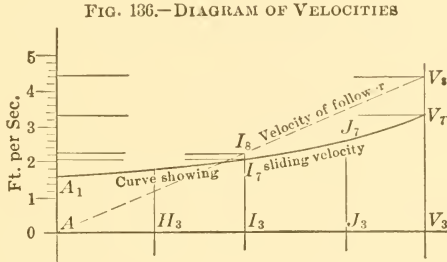

FIG. 135.—PROBLEM 31.—SLIDING IN TOE-AND-WIPER CAMS

comes into action, and taking the component $I_3 I_7$, the actual rubbing velocity is obtained. This may be transferred to $I_3 I_7$ in Fig. 136 and, finding other ordinates, the complete sliding-velocity curve $A_1 V_7$ is obtained. The ordinate $A A_1$ is quickly obtained, for it is obviously equal to the linear velocity line $A A_1$ in Fig. 135. In Fig. 135 the detail construction for obtaining the velocity of the follower is shown only at one point, I_3 , the construction at the other

points being the same. Also all lines pertaining to the construction of the cam are omitted, as they are fully given in Fig. 52.

318. THE ACTUAL RATE OF SLIDING IN FEET PER SECOND may be readily found at any position by means of the velocity diagram in Fig. 136. For example, if the cam shaft O , Fig. 135, is considered to oscillate back and forth through 45° , 100 times per minute with uniform angular velocity, and if the radius $O I_4$ is 14 inches, the line $I_4 I_5$ will be drawn to represent a velocity of

$$\frac{2 \times 14 \times 3.14 \times 2 \times 100}{8 \times 12 \times 60} = 3.04 \text{ feet per second.}$$

This value, laid off as the resultant velocity at I_3 , gives a component or sliding velocity $I_3 I_7$ which is laid off at $I_3 I_7$ in Fig. 136. Other ordinates, found in the same way, will give the curve $A_1 V_7$, showing the sliding velocity between cam and toe in feet per second. The minimum rate of sliding will be $A A_1$ shown in both Figs. 135 and 136, and will be 1.6 measured on the same scale that was used to lay out $I_4 I_5$.

319. THE VELOCITY OF THE FOLLOWER, in feet per second, may also be readily found by simply taking the vertical component $I_3 I_8$, Fig. 135, and laying it off at $I_3 I_8$ in Fig. 136. Taking the vertical components at other points the line $A V_8$, showing the linear velocity of the follower will be obtained. The line $A V_8$ is a straight line in this problem because this cam illustration was taken so that the follower would have uniformly increasing velocity. In general, where the cam curve $A V_2$ in Fig. 135 is assumed, the line $A V_8$ in Fig. 136 will not be straight.

320. EXERCISE PROBLEM 31a. SLIDING VELOCITY BETWEEN CAM AND FOLLOWER. Assume a flat-toe follower with a rise of 3 inches and a cam wiper of minimum radius of 4 inches which oscillates with uniform angular velocity through 150 cycles per minute. Construct the toe-and-wiper surfaces and find the curve of sliding velocity between them in feet per second. Find also the curve of linear velocity of the follower toe and state the maximum velocity in feet per second.

321. PROBLEM 32. SLIDING VELOCITY WITH CURVED TOE FOLLOWER. Find the curve of rubbing velocity between surfaces in a curved toe-and-wiper cam mechanism, assuming that the wiper oscillates with uniform angular velocity.

In curved-toe followers the general principle of obtaining the rubbing velocity is the same, although the detail of drawing the velocity diagram differs slightly. In Fig. 134 the linear velocity of the point H_3 on the cam is $H_5 H_6$ and this value is laid off at $H_4 H_7$. The direction of sliding at this phase must be that of the common tangent line to the two surfaces, and its length, which represents the velocity of sliding, is found by drawing the line $H_7 H_8$ parallel to the direction of motion of the point H_4 on the follower. The length of $H_4 H_8$ is thus found and is laid out as shown in Fig. 137, directly over H_4 of Fig. 134. Other lines representing the rubbing velocity are similarly found and laid out in Fig. 137, thus obtaining the rubbing velocity curve $A_1 H_8 V_8$.

322. In the case of the curved-toe follower it will be noted that that portion of the toe from V_4 to Y_1 , Fig. 134, will be traversed twice as often as the portion from V to V_4 , and in addition the rubbing velocity will be much greater. In the flat-toe follower, Fig. 135, the point of contact travels regularly forth and back the full distance on each stroke, but the wear as in the curved-toe follower will be irregular, due to the variable rubbing velocity, which in the case illustrated in Fig. 136 is a maximum at the tip end.

323. EXERCISE PROBLEM 32a. SLIDING VELOCITY WITH CURVED-TOE FOLLOWER. Find the curve of rubbing velocity between cam surfaces in Problem 30a, assuming that the wiper cam oscillates through a cycle 90 times per minute. Show scale for curve.

324. PROBLEM 33. SLIDING VELOCITY WHERE CAM HAS VARIABLE ANGULAR VELOCITY. Find the curve of rubbing velocity between surfaces in a flat toe-and-wiper cam construction, assuming that the wiper cam oscillates with a variable angular velocity.

325. When an oscillating cam has variable angular velocity, as in Fig. 133, the extent of the sliding action between cam and follower may be found as in the present example. In Fig. 133, the length of crank represented by $C E$ is 4 inches and the crank is assumed to be turning 120 revolutions per minute. The velocity of the crank pin will then be $\frac{2 \times 3.14 \times 4 \times 120}{12 \times 60} = 4.19$ feet per second.

326. The velocity just obtained is represented by the line $K U$, Fig. 133, laid off to any convenient scale. Its component $K U_1$ along the rod is found by dropping from U a perpendicular to the connecting-rod position $K K_1$. The component $K U_1$ is then transferred to the other end of the rod at $K_1 U_2$. This component gives a

resultant linear velocity of $K_1 U_3$ to the cam crank pin at the phase K_1 . At the radial distance $O K_3$, which is equal to the radii $O I_2$, and $O I_3$ the linear velocity will be $K_3 U_4$ and this transferred to I_3 will give $I_3 U_5$ as the resultant linear velocity of I_2 when it becomes the driving point. The line $I_3 U_6$ is the component in the direction in which sliding must take place and this is laid off at $I_3 U_6$ in Fig. 138. If $K U$ represents 4.19 feet per second, $I_3 U_6$, will represent 1.30 feet per second to the same scale and the maximum velocity of sliding, which is represented at $A_3 A_6$, will be 1.87 feet per second.

327. EXERCISE PROBLEM 33a. SLIDING VELOCITY WHERE CAM HAS VARIABLE ANGULAR VELOCITY. Assume crank $C E$, in Fig. 133, to be 5 units long and turning at rate of 100 revolutions per minute; also, take the angle $B C D = 150^\circ$ symmetrical about $C E$, the connecting rod $B B_1 = 30$ units, the cam arm $O B_1 = 7$ units, the minimum cam radius $O A = 4$ units and the cam lift 3 units. Construct the cam and follower and draw the curve of sliding velocity to scale.

328. ELIMINATION OF SLIDING FRICTION WHERE FLAT OR CURVED SURFACE FOLLOWERS ARE USED. The ordinary toe-and-wiper cam mechanism operates with more or less sliding action as shown in the preceding paragraphs. Cams resembling the toe-and-wiper type may be constructed so as to eliminate all sliding friction by using special curves and lines for the wiper and toe surfaces as will be explained in succeeding paragraphs. Fig. 139 shows a straight surface toe moving up and down in a straight line while in Fig. 146 a similarly moving toe has a curved working surface. In both there is pure rolling action. Likewise, in Figs. 142 and 145 the working surface of the follower arm is straight in one case and curved in the other, yet in both cases there is pure rolling action. In all cases of pure rolling action on flat or curved surfaces it is impossible to assign various intermediate velocities to the follower as part of the data of the problem.

329. THE PRINCIPLE OF PURE ROLLING ACTION BETWEEN CAM SURFACES. It is a fundamental principle of pure rolling action between two rotating surfaces that the point of contact between them must always be on the line of centers. This is illustrated in Fig. 141 where the point of contact, C , is on the line of centers $A B$, and where the contact point between the curves $C D$ and $C E$ will always be on the line of centers. This principle also applies in Fig. 139, where the follower toe $B D$ is moving up and down in a straight line and where it must be considered that the toe is turning about a point on the line

$A B F$ at an infinite distance. Then $A F$ becomes the line of centers and the point of contact between $B C$ and $B D$ will always be on the line $B F$.

330. WELL-KNOWN CURVES THAT LEND THEMSELVES READILY TO PURE ROLLING ACTION in cam work are the logarithmic spiral and the ellipse. Examples of these will be given in following paragraphs, where the solutions are entirely graphical and comparatively simple. The parabola and the hyperbola may also be readily used for rolling cam surfaces. Any line or curve that may readily be expressed by a mathematical equation may also be taken as one surface and the equation for the other curve that will work with it in pure rolling action may be derived. An example of this is given in paragraph 346. The use of the logarithmic curve for pure rolling action in the toe-and-wiper type of construction where the follower toe has a straight-edge working surface and moves in a straight line is given in the paragraphs immediately following.

331. PROBLEM 34. PURE ROLLING WITH FLAT SURFACE FOLLOWER. Required an oscillating logarithmic cam arm that will give a straight-line reciprocating motion to a flat-surface follower arm, with pure rolling action:

- (a) The follower to move up $4\frac{1}{4}$ units, while the cam turns 30° .
- (b) The pressure angle to be 20° .

332. This problem is illustrated in Fig. 139 where the flat-surface toe $B D$ is moved from the solid-line position to the dash-line position while the cam $A B C$ swings through the angle $C A F$. The method of constructing the problem is as follows:

Draw the horizontal line $A F$, Fig. 139, and from any point B draw a line $B D$ making an angle with $B F$ equal to the assigned pressure angle. Continue $B D$ until the vertical distance between it and $B F$ is equal to the assigned lift of the follower, $4\frac{1}{4}$ units in this problem as measured at $D F$. Mark the point F . Assume the distance $A B$ sufficient to allow for the cam shaft and cam hub. $A B$ is taken as 4 units in this problem, and $A F$ is found upon measuring, to be 16 units. Substitute these values in the following general equation:

$$\theta = \frac{180^\circ \times \tan \alpha}{\pi \times .434} \log \frac{R}{r} = \frac{180^\circ \times .364}{3.14 \times .434} \times .602 = 28.8^\circ$$

in which $r = 4$, $R = 16$, $\alpha = 20^\circ$, and in which θ gives the angle whose limiting radial line $A C$ is equal in length to $A F$:

in successive computations and laying off the resulting angles which are found to be 22.9° , 19.1° , 14.4° , and 8.45° respectively.

335. The pressure angle between the two cam surfaces will be a constant and equal to α . The smaller the pressure angle, the longer will be the toe of the follower for a given lift. As a corollary to the conditions of pure rolling action it follows that the developed length of the logarithmic arc BC must be equal to the length of the straight line BD . The stem EG of the follower toe may, in general, be taken with its center line midway between B and F .

336. EXERCISE PROBLEM 34a. PURE ROLLING WITH FLAT SURFACE FOLLOWER. Required an oscillating cam arm that will give a straight-line reciprocating motion to a flat-surface follower arm, with a pure rolling action:

- (a) The follower to move up 1 unit while the cam arm turns 30° .
- (b) The pressure angle to be 15° .

337. THE USE OF THE LOGARITHMIC CURVE FOR PURE ROLLING ACTION between two rolling cam arms, where both arms oscillate, is shown in the paragraphs immediately following. Before taking up a definite problem it is necessary to consider, in order to obtain a satisfactory understanding, some of the properties peculiar to the logarithmic curve. These properties are:

First. That in a series of equally spaced radial lines drawn from the pole to the logarithmic curve, the length of any one line is a mean proportional of the lines on either side. To illustrate, the curve GH , Fig. 140, is a logarithmic curve, the radial lines AG , AK , AL , and AH are spaced by equal angles and $AK : AL :: AL : AH$, or, $AL = \sqrt{AK \times AH}$. The spacing angle may be of any size.

Second. That the difference in length between any two radial lines drawn from the pole to the curve will be the same no matter where those radial lines are taken, providing they intercept equal lengths of arc. To illustrate the difference $C_1A - EA$, Fig. 140, is equal to $DA - CA$ for the reason that the arcs CD and EC_1 , were made equal in developed length.

Third. That a tangent and a radial line at any point on a logarithmic curve form the same size of angle, no matter where the point is taken. To illustrate, the angle between the tangent QC and the radial line AC , Fig. 140, equals the angle between Q_1H and AH .

338. PROBLEM 35. PURE ROLLING WITH LOGARITHMIC CURVED CAM ARMS. Construct a pair of pure rolling oscillating cam arms

with logarithmic curved surfaces, the driver swinging through 21° and the follower arm through one-half of that angle.

339. The first step in the solution of Problem 35 consists in drawing a logarithmic curve of any desired curvature by assuming any convenient angle such as 60° as shown at $K A H$ in Fig. 140 and any two lengths of lines as shown at $A K$ and $A H$. K and H will then

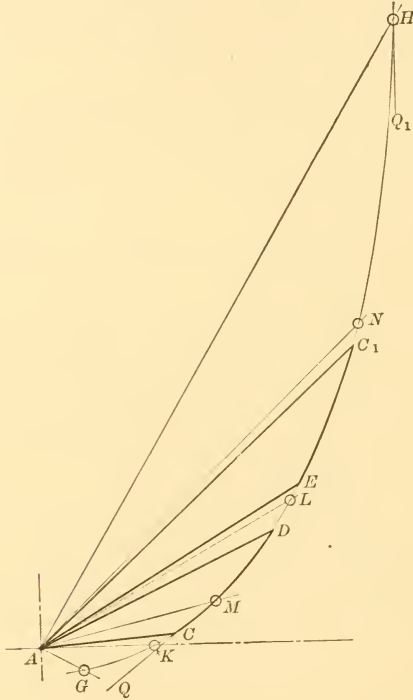

FIG. 140.—PROBLEM 35, BASIC LOGARITHMIC CURVE FOR OSCILLATING CAM ARMS HAVING PURE ROLLING ACTION

be points on the logarithmic curve. To find an intermediate point, bisect the angle $K A H$ as at $A L$ and make $A L$ a mean proportional between $A K$ and $A H$ in accordance with the first general principle of paragraph 337. To find a point to the left of K , make the angle $K A G$ equal to angle $L A K$; then $A K$ becomes the mean proportional, and $A G : A K :: A K : A L$, or $A G = \frac{A K^2}{A L}$.

340. Having constructed the general logarithmic curve as above, lay off an angle of 21° with the vertex at A , Fig. 140 and with the

sides at $A C$ and $A D$, or, the sides may be in any other position, according to the length desired for the cam arm. Make a tracing of of the angle $C A D$ and of the arc $C D$ and reproduce it at $C A D$ in Fig. 141. Also draw the body outlines of the cam arm, and the driver is then completed. To find the follower, step off the arc $C D$, Fig. 140, into four or six steps with the dividers and restep the distance $C D$ off on another part of the logarithmic curve where the newly placed arc, equal to $C D$, will be subtended by an angle of $10\frac{1}{2}^\circ$ as specified in the data. The new position for the length of the arc must be found by trial, and in this problem it is at $E C_1$ in Fig. 140 where the arc $E C_1$ equals $C D$ in length and the angle $E A C_1$ equals one-half of $C A D$. The angle $E A C_1$ and the arc $E C_1$ are now traced on tracing cloth and redrawn at $C B E$ in Fig. 141. Upon drawing the outlines for the arm the follower is completed.

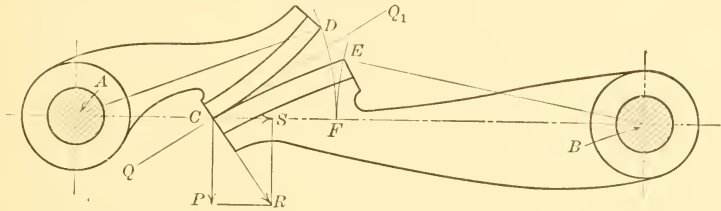

FIG. 141.—SWINGING CAM ARMS WITH LOGARITHMIC SURFACES IN PURE ROLLING ACTION

341. THE ANGULAR MOTION OF EACH CAM depends on the positions on the logarithmic curve at which the equal arcs are taken. Had it been desired to swing the shaft B through a larger angle, the logarithmic arc $E C_1$, Fig. 140, would have been taken lower down. When $E C_1$ coincides in position with $C D$, the arm $C B$, Fig. 141, will swing through the same angle as the arm $C A$ and both arms will be of the same length and identical in every way.

342. TANGENCY OF LOGARITHMIC CAM SURFACES. The fact that the two rolling cam curves $C D$ and $C E$, Fig. 141, are tangent at C follows from the third principle laid down in paragraph 337, which points out that the tangents at C and C_1 , Fig. 140, make the same angles with $C A$ and $C_1 A$ respectively. Since C and C_1 come together on the same straight line $A B$ in Fig. 141, the angle $B C Q_1$ in that figure will equal the angle $A C Q$.

343. REGULATION OF PRESSURE ANGLE WHERE LOGARITHMIC ROLLING CAMS ARE USED. Logarithmic curves of varying sizes, or expansion, may be used for rolling cam surfaces, but in general, the

best results will be obtained by using curves having a large expansion. The expansion may be measured specifically by noting the rate of increase in the length of the successive radial lines which are drawn at equal angles with each other. The greater the expansion of the logarithmic curve, the smaller will be the pressure angle, or radial pressure on the bearings of the cam. This is shown in Fig. 141, where PCR is the pressure angle and CS is the radial pressure on the bearings. If curve CD had a greater expansion, its normal CR would fall nearer CP and the pressure angle would be smaller.

344. EXERCISE PROBLEM 35a. PURE ROLLING LOGARITHMIC CAM ARMS. Construct a pair of rolling oscillating cam arms with curved surfaces, the driver swinging through an angle of 30° , and the follower through 20° .

345. DERIVED CURVE FOR ROLLING CAM ARMS. Any line or curve that is expressed by a mathematical equation may be taken as the form of an oscillating cam arm, and the equation for another curve that will work with it in pure rolling action may be derived. In the paragraphs immediately following, a cam arm with a straight surface is assumed and the curve that will work with it is derived. The derivation of the curve involves the use of calculus, but the results are comparatively easy to apply practically.

346. PROBLEM 36. THE USE OF A DERIVED CURVE FOR ROLLING CAMS. Given a straight-edge oscillating follower arm. Required a curved oscillating arm that will work with it with pure rolling action.

347. In solving the above problem the following notation, illustrated in Fig. 142, will be used: a = angle between the line of centers of the oscillating arms and the line of the straight follower surface for the phase in which this line, when extended, passes through the axis of the driver shaft. The angle a is a constant.

b = angle turned through by the straight follower arm, at any phase, measured from the horizontal position.

c = construction angle for the curved follower arm.

L = distance between centers.

R = working radius of follower arm at any phase.

S = working radius of driver arm at phase corresponding to R .

Then,
$$\sin a = \frac{BI}{AB} = \frac{R_1}{L}; \quad \dots \dots \dots (1)$$

$$R = \frac{BC}{\sin BDC} = \frac{R_1}{\sin b}; \quad \dots \dots \dots (2)$$

$$S = L - R; \dots \dots \dots (3)$$

$$C = \frac{180^\circ \tan a}{\pi \times 0.4343} \log \frac{\cos \frac{1}{2}(b + a)}{\sin \frac{1}{2}(b - a)} \dots \dots (4)$$

Assuming $L = 24$, and $R_1 = 4$, we have from equation (1),

$$\sin a = \frac{4}{24} = 0.1668, \text{ and from a table of sines, } a = 9\frac{3}{4}^\circ.$$

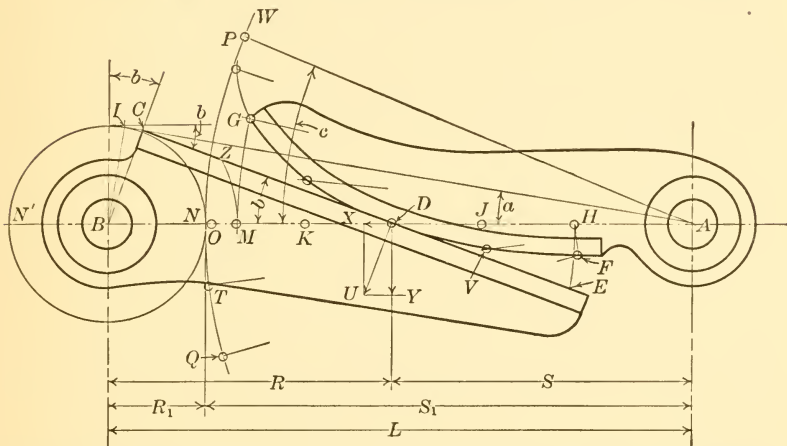

FIG. 142.—PROBLEM 36, SWINGING CAM ARMS WITH DERIVED SURFACES IN PURE ROLLING ACTION

Then, from equations (2) and (3), for

$$b = 12^\circ, R = \frac{4}{.208} = 19.22 \text{ and } S = 24 - 19.22 = 4.78$$

$$b = 15^\circ, R = \frac{4}{.2588} = 15.45 \text{ " } S = 24 - 15.45 = 8.55$$

$$b = 20^\circ, R = \frac{4}{.342} = 11.70 \text{ " } S = 24 - 11.70 = 12.30$$

Similarly, for $b = 30^\circ, R = 8.00$; for $b = 50^\circ, R = 5.23$; for $b = 70^\circ, R = 4.26$; and for $b = 90^\circ, R = 4 = R_1$.

From equation (4), for

$$\begin{aligned} b = 12^\circ, c &= \frac{180^\circ \times .1718}{3.1416 \times .4343} \log \frac{\cos \frac{1}{2}(12^\circ + 9\frac{3}{4}^\circ)}{\sin \frac{1}{2}(12^\circ - 9\frac{3}{4}^\circ)}; \\ &= 22.67 \log \frac{.982}{.0196} = 22.67 \times 1.70 = 38.6^\circ; \end{aligned}$$

$$b = 15^\circ, c = 22.67 \log \frac{.9767}{.0457} = 22.67 \times 1.32 = 30^\circ;$$

$$b = 20^\circ, c = 22.67 \log \frac{.9665}{.0893} = 22.67 \times 1.033 = 22.8^\circ.$$

Similarly for $b = 30^\circ, c = 16.5^\circ$; for $b = 50^\circ, c = 9.1^\circ$; for $b = 70^\circ, c = 4.2^\circ$; and for $b = 90^\circ, c = 0^\circ$.

348. Plotting the above values of R in Fig. 142, $BH = 19.22$ and $AH = 4.78$; $BJ = 15.45$; and $BD = 11.70$, etc. A test of the accuracy of the work thus far may now be made by drawing a line from H tangent to the circle having R_1 for a radius and noting if it makes an angle of 12° with the line of centers. Likewise a line from

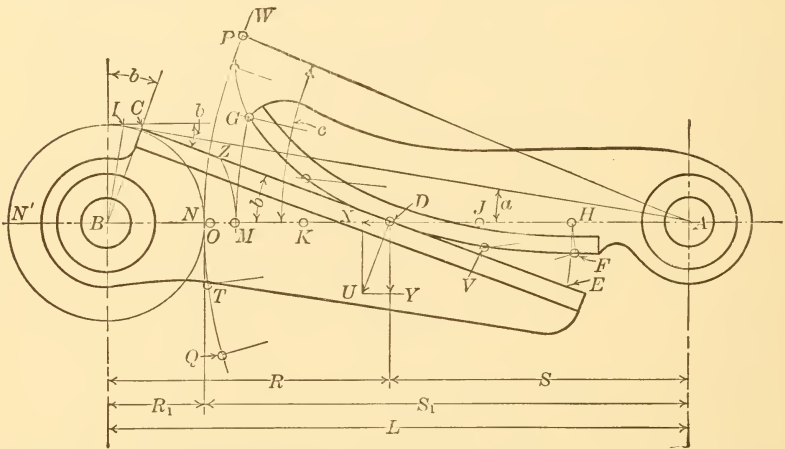

FIG. 142.—(Duplicate) PROBLEM 36, SWINGING CAM ARMS WITH DERIVED SURFACES IN PURE ROLLING ACTION

D tangent to this same circle should make an angle of 20° with DB , etc.

Again, plot the values of c , starting with any phase in which it is desired to show the cams. In this case the phase illustrated is for the straight cam at an angle of 20° . Lay off the angle $DAP = 22.8^\circ$. Then, starting with AP as a datum line lay off the values of c as found above, making the arc $PQ = 38.6^\circ$, arc $PT = 30^\circ$, etc.

Finally on each of the lines AQ, AT , etc., lay off the corresponding values of S . These values have already been found to be 4.78 and 8.55 respectively, etc. Thus the points $F, V, D \dots P$ on the follower cam curve are obtained.

349. ROLLING CAMS USEFUL FOR STARTING SHAFTS GRADUALLY. The curve FDP is tangent to the circular arc having AP for a radius. This suggests an interesting and perhaps useful mechanical addition in that gear teeth might be cut on GPW as a pitch line, and also on ZCN' as a pitch line, thus permitting an oscillating shaft A to give a certain number of complete revolutions in opposite directions to the shaft B . In starting each cycle, the shaft B would accelerate gradually, and it would come to rest gently at the end of its cycle. The rate at which the motion of the shaft B would accelerate at starting is indicated by the ratios $\frac{HA}{HB}$ to $\frac{NA}{NB}$. (Giving the actual values which these ratios have in this problem, it is found that the acceleration of B increases from $\frac{4.78}{19.22}$ to $\frac{20}{4}$ or from about $\frac{1}{4}$ of the angular velocity to five times that of the shaft A .)

350. REGULATION OF PRESSURE ANGLE WITH DERIVED ROLLING CURVE. Returning to Problem 36 and considering it only as a cam mechanism it will be noted that the angles taken for b in the computations become the pressure angles and show a measure of the radial thrust that goes into the bearings without producing any useful rotative effort. For example, in Fig. 142, the cams are in contact at D and the normal pressure is represented by DU . The component pressure DX goes to the bearings and DY is useful in turning the shaft B . The pressure angle UDY is 20° . When G reaches M , it will be in contact with Z and the pressure angle will be 50° .

351. EXERCISE PROBLEM 36a. THE USE OF A DERIVED CURVE FOR ROLLING CAMS. Given a straight-edge oscillating follower arm. Required a curved oscillating arm that will work with it in pure rolling action. Let distance between centers of oscillating arms be 30 inches and the maximum theoretical length of the curved toe 20 inches.

352. ELLIPTICAL ARCS FOR PURE ROLLING CAMS. Pure rolling oscillating cam arms having arcs of ellipses for their working surfaces, may also be used. In constructing these cams, use is made of the characteristic of the ellipse that the sum of the two lines drawn from any point on the perimeter to the foci will be constant and will be equal to the length of the major axis. Briefly then, it is only necessary to take two identical ellipses and center them on one pair of their foci at a distance apart equal to their major axis. Such a pair of ellipses, illustrated at AC and BD in Fig. 143, will then

turn through 360° respectively and will be in pure rolling contact all the time. Oscillating rolling cam arms may be obtained from the ellipses by simply taking equal and symmetrically placed arcs from each as shown at EF and GH , Fig. 143. The following problem will illustrate the method of construction.

353. PROBLEM 37. PURE ROLLING ELLIPTICAL CAM ARCS, ANGLES OF ACTION EQUAL. Construct a pair of oscillating rolling cam arms whose working surfaces are arcs of ellipses. Take the distance between centers as 24 units, make the angle of action of the driver and follower shafts the same, and find the pressure angle at any point.

354. In constructing Problem 37, lay down the assigned distances between centers, 24 units, as at A and B in Fig. 143. These points will lie at the fixed focus of each ellipse. Take any point, such as K , on the line of centers between A and B . The nearer K is taken to one of the foci the smaller will be the pressure angles between the rolling cam surfaces according to this construction, other data being the same. With K as a center and KB as a radius draw an arc BL of any desired length thus obtaining the angle BKL which may be any value. The smaller it is taken the flatter will be the resulting working surface GH of the cam and the smaller will be the pressure angles. Had K been taken midway between A and B , and had the angle BKL been made 90° , a limiting case would have resulted in which the ellipses from which the cam arms are taken would have had a minimum eccentricity and the cam arms would have had the largest angle of action, but the pressure angles would have been larger. With K as a center draw the arc AI making angle AKI equal to BKL . Then L and I are the free foci of the basic ellipses.

355. TO FIND THE MAJOR AND MINOR AXES OF THE ELLIPSES take L and A , Fig. 143, as centers and one-half of AB as a radius and draw short arcs intersecting at M and at N as indicated at M . Also use B and I as centers in the same way, thus obtaining O and P . M and N will then be the extremities of the minor axis of one ellipse, and O and P the extremities of the other. From J , which is midway between A and L , lay off distances JQ and JC equal also to one-half of AB . Q and C are then the extremities of the major axis of one ellipse, and similarly D and R are the extremities of the other ellipse.

356. TO FIND POINTS OF THE ELLIPSE take a piece of paper, or a thin card, having a perfectly straight edge as indicated by the dash

of arcs symmetrical about the extremity of the minor axis are taken from each ellipse. Thus NE equals NF , Fig. 143, and OG equals OH equals NF . The angle of action for each cam is then equal to EAF . This angle may be made larger or smaller by increasing or decreasing the arcs NF and NE . These arcs, however, should not approach too closely to the extremities of the major axis, for the pressure angle then increases rapidly, as, for example, when the contact point moves from F toward Q .

358. PRESSURE ANGLE IN ROLLING ELLIPTICAL CAM ARMS. The pressure angle is the angle between the perpendicular to the radial line at the point of contact and the normal to the curve at that point. It varies at different phases and is a minimum when the extremities of the minor axes are in contact, that is when N and O , Fig. 143, come in contact at X . Consequently the angle SOZ is the pressure angle when O is in action. The line OZ is perpendicular to the radial line BO , and the line OS is normal to the curve at O . At K the angle WKY is the pressure angle. The normal to the ellipse at any point, such as KY , may be readily found by making use of the property of the ellipse that the normal to the curve at any point is the bisector of the angle formed by the focal lines from that point. For example KB and KI are focal lines from K , and KY bisects the angle BKI .

359. EXERCISE PROBLEM 37a. PURE ROLLING ELLIPTICAL CAM ARMS, ANGLES OF ACTION EQUAL. Construct a pair of oscillating rolling cam arms whose working surfaces are arcs of ellipses. Take the distance between centers as 20 units, make the angle of action of each shaft the same, and find the pressure angle at the extremity of the angle of action.

360. PROBLEM 38. ELLIPTICAL ROLLING CAM ARCS, ANGLES OF ACTION UNEQUAL. Construct a pair of oscillating rolling cam arms whose working surfaces are composed of an arc of an ellipse. Take the distance between centers as 24 units, make the angle of action of the driver 2.9 times that of the follower and find the maximum pressure angle.

361. In the solution of this particular problem any ellipse may be used whose major axis is 24 units long. The shorter the minor axis is taken the less will be the pressure angle, and the smaller also will be the actual practical angles through which the cam arms will swing. In laying down the problem take QC , Fig. 144, equal 24 units, as the major axis of the ellipse. Bisect QC at X , and assume

$X M$ and $X N$ as the semi-minor axes. With M and N as centers and a radius equal to $Q X$ draw short arcs intersecting the major axis at A and at L . These points will be the foci of the ellipse. Construct the ellipse as directed in paragraphs 355 and 356. Select an arc of such length and position on the ellipse that it will subtend focal angles, i.e.

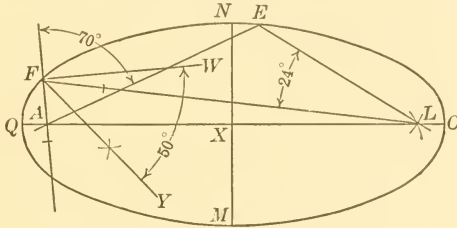

FIG. 144.—ANGLES OF ACTION FOR ELLIPTICAL CAM ARMS

angles whose vertices are at the foci, which are to each other as 1 is to 2.9. Such an arc is shown at $F E$ and it subtends an angle of 24° from the vertex at L and an angle of 70° from the vertex at A . The value of 2.9 given in the data is now provided for because 70 divided by 24 equals 2.9. The arc $F E$ is used for the form of the working surface of the two cam arms, as directed in the following paragraph.

362. To construct the cam arms for Problem 38, lay down the shaft centers by marking the points A and B , Fig. 145, 24 units apart. On a piece of tracing paper draw the arc $F E$ of Fig. 144 and mark the point A . Lay the tracing paper down in Fig. 145 with A of the

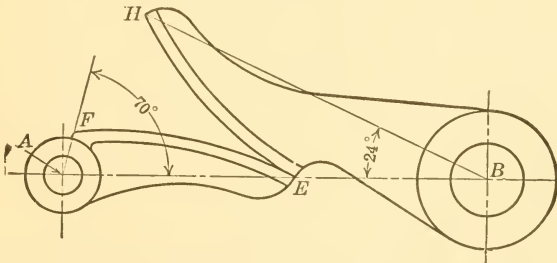

FIG. 145.—PROBLEM 38, PURE ROLLING ELLIPTICAL CAM ARMS, ANGLES OF ACTION UNEQUAL

tracing at A of the figure, and with E of the tracing on the center line $A B$. Redraw the traced curve in Fig. 145, giving $E F$. Again, on the tracing paper draw the curve $F E$ of Fig. 144 and mark the point L . Lay the tracing paper down in Fig. 145 with L of the

tracing at B , and E of tracing on the center line AB . Redraw the traced curve in Fig. 145, giving EH . EF and EH should be tangent at E if the work is correctly done. The forms of the arms and the hubs are now drawn, and the angles of 70° and 24° are indicated as shown in Fig. 145, thus giving a ratio of turning angles of 2.9 to 1 as required. The maximum pressure angle will be at the point on the working curve that is nearest to the extremity of the major axis of the original ellipse, and it will be equal to 50° as shown at WFY , Fig. 144.

363. EXERCISE PROBLEM 38a. ELLIPTICAL ROLLING CAM ARCS, ANGLES OF ACTION UNEQUAL. Construct a pair of oscillating rolling cam arms whose working surfaces are composed of an arc of an ellipse. Take the distance between centers as 18 units, make the angle of action of one shaft 2.2 times that of the other, and find the maximum pressure angle.

364. PURE ROLLING PARABOLIC CAM SURFACES FOR A RECIPROCATING MOTION. The parabola lends itself to pure rolling action in cam work, but it can be used only when either the driver or the follower has rectilinear motion, and then the rectilinear motion must be in a direction perpendicular to the line of axes of the two parabolas when they are in contact at their vertices.

365. PROBLEM 39. ROLLING PARABOLAS. Required a parabolic oscillating cam to give rectilinear motion to the follower with pure rolling action. Assume the length of path of contact, and find, (a) angle of action of driver, (b) range of motion of follower, and, (c) the maximum and minimum pressure angles.

366. CONSTRUCT A PARABOLA by making use of the property that a point on the curve is equidistant from the focus and the directrix. To do this, assume a point A , Fig. 146, as the focus of the parabola on the line XX as an axis. Assume the directrix YY at right angles to the axis and at any desired distance AB from the focus. The larger AB is taken the larger will be the oscillating cam for a given motion, and the smaller will be the pressure angles. The vertex of the parabola will be at J midway between A and B . A point on the curve may be found by assuming any radius, such as AD , and drawing a short arc as shown at D using A as a center; then laying off this radial distance on the axis starting from the directrix as at BD_1 , and drawing a perpendicular line D_1D until it meets the arc at D . The point D , thus obtained, will then be a point on the parabola and other points may be found in the same way and the

curve SJV drawn. Draw a radial line AK perpendicular to the desired direction of motion of the follower, which direction, in this problem, is CW . On this radial line, assume any distance RK as the path of action; then, arcs of circles through R and K having A for a center will limit the part GE of the parabolic curve which will form the driver cam surface. The entire oscillating cam GEA may now be drawn.

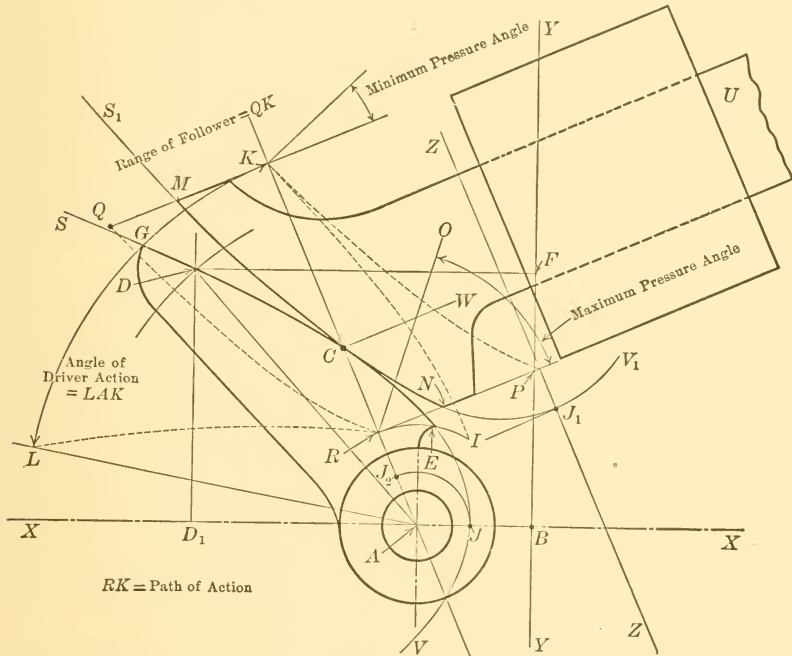

FIG. 146.—PROBLEM 39, PARABOLIC CAM SURFACES FOR PURE ROLLING RECIPROCATING MOTION

367. The surface MN on the follower arm, Fig. 146, will be identical with GE , already constructed, and may be readily found by drawing the lines SJV and XX on a piece of tracing cloth or paper, turning the paper on the reverse side, and then adjusting it, always keeping XX of the tracing parallel to AK , until the two curves come tangent as shown at C . The axis XX of the tracing will then be in the position ZZ . The follower cam surface and rod, MNU may now be drawn. The angle of action, range of action, and pressure angles may now be found as indicated in Fig. 146.

The two parabolic surfaces GE and MN , Fig. 146, will be in pure rolling action on the path KR , the driving cam turning about A , and the follower cam moving in a direction perpendicular to KA .

368. PURE ROLLING HYPERBOLIC CAM ARMS WHERE CENTERS ARE CLOSE TOGETHER. Two equal hyperbolas will give pure rolling action to two oscillating cam arms, the essential features of construction being that the hyperbolas should turn about one pair of foci as fixed centers and that the distance between these centers should equal the distance between the vertices of the hyperbolas. In Fig. 147 A and B are the foci of one hyperbola and CO and DU its two branches, while H and S are the foci of the other hyperbola and VW one of its branches.

369. PROBLEM 40. ROLLING HYPERBOLAS. As a problem illustrating the application of hyperbolas to rolling cam work, let it be required to construct two cam arms and shafts and determine the angle of action of each and the maximum and minimum pressure angles.

370. CONSTRUCT THE HYPERBOLAS by making use of the property that the distances from any point on the curve to two fixed points, called the foci, have a common difference. Therefore, assuming A and B as foci, Fig. 147, and C as a vertex, the common difference to be used throughout will be CB minus CA , equals CD . By assuming different distances between A and B , and A and C , different angles of action and different pressure angles will be obtained.

371. A point on the hyperbola, such as E , Fig. 147, is found by taking any radius such as BE and striking an arc with B as a center. Then with A as a center draw another short arc with a radius equal to BE minus CD . Where the second arc crosses the first will be a point on the curve as at E . Other points are found in the same way.

372. The center of one shaft will be located at the focus B if it is desired, for example, to show the cam surfaces in contact on the branch CO . Assuming E as the point of tangency of the two cam surfaces, the center of the other shaft, and consequently one focus of the other hyperbola, must be on the line EB , for the reason that in pure rolling action the point of contact must always be on the line of centers.

373. The second hyperbola must be placed with respect to the first so that the distances between the fixed foci and the free foci are equal to each other and to the distance between the vertices of the

hyperbola. Therefore, take the distance CD and lay it off at BH , also use it as a radius with A as a center to draw the short arc through S . With H as a center and AB as a radius draw another arc intersecting the first at S , thus determining the second focus, S , of the second hyperbola and its axis if it is desired. The tangent branch VW may now be independently constructed as explained for CO , or it may be traced from CO of which it is a duplicate.

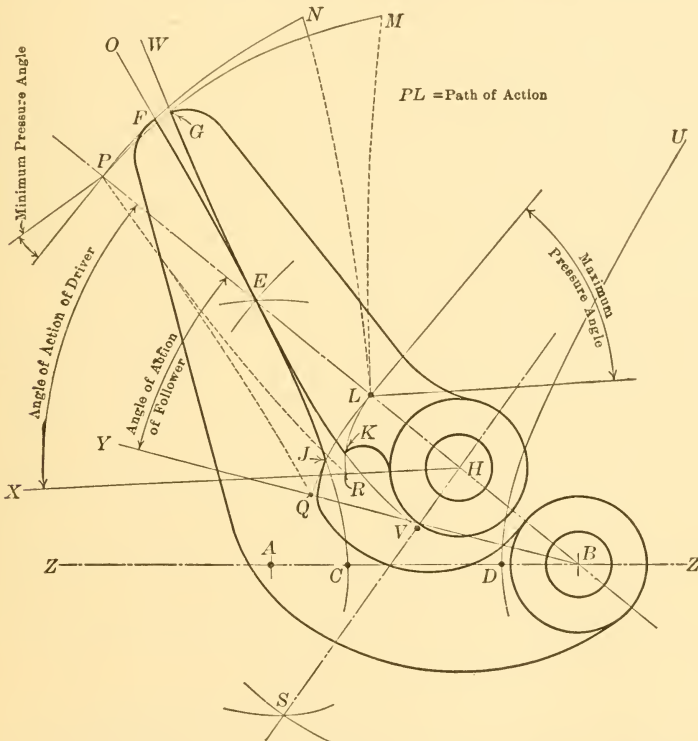

FIG. 147.—PROBLEM 40, HYPERBOLIC CAM SURFACES FOR SWINGING ARMS ON CLOSE CENTERS WITH PURE ROLLING ACTION

374. The path of action, assuming KG to be the driving cam surface, the angles of action for both cam shafts, and the maximum and minimum pressure angles may be obtained from a study of the illustration in Fig. 147.

Rolling hyperbolic cams differ from all others in that the path of action may lie entirely on one side of the centers of rotation, instead of between the centers as is the case with the logarithmic and ellip-

tical arms. The practical value of this is that it will permit driving action between two shafts that are very close together, as indicated by the shafts H and B in Fig. 147.

375. **DETAIL DRAWING OF CYLINDRICAL CAMS.** A simple practical method for constructing the surface guide line for the center of the cutting tool in cylindrical cams was explained in paragraph 127. A more elaborate method of construction giving a more precise mechanical action and a more complete drawing of the cam is now given.

376. **TO FIND THE TRUE MAXIMUM PRESSURE ANGLE OF A CYLINDRICAL CAM,** the pitch cylinder and not the surface cylinder should be drawn first. The pitch cylinder is shown at $B' W' H_3 \dots Q_3$, Fig. 148 and is drawn with a radius of 5.2, the data, excepting for pressure angle, being the same as for Problem 15. Briefly the data are: (a) Follower to move in a straight line 4 units to the right on the crank curve while the cam turns 120° ; (b) To move to left 4 units on crank curve while cam turns 120° ; (c) To dwell while cam turns 120° ; (d) the true maximum pressure angle to be 30° .

The pitch curve $Q_2 P_2 J$, etc., is then obtained and the normal $J G_1$ is drawn as in Problem 15. This normal will make an angle of 30° with $J D$ if the work is correctly done. This is the assigned maximum pressure angle and is at the *bottom of the pin*; the pressure angle $D J G$ at the surface of the cylinder will be less than 30° . In this problem the data and layout were such that the point J of maximum pressure angle could be readily made to fall on the front element of the cylinder and the angle $D J G_1$ thus shown in its true size. Where the data and layout are such as not to conveniently bring the pitch point on the front element of the cylinder, the pitch curve will have to be revolved if it is desired accurately to show the pressure angle in true size on the drawing.

377. **DRAWING OF GROOVE OUTLINES FOR CYLINDRICAL CAM.** If it is desired to draw the groove outlines of a cylindrical cam one of two methods may be used, (1) the approximate method, or, (2) a more exact method. The approximate method which is simpler and quicker and which gives good-appearing results where the slope of the groove does not exceed 30° is applied by laying off the points 1 and 2, Fig. 148, at equal distances on each side of H_2 on the surface pitch curve, these points representing the extremities of a diameter of the follower pin. Similarly the points 3-4, 5-6, etc., are obtained. A curve drawn through the points $S, 1, 3, 5$, etc., will represent one of the surface edges of the groove. The bottom lines of the groove

are found, for example, by projecting J_5 to J_4 and then laying out the diametral line $9-10$. A curve through 9 and other similarly

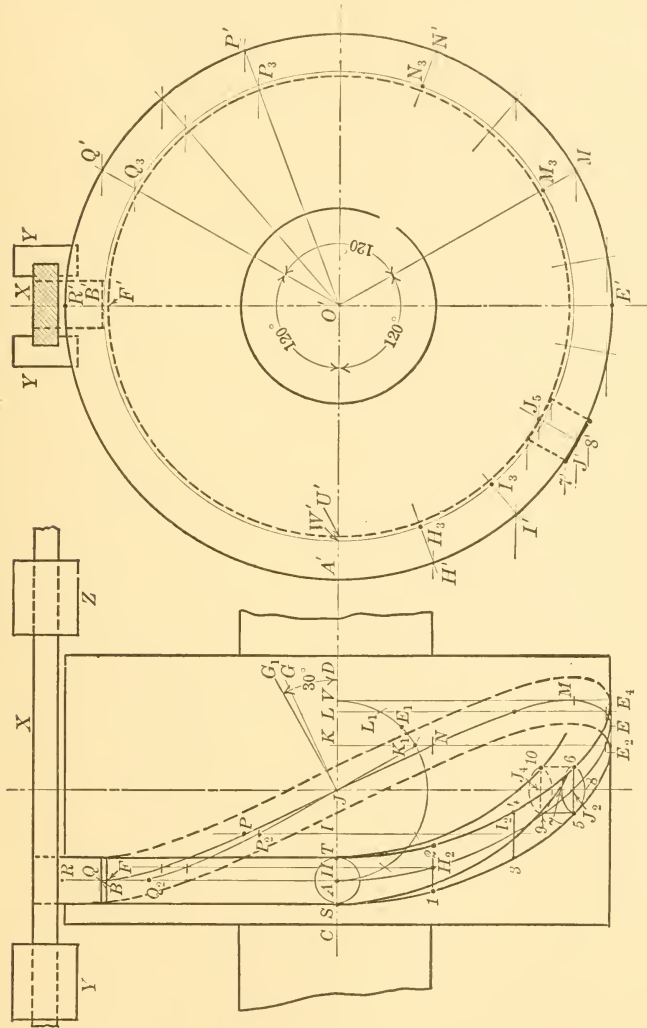

FIG. 148.—CYLINDRICAL CAM, SHOWING TRUE PITCH CYLINDER AND TRUE PRESSURE ANGLE; ALSO METHODS OF CONSTRUCTING GROOVE OUTLINES

found points will represent one of the bottom edges, and the curve through 10 , etc., will represent the other.

378. A MORE EXACT METHOD OF DRAWING THE OUTLINES OF THE GROOVE CONSISTS IN DRAWING THE PROJECTION OF A SECTION OF THE PIN

which is tangent to the cylinder. The section will appear in general as an ellipse in the side view and the curves representing the groove edges will be drawn tangent to these ellipses instead of through the extremities of the major axes as described in the preceding paragraph. The detail work for this is shown in Fig. 148 where the straight line $7'-8'$ is the end projection of a pin section which is tangent to the cylinder. The points 7 and 8 are projected from $7'$ and $8'$ and are the extremities of the minor axis of the ellipse; the horizontal line, $5-6$ passing through J_2 is equal to the diameter of the pin and is equal to the major axis. J_2 is projected from J' . The ellipse $5, 7, 6, 8$, is now constructed, as shown. Similar ellipses should be constructed at other points as at I_2, H_2 , etc. At A the ellipse becomes a circle and at E it flattens to a straight line. The curve $S E_2$ drawn *tangent to the ellipses* instead of through the extremities of the major axes will be one of the surface edges of the groove. Even with this refined method of construction there remains an approximation, for it will be evident that the circle at the top of the pin lies in a plane which is tangent to the cylinder and that the projection of this circle gives an ellipse that does not lie on the surface of the cylinder. Therefore, the curve drawn tangent to the ellipse would not lie on the cylinder. The error, however, in following the above directions is too small to show in a drawing of practical proportions. If desired, this slight error in construction may be corrected by rounding off the end of the pin to conform with the curve of the cylinder and projecting the curve of the rounded end of the pin to the side view to give the elliptical-like curve to which the groove curve is tangent. This is illustrated in a case of exaggerated proportions in Fig. 149 where M is a true ellipse and is a projection of the end of the pin when it is flat. N is a projection of the perimeter of the pin when its end is rounded off to conform with the curve of the cylinder.

379. FORMS OF FOLLOWER PINS FOR CYLINDRICAL CAMS. Cylinders, cones and hyperboloids may be used for the form of follower pins to work in the groove of cylindrical cams. A cylindrical pin, drawn to a large scale, is shown at GJ in Fig. 149 lying in a groove which is cut in the cam cylinder CZ . The cylindrical pin is advanced longitudinally the distance EF , Fig. 149, while the cam turns through the angle $A_1 O_1 A_5$, Fig. 150. The top edges of the groove are represented by the helical curves GG_4 and HH_4 , Fig. 149, and the bottom lines of the working side surfaces of the groove are represented

by II_4 and JJ_4 . The center of the follower pin is shown in its central position at A_2 . The straight line A_2G_2 is a normal to the top pitch line AA_2A_4 of the groove, and it is the line of pressure between the side of the groove and the follower pin at the surface of the cylinder. The angle KA_2O is the pressure angle at the top of the pin and it is made 30° in this example as shown in Fig. 149. The straight line A_2I_2 is a normal to the helix BA_2B_4 which is the locus of the center point of the bottom of the follower pin. The line A_2I_2 , then, is the line of pressure between the side of the groove and the pin at the bottom of the pin, and LA_2O is the pressure angle at the bottom of the pin. The pressure angle, therefore, varies from the top to the bottom of the groove, being smallest at the top. From this it follows that the pitch surface of a cylindrical cam should be at the shortest radius reached by the follower pin rather than at the outer surface where it is usually taken, provided it is desired not to exceed a given maximum pressure angle on the follower pin.

380. WHEN THE PIN IS MOVING, THE LINE OF CONTACT between the side of the groove and the side of a cylindrical pin is a curved line, and one phase is shown in end projection at G_2I_2 in Fig. 149 and in side projection at G_1I_1 in Fig. 150. When the pin is not moving it has straight-line contact with the side of the groove as shown at GI in Fig. 149. If the follower pin is fixed in the frame that carries it, it will receive wear on the forward stroke entirely within the area GG_6I_6IG , Fig. 149. G_6 is the same horizontal distance from the vertical centerline through A as G_2 is from the vertical centerline through A_2 .

381. A ROTATING CYLINDRICAL PIN CANNOT HAVE PURE ROLLING ACTION AGAINST THE SIDE OF THE GROOVE in a cylindrical cam, for such action requires at least that two rolling curves must measure off their lengths equally on each other. This means that if the circumference of the follower pin at the top goes a certain number of times in the curve GG_2G_4 , the circumference at the bottom must go the same number of times into the curve II_2I_4 . This, of course, cannot happen with a cylindrical pin for the circumferences of the pin are the same top and bottom while the helical curves at the top and bottom of the groove against which they operate are totally different in length. From the above it follows that there will be considerable sliding between a cylindrical pin and cylindrical cam and that this will be greater, the greater the length of the pin.

382. A CONICAL FOLLOWER PIN for a cylindrical cam is shown at $M_1 R_1$ in Fig. 150 and in end view in Fig. 151. In the latter view the line $G G_1$ is tangent to the helix which marks the center of the top of the groove and $A_2 G_2$ is normal to it, giving the point G_2 at which the conical pin is tangent to the side of the groove at the outer circumference. The conical pin is here taken the same size at the top as the cylindrical pin in Fig. 149 and consequently the line $A_2 G_2$ in Fig. 151 will be parallel and equal to the line $A_2 G_2$ in Fig. 149. Likewise I_2 , Fig. 151, is the point of tangency at the inner end of the pin. These points of tangency, and intermediate ones, will determine the line of contact $G_2 I_2$ between the conical pin and the side of the groove for the position shown. This line is also shown in side projection at $G_3 I_3$ in Fig. 150. If the pin is rigidly attached to the follower framework the wear on the pin will fall on the area represented by the surface $S_1 S_3 I_3 G_3$. If the pin is free to turn on its axis it will come nearest to having rolling action when the circumference at the bottom of the conical pin is to the circumference at the top as the length of the helix $B B_4$ is to the helix $A A_4$ in Fig. 149, or, when the conical vertex of the roller is at O_1 , Fig. 150, on the centerline of the cylinder. Conical pins give thrust in an axial direction and consequently there must be special provision in the follower framework for holding the pin in place. Conical pins have a natural advantage in that they may be designed to move in axially and so to take up wear in the pin and in the groove.

383. AN HYPERBOLOIDAL FOLLOWER PIN is shown at $T_1 U_1 V_1 W_1$ in Fig. 150 and in end view in Fig. 152. In the latter Figure the lines $A_2 G_2$ and $A_2 I_2$ are perpendicular to the top and bottom helices of the groove respectively, the same as the similarly lettered lines in Fig. 149. If the diameters $T_1 W_1$ and $U_1 V_1$ are taken in the same ratio to each other as the lengths of the top and bottom helices of the groove in which the pin rolls the closest approximation to rolling action will be obtained. There cannot be pure rolling of the hyperboloidal pin, however, on the side of the groove, for, even where the circular sections of an hyperboloidal pin measure themselves off equally on the corresponding helices on the surface against which they roll, there is always an inherent fundamental endwise or longitudinal component of sliding in the direction of the axis of the pin in every hyperloidal action. The nature and amount of this characteristic is explained in some of the books on descriptive geometry.

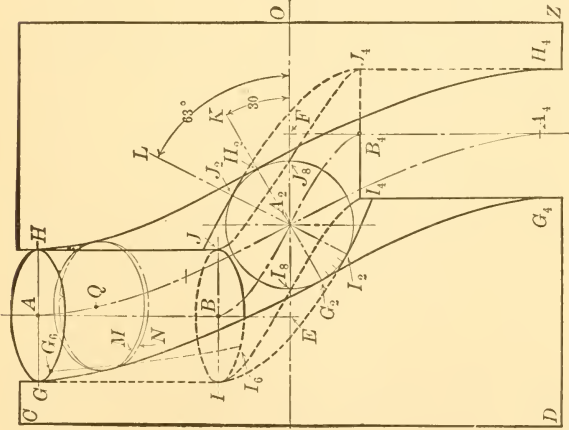

Fig. 149.

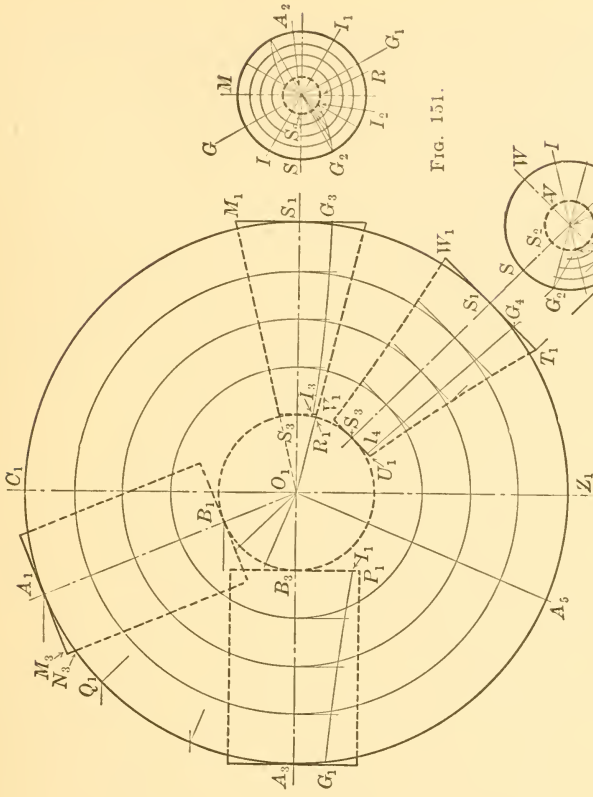

Fig. 150.

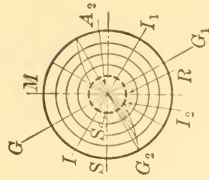

Fig. 151.



Fig. 152.

Figs. 149 to 152.—SHOWING USE OF CYLINDRICAL, CONICAL AND HYPERBOLOIDAL FOLLOWER PINS IN CYLINDRICAL CAM GROOVES

contact between the pin and the groove at the maximum pressure angle, and the curved hyperboloidal line $S_1 S_3$ the line of contact at the end of the stroke. The wear on a pin fixed in the follower frame would occur on the hyperboloidal surface between these two lines.

385. PLATES FOR CYLINDRICAL CAMS. Instead of actually cutting grooves in cylinders, flat cam plates are often formed and then curved to the diameter of a cylinder and screwed on. The follower pin then works against the edge of the formed plate. Such a case, illustrated from the working drawings of an automatic machine, is given in Figs. 153 and 154. Fig. 153 is a development of the plate as first laid out, and Fig. 154 an end view of the plate after it is curved and ready to be applied to the blank cylinder by fastening

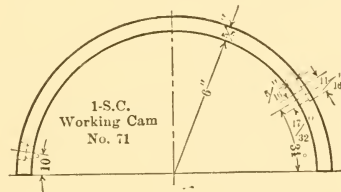

FIG. 154.—CAM PLATE FORMED TO FIT BLANK CYLINDER

screws as indicated. The developed cam surface, as shown in this illustration, has a straight line and gives uniform velocity to the follower pin.

386. ADJUSTABLE CYLINDRICAL CAMS IN AUTOMATIC WORK FOR PROCESSES INVOLVING VARYING SIZES OF PRODUCT. By making a series of plates of varying proportions, but curved to fit a single pitch cylinder which remains permanently in place, and by fastening the proper series of plates to the cylinder for a given job, the same automatic machine is made to turn out products of varying sizes without removing cam bodies from shafts. A type of automatic machine in which such curved cam plates are used is the screw manufacturing machine. A diagram of a blank cylindrical cam with curved cam plates fastened on is shown in Fig. 11.

387. DOUBLE-SCREW CYLINDRICAL CAM. This is the cylindrical grooved cam with specially formed follower pin or head adapted to give long ranges of reciprocating motion to a follower bar. The cam may be constructed to give uniform or variable velocity to the follower throughout its entire range of motion; also to give periods of rest at the end of the stroke, if desired, ranging anywhere from zero

to periods measured by the time required for the cam to make about $1\frac{2}{3}$ turns. The form of the follower pin should be as indicated in general way in Fig. 155 being elongated at J, J_1 , so as to take the open space at two intersecting grooves and at the same time so as not to bind at the reverse position at the end of the stroke as at C , Fig. 155.

388. If the follower motion is uniform throughout the entire length of both strokes, the right and left grooves $C D M$ and $L F C$ respectively in Fig. 155 will have a true helix for their pitch line. The angle at the end of the screw formed by the intersecting helices may be eased off as shown in Fig. 157, by the change from $C_1 Y$ to $R Y$. If it is desired to have the follower pause at the end of the stroke, the helical groove will run into a groove whose sides are

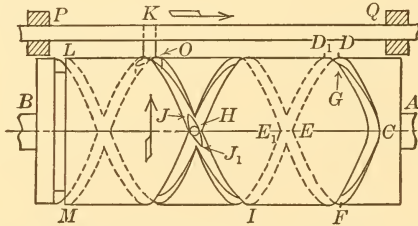

FIG. 155.—DOUBLE SCREW CAM WITH HALF TURN STOP

bounded by planes perpendicular to the axis of the cylindrical cam, as shown at LM , Fig. 155. The length of the stop of the follower will be equal to the time required for the cam to make one-half a turn in this case, as shown in Fig. 155, and to about $\frac{3}{4}$ turn if made as shown at $CDEF$ in Fig. 156. This is about the practical limit for time of stop for a simple groove construction.

389. PERIODS OF REST CORRESPONDING TO MORE THAN ONE REVOLUTION OF THE CAM may be obtained by a special attachment shown at HN in Fig. 156. A movable triangular piece, H , turns through an angle of a few degrees on a pin J which is mounted on a small sliding block that is constantly pressed to the left by the spring N . If the follower head VK is imagined to move around the cam, it will, shortly after passing M press the tip S of the piece H causing it to turn slightly on the pin J and so leaving a full vertical opening at T which the follower head will enter after passing L on its way around. The follower head, having entered the large open end of the groove at TS will move the block H to the right against the

spring pressure at *N* as it passes; and as the follower head moves toward and past *S*, the spring *N* will cause the tip *T* of the block to move to the left and so open full the inclined groove *LMI* for the follower head to enter the next time it comes around.

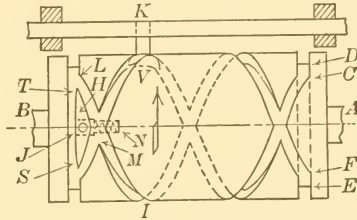

FIG. 156.—DOUBLE SCREW CAM WITH $\frac{1}{4}$ AND $1\frac{1}{4}$ TURN STOPS

390. A SLOW ADVANCE OF THE FOLLOWER AND A QUICK RETURN may be obtained with the double screw cam, as shown in Fig. 157, when the time for the travel of the follower bar *PKQ* to the right is represented by two turns of the cam, while the return motion to the left will be made in one turn of the cam as shown by the increased (double) pitch of the helical groove *RF L*. To accurately represent the helical grooves where the pitches are different, as in this case, it

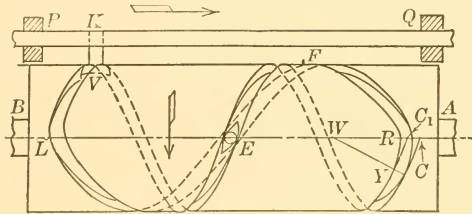

FIG. 157.—DOUBLE SCREW CAM FOR SLOW ADVANCE AND QUICK RETURN OF FOLLOWER

must be kept in mind that the normal distance between helices must always be equal to the effective diameter of the follower pin and that this will give a wider groove, measured parallel to the axis, when the pitch is large than when it is small. This is shown at *E*, Fig. 157, where the large pitch and small pitch grooves are tangent to the circle on the follower head. The pitch of the helix or groove is the longitudinal or axial advance of the follower in one full turn of the cylinder. It is shown in Fig. 155 by the distance *DO*.

391. The helical groove shown in Fig. 155 gives uniform motion to the follower, and the helical curves which bound the groove are

obtained as above is used, but if exact angular acceleration is required the method described in paragraph 136 *et seq.*, for the cylindrical cam chart must be followed. In this case the cam chart becomes the sliding plate cam.

394. INVOLUTE CAM. The involute curve may be used for cam outlines. It gives a characteristic motion almost identical with the cam having a straight-line base curve (paragraph 32), but it is not so simple to construct. The involute cam will not give true motion to a roller follower unless the ends of the cam working surface are eased off, as they are in the straight-line combination cam, or the logarithmic combination cam (paragraphs 33, 56, 59, and 199) by arcs of circles or other curves. For the same data as were taken for comparison of cams shown in Figs. 71, 75, 79, etc., the involute curve gives a slightly larger cam than does the straight-line base curve, the maximum radius being 2.78 for the former and 2.65 for the latter. The method of finding the maximum radius for the involute cam will be explained in the next problem.

395. THE INVOLUTE IS POPULARLY DEFINED as the curve that would be generated by a point on a string which is being unwound from the periphery of a circular disk, the string always being kept taut and always in the same plane as the disk.

396. THE INVOLUTE IS READILY CONSTRUCTED, according to the preceding definition, by drawing a circle of any size, as illustrated at SPR , Fig. 159; taking any point as S as the origin of the involute; laying off a series of equal angles, of any desired unit, as at SOM , MON , etc.; drawing tangents to the circle at M , N , etc.; and making the lengths MY , NU of the tangents equal, successively, to the lengths of the arcs MS , NS , etc. This latter operation may be done graphically by setting the small dividers to a step of $\frac{1}{4}$ inch or less, starting at S and counting the steps toward M until M is reached or passed, and then counting off the same number of steps in the reverse direction going along the tangent line, thus obtaining the point Y on the involute curve. This graphical method of stepping off distances, although generally used, is apt to give an appreciable cumulative error, and therefore should be checked by a simple computation as follows: Length of tangent NU , for example, equals length of arc NS , equals $\frac{OS \times 2 \times 3.14 \times \text{angle } NOS \text{ in degrees}}{360}$. In general it is advisable to first compute and draw a long tangential line as RW at 180° from S , and then if six equally spaced construc-

equals the shortest pitch radius of the cam. With this value known it is a simple matter to draw the required involute cam as in Fig. 161, where OA equals x as just computed, HAK equals the pressure angle of 30° , and the line HA extended is tangent to the base circle $E Q$, which is necessary in the drawing of the desired involute. With these items laid down, the involute pitch surface from A to F is constructed in detail as described above in the paragraph devoted to the construction of the involute, and briefly, in review, as indicated in the following paragraph.

401. Lay off the assigned working angle of 60° as at AOF , Fig. 161. Make OF equal to AO plus the assigned motion of the

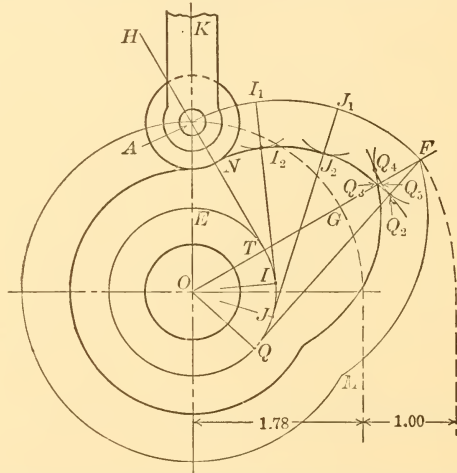

FIG. 161.—PROBLEM 41, INVOLUTE CAM FOR RADIAL FOLLOWER BASED ON THE SPECIFIC DATA

follower which is one unit in this problem. Draw FQ tangent to the base circle. HT is tangent to the base circle. Divide the arc TQ as at I and J into a convenient number of equal parts, three being taken in this illustration. Draw tangents at I and J . Step off the distance ATI on AI_1 thus obtaining I_1 , etc. Draw the involute curve through A, I_1, J_1, F , thus obtaining the involute pitch surface of the cam. The working surface, if a roller is used, is found by taking the radius of the roller and drawing a series of arcs with I_1, J_1 , etc., as centers and drawing a curve tangent to them as at I_2, J_2 , etc. It will be observed that a working curve so drawn will be tangent to the last construction arc at Q_2 on one side of the cam lobe and

tangent at Q_4 on the other side, giving the actual tip of the working cam surface at Q_3 . This means that if the roller follower is to move with a velocity characteristic of the involute curve, that its ultimate stroke will be less than the desired amount by the distance Q_3, Q_5 . This can only be corrected, when a roller follower is used, by disregarding the involute characteristics at the end of the stroke, and by arbitrarily changing the true working surface curve from J_2 to Q_3 so that the curve will run smoothly from J_2 to Q_5 .

402. THE INVOLUTE CURVE HAS A FIXED INITIAL ANGLE FOR EACH PRESSURE ANGLE. For example, the initial angle SOA , Fig. 160, will always be $39\frac{1}{2}^\circ$ for a maximum pressure angle of 30° no matter what size of involute is used. This may be readily shown as follows: Let y equal the angle SOA which is the initial angle from the origin of the involute to the point where the pressure angle is to be shown. Let a be the assigned pressure angle as represented at HAK . Then the angle $SOT = y + (90^\circ - a^\circ)$. Let x equal OT , the radius of the base circle of the involute. Then, $x \cot a = AT = \text{arc } ST = 2\pi x \frac{y + 90 - a}{360}$. The value of x cancels, and for a pressure angle of 30° substituted for a , y is found to be $39\frac{1}{2}^\circ$. Similarly the initial angle is found to be 18° for a pressure angle of 40° .

403. INVOLUTE SPECIALLY ADAPTED FOR A FLAT-SURFACE FOLLOWER. The involute curve is naturally adapted for an oscillating cam surface where a flat-surface follower is used, and in this case it gives a uniform linear velocity to the follower. The natural advantage of an involute cam for a flat-surface follower, shown in Fig. 162, is based on the property of an involute that the tangent XY to the base circle RQ is normal to the involute as at Y , and consequently that the perpendicular line at TZ is tangent to the involute. Therefore, TU may represent the flat surface of a follower collar attached to the follower rod SS_1 . T_1U_1 is the follower in its highest position, and T_2U_2 in its lowest position, considering that only the part AC of the cam surface is used. An involute curve cam as from A to C would always be tangent to the flat surface of the follower and the line of contact between cam and collar would pass through the center of the follower rod, moving up and down between Y_2 and Y_1 . This means that there is no pressure angle on the follower rod except that due to friction. This last feature of the involute cam gives it, perhaps, its greatest practical importance. Where it is desired to give the follower a definite velocity and acceleration between its extreme

points of travel, Y_2, Y_1 , the involute cannot be used and the method explained in paragraph 76 *et seq.* must be used.

404. OSCILLATING POSITIVE DRIVE SINGLE-DISK CAM. This cam, illustrated in Fig. 163, might be compared with the yoke cam having a swinging follower instead of a reciprocating follower. Its method of construction, however, differs from that of the yoke cam. In the illustration the oscillating cam $L K M$ receives its motion through the link $F G$, the point F swinging through the arc $F_1 F_6$. The follower piece $C B D E$ swings about the fixed center B through the angle $E_1 B E_6$. The pitch surfaces $C_6 C_1$ and $D_6 D_1$ are found by considering the cam to remain stationary while the follower revolves around it in such a way as to retain its relative working

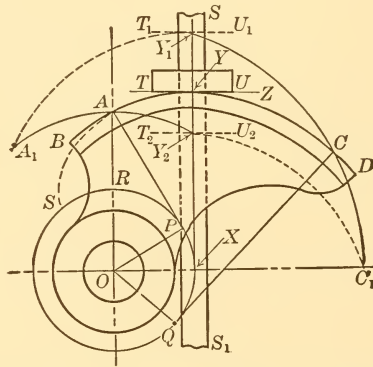

FIG. 162.—SHOWING THAT THE INVOLUTE IS SPECIALLY ADAPTED FOR AN OFFSET FLAT SURFACE FOLLOWER

position at all phases. The detail construction necessary to do this is as follows: Through the point B draw the arc $B_1 B_6$ to include the same angle as the arc $F_1 F_6$. Divide arc $B_1 B_6$ into a number of equal parts if the shaft A is to turn with uniform angular velocity; six parts are used here. With points B_1, B_2 as centers and distance BC as a radius draw short arcs as indicated at C_1, C_2 , etc. The point C moves in an arc $C' C''$ through the same angle as does the point E .

405. If it is desired that the follower move with angular acceleration and retardation similar to that produced by the crank curve, draw the semicircle having $C J$, Fig. 163, for a radius, divide it into the same number of parts as B_1, B_6 was divided (six in this case) and project the division points J_1, J_2 , etc., to the arc $C' C''$ which has B

for its center. Carry these last points around, with A as a center, until they meet the corresponding arcs which have been already drawn with B_1, B_2 , etc., as centers. Thus, the points $C_1 \dots C_6$ of the pitch surface will be obtained. The points $D_1 \dots D_6$ of the companion pitch surface are obtained in the same way. The radius CJ is equal to one-half the chord of the arc $C' C''$. Taking

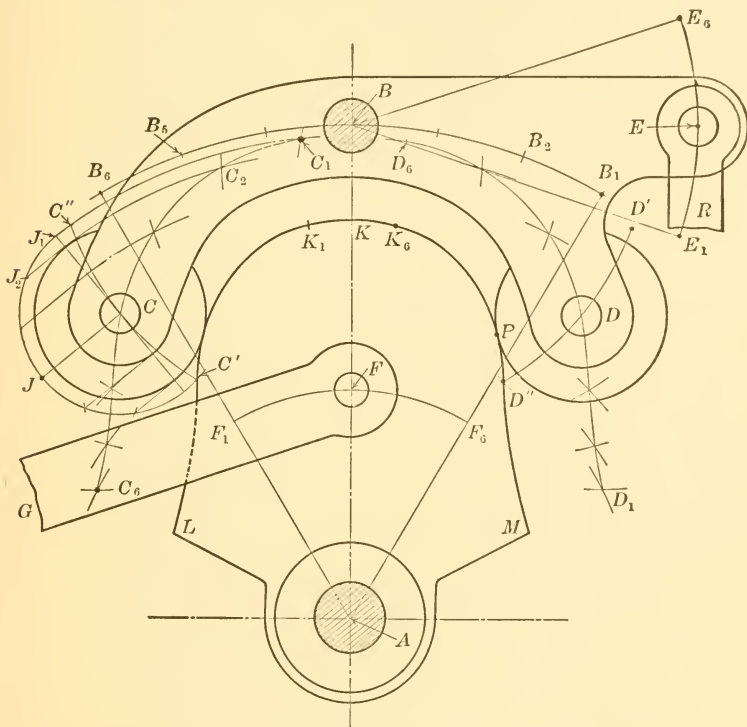

FIG. 163.—OSCILLATING POSITIVE DRIVE SINGLE DISK CAM

the radius of the roller to be DP the working surfaces $K_6 M$ and $K_1 L$ are obtained.

406. With the above type of cam, extreme accuracy is necessary in manufacture to overcome any binding action of the rollers on the cam disk. To overcome this a cam construction has been devised in which the two arms BC and BD , Fig. 163, are entirely separated, the former being keyed to the shaft B and the latter free to turn on shaft B . The two arms are then connected by a spring, as illustrated in Fig. 166, which keeps them drawn to each other, and both having

the desired pressure on the cam surface. To prevent too great a pressure of the arms on the cam surface, should too heavy a spring be used, a stop pin is cast on each arm and these stops come together just as the follower rollers touch the cam surface when newly adjusted.

407. CAM SHAFT ACTING AS GUIDE. A special form of construction for guiding the cam follower is frequently used as illustrated in Figs. 164 and 165. The cam B in Fig. 164 is the simple radial cam and is constructed for any given data as explained in paragraphs 49 *et seq.* It moves the roller C , which is attached to the forked arm $R D$, back and forth in approximately a radial line the distance $A M$ minus $A L$ which is equal to the chord of the arc $E D$. The arc $E D$ measures the swing of the shaft F . The follower rod $D R$ is under

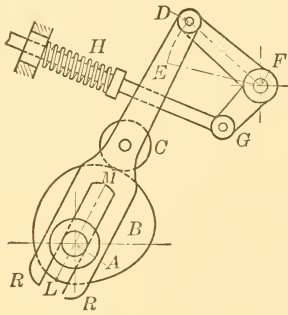

FIG. 164.

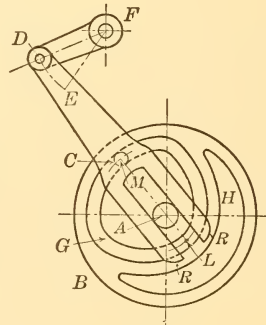

FIG. 165.

FIG. 164.—CAM SHAFT GUIDE TAKES PLACE OF CROSSHEAD GUIDE
 FIG. 165.—POSITIVE DRIVE WITH CAM SHAFT GUIDE

definite control all of the time, although its form of construction is extremely simple and the number of parts a minimum. The forked end $R R$ of the follower rod bears with a snug fit against the two sides of the cam shaft, or against adjustable collars attached to the shaft. In Fig. 164 the follower shaft F is returned to its initial position by means of the spring H .

408. POSITIVE DRIVE WITH CAM SHAFT AS GUIDE. A cam giving positive motion where the cam shaft is used as a follower guide is illustrated in Fig. 165. The cam itself is a face cam and is constructed for any given data as directed in paragraphs 96 *et seq.* The pin C is attached to the follower rod $D R$ and is moved back and forth in approximately a radial position by the amount $A M$ minus $A L$, equal to the chord of $D E$. The forked end of the follower rod,

bearing against the sides of the cam shaft A , together with the guided end D of the rod give it a motion that is under control at all phases, and this with a minimum amount of mechanical construction. The shaft F is under positive cam control all the time on account of the use of the face cam, and no return spring is necessary as in Fig. 164.

409. POSITIVE DRIVE DOUBLE DISK RADIAL CAM WITH SWINGING FOLLOWER. A special form of cam and follower construction, where positive action is desired, is shown in Fig. 166 where the following data are so taken:

(a) That two follower arms 10 units long shall each swing through an angle of 20° with uniform acceleration and retardation while two corresponding radial cams turn through 135° , the drive to be positive with each roller having a single point of contact.

(b) That the follower arms shall be returned with positive action while the cams turn through 225° .

(c) That the angle between the two radial follower arms shall be 50° .

410. The follower shaft A , Fig. 166, is first laid down, the angle of follower-arm swing of 20° then drawn as at BAC , and finally the 10 units for follower-arm length laid off at the initial position AB . The horizontal centerline EO for the cam shaft is then drawn across the arc BC so that the midpoint D is as much above it as the end points B and C are below. The radius OD of the pitch circle is computed in the usual way, taking the chord BC for the distance moved by the follower point. Then $DO = \frac{BC \times 3.46 \times 360}{6.28 \times 135} = 5.16$, thus locating the cam center O . The circle represented by AA_1 is then drawn and the pitch surface, indicated by the short portion BB_1 is constructed in exactly the same manner as explained in Problem 8. The size of the roller is assumed as shown at BF and the working surface of the operating cam FG is drawn. The operating arm AB is keyed to the shaft A .

411. The return arm AH , Fig. 166, is not keyed to the shaft A but turns freely on it instead. The motion of this arm should be identical with that of the arm AB and, therefore, the swinging arc HJ of the center of the follower roller is made the same as the arc BC , and it is similarly divided. The pitch surface of the return cam is represented in part at HH_1 and is found in exactly the same way as directed in the preceding paragraph, and the working surface

KL drawn. The spring at M exerts more pull than is required to return the follower, and, therefore, it holds the two follower arms against the cams with practically uniform pressure, even should there be slight inaccuracies in workmanship, or wear in the contact surfaces. A lug is attached to each follower arm as shown at P and Q ,

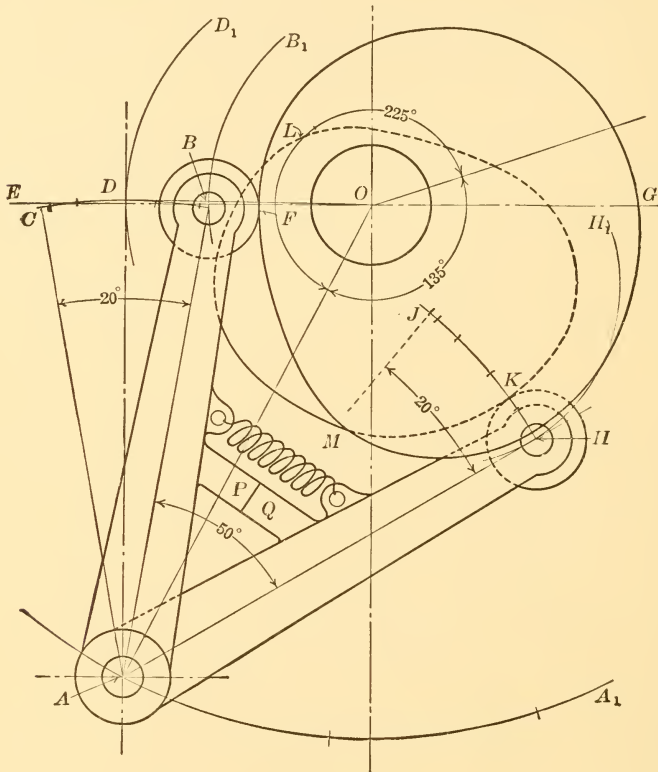

FIG. 166.—OSCILLATING POSITIVE DRIVE DOUBLE DISK CAM

and these act as stops in preventing excessive pressure of the rollers on the cam surfaces. Cams used in this way have been called duplex cams.

412. ROTARY SLIDING YOKE CAMS GIVING INTERMITTENT HARMONIC MOTION. A yoke cam driven by sliding contact instead of roller contact is shown in Fig. 167. The cam, in this figure, is in the form of an equilateral triangle bounded by equal circular arcs having a radius equal to the straight sides of the inscribed triangle. The cen-

ters for the circular arcs are at the apexes of the triangle. One of the apexes of the cam is at the center of the driving shaft. The motion given to the follower yoke will be an intermittent one, dwelling at the ends of the stroke, and the total travel will be equal to the radius of the cam surface. The follower will travel from one end of its stroke to the other with a simple harmonic motion the same as with crank and connecting rod where the connecting rod is assumed to be of infinite length. Or, the motion during the stroke will be the same as with the Scotch yoke, or crank and slotted crosshead, where the radius of the crank is one-half the radius of the present cam surface.

413. A diagram of the motion of the yoke follower in Fig. 167 is shown at *M N S*. With the cam turning as shown by the arrow, the

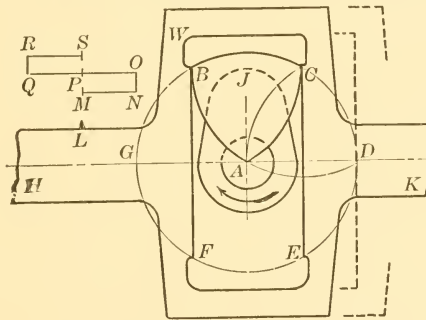

FIG. 167.—SLIDING YOKE CAM GIVING HARMONIC MOTION

follower *H K* will move the distance *M N* while *C* on the cam turns 60° to *D*, and the cam edge at *C* will do the driving with a scraping, sliding action. While *C* is turning 60° from *D* to *E*, the follower will remain at rest; while *C* is turning 60° from *E* to *F* the curved surface *A C* of the cam will be driving the follower the distance *O P* with a rubbing, sliding action and increasing velocity; while *C* is turning from *F* to *G* the cam edge *C* will again be driving, the follower moving the distance *P Q* with a scraping, sliding action and decreasing velocity. The smooth working surface of the follower yoke is shown from *F* to *B*, while the recessed surface as at *W* may be left rough cast. The velocity and acceleration diagrams for the equilateral sliding yoke cam here described have the same characteristics as those shown for the ordinary crank curve cam, illustrated in Figs. 88 and 89.

414. ROTARY SLIDING YOKE CAM GIVING RECIPROCATING HARMONIC MOTION. A circle passing through the points *A B C*, Fig. 167

would represent the surface of a cam attached to the crank AJ , and such a cam, instead of the equilateral curved side cam, which is shown, would give a simple harmonic motion to the follower yoke without finite periods of rest at the ends of the stroke. Such a circular cam would be an equivalent of a crank and slotted crosshead where the radius of the crank would be equal to the radius of the cam circle.

415. A ROTARY SLIDING YOKE CAM, GENERAL CASE, with the cam surface entirely surrounding the shaft is shown in Fig. 168. To lay

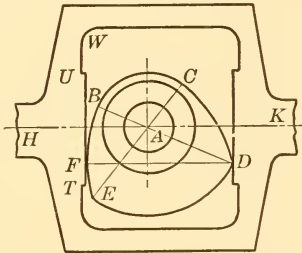

FIG. 168.—SLIDING YOKE CAM
GENERAL CASE

out this cam for a definite range of motion, say 2 units, draw the indefinite circular arc BC with any desired radius and the arc ED with the same center and with a radius 2 units larger. Then with a radius equal to AB plus AE and a center anywhere on the arc ED draw the arc CD until it intersects ED as at D . With D as a center and the same radius as before draw the arc EB completing the cam. The student should

be able to determine the angles traveled by the cam while the follower is at rest, the angles of motion, the range of motion of the follower, and the exact portion of the follower working surface which has to resist the wear due to sliding action.

416. CAM SURFACE ON RECIPROCATING FOLLOWER ROD. In some special forms of cam construction it is more convenient to place the cam curve on the follower than on the driver. Such a case is illustrated in Fig. 169 where the cam curve $EF E'$ is on the sliding follower bar KG . The driving crank AF carries a pin at F which slides in the cam groove. The mechanism here shown is a modification of the Scotch yoke, or "infinite connecting rod." The motion in this case is such that the follower remains stationary, while the driving shaft turns through the angle $C'AC$. The curve $C'FC$ is an arc of a circle with A as a center. The follower then picks up motion comparatively slowly, the point G being at the points 1, 2, 3, etc., when the crank pin F is at the points which are correspondingly represented in Roman numerals. When the crank pin is at J , G is at N and it then moves very rapidly from N to P while the crank pin travels from J to Q . Very often, in cam work, the driving shaft A has only an oscillating motion through 90° or less. If the curve $C'FC$ is changed slightly so as not to be an arc of a circle with A

as a center, the end *G* of the follower bar will not come to rest for a definite period at the end of the stroke, but it will have a slow, powerful motion which may be made use of in manufacturing processes where compression is required.

417. PROBLEM 42. DEFINITE MOTION WHERE CAM SURFACE IS ON FOLLOWER ROD. In Fig. 169 a follower rod *GK* has a cam surface formed at the left-hand end from *E* to *E'*, and it is driven by a simple crank pin represented at *F* so as to secure a desired or known motion. In the illustration let it be desired:

1st. That the follower rod shall remain at rest at the head end of the stroke while the driving crank pin turns 45° ($22\frac{1}{2}^\circ$ on each side of the centerline *AF*).

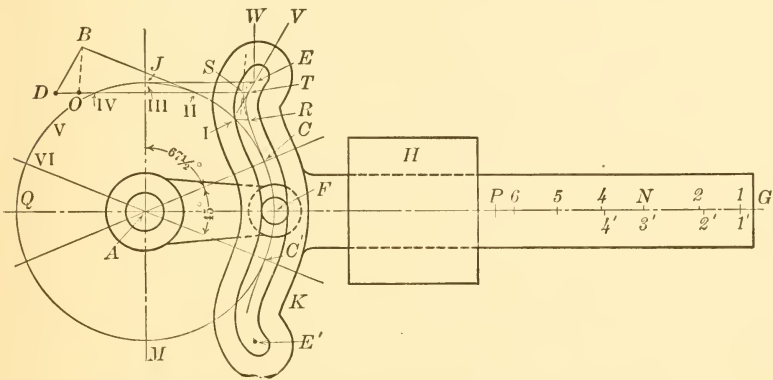

FIG. 169.—CAM SURFACE ON RECIPROCATING FOLLOWER ROD

2d. That the follower will be moved to the left a distance *GN* with uniform acceleration while the crank pin turns $67\frac{1}{2}^\circ$.

3d. That the follower shall move the remainder of the stroke from *N* to *P* while the crank pin turns 90° .

4th. That the follower rod shall move in reverse order on the return stroke from *P* to *G*.

418. Before starting the solution of this problem it should be stated that, one cannot, because of either theoretical or practical considerations, or both combined, always secure desired results in cams of this type where arbitrary distance and motion assignments are given as in this illustration. It is nevertheless advisable to complete the solution of the problem, if possible, on the basis of the desired data, because one can then make the necessary modifications

with a sure knowledge that the least departure has been made from the theoretical or assigned conditions.

419. The method of solution for the above data is as follows: Assume the driving crank length AF and draw the crank-pin circle FJM . Lay off the angle FAC equal to $22\frac{1}{2}^\circ$. The circular arc FC will then be part of the pitch line of the follower cam head, and while the crank pin F is moving through this arc the follower rod will not move at all. To secure uniform acceleration of the follower for the distance GN , divide GN into 9 equal parts and mark the 1st, and 4th division points as indicated at $1'$ and $2'$ in the figure. This will be the first step in securing the uniform acceleration called for because the distance from G to $1'$ will be one unit, from $1'$ to $2'$ will be three units, and from $2'$ to $3'$ will be five units. By dividing GN into three parts as here described, three construction points will be secured on the cam curve. If more construction points are desired, GN may be divided in 16 equal parts and the 1st, 4th and 9th intermediate division points taken, thus obtaining four construction points on the part of the pitch surface of the cam from C to E . Likewise, if five construction points are desired, GN would be divided into 25 equal parts, and the 1st, 4th, 9th, and 16th division points taken.

420. Since the motion from G to N is to take place while the crank pin moves $67\frac{1}{2}^\circ$ as called for in the data, and since three construction points have been used in this illustration, the $67\frac{1}{2}^\circ$ arc from C to J is now divided into 3 equal parts as indicated at I and II in Fig. 169. At I draw a horizontal line and make the distance $I-R$ equal to $1'-G$; at II make the distance $II-S$ equal to $2'-G$; and at J , make the distance $III-E$ equal to $3'-G$. A curve through the points C , R , S and E will be the pitch line for the cam surface on the follower rod for uniform acceleration from G to N . The point $3'$ coincides with N .

421. The part of this pitch curve from R to E is shown by a dash line and is not practical because of the sharp curvature from S to E , which would produce too large a pressure angle and this in turn would give a large bending moment on the follower arm and large side pressure in the bearing H . This part of the curve should, therefore, be modified, and a good plan on which to effect the modification is to start by making the pressure angle as large as is practically allowable and then to keep the new curve as near to the old as possible. A maximum pressure angle that is safe under all ordinary circumstances is 30° and, therefore, the first step in the modification

will be to draw a vertical line through E , the end of the theoretical curve, and make an angle of $W E V$ equal to the maximum practical pressure angle of 30° . The line $V E$ is then produced until it crosses the dash curve, and a smooth curve is next drawn so as to connect the straight line and the original curve. This will leave, in this case, $E T$ as a straight 30° line, $T R$ as a new assumed part of the pitch curve, and $R F$ as the portion of the original curve that remains. If the cam is to turn slowly, or if the load on the cam is not large, a greater pressure angle could be taken at $W E V$ and then the arbitrary new curve would come closer to the original or theoretical curve.

422. The practical pitch line of the cam is now found to be $F C R T E$. The cam will run smoothly and the variation in the motion of the cam from the originally desired motion may be partially indicated by pointing out that the end G of the follower will be at 2 , and at 4 instead of $2'$ and $4'$ as originally intended. This variation may be most completely shown by a velocity diagram which will be taken up in a succeeding paragraph.

423. The pitch curve $F T E$, it will be noted, has been constructed to give a definite practical action to the follower from G to N . Since the curve $F E$ is now determined, and since the crank pin must drive through the same cam slot from E to F while it turns through the remaining arc $J Q$, it follows that the motion of the rod from N to P cannot be assigned, and that it must be taken as it comes. To find out in a general way what this motion will be it is only necessary to pursue in reverse order the methods already used; *i.e.*, to lay off the distance $T-IV$ at $G-4$, the distance $R-V$ at $G-5$, etc. By noting the distances $N-4$, $4-5$, etc., which the follower rod travels in uniform periods of time, some useful idea of the retardation, and consequently of the smoothness of action of the cam may be obtained as it approaches the inward end of its stroke. In the illustration the follower rod will slow down perceptibly from N to 4 , and have slightly higher but a fairly uniform velocity from 4 to 5 , and from 5 to 6 . It will retard rapidly from 6 to the end of the stroke.

424. The lower part of the pitch curve from F to E' will be made symmetrical with the upper part from F to E in this problem thus making the action of the follower on the return stroke the reverse of what it is on the forward stroke. If it were desired, the curve $F E'$ could be constructed, by the methods described above to give

Through the point B draw a line BD parallel to the line that is tangent to the cam pitch curve at T . The line VE , continued, is tangent to the cam curve at T because it will be remembered that the practical curve from R to T was taken so as to be tangent at its upper end to the straight line ET . The distance $II-D$ will represent the velocity in feet per second with which the follower rod is sliding through the bearing at H . This velocity is laid off in the time-velocity diagram in Fig. 170 at $2-D$. In a similar manner other points on the solid-line curve CDQ may be found. This curve shows at a glance just how fast the cam follower is moving at every phase of its stroke.

427. The dash line construction in Fig. 170 shows the follower velocities called for in the original data, but abandoned, as explained above, because of the large pressure angle involved. The point O on the dash curve is found by drawing the line BO , Fig. 169, through B parallel to the short straight dash line which is shown tangent to the theoretical curve at S . Then $II-O$ would represent the velocity of the follower bar at phase II if the original data were used. As a check on the accuracy of the construction the points C , L , O and X , Fig. 170, should all be on a straight inclined line, because CX is a velocity line and it must show uniformly increasing velocity for the follower in order that there may be uniform acceleration as called for in the original data.

428. The difference between the solid and dotted parts of the velocity diagram in Fig. 170 shows the effect on the velocity of the follower of arbitrarily changing the theoretical cam curve RSE , Fig. 169, to the more practical cam curve RTE .

429. PROBLEM 43. CAM SURFACE ON SWINGING FOLLOWER ARM. When the cam surface is on the follower and it is desired that the follower shall have a swinging motion instead of a rectilinear reciprocating motion as it had in Fig. 169, the method of construction will vary in detail as illustrated in Fig. 171. The data for Fig. 171 are, that the driving crank AC with a crank-pin roller at G shall swing the follower shaft B through an angle of 30° counterclockwise with uniformly increasing and decreasing angular velocity while the driving shaft turns through 60° with uniform angular velocity in the same direction.

430. The method of locating points on the curve CF of the follower cam pitch surface, Fig. 171, follows: Divide the assigned 30° arc, CE , into any number of parts, say six, which are as to each other as 1, 3, 5, 5, 3, 1. This will provide for the uniformly increasing and

decreasing motion to the shaft *B*. Divide the assigned 60° driver arc, *CD*, into six equal parts. The method of locating the point *L*, which is the second construction point on the cam curve, will be taken for explanation purposes. Other points are found in the same way. Draw a radial line *B2* through the second construction point, continuing it to *J* which is on an arc which passes through *II* on the arc *CD*. Lay off the arc *JK* at *II-L* thus obtaining the point *L* on the cam curve. This form of cam has positive action. When it is

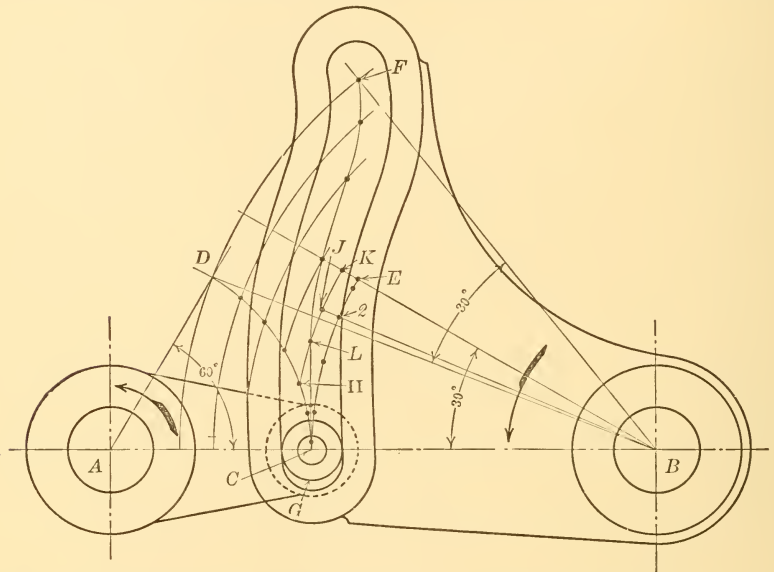

FIG. 171.—PROBLEM 43, CAM SURFACE ON SWINGING FOLLOWER ARM HAVING UNIFORM ANGULAR ACCELERATION AND RETARDATION

allowed to reach a dead center position as shown in Fig. 171, auxiliary action will be required in starting.

431. EFFECT OF SWINGING TRANSMITTER ARM BETWEEN ORDINARY RADIAL CAM AND FOLLOWER. In Fig. 172 let *BCDE* be an ordinary radial cam with straight sides as at *BH* rounded off by circular arcs with center as at *G*. Let *IJK* be the swinging transmitter arm with the working surfaces at *J* and *K* as arcs of circles with centers at *L* and *M* respectively. Let *NN'* be the centerline of the follower rod which moves straight up and down.

432. In order to reach a useful understanding of the action of this type of cam construction it will be necessary to learn the rate of

change of velocities in the follower parts so as to judge the accelerations and retardations which cause the most trouble at high speeds, also to learn the rates of sliding at J and K , and then to balance these against the pressure angle produced by the same radial cam with an ordinary direct roller-end follower.

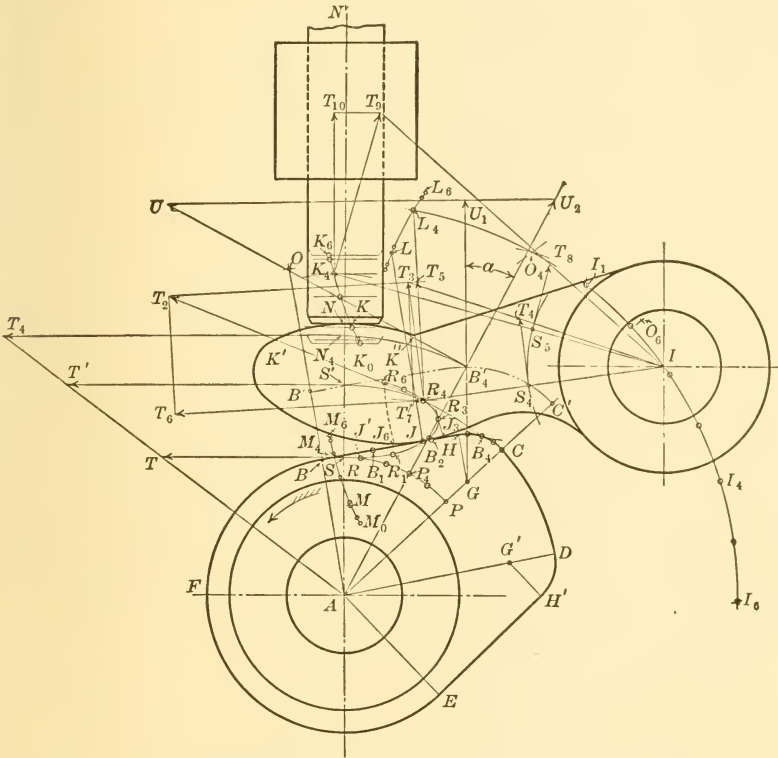

FIG. 172.—SWINGING TRANSMITTER ARM WITH SLIDING ACTION

433. The method of analyzing the cam action in Fig. 172 will be pointed out by using six equally spaced construction points during the period that the surface BC is in action, the cam turning as shown by the arrow. To obtain the positions of the six points for analysis one cannot divide the subtended arc BP of the working surface arc BC into six equal parts where a swinging follower arm is used, as may be recalled from Problems 8 and 11. Instead, it is convenient for analytical construction purposes to revolve the swinging follower arm around the cam with uniform angular velocity while the cam

remains stationary. The detail work necessary to accomplish this is done first by drawing an arc of a circle through I with A as a center, finding where I is on this arc at the beginning and end of action while the arm $I J$ slides on $B C$, and then dividing the arc of swing of I into six equal construction parts.

434. The initial position of I , Fig. 172, is found by laying off the distance $L J$ from the point B on the radial line $A B$, thus obtaining the point O ; then using O as a center and a radius equal to $L I$ draw a new arc to intersect the arc through I at I_1 . This will be the position of I when the swinging arm is tangent to the cam at B ; in a similar manner I_6 will be found to be the position when the arm is tangent at C . With the arc $I_1 I_6$ obtained and divided into six equal parts, it is no longer necessary or convenient to consider the center I as revolving about A , and it will, therefore, be considered as fixed in further work, the next step of which will be to find the six corresponding positions of the point L . This is readily done by drawing an arc through L with I as a center and then taking $I L$ as a radius and the point I_4 , for example, as a center and drawing an arc such as one of the short ones shown at O_4 . Then with a radius equal to $L J$, find by trial, a point on the arc just drawn which will be a center for an arc that is tangent to $B C$ of the cam. This center is shown at O_4 and the tangent arc is shown at B_4 . With A as a center draw an arc through the point O_4 until it cuts the arc through L already drawn, as at L_4 . In the same manner the six points on the arc through L are found, and the corresponding points of tangency on the cam outline $B C$ are obtained as shown from B to C .

435. THE LOCUS OF THE POINT OF CONTACT may now be found, as at $R J R_6$, Fig. 172, as follows: To find, for example, the point R_4 , draw two intersecting arcs, one having $L J$ for a radius and L_4 for a center and the other having $A B_4$ for a radius and A for a center. Similarly other points on $R J R_6$ are found.

436. THE ANGULAR VELOCITY CURVE FOR THE SWINGING FOLLOWER ARM may now be readily found and its acceleration and retardation judged. Let $S T$ represent the linear velocity of a point S at radius $A S$ on the cam. Then a point at B_4 on the working surface of the cam has a linear velocity of $S' T'$ and this value is laid off at $R_4 T_2$ where the point B_4 is in action. The component of $R_4 T_2$ that produces rotation in the swinging follower arm is $R_4 T_3$, perpendicular to $I R_4$, and this reduced to a radius of $I S_4$, equal to $A S$, for purpose of comparison with the cam rotation, is $S_4 T_4$. This value is laid

off on the 4th ordinate in the velocity diagram in Fig. 173, as at $S_4 T_4$. In a similar manner other values are obtained in Fig. 173 and the curve $B Q C$ drawn. This curve shows the rate of change of angular velocity in the transmitting follower arm while the straight horizontal line $D E$ shows the uniform angular velocity of the driving cam. The length $B C$ of the base line of the velocity diagram may be taken any length and then divided into six equal parts to locate the various ordinates of the velocity diagram. The length $D B$ in Fig. 173 equals $S T$ in Fig. 172.

437. THE AMOUNT OF SLIDING OF THE CAM may readily be found for example, by first breaking up the velocity $R_4 T_2$ of the point R_4 on the cam in Fig. 172 into its normal and tangential components—the former being shown at $R_4 T_5$ and the latter at $R_4 T_6$ —and, second, by breaking up the velocity $R_4 T_3$ of the corresponding point on the swinging arm into the components $R_4 T_5$ and $R_4 T_7$. The difference $T_6 T_7$, in the longitudinal components will be the rate of sliding at that phase and this difference is laid off at $S T$ in Fig. 174. Similarly other points on the curve $D T F$ are found. The rate of sliding when the circular surface of the cam $B F E$ is in action, providing there is no stop rest for the follower arm, is $B D$, equal to $S T$ in Fig. 172; and when the surface $C D$ is in action it is $C F$, Fig. 174.

438. A VELOCITY CURVE FOR THE FOLLOWER ROD $N N'$, Fig. 172, will give some indication of its acceleration and retardation and the relative strength of spring required to operate it in comparison with the results secured by an ordinary roller-end follower. The first step in this construction consists in finding the six positions of the center M of the upper curved surface $K' K''$ of the swinging arm. This is readily done because the points M , L and I are fixed relatively to each other, and, therefore, the point M_4 , for example, is found by taking $I M$ as a radius, I as a center, and drawing an arc at $M_0 M_6$. Then with $L M$ as a radius and L_4 as a center draw another short arc intersecting the first, as at M_4 . With $M K$ as a radius and M_4 as a center draw the arc passing through K_4 . The point K_4 is on a vertical line through M_4 . The horizontal line tangent to the arc at K_4 will have the position of the bottom of the follower rod at phase 4. In a similar way other points on the curve $K_0 K_6$ which is the locus of the point of tangency, is obtained. The distances between the horizontal lines drawn through the points K_0, K_1 , etc., will show the amount of vertical travel of the follower during each of the six equal time periods.

439. The velocity diagram for the vertical follower rod is quickly obtained by first laying off the same angular velocity for the swinging arm at K_4 , Fig. 172, as was found at R_4 and finding the vertical component of the velocity of the point K_4 . This is done in detail by taking the unit radius $I S_4$ together with the linear velocity $S_4 T_4$ at this unit radius, both of which have already been found, and trans-

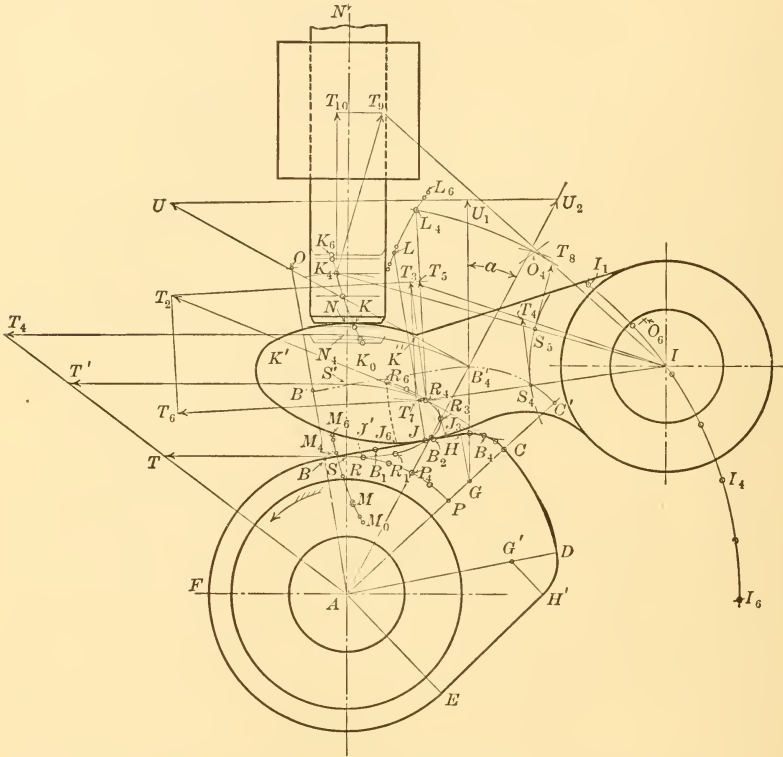

FIG. 172.—(Duplicate) SWINGING TRANSMITTER ARM WITH SLIDING ACTION

ferring the distance $S_4 T_4$ to $S_5 T_8$. This will represent the linear velocity of the point S_5 on the radial line $I K_4$. The resultant linear velocity of the contact point K_4 on the swinging arm is found, as shown, to be equal to $K_4 T_9$. The vertical component $K_4 T_{10}$ of this resultant velocity for the arm gives the actual upward velocity of the rod $N N'$. This value is laid off at $S T_{10}$ in Fig. 175 and is an ordinate on the velocity curve $B Q C$.

440. The corresponding ordinate $S U_3$, Fig. 175, for the velocity curve of the follower rod, if it had an ordinary roller end with a roller radius equal to $B B'$ of Fig. 172, may be found 1st, by drawing the pitch surface line $B' C'$ of the cam; 2d, by dividing the arc $B P$ into six equal parts; 3d, by drawing a radial line through the fourth point P_4 to B'_4 ; 4th, by revolving B'_4 to N_4 and obtaining the full linear velocity $N_4 T_4$ and laying it off at $B'_4 U$; 5th, by finding the radial velocity $B'_4 U_2$ by drawing the line $U U_2$ perpendicular to the normal $B'_4 U_1$. The length $B'_4 U_2$ will then represent the velocity of the follower bar if it had a roller end and this length is laid off at $S U_3$ in Fig. 175. Similarly other ordinates of the curve $B U_3 C$ are found.

441. COMPARING THE VELOCITIES OF THE FOLLOWER ROD $N N'$, Fig. 172, when a transmitting swinging arm is used and when an ordinary roller end is used, it will be seen that the follower rod attains a higher velocity in the former case as shown by the greater height of the curve $B Q C$ over the curve $B U_3 C$. Also the acceleration of the follower rod $N N'$ on the upstroke will be greater with the swinging arm as is indicated by the greater steepness of the curve from B to Q over that of the curve from B to U_3 .

442. THE SLIDING ACTION OF THE SURFACE $K' K''$, Fig. 172, of the swinging follower arm on the bottom of the rod $N N'$ has a maximum value of about one-fifth of that of the cam surface $B C$ on the lower face of the

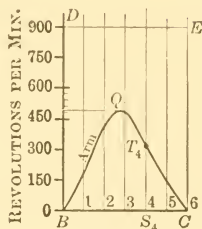

Fig. 173.

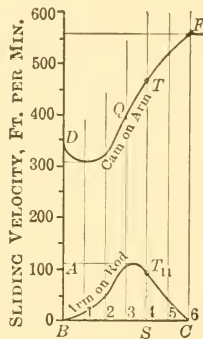

Fig. 174.

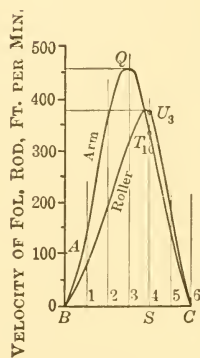

Fig. 175.

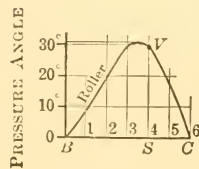

Fig. 176.

FIG. 173.—ANGULAR VELOCITY DIAGRAM FOR CAM AND SWINGING ARM

FIG. 174.—SLIDING VELOCITY DIAGRAM OF CAM ON SWINGING ARM AND OF ARM ON FOLLOWER ROD

FIG. 175.—LINEAR VELOCITY OF FOLLOWER ROD, WITH TRANSMITTING ARM AND WITH ORDINARY ROLLER FOLLOWER

FIG. 176.—PRESSURE ANGLE DIAGRAM, WITH ORDINARY ROLLER FOLLOWER

swinging arm. This is readily determined by making use of work already done, as, for example, by simply measuring the line $T_9 T_{10}$, in Fig. 172, which is the horizontal or sliding component of the resultant velocity $K_4 T_9$ when the point of driving contact is at K_4 . The distance $T_9 T_{10}$ is laid off at $S T_{11}$ in Fig. 174. Other points of the curve $B T_{11} C$ are found in the same way. The ordinates of this curve added to those of the curve $D T F$ would give a measure to the total sliding action at any instant when a swinging transmitting arm is used.

443. IF AN ORDINARY ROLLER FOLLOWER INSTEAD OF A SWINGING TRANSMITTING ARM WERE USED the pressure angle which would exist, with a cam of the size used in Fig. 172 and with a radius of roller equal to $B B'$, may also be readily determined from work already done. For example, when the center B'_4 of the roller is in action the roller will be pressing against the cam in the direction of the normal $B'_4 U_1$ relatively to the cam and the follower rod will be moving in the direction of the radial line $B'_4 U_2$ relatively to the cam. Therefore the pressure angle at phase 4 would be a , which is equal to 29° , and this value is laid off on the fourth ordinate as at $S V$ in Fig. 176, thus obtaining a point on the pressure angle curve which, it will be noted, has a maximum of about 31° —a very easy angle for general use.

444. IF IT IS DESIRED TO KNOW THE ACTUAL RUBBING VELOCITIES IN FEET PER MINUTE of the cam on the swinging arm, and of the arm on the follower rod; and the linear velocity of the follower rod $N N'$, Fig. 172, it may quickly be obtained from the velocity diagrams now drawn, for any given problem. For example, let it be assumed in this problem that the short radius $A B$ of the cam in Fig. 172 is $\frac{3}{4}$ inch and that the cam is making 900 revolutions per minute.

445. For the data just assumed the point B on the cam will be moving with a velocity of $\frac{.75 \times 2 \times 3.14 \times 900}{12} = 353$ feet per minute. This then would be the velocity represented by the line $S T$ in Fig. 172. Since all the velocity lines shown in the drawings have been found and laid down without any change in the scale of the drawing, it is only necessary to compute the distance on $S T$ that represents 100 feet per minute, and to make that distance the unit for the velocity scale for measuring the curves in Figs. 174 and 175. If $A S$ measures $\frac{3}{4}$ inch, $S T$ will be found to measure .98 inch to the same scale. Then .98 inch represents 353 feet per minute, or, in other words, .28 inch represents 100 feet per minute. In Figs. 174

and 175 the distance BA is .28 inch to the same scale on which AB was measured in Fig. 172, and this distance becomes the unit measurement for 100 feet per minute in the velocity diagrams.

446. By drawing the scales as above described it will be noted, in Fig. 174, that the maximum rubbing velocity of the cam on the lower face of the swinging arm is about 560 feet per minute and that the maximum rubbing velocity of the upper face of the swinging arm on the bottom of the follower rod is about 110 feet per minute. These considerations would affect the design in so far as lubrication and wear are concerned.

447. THE MAXIMUM VELOCITY OF THE FOLLOWER ROD NN' in Fig. 172, may also be read off directly in Fig. 175, after the scale has been laid down as above described. This maximum velocity, it will be noted, is about 460 feet per minute. Had an ordinary roller follower been used on the end of the follower rod, the maximum velocity of the rod would have been appreciably less, or about 380 feet per minute. This consideration has an important bearing on strength of the moving parts in the general design of cam work. Its comparative effect, as for example in the strength of spring required to return the follower parts, may be definitely obtained by constructing an acceleration and retardation diagram from the velocity curves shown in Fig. 175, as explained in detail in paragraph 268, *et seq.*

448. BOUNDARY OF SURFACE SUBJECT TO WEAR. In a cam design where there is a sliding follower as in Fig. 172 it will be of advantage to know not only the rubbing velocities as found above, but also the limits of the surfaces on which the rubbing takes place and the positions on the surfaces where the rubbing velocities are highest and the pressures due to acceleration are greatest. With respect to the cam in this problem, the conditions are ideal because the accelerations of the follower parts are greatest when the rubbing velocities are least. This combination occurs on the portion of the cam surface between B_1 and B_2 as may be pointed out as follows: (a) In Fig. 175 the velocity curve BQ is steepest between the phases 1 and 2 and consequently the acceleration of the follower rod NN' is greatest; (b), In Fig. 173 where the angular acceleration of the swinging arm is greatest also between 1 and 2; (c), and in Fig. 174 where the sliding velocity is lowest between 1 and 2. The conditions for the swinging arm I are not so good. In the first place the total wear on the lower surface of the arm on the upstroke takes place between J' and J_3 as

found by drawing the dashline arcs through the extremities R , R_3 and R_6 of the path of action taking I as a center in each case; secondly, the portion of the surface from J_6 to J_3 is rubbed over twice on the upstroke, or, in other words it receives twice as much wear as the part from J' to J_6 ; thirdly, the rubbing velocities are highest while the doubly worn surface from J_3 to J_6 is in action as indicated by the higher part of the curve from Q to F in Fig. 174; fourthly, the part of the swinging arm surface just to the right of J_6 is also under the most intense pressure, due to acceleration, as well as being subjected to double wear and high velocity, as may be noted by the fact that J_6 lies between the phases J_1 and J_2 and that between these phases the accelerations are greatest, as indicated by the steepness of the curves between the ordinates 1 and 2 in Figs. 173 and 175. The points J_1 and J_2 are not shown in Fig. 172, but they may be readily found by drawing arcs through R_1 and R_2 with I as a center. The point R_2 is on the path of action just above the point B_2 .

449. CAM ACTION DIFFERENT ON UP-AND-DOWN STROKES. All of the velocity and sliding curves obtained as above for the cam with a transmitting swinging arm, it will be noted, are for the action that takes place while the follower rod $N N'$, Fig. 172, is on its upstroke, or, in other words, while the part of the cam surface from B to C is in action. While the follower is on its downstroke the surface of the cam from D to E is in action and the velocity and the sliding curves will be different, and should be obtained by similar methods where full information for specific practical application is desired. It may easily happen, according to the forms of the acting faces of the swinging arm, that the velocities and the accelerations and retardations may be quite different on the two strokes. Hence the information regarding both strokes should be known in order to properly judge the friction and wearing characteristics, and also to judge the strength of parts to be used.

450. The disadvantage of the side pressure that accompanies the ordinary roller-end follower, and the disadvantage of the high rubbing velocity that accompanies the swinging transmitter arm which is illustrated at $I J K$ in Fig. 172, may be overcome by using a roller on the swinging arm to act against the surface BC of the cam, and a roller on the end of the follower arm to act on the transmitter head at $K' K''$. The side pressure produced by the slope of the cam is thus taken up by a tensional strain in the swinging arm instead of a side strain in the follower rod $N N'$, and a smoother and easier cam action

should result although there will be an increased number of parts in the cam mechanism.

451. PROBLEM 44. SMALL CAMS WITH SMALL PRESSURE ANGLES SECURED BY USING VARIABLE DRIVE. By giving the cam shaft a variable angular velocity very quick follower action may be secured with a relatively small cam without appreciably increasing the pressure angle. To illustrate, the same data will be taken as were used in Problem 3 except that the follower is to move up the given 3 units in 45° instead of 90° . The complete statement of the present problem is as follows: Required a single step radial cam to move a follower 3 units in 45° turn of the main shaft with uniform acceleration and retardation; to similarly return it in the next 45° , and to allow it to rest for the remainder of the cycle.

452. Let N , Fig. 177, be the center of the uniformly rotating main shaft of the machine to which the cam is to be applied. Assume any length for the driving arm NP and draw the two 45° angles $PN T$ and $T N Q$. Draw the circle whose radius is NP and divide each of the arcs PT and TQ into six equal parts. Connect the points Q and P , thus obtaining the point O on NT which will be the center of the auxiliary or cam shaft. Attach a slotted arm OH to the cam shaft, making the shorter working radius of the arm OJ equal to OT , and the longer working radius OH equal to ON plus NP . Assume the diameter of the driving pin at P which works in the slotted arm, and make the length of the slot a little greater than JH to allow for clearance.

453. VARIABLE DRIVE BY THE WHITWORTH MOTION. From the preceding paragraph it may now be seen that the arm OH , Fig. 177 and the cam shaft to which it is keyed will turn through 90° while the main machine shaft turns through 45° . The mechanism thus far described for producing this result is equivalent to the Whitworth slow-advance and quick-return mechanism, but any other type of slow-advance and quick-return mechanism that gives complete rotary motion could be used instead.

454. To construct the cam, compute the size of the pitch circle in the same manner as in an elementary problem, but using the 90° that the cam will turn during the outward motion of the follower instead of the assigned motion of 45° that the main shaft will turn. Thus the diameter of the pitch circle will be found to be,

$$\frac{3 \times 3.46 \times 360}{3.14 \times 90} = 13.2.$$

Lay this value off at $D S$, Fig. 177, and draw the pitch circle with O as a center. Lay off the assigned motion of 3 units of the follower symmetrically about D as at $A V$. Assuming 6 construction points for finding the cam pitch curve, divide $A D$ into nine equal parts and take the 1st, 4th and 9th division points; do the same with $V D$. Divide the arc $Q T$ into six equal parts and draw radial lines through each division point, as indicated at $O E$ and $O K$. Carry the division

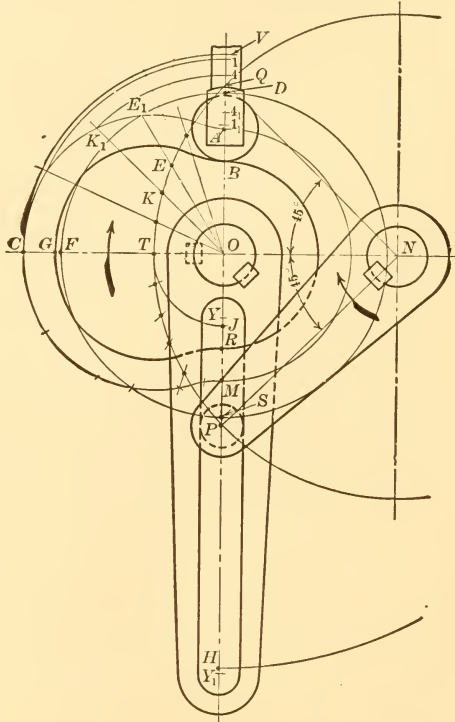

FIG. 177. PROBLEM 44, SHOWING THAT VERY SMALL CAMS AND SMALL PRESSURE ANGLES MAY BE OBTAINED BY USING VARIABLE VELOCITY DRIVE

points on $V A$ around to their corresponding radial lines by means of circular arcs, as indicated at $4 K_1$. Then the curve through the points A , K_1 , etc., will be on the pitch surface of the desired cam.

455. The present cam does the same work in half the time of the cam that is shown in Fig. 32, and both have the same overall dimensions. The cams are of different shape, however. The cam shaft O will have widely varying angular velocity, ranging between

values which vary from $\frac{1}{OJ}$ to $\frac{1}{OH}$. At the phase of the mechanism shown by the object lines in Fig. 177 the driving shaft N and the cam shaft O have the same angular velocity, and this is true for this phase no matter what length of driving arm is taken at the start. The cam will have its greatest angular velocity when NP is in the position NT , but at this phase the pressure angle will be zero, and it will be comparatively small while the cam is approaching and receding from this phase. Had a cam been constructed in

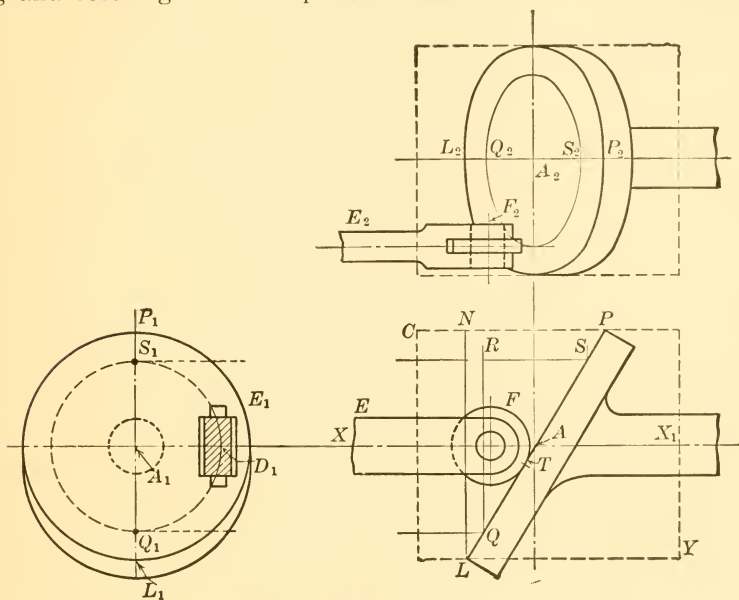

FIG. 178.—SWASH-PLATE CAM

the regular way, that is without variable drive of the cam shaft, to give 3 units motion in 45° under the condition of this problem it would have required a cam with a pitch circle diameter of

$$\frac{3 \times 3.46 \times 360}{3.14 \times 45} = 26.4$$

units instead of 13.2 as here used.

456. SWASH-PLATE CAMS differ in structural details from any thus far considered but they are, in effect, end or cylindrical cams. If in Fig. 178 a basic cylinder CY is intersected by an inclined plane PL it will cut a flat surface from the cylinder and the form

of this surface, when viewed perpendicularly, will appear as an ellipse in which the major and minor axes will be PL and NL , respectively. The flat surface thus formed is termed a swash plate. It is shown in the top view by the elliptical curve $P_2 L_2$ and in the end view by the circle $P_1 L_1$. As the swash plate turns on its axis XX_1 , which is the axis of the original cylinder it gives a reciprocating motion to a follower rod FE . The range of the follower motion will be greater or less according to the true radial distance $A_1 D_1$ of the follower from the axis of the cam, and in the present illustration the range of follower motion is RS . If a sharp V -edge were used on the follower EF , the contact would be at A , instead of at T as it is with the roller, and the motion of the follower would be harmonic, giving velocity and acceleration curves similar to those shown in Figs. 88 and 89 respectively. The smaller the follower roller FT , Fig. 178, the truer and smoother will be the running of the swash-plate cam.

457. ROTARY CAM GIVING INTERMITTENT ROTARY MOTION. A cam of unusual form is shown at AB in Fig. 179. It is designed to change a uniform rotary motion in the shaft PP to an intermittent rotary motion in the shaft C by operating on the roller pins D, E, F, G . Specifically, it is desired that the shaft C shall make a $\frac{1}{4}$ turn while the shaft PP makes a $\frac{1}{2}$ turn, then that the shaft C shall remain stationary while PP makes $\frac{1}{2}$ turn, and finally, that shaft C shall be under positive control all the time. Such a cam would be automatically formed on a previously prepared blank by using a rotary cutter of the same size as the rollers, D, E , etc., and which travels in the same path as the rollers while the cam blank is turned by independent means. For the purpose of laying out the blank and of representing the form of the cam surface in a drawing, the roller is taken in several intermediate positions, one of which is shown in fine lines at H , and constructions made as follows. The method here given is reduced to simplest terms and is approximate. It is sufficient, however, for the cam surface will be true, because of its automatic manufacture, even if the delineation is not exactly so.

458. Make an end view of the roller as shown at H_1 , Fig. 179. The circle through H_1 represents the circle half way down the roller and the short vertical line tangent to it locates the point of tangency for the cam surface and roller assuming that the cam surface has a 45° slant when the roller has turned 45° from E to H . Projecting H_1 first to H and then down to H_2 on the centerline, a point will

be found on the centerline of the cam surface, it being noted that the cam turns through 90° while the follower turns 45° . A straight line on the surface of the roller through H would represent approximately the line of contact between cam surface and roller and would be projected down to give K and N if the slant of the cam surfaces edges were the same. The slant for the edge $J K L$ of larger radius is a little less than that of $M N O$, being on a larger average radius, and, making a corresponding allowance, $H_2 K$ is taken a little less

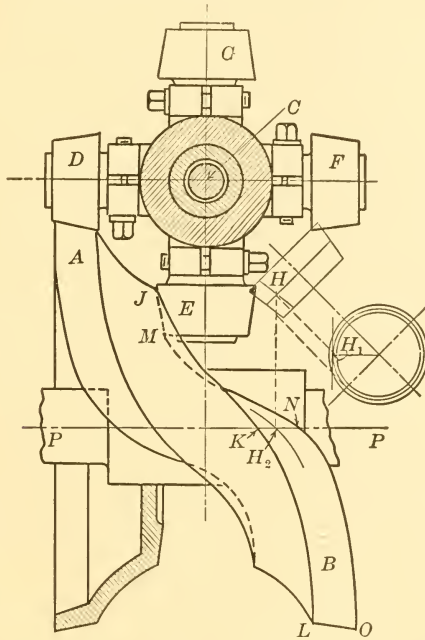

FIG. 179.—SPECIAL CAM TYPE GIVING INTERMITTENT ROTARY MOTION

than $H_2 N$. The points L and O will be directly under the roller in position F , and the distances from the centerline PP to these points will be the same as the distances from the centerline to the corresponding points on the bottom of the roller. It will be noted in this construction that the width of the cam surface is less than the length of the roller.

459. THE ECCENTRIC may be considered as a special type of cam. It is widely used in engine and other work where it is desired to secure a simple reciprocating motion from a rotary motion. Where

the initial motion may be taken from the end of a rotating shaft, a crank is the simpler device to use, but where the motion must be taken from an intermediate point on the shaft an eccentric is neces-

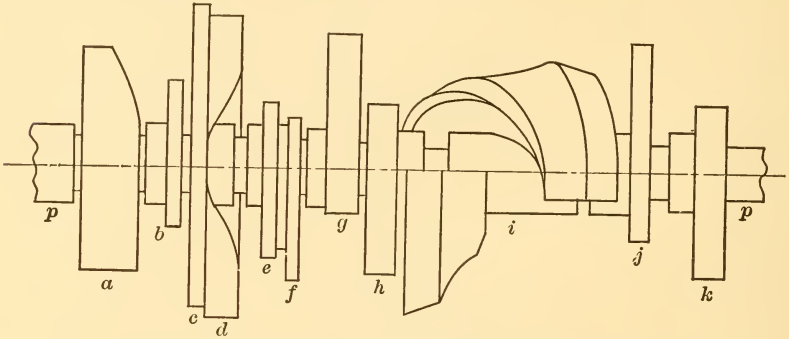

FIG. 180.—PRACTICAL EXAMPLE OF CAM SHAFT CARRYING ELEVEN CAMS

sary. The eccentric gives a characteristic motion to the follower the same as a driving crank would give to the crosshead in an ordinary crank and connecting-rod mechanism, the equivalent crank length being equal to the distance from the center of the shaft to the center

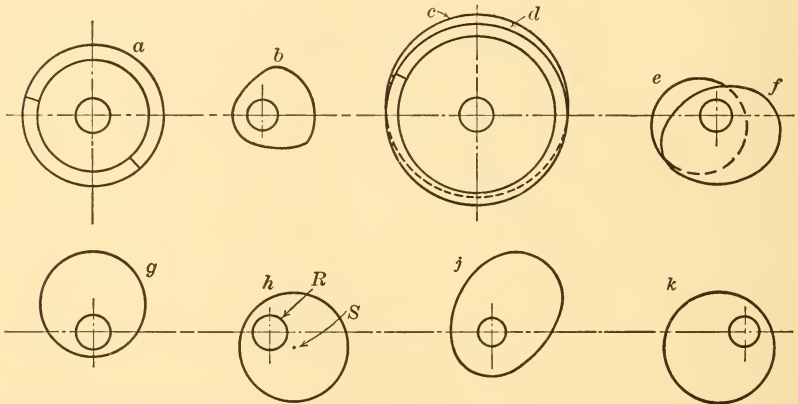

FIG. 181.—SEPARATE END VIEWS OF CAMS SHOWN IN FIG. 180, TO REDUCED SCALE

of the eccentric circle as shown at RS in Fig. 181. The eccentric cannot be used where specific intermediate velocities are desired for the follower. The use of the eccentric as a cam in automatic machinery is illustrated in Fig. 180 which represents the main cam shaft of a machine devised for special manufacturing purposes. Eleven cams,

compactly arranged, are shown on this shaft, four of them being eccentrics, namely Nos. *e*, *g*, *h*, and *k*. All eleven cams are shown in end view in Fig. 181 with the exception of *i*, which is shown to enlarged scale in Fig. 179.

460. AN EXAMPLE OF A TIME-CHART DIAGRAM for all of the cams illustrated in Figs. 180 and 181 is given in Fig. 182. Time-chart

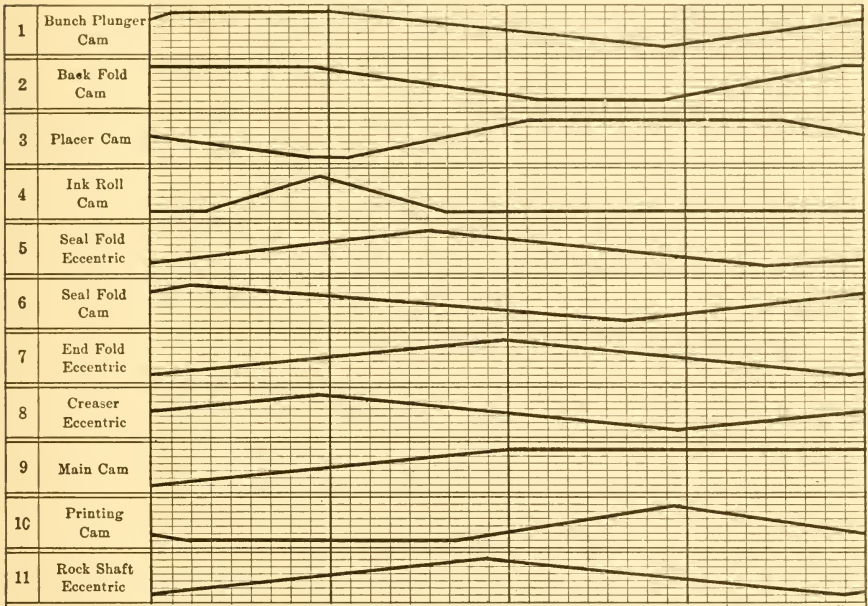

FIG. 182.—PRACTICAL EXAMPLE OF TIME CHART DIAGRAM FOR ELEVEN CAMS IN ONE AUTOMATIC MACHINE

diagrams are treated in a general way in paragraph 19, and in detail with reference to a specific example in paragraphs 143 to 147. The form of diagram here shown is specially to be commended in that the individual diagram boxes for each cam are separated from each other by a small space so that it is impossible for the heavy base lines to touch or cross each other under any circumstances.



INDEX

| | A | PAGE | PAGE | PAGE |
|--|---|----------|---|------------|
| Acceleration diagrams for different base curves..... | | 89 | Cam factors. Method of determining..... | 152 |
| Acceleration diagrams. Method of determining..... | | 138 | Cam mechanism for drawing ellipse..... | 79 |
| Accelerations produced by different base curves..... | | 142 | Cam mechanism for reproducing designs..... | 80 |
| Accuracy in cam construction.... | | 146 | Cam shaft acting as guide..... | 204 |
| Adjustable cam defined..... | | 11 | Cam size. Effect on pressure angle..... | 33 |
| Adjustable cylindrical cam plates.. | | 193 | Cam surface on follower..... | 208, 213 |
| All-logarithmic base curve..... | | 89 | Cam with flat-surface follower.... | 45 |
| All-logarithmic cam problem..... | | 94 | Cam with sliding follower..... | 57 |
| Angular velocity curve for swinging follower..... | | 216 | Cams classified..... | 1 |
| | B | | Cams for high-speed work..... | 148 |
| Balancing of cams..... | | 148 | Cams for low-starting velocities | 129, 132 |
| Barrel cam defined..... | | 7 | Cams for swinging follower arms | 50, 52, 57 |
| Base curve defined..... | | 14 | Carrier cam defined..... | 11 |
| Base curves in common use..... | | 14 | Characteristics of base curves.... | 88 |
| Base curves. Comparison of.... | | 88 | Circles. Subdivision of..... | 86 |
| Base curves. Complete list of.... | | 88 | Circular base curve. Case I..... | 119 |
| Base curves. Construction of common..... | | 20 | Circular cam problem. Case II... | 129 |
| Base line defined..... | | 14 | Clamp cam defined..... | 11 |
| Box cam defined..... | | 8 | Comparison of base curves..... | 88 |
| | C | | Comparison of parabola and crank curves..... | 111 |
| Cam action different in up-and-down strokes..... | | 160, 222 | Comparison of velocities and forces of different base curves..... | 141 |
| Cam chart applied..... | | 29 | Conical cams defined..... | 2 |
| Cam chart defined..... | | 12 | Conical follower pin for cylindrical cam..... | 190 |
| Cam chart diagram defined..... | | 12 | Construction of common base curves..... | 20 |
| Cam considered as bent chart.... | | 34 | Crank curve as projection of helix.. | 108 |
| Cam defined..... | | 1 | Crank curve characteristics... | 108, 111 |
| Cam factor chart for all base curves..... | | 151 | Crank curve construction..... | 21 |
| Cam factor chart for common base curves..... | | 19 | Cube base curve..... | 125 |
| Cam factors for all base curves.... | | 150 | Cube curve cam problem. Case I. | 127 |
| Cam factors for common base curves..... | | 18 | Cube curve cam problem. Case II..... | 133 |

| | PAGE | | PAGE |
|---|---------|--|------------|
| Cube curve cam specially adapted for follower returned by spring | 144 | Flat-surface follower..... | 45, 49, 59 |
| Curved follower toe..... | 162 | Follower carrying cam surface..... | 208, 213 |
| Cylindrical cam defined..... | 1, 7 | Follower returned by springs..... | 142 |
| Cylindrical cam problem..... | 68, 70 | Follower rollers for cylindrical cams..... | 188 |
| Cylindrical cams. Drawing of grooves in..... | 186 | Follower roller. Size of..... | 35 |
| Cylindrical cams. True pressure angle in..... | 186 | Follower velocity in ft. per sec. | 165, 220 |
| D | | | |
| Derived curve for pure rolling action..... | 174 | Follower with curved toe..... | 162 |
| Diagram. Cam chart..... | 12 | Forces produced by different base curves..... | 141 |
| Diagram. Timing..... | 13 | Formula for cam size..... | 17 |
| Disk cam defined..... | 1 | Frog cam defined..... | 2 |
| Dog cam defined..... | 11 | G | |
| Double-acting cam defined..... | 9 | Gradual starting of follower shaft.. | 177 |
| Double-disk positive drive cam for swinging arms..... | 205 | Graphical methods. Degree of precision in..... | 141 |
| Double-disk yoke cam problem.... | 65 | Gravity curve..... | 110 |
| Double-end cam defined..... | 7 | Groove cam defined..... | 7 |
| Double-mounted cam defined.... | 11 | H | |
| Double-screw cams..... | 194 | Handwriting. Cam mechanism for reproducing..... | 79 |
| Double-step radial cam..... | 39 | Harmonic curve..... | 108 |
| Drum cam defined..... | 7 | Harmonic motion..... | 108, 206 |
| E | | | |
| Eccentric as a cam..... | 227 | Heart cam defined..... | 3 |
| Ellipse. Cam mechanism for drawing of..... | 79 | Helix as projection of crank curve.. | 108 |
| Ellipse. Construction of..... | 178 | High speed in cam work..... | 148 |
| Elliptical arcs for pure rolling action..... | 177 | Hyperbola for pure rolling action. | 184 |
| Elliptical base curve character- istics..... | 123 | Hyperboloidal follower pin for cylindrical cam..... | 190 |
| Elliptical curve construction..... | 23 | I | |
| Empirical cam design..... | 25 | Infinite connecting rod..... | 108 |
| End cam defined..... | 7 | Interference of cams..... | 75 |
| F | | | |
| Face cam defined..... | 3 | Intermediate transmitter arm.... | 214 |
| Face cam problem..... | 55 | Intermittent harmonic motion.... | 206 |
| Factors. Methods of determining cam..... | 152 | Intermittent rotary motion..... | 226 |
| Factors. Table of cam..... | 18, 150 | Internal cam defined..... | 8 |
| | | Involute cam problem..... | 199 |
| | | Involute curve defined..... | 197 |
| | | Involute curve. Construction of. | 192 |
| | | K | |
| | | Keyways. Location of..... | 78 |

| L | PAGE | | PAGE |
|--|-----------------------|---|--------------|
| Length of follower surface | 58, 62, 159, 164 | Pitch line defined | 15 |
| Limited use of flat-surface followers | 49, 59 | Pitch point defined | 16 |
| Limited use of single-disk yoke cams | 64 | Pitch surface defined | 16 |
| Limiting size of follower roller | 35 | Plate cam defined | 3 |
| Locus of point of contact between cam and follower | 58, 62, 159, 164, 216 | Plates for cylindrical cams | 193 |
| Logarithmic-combination cam problem | 101 | Positive-drive cam defined | 8 |
| Logarithmic curve. Construction of | 101, 172 | Positive-drive double-disk cam for swinging arms | 205 |
| Logarithmic curve for pure rolling action | 169, 171 | Positive-drive single-disk cam for swinging arms | 202 |
| Logarithmic curve. Properties of | 171 | Precision of graphical methods | 141 |
| Logarithmic spiral. Construction of | 95, 98 | Pressure angle characteristics of involute curve | 198, 201 |
| | | Pressure angle defined | 16 |
| | | Pressure angle factors | 18, 149, 150 |
| | | Pressure angle relation to cam size | 31 |
| | | Pure rolling in cam work | 168-185 |
| | | | |
| | | R | |
| | | Radial cam defined | 1 |
| | | Radius of curvature of non-circular arcs | 38 |
| | | Rate of sliding of cam on surface of follower | 164, 166 |
| | | Regulation of noise in cam design | 147 |
| | | Relative strengths of springs required for different cams | 143 |
| | | Roller. Limiting size of | 35 |
| | | Rollers for cylindrical cams | 188 |
| | | Rolling action | 168-185 |
| | | Rolling cam defined | 5 |
| | | Rotary cam giving intermittent rotary motion | 226 |
| | | Rotary sliding-disk yoke cam | 205, 206 |
| | | | |
| | | S | |
| | | Scotch yoke | 207 |
| | | Screw cams | 193 |
| | | Shaft guide for cam followers | 204 |
| | | Side cam defined | 1 |
| | | Sine curve | 108 |
| | | Single-acting cam defined | 9 |
| | | Single-disk positive drive cam for swinging arms | 202 |
| | | Single-disk yoke cam problem | 63 |
| | | Single-step cam problem | 28, 31 |
| | | Sinusoid | 108 |

L

PAGE

PAGE

| M | |
|--|-----|
| Multiple-mounted cam defined | 11 |
| Mushroom cam defined | 3 |
| Mushroom cam problem | 45 |
| | |
| N | |
| Names of cams tabulated | 12 |
| Noise from cams | 147 |
| | |
| O | |
| Offset cam defined | 8 |
| Offset cam problem | 42 |
| Omission of cam chart | 31 |
| Oscillating cam defined | 11 |
| Oscillating single-disk positive-drive cam | 202 |

P

| | |
|----------------------------------|---------|
| Parabola cam characteristics | 110 |
| Parabola construction | 22, 182 |
| Parabola for pure rolling action | 182 |
| Parabolic easing-off arcs | 103 |
| Parabolic curve. Property of | 182 |
| Perfect cam action | 110 |
| Periphery cam defined | 2 |
| Pins for cylindrical cams | 188 |
| Pitch circle defined | 16 |

| | |
|--|--------------|
| Pitch line defined | 15 |
| Pitch point defined | 16 |
| Pitch surface defined | 16 |
| Plate cam defined | 3 |
| Plates for cylindrical cams | 193 |
| Positive-drive cam defined | 8 |
| Positive-drive double-disk cam for swinging arms | 205 |
| Positive-drive single-disk cam for swinging arms | 202 |
| Precision of graphical methods | 141 |
| Pressure angle characteristics of involute curve | 198, 201 |
| Pressure angle defined | 16 |
| Pressure angle factors | 18, 149, 150 |
| Pressure angle relation to cam size | 31 |
| Pure rolling in cam work | 168-185 |

R

| | |
|---|----------|
| Radial cam defined | 1 |
| Radius of curvature of non-circular arcs | 38 |
| Rate of sliding of cam on surface of follower | 164, 166 |
| Regulation of noise in cam design | 147 |
| Relative strengths of springs required for different cams | 143 |
| Roller. Limiting size of | 35 |
| Rollers for cylindrical cams | 188 |
| Rolling action | 168-185 |
| Rolling cam defined | 5 |
| Rotary cam giving intermittent rotary motion | 226 |
| Rotary sliding-disk yoke cam | 205, 206 |

S

| | |
|--|--------|
| Scotch yoke | 207 |
| Screw cams | 193 |
| Shaft guide for cam followers | 204 |
| Side cam defined | 1 |
| Sine curve | 108 |
| Single-acting cam defined | 9 |
| Single-disk positive drive cam for swinging arms | 202 |
| Single-disk yoke cam problem | 63 |
| Single-step cam problem | 28, 31 |
| Sinusoid | 108 |

| | PAGE | | PAGE |
|--------------------------------------|---------|------------------------------------|-----------------------|
| Sliding contact follower..... | 57 | Time-chart diagram for eleven | |
| Sliding friction eliminated..... | 168 | cams..... | 229 |
| Sliding of cam on follower surface, | | Time-distance diagrams..... | 138 |
| 164, 166, | 219 | Time-velocity diagrams..... | 138 |
| Slow-advance and quick-return by | | Timing of cams. Problem..... | 75 |
| cylindrical cams..... | 195 | Toe-and-wiper cam defined..... | 7 |
| Small cams with small pressure | | Toe-and-wiper cam problem..... | 61 |
| angles secured by variable | | Toe-and wiper cam with variable | |
| speed drive..... | 223 | angular velocity..... | 157 |
| Spherical cam defined..... | 2 | Transmitter arm between cam and | |
| Springs. Use of, for returning | | follower..... | 214 |
| cam followers..... | 142 | | |
| Starting velocities of cam followers | | V | |
| 129, | 132 | Variable angular velocity in cam | |
| Step cam defined..... | 9 | shaft..... | 157 |
| Straight-line base curve construc- | | Variable speed for small cams.... | 223 |
| tion..... | 20 | Varied forms of fundamental base | |
| Straight-line base curve problem. | 106 | curves..... | 111, 149 |
| Straight-line combination base | | Velocities produced by different | |
| curve construction..... | 20, 107 | base curves..... | 141 |
| Straight-sliding plate cams..... | 196 | Velocity diagrams for different | |
| Strap cam defined..... | 11 | base curves..... | 89 |
| Subdivision of circles..... | 86 | Velocity diagrams. Method of | |
| Subtangent of logarithmic curve... | 102 | determining..... | 138 |
| Swash plate cam..... | 225 | Velocity of follower in feet per | |
| Swinging follower arm..... | 50 | second..... | 165, 220 |
| Swinging transmitter arm..... | 214 | | |
| | | W | |
| T | | Wear. Distribution of, on follower | |
| Table of cam factors for all base | | surface..... | 58, 62, 159, 164, 221 |
| curves..... | 150 | Whitworth motion..... | 223 |
| Tangential base curve..... | 113 | Wiper cam defined..... | 5 |
| Tangential cam problem. Case I. | 113 | Working surface defined..... | 16 |
| Tangential cam problem. Case | | | |
| II..... | 135 | Y | |
| Technical cam design..... | 27 | Yoke cam defined..... | 6 |
| Time-acceleration diagrams..... | 139 | Yoke cam with rotary sliding disk | 206 |
| Time chart applied..... | 76 | Yoke cam problem. Double-disk. | 65 |
| Time chart defined..... | 13 | Yoke cam problem. Single-disk.. | 63 |



Wiley Special Subject Catalogues

For convenience a list of the Wiley Special Subject Catalogues, envelope size, has been printed. These are arranged in groups—each catalogue having a key symbol. (See special Subject List Below). To obtain any of these catalogues, send a postal using the key symbols of the Catalogues desired.

-
- 1—Agriculture. Animal Husbandry. Dairying. Industrial Canning and Preserving.**
 - 2—Architecture. Building. Concrete and Masonry.**
 - 3—Business Administration and Management. Law. Industrial Processes: Canning and Preserving; Oil and Gas Production; Paint; Printing; Sugar Manufacture; Textile.**

CHEMISTRY

- 4a** General; Analytical, Qualitative and Quantitative; Inorganic; Organic.
- 4b** Electro- and Physical; Food and Water; Industrial; Medical and Pharmaceutical; Sugar.

CIVIL ENGINEERING

- 5a** Unclassified and Structural Engineering.
 - 5b** Materials and Mechanics of Construction, including; Cement and Concrete; Excavation and Earthwork; Foundations; Masonry.
 - 5c** Railroads; Surveying.
 - 5d** Dams; Hydraulic Engineering; Pumping and Hydraulics; Irrigation Engineering; River and Harbor Engineering; Water Supply.
-
-

CIVIL ENGINEERING—Continued

5e Highways; Municipal Engineering; Sanitary Engineering; Water Supply. Forestry. Horticulture, Botany and Landscape Gardening.

6—Design. Decoration. Drawing: General; Descriptive Geometry; Kinematics; Mechanical.

ELECTRICAL ENGINEERING—PHYSICS

7—General and Unclassified; Batteries; Central Station Practice; Distribution and Transmission; Dynamo-Electro Machinery; Electro-Chemistry and Metallurgy; Measuring Instruments and Miscellaneous Apparatus.

8—Astronomy. Meteorology. Explosives. Marine and Naval Engineering. Military. Miscellaneous Books.

MATHEMATICS

9—General; Algebra; Analytic and Plane Geometry; Calculus; Trigonometry; Vector Analysis.

MECHANICAL ENGINEERING

10a General and Unclassified; Foundry Practice; Shop Practice.

10b Gas Power and Internal Combustion Engines; Heating and Ventilation; Refrigeration.

10c Machine Design and Mechanism; Power Transmission; Steam Power and Power Plants; Thermodynamics and Heat Power.

11—Mechanics.

12—Medicine. Pharmacy. Medical and Pharmaceutical Chemistry. Sanitary Science and Engineering. Bacteriology and Biology.

MINING ENGINEERING

13—General; Assaying; Excavation, Earthwork, Tunneling, Etc.; Explosives; Geology; Metallurgy; Mineralogy; Prospecting; Ventilation.

14—Food and Water. Sanitation. Landscape Gardening. Design and Decoration. Housing, House Painting.







LIBRARY OF CONGRESS



0 021 213 119 2