

complete
in itself

G. K. M. from W. E. M.

August 2nd 1895.

Clarendon Press Series

ASTRONOMY.

CHAMBERS.

II.

INSTRUMENTS AND PRACTICAL ASTRONOMY.

London
HENRY FROWDE



OXFORD UNIVERSITY PRESS WAREHOUSE
AMEN CORNER, E.C.



Woodburytype.

[Oxford University Press.

THE NEW 30-INCH REFRACTOR OF THE PULKOWA OBSERVATORY.

Constructed by REPSOLD AND SONS, Hamburg, 1884.

A HANDBOOK OF DESCRIPTIVE AND PRACTICAL ASTRONOMY.

BY

GEORGE F. CHAMBERS, F.R.A.S.,

OF THE INNER TEMPLE, BARRISTER-AT-LAW;

*Author of "A Practical and Conversational English, French, and German Dictionary;"
"The Tourist's Pocket-Book;" "A Digest of the Law relating to Public
Health;" "A Digest of the Law relating to Public Libraries
and Museums;" "A Handbook for Public Meetings;"
and other Works.*

"The Lord by wisdom hath founded the earth; by understanding hath He established
the heavens."—*Prov. iii. 19.*

II.

INSTRUMENTS AND PRACTICAL ASTRONOMY.

FOURTH EDITION.

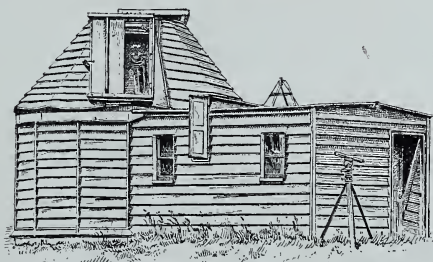

OBSERVATORY ERECTED AT EAST-BOURNE, 1854.

Oxford:

AT THE CLARENDON PRESS.

1890.

[All rights reserved.]

Oxford

PRINTED AT THE CLARENDON PRESS

BY HORACE HART, PRINTER TO THE UNIVERSITY

PREFACE TO THE FOURTH EDITION.

FOR a full explanation of the circumstances in virtue of which the matter forming the contents of this volume now appears dissociated from that to which it was joined in the first three editions of this work the reader is referred to Vol. I. of the 4th edition, published in September, 1889. Suffice it therefore now to state briefly what has been done to render the contents of this volume as acceptable as possible to the public.

The chapters relating to the telescope have been to a large extent re-written, and where they have not been re-written, they have been thoroughly revised and very extensively added to. But by far the most important change made in Book VII. ("Practical Astronomy") has been the prominence given to the construction and equipment of observatories. The multiplication of telescopes of all sizes during recent years has made the question of housing them one of much greater interest and importance than it was half, or even a quarter, of a century ago. I have endeavoured to meet this new condition of things not only by giving information derived from my own experience, but by accepting professional help from professional friends. I attach therefore very great importance to the lithographic plans and specifications for small observatories kindly prepared for me by Mr. *F. Brodie* and Mr. *T. R. Clapham*. If these plans are found to be generally appreciated (as I feel sure will be the case), probably one or two more will be added in a future edition.

The allusion made to Admiral *Smyth* in the Preface of Vol. I. has also some applicability to the present volume, which will be found to include certain extracts from the *Prolegomena* of his "Bedford Catalogue," including also sundry wood-cuts which originally appeared there.

To Mr. *E. W. Maunder* of the Royal Observatory, Greenwich, I owe, as in 1877, the chapters on Astronomical Spectroscopy; but they have been almost entirely rewritten, and much added to. So far as the space allotted to them permits they furnish a complete and comprehensive summary of the subject to which they relate. Mr. *Maunder* has also rewritten the "Book" which deals with Astronomical Photography.

All the remaining portions of the volume have been revised and added to as necessity seemed to suggest, but it is not worth while to state in detail the alterations made.

With regard to the List of books, however, it may be remarked that I have revised it with the co-operation of friends; and I shall always be glad to receive suggestions calculated to make it more useful and trustworthy.

Various chapters have undergone the scrutiny of my old friend Capt. *W. Noble*, and in reading for press the whole work I have been assisted as before by the Rev. *J. B. Fletcher* and Mr. *W. T. Lynn*.

For many of the engravings I am indebted to the kindness of the Secretaries of the *Royal Astronomical Society*, to the proprietors of the *Observatory*, to Sir *H. Grubb*, Messrs. *Cooke & Co.*, and others, not forgetting MM. *Gauthier Villars*, *Secrétan* and *Bardou* of Paris, and several friends in America.

G. F. C.

NORTHFIELD GRANGE,
EAST-BOURNE, SUSSEX :
March, 1890.

CONTENTS.



BOOK VII.

PRACTICAL ASTRONOMY.

CHAPTER I.

THE TELESCOPE AND ITS ACCESSORIES.

Two kinds of telescopes.—Reflecting telescopes.—The Gregorian reflector.—The Cassegrainian reflector.—The Newtonian reflector.—The Herschelien reflector.—Lord Rosse's large reflector.—Nasmyth's reflector.—Browning's mountings for reflectors.—Adjustment of reflectors.—Refracting telescopes.—Refractors and reflectors compared.—Spherical aberration.—Chromatic aberration.—Tests for both.—Theory of Achromatic combinations.—Tests of a good object-glass.—The Dialyte.—The Galilean refractor.—Eye-pieces.—The positive eye-piece.—The negative eye-piece.—Formulæ for calculating the focal lengths of equivalent lenses.—Kellner's eye-piece.—The Barlow lens.—The Terrestrial eye-piece.—The Pancratic Terrestrial eye-piece.—Grubb's Prismatic Terrestrial eye-piece.—Ramsden's Dynamometer.—Berthon's Dynamometer.—Dawes's rotating eye-piece.—The diagonal eye-piece.—Dawes's solar eye-piece.—Hilger's solar eye-piece.—The Polarising eye-piece.—Airy's eye-piece for atmospheric dispersion.—Micrometers.—The reticulated micrometer.—The parallel-wire micrometer.—The position micrometer.—Measurement of angles of position.—Grubb's Duplex micrometer.—Bright-wire micrometer.—Bidder's micrometer.—Burnham's micrometer.—The Double image micrometer.—The Ring micrometer.—The Square-Bar micrometer.—The Zone Reticle.—Slipping-piece.—Telescopic tubes. Pages 1-47

CHAPTER II.

TELESCOPE STANDS.

Importance of having a good Stand.—“Pillar-and-Claw” Stand.—The “Finder.”—Vertical and Horizontal Rack Motions.—Steadying Rods.—Cooke's Mounting.—Varley's Stand.—Proctor's Stand.—Altazimuth stands for reflectors.—Brett's Altazimuth mounting for reflectors.—Other forms of Altazimuth stands.—Interchangeable Altazimuth and Equatorial stands.—Smeaton's block. 48-63

CHAPTER III.

THE EQUATORIAL.

Brief epitome of the facts connected with the apparent rotation of the Celestial Sphere.—Principle of the Equatorial Instrument.—Lord Crawford's plan for converting an Altazimuth into an Equatorial.—Two forms in general use.—Description of Sisson's form, and of the different accessories to the instrument generally.—Description of Fraunhofer's form of Equatorial.—In what its superiority consists.—Types of Modern Equatorials of English, German and American manufacture.—Portable Equatorial Mountings.—Erck's Window Equatorial.—Equatorial mountings for Reflectors.—Universal Equatorial.—The adjustments of the Equatorial six in number.—Method of observing with the instrument, reading the Circles, &c.—Examples. 64-117

CHAPTER IV.

THE TRANSIT INSTRUMENT.

Its importance.—Description of the Portable Transit.—Adjustments of the Transit.—Four in number.—Method of performing them.—Example of the manner of recording Transit observations of Stars.—Of the Sun.—Remarks on observations of the Moon.—Of the larger Planets.—Mode of completing imperfect sets of Transit observations.—The uses to which the Transit Instrument is applied. 118-148

CHAPTER V.

THE SEXTANT.

Description of the instrument.—The optical principle on which it depends.—Its adjustments.—Corrections to be applied to observations made with it.—Method of finding the Sun's zenith distance.—The artificial horizon.—To find the latitude.—To determine the time. 149-163

CHAPTER VI.

MISCELLANEOUS ASTRONOMICAL INSTRUMENTS.

The Altazimuth.—Everest's Theodolite.—The Mural Circle.—The Repeating Circle.—Troughton's Reflecting Circle.—The Dip-Sector.—The Zenith-Sector.—The American Zenith-Sector.—The Reflex Zenith-Tube.—The Horizontal Floating Collimator.—The Vertical Floating Collimator.—The Heliometer.—Airy's Orbit-Sweeper.—The Comet-Seeker.—The Astronomical Spectroscope. 164-192

CHAPTER VII.

THE OBSERVATORY.

Introductory statement.—The Bedford Observatory.—Choice of a site.—Foundations.—Details of the structure of the Observatory.—The Equatorial Room. Construction of Domes.—Hemispherical Dome.—Drum Dome.—Polygonal Dome.—Bearings for a Dome.—Cannon Balls.—Movement of a Dome.—Transit Room.—Transit Room arrangements at Bedford.—Setting Circles.—Meridian Mark.—Observatory Clocks.—Hardy's Noddy.—Observing Seats and Chairs.—Dawes's Chair.—Cooke's Observatory ladder.—Ladder at the Dearborn Observatory.—Knobel's Observing Chair.—Plans and specifications for a 10-ft. Observatory.—Adaptation of the same to a private house.—The "Romsey" form of cheap Observatory.—Plans and specifications of the same.—The 30-ft. Lassell Dome at the Royal Observatory, Greenwich.—The Washburn Observatory, Madison, U.S.—The Lick Observatory, Mount Hamilton, California. 193-241

CHAPTER VIII.

PRACTICAL HINTS ON THE CONDUCT OF ASTRONOMICAL OBSERVATIONS.

On the choice of Instruments.—Eye-pieces.—Areas of Object-glasses and Mirrors.—On cleaning Lenses and Mirrors.—On the choice of stands.—Clockwork.—The Parallax Ladder.—Observing-box.—Steinheil's Transit Prism.—Sidereal Time Indicator.—Useful Books.—How to observe the Sun.—The Moon.—The Planets.—Sweeping for Objects.—Comets, Clusters, and Nebulæ.—Drawing nebulæ.—Stars, including Double Stars.—Triangular Star Discs.—Observations of Stars for colour.—Magnitudes of Stars.—Observations of Variable Stars.—Miscellaneous Hints.—Lights in an Observatory.—Clothing for an Observer.—Number of nights available in a year.—Aperture of Object-glass may sometimes be reduced with advantage.—Forms to facilitate work at the Telescope.—Hints by Admiral Smyth. 242-290

CHAPTER IX.

HISTORY OF THE TELESCOPE.

Early history lost in obscurity.—Vitello.—Roger Bacon.—Dr. Dec.—Digges.—Borelli's endeavour to find out who was the inventor.—His verdict in favour of Janssen and Lippersheim of Middleburg.—Statements by Boreel.—Galileo's invention.—Scheiner's use of two double-convex Lenses.—Lenses of long focus used towards the close of the 17th century.—Invention of Reflectors.—Labours of Newton.—Of Halley.—Of Bradley and Molyneux.—Of Mudge.—Of Sir W. Herschel.—Of the Earl of Rosse.—Of Mr. Lassell.—Improvements in Refracting Telescopes.—Labours of Hall.—Of Euler.—Of the Dollonds.—The largest Refractors yet made. 291-297

BOOK VIII.

SPECTROSCOPIC ASTRONOMY.

CHAPTER I.

INTRODUCTORY.

- A New Department of Astronomy.—“Celestial Chemistry.”—Outline of the History of the Recognition of the Solar Spectrum.—Explanation of the Dark Lines.—The three Orders of Spectra.—Variations in the width and in the refrangibility of lines. 298–307

CHAPTER II.

SPECTROSCOPY AS APPLIED TO THE SUN.

- Elements recognised in the Sun.—The Telluric lines.—Researches of Janssen and Egoroff.—Cornu’s device.—The Rainband.—Spectra of Sun-spots.—Observations at Greenwich, Stonyhurst and South Kensington.—Behaviour of iron lines.—Lockyer’s dissociation theory.—Spectra of Faculæ, Pores and Granules.—Spectra of Prominences.—Method for observing them in full sunshine.—Their systematic observation.—Connection with spots and faculæ.—Spectrum of the Chromosphere.—Spectrum of the Corona.—Its threefold character.—Spectrum of the Zodiacal Light. 308–338

CHAPTER III.

SPECTROSCOPY AS APPLIED TO PLANETS AND COMETS.

- Spectrum of the Moon.—Traces of atmospheric absorption in Mars.—Spectrum of the eclipsed Moon.—Spectra of Jupiter and Saturn.—Spectrum of Uranus.—Taylor’s observation of bright lines.—Spectrum of Neptune.—Of the Rings of Saturn.—Spectra of Comets.—The ordinary type.—The Comets of Tebbutt and Schæberle.—Wells’s Comet.—The Great Comet of 1882.—Spectra of Meteors.—Lockyer’s researches on the spectra of Meteorites. ... 339–351

CHAPTER IV.

SPECTROSCOPY AS APPLIED TO STARS AND NEBULÆ.

- Elements discovered in Stellar Spectra.—Types of Spectra.—Secchi’s classification.—Brighter Stars of the different Types.—Vogel’s classification.—Lockyer’s.—Relation of the three methods.—Bright-line Spectra.—Temporary Stars.—T Coronæ.—Nova Cygni, 1876.—Nova Andromedæ, 1885.—Spectra of Nebulæ.—Connection with Meteorites.—Motions of Stars in the line of sight.—Comparison of results obtained at different Observatories.—Motion of Sirius.—Observations of Algol. 352–378

CHAPTER V.

MAPS OF THE SPECTRUM.

Kirchhoff's Map of the Solar Spectrum.—Advantages of a diffraction grating.—Ångström's Normal Spectrum.—Wave-lengths of the principal Fraunhofer lines.—Reduction of Measures.—Maps of the Spectrum.—Rowland's Photographs.—The Ultra-violet Spectrum.—Huggins's Photographs of Stellar Spectra, and of the Spectra of Nebulæ and Comets.—Fluorescence.—The Infra-red Spectrum.—Phosphorescence.—Abney's Photographs of the Infra-red.—Langley's Bolometer.—Entire range of the Spectrum. ... 379-389

BOOK IX.

ASTRONOMICAL PHOTOGRAPHY.

HISTORICAL SURVEY.

Three stages of Astronomical Photography.—The Daguerreotype.—The Collodion and Gelatine processes.—Advantage of Reflectors for Photography.—Adaptation of Refractors.—Solar Photography.—The two forms of Photoheliograph.—Transits of Venus.—Total Solar Eclipses.—Lunar Photography and Libration.—The first photographs of Nebulæ and Comets.—Pickering's determination of Stellar Magnitudes by Photography.—Espin's.—The Brothers Henry.—Photograph of the Pleiades.—Roberts's photographs of Nebulæ.—The Photographic Congress.—The Cape Photographic Durchmusterung.—Photography at the Paris Observatory.—Stellar Parallax.—Observation of Meteors.—Spectrum Photography.—Vogel's dyed plates.—Abney's infra-red Photographs.—Huggins's Stellar Photographs.—The Draper Memorial.—The province of Photography. 390-416

BOOK X.

CHRONOLOGICAL ASTRONOMY.

CHAPTER I.

TIME GENERALLY.

What Time is.—The Sidereal Day.—Its length.—Difference between the Sidereal Day and the Mean Solar Day.—The Equation of Time.—The anomalous Year.—Use of the Gnomon.—Length of the Solar Year according to different observers.—The Julian Calendar.—The Gregorian Calendar.—Old Style versus New Style.—Romish miracles.—Table of differences of the Styles. 417-429

CHAPTER II.

SUB-DIVISIONS OF TIME.

Hours.—Commencement of the Days.—Usage of different nations.—Days.—Weeks.—Origin of the English names for the days of the week.—The Egyptian 7-day period.—The Roman week.—Months.—Memoranda on the months.—Years.—The Egyptian year.—The Jewish year.—The Greek year.—The Roman year.—The Roman Calendar and the reforms it underwent.—The French revolutionary Calendar.—The year.—Its sub-divisions into quarters.—Quarter days. 430-443

CHAPTER III.

THE ALMANAC.

Means of measuring Time.—The Almanac.—Epitome of its contents.—Times of Sunrise and Sunset.—Positions of the Sun, Moon, and Planets.—The Phases of the Moon.—The Ecclesiastical Calendar.—The Festival of Easter.—Method of calculating it. 444-453

CHAPTER IV.

CYCLES.

The Dominical or Sunday Letter.—Method of finding it.—Its use.—The Lunar or Metonic Cycle.—The Golden Number.—The Epact.—The Solar Cycle.—The Indiction.—The Dionysian period.—The Julian period.—De Cheseaux's investigation of the Cycles mentioned in the Book of Daniel. ... 454-467

BOOK XI.

A SKETCH OF THE HISTORY OF ASTRONOMY ... 468-486

BOOK XII.

ASTRONOMICAL BIBLIOGRAPHY.

CHAPTER I.

LIST OF PUBLISHED STAR CATALOGUES AND CELESTIAL CHARTS	487-505
--	--------	---------

CHAPTER II.

LIST OF BOOKS RELATING TO, OR BEARING ON, ASTRONOMY	506-515
---	--------	---------

BOOK XIII.

ASTRONOMICAL TABLES	517-539
---------------------	--------	---------

VOCABULARY OF DEFINITIONS	541
---------------------------	--------	-----

INDEX	555
-------	--------	-----



LIST OF ILLUSTRATIONS.

Fig		Page
1.	The 30-inch Refractor of the Pulkova Observatory	Plate I. <i>Frontispiece</i>
2.	Observatory erected at East-Bourne, 1854	<i>Title-page</i>
3.	The Gregorian Telescope	2
4.	The Cassegrainian Telescope	2
5.	The Earl of Rosse's 3-ft. Reflector	Plate II. 3
6.	The Newtonian Telescope	5
7.	The Herschelian Telescope	5
8.	Sir W. Herschel's 40-ft. Reflector as mounted at Slough	6
9.	The Earl of Rosse's 6-ft. Reflector	Plate III. 7
10.	Bed for Mirrors adopted by Browning	10
11.	Browning's method of mounting the smaller mirror	10
12.	Browning's method of mounting the smaller mirror	10
13.	Diffraction Rings: object-glass perfectly adjusted	16
14.	Diffraction Rings: object-glass not perfectly adjusted	16
15.	The Galilean Telescope	18
16.	Opera-Glass	18
17.	The Positive Eye-piece	18
18.	The Negative Eye-piece	19
19.	The Terrestrial Eye-piece	22
20.	The Pancratic Terrestrial Eye-piece	22
21.	Grubb's Terrestrial Eye-piece	23
22.	Berthon's Dynamometer	24
23.	The Diagonal Eye-piece	25
24.	Dawes's Solar Eye-piece	26
25.	Hilger's Solar Eye-piece	27
26.	Cooke's Polarising Solar Eye-piece: with 2 Surfaces	28
27.	Cooke's Polarising Solar Eye-piece: with 3 Surfaces	28
28.	Airy's Prismatic Eye-piece	29
29.	Airy's Prismatic Eye-piece	29
30.	The Reticulated Micrometer	31
31.	The Parallel-Wire Micrometer	32
32.	Diagram illustrating the measurement of Angles of Position	35
33.	The Duplex Micrometer	36
34.	Bidder's Micrometer	38

Fig.		Page
35.	Burnham's Bright-wire Micrometer used at the Lick Observatory	40
36.	Barlow-Lens Double-Image Micrometer	43
37.	The Ring Micrometer	44
38.	Slipping-piece	45
39.	Telescope mounted on a Pillar-and-claw Stand	48
40.	Telescope mounted on a Pillar-and-claw Stand, with Finder and Vertical Rack Motion	49
41.	Telescope mounted on a Pillar-and-claw Stand, with Finder, Vertical and Horizontal Rack Motions, and Steadying Rods	51
42.	Telescope on Tripod Stand, with Vertical and Horizontal Rack Motions	52
43.	Telescope Stand with Motion in Altitude and Azimuth, devised by Proctor	53
44.	Altazimuth Mounting for Reflectors, devised by Brett	55
45.	Altazimuth Mounting for a small Reflector	56
46.	Adjustable Altazimuth or Equatorial Mounting for a medium-sized Reflector	57
47.	Altazimuth Mounting for a large Reflector	58
48.	Altazimuth Mounting for a large Reflector, by Browning	60
49.	Combined Altazimuth and Equatorial	Plate IV. 62
50.	Conversion of Pillar-and-claw Stand into Equatorial (Earl of Crawford's plan)	66
51.	The English Equatorial of the Bedford Observatory, 1829	68
52.	German Equatorial, by Horne and Thornthwaite	70
53.	The German Equatorial, as modified by Brodie	71
54.	Equatorial for different latitudes, by Bardou	72
55.	Equatorially-mounted Refractor, aperture $4\frac{1}{2}$ inches	Plate V. 73
56.	Twin Equatorial of French manufacture, by Bardou	Plate VI. 75
57.	Warner and Swasey's Driving Clock	77
58.	Portable Equatorial Mounting by Tulley	78
59.	Equatorial of French manufacture, by Secrétan	Plate VII. 79
60.	Equatorial of French manufacture, by Secrétan	Plate VIII. 81
61.	Equatorial of French manufacture, by Secrétan	Plate IX. 83
62.	The 6-inch Equatorial of the Northfield Grange Observatory, East-Bourne	Plate X. 85
63.	The 8-inch Equatorial of the Cork Observatory	Plate XI. faces 86
64.	The Equatorial of the Fernhill Observatory (Isle of Wight)	Plate XII. 87
65.	15-inch Equatorial at the Scarborough Observatory	Plate XIII. faces 88
66.	$9\frac{1}{2}$ -inch Equatorial by Warner and Swasey	Plate XIV. 89
67.	The great Refractor of the Lick Observatory, California	Plate XV. 91
68.	Window Equatorial Mounting, devised by Erek	93
69.	Portable Equatorial Mounting on Tripod	94
70.	The Star-Finder	96

Fig.		Page
71.	Twin Equatorial, by Grubb	Plate XVI. faces 96
72.	Equatorially-mounted Reflector	Plate XVII. 97
73.	Equatorially-mounted Reflector	Plate XVIII. 99
74.	Equatorially-mounted Reflector at the Royal Observ- atory, Edinburgh	Plate XIX. 101
75.	Universal Equatorial for a Reflector	104
76.	Equatorial Reflector at Dr. Konkoly's Observatory, by Grubb	105
77.	The great Reflector of the Melbourne Observatory	106
78.	The Equatorial "Coudé" at Paris	Plate XX. 108
79.	The Portable Transit Instrument	119
80.	The Portable Transit Instrument	120
81.	Transit Instrument, with reversing arrangement and setting Circles	121
82.	The Transit Instrument of the Bedford Observatory	122
83.	The Transit Instrument of the Fernhill Observatory, Isle of Wight	123
84.	The Side-Transit Instrument	124
85.	Transit Circle of French manufacture, by Secrétan	Plate XXI. 125
86.	Transit Circle of French manufacture, by Secrétan	Plate XXII. 127
87.	Arrangement of the Wires in a Transit Instrument	129
88.	Venus and a Star in the field of a Transit Instrument	135
89.	Cheap Transit Instrument devised by Mr. Latimer Clark	142
90.	Clark's Window Transit	144
91.	The Meridian Circle of the Paris Observatory	Plate XXIII. 145
92.	Short's Rating Instrument	147
93.	The "Lee" Circle made by Troughton in 1793	148
94.	The Sextant	150
95.	The Artificial Horizon	155
96.	The Portable Altazimuth, or Transit Theodolite	166
97.	Everest's Theodolite	167
98.	Zenith Telescope of the U. S. Survey	169
99.	The Horizontal Floating Collimator	171
100.	The Vertical Floating Collimator	172
101.	Theory of the Vertical Floating Collimator	173
102.	The Almucantar	174
103.	The Heliometer at the Radcliffe Observatory, Oxford	Plate XXIV. 176
104.	Airy's Orbit-Sweeper	178
105.	The Astro-photo-heliograph at the Paris Observatory	Plate XXV. 179
106.	The Astronomical Spectroscope	182
107.	Browning's Star Spectroscope	183
108.	The Automatic Spectroscope	185
109.	Young's Astronomical Spectroscope	187
110.	Pritchard's Wedge Photometer	188
111.	Knobel's Astrometer	191
112.	Ground-plan of the Bedford Observatory	197
113.	Elevation of the Bedford Observatory	197

Fig.		Page
114.	Ribs of a Dome intended to be covered with copper or sheet iron	199
115.	Section of bearings for a Dome (Bedford Observatory)	201
116.	The Observatory at Queen's College, Cork	203
117.	The Transit Instrument of the Bedford Observatory	205
118.	Setting Circle devised by Ramsden	206
119.	Meridian Mark	207
120.	Observatory Clock	210
121.	American Chronograph Plate XXVI.	214
122.	Dawes's Observing Chair	216
123.	Observatory Ladder	217
124.	The Dearborn Observatory Ladder	218
125.	Observatory Chair devised by Knobel	219
126.	Plans of Observatory for a 7-ft. Equatorial and a Transit Instrument Plate XXVII. [At end of volume.]	
	A. Ground-plan.	
	B. General Elevation.	
	C. Elevation of Dome and of Transit Shutter.	
	D. Plan of Top of Dome.	
	E. Section of Cills of Dome.	
	F. Elevation of end of top Shutter.	
	G. Section through Transit Shutter.	
	H. Section through Dome Shutter.	
127.	Northfield Grange, East-Bourne: example of Obser- vatory built as part of a private Dwelling-house	227
128.	Plan of a Romsey Observatory. Plate XXVIII. [At end of volume.]	
	A. Ground-plan.	
	B. South Elevation.	
	C. Section of Cill of Dome.	
	D. Shutter Fastener.	
	E. Plan of top of Dome.	
	F. Catch to fasten Dome.	
	G. East Elevation of Transit Room.	
129.	The Observatory at Austwick Hall, Lancashire: "Romsey" Type	229
130.	30-ft. Dome at the Greenwich Observatory Plate XXIX.	236
131.	N. E. View of the Lick Observatory, U. S.	238
132.	General view of the Washburn Observatory, Madison, Wisconsin, U. S. Plate XXX.	239
133.	Simple form of Driving Clock	252
134.	The Parallaxic Ladder: General View	253
135.	Details of the Frame: a Strut or Sheer	254
136.	Details of the Frame: front of the Frame	254
137.	Details of the Frame: section of the Frame	254
138.	Details of the Pivot	256
139.	Details of the Pivot	256
140.	Details of the Pivot	256
141.	Details of the South Foot	257

Fig.		Page
142	Browning's Observing Box : plan	258
143.	Browning's Observing Box ; elevation	258
144.	Steinheil's Transit Prism	259
145.	Sidereal Time Indicator	261
146.	Sketch Plan of the planet Saturn (N. E. Green)	272
147.	Plan for curing Triangular Star-discs	276
148.	The composition of Light	300
149.	The Solar Spectrum	301
150.	Telluric Group α (<i>Ångström</i>)	314
151	Sun-spot and part of its spectrum near the D lines	317
152.	Contortions of F line on disc of Sun	318
153.	Part of the Spectrum of a Sun-spot, Nov. 27 and 30, 1880	322
154.	Spectrum of the Sun near line C, with the slit radial	329
155.	Spectrum of the Sun with the slit tangential, showing line C reversed on the Chromosphere	329
156.	Slit placed radially to view a prominence	330
157.	Slit placed tangentially to view a prominence	330
158.	Changes in prominences noticed by Young	331
159.	Bending of the line $H\beta$ in the spectrum of a promin- ence	332
160.	Spectrum of Uranus, according to Vogel	341
161.	Spectrum of Olefiant Gas and Winnecke's Comet, 1868	343
162.	Secchi's Types of Stellar Spectra	355
163.	Spectrum of T Coronæ	365
164.	Spectrum of Mira Ceti	368
165.	Spectrum of the Nebula ζ^4 IV. Draconis	371
166.	Line F in spectrum of Sirius compared with Hydro- gen, Dec. 1875	373
167.	Region near F in spectra of the I st and II nd Types	375
168.	Chart showing distribution of Stars observed for motion in the line of sight	377
169.	Spectra of Sirius and of the great Nebula in Orion (<i>Huggins</i>)	386

BOOK VII.

PRACTICAL ASTRONOMY^a.

CHAPTER I.

THE TELESCOPE AND ITS ACCESSORIES.

Two kinds of telescopes.—Reflecting telescopes.—The Gregorian reflector.—The Cassegrainian reflector.—The Newtonian reflector.—The Herschelien reflector.—Lord Rosse's large reflector.—Nasmyth's reflector.—Browning's mountings for reflectors.—Adjustment of reflectors.—Refracting telescopes.—Refractors and reflectors compared.—Spherical aberration.—Chromatic aberration.—Tests for both.—Theory of Achromatic combinations.—Tests of a good object-glass.—The Dialyte.—The Galilean refractor.—Eye-pieces.—The positive eye-piece.—The negative eye-piece.—Formulæ for calculating the focal lengths of equivalent lenses.—Kellner's eye-piece.—The Barlow lens.—The Terrestrial eye-piece.—The Pancratic Terrestrial eye-piece.—Grubb's Prismatic Terrestrial eye-piece.—Ramsden's Dynamometer.—Berthon's Dynamometer.—Dawes's rotating eye-piece.—The diagonal eye-piece.—Dawes's solar eye-piece.—Hilger's solar eye-piece.—The Polarising solar eye-piece.—Airy's eye-piece for atmospheric dispersion.—Micrometers.—The reticulated micrometer.—The parallel-wire micrometer.—The position-micrometer.—Measurement of angles of position.—Grubb's Duplex micrometer.—Bright-wire micrometer.—Bidder's micrometer.—Burnham's micrometer.—The Double image micrometer.—The Ring micrometer.—The Square Bar micrometer.—The Zone Reticle.—Slipping-piece.—Telescope tubes.

IN the present Book I shall treat of the telescope^b, and of some of its various practical applications to astronomical purposes ; to which will be added other information calculated to be useful to amateur observers.

^a On everything connected with the subject of the present Book the reader may consult with advantage Pearson's *Practical Astronomy*; Loomis's *Practical Astronomy*; Challis's *Lectures on Prac-*

tical Astronomy and Instruments, and a very exhaustive modern American work, Chauvenet's *Spherical and Practical Astronomy*.

^b τῆλε at a distance, and σκοπέω I see.

Telescopes are of 2 kinds—reflecting (or catoptric), and refracting (or dioptric): in the former an image of the object to be viewed is produced by a concave reflector, in the latter by a converging lens.

There are four principal constructions of reflecting telescopes:—

1. The Gregorian, invented by James Gregory, of Aberdeen, in 1663.
2. The Newtonian, invented by Sir Isaac Newton in 1669.
3. The Cassegrainian, invented by Cassegrain in 1672.
4. The Herschelian, invented by Sir William Herschel in the latter part of the last century.

The *Gregorian Telescope* consists of a large concave metal speculum, in the centre of which a circular aperture is pierced.

Fig. 3.



THE GREGORIAN TELESCOPE.

A 2nd concave speculum, with its concave surface turned in the other direction, is placed in the axis of the tube at a distance from the larger speculum rather *greater than the sum* of their focal lengths. A smaller tube, carrying an eye-piece, is placed at that extremity of the larger tube where the speculum is.

The *Cassegrainian Telescope* is similar in all respects to the Gregorian, except that the smaller speculum is convex instead

Fig 4.

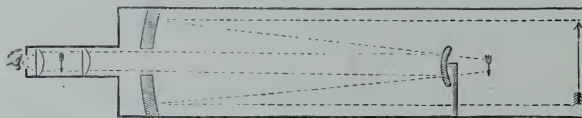

THE CASSEGRAINIAN TELESCOPE.

of concave, and that it is placed in the tube at a distance from the larger speculum *equal to the difference* of their focal lengths.

In the *Newtonian Telescope* a large concave reflector is placed at one end of the tube. At a distance from the larger mirror, *less than its focal length*, is placed, at an angle of 45° to the optic



THE EARL OF ROSSE'S 3-FT. REFLECTOR.

axis of the telescope, a plane reflector, by which the rays proceeding from the object are turned to the side of the larger tube,

Fig. 6.

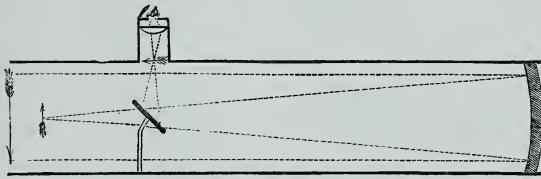

THE NEWTONIAN TELESCOPE.

where there is a smaller one in which an eye-piece for viewing them is placed. Instead of the plane reflector, Foucault used a prism.

In all these telescopes the central rays are lost, because in the Gregorian and Cassegrainian arrangements the central portion of the mirror is cut away, and in the Newtonian the central rays are intercepted by the plane mirror.

In the *Herschelian Telescope* the large speculum is not fixed in the tube with its diameter at right angles to the axis of the tube,

Fig. 7.



THE HERSCHELIAN TELESCOPE.

but is slightly inclined to it; by this means the image of the object observed is brought to the interior edge of the tube, where it is directly examined by the eye-piece, instead of through the medium of a 2nd reflector. The advantages of this plan are, that not only can observations be made with greater ease, but a saving of light is effected by dispensing with the 2nd reflector. It was with an instrument constructed in this way that Sir W. Herschel made his numerous and important observations and discoveries, of which many have already been brought under the notice of the reader^c.

^c Described at great length in *Phil. Trans.*, vol. lxxxv. p. 347. 1795.

Respecting Lord Rosse's larger instrument Smyth says:—"This remarkable and mighty 'optick tube' has a speculum 6^{ft} in diameter, with a reflecting surface of 4071 inches, and weighing upwards of 3 tons. Its focal length is 52^{ft}; but the tube—made of deal hooped with iron—is 56^{ft} long, including the speculum box, the whole weighing above 15 tons. It is fixed to a large universal joint, imbedded in solid masonry about 6^{ft} below the ground, which allows it to turn freely, and

Fig. 8.

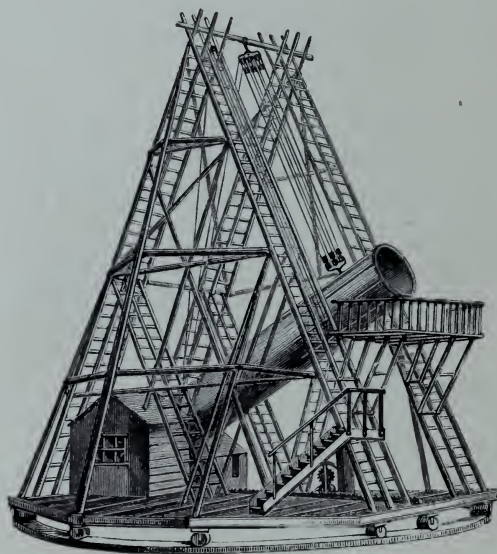

SIR W. HERSCHEL'S 40-FT. REFLECTOR AS MOUNTED AT SLOUGH.

is elevated or depressed by a chain and windlass, with counterpoises in every direction. On each side of this tube, which is 7^{ft} in diameter, in a line with the meridian, and at 12^{ft} distance, a stout wall is built—72^{ft} long by 48^{ft} high on the outer side, and 56^{ft} on the inner; allowing a lateral movement of the telescope of $\frac{1}{2}$ an hour on each side of the culminating line; that is, a term of one hour in the 24^{ft} interval from wall to wall. Every portion is an evidence of powerful mental and mechanical energy; but he who wishes to see γ Draconis pass the meridian, or other heavenly body in the zenith, must stand at an

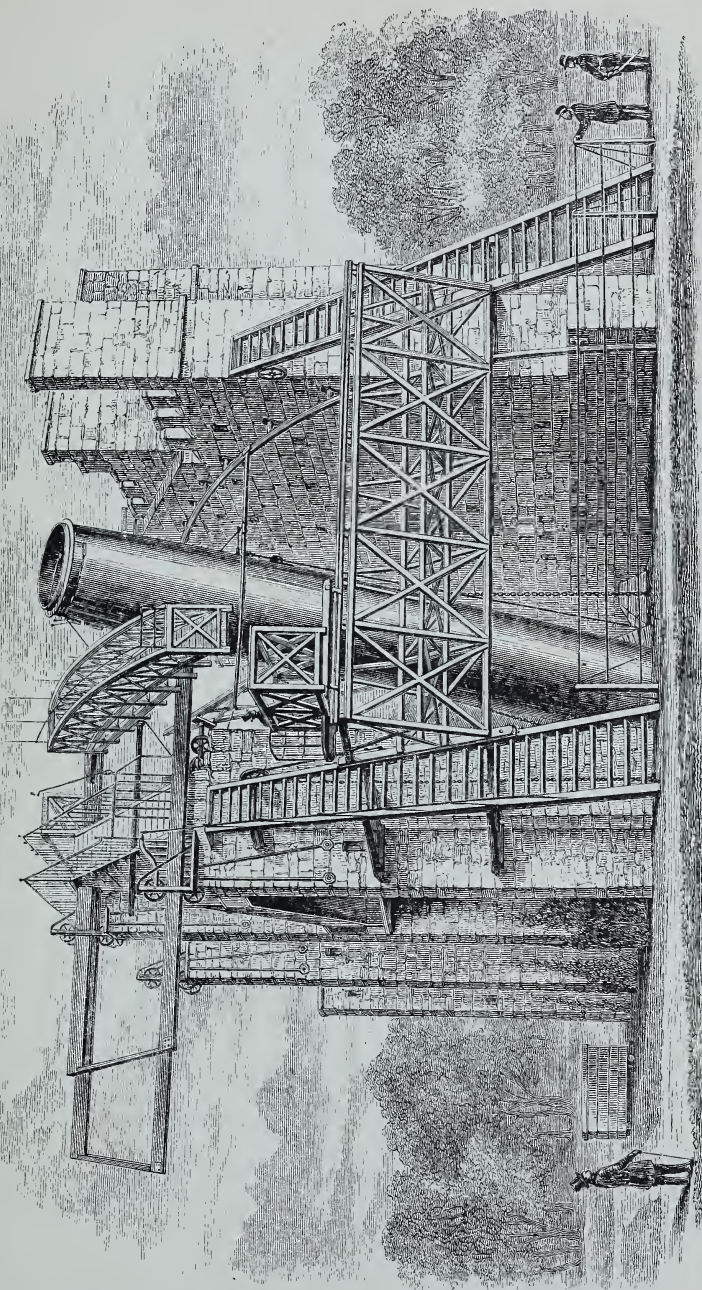

THE EARL OF ROSSE'S 6-ft. REFLECTOR.

elevation of at least 50^{ft} from the ground." The original cost of this instrument was about 12,000*l.*^d At the Paris Observatory there has recently been erected a 4-ft. Newtonian silvered-glass Reflector, of shorter focal length (24^{ft}) and mounted in a much more handy form than the Parsonstown Reflector.

A modification of Newton's arrangement has been made use of with satisfactory results by Mr. James Nasmyth, the eminent machinist. The rays reflected from the great speculum are received either upon a small speculum, or upon a prism, placed in the axis of the tube between the focus and the great speculum. By this they are reflected at right angles, and the image is formed in one of the trunnions (made tubular for the purpose) on which the instrument turns. The image is then viewed in the usual way. The advantage accruing from this arrangement is that the great tube can be moved through any extent of altitude, whilst the lateral or trunnion tube, in which is placed the eye-piece, remains in one position, and thus the observer can survey any vertical circles in the sky without continually changing his station. The inventor has a reflector of this construction erected at his residence at Penshurst, the tube of which is 28^{ft} long and 4^{ft} 6ⁱⁿ in diameter. The azimuthal movement is given by a turn-table similar to that used on railways for turning locomotive engines.

Reflecting telescopes were for many years but little used (always excepting a few large ones of historic note, so to speak), but their employment is now greatly on the increase; and the more modern sort, having mirrors made of silvered glass instead of speculum metal, now compete with refractors in regard to efficiency balanced against lesser cost. Attention has been a good deal drawn to them of late, and With of Hereford (working originally under the direction of a very skilful amateur, the Rev. H. C. Key, M.A.), Foucault of Paris, and Steinheil of Munich, have turned out instruments which have been very favourably reported upon by competent judges. Mr. With confines

^d For a full description of it see *Phil. Trans.*, vol. cxxx. p. 503. 1840.

his attention to the grinding of mirrors, and leaves the mounting to be done by others^o.

Fig. 10 is a representation of the bed employed by Browning for With's mirrors.

The bottom of the mirror A is ground to an approximately true surface, and the same thing is done with the bottom of the

Fig. 10.

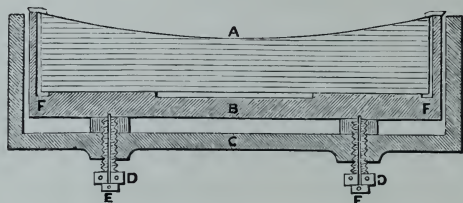

inner cell B, on which it rests. Parallelism is obtained by the use of the adjusting-screws D D and E E; and the mirror can be removed from the tube of the telescope and replaced with great facility without loss of adjustment. A tight-fitting brass cap closes the inner cell, and protects the silvered surface when not in use.

Fig. 11.

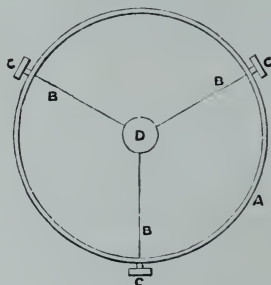
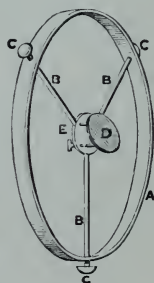

Fig. 12.



A reference back to Figs. 3, 4 and 6 will show the small mirror in each case mounted on a single stout arm, and this has always (I believe) been the method adopted; but Browning employs 3 thin strips of chronometer-spring presented edgewise to the axis of the telescope, as in Figs. 11-12. This plan of mounting the

^o For a succinct account of the process of grinding mirrors see Lockyer's *Stargazing*, p. 127.

smaller mirror has the important advantage that the 3 slender springs offer much less obstruction to the passage of the optic rays than does the one thick arm commonly used, and give facilities for accurately centering the smaller mirror.

It may not be out of place to offer a few observations on the adjustment of Newtonian reflectors. But what I shall say must be understood as applying more particularly to silvered glass reflectors, which may be said to have in great measure superseded all others.

If the mirror has been taken out of its cell, carefully remove any dust which may have accumulated on the under side or in the cell; then screw on the ring which confines the mirror. Should the mirror be found to have any lateral motion in its cell, before screwing on the ring insert a few long slips of stout white paper between the edge of the mirror and the cell, leaving it however an easy fit. Having secured the mirror in the tube by means of the 3 milled-headed screws, the cover being on the mirror during this operation, insert into the eye-tube an eye-piece from which the lenses have been removed. Looking now through the eye-tube, shift the diagonal mirror by the screws provided for the purpose until the reflected image of the cover is seen in the centre of the diagonal mirror. To do this, loosen the milled-headed screw behind the mounting of the diagonal mirror; turn the mirror until the image of the cover appears central in one direction, and re-clamp the diagonal mirror by means of the screw. At the back of the plate, on which the diagonal mirror turns, there is another screw. By means of this the reflected image of the cover may be made central in the other direction. On clamping this screw this adjustment should be complete. To adjust the mirror take the cover off and replace the mirror in the tube. Then move the screws at the bottom of the outside cell which contains the mirror, until, on looking through the eye-tube, the image of the diagonal mirror is seen in the centre of the reflection of the large mirror. The large hollow screws move the large mirror, and the smaller screws which run through the larger ones clamp the mirror. This clamping having been

performed the adjustment should be complete, and the telescope may be directed to an object and focussed as in the case of a refractor.

The diagonal mirror itself will probably now require a little adjustment. Direct the telescope to a bright star, or, in the daytime, to some bright point of light, using an eye-piece of high power, say 50 to each inch of aperture. Observe if the image is deformed by a flare in one direction. If not, the diagonal mirror is properly adjusted. But if a flare should appear on either side of the image, that part of the diagonal mirror towards which the flare projects must be gently moved *from* the observer.

To adjust the finder, cause some well-defined and distant terrestrial object to appear in the centre of the field of the large telescope, using for the purpose a rather high power. Then looking through the finder, bisect the object with the cross-wires by turning, as may be necessary, the adjusting-screws attached to the rings which hold the finder. Repeat this adjustment several times if needs be, and finally, by the aid of a bright star in substitution for a terrestrial object.

I shall not enter at any greater length into the consideration of reflecting telescopes, for though they have come a good deal into use again of late years, yet the more durable character and greater manageability of refractors, combined with the lessening in their cost brought about by modern improvements in manufacturing processes, have made them much more sought after than was the case half a century ago^f.

The question naturally suggests itself; How do refractors and reflectors compare with one another as regards their light-grasping powers, inch for inch of aperture? For smaller apertures it is considered that for a reflector to do the work of a refractor it must have an aperture that is double; *e.g.* that a reflector must have an aperture of 8ⁱⁿ to do the work capable of being done by a 4-in. refractor. It is thought

^f For particulars respecting the manufacture of reflecting telescopes, see papers by the late Earl of Rosse (Oxmantown); in *Phil. Trans.*, vol. cxxx. p. 503, 1840; vol.

cli. p. 681, 1861; by Robinson, in *Phil. Trans.*, vol. clix. p. 127, 1869; by Lassell in *Mem. R.A.S.*, vol. xviii. p. 1; H.C. Key, *Month. Not.*, vol. xxiii. p. 199, April 1863.

however by competent authorities that this ratio must be reduced as the aperture increases and that a 20-in. refractor is equalled by a 30-in. reflector, and that a 50-in. refractor, could such be made, would be actually inferior to a 50-in. reflector. These are the conclusions mainly of Dr. Robinson^s, but the matter is one which has not been exhaustively investigated. And it depends moreover on uncertainties on both sides; on the different translucency of different object-glasses and on the different reflecting powers of different reflecting surfaces.

A refracting telescope in its simplest form consists merely of a double convex lens which forms an image of the object to be viewed (and hence termed the *object-glass*), and a second and smaller double convex lens (called the *eye-piece*), used as a simple microscope to examine the image formed by the first. For astronomical purposes the object-glass is double (sometimes triple) for the purpose of neutralising certain optical inconveniences, called *spherical* and *chromatic aberration*, and the eye-glass is generally composed of 2 lenses suitably combined, which together form the *eye-piece*.

It will be readily understood that it is no part of my present object to furnish an elaborate account of the theory of instrumental optics; the remarks which follow must therefore be understood to have reference merely to a few general propositions, with which every amateur astronomer ought to be acquainted. The initial conditions of a good refractor have reference to 2 points: (1) the quality of the material glass and the excellence of its polish should be such that the maximum of light should be transmitted through it; (2) its curves should be such that the effects of the aberrations spoken of should be reduced to a minimum.

Spherical aberration arises from the circumstance that there are no curvatures practically attainable for a lens such that *all* the rays of light coming from a distant point can be *exactly* united in a common focus.

Chromatic aberration depends on the unequal refrangibility of the different coloured rays which together make white light—so

^s *Month. Not.*, vol. xxxvi. p. 305, May 1876.

that when an observer views an object through a lens he will not see the image perfectly defined and colourless, but more or less fringed with colour.

In order to lessen as far as possible this latter annoyance, the telescope-makers of by-gone days constructed lenses of great focal length (some of them had foci as long as 300^{ft}); by this means the chromatic dispersion was diminished in comparison with the size of the image formed. Dollond, from an examination of the different kinds of glass then in use, found that some specimens, under a given mean refraction, dispersed colours much more than others; and starting with this as a basis, he elaborated the compound and achromatic object-glass now in use. This invention was made in 1758, and may well be looked upon by Englishmen as a great national triumph; for it is not too much to say that by its means optical science has been revolutionised. An achromatic object-glass is formed of a convex lens of crown-glass (which used to be of a greenish hue) and a concave lens of flint-glass (which has usually a yellowish-white hue), placed in contact, the former outermost. By a proper arrangement of their focal lengths (a subject of considerable theoretical and mechanical difficulty) any 2 selected parts of the spectra formed by these lenses can be united, and the chromatic dispersion is thus to a great extent got rid of, without destroying the refractive power of the object-glass. When a ray of light falls upon such a combination it is acted upon by each component: the crown-glass renders it convergent and disperses it; the concave lens reducing the convergence neutralises the dispersion, and a colourless image is (or should be) formed at the focus.

To test whether the spherical aberration has been duly corrected proceed as follows:—point the telescope towards a moderately bright star, say one of Mag. 3, and focus the instrument carefully. Then cover the object-glass with a circular piece of cardboard, in the centre of which a circular hole has been cut having a diameter of about half that of the entire cardboard circle. If the telescope is found to be still in focus, the spherical aberration has been duly corrected; but if otherwise the necessary

correction has not been duly made. Should the eye-piece require to be *pushed in*, the instrument has been "*over-corrected*:" should it require to be *drawn out*, it has been "*under-corrected*." As a supplementary test, the cardboard cover may be shaped to obstruct the central rays and leave a free passage for the outer rays.

To test whether the chromatic aberration has been duly corrected proceed as follows:—point the telescope towards some bright object, such as the Moon or Jupiter, and focus the instrument carefully. If on *pushing in* the eye-piece a *purple* ring appears round the object examined, whilst on drawing it *out* a *green* ring becomes visible, the chromatic aberration has been duly dealt with; for the colours in question are the central ones of the secondary spectrum appearing as and when they should do. Challis points out that "It is not possible with 2 lenses completely to correct colour; but it is of importance to remark that the residual colour is least injurious when it has a purplish tint, being composed of rays lying towards the violet end of the spectrum, because the light of these is much less intense than that of those towards the red end^h."

Be it understood that should a given telescope fail to stand these tests, or either of them, none but an optician can apply a satisfactory remedy.

Before purchasing a mounted object-glass it would be well to submit it to various tests. Air bubbles, striæ, sandholes, scratches, and so forth, are of course, *primâ facie*, bad, but as they are not wholly incompatible with satisfactory performances, over-much attention need not be paid to them. The Rev. T. W. Webb wrote as follows:—"The image should be neat and well-defined with the highest power, and should come in and out of focus sharply: that is, become indistinct by a very slight motion on either side of it. A proper test-object must be chosen: the Moon is too easy; Venus too severe, except for first-rate glasses; large stars have too much glare; Jupiter or Saturn are far better; a close double star is best of all for an experienced

^h *Lectures on Pract. Ast.*, p. 7.

eye; but for general purposes a moderate-sized star will suffice. Its image in focus, with the highest power, should be a very small disc, almost a point, accurately round; without 'wings,' or rays, or mistiness, or false images, or appendages, except 1 or 2 narrow rings of light, regularly circular and concentric with the image; and in an uniformly dark field a slight displacement of the focus either way should enlarge the disc into a luminous circle. If this circle be irregular in outline, or much

Fig. 13.



Object-glass properly adjusted.

Fig. 14.



Object-glass not properly adjusted.

DIFFRACTION RINGS ROUND A STAR.

better defined on one side of the focus than the other, the telescope may be serviceable but is not of high excellence. The chances are many, however, against any given night being fine enough for such a purpose, and a fair judgment may be made by day from the figures on a watch-face, or a minute white circle on a black ground, placed as far off as is convenient. An achromatic, notwithstanding the derivation of its name, will show colour under high powers where there is a great contrast of light and darkness. This 'outstanding' or uncorrected colour results from the want of a perfect balance between the optical properties of the 2 kinds of glass of which the object-glass is constructed: it cannot be remedied, but it ought not to be obtrusive. In the best instruments it forms a fringe of violet, purple, or blue, round luminous objects in focus under high powers, especially Venus in a dark sky. A red or yellow border would be bad; but before condemning an instrument

from such a cause several eye-pieces should be tried, as the fault might lie there, and be easily and cheaply remedied¹.”

The “wings” spoken of in the above extract arise from the glass not being in every place of uniform refractive power—a defect sometimes partially remediable, but never altogether curable. For obvious reasons smaller telescopes are less liable to have their efficiency impaired by this cause than larger ones; and when, in using these latter, great precision of definition is particularly desired for any purpose, the defective portion may be covered over by a cardboard screen, and increased sharpness of outline secured at the expense merely of light—an alternative not always beneath notice.

Dawes used to say that the severest test of figure for an achromatic object-glass was the similarity of the image of a bright star viewed with the focus too long to the same image viewed when the focus is to an equal linear extent too short; the amount of the dissimilarity being a measure of the imperfection of the instrument. To this it may be added that in the case of a good telescope the movement of the eye-piece, to the extent of even $\frac{1}{10}$ in or out, should seriously derange the sharpness of the image. If it makes but little change the object-glass is not what it ought to be.

There is a form of achromatic telescope sometimes met with on the Continent called the “Dialyte.” In this the coloured dispersion produced by a single object-glass is corrected by a smaller concave lens, or combination of lenses, of high dispersive power, placed at a distance from the object-glass in the narrower part of the converging cone of rays and usually about midway between the object-glass and its focus.

To measure the diameter of the field of view of an opera-glass or small telescope—direct it on an object some 30^{ft} or 40^{ft} distant, such as a brick wall with bricks in visible courses. Take note of the space covered by the diameter of the field and measure this with

¹ *Celest. Objects*, p. 3. Readers disposed to try their hands at the construction of object-glasses for themselves, will

find some useful information in a paper by Webb in the *Engl. Mech.*, vol. xiii. p. 169. May 12, 1871.

a foot-rule. Divide $\frac{1}{2}$ this diameter by the distance of the object from the eye and the quotient will be the natural tangent of *half* the field of view. By means of a table of natural tangents the angular value sought may then be ascertained.

If the reader becomes possessed of a refracting telescope, he is strongly recommended never to attempt to take the object-glass to pieces. If the lenses require any adjustment, the maker, or at any rate a practical optician, is in every case the best person to take them in hand: unskilful treatment of them may cause much annoyance. It is different with eye-pieces, in consequence of their being less liable to derangement.

Fig. 15.



THE GALILEAN TELESCOPE.

The Galilean refracting telescope, so called from its inventor, the illustrious Florentine, consists of a double *convex* object-glass, the eye-glass being a double *concave* lens placed *in front* of the image formed by the object-glass. The common opera-glass is a telescope on this principle.

Fig. 16.

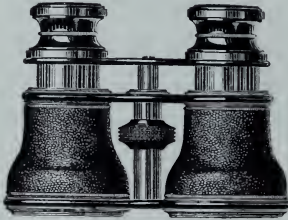

OPERA-GLASS.

Fig. 17.

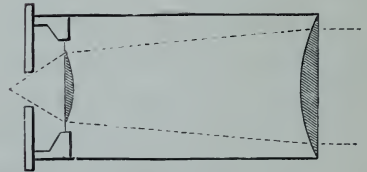

THE POSITIVE EYE-PIECE.

The eye-pieces commonly in use are the "positive," or Ramsden's, and the "negative," or Huygenian, so called from their having been first used by Ramsden and Huygens respectively.

A positive eye-piece consists of 2 plano-convex lenses placed

with the convex sides towards each other, of which the innermost is called the *field-glass*, and the outermost the *eye-glass*. The focal lengths are equal to each other ; and the field-glass should be so far within the focus of the eye-glass, that particles of dust upon the former cannot be seen when looking through the latter.

To find the single lens equivalent to an eye-piece of this description,

Divide the product of the focal lengths of the component lenses by their sum, minus the distance between them^k.

Thus, if the focal length of each lens be 1.5ⁱⁿ, and the distance between them 1ⁱⁿ, the length of the equivalent single lens will be—

$$\frac{1.5 \times 1.5}{3 - 1} = \frac{2.25}{2} = 1.125 \text{ inch.}$$

The positive eye-piece having its focus beyond the field-glass, is suited for use with micrometers, and other instruments having wires in the focus of the object-glass—a case to which the negative eye-piece, in consequence of its having, as we shall see, the focus between the glasses, is not suited.

A negative eye-piece consists also of 2 plano-convex lenses, the convex sides of both being in this case turned towards the object-glass. The ratio of the focal lengths of the lenses is usually 3 to 1, the latter representing the eye-glass. In order that the combination may be achromatic, it is indispensable that the distance between the lenses be equal to half the sum of their focal lengths.

In Fig. 18, *a* being the field-glass, a stop, *c c*, to limit the field of view is placed in the focus of the eye-glass *b*, and the eye-hole *d* is of such magnitude and distance from the eye-glass that the emergent pencils just find a passage through it. The passage of rays proceeding from an achromatic object-glass is shown in the

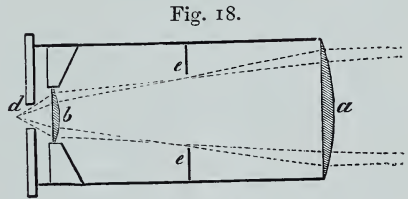

Fig. 18.

THE NEGATIVE EYE-PIECE.

^k A simple method of finding the focal lengths of small convex lenses is given by the Rev. T. W. Webb, in *Month. Not.* vol. xvii. p. 269. Oct. 1857.

figure, where it will be seen that after refraction by the field-glass they come to a focus at c , at which place the image of the object is formed. The rays again diverge, and by passing through the eye-glass b are in turn converged towards the point d , where they enter the eye, and form an inverted image on the retina.

To find the single lens equivalent to an eye-piece of this description,

Divide twice the product of the focal lengths of the component lenses by their sum.

Thus, if the focal length of the field-lens be 3, and of the eye-lens be 1, the length of the equivalent lens will be—

$$\frac{3 \times 1 \times 2}{4} = \frac{6}{4} = 1\frac{1}{2}.$$

Negative eye-pieces are almost universally used for all astronomical purposes, except in those cases where they are inadmissible, and which have already been alluded to when speaking of the positive eye-piece.

The following points should be borne in mind—

1. *That in an astronomical refracting telescope the distance between the object-glass and the eye-piece is the sum of their focal lengths, and the magnifying power is the ratio of their focal lengths.*

Thus, let the focal length of the object-glass of a telescope be 10^{ft} and of its eye-glass $\frac{1}{4}$ ⁱⁿ. Find the magnifying power.

Here 10 ft. = 120 inches.

Then as $\frac{1}{4} : 120 :: 1 : x$.

: 480.

2. *That in a Galilean telescope, the distance between the glasses is the difference of their focal lengths, and the magnifying power is the ratio of their focal lengths.*

Thus, let the focal length of the object-glass of a telescope be 6ⁱⁿ, and of its eye-glass $\frac{3}{4}$ ⁱⁿ. Find the magnifying power.

As $\frac{3}{4} : 6 :: 1 : x$.

: 8.

An eye-piece, called Kellner's from the name of its inventor, Kellner, an optician who lived many years ago at Wetzlar near

Frankfurt, is much approved of by some observers, as offering a larger field than a Huygenian of equivalent power, and with equally good definition. It consists of 2 lenses, the innermost, or field-glass, being a double convex crossed one—that is, having surfaces of different radii, the most convex towards the object-glass; and the outermost, or eye-lens, a meniscus of great convexity and small concavity.

Some observers are warm admirers of an invention known as the “Barlow lens,” which it must be admitted will often be found a useful accessory to a telescope. The Barlow lens¹ is a miniature object-glass in which the crown glass is concave and the flint glass convex or plano-convex with the curves so arranged as to result in the combination having a negative focus: it is in fact a *compound concave* lens. Such a lens introduced into the main tube of a telescope 5 or 6ⁱⁿ behind the eye-piece will intercept the rays transmitted by the object-glass before they come to a focus. The image is thrown further from the object-glass than it otherwise would be, and it is proportionally enlarged. By varying the situation of the Barlow the amount of the enlargement is varied. The Barlow adds from 50 to 100 per cent. to the effective magnifying power of the eye-pieces used with it, and so any eye-piece can be made to do the work of 2, but it does not improve the definition^m.

All the eye-pieces just described are especially intended for astronomical purposes, that is to say, by reason of the fact that they invert (or turn upside down) the images which they give, they are not convenient for the observation of terrestrial objects. As the smaller sizes of astronomical telescopes, say up to 4 inches of aperture, are often used for terrestrial purposes, they are frequently provided with a special eye-piece called an “Erecting” or “Terrestrial” eye-piece. This comprises 4 lenses instead of 2; whilst the first pair invert the image, the second

¹ It received its name from the late Prof. Barlow of Woolwich who investigated mathematically its principles, but Dawes appears to have been the first to

use it as far back as 1833. See Smyth, *Cycle*, vol. i. p. 343.

^m *Phil. Trans.*, vol. cxxiv. p. 205, 1834; *Month. Not.*, vol. x. p. 175, May 1850.

pair invert it back again and so it reaches the eye erect. In Fig. 19, *a* represents the field-glass, *b* the inner lens which completes the first stage of the magnifying process ; then *c* and

Fig. 19.

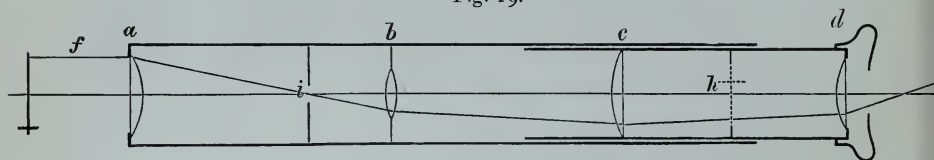

THE TERRESTRIAL EYE-PIECE.

d are the lenses of an ordinary negative eye-piece which undo the reversion caused by the first pair ; at *h* and *i* are stops which cut off extraneous light which would interfere with the distinctness of the final image. The course of the ray proceeding from *f* to the eye at *g* will indicate how the inverted image formed at *f* by the object-glass (not shown) eventually becomes erect at *h*, in the focus of the eye-glass.

Fig. 20.



THE PANCRATIC TERRESTRIAL EYE-PIECE.

The terrestrial eye-piece is sometimes so constructedⁿ as to permit of the distance between the lenses *b* and *c* being varied at pleasure ; in this way a variation in the magnifying power of the combination taken as a whole can be had, and a single eye-piece does the work of several, an advantageous economy for terrestrial purposes. The sliding tube is graduated, say from 40 to 100, which means that according as the tube is drawn out so the magnifying power will vary from 40, 50, &c. up to 100. This "Pancratic eye-piece," as it is called, is represented in Fig. 20. As drawn out in the engraving the power indicated is 63.

In Grubb's terrestrial eye-piece a prism is used which gives a much larger field than the ordinary form.

ⁿ This was Dr. Kitchiner's idea put in practice by the younger Dollond.

In practice it is not easy to determine with nicety the focal lengths of small lenses, and another method of ascertaining the magnifying power of a telescope may be given.

Accurately focus the telescope on a distant object, and turn the instrument towards the sky; withdraw the eye backwards a little way and a small luminous circle will be seen upon the eye-glass: this circle is nothing more than

the image of the object-glass. Measure by the aid of a fine scale of equal parts the diameter of the object-glass and the diameter of the luminous circle: the ratio will be the magnifying power of the eye-piece used. For example, suppose the diameter of the object-glass to be 3ⁱⁿ and the diameter of the circle of light 0.15ⁱⁿ. Then—

$$\frac{3}{0.15} = 20;$$

so that the telescope charged with the particular eye-piece used magnifies 20 times. The accuracy of the resulting evaluation will depend on the precision with which the spot in the eye-piece has been measured, and a micrometrical contrivance, called, from its inventor, Ramsden's *Dynamometer*, is in general use for this purpose^o.

✓ The Rev. E. L. Berthon's *Dynamometer*, made by Horne and Thornthwaite, is a simple but effective little instrument by the aid of which the magnifying power of any eye-piece can be accurately ascertained. It can also be used to measure the diameter of wire, the thickness of metal, or indeed of any round or flat object, whose diameter or thickness does not exceed $\frac{2}{10}$ in; and its accuracy is such that its indications are correct to $\frac{1}{1000}$ in. ✓

^o This is fully described in Challis's *Lectures on Pract. Ast.*, p. 391. For a scientific method of determining the magnifying power of a telescope with

great precision see a paper by Schäberle in *Month. Not.*, vol. xliii. p. 297. March 1883.

Fig. 21.

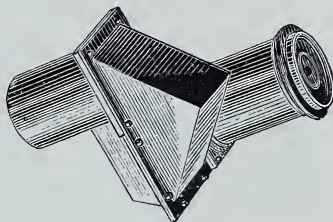

GRUBB'S TERRESTRIAL EYE-PIECE.

Having placed the eye about 10^{in} directly behind the eye-piece, so that the small circle previously alluded to is seen immediately in front of the eye-lens, the process of measuring

Fig. 22.

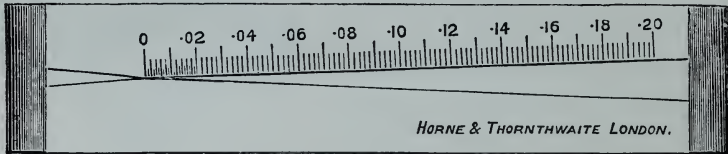

BERTHON'S DYNAMOMETER.

the image is performed as follows:—Holding the Dynamometer near the eye-piece, observe the miniature disc, by the aid of an ordinary pocket lens, of low power; shifting the Dynamometer until the two internal edges exactly touch the circumference of the image, note the division opposite the point of contact; this is the diameter of the image in decimals of an inch. Dividing now the diameter of the clear aperture of the object-glass by this decimal, the quotient is the exact magnifying power of the eye-piece when used with that particular object-glass. Example:—The clear aperture of the object-glass being 6.24^{in} , and the diameter of the image, as indicated by the Dynamometer, being $.026$, we obtain, by dividing 6.24 by $.026$, a quotient of 240 , which is consequently the magnifying power.

The diameter of wire, sheet metal, or other object, may be ascertained by sliding it along until the two edges just touch the internal sides of the Dynamometer, when the division exactly opposite the point of contact is equal to the diameter of the article measured. Thus, if a wire passes freely up the wide end of the triangular opening until it is stopped at the first short division beyond $.04$, its diameter is $.042^{\text{in}}$. The scale is so divided that each long division represents $.01^{\text{in}}$. Each of the first two long divisions from 0 is divided into 10 parts, each of which is equal to $.001^{\text{in}}$. Each of the remaining long divisions is divided into 5 parts, each equal to $.002^{\text{in}}$.

In using Berthon's Dynamometer reliance should not be placed

on a single result. In every case several distinct observations should be made and the mean taken as the definitive value.

To find approximately the magnifying power of an opera-glass—lay off on a board or other smooth surface of wood or cardboard several very distinct lines parallel to each other, say at a distance of 6ⁱⁿ apart. Set up the board at a distance of 30^{ft} perpendicular to the line of sight, and view the spaces, using the glass with one eye and the other eye without it. Note how many divisions, as seen with the unaided eye, equal one division shown by the glass. The number of the spaces seen with the unaided eye equivalent to the one space seen through the glass is the magnifying power of the instrument.

Dawes contrived an eye-piece for diminishing the apertures of telescopes without disturbing them, which is equivalent to the application of a diaphragm of the required dimensions to the object-glass. It consists of an eye-piece, furnished with a revolving diaphragm, containing apertures of different sizes, each of which can be brought into the centre of the field of view. By sliding one of these apertures towards or away from the object-

glass, the cone of rays is respectively reduced or augmented, which has the same effect as diminishing or increasing the aperture of the object-glass. A scale affixed shows the amount of the diminution of the aperture.

It is frequently inconvenient to observe objects near the zenith, and, with some forms of equatorial, the Pole-star and objects very near the Pole; to meet this difficulty a diagonal eye-piece is employed. This consists essentially of a tube sliding into the tube of the telescope at the eye-piece end, with another tube let into it at an angle of 90° to the axis. Opposite the secondary

Fig. 23.

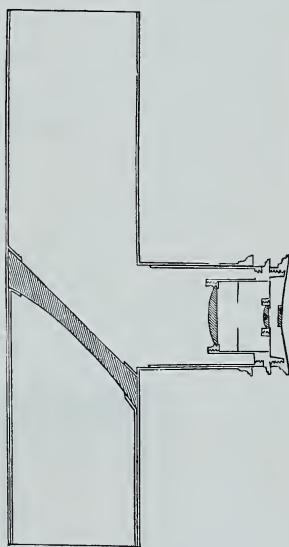

THE DIAGONAL EYE-PIECE.

tube is a plane reflector which may be either a piece of polished speculum-metal, or a glass (or rock-crystal) prism. The prism is to be preferred, as much less light is lost in the transmission of the incident rays.

An eye-piece arranged with a single-surface reflection prism is specially serviceable for observing the Sun. It is preferable to view this luminary by reflection and with such a form of prism, for several reasons: amongst others, the loss of light (about $\frac{1}{30}$ only is reflected) is an advantage, and by using a prism there is no second surface to yield a double reflection; and the rays of heat, which are always very inconvenient, almost entirely pass away into the air without traversing the magnifier, and endangering the glasses and the observer's eye^P. With apertures greater than 2ⁱⁿ, direct vision of the Sun becomes very hazardous.

Fig. 24.

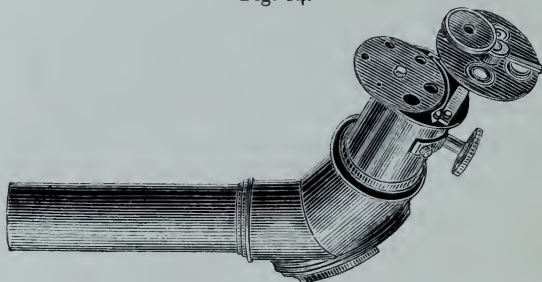

DAWES'S SOLAR EYE-PIECE.

A special eye-piece for the Sun was devised by Dawes^q, and works well, but is rather expensive. It consists of a circular metallic plate, faced on the inner side with ivory, and containing a series of apertures of various sizes from $\frac{1}{130}$ to $\frac{1}{2}$ ⁱⁿ; this plate is mounted on an axis in such a way that the holes may be brought in succession into the focus of the object-glass. The apertures serve to limit the field to very small dimensions *ad libitum*, and the field so curtailed is examined by single lenses

^P A form of construction proposed by Erck seems to offer some advantages over the diagonal solar eye-piece as ordinarily made. (See *Month. Not.*, vol.

xxxvii. p. 128. Jan. 1877.)

^q *Month. Not.*, vol. xii. p. 167. April 1852; *Mem. R. A. S.*, vol. xxi. p. 157. 1852.

mounted on another plate revolving concentrically with the former one. Superposed upon the wheel of single lenses is another wheel, containing a series of dark glasses of various shades, to suit the eye and magnifying power used. The single lenses are focussed on the apertures in the diaphragm by a rack and pinion movement, and this renders the eye-piece as a whole complicated and expensive, though it is admirably adapted for solar observation. The wheel of dark glasses is made to slip off the eye-piece, so that if required it can be devoted to other uses. Grubb by combining with this a polarising apparatus obviates the use of dark glasses.

Fig. 25.

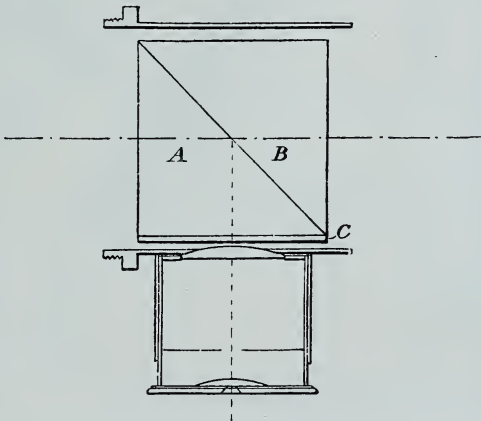

HILGER'S SOLAR EYE-PIECE.

Hilger has employed Canada balsam in prismatic eye-pieces made by him, and claims to have accomplished very successful results in the way of reduction of light and heat without any noticeable interference with definition under high powers. A is a prism of glass, B a prism of balsam. It is found that the amount of light reflected is so small that large apertures may be used without any further protection to the eye, but if a further diminution of the light is desired, it may be obtained by the use of a thin plate of neutral glass C cemented to the surface of the glass prism ^r.

^r *Month. Not.*, vol. xlv. p. 59. Nov. 1884.

A more simple form of solar eye-piece is that which consists of an adapter in which a diaphragm plate is fitted as above. The wheel of lenses is replaced by a tube, into which fit the diminutive positive eye-pieces required for use with a micrometer. Across the top of each eye-piece is a groove with cheeks, to retain in position a wedge of dark glass, capable of a sliding motion in

Fig. 26.

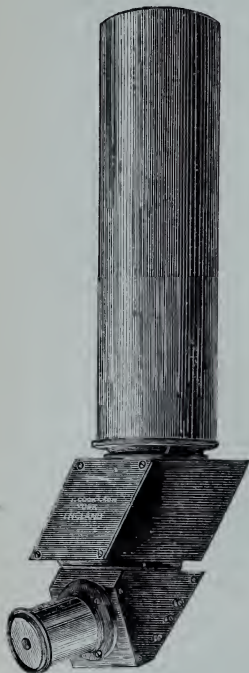

With 2 reflecting surfaces.

Fig. 27.

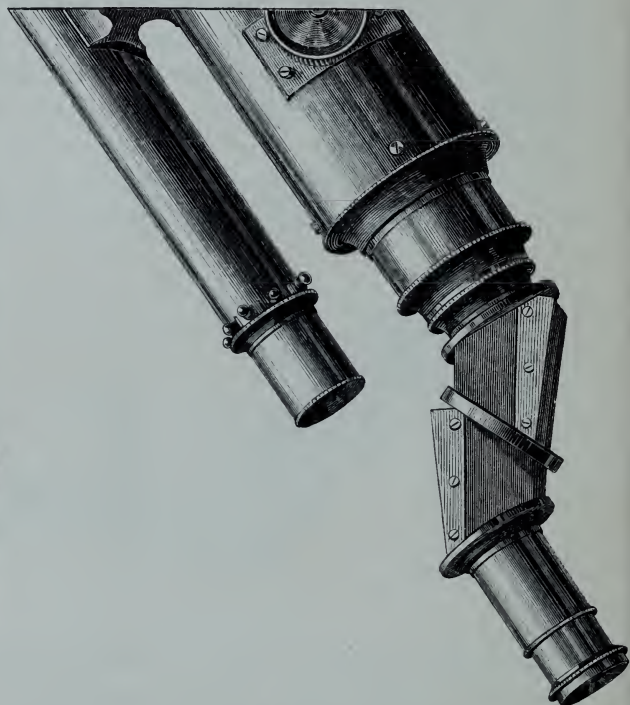

With 3 reflecting surfaces.

THE POLARISING SOLAR EYE-PIECE.

front of the eye lens, for varying the intensity of the shade. The largest hole in the diaphragm-plate should be equal to the field of the lowest power, so that the whole apparatus may, if desired, be advantageously used for other than solar purposes. It is a great feature in this construction that the rack and pinion adjustment for focussing is dispensed with. This is possible because all the positive eye-pieces have the same focus.

The principle of the Polarising Solar eye-piece depends upon a curious property of light discovered by Malus in 1808, viz., the polarisation of light at plane surfaces of transparent bodies. The eye-piece consists of two reflecting surfaces receiving the solar rays successively; the surface nearer the eye has a rotatory motion, but always keeps the same reflecting angle with the other surface. By turning the former surface a quarter round, it appears to lose almost entirely its power of reflection, the rays

Figs. 28, 29.

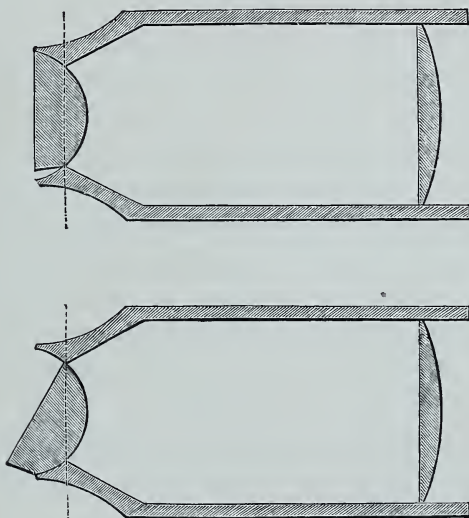

AIRY'S PRISMATIC EYE-PIECE.

of light being said to be "polarised by reflection;" the Sun's light can thus be diminished without any distortion of the object, and the natural tints need not be interfered with by coloured glasses. Often a third or fourth reflector is introduced, and by a single rotation of the one nearest the eye the light is diminished to a very small fraction at will; thus the Sun may be viewed for hours together without risk or pain to the eyes.

To meet the inconvenient effects of atmospheric dispersion on the images of celestial objects viewed at small elevations Sir G. B. Airy has contrived a special eye-piece which deserves mention here. It consists essentially of a common Huygenian eye-piece

of which the eye-glass (supposed to be plano-convex) is made broader than is strictly necessary for telescopic vision, causing it to press by its convex surface into a concave cup at the eye-end of the eye-piece, and allowing it to roll in that concavity, thus presenting different parts of its convex surface, though always in the same form and position, to the rays of light which come from the field-glass, but presenting to the eye a plane surface which in one position of the lens is normal to the axis of the telescope and in another position is inclined thereto. Fig. 28 shows the position of the lens in ordinary use; Fig. 29 shows its position when it is required to neutralise atmospheric dispersion (or chromatic separation produced by defective centering of the lenses of an object-glass). It will be seen that in each case the dotted line separates a plano-convex lens of definite form; but that in the first case there is, as it were, applied to it on the eye-side, a piece of glass bounded by two parallel surfaces; and in a second case there is applied to it a prism whose angle is varied as the position of the lens in its cup is varied. The eye-piece is provided with a rotatory motion round the axis of the telescope. Such an eye-piece as this presents the following incidental advantages:—it introduces no additional glass; it allows the use of a prism the angle of which can within certain limits be varied at pleasure; and the correction for spherical aberration is not disturbed^s.

Further remarks on eye-pieces will be made in a subsequent chapter devoted to practical hints on observing. It may suffice to add here that a telescope once focussed will generally suit several observers of average sight; for near-sighted persons the eye-piece must be pushed in; for far-sighted persons it must be drawn out.

A micrometer^t is an appliance used for measuring small celestial distances. The simplest form is that known as the Reticulated^u Micrometer. It consists of an eye-piece of low power, having stretched across it a number of wires at right

^s *Month. Not.*, vol. xxx. p. 57. Jan. 1870.

^t *μικρός* small, and *μέτρον* a measure.

^u *Rete*, a net, reticulum, a little net.

angles to and at equal and known distances from each other. All that the observer has to do is to apply the eye-piece to the telescope, illuminate the field with a small lantern (if necessary, as is usually the case at night), and notice how many divisions cover the object whose size it is desired to measure. Knowing the value of each division, the solution then becomes a simple matter of arithmetic. To determine the value of the divisions—accurately focus the telescope on a star at or very near the equator; and note by a sidereal clock the time in seconds occupied by the star in crossing any convenient number of divisions, taking care that the star runs along some one wire. Multiply this by the co-sine of the star's declination, and the product will be the interval in equatorial seconds; this multiplied by 15 will be the space in seconds of arc. Then divide this by the number of the divisions made use of, and the quotient will be the average arcual value corresponding to each division.

Fig. 30.

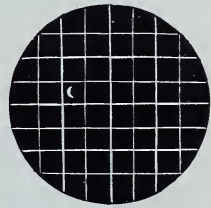

THE RETICULATED MICROMETER.

EXAMPLE.

Suppose that β Orionis (Decl. = $8^{\circ} 21.2' S$) is noted to take 49^s in crossing 4 divisions or squares of the micrometer. Then the calculation will be—

Log. 49	=	1.6901961
Log. cos. $8^{\circ} 21.2'$	=	9.9953680

Log. Interval in Eq. secs. ...	=	1.6855641
Log. 15	=	1.1760913

Log. Interval in secs. of arc ...	=	2.8616554
\therefore Interval in secs. of arc ...	=	727.2''

which divided by the number of spaces traversed, namely 4, gives $181.8''$, or $3' 1.8''$ as the value of each. For practical purposes we might consider each of such squares to represent $3'$ of arc.

The Reticulated Micrometer in the form just described is at best but a crude contrivance, but there are other forms of it

capable of yielding more precise results by combining calculation with observation^x.

The *Parallel-wire Micrometer*, the micrometer in most general use, may, in its elementary form, be thus described:—Two spider lines of wires are so mounted parallel on sliding frames that by suitable mechanism of screws, &c. they can be made to coincide

Fig. 31.

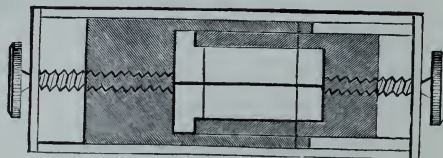

THE PARALLEL-WIRE MICROMETER.

with each other, or to separate by a small distance. The revolutions of the screws serve to afford a measure of the angular distance travelled over when the angular value corresponding to one revolution is known.

This apparatus is placed in the focus of the object-glass of the telescope so that the eye when it views the object a measurement of which is desired, is enabled (by suitable illumination if necessary, as above) to see the wires clearly. Supposing a comet is visible, and the observer wishes to measure the diameter of its head, all he has to do is to bring the two wires together on one side of the comet, and then to turn one of the screws until the wire moved is brought to coincide with the other margin of the comet: the number of turns and parts of a turn necessary to effect this is a measure of the angular diameter of the object.

To determine the value of a revolution of the screw—separate the wires by any convenient number of revolutions, and turn the telescope on an equatorial star: note the time in seconds occupied by the star in passing from one wire to the other; multiply this by the co-sine of the star's declination, and the

^x See Challis, *Lectures on Pract. Ast.*, p. 381. Mr. N. M. Mann has described a micrometrical contrivance capable of being made by amateurs for their own

use which seems to deserve a trial. It is described at length and its philosophy is discussed in the *Sidereal Messenger*, vol. iii. p. 10. Feb. 1884.

product will be the interval in equatorial seconds. This multiplied by 15 will be the space in seconds of arc. Then divide this by the number of the revolutions of the micrometer-screw, and the quotient will be the arcual value corresponding to each ^v.

Inasmuch however as it often happens that the greatest accuracy is required in the case of the Parallel-wire Micrometer, the value of its divisions is usually obtained from observations of the Pole Star, in the manner now to be pointed out. Separate the wires by any given number of revolutions, and note the interval in seconds occupied by the passage of Polaris between them. This interval (as Polaris describes a sensible curve, and not, like an equatorial star, a straight line in the field of view) we must convert into arc. Then to the log. sin of this arc we must add the log. cosine of the declination of Polaris; and the result, suppressing 10 from the index, will be the log. sin. of the equatorial interval in arc. Dividing this by the number of revolutions of the micrometer head we shall obtain the value of one revolution: and again dividing by 100, we shall obtain the value of a single division of it. On May 21, 1860, the wires of a micrometer were separated by 20 revolutions of the milled head, and Polaris was found to occupy exactly 29^m 47^s in its transit from one wire to another. Thus—

$$\begin{array}{r}
 \begin{array}{cccc}
 m & s & o & ' \quad '' \\
 29 & 47 & = & 7 \quad 26 \quad 45; \sin \quad 9.1125676 \\
 \text{Decl. of Polaris} = & 88 & 33 & 47; \cos \quad 8.3992718 \\
 & & & \hline
 11 & 10.294'' & & \sin \quad 7.5118394
 \end{array}
 \end{array}$$

And $\frac{670.294''}{20} = 33.5147''$, which was the value of one whole revolution of the micrometer head; while, of course, $0.335147''$ represents that of a single division of it.

Another convenient method of determining this value is practised as follows:—Take a foot-rule and place it at right angles to the optical axis of the telescope, at a distance, say, of

^v The principle of this calculation is identical with that involved in the determination of the value of a square of a reticulated micrometer. I have therefore deemed a separate "example" unnecessary.

100 yards, and observe how many turns and parts of a turn are required to include its length. Ascertain by calculation the angle subtended by the rule, at the distance at which it is placed. Then if a be the angle subtended, and n the number of turns, v , the value of the same, will be represented by the following simple equation—

$$v = \frac{a}{n},$$

which is merely the former rule given in another shape. In the case assumed of the foot-rule, a is $11' 27.5''$ —a fact which it may save trouble to the reader to have stated in this place.

As constructed for use with a large telescope, the parallel-wire micrometer (the above description of which merely takes cognizance of fundamental principles) is a somewhat elaborate piece of apparatus. Spiral springs are inserted between the frames and the sides of the rectangular metal box which protects the more delicate parts, for the purpose of assisting the screws in their work of driving inwards the frames which carry the wires. On one side of the field of view is a metal comb or notched scale of teeth, which correspond in size to the threads of the screw. Every fifth notch is cut deeper than the rest, and they are numbered from zero at the centre by tens in each direction. The zero is represented by a small circular hole, and every tenth notch has smaller circular holes drilled under it corresponding in number to the decades of teeth above. The spider lines or wires coincide at zero. The screws have generally about 100 threads to the inch, and near their ends (which are milled-headed) are small circles graduated to 100 equal parts; it follows that the motion of the head through one of these divisions advances the wire through $\frac{1}{10000}$ of an inch. It will be readily understood, therefore, that with a micrometer thus constructed angles of very minute amount may be subjected to measurement^z.

The parallel-wire micrometer mounted so as to rotate at right

^z For an account of a modification of this instrument by Alvan Clark for measuring large arcs, see *Month Not.*, vol. xix. p. 324. July 1859.

angles to the optical axis of the telescope, and provided with a third and larger graduated circle concentric with the optical axis, becomes the *Position Micrometer*^a, which is used for measuring angles made with the meridian by lines joining double stars.

The method of observing such an angle may be thus briefly described. Make the line which is horizontal in Fig. 32 parallel to the equator by shifting it till the larger of the 2 stars passes

Fig. 32.

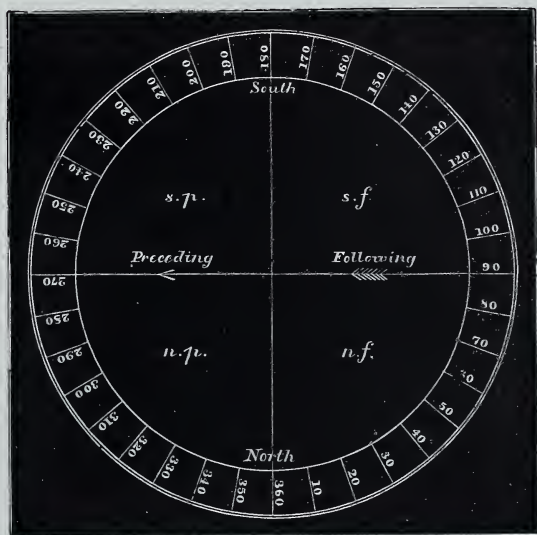

DIAGRAM ILLUSTRATING THE MEASUREMENT OF ANGLES OF POSITION.

along it during the whole of its passage across the field; revolve the position-circle through 90° , and the wire in question will then be parallel to the meridian: set the index of the position-circle to zero, bring the larger of the two stars under the wire, and resume the revolution of the circle from left to right, till the wire cuts the other star: read off the position-circle, and the reading will be the angle made with the meridian by the line joining the two stars. Angles of position are measured from the North round by the East, but since eye-pieces invert objects, North becomes South, and therefore the progression is from left to right, or contrary to the motion of the hands of a watch.

^a Described fully in Simms's *Achromatic Telescope*, p. 57.

The diagram may be taken to represent at one and the same time the graduated circle and the field of view, the latter distinguished into 4 quadrants: north-following, south-following, south-preceding, north-preceding. It should be added that generally 2 wires are used for determining angles of position, the stars being brought carefully between them; by this plan a more accurate result may be obtained than with one wire *covering* the stars.

The *Duplex Micrometer* invented by Grubb is intended to measure the distance and positions of stars which are too far apart to allow them to be brought

Fig. 33.

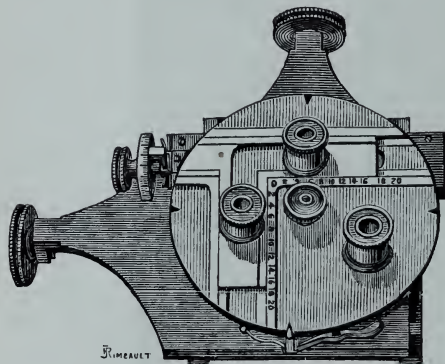

THE DUPLEX MICROMETER.

into the field of an ordinary micrometer. A plate of glass about $2\frac{1}{2}$ in square is ruled with 21 lines in one direction one-tenth of an inch apart, and 2 lines in the other direction 2 in apart. The extreme lines of the set therefore form a perfect square of 2 in. These lines are ruled with

exceeding accuracy and care, but any errors that remain either as to distance or want of perfect squareness can be ascertained.

Along one side of the square is mounted a micrometer frame in the ordinary way, actuated by a screw of 100 threads to the inch. This micrometer frame carries eleven lines corresponding exactly to each alternate line in the glass reticule, so that when the first spider line is made coincident with the first diamond line on the glass, the last spider line will be coincident with the last line on the glass, and each of the spider lines will be coincident with all the odd numbers of diamond lines, 1, 3, 5, 7, 9, 11, 13, 15, 17, 19, 21. Over this glass plate is placed a brass cap in which two eye-pieces are mounted, one sliding in a groove at right angles to the other; so that while one has its journey backwards and forwards on the horizontal line, the other has its

journey on the vertical line, according as the cap is placed, for the cap is capable of rotation to meet various circumstances. In using the instrument the two stars are brought on the horizontal line, and the distance measured from centre to centre along that line. This distance is measured by counting the number of spaces on the glass, adding the residue as measured by the micrometer screw. Thus the screw is never used for larger measures than one-tenth of an inch, and therefore errors of screw and temperature errors are much reduced. In bisecting, one star is brought into the field of one eye-piece, and a bisection is made with one of the diamond lines by moving the micrometer by one or other of its slipping piece screws. Then the other eye-piece is moved till the second star is seen, and a bisection is made with the nearest spider line by moving the micrometer head. Then the eye can be moved back to the first eye-piece, and the bisection checked, and again back to the second eye-piece. When it is seen that both are satisfactory the measure can be read off. The next stage in the operation is to turn the micrometer round till the horizontal line becomes parallel to the path of apparent motion of the star. This is easily found by stopping the clock and allowing the star to run along the horizontal wire. Now the other star will be found to cross the vertical line somewhere, while the first star is on the horizontal line. This second star is then bisected on the vertical line, while the first star is bisected by one of the spider lines; thus the difference in right ascension is found. We have then two sides of a right-angled triangle, whence of course the other elements can be ascertained.

It frequently happens in using a micrometer provided with wires which have to be illuminated by side-light that much inconvenience arises by reason of the light required for the wires interfering with the visibility of the object when that object is a faint one. To meet this difficulty, Mr. G. P. Bidder has devised a micrometer which, so far as the illumination of the field is concerned, is based on the reverse arrangement to that usually adopted; that is to say, instead of dark wires on a bright field he obtains bright wires on a dark field. This is brought about

in the following manner. The micrometer A, which only differs from the common Position-Micrometer in having no eye-piece in front of the wires, is placed above the telescope on a firm support B. The wires at W are illuminated by a lamp C, in front of them, which is carried on an arm capable of being altered in height and inclination as may be required to throw the light upon the wires. Opposite the wires is a compound tube D E, which is parallel to the telescope and excludes stray light. A diaphragm at the end nearest the wires reduces the aperture and assists in the exclusion of stray light. To this tube, but at

Fig. 34.

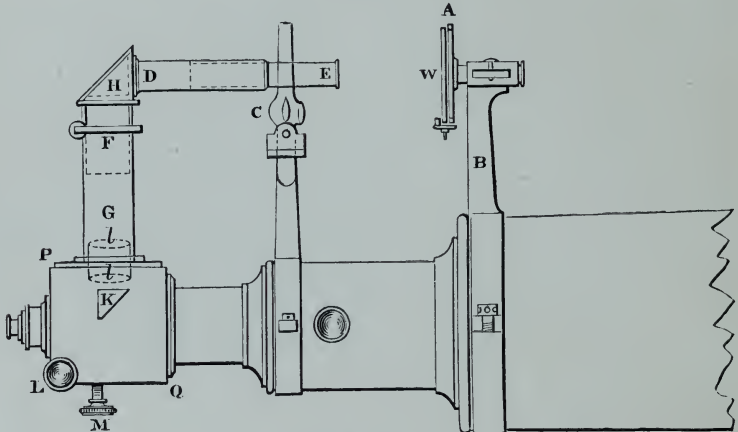

BIDDER'S MICROMETER.

right angles to it, is attached, in the way shown in the diagram, a short tube which slides into a fourth tube F G. This last tube is at right angles also to the axis of the telescope and is fixed to the square box P Q, which forms a prolongation of the draw-tube of the telescope.

At the intersection of the axes of the tubes D E and F G is placed a rectangular prism H, and within the tube F G a pair of convex achromatic lenses *ll*. Below these, and inside the square box P Q, is a second rectangular prism K, so placed as to be above the cone of rays passing from the object-glass to any point in the field. The light from the wires being thrown by reflection at the prism H on to the lenses, these form an image of the wires,

which, by adjustment of the position of the lenses, is made, after reflection at the lower prism K, to coincide with the principal focus of the object-glass. The distance from the wires to the lenses being greater than the distance from the lenses to the focus, the image of the wires is proportionally reduced in size and great delicacy of measurement is possible. The wires are seen in the field side by side with the stars to be measured and may be superimposed upon them, but being mere images cannot hide them. The light can of course be reduced until the wires are scarcely visible. In the case of extremely faint stars resort may be had to an additional expedient. An opaque bar fixed across a short tube is inserted at E in the tube D E, as near as may be to the wires, and so that the bar shall be at right angles to the wires. The effect is to intercept light from a portion of each wire and so produce a dark gap in the image of each. The image of the wires being moved in the field so that the stars to be measured appear in these gaps, they can then readily be measured. The prism K is so mounted that by turning one or both of the screws L M the image of the wires may be brought to any part of the field. It is essential to the accuracy of the measurements that the position of the micrometer and of the lenses, and the distance between them, should not be varied when once adjusted. By interposing coloured glass between the lamp and the wires they may be coloured if desired^b.

Burnham has devised a form of bright-wire illumination for micrometers which seems to offer some distinct advantages over previous arrangements. The main point is that the illuminating apparatus being attached to the Position Micrometer itself, and special provision having been made for the balancing of the parts, the observer is relieved from the duty of looking after the apparatus with his hands each time that he shifts the telescope.

B is the graduated head of the micrometer screw, and A another graduated head turning on the same axis for giving the whole revolutions of the screw; C is the head of a pinion attached to the plate under the micrometer-box, and gearing into

^b *Month. Not.*, vol. xxxiv. p. 394. June 1874. The bar mentioned above is apt to produce the illusion that a wire above

and below the gap created is not in one and the same straight line.

the teeth of the rigid circular plate containing the position circle, for moving the wires in position angle; D is the head of another pinion for sliding the eye-piece over the wires; E E' are heads

Fig. 35.

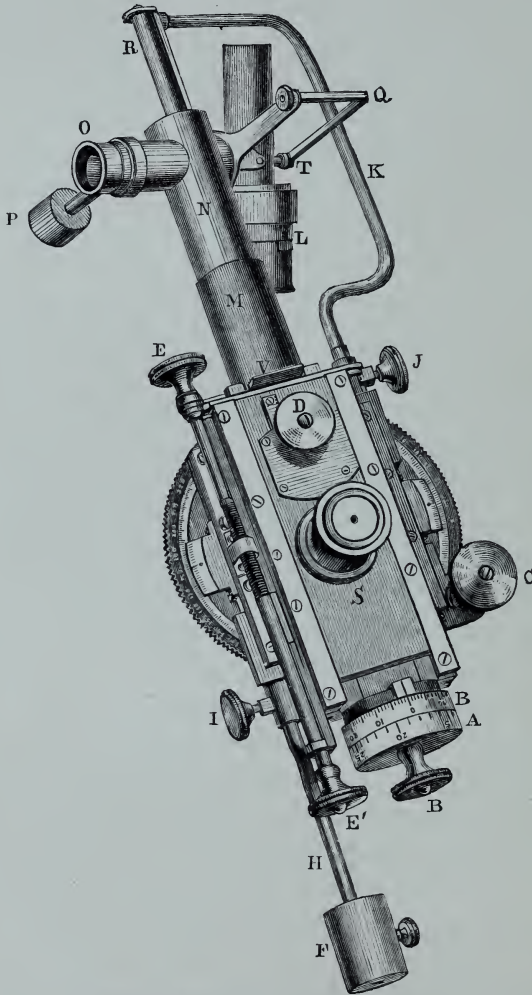

BURNHAM'S BRIGHT-WIRE MICROMETER USED AT THE LICK OBSERVATORY.

of the bisecting screw for moving the whole system of wires and the box S in a direction parallel to the micrometer screw and at right angles to the wires. Light from the lamp L is reflected by a mirror in N, and passes down that tube and through M,

and then through a hole in the end of the box to the wires. A condensing lens in N concentrates the light on the wires. On the opposite side of the wires, towards the micrometer head, a small reflector is placed which reflects the light back, thereby symmetrically illuminating the wires on both sides. The lamp swings freely on its axis in the line of OT, but always maintains a vertical position, whatever the direction of the wires or the pointing of the telescope. The tube N, with the lamp and its attachments, has an axle R supported by the fixed arm K. The bearings T, and axle of the lamp, are kept always horizontal by the counterpoise P. The tube M is fixed to the micrometer box, and projects loosely over N far enough to allow for the necessary movement of the box by the bisecting screw E. The supporting arm K is attached by the set-screw J, not to the box, but to the plate underneath it, so that the weight moved by the bisecting screw is not increased at all by the illuminating apparatus. Attached to the same plate, on the opposite side by a set-screw I, is the rod H, bent so as to be thrown forward out of the way of E' and B, with a weight F to balance the weight of the lamp attachments. The whole apparatus can be instantly detached from the micrometer itself when desired, by loosening the screws I and J. In the tube M is a slot V, in which can be placed a slip of coloured glass, held in any desired place by a light spring pressing against it. All or a part of the light can be made to pass through the coloured medium. The mirror in N is attached to a tube which slides into the tube O. By turning this tube by the milled edge at O, the inclination of the mirror may be varied, and the light reduced from the maximum, until the wires become invisible. The lamp can revolve freely through the bent arm Q; and the whole moveable part of the device, lamp, arm Q, and counterpoise P, can turn through the supporting arm K, the lamp at all times remaining vertical, and in exactly the same position with respect to the wires.

It is important to preserve the relative positions of the micrometer head, bisecting screw, and pinion C, as here shown. No other arrangement will be as convenient. In every possible

position of the micrometer, the necessary use of both hands at the same time will be found to be convenient and easy for the observer. Naturally the more delicate motions of the micrometer-screw and the pinion will be effected by the right hand, and the corresponding movement of the bisecting-screw by the left hand. When the micrometer box is anywhere near a horizontal position with respect to the observer (the wires at right angles to the line joining the eyes), C and E are used by the right and left hands respectively in measuring angles, and B' and E in measuring distances. When the box is more nearly vertical with respect to the observer, the head E' of the bisecting-screw will be worked by the left hand in each case. The convenience and practical value of this arrangement can only be appreciated by one who has used the old plans, and then tried this.

The practical working of the illumination has proved a success in every respect. Any object that can be seen under any circumstances, however faint, can be well and accurately measured. There is no such thing as a star too faint for measurement, if it can be seen at all. A very feeble light is sufficient to illuminate the wires perfectly for any object. Burnham believes that "far better results can be obtained by the use of bright wires in a large part of the most desirable and important double-star work, than is possible by the same observer using a bright field, and that sooner or later it will be generally used in all micrometrical observations^c."

Of the other micrometers in use the best known are the "Double-image" micrometer, and the "Ring" micrometer.

The Double-image instrument is similar in principle to the dynamometer. It consists of an eye-piece having 4 lenses, of which the second (reckoning from the object-glass) is bisected and has one of its segments moveable by a micrometer screw^d.

Fig. 36 represents a simple form of Double-image micrometer, devised by Browning, which he thinks removes some of the drawbacks which prevent the general use of micrometers based

^c *Month. Not.*, vol. xlii. p. 249. March 1882.

^d For further information on the use

of the Double-image micrometer see Challis's *Lectures on Practical Astronomy*, p. 309.

on the principle of double-images. It is formed simply by dividing an ordinary Barlow lens, each of the halves having a separate motion imparted to it by a micrometer screw with two reversed threads cut upon it. The inventor states that he has found the performance of a micrometer thus made to be even more satisfactory than he had anticipated. "It is compact, inexpensive, and possesses the great advantage that it may be used with any eye-piece^e."

Fig. 36.

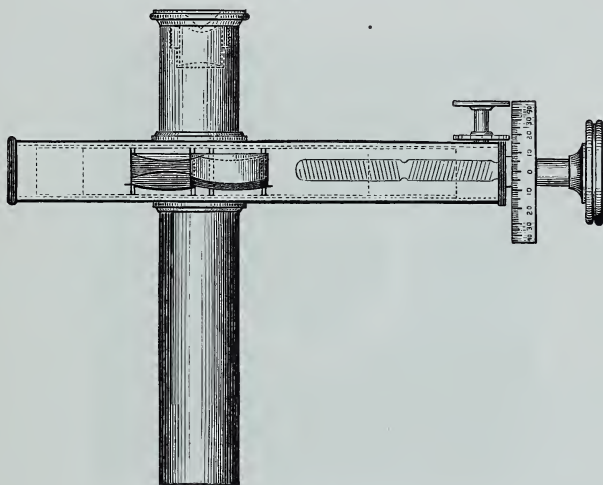

BARLOW-LENS DOUBLE-IMAGE MICROMETER.

The Ring micrometer is a German invention^f due to Fraunhofer, and it has not come much into use in England^g. The calculations involved in its use are very tedious, and therefore suit the German temperament. As no description of this simple form of micrometer occurs in any of the more popular works on astronomy, Loomis's description of its make and use may be given:—"It consists of an opaque ring, inserted in the focus of a telescope, and having a diameter somewhat less than that of the field of view. When the telescope is fixed in position, by

^e *Month. Not.*, vol. xxxii. p. 215. March 1872.

^g Loomis, *Pract. Ast.*, p. 115; Challis, *Lectures on Pract. Ast.*, p. 384.

^f *Ast. Nach.*, vol. ii. No. 28. March 1823.

observing the instants at which two stars pass the opposite sides of either the outer or inner circle of the ring their difference of Right Ascension and Declination may be computed, provided we know the diameter of the ring. The annexed figure represents the appearance of a ring suspended in the focus of a telescope, the field of view being represented by the circle, N W S E. Each star is to be observed when it passes behind the ring at L, when it reappears at A, when it disappears again at A¹, and when it reappears at M.”

Fig. 37.

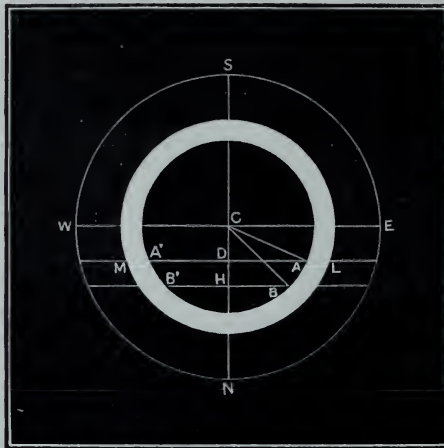

THE RING MICROMETER.

The letters in the woodcut which are not referred to in the above description relate to the computations as given by Loomis.

Chandler recommends the Square Bar micrometer suggested as far back as 1800 by Burckhardt, and much used by Graham at Markree, as having important advantages over the Ring micrometer without corresponding disadvantages^h. In its simplest form it consists of 4 flat bars of thin steel laid over each other in the form of a square and fastened by thin projecting ends to a circular diaphragm.

Observers laying themselves out for systematic observations of stars in order to form charts of particular localities will find a

^h *Mem. Amer. Acad.*, vol. xi. p. 158. 1885.

“zone reticle” of great service. This consists of a thin slip of transparent mica $\frac{1}{1000}$ of an inch or so in thickness, and placed in the focus of the eye-piece of a spider-line micrometer. On this are graduated divisions to represent equal intervals of Declination, with other divisions at right-angles to the former to represent equal intervals of Right Ascension. The mica plate is attached to a diaphragm in the micrometer perpendicular to the axis of the tube and at the common focus of the object-glass and eye-piece. It is illuminated by a cross-light so as to show the divisions as bright lines on a dark field. The transparency of the mica allows the light of stars to mag. 12 inclusive to be transmitted to a sufficient extent to permit of observations whilst the divisions are illuminatedⁱ.

Other micrometers have been constructed, some optical, some mechanical in their principles, but it does not appear necessary to enter further into the subject than to say that the most important will be found described in the works mentioned in the note^k.

A very useful adjunct to a telescope, especially when it is intended to carry on micrometrical observations, is a *slipping-piece*. This is a framework fitting on one side into the tail-piece of the telescope and fitted on the other to receive the micrometer. As it is provided with screws which will impart to it motion either in altitude or azimuth (or in Right Ascension or Declination, as

Fig. 38.

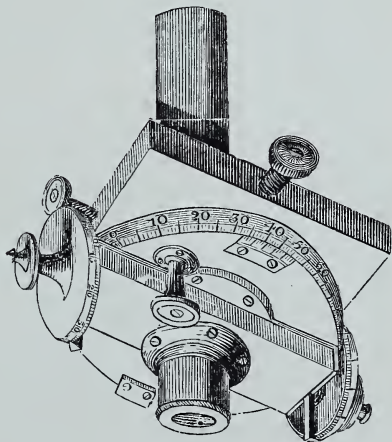

SLIPPING-PIECE.

ⁱ See an engraving and description of such an instrument in *Annals of the Harvard College Observatory*, vol. i. pt. 2. p. 4.

^k *Encycl. Brit.*, Art. *Micrometer*; Pearson, *Pract. Ast.*; Brewster, *Treatise*

on *New Instruments*, 1812; Arago, *Pop. Ast.*, Eng. ed., vol. i. p. 382 *et seq.* See also papers by Dawes in *Month. Not.*, vol. xviii. p. 58, Jan. 1858; vol. xxvii. p. 218, April 1867; *Mem. R.A.S.*, vol. xxxv. p. 137. 1867.

the case may be), an observer who uses it is able to bring any particular wire to cover any particular part of his field of view without the necessity of moving bodily the whole telescope¹.

For telescopes up to 5^{ft} or so in length, the tubes are generally made of brass, but for sizes larger than that, in consequence of the expense of brass, other materials are frequently employed, such as sheet-iron, zinc, or wood. The following is a description of a tube of a very strong and convenient style of manufacture, formed of veneers of mahogany.

“This tube was formed upon a core of dry well-seasoned deal planks, and turned down in the lathe to the following dimensions:—

Length of core	9 ft. 0 in.
Diameter, large end	0	$7\frac{7}{8}$
Do. small end	0	$5\frac{7}{8}$

“The core was well soaped to prevent the possibility of any portion of the glue adhering to it, and thereby rendering the removal of the tube difficult when finished. Upon the core a sheet of thick brown paper was wrapped, its edges being pasted together to serve as a foundation for the first veneer. The core was then brushed over with glue, and a veneer of mahogany then laid round it; a moveable caul made of double canvas was then laid round the veneer, and drawn up tightly by means of screws.

“This caul exactly fitted the taper of the tube, and its longitudinal edges were securely fastened to two strips of wood. In one of these strips, at intervals of about 5 inches, were inserted common bed-screws, moving freely through it, and screwing into corresponding nuts in the other strip. By this means the caul was screwed up tightly round the veneer, thereby ensuring a close contact between it and the core.

“The core was then placed over a stove-pipe, which extended along its whole length, and was slowly turned on its axis until it became sufficiently hot to melt the glue, which thus became equalised, while the superabundant quantity was squeezed out, a portion even permeating the veneer, owing to the pressure of the caul. The core was then set aside for two or three days to dry.

“Every successive veneer, prior to being laid on, was lined with a piece of thin calico, to prevent the veneer from splitting while being turned round the core. This calico was removed when the veneer was dry; after which the surface was prepared for another veneer, by being levelled over and freed from inequalities by the veneer plane. Each veneer was in a single piece, the joints being placed at alternate sides of the tube, and the grain of the wood reversed at every layer. A tube was thus formed of 8 thicknesses, the 7 inner ones being of Spanish mahogany, having stains or other faults which rendered them unfit for *fine* cabinet-work, and therefore of moderate cost (about 9*d.* per foot super.). The 8th was of the finest Spanish mahogany, and cost (on account of its great size) about 1*s.* 8*d.* per foot super. The

¹ See paper by Dawes in *Month. Not.*, vol. xxvii. p. 219. April 1867. This paper contains a good deal of information

about various kinds of micrometers, and many practical hints on making observations on double stars.

thickness of the tube when finished was $\frac{3}{8}$ of an inch. It was French polished on the outside^m.”

The preceding remarks apply chiefly to refracting telescopes. Reflectors of all sizes save the smallest are usually provided with open tubes, which are hardly tubes at all; rather, tubular frames. (See Fig. 71, p. 94, *post.*) This is to secure freedom from currents of air. ✓

^m F. Brodie, *Month. Not.*, vol. xvii. p. 33. Dec. 1856.

CHAPTER II.

TELESCOPE STANDS.

Importance of having a good Stand.—“Pillar-and-Claw” Stand.—The “Finder.”—Vertical and Horizontal Rack Motions.—Steadying Rods.—Cooke’s Mounting.—Varley’s Stand.—Proctor’s Stand.—Altazimuth stands for reflectors.—Brett’s Altazimuth mounting for reflectors.—Other forms of Altazimuth stands.—Interchangeable Altazimuth and Equatorial stands.—Smeaton’s block.

THE manner in which a telescope is mounted is a matter of much more importance than many people imagine. It frequently happens that a good glass is nearly or quite useless

Fig. 39.

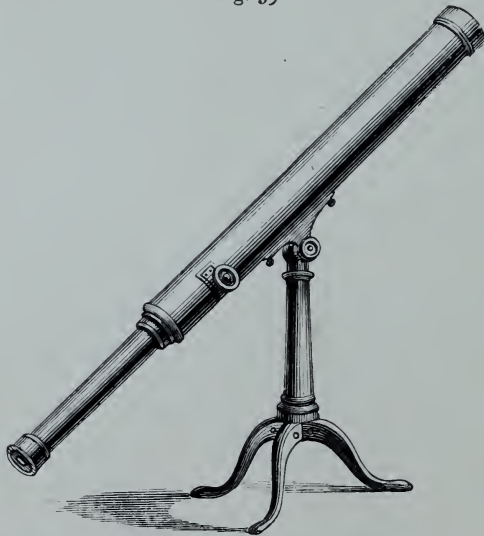

TELESCOPE MOUNTED ON A PILLAR-AND-CLAW STAND.

because it is provided with no proper stand on which it may be placed. It is far better for observers who are desirous of

deriving some benefit from the instrument which they purpose to obtain, to get one of smaller size and power, thoroughly well mounted, than to devote their resources to the purchase of some larger glass which is only to be hung up by ropes and spars, under which condition it would fail to possess, in the slightest degree, those most indispensable qualifications, steadiness and facility of movement.

Fig. 40.

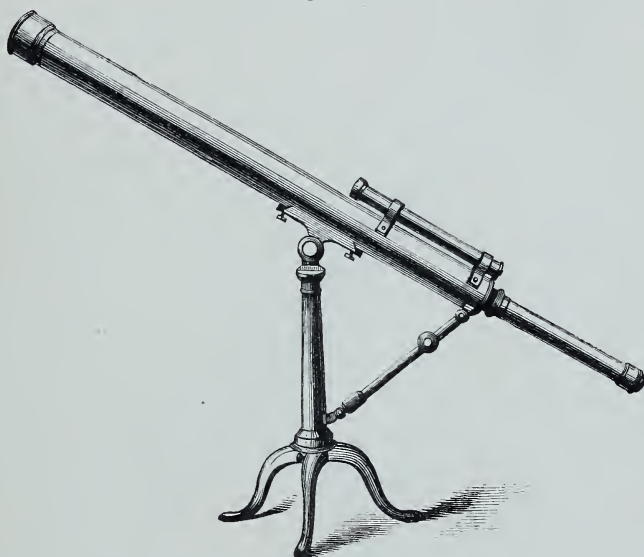

TELESCOPE MOUNTED ON PILLAR-AND-CLAW STAND, WITH FINDER
AND VERTICAL RACK MOTION.

The simplest form of stand is that known as the "pillar-and-claw," and is suited for telescopes of from 24 to 48 inches focal length. By its use the observer is enabled to impart to his tube 2 motions, one in altitude, the other in azimuth. The former, or vertical motion, is obtained by a joint at the top of the pillar; the latter, or horizontal motion, by a conical axis carefully fitted into the capital of the pillar by a nut and screw. The telescope is brought to a focus by a rack and pinion. Sometimes, especially in telescopes furnished with a long range of powers, a tube sliding easily within the tube to which the rack and pinion

is attached, and called a *tail-piece*, is employed for first getting an approximate focus.

Supposing several powers to be supplied to such an instrument, the observer is recommended to make use of the lowest to find the object he is in quest of: by a little care and practice he will be enabled to change the eye-piece for one of higher power, all the while keeping the object within the field of view.

The first addition to such an instrument as that I have just described, is a "Finder;" which is a small achromatic telescope mounted on the outside of the tube of the large one, the optical axes of both being parallel, and used for the purpose which its name implies. The eye-piece is of very low power, and consequently the field of view is extensive, and being furnished with 2 wires crossing each other at right angles (or better still with 3 crossing so as to leave an equilateral triangle in the centre of the field), it will happen (supposing the wires to be in good adjustment) that when an object is seen at the intersection of the cross wires in the finder (or in the centre of the triangle, as the case may be), it will also be in the centre of the field of the large telescope. Perfect parallelism between the axes of the 2 telescopes is obtained by the use of the screws in the collar which holds the eye-end of the finder, the method of using which will be obvious from inspection.

When it is desired to have greater precision, for the purpose of moving the telescope, than could be given by the hand, vertical and horizontal rack-motions are applied. ✓

The former consists of 2 or 3 tubes which slide one within the other, the largest being attached by a joint to the base of the pillar, and the smallest being secured to the eye-end of the telescope. The 2 larger tubes slide freely, but can be fixed in any position by a clamp; the smallest is moveable by a rack and pinion.

In cases where the horizontal rack-motion is applied, the construction of the pillar differs somewhat from that described at the commencement of this chapter. It consists, as in the former case, of an outside and an inside cone; but instead of the

telescope being attached to the inside cone, and that dropping into the outside one, the arrangement is reversed, and the telescope is fastened to the outside one, which drops *upon* the inner one. Upon the lower end of this fixed inner cone a ring is made to move stiffly, and in the edge of this ring teeth are cut, into

Fig. 41.



TELESCOPE MOUNTED ON A PILLAR-AND-CLAW STAND, WITH FINDER, VERTICAL AND HORIZONTAL RACK MOTIONS, (THE LATTER WORKED BY A HOOKE'S JOINT), AND STEADYING RODS.

which an endless screw, attached to the outer cone, works. When therefore the observer wishes to impart a rapid horizontal motion, he has only to apply to the telescope a force sufficient to cause the outside cone, together with the ring, to revolve upon

the inside one; but when a slow motion is desired, it suffices that the endless screw be turned, in which case the ring, in consequence of the friction, remains attached to the inside and immoveable cone.

Motion may be conveniently imparted in the horizontal direction by attaching to the endless screw a Hooke's joint mounted in a handle.

Fig. 42.



TELESCOPE ON STAND, WITH VERTICAL AND HORIZONTAL RACK MOTIONS.

To all telescopes of a greater length than 3^{ft} and which are mounted on a pillar-and-claw stand, steadying rods are a very desirable addition. They are generally 2 in number, and consist of 4 or more tubes sliding one within another, their ends terminating in universal joints fixed to the object-glass end of the telescope and the 2 front "claw-legs" respectively. (Fig. 41.)

Fig. 42 represents a telescope and mounting, by Cooke, of

York, which is extremely well adapted for general purposes, astronomical and terrestrial.

A contrivance known as *Varley's Stand*^a is sometimes used for telescopes longer than 4^{ft}; it is a very ungainly affair, and the regular equatorial stand is recommended for instruments too

Fig. 43.

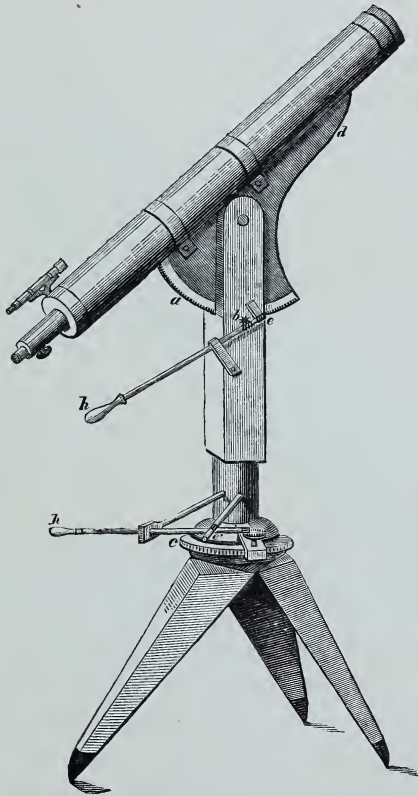

TELESCOPE STAND, WITH MOTION IN ALTITUDE AND AZIMUTH.
(Devised by Proctor.)

large to be conveniently placed on one of the pillar-and-claw construction: indeed an equatorial may be said to be indispensable for the satisfactory conduct of observations in sidereal astronomy: without it, much valuable time is apt to be lost in

^a W. Simms, *The Achromatic Telescope*, p. 31.

finding the objects sought after, which would be far more profitably spent in scrutinising a larger number found at once by the facilities afforded by graduated circles, &c.

Fig. 43 represents a mounting, having altitude and azimuth motions, devised by R. A. Proctor. The slow movement in altitude is given by turning the rod $h e$, the endless screw on which turns the small wheel at l , whose axle bears a pinion wheel working in the teeth of the quadrant a . The slow movement in azimuth is given in like manner by turning the rod $h' e'$, the lantern wheel at the end of which turns a crown wheel, on whose axle is a pinion working in the teeth of the circle c . The casings at e and e' , in which the rods $h e$ and $h' e'$ respectively work, are so fastened by elastic cords that an upward pressure on the handle h or a downward pressure on the handle h' at once releases the endless screw or the crown wheel respectively, so that the telescope is free to be swept at once through any desired angle either in altitude or azimuth. This method of mounting has another advantage—the handles are conveniently situated and constant in position; and as they do not work directly on the telescope, they can be turned without setting the tube in vibration^b.

Hitherto in dealing with the subject of stands for telescopes we have been considering exclusively the mounting of Refractors, but Reflectors must not be passed over.

Fig. 44 illustrates a form of altazimuth mounting for Newtonian Reflectors which has been devised by J. Brett, and which presents some convenient peculiarities. The telescope is supported at both ends. The pivot on which it revolves is placed at the lower end, and the power by which it is moved is applied as far as possible from the pivot, that is to say at the eye-end. This arrangement tends to reduce to a minimum all vibration due to the wind or to any accidental cause. The whole instrument, treated as one piece of apparatus, may be described as a tripod with a moveable apex: and the main peculiarity consists in the means by which motion is imparted

^b *Pop. Sc. Rev.*, vol. v. p. 462. Oct. 1866.

to the apex, whereby different parts of the sky can be scanned in succession. The tube itself of the telescope forms one leg of the tripod, the other two legs being each attached to the tube at the eye-end. As the telescope has a given length which is invariable, it is obvious that it may be made to stand at any angle to the horizon by lengthening or shortening the other two

Fig. 44.

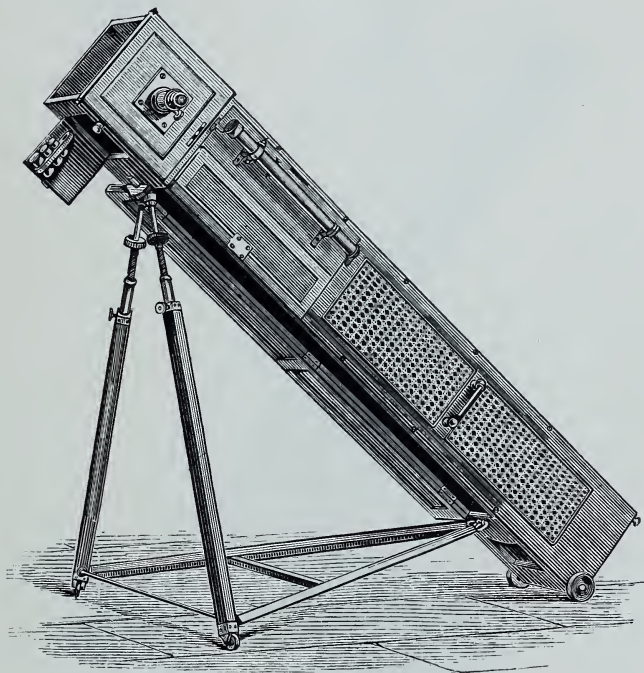

ALTAZIMUTH MOUNTING FOR REFLECTORS.

(Devised by Brett.)

legs. Further it is evident that if these two contractile legs be lengthened or shortened equally, the third leg (the telescope) will be moved in altitude only; that if merely one of them be lengthened or shortened the telescope will describe an arc of a circle; finally, that if one leg be lengthened and the other shortened at the same rate, a lateral movement will be communicated to the apex: in other words the telescope will move in azimuth only. Provision may be made for quick and slow

motion both in altitude and in azimuth; besides which there may be a slow motion in a circular direction, which motion may be made equatorial by placing the speculum end or pivot of the telescope on some support as many degrees higher (in altitude) than the casters of the other two legs, as shall equal the

Fig. 45.

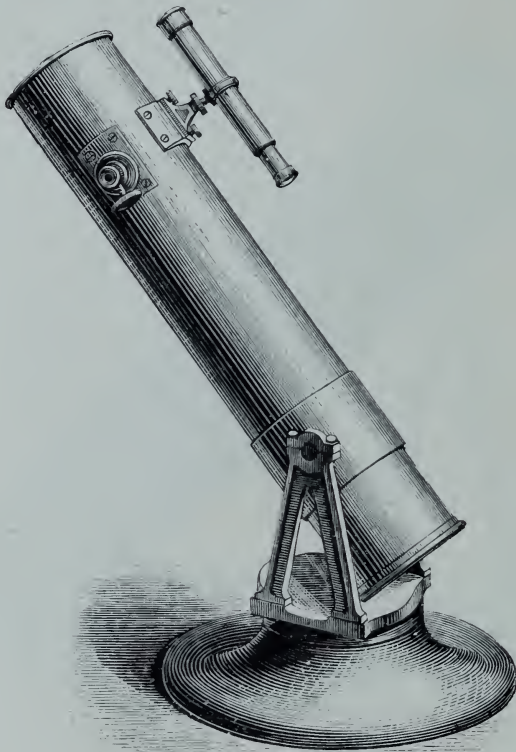

ALTAZIMUTH MOUNTING FOR A SMALL REFLECTOR.

latitude. The foregoing description aided by the engraving will enable the reader to comprehend generally Mr. Brett's design: for further details his paper must be consulted^c.

In Fig. 45 we have the simplest form of altazimuth mounting for a Newtonian reflector, which may be said to be the only form of construction much in use now-a-days for astronomical

^c *Month. Not.*, vol. xxxii. p. 294. June 1872.

purposes. Gregorian and Cassegrainian reflectors may, it is obvious, be regarded, so far as their mounting is concerned, as if they

Fig. 46.

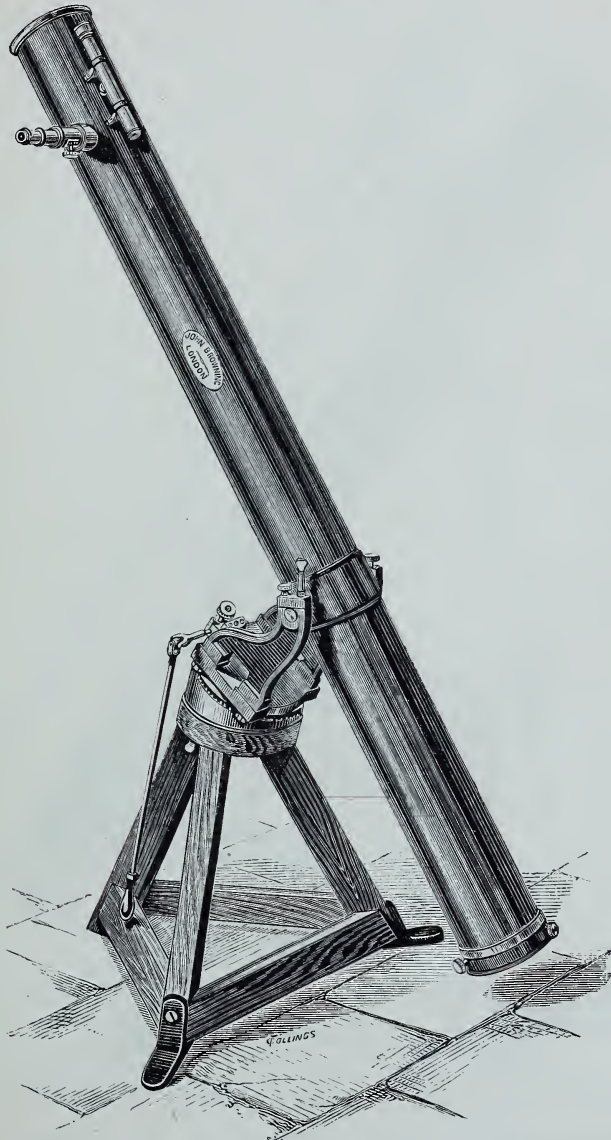

ADJUSTIBLE ALTAZIMUTH OR EQUATORIAL MOUNTING FOR A MEDIUM-SIZED REFLECTOR.

were refractors. An instrument such as that contemplated in Fig. 45 should, if well made, be self-balancing in any position,

Fig. 47.

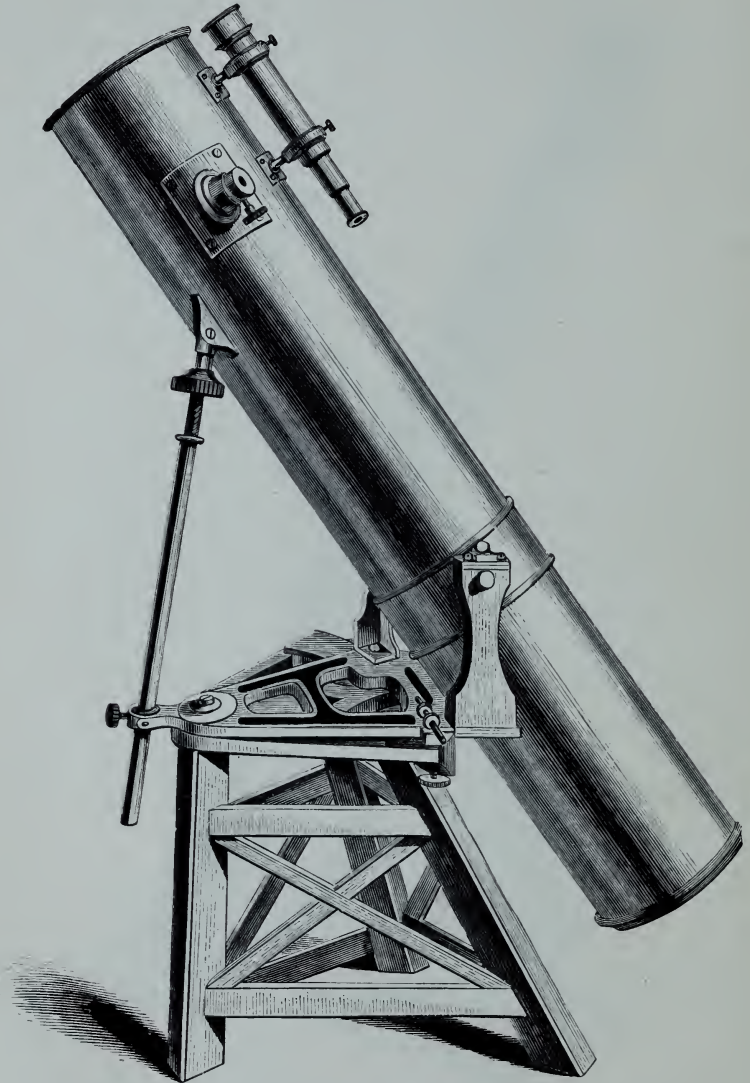

ALTAZIMUTH MOUNTING FOR A LARGE REFLECTOR. (*By Browning.*)

but 4, or at most 5, inches should be the diameter of the speculum mounted in this particular and very simple fashion,

which is only adapted for instruments intended for use on a table, for instance, or on some extemporised stand at a window.

The first advance on the form of instrument just described is represented in Fig. 46. Here we have a stand with feet to rest upon the ground; motion in azimuth, convertible into equatorial motion by tilting the instrument bodily on one side by the aid of suitable adjusting screws; and a slow movement by means of an endless driving screw, with which a handle is connected by the intervention of a Hooke's joint.

Larger and heavier forms of altazimuth are represented in Figs. 47 and 48. These are adapted for mirrors of 6 inches diameter and upwards; at the same time instruments of such dimensions should by preference be furnished with equatorial mountings. Each of these altazimuths has a quick and a fine screw motion alike in altitude and azimuth. A reference to Fig. 48 will enable the reader to see how these motions are obtained. On unclamping the small screw which is visible on the left of the engraving, and which projects in a nearly horizontal direction, the telescope can be raised or lowered rapidly through an altitude of about 70° . On reclamping the small screw the telescope will become fixed, but a further motion of elevation or depression can be imparted to it, within certain moderate limits, by turning the milled-edge disc which is shown near the top of the altitude-rod and just below the telescope. To move the telescope horizontally to any considerable extent, short of lifting the stand bodily, it is necessary to release a clamping screw which is attached to the tangent screw just above the horizontal arc which forms the top of the stand. On reclamping, a fine horizontal motion can be obtained by turning the tangent screw, to the end of which a long handle for the use of the observer is attached by means of a Hooke's joint. The telescope is equipoised on trunnions, and can be lifted from the stand at pleasure. Occasionally these stands are fitted with a wheel at the foot of one leg, and a handle on each of the other legs, and thus the whole instrument can be moved about like a wheel-barrow.

It is often desired to use an instrument for both terrestrial and astronomical work. For terrestrial purposes any form of

Fig. 48.

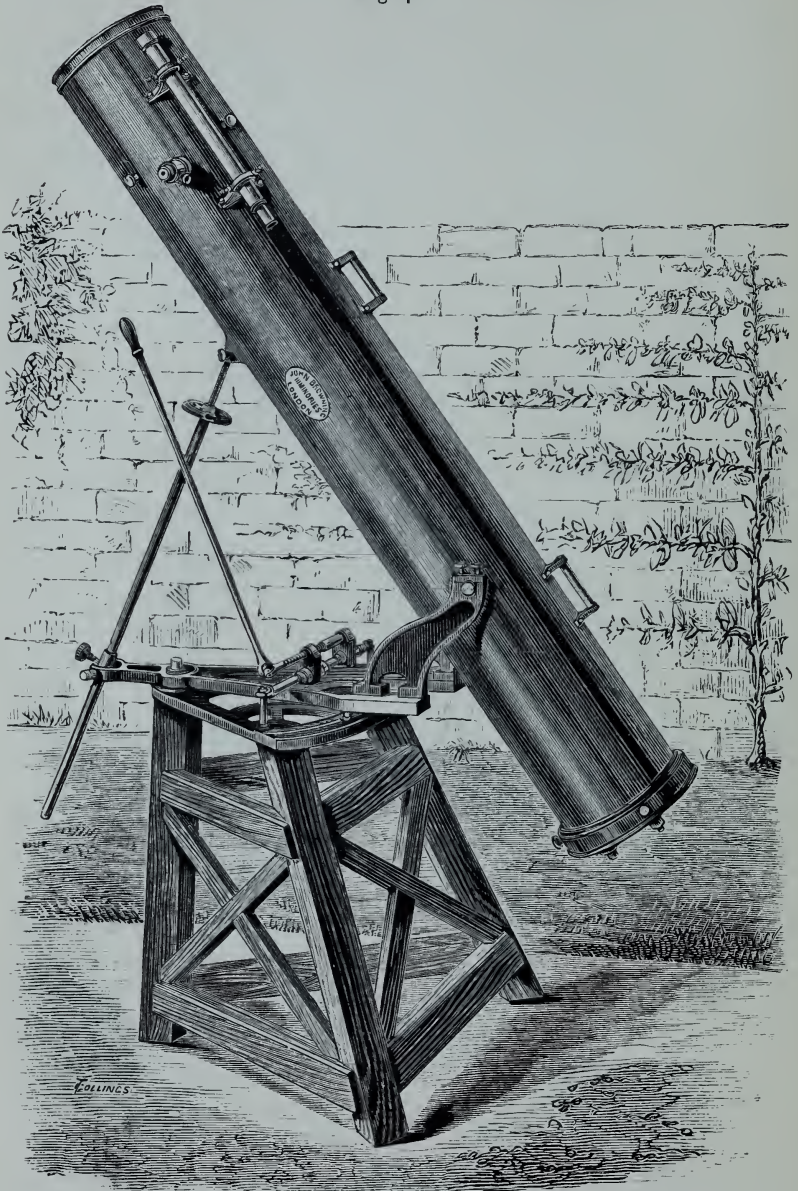

ALTAZIMUTH MOUNTING FOR A LARGE REFLECTOR. (By Browning.)

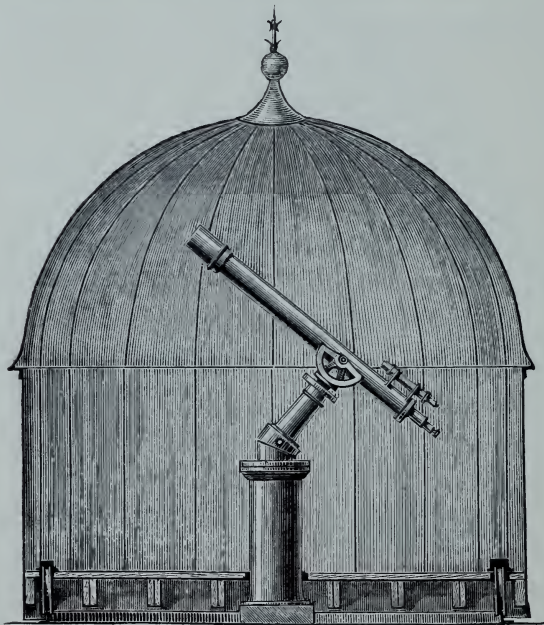
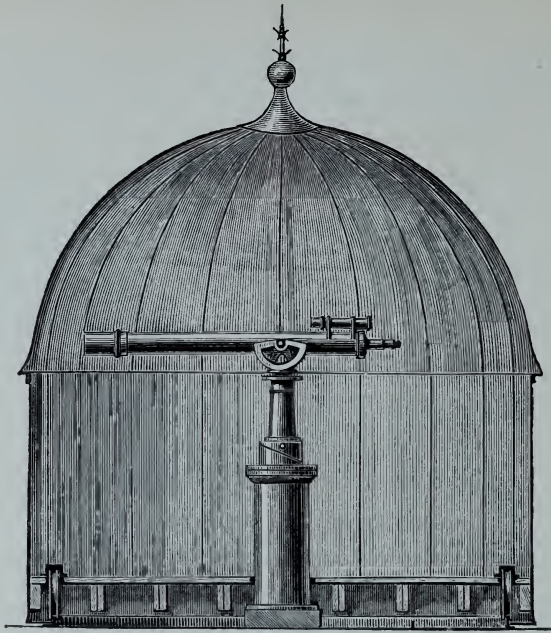

GRUBB'S NEW FORM OF TELESCOPE MOUNTING EASILY INTERCHANGEABLE FROM ALTAZIMUTH TO EQUATORIAL.

mounting but the altazimuth is objectionable, while on the other hand the difficulties and inconvenience of using an altazimuth for astronomical work are well known to those who have tried it. It is highly desirable, in case of an instrument being required for such a dual purpose, that its mounting should be such as to be easily convertible from an altazimuth to an equatorial, and *vice versâ*. The old "Smeaton block^d" was formerly used for this, but was only suitable for small instruments, as the whole pillar had to be unbolted and lifted bodily half round on its base, which was inclined to half the co-latitude of the place, so that placed in one position the pillar was vertical; in the other it was inclined to the proper latitude. This operation was dangerous and tedious, and, if the instrument was of any size, impossible to be effected by one person. In the form of mounting however, figured in Plate IV., the change is effected by simply taking hold of the two handles and turning round the pillar on its inclined base half a turn, until, in fact, it stops against a "banking pin"—an operation which in telescopes up to 5 or 6 inches aperture, can be performed with perfect safety, even in the dark, by one person in a few seconds.

^d Described in Pearson's *Practical Astronomy*, vol. ii. p. 42.

CHAPTER III.

THE EQUATORIAL.

Brief epitome of the facts connected with the apparent rotation of the Celestial Sphere.—Principle of the Equatorial Instrument.—Lord Crawford's plan for converting an Altazimuth into an Equatorial.—Two forms in general use.—Description of Sisson's form, and of the different accessories to the instrument generally.—Description of Fraunhofer's form of Equatorial.—In what its superiority consists.—Types of Modern Equatorials of English, German and American manufacture.—Portable Equatorial Mountings.—Erck's Window Equatorial.—Equatorial mountings for Reflectors.—Universal Equatorial.—The adjustments of the Equatorial six in number.—Method of performing them.—Method of observing with the instrument, reading the Circles, &c.—Examples.

THE reader no doubt already understands that the celestial sphere has an apparent motion of rotation around certain imaginary points in the heavens termed the Poles, only one of which is visible from any given point on the Earth, the equator (in one sense) excepted; that the altitude of the Pole, or its angular elevation above the horizon, is equal to the latitude of the place of observation; and also that every star describes, apparently, a circular path around the Poles of the heavens, increasing in magnitude with the increase of the angular distance of the star from one Pole up to a distance of 90° or a quadrant, after which it again diminishes towards the opposite Pole.

If we incline the pillar-and-claw stand, already described, in such a manner that the vertical axis shall point towards the Pole, and thus be parallel to the axis on which the sphere is supposed to revolve—in point of fact, if we give the pillar an inclination equal to the latitude of our station—it will clearly

follow, that a single motion of the telescope, namely one of rotation about that inclined axis, will cause the line of sight (called also the optical axis) to trace upon the sphere a circle corresponding to those in which the heavenly bodies appear to move, these circles increasing or diminishing as, by moving the telescope upon the stand or horizontal pivot, we increase or diminish the angle between the line of sight and the first or inclined axis; just as the circles which the heavenly bodies themselves describe increase or diminish according as the polar distance increases or diminishes.

A pillar-and-claw stand placed in the above-described position constitutes a simple Equatorial, though in the construction of one specially designed to serve that purpose numerous alterations of mechanical detail are introduced. All Equatorials in fact are constructed on principles similar to those just set forth, but they vary in the manner in which those principles are worked out.

Before however proceeding to describe these it may be worth while to call attention to a suggestion made by Lord Crawford for the temporary conversion of a telescope mounted with vertical and horizontal motion into an equatorial by the addition of a bar of metal or wood.

At any convenient distance below the horizontal or altitude axis of the instrument let a bar be fixed at right angles to the pillar or azimuth axis. In the bar there should be a V-shaped slot, through which a string or wire may slide, capable of being clamped by a screw pressing it into the angle of the V.

Let the bar project in the plane of the meridian to such a distance that the angle contained between the bar and a line drawn from the V-shaped slot to the centre of motion of the altitude axis may be equal to the latitude of the place of observation. In other words, let the distance of the angle of the V-shaped slot from the central line of the pillar of the instrument be equal to the distance from the upper side of the bar to the centre of motion of the altitude axis multiplied by the cotangent of the latitude of the place of observation.

The object-glass end of the telescope should now be connected with the V-shaped slot by means of a fine wire or string, and a weight may be attached at the other end of the wire in order to keep the wire always stretched. On moving the telescope while the wire remains clamped it will be found, as is evident, that the

Fig. 50.

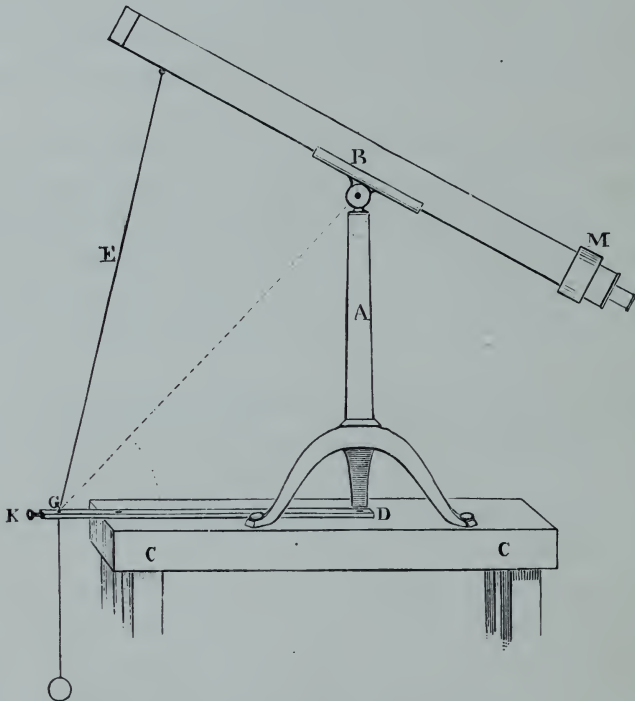

CONVERSION OF PILLAR-AND-CLAW STAND INTO EQUATORIAL AS WORKED
OUT BY THE EARL OF CRAWFORD.

REFERENCES.—A, stand ; C, table ; E, controlling line ; angle DGB=latitude of place ; B, centre of alt. motion ; DK, rod ; K, binding screw to clamp the line E ; M, weight to keep E tight.

telescope can only move in a parallel of declination. Each time that it is wished to follow a different star, the wire must be unclamped and the telescope re-set. The equatorial motion thus produced will be found to be sufficiently accurate for all ordinary purposes^a.

^a *Month. Not.*, vol. xxxvii. p. 1. Nov. 1876.

The forms of Equatorial are the English or Sisson's^b, and the German or Fraunhofer's; the latter is for many reasons to be preferred, but the general construction of the former being more readily comprehensible, will be described first.

Fig. 51 is a representation of an English equatorial; ab represents the polar axis; it is directed to the Pole of the heavens, and is supported in this position by the stone piers h, i , the uppermost portion of the latter, i , being generally made of cast-iron. The polar axis terminates in cylindrical pivots, which rest in sockets; and one of the sockets, usually the lower one, is provided with means for altering, for the purpose of adjustment, the direction of the polar axis. The declination axis (not shown, but to which the declination circle, g , is attached) passes through the polar axis, and rests upon collars; and, as it is necessary that the two axes should be at right angles to each other, the collar at the end opposite to that at which the telescope is fastened is adjustable by screws. The collar in which the telescope end revolves is held by pivots, which allow a lateral motion through a small arc, in order to prevent any strain being given when the adjustment at the other end is performed. tt is the telescope, fixed at right angles to the declination axis, and therefore moving in a plane parallel to the polar axis, great care being taken that the fastenings are perfectly rigid. The eye-end is furnished with means for the adjustment of the line of sight. This is done by means of a transit eye-piece in which a system of cross-wires is arranged, the line of sight passing through the intersection of the middle vertical with the horizontal wire, the whole system being moveable from right to left by screws provided for the purpose.

The angle between the line of sight and the polar axis is measured on the declination circle g , divided into degrees and fractions of a degree, and capable of being read off to minutes and

^b "In usual parlance, this species of instrument has Sisson's name attached to it, because Dr. Maskelyne considered the one made for him by that workman to be an improvement upon that made by

Henry Hindley at York, in 1741. But a polar-axis, though without the appendage of graduated circles, was used by Christopher Scheiner (author of *Rosa Ursina*) so far back as the year 1620."—*Smyth*.

seconds by 2 verniers placed at the end of the index-plate *x*, and carried round with the telescope. When the line of sight is

Fig. 51.

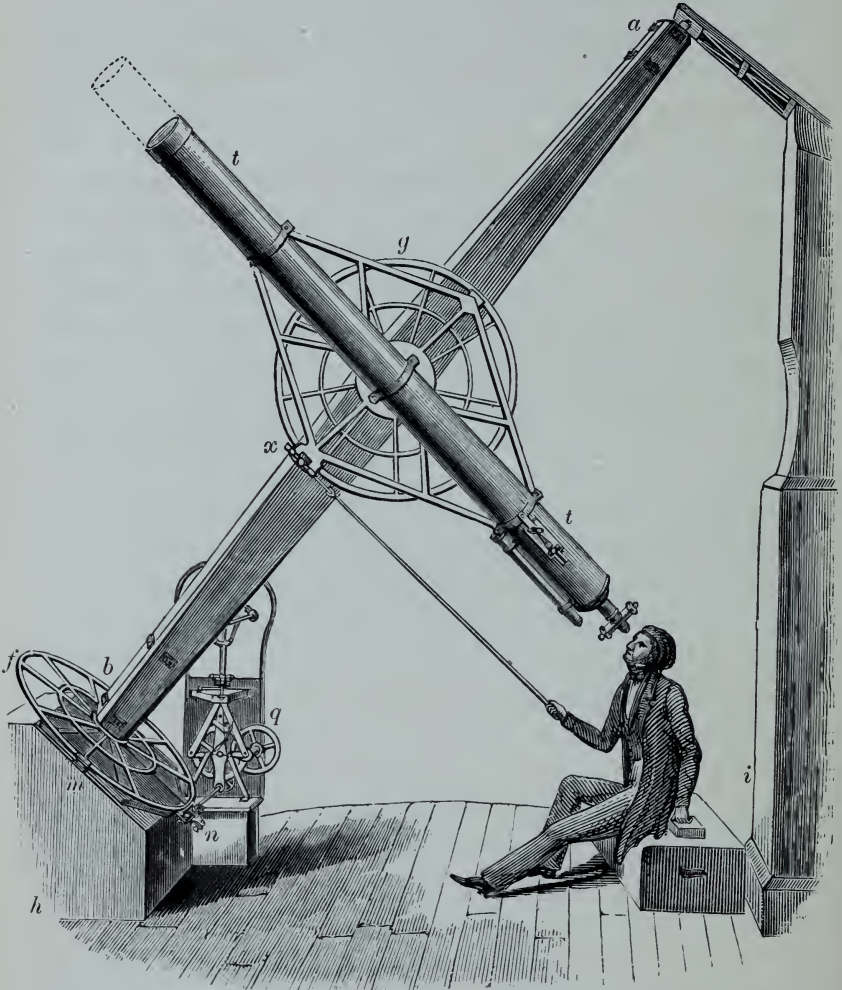

THE "ENGLISH" EQUATORIAL OF THE BEDFORD OBSERVATORY ERECTED
FOR W. H. SMYTH, 1829.

parallel to the polar axis, and consequently when, if the latter is in adjustment, it points to the Pole, the index-arrow on each vernier should point to 90° , and in order that each may do so,

means for adjustment are generally applied to the verniers themselves. A clamp and tangent screw near to x give the observer the power of fixing the telescope, or of moving it through very small arcs.

The angle through which the plane containing the line of sight and polar axis revolves is measured on the circle f , called the hour-circle, which is fixed to the polar axis^c, and divided to show portions of time—hours, minutes, and, by means of verniers (one shown at m), seconds, the hours being marked from I to XXIV. When the declination axis is horizontal, the zero arrows on the verniers should point to XII and XXIV, facilities for bringing about that coincidence being provided. The hour-circle has a female screw cut on its outer edge, in which an endless screw, which forms part of the clamp at n , is arranged to work so as to give a slow motion in Right Ascension, which may either be imparted by the observer himself, through the medium of a rod terminating in a universal joint, or by means of clockwork at q , if a uniform motion is desired for the purpose, for example, of following an object. In order that the 2 actions may subsist independently of each other, it is usual to attach the clock to one end of the tangent screw, and the rod for the use of the observer to the other. The screw is so mounted that when it is required to turn the telescope through a large arc, it can be thrown out of gear.

There are various expedients resorted to in practice, in connexion with the clockwork, and the method of making use of it, &c., which cannot here be specified in detail. Suffice it to say that clockwork is a most necessary adjunct where the telescope is designed for micrometrical and other work which requires both of the observer's hands to be at liberty.

^c In many equatorials the hour-circle turns on the lower pivot, and a different method of procedure is adopted. And it is to be understood generally that the description given in the text of the so-called English Equatorial deals only with the barest outline of the principles upon

which its working parts are put together. (See *Account of the Northumberland Equatorial and Dome*, by G. B. Airy, 4to. Cambridge, 1844; *Cambridge Observations*, 1838, vol. xv. p. xi.; also Challis's *Lectures on Pract. Ast.*, p. 288.)

A weight is placed at the end of the declination axis opposite to the telescope, to counterbalance the latter; and a spirit level,

Fig. 52.

GERMAN EQUATORIAL. (*By Horne and Thornthwaite.*)

to set the declination axis horizontal, is also provided, to be used when required.

The German or Fraunhofer's equatorial, so called from its inventor, the optician of Munich, is represented in Fig. 52.

There are two principal reasons why the German form of mounting is preferable to the English form :—(1) The telescope will reach every part of the heavens without interruption ; whereas it will be noticed that the upper support required for the polar axis of Sisson's stand necessarily interferes with the view of

Fig. 53.

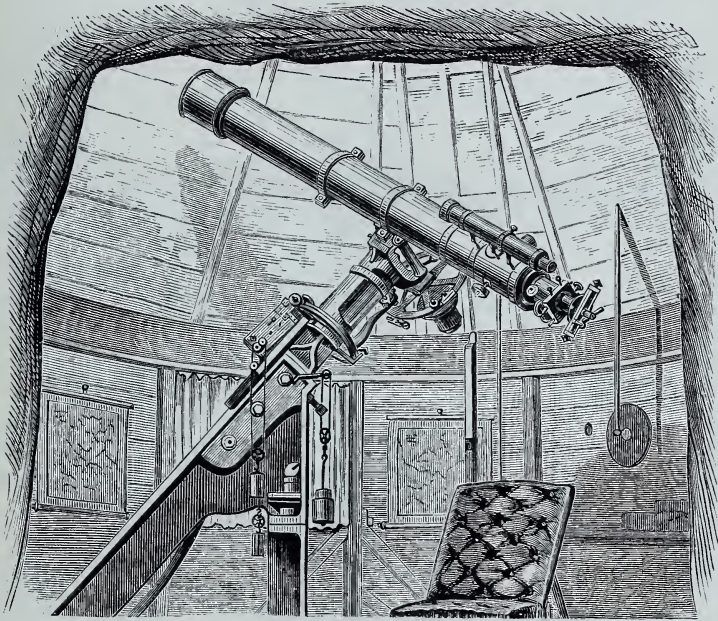

MODIFIED GERMAN EQUATORIAL.

objects at and below the Pole. (2) This stand requires but one pier easily erected, instead of two, the proper placing of which two, especially in the case of large instruments, occasions much labour and trouble, in order to ensure their being brought within the limits of the adjustments.

Fig. 53 shows a modification of the German form, contrived by Brodie. The polar axis is *fixed*, and the telescope is attached to a moveable cradle, which turns on the polar axis. The engraving is from a photograph of an instrument of $7\frac{1}{2}$ inches

aperture, formerly erected at East-Bourne, in Sussex, the stand of which is now in use at Mr. C. L. Prince's observatory at Crowborough. Figs. 55-67, which follow without particular description, may be said to represent the most modern forms of Equatorial turned out from the workshops of England, France,

Fig. 54.



EQUATORIAL CONSTRUCTED TO ALLOW OF CONSIDERABLE VARIATION IN LATITUDE.
(By *Bardou.*)

Germany and the United States. It will be observed of course that there is a strong family resemblance between them all: nevertheless it would be easy to suggest reasons for a preference in certain cases. For instance, beyond doubt the driving clock of an Equatorial should be inside, not outside, the pillar.

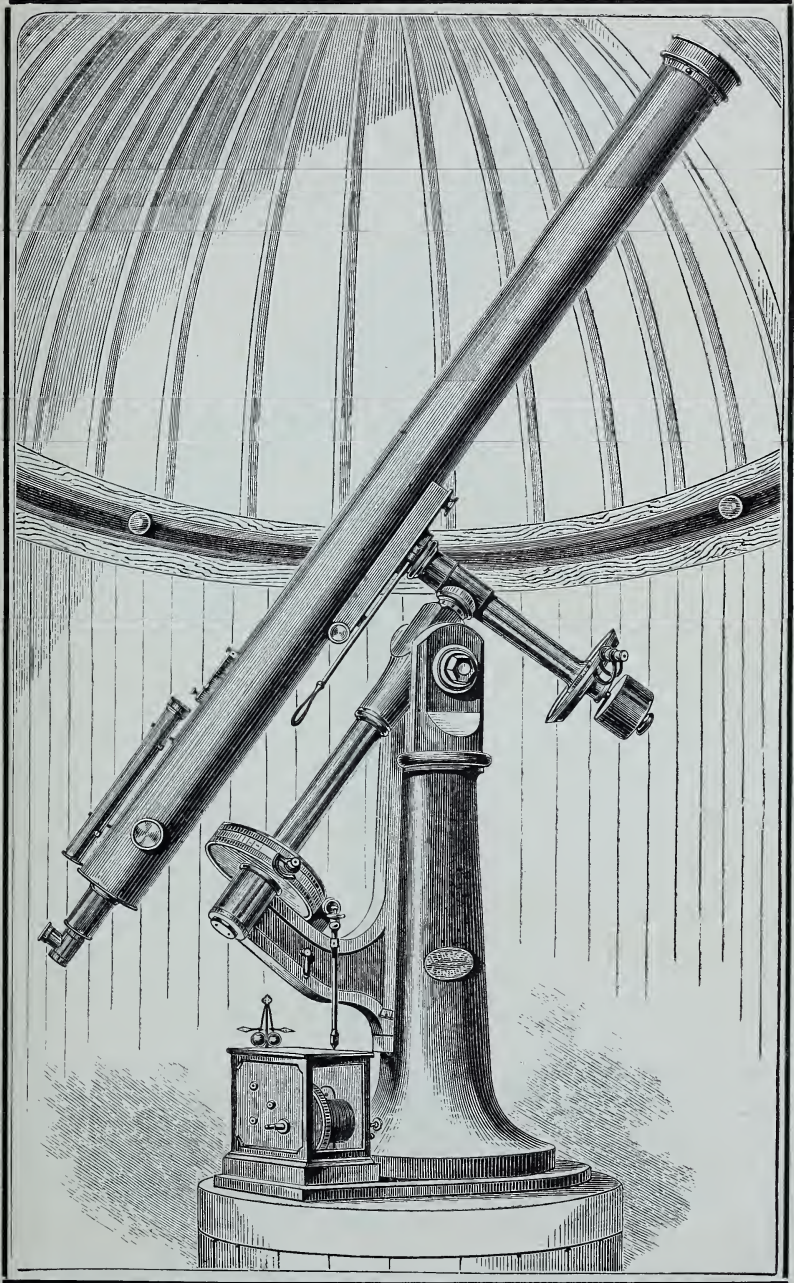

EQUATORIALLY-MOUNTED REFRACTOR.

Aperture, $4\frac{1}{2}$ inches.

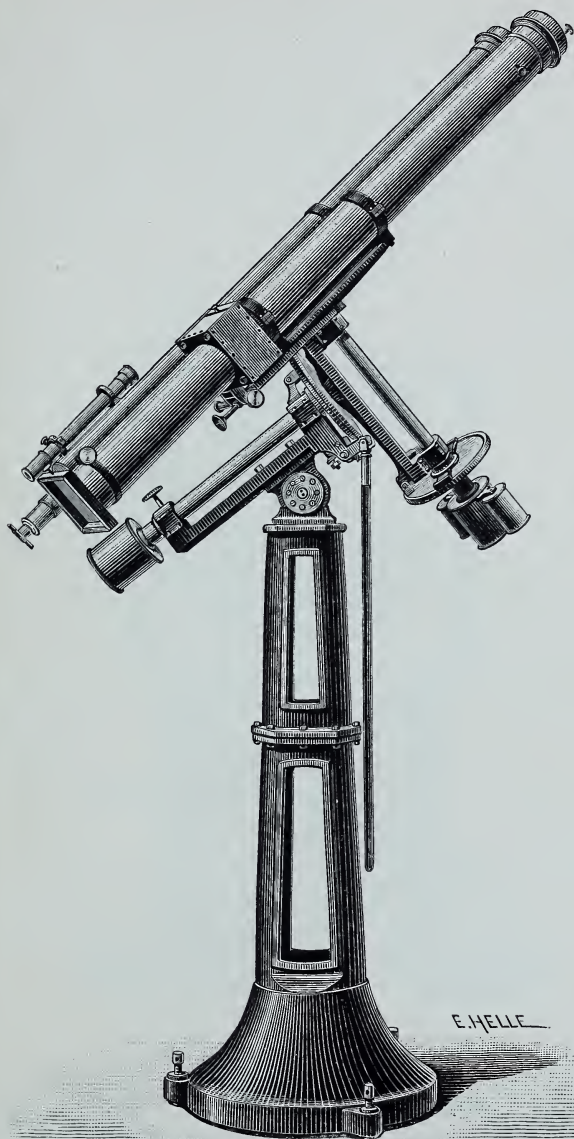

TWIN EQUATORIAL OF FRENCH MANUFACTURE.

(By Bardou.)

The Frontispiece to this volume and Plate XV. will give the reader an idea of the 2 largest and finest Equatorials in the world. Whether regarded as works of optical art or as specimens of engineering they cannot fail to awaken in a remarkable degree feelings of admiration for the genius of the men who planned and who carried to a successful completion 2 such giant structures.

Fig. 57.

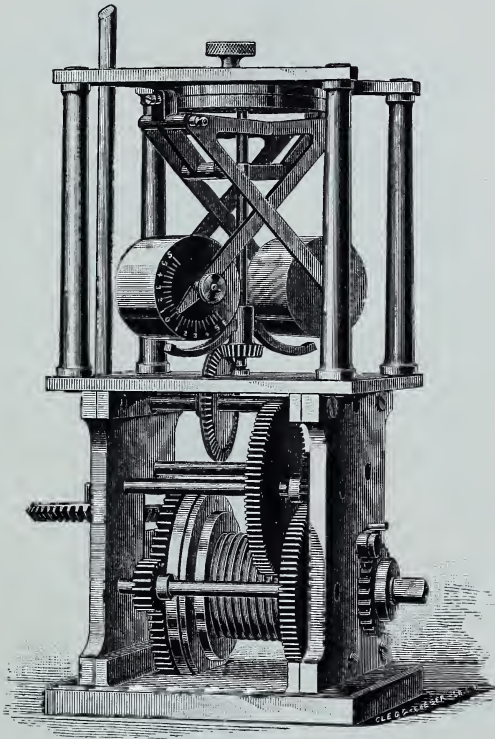

WARNER AND SWASEY'S DRIVING CLOCK.

Fig. 58 represents a very compact equatorial mounting constructed for Smyth by the elder Tulley, and which carried satisfactorily a $3\frac{3}{4}$ -inch object-glass. Though the motion in Declination was restricted within certain limits, yet it is easy to see that such a mounting if well made ought to be very steady.

Fig. 68 (p. 93) represents a portable equatorial stand devised by Erck^d for the use of persons who travel a good deal and who like to carry a small telescope of 2 or 3 inches aperture with them.

Fig. 58.

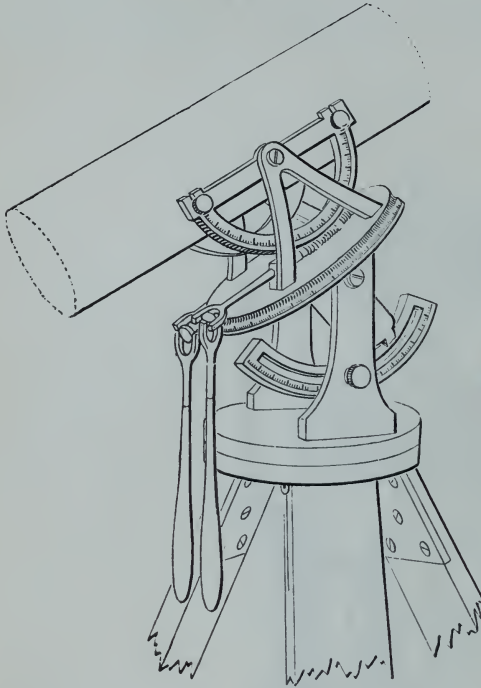

PORTABLE EQUATORIAL MOUNTING. (By Tulley.)

It can be fixed either to an English window-sash or to a French casement, or to an upright post. The apparatus consists of a small vice, from which hangs a vertical axis A: the frame which carries the polar axis moves on the axis A and so admits of adjustment in azimuth. When the mounting is to be attached to a vertical post, &c., the axis A is to be unscrewed from its block and inserted in another face of the cube at right-angles to the former. The mounting from which

the illustration is taken having been prepared for use only between Dublin and London the polar axis is suited for the latitude of about 52° N., and there is no direct provision for altering the inclination for another latitude; but if it is desired to have the means of adjusting for latitude, another joint with suitable screws can be introduced between the polar and vertical axes. All the screw heads and nuts are of the same size, and therefore they can be tightened and loosened by one wrench.

^d *Month. Not.*, vol. xxxviii. p. 124. Jan. 1878.

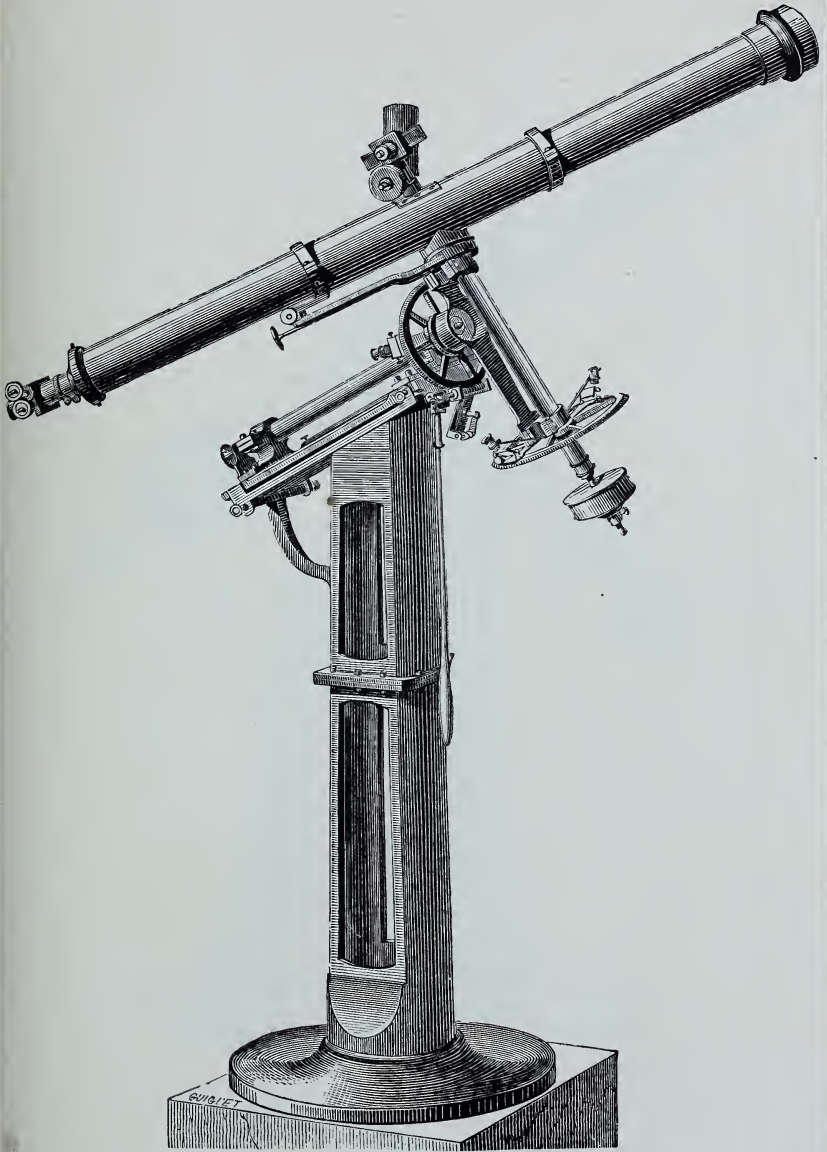

EQUATORIAL OF FRENCH MANUFACTURE.

(By Secrétan).



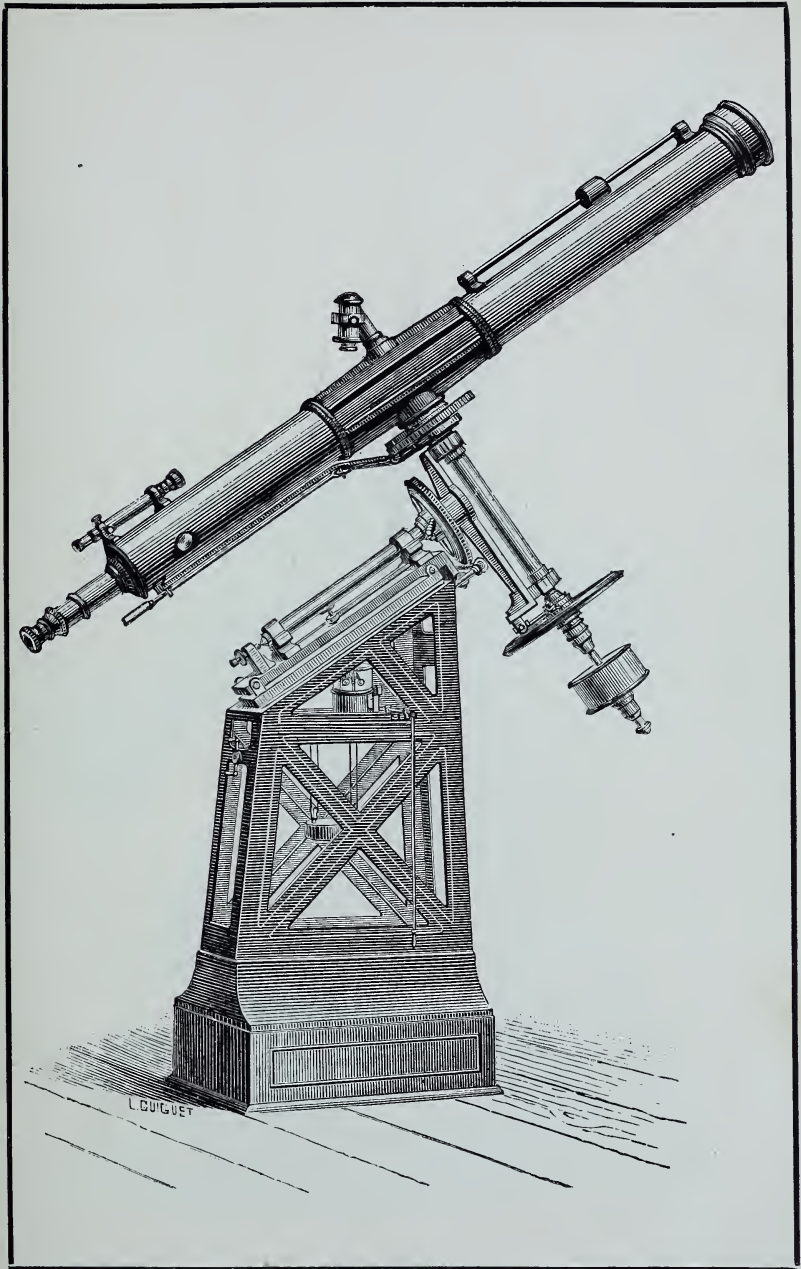

EQUATORIAL OF FRENCH MANUFACTURE.

(By Secrétan.)

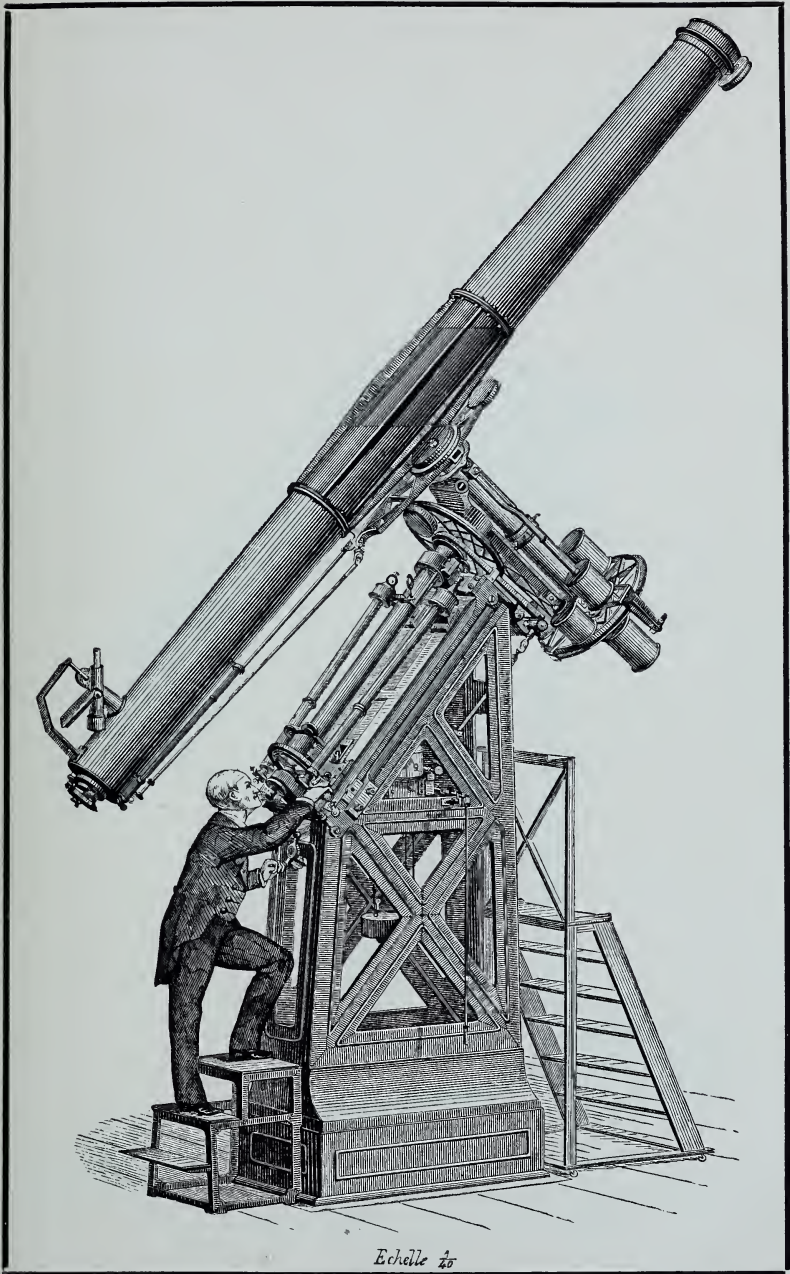

Echelle $\frac{1}{20}$

EQUATORIAL OF FRENCH MANUFACTURE.

(By Secrétan.)

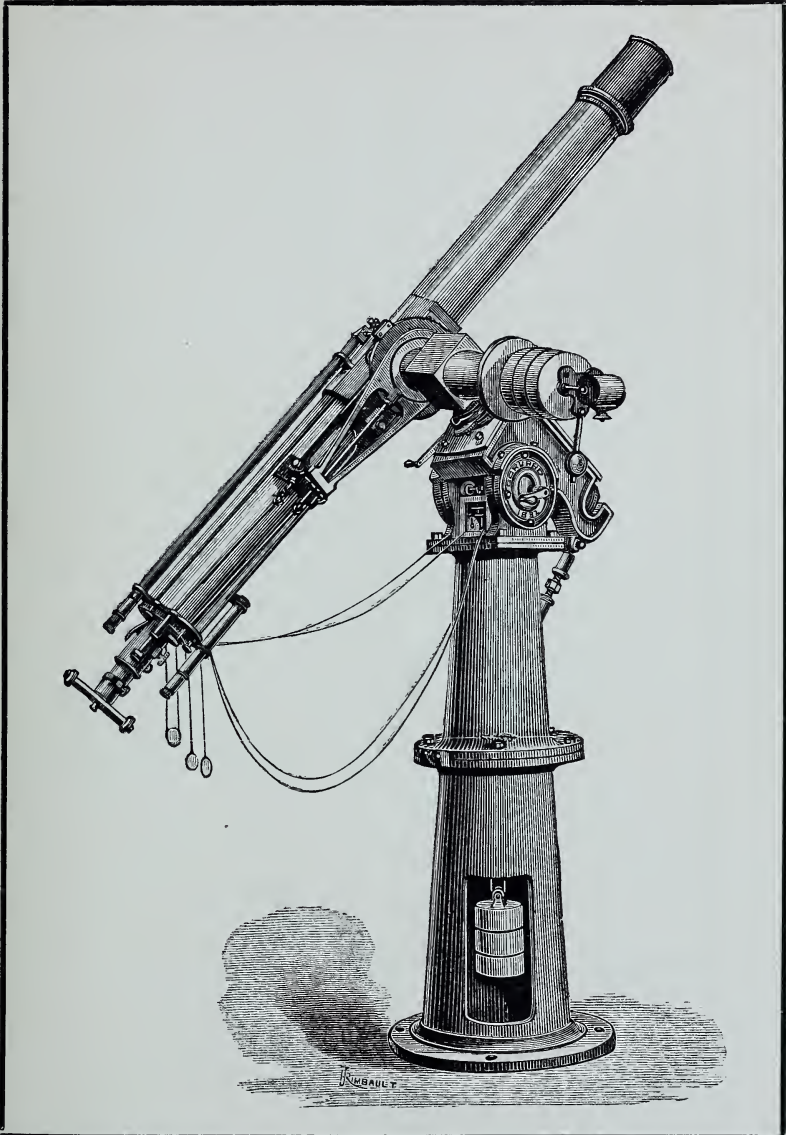

**THE EQUATORIAL OF THE NORTHFIELD GRANGE
OBSERVATORY, EAST-BOURNE.**

(By Grubb.)

Aperture, 6 in. Focal length, 7 ft. 6 in.



- A.A. Lower base casting bolted firmly to stone pier.
 B.B. Second base casting bolted to AA, but capable of azimuthal adjustment on same by screw *b*.
 C.C. Upper base casting bolted to B, but capable of vertical adjustment on same by means of levelling screws inside frame, no^s visible in woodcut.
 P. Polar pillar, inside which revolves the polar axis.
 S. Stay or strut under polar pillar, giving direct support under the principal bearing of polar axis.
 D.D. Cross head, a hollow casting bolted to polar axis, and in which the declination axis revolves. At one end of this cross head is
d.d. the declination circle 18 inches diameter, and divided on gold alloy, and
e.e. the declination clamp, into which gears
f.f. a slow motion screw, worked from eye-end by
g.g. a pair of bevel wheels and handle which give the slow motion in declination.
h.h. is the clamping handle in declination.
i.i. are the cords and lever for right ascension clamping.
k.k. The cords for the slow motion in right ascension.

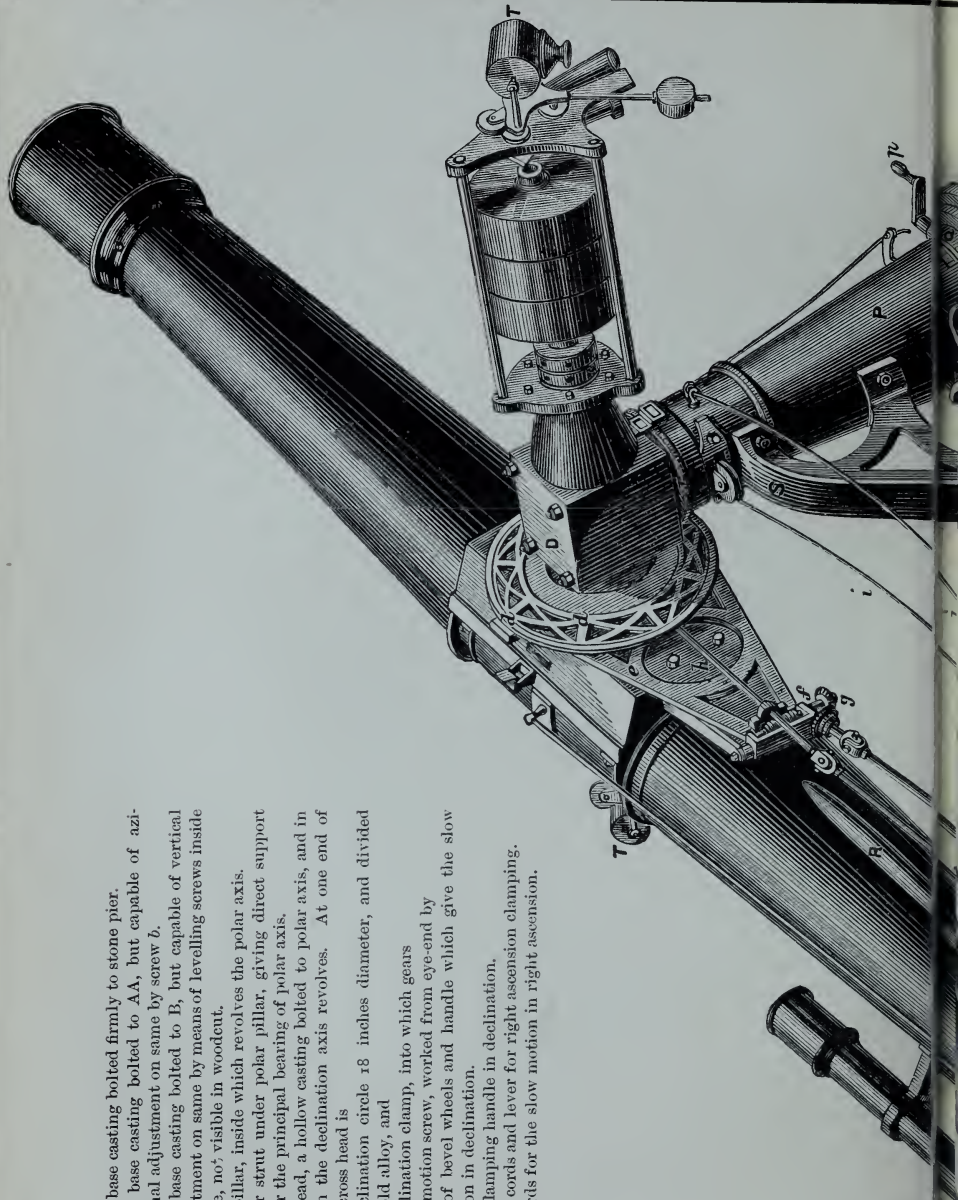

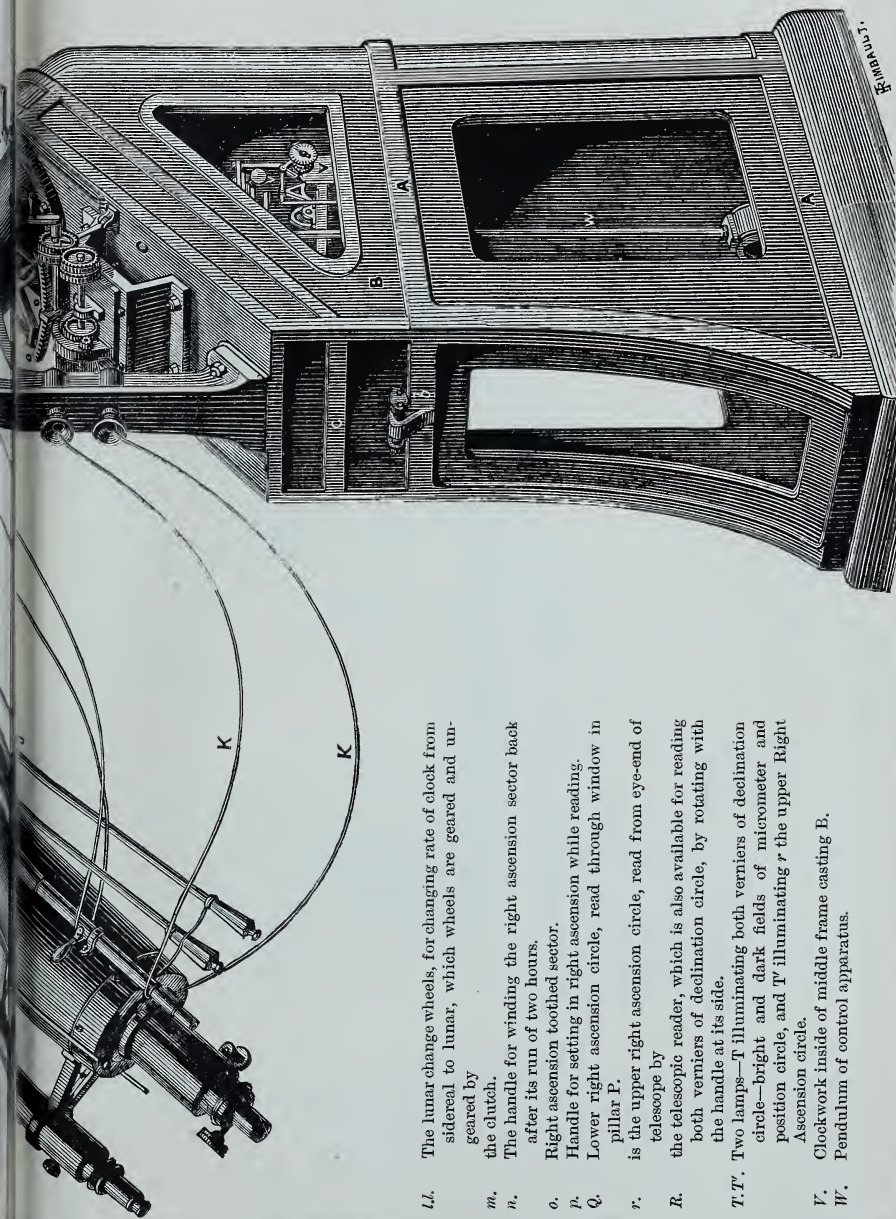

- L. The lunar change wheels, for changing rate of clock from sidereal to lunar, which wheels are geared and un-geared by the clutch.
- m. The handle for winding the right ascension sector back after its run of two hours.
- n. Right ascension toothed sector.
- o. Handle for setting in right ascension while reading.
- p. Lower right ascension circle, read through window in pillar E.
- q. is the upper right ascension circle, read from eye-end of telescope by
- R. the telescopic reader, which is also available for reading both verniers of declination circle, by rotating with the handle at its side.
- T.T. Two lamps—T illuminating both verniers of declination circle—bright and dark fields of micrometer and position circle, and V illuminating r the upper Right Ascension circle.
- V. Clockwork inside of middle frame casting B.
- W. Pendulum of control apparatus.

THE EQUATORIAL OF THE CORK OBSERVATORY. (By Grubb.)

(Aperture 8 in. ; focal length 10 ft.)

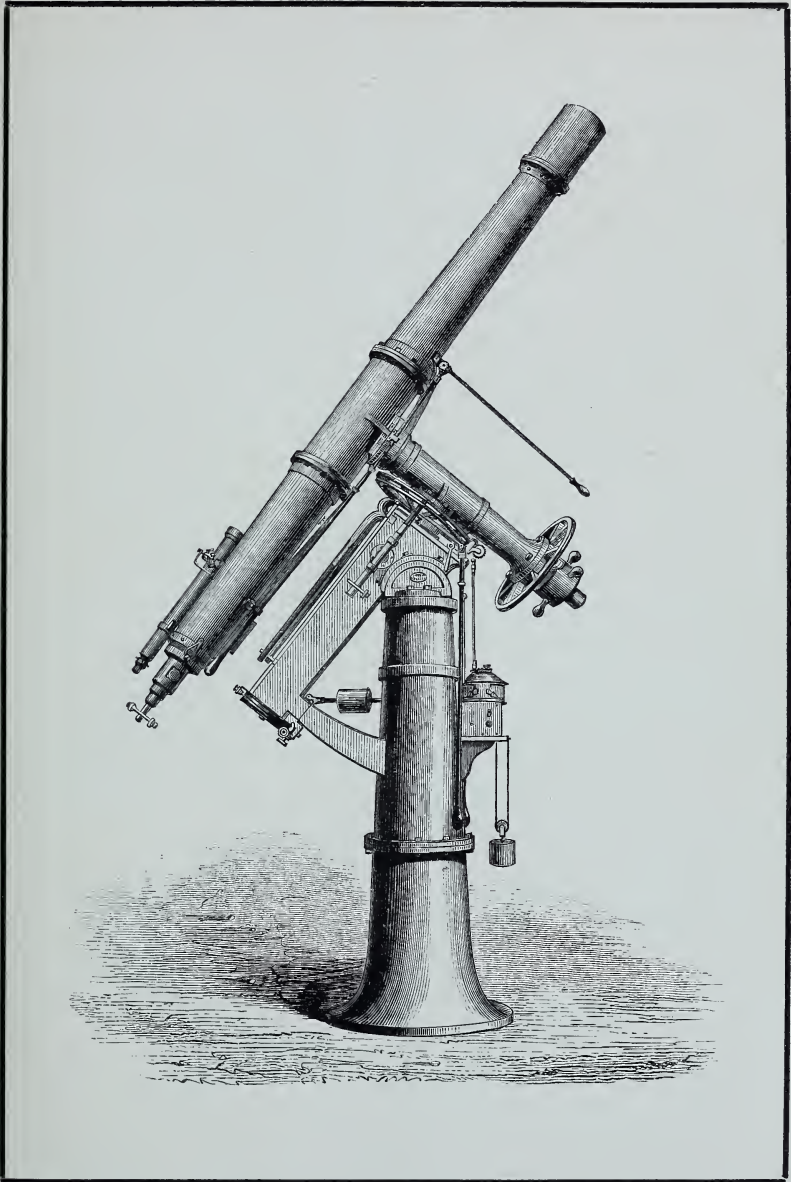

**THE EQUATORIAL OF THE FERNHILL
OBSERVATORY (I.W.).**

(By Cooke.)

Aperture, $8\frac{1}{4}$ in. Focal length, 11 ft. 5 in.





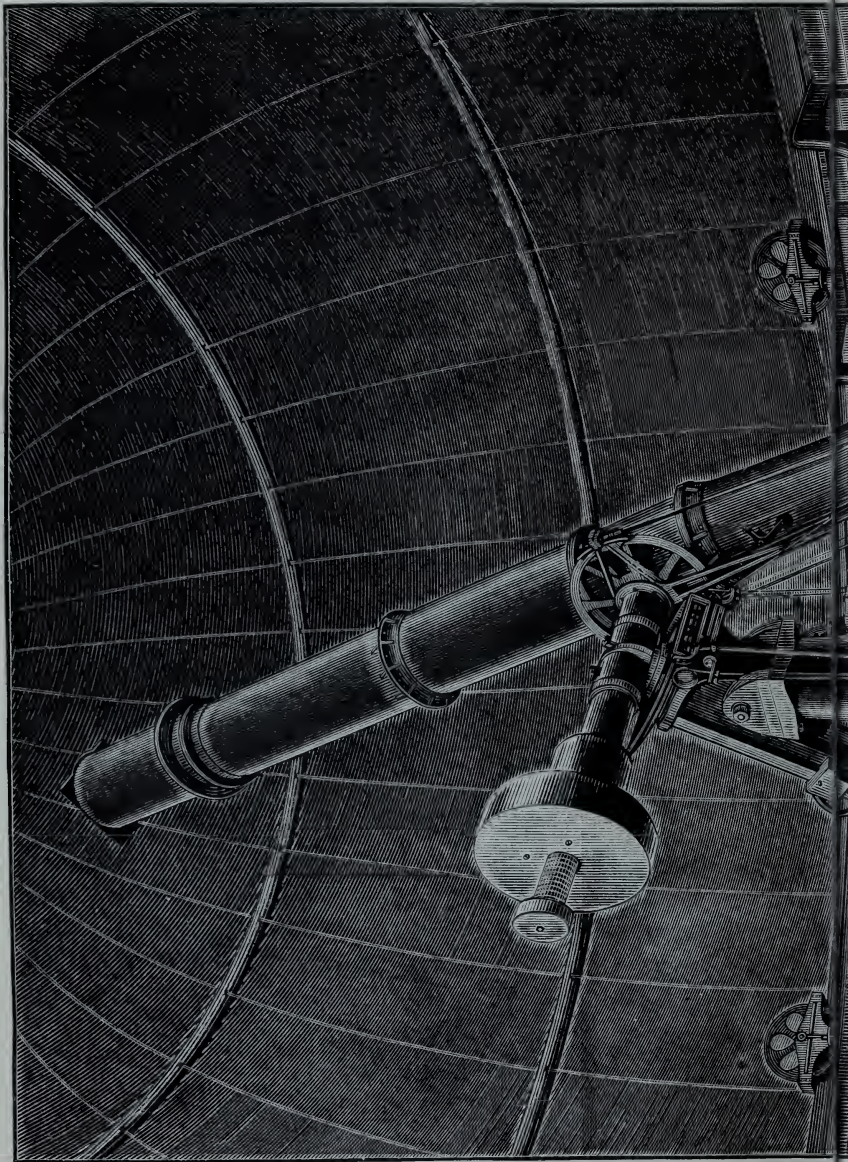
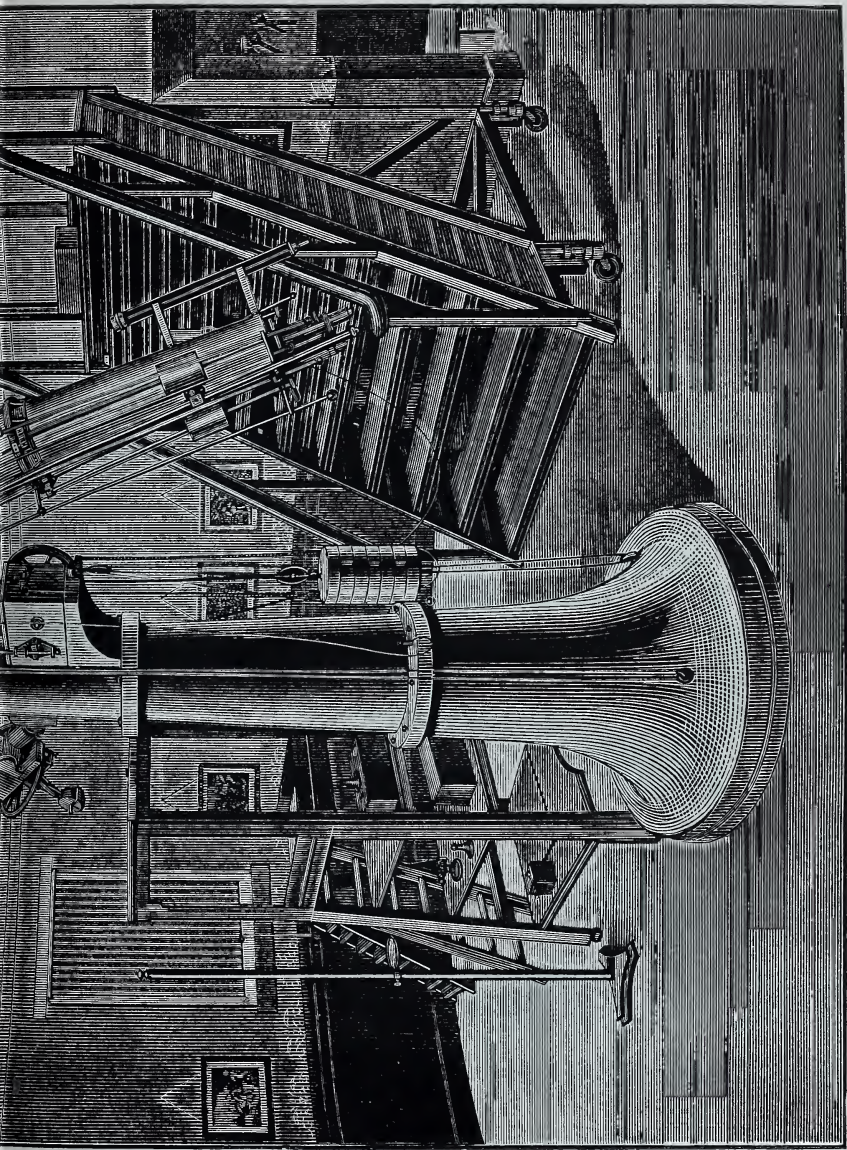
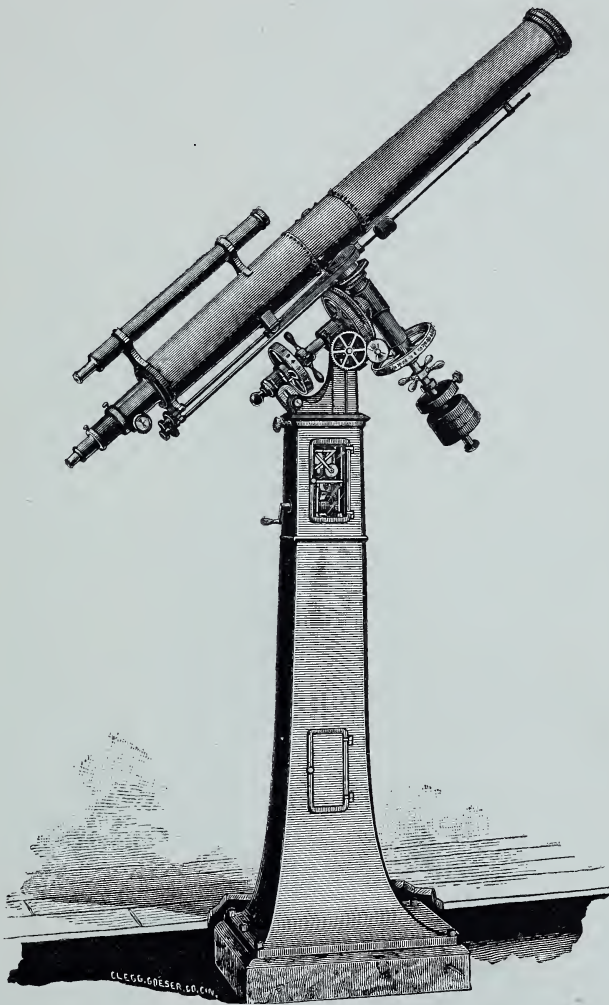

Fig. 65.



15-INCH REFRACTOR OF MR. WIGGLESWORTH'S OBSERVATORY, SCARBOROUGH.

(By Cooke.)



9½-inch EQUATORIAL, OF AMERICAN MAKE.
(By Warner and Swasey.)

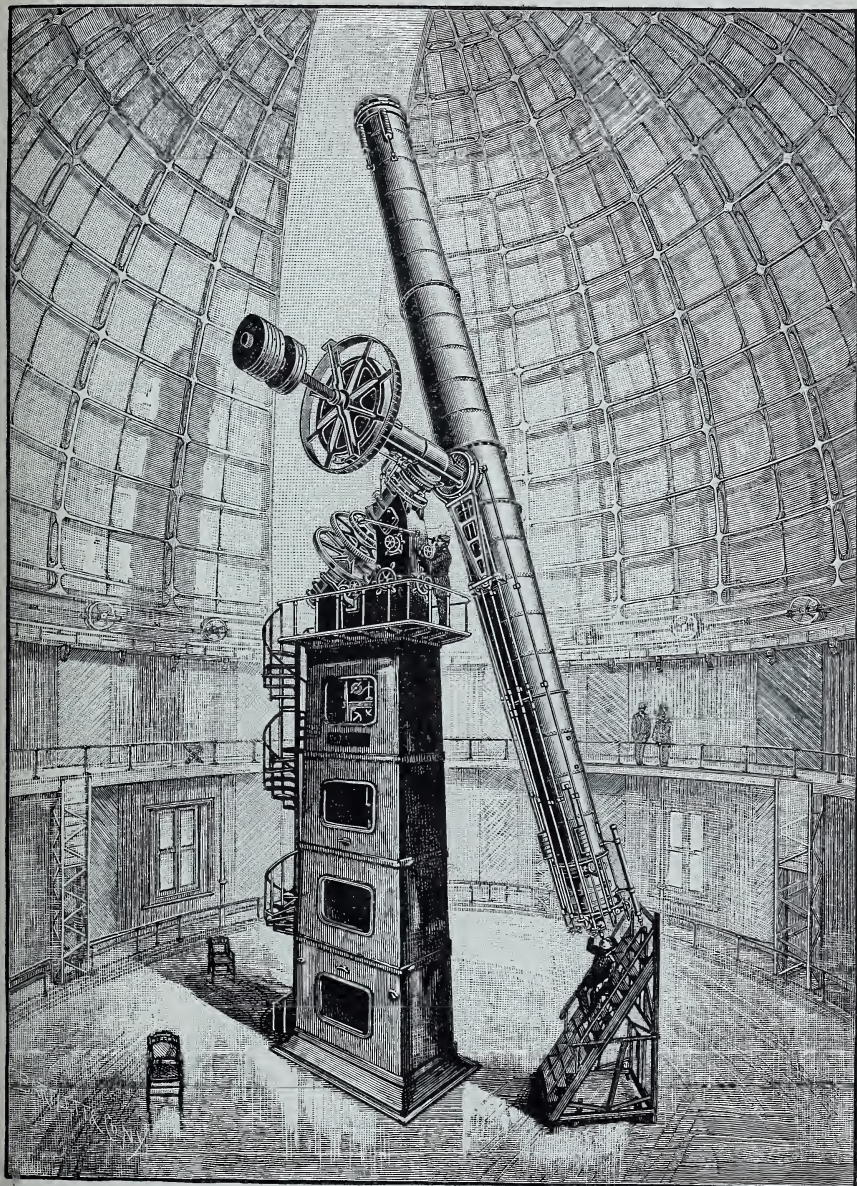

THE GREAT REFRACTOR OF THE LICK OBSERVATORY.

Aperture, 36 in. Focal length, 57 ft.

It not unfrequently happens, especially in connection with expected comets, that the astronomer has occasion to search a portion of the heavens defined in Right Ascension and Declination. The general method of doing this is to subdivide the entire area into a

number of zones,—of a convenient length in Right Ascension and of a width in Declination somewhat less than the field of view of the eye-piece. No special difficulty attaches to the mere shifting from one zone to another in Declination: this may be done almost automatically by rotating some given number of times a tangent-screw applied

to the declination-circle; or the observer, watching some star that happens to be in the field, can turn the tangent-screw until he satisfies himself that the instrument points upon a new zone. To define the limits of the several zones in Right Ascension, however, is not so simple a matter. If it is not important that the limits of the zones be accurately observed, and neighbouring stars are readily visible, perhaps the observer may get along fairly well by simple eye-alignment. Or, if he has an assistant at the Right Ascension-circle, he can be duly apprised of the termination of the zones. Or, each sweep in Right Ascension may be terminated quite at random, the telescope being moved so far each time that the entire zone shall be certainly covered: there must, nevertheless, be frequent reference to the clock and circle. All of these subsidiary operations take a deal more time than is employed at the eye-piece in the actual search. If without leaving the eye-piece, the observer had some convenient

Fig. 68.

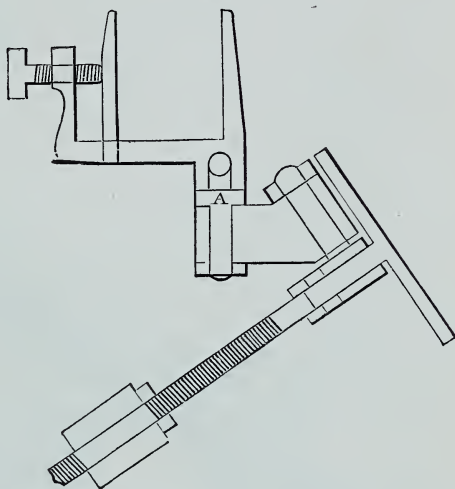
WINDOW EQUATORIAL MOUNTING. (*Erck.*)

way of knowing the moment when his telescope had reached the end of the zone, much of his time would be saved, and the

Fig. 69.

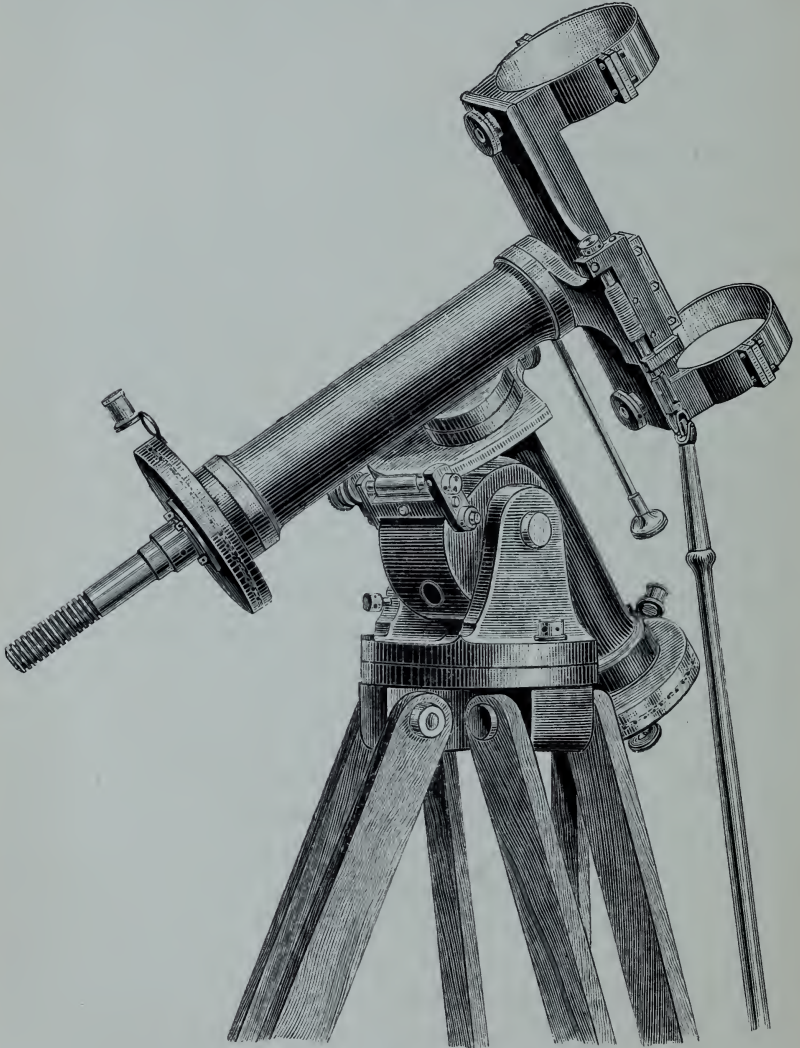

PORTABLE EQUATORIAL MOUNTING ON TRIPOD.

search could be prosecuted with greater rapidity. Mr. D. P. Todd, of the *American Nautical Almanac* Office, devised for this purpose in 1877 the instrument about to be described.

“In sweeping over the zones in Right Ascension, the clock-motion and sector are, of course, detached from the polar axis. The arc of the sector is to be graduated, as the Right Ascension circle is graduated; it need be only a continuous graduation of hours and parts thereof. Sliding upon this graduation, or adjacent to it, are two metallic vernier-like pieces, both of which are furnished with screws for clamping to any part of the graduated sector-arc. Each of these verniers carries a projecting metallic point, attached to it on a line joining the centre of the polar axis and the zero point of the vernier. Revolving freely about the polar axis, and adjacent to the sector, is a collar, carrying a projecting arm the end of which will just touch the metallic points attached to the verniers. This collar has a screw for clamping it to the polar axis, just as the sector has. And, moreover, electric apparatus is so disposed that, whenever the end of the projecting arm comes in contact with either of the metallic points attached to the verniers, a telegraphic sounder shall beat, or an electric bell shall ring. The apparatus is now complete. Its use is as follows:—By means of the graduation on the sector, the two verniers contiguous to it are set at a distance apart equal to the length of the zones to be searched. The sector is then unclamped from the polar axis and connected with the clock, and the clock set a-going. The telescope is then set to the Right Ascension of one end of the zones to be searched, and the projecting arm is at the same time brought into contact with the metallic point of the corresponding vernier, and clamped to the polar axis in that position. After the declination-circle is set, the whole instrument is ready for the search, and it is not necessary to remove the eye from the telescope, as the click of the sounder or the ring of the bell apprises the ear of the observer whenever the telescope reaches either limit of the zone in Right Ascension.”

Mr. Todd thinks that this apparatus will be found especially useful in searching for intra-mercurial planets during total solar eclipses (when the available time is critically short and the area to be swept over is extensive), and in orbit-sweeping generally. If the orbit is somewhat inclined to the equator, it will be found convenient to stop the equatorial clock for a few seconds after a given space in Declination has been passed over. A new system of zones may then be begun.

Mention may here be made of a little instrument which, though a German equatorial in its essential features, has points of its own calculated to render it of use to many amateurs, namely Horne and Thornthwaite's *Star-Finder*.

The particular idea aimed at in its conception was to furnish the means of either ascertaining the position of any important celestial object, preparatory, it might be, to an examination of it with an efficient but non-equatorially-mounted telescope, or to determine the identity of any object already observed.

The instrument consists of a telescope *a*, having at *b* a sliding

adjustment and at *c* an eye-piece furnished with cross wires. The tube occupies the diameter of a divided circle *d* (which is the

Fig. 70.

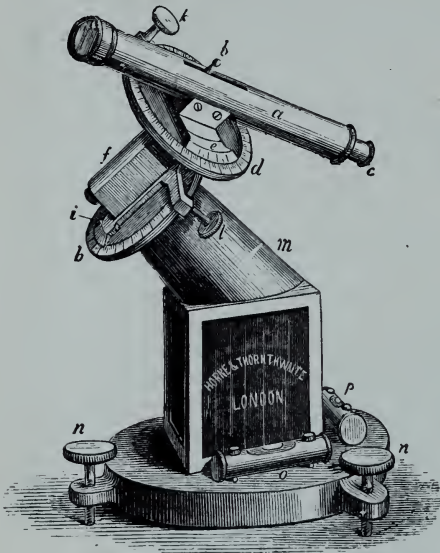

THE STAR-FINDER.

declination circle), the graduations of which proceed from 0° at the head and foot of the circle both ways to 90° at the sides, and which are read off by a vernier index *e* carved upon the flank, as it were, of the telescope *a*. The scales are appropriately lettered N and S respectively upon the left and right halves of the circle. Passing through the centre of the declination circle is the arm *f*, which admits the revolution of the tube, and itself occupies a diameter of the hour-circle *h*. This circle, graduated into 24 hours, and degrees of 4 minutes (of time) each, from zero on the right, is read, by the vernier index *i*, at the extremity of the arm of declination *f*. Clamping-screws, *k* and *l*, secure the telescope and arm of declination to their respective circles. The latter arm, attached at right-angles to a carefully-fitted polar axis, is capable of taking up any position upon the hour-circle *h*, which is equally fitted at right-angles to the polar support *m*. It is necessary that this support be accurately adapted (by an easy adjustment provided by the maker) to the latitude of the place where the star-finder is intended to be employed. It is fixed to a massive iron foot, which must be placed perfectly level by the three foot-screws *n n n*, aided by observations of the levels *o* and *p*.

To level the bed of the instrument, adjust the milled heads *n n n* until the bubbles of air in the spirit-levels *o* and *p* are exactly in the middles of the tubes, the hour-circle of the instrument facing

the declination circle), the graduations of which proceed from 0° at the head and foot of the circle both ways to 90° at the sides, and which are read off by a vernier index *e* carved upon the flank, as it were, of the telescope *a*. The scales are appropriately lettered N and S respectively upon the left and right halves of the circle. Passing through the centre of the declination circle is the arm *f*, which admits the revolution of

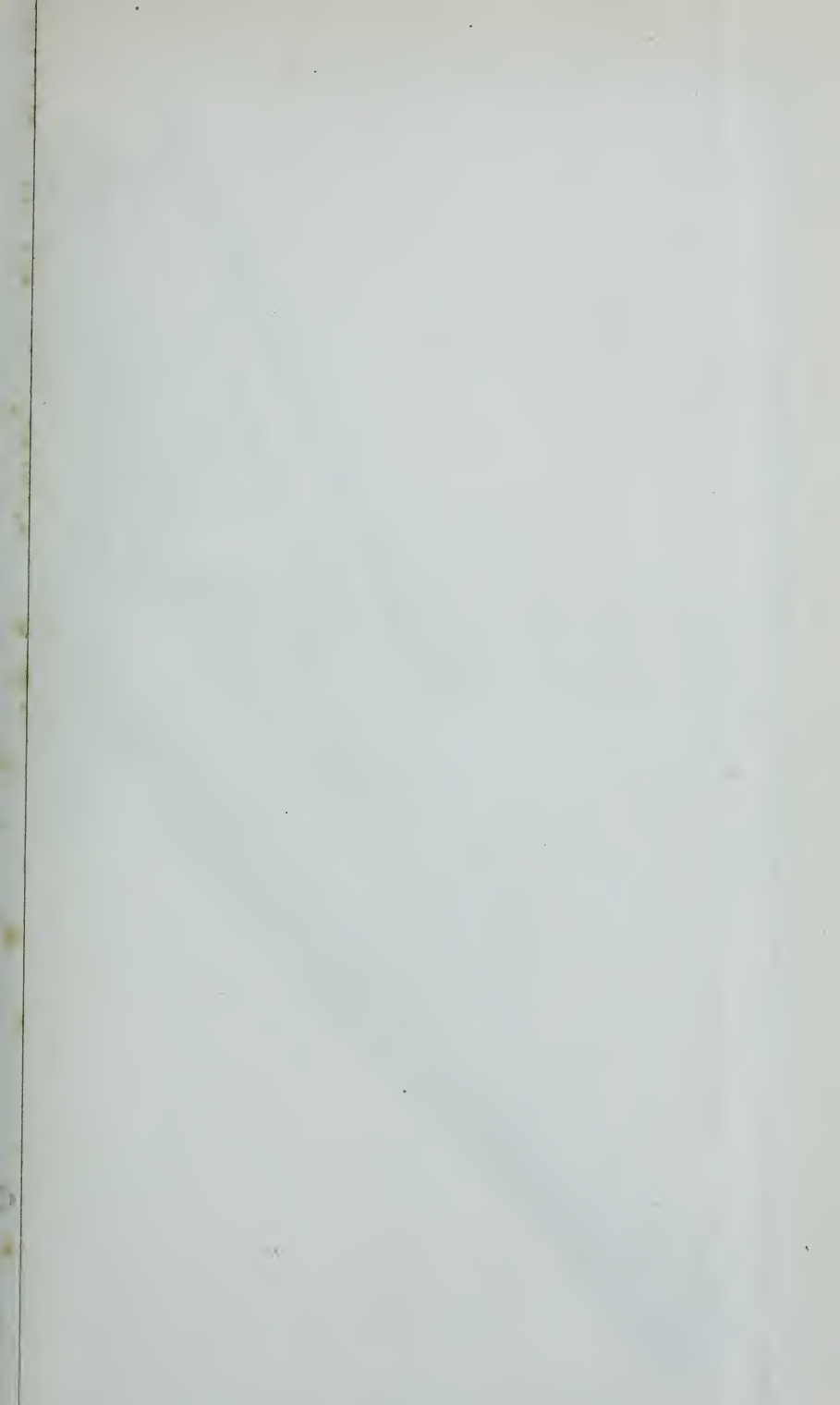
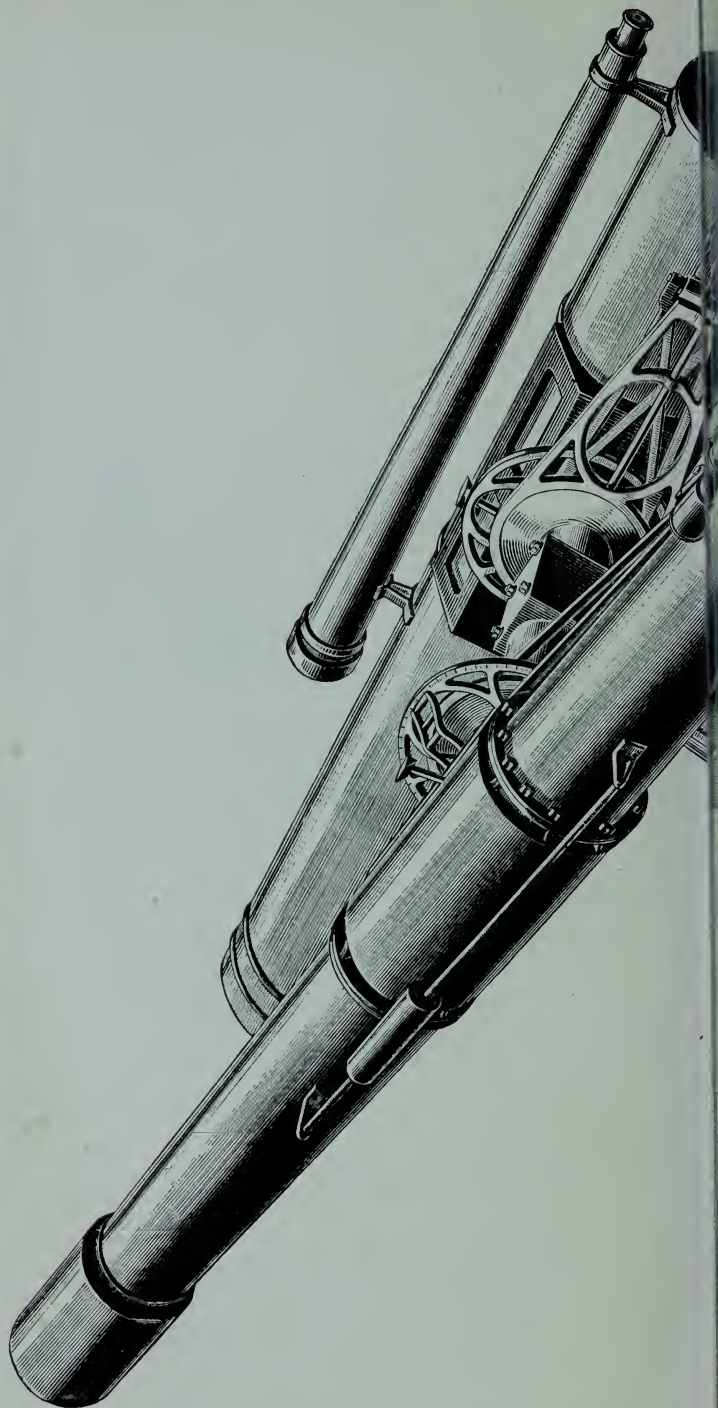
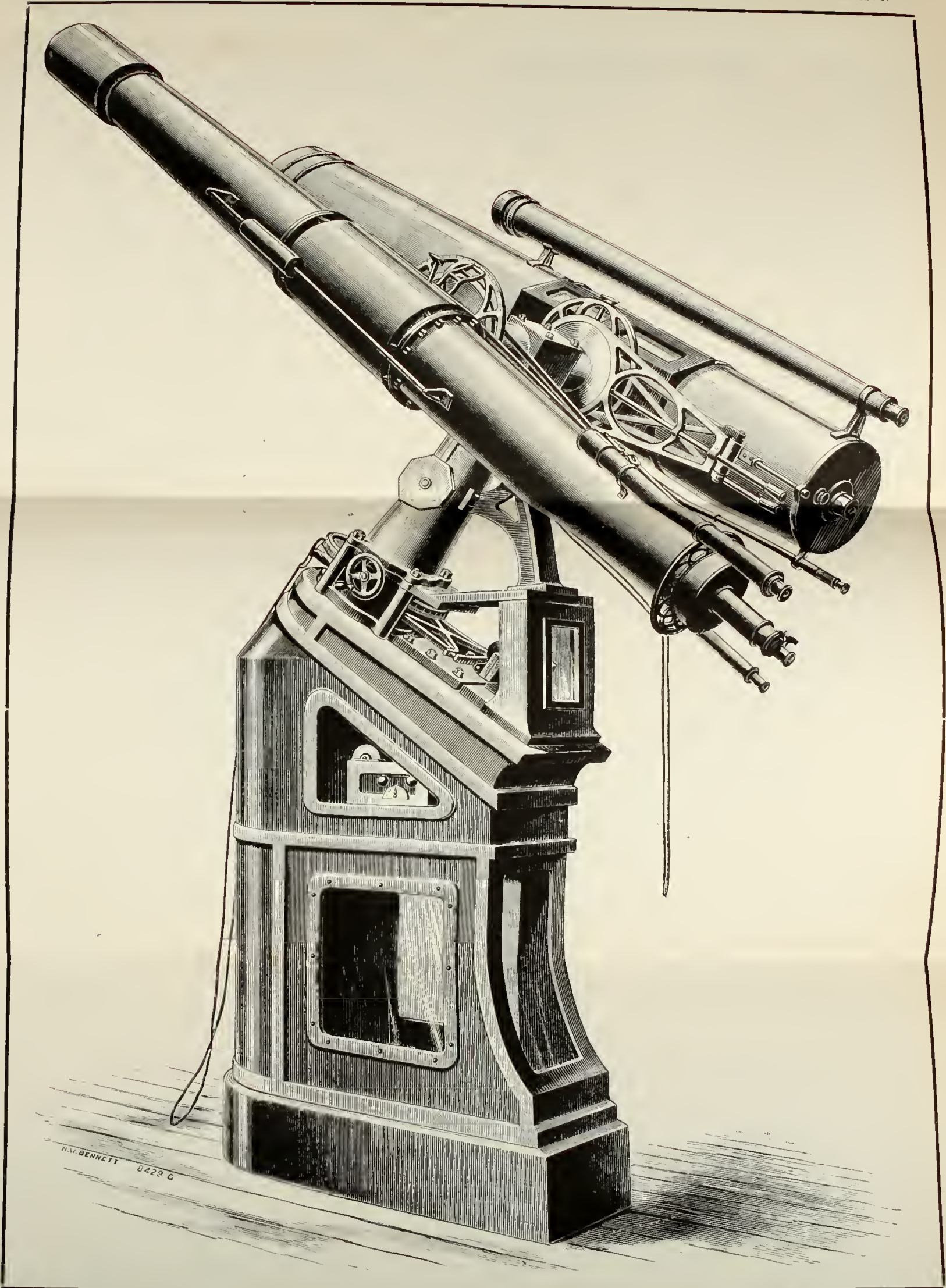

Fig. 71.





THE TWIN EQUATORIAL.

Fig. 71.



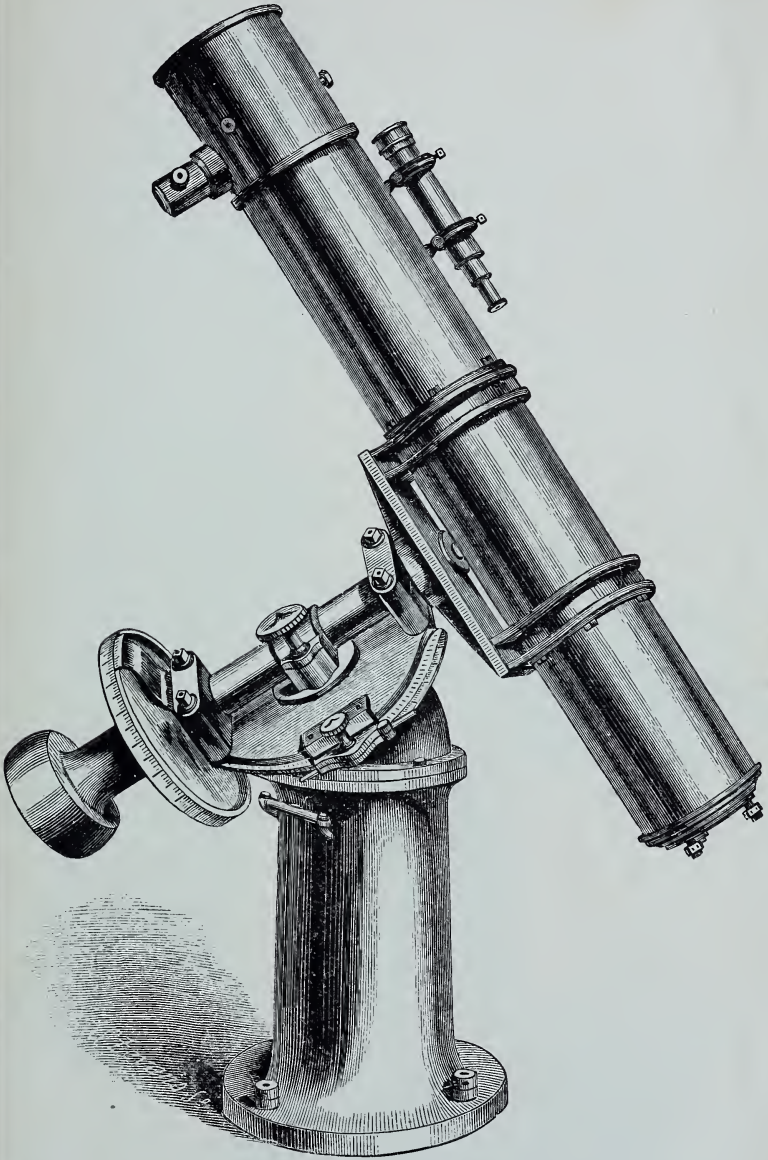

EQUATORIALLY-MOUNTED REFLECTOR.

Aperture, $6\frac{1}{2}$ in.

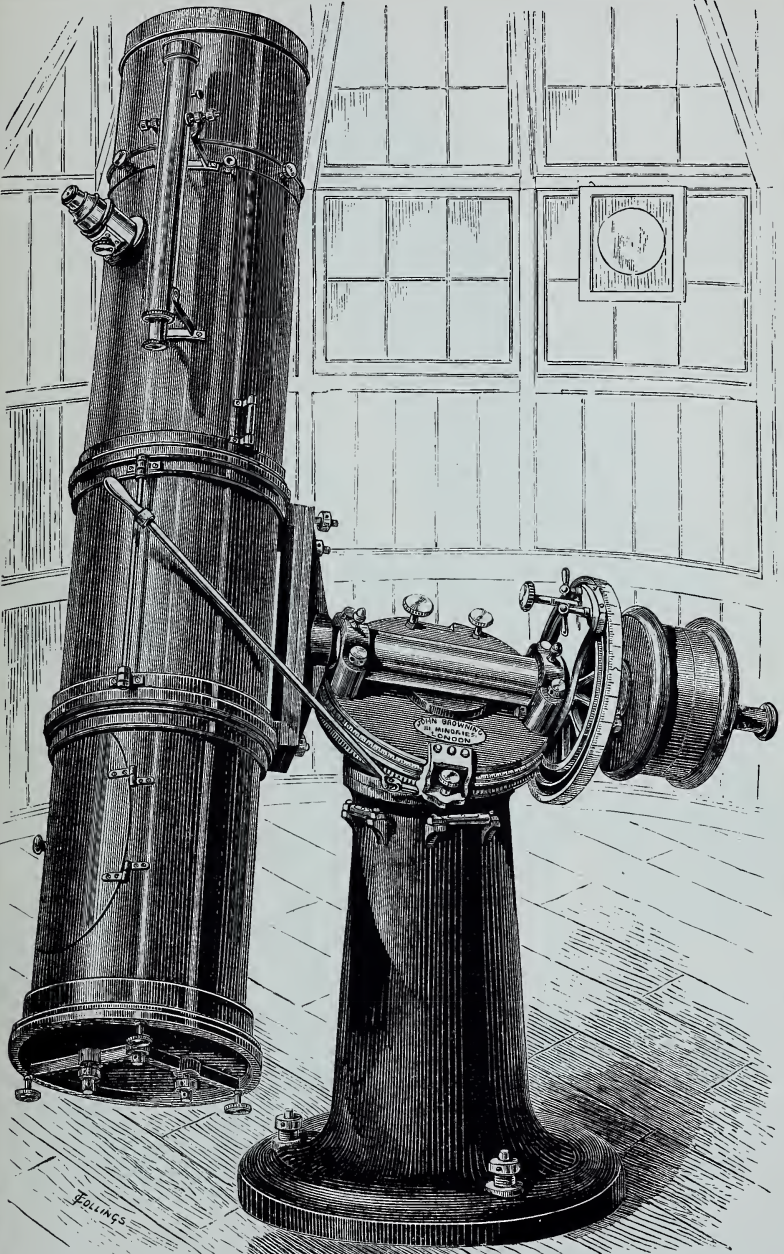

EQUATORIALLY-MOUNTED REFLECTOR.

Aperture, $10\frac{1}{4}$ in.

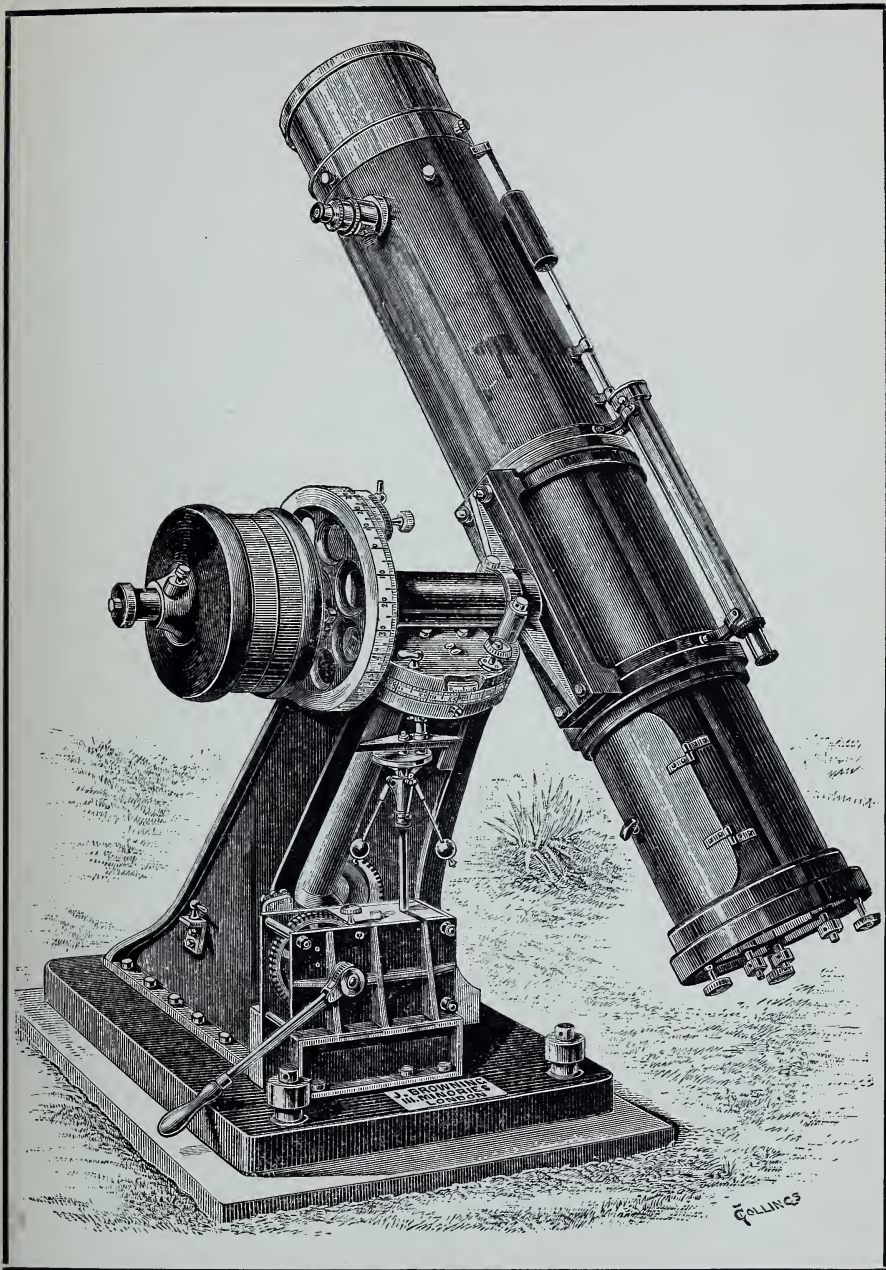

EQUATORIALLY-MOUNTED REFLECTOR AT THE
ROYAL OBSERVATORY, EDINBURGH.

Aperture, $12\frac{1}{4}$ in.

to the north. Now reverse the instrument, that the hour-circle $\frac{1}{2}$ may face the south. If the bubbles of air in both levels still remain central, the bed or support is truly level. But if the bubbles be not so, the support must be lowered at the sides where the bubbles appear. The bubbles should be only *half* corrected by this depression of the support, the remaining half of the apparent error being due to the foot-screws, which were adjusted at the first observation to meet the errors of the support. A few trials will fix the support quite horizontal; and if it be a stone pier or pillar, the slab which forms its surface may be cemented in this position. The general adjustments are the same as those of the equatorial.

The Twin Equatorial comprises 2 telescopes of different sizes and different forms mounted so that their work can be compared. The Twin Equatorial engraved in Fig. 71, Plate XVI. was made by Sir H. Grubb for Dr. Huggins.

In applying to a reflector an equatorial mounting, though of course the principle remains the same yet the greater dimensions, weight, and, I will add, awkwardness of reflectors (that is to say Newtonians, which are those most in use) necessitate the adoption of various practical expedients which will appear strange to persons accustomed only to refractors.

Plates XVII., XVIII. and XIX. represent various equatorial mountings for reflectors. The last of these is a large and fine instrument formerly the property of the Earl of Crawford and erected at his Observatory at Dun Echt, Aberdeenshire, but presented by him in 1888 to the Royal Observatory, Edinburgh. The general construction of each of these instruments will be sufficiently understood from the engravings, but in the case of the two larger instruments the tubes are so arranged that they will revolve bodily, and thus the respective eye-pieces can be brought at pleasure to the position which will best relieve the observer from straining either his body or his eyes.

Lord Crawford's equatorial is fitted with clockwork of special construction. The clock is placed on the North side of the instrument so that it shall be as much as possible out of the way

and protected from injury. Means are provided to enable an observer using the finder to bring an object into the centre of the field of the large mirror.

Fig. 75 represents a form of Universal Equatorial, for a reflector, originally devised by Sir G. B. Airy but perfected as regards mechanical details by Browning. The whole telescope together with the polar axis is carried by centres at E; large plates are attached to the sides of a cradle which carries the polar axis; A is the said axis; B B the cradle; C C an arc provided with a

Fig. 75.

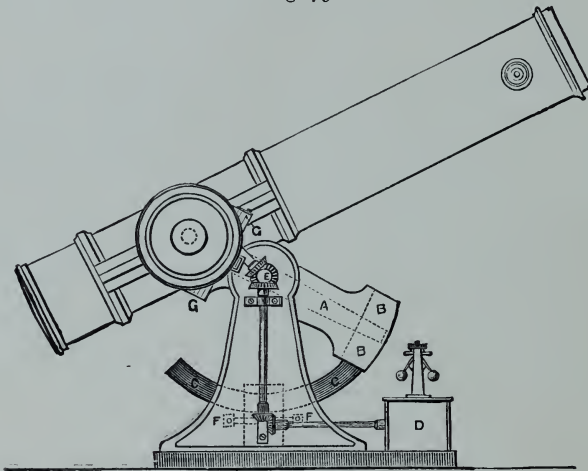

UNIVERSAL EQUATORIAL FOR A REFLECTOR.

clamping arrangement of which the adjusting screws are shown at F F; a clamp screw is provided, but in any drawing this will be hidden by the spur-wheels. When this screw is eased the angle of the polar axis may be changed at pleasure and the axis moved from a horizontal to a nearly vertical position, or it may be brought to any intermediate position and there clamped and finally adjusted by the capstan-headed screws F F. D is a clock which by means of a bevelled spur-wheel gives motion to a wheel which revolves round the centre on which the polar axis turns at E. This wheel imparts motion to 2 other wheels and through them turns the driving screw on the hour-circle G G and so drives the instrument. As the wheel E runs loose on the

spindle, and the distance between the wheel driven by E and the driving screw on the hour-circle remains unaltered, it is

Fig. 76.

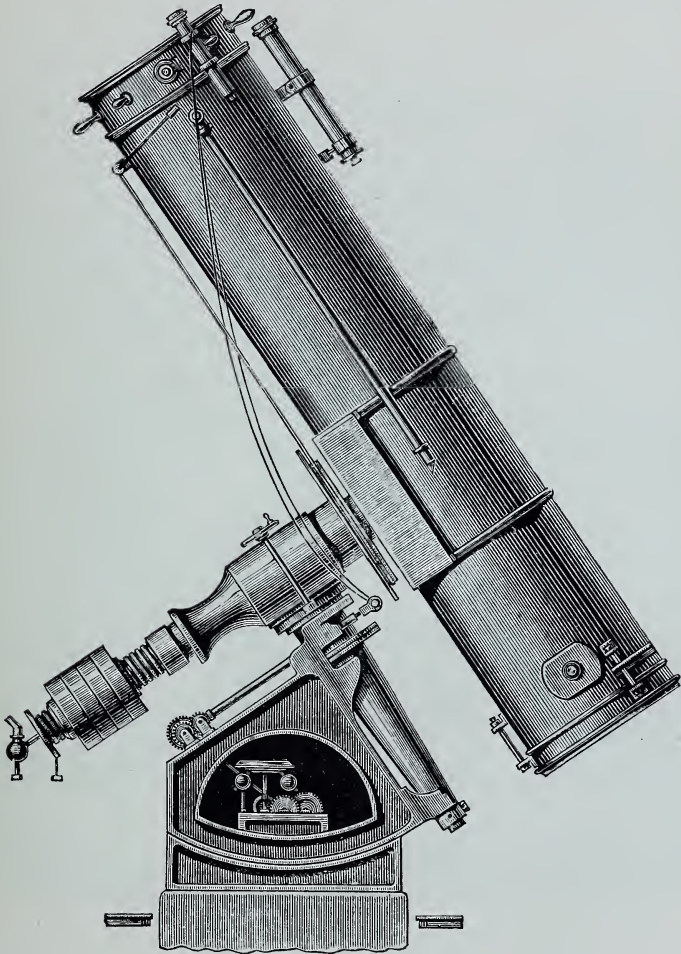

EQUATORIAL REFLECTOR AT DR. VON KONKOLY'S OBSERVATORY, O'GYALLA, HUNGARY.
(By Grubb.)

evident that a change in the inclination of the polar axis does not interfere with the motion communicated to the hour-circle by the clock °.

° *Month. Not.*, vol. xxxii. p. 41. Dec. 1871. Lord Rosse's 3-ft. Reflector had an equatorial mounting applied to it in

1876, for a description of which see *Phil. Trans.*, vol. clxxi., 1881.

Fig. 76 is a form of equatorial mounting by Grubb which is capable of affording to a Newtonian reflector circumpolar motion up to the pole.

Fig. 77.

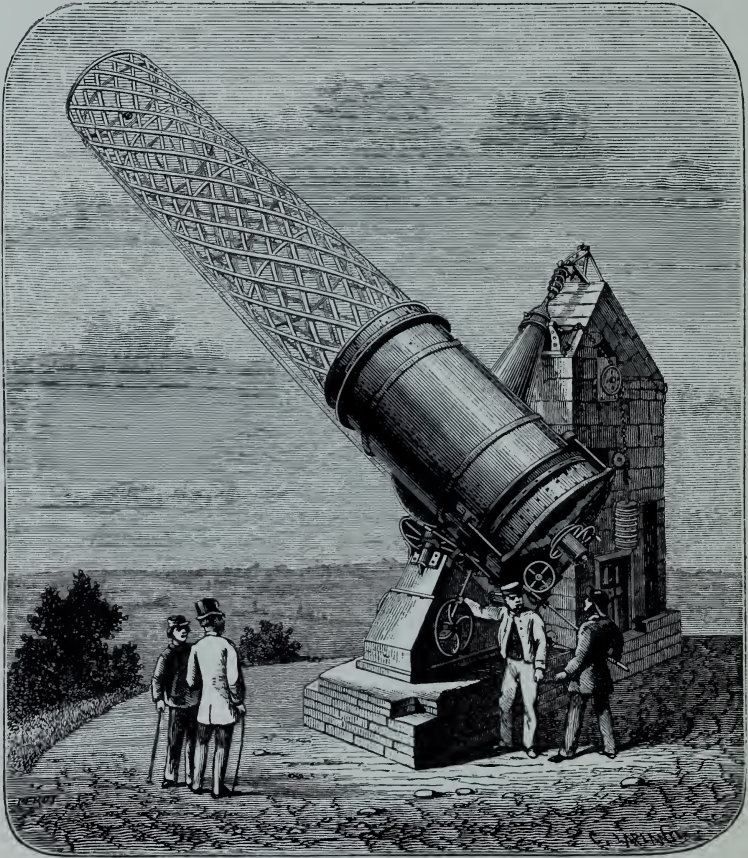

THE GREAT REFLECTOR OF THE MELBOURNE OBSERVATORY.

Aperture, 4 ft.

Mr. E. H. Liveing has devised a Portable star-finder for attachment to telescopes which only possess motion in altitude and azimuth. In a full description of this instrument reference must be made to the inventor's own account ^f.

^f *Month. Not.*, vol. xxxix. p. 91. Dec. 1878.

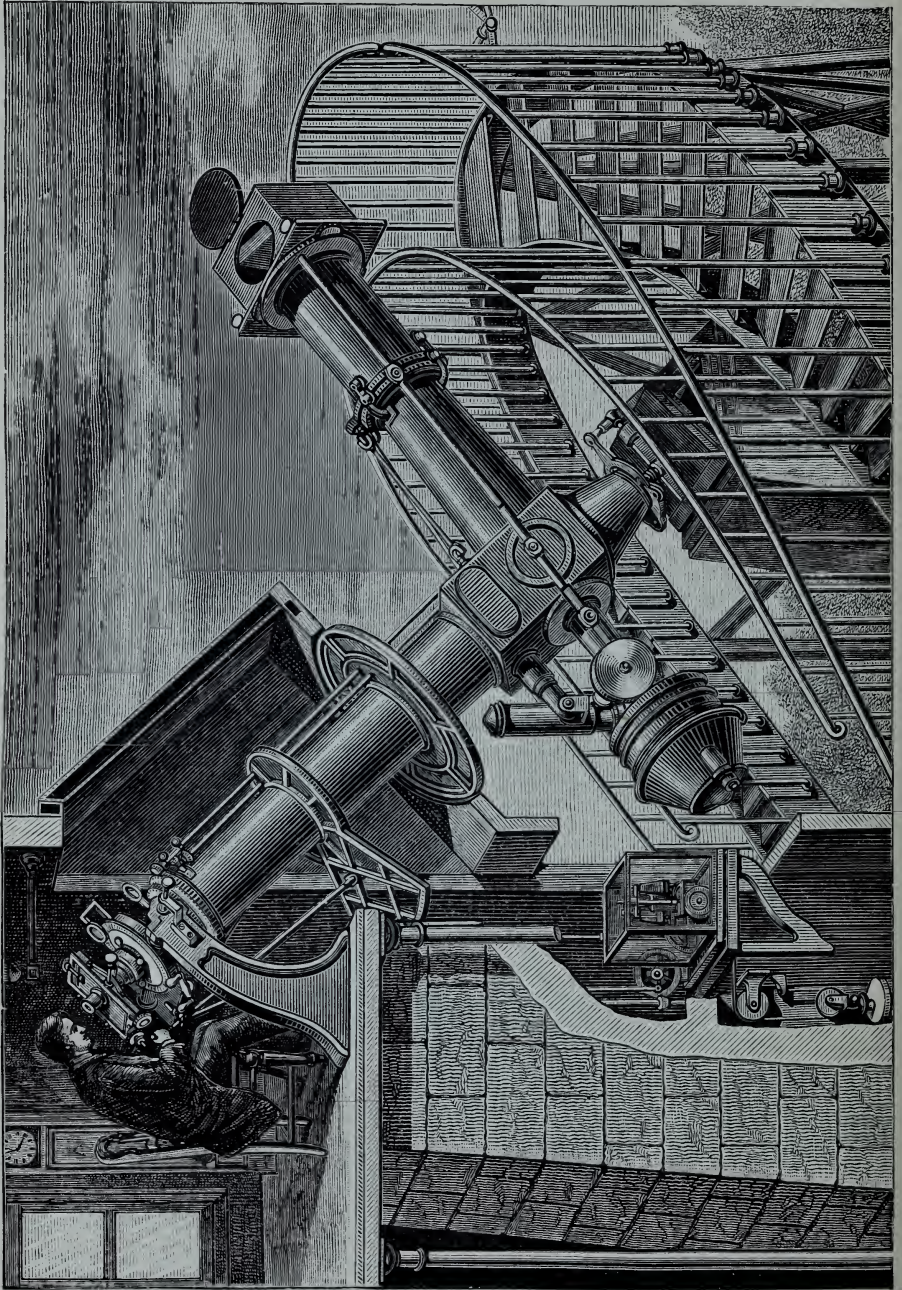

Fig. 78, Plate XX. represents a form of equatorial invented by M. Löwy, the Sub-Director of the Observatory at Paris. It is intended to obviate the great personal inconvenience which the users of large telescopes have to undergo in having to travel backwards and forwards and up and down through considerable distances in order to follow the movements of their instruments. The original French name of the invention is the "*Equatorial Coudé*," which may be freely translated as the "elbow equatorial." It will be seen from the engraving that whatever may be the direction in which the telescope is pointed and however much it may be moved, the eye-piece, and by consequence the observer, remains virtually stationary in one place. The ordinary dome employed to cover the ordinary equatorial, which has to be turned round or have its shutters altered every time the telescope is required to point in a new direction, is dispensed with; and in lieu thereof the instrument is housed under a moveable shed which only has to be pushed away when work begins for the evening and be pushed home again when work is over.

The optical principle of the instrument consists simply in the light of the star to be observed being twice reflected by plane mirrors, so that the image is sent into a fixed eye-piece with the result that the observer without changing his own position can point the instrument to any required part of the heavens by merely shifting the mirrors and a part of the apparatus, he himself remaining stationary.

It will be seen that the telescope tube which carries the object-glass is bent at a right angle. At the angle or elbow a plane mirror is fixed inclined at an angle of 45° to the tube, so that the rays of light coming from the object after having passed through the object-glass and having traversed the main tube are reflected by the mirror and so reach the eye-piece situated at the extremity of the subsidiary tube. This is fixed and may be regarded as the equivalent of the ordinary Polar axis in so far that it is adjusted to point to the Pole. Its upper extremity, where the eye-piece is mounted, reaches into the apartment of the observer, who, quietly and comfortably seated, observes by

looking down a tube, which at Paris is inclined at an angle of about 49° to his floor. Such an angle as this evidently offers the maximum of convenience with the minimum of fatigue, and is the angle ordinarily preferred by microscopists. The exterior part of the telescope, which is the main tube which carries the object-glass, can turn, taking with it the mirror at the elbow, around the fixed tube; that is to say around the Polar axis to which it is perpendicular. Hence it results that by this movement of rotation the extremity of the optical axis can travel right through the celestial equator. If this were all that could be accomplished the observer could only scrutinise objects situated actually at the equator. In order to complete the instrument as an equatorial available for any parallel of Declination there is placed in front of the object-glass a second mirror inclined at an angle of 45° , which brings into the telescope rays of light perpendicular to the direction of the tube which carries the object-glass. As however this mirror is mounted in a cylindrical socket which can turn upon itself at the pleasure of the observer, it can occupy all positions always making an angle of 45° with the axis of the main tube; and so the observer can bring to his object-glass all the rays of light falling on a plane perpendicular to the axis of the main tube. That is to say, he can by simply shifting the mirror reach with the telescope all parts of the hour-circle perpendicular to the axis of the main tube; in other words, any desired angle of Declination from the equator.

The displacement of the front mirror corresponds therefore with the rotation of an ordinary equatorial on its Declination axis, and the position of this mirror will indicate approximately the Declination of the star observed. The rotation of all the front part of the instrument around the polar axis enables the observer to note at all hour-angles the position of the moveable tube referred to a divided circle attached to it and so indicates the R.A. of the object observed. If the front mirror is clamped and the instrument is turned on its polar axis, it will sweep over all points of the heavens which have the same Declination.

The instrument is provided with all the usual clamps, slow motions, and clock-work commonly applied to ordinary equatorials, from which it does not differ otherwise than has been explained above. The clock-work however only imparts motion to the main tube which carries the object-glass by making it turn round the polar axis in a direction *contrary* to the diurnal movement^g.

The adjustments which the equatorial requires are 6 in number. For correct observation it is necessary:—

1. *That the polar axis be placed at the altitude of the Pole.*
2. *That the index of the declination circle point to 0° when the optical axis of the telescope points to the equator.*
3. *That the polar axis be placed in the meridian.*
4. *That the optical axis or line of collimation of the telescope be at right angles to the declination axis.*
5. *That the polar and declination axes be at right-angles to each other.*
6. *That the index of the hour-circle point to 0^h when the telescope is placed in the meridian; i.e. when the declination axis is horizontal.*

1st adjustment.—*To bring the polar axis to the altitude of the Pole.*

Put on a transit eye-piece, or preferably a parallel-wire micrometer, and place the horizontal wire of the former or one of the moveable webs of the latter as horizontal and as near the middle of the field of view as possible. Now adjust the wire so that an equatorial star near the meridian runs along it; and, having done so, move the transit wires (or the micrometer) through 180° . If the star is no longer threaded on the web, move the latter half way towards the star, and again bring the star on to the web by the declination screw. Once more rotate the eye-piece (or micrometer) through 180° , and the star should continue to travel along the central wire, which will now be in the middle of the field of view. This result secured, we select from the *Nautical Almanac*, or some star catalogue, a star whose position is very accurately known, and which at the time in question happens to be on or very near the meridian. Bring the

^g Abridged from an article by M. G^{ér}igny in *L'Astronomie*, vol. iii. p. 220. June 1884. Having seen this instrument

at Paris in September 1889, I cannot refrain from expressing my high appreciation of its usefulness.

horizontal wire on to it, and read the declination circle; turn the polar axis half-round and again read the circle; the mean of the two readings is the instrumental declination of the object; correct for refraction, and compare the corrected value with the true Declination given in the catalogue. If the selected star be above the Pole and near the zenith, (which it is best that it should be, as chances of error from refraction are thereby reduced to a minimum,) and the instrumental exceeds the true Declination, the pole of the instrument is above the pole of the heavens, and *vice versâ*. The polar axis must then be adjusted as needs be, by the screws provided for the purpose.

Example. When ϵ Ursæ Minoris was near the meridian, its declination was observed to be $82^{\circ} 15' 20''$ when the face of the circle was E., and $82^{\circ} 15' 53''$ when the face was W.

The mean of these two observations is $82^{\circ} 15' 36.5''$; the refraction was $52.8''$; so that the corrected declination was $82^{\circ} 16' 29.3''$. The true declination by the Almanac was $82^{\circ} 17' 19.3''$. Hence the polar axis was too low by $50''$.

2nd adjustment.—*To make the index of the declination-circle point to 0° when the optical axis of the telescope points to the equator.*

Take half the difference of the 2 readings obtained as above: this will be the index-error of the declination-circle verniers, and they must be shifted accordingly by the proper screws. Several pairs of observations should be made, and a mean of them taken to secure an accurate result.

Example. According to the above observation the index-error was $16.5''$ —additive to readings with the circle E., and subtractive from readings with the circle W.

When the error is small in amount it is often preferable not to attempt to correct it by the screws, but to note the value thereof as a *constant of correction*, to be applied with the proper sign to every observation made.

3rd adjustment.—*To place the polar axis in the meridian.*

Direct the telescope to some known star about 6 hours or so from the meridian on either side, but removed as far as possible from the Pole and the horizon. Read the declination circle:

correct for refraction^h, and compare the result with the value assigned in a good catalogue. If the star is E. of the meridian, and its observed declination exceeds that given in the catalogue, the lower end of the polar axis will be to the W. of its true place, and must be moved accordingly. On the other hand, should the observed declination be less than that given in the catalogue, the lower end of the polar axis is too far E., and must be shifted.

Should the star observed be W. of (past) the meridian, the effects of the erroneous position will be reversed, and the adjustments must be reversed also.

Example. The declination of α Ursæ Majoris when 6^h W. of the meridian was observed to be $62^{\circ} 36' 11.0''$, the face of the circle being W. Correcting this for the index-error found above ($16.5''$), and for refraction ($30.8''$), the result was $62^{\circ} 36' 23.7''$. The declination by the catalogue was $62^{\circ} 35' 16.3''$. Hence the lower end of the polar axis was $7.4''$ E.

If the other adjustments are perfected the possessor of a Transit Instrument and Sidereal Clock may adopt a simpler plan for bringing his Equatorial to the meridian. Calculate the exact apparent instant of the transit of a star near the Equator and carefully levelling the Declination Axis, make the middle vertical wire of the Transit eye-piece (on the Equatorial) bisect the star at the instant of its meridian passage (as indicated by the clock) by means of the screws which move the lower end of the polar axis.

4th adjustment.—*To place the optical axis of the telescope at right-angles to the declination axis.*

Put in a transit eye-piece, and observe the time of the passage of some star over the centre wire, and read off the hour-circle. Turn the polar axis half round; observe a second passage, note the time, and again read off the hour-circle. If the interval of time between the two observations corresponds exactly to the difference between the two readings of the circle, all is right; if not, it is evident that one of the transits has been observed too

^h A formula for this is given in Loomis's *Pract. Ast.*, p. 29.

early and the other too late, on account of the erroneous position of the wires. One half the difference between the interval as measured by the clock and as measured by the hour-circle will be the error of collimation, as it is usually called.

Example. The following observations were made upon the star δ Ophiuchi:—

Face of Circle.	Sidereal Time.			Hour Circle.		
	h.	m.	s.	h.	m.	s.
W.	16	12	58.8	0	6	51.0
E.	16	19	9.7	0	13	0.5

The interval in time was $6^m 10.9^s$; the difference of the circle readings $6^m 9.5^s$. The two intervals differed, *inter se*, 1.4^s . One-half of this is 0.7^s , which is the error of collimation, to be added to the readings of the hour-circle when the circle is E., and subtracted when the circle is W. The error may be corrected by the proper screws if the amount is considerable.

It is desirable that the star chosen should be situated as near as possible to the equator, because the apparent angular motion of the sphere is faster at that point than elsewhere.

5th adjustment.—*To set the polar and declination axes at right angles to each other.*

Place a striding spirit-level upon the cylindrical pivots on which the declination axis turns, and by moving the hour-circle bring the bubble to the middle of its run. The declination axis will then be horizontal¹. Read the hour-circle; turn the polar axis half round; again bring the declination axis into a horizontal position, and again read the hour-circle. If the readings are the same (or where the circle is graduated to 24^h , differ exactly by 12^h) in both positions, the declination axis is in adjustment. If the readings do not agree, the declination axis is not perpendicular to the polar axis. If the declination axis is furnished with adjusting screws, place the hour-circle half-way between the position which it actually has and that which it ought to have in order that the readings may differ by exactly

¹ This supposes the level to be itself in adjustment. If not in adjustment, it must be put so before proceeding

further. For tests connected with levels see Loomis's *Pract. Ast.*, pp. 46-7.

12 hours, and make the declination axis horizontal by the screws.

This adjustment ought to be performed by the maker, and when once properly effected is not liable to derangement.

6th adjustment.—*To make the index of the hour-circle point to 0^h when the telescope is placed in the meridian; that is to say when the declination axis is horizontal.*

Set the declination axis horizontal by a level; then if the previous adjustments have been duly performed, the instrument will be in the meridian, and the index may be set to zero at once.

A more precise plan is the following: clamp the telescope approximately in the meridian; observe the transit of one or more known stars not far from the equator, and allow for the error of the clock. Then since the R.A. of the star = the true sidereal time of observation \pm the true hour angle from the meridian, the true hour angle is known, and the index may be set to mark it.

It is also requisite that the polar axis should be at right-angles to the plane of the hour-circle. This however is hardly to be called an adjustment, as it ought to be provided for by the maker before the instrument leaves the workshop.

It is desirable that all these adjustments should be performed (the third, of course, excepted) with the telescope as near the meridian as possible, this being the most favourable position of the instrument, as ordinarily constructed, for symmetry and strength; moreover, the correction for refraction is applied with greatest facility under these circumstances.

The equatorial being now in adjustment, is ready for use. A few remarks on this subject may not be out of place. Let us suppose that it is required to find a certain star whose R.A. is $16^{\text{h}} 40^{\text{m}}$ and Declination $+45^{\circ} 47'$, and that the time shown by the sidereal clock is $12^{\text{h}} 16^{\text{m}}$. As the R.A. of the star is greater than the sidereal hour on the meridian, the star sought for has not yet come to the meridian. Subtracting $12^{\text{h}} 16^{\text{m}}$ from $16^{\text{h}} 40^{\text{m}}$, we have $4^{\text{h}} 24^{\text{m}}$ as the East hour angle. Turn the

telescope to the East, and set it to the reading, 12^{h} less $4^{\text{h}} 24^{\text{m}}$, or $7^{\text{h}} 36^{\text{m}}$ of the hour-circle; then setting the declination circle to $45^{\circ} 47'$ North, the object sought should be seen in the centre of the field. With a little practice in this way the observer will soon be able to fix his telescope upon an object, a small allowance being made to the circle reading for the effect of refraction.

Let us take now the converse of this proposition. Suppose that the observer suddenly picks up an unknown comet, and desires to obtain a record of its place. If he is content with an approximation to the truth, he may proceed thus. Let the comet be placed by the eye in the centre of the field, the time noted, and the circles read off, and the observer will then possess all the required data.

For instance, suppose that at $13^{\text{h}} 25^{\text{m}}$ sidereal time a comet is seen in the field of the telescope, the hour angle of which is $4^{\text{h}} 17^{\text{m}}$ West, and the declination circle $-9^{\circ} 35'$, what is the comet's position?

Seeing that in this case the object is $4^{\text{h}} 17^{\text{m}}$ past the meridian, and that the hour on the meridian ("sidereal time") when the observation was made was $13^{\text{h}} 25^{\text{m}}$, it is clear that the R.A. of the comet is $13^{\text{h}} 25^{\text{m}}$ less $4^{\text{h}} 17^{\text{m}}$, or $9^{\text{h}} 8^{\text{m}}$; and the Declination $9^{\circ} 35'$ South.

If the observer is not content with an approximate position, a micrometer must be called into requisition and a *star of comparison* selected. The principle of procedure to be adopted is this: the difference between the Right Ascension and the Declination of the comet and star is ascertained by measurement^k, and the position of the star being known from a standard catalogue, the position of the comet is readily ascertained.

For instance, suppose that the R.A. of a standard star is $16^{\text{h}} 16^{\text{m}} 35.4^{\text{s}}$, and its Declination $+47^{\circ} 15' 37''$, and that it is found that a comet precedes the star in question by 2.7^{s} , and is North of it $4' 21''$ in Declination, what is the comet's position?

^k Or its R.A. is determined by clamping the equatorial and noting the interval of time between the transit over the

micrometer wire of the comet and star respectively.

	R.A.			Decl.			
	h.	m.	s.	°	'	"	
Star	16	16	35.4	+ 47 15 37
Subtract			2.7	...	Add	...	4 21
True R.A.	16	16	32.7	True Decl.	+	47	19 58

In practice, index errors and correction for refraction must be scrupulously taken into account when precision is aimed at¹.

An arrangement has been introduced of late years which greatly facilitates the employment of the equatorial. The graduated hour-circle revolves freely on the polar axis; below it is *fixed* an index, which is (or should be) exactly in the meridian; immediately above the moveable circle is another circle, fixed to the polar axis, not graduated, but carrying another index which coincides with the lower one when the telescope is in the meridian. To find an object, all that the observer has to do is to bring to the fixed index that point on the moveable hour-circle which corresponds to the R.A. of the object sought; to clamp the same, and then to shift the upper circle till the index which it carries points to the hour on the hour-circle corresponding to the sidereal time shown by the clock. The telescope being duly set in Declination, the object will be found in the field. The time and trouble saved by this simple expedient can only be fully appreciated by actual experience. Grubb has slightly varied this arrangement and in a manner which is, if possible, still more conducive to rapid work. He employs 3 concentric hour-circles, and puts on the 3rd, or lowest one, the index spoken of above as “fixed.”

¹ Sir H. Grubb has propounded a scheme for making the adjustments of an Equatorial which differs materially in its details from the foregoing; and he claims for it various advantages of simplicity

and convenience. (*Journ. Liverpool Ast. Soc.*, vol. iii. p. 1, 1884; *Observatory*, vol. viii. p. 9, Jan. 1885; vol. viii. p. 43, Feb. 1885.)

CHAPTER IV.

THE TRANSIT INSTRUMENT.

Its importance.—Description of the Portable Transit.—Adjustments of the Transit.—Four in number.—Method of performing them.—Example of the manner of recording Transit observations of Stars.—Of the Sun.—Remarks on observations of the Moon.—Of the larger Planets.—Mode of completing imperfect sets of Transit observations.—The uses to which the Transit Instrument is applied.

BY far the most important of the astronomical instruments used in a permanent observatory is the Transit, or Transit-Circle, the smaller and less perfect kinds being chiefly used for taking the time, and the larger for measuring the positions of stars, &c. for forming catalogues.

I shall only describe the small, or Portable Transit (see Fig. 79).

The instrument consists of 3 principal parts—the telescope, the stand, and the circle: $a b$ is a telescope of a large field and low power, the tube of which is in 2 parts, which are connected by a cubical centre-piece, into which, at right-angles to the optical axis, are fitted the larger ends of 2 cones c, c' , which form the horizontal axis of the telescope; the smaller ends of each cone are accurately ground to 2 perfectly equal cylinders or pivots. These pivots rest on Y's, angular bearings which surmount the 2 side standards, e and w , of which e may be called the eastern, and w the western. One of the Y's is fixed in a horizontal groove, so that by means of a screw a small azimuthal motion may be imparted to the instrument; in like manner a small motion in altitude may be obtained by turning the foot-screw g . On one

end of the axis is fixed, so that it may revolve with it, a declination circle, *d* (for "setting"), divided to degrees and read by verniers to minutes, &c. Over this is fixed a level, *f*. The other cone is hollow, in order that light coming from the lamp, *h*, may pass to the centre-piece, where there is a plane pierced mirror inclined at an angle of 45° , which reflects the light to the wires

Fig. 79.

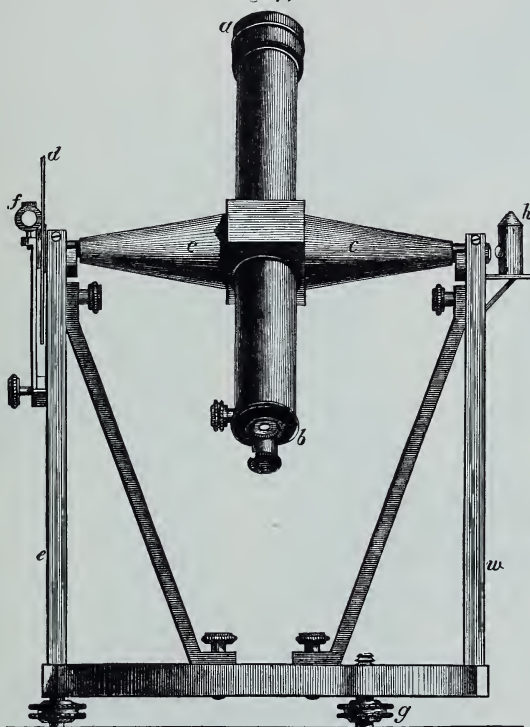

THE PORTABLE TRANSIT INSTRUMENT.

placed in the principal focus. There are usually 4 or 6 wires; in the former case, 1 is placed horizontally and 3 vertically; in the latter, 1 horizontally and 5 vertically. The lamp is furnished with a sliding diaphragm, by which the quantity of light allowed to pass out may be increased or diminished as may be required. A striding level is furnished with the instrument^a, to be used,

^a For a good account of the principles of the striding level, see A. R. Grant's *Plane Astronomy*.

when required, for adjusting the axis. It is needless to say that it is of paramount importance that all the parts should be

Fig. 80.

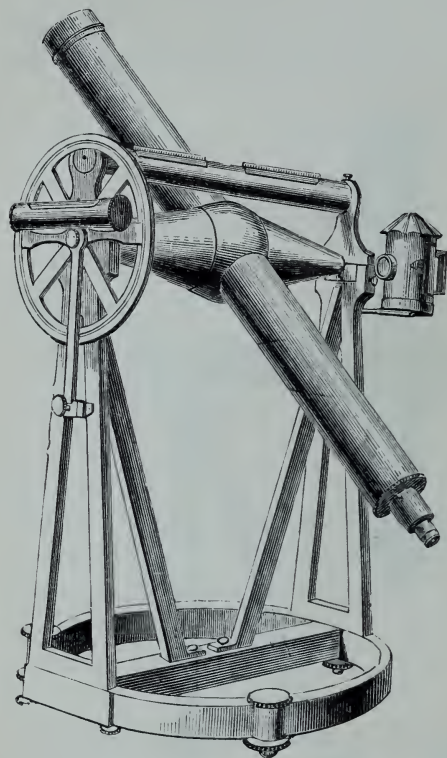

THE PORTABLE TRANSIT INSTRUMENT.

perfectly rigid and free from the slightest flexure, for this would vitiate the observations.

Fig. 81 is a Transit Instrument of modern form by Cooke of York. The more substantial character of the mounting will at once attract notice, contrasting Fig. 81 with Figs. 79 and 80, which may be said to represent the prevalent type of 50 years ago.

Fig. 82 represents the Transit Instrument of the Bedford Observatory. It was made by Troughton. It may be added that Troughton's pattern was followed by other makers with scarce a semblance of change for half a century.

Fig. 84 represents a form of portable Transit Instrument, made, so far at least as the telescope is concerned, upon the plan of the Universal Instrument of Reichenbach; a prism or diagonal plane of polished speculum-metal being so fixed within the sphere *a*, as that the rays from the object-glass are reflected through the axis in which the eye-piece and diaphragm are accordingly fitted. The observer's place is therefore at *b*, and whatever may be the altitude of the observed object, his position remains unaltered; nor has he to change his place in order to set the telescope to the required altitude, for the graduated circle *c* is before him;

and if the clock be placed so as to be seen in the same direction, nothing can exceed the ease and comfort with which transit observations may be made with such an instrument. The horizontality of the axis is effected by an ordinary striding level, which in this case passes over the circle *c*, and therefore requires

Fig. 81.

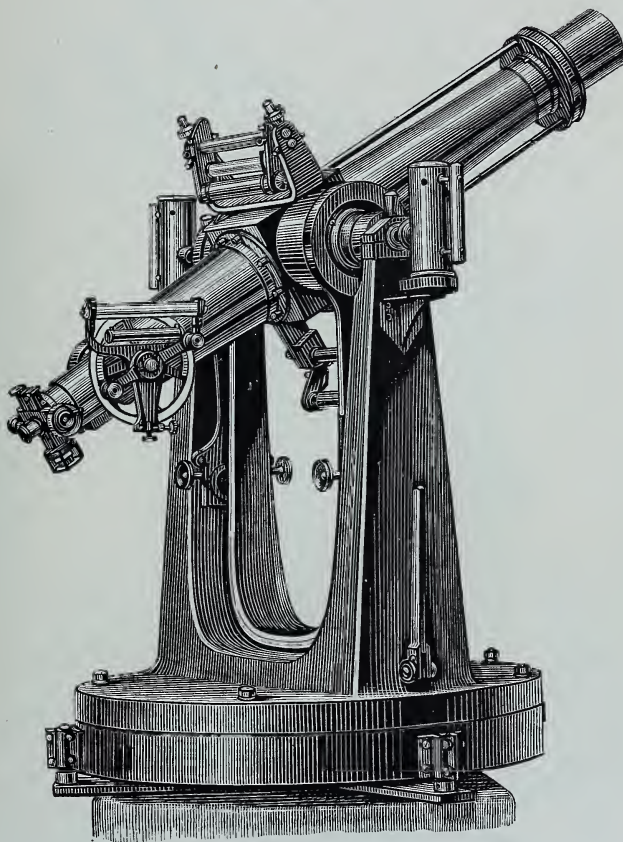

TRANSIT INSTRUMENT, WITH REVERSING ARRANGEMENT AND TWO SETTING CIRCLES.

longer supports than in the ordinary instrument, but it is secured against accident by a small cylindrical pin which drops into the fork *d*. The meridian adjustment is made by turning the head *e*.

The field of view in the Universal Instrument of Reichenbach is illuminated by means of a reflector placed in front of the object

glass; for the prism within the sphere *a* intercepting the light passing directly through the perforated pivot appeared to make

Fig. 82.

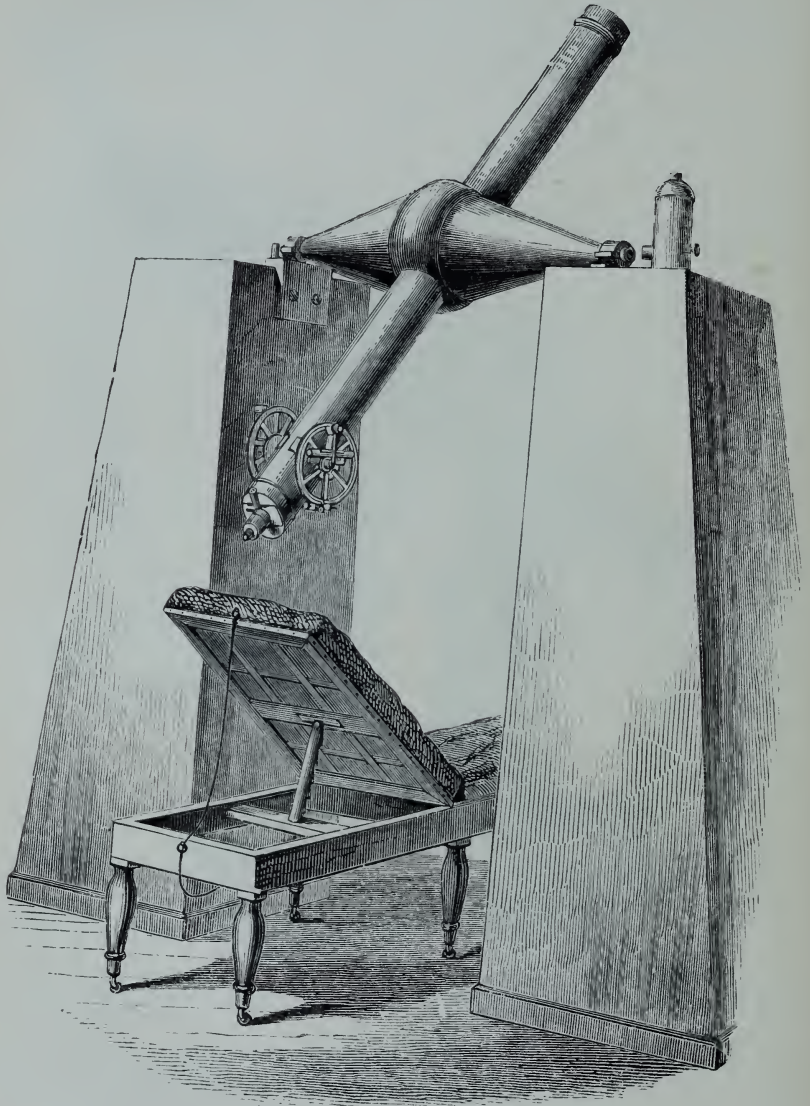
THE TRANSIT INSTRUMENT OF THE BEDFORD OBSERVATORY^b.

^b This is referred to again in Chapter VII., *post*.

this mode of illumination impracticable; but in the Transit Instrument now being described this difficulty is surmounted by the introduction of a lens, of which three small segments project beyond the sides of the prism. Now the light from the lamp falling

Fig. 83.

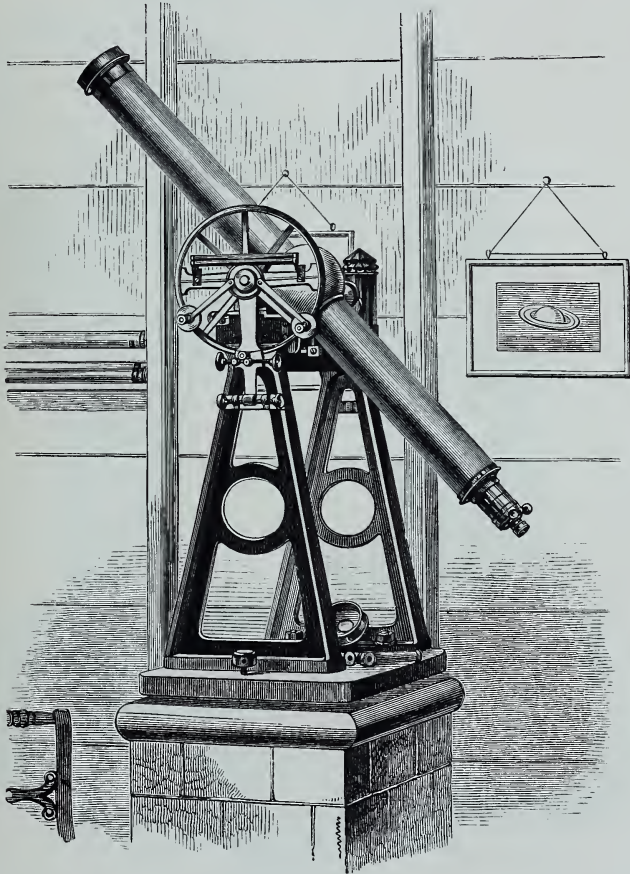

THE TRANSIT INSTRUMENT OF THE FERNHILL OBSERVATORY. (I. W.)

upon a lens at the extremity of the pivot is thereby made to diverge upon the projecting segments of the lens first mentioned, and is thence conveyed to the field of view, which it completely illuminates. The tube *f* merely serves to balance the object-end

of the telescope, and may also be conveniently used as a handle when setting the telescope to any required altitude. In the instrument from which the preceding figure was drawn, the telescope tube is at one end of the axis and the circle at the

Fig. 84.

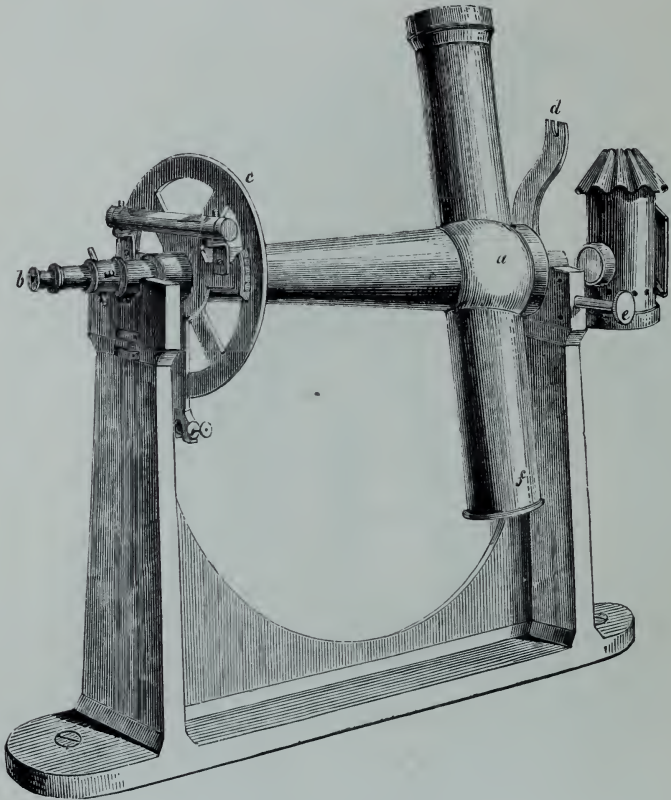

THE SIDE-TRANSIT INSTRUMENT.

other, which insures a perfect balancing and an equal pressure upon the bearings, with the least possible weight in the several parts; but the excentricity of the telescope makes it less easy to correct the line of collimation than in the case of the ordinary transit instrument.

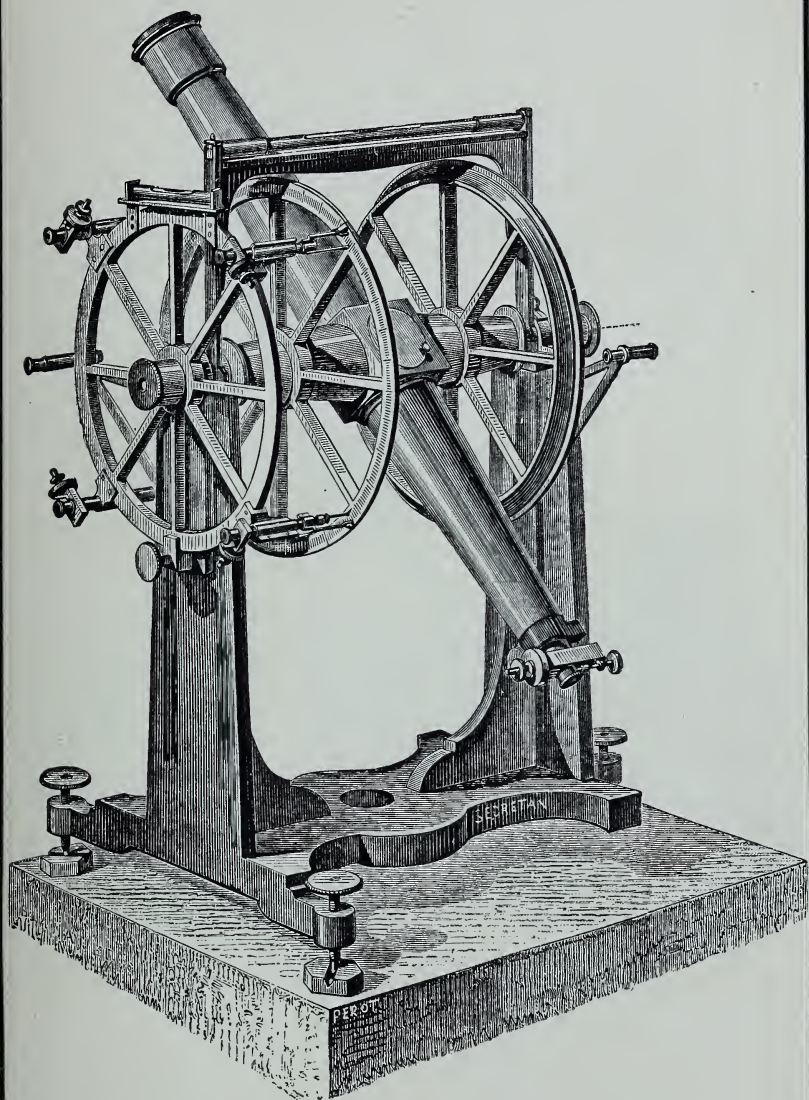

TRANSIT CIRCLE OF FRENCH MANUFACTURE.

(By Secrétan.)

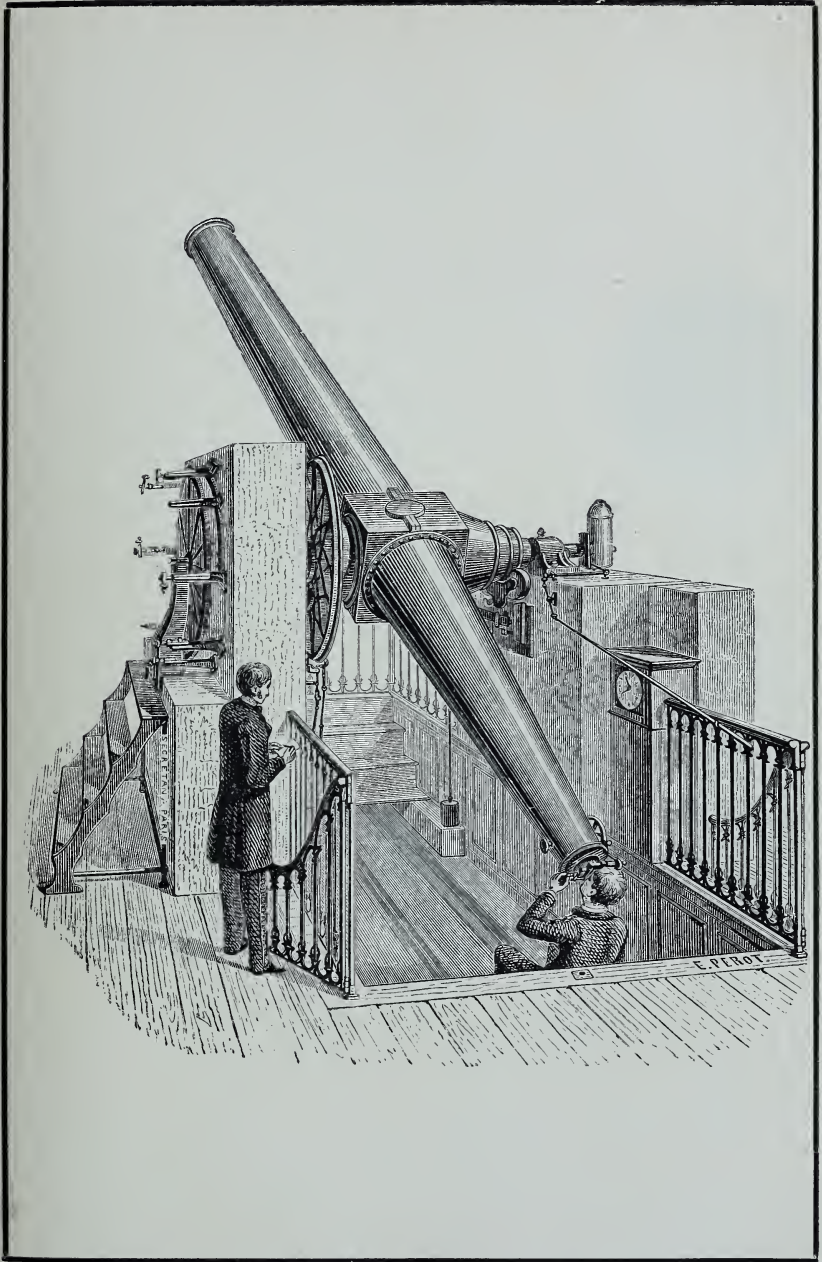

TRANSIT CIRCLE OF FRENCH MANUFACTURE.

(By Secrétan.)

The transit adjustments are 5 in number^o. For correct observation it is necessary—

1. *That the wires and the object be in focus.* [Unless this is so, a lateral movement of the observer's head will cause an apparent movement of the wires.] This is called the adjustment for *parallax*.

2. *That the axis on which the telescope moves be horizontal.* This is the adjustment in *level*.

3. *That the line of sight move in a vertical circle, perpendicular to the horizontal axis.*

4. *That the centre wire be exactly in the optical axis of the telescope.* This is the adjustment of the line of collimation.

5. *That the vertical circle described coincide with the plane of the meridian.* This is the adjustment for azimuth.

1st adjustment. *Parallax.* Focus the wires accurately by means of the moveable tube which carries the eye-piece; turn the telescope on some well-defined and distant object; and if on moving the eye laterally the object still remains bisected or covered, as the case may be, the instrument is in adjustment for parallax. If, however, the object appears to move with respect to the wires when the eye moves, the wires must be shifted in the tube^d experimentally till the parallax be destroyed. This adjustment frequently occasions some trouble, but when once properly performed it should seldom require renewal. The maker ought to attend to it^e.

^o As this volume is designed mainly for amateurs, and as amateurs rarely make use of the transit instrument for any other purpose than that of determining the time, transit-observation corrections, and expedients of a technical character, required for the work of large observatories, will be passed over. For these see Loomis's *Pract. Ast.*, pp. 39-82. For the same reason nothing is said about the question of "Personal Equation" or that physical difference which subsists between observers in virtue of which

they will differ *inter se* by a more or less permanent fraction of a second in their estimates of absolute moments of time in such matters as the transit of stars across wires. (See Challis, *Lectures on Practical Astronomy*, p. 123, and the references there given.)

^d The correction would be obtained by letting alone the wires and shifting the object-glass instead, but common sense dictates which is the better expedient.

^e If the wires should be accurately fixed in the focus of the object-glass, then

Fig. 87.

ARRANGEMENT OF WIRES
IN A TRANSIT
INSTRUMENT.

2nd adjustment. *To make the axis on which the telescope moves to be horizontal.*

Place upon the pivots the striding level, and bring the air-bubble to the centre of its run by turning the screw which is under one of the pivots or one of the standards (see Fig. 79). Turn the level, end for end, and if the bubble retains its middle position the axis is horizontal, but if it does not it must be brought back, half by the pivot-screw and half by the small vertical adjusting-screw at one end of the level. The operation must be repeated several times if needs be, till the result is satisfactory^f.

3rd adjustment. *To make the line of sight move in a vertical circle perpendicular to the horizontal axis.*

Turn the telescope on some distant, small, and well-defined terrestrial object, and bisect it with a centre wire, giving to it, if necessary, an azimuthal motion by means of the screw. Elevate or depress the telescope to see whether the object still remains bisected in every part by the middle wire; if not, loosen the screws which hold the eye-end of the telescope in its place, and turn the end round very carefully until the error is removed.

4th adjustment. *To bring the centre wire exactly to the optical axis of the telescope.*

Lift up the whole instrument bodily from the Y's and reverse it, end to end: if the object is still bisected by the centre wire, the collimation in azimuth is perfect; but if not, move the centre of the cross wires half-way towards the object by turning the small screws which hold the wire plate, and if this half-distance has been correctly estimated, the operation of adjustment will be complete. Again bisect the object by the centre of the cross wires by turning the azimuthal screw, and repeat the operation till the object is bisected by the centre of the cross wires in both positions of the instrument, and then the adjustment will be known to be perfect.

if a star be bisected by the horizontal wire and an upward motion of the eye moves the star in the same direction, the eye-piece must be pulled out. But if the upward motion of the eye displaces the

star downwards, push in the eye-piece.

^f It is here assumed that the level itself is in order. Tests connected with levels will be found in Loomis's *Pract. Ast.*, pp. 46-7.

5th adjustment. *To make the vertical circle, described by the telescope when moving on its horizontal axis, coincide with the plane of the meridian.*

The axis of rotation being truly level, and the line of sight (or collimation) describing a great circle, the vertical circle passes through the zenith, and therefore cuts the meridian; if, then, we can make it touch another part of the meridian, it follows that it will everywhere coincide with the meridian.

Choose 2 stars differing but little in R.A., one crossing the meridian in or very near the zenith, the other as near the S. horizon as may be. The axis of the instrument being supposed level, the vertical circle will pass through the meridian at the zenith, however far removed therefrom at the horizon. A star *in* the zenith will therefore appear to cross the meridian at the time it actually does cross, but such will not be the case with a star remote from the zenith. If the low star passes the meridian too early, as compared with the computed time of transit, the plane of the instrument deviates to the E.; if it passes too late, the plane deviates to the W. In either case the error must be corrected by the azimuth-screw, until stars at all altitudes indicate the same amount of clock-error^g.

The reason why the stars selected should differ but slightly in R.A. is that the clock employed may not be going uniformly, and therefore the observer, if he finds a discrepancy, will have no means of deciding what proportion is due to error in azimuth and what to error in the rate of his clock; therefore by taking stars which pass the meridian in close succession, chances of error from the latter cause are reduced to a minimum.

I have explained now all that is *essential* to this method: repeated star observations, and repeated trials of azimuthal-screw turning, will enable the observer to bring his instrument into perfect adjustment; but if he is not averse from a little calculation, *one* pair of stars will enable him to complete the

^g If the time be obtained from a zenith star in the manner described in the text, and then—without disturbing the level—the centre wire be made (by means of the

azimuth screws) to bisect the Pole-star at the instant of its meridian passage, the instrument will be very nearly indeed in the meridian.

adjustment. And if bad weather comes on, it may be convenient to know how to do this.

Take the difference between the observed times of passage of the 2 stars, and also the difference of their computed Right Ascensions (calling the differences + when the lower star precedes the higher, and - when it follows it); if these differences be exactly equal, the instrument is exactly in the plane of the meridian: if they are not equal, their difference (that is to say, the difference of the observed times of transit *minus* the difference of the computed Right Ascensions) will point out a deviation from that plane to the E. of S. when it is +, and to the W. when it is -.

Let δ be the difference of times *minus* the difference of R.A., π and π' the North Polar distances of the higher and lower stars, and λ the latitude of the place of observation; then x , representing the deviation of the instrument in seconds of time, will be found by the formula—

$$x = \delta \sin \pi \sin \pi' \operatorname{cosec} (\pi - \pi') \sec \lambda.$$

Or, in words ^h, To the log. of the difference of times, *minus* the difference of R.A.'s, add the log. sin. of the N. P. D. of the higher star, the log. sin. of the N. P. D. of the lower star, the log. cosec. of the difference of the N. P. D.'s, and the log. sec. of the latitude. The sum will be the log. of the azimuthal deviation, which, multiplied by 15, will be the deviation in arc.

The value of a revolution of the azimuthal screw must next be determined.

Note the sidereal time of the passage of an equatorial star across the centre wire; turn the screw quickly through a revolution, so as to bring the wire to the W. of the meridian, and then note the time of the second passage: the interval between these 2 passages will then be the value in time of 1 revolution of the screw. Reduce this to arc by multiplying by 15 sin. N. P. D.

^h The lower star may be near the Northern horizon, so far as the principle of this rule is concerned; but as practically a Southern Star is preferable, and

it is possible to abbreviate the expression of the rule by confining one's attention to such a star, the terms of the above method are modified accordingly.

The following modification of this method will yield a better result at the cost of a little more trouble:—

Determine the clock-error by 3 or 4 stars of nearly the same declination, and following one another in as close succession as possible, in order to eliminate chances of error through want of uniformity in the rate of the clock. Turn the azimuthal screw through several revolutions, and take a second batch of stars; then the difference of the clock-error shown by the two sets, divided by the number of revolutions, will be the value of 1 revolution. Reduce as before.

The value of 1 revolution, and the azimuthal deviation by the former portion of the calculation being known, the instrument may be readily brought into the meridian. Then another pair of stars should be taken to ascertain the result of the operations.

EXAMPLE.

Observations taken at East-Bourne, Sussex, July 11, 1858:—

	Observed Passage.			...	<i>Naut. Alm.</i>		
	h.	m.	s.		h.	m.	s.
High star, α Coronæ	15	28	6.26	...	15	28	40.41
Low star, δ Ophiuchi	16	6	20.50	...	16	6	53.83
			-38				-38
			14.24				13.42
			-38				-38
			13.42				

- 0.82 Discrepancy.

Therefore the instrument was W. of S.

Discrepancy 0.82 ^s	...	log.	=	9.9138139
π = N.P.D. of α Coronæ	62° 48'	...	log. sin.	= 9.9491051
π' = N.P.D. of δ Ophiuchi	93° 19'	...	log. sin.	= 9.9992720
$\pi' - \pi$ = diff. of N.P.D.	30° 31'	...	log. cosec.	= 0.2943167
λ = lat. of East-Bourne	50° 46' 22"	...	log. sec.	= 0.1990088

$$2.2674^s = 0.3555165$$

15

$$113370$$

$$22674$$

$$34.0110$$

Therefore the azimuthal deviation was 34.01" W. of S.

The following will be found convenient pairs of stars for latitudes in the south of England, say 50° N.:—

$\left\{ \begin{array}{l} \alpha \text{ Cassiopeiæ,} \\ \beta \text{ Ceti.} \end{array} \right.$	$\left\{ \begin{array}{l} \alpha \text{ Hydræ,} \\ \theta \text{ Ursæ Majoris.} \end{array} \right.$	$\left\{ \begin{array}{l} \gamma \text{ Draconis,} \\ \mu^1 \text{ Sagittarii.} \end{array} \right.$
$\left\{ \begin{array}{l} \alpha \text{ Ursæ Majoris,} \\ \theta \text{ Ceti.} \end{array} \right.$	$\left\{ \begin{array}{l} \gamma \text{ Ursæ Majoris,} \\ \epsilon \text{ Corvi.} \end{array} \right.$	$\left\{ \begin{array}{l} \rho \text{ Capricorni,} \\ \alpha \text{ Cygni.} \end{array} \right.$
$\left\{ \begin{array}{l} \alpha \text{ Persei,} \\ \epsilon \text{ Eridani.} \end{array} \right.$	$\left\{ \begin{array}{l} \alpha \text{ Canum Vena-} \\ \text{ticorum,} \\ \alpha \text{ Virginis.} \end{array} \right.$	$\left\{ \begin{array}{l} \alpha \text{ Cephei,} \\ \beta \text{ Aquarii.} \end{array} \right.$
$\left\{ \begin{array}{l} \epsilon \text{ Leporis,} \\ \alpha \text{ Aurigæ.} \end{array} \right.$	$\left\{ \begin{array}{l} \alpha \text{ Libræ,} \\ \beta \text{ Ursæ Minoris.} \end{array} \right.$	$\left\{ \begin{array}{l} \alpha \text{ Piscis Austra-} \\ \text{lis,} \\ \alpha \text{ Pegasi.} \end{array} \right.$
$\left\{ \begin{array}{l} \epsilon \text{ Ursæ Majoris,} \\ \alpha \text{ Hydræ.} \end{array} \right.$	$\left\{ \begin{array}{l} \delta \text{ Ophiuchi,} \\ \beta \text{ Draconis.} \end{array} \right.$	$\left\{ \begin{array}{l} \gamma \text{ Cephei,} \\ \delta \text{ Sculptoris.} \end{array} \right.$

The vertical wires are placed by the maker as nearly as possible equidistant and parallel to the centre one, and likewise the horizontal wires at right-angles to the vertical ones.

The instrument being thus in complete adjustment, observations may be commenced¹. Fig. 88 will serve as a useful reminder that when the telescope is directed towards the S. the celestial bodies enter the field of view on the W. side and quit it on the E. The star in the figure is just going out of the field and the planet Venus has just come in.

The observer being conveniently seated with the circle set to the Declination of the star to be taken, so soon as it enters the field, takes from the clock a second, and continues the reckoning mentally till the star passes the first wire; if this is exactly coincident with the beat of the clock, the figure is noted down; if, however, as is usually the case, the star passes the wire between one beat and another, then the exact instant must be

¹ With large instruments it is found preferable not to attempt to bring them into *perfect* adjustment, but when nearly so to take into account residual errors by constants of correction. The amateur who simply requires to find the time has no need to trouble himself with these

niceties. At the same time, if he is ambitious of accomplishing results in advance of ordinary amateurs he will do well to consult a paper on 'Time Observations' in *Sider. Mess.*, vol. iii. p. 209, Sept. 1884.

estimated and set down as a decimal of a second^k. This is to be done for all the wires, and a mean being taken a result will be obtained more trustworthy than that which would have been obtained from the centre wire singly^l.

The observations are then reduced as below; the sum of the seconds is multiplied by 0.2 (equivalent to dividing by 5). To make the product coincide with the middle wire it may be

Fig. 88.

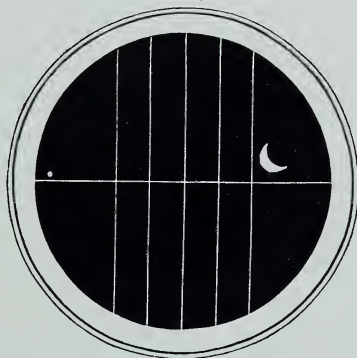

THE PLANET VENUS AND A STAR AS SEEN
IN A TRANSIT INSTRUMENT.

requisite to add or subtract 12 or 24 to the product if there has been a change of minute in the course of the time occupied by the star in crossing the 5 wires. The amended figures are then set forth in juxtaposition with the computed R.A. of the star, and so the clock-error is arrived at. If the computed time be less than the observed, the clock is fast, and *vice versâ*.

^k It was Maskelyne who adopted in 1772 the practice of dividing decimally the seconds in Transit observations. Before his time astronomers had been content to record simply the nearest second, though Bradley sometimes estimated to the half or third of a second. Maskelyne tried eighths before finally adopting tenths of a second.

^l This method of taking Transits is called the "Eye-and-ear" method, to distinguish it from the mechanical but more modern and more exact system of the Chronograph. For some account of the Chronograph and its use see Challis, *Lectures on Practical Astronomy*, p. 120; Lockyer, *Stargazing*, p. 260; and p. 215, *post*.

EXAMPLES.

The following transits were taken at Uckfield on Sept. 15, 1864, by 2 different observers:—

		β Draconis.		α Aquilæ.		ϵ Pegasi.	
		m.	s.	m.	s.	m.	s.
Wire	I ...	44.4	...	48.9	...	11.4	...
	„ II ...	4.5	...	1.9	...	23.8	...
	„ III ...	27 24.3	...	44 14.1	...	37 35.9	...
	„ IV ...	44.7	...	26.8	...	48.7	...
	„ V ...	3.9	...	38.4	...	0.5	...
		<hr/>		<hr/>		<hr/>	
		121.8		130.1		120.3	
		.2		.2		.2	
		<hr/>		<hr/>		<hr/>	
		24.36		26.2		24.06	
				-12		+12	
		<hr/>		<hr/>		<hr/>	
				14.02		36.06	
		<hr/>		<hr/>		<hr/>	
	R.A. of Star ...	17 27 22.63	...	19 44 12.27	...	21 37 34.32	
	Obs. Pass. ...	17 27 24.36	...	19 44 14.02	...	21 37 36.06	
	Clock	+ 1.73		+ 1.75		+ 1.74	

The three results differ by only $\frac{1}{100}$ of a second! As the stars differed in time by 4^h, and in Declination by 44°, it was reasonable to infer that not only was the clock-rate uniform but that the instrument was also in adjustment in azimuth.

The Sun, Moon, and larger planets may be turned to account for ascertaining the time, but the observations are more troublesome and the results less trustworthy, being dependent upon the errors of the Tables of those bodies, as well as requiring an accurate knowledge of their semi-diameters^m.

In taking observations of the Sun, the time of the transit of its centre is the time required, but as it would be impossible to estimate this accurately, the time of each limb coming in contact with each wire is noted, and a mean then gives the required result. If only one limb be observed, to the mean of the passage over each wire must be added, or from it must be

^m Observers who wish to obtain practical advice as to the carrying out of Transit observations of planets may con-

sult Challis's *Lectures on Practical Astronomy*, p. 105.

subtracted (according as the 1st or 2nd limb is observed), the duration of the passage of the semi-diameter as given in the *Nautical Almanac*, and the result must be compared with the time of the transit of centre there stated.

EXAMPLE.

The following transit of the Sun was taken at Uckfield on Sept. 16, 1864:—

		☉'s 1st limb.			☉'s 2nd limb.		
		h.	m.	s.	h.	m.	s.
Wire	I	...	30	0	...	38	0
"	II	...	42	8	...	50	0
"	III	II 39	54	7	II 42	2	5
"	IV	...	7	8	...	15	5
"	V	...	19	2	...	26	8
		154.5			132.8		
		.2			.2		
		30.90			26.56		
		+ 24			- 24		
		54.90			2.56		

Combining these two results:—

h.	m.	s.
II	39	54.90
II	42	2.56
2) 23 21 57.46		
II	40	58.73 = Observed passage.

Then combining this with the computed passage (Right Ascension) as given in the Almanac we have:—

R. A. of Sun	h.	m.	s.
Obs. pass.	II	40	56.51
				II	40	58.73
				Clock	+ 2.22	

In taking transits of the Moon, the bright limb only in general can be observedⁿ. The time of the centre transit can however be approximately deduced by the use of tables.

ⁿ Sometimes when the Moon is very near its full phase both limbs are observed, a correction for defective illumination being applied if necessary to one of them.

As to this see Challis, *Lectures on Practical Astronomy*, p. 107; but no amateur will care to waste time over such a problem.

In observing transits of the larger planets, it is recommended that one limb be observed at the 1st, 3rd, and 5th wires, and the other at the 2nd and 4th; then the mean of these observations will give the passage of the centre.

In practice it will frequently happen that owing to clouds, or other causes, the transit of an object across all the wires cannot be noted. In this case, provided the star's Declination be known, the imperfect set of observations can be reduced without difficulty to the centre wire; and thus the instant of meridian passage can be ascertained.

If, however, observations at corresponding wires—as, for instance, the 1st and 5th, or the 2nd and 4th—have been obtained, and the angular interval between the wires is exactly the same, the time for the centre wire can be arrived at by simply taking a mean. On the other hand, supposing, as will usually be the case, that the wires observed are not only not corresponding ones, but are not all equally distant from the centre wire, a formula of reduction must be employed.

The *equatorial* intervals of the wires must first be ascertained: that is, the time occupied by stars *exactly* on the equator in passing from wire to wire.

Take a star the Declination of which is known.

To the log. of the interval occupied by the star in passing from any wire to the centre wire add the log. cosine of the star's Declination: the sum, rejecting 10 from the index, will be the log. of the equatorial interval.

Having determined the intervals for all the wires several times over by stars of different Declinations, a mean of each may be taken and kept as a constant.

The observer is now in a position to complete an imperfect transit.

To the log. of the equatorial interval add the log. secant of the star's Declination; convert the product into its natural number, and subtract the same from, or add it to, the time of the centre wire, according as the missing wire precedes or follows the centre one.

EXAMPLE.

By a transit of α Leonis (Declination $+12^\circ 37' 36.5''$) the following wire-intervals were found:—

I to centre	25.1 ^s	Centre to IV	12.6 ^s
II to centre	12.5	Centre to V	24.5

And on Sept. 15, 1864, observations of 16 Pegasi over 4 wires were obtained as follows:—

Wire	I	II	III	IV	V	h.	m.	s.
			31.7
„	II			—
„	III	21	46	58.5
„	IV			11.7
„	V			24.6

Fill in the missing wire, and deduce the error of the clock.

Here the missing wire was the 2nd, and by α Leonis the interval between the 2nd and centre wires was 12.5^s: the equatorial interval corresponding to this must first be found:—

Interval 12.5 ^s	log.	= 1.0969100
Decl. of α Leonis, $+12^\circ 37' 36.5''$...	log. cos.	= 9.9893674
		log. eq. int. = 1.0862774

The transit can now be completed.

Interval of wires II and III	log.	= 1.0862774
Decl. of 16 Pegasi, $+25^\circ 17' 41.1''$...	log. sec.	= 10.0437711
		log. 1.1300485 = 13.491 ^s

The missing wire therefore preceded the centre wire by 13.491^s, and the whole result^o becomes:—

Wire	I	II	III	IV	V	h.	m.	s.
			31.7
„	II			45.0
„	III	21	46	58.5
„	IV			11.7
„	V			24.6
								171.5
								.2
								34.30
								+ 24
								58.30

R. A. of Star ...	21	46	56.50
Obs. Pass. ...	21	46	58.30
			+ 1.80

^o Though in the example the logarithms are taken out to 7 places of decimals, 5 are usually quite sufficient.

A result fairly accordant with those given on p. 136, when it is borne in mind that the equatorial interval was deduced from a single star.

The large transit instruments to be found in first-class observatories, and commonly termed "Transit-circles," are used for determining with the greatest accuracy the Right Ascensions and Declinations of heavenly bodies. For such purposes the portable Transit is hardly suited, except for approximations, its chief use being to ascertain the time and the latitude ^p.

With reference to the former problem it may be well to mention a fact which probably most people know, namely, that the observed time of the passage of the Sun's centre across the meridian is only the instant of *apparent noon*; the time of *mean noon*, which is used in the civil reckoning of time, must be deduced from the apparent by means of an equation-of-time table ^q.

The time shown by a sidereal clock, when any celestial object crosses the meridian, should coincide with its Tabular Right Ascension. The difference, then, between the time shown by the clock and the R.A. as tabulated is the clock-error, as before explained ^r.

The following is the method for determining approximately in the simplest way the latitude by means of a Transit Instrument:—Observe the Pole-star when on the meridian (either culmination will do, but the upper is preferable), and make it pass along the horizontal wire; read the circle. Reverse the instrument promptly, and again read the circle, levelling the axis both

^p Two papers on determining the latitude with the Transit Instrument will be found in the *Memoirs R.A.S.*, vol. xxviii. p. 235 *et seq.*, 1860, but Struve's method is the best.

^q See Book X., *post*.

^r For a further elucidation of the details connected with the subject of this chapter, the reader is referred to the *English Cyclopædia*, Arts and Sciences div., art. *Transit*; where will be found incomparably the best treatise

on the Transit Instrument extant. It was written, I believe, by the late Rev. R. Sheepshanks, M.A. For an account of the large Transit-circle of the Greenwich Observatory see the *Greenwich Observations*, 1852, Appendix I. For information as to the determination of the longitude of 2 observations, whether by the Transfer of Chronometers, or by Galvanic signals, see Challis, *Lectures on Pract. Ast.*, pp. 251 and 367.

before and after reversal. The two readings will give an arc = twice the Zenith Distance — twice the refraction. Halve the arc and add the correction for refraction due to altitude. This half-sum, increased or diminished by the star's Polar Distance (obtained from the *Nautical Almanac*), according as the upper or lower culmination was observed, = the Zenith Distance of the Pole, which, subtracted from 90° , gives the latitude.

The foregoing method contemplates the circles of the Instrument used being graduated to read small fractions of a minute. Where such is not the case the most simple and trustworthy method of using the Transit Instrument is to place it in the Prime Vertical and note the interval between the passage of a star just S. of the zenith over the Prime Vertical to the E. of the meridian and then to the W. of it.

$$\text{Then:— Tan. lat.} = \frac{\text{Tan. Decl. of Star}}{\cos \frac{1}{2} \text{ interval between the Transits}} .$$

We have hitherto been treating of the Transit Instrument (even in its small and portable form) as an astronomer's instrument and one of the appliances of the observatory, but it must not be forgotten that many other classes of the community besides astronomers need the information furnished by the Transit Instrument. It is essentially a Time-teller, and as such everybody is dependent on it, and though the General Post Office by its telegraph service has done much to distribute accurate time throughout England, yet in many districts of the United Kingdom remote from railways and telegraphs, facilities for obtaining the time are still few.

Figs. 89 and 90 represent 2 forms of Transit Instrument devised by Mr. Latimer Clark, M.I.C.E., which deserve the attention of persons not necessarily astronomers. Mr. Clark's idea was that the Transit Instrument should be treated as not exclusively an observatory appliance, but as an instrument to be used anywhere and everywhere by any person who wishes or needs to know true time. With this object in view he set to work to design an instrument which should be simple in its construction and consequently cheap in cost, and capable of

being handled by the general public. It has a telescope 13^{in} in length with an object-glass $1\frac{1}{8}^{\text{in}}$ aperture. The axis of the tube is of gun-metal, 7^{in} long, the trunnions resting on gun-metal bearings. The altitude or declination circle is $4\frac{1}{2}^{\text{in}}$ in diameter, divided into 4 quadrants of 90° , reading by a vernier to single minutes. It is furnished with three spider-web cross-wires, and with collimating screws.

Fig. 89.

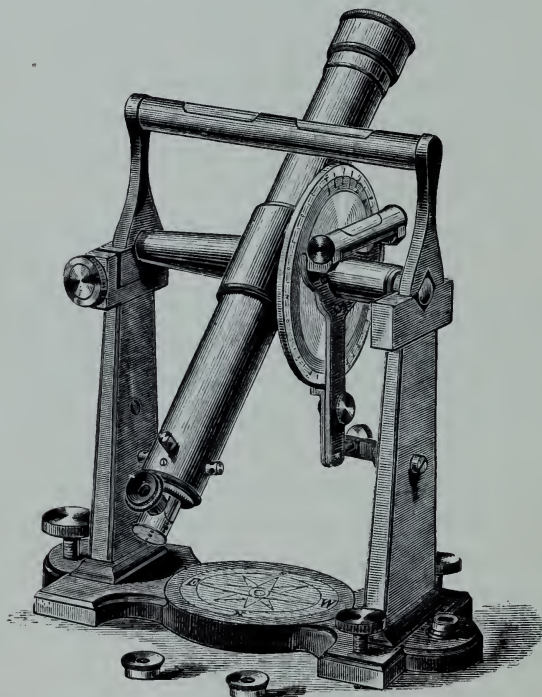

CHEAP TRANSIT INSTRUMENT DEVISED BY MR. LATIMER CLARK.

The accessories include a diagonal eye-piece, two dark glasses for observations of the sun, and a 7^{in} striding level of great delicacy. The optical power of the telescope is sufficient to show the larger stars and planets in full daylight. The illumination of the cross-wires at night is effected by a front reflecting diaphragm, and the instrument is provided with a candle lantern carried on an adjustable support. The ordinary

axial illumination (which is less effective) can be supplied if preferred. The whole instrument is mounted on a base of cast-iron provided with large gun-metal levelling screws.

The interior adjustments for collimation and focal distance are novel. A front diaphragm of contracted aperture enables a meridian mark to be sharply focussed at a distance of 40 yards or even less, which is often an important advantage.

An especial convenience of this instrument consists in the means by which the altitude circle is set and adjusted, and the telescope maintained steady in position while the observation is being taken. This is effected by a tail-piece attached to the vernier circle by a clamping screw which rests against a stop on the uprights or the base plate, with a fine adjusting screw. By this means the star may be brought on to the horizontal wire, and the telescope held firmly in position so as not to be liable to disturbance by a blow from the rim of the observer's hat or other cause. Moreover the use of the small level is dispensed with, and the adjustments can be all made indoors, so that the observer has nothing to do out of doors but to place the instrument in position on its out-door stand, which done, it is quite ready for immediate use. The stand is attached to its base by a screw acting on an elastic plate which gives remarkable firmness and steadiness. A larger size is also made with an 18ⁱⁿ telescope, 10½ⁱⁿ axis, and an aperture of 1¾ⁱⁿ.

Fig. 90 is an instrument specially designed for fixing on a window-sill, but it is at the same time equally adapted for use on a wall or pillar. For practical use it may be considered identical with the 13ⁱⁿ Transit represented in Fig. 89, the focal length, aperture and optical power being the same. It is, however, totally different in appearance, owing to the fact that the diagonal eye-piece is dispensed with, and the prism is increased in size and placed in the axis, which is at this point enlarged, the telescope being bent at right angles. Everything in fact has been done to concentrate the parts of the instrument and diminish its size. It packs into a much smaller compass than any other form, and the base, which is circular, is only

$6\frac{1}{2}$ in diameter and 3 in height, so that when covered with a flat zinc cap it is so small as to be scarcely noticeable. It is therefore peculiarly adapted for window use, and is without

Fig. 90.

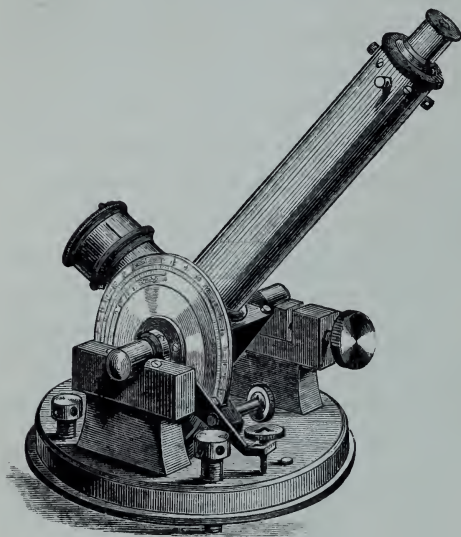

CLARK'S WINDOW TRANSIT.

doubt the most convenient instrument for all ordinary purposes of obtaining time. Its collimation is not so easily effected as in the case of the ordinary form, and can only be tested by a suitable collimator or by the Pole Star; but as the collimation is carefully adjusted and tested by the maker, and as it is not in the least liable to derangement, this strong and compact instrument is well adapted for popular

purposes. Owing to the great reduction in its size and weight, the cost is less than that of the other form. It has the same adjustments for level and altitude, and the illumination may be effected by an ordinary bull's-eye lantern.

Fig. 92 is an illustration of a species of Transit Instrument^s for obtaining true time, constructed specially for the use of chronometer, clock, and watch-makers in the rating of clocks or any kind of time-keeper. It is small and compact in size; and is easily fitted up in a workshop, or other convenient place. It is intended for taking a simple and expeditious observation of the Sun at noon, by which means true time may of course be arrived at independently of time signals, or electric time wires. Though intended specially for observations of the Sun,

^s Made by J. Short, 2 Gladstone Street, Southwark, London.

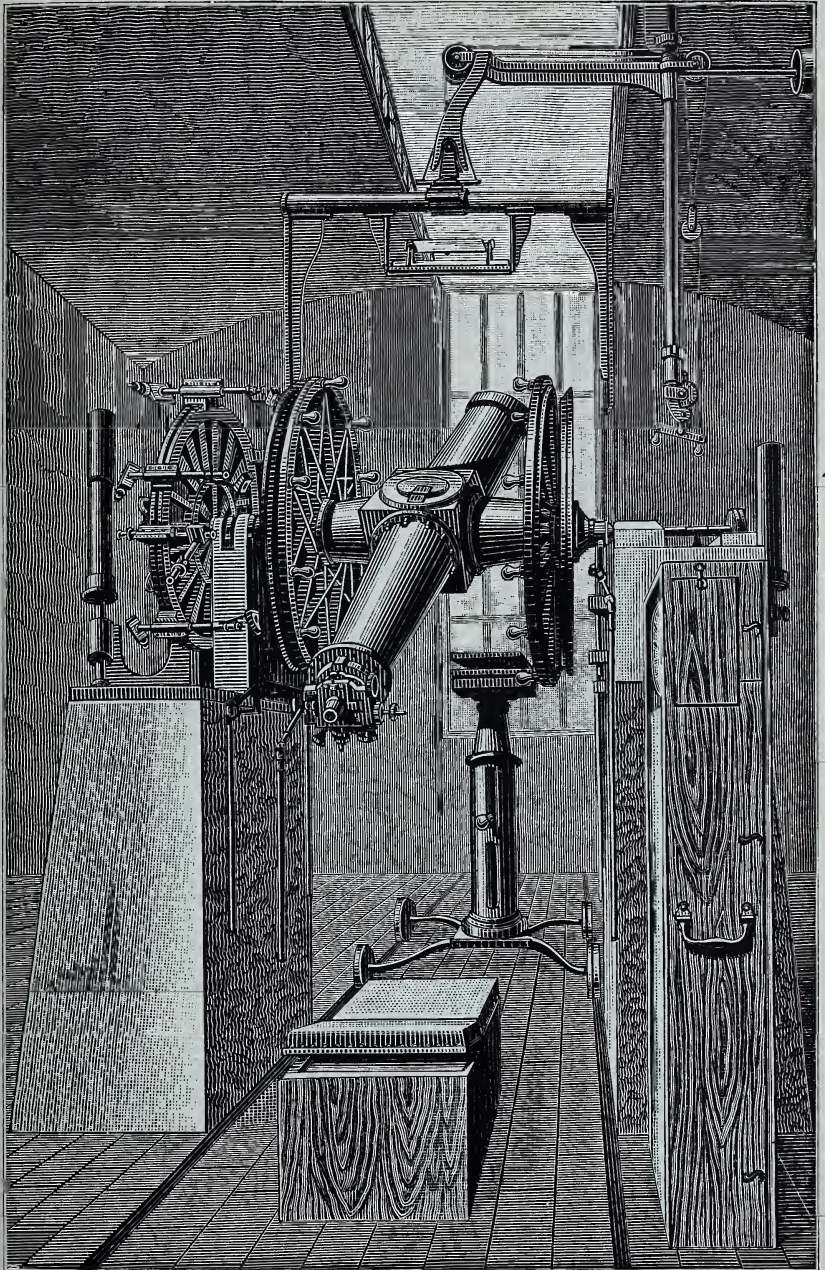

THE MERIDIAN CIRCLE OF THE PARIS OBSERVATORY.

it can be used for observing stars also, if desired. It has a base-plate which can be fitted on a window-sill, or other such place, so that the instrument can be removed when not wanted, and replaced by fixing a hand-screw, which done, it is in adjustment for *immediate* use. The instrument therefore need not be exposed to the weather if used out of doors, nor does it stand fixed in the way of other things if used indoors.

It is altogether beyond the scope of this volume to deal with the "Transit Circles" used in large and well-equipped public and private observatories. Of these the Greenwich Circle is one of the most important and best known, the more so as it has served as the model for others, but Circles comparable with it will be found in many other observatories, British and Foreign: notably at Paris, Strassburg, Vienna, and Washington[†].

Fig. 91, Plate XXIII. represents the Meridian Circle presented by a well-known liberal patron of astronomy in France, M. Bischoffsheim, to the Observatory of Paris. Of course in principle it does not differ from the ordinary transit instrument, but it is furnished with many more accessories. The diameter of the object glass is $7\frac{1}{2}$ in, and the focal length $7^{\text{ft}} 7^{\text{in}}$.

Fig. 93 represents the small and old-fashioned Transit Circle made by Troughton as far back as 1793 and now the property of the Royal Astronomical Society, and known as the "Lee"

Fig. 92.

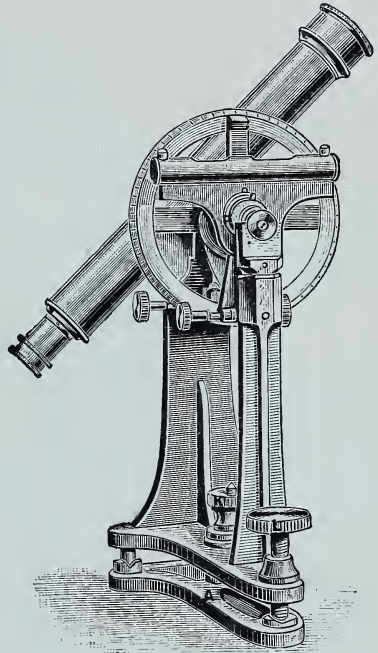

SHORT'S RATING INSTRUMENT.

[†] The Germans usually call these Instruments Meridian Circles (*Meridienkreise*).

Circle, from the name of the donor, Dr. John Lee of Hartwell, a munificent patron of astronomy in his day. The diameter

Fig. 93.

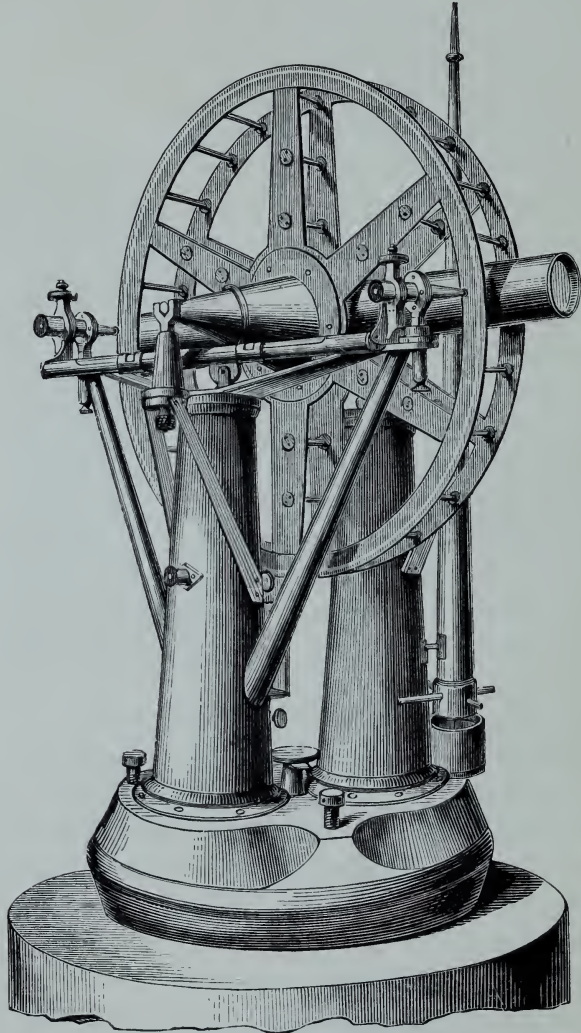

THE "LEE" CIRCLE.

of the circle is 2^{ft}, and the focal length of the telescope 2^{ft} 6ⁱⁿ.

CHAPTER V.

THE SEXTANT.

Description of the instrument.—The optical principle on which it depends.—Its adjustments.—Corrections to be applied to observations made with it.—Method of finding the Sun's zenith distance.—The artificial horizon.—To find the latitude.—To determine the time.

THE Sextant^a, sometimes called, from its inventor, "Hadley's Sextant," is a graduated arc of a circle, with certain accessories, so arranged that it can be employed to measure angular distances, especially of celestial objects. It is an instrument of great practical importance to the navigator and traveller for determining the time, the latitude, and the longitude. Though less directly an astronomer's instrument than those which we have hitherto considered, it is often valuable for purposes strictly astronomical—such as ascertaining the time, and fixing the positions of comets, from which Right Ascensions and Declinations can be derived.

Fig. 94 is a representation of the sextant in its usual form. Its flat surface is called the *plane of the instrument*: eh is the arc or *limb*, reading, by the vernier attached to the moveable radius $a g$, to $30''$, $20''$, $15''$, or $10''$ (and, rarely, to $5''$), as the case may

^a Sir J. Herschel, *Outlines of Ast.*, p. 115; *Phil. Trans.*, vol. xxxvii. p. 147, 1731; Pearson, *Pract. Ast.*, vol. ii. p. 572; *Nautical Magazine*, vol. i. p. 351; *English Cyclopædia*, art. *Sextant*; Loomis, *Pract. Ast.*, p. 96; Galbraith and Haughton, *Optics*, p. 63; Heather, *Math. Instr.*, p. 137; Simms, *Treat. on Instr.*,

p. 49; Young, *Nautical Astronomy*, p. 172; Narrien, *Ast. and Geod.*, p. 98; Challis, *Lectures on Pract. Ast.*, p. 356; Wilberforce, *The Sextant*; C. W. Thompson, *Manual of the Sextant*. As to the invention of the sextant, see a paper by Dreyer in *Ast. Nach.*, vol. cxv. No. 2739, July 28, 1886.

be: *a* is the silvered *index-glass*, provided with screws for its adjustment. At *b* are the *fore-shades*, or screens of coloured glass: *c* is the *horizon-glass*, the lower half of which is silvered, and which also has screws for its adjustment. At *d* are the *back-shades* or screens, also of coloured glass: *i* is the telescope—an accessory which is not in theory an essential feature of the instrument: *ag* is the moveable radius, carrying at one end the index-glass and at the other a vernier, which is read by a microscope, or its equivalent. Slow motion is imparted to the radius by a tangent screw, *f*.

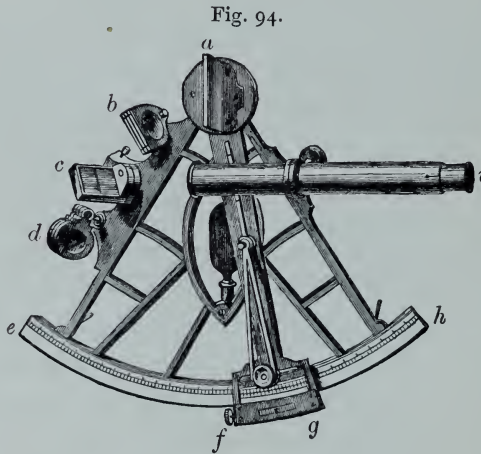

THE SEXTANT.

The principle of the sextant depends on the practical application of the following theorem in optics: *When a ray of light, proceeding in a plane at right-angles to each of 2 plane mirrors which are inclined to each other at any angle whatever, is successively reflected at the plane surfaces of each of the mirrors, the total deviation of the ray is double the angle of inclination of the mirrors.*

The adjustments of the sextant are 5 in number. It is necessary—

1. That the *index-glass* should be perpendicular to the plane of the instrument.
2. That the *horizon-glass* should be perpendicular to the plane of the instrument.

3. *That the horizon-glass should be parallel to the index-glass when the zero of the vernier coincides with the zero of the arc.*

4. *That the line of collimation, or the optical axis of the telescope, be parallel to the plane of the sextant.*

5. *That the index error be known.*

These several adjustments will now be described^b, as occasionally it is useful for amateur astronomers to know how to wield a sextant.

1st adjustment. *To determine whether the index-glass is perpendicular to the plane of the instrument.*

Bring the vernier to the middle of the arc, and, with the limb turned away from you, look obliquely into the mirror; then if the reflected and true arcs appear as one continued arc of a circle, the index-glass is in adjustment—*i.e.* is perpendicular to the plane of the instrument. If the index-glass is not in adjustment, the screwdriver must (but with great care) in this and other cases be called into use.

2nd adjustment. *To determine whether the horizon-glass is perpendicular to the plane of the instrument.*

With the zero of the vernier coinciding with the zero of the arc, hold the sextant *horizontally*, and, looking at the horizon, observe if the reflected and real horizons appear as one continuous or unbroken line: or, otherwise, hold the instrument perpendicularly, and look at any convenient object, such as the Sun; sweep the index-glass along the limb, and if the reflected image pass exactly over the direct image without any lateral projection, the horizon-glass is perpendicular to the plane of the instrument.

3rd adjustment. *To determine whether the horizon-glass is parallel to the index-glass when the zero of the vernier coincides with the zero of the arc.*

Hold the instrument in a *vertical* position, and through the telescope look towards the horizon, and observe if the reflected and real horizons form one continuous or unbroken line; if they do, the horizon-glass is parallel to the index-glass.

^b Rosser's *Navigation*, p. 197.

4th adjustment. *To make the line of collimation parallel to the plane of the instrument.*

Fix the telescope in its place, taking care that 2 wires are parallel to the plane of the instrument; select 2 objects (such as the Sun and the Moon, or the Moon and a bright star) more than 90° distant from each other, and bring them into contact on the wire nearest the instrument. Then slightly move the sextant, and see how they appear on the other wire. If they are still in contact, the line of collimation is in adjustment: but if the objects separate when brought to the farther wire, the object-glass end of the telescope *inclines towards* the plane of the sextant; if one overlies the other, the object-glass end of the telescope *declines from* the plane. The adjustment is made by tightening one and loosening the other of the 2 screws in the collar holding the telescope.

5th adjustment. *To determine the index error.*

Measure the Sun's diameter on the arc of the instrument and on the arc of excess, which is done by holding the sextant perpendicularly and bringing the real and reflected Suns in exact contact on each side of zero. *Half the difference of the 2 readings* will be the index error—which is additive when the reading on the arc of excess is the *greater*, but subtractive when the reading on the arc is the *lesser* of the 2.

To test the accuracy of these readings *off and on*, as they are called, add them together and divide the sum by 4. The quotient thus obtained should agree (approximately) with the semi-diameter of the Sun given in the *Nautical Almanac* for the day of observation. If there is a considerable discrepancy, the readings are erroneous.

Suppose that on Jan. 1, 1890, the following readings were taken—

Reading off	+ 34 °	0	34 °	0
Reading on	- 31	30	31	30
		2) 2 30		4) 65 30
∴ Index error	+ 1	15	☉'s semi-diameter	16 22

Presuming that his sextant is in adjustment, and its index error known, and that the altitude of some celestial object has

been taken, the observer must apply several corrections before he can arrive at the true altitude of the centre of the object viewed. If the object be the Sun or the Moon, these corrections are 4 in number; if the object be a fixed star, they are only 2. In the former case the corrections are for dip, refraction, semi-diameter, and parallax; in the latter, for dip and refraction.

1. *Dip.* The correction for dip is *subtractive*, for when observations are made from the deck of a ship the sea-horizon dips, or is depressed, below the level of the sensible horizon, and makes the observed altitude to be greater than the true apparent altitude.

The following is a table of this correction:—

Height.	Dip.	Height.	Dip.	Height.	Dip.	Height.	Dip.	Height.	Dip.
ft.	' "	ft.	' "	ft.	' "	ft.	' "	ft.	' "
1	0 59	10	3 3	19	4 13	28	5 2	65	7 48
2	1 22	11	3 12	20	4 20	29	5 13	70	8 6
3	1 40	12	3 21	21	4 26	30	5 18	75	8 23
4	1 56	13	3 29	22	4 32	35	5 43	80	8 39
5	2 10	14	3 37	23	4 39	40	6 7	85	8 55
6	2 21	15	3 45	24	4 45	45	6 29	90	9 11
7	2 33	16	3 52	25	4 51	50	6 51	95	9 26
8	2 43	17	3 59	26	4 56	55	7 11	100	9 41
9	2 54	18	4 6	27	5 2	60	7 30	110	10 9

2. *Refraction.* The correction for refraction is also *subtractive*. For an account of this phenomenon, see vol. i., Book III., *ante*; and for Tables, see Book XIII., *post*.

3. *Semi-diameter.* The Sun, Moon, and important planets have large discs; consequently only the limbs are observed, and in practice the lower limb by preference. To obtain the altitude of the centre we must *add* the semi-diameter to the altitude of the *lower* limb, or *subtract* it from the altitude of the *upper*. The semi-diameters of the Sun, Moon, and principal planets are given in the *Nautical Almanac* for each day of the year.

4. *Parallax.* The correction for parallax is *additive*, for in the

case of the Sun, Moon, and planets, the altitude taken on the Earth's surface is less than what it would be if our observations were made at the same moment, at the Earth's centre, and the altitude were measured from the rational horizon; and this difference between the apparent and the geocentric place of a celestial body is its parallax in altitude. When the body is in the horizon the parallax (then called the *horizontal parallax*) is greatest: in the zenith it vanishes altogether. The fixed stars, owing to their great distance, have no horizontal parallax: that of the Sun is about $9''$; that of the Moon is not only a large, but it is also a variable quantity, varying between the limits of about $61\frac{1}{2}'$ and $54'$; that of Mars may amount to $24''$; and that of Jupiter to $2''$.

The following is a table of the Sun's parallax in altitude:—

Alt.	0	12	15	30	33	39	42	48	51	57	60	66	69	72	75	78	81	84	90
Par.	9	9	8	8	7	7	6	6	5	5	4	4	3	3	2	2	1	1	0

The horizontal parallax of the Moon will be found in the *Nautical Almanac*.

The following is a summary of the corrections to be applied to an observed altitude of the Sun:—

1. *Index error*; + or -.
2. *Dip*; always -.
3. *Refraction*; always -.
4. *Semi-diameter*; + or -.
5. *Parallax*; always +.

FROM THE OBSERVED ALTITUDE OF THE SUN TO FIND THE
SUN'S ZENITH DISTANCE.

- I. *Apply the corrections needful for obtaining the true altitude.*
- II. *Subtract the true altitude from 90° , and the remainder is the zenith distance.*

EXAMPLE.—Jan. 1, 1867. Given, the observed altitude of the Sun's lower limb, $40^{\circ} 20' 30''$; index error, $2' 50''$ subtractive; height of eye, 18^{ft} . To find the true altitude, and thence the zenith distance of the Sun's centre.

I.

+ Corrections.	- Corrections.
Parallax + 0 7	Index error - 2 50
Semi-diameter ... + 16 18	Dip - 4 6
+ 16 25	Refraction - 1 8
- 8 4	- 8 4
+ 8 21	
Sun's observed altitude 40 20 30	
Corrections + 8 21	
Sun's true altitude 40 28 51	

II.

Sun's true altitude	0 0 0
	90
	40 28 51
∴ Sun's zenith distance	49 31 9

. When the Sun is N. of the observer the zenith distance is S., and *vice versa*.

The procedure in dealing with the Moon a large planet, or a star, is, *mutatis mutandis*, according to what has already been stated, the same.

A word about the "artificial horizon." This is a mere rectangular platform, of an area of 20 or 30 square inches, with raised sides and supported (sometimes) on 4 feet, two of them provided with coarse adjusting-screws for levelling.

Over the whole fits a case, with a sloping roof covered with sheet glass (the two surfaces of which must be absolutely

Fig. 95.

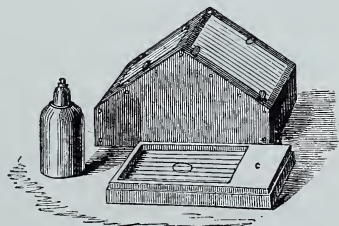

THE ARTIFICIAL HORIZON.

parallel), to protect from wind the platform, on which is poured out the quicksilver which forms the horizon ^c.

When an artificial horizon is used, the *dip* does not affect the observed altitude of a heavenly body, but the angle read off is the *double* of the actual angle of altitude.

Therefore —

TO OBTAIN THE TRUE ALTITUDE OF A HEAVENLY BODY FROM OBSERVATIONS WITH AN ARTIFICIAL HORIZON.

- I. *To the observed angle apply the index error.*
- II. *Divide the sum or the remainder by 2, and the quotient will be the apparent altitude.*
- III. *Then apply the several corrections for refraction, semi-diameter and parallax, as the case may require.*

It seems needless to offer an example of so simple a rule.

TO FIND THE LATITUDE.

This is both an astronomer's and a navigator's problem, and each uses ^d a method which is not naturally open to the other. The astronomer, in a fixed observatory, employs a fixed instrument (the Transit ^e) and an artificial horizon; the navigator, always in motion, employs a portable instrument (the sextant) and the natural horizon. But an astronomer may work with a sextant: therefore I shall give a simple sextant method which is also available for travellers in foreign climes.

The observations for altitude of a circumpolar star at its upper and lower transits furnish the best (and at the same time the simplest) method of determining the latitude, because the observer is independent of uncertainty in the value of the star's

^c Challis, *Lectures on Pract. Ast.*, p. 362. See also Capt. Shadwell's *Notes on the Management of Chronometers*, 2nd ed. p. 45, for much useful information.

^d Or 'generally finds it convenient to use,' for there are various methods possible.

^e Bessel suggested as an expedient of high astronomical value the observation of stars by means of a Transit Instrument

set up in the "Prime Vertical," or pointing E. and W. instead of N. and S., and an Instrument to carry out this suggestion was erected many years ago at the Pulkova Observatory under the superintendence of W. Struve. (*Ast. Nach.*, vol. xx. No. 468, Feb. 2, 1843; F. G. W. Struve, *Description de l'Observatoire de Pulkova*, p. 167; Challis, *Lectures on Pract. Ast.*, p. 333.)

Declination, and, to some extent, is independent of refraction also.

The first and most delicate stage in the operation is to obtain a zero point from which to measure the angular distance of the star. There are three zero points available, any one of which may be employed according to the taste of the observer; viz. the zenith, its correlative the nadir, and the horizon: the first two are in practice derived from the vertical floating collimator, and the third indifferently from the horizontal floating collimator or the artificial horizon. On the whole, the amateur astronomer working with a Transit Instrument will find it most convenient to use the artificial horizon, but the other instruments named will be alluded to hereafter. (See *post*.)

A traveller's method of determining the latitude is the following:—

- I. *Find the true zenith distance of the Sun's centre* [as in the process on p. 153].
- II. *Convert the local apparent time into Greenwich apparent time* [the means of ascertaining local apparent time will be explained presently], using the Table *post*, Book XIII., to turn the longitude into time.
- III. *Correct the Sun's declination* [*Naut. Alm.*, p. I. of each month] *for the Greenwich apparent time by taking proportional parts of the diurnal change*^f.
- IV. *Under the zenith distance put the corrected declination, each with its proper name N. or S.*

. If both are N. or both S., add them together, and the sum is the latitude N. or S.

If one is N. and the other S., their difference is the lat., of the same name as the greater.

When the Decl. is 0° the zen. dist. is the lat.; of the same name as the zen. dist.

When the zen. dist. is 0, the Decl. is the lat.; of the same name as the Decl.

When the zen. dist. and the Decl. are equal, but one is N. and the other S., the lat. is 0° , and the observer is on the equator.

^f In navigation books will be found a brief table of logarithms for performing this operation with celerity.

We will now work out the foregoing rule, borrowing the materials which are to be found on p. 155.

I.			
The zenith distance of the Sun's centre is	...		° ' " N. 49 31 9
II.			
Local apparent time, Jan.	...		d. h. m. 1 2 45
Longitude, 77° 30' W.	...	+	5 10
Greenwich apparent time, Jan.	...		1 7 55
III.			
Sun's Declination, Jan. 1	...		° ' " S. 23 6 9
,, ,, Jan. 2	...		23 1 29
Daily change	...	-	4 40
∴ Change for 7 ^h 35 ^m = 1' 28".			
Sun's Declination, Jan. 1	...		° ' " S. 23 6 9
Change for 7 ^h 35 ^m	...	-	1 28
Declination corrected	...		23 4 41
IV.			
Zenith distance	...		° ' " N. 41 31 9
Declination corrected	...		23 4 41 S.
Latitude	...		18 26 28

Which latitude is N.

TO FIND THE TIME.

The following convenient method for determining the time is modified from a method given by Norie:—

1. Subtract the Sun's Declination from 90° when the latitude and Declination are of the same name, or add it to 90° when they are of contrary names, and the sum or remainder will be the Sun's polar distance.

2. Add together the Sun's altitude, the polar distance, and the latitude of the place of observation; take the difference between half their sum and the Sun's altitude, and note the remainder.

3. Then add together—

The co-secant of the polar distance.

The secant of the latitude.

The co-sine of the Half-sum.

The sine of the Remainder.

4. Half the sum of these logarithms gives the sine of half the hour angle expressed in arc. This angle when doubled and converted into time by Table III.

(Book XIII., *post*) gives the apparent time from the nearest noon; consequently if the observation be made in the morning, the time thus found must be taken from 24^h to obtain the apparent time from the preceding noon. On applying the equation of time, mean time is obtained, and hence the error of the watch may be found.

An example^g of the foregoing rule, with the several stages arranged in what will be found in practice the most convenient order, is here appended.

I.	
Date	October 1, 1866.
Name of place of observation... ..	Uckfield, Sussex.
Latitude (L)	50° 58' 0"
Longitude	24° 15' E.

II.		
	Observed Sextant Altitude of the Sun.	Observed times by Watch.
	° ' "	h. m. s.
	70 53	0 9 25
	70 38	0 14 32
	70 35	0 15 51.5
	70 31	0 17 6.5
	70 24	0 20 56
	70 16	0 23 41.5
Sums	6)423 17	1 41 32.5
Means	70 32 50"	0 16 55.4

III.	
Sun's Declination at Greenwich	3 12 7.4 S.
Correction for longitude (insignificant)	
Correction for time from noon +	16
Sun's true Declination at Uckfield	3 12 23.4 S.
	+ 90
Sun's polar distance	Δ93 12 23 4

IV.	
Instrumental altitude of the Sun's lower limb	70 32 50
∴ Semi-instrumental altitude	35 16 25
Sun's semi-diameter +	16 1.4
Correction for parallax +	7.5
Correction for refraction -	1 20.5
Sun's true altitude	35 31 13.4

^g This example is given merely to illustrate the rule. Altitudes near the meridian are not to be relied on for determining time. The best results are

to be obtained when the object is as near the prime vertical as possible, provided it be not too low (on account of the uncertainty of refraction).

V.

					°	'	"
Sun's true altitude	35	31	13.4
Sun's polar distance	93	12	23.4
Latitude of Uckfield	50	58	0
Sum	179	41	36.8
∴ Semi-sum P	89	50	48.4

VI.

					°	'	"
Semi-sum	89	50	48.4
Sun's true altitude	35	31	13.4
Remainder Q	54	19	35

VII.

					°	'	"
Log. cosec. (compl.) Δ	(86 47 36.6)	0.0006806		
Log. sec. L	(50 58 0)	0.2008164		
Log. cos. P	(89 50 48.4)	7.4271974		
Log. sin. Q	(54 19 35)	9.9097443		
							2)17.5384387
				Sine of $\frac{1}{2}$ hour angle	8.7692194		
					°	'	"
∴ Half the hour angle	3 22 11					
∴ Hour angle (in arc)	6 44 22					
		h. m. s.					
∴ Hour angle (in time)	0 26 57.5					

VIII.

					h.	m.	s.
Apparent solar time	0	26	57.5
					12	0	0
Apparent civil time	12	26	57.5
Equation of time	-	10	19.5
Mean time at Uckfield	12	16	38.0
„ „ by watch...	12	16	55.4
Error of watch	+		17.4

In competent hands the sextant will generally give a result correct to within a few seconds. Even a Box Sextant used by Mr. F. Brodie on a voyage to the Cape of Good Hope in 1877 indicated the ship's position within 3 or 4 miles of the results found by the Naval Officers with their large sextants; and the latitude to within $\frac{1}{2}$ a mile.

The following method of adjusting the sextant has been proposed by Professor Comstock, who considers the ordinary method given above to yield results less precise than is often desirable.

Let the sextant be placed upon a table, or other firm and level support, and let an auxiliary mirror be placed approximately perpendicular to the sextant telescope at a distance of from 10^{ft} to 20^{ft} from it.

The first step in the adjustment is to make this mirror perpendicular to the plane of the sextant. Prepare two sights by fastening threads across circular apertures in 2 pieces of cardboard: one sight to be of two threads crossing each other at right angles; the other sight to be of one thread crossing the aperture at its diameter. These pieces of cardboard must be so fastened to wooden or metallic bases that when placed in an upright position on the arc of the sextant the centres of the apertures shall be nearly as possible on a level with the top of the silvered part of the horizon glass. Place these sights on the sextant arc as far apart as possible, and in such a position that by sighting through the apertures the image of the one nearest the auxiliary mirror may be seen reflected from it. Then holding the eye in the line determined by the cross threads, let an assistant turn the mirror until the image of the aperture in the front sight is bisected by the horizontal thread. This operation, as well as all the following ones, will be facilitated by throwing a beam of reflected sunlight upon the sextant. Interchange the sights and repeat the operation in order to eliminate any want of parallelism between the line of sight and the plane of the sextant. The mean of the two positions of the mirror thus found will be perpendicular to the plane of the sextant, and if the operations have been carefully performed the error of its position ought not to exceed 1' or 2'.

The adjustments of the sextant can now be very easily made by the use of this mirror.

I. *To adjust the index glass.* Tie a white thread around the middle of the index glass, and turn the glass until it is parallel to the mirror which has just been adjusted. If the index glass be

perpendicular to the plane of the sextant, a ray of light proceeding from the thread to the mirror will be reflected back to the index glass and then to the mirror again, &c., producing a series of images of the thread; and if the eye be held in the plane passing through the real thread and its first image, all succeeding images should be hidden behind the first one. If not so hidden, they will form a series upon one side of it and the index glass must be adjusted until the images coincide. It is evident that this is a very delicate test, and the accuracy of the adjustment is limited only by the accuracy with which the auxiliary mirror can be placed perpendicular to the plane of the sextant.

II. *To adjust the horizon glass.* This is best done by bringing into coincidence the images of a distant object seen directly and by reflection from the sextant mirrors. For an approximate adjustment the image of one of the sights seen in the auxiliary mirror may be used.

III. *To adjust the line of sight of the telescope.* Bring into the field of view the reflected image of one of the sights placed upon the arc of the sextant, and by turning the adjusting screws which secure the telescope collar in place, bring the image of the aperture in the sight midway between the cross threads of the telescope. In making this adjustment it will be well to use the eye-piece of highest power, and the threads in the field of the telescope must, of course, be placed approximately parallel to the plane of the sextant.

The angle which the line of sight of the telescope makes with a perpendicular to the horizon glass, called β by most writers, is one of the constants which enter into the theory of the sextant. Its value may be found to a sufficient degree of approximation in connection with these adjustments. Place one of the sights on the top or in front of the horizon glass, and turn the whole sextant about until the image of this sight reflected from the mirror is seen midway between the cross threads of the telescope, which must now be placed perpendicular to the plane of the sextant. Set the index glass approximately parallel to the

auxiliary mirror, and place against the front of the glass a piece of paper folded so as to present a sharply defined vertical edge. A series of images of this paper will be formed in the mirror. Let the eye be placed in the plane passing through the edge of the paper and its first image, and turn the index glass until the other images in the mirror are just hidden behind the first. The reading of the vernier corrected for index error equals 2β , as may be seen by constructing a figure representing the position of the index and horizon glasses, the auxiliary mirror and the line of sight of the telescope corresponding to the observation, and the position of the index glass when parallel to the horizon glass^h.

The *Box Sextant*ⁱ is merely a miniature sextant, very portable, and used rather for surveying than astronomical purposes, though, in conjunction with an artificial horizon, it becomes valuable for obtaining solar time, or the latitude.

The *Prismatic Sextant*, formerly constructed by the extinct firm of Pistor and Martins of Berlin, differs from the common sextant, not only in its construction but in its capability, for it can measure angles up to 180° .^k

^h *Sid. Mess.*, vol. vii. p. 129, Ap. 1888.

ⁱ Formerly the *Snuff-box Sextant*, from

the limited space it occupies *in transitu*.

^k Loomis, *Pract. Ast.*, p. 101.

CHAPTER VI.

MISCELLANEOUS ASTRONOMICAL INSTRUMENTS.

The Altazimuth.—Everest's Theodolite.—The Mural Circle.—The Repeating Circle.—Troughton's Reflecting Circle.—The Dip-Sector.—The Zenith-Sector.—The American Zenith-Sector.—The Reflex Zenith-Tube.—The Horizontal Floating Collimator.—The Vertical Floating Collimator.—The Heliometer.—Airy's Orbit-Sweeper.—The Comet-Seeker.—The Astronomical Spectroscope.

THOUGH the Transit Instrument and the Equatorial are the most important instruments used in astronomy, there are several others of an astronomical or semi-astronomical character, which should at least be glanced at in a work like the present. Still, as they are but rarely required by the amateur, my mention of them will be rather for the purpose of furnishing references to other works professedly devoted to their consideration than to treat of them at any length myself.

The following are the names of those instruments which I group under this head:—

1. The Altazimuth.
2. Everest's Theodolite.
3. The Mural Circle.
4. The Repeating Circle.
5. Troughton's Reflecting Circle.
6. The Dip-Sector.
7. The Zenith-Sector.
8. The Reflex Zenith-Tube.
9. The Horizontal Floating Collimator.

10. The Vertical Floating Collimator.
11. The Heliometer.
12. The Astro-photo-heliograph.
13. Airy's Orbit-Sweeper.
14. The Comet-Seeker.
15. The Siderostat.
16. The Astronomical Spectroscope.

The *Altazimuth*^a, as its name implies, is used for the measurement of altitudes and azimuths. It may be considered as a modification of the ordinary transit circle, the telescope, circle, and stand of which are capable of motion round a vertical axis. The altazimuth may therefore be used for meridional or extra-meridional observations indifferently, and when of a portable size it may in fact be regarded as a theodolite of a superior construction. The form of the instrument represented in Fig. 96 is sometimes known under the name of the *Transit Theodolite*^b.

Fig. 97 is a pattern of a theodolite, known as "Everest's," from its designer, the late Sir G. Everest, Director of the Indian Survey. The arrangement adopted for the graduated arcs enables the observer, it is understood, to measure minute angles with greater accuracy than is possible with an ordinary theodolite of corresponding size; and for geodetical purposes, especially in foreign countries, a maximum of precision with a minimum of weight is of course a matter of the utmost importance. This instrument can be used within certain limits of altitude as an altazimuth^c.

The *Mural Circle* consists of a graduated circle furnished with a suitable telescope, and very firmly affixed to a wall (*murus*)

^a Pearson, *Pract. Ast.*, vol. ii. pp. 413, 457, 472; Heather, *Mathematical Instruments*, p. 153; Simms, *Treatise on Instruments*, p. 92; *English Cyclopaedia*, art. *Astronomical Circle*; Loomis, *Pract. Ast.*, p. 93; Narrien, *Ast. and Geod.*, p. 79; Challis, *Lectures on Pract. Ast.*, pp. 317 and 338. The most perfect and at the same time best known altazimuth is that erected at Greenwich in 1847, for an account of which see the *Introduction*

to the *Greenwich Observations*, 1847, p. iv. It was for this particular instrument that the name "altazimuth" was invented, the same class of instrument having previously borne the compound name of "altitude-and-azimuth instrument."

^b Challis, *Lectures on Pract. Ast.*, p. 344.

^c Simms, *Treatise on Instruments*, p. 20.

in the plane of the meridian. This instrument^d, which was introduced for determining with great accuracy meridian altitudes

Fig. 96.

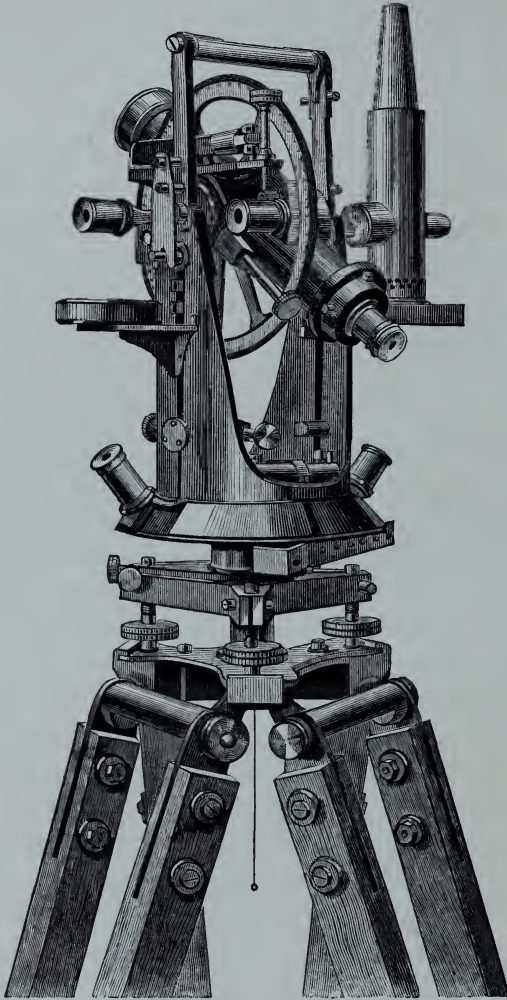

THE PORTABLE ALTAZIMUTH, OR TRANSIT THEODOLITE.

and zenith distances, may now be regarded as obsolete, having been superseded by the Transit Circle.

^d Pearson, *Pract. Ast.*, vol. ii. p. 472; Breen, *Pract. Ast.*, p. 432; Narrien, *English Cyclopædia*, art. *Astronomical Circle*; Loomis, *Pract. Ast.*, p. 83; Challis, *Lectures on Pract. Ast.*, p. 148.

The *Repeating Circle* is employed for the measurement of angular distances, both of celestial and terrestrial objects. The principle consists in repeating the readings of an angle several successive times and taking a mean, and thus eliminating almost

Fig. 97.

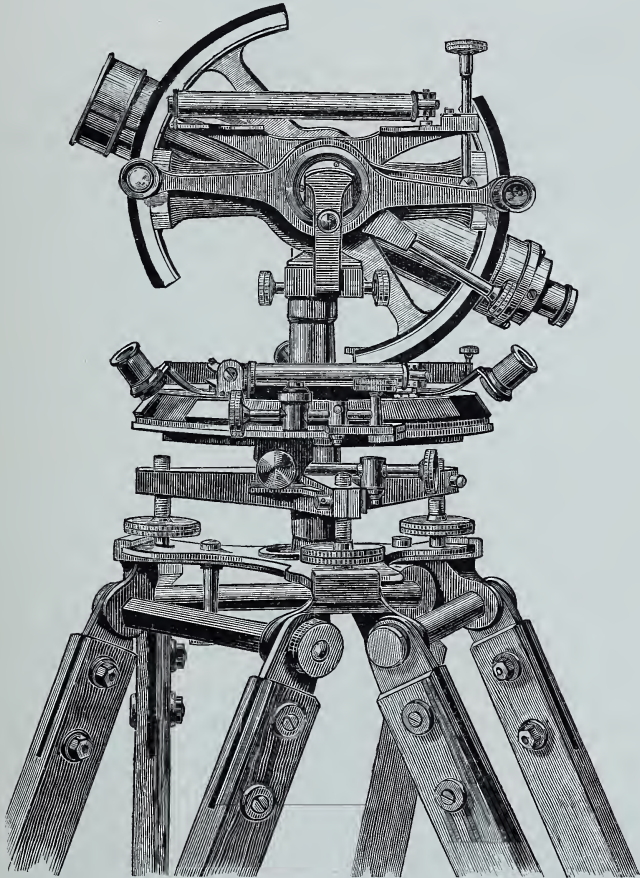

EVEREST'S THEODOLITE.

wholly the errors due to defective graduation. Invented about the year 1744 by T. Mayer, this instrument was first constructed in France, under the superintendence of Borda, some time between 1780 and 1790, and in that country it was much used. In England, however, it was never popular, firstly, because

when it was invented the graduation of English instruments was so much superior to those of foreign make as to render it less needed; and secondly, because of the labour involved in working with it. Its value (theoretically very considerable) would seem to be impaired in practice by some defects which Sir J. Herschel, though he spoke of them as unknown, connected with imperfect clamping^e.

Troughton's Reflecting Circle is a different adaptation of the principle involved in the sextant. It consists of a complete graduated circle, having the telescope and reflector on one side of the circle whilst the graduations and verniers (3 in number) are on the other. A reading being taken by each vernier, the mean of the three readings gives a more accurate result than would any one singly. In Sir J. Herschel's opinion "this is altogether a very refined and elegant instrument^f."

The *Dip-Sector*, another instrument of Troughton's invention, is used for determining the dip of the horizon. The principle of it is similar to that of the sextant^g.

The *Zenith-Sector* serves to determine with great accuracy the zenith distances of stars on the meridian. It is, especially as modified by Airy, chiefly used in geodetical operations; but it was invented by Hooke about the year 1669, to ascertain whether the Earth's orbit afforded any sensible parallax^h.

A form of zenith telescope used by the officers of the United States Coast Survey, and preferred by them to Airy's Zenith-Sector, is represented in Fig. 98. It was devised originally by

^e *Outlines of Ast.*, p. 119; Brewster's *Cyclopædia*, art. *Circle*; *English Cyclopædia*, art. *Repeating Circle*; *Memoirs R.A.S.*, vol. i. p. 33; Pearson, *Pract. Astron.*, vol. ii. p. 578; Loomis, *Pract. Astron.*, p. 103; Breen, *Pract. Astron.*, p. 381; Challis, *Lectures on Pract. Ast.*, p. 364.

^f Pearson, *Pract. Ast.*, vol. ii. p. 586; Simms, *Treat. on Instr.*, p. 57; Heather, *Math. Instr.*, p. 141; Challis, *Lectures on Pract. Ast.*, p. 363.

^g Simms, *Treat. on Instr.*, p. 65.

^h Pearson, *Pract. Ast.*, vol. ii. p. 531; *Month. Not.*, vol. v. p. 188, May 13, 1842; Narrien, *Ast. and Geod.*, p. 83; Challis, *Lectures on Pract. Ast.*, pp. 329, 337. A description of Pond's great zenith sector formerly in use at the Greenwich Observatory will be found in *Phil. Trans.*, vols. cxxiv. p. 209, cxxv. p. 145, 1834, 1835. Airy's form of the instrument is described in *Astronomical Observations made with Airy's Zenith Sector*, 4to. Lond. 1852; one of the Ordnance Survey volumes.

Captain Talcott to carry out practically the principle based upon the proposition that when the meridian zenith distances of

Fig. 98.

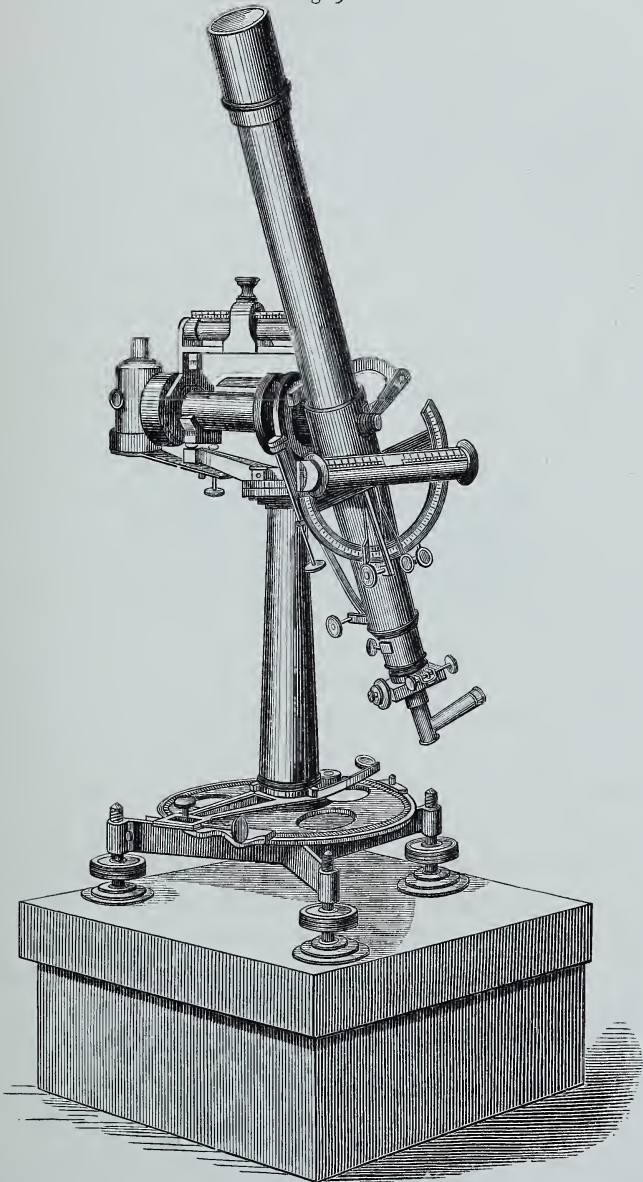

ZENITH TELESCOPE OF THE U. S. COAST SURVEY.

two stars at their upper culmination (one being N. and the other S. of the zenith) are equal, the colatitude is the mean of their N.P.D.'s. It is therefore necessary, to avoid arc readings, that the telescope when pointed to any zenith distance should be capable of revolution on a vertical axis. And as two stars could rarely be found having the same meridional zenith distance, those are selected in pairs (N. and S.) which culminate within a few minutes of time and within $20'$ of arc of zenith distance of each other, and the difference of meridional zenith distance is measured by a micrometer, and change of verticality by a delicate level. Stops are clamped on the azimuth circle to denote when the instrument is in the meridian. The telescope is set to the nearest minute of the apparent mean zenith distance of the two stars; the star is bisected at culmination by the micrometer line, and the micrometer and level are read. Then the telescope is revolved through 180° and the second star observed in the same manner. The American officers allow 5 minutes between the 2 stars of every pair, and when the double observation is complete 7 minutes before another is commenced. Accuracy in the results depends on the delicacy of the level and of the micrometerⁱ.

The *Reflex Zenith-Tube* is used at Greenwich for observations of the star γ Draconis by reflection in a trough of mercury. It was invented by Airy^k.

The *Horizontal Floating Collimator* and the *Vertical Floating Collimator* are two instruments of similar principle, and of not very different construction, designed to facilitate the adjustment of circles. The former is used for determining the horizontal point, and the latter the zenith or the nadir points, as the case may be. Each kind consists of a telescope (with a system of cross wires in its field) which is either made to rest in a horizontal position on a plate of iron floating on a surface of mercury; or is fixed vertically in a frame, at the lower part of which is an iron ring the plane of which is at right-angles to

ⁱ *Month. Not.*, vol. xxviii. p. 181, April 1868; Chauvenet, *Pract. Ast.*, p. 350.

^k A full description of it is given in the *Greenwich Obs.*, 1854, App. I.

the axis of the telescope, the ring floating on mercury in an annular vessel. The telescope of the circle which it is desired to adjust being duly put in position, the observer looks through it, either downwards or upwards (as the case may be), to the telescope of the collimator, which in the vertical instrument is mounted with its axis coincident with the axis of the ring. The adjustment consists in bringing the cross wires of the two telescopes to a mutual intersection, by the screw movements of the circle. These instruments were both invented, or perhaps it would be more reasonable to say contrived, by Captain Kater, but the vertical one is that to which the preference is usually given¹.

Fig. 99.

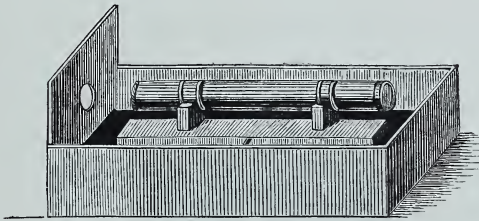

THE HORIZONTAL FLOATING COLLIMATOR.

Admiral Smyth made much use of Kater's Collimator, and his remarks may be incorporated here.

Fig. 99 represents the Horizontal Floating Collimator formerly employed at the Bedford Observatory.

It consisted of a small telescope laid in a horizontal position on a block of cast iron. This floated in a rectangular vessel filled with mercury, the under side of the iron block being well browned with nitric acid to prevent the adhesion of the mercury. The instrument was erected in the south wall of the Observatory and used as a fixed point for the collimation of the Transit Circle.

¹ *Phil. Trans.*, vol. cxv. p. 147, 1825; *Pract. Ast.* vol. ii. p. 446; Herschel, *Outlines of Ast.*, p. 107. *ibid.*, vol. cxviii. p. 257, 1828; *English Cyclopædia*, art. *Collimator*; Pearson,

Fig. 100 represents the Vertical Floating Collimator of the Bedford Observatory. It was mounted on 2 beams stretching

Fig. 100.

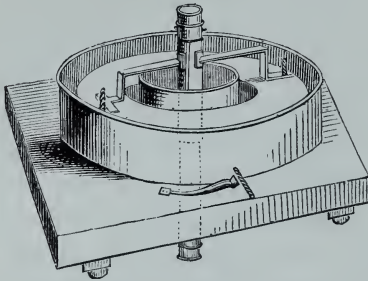

THE VERTICAL FLOATING COLLIMATOR.

across the Observatory immediately over the Transit Circle. In order to move it away from the zenith when an unimpeded zenith was required it was provided with 4 friction rollers sliding on a miniature iron railway.

From the sketch it will be seen that the instrument is a telescope having attached to it an annular iron float enclosed in a corresponding annular trough, where it swims upon a stratum of quicksilver. The trough is mounted on a mahogany frame with friction rollers at the 4 corners, as stated above. The telescope is carried clear through the whole apparatus and has certain spider lines arranged across its field. The theory of the instrument will be understood from Fig. 101.

The line cc' may be supposed to represent the visual ray from the observing instrument into space. The little circle aa' represents the path described by the centre of the diaphragm in the collimating telescope as the float is made to revolve through 180° in the annular trough; it cannot proceed beyond this point, being checked by a pin and an inclined spring. The optical axis of the floating telescope is here supposed to have an inclination represented (but purposely exaggerated) by ab in its first position, and by $a'b'$ in its second position, after having been turned right round in azimuth. The mean of the two, or $\frac{1}{2}$ the sum of the readings a and a' , of course constitutes the true zenith direction for cc' , from which the star e , measured on the arc dd' , will be duly corrected^m.

^m For more information both as to the theory and practice of the Floating Collimators see Kater's paper in *Phil. Trans.*,

vol. cxviii. p. 257, 1828; and Challis, *Lectures on Practical Astronomy*, p. 182.

Mention may here be made of Bohnenberger's "Collimating Eye-piece," an important auxiliary instrument which enables an observer to obtain instrumental corrections exclusively by optical means. It was invented by Bohnenberger of Tübingen about 1826, but as now made has undergone some variations of detailⁿ.

Fig. 101.

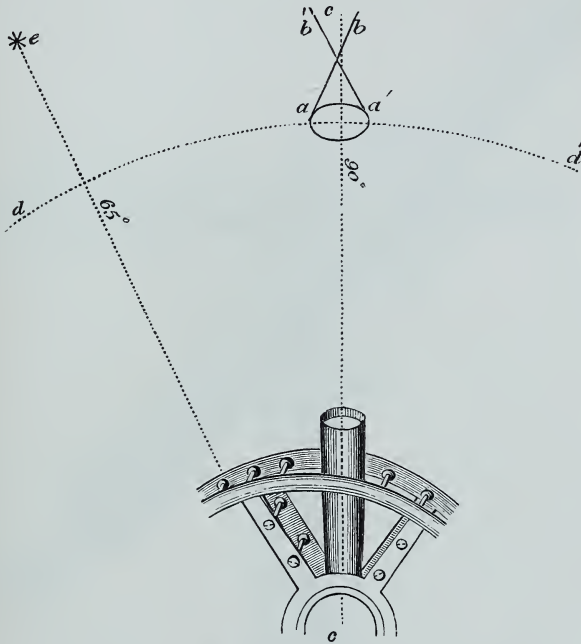

THEORY OF THE VERTICAL FLOATING COLLIMATOR.

An instrument of American origin called the *Almucantar* deserves a brief notice here. It is in its general nature an equal altitude instrument. A trough in the form of a hollow rectangle containing mercury revolves horizontally on an upright central pillar. The trough contains a float of similar form so arranged as to be perfectly free to seek equilibrium while it is constrained to revolve with the trough. This float carries the telescope, which turns on a horizontal axis and can be clamped at any

ⁿ *Ast. Nach.*, vol. iv. No. 89. For full particulars of this instrument as now made see Challis's *Lectures on Practical Astronomy*, p. 69.

desired altitude. Thus, as the instrument is revolved on its vertical axis any given point in the field of view describes a horizontal small circle, or almucantar, in the heavens; and the transits of stars over a series of horizontal lines will afford the

Fig. 102.



THE ALMUCANTAR.

means of determining by a proper distribution of the observations in azimuth the altitude of the instrument, the error of the clock, the latitude, or the Declinations of the stars. The inventor, Mr. S. C. Chandler, claims for this instrument that a higher degree of accuracy is attainable by it than by a Transit instrument

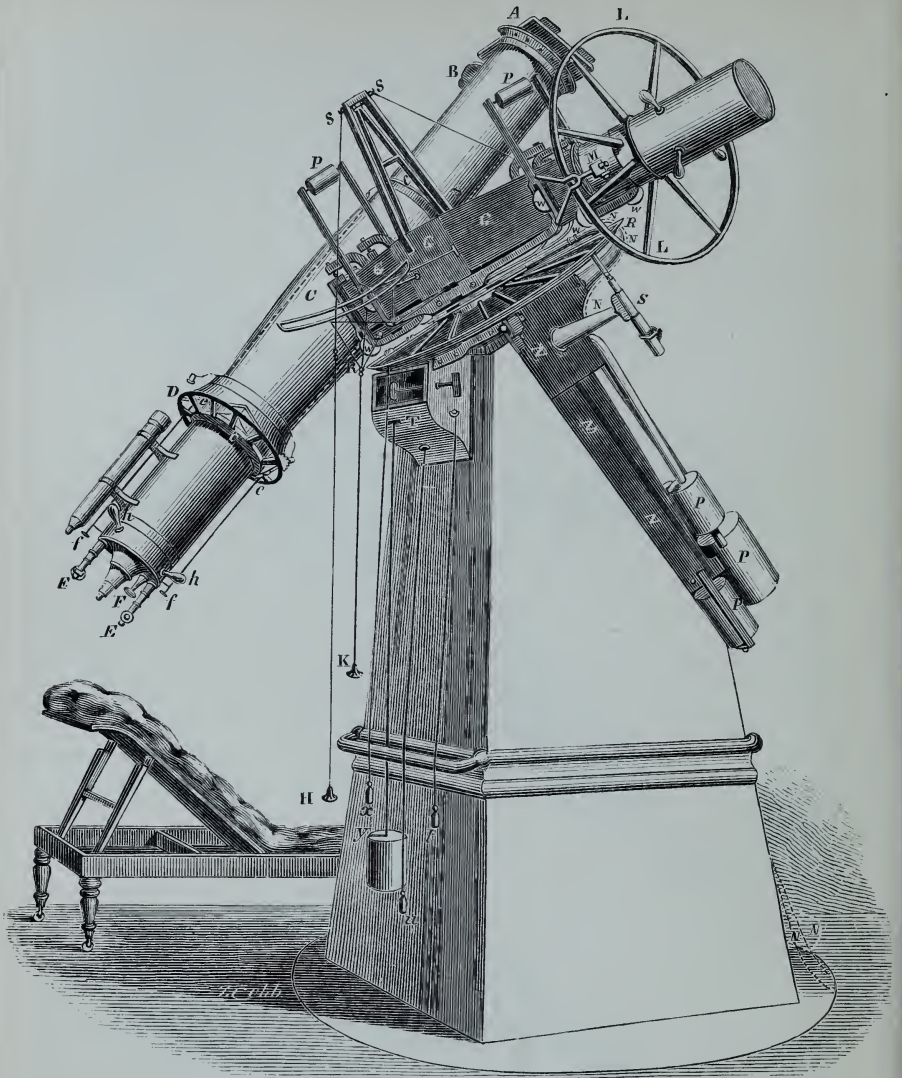

- A. Frame of the divided object-glass.
 B. Micrometer head of the external scale.
 C. Cradle bearing the tube, which is turned by the handles *hh*, on the collars *cc*.
 D. Position circle, whose slow motion depends on *ee*, while the clamp and tangent screws are *ff*.
 E. Microm. microscopes for reading off the interior scale at the object end, illuminated by galvanism.
 F. Rod for separating the object-glass.
 G. Iron box covering the declination axis.
 W.W. Friction rollers for relieving this axis.
 H. Declination slow-motion handle, and *ss* its screws.
 K. Rod for clamping the declination circle (the clamp is not seen).

- LL Declination circle.
 M. One of the reading microscopes of ditto; the instrument is roughly set by the wooden handles.
 N.N. Part of the course of the galvanic communication.
 P.P. Counterpoises for the declination and R.A. axes.
 R.R. Hour circle.
 S. One of its micrometer microscopes.
 T. Clock for carrying the instrument.
 t. Rod for setting the clock going.
 u. Rod for regulating its rate.
 x. Rod for connecting it with the hour circle.
 y. Clock weight.
 ZZZ. Box containing the polar axis.

or zenith telescope of the same size^o; and that it is useful not only for observations of time and latitude, but also in various higher and more delicate problems of practical astronomy, for the solution of which it furnishes a new method.

The *Heliometer*^p is a large telescope mounted equatorially in the usual way, but with its object-glass divided into two equal parts by a section across the centre. The parts of the object-glass are capable of motion in their own planes through considerable intervals, by means of screws, and thus their optical centres can be separated by a greater or less space. As each half-glass forms a separate image of any object, the two images will be at an angular distance dependent on the amount of the separation of the centres of the two half-glasses. By proper management the angular distances of two objects not very far apart can thus be determined^q.

The best known heliometer is that erected at the Radcliffe Observatory, Oxford, in 1850, the optical parts by Merz of Munich and the mounting by Repsold of Hamburg. The object-glass is $7\frac{1}{2}$ inches in diameter, with a focal length of 10 ft. 4 in. There is also another celebrated heliometer at Königsberg. As a working astronomical instrument the heliometer has not met with general favour, owing especially to its costliness in proportion to its optical power.

The *Astro-photo-heliograph* is in principle a simple equatorial, mounted with divers accessories to fit it for taking photographs of celestial objects. [Fig. 105, Plate XXV.]

Orbit-Sweeper is the name given by Airy to a contrivance

^o *Sidereal Messenger*, vol. ii. p. 269, Dec. 1833; *Proceedings Amer. Assoc. Adv. of Science*, Boston Meeting, 1880, *Proceedings*, part i. p. 152; *Annals of Harvard Coll. Obs.*, vol. xvii. p. 1.

^p ἥλιος the Sun, and μέτρον a measure; so called because the instrument was first used to measure the Sun. Being now employed for various other purposes the name is not an appropriate one. The elder Dollond called it the *divided object-glass micrometer*, and De Charmères (a French naval officer of the last century,

who has some claim to be regarded as its inventor) a *megameter*, in opposition to *micrometer*.

^q *Radcliffe Observations*, vol. xi.; *Speculum Hartwellianum*, p. 156; Weale, *London*, p. 677. A somewhat full account of the heliometer, with a good engraving of the celebrated heliometer at Königsberg used by Bessel, will be found in *L'Astronomie*, vol. iii. p. 343, Sept. 1884; and see *Dun Echt Observations*, vol. ii. p. 1; *Encycl. Brit.*, art. "Micrometer."

which he thinks meets an acknowledged difficulty. A comet or planet is known by previous calculation to be pursuing a certain and tolerably definite track through the heavens, but its actual position at any given time is unknown. To sweep for such an object an unmounted telescope is of little or no use, and an equatorial is hardly more suitable, unless the path of the object be continuously through the same parallel of Declination Eastwards and Westwards, or through the same hour of Right

Fig. 104.

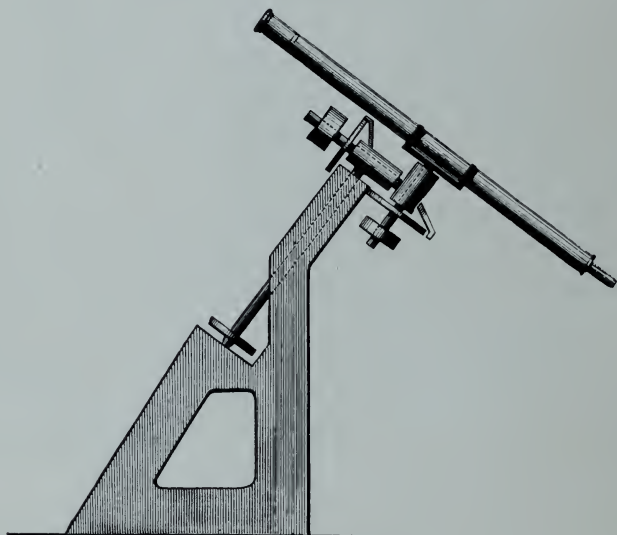

AIRY'S ORBIT-SWEEPER.

Ascension, Northwards and Southwards—a condition which it is scarcely necessary to mention never subsists, unless it be for a very limited period of time, the apparent course of planets and comets being almost always *inclined*.

It is to follow by one motion this inclined path that Airy's new instrument is designed. It resembles a German equatorial the polar axis of which is of a greater length than usual, and which works for some distance at its upper end in a tubular bearing. The declination, or cross, axis, carries at one end a counterpoise, and at the other, not, as in the regular equatorial, the telescope,

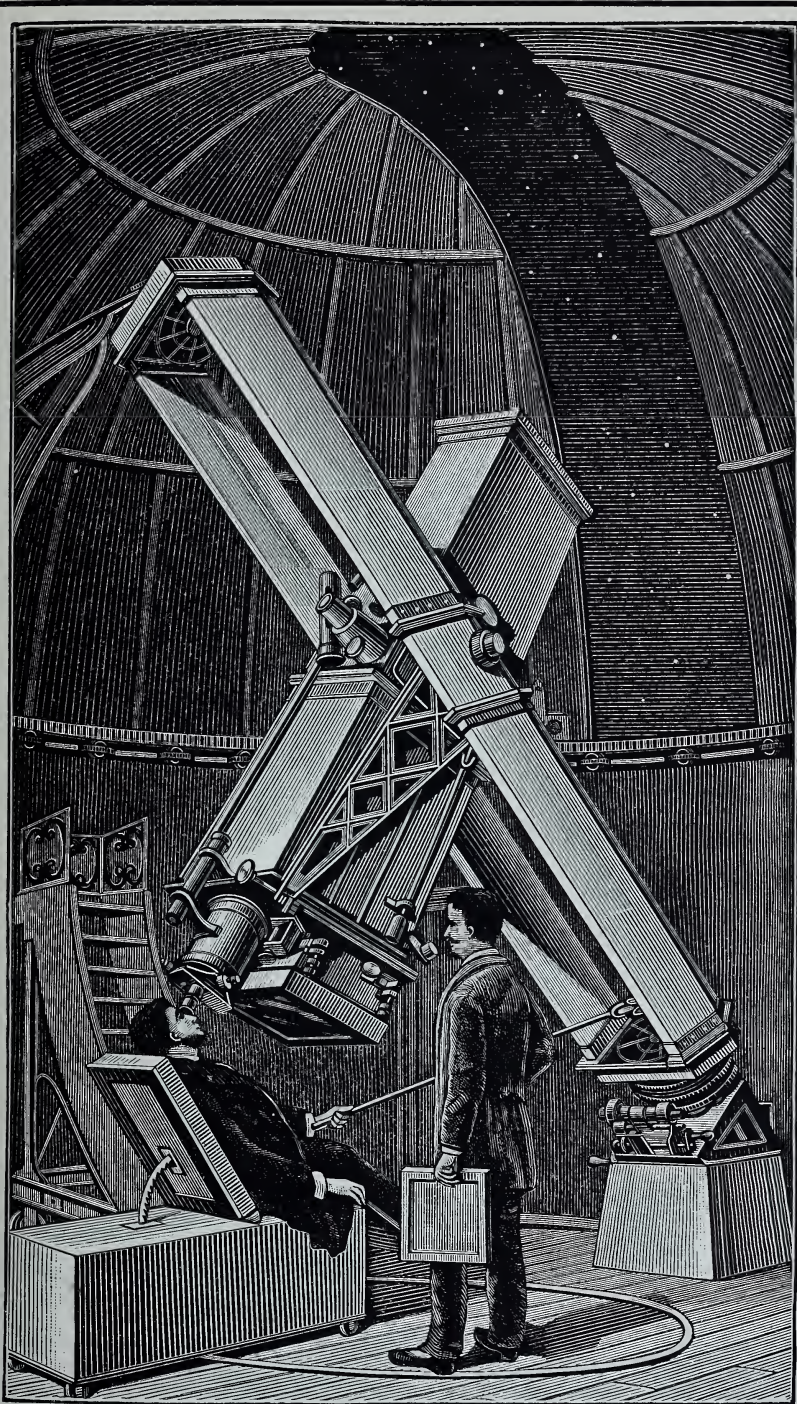

THE ASTRO-PHOTO-HELIOGRAPH OF THE PARIS OBSERVATORY.

but a small trunk in which a second and smaller cross axis turns ; to one end of this is attached a counterpoise, and to the other the telescope.

“By giving a proper position in rotation to the first cross-axis, the inclination of the second cross-axis to an astronomical meridian may be made any whatever, and therefore the inclination of the circle in which the telescope will sweep may be made any whatever ; and it may be made to coincide with the definite line drawn on the celestial sphere in which the comet is to be sought.”

The inventor thinks that an instrument of this kind would be found of great service to lunar photographers, as the difficulty of following the Moon with an equatorial is well known^r. There is one of these instruments at the Strassburg Observatory.

The *Comet-Seeker* is merely a cheap equatorial provided with an inferior object-glass and coarsely-divided circles, and optically contrived so as to possess an unusually large field in comparison with its aperture. It is an instrument more frequently met with in Germany than in this country.

The *Siderostat* is an instrument which was devised and named some 2 centuries ago by Hooke, a man who left no inconsiderable mark on English science. It has been left however for the present generation, under the inspiration of Foucault, to see siderostats made and used. The instrument is virtually a clock-driven equatorial minus the telescope tube, which is replaced by a mirror. The mirror being directed to a celestial object is kept constantly pointed towards it by the clock motion, and the image received by the mirror is examined by a telescope, which is so far detached and a fixture that when once the observer has got the whole apparatus ready for observing he has no occasion to shift his observing telescope, whatever be the quarter of the heavens to which his attention is directed. Of course such a combination of apparatus cannot command absolutely the whole of the visible heavens, but it is available over a considerable portion. For observations of the Sun, especially in connection

^r *Month. Not.*, vol. xxi. p. 159. March 1861.

with the spectroscope, the siderostat seems particularly well suited^s.

The application of the *Spectroscope* to astronomical purposes is comparatively recent. A spectroscope in its simplest conception consists of a narrow slit formed by a pair of knife-edges, capable of being adjusted by means of a screw. The rays of light admitted by this slit are received by a lens placed at its own

Fig. 106.

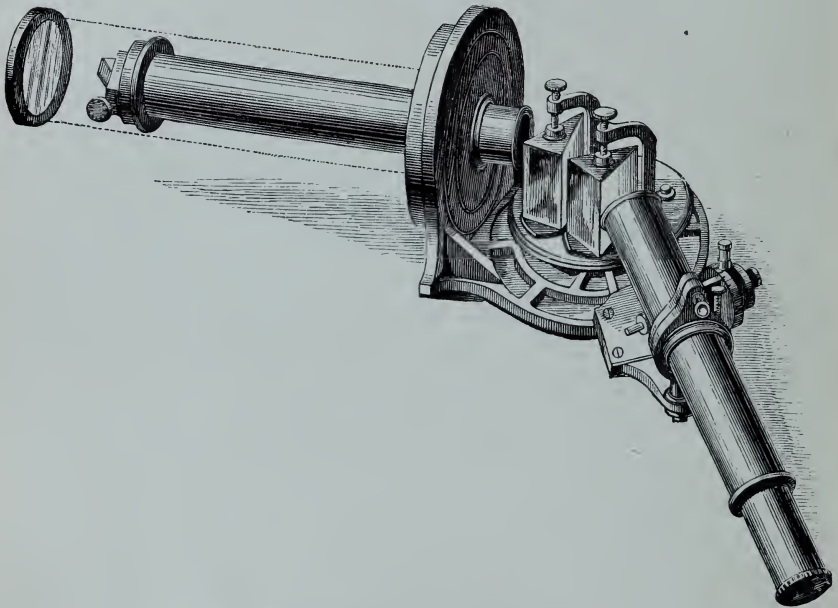

THE ASTRONOMICAL SPECTROSCOPE.

focal distance from the slit. In passing through this lens the rays are rendered parallel. They are then allowed to fall on a prism of any transparent substance of high dispersive power, by preference on one of extremely dense flint-glass. The spectrum produced by the passage of the light through the prism is then viewed by means of a telescope furnished with a Huygenian eye-piece of low power. To obtain the best definition, the prism should be placed at the angle of minimum deviation; that is, in such a position that the rays of light in traversing the prism are

^s Lockyer, *Stargazing*, p. 343.

equally inclined to its two faces. In the most powerful instruments a number of prisms, sometimes as many as 10 or 11, are arranged in a circle.

A simple form of spectroscope for astronomical purposes, devised by Browning, is represented in Fig. 107. A is a compound direct-vision prism consisting of 5 prisms. B is an achromatic lens which focusses on the slit C by means of a sliding-tube H; both the prisms and the lens are fastened in this tube. K is a small right-angled prism, covering half the slit, by the aid of which light may be seen reflected through the circular aperture in front of it. In this manner a comparison may be made with the spectra of metals or gases. The reflecting prism, with the ring to which it is attached, can be instantly removed, and the whole length

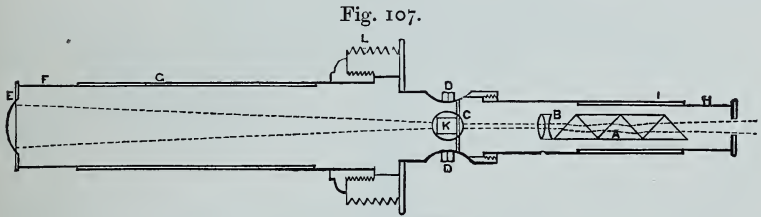

BROWNING'S STAR SPECTROSCOPE.

of the slit used if desired. DD is a ring milled on the edge; on turning this round, both edges of the slit recede from each other equally, being acted on by two hollow eccentrics. The lines can thus be increased in breadth without their original centres being displaced—a point of importance. E is a cylindrical lens attached to the tube F, which slides in another tube G. To use the spectroscope on a telescope the adapter needs only to have a thread which shall enable it to be screwed into the draw-tube of the telescope in the place of the ordinary Huygenian eye-piece.

The draw-tube must then be adjusted so that the slit C comes exactly to the focus of the object-glass. When stars, &c. are about to be observed, this point should be ascertained beforehand by the aid of an image of the Sun, some suitable mark to indicate the focus being made on the draw-tube of the telescope. When this

has been once done the tube can be set by this mark, and the spectroscope screwed in at any time without any trouble in adjustment.

If the cylindrical lens be absent the spectrum of a star will be a mere line of light. The cylindrical lens widens this line to such an extent that the lines in the spectrum may be readily discerned. For this purpose the lens must be placed *with its axis at right-angles to the slit*, and the best distance from the slit will be between 3 and 6 inches. The farther the lens is from the slit the broader will be the spectrum, but it should not be removed too far, or the light will be inconveniently diminished. When the spectrum of any celestial object possessed of considerable diameter in the telescope is to be observed, the cylindrical lens may advantageously be removed ^t.

A form of spectroscope even simpler than this for the purposes of amateur observers is McClean's "Star Spectroscope," also made by Browning. In this again there being no slit the instrument can be used with any telescope, and without a driving clock.

Spectroscopes, which consist of several prisms, are usually adjusted by finding the minimum angle of deviation for the brightest rays situated between the yellow and the green, for each prism which is then permanently secured to its supporting plane. There are, however, two objections to this arrangement. In the first place, only those rays for which the prisms are specially adjusted are seen under the most favourable circumstances, because they only pass through each prism in a line parallel to the base. In the second place, as the last prism is immoveable while the telescope travels in an arc from one end of the spectrum to the other, the object-glass of the telescope receives the full amount of light only when it is directed to the central part of the spectrum; and on the other hand, only a part of the light falls on the object-glass when the telescope is directed to one end of the spectrum, either the red or the violet, as the case may be. It is easy to see that in observing the ends of the spectrum, it

^t *Month. Not.*, vol. xxix. p. 326. June 1869.

is most important that the object-glass should receive the whole of the available light, since it is just these terminal colours that have least brilliancy; this can only be accomplished by the prisms being made adjustable for the minimum of deviation for whatever rays are under examination. Bunsen and Kirchhoff, in their investigations of the solar spectrum, attached the prisms of their compound spectroscopie to the ground-plate by means of moveable

Fig. 108.

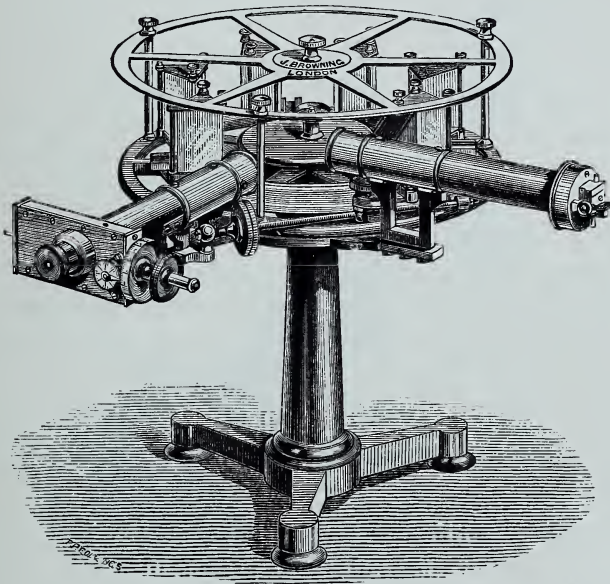

AUTOMATIC SPECTROSCOPE.

supports, and altered the position of the prisms for every colour of the spectrum as occasion arose; it is needless to remark that such an arrangement involved much trouble and inconvenience. This inconvenience is removed in the Automatic Spectroscope (Fig. 108), by so connecting the prisms with each other and the telescope, that on placing the instrument on any particular colour, the prisms, without any special action on the part of the observer, will be simultaneously and automatically adjusted for the minimum of deviation for that colour.

When several prisms are used, the first only is fastened in the ground-plate; the others are connected with each other by hinges at the corners of the triangular metal holders which form the bases. A metal rod, provided with a slit, is attached to the middle of this base, by means of which each prism can move round a central pin common to the whole set. The prisms are arranged in a circle round this pin, which again is fastened to a swallow-tailed moveable bar, about 2 inches in length, situated under the plate. If, therefore, the central pin be moved, the whole system of prisms moves with it, and the amount of motion communicated to each prism varies in proportion to its distance from the first or stationary prism; if, for instance, the second prism is moved 1° , the third prism moves 2° , the fourth 3° , the fifth 4° , and the sixth 5° , and so on. The tube of the telescope is fastened to a lever which is connected by a hinge with the last prism. At the other end of this lever, or on the carrier of the telescope, works the micrometer screw, by turning which the tube B can be directed upon any part of the spectrum issuing from the sixth prism. This lever is so adjusted that whatever may be the angle to which the telescope is turned, the amount of movement for the last prism shall be twice as great. The rays emerging from the middle of this last prism fall perpendicularly upon the centre of the object-glass of the telescope; the rays issuing from the collimator, and falling upon the first stationary prism, pass through the individual prisms in a line parallel to their base, and arrive finally on their emergence from the last prism, in the direction of the optical axis of the telescope, whether it be directed upon the central or the terminal colours of the spectrum; the object-glass is consequently always filled with light. As the tube is turned towards any colour of the spectrum, the lever sets at the same time all the prisms in motion, in such a manner that each adjusts itself to the minimum angle of deviation. The Automatic Spectroscope is generally recognised to be a great advance in the construction of compound Spectroscopes, by reason of the facilities it affords for good observation.

Fig. 109 is a Spectroscope for solar and general work. The first instrument of this form was constructed for Professor Young, of America, and contained many improvements designed by that well-known physicist. The collimator and observing telescope being parallel have their objective cells connected together, so that one motion of the pinion head affects the focussing of both simultaneously. The instrument is supplied

Fig. 109.

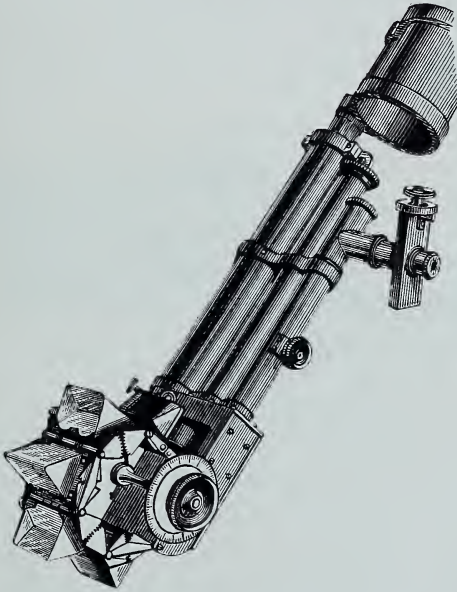

YOUNG'S ASTRONOMICAL SPECTROSCOPE.

with two half and four entire prisms of 60° angle, and as the pencil of light traverses twice through, the full power of the spectroscope is = 10 prisms of 60° , while this can be reduced in a moment to 8, 6, 4, or 2, if desired, by altering the position of the last half prism, to which is attached the prism of reflection for sending the ray back to the collimator.

Personal Equation Instrument. In some large observatories (*e.g.* Greenwich) use is made of an instrument thus designated which, applied to a Transit instrument, furnishes artificial Suns, Moons,

and stars moving with variable degrees of rapidity at pleasure before the observer whose eye-sight (or rather whose power to observe accurately) is to be tested^z.

The *Photometer* as an astronomical instrument is designed to measure the brilliancy of stars, it being both obvious and notorious that eye-estimates of the relative brilliancy of 2 or more stars must of necessity always be more or less uncertain and untrustworthy.

Much attention has recently been directed to the use of wedges of dark glass as a means of measuring the light of the stars. Professor Pritchard, Director of the University Observatory,

Fig. 110.

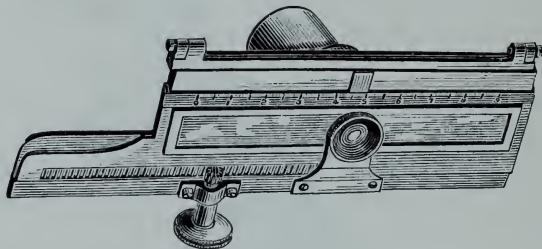

PRITCHARD'S WEDGE PHOTOMETER.

Oxford, has had constructed a photometer on the Wedge principle, and the results he has attained with it agree very closely with those obtained elsewhere by wholly different methods. His instrument consists of a wedge of shade glass of a neutral tint inserted in the field of view of the telescope, and movable so that a star may be viewed through the thicker or thinner portions at will. The exact position is indicated by means of a scale. The light of different stars is measured by bringing them in turn to the centre of the field, and moving the wedge from the thin towards the thick end until the star disappears. The exact point of disappearance is then read by the scale. The stars must always be kept in the same part of the field, or the

^z For a description of an apparatus invented by Professor J. R. Eastman, U.S.N., for experimentally dealing with the question of personal equation, see *Washington Observations*, 1875, Appen-

dix 1, p. 16. The instrument in use at Greenwich is described by the Astronomer Royal in *Month. Not.*, vol. xlvi. p. 1. Nov. 1887.

readings will not be comparable. By a long wedge the error from this source will be reduced. A second wedge in the reversed position will render the absorption uniform throughout the field. Instead of keeping the star in the same place by means of clockwork, the edges of the wedge may be placed parallel to the path of the star, when the effect of its motion will be insensible. To obtain the best results the work should be made purely differential, that is, frequent measures should be made of stars in the vicinity assumed as standards. Otherwise large errors may be committed, due to the varying sensitiveness of the eye, to the effect of moonlight, twilight, &c., and to various other causes.

A still further simplification of this photometer may be effected by substituting the diurnal motion of the earth for the scale as a measure of the position of the star as regards the wedge. It is only necessary to insert in the field a bar parallel to the edge of the wedge and place it at right angles to the diurnal motion, so that a star in its transit across the field will pass behind the bar and then undergo a continually increasing absorption as it passes towards the thicker portion of the wedge. It will thus grow fainter and fainter, until it finally disappears. In order to determine the light, it is now only necessary to measure the interval of time from the passage behind the bar until the star ceases to be visible. Moreover all stars, whether bright or faint, will pass through the same phases, appearing in turn of the 10, 11, 12, &c. magnitude, until they finally become invisible. For stars of the same declination, the variation in the times will be proportioned to the variations in the thickness of the glass. But since the logarithm of the light transmitted varies as the thickness of the glass, and the stellar magnitude varies as the logarithm of the light, it follows that the time will vary as the magnitude. For stars of different declinations, the times of traversing a given distance will be proportional to the secant of the declination. If δ , δ' are the declinations of two stars having magnitudes m and m' , and t , t' are the times between their transits over the bar and their disappearances, it follows that $m' - m$

$= A(t \sec \delta - t' \sec \delta')$. For stars in the same Declination calling $A \sec \delta = A'$ we have $m' - m = A'(t - t')$. Accordingly the distance of the bar from the edge of the wedge is unimportant, and, as, in Professor Pritchard's form of the instrument, it is only necessary to determine the value of a single constant, A , which is the light taken in magnitudes or fractional parts of a magnitude corresponding to 1 second of time occupied by the star in its passage behind the wedge. Various methods may be employed to determine this quantity; the following is one of them. Cover the wedge with a diaphragm in which are two rectangular apertures, and place a uniformly illuminated surface behind it. Bring the two rectangles into contact by a double image prism, and measure their relative light by a Nicol prism. From the interval between the rectangles and the focal length of the telescope the light in magnitudes corresponding to one second, or A , may be deduced. Perhaps the best method with a small telescope is to measure a large number of stars whose light has already been determined photometrically, and deduce A from them.

The great advantage claimed for this form of wedge photometer is the simplicity of its construction, of the method of observing, and of the computations required to reduce the results. It may be easily transported and inserted in the field of any telescope. The time, if the observer is alone, may be taken either by a chronograph or even by a stop-watch. Great accuracy is not needed, since if ten seconds correspond to one magnitude, it will only be necessary to observe the time to single seconds. The best method is to employ an assistant to record the time as taken from a chronometer or clock. To an amateur who would regard the complexity of an instrument as a serious objection to its use a means is now afforded of easily reducing his estimates of magnitude to an absolute system, and thus rendering them of real value^u.

^u Condensed from a paper by Professor E. C. Pickering in the *Proceedings of the Amer. Acad.*, vol. xvii. (N.S.) p. 231. 1882. Professor Pickering has himself invented a Photometer which he has called

the *Meridian Photometer*, and with it has accomplished a vast amount of valuable work. See for a description of this instrument *Annals of Harvard College Observatory*, vol. xiv. p. 1. 1884.

A useful astrometer, for determining star-magnitudes by the method of limiting-apertures, has been invented by Mr. E. B. Knobel^x. It consists of an equilateral triangular aperture which, though retaining the triangular form and always concentric, can be gradually reduced in size from the inscribed triangle to zero. To accomplish this the triangle is constructed of two plates, one of which forms the base, and the other contains the opposite angle. These plates are connected by a screw-shaft, the upper

Fig. III.

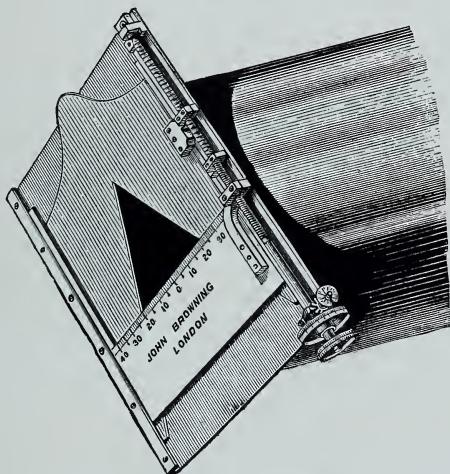

KNOBEL'S ASTROMETER.

portion of which, carrying the angle-plate, is a *right-handed* screw, and the lower portion carrying the base-plate is a *left-handed* screw: moreover the pitch of the upper screw is exactly *twice* that of the lower. By causing the shaft therefore to revolve, the plates either approach or recede from each other, the angle-plate moving twice as fast as the base-plate, which by a property of the equilateral triangle ensures the concentricity of the aperture. A micrometer-head fitted to the shaft gives accurately the length of the side of the triangle, whence the area is easily obtained. Browning turns out instruments of this make which are very perfect, and fulfil all the requirements of practical observers.

^x *Month. Not.*, vol. xxxv. p. 100. Dec. 1874.

Dr. Pearson's *Practical Astronomy* is very much out of date, yet the reader may be referred to it for a full account of many of the various matters touched upon in the preceding pages. Of more accessible books none surpasses Loomis's well-known *Practical Astronomy*. Challis's *Lectures on Practical Astronomy and Astronomical Instruments* may also be mentioned in this connection as a new and comprehensive volume. But the most complete treatise on astronomical instruments ever published is undoubtedly Dr. N. Von Konkoly's *Praktische Anleitung zur Anstellung Astronomischer Beobachtungen* published at Brunswick, 1883. It is so very complete and comprehensive that an English translation of it is much to be desired.

CHAPTER VII.

THE OBSERVATORY ^a.

Introductory statement.—The Bedford Observatory.—Choice of a site.—Foundations.—Details of the structure of the Observatory.—The Equatorial Room.—Construction of Domes.—Hemispherical Dome.—Drum Dome.—Polygonal Dome.—Bearings for a Dome.—Cannon Balls.—Movement of a Dome.—Transit Room.—Transit Room arrangements at Bedford.—Setting Circles.—Meridian Mark.—Observatory Clocks.—Hardy's Noddy.—The Chronograph.—Observing Seats and Chairs.—Dawes's Chair.—Cooke's Observatory ladder.—Ladder at the Dearborn Observatory.—Knobel's Observing Chair.—Plans and specifications for a 10-ft. Observatory.—Adaptation of the same to a private house.—The "Romsey" form of cheap Observatory.—Plans and specifications of the same.—The 30-ft. Lassell Dome at the Royal Observatory, Greenwich.—The Washburn Observatory, Madison, U.S.—The Lick Observatory, Mount Hamilton, California.

IN former editions of this work amateur astronomers were advised that it was in all cases more or less desirable that they should provide their instruments with shelter in the form of an Observatory, but no information was laid before them as to how this result had best be accomplished. It is now proposed

^a Though the subject in detail is quite beyond the scope of these pages it may be useful to some of my readers to have their attention called to a paper by Prof. E. C. Pickering presented to the American Academy in 1881, wherein he recommends that very large telescopes may often be used with advantage by being fixed in a *horizontal* position in the meridian, the objects to be examined being brought to the object-glass by means of a reflector (*Proc. Amer. Acad.*, vol. xvi. (= vol. viii., n.s.) p. 364, 1881; *Appalachia*, vol. iii. p. 99).

In *Month. Not.*, vol. xlix. p. 22, Nov. 1888, there is a table of 171 observatories, with their respective Latitudes and Longitudes.

For a description of one of the largest and most important observatories of modern times, M. Bischoffsheim's at Nice, see *L'Astronomie*, vol. iv. p. 206, June 1885.

For a good deal of historical information respecting observatories, old and new, see *Encycl. Brit.*, art. "Observatory."

to supply this omission, making considerable use of materials collected and employed by the late Admiral Smyth, which have been placed at my disposal by his representatives.

It is not too much to say that the Bedford Observatory directly or indirectly served as the model for nearly all the private observatories of moderate dimensions since erected in England, and it is equally certain that, whatever may be the changes which considerations of finance, or architecture, or geology, may render expedient in particular instances, no important alterations need be made in the main features of the Bedford Observatory, although upwards of half a century has elapsed since it was erected, and more than 40 years have passed away since it was pulled down.

In dealing with the architectural ideas of another man, with the view of annotating and developing his plans and descriptions for general use, it is not easy to amalgamate all the materials in a convenient and intelligible style. The reader must therefore ignore as far as possible the personality of the writer in this chapter and concentrate his mind on the matter of what he reads, without paying very particular attention to its authorship.

I propose in the first instance to describe the Bedford Observatory rather as if it were an abstract conception erected in a nameless place, using as far as convenient and expedient Admiral Smyth's words and woodcuts; then to give particulars of a useful and not expensive wooden observatory nearly on the model of one erected by myself at Sydenham in 1866; concluding with a description of a still less expensive structure erected at Austwick Hall, Lancashire, by Mr. T. R. Clapham, of which the original pattern was due to the Rev. E. L. Berthon, Vicar of Romsey, Hants.

In order to compress as much information as possible into a small compass I propose to classify what I have to say in such a way as shall successively conduct the reader step by step through the stages which he himself will have to pass through between the time when he determines to erect an observatory and the time when he finds himself the happy possessor of the completed

building. The only prefatory remark which seems requisite is this: that an amateur astronomer with only a given and moderate sum of money to lay out will do well to appropriate an adequate part of his funds to the purchase of a fairly good stand and of a suitable structure in which to house his instruments, rather than spend too much on his tube and then be obliged to starve the stand and to put up with inadequate shelter from the weather or no shelter at all. To begin, therefore, at the beginning.

THE CHOICE OF A SITE.

As to this the amateur will probably in most cases be obliged to suit himself as best he can. If his garden offers any varieties of site, he should endeavour to secure one on slightly rising ground, with an uninterrupted horizon to the South (for meridian purposes) and to the West (for comets and inferior planets in the vicinity of the Sun at sunset). A clear horizon to the East is of less moment, unless searches for comets before sunrise are intended to be systematically carried out.

In making preparations for building an astronomical observatory—and occasionally, indeed, for other purposes—it is necessary to know how to set out a meridian line. Of course this may be done by means of a mariner's compass (correcting for the magnetic deviation); but there are other ways of doing this independently of a compass, and as it is not always easy to ascertain the deviation, a statement of at any rate one of these other ways, as given by Challis, will be useful. Set up a pole at the spot through which the proposed meridian line is required to pass, using a plumb-line to ensure the pole being vertical. Draw around the pole as a centre several concentric horizontal circles, and mark the points of coincidence of the extremity of the shadow of the pole with these circles both before and after noon. Then if the two points on each circle be joined by a chord, the mean of the directions of the middle points of the chords from the pole will be approximately the direction of the meridian line. This method answers best about midsummer,

when the sun's diurnal path is high in the heavens and the change of declination is small. A little forethought must be displayed in suiting the dimensions of the circles to the height of the vertical pole employed.

FOUNDATIONS.

The foundations of an observatory are a matter of great importance, and unless a rock^b or chalk bottom can be readily obtained, an artificial bottom of concrete, more or less thick according to the height of the intended superstructure, must be made. This of course applies to the piers which are to carry instruments. In the case of the observatory itself, especially if the material of the fabric is to be of wood, which is so often used, the ordinary precautions against settlement taken by a competent builder will suffice. As no fire-place is permissible in an observatory because of the disturbing currents of air to which fires give rise, special precautions must be taken to protect the building and its contents against damp, and the consequences thereof. In heavy clay soils clear away the soil all around the outside of the observatory by making a trench, say 10^{ft} wide and 4^{ft} deep, and fill up the excavation with broken bricks, coarse gravel, or other hard porous material. Provide by suitable gutters and pipes that all rain-water falling on the observatory shall be carried away to a distance as quickly as possible.

DETAILS OF THE STRUCTURE OF THE OBSERVATORY.

Fig. 112 represents the ground-plan and Fig. 113 the elevation of the Bedford Observatory. The external dimensions were about 35^{ft} by 13^{ft} 6ⁱⁿ. The building was divided into two apartments: (1) an equatorial room, circular, and 15^{ft} in

^b A rock foundation is not necessarily the most stable possible, and some authorities deem a sandy substratum best. Moesta at Santiago found that the rock on which the Santiago Observatory was erected became so heated by

the Sun during the daytime that variations in Azimuth to the extent of 0.5° in 12^h were common (André and Angot, *Observatoires de l'Amérique du Sud*, p. 10. Paris, 1881).

diameter on the inside; and (2) a transit room, 17^{ft} by 12^{ft} on the inside, and 10^{ft} high. At Bedford the transit room contained a transit circle and a transit instrument, with a clock so placed that it could be used with either, as wanted; but an ordinary

Fig. 112.

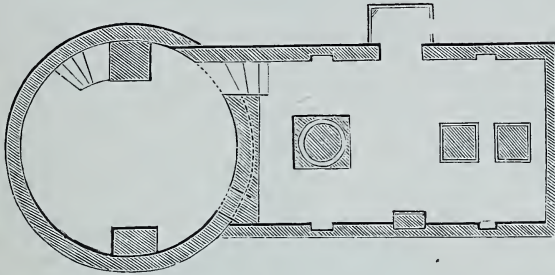

GROUND-PLAN OF THE BEDFORD OBSERVATORY.

amateur will only need to have one meridian instrument, and the surplus space may advantageously be partitioned off to form a calculating-room, or the space may be used as an ante-room,

Fig. 113.



ELEVATION OF THE BEDFORD OBSERVATORY.

and the entrance door put there, and not on the north side, as at Bedford.

It will now be convenient to describe the several parts of an observatory more in detail.

THE EQUATORIAL ROOM.

The equatorial being the principal instrument in every amateur's observatory, the provision made for its accommodation deserves attention first. It is not an uncommon practice to arrange that the floor of the equatorial room shall be 2^{ft} or 3^{ft} below the level of the adjoining room, and where a large equatorial is worked with a small transit instrument used merely for setting the clock, and economy and difficulties of site have to be considered, a sunken equatorial room may be unavoidable. But all the same the practice is highly inconvenient and objectionable. An observer should be able to move rapidly from one part of his observatory to another in the dark, and without having to think of steps up or steps down. Moreover, in order to secure free internal ventilation nothing more substantial than a green baize curtain should separate the equatorial room from the transit room, and it is obviously not safe to use such a curtain where it will conceal a difference of level of 2^{ft} or more.

Fig. 112 contemplates an equatorial of what is called the "English" form, with two separate piers for the support of the polar axis; but this construction of equatorial has become almost obsolete, owing to its numerous practical disadvantages, and the "German" form, with one pier and pillar, centrally placed, is now all but universally used, at least by amateurs.

The construction of a roof for an equatorial room (technically called the "dome^c," whatever may be its precise form) is a great *crux* to the intending builder of an observatory^d. Theoretically the hemisphere is the proper form, and roofs truly hemispherical are occasionally met with; but they are extremely troublesome and expensive to make, and can only be tackled by professional engineers.

^c French, *Coupole astronomique*.

^d The earliest recorded instance of a moveable dome surrounding an astronomical Observatory would seem to be the "revolving rounded part" of the tower which formed the Observatory

established at Cassel by William IV., Landgrave of Cassel (d. 1592). The historian expressly states that it could be turned so as to be directed to any part of the sky.

Fig. 114 represents the skeleton frame of such a dome of large dimensions, before the sheet copper, or other material to be employed in covering it, has been put on. Of late years, especially for large observatories, "drum" domes have come much into use as comparatively easy to construct, and capable of being made strong and watertight; but they offer much resistance to the wind, and architecturally are bound to be ugly.

Fig. 114.

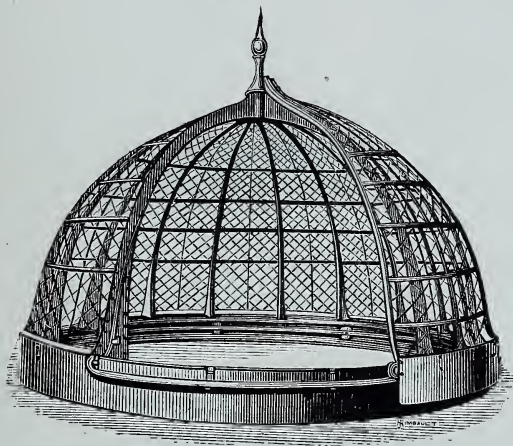

DIAGRAM SHOWING RIBS OF A DOME. INTENDED TO BE COVERED WITH COPPER OR SHEET IRON.

For the purpose of protecting the smaller sizes of equatorials, say those from 4ⁱⁿ to 7ⁱⁿ in aperture, a conical or polygonal dome of the form engraved in one or other of the lithographed Plates (*post*) is recommended. Or, in the case of equatorials of the smallest size, say from 2½ⁱⁿ to 5ⁱⁿ, the roof of the equatorial room may be flat, and arranged to open by sliding it to one side. Such a sliding roof should not be quite mathematically flat, but should have a slight inclination, to throw off the rain.

Whatever be the form of the dome chosen, the problems, how to uncover a slit in it and how to move the whole of it, are matters which require in all cases careful consideration. Where the dome is a large one, say more than 12^{ft} in diameter, the

shutters which close the slit should slide. They may be arranged to slide laterally on a suitable staging, or to slide up and down. The latter is a very convenient expedient, especially when the observatory is to be erected in a situation exposed to strong winds, or when the telescope is to be much used on the sun; for the observer can open just so much space as will uncover the whole aperture of the telescope, and can keep himself and the greater part of his telescope protected from the direct impact of the wind, or the direct rays of the sun, as the case may be. When arranged in the best form the shutters will be three or four in number, each protecting a third or fourth of the slit, measured vertically. Each shutter must have its own rabbet, and its own ropes and pulleys, in order to enable the observer to open at one time only so much of the whole slit as is necessary to enable him to scrutinise the particular portion of the heavens which he desires to examine. The advantage of thus being able to shelter himself and his telescope will soon be appreciated in windy weather or under a meridian sun by the owner of an observatory fitted with sliding shutters.

Another important matter is the question of the bearings on which a dome is to be mounted. Large domes can only be made to move with facility by the aid of mechanical appliances which are often in practice both complex and cumbersome, and needing much muscular effort on the part of the person who has to move the dome. Where the weight of this does not exceed a ton, a set of grooved wheels running in a concave wall-plate of iron generally works well. For weights beyond this, special mechanical appliances must be used, which it is foreign to my present purpose to treat of. On the other hand, light domes—by which is meant domes up to, say, half a ton—are best dealt with by being mounted on iron balls (cannon balls in fact) travelling on a circular wall-plate, and kept in place by an upper plate, the arrangement being such as is indicated in Fig. 115.

The ironwork may be simplified in character and lessened in weight if the arrangement suggested in Plate XXVII be adopted.

The balls need only be 3 in number where the diameter of the dome does not exceed 10^{ft}. If the diameter is greater than that, a fourth ball may be desirable in order to distribute better the weight, and lessen the risk of the framework of the dome being strained. The diameter of the balls may be 4ⁱⁿ or 5ⁱⁿ (say 24-pounder or 32-pounder balls), and the more truly spherical they are the less the friction, and consequently the less the muscular effort, required to impart motion to the dome; and to this it may be added the less likely are the balls to approach one another after being some time in use and so in a sense dismount the dome. When this does happen, the dome must be slightly prised up by means of a lever or jack, and the balls separated and set at a distance from one another of 120° or 90°, according as there are 3 or 4 of them. It is convenient to have marks put on the upper plate of the equatorial room to indicate where the balls should be when at their proper equal distances, so that a slight inspection will at any time show whether they need any adjustment.

Where the dome is a light one, mounted on cannon balls, motion may be imparted to it by the simple process of pushing a long and strong handle which descends from the roof to a sufficient distance towards the floor; in other words, which is 4^{ft} or 5^{ft} long. Such a handle will be noticed in Fig. 53 immediately behind the observing chair. Where a handle of this sort is used it should be affixed to the dome by strong screws or bolts, exactly opposite the shutters which cover the main opening, because when so placed the observer can grasp the handle and bring the openings exactly to that part of the

Fig. 115.

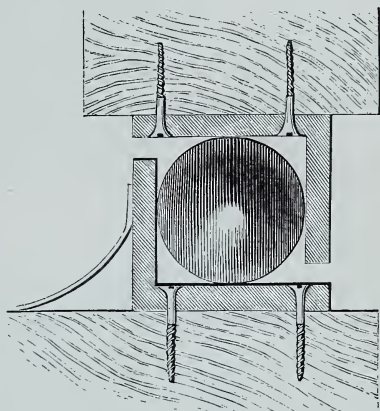
SECTION OF BEARINGS FOR A DOME
(BEDFORD OBSERVATORY).

heavens to which he has pointed his telescope, and can be sure that he has done so. In this facility of being able to watch how far the dome is moved resides the great advantage of the fixed handle; its disadvantage is that the observer in moving the dome has to follow it himself by walking round on the floor. To obviate this inconvenience, such as it is, some prefer a fixed wheel permanently attached to some one place in the wall of the observatory, and having cams in its periphery to catch suitable pins attached at short intervals to the inside circumference of the revolving dome.

Whatever may be the form of the dome, it is evident that in plan it must at the bottom be circular, and that the wall-plate must be circular also, and of the same dimensions. But the plan of the equatorial room, as regards its walls and floor, is another question. Where the room is large, say 15^{ft} or 20^{ft}, or more, in diameter, it will be best that it also should be circular, or perhaps octagonal. Where, however, the dome is not more than 12^{ft} across, and consequently the whole establishment is on a small scale, there are great advantages in making the equatorial room square. In such a case the corners will be found very useful for various purposes: for instance, in one a desk or writing-slab may be fixed; in another, the clock; in a third, a lamp; whilst the fourth corner may take a chair or a stool. In other words, the corners become available as places of refuge for things and persons whilst the observer is turning the dome round from one part of the heavens to another. Moreover, the cost of building a square room is less than the cost of building a polygonal one, because the difficulty is less, be the material brick or wood. If wood is employed for the walls of an observatory, it will in all cases be desirable to place the frame on a dwarf wall of brick-work rising at least 2^{ft} above the general level of the ground.

The floor must be supported on joists, trimmed so as to form square frames around the piers which are to carry instruments. This will enable the floor-boards to be fixed firmly, yet quite clear of the piers, and will prevent tremors, caused by persons passing over the floor, being conveyed to the piers, and so to the in-

struments. A free circulation of air must be secured by means of small brass ventilating gratings suitably disposed around the floor near the walls.

Making due allowance for the different purposes for which it is to be used, many of the remarks just made with respect to the equatorial room will apply also to the transit room. The main part of the roof is a fixture, but an opening about 1^{ft} 6ⁱⁿ wide has to be made right across the top, and to be continued into the

Fig. 116.



THE OBSERVATORY AT QUEEN'S COLLEGE, CORK.

North and South walls from the eaves downwards towards the floor, so as to enable the observer to sweep the meridian with the transit instrument from the South horizon through the zenith to the North horizon. The openings must be protected by shutters, which may either slide or lift. For large observatories Grubb has devised a form of balance shutter which swings, and is said to work well. It will be seen that the transit room of the Observatory at Queen's College, Cork, is fitted with such a shutter.

In cases where the top transit shutter, which constitutes part

of the roof, is in the form of a flap and lifts, it must be counterpoised by a weight or weights travelling up and down inside the room. The vertical shutters must be treated as casements, and be fitted with handles and fastenings accordingly. The remarks made in speaking of the equatorial room as to the advantages offered by sliding shutters or sashes, apply equally to the case of sliding shutters for a transit room.

Light should be obtained for an observatory by independent windows, and not, as in Fig. 113, by panes of glass inserted in the shutters; for glasses are very apt to get broken by the constant moving of the shutters.

The transit instrument as such we have considered in Chap. IV. (*ante*), but it may be worth while to show how a transit instrument is mounted where space is no object, and the instrument is intended for the determination of Right Ascensions rather than for the commonplace purpose of setting a clock.

The transit instrument at Bedford consisted of a telescope of $3\frac{1}{2}$ ft focal length furnished with an object-glass whose aperture was $3\frac{1}{4}$ in; the telescope was supported by broad cones forming an axis 28in long, the pivots of which rested on covered Y's offering a surface of polished Brazilian pebble an inch in bearing, and which (owing to their bases being hemispherical and working in corresponding sockets) held their proportionate weight, as well as ensured the axis of the pivots being always strictly in the same right line. The Y's were placed on improved cheeks whose azimuthal and vertical motions were effectually secured from dust and injury, and left the shoulders of the pivots just sufficient room for moving without friction; the Y's were morticed upon 2 piers of Portland stone rising $5\text{ft } 7\text{in}$ above the floor, and which with their bases weighed a ton each. The axis of the instrument was perforated at one end in the usual way for the admission of light from a lamp at night, but it also contained a contrivance for regulating, by means of a milled head on the telescope tube, the light falling on the wires; and there was, moreover, a rack-screen to the lamp for the same purpose. In the optical focus were five principal vertical wires

(besides two for the Pole-star) crossed by one horizontal wire; with a slide and divided scale for bringing the axis of the eye tubes exactly over the respective wires, and thereby destroying

Fig 117.

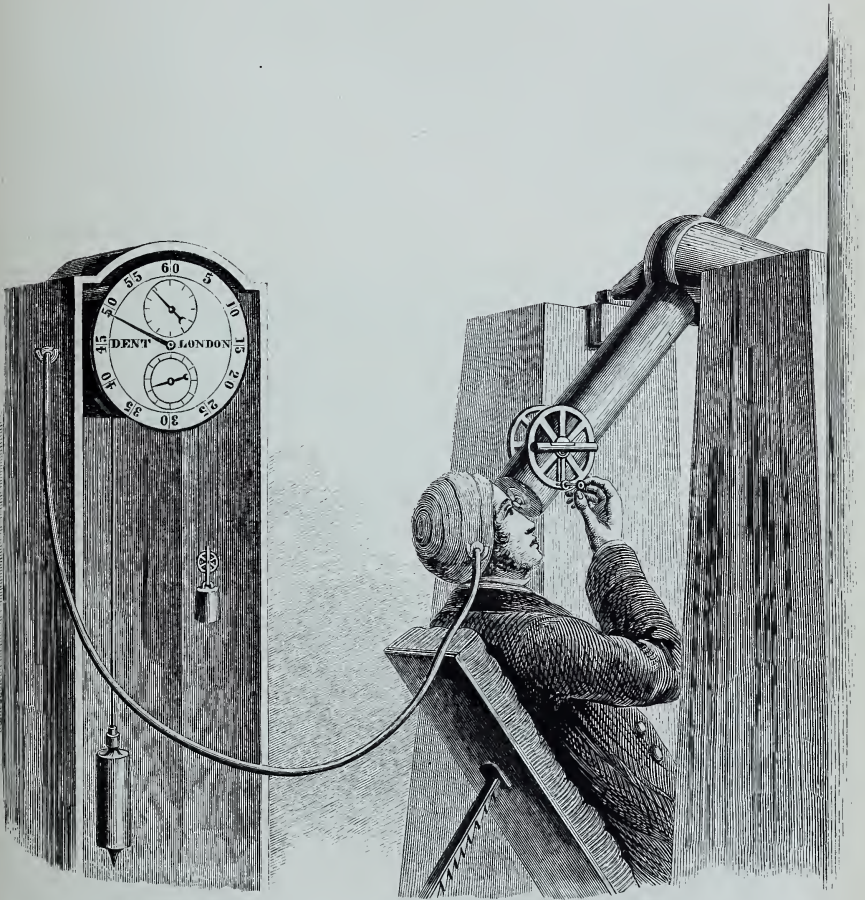

THE TRANSIT INSTRUMENT OF THE BEDFORD OBSERVATORY,
WITH OBSERVING CHAIR AND CLOCK.

parallax. This part of the tube was also fitted with a simple means for adjusting the eye-piece to the solar focus, and for taking out the frame bearing the spider lines in case they needed examination or repair. For setting the telescope the eye-end

was furnished with two circles, 6ⁱⁿ in diameter, each provided with a level and showing altitudes and zenith distances. But it is strongly recommended that such circles should in all cases be graduated and adjusted so as to show Declinations^e.

Setting circles attached to the eye-ends of telescopes are so extremely convenient for approximate settings that it is a matter of surprise that they are not more generally used. They are thought to have been invented by Troughton, and to have been first applied in 1816 to the Greenwich transit instrument. As to this, Smyth has a note as follows:—"Mr. Jones lent me a note-book of the late Mr. Walker, of *Eidouranian* memory,

Fig. 118.

SETTING CIRCLE DEvised
BY RAMSDEN.

in which he describes a visit he made to the celebrated Jesse Ramsden in 1780; and mentions that he was shown an ingenious mode of elevating a transit instrument by a circle of about 3ⁱⁿ diameter and a level at the eye-end. The vernier fixed and the circle with its attached level moveable.

To this statement is the sketch of a telescope so fitted, the accompanying portion of which I traced^f."

MERIDIAN MARK.

This is an accessory to the transit instrument, so useful and so convenient that it is a matter of surprise that a meridian mark is not more generally provided in connection with transit instruments. It affords by day, and, if illuminated, also by night, a means of verifying the meridian adjustment of the transit instrument. Fig. 119 represents the meridian mark used in connection with the Bedford Observatory. A plate of brass about $\frac{4}{10}$ ⁱⁿ thick, 5ⁱⁿ long, and 3ⁱⁿ wide was fastened by 4 screws, passing through its corners, to a stone, into which 4 brass sockets to receive them had been made fast

^e For information as to how this is to be brought about, see Challis's

Lectures on Practical Astronomy, p. 26.

^f Smyth, *Cycle*, vol. i. p. 330.

by molten lead. On this plate it was arranged that another of the same thickness should slide; this was $3\frac{1}{2}$ in long by $1\frac{1}{2}$ in broad, and was attached to the former by dove-tailed side-pieces, and was capable of being adjusted by two long screws pressing against its ends. In the plate there were 4 slots to receive 4 capstan-headed screws, by means of which the sliding-plate could be firmly made fast to the fixed plate after the mark had been duly adjusted to the meridian. This done, the end screws were withdrawn to prevent the possibility of their being tampered with and the mark displaced

Fig. 119.

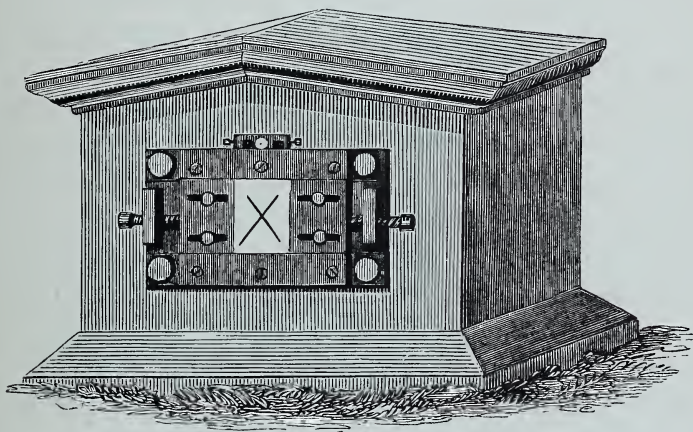

MERIDIAN MARK.

from the meridian. On the sliding plate there was soldered a square piece of silver exhibiting a well-defined black cross, the centre of which was to mark the actual meridian. As this cross taken by itself hardly afforded sufficient vertical length for comparing the wires of the transit a small circle of silver (with a black dot in its centre) was placed above the cross as an auxiliary mark. This silver circle, like the larger silver plate below, was capable of lateral motion by means of capstan-headed screws which could be removed when the dot had been brought exactly over the cross below. The stone to which the mark was fixed was firmly mortised into a dwarf pier, to guard

against lateral movement, and the whole superstructure was firmly bedded on a solid substructure sunk into the earth. It is of the utmost importance to guard against settlements likely to cause any lateral movement, for it must be remembered that with a 50-foot radius a displacement of about $\frac{3}{1000}$ inch is equivalent to one second. The remaining and important part of the arrangement at Bedford was a 4-inch lens of $49\frac{1}{2}$ feet focus, being exactly its distance from the diaphragm. This lens was mounted in a brass collar, and having been attached by screws to a plate of cast-iron, was let into the wall of the transit window in a line with the transit instrument and the meridian mark. It is evident that the rays of light from the meridian mark become parallel after passing through the lens, and that the diaphragm can therefore be viewed through the telescope of the transit instrument as adjusted to solar focus. Another consequence of the rays being rendered thus parallel, is that no parallel motion of the transit axis would cause a change in the place of the object seen, so that the meridian is a line drawn from the *diaphragm* through the axis of the lens; and provided that these two points remain rigidly permanent, they offer all the advantages of a very distant meridian mark. And after all, a distant mark when obtainable can still be used as a check to the home mark. It will often happen that an observer will be able to find at the distance of a mile or two, or even of several miles, some well-defined line or point—*e.g.* a window sash, or the pinnacle of a church, or a piece of squared stone, which will serve him as a meridian mark for the simple reason that it lies in the meridian of his transit instrument.

Brodie recommends a meridian mark constructed as follows:—A brass pin $\frac{3}{4}$ in diameter and 3 in long, with claws formed at one end the better to obtain a hold for the pin in the masonry, is embedded in a brickwork pillar. Upon the pin a disc of brass $2\frac{1}{2}$ in diameter turns freely, but can be fixed by a wedge working in a slot in the disc. On one side of the centre of this disc a smaller disc of iridium about 1 in diameter is fixed. This iridium disc has in its centre a black

dot, whilst in the centre again of the black dot there is a fine point of iridium which shows as a white speck on a black ground. It is obvious that this white speck has, by reason of the way in which the discs are mounted, a play from one side to the other of the main pin which amounts laterally in all to about 2^{in} —quite sufficient for the ordinary purposes of adjustment in the case of a meridian mark.

CLOCKS.

A clock is a very important article of furniture in every observatory.

Whilst a proper sidereal clock showing 24 hours is what an amateur should have, he can very easily make shift with a much less pretentious time-piece, especially if his equatorial is provided with the best modern form of driving clock which only requires to be set once, or occasionally, during an evening's work. Indeed all that is essential in such a case is really a good dining-room clock (with its pendulum adjusted to sidereal time), which once set at the commencement of an evening by means of a transit instrument can be depended upon to maintain a tolerably even rate for half-a-dozen hours. The price of sidereal clocks for observatory purposes has been much reduced of late years, and from 20*l.* to 30*l.* will now command a fairly good one. If you have a clock made for you, insist on having white graduations and figures on a black ground. The advantages of this, by night especially, are very great, but it is extremely difficult to make clockmakers believe this. For the purpose of the ordinary amateur, a perfectly straight-grained deal rod $44\cdot5^{\text{in}}$ long, saturated with melted paraffin, and with a leaden bob $2\frac{1}{4}^{\text{in}}$ in diameter and from 10^{in} to 12^{in} high, forms as good a compensated pendulum as need be wished. The pendulum of the Standard Sidereal Clock at Greenwich has zinc and steel compensation.

For astronomical purposes when great exactitude is required the observatory clock should be provided with a mercurial pendulum, this form of pendulum having been found by ex-

perience to be the best. A "mercurial pendulum" comprises a

Fig. 120.

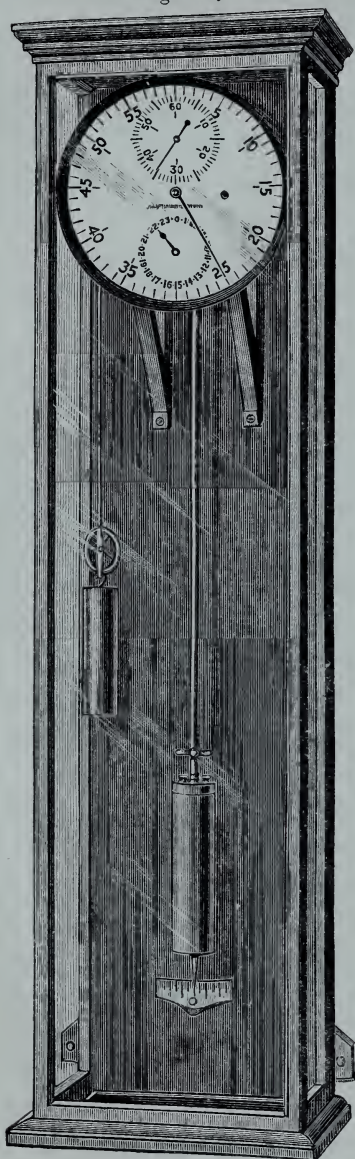

OBSERVATORY CLOCK. (By Cooke.)

steel rod with a bob in the shape of a cylindrical glass vessel to contain the mercury. The advantage of this arrangement is that the astronomer himself without any help from the clockmaker is able both to alter the clock's rate and to correct imperfect compensation.

The following remarks by Challis^g on the management of clocks with mercurial pendulums, though rather wordy, will be useful to many:—

“For altering the clock's rate, the mercury is put in a glass cylinder attached to the end of the pendulum rod, and by turning a screw the cylinder and contained mercury may be raised or lowered relatively to the rod. As the weight of the mercury constitutes the chief part of the weight of the pendulum, this operation changes the position of the centre of oscillation, and, by consequence, the time of an oscillation of the pendulum. A small graduated circular disk, attached to the stem of the screw and turning with it, is read off by an index fixed to the rod. It being understood that the clock's rate is its gain

^g *Lectures on Practical Astronomy*, p. 99. As regards the construction gener-

ally of clocks for astronomical purposes see Godfray's *Treatise on Ast.*, p. 34. A

or loss upon 24 hours in the sidereal interval between consecutive meridian transits of the same star, let the index be set to a certain reading and the clock be rated, by transits of stars taken *ad libitum*, in the manner stated [elsewhere]. After altering the index-reading by a certain integral number of divisions, let the clock be rated in the same manner again. The difference of the index-readings and the corresponding difference of the rates being noted, the index-reading which would correspond to a certain desired rate might then be found by a simple proportion, and the length of the pendulum might be altered accordingly. For convenience as respects the reduction of transit observations it is usual to maintain a small losing rate, the minute-hand being put forward when the clock's loss exceeds one minute.

“Compensation for changes of the length of the pendulum produced by changes of temperature is effected by the mercurial pendulum in the following manner. The cylindrical column of mercury, being uncovered at the top, is free to expand upwards upon an increment of temperature, which, therefore, has the effect of raising the centre of gravity of the mercury, and, by consequence, the centre of oscillation of the pendulum. At the same time the pendulum-rod, by expanding downwards from the point of suspension, produces the opposite effect as respects the position of the centre of oscillation. When these two results of the change of temperature just counteract each other, the required compensation is effected, the distance of the centre of oscillation from the point of suspension, and consequently the time of an oscillation of the pendulum, being thereby made invariable. Analogous reasoning applies to the effects of a decrement of temperature. Now the astronomer is in a better position than the clockmaker for telling whether or not the compensation be good, because for doing this completely exact transit observations carried on through the hottest and coldest parts of at least one year are required. It is the special advantage of the

good deal of useful information on pendulums and astronomical clocks and chronometers will be found in Lockyer's *Stargazing*, p. 183 *et seq.* For much

practical information respecting chronometers, see Captain C. F. A. Shadwell's *Notes on the Management of Chronometers*, 2nd ed. 1861.

mercurial pendulum that it gives the astronomer the means of correcting the compensation if found thus to be imperfect. Supposing, for instance, the observations to show that the losing rate comes to a maximum in the hot months, this will indicate that the length of the pendulum is at that time too great, and consequently that the effect of the expansion of the rod is greater than that of the expansion of the mercury. The clock is in that case under-compensated, and requires an addition to be made to the quantity of mercury; or if it be found that the losing rate diminishes in the cold months till it attains a minimum, the pendulum is then too short, and the contraction of the pendulum-rod by the cold is not compensated for by the contraction of the mercury; that is, as before, the clock is under-compensated. But if the clock goes faster in the summer months or slower in the winter months than in spring or autumn, it is over-compensated, and requires that some mercury should be taken out of the cylinder."

It must also be mentioned that the pendulum of a clock, besides being affected by changes of temperature, is also affected by changes of pressure. An alteration of 1ⁱⁿ in the height of the mercurial column of the barometer will soon make itself perceptible in the rate of a delicately-adjusted clock. But an amateur observer need not trouble himself with this.

Where an observatory includes a transit room the clock should of course be placed so as to be visible both to an observer sitting at the transit instrument and facing the direction in which transits are most usually taken (that is, for the Northern hemisphere, South) and also visible to an observer working with the equatorial. This desirable combination makes it expedient that the equatorial room should be at the West end of the buildings; but local reasons connected with the site of the observatory may not always render this possible.

For the clock there should be provided a stone pier constructed and isolated with much the same precautions as those already suggested in respect of the piers prepared to carry the telescope.

On the top of the clock case there is sometimes placed a "Hardy's noddy." This is a small and sensitive inverted

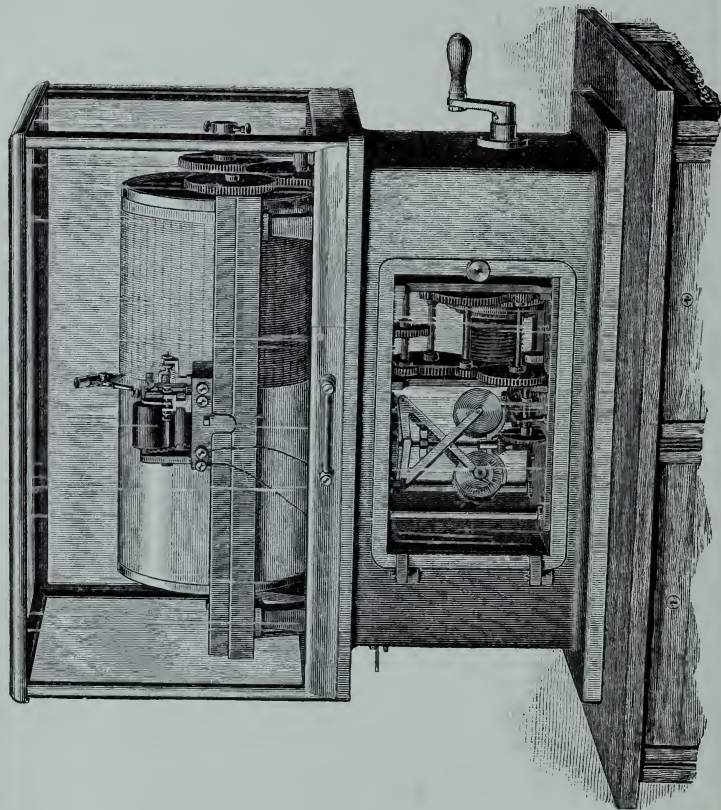

AMERICAN CHRONOGRAPH.

pendulum inclosed under a glass bell and standing on a frame provided with three adjusting screws to level it. The use of the nobby is to discover whether the pendulum of the clock imparts any motion to its supports. But this is a refinement with which in a general way amateur observers need not concern themselves.

THE CHRONOGRAPH.

This can hardly be regarded as an amateur's instrument, but I mention it here in case any of my readers may like to provide themselves with such a luxury. It is a very complex piece of apparatus, but in principle amounts to this: a good clock by means of accessory wheel-work imparts motion to a cylinder, which has a sheet of white paper completely wrapped round it. The motion imparted to the cylinder is of a two-fold character, axial and longitudinal, and is so contrived that any given point on the cylindrical surface moves through a definite distance in a definite time—say half-an-inch in one second. By suitable magnetic appliances the observer at a Transit Instrument can cause punctures to be made in the paper on the revolving cylinder just at the instants between the whole seconds of the sidereal clock at which he estimates the passing star to be bisected by the successive wires of the transit instrument.

OBSERVING SEATS AND CHAIRS.

For a large telescope a specially constructed observing-chair is needful, but in working with a small one I have found that a dwarf pair of carpenter's steps, an ordinary music-stool, and a foot-stool suffice to give all the change of position usually requisite. A box without a lid and strong enough to bear the observer's weight is very useful: if made of the following dimensions it affords a seat or a standing-place giving in turn 3 different and convenient elevations above the floor: length, 21ⁱⁿ; breadth, 12ⁱⁿ; height, 15ⁱⁿ.

Dawes contrived^h an observing-chair, for which he claimed the merit of convenience and simplicity combined with com-

^h *Month. Not.*, vol. xxviii. p. 9. Nov. 1867.

parative inexpensiveness. Fig. 122 will enable its construction to be understood. The angle of the slanting upper part of the frame is about 30° . In the left-hand slanting-timber there are a number of notches, and attached to the sliding body or chair is a stout catch, which falls into the notches one after another as the chair is raised. When the catch is lifted by the observer's left hand the chair will descend.

The back of the chair is supported by an iron quadrant toothed on the under side; and a catch is forced by a spring into the teeth as the back is raised, to support it at any convenient elevation. The catch can be pushed out of the teeth

Fig. 122.

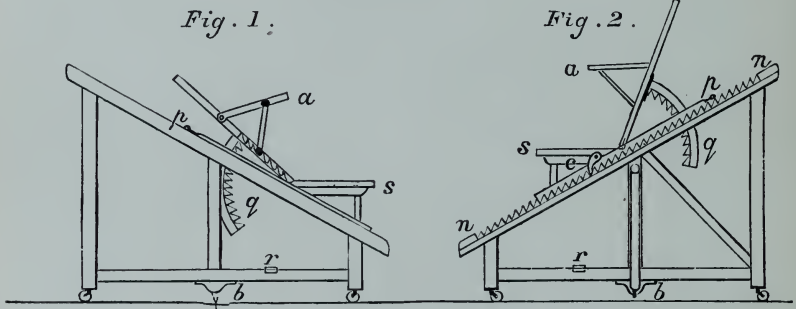

DAWES'S OBSERVING CHAIR.

by the observer reaching behind him with one hand, while he diminishes the slope of the back with the other hand. On the right-hand side of the chair is an arm, which can be adjusted at pleasure to support the observer's elbow, and aid in keeping the hand steady in the management, for instance, of a micrometer.

The angle which the slanting frame makes with the horizon is so arranged that when the seat is raised nearly to the top, the observer's eye may be about the same height from the floor as it would be if he were standing. Of course the angle may be varied with regard to the distance of the pillar of the equatorial from the wall of the room, and to the height of the declination axis above the floor.

On the left side of the frame, attached to the upright timber

strut near the middle of the frame, is a long stout bolt with a sharp point, so arranged as to be free of the floor when up, and to pierce the floor when pushed down. This enables the observer to *cast anchor*, as it were, to the detriment, however, of the floor.

The following is a more particular description of the several parts:—

Fig. 1. *Right side.*

- a. *Moveable arm*, for supporting the observer's elbow.
- b. *Bolt*, for anchoring. Sharp point pushed into floor.
- p. *Pin*, by pressing which the spring is pushed out of the teeth of the quadrant q.
- r. *Rail* across the lower frame for supporting the feet thereof. May be removed if in the way of the quadrant q.

Fig. 2. *Left side.*

- a. See Fig. 1.
- b. *Bolt*, as fixed on the middle upright timber; represented as *drawn up*.
- c. *Catch*, which falls into the notches (n n) in the slanting timber, and supports the seat (s).
- p. See Fig. 1.
- q. *Iron-toothed quadrant*.
- r. See Fig. 1.

Fig. 123.



OBSERVATORY LADDER.

Fig. 123 is a simple form of observatory ladder made by Cooke, the treads of which fold back as may be required.

Fig. 124 is a more elaborate observatory ladder devised by Hough and Burnham for use at the Dearborn Observatory, Chicagoⁱ. The seat is held in position simply by the friction of

Fig. 124.

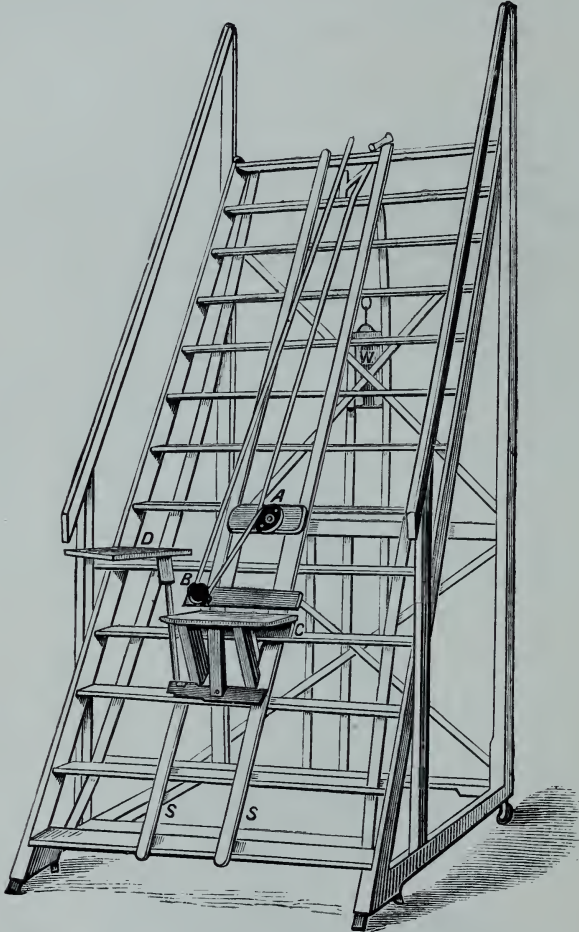

OBSERVATORY LADDER AT THE DEARBORN OBSERVATORY, CHICAGO.

the cord around the fixed drum A. B is a pulley through which the cord runs. At the top of the ladder is another pulley, not shown in the engraving. W is a counterpoise weighing

ⁱ *Month. Not.*, vol. xli. p. 310. March 1881.

10 lbs., which combined with the friction of the cord suffices to balance the observer's weight when seated.

A useful observing-chair for Reflecting Telescopes has been invented by Mr. E. B. Knobel^j: it consists of a saddle-shaped

seat, A, attached to a frame sliding freely in grooves, in two stout uprights B B. On the inside of each of the uprights B B, and attached to them, are strong ratchets, shown in the engraving; the seat, which moves independently in the grooves between the uprights, is kept in position between them by two pawls which are attached to the lower part of it: these pawls are connected by levers to the handles C C, and can be released by lifting the handles upwards: in this way the position of the seat can be regulated at pleasure. The observer sits astride on the saddle-shaped seat A; if then he rests his feet on one of the pairs of foot-rests D D and clasps the top rail, taking one end in each hand, and in doing so, raises the handles C C until they are in contact with the upper bar, he will release the pawls to which these handles are connected by

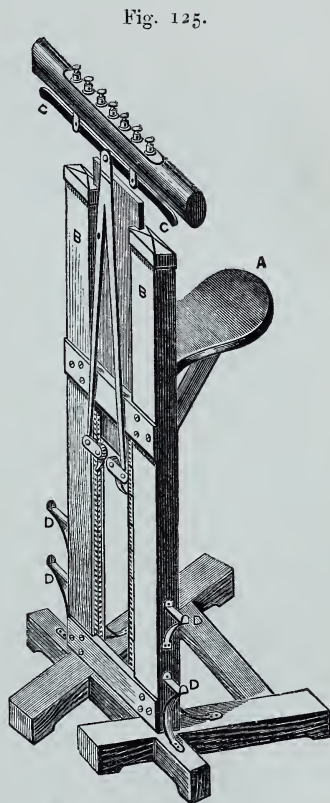

OBSERVATORY CHAIR, DEVISED BY
E. B. KNOBEL.

levers. Now the cross-bar above the handles C C, the sliding-piece between the two uprights, and the seat itself being all connected together, and the weight of the observer being taken off the seat and supported entirely on the foot-rests D D, he can raise or lower it at pleasure as may be convenient. On leaving go of the ends of

^j *Ast. Reg.*, vol. x. p. 96, April 1872; *Month. Not.*, vol. xxxiii. p. 57, Nov. 1872.

the top rail, the handles will fall, and the levers falling with them, the pawls will drop into the ratchets, and secure the seat in the position determined on by the observer. The triangular arrangement of the base renders the seat quite steady, and safe at its greatest elevation. The top of the rail may be used to hold a row of eye-pieces as shown.

METEOROLOGICAL INSTRUMENTS.

Although an astronomical observatory is one thing and a meteorological observatory is altogether another thing, yet every astronomical establishment should be provided with a few of the more ordinary meteorological instruments, even though their owner does not profess to be a meteorologist. All astronomical observations are in a measure affected by changes in the temperature and humidity of the air; consequently, a self-registering maximum-and-minimum thermometer, a hygrometer, and a rain-gauge should be regarded as indispensable accessories to every observatory. No doubt, also, the desirability of having a barometer will naturally suggest itself, though its astronomical usefulness is very small indeed—by which I mean that changes of pressure only require to be taken account of in the very exact instrumental observations carried out in first-class observatories^k. It is also important that a respectable weathercock should be in sight, for the direction of the wind exercises, as is well known, a potent influence on the condition of the air, as revealed by the scrutiny of a celestial object through a telescope.

A good “Six’s” thermometer is quite good enough for general purposes, although not a self-registering instrument of the highest scientific precision. As a hygrometer, “Mason’s wet-and-dry-bulb” instrument leaves nothing to be desired.

The one special precaution of a meteorological character to be taken in connection with all astronomical observations, whether made in an observatory or in the open air, is that equality of

^k Barometric changes effect the rate of an astronomical clock by varying the effect on the pendulum of the resistance

of the air. It is for this reason that sometimes the cases of clocks in large observatories are made air-tight.

temperature should be secured everywhere. Whilst the due ventilation of the observatory should at all times be provided for, it is absolutely essential, in order to insure good results with every kind of instrument, that all doors and windows should be thrown open, so as to obtain a free current of air everywhere for fully half an hour before observations are to be begun; in hot summer weather, indeed, a longer time will generally be found necessary. The object of these precautions is obvious enough: it is to insure the inside air and the metal of the instruments being cooled down (or, as it may sometimes happen, being warmed up) to the temperature of the external air. In order to learn whether this equality exists, every observatory should have a thermometer outside as well as inside. The former should be hung on the north side, away from the Sun, and, if possible, not actually in contact with the observatory itself.

PLANS AND SPECIFICATIONS FOR A SMALL OBSERVATORY.

The following directions and measurements¹, with the plans that accompany them, will enable any builder of ordinary intelligence to construct an observatory.

The first design is for a small observatory suitable for a small Equatorial, say of 6^{ft} or 8^{ft} focal length, and a transit instrument to match. The dimensions given can be easily enlarged or reduced, but it is to be borne in mind that too much floor-space in an observatory is always preferable to too little. Moreover, it is a common practice with amateur astronomers soon to wish to change an Equatorial which they start with for a larger one.

The form which is easiest to construct is a cube with a revolving dome (or its equivalent) on the top. The building now contemplated is 10^{ft} square and 7^{ft} high, framed together as shown. (See Plate XXVII).

The floor is laid on flooring joists which themselves rest on

¹ Specially prepared for this work by Mr. F. Brodie, F.R.A.S., and by Mr. T. R. Clapham. The plan (Plate XXVII) which belongs to this description will be found loose in a pocket at the end of the

volume. It is drawn to scale and can be put into any carpenter's hands. It is erroneously numbered "XVII" instead of XXVII.

the lower cill-plate, which in turn is bedded on a dwarf wall of 9ⁱⁿ brick-work rising, say, 12ⁱⁿ above the ground, the floor to be of 1ⁱⁿ floor-boards at the least, grooved and tongued. Some air-bricks must also be inserted in the 9ⁱⁿ wall. If the floor is thus formed it will be most workmanlike, but apertures or gratings must be provided for ventilation, say 2. If the tongues are omitted the ventilators may be omitted also, because the eventual shrinkage of the floor-boards will probably result in the joints opening, and more than enough ventilation being produced.

A wooden floor may indeed be dispensed with altogether, and there are advantages in this if the soil is a damp one. In this case fill up the area inside the dwarf walls with some such dry material as brick rubbish or broken stone, and cover this with concrete and cement. If the cold surface of this is deemed objectionable in cold weather, some matting or carpet may be laid down, though in general this is unsatisfactory because it harbours dust.

The outside boarding should be brought down for an inch or more below the level of the top of the dwarf wall: this will prevent the rain effecting a lodgement and rotting the lower plate. Braces as shown are useful to give stiffness to the framework when the dome is being turned round.

This square building is to be placed so that its corners face the 4 cardinal points. The transit pillar is placed in the S. corner, and all 4 corners are splayed off in order that the frame which carries the shutters of the dome may be free to move round all points of the compass. A transit instrument mounted in the position and under the circumstances described will command an arc of the meridian from the S. horizon to a little beyond the zenith, say 100° in all, which is more than sufficient when the instrument is only required for setting a clock.

The shutters of the dome open by sliding on runners which project downwards and beyond the dome, hence the necessity for the top corners of the cube to be splayed off. Across these corners a tie-piece is mortised to the top frame, making that frame octagonal. This serves to give stiffness to the frame (see

Plate XXVII, Fig. A). The upper plate is hollowed out and lined with sheet zinc as a channel for the balls which support the dome to run in. The outer edge is also enclosed with a band of sheet zinc which rises nearly to the top of the balls. The cill of the dome being also provided with a similar band which comes down outside the fixed band, the overlapping of the one zinc band by the other secures, or should secure, the exclusion of rain from the balls and the channel in which they run. The plate which carries the channel in which the balls supporting the dome run may be cut out of the solid, it having a good bearing all round on the top of the frame; but the cill of the dome itself, which runs on 3 or more balls, is constantly being strained when the dome is turned round, and therefore special provision must be made for giving it both strength and rigidity. This is best done by making it of 5 or 6 layers of 1ⁱⁿ boarding cut in segments and glued together, the joints of each one of the 5 or 6 rings thus superposed breaking joint with the ring on either side of it until the desired thickness is arrived at by the requisite number of rings. On the inside of the composite ring thus built up a band of sheet iron may be fastened to give further stiffness, as shown in the plan. On the under side of this cill 2 concentric rings of iron are fixed by means of screws passing through them. The holes for the screws must be countersunk. These rings should be of carefully forged or, better still, of rolled iron, about 1ⁱⁿ wide and $\frac{1}{2}$ ⁱⁿ thick. The central point between these 2 rings and the central point of the hollow channel in the upper plate of the main building must coincide exactly; that is to say, must be circumferences of circles of absolutely identical radius, or great and unnecessary friction will be found to exist when the dome comes to be turned round. It is this part of the whole observatory which most requires careful setting out and good workmanship, and if these are obtained it will be found that when the balls are put in their channels (at 120° apart where there are 3 of them) and the dome is lowered on to the balls the dome will move with very little friction, and will rest very steady on its bearings even in a gale of wind.

The way to frame the (so-called) dome will be better understood from the plan than by any particular description.

The top shutter of the dome runs on wooden bars back beyond the zenith so as to leave the zenith clear for the telescope. This shutter has small brass runners inserted on the under-side at about 10ⁱⁿ or 12ⁱⁿ apart. If each wooden bar has a strip of zinc or thin hoop iron neatly fixed on its upper edge, the brass runners will move more smoothly than they will do when running upon wood. This shutter is opened by means of a rope fixed to its *front* edge and running through pulleys fixed inside the dome, one at the top and one on the cill or near the bottom of the dome on the opposite side to the shutter. This rope therefore being inside the dome is protected from the weather, and revolves with it and out of the way. This rope, in *one length*, is continued again across the observatory (hanging loose in the air) up to the top of the dome alongside the sloping shutter, to the *back end* of the top shutter, and thus is available for pulling the top shutter *forwards*. When work is going on in the observatory it will be inconvenient to have this rope swinging about, so a hook must be provided in some convenient position to loop it up to. When this shutter is shut, then the side shutter is pulled close up to it, under its front edge, and a weather-proof joint is so formed.

The side shutter of the dome runs in a groove formed by 2 strips of flat iron about 1ⁱⁿ thick, and fixed to wooden runners, which in turn are fixed to the dome, one on either side of the opening and projecting downwards over the side of the building as shown. This shutter is also provided with brass wheel runners both on its under side near each corner as well as at each corner of the edge. If these runners are carefully fixed and of good make, the shutter should slide up and down with perfect ease. This shutter is raised by ropes attached, one on each side near the top, which are led along the top of the dome down again on the opposite side close to where the rope of the top shutter is. To the end of each rope is attached a small leather bag containing a few pounds of shot. These bags must

be weighted to counterbalance the shutter, so that when opened it will remain in equilibrium at any part of its run.

The transit shutter is made and slides in a similar way. It may be entirely covered with zinc, as shown, which turned over at the sides will make the joints water-tight. The top of this shutter should be fitted to run up just under a cross piece of wood to exclude water from entering at the top. This shutter being so much smaller and lighter than the dome shutter, needs only a single rope fixed in its centre at the bottom and running over a small pulley fixed at the bottom of the shutter opening, with a small lead weight as a counterbalance.

The top shutter is to be covered with canvas well painted, and if the observatory should be in an exposed position and rain should beat in underneath the sides of the shutter, a strip of wood should be placed outside the flanges of the shutter. Let these stand up nearly as high as the top surface of the shutter, by way of forming a sort of channel for the shutter flanges to run in. A piece of Hartley's glass let into one of the shutters is useful for giving light in the observatory in the day-time in bad weather; for windows in the sides of the building do not always admit sufficient light to enable the upper parts of the Equatorial to be well seen for cleaning purposes.

The covering of the observatory may be of various materials, dependent upon the permanency desired and the expense which the owner is willing to incur. The simplest is tarred felt, such as is commonly used for roofing purposes, nailed on to the framework. This felt may be made water-tight, and with care and attention will last for several years. However, deal boards are much to be preferred, and are worth the extra cost. In either case, however, all angles and the flat portions of the roof must be covered with canvas, first stretched on, and then painted with at least 4 coats of good oil-paint.

If boarding be employed, then the boards should be $\frac{3}{4}$ in thick, grooved and tongued, with the joints placed perpendicularly all round; and where the corners are splayed off they should be covered with painted canvas.

For covering the dome $\frac{1}{2}$ ⁱⁿ match-board should be used. This also must itself be covered with canvas well painted.

Sheet copper or zinc may also be used for the dome. This may be of the ordinary roofing thickness, or even thinner. The pieces must be cut into sectors to fit the sides of the dome. Each piece is to be fastened at top and bottom with zinc nails, but the sides must be counter-lapped (not soldered) in order to allow of expansion. A pattern for the sectors must be cut out in brown paper after the frame of the dome has been put together.

The sizes of the quarterings for the framework may be as follows:—For the corner uprights $3\frac{1}{2}$ ⁱⁿ \times $3\frac{1}{2}$ ⁱⁿ; for the upper and lower plates, 3 ⁱⁿ \times $4\frac{1}{2}$ ⁱⁿ: for the other uprights and braces, 2 ⁱⁿ \times $3\frac{1}{2}$ ⁱⁿ.

It will be useful to give some information respecting the cost of an observatory of the kind just described.

In 1865 I had one made by a country builder in Sussex according to plans almost identical with those which appear on Plate XXVII. The details were as follows:—

	£	s.	d.
Woodwork, including glass, ironmongery, and 2 coats of paint ...	48	12	7
2 wrought-iron rings for dome	3	10	0
8 cast-iron segments to form channel plates, including filing and fitting	4	0	0
3 cast-iron balls	0	6	4
Carpenter's time packing for rail, and unpacking and fixing in Kent ...	1	4	9
	<u>57</u>	<u>13</u>	<u>8</u>

* * This does not include the brick-wall 2^{ft} high on which the observatory was fixed, nor the brickwork and stone-caps of the equatorial pier and entrance steps. Say 3*l.* for this additional work.

In 1868 I had another 10^{ft} dome made for use on the tower of a dwelling-house at Bickley. This with its 2 iron rings and channel plates cost 30*l.* 18*s.* 11*d.* In 1874 this dome was taken to pieces and sent by rail to East-Bourne, where it was re-erected on the tower of another house, as shown in Fig. 127 to be explained directly.

The cost of the tower was reckoned in the builder's contract for the house, and no separate items can now be given. It may

be a material point however to add that this dome is now (1889), after 21 years' exposure to wind and weather, as sound and water-tight as on the day it was finished, and beyond regular painting every 2nd or 3rd year, nothing has been done to it in the way of repairs except that the lid has been covered on the outside with sheet-lead, partly to weight it down and prevent high winds from raising it at any time that it may be left unfastened inside.

Fig. 127.



NORTHFIELD GRANGE, EAST-BOURNE: EXAMPLE OF AN OBSERVATORY
BUILT AS PART OF A DWELLING-HOUSE.

Fig. 127 may now be considered in connection with the specification given on p. 221, *et seq.* It represents the adaptation of the principles embodied in the specification to the circumstances and conditions of a private house. For reasons which may be said to be obvious, the timber-framing and boarded sides of the Equatorial room are replaced by brickwork, but the dimensions and general features of the most important part of

the structure—the moveable roof or “dome”—are the same in both cases; and only a few lines of explanation are needed to deal with the differences between the two.

When the bricklayers had reached in the ordinary course of building the level of the floor of the observing room their operations were stopped for the insertion of a pair of iron girders of the ordinary double T shape about 11^{ft} 6ⁱⁿ long. These were braced together with nuts and bolts so as to be 18ⁱⁿ apart. Thus prepared they were bedded at each end on pieces of lead laid on felt, to lessen as far as possible the transmission of tremor. The brickwork was then resumed, care being taken by means of a slab of stone placed over the ends of the girders that no part of the brickwork was allowed anywhere to come in contact with any part of the girders. The brickwork was then carried up to a height of 6^{ft} 6ⁱⁿ above the floor of the Equatorial room, and at that height received the plate corresponding to the plate marked in Fig. E in the plan referred to already. (Plate XXVII.) The girders were widened out on their under-sides in the mid-interval of their length so as nearly to meet, and the metal stage thus obtained served to take a part of the foundations, and therefore a part of the weight of the brickwork-base constructed to carry the iron pillar of the Equatorial.

As the house was built to face the 4 points of the compass the Transit instrument with its window was necessarily placed in the middle of the South wall of the tower, at some slight sacrifice of floor-space, but this is not found productive of any great inconvenience, because the step down below the floor-level providing leg-space for the observer using the Transit instrument is made good by a board which can be placed flush with the main floor when access to the Transit instrument is not desired.

A sidereal clock of the usual pattern stands on a stone shelf in the S.W. corner of the room. The S.E. corner is occupied by a triangular table with shelf over.

The access to the room is by an ordinary staircase opening through the floor, which opening is closed by a flap when the Equatorial is not in use. An inspection of Fig. 127 in the light

of the detailed information supplied by the lithograph plan will render further verbal description unnecessary here.

An observatory need not be very substantial, and provided that it is capable of resisting the storms that may beat upon it, the thinner it is, the better it will enable the telescope contained

Fig. 129.

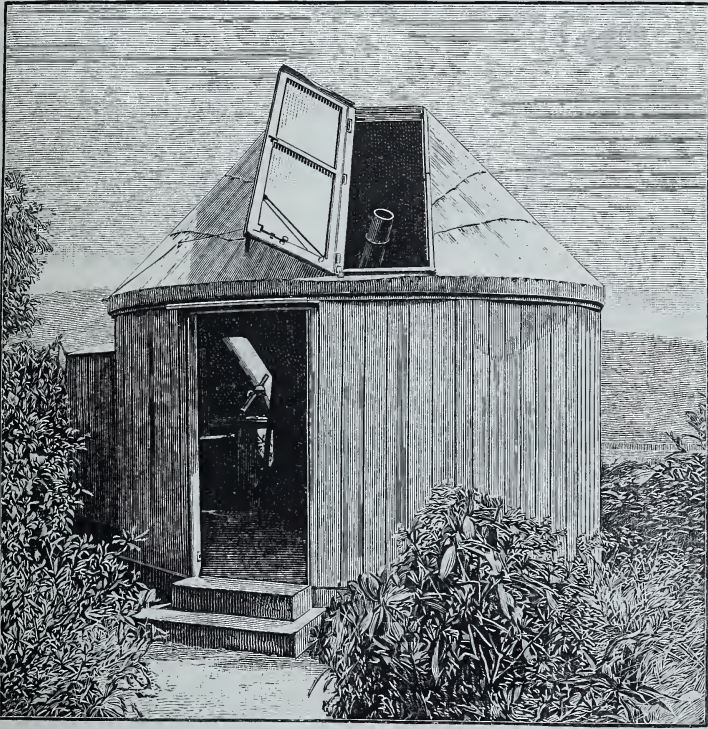

THE OBSERVATORY AT AUSTWICK HALL, W. YORKSHIRE. "ROMSEY TYPE."

in it to fulfil its functions. Wherefore it will be useful to direct attention to a cheap and popular form of observatory planned by the Rev. E. L. Berthon, Vicar of Romsey¹. The "Romsey Observatory" was the first of a great many which have been erected on the like model and with uniform success. This form of observatory is becoming increasingly popular with

¹ Mr. Berthon's own description of his Observatory will be found in *Eng. Mech.*,

vol. xiv. p. 83, Oct. 13, 1871. His estimate of cost is from 8*l.* to 12*l.*

amateurs as a building thoroughly useful and capable of being constructed at a very moderate cost.

The one of which the following is a description is amply large enough for a telescope 6^{ft} 6ⁱⁿ in length over all. (Plate XXVIII.)^m

When the site has been selected, first dig out the foundations for the pier of the Equatorial. This, where possible, should be on solid rock. If such is not attainable, a good thick slab of stone should be carefully bedded on the best sub-soil available and upon this the pier built. This should not be carried higher at first than about 1^{ft} above the ground level. Procure a straight rod rather more than 6^{ft} long, and drive into it a long French nail exactly 6^{ft} from one end; this rod is to be used as a radius bar by which to set out the dwarf wall A which supports the floor joists. (Fig. B.) The rod is also to be used to adjust in their places the posts *b* and the wall-plate of the observatory. On the centre of the base of the equatorial pier, which is of hewn stone 16ⁱⁿ square and must face true N. and S., place the pin of the radius bar and describe on the ground a circle 12^{ft} in diameter, driving in wooden pegs about a foot apart; pass a string round these, and the bricklayer has a good outline for the dwarf wall A, which must be carried up about 6ⁱⁿ above the ground level; this wall need not be more than 9ⁱⁿ thick. Upon this are placed the floor joists, 6ⁱⁿ × 3ⁱⁿ, and laid 12ⁱⁿ apart, the two first being laid about 2ⁱⁿ from the side of the central pier. Air-holes (say 4 at equal distances) must be left in the wall for ventilating the underside of the floor. The floor is made of good pine boards 1ⁱⁿ thick, care being taken to allow a space of half an inch between the boards and the sides of the piers of the Equatorial and Transit instruments. When the floor has been laid, describe upon it, with the centre of the pier as a centre, a circle exactly 12^{ft} in diameter. Divide the circumference of this into 12 equal parts, and at each of these 12 points erect a strong post *b*, 6^{ft} high and 3 $\frac{3}{4}$ ⁱⁿ square; the bottom end of each is to be let into the floor about $\frac{1}{4}$ ⁱⁿ and bedded in white

^m The plan (Plate XXVIII), specially prepared for this work by Mr. T. R. Clapham, will be found loose in a pocket at the end of this volume.

lead. Take care that the centre of the space between two of them faces S.; and then the two opposite posts will be available as a doorway, facing N. (Fig. A.) These posts, which are cut out of 4ⁱⁿ plank planed up, are braced together in pairs by bars *c*, 3ⁱⁿ × 2ⁱⁿ, the topmost bar being flush with the top of the posts, the second bar 3^{ft} from the floor. At the bottom and on the floor itself there is a sole piece 2ⁱⁿ × 1½ⁱⁿ. To these three bars are nailed vertically the boards *d*, which form the walls of the building.

Out of well-seasoned 1ⁱⁿ pine cut 14 segments to form a ring whose internal diameter shall be 11^{ft} 3ⁱⁿ, and external diameter 12^{ft}.

Lay these segments down on a level floor, taking care that the outer edges of the segments correspond accurately with the line of a 12^{ft} circle marked on the floor and to be used as a gauge. Cut another set of segments and lay them on the first set in such a way that the centre of each upper segment may be over the joints of those below; the two rings thus formed must be securely *screwed* together, as upon the rigidity of the compound ring thus created depends in no small degree the easy and convenient working of the domeⁿ. This ring, to be used as a wall-plate *e*, is to be fastened down on to the posts *b*, by 6-inch screws put into each post, care being taken that the outer edge of the circle corresponds with the outer edge of the posts. The walls of the observatory are to be constructed of *well-seasoned* 1ⁱⁿ pine boards 6ⁱⁿ wide, *d*, grooved and tongued, each piece being cut precisely to the right length for fitting exactly between the under side of the wall-plate and the floor. Each board must be well "crabbed home" before being nailed to the cross bars *c*. When all the boards are secured in their places and the wall therefore complete, the ends of the floor boards must be trimmed and skirting boards 6ⁱⁿ deep nailed all round. This covers the ends of the floor boards and the ends of the joists and forms an edge to which the outside of the dwarf wall A may be made good in Portland cement.

ⁿ Where a little extra trouble and expense is not of moment it will often be advantageous to construct the ring of 3 sets of boards.

On the top of the wall ring (constructed and fixed as above mentioned) 12 strong iron sash rollers, *f*, are to be screwed, one over each post. The rollers are to be $1\frac{3}{4}$ in diameter, and $1\frac{1}{2}$ in broad. The dome rests upon these; and an air space of $1\frac{1}{2}$ in for ventilation is obtained at the same time. To the top of every alternate post is firmly screwed a piece of wood 1ft long, 3in wide, and 2in thick, to which is fastened a sash-roller like those just mentioned, but with its axis vertical (see Plate XXVIII, Fig. C); these work against the inner edge of the ring of the dome and act as friction rollers and guides, and keep the dome in its place.

The first thing to be done towards constructing the dome is to make a ring 12ft 2in in exterior diameter. Proceed exactly as in making the wall-plate, but the segments must be $5\frac{1}{2}$ in wide instead of $4\frac{1}{2}$ in, and greater rigidity will be obtained by having 4 rings superposed to form the compound ring, instead of 3.

The *inner* edge of the ring must be of exactly the same diameter as the inner edge of the wall-plate. When the ring is finished, a corresponding set of segments of stout galvanised iron or zinc, to form a ring of the same width and diameter as the wall-plate, must be fastened by screws to the underside of the dome ring, the heads of the screws being counter sunk. This metal lining forms a friction plate for the rollers to work against, and prevents them wearing into the underside of the dome ring, which they would otherwise soon do. The ring being thus finished is ready to receive the rafters. At two opposite points on the upper side of the dome ring fasten two rafters *g, g*, each 6ft 1in long and $2\frac{1}{2}$ in \times $1\frac{1}{2}$ in (the measures of these rafters are taken from the centre of bevel), the other ends being fixed to the ridge-piece *h*, 4ft long and $2\frac{3}{4}$ in \times $2\frac{3}{4}$ in. The upper side of the ridge-piece will be 11ft from the floor. On each side of this ridge-piece are fastened 3 rafters, *i, i, i*, each 7ft 6in long and $2\frac{1}{2}$ in \times $1\frac{1}{4}$ in, the lower ends resting on the dome ring. Two rafters *j, j*, on one side of the ridge, are to be 1in deeper and 1in thicker than the others, and so placed as to allow a clear space of 21in between them; this forms the

shutter-opening, and to one of these rafters the shutter-frame is fixed by 3 stout 4ⁱⁿ "butt" hinges. The object of having these two rafters of extra depth is, that they may form a "combing" 1ⁱⁿ above the roof for the shutter-frame to rest upon, thereby preventing rain being driven into the observatory. The dome is further strengthened by rafters of varying length, as will be seen by consulting the plan, from which the dimensions can be taken, as it is drawn to scale as indicated. With the exception of the shutter-rafters *j, j*, and the ridge-piece *k*, all the rafters are dressed to 2½ⁱⁿ × 1¼ⁱⁿ. When this framework is put together complete (and for this, *brass* screws are recommended), it must be covered with good stout canvas, either light sail cloth or tarpauling nailed to the rafters with copper tacks; the canvas may either be cut into gores, each gore being nailed on separately, or (and this is a preferable plan), start at the bottom of the dome and fix one width of canvas all round the roof, neatly pleating in gores as required: then lay on the next length with a good overlap, and so on till the whole frame is covered. In either case the canvas must be stretched as tight as possible before it is nailed down to the rafters. The canvas for the shutter-frame should project well over the edges of the combing to diminish the chances of rain being driven in. When the canvas has been firmly fixed and finished off, the whole should receive two coats of boiled linseed oil, and when this is dry two coats of Carson's outside paint should be applied. The observatory of which this is a description was so treated, and at the end of 5 years was as perfectly watertight as on the day it was finished. A strip of zinc 4ⁱⁿ wide, *k*, is nailed all round the edge of the dome ring and covers the space between it and the wall-plate; this zinc acts as a guard to prevent snow and rain from driving in. On the rafter next to that to which the shutter is hinged are screwed two pieces of flat iron bar bent to two right angles and standing 1^{ft} high, *l, l*. These support the shutter when open. A light iron rod, *m*, fastened by a staple to the middle of the shutter-frame, the other end resting on a small brass hook, enables the shutter to be closed from the inside. The following is a simple

expedient for fastening the shutter down:—Let a blacksmith make a $\frac{3}{8}$ in square iron rod 5^{ft} long with a crank at one end and another crank halfway down; fasten this by square staples to the side of the shutter-rafter, the cranks slotting into corresponding staples on the shutter-frame. Such a rod can be kept in position by a button-stop screwed to the rafter about an inch from the bottom of the rod, a separate slot-bolt being fastened to the bottom of the shutter-frame (see Fig. D). A good stout handle similar to that of an ordinary thumb-latch should be screwed to the lower edge of the rafter on to which the shutter closes (*n*, Fig. E) for use when it is desired to pull or push the dome round from the inside.

Should the observatory be in an exposed position and with a likelihood of the dome being lifted during a heavy gale, three iron catches (Fig. F) should be fixed at equal distances inside the observatory. The middle part of each catch is jointed; the upper end clasps and is made fast by a pin to one of the rafters; whilst the lower end slips on to a staple fixed in one of the bars. When not in use, the catch can be turned up out of the way of the stops (Fig. C) and held there by a simple wire loop.

A guy cord should be attached to a ring about the middle of the outer shutter-frame and be led through a small eyebolt on one of the rafters, to a cleat on the edge of the dome ring, where the other end must be *made fast*. This cord is useful in case the shutter has to be opened in a strong wind.

The details of the cost of the Austwick Hall Observatory are as follows:—

	£	s.	d.
Timber-framing and boards, best red deal	15	4	2
13 lbs. zinc	0	4	4
Erecting observatory, carpenter 126 hours, apprentice 75 hours	4	11	10
Mason, building 2 piers	2	9	0
Canvas for roof, and copper tacks	1	9	2
Smith's work	0	5	6
Linseed oil, paint, and varnish	1	10	0
	25	14	0

* * This does not include labour for painting and varnishing, which was done by the owner himself.

Fig. 130.

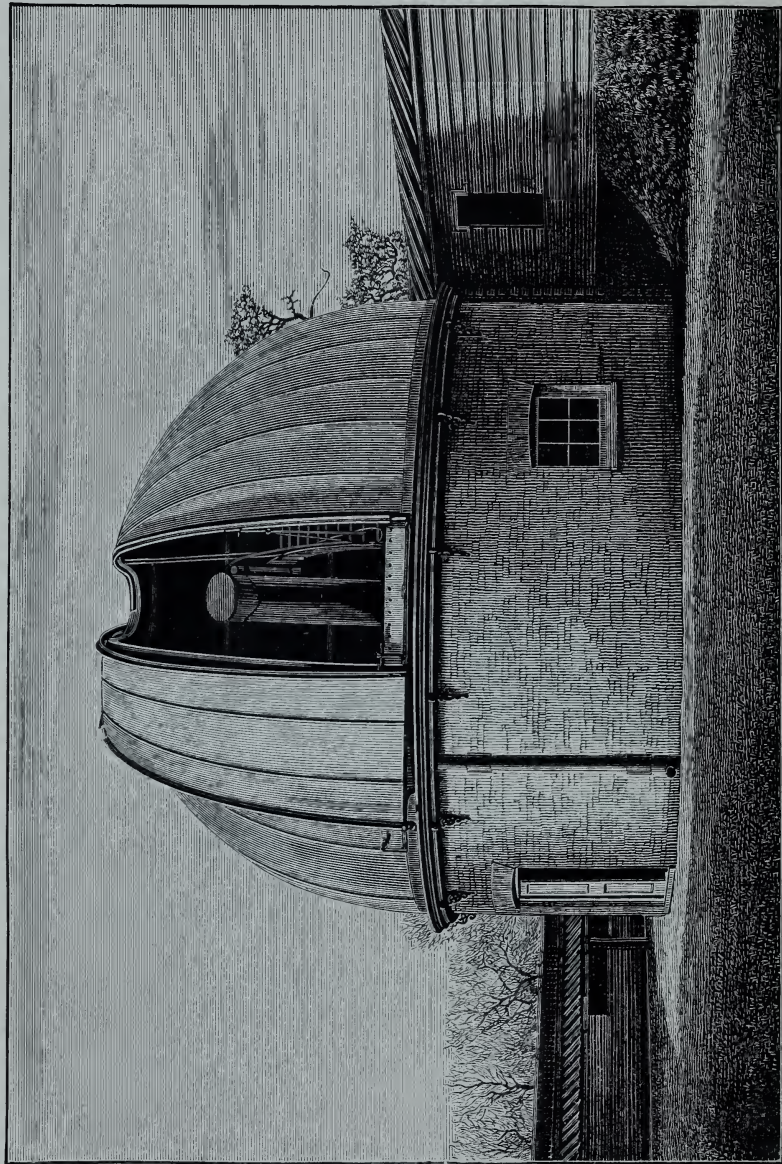

THE 30-FEET LASSELL DOME AT THE ROYAL OBSERVATORY, GREENWICH.

IMPORTANT OBSERVATORIES.

Plate XXIX. is a view of the dome recently erected at Greenwich to receive the reflector presented to the observatory by the late Mr. Lassell. This instrument need not be further described here, but the dome, 30^{ft} in diameter and constructed by Cooke & Sons of York, may be regarded as one of the most perfect of its kind yet made, representing as it does all the newest mechanical expedients to combine efficiency of protection to the instrument with facility for use and movement.

The Washburn Observatory is interesting as representing a two-fold idea, which is thoroughly American in its practical aspects, and for which we have unfortunately very little counterpart on this side of the Atlantic—the building and equipping of large collegiate observatories by the munificence of private citizens, and their adaptation for star-gazing purposes for the benefit of students and the general public. This observatory was built and presented to the University of Wisconsin in 1878 by the late C. C. Washburn, ex-Governor of the State. The accompanying view represents its eastern front, which contains the library and offices to the observatory. Between these and the dome are a corridor and a clock-room containing a sidereal and two mean-time clocks, from which time-signals are furnished to the railway systems of Wisconsin and the surrounding States. Under the dome there is a 15½ⁱⁿ refractor by Alvan Clark, with all the usual accessories. Beyond the dome, and not shown in the illustration, is the meridian-circle room, which contains a circle of the type represented in the *Encyclopædia Britannica*, constructed by Repsold, with a 4.8ⁱⁿ object-glass by Clark.

The large Equatorial and the Meridian Circle are the principal instruments of the observatory, and most of its working force is expended upon them, but the “Student’s Observatory” shown in the right of the engraving contains some excellent smaller instruments. The dome covers a 6ⁱⁿ Clark Equatorial, with which the earlier double-star work of Mr. S. W. Burnham was done, and whose optical qualities are sufficiently shown by that

work. It has been provided with a new mounting, and with a system of mirrors in front of its object-glass to adapt it to the methods of research recently proposed by M. Löwy. Beyond the dome of the Student's Observatory, and partly hidden by it, is the Transit room, containing a combined Transit instrument

Fig. 131.

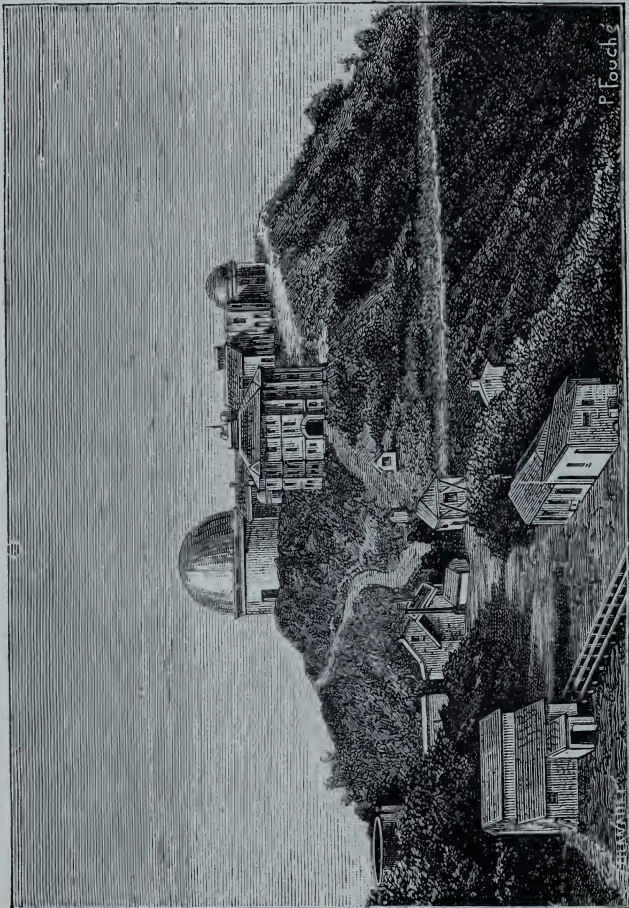

N. E. VIEW OF THE LICK OBSERVATORY ON MOUNT HAMILTON, CALIFORNIA, U.S.

and Zenith telescope of 3ⁱⁿ aperture by Fauth; an excellent instrument, which is devoted in part to work of instruction and in part to maintaining the time-service of the observatory.

Fig. 131 will interest the reader as representing the largest observatory with the largest telescope in the world. It would

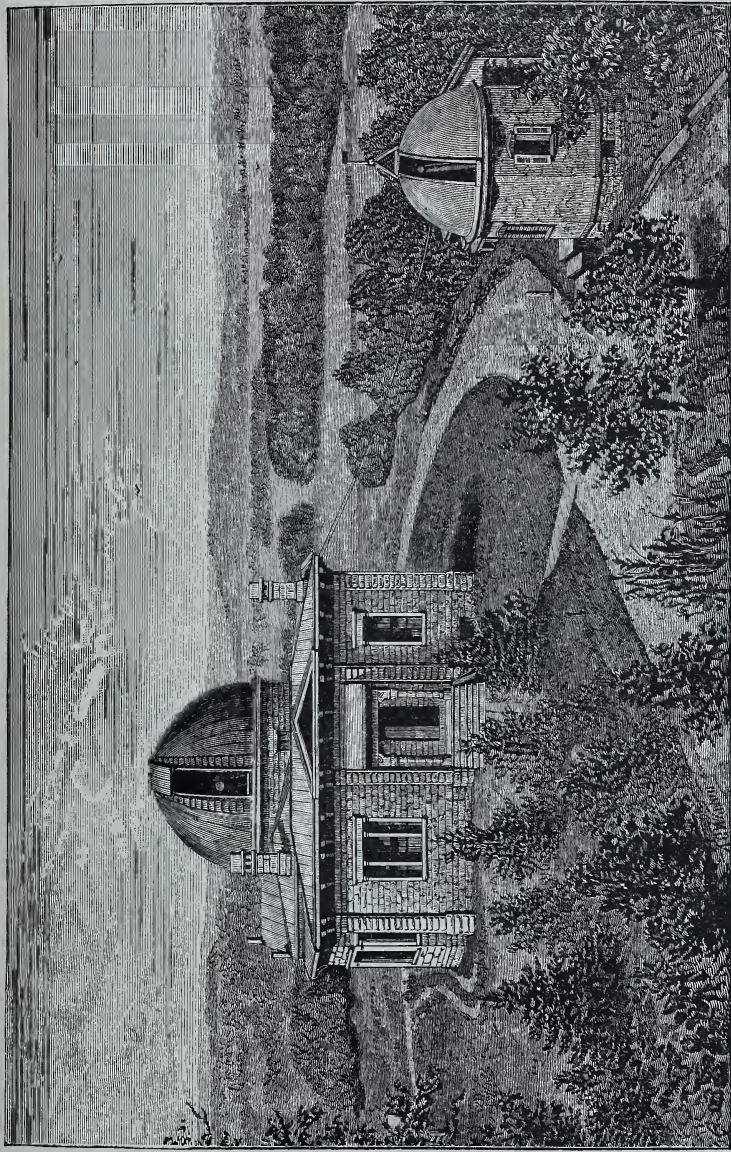

GENERAL VIEW OF THE WASHBURN OBSERVATORY, MADISON, WISCONSIN, U.S.

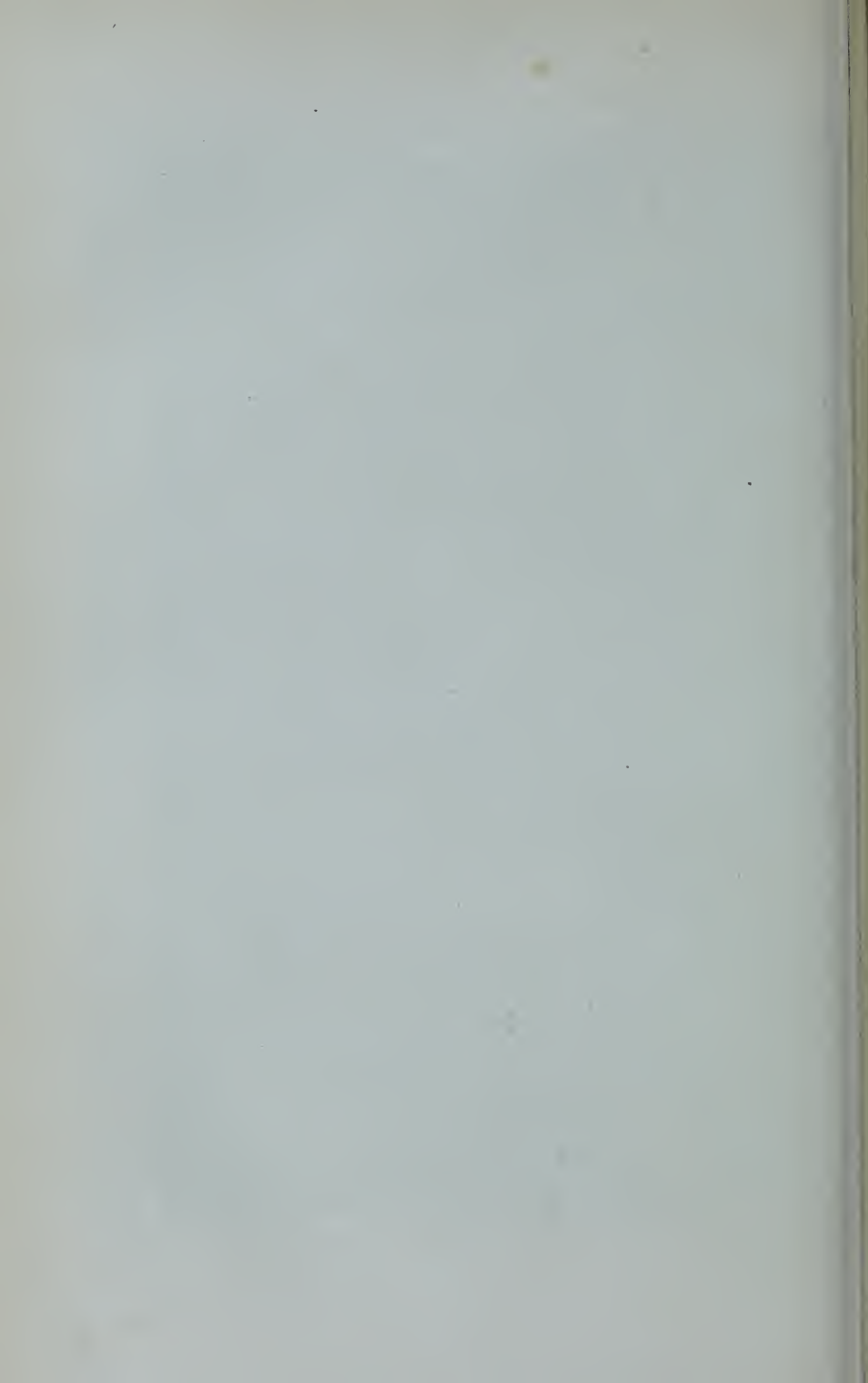

seem that the great establishment on Mount Hamilton is, and from the first has been, free of all imputations of "tall-talk," and that it has been built and furnished with the sole desire of doing the best possible work in the best possible way. It would be foreign to the scope of this work to enter into even a general description of the Lick Observatory°, but the external view here given, coupled with the engraving which appears (Fig. 67, Plate XV, *ante*) of the great 36ⁱⁿ Refractor there, will recall to the reader the existence of a newly created centre of work of which great things may be expected.

° For a general description of the Lick Observatory, see Holden's *Handbook of the Lick Observatory*, 16mo. San Fran-

cisco, 1888; also *L'Astronomie*, vol. v. p. 121. April 1886; vol. viii. p. 241, July 1889; vol. viii. p. 305, Aug. 1889.

CHAPTER VIII.

PRACTICAL HINTS ON THE CONDUCT OF ASTRONOMICAL OBSERVATIONS.

On the choice of Instruments.—Eye-pieces.—Areas of Object-glasses and Mirrors.—On cleaning Lenses and Mirrors.—On the choice of stands.—Clockwork.—The Parallaxic Ladder.—Observing-box.—Steinheil's Transit Prism.—Sidereal Time Indicator.—Useful Books.—How to observe the Sun.—The Moon.—The Planets.—Sweeping for Objects.—Comets, Clusters, and Nebulæ.—Drawing nebulæ—Stars, including Double Stars.—Triangular Star Discs.—Observations of Stars for colour.—Magnitudes of Stars.—Observations of Variable Stars.—Miscellaneous Hints.—Lights in an Observatory.—Clothing for an Observer.—Number of nights available in a year.—Aperture of Object-glass may sometimes be reduced with advantage.—Forms to facilitate work at the Telescope.—Hints by Admiral Smyth.

THE present chapter must be regarded as made up of waifs and strays collected from a great variety of sources, and thrown together without much order or method.

ON THE CHOICE OF INSTRUMENTS AND THEIR ACCESSORIES.

Always prefer a refracting to a reflecting telescope. Refractors are far more manageable than reflectors, and less liable to suffer from neglect or inexperience, though it must be admitted that, aperture for aperture, the latter are much cheaper^a.

^a An interesting paper describing Comparison Experiments by C. E. Burton, will be found in *Ast. Reg.*, vol. x. p. 289. Dec. 1872. See also a paper entitled *A photometric comparison of Reflecting and Refracting Telescopes* by Professor Pritchard (*Month Not.*, vol. xlv. Nov. 1884) and the discussion thereon (*Ast.*

Reg., vol. xxii. p. 282): also letter by N. E. Green, *Ast. Reg.*, vol. xxii. p. 308. Green's conclusions are that as regards light it only requires 5 or 6 inches of reflector in aperture to be equal to 4 inches of refractor, a disparity of slight moment considering the small cost of reflectors compared with refractors.

Though neatness in the metal-work is highly desirable, yet be careful not to think too much of it, for there may be an excellent outward appearance with very slight internal value. The ultimate performance depends not on the polish of your tubes, but on the accuracy of your lenses, as regards their figure, centering, &c. Air-bubbles, sand-holes, *stricæ*, scratches, are no doubt undesirable in their way, but do not be troubled too much about them; they are not absolutely inconsistent with good definition; they merely obstruct an infinitesimal amount of light. Remarks on testing object-glasses have already been made in a former chapter (Chap. I., *ante*).

The centering of the lenses should be properly performed by the maker; if, however, he has not attended to this, it is best, unless the inconvenience is very serious, to put up with the evil. An inexperienced hand often not only makes matters worse, but commits irreparable damage.

A dew-cap is always desirable, though not invariably supplied to small telescopes. At night it is needed to protect the object-glass from the aqueous vapour floating about in the air; and in the day-time it serves to lessen the light reflected into the tube by the metal ring in which the object-glass is mounted. Its length should be not less than twice the diameter of the object-glass. The exterior should be polished, the interior blackened "dead" black.

Every telescope of and beyond $2\frac{1}{2}$ in aperture should have a finder, however small; its use saves an incalculable deal of trouble, and prevents much loss of time—an important matter in a climate where clear and astronomically-good skies are rather rare. Especially will the observer, who employs a telescope not equatorially mounted, discover the usefulness of this inexpensive little accessory after a few nights' trial with and without the same. A finder too is very convenient in working with a transit instrument, though not ordinarily applied thereto. Its employment tends to guard the observer against surprises, and against the consequences of error in the setting of his circle.

As regards powers—the common idea generally encourages a number that is excessive. Without attempting to lay down any stringent rules^b, the following lists (based for the most part on giving one eye-piece for each inch of aperture) are offered in the belief that most amateurs will find them amply adequate:—

APERTURES OF—

2 in.	3 in.	4 in.	5 in.	6 in.	7 in.	8 in.	9 in.	10 in.
15	20	25	30	35	40	50	60	75
45	55	65	85	85	95	110	130	150
100	110	140	170	160	170	200	200	240
	200	300	280	250	260	300	300	350
			420	360	390	410	410	470
				500	500	530	530	590
					680	660	670	710
						800	810	840
							950	980
								1140

The highest powers must be reserved for the examination of close double stars on peculiarly good nights, and with clockwork motion. Burnham recommends all eye-pieces being fitted so as to be “self-focussing.” That is to say that by metal stops it should be arranged that directly they are pushed “home” they should be in focus. His procedure is as follows:—Select a good night and a close and difficult double star; focus very carefully your highest power. Then replace it by the next lower power, pushing this into the draw-tube and bringing it to focus *without moving the draw-tube*: make a mark on the eye-piece at the draw-tube, and so with each eye-piece in succession. Fit on to each a narrow ring of tin or other metal, leaving the ring somewhat wider at 2 opposite points than the distance between the original shoulder of the eye-piece and the mark. File down these projections gradually till the point of clearest vision is reached. A few trials will suffice. It is true that different conditions of air and eye affect the focus of eye-pieces, but Burnham asserts that the differences are less, really, than is

^b Pogson has pointed out that for an optical reason depending on the average diameter of the pupil of the eye, the

lowest available power is 5 times the aperture of the telescope in inches.

usually supposed, and that a trifling adjustment of the draw-tube for the improved focus of one eye-piece will carry with it the necessary rectification for all of a series prepared as above, if the fitting has been carefully performed.

Accuracy in focussing is an important matter. Holden says that a cluster of stars close together, and of magnitudes which differ considerably *inter se*, yields the best test of accurate focal adjustment. The eye is sensitive to the very least change or inexactitude in the focussing of such an object; but in the case of a double star (often recommended for focussing purposes) there is a certain though small range of inaccuracy which the eye will tolerate no matter how difficult the double star may be. Professor Phelps concurs in this practical hint.

The highest power which a good refractor can possibly be expected to carry under the most favourable circumstances may be ascertained roughly by *multiplying its aperture in inches by 100*. Example:—What is the highest power that can fairly be used on a telescope of $4\frac{1}{8}$ ⁱⁿ aperture? Here $4\frac{1}{8} \times 100 = 412$. It need hardly be said that this rule must be accepted subject to reservations. Rarely in England will it be possible to use so high a power as the rule suggests; occasionally, however, a higher power may be indulged in.

As regards the limits of vision of achromatic telescopes, the following rule will be found nearly correct for Argelander's scale of magnitudes. *Multiply log. of aperture in inches by 5 and add 9.2 to the result*. Example:—What is the smallest star visible in a telescope of 4ⁱⁿ aperture?

Log. 4	=	0.6020600
				5
				3.0103000
Add			9.2
				12.21

Therefore a telescope of 4ⁱⁿ aperture may be expected to show stars of mag. 12, but nothing so small as mag. 13 of Argelander's scale.

Another form of this problem has been presented to me in MS. by Mr. N. Pogson, specially for this work. His rule is:—

Determine by trial the smallest star (Argelander or Radcliffe) which you can see with an aperture of 1ⁱⁿ. Then the limit of vision for any other aperture will be:—

One-inch limit + 5 × log. aperture. He remarks that “The limit for 1ⁱⁿ will differ less than people imagine, averaging about 9 $\frac{1}{4}$.”

For 4 inches of aperture we have the following figures:—

$$9.25 + 5 \times 0.602 = 12.26.$$

This result accords very well with the one given above.

As to the power of small telescopes to show stars of particular magnitude, Flammarion gives the following information, rendered in English measures:—

A telescope of 2 $\frac{1}{4}$ inch aperture will show stars of 8 mag.

”	2 $\frac{3}{4}$	”	”	8 $\frac{1}{2}$	”
”	3	”	”	9	”
”	3 $\frac{3}{4}$	”	”	10	”
”	4 $\frac{1}{4}$	”	”	11	”

Johnson assuming that 1ⁱⁿ of aperture will show steadily a star of 8.1 mag. on a fairly clear night, computed the following table^c:—

Aperture. inch.	Mag.	Aperture. inch.	Mag.
1 =	8.1	7 =	12.6
1 $\frac{1}{2}$ =	9.0	8 =	12.9
2 =	9.7	9 =	13.2
2 $\frac{1}{2}$ =	10.2	10 =	13.4
3 =	10.6	11 =	13.6
3 $\frac{1}{2}$ =	10.9	12 =	13.8
4 =	11.3	13 =	14.0
5 =	11.8	14 =	14.2
6 =	12.2	15 =	14.4

There is greater discrepancy between Flammarion and Johnson herein than was to be expected.

^c *Radcliffe Obs.*, 1851, Appendix I., p. 15.

TABLE SHOWING THE AREAS OF OBJECT-GLASSES
 AND MIRRORS OF DIFFERENT SIZES.

Diameter. inch.	Area. sq. in.	Diameter. inch.	Area. sq. in.
1	0.78	6½	33.1
2	3.1	6¾	35.7
2¼	3.9	7	37.9
2½	4.8	8	50.2
2¾	5.9	9	63.6
3	7	10	78
3¼	8.2	11	95
3½	9.6	12	113
3¾	11	13	132.7
4	12.5	14	153.9
4¼	14.1	15	176.7
4½	15.9	16	201
4¾	17.7	17	226.9
5	19.6	18	254.4
5¼	21.5	21	336.3
5½	23.6	24	452.3
5¾	25.9	30	706.8
6	28.2	36	1108.6
6¼	30.6	48	1809.6

On the question (often much discussed) as to the relative importance of aperture as regards the effective scrutiny of objects, the following remarks by J. E. Keeler^d are interesting:—

“The instrumental means at command on Mount Hamilton have given me an excellent opportunity for testing the comparative efficiency of large and small telescopes under identical circumstances. The observatory possesses three equatorials, with object-glasses of 6½, 12 and 36 inches clear aperture, all of Alvan Clark and Sons’ best make. Objections have justly been made to the use of different apertures on the same telescope, and to comparisons of different telescopes when not made by the same person. My own eyesight is far from being acute, and I would not compare my observations with those of another person using even a much smaller instrument, but conclusions drawn from experiments made by the same observer, under the same circumstances, with instruments of the highest degree of excellence differing only in size, are certainly valid. According to my experience, there is a direct gain in power with increase of aperture. The 12-inch equatorial brings to view objects entirely beyond the reach of the 6½-inch telescope, and details almost beyond perception with the 12-inch are visible at a glance with the 36-inch equatorial. The satellite of Neptune is to me always a difficult object with the 12-inch telescope, but it was very conspicuous with the great equatorial on the night of January 9th [1888], and if there had been another satellite of only one fourth or one-fifth the brightness of the one already known, it could not have escaped

^d *Sid. Mess.*, vol. vii. p. 82. Feb. 1888.

detection. The great telescope is equal in defining power to the smaller ones, and has in addition the immense advantage of greater light-gathering power, due to its superior aperture.

“Of course great size carries with it certain disadvantages. The telescope cannot be turned rapidly from one part of the sky to another, and observing is necessarily slow work, even with the most perfect mechanical appliances. It can however be employed on the work for which it is best suited, work entirely beyond the power of small instruments, while for these will remain fields of labour in which they will never be superseded by large ones.”

The intending observer would do well to allot a portion of his funds to the purchase of an equatorial stand (coupled with clock-work to drive the telescope with, if the aperture of his glass exceeds 4ⁱⁿ), in preference to concentrating his means on a larger glass imperfectly mounted; for without these 2 aids his work will be very tedious, particularly if he proposes to study faint objects of any kind.

The parallel-wire micrometer is of course the “arm of precision,” but for most amateurs a reticulated micrometer will suffice: it should be applied to an eye-piece of rather low power, say, intermediate between the 1st and 2nd of the “battery,” as it can there be made to do double duty to some extent. The 1st ordinary power should have as large a field as possible, that it may be used for sweeping for comets.

As regards cleaning lenses of all kinds, the first and most important rule is, never to meddle with them except in cases of the most pressing and obvious necessity. Optical glass requires careful and delicate treatment, and a few specks of dust are of much less moment than ugly scratches, never afterwards to be removed. A soft camel's-hair brush will be found of much use for removing coarse particles of dust from lenses; then the application of the brush may be followed by the cautious use of a piece of very fine and clean chamois leather, or of a soft silk handkerchief: better, however, than either of these is an old but fine cambric handkerchief. Everything used for wiping or rubbing lenses should be kept wrapped up in paper or in a little box when not in use, and the wiping or rubbing should be performed very gently. A drop or two of spirits of wine on chemically clean cotton wool will be found very useful for

removing refractory stains, but the careful observer will never allow any refractory stains to get on his glasses. Small lenses deeply set in high-power eye-pieces may be cleaned with freshly cut elder-pith.

The brass-work of a telescope should be dusted from time to time: if it gets a little dull or dirty, no better application can be found than a piece of chamois leather, moderately moistened with sweet oil.

When out of use for more than 2 or 3 days, it will be found advantageous to keep the entire instrument, stand included, covered with an old sheet or table-cloth, *except in damp weather*.

Something should be said on the management of Reflectors, and on preserving the silvered surfaces of the mirrors thereof^e.

Several methods, depending on the employment of deliquescent chemical substances, have been proposed for preventing silvered surfaces from becoming tarnished. All are troublesome, and sometimes they do more harm than good. Practically, it is quite sufficient that the mirror, when not in use, should be protected by a tightly-fitting cover^f.

It is a good plan to envelope the telescope, when not in use, in a wrapper made of American leather cloth. Should the mirror be left in its place, such a covering shelters the mirror, and under any circumstances, it will keep dust out of the instrument. If, in spite of precautions, a deposit of moisture should have taken place on the mirror, or rain have fallen on it, the mirror should be gently warmed in front of a fire, and kept there until the moisture has evaporated and the surface become dry. If stains should be left, they may be removed by polishing in small circular strokes with a rouged leather pad, first letting the mirror cool. The pad should be warmed to dry it, but allowed to get cool before being used.

However much the surface of the mirror may seem to have

^e These remarks have been inspired by Mr. Browning, who is a practised observer as well as a good optician.

^f The larger sizes of reflectors are often

made with a door in the lower part of the tube, for the purpose of covering and uncovering the mirror without removing it from the tube.

got out of condition, if these instructions be followed its original state of polish may be restored to it, but *if the moistened surface be rubbed before it has become perfectly dry, the silvering will be damaged.*

As a general rule the best thing to be done, is to *let the silver coating alone as much as possible.* There is no necessity to envelope the whole telescope tightly, merely because it is left in the open air; indeed, it is better not to do so. The laws of radiation are such that more likely than not the instrument will be injured by too much cossetting. A loose-fitting wrapper (water-proof of course), which protects it well from the direct impact of rain, is all that is required.

It is necessary also to have and to use a small brass cover, which can be slipped over the diagonal mirror without removing it, or altering its adjustments.

Silvered surfaces should not be subjected to any rubbing oftener than once in 6 months at the utmost, and if handled with reasonable care, should last without renewal for 3 or 4 years.

A mirror should not be taken from the cold air into a warm room; or, when this cannot be avoided, the cover should be placed on the mirror while it is in the open air, or in a cold place, and the mirror and cell should be put in a box with a well-fitting lid, before it is removed to the warm apartment. This will prevent a deposition of moisture.

Lassell pointed out that specula require a few minutes to settle into definition after having been shifted through any considerable distance.

ON THE CHOICE OF STANDS, ETC.

This is little else than a financial matter, but it is a very important one. Beyond doubt more may be got out of a small instrument on a good stand than out of a large instrument on a bad one. A good stand means not simply a steady but a manageable one, and a manageable stand means an equatorial one. Every telescope of and beyond 3ⁱⁿ aperture ought to be

equatorially mounted; and, after all, the measure of the usefulness of a telescope is the work that can be done with it much more than the inches of its aperture. Objects invisible to the naked eye—*i.e.* the majority of the objects in the starry heavens—can, as a rule, only be found after much labour and loss of time by an observer who is unprovided with an equatorial mounting: the waste of energy thus engendered trenches materially on his available opportunities and sense of pleasure. Where the site can be had, an iron pillar out of doors is the best substitute, and the metal-work forming the equatorial, which need not be very fine or elaborate, can readily be protected from the weather, the telescope itself being kept in the house and carried out when wanted. In other cases a wooden tripod may be used; these may now be had solid enough to be steady without being too heavy to be portable. The circles attached to the hour and declination axes need not be too finely graduated, if, as is commonly the case, they are merely intended to be used for finding objects, and the coarser the graduation the less expensive they are.

If you are so circumstanced as to be able to have your stand a fixture, it is here proposed to recommend that it be covered over by an observatory. The name is formidable, but a carpenter's shop and 20*l.* or so will provide you with one for a small equatorial^s; and the comfort and protection afforded to yourself and your instrument will in a very few weeks be demonstrated. Finally, with an equatorial mounting, and an observatory to cover it, you should have clockwork to drive it. It must candidly be confessed that this is an article of luxury, but still for high powers it is very desirable, and for micro-metrical measurements and pencil-and-paper delineations it is virtually indispensable.

Clockwork specially contrived to drive an equatorial of the size likely to be employed by ordinary amateurs is a matter of from 15*l.* to 20*l.*, but an observer who is of a mechanical turn

* See Chap. VII., *ante*.

of mind will be able to provide himself with something fairly efficient at a far less outlay. Admiral Smyth, when needing the assistance of clockwork for his telescope, was advised by Babbage to fit up a kitchen-jack for the purpose, and was preparing to do so, when Sheepshanks made him a present of the driving apparatus exhibited in Fig. 51 (*ante*), of which an enlarged

Fig. 133.

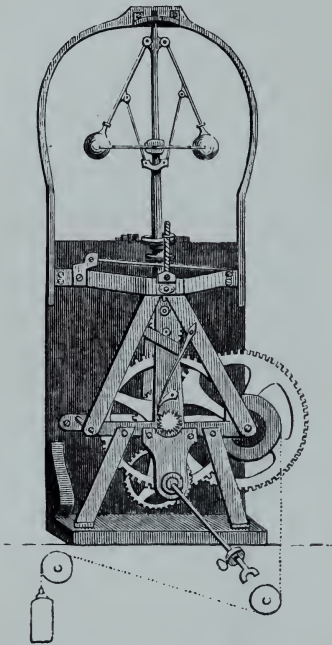

SIMPLE FORM OF DRIVING CLOCK.

representation is annexed. A train of wheels is made to carry a governor similar to that of a steam engine, and its axis; which revolving swiftly causes the regulating balls to separate, and with the aid of an absorbing wheel, gives a smooth action to the hour-circle; yet under such control as to be readily adjustable to sidereal, solar, or even lunar motion. As the balls of the governor separate by centrifugal force they elevate a collar which is attached to the middle of a lever reaching entirely across the clock. This lever communicates with a shorter one below it, in immediate connexion with the train of wheels, and thus the elevation of the balls governs

the whole. The rate being regulated by the rod connecting the 2 levers, it then only remains to transfer the motion to the tangent screw of the equatorial hour-circle by a rod with a Hooke's joint. The foregoing is Smyth's own description of the apparatus the performance of which he described as "simple and effective^h."

Under the name of the "Parallactic Ladder" Admiral Smyth

^h *Cycle of Celestial Objects*, vol. i. p. 341. For more on the subject of Driving Clocks, see Lockyer's *Stargazing*, p. 318.

described a contrivance which was constructed and presented to him by Dollond the optician. It was a modification of a mounting which he saw in Dr. Pearson's garden at South Kilworth in 1827, and which was sufficiently large and strong to bear the Doctor's 12^{ft} telescope of 6·8ⁱⁿ aperture—then the

Fig. 134.

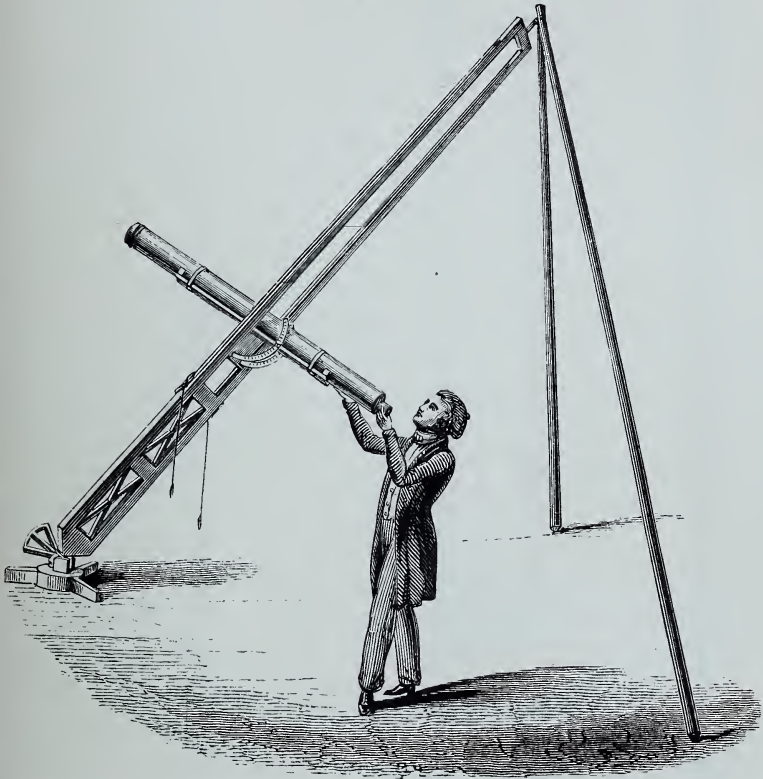

THE PARALLACTIC LADDER. GENERAL VIEW.

most powerful refractor in England. Smyth speaks of this ladder as at once cheap and efficient, and capable of being made by any common workman. In his opinion it combines economy and convenience; is easily put up in any open place, and if a little care is taken to place it as near as may be in the meridian and pointing to the Pole it will be found a steady and useful

equatorial stand for any sized telescope the tube of which is of such diameter that it can be attached to and repose on the

Fig. 135.



A strut or shear.

Fig. 136.



Front of the frame.

Fig. 137.

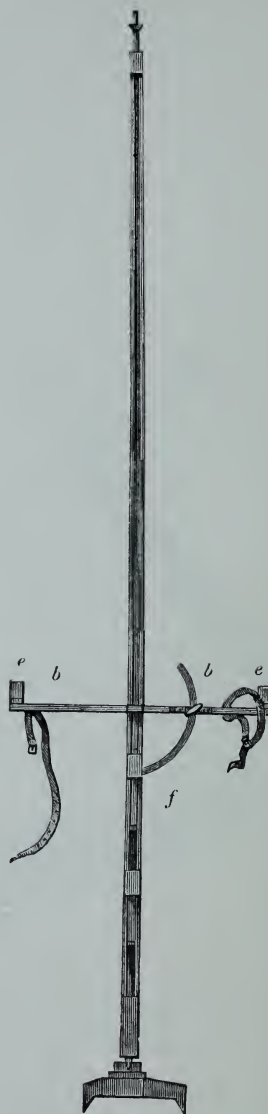

Section of the frame.

THE PARALLACTIC LADDER. DETAILS OF THE FRAME ¹.

¹ The scale is $\frac{3}{8}$ in to 1 ft.

cradle *bb*. This cradle, moving on hinges, is attached to cords which pass over the pulleys *cc*, and are made fast by passing them round the cleats *dd*, when the cradle is triced up along grooves in the sides of the frame *aa* to the height which will be the most proper for the Declination of the star, and the convenience of the observer, whether standing or sitting. The telescope is laid into the cradle ends *ee*, which form the Y's, and there made fast by the straps nailed on to the lower part of the cradle, as represented; it is then secured at a proper Declination by a nut-screw, on the iron arch *f*, of which there is one on each side; and if well made, they materially steady the whole. It will now be readily seen, that if the frame be placed with its lower or S. pivot in the iron triangular-piece *g* (which must be previously placed upon the S. end of a meridian line) and the upper or N. end united to the two struts, sheers, or supports (the shape and dimensions of which are seen in the engraving, Fig. 136), and spread out until the frame is placed at the polar elevation, it will thus have three very steady supports, and become in every respect a polar axis, having its two pivots *h* and *h'* in the position parallel to the poles of the earth. The drawings show so clearly the size of every part, that they will enable any carpenter to frame such a stand to any dimensions; with the trifling assistance of a smith to make the iron triangle or southern support, with the bolt and connecting pieces for the northern support. As these are the principal matters of detail—both ends being pivots of rotation—they are here represented in Fig. 139 on a larger scale. The utility of the parallactic ladder is increased by the addition of a circular arc to the pivot-socket, roughly marked with lines, showing three hours on each side of the meridian; which are pointed to by a pin at the lower end of the ladder-frame. This, with some equally primitive notches for degrees of Declination in the arc *f*, renders it more useful as a finder. A figure of the triangle with the hour-arc may be acceptable to the workman. With a stand of this description, the observer, after a little practice, will be able to follow any celestial object with one motion, which in the present con-

struction must be given by the hand. But if desired, some method of obtaining a slow motion may be adopted; so that an object may seem to remain stationary in the middle of the field of view. However, even without any such adjunct the ladder is at once useful and pleasant for observing the more ordinary phenomena of the heavens, such as the spots on the Sun, the phases of Venus, the gibbosity of Mars, the flattened poles, belts,

Fig. 138.

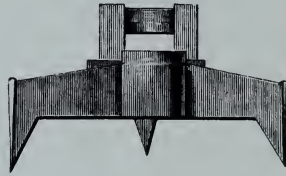

Fig. 139.

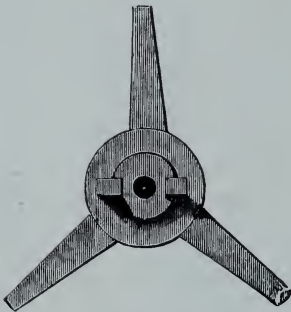
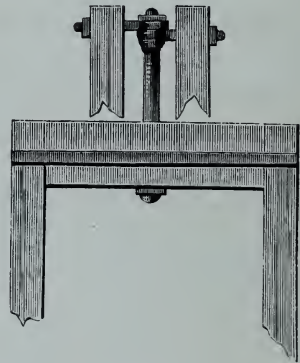

Fig. 140.



THE PARALLACTIC LADDER. DETAILS OF THE PIVOTS.

and moons of Jupiter, the rings and details of Saturn, the selenography of our satellite, the aspect of comets, eclipses, occultations of stars or planets, and the immersions and emersions of Jupiter's satellites. With a ladder of this description standing at or near his domicile an amateur will be ready for any phenomenon; for the carrying out and mounting of the telescope is but an affair of two or three minutes.

Reflectors being more susceptible to the influence of changes of temperature than refractors should be used as much exposed

to the air as possible. If kept under cover they should be uncovered as long and as completely as possible before observations are commenced. Many observers who possess large reflectors keep them altogether out of doors. In such cases they themselves should be under shelter, and for this purpose a sliding "observing box" devised by Browning will be found useful.^j The construction of this contrivance will be understood from an inspection of Figs. 142-3. In the latter it will be noticed that

Fig. 141.

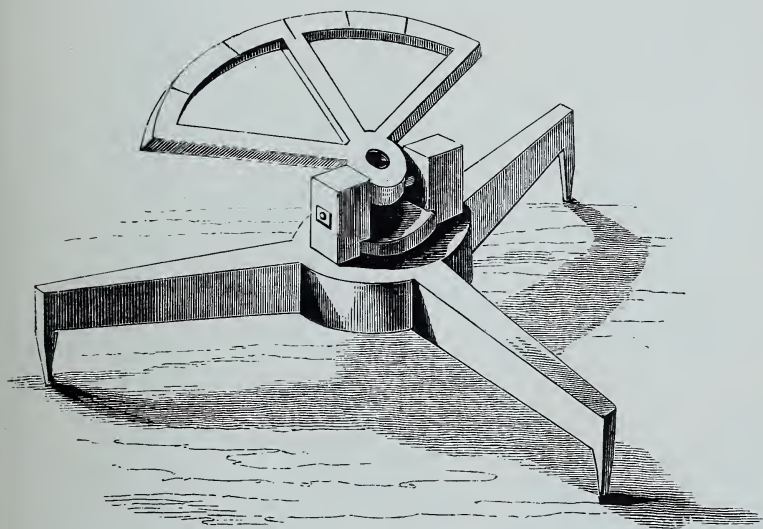

THE PARALLACTIC LADDER. DETAILS OF THE S. FOOT.

at each corner of the structure there is a hollow triangular pillar. These pillars are attached to two strong triangles framed of suitable timber. The observing box, which is also triangular in plan, fits loosely between the 3 upright pillars and runs in grooves, placed on the sides which face inwards. The weight of the box is borne by ropes which run over pulleys and down the inside of the hollow pillars. At the end of each rope is a counterpoise, and the three counterpoises must be collectively

^j *Month. Not.*, vol. xxxi. p. 172. March 1871.

slightly heavier than the box and the observer therein. A door on one side of the box gives access to it. On the lower edge of the openings in this door and at a convenient height there should be a shelf or desk-slope which may be made a fixture or moveable

Fig. 142.

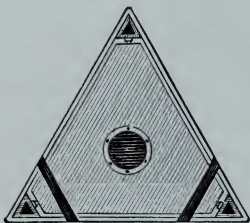
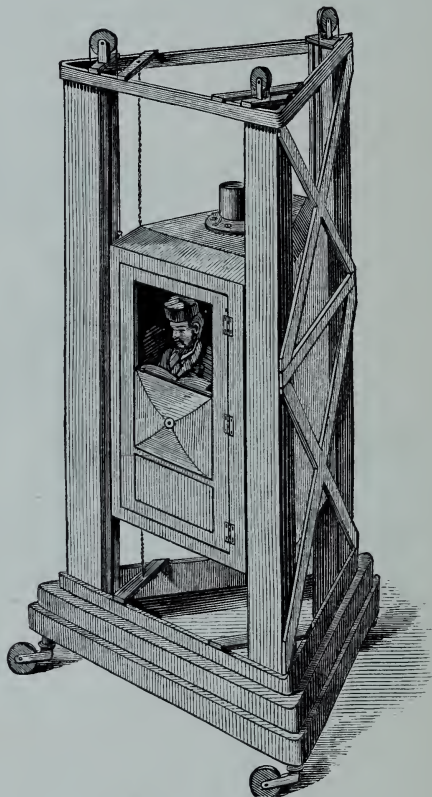

Fig. 143.



BROWNING'S OBSERVING BOX.

as may be deemed preferable. The observer sits in an ordinary chair, a chair having been found in practice more comfortable and convenient than any seat fixed to the box. Two strong cords attached to bars running across the front corners of the frame are carried through small circular holes in the top and bottom of the box one on each side of the observer. In order to

shift his position the observer has only to take hold of these cords, and if the weight of the box with him in it is counter-balanced with fair accuracy, a very slight amount of muscular force will enable him to move up and down in the frame. A few loose weights should be at hand to vary the adjustment should persons of different weights from the person for whom the box was constructed require to use it. In the roof of the box some provision should be made for ventilation.

In addition to all the above paraphernalia a chronometer, or well-made clock, set to sidereal time is needed. It is by no means necessary in a general way that this should be an expensive or highly-exact instrument; an ordinary good parlour time-piece, costing from 6*l.* to 10*l.*, will meet all the requirements of the amateur. In the absence of a Transit Instrument specially intended for the determination of the time, the equatorial (presuming it to be in proper adjustment) set in the meridian—that is to say, with its declination axis horizontal—will give the time with a fair approximation to the truth.

Steinheil of Munich makes a little miniature transit instrument which is not unworthy of the notice of amateurs. It consists essentially of a prism so mounted that the frame which carries it can be screwed into a window-frame or other similar support in such a way that its outer face shall coincide with the meridian and be directed to the East. When this has been done approximately by hand, precise accuracy can be obtained by means of slow motion screws for altitude and azimuth which are provided for the purpose in connection with the main shaft of the instrument. On the end of this shaft, away from the wall attachment, *i.e.* at what is the East end when the instrument is in position, there moves

Fig. 144.

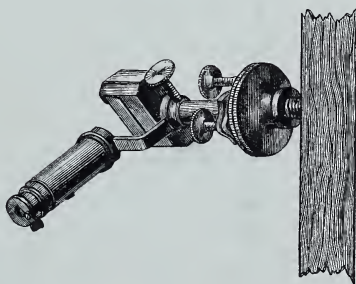

STEINHEIL'S TRANSIT PRISM.

freely a ring from which projects a bent arm, into a ring on the farther end of which a small telescope screws, so arranged that the edge of the prism bisects the object-glass of the telescope. This arm will move freely in altitude, and in doing so will carry the prism along with it. By a clamping screw the instrument may be fixed at any desired altitude. On looking through the telescope at any object approaching the meridian 2 images of it are seen. These gradually approach each other, and the moment of actual coincidence marks the meridian passage of the object, presuming of course that the instrument is itself accurately adjusted to the meridian. A coloured glass is attached to be used when it is desired to observe the sun.

This instrument packs into a box about 5ⁱⁿ long, 3ⁱⁿ wide, and 2ⁱⁿ deep; and is said to be capable of giving the time either by the Sun or by a star to within one second. An observer who has worked with it says that as a Transit Instrument for amateurs who have neither the means to obtain nor the time to use elaborate and expensive instruments nothing more simple or accurate could be desired^k.

Failing a sidereal clock or some other ready means of obtaining sidereal time, a rude dial constructed as follows will be useful. Carefully cut 3 discs of card-board, respectively 12, 10 and 8 inches in diameter, and fasten them together concentrically in regular order, the smallest uppermost. Graduate the inner edge of the annulus made by the middle-sized disc on the largest into 60 equal parts to represent minutes of time, marking off every 5th minute with Arabic figures on the outer edge. Graduate the outer edge of the middle disc likewise into 60 equal parts. Immediately within this graduated annulus graduate another annulus into 12 hours with Roman numerals. Graduate a 3rd annulus at the inner edge of the self-same disc into 24 hours, reckoned by twelves and indicated by Roman numerals corre-

^k This instrument is sold in London by Horne and Thornthwaite. Its principle was expounded by Steinheil in the *Kunst und Gewerbeblatt für Bayern*, Munich, 1845, p. 4; *Ast. Nach.*, vol. xxiv. no.

569. July 30, 1846. See also a paper by the Rev. W. Hodgson in the *Edinburgh New Philosophical Journal*, vol. xlviii. p. 269, 1850; vol. lii. p. 137, 1852.

sponding one XII to the XII of the first set of Roman numerals and the other XII to the VI of the first set. Opposite the former XII write the word noon; opposite the latter XII, the word midnight; opposite the VI on the right-hand side, the letters P.M.; opposite

Fig. 145.

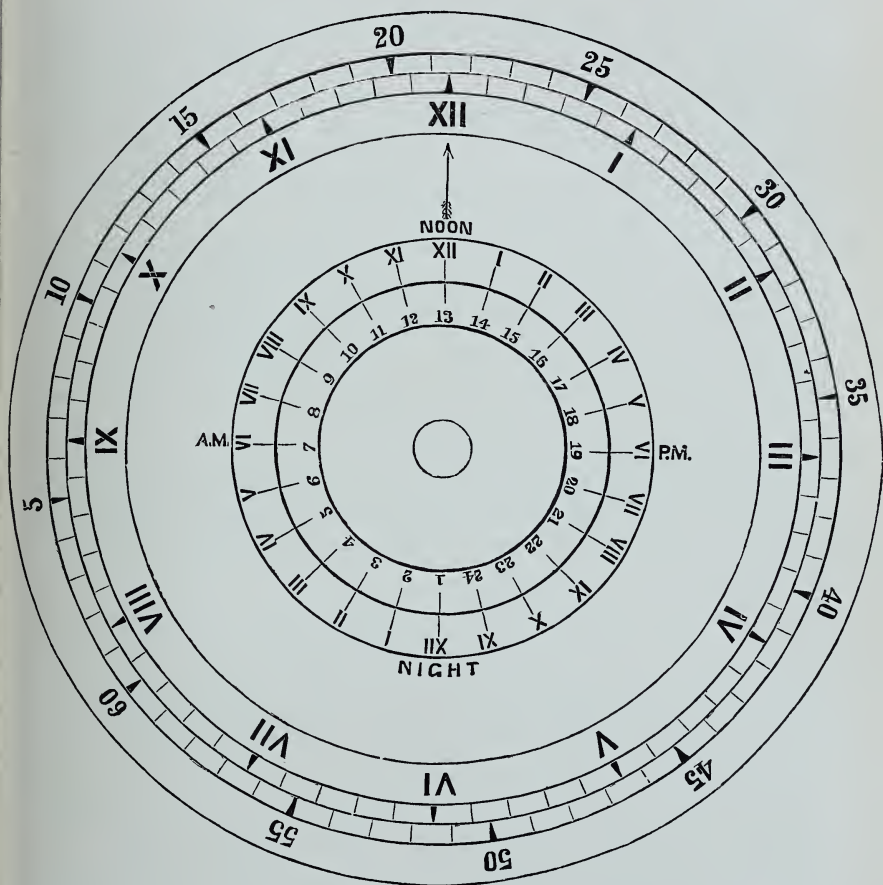

SIDEREAL TIME INDICATOR.

the VI on the left hand, the letters A.M. Graduate the outer edge of the smallest disc into 24 equal parts marked by Arabic figures (which will stand for sidereal hours).

This contrivance should be mounted on a board and hung up

so that the noon xii of the middle or mean time disc should always be at the top: it will then be looked at as one looks at a common clock.

To use the indicator nothing more is required than a copy of the *Nautical Almanac* and a respectable watch indicating Greenwich mean time.

To set the dial for any place under the meridian of Greenwich look in the *Nautical Almanac* for the sidereal time at mean noon on the day of the dial being wanted: turn the innermost disc so that the sidereal *hour* given shall be opposite the noon line; then turn the outermost disc so that the sidereal minute or fraction thereof shall also be opposite the noon line.

For places which are East or West of Greenwich the sidereal indicator must be set to a point so many minutes and seconds to the left or right of the noon line as correspond with the longitude (in time) of the place. This adjustment once ascertained, should be preserved by a suitable mark on the mean time minute-circle (on the middle disc). For every 6 hours of mean time that have elapsed since noon, the sidereal minute-circle must (after the time has in the first instance been found) be pushed backwards one division (or minute), or $\frac{1}{6}$ minute for every hour.

Note that when the number 60 of the outermost or sidereal minute-disc intervenes between the noon line and the given mean time minute on the middle disc, as one reads the clock, the reading of the sidereal hour obtained from the innermost disc must be increased by 1^h.

By means of a dial of this sort tolerably well graduated, sidereal time may be ascertained within a few seconds. To facilitate the readings one or several of (or better still, all) the divisions on the mean time minute-circle (on the middle disc) might be divided into 6 equal parts each of which would represent 10 seconds¹.

¹ The foregoing description has been re-arranged and re-written from a paper in the *Engl. Mech.*, vol. xvi. p. 116. Oct.

18, 1872. The accompanying woodcut I owe to the kindness of the Editor of that paper.

If your stand is a portable one, and your observations are carried on whenever and wherever may be convenient, there are some little precautions to be attended to which may here be dealt with. Avoid a window if possible, especially in winter. The inequality between the temperatures of the external and internal air (which can at best only be reduced to a not very low minimum) will be found productive of currents and disturbances in the air seriously detrimental to satisfactory observation. If you cannot help observing from a window, open it a considerable time before you intend to commence operations. This will tend to mitigate the evil. When your proceedings are terminated, cover up the glass-work, especially the object-glass, before bringing it into a warmer atmosphere; otherwise, in consequence of its being in a chilled state, its transfer into warm air will probably lead to its becoming bedewed, and this can do it no good, and may cause much trouble.

BOOKS, ETC.

These will be ranged in 2 classes: "essential" and "very desirable." Under the former head I include:—

1. An Ephemeris.
2. A Manual of Celestial Objects.
3. A set of Maps.
4. A Manuscript Note-book.

1. Each nation of importance has its own Ephemeris: each says its own is the best. Four may be said to occupy the front rank: the English *Nautical Almanac*, the French *Connaissances des Temps*, the German *Berliner Astronomisches Jahrbuch*, and the American *Nautical Almanac*. The amateur will find much useful information in Whitaker's *Almanac*, in the *Observatory*, and in the *Sidereal Messenger*^m, the two latter being periodicals which every English-speaking astronomer ought to take in. Flammarion's *L'Astronomie* published at Paris is also a cheap and very useful

^m Published at Carlton College Observatory, Northfield, Minnesota, U. S. Price 2 dollars a year.

Monthly Magazine of Astronomy, whilst the Germans have their *Sirius*, an old-established Magazine published at Cologne.

2. As a Manual pointing out objects worth looking at, Admiral W. H. Smyth's *Bedford Catalogue* (2nd ed., 1881) is unrivalled, and the lists in vol. iii. of the present work will also be found useful. Webb's *Celestial Objects* is a well-known work.

3. The Maps of the [London] S. D. U. K. are clear and complete, but of awkward size and distorted at the edges. More popular and for amateurs more handy is Argelander's *Uranometria Nova*. Heis's *Neuer Himmels Atlas* is also a useful work. For general use I have found no maps so handy and at the same time so good as Hind's, published in Keith Johnson's *Atlas of Astronomy*. The stars are white on a blue ground, and this makes them very legible at night. Schurig's *Himmels Atlas* is very good and very cheap (3s. 6d.): stars black on white ground, all lettered or numbered; and clusters and nebulae to boot. The newest popular atlas is Klein's, translated and adapted for English readers by the Rev. E. McClure (S. P. C. K.). This is a cheap and useful work—atlas and catalogue of objects in one. For the Southern hemisphere exclusively, Behrmann's *Atlas des südlichen gestirnten Himmels* is the only existing work.

The 4th book I very strongly recommend. Captain Cuttle's principle of "When found, make a note of it," is pre-eminently sound from an astronomical point of view. Every little circumstance seeming to be out of the common should be placed on record; no harm can be done; the task, if such it be, will not cost much time or trouble, and great results may at some time or other accrue. Many important discoveries have been brought about by observers careful, and habituated, to take note of trivial matters—as witness the discoveries of Uranus and Neptune. Above all things write down your impressions at the moment; otherwise, come the next morning, and their value will be lessened; or it may even happen, and that not seldom, that they will be so confused and muddled as to be of absolutely no value at all. Especially does this apply to drawings. If making notes and taking sketches has no other use, it serves to

train the mind to habits of attention and thought, and that is a thing not to be lightly esteemed. An American writer has thus expressed himself:—"Very much can be done in the way of self-instruction if the common observer will give attention to what he sees, and form the habit of writing down the substance of what has been seen. It is quite useless to try to remember almost anything that one wishes to reproduce accurately. Definite notes must be taken at the time and while the object is before the eye, if a person wishes to be sure of what he has seen, or to have any real value attach to his ideas in the future."

Amongst very desirable books I include—

1. A book of Logarithms.
2. A standard Star Catalogue.
3. One or more General Treatises on the science.
4. A Manual of Practical Astronomy.

1. Of Logarithms, one of the best books is Vega's by Bremiker, of which an English edition is published by Williams and Norgate. Bruhns's *Logarithms*, published with an English Preface by Tauchnitz of Leipzig, 1870, is also a first-class work. Less pretentious is De Morgan's, published by the S. D. U. K., and the Book of Mathematical Tables published in the "Edinburgh Course" of W. & R. Chambers.

2. The most useful Star Catalogue is that published in 1845 by the British Association, now unfortunately very much out of date: less comprehensive (being mainly a circumpolar catalogue) is the Radcliffe. There are many others which may serve one's purpose. For stars of magnitudes 1 to 6 Pickering's Photometric Catalogue in vol. xiv. of the *Annals of Harvard College* is a work of extreme value. A popular abridgement of it will be found in vol. iii. of this work.

3. Herschel's *Outlines*, Arago's *Popular Astronomy*, Lardner's *Handbook*, Lord Grimthorpe's *Astronomy without Mathematics*, Young's *General Astronomy*, and many others, might be suggested under this head. Those who can read German will find several good treatises in that language, *e.g.* Klein's. Many treatises in French have been published of late years, but some are too

wordy for "Britishers." The best is Delaunay's *Cours élémentaire d'Astronomie*. Some American writers, *e.g.* Newcomb and Holden and Young, have produced some extremely serviceable books.

4. As a Manual of Practical Astronomy none surpasses Loomis's. It is at once good, concise, and complete. More elaborate is Chauvenet's masterly work, but most amateurs will find it too advanced.

Having said thus much on the preparations to be made in starting an astronomical campaign, I will conclude with a few hints on the observation of the several classes of celestial objects.

THE SUN.

The intense heat and light of the Sun necessitate under ordinary circumstances the defence of the eye by some special expedients. These are very various, but the interposition of coloured glass between the eye-piece and the eye is the most usual device. The only occasions when nothing is needed is when the Sun is very close to the horizon, or when it is viewed through a thick [*e.g.* London] fog. It is worthy of note that a fog-dimmed Sun is often an extremely well-defined one, the peculiar features of the solar surface being brought out with unusual clearness.

As regards coloured glasses some remarks may be made. The warm colours—red, orange, &c.—must be avoided, though some persons recommend them; and on the whole it may be said that the choice is between neutral tint and green; the latter is most frequently met with, but the former is regarded with most favour by experienced observers. Various astronomers have advocated "dodges," in the shape of chemical solutions and other liquids; some pour their solutions into the eye-piece itself; others arrange them on the outside in glass vessels, with parallel sides: it may, however, well be doubted whether these and such-like expedients are worth a tithe of the trouble and

mess to which they give rise. The claims of the wedge of dark glass are of a higher order, and the facility with which it can be slid backwards and forwards as the intensity of the solar light varies, constitutes a strong recommendation. Smoked glass and combinations of coloured glasses—red and green, green and cobalt-blue—have also their partisans^m. It is necessary to caution the observer that with any telescope in which the Sun is to be viewed without the “Diagonal” eye-piece mentioned in the next paragraph, the aperture must be contracted to $2\frac{3}{4}$ in or so, or the dark glasses will quickly be cracked.

The observer whose operations are not hampered by pecuniary considerations, and whose telescope exceeds 3 in in aperture, will, however, avail himself of more elaborate appliances, such as the “Diagonal” or the “Dawes” solar eye-pieceⁿ.

Dawes’s contrivance (it is hardly an “eye-piece”) is very useful for general celestial purposes—such as the examination of a faint sidereal object without the presence of a more luminous neighbour.

Concerning another very serviceable method of examining the Sun, I cannot do better than quote the following remarks from the pen of the Rev. T. W. Webb. “There is, however, a totally different mode of observation, which, if less striking, and less adapted for minute details than direct vision, is far more easy and convenient—that of projection: in which the image is transmitted through an ordinary eye-piece, adjusted, by trial till perfect distinctness is obtained, to a large opaque screen at a suitable distance behind it. If this screen is white, smooth, and carefully arranged at right angles to the axis of the telescope, the correct focus being also carefully determined by repeated trial, this method will give a very fair representation of the principal solar phenomena. Mr. Howlett, indeed, who makes great and successful use of it, tells us that he even gets

^m Foucault is said to have once constructed what he found to be a very convenient *helioscope*, by covering the outside face of an ordinary telescope with a thin film of silver or gold. Burnished, the

metallic surface reflected most of the incident rays, yet transmitted sufficient for forming an image distinct and available for ordinary purposes.

ⁿ See p. 26, *ante*.

a more perfect view in this way than by direct vision. At the same time it has the great merit of supplying us with an accurate and inexpensive micrometer, the image of the Sun being made by proper adjustment to coincide with a circle graduated by lines into suitable divisions; and thus the position of the spots may be measured, and their progress made evident from day to day. Carrington, one of our best solar observers, employed this mode, projecting the image on plate-glass coated with 'distemper' of a pale straw colour. A large piece of card-board, with a hole in the middle to slip over the object-end of the telescope in the place of the brass cap, must be provided to throw a shade upon the screen; and the latter, if measurement is the object, must be attached to a bar made fast to the telescope, and partaking of its motion.

"Hornstein and Howlett, by inserting in the focus of the eye-piece (which for this purpose should be of the 'positive,' or Ramsden construction) a slip of glass micrometrically divided, projects its image, together with that of the Sun, as a scale upon the screen. The latter gives the following dimensions, which may be useful as a guide:—Telescope $3\frac{3}{4}$ inches aperture; in a darkened room; power 80; card-board screen on easel, 4 feet 2 inches from eye-piece; glass micrometer in focus divided to 200^{ths} of an inch, each division giving about $\frac{1}{2}$ inch on screen, where a corresponding scale is drawn with ink, every 16th of an inch representing about 4". With other powers other distances would be required for the screen. With a good telescope, magnifying may of course be pushed much further; but beyond 80, or at the most 90, the field would probably fail to admit the whole disc of the Sun°. Captain Noble states that he obtains extremely beautiful views of the solar phenomena by fitting on to the eye-piece the small end of a card-board cone, 1 foot long and 6 inches across the larger end, which is filled by a disc of plaster of Paris, carefully smoothed while wet on a sheet of

° Observers desirous of information respecting Howlett's arrangements for viewing and measuring spots on the Sun,

must consult his paper on "Sun Viewing and Drawing" in the *Intellectual Observer*, vol. xi. p. 429. July 1867.

plate-glass; on this the image is projected, the interior of the cone being blackened, and an opening made in its side to view the face of the plaster screen."

The most convenient time of the day for systematic observations of the Sun for the purpose of delineating its disc by means of the method of projection is the hour of noon, because the correct orientation of the solar disc can then be ensured. The E. will be to the left; the W. to the right; the N. above; and the S. below; for it must be borne in mind that the telescope reverses the image twice; first at its exit from the object-glass, and again at its exit from the eye-piece; so that the final image is not reversed at all, as looked at on the screen from the upper side thereof. In the morning and the evening, on the other hand, the orientation may be said to be all nowhere, so to speak; the Sun's polar diameter is not vertical and its equatorial diameter is not horizontal, and drawings made under these circumstances will be apt to mislead the observer.

In hot weather, whatever be the size of the telescope employed, it is a great advantage to have the opening in the observatory roof covered over with a thick and dark curtain having a round hole in it for the telescope tube to pass through: such a curtain protects both the observer and the metal-work of the instrument, and the advantage of such protection will soon be comprehended after a trial of it.

THE MOON.

Concerning the Moon I merely pause to remark that a neutral-tint glass of feeble intensity will be found a very useful adjunct for the scrutiny of the lunar surface, especially when a telescope of considerable size is employed^p.

^p The volumes of the *Ast. Reg.* for 1880 and 1881 contain a series of articles by the Rev. W. J. B. Richards and Mr. W. R. Birt entitled "Lessons in Selenography," which well deserve the attention of those

who desire to become proficient in Lunar observations. The article which deals especially with instrumental appliances will be found in vol. xix. p. 146. June 1881.

PLANETS.

For the purposes of amateurs possessed of ordinary telescopes, the planets may be ranged under 2 very distinctly-defined classes, the *interesting* and the *uninteresting*: under the former head I include Venus, Mars, Jupiter, and Saturn; under the latter, Mercury, the Minor Planets, Uranus, and Neptune, all of which are practically inaccessible to the telescopes which are usually in the hands of those to whom these pages are primarily addressed.

For viewing the first group of planets no very precise instructions are necessary. Provided that the air is sufficiently favourable for obtaining good definition, almost any power may be used; the higher the better; bearing in mind the fact that the excessive brilliancy of *Venus* makes the best time for observing it to be during daylight. When close to its inferior conjunction, either before or after, with the illuminated portion of its disc reduced to the thinnest conceivable crescent, hardly distinguishable from a mere curved line, Venus is an object of peculiar elegance. There appear to be grounds for the opinion that Venus is, on the whole, to be seen more satisfactorily with Reflecting than with Refracting Telescopes^a.

The following Instructions to Observers of Venus are based on a circular drawn up in 1871 by Denning for the use of the "Observing Astronomical Society:"—

Every fine day should be turned to account, and, when any markings or special features are visible, watch them as long as possible and note any changes either of shape or position. Observers usually examine this planet for detecting surface markings, and for noting irregularities in the terminator or differences in the relative sharpness of the cusps. The following directions may be useful in recording these peculiarities and making sketches of the same:—

I. *Position.* In delineating the visible markings observers should employ a circle divided into 4 quadrants by 2 cross-lines at right angles to each other. The outlines of the telescopic image should be filled in so that the horns are equidistant from the

^a This idea is expanded by Lassell. He writes:—"It is one of the advantages of a Newtonian reflector, when the alloy of the speculum is well compounded, that colours of planets are more faithfully

represented than they can be by refracting telescopes, the want of perfect achromatism in the latter generally introducing some modifying tinge." (*Month. Not.*, vol. xxxii. p. 83. Jan. 1872.)

vertical line. Then the configuration of the crescent, as observed in detail, should be portrayed as faithfully as possible.

II. *Time.* The day and hour must be affixed to each sketch. Remarks may be appended as to whether any of the features have been observed before, with the dates, and also whether any variations have occurred.

III. *Appearance.* The degree of visibility, the colour and the apparent forms of the markings should be carefully estimated.

IV. *Variations.* Changes in the shape or places of any spots must be recorded with the utmost accuracy and fulness.

V. *Instrument.* If the observations are intended for publication anywhere, the character of the telescope employed should be stated; and also its aperture and magnifying power.

Note. In drawing the aspect of the planet all endeavours at *artistic effect* should be made to give place to simple *fidelity of representation*. The observer should depict the appearances seen just as they impress his eye; and should give them their due proportions, outlines and tones. To be really valuable, drawings must be true.

Daylight is the best time in which to observe Venus. At night the planet's excessive lustre occasions glare, and the definition is seldom good even in the best telescopes. Moreover, in the daytime the altitude of the planet is usually greater, and consequently the view is not so much liable to the distortions induced by the vapours near the horizon. At about the time of sunrise or sunset the details of planetary features often come out with extreme sharpness of definition.

During daylight observations it will be found useful to insert between the lenses of a negative eye-piece, a thin disc of blackened metal or card, by way of a diaphragm, with an opening about half that usually placed there. This arrangement gives a deeper tone to the planet's image.

The number of features, all of interest, presented by *Saturn* renders this planet a standard one for popular observation.

As a rule the gauze ring must not be expected to be seen with any aperture below 4 inches.

As regards the satellites—any good telescope of 2ⁱⁿ aperture will show Titan; 3ⁱⁿ will sometimes show Iapetus; 4ⁱⁿ will take in Iapetus well, together with Rhea and Dione, but hardly Tethys; 5ⁱⁿ will show Tethys well; 6ⁱⁿ, Enceladus: but Mimas and Hyperion are beyond the reach of all but the largest instruments in existence. Fletcher saw Mimas with a glass of 9 $\frac{1}{3}$ ⁱⁿ aperture, but this is an exceptional case.

Fig. 146 represents the observations of N. E. Green between November 1884 and February 1885, and will be useful as suggesting to observers what to look for.

Mr. Green remarks that the outer ring **A** is the great difficulty of the planet, and requires very favourable circumstances for its

markings to be seen to advantage. The brightest portion is certainly on the side nearest to Cassini's division, but does not come close to it; whilst towards the exterior edge of the ring a faint line of light was to be seen. No indication of Encke's division could be detected at the epoch of the sketch.

Fig. 146.

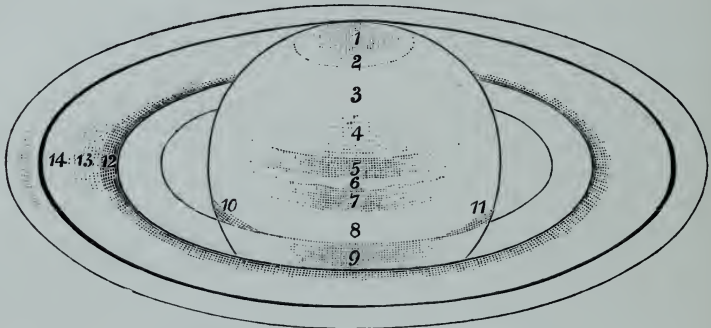

SKETCH PLAN OF SATURN. (N. E. Green.)

- | | |
|---|--|
| <ol style="list-style-type: none"> 1. South Polar cap, dark gray. 2. Very faint extension of the gray of pole, slightly yellower. 3. Broad band of yellowish-gray light. 4. Broad belt of slightly deeper colour. 5. A well-marked narrow dark-gray belt. 6. Very narrow belt of yellowish light, irregular in outline. 7. The darkest belt on the ball, colour warm gray. 8. Equatorial light, very bright in the centre. 9. The edge of the dusky ring, the shade of which is increased by a dark belt on the northern | <ol style="list-style-type: none"> side of the equatorial light. Portions of this belt are seen at 10 and 11; the resulting colour being a blue-gray darker than belt 7. 12, 13, 14. Three zones of the inner ring, commonly known as Ring B. Zone 12 is the narrowest of these zones; it fades gradually into the Dusky Ring C. Zone 13 is the broadest, and shines with a subdued yellow light. It is bounded distinctly by the bright zone 14, the most brilliant portion of the system. |
|---|--|

Respecting the movements of Jupiter's satellites, some facts summarised by Proctor will be useful for the guidance of amateur observers:—"In the inverting telescope the satellites move from right to left in the nearer parts of their orbits, and therefore transit Jupiter's disc in that direction, and from left to right in the farther parts. Also note, that *before* opposition, (1) the shadows travel *in front of* the satellites in transiting the disc; (2) the satellites are eclipsed in Jupiter's *shadow*; (3) they reappear from behind his *disc*. On the other hand, *after* opposition, (1) the shadows travel *behind* the satellites in transiting the disc; (2) the satellites are occulted by the *disc*; (3) they reappear from eclipse in Jupiter's *shadow* . . . The satellites move

most nearly in a straight line (apparently) when Jupiter comes to opposition in the beginning of February or August, and they appear to depart most from rectilinear motion when opposition occurs in the beginning of May and November. At these epochs **IV** may be seen to pass above and below Jupiter's disc at a distance equal to about $\frac{1}{6}$ of the disc's radius. The shadows do not travel in the same apparent paths as the satellites themselves across the disc, but (in an inverting telescope) *below* from August to January, and *above* from February to July.^r"

An attentive observer blessed with good eyes and a good telescope will frequently be able to detect colour on some of the planets, especially on Mars, Jupiter, and Saturn. But for this sort of work large apertures and high powers are indispensable. Browning states that colour on Mars and Saturn is best seen on nights somewhat misty, and with powers based on the ratio of 60 to every inch of aperture. Occasionally, however, much colour may be seen on a perfectly clear night; and a misty night may fail to cause an exhibition of colour—irregularities not readily susceptible of explanation.

Mr. I. Roberts, F.R.A.S., described to the Liverpool Astronomical Society in 1883 a very ingenious and useful piece of apparatus which he called a "Planet Indicator." It is intended to show at a glance the position with respect to the observer's meridian of the major planets at any moment. It consists of a series of circular discs each representing the orbit of one of the planets. They are made to revolve round a pivot which is their common centre, and attached to this centre is a brass disc which represents the Sun^s.

The following remarks by Challis^t on the subject of sweeping deserve a place here:—"In making use of an Equatorial in

^r *Half-hours with the Telescope*, pp. 86-8.

^s *Proc. Liverpool Astron. Soc.*, vol. i. p. 14. 1882-3.

^t *Lectures on Pract. Ast.*, p. 300. A very useful paper by Denning, containing Hints on the systematic searching for

comets, will be found in the *Observatory*, vol. v. p. 285, Oct. 1882. See also a method described by Wendell for determining by micrometer measurements plotted on paper whether a suspicious object is fixed or in motion. (*Ast. Nach.*, vol. cvii. no. 2533, Aug. 24, 1883.)

sweeping for an object recognisable by its physical aspect, such as a comet, or a nebula, the telescope should be clamped in R. A. at an arbitrary epoch so as to point considerably *westward* of the most probable hour-angle at that epoch of the object sought for, and be moved up and down on each side of the most probable circle of Declination, till the object is detected in the field of view by its appearance. If the object be a small planet not distinguishable in appearance from a minute star, and a probable place be given, the sweeping may be effected by noting down the places of all likely objects in contiguous zones of Declination of a certain length, the central point of the aggregate zone being the given place, and after a time sweeping over the same area, to see whether any star in it has changed position, or any new object has entered within its limits. To render this mode of sweeping sure and rapid, the instrument should be carried by clock-movement."

COMETS, CLUSTERS, AND NEBULÆ.

These objects, one and all, require low powers and low powers only. It may be taken as generally true that nothing beyond the 2 lowest of any series of 6 powers should be employed in their examination, for a certain proportion of *light* to *size* is essential to distinctness of vision; though by using an eye-piece of shorter focus (*i.e.* higher power) we can readily augment the size of the object, but we cannot increase the light afforded by the object-glass. Hence, in augmenting progressively our magnifying power a point is soon reached, at which the advantage of increased size is wholly neutralised by the dimness and indistinctness of the object, and as with few exceptions the brightest of nebulae are dim and indistinct compared with the larger planets, it will readily be understood why moderate powers are essential in the one case though not in the other.

Holden gives the following as a very rapid method of drawing nebulae^u:—Take a piece of glass ruled carefully into squares

^u Silliman's *Amer. Journ.*, 3rd Ser., vol. xi. p. 347. June 1876. But it does not

appear how these ruled squares are rendered visible in the unilluminated field.

and place this in the focus of the eye-piece so as to be plainly visible; then direct the telescope upon the nebula, and set going the clockwork motion of the telescope so that it follows the nebula accurately. Select one of the brighter stars which is in the field, and keep it by means of the clock-work accurately in the corner of one of the squares. A piece of paper ruled in squares similar to those of the glass reticle is provided, and on it the observer dots down the various stars in and about the nebulae. This may take 2, 3 or 4 nights, according to circumstances, but in all cases it requires much less time than micrometric measurements of the brighter stars and the troublesome allineations required to fix the positions of the smaller stars; and it has the great advantage that the work can be done in a perfectly dark field of view, whereas micrometric measures demand the use of illuminated wires. After the stars are inserted, the principal lines of the nebula are put in, not only by aid of the star groups, but also by the squares themselves. Holden says that for his own use he has had constructed two reticles: one ruled in squares like those seen in Fig. 30 (*ante*), and the other in which the heavy-lined large squares are still present, but are subdivided into small squares by lines parallel to their own diagonals. After making all the use possible of the first reticle, the second is put in, and an entirely new set of reference-lines is obtained, making an angle of 45° with the old set. This of course could be equally obtained by revolving the first reticle through an angle of 45° , but that is not quite so convenient a plan.

STARS, INCLUDING DOUBLE STARS.

Stars at low altitudes require a shorter focus than do stars at high altitudes, in order that there may be in both cases equal distinctness of vision^x.

^x With this note, which I believe is due to Dawes, accords an observation of Noble's to the effect that on one occasion during a haze he found the focus of his telescope become shorter by $\frac{1}{16}$ inch, a

state of things which ceased when the haze disappeared, the focus resuming its ordinary place. (But see *Month. Not.*, vol. xxvii. p. 282. June 1867.)

The only restrictions under which the observer of double stars will find himself depend upon the state of the air and the aperture of his telescope; subject to these, he may employ the highest powers he possesses. Using a telescope of 3ⁱⁿ aperture I have found 120 to be a very serviceable power for doubles whose components varied in distance between 3" and 12". For stars less than 3" apart, 240 was used when the atmosphere permitted, whilst stars wider than 12" looked prettier under powers lower than 120. The utmost I ever achieved with the above instrument (an excellent one, by Cooke) was to see the 3 stars of the Triple 12 Lyncis, the 2 nearest of which are only 1.6" apart.

In scrutinising difficult doubles, Sir W. Herschel's advice may be followed with advantage: he recommended that the focus should be previously adjusted upon a single star of nearly the same altitude, size, and colour, alleging that when this was done the peculiar aspect of the double star would afterwards more strikingly appear.

The principles and practice of the measurement of double stars involve too many technical matters to find a place here.

The reader who wishes to work at this subject and desires detailed information for his guidance should consult the authorities named in the foot-note^y.

With an E. wind the telescopic discs of stars often become most provokingly triangular. This may be stated most positively to be a matter entirely independent of the optical quality of the object-glass used. Dawes

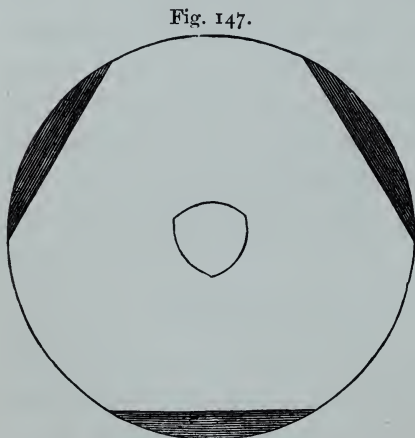

PLAN FOR CURING TRIANGULAR STAR-DISCS.

provided an effectual remedy by cutting off 3 equidistant

^y Crossley, Gledhill and Wilson, *Hand-book of Double Stars*, p. 64, and especially

the Hints on p. 83: Lockyer, *Stargazing*, p. 362.

segments from the whole aperture of the object glass. The base of each segment must be the chord of 60° . The chords being placed so as to coincide in position with the angles of the telescopic inverted image, those angles will be as it were clipped off and a fairly round image will be obtained. The form of the faulty image is usually somewhat that of an obtuse-angled spherical triangle^z.

Faint stars, and indeed faint celestial objects of any kind, will often be seen by viewing them from the side of the eye when direct vision fails to make them apparent. The cause of this is not clear, but the fact that this device is frequently successful when all others fail, admits of no doubt. When about to examine faint objects the eye should be prepared by undergoing a little preliminary training, such as is afforded by 5 or 10 minutes' rest in the dark: its discerning power will then be much strengthened.

The apparent inequality of the two components of a double diminishes as the light of the telescope is increased. Some observers find it convenient to set apart for the scrutiny, especially, of coloured doubles, of an eye-piece which has a narrow strip of tinfoil stretched across its field, and so permits the observer to block out one component: a better judgment can then be formed as to the other.

As to the separating power of telescopes of various apertures Dawes has given the following figures derived from an empirical formula of his own.

Aperture. inches.	Least separable distance. "	Aperture. inches.	Least separable distance. "
1.0	4.56	6.0	0.76
1.6	2.85	6.5	0.70
2.0	2.28	7.0	0.65
2.5	1.82	7.5	0.61
3.0	1.52	8.0	0.57
3.5	1.30	10.0	0.45
4.0	1.14	12.0	0.38
4.5	1.01	15.0	0.30
5.0	0.91	30.0	0.15
5.5	0.83		

^z *Month. Not.*, vol. xxvii. p. 232. April 1867.

He remarks :—" It might be not unreasonably imagined that the brightness of the stars would make a great difference in the central distance to which any given aperture could reach. But though it may make *some* difference, it is in fact far less than would at first sight appear probable. This arises from the much higher powers which the brighter star will bear; and as the diameter of the discs does not increase in proportion to the power, the separability of a magnitude is nearly the same, provided the state of the air is such as to bear well the increase of power^a." The formula on which the above table is based is—

$$\text{Separating power in seconds of arc} = \frac{4.56}{\text{aperture in inches.}}$$

It often happens that a smaller aperture will show a very delicate and close companion to a bright star when a larger aperture fails to show it.

Some nights are more favourable than others for the discrimination of minute differences of colour in stars. Differences of atmospheric condition are no doubt the cause of this, and indeed, if we were better acquainted than we are with the influences of the atmosphere on astronomical optics, it is probable that many discordances and contradictions that have been noted by observers would be reconciled.

With respect to the observation of stars for the purpose of taking notes of colour Webb makes some remarks and suggestions which deserve a place here :—" It may often be found of service to put the object considerably out of focus either way, as the hue of a disc may be more sensible than that of a point; and we may thus in some cases escape errors due to the imperfect achromaticity of the object-glass, which will not be equally apparent on each side of the focus, of which I have had experimental certainty. It is safest to estimate the tint in the centre of the field as the Ramsden ocular [*i. e.* eye-piece] is never achromatic, and other eye-pieces claiming that quality do not always possess it. A state of atmosphere in which the Sun would have a ruddy

^a *Mem. R. A. S.*, vol. xxxv. p. 159. 1867.

cast ought of course to be avoided, and colours cannot be depended upon in our climate and under ordinary circumstances within some distance of the horizon, as they are interfered with by the refractive action of the atmosphere. 'In addition,' Smyth tells us, 'to the colouring and absorbing effect of the atmosphere increasing so excessively low down on the horizon, the envelope acts so strongly there as a prism, that combined with the bad definition prevailing, I have sometimes seen a large star of a really white colour appear like a blue and red handkerchief fluttering in the wind; the blue and red about as intense and decided as they could well be.' W. Struve found these prismatic colours visible in a dark field as far as 30° and their traces even to 45° from the horizon, and every estimate below 15° was worthless. The same authority has stated that the tints are not to be trusted on the blue background of a day-light sky. In fact, every deception arising from contrast ought to be guarded against, and this source of error operates in more than one way. A retina which has recently been exposed to artificial light, hardly ever of a pure white, will require to be kept in the dark for a little time in order to pass an unbiassed judgment; and the presence of a large and strongly-coloured star in the field will be sure to tinge its feebler neighbours with the complementary hue: and this may no doubt be to a certain extent the reason why so many minute companions to orange or yellow stars have been entered as blue, but it is certainly not the sole cause^b." To these remarks I may add that in examining double stars in order to assign colours to them it is expedient not to employ a higher magnifying power than will suffice to separate the components; as high powers are liable to bring out any uncorrected colour, and so to bias the eye.

The amateur astronomer who commences anything like systematic observations of the fixed stars, will find himself confronted by a difficulty which really involves points of such moment that it is surprising that so few attempts have ever been made to

^b *Student*, vol. v. p. 487.

grapple with it. I am alluding to the estimation of star magnitudes, sometimes, rather pompously, talked about as "Stellar Photometry." The vagueness of language in use respecting star magnitudes is as surprising as it is unsatisfactory, and when one considers the precision which characterises modern science, one is astonished that so little has been done to remove it. I do not think it too much to say that *estimates of star magnitudes not based on methodical experiment are rarely trustworthy*; and this often applies even to statements made by experienced observers.

To Dawes is mainly due the credit of initiating a genuine reform as to this matter. *The principle* of his suggestion is to diminish the light of the stars examined so as to reduce them to some common standard of brightness. This is done (1) by diminishing the aperture of the telescope employed till the star under comparison becomes barely but steadily visible; and (2) to take as the standard aperture that which just secures visibility to the average of several of Argelander's stars of the 6th magnitude. "Assuming, then, the obvious principle that if two stars, as viewed through a telescope, appear equally bright, the illuminating powers employed (that is, the areas of the portions of the object-glass employed) must be inversely proportional to their magnitude or real brightness, it is easy to calculate the areas of the portions that must be left exposed to render *just* visible the stars arranged according to a definite scale of magnitudes," and to provide by means of the formula given a series of pasteboard rings that can be readily numbered and applied to any particular telescope. To put this idea into practice the first thing that an observer must do is to determine experimentally for himself what is the aperture of the telescope he uses which will give the desired visibility to average stars of the 6th magnitude, and thence to determine the apertures corresponding to smaller magnitudes. Of course in obtaining the standard of aperture for an average 6th magnitude star (on which the other apertures depend) reliance must not be placed on one star only; at least a dozen should be made use of.

In working out this matter Dawes stated that he had intended

to adopt Sir J. Herschel's scale, as generally avoiding the use of half-magnitudes, but that eventually he decided to conform Struve's ratio of progression in order that his results might be comparable with those obtained by such leading observers as La Lande, Piazzini, Bessel, and Argelander.

Putting m = the standard magnitude ; a the aperture necessary to show it ; μ = any other inferior magnitude, and x = the aperture necessary to render visible a star of magnitude μ , we shall obtain the equation:—

$$x = a \times 2^{\mu - m}.$$

Of course one and the same power must be used invariably in operating with a series of apertures thus obtained.

When the apertures corresponding to each magnitude and half-magnitude have been thus ascertained by calculation, a series of discs must be prepared and pierced as may be requisite. Many persons will be able to do what is necessary themselves, but if not, the assistance of an instrument-maker must be sought^c.

Dawes, by making a trifling addition to his solar eye-piece, succeeded in converting that into a useful instrument for determining the brightness of stars of unknown magnitude. He had fitted to it sliding wedges of neutral-tint glass of different depths of shade. A wedge is first used on some star assumed to be of a definite recognised magnitude and therefore available as a standard. The wedge is moved across the eye-piece and adjusted so that the star is just visible and no more. The position of the wedge relative to some zero point on the eye-piece is then marked. Supposing now that the star observed was of the 8th magnitude ; any other unknown star which is similarly visible with the wedge in the same position would also be of the 8th magnitude, and so on with other magnitudes as experiment might show, marks applicable to the different magnitudes being made on the wedges.

This wedge arrangement combined with a "Dawes's Solar Eye-piece" offers great facilities for the determination of the

^c See *Month. Not.*, vol. xi. p. 187. vol. xiii. p. 277. 1853. For an account of
June 1851 ; vol. xii. p. 80. Feb. 1852 ; the "Wedge Photometer" see p. 188 (*ante*).

magnitudes of the components of double stars—a matter otherwise of no small difficulty. By having resort to the smaller holes in the diaphragm as may be found convenient, it is possible to isolate one star of a pair from its companion and gauge its light with certainty. This done, the resulting values will be sometimes very different from, and always much more trustworthy than, ordinary eye-estimations. For instance, Dawes stated that there resulted a difference of more than a whole magnitude of Struve's scale in his estimation of the brightness of the small companion to α Lyrae according as the principal star was or was not visible at the time when an observation was made ^d.

Whilst on the subject of star magnitudes it may be well to present the reader with a useful Table of comparative magnitudes, given by Webb^e at the instance of Knott. It represents in terms of Smyth's magnitudes the equivalent magnitudes of Sir J. Herschel, W. Struve, and Argelander. The fact that Smyth's values are based upon Piazzi's is deemed by Webb, and I think justly, an additional reason for putting them to the front, but it is impossible to deny that Struve's values (based on the scale of 1-12 for stars visible in the great Dorpat refractor) have met with much acceptance both in England and on the continent. The Table is restricted to telescopic magnitudes, there being a fair agreement as regards stars visible to the naked eye.

Smyth.		J. Herschel.		W. Struve.		Argelander.
6	=	6.4	=	5.7	=	5.9
6.5	=	7.0	=	6.3	=	6.4
7	=	7.4	=	6.5	=	6.8
7.5	=	7.8	=	6.9	=	7.5
8	=	8.2	=	7.4	=	8.0
8.5	=	8.8	=	7.9	=	8.6
9	=	9.5	=	8.3	=	9.0
9.5	=	10.1	=	8.9	=	9.4
10	=	10.4	=	9.3	=	9.4
11	=	11.3	=	10.0	=	10.0
12	=	11.7	=	10.4	=	10.6
13	=	12.5	=	10.7	=	11.2
14	=	13.3	=	10.9	=	11.8
15	=	14.5	=	10.9	=	12.4
16	=	15.9	=	10.9	=	13.0

^d *Month. Not.*, vol. xxv. p. 230. June 1865.

^e *Celest. Objects*, 4th ed., p. 207.

The observation of variable stars is quite a trade by itself, demanding as it does great care, patience, and experience ^f.

Pickering has thus pointed out what amateurs, and especially ladies, can do in the observation of variable stars:—"The aid of amateurs is especially invited, since the necessary skill is soon acquired, and the habit of making observations of permanent utility would often have a value as great as the direct results anticipated. The aid of lady observers is also desired, since much useful work could be done by them at their own homes. Among the many ladies owning telescopes are doubtless some who have the time and inclination, and might, if properly directed, make observations of great value to science ^g."

MISCELLANEOUS REMARKS.

Be content in general to use low powers. Much time and patience are often wasted in hopeless endeavours to bring out with high powers details which will not come out because the atmosphere is unfavourable, or the object-glass inferior, or the observer's eye out of condition. High powers are also objectionable because they diminish the field of view and the illumination of the object under examination, magnify the speed with which the diurnal motion causes an object to pass out of the field, and exaggerate all imperfections of lenses, stands, and of the atmosphere.

The best kind of light for use in an observatory (or for astronomical purposes out of it) is that which is afforded by a bull's-eye lantern, as by means of it you can throw the light on your books or maps without materially distracting the eye. Such a lantern is especially desirable for reading graduated circles, as it concentrates the light where much is wanted, and shields the eye from the direct rays of light. Where much reading of circles has to be accomplished, it is a great convenience to have them illuminated by a lamp fixed (and masked) so as to leave both the

^f For some hints see a French translation of a paper by Argelander, in *L'Astronomie*, vol. vi. p. 288.

^g *37th Annual Report, Harvard Coll. Obs.*, 1883, p. 13.

observer's hands free. Gas has much to recommend it on the score of cleanliness and saving of time and trouble, but the excessive heat which it gives out produces so many currents of air that even with the utmost precautions as to ventilation annoyance will be experienced by the spoiling of the definition. A red shade, consisting either of tinted glass or of red silk tied over the bull's-eye of the lantern, is useful when the observer is passing from the examination of a map or book to that of a delicate object; as the eye is less tried by the red than by the white light.

The light for illuminating the wires of the transit instrument or of the micrometer, as the case may be, should enter through a piece of red glass, for red affects the eye the least of all colours; and the observations will be much more trustworthy if made with the minimum amount of light which will permit the wires and the star to be clearly seen.

The most convenient kind of coat for an observer is a common shooting coat (in summer), as its front pockets are very useful as receptacles for eye-pieces and so forth. For winter wear an "Ulster." As regards head-gear, nothing is better than a simple skull-cap without peak or brim of any kind. I have long used a Turkish fez, but it is rather hot in summer weather. Smyth recommends cloth boots to keep the feet and legs warm in winter.

Nights on which stars shine brightest to the naked eye are frequently of little value for astronomical observation, whilst hazy dull-looking nights often enable important features to be brought out; this is specially the case with the larger planets^h.

When a bright object approaches from outside the edges of the field of view, the more suddenly it does so, the finer the condition of the sky for work.

As regards the number of nights in the year available for telescopic work, perhaps it would not be very profitable to attempt to say much. Mr. W. Lawton, from observations at Hull extending over 22 years, found the number of nights cloudless, or nearly so,

^h A striking instance of the truth of this is furnished by the history of the discovery of Saturn's dusky ring. The

night on which G. P. Bond found it was so hazy that none but bright stars were visible to the naked eye.

up to midnight, to range, omitting fractions, from 7 for January, February, July, and December, to 9 for May, June, September, and October, the most cloudless month being April with 10 nights. March, August, and November each yielded 8 nights apiece. This reckoning takes no account of quality, only of freedom from cloud. Moreover, much depends on the position of an observing station and on its surroundings; also on its height above the sea-level.

Sir J. Herschel recommended the use of a round disc of thin metal or card-board, placed centrally in front of the object-glass, and having a diameter of from $\frac{1}{6}$ to $\frac{1}{5}$ that of the object-glass. This increases the *separating* power of a telescope, but as it also augments both the number and the sizes of the rings round bright stars, its value on the whole is somewhat dubious.

Dawes adopted and recommended the practice of covering the entire object-glass with perforated card-board, such as that employed in Berlin wool-work. The effect of this expedient in producing sharpness of definition he considered to be very marked. When the object to be viewed was not bright enough to bear the loss of light thus arising, he found that something like the same good results might be obtained with a piece of card-board of the size of the object-glass pierced with holes of equal size (about $\frac{1}{5}$ of an inch in diameter) arranged in concentric circles.

In operating with a telescope which is not very steady on its stand, it is a good plan to direct the instrument not on to the object you want to see but towards a point one or two fields *preceding* it, and await the passage of the object (by the diurnal motion) across the field. Proceeding thus, the tremors of the telescope have a little time to settle down, and the scrutiny may eventually be performed under more favourable circumstances than would otherwise be possible.

Those who specially desire to devote themselves to the delineation of celestial objects, will do well to study a useful paper on *Astronomical Drawing* written many years ago by Professor C. P. Smyth¹.

¹ *Mem. R.A.S.*, vol. xv. p. 71. 1846.

Methodical astronomical observation will be greatly facilitated by the employment of printed forms on which to record the results arrived at. I append 2 such forms (see opposite), which I have found very useful in their respective departments.

No. 1 requires no explanation. [See p. 118 *ante*.]

No. 2 will be found to conduce greatly to the economy of time on a good night. All the observer has to do is to write out in the day-time the objects which he wishes to examine, with their positions (corrected for precession if needful^j) accompanied by a *précis* of their striking features; then when evening arrives he is ready for action without the mortification of losing half of a valuable night in deciding what to look for, and in rummaging over a dozen books to acquaint himself with the whereabouts of what he desires to look for. The observer's own notes are to be set down in the last column, and may be transcribed at leisure.

HINTS TO OBSERVERS BY THE LATE

ADMIRAL W. H. SMYTH.

The paragraphs which follow to the end of this chapter are selected from a sub-section of Admiral Smyth's *Cycle of Celestial Objects* (vol. i.), which bears the title of "Hints to Amateur Astronomers." They will be found, perhaps, to clash here and there with remarks and suggestions which I have already made, but the Admiral's style of writing was so especially pleasant to read, and withal, the matter was so practical and judicious, that a little repetition, if repetition there be, will assuredly be pardoned by the reader:—

"The *furor* of a green astronomer is to possess himself of all sorts of instruments—and to make observations upon everything—and attempt the determination of quantities which have been again and again determined by competent persons, with better means, and more practical acquaintance with the subject. . . .

"Individual observers would be most likely to advance the cause of astronomy substantially by giving their undivided attention to a particular object. . . .

"Those individuals who fear that their instruments are not of sufficient power to render their observations useful, should remember that Galileo's grand discoveries were made with a telescope that magnified only 30 times. . . . It is the mind which stamps a value upon the observations: for attention, habit of precision, good sight

^j But this will rarely be needful unless very old catalogues are used.

1. FORM FOR STAR TRANSITS.

No. _____	Date _____
Star _____	Decl. _____
Wire I. 	m. s.
II. 	
III. 	
IV. 	
V. 	

	_____ .2

	Mean wire _____
	h. _____
Observed passage	
R.A. of star 	_____
Clock error 	_____

2. FORM FOR OBJECTS TO BE OBSERVED.

No. _____	Date _____			
Object,	R.A.	Decl.	Memoranda.	Remarks.
	h. m. s.	° /		

and hearing, and earnest perseverance are qualities in the observer as important as the comparative excellence of his instrument. A man may prove a good astronomer without possessing a spacious observatory: thus, Kepler was wont to observe on the bridge at Prague; Schröter studied the moon, and Harding found a planet, from a *gloriette*; while Olbers discovered two new planets from an attic of his house^k. . . .

“He who diligently applies himself may always accomplish much good and acceptable work. . . .

“Many things deemed invisible to secondary instruments are plain enough to one who ‘knows how to see them.’ . . . The observer will soon practically comprehend that aphorism of Sir William Herschel’s which states, ‘It should be remembered that when an object is once discovered by a superior power, an inferior one will suffice to see it afterwards.’ . . .

“There are several obvious methods of ascertaining whether the object-glass is good; but one of the best proofs of excellence is in the instrument’s coming briskly to a focus, for where the eye-pieces can be played in or out without sensibly altering the distinctness of vision, it may be suspected that the spherical aberration of the transmitted rays is not duly corrected. The achromatism, which depends on both material and workmanship, is examined by pushing in or pulling out the eye-piece from the point of distinct vision, when the telescope is placed upon a proper object, till the appearance of the central tints of the prismatic spectrum—in the first case purple, and in the latter light green—shows that the extreme colours are corrected. The accuracy of the curvature of the lenses, and the homogeneity of the glass, will be proved by the fidelity of form in the objects looked at, the absence of dispersed light and *wings* to the stars, and the tone of the irradiations which may interrupt the rings surrounding the spurious discs of large stars under high magnifying powers. These experiments can be made by daylight on a printed card, a watch-face, or any strong contrasting marks of a light object on a dark ground; by night the telescope may be directed to the edge of the moon, or to Jupiter, for testing the production of the purple and green fringes just mentioned. The ghost, or secondary spectrum, will more or less haunt most of such instruments, nor can it be exorcised until perfection of figure can be ensured to the lenses; such shadow being imputable to the different refracting media not exerting the same proportional power upon all the coloured rays. In making these trials the whole range of eye-pieces, positive, negative, and single-lens, may be brought into play, in order to judge of the degree of irradiation, and the effect of the interference of the rays which graze the edge of the aperture, under each. But one of the most effective means of testing the goodness of a telescope, is afforded by the double stars, which offer a more precise and sensible test than the planets: and a statement of the magnifying power under which a telescope will separate certain specified objects, is at once a tolerable scale by which to estimate its performance. . . .

“For general gazing, he may watch for proper weather, of which he will find more than he expected, and quite as much as he wants, if he reduces his observations, or follows a formal plan. It is true that Sir William Herschel said, ‘it appears that a year which will afford ninety or at most one hundred hours, is to be called a very productive one;’ but he meant such as are fit for magnifying one thousand times with his 40^{ft} reflector of 4^{ft} aperture, which would only be eligible when the star is half way to the meridian, and the sky perfectly serene and diaphanous.

^k As did Hermann Goldschmidt in the environs of Paris.

I should say that where a person will look out for opportunities in the mornings as well as evenings, and especially between midnight and daybreak, he will find that nearly half the nights in the year may be observed in, and of these 60 or 70 may be expected to be splendid. *Completely* pure nights, however, with the absence of moon, twilight, wind, and mist, are of rare occurrence; and when they do happen, ought always to be 'used up.' During 61 days in every year, it is idle to look for high-class nebulae, on account of there being, properly speaking, no night. The sun's midnight depression on the longest day for Greenwich is 15° . Now the secondary illumination called twilight lasts till that luminary is 18° below the horizon: consequently, while it has $20^{\circ} 28'$ of North declination, and is therefore within this distance, we have no actual night. Such is the case from the 22nd of May to the 21st of July¹. Light haze sometimes accompanies the finest evenings; but many of the nights in which the stars appear visible to the naked eye are useless under the instrument. The climate of England has been railed at without mercy, but I can assure the tyro that when the nights are favourable, they are fine indeed; and by the exertion of a little moral courage he will surmount many of the atmospheric inconveniences.

"As far as he possibly can, the amateur should always keep his instrument clean and fit for use; and he will prudently avoid any unnecessary expenditure of time and temper, if he occasionally sees that the finder is in good adjustment, so that a star on its cross wires will be at or near the centre of the greater object-glass. Without being one of the dabblers before alluded to, he will of course know so much of telescopic construction, and the general laws of the refraction and dispersion of light, as to be able to replace properly the lenses of compound eye-pieces after cleaning them: to prevent mistakes on such an occasion, I would recommend that only one glass be taken out at a time, and that it be replaced before another is removed^m. . . .

"In placing eye-pieces into their station, no screwing should distract the attention of the observer; they should each be fitted to adapters, or short sliding pieces of tube, by which they may be readily shifted without delay, or shaking the instrument. It will also conduce to order, and save them from dust, if each eye-piece is provided with a brass cap, also to slip, and be placed thereon when not in use; and the magnifying power of each may be engraved, both on the eye-piece and its cap.

"But in advocating a strict attention to keeping clean the eye-pieces, and the outer surfaces of the object-glass, let me warn the observer never to disturb the latter in its cell. The centering of the flint and crown discs is so critical a point in both the spherical and chromatic corrections, that, except in cases of extreme necessity, it should not be disturbed unless by the hand of the artist who made it. Every precaution should be taken to keep damp from penetrating between the two glasses, to prevent the 'sweat,' or arborescent vegetation which shoots between the surfaces in neglected telescopes. It is even better to let that evil flourish than disturb the lenses, for it will be some years before its growth interferes with the general action of the

¹ The co-latitude of Greenwich $38^{\circ} 31' 21.9''$, and the obliquity of the ecliptic for 1840, $23^{\circ} 27' 37''$, give $15^{\circ} 4' 9.1''$ for the solar depression.

^m Whether by design or not, the mechanicians only know: but it so happens

that quadrant and sextant cases are all furnished with that tempting object to the "over handy," the screw-driver. Hence the number of instruments that return from on board incurable.

instrument by a deterioration of its light-transmitting properties. This is a point upon which I warn the class whom Troughton named 'the over-handly gentlemen,' who in their feverish anxiety for meddling with and making instruments, are continually tormenting them with screw-drivers, files, and what not^m. If the tube be left exposed to the weather after the observations are over, the object-glass should be carefully taken out, and deposited in safety: in replacing it, let the air pass through the tube, by drawing the hands down its outer surface two or three times. . . .

"When about to observe, avoid bright and stimulating objects for a few minutes, so that the pupil of the eye may be dilated, and the sensibility of the visual organ increased: and as little light as possible should be used in readings, &c., in order to prevent the adjustments of the eye from being disturbed. It is best to use, or at all events to begin with, moderate powers, but not so small as to have the emergent pencil larger than the pupil of the eye; . . . after finding the object with the lower eye-pieces, the power may be raised as high as the instrument and existing state of the atmosphere will bear. But it must be kept in mind, that in using high powers, the light is lessened in the inverse ratio of the square of the power; and where the force is augmented out of due proportion, it requires both judgment and perception to get a firm glimpse. The illuminating power being as the square of the diameter of the aperture, affords an index to the capacity of the instrument: and this established, a convenient working eye-piece ought to be applied. Every increase of power diminishes the field, and darkens the object, while tremors of all kinds are increased, motion being magnified as well as matter, and the limited excitability of the eye is severely taxed. Some of the closer double stars, however, require to be highly magnified to enable a spectator to separate them; and stars of the greater magnitudes with minute companions are difficult, because the brightness of the large one stimulates the eye and contracts its pupil. It requires pretty high powers also to be satisfied as to the colours of a pair of stars, whether they are inherent or complementary; the last being those colours at equal distances from the opposite end of a prismatic spectrum. This, however, is a point on which satisfaction is hardly attainable."

CHAPTER IX.

HISTORY OF THE TELESCOPE.

Early history lost in obscurity.—Vitello.—Roger Bacon.—Dr. Dee.—Digges.—Borelli's endeavour to find out who was the inventor.—His verdict in favour of Jansen and Lippersheim of Middelburg.—Statements by Boreel—Galileo's invention.—Scheiner's use of two double-convex Lenses.—Lenses of long focus used towards the close of the 17th century.—Invention of Reflectors.—Labours of Newton.—Of Halley.—Of Bradley and Molyneux.—Of Mudge.—Of Sir W. Herschel.—Of the Earl of Rosse.—Of Mr. Lassell.—Improvements in Refracting Telescopes.—Labours of Hall.—Of Euler.—Of the Dollonds.—The largest Refractors yet made.

THE early origin of the telescope, like that of many other important inventions, is lost in obscurity, and it is now impossible to determine who was the first maker. It is certain that some time prior to the end of the 13th century lenses were in common use for assisting to procure distinctness of vision. A certain Vitello, a native of Poland, seems to have done something in this line; and Roger Bacon, in one of his works, employs expressions which show that even in his time (he died in 1292) spectacles were known^a.

Seeing that this was the case, it is almost certain that some combination of 2 or more lenses must have been made in the interval which elapsed between Bacon's time and the commencement of the 17th century, when telescopes are usually considered

^a *Opus Majus*, part iii. cap. iv. p. 357, ed. S. Jebb, fol. London, 1773. Layard discovered at Nimroud a plano-convex lens of rock crystal; hence it has been

inferred that the Assyrians possessed some knowledge of optics and of the phenomena of refraction.

to have been invented. Dr. Dee^b mentions that though some skill is required to ascertain the strength of an enemy's force, yet that the commander of an army might wonderfully help himself by the aid of "perspective glasses," a phrase which must refer to some kind of optical instrument then in use. The well-known old philosophical writer, Digges, states that "by concave and convex mirrors of circular [spherical] and parabolic forms, or by paires of them placed at due angles, and using the aid of transparent glasses which may break, or unite, the images produced by the reflection of the mirrors, there may be represented a whole region; also any part of it may be augmented, so that a small object may be discerned as plainly as if it were close to the observer, though it may be as far distant as the eye can descrie^c."

A second edition of Digges's work, edited by his son, was published in 1591, in which the latter affirms that "by proportional mirrors placed at convenient angles, his father could discover things far off; that he could know a man at a distance of 3 miles, and could read the superscriptions on coins deposited in the open fields." Though these statements may be exaggerations, yet it cannot be open to doubt that some kind of optical instruments were known to the writer in question.

A claim to the invention of the telescope has been put in on behalf of Baptista Porta, who lived between 1545 and 1618; it is probable, however, that all he noticed was, that an object viewed through a convex lens was apparently enlarged in size.

Towards the middle of the 17th century, Borelli, a Dutch mathematician of some repute, published a book^d containing the result of inquiries carried on by him for ascertaining what he could connected with the invention of the telescope. He decides, on the whole, in favour of Zachariah Jansen and Hans Lippersheim, two spectacle-makers of Middelburg, Holland. In a letter written by Jansen's son, the date of the discovery is stated to have been 1590, though another account makes it 1610. In the same work is given a letter, written by M. Boreel (Dutch

^b Preface to Euclid's *Elements*, 1570.

^c *Pantometria*, 1571.

^d *De Vero Telescopii Inventore*, 4to. Hagæ, 1665.

minister at the Court of St. James's), who mentions that he was acquainted with the younger Jansen, and often heard of his father as the reputed inventor of the *microscope*, adding that telescopes were first made in 1610 by Jansen and Lippersheim, who presented one to Prince Maurice of Nassau, by whom they were desired to keep secret their discovery, as he thought he might, by means of one of these instruments, obtain advantages over the enemy, Holland being then at war with Spain.

Boreel further mentions that Adrian Metius and Cornelius Drebbel went to Middelburg and purchased telescopes from Jansen. The account of Descartes differs from this. He says^e that about 30 years previous (to 1637, when his book was published), Metius, who was fond of making burning-glasses, by chance placed at the end of a tube 2 lenses, the one thicker and the other thinner in the middle than at the edges, and thus formed the first telescope. It is now impossible to reconcile these discrepancies. Harriot observed the Sun with a telescope in the year 1610, as we learn from his papers, edited and published^f by Professor Rigaud, but there is no evidence to show whether it was of English or foreign construction.

Whatever may have been the exact period^g at which the telescope was invented, certain it is that the knowledge of it was for some time confined to northern Europe. Galileo knew nothing of it until 1609, when he casually received some information on the subject from a German whom he met at Venice. He mentions that he then desired a friend at Paris to make certain inquiries for him. On receiving some information to guide him, he was enabled to contrive a telescope on the principle already referred to, magnifying no less than 3 times! He subsequently made one which magnified 30 times. The fruits of this discovery are well known, and include spots on the Sun, the satellites of Jupiter, the phases of Venus, &c.

^e *Dioptrica*, cap. i.: Lugduni Bavorum, 1637.

^f In the *Miscellaneous Works and Correspondence of the Rev. James Bradley*, 4to., Oxford, 1833, Suppl. p. 31.

^g Some further information concerning the Dutch origin of the telescope will be found in the *Sidereal Messenger*, vol. ii. p. 266. Dec. 1883.

Though a telescope made on this principle is exceedingly defective for viewing distant objects, on account of the small field which it embraces, yet some years elapsed before any improvement was made.

Kepler first pointed out the possibility of forming telescopes of 2 convex lenses^h, but he did not reduce his idea to practice, neither was it done for many years afterwards. Scheiner, in 1650, described an instrument of this kind, adding that he showed one to the Archduke Maximilian 13 years previouslyⁱ, and that the images were inverted. About this time De Rheita constructed telescopes of 3 lenses, which combination he stated gave a better image than 2; he also made binocular telescopes, instruments having 2 tubes side by side, and furnished with similar magnifying powers. I have already spoken of chromatic aberration, and of the immense focal length of some of the lenses used for telescopes. This was towards the close of the 17th century. Campani of Bologna, in 1672, made for Louis XIV. a telescope, the focal length of whose object-lens was 136^{ft}; Auzout had one 600^{ft}, but it seems that he was unable to use it, and no wonder. Huygens presented one to the Royal Society which had a focus of 123^{ft},^j and which is still preserved by that body. Practical astronomy is indebted to Huygens for the Negative Eye-piece—a most valuable invention.

The extravagant lengths which the dioptric telescopes had now reached resulted in attempts being made to see whether an equal magnifying power could not be attained in some other manner.

Mersenne, in 1639, suggested the employment of a spherical reflector for forming an image which might be magnified by means of a lens. Descartes, to whom the proposal was submitted, ridiculed it, and in consequence (we may presume) the idea was dropped. However, in 1663, Gregory renewed it (though it does not appear that he had any previous knowledge of what

^h *Dioptrica*, cap. i.: Lugduni Batarum, 1637.

ⁱ *Rosa Ursina*, &c.

^j *Astroscopia Compendiaria*: Hagæ, 1684. An engraving of one of these

extraordinary erections will be found in Simms's *Achromatic Telescope*, p. 9. That it could have been of any use seems incredible.

Mersenne had proposed), using, instead of a spherical, a paraboloidal speculum. He came to London for the purpose of getting an instrument of the kind constructed, but not finding any workman who could do it, he was obliged to relinquish the project.

Shortly after, Newton, believing that it was impossible to overcome the aberration caused by the unequal refrangibility of the different coloured rays of light, gave up the hope of constructing refracting telescopes which were likely to be of any great use, and turned his attention to the manufacture of reflectors. Having in 1669 found an alloy which he thought would be suited for a speculum, he cast one and ground it with his own hands, and early in 1672 he completed 2 telescopes, a detailed account of which he transmitted to the Royal Society^k. The radius of the concavity of the one was 13ⁱⁿ, and its magnifying power, 38. In the same year that Newton finished his telescopes, Cassegrain proposed the arrangement which now bears his name, though it does not appear that he actually constructed a telescope. The first reflecting telescope, the speculum of which was pierced in the centre so as to permit objects to be viewed by looking at them directly, was made by Hooke in 1674^l.

Very little progress was made in the improvement of reflecting telescopes for many years, in consequence of the difficulty of obtaining metal suitable for specula. In 1718 Hadley made 2, each 5^{ft} long^m; and Bradley and Molyneux, in 1738, succeeded in making a satisfactory oneⁿ, and having instructed two London opticians, Scarlet and Hearne, they made some for general sale. Short and Mudge were also labourers in this field^o. They were soon followed, and completely eclipsed, by Dr. (afterwards Sir William) Herschel^p. During the last half-century the Earl of Rosse^q, Mr. De La Rue, Mr. Lassell, Rev. H. C. Key, and Mr. With are those who have in England done most to improve the mirrors of reflecting telescopes.

Though the above improvements were progressively made in

^k *Phil. Trans.*, vol. vii. p. 4004. 1672.

^l Birch, *Hist. Roy. Soc.*, vol. iii. p.

122.

^m *Phil. Trans.*, vol. xxxii. p. 303. 1723.

ⁿ Smith's *Opticks*, vol. ii. p. 302.

^o *Phil. Trans.*, vol. lxxvii. p. 296. 1777.

^p *Ibid.*, vol. lxxxv. p. 347. 1795.

^q *Ibid.*, vol. cxi. p. 499. 1850.

reflecting telescopes, it must not be supposed that attempts to obtain achromatic combinations of glass lenses were abandoned. In 1729, Mr. Chester More Hall, of More Hall near Harlow, Essex, being of opinion that an examination of the physical constitution of the eye would afford some clue to the best means for forming achromatic combinations of lenses, set to work, and at length succeeded in obtaining the much-desired result—an image free from colour. Several persons are said, towards the close of the last century, to have possessed telescopes made by, or under the superintendence of, Mr. Hall^r, who, however, took no steps to make his discoveries generally known.

In 1747 Euler formed the same opinion as Hall, but did not obtain the same successful results. He proposed to employ a lens compound of glass and water, but it was a signal failure^s.

Dollond in 1758 invented the achromatic combination now in use, for which he received from the Royal Society the Copley Medal; and in 1765 his son, Peter Dollond, found that spherical aberration could be diminished by using 3 lenses of different kinds of glass^t.

Since this period great advances have been made in the manufacture of telescopes, more especially in respect of the size and purity of the glass employed^u.

Amongst the observatories possessing refractors of the largest size, that is instruments with object-glasses of 12ⁱⁿ and upwards in aperture, may be mentioned:—

Name of Observatory.	Aperture. Inches.	Maker of object-glass.
Lick Observatory, Mount Hamilton, California, U.S.	36.0	A. Clark & Sons.
Pulkowa, Russia	30.0	A. Clark & Sons.
Nice, Italy	29.9	Henry.
Paris... ..	28.9	Martin.

^r *Gent. Mag.*, vol. lx. part ii. p. 890. 1790; and see a paper by Wackerbarth in *Month. Not.*, vol. xxviii. p. 202, May 1868; and a paper by Ranyard in *Month. Not.*, vol. xlvi. p. 460, June 1886.

^s *Transactions of the Berlin Academy.* 1747.

^t *Phil. Trans.*, vol. l. p. 733. 1758.

^u For the latest information concerning the equipment of some of the largest and best modern observatories, see a *Report to the Secretary of the Navy on recent Improvements in Astronomical Instruments*, by S. Newcomb, Washington, U.S., 1884.

Vienna	27.0	Grubb.
Washington, U.S.	26.0	A. Clark.
Leander McCormick Observatory, Virginia, U.S.	26.0	A. Clark.
Mr. R. S. Newall's, Gateshead ^x	25.0	Cooke.
Princeton, New Jersey, U.S.	23.0	A. Clark & Sons.
Mount Etna, Sicily	21.8	Merz.
Strassburg	19.1	Merz.
Milan	19.1	Merz.
Chicago	18.5	A. Clark.
Warner Observatory, Rochester, New York, U.S.	16.0	A. Clark & Sons.
Washburn Observatory, Madison, Wisconsin, U.S.	15.5	A. Clark & Sons.
Edinburgh	15.1	Grubb.
Brussels	15.0	Merz & Son.
Madrid	15.0	Merz.
Rio Janeiro	15.0	
Paris	15.0	Lerebours.
Dr. W. Huggins's, Tulse Hill	15.0	Grubb.
Paris	15.0	Henry.
Bordeaux	14.9	Merz & Son.
Nice, Italy	14.9	Henry.
Pulkowa, Russia	14.9	Merz & Mähler.
Harvard College, Cambridge, Mass., U.S. ...	14.9	Merz & Mähler.
Lisbon	14.6	Merz & Mähler.
Hamilton College, Clinton, New York, U.S. ...	13.5	Spencer & Eaton.
Colonel Cooper's, Markree, Sligo	13.2	Cauchoix.
San Fernando, Cadiz	13.0	Brunner.
Mr. Rutherford's, New York, U.S.	13.0	Rutherford and Fitz.
Allegheny, Pennsylvania, U.S.	13.0	Fitz.
Dudley Observatory, Albany, U.S.	13.0	Fitz.
Greenwich	12.8	Merz.
Lyons	12.7	Henry.
Algiers	12.5	Henry.
Ann Arbor, Michigan, U.S.	12.5	Fitz.
Vassar College, Poughkeepsie, New York, U.S.	12.3	A. Clark.
Glasgow, Missouri, U.S.	12.3	A. Clark.
Oxford (University Observatory)	12.2	Grubb.
Paris	12.2	Secretan.
Lick Observatory, Mount Hamilton, California, U.S.	12.0	A. Clark & Sons.
Vienna	12.0	A. Clark & Sons.
Middletown University	12.0	A. Clark.
Mr. White's, Brooklyn, New York, U.S. ...	12.0	A. Clark.
Baron Von Engelhardt's, Dresden, Saxony ...	12.0	Grubb.
The late Mr. J. Watson's, Sunderland	12.0	Cooke.

^x Some account of this, together with an autotype illustration of it, will be found in Lockyer's *Stargazing*, p. 306.

BOOK VIII.

SPECTROSCOPIC ASTRONOMY*.

CHAPTER I.

INTRODUCTORY.

A New Department of Astronomy.—“Celestial Chemistry.”—Outline of the History of the Recognition of the Solar Spectrum.—Explanation of the Dark Lines.—The three Orders of Spectra.—Variations in the width and in the refrangibility of lines.

THE latter half of the 19th century has witnessed the rise and development of an entirely new department of astronomy, a department in which results have already been attained which seemed but a few years ago utterly beyond our reach even to hope for. We could watch the Sun, the planets and the stars, could mark their movements, ascertain to some degree their distances, and estimate their masses, but to be able to do more than guess at the substances of which they were composed seemed a pure impossibility. Yet not only has this problem been solved, not only have we been able to ascertain many of the constituent elements in the Sun or stars, with equal or greater certainty than the chemist in his laboratory can determine those of some body placed in his hands for analysis, but we are even looking to the heavenly bodies for further information as to the more intimate construction of the very elements which we handle here on the earth.

* I owe this Book to the kindness of Mr. E.W.Maunders, F.R.A.S., Assistant in Charge of the Spectroscopic Department of the Royal Observatory, Greenwich.

This "Celestial Chemistry," as it may well be called, depends for its basis upon the examination of the quality of the light received from a luminous body, in other words, of its colour. That this examination should be as complete as possible, the light is made to pass through an instrument which has the power of sifting colour from colour, so that if the light be made up of many different colours these may no longer be confused together but seen separately.

It is to Newton that we owe the proof that sun-light, apparently so simple, is really complex, and compounded of many different colours, or, as he put it, "is a heterogeneous mixture of differently refrangible rays." In a paper on Optics, presented to the Royal Society in 1672, he describes a series of experiments on the subject^b. In one of these, he admitted a beam of light through a round hole into a darkened chamber; and fixing a prism close to the hole, placed a screen of white paper on the other side of the room to receive the rays. Had not the prism been there, the light would have followed a straight course and formed a round white spot on the screen. But instead, the direction of the beam was changed, and it formed on the screen an oblong rainbow-tinted band, equal in width to the diameter of the round white spot, but nearly 5 times as long. This Newton called the Solar Spectrum, and hence the image formed by the light of any luminous body, after it has passed through a prism, is said to be the *spectrum* of that body.

This rainbow-coloured strip consisted of a multitude of overlapping images of the aperture through which the light was admitted; each different coloured light forming its image on its own proper part of the spectrum.

Newton proved that the explanation of this phenomenon lay in the fact that all the colours of which white light is made up are not equally refrangible; violet for instance being bent more out of its course by a prism than green is, and this again more than red. For the sake of convenience, and because it would be impossible to give a distinctive name to all the gradations

^b *Phil. Trans.*, 1675-72, p. 3075.

of colour, 7 only are generally recognised, though recently a necessity for more names seems to have been felt. These 7

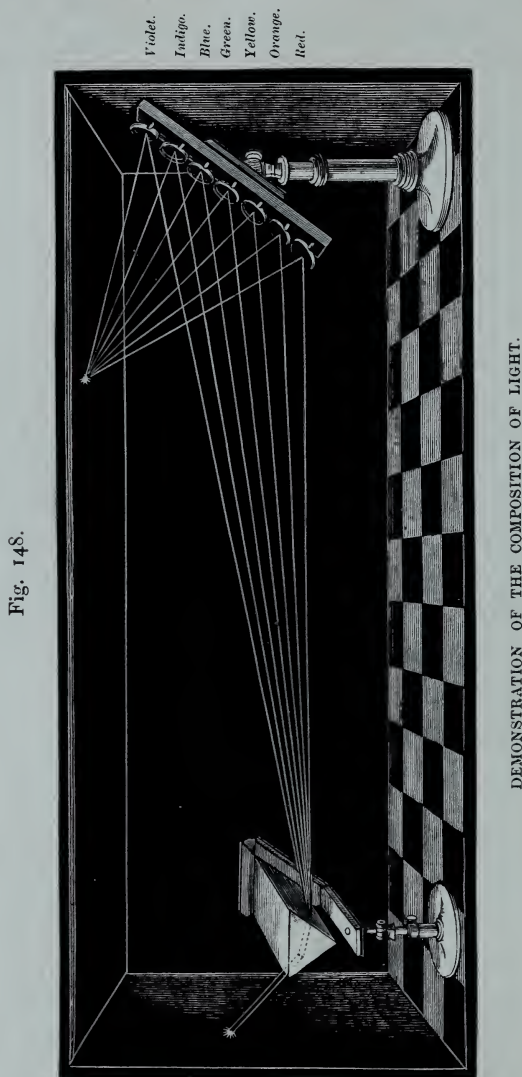

colours are violet, the most refrangible, and, in the order of their refrangibility, indigo, blue, green, yellow, orange and red. None of these can be again divided; so if green light for example be

allowed to pass through another prism, it will still be green, and will not show the slightest approach to violet or red.

Fig. 149.

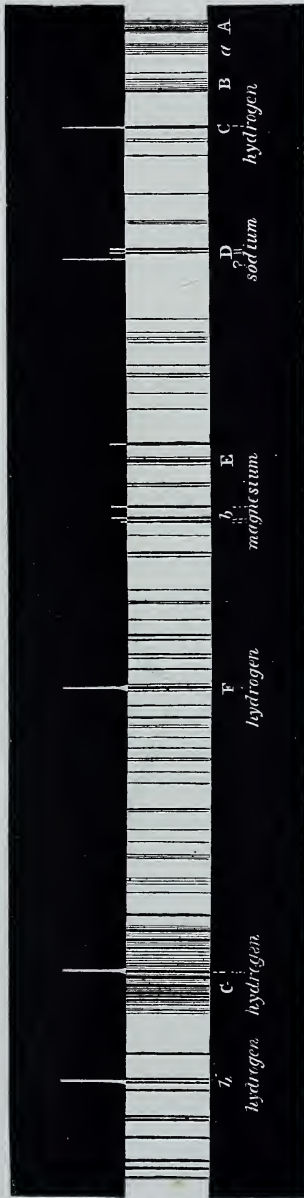

THE SOLAR SPECTRUM.

More than a century later Wollaston was anxious to find out

if there were any distinctly marked limits to the different colours in the solar spectrum. It was evident that in Newton's experiment the colours were not obtained in a state of purity, for even if there were only 7 different colours (and there are many more), the different images of the round hole must have over-lapped, as the entire spectrum was not 5 times as long as any one of them.

Wollaston therefore substituted a narrow slit for the round aperture, and at once perceived 7 gaps or dark lines; so that it became evident that the sun did not send us light of every degree of refrangibility^c.

Wollaston carried his investigations no further, and no advance was made till, in 1814, Fraunhofer, a German optician, took up the same subject with wonderful success. Improving upon Wollaston, who viewed the spectrum directly with the eye, he used a small telescope, and discovered that instead of there being only two dark lines in the spectrum, its entire length was crowded with them. So numerous were they that he counted no fewer than 574 between the red and the violet^d. The darkest of these, ever since called after him the "Fraunhofer Lines," he distinguished by the letters of the alphabet, and as they are continually referred to by these letters, it is important that their positions should be accurately borne in mind. (See Fig. 149.)

Seen with such a dispersive power as that which Fraunhofer used, A is a thick dark line at the extreme red end of the spectrum; B is also a broad line; between the two is a cluster of several lines, called *a*; C is dark and fine; all four of these are in the red. D is a very close pair of dark lines in the orange-yellow; E is the middle and darkest of a group in the yellowish-green; *b* a group of three dark lines where the green is more of an emerald tint; F seems to be about the boundary between green and blue; G is in a crowded cluster in the indigo; and H is a pair of bands near the limit of vision in the extreme violet.

^c *Phil. Trans.*, vol. cxii. p. 378. 1802.

^d *Denkschriften der K. Acad. der Wis-*

enschaften zu München, vol. v. p. 193,

1814-5.

Fraunhofer did not allow his researches to stop here. He proved that the same lines were seen whatever the prism employed, satisfied himself that they were invariable in their position, and determined their wave-lengths.

He further tried varying the source of light, and found that sun-light, whether taken directly or reflected from clouds or Moon or planets, gave the same spectrum.

He examined the light from the stars, and found that their spectra were also crossed by dark lines, but differently arranged in different stars, and in none exactly like those in the solar spectrum.

This precluded the idea that the cause of these lines lay in our own atmosphere, or in general Space, and established the important fact that their origin lay in the Sun and stars themselves.

Fraunhofer did not succeed in getting an artificial light to give a spectrum like that of the Sun, but in examining the light of a candle he remarked a most curious circumstance. It gave a perfectly continuous spectrum crossed by no dark lines, but in the orange, just where the two dark D lines are in the solar spectrum, he saw a pair of bright lines, proved afterwards by Swan^e to be due to the presence of sodium, the one perfectly coincident with one D line, and the other with the other.

In 1859 Kirchhoff, of Heidelberg, being in possession of a spectroscope of very considerable power, resolved to inquire whether this coincidence was perfect. "In order to test," he says, "in the most direct manner possible the frequently asserted fact of the coincidence of the sodium lines with the D lines, I obtained a tolerably bright solar spectrum, and brought a flame coloured by sodium vapour in front of the slit. I then saw the dark lines D change into bright ones. The flame of a Bunsen's lamp threw the bright sodium lines upon the solar spectrum with unexpected brilliancy. In order to find out the extent to which the intensity of the solar spectrum could be increased without impairing the distinctness of the sodium lines, I allowed the full sun-light to shine through the sodium flame, and to my astonish-

^e *Trans. Roy. Soc. Edin.*, vol. xxi. p. 411. 1857.

ment saw that the dark lines D appeared with an extraordinary degree of clearness ^f.”

Finding thus that instead of supplying that lack of light of which the D lines were the evidence, the bright sodium flame only intensified it, Kirchhoff varied the experiment, and instead of sun-light employed the lime-light. “When this light was allowed to pass through a suitable flame coloured with sodium, dark lines were seen in the spectrum in the position of the sodium lines.” Thus, instead of the brilliancy of the continuous spectrum of the lime-light being increased in the yellow by the interposition of the sodium flame, it was actually darkened, and as far as these two lines were concerned he had produced an artificial solar spectrum.

The interpretation of these two experiments supplies us with the principle upon which the application of spectroscopy to astronomy rests. It is thus worded by Sir H. E. Roscoe :—“Every substance which emits *at a given temperature* certain kinds of light must possess the power *at that same temperature* of absorbing the same kinds of light ^g.” So that if the light proceeding from a source yielding a perfectly complete and continuous spectrum has to pass through a sufficient depth of a glowing vapour or gas giving a spectrum of bright lines, those rays of the light corresponding to the bright lines will suffer absorption, for the gas will be opaque to them and only the remaining rays will pass.

It does not follow from this that dark lines will always result in the spectrum. For as the glowing gas is emitting light of the very same quality as that which it absorbs, it can only cause the appearance of a dark line if it absorbs more light of any given refrangibility than it emits. In Kirchhoff’s experiment with the sodium flame and the lime-light, though the two bright lines, which the sodium flame gave when it was viewed by itself, appeared to change into two dark lines when the lime-light was placed behind the sodium flame, the lines did not really diminish in brightness; their seeming blackness, however intense, was

^f *Untersuchungen über das Sonnenspectrum*, p. 9. Berlin, 1862.

^g *Spectrum Analysis*, 2nd ed., p. 215.

only the effect of contrast with the great brilliancy of the background upon which they were seen. On diminishing the brightness of the continuous spectrum from the lime-light, the dark sodium lines would diminish in distinctness until at length they would be entirely lost. If the process were continued further the sodium lines would finally shine out as in a candle-flame, bright on a somewhat less bright continuous spectrum. The absorbing gas must absorb more light of a given wave-length than it emits to cause the appearance of a dark line; if it absorb less, it will evidence its presence by a bright line; if absorption and emission be equal, it will fail to make its presence apparent at all.

From these principles Kirchhoff concluded that the Sun is composed of a highly heated nucleus, whose surface, to which the name of photosphere has been given, yields a perfectly continuous spectrum, and that this is surrounded by less highly heated vapours (sodium vapour being one), the spectra belonging to which give bright lines coincident in position with the Fraunhofer lines. And it necessarily followed that the lines in the spectra of stars must be interpreted in the same manner.

There had been several forecasts of this great discovery. Ten years earlier Foucault had made almost exactly the same experiments with the sodium lines that Kirchhoff had done, but without drawing any conclusions from his observations^h. Professor W. H. Miller of Cambridge had established in 1850 by most careful measurements the perfect coincidence of the lines of sodium with the Fraunhofer lines D; Professor Stokes had given the same explanation of the fact, afterwards given by Kirchhoff; and Sir William Thomson had in consequence taught regularly since 1852 that sodium was a constituent of the sun's atmosphereⁱ. The celebrated Ångström of Upsala in 1853 had independently arrived at very similar conclusions, and almost at the time of Kirchhoff's discoveries Professor Balfour Stewart was engaged in demonstrating this "Theory of Exchanges." Nevertheless it was not until Kirchhoff's labours that spectrum

^h *L'Institut*, Feb. 7, 1849, p. 45.

ⁱ *British Association Report*, 1871, p. xcv.

analysis became actively enlisted in the cause of Astronomy, although the principle he enunciated was already known to certain individual philosophers, and even to a small extent applied.

In the interval between Fraunhofer's discovery of the dark lines in the solar spectrum and Kirchhoff's explanation of them, much progress had been made in spectrum analysis as far as it applied to terrestrial substances, and certain leading principles had been laid down, the which, as they bear equally on astronomical work, must here be briefly referred to.

By the investigations of Fox Talbot, Foucault, Brewster, Draper and others, three kinds of spectra had been defined.

(1.) The spectrum of an incandescent solid or liquid, which is always perfectly continuous, showing neither dark lines nor bright^k. This important law was laid down by J. W. Draper in 1847. (2.) The spectrum of a glowing gas, which consists of bright lines or bands separated by dark spaces, unless it be under great pressure, when, like a solid or liquid, it yields a continuous spectrum. Such lines are characteristic of the element that causes them, and therefore from the position of the bright lines in a spectrum it is possible to tell their origin. (3.) A spectrum crossed by dark lines. This occurs when an incandescent body is viewed through absorbent vapours, and the dark lines are as characteristic of the vapours causing them as the bright lines in the second class of spectra are. If the absorbing vapour itself gives a spectrum of bright lines, it follows from Kirchhoff's principle that the dark lines it causes will exactly correspond to them, and hence be as sure an indication of its presence as the bright lines themselves would be.

The principle, essential to the value of the spectroscope as a means of analysis, either as applied to the heavenly bodies or in the laboratory, that the lines of the spectrum are characteristic of the element which causes them, was by no means readily established; the ubiquity of the two bright lines of sodium, destined, as has just been mentioned, to be so helpful in a later phase of the development of the new science, being a great difficulty at

^k The rare earth Erbium appears to be an exception.

first. For it was long before it was recognised that sodium was to be found almost everywhere, nor was the full delicacy of the spectroscopic test for its presence at all appreciated. So that the fact that substances the most diverse, and which did not appear to have a single element in common, all gave the same familiar pair of orange lines, greatly hindered the progress of spectrum analysis in its earlier days.

The researches of Huggins, Lockyer, and Frankland have shown us how to interpret variations in the width of a line; an increase of pressure causing the lines to widen in both directions¹. A twist, or widening in one direction only, or an entire displacement, is due to another cause, and it enables us to determine the rate at which a luminous body is approaching us or receding from us. The impression of colour made on the eye depends on the interval between the waves of light as they enter it. Thus the shortest waves produce the sensation of violet, and the longest of red. So if a stream of glowing hydrogen is rapidly approaching the observer, a greater number of waves of light from it will enter his eye each second than if the source of light were at rest, and therefore the intervals between the waves, in other words the wave-lengths, would seem to be diminished. So that if he were examining, say the line corresponding to F, it would seem to be more of a violet hue than before. It will therefore be seen displaced in the spectrum in that direction, as compared with the same line given by the hydrogen in a vacuum tube, or with other lines in the sun, the elements occasioning which are at rest. In like manner, if the source of light be receding, the waves of light seem lengthened, and any particular line will seem to be displaced towards the red end of the spectrum.

Spectroscopic astronomy, though so comparatively young, already boasts an extensive and rapidly increasing literature, and has yielded many most important results, the principal of which, together with the methods by which they have been obtained, may now be briefly passed in review.

¹ *Phil. Trans.*, vol. clviii. p. 547. 1868. *Comptes Rendus*, vol. cviii. p. 1236, For some remarkable exceptions see June 17, 1889.

CHAPTER II.

SPECTROSCOPY AS APPLIED TO THE SUN.

Elements recognised in the Sun.—The Telluric lines.—Researches of Janssen and Egoroff.—Cornu's device.—The Rainband.—Spectra of Sun-spots.—Observations at Greenwich, Stonyhurst and South Kensington.—Behaviour of iron lines.—Lockyer's dissociation theory.—Spectra of Faculæ, Pores and Granules.—Spectra of Prominences.—Method for observing them in full sunshine.—Their systematic observation.—Connection with spots and faculæ.—Spectrum of the Chromosphere.—Spectrum of the Corona.—Its threefold character.—Spectrum of the Zodiacal Light.

KIRCHHOFF having explained the presence of two of the solar lines, endeavoured to account for others. Instead of the simple spectrum of sodium, however, he took the most complicated that he had at hand. There are no fewer than 450 lines in the spectrum of iron as he knew it, and he resolved to ascertain if any of these were coincident with any of the solar lines. Placing a small right-angled prism before the upper half of the slit so as to reflect the light from an electric spark passing between electrodes of iron, while sunlight was admitted directly through the lower half, he obtained the two spectra one above the other, rendering comparison easy. To his surprise every one of 60 bright lines in the spectrum of iron had its counterpart in a dark line in the solar spectrum, and not only so, but in general each strong line was represented by a strong line, each faint line by a faint line^a.

This work of comparison was zealously continued by Kirchhoff and Bunsen, and by Ångström of Upsala, and soon some 13 or 14

^a *Untersuchungen über das Sonnenspectrum*, p. 12.

elements were recognised as existing in the solar atmosphere. The following table, given by Ångström, shows the elements which gave bright lines corresponding to solar lines, and the number of coincidences established :—

Hydrogen 4	Manganese 57
Sodium 9	Chromium... .. 18
Barium 11	Cobalt 19
Calcium... .. 75	Nickel 33
Magnesium 4 + (3)?	Zinc 2 (?)
Aluminium 2?	Copper 7
Iron 45°	Titanium 118

The number of coincidences in the case of titanium has since been very largely increased by Ångström's coadjutor, Thalén.

In recent years the number of elements whose presence has been detected by the coincidence of the lines of their spectra with those of the Sun has been greatly increased, chiefly by the researches of Lockyer, who employed photography and not direct eye observation for this investigation. To this observer we owe the identification as solar elements of aluminium, cadmium, cerium, lead, molybdenum, palladium, potassium, strontium, uranium, and vanadium; whilst he considers that the presence of 10 other metals, amongst which are bismuth, lithium, silver and tin, is indicated with a considerable degree of probability. Hutchings and Holden have more recently added platinum to the list. The metals therefore are very fully represented, though gold, mercury, antimony, and arsenic have not yet been recognised.

But the case is very different with the metalloids. The presence of hydrogen is indicated with very great distinctness, but of most of the others no traces have yet been detected. Lockyer has indeed recognised carbon, and Schuster oxygen, but in neither instance is the evidence at all striking or emphatic; whilst for chlorine, bromine or iodine, and the other metalloids no satisfactory coincidences have yet been established. There can be no doubt that this marked difference between the two classes of elements has some significance; but at present we can only record the fact. It must however always be borne in mind

that the absence of dark lines corresponding to the bright lines of any element is no proof that it does not exist in the Sun. For it may be at such a temperature as to emit about as much light as it absorbs, or its vapour may be so heavy as not to rise above the level whence the white light of the sun proceeds, or it may even be in such a condition as to give a continuous spectrum itself; and in none of these cases would it give evidence of its presence; or emitting more light than it absorbed, it might make its presence manifest by *bright* lines instead of dark, and it is by no means uncommon for this to happen in special regions of the solar surface. In 1878, Dr. Henry Draper believed that he was able to prove the existence of oxygen in the Sun from the presence of certain bright lines in the spectrum. Later investigations, however, with more powerful instruments, have shown beyond a doubt that the supposed bright lines were merely intervals in the spectrum in which there were few, if any, marked absorption lines.

Notwithstanding the number of elements already detected in the Sun, and the number of lines thus ascribed to some definite origin, it may almost be said that the riddle of the solar spectrum still remains to be read, so numerous are the lines the origin of which has not yet been traced. The labours of Ångström led to the identification of more than 800 of the solar lines in the visible portion of the spectrum, and later observers have raised the number to about 1000. But there are about 10,000 known lines in this region; so that only 1 line in 10 is yet accounted for. Still the general result of the comparison of the lines of the solar spectrum with those of terrestrial elements may be regarded as justifying Ångström's remark, that "the number already mapped suffices to account for the origin of almost all the more prominent rays in the solar spectrum, and to support the opinion that the substances constituting the chief mass of the Sun are without doubt the same substances as exist on the Earth ^b."

Some, however, of the dark lines seen in the Sun's spectrum

^b *Recherches sur le Spectre Solaire*, p. 36.

are undoubtedly due to the influence of our own atmosphere. Brewster, long before Kirchoff's discovery, had noticed that certain lines, which were dark and strong when the Sun was on the horizon, grew faint or disappeared altogether when it was high in the heavens, and with Dr. Gladstone in 1860 he carefully mapped the solar spectrum with special reference to these atmospheric bands^c. Ångström and Secchi also paid great attention to the same subject, but no one more than Janssen, who remained in 1864 for a week on the summit of the Faulhorn in Switzerland, at a height of 9000^{ft} above the sea, and there found the lines due to atmospheric influence much fainter than in the plains. He also from thence examined the spectrum of the light from a large fire of pine-wood, which he caused to be made at Geneva, 13 miles from his place of observation. When viewed near at hand the fire presented a continuous spectrum with no lines, but at the above distance there appeared several of the dark lines which are seen at sunset.

Again, at Paris in 1866 Janssen conducted an even more instructive experiment, which proved aqueous vapour to be the source of many of these *telluric* bands as they are called. The light from 16 gas-burners was caused to pass through a thickness of 118^{ft} of steam, preserved from condensation by special contrivances. The spectrum of this light in the air was entirely free from absorption lines, but, through the steam, groups of lines coincident with some of those in the spectrum of the setting Sun were at once observed^d.

Quite recently this veteran observer has crowned his former labours by an expedition to Mont Blanc in October 1888, his purpose being to ascertain whether certain bands due to the absorption of oxygen were partly solar or wholly telluric. The result of his inquiry was to show that the bands in question were much feebler as seen at that height; indeed most of them actually disappeared when the Sun was on the meridian. More recently still he has confirmed these results by observations of an electric

^c *Phil. Trans.*, vol. cl. p. 149. 1860. 30, 1865; vol. lxxiii. p. 289, Aug. 13,

^d *Comptes Rendus*, vol. lx. p. 213, Jan. 1866; vol. cviii. p. 1035, May 20, 1889.

light on the Eiffel Tower as seen from Meudon Observatory. The A and B groups were distinctly visible with several of the groups due to aqueous vapour.

Another earnest worker in the same field has been Egoroff, who in the intense cold of the winter of 1880-81 observed from Oranienbaum the spectrum of an electric light placed at Cronstadt, 5 miles away across the Gulf of Finland^e. The absorption bands seen under these circumstances would be clearly those of dry air. Egoroff therefore supplemented these observations by an examination of the spectrum of an electric light, the rays from which had traversed a layer of aqueous vapour 59^{ft} in thickness. Similar experiments were made with respect to the absorption of oxygen; repeated observations on the spectrum of the electric light as seen from various distances served to establish, after several years of very patient research, that the great groups A, B and *a* of the solar spectrum are due to the absorption of oxygen; that band δ probably forms a 4th group of the same series; but that group *a* is fundamental for aqueous vapour^f. That A, B, and *a* are telluric, and not principally or partly solar groups, was established by Janssen in his expedition to Mont Blanc alluded to above; and the same observer has brought to light the curious circumstance that oxygen gives a twofold absorption spectrum, the one of fine lines, the other of shaded bands which are only resolved with great difficulty. The bands are not readily seen at low pressures, but at high pressures they are developed at once, for Janssen has found that they increase in distinctness, not in the simple ratio of the density of the gas, but more nearly as its square^g.

A plan has been devised independently by Hastings and by Thollon for distinguishing between true solar lines and those due to the absorption of the earth's atmosphere, without the tedious comparison of the spectrum of a low with that of a high Sun. In consequence of the rotation of the Sun on its axis the East

^e *Comptes Rendus*, vol. xciii. p. 385, Aug. 27, 1883.

Aug. 22, 1881.

^g *Comptes Rendus*, vol. cii. p. 1383,

^f *Comptes Rendus*, vol. xcvii. p. 556, June 15, 1886.

limb is continually approaching us, whilst the West limb is always receding. The waves of light from the East limb are therefore as it were somewhat crowded together, the lines in its spectrum have their wave-lengths a little shortened, and there is a slight displacement towards the violet. The lines in the spectrum of the West limb are similarly displaced towards the red. By a suitable series of comparison prisms, the image of the East limb is thrown on one half of the slit and of the West on the other, and it is at once perceived that the majority of the lines in the one spectrum are shifted with regard to the same lines in the other. But some still remain coincident in the two spectra. These are the lines due to the Earth's atmosphere, for as the atmosphere remains at rest with regard to the observer, the lines due to it occupy the same place in the spectrum, whatever be the part of the Sun towards which the observer is looking. Thus a clear distinction is at once established between the telluric lines coincident in the two spectra, and the solar lines which suffer displacement.

Cornu has improved upon this arrangement in a most ingenious fashion. He gives an oscillating motion to the object-glass which forms the image of the Sun on the slit-plate of the spectroscope, and brings first one limb and then the other on to the slit. The solar lines therefore seem to swing to and fro, whilst the telluric lines remain stationary, and the one class is easily separated from the other. The application of this method to the group *a* at once established its affinity to A and B. The solar lines being easily detected, the remaining lines formed "two unequal series of double lines, whose channelled appearance immediately recalled that of the telluric groups A and B;" indeed, as Janssen showed later, all are alike due to the absorption of oxygen.

Those telluric bands which are due to the influence of aqueous vapour serve an important purpose, being used by many meteorologists as indicators of rain. The spectroscope has this great advantage over the wet-and-dry-bulb thermometer, that whilst the latter can only testify as to the state of saturation of the air

in its immediate neighbourhood, the former records the amount of aqueous vapour in the entire depth of the atmosphere in any

Fig. 150

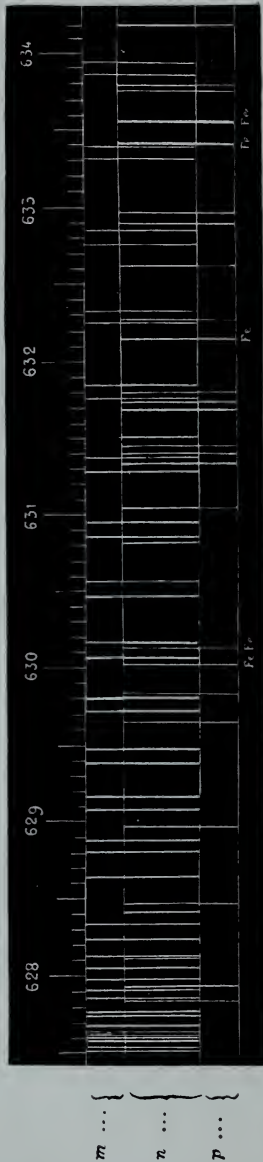

TELLURIC GROUP α (ÅNGSTRÖM).

The scale is double that of Ångström's Atlas.

Description.

m The lines of the complete spectrum prolonged upwards; absorption lines of dry air, the Sun being a few degrees above the horizon.

n Complete spectrum.

p The lines of the complete spectrum prolonged downwards; lines of solar origin.

* The lines attributed to aqueous vapour are those which are not prolonged in either direction.

direction in which it may be turned. By its means therefore the observer is often able to note the formation of aqueous

vapour in the upper strata of the air, before the hygrometer at his side has furnished any indications of a change.

The first person to call general attention to the possibility of using the spectroscope in weather predictions was Piazzi Smyth^h, late Astronomer Royal for Scotland, who gave the name of "Rain-band" to two lines or rather clusters of lines immediately below D towards the red. With a high Sun and on a warm dry day the D lines stand out clear dark and distinct, but with a great formation of aqueous vapour the group changes its appearance altogether. A great number of lines appear, between the two D lines and below them; so many and so dark are they that with a low dispersion they appear to form a broad dark diffused band. Above D towards the blue there is a clear space, and then follows a very broad dark shaded band, the "dry-air" band, always seen at sundown, and generally known by the Greek letter " δ " given to it by Brewster.

Observations of the rain-band have been actively taken up by Klein, Cory, Capron and others, who have found the weather indications it supplies very useful and trustworthy. Considerable practice and care are, however, necessary in order to secure satisfactory results. A perfect acquaintance with the normal appearance of the spectrum can only be obtained by diligent study; the difference between real changes in the intensity of the aqueous bands and changes which are merely apparent (being due only to a change in brightness of the sun or cloud from which the spectrum is taken) must be fully distinguished; and the spectroscope must be used at a constant inclination so that the length of the stratum of air examined may remain the same. Practice too is required before the depth of shade in the rain-band can be correctly estimated on any systematic scale. Capron recognised, and perhaps most observers recognise, 5 degrees of intensity in the rain-band; a faint rain-band being considered of intensity 1; a very strong one of intensity 5; but Piazzi Smyth has used a scale of 10 intensities and Cory one of 20.

^h *Nature*, vol. xii. p. 232. July 22, 1875.

Abney and Festing have extended the field of meteorological spectroscopy by their photographs of the red and infra-red regions. They find that the amount of water in the air can be accurately predicted by the appearance of this portion of the spectrum; one band in particular, below *a* towards the extreme red, a band of the absorption of water, not of aqueous vapour, always becoming more intense before the fall of rain.

Besides the examination of the spectrum of the Sun as a whole, there has also been carried on the examination of the spectra given by various points of its surface or its surroundings, and these have proved of the highest interest and importance. For this department of work a fairly large image of the Sun is needed, and therefore a telescope of somewhat long focus is required to throw an image of the Sun upon the slit. When simply the general spectrum of the Sun's surface is to be examined, it is often sufficient to point the spectroscope towards the Sun without attaching it to any telescope at all, or it may even be turned towards a bright cloud or the sky. So used, the spectroscope is often spoken of as an integrating spectroscope; but when a definite image of the source of light is formed upon the slit, so that the special features of the spectrum of any particular portion of the light can be distinguished, it is said to be an analyzing spectroscope; the spectroscope remaining the same in the two cases, but the mode of its employment being altered.

The first details of the solar surface to be separately examined were the spots. The general appearance presented by the spectra of the different parts of a spot is shown in Fig. 151. The left-hand figure shows the position of the slit on the spot. The centre one shows the portion of the spot covered by the slit, which is what an observer looking directly at the Sun through the slit would see. The portions *AB*, *EF*, at either end of the slit, belong to the clear surface of the Sun, the middle part *CD* to the umbra of the spot, and the parts between *BC* and *DE* to the penumbra. Corresponding to these 5 parts we have 5 narrow spectra, the centre one that of the umbra, on each side of it a spectrum of the penumbra, and outside these an ordinary solar spectrum.

In spite of their darkness as compared with the general surface spots give a perfect solar spectrum, only much fainter than that given by the rest of the disc, showing an increase of *general*

Fig. 151.

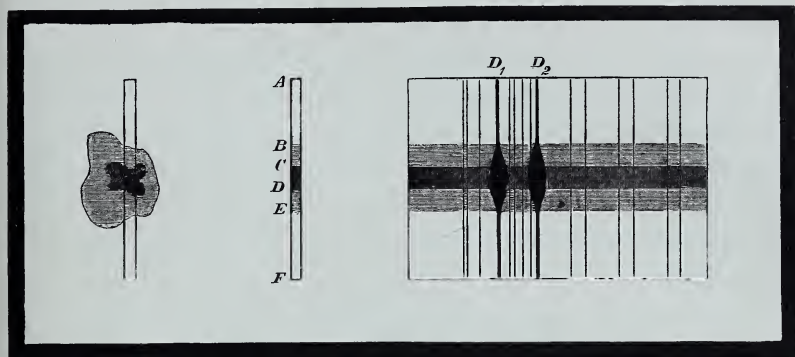

SUN-SPOT AND PART OF ITS SPECTRUM NEAR THE *D* LINES.

absorption. But this is not all. Individual lines are frequently seen to be much widened, and very many of those lines that usually appear fine and faint become much broader and darker. The lines due to sodium, iron, and magnesium are generally affected, but those of titanium, barium, and calcium especially so.

The following table of the changes observed by Maunder in the spectrum of the fine spot of October, 1877, may serve as an example of the phenomena afforded by many of the larger spots¹ :—

Element.	Number of Lines observed.	Character of change.
Calcium... ..	12	Very much darker and about doubled in breadth.
Sodium	2	Very much darker. The two <i>D</i> lines almost meet over the nucleus.
Titanium	11	Very much darker and almost doubled in breadth.
Iron	30	Slightly broader by about one-tenth and decidedly darker, perhaps by one-half.
Barium	4	Almost twice as dark and twice as broad.
Magnesium	4	Much broader and darker.
Nickel... ..	6	Broader by one-half, slightly darker.
Chromium	3	Somewhat darker and broader by about one-tenth.
Hydrogen	3	Much fainter and less distinct. <i>F</i> line reversed in the neighbourhood of the spot, due North of the centre, on November 5.
Coronal line ...	1	Much fainter over the spot.
<i>D</i> ₃	1	Not seen either bright or dark in spot or bridge.
Telluric bands	1	Band <i>a</i> broader and darker.

¹ *Greenwich Spectroscopic Observations*, 1877, p. 87.

Another remarkable feature is that it is by no means uncommon to find *bright* lines in the spectrum of a spot; sometimes even a line is seen both dark and bright at the same time, the dark part being bent to the red, the bright to the violet; thus showing that there was a down-rush of cooler gas from the surface, and a corresponding ejection of the more highly heated gases of the interior. Lockyer in particular has recorded such phenomena. The same observer has frequently noticed the most singular and fantastic twistings and bendings in particular lines over a sun-spot, especially in F, due to hydrogen, showing movements and variations of pressure of the most complicated character.

Fig. 152.

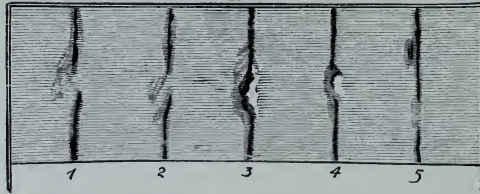

CONTORTIONS OF F LINE ON DISC OF SUN.

Nos. 1 and 2, rapid down-rush and increasing temperature; 3 and 4, up-rush of bright hydrogen and down-rush of cool hydrogen; 5, local down-rushes associated with hydrogen at rest.

A curious phenomenon, well known in laboratory experiments, namely the appearance of a bright line in the centre of a greatly broadened dark line, has also been witnessed in spot spectra. The great spot of November, 1882, was signalled in this manner. Maunder, who observed its spectrum at Greenwich on Nov. 18, 20 and 21, records that " D_1 and D_2 were not only reversed but extravagantly broadened, each line forming a very broad and ill-defined dark band, quite six tenth-metres in breadth,"—*i.e.* the two lines were expanded so as to touch each other at their widest part,—“with a sharp, narrow, bright line in the centre, apparently at the normal place of the line. This appearance and the reversal of D_3 were noticed whenever the definition and light were a little better than usual.” Young noticed the same curious appearance in the D lines in the spectrum of a spot

observed on Sept. 22, 1870^k. In this case the D_3 line, which is not ordinarily visible in the solar spectrum either as a bright or dark line, was "quite conspicuous as a dark shade." The magnesium lines behaved on this occasion in the same manner as the sodium lines. A similar change was suspected in several of the principal iron lines near F in the spectrum of the great spot of November, 1882. The same spot showed a very remarkable reversal of the F line of hydrogen. On Nov. 18, C and F were exceedingly bright, although the day was misty and cloudy. On Nov. 20, "a remarkable reversion of the F line was noticed. At the preceding edge of the great nucleus there was a broad bright flame, which touching the F line at the extreme preceding edge of the nucleus, sloped away from the nucleus in the preceding direction, and from the F line towards the blue. It was inclined to the F line at an angle of about 40° , was 1, or perhaps $1\frac{1}{2}$ tenth-metre in average breadth, and extended to a distance from the F line of 3 or perhaps $3\frac{1}{2}$ tenth-metres. It was pointed at each end, and was nearly but not quite straight, being a little twisted near its centre. A displacement of $3\frac{1}{2}$ tenth-metres towards the blue would correspond to a motion of approach^l of 134 miles per second." On Nov. 21, the Sun was in yellow fog whilst its spectrum was under examination, but "a momentary gleam of clearer sunlight showed F reversed in the most intricate and beautiful manner right across the great nucleus, not over its entire area, but at short intervals from one side to the other, even over its blackest portion. These stars of brilliant blue light were on the average about twice as broad as the dark F line on the general disk, sometimes four times as broad, and were but little, if at all, displaced."

Young has witnessed the reversal of lines in a spot spectrum on a yet greater scale. On Sept. 28, 1870, he was examining the spectrum of a large spot, and saw all the lines of hydrogen, magnesium and sodium reversed, besides some others. "The hydrogen lines suddenly grew greatly brighter, and on opening

^k *The Sun*, by C. A. Young, 2nd ed., 1882, p. 130.

^l That is to say, an up-rush.

the slit two immense luminous clouds were made out, one of them nearly 130,000 miles in length, by some 20,000 miles in width; the other about half as long. They seemed to issue at one extremity from two points near the edge of the penumbra of the spot^m."

The general result of these and similar observations of spot spectra has been to show that the spots are regions in which the general absorption is much increased, and that many vapours and gases, particularly iron, titanium, calcium and sodium, are at a much greater pressure there than at the general surface. The inference, or at all events the suggestion, is that with a breach in or a sinking of the photosphere we have the constituents of the outer cooler atmosphere pouring down to fill the depression, a movement compensated by, if not caused, by uprushes of the glowing gases, in particular of hydrogen, from the strata below.

But the observations of spot spectra in more recent years have brought many other facts to light than these, some of which are most intimately connected with the views which we have to form of the general structure of the Sun as a whole. First, besides the general absorption, shown by the darkening of the spectrum as a whole, and the special selective absorption shown by the widening of particular lines, there is sometimes a darkening of particular regions of the spectrum. Thus Maunder notes of the November spot, 1882:—"The general absorption was not however uniform; here and there, there were broad ill-defined patches, noticeably darker than the rest of the spectrum. The district lying between λ 4900 and λ 4830 was one of the most marked of these." Perry at Stonyhurst has recorded a similar phenomenon.

Young has gone further still and has resolved the general shade of the spectrum of the nucleus of a spot into an immense number of fine lines. "In certain regions," he writes, "the spectrum of the spot-nucleus, instead of appearing as a mere continuous shade, crossed here and there by markings dark and light, is resolved into a countless number of lines, exceedingly fine and closely packed, interrupted frequently between E and F (and

^m *The Sun*, p. 131.

occasionally below E) by lines as bright as the spectrum outside the spotⁿ." This observation shows that the increased absorption over the spot was due to substances in the gaseous state, and not to solid particles.

Then the appearance of shaded bands in spot spectra is not uncommon. Thus Young in examining a spot spectrum on one occasion noticed between C and D some shaded bands, terminated abruptly at the end nearer the red by a hard dark line, but fading out gradually towards the violet at a distance of 3 or 4 divisions of Kirchoff's scale. These, he suggests, may indicate the formation of compound bodies, in consequence of a lowering of temperature; the solar heat usually causing the dissociation of the elements composing them.

A number of bands of a somewhat different character were discovered by Maunder in the spectrum of a fine spot seen on Nov. 27, 1880. These bands, which were usually about a tenth-metre in breadth and shaded at both edges, extended in a pretty continuous series from a little above the δ lines of magnesium, about half-way towards F. It has been suggested by Liveing and Dewar that some of these bands are due to cerium. The most important fact about them, however, appears to be that their existence was not recognised in 1879 or the earlier months of 1880; that in 1881 they formed a characteristic feature of most of the larger spots, but in 1883 they were less frequently seen, and if seen were less distinct. On some occasions they appeared to be resolvable into clusters of fine lines.

A similar discovery was made a little later in another part of the spectrum by Perry and Cortie at Stonyhurst, who brought to light a series of bands in the red. In this case however the very important fact was established that the bands corresponded with lines seen in the chromosphere. It should be noted that usually nothing corresponding to either series of bands can be detected in the spectrum of the general disk, though sometimes they have been traced not only over a spot but to some little distance from it.

ⁿ *Phil. Mag.*, 5th Ser., vol. xvi. p. 461. Dec. 1883.

But the most important work on spot spectra in recent years has been that carried on by Lockyer at South Kensington,

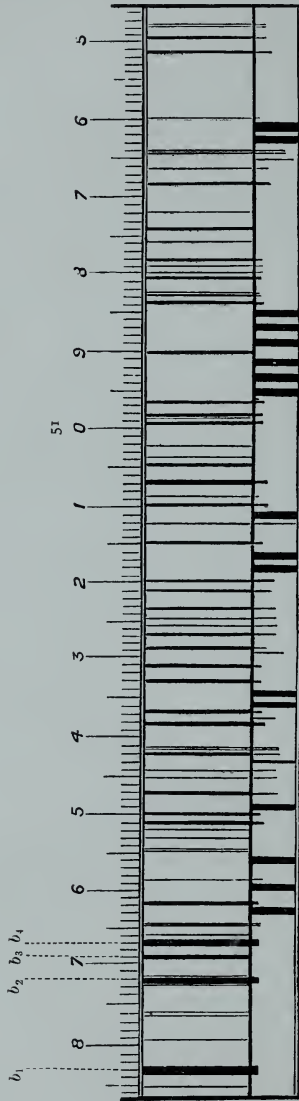

Fig. 153.

PART OF THE SPECTRUM OF A SUN-SPOT, OBSERVED AT GREENWICH, NOV. 27 AND 30, 1880.

The figure represents a portion of Ångström's map of the solar spectrum near b , with the spectrum of the Sun-spot below, showing the new dark bands observed in it. In the case of the other lines the length represents the amount by which the line was broadened over the spot—full-length corresponding to a line which was doubled in breadth; half-length to one of which the breadth was increased by one-half; and so on.

and which has taken the form of the very detailed watching of certain regions of the spectra, and the recording of the most

widened lines in every available spot. This work has brought into view the fact that the characters of spot spectra not only differ one from another, but that they differ at different periods of the Sun-spot cycle. The practice has been to note the 6 lines in each of the regions F to *b* and *b* to D which had undergone the greatest increase in breadth, not which were absolutely the widest, and the result of the observation of 700 spots extending over 6 years has been to show that:—“(1) The most widened lines in Sun-spots change with the Sun-spot period. (2) At and slightly after the minimum, the lines are chiefly known lines of the various metals. (3) At and slightly after the maximum, the lines are chiefly of unknown origin.”

In the detailed examination of individual lines in spot spectra it has been seen,—and more particularly with regard to the lines due to iron,—that different lines belonging to the same element do not by any means always behave in the same manner. It is not by any means *all* the lines of iron that are manifestly widened over a spot; should there be cases of reversal,—lines being seen bright instead of dark,—these will not be characteristic of the entire series, but only of some individuals; and if there be displacements or bendings indicating motion up or down in the solar atmosphere, some of the iron lines will display these changes, but others will remain at rest, or perhaps even show a shift in the opposite direction; as if the vapour of iron were at once at rest, and in rapid motion in two different directions at the same time.

This curious and unexpected fact has been explained by Lockyer in the following manner. He has noted that even with such a comparatively small range of temperature as we can obtain in our laboratories, the spectrum of a given element may be made to assume very different appearances. At a low temperature it will show a certain line or lines; as the temperature is raised other lines will appear; with a greater increase of temperature still, yet other lines will appear, and the lines first seen may become fainter; with a further increase other

° *Chemistry of the Sun*, p. 324.

changes may occur, until at length a spectrum wholly unlike that first seen may result. In the spectrum of calcium, for example, Lockyer records the changes produced in its appearance by change of temperature as follows^p:—“(1) At a low temperature a spectrum which contains no lines in the blue; (2) when we increase that temperature,—the temperature of a Bunsen burner is sometimes sufficient,—we get a line in the blue at wave-length 4226.3; (3) when we pass from a Bunsen burner to an electric lamp we get this blue line intensified, and at the same time we get two new lines in the violet, named H and K, at wave-lengths 3933 and 3968; (4) using a still higher temperature in the arc, we thin the blue line, and at the expense of that line, so to speak, we thicken the two in the violet, so that the latter equal the blue line in thickness and intensity; (5) passing to a large induction coil with a small jar we make the violet lines very much more prominent; (6) and using a larger induction coil and the largest jar we can get we practically abolish the blue line and get the violet lines. Note that we have simply produced these effects by varying the temperature.”

These changes are all that we can effect by the means at our command in our laboratories, but the temperatures of the Sun or stars are doubtless far higher than any we can produce artificially, and accordingly we have evidence of a yet further change in the calcium spectrum. The Sun shows us the line in the blue as a thin line, and the violet lines H and K as very broad. In the prominences we have only H and K; but in the spectra of some stars we have H by itself; in those of others H is broad and K thin; in others again both are broad; and in the spectrum of Arcturus K is broader than H.

Many spectroscopists explain these changes by ascribing them to the different modes in which the molecules of the element vibrate under different conditions of temperature, but Lockyer has framed a much more elaborate theory, and regards these changes of appearance as indicating a breaking up of the sub-

^p *Chemistry of the Sun*, p. 241.

stances into simpler and more strictly elemental bodies⁹. This theory is based upon the circumstance that the spectrum of a compound body when it is heated so as to produce dissociation shows changes of just this character. Lockyer also places much stress on the fact, early noticed in the development of spectrum analysis, that many lines appeared to be common to the spectra of two or more elements. At one time these common lines were supposed to be due to the presence of impurities in the metals under study, but further research showed this idea to be untenable in many instances. Lockyer prefers to consider them as "basic" lines, lines of more truly elemental substances; but his theory has been severely shaken by the discovery, as spectroscopes have improved in power, that most if not all of these "basic" lines have been resolved into two or more components, and even in many cases, referred the one to one element, the other to the other. Previously to this discovery Lockyer's position was a strong one, for these "basic" lines were precisely those most frequently affected, in what he considers the hotter regions of the Sun, namely, the spots and the prominences; as on his theory they should have been. But the resolution of these lines under superior dispersion suggests that the cause of their appearing to be more frequently affected was perhaps simply an optical one; a slight increase in breadth, or darkness, or a feeble reversal of the line, being more easily detected when it took place in both components of a very close and unresolved double than when it took place in a single line. A table given by Lockyer as a striking proof of his theory will illustrate this point. Taking a certain district of the spectrum, 345 lines due to the 12 principal solar elements were observed in it. Of these, 183 were unaffected over spots or in prominences, 54 were seen in prominences but not over spots, 40 over spots but not in prominences, and 68 in both. If we take the iron lines alone, then the numbers were:—total 104; unaffected 25, prominence storms alone 29, spots

⁹ Or at least as indicating a simpler molecular condition. Lockyer's theory does not necessarily imply that our so-called elements result from the combina-

tion of two or more distinct simpler substances; they may merely result from a more complex condition of the molecules of the same substance.

alone 17, seen in both 33. This remarkable diversity in behaviour, Lockyer forcibly pointed out, could be readily understood if we were dealing with 4 different substances, but seemed scarcely reconcilable with the idea of iron being a true element. Lockyer's argument was at that time strengthened by the fact that of the 345 lines 18 were common to two metals, and all the 18 were widened over the spots, and 13 of the 18 were seen in prominence storms. Regarded as truly single lines, due to two elements, this fact was most striking; but when they are looked upon as very close doubles, it seems at least possible that the reason they are so much more frequently seen in spots and prominences is simply due to the fact that a slight change occurring in each component of such a pair is more readily seen than it would have been in each of two widely separated lines. At the same time there is an alternative view, and it is one which Lockyer advocates, namely that a given "basic" line seen in one combination may show a slight displacement or shift from its position as seen in another combination, a suggestion quite analogous to known facts.

It has already been pointed out that the lines most affected in Sun-spots differ at different periods of the spot cycle. This Lockyer explains on his view by maintaining that the Sun is hotter at maximum, and that therefore the spot spectra are then richer in lines unknown to us in our terrestrial experiments than at any other time. Reviewing his theory as a whole, it must be said that he has followed it up with great patience and skill, and has brought an immense amount of fresh information to light on solar physics, but at the same time he has convinced very few of the truth of his dissociation hypothesis, at least in its cruder form of involving that our so-called elements are really compound bodies. The idea that they may exist in the Sun in a somewhat simpler molecular condition might meet with more favour; but for the most part spectroscopists have been content to accept the fact of the variations of spectra consequent on changes of temperature merely as evidence of a changed method of vibration of the molecules without assuming that the molecules themselves have undergone disintegration.

The great extent and high value of the observations and experiments effected by Lockyer during the evolution of his theory have made it necessary to accord it a space which when compared with the limits necessarily assigned to this section must be accounted very large; but it was impossible to refuse it notice, and as it is many important issues have been left out.

Passing from the spots, the next most important features of the solar surface are the faculæ. These give an ordinary solar spectrum but with diminished absorption, both general and particular; the whole spectrum being brighter than that of the general surface, and individual lines being often missing. This would seem to show that they are elevations above the ordinary surface, and hence are seen through a smaller depth of atmosphere. Under very special circumstances the spectra of the pores and granules of the solar surface have been observed; the former resembling minute spot spectra in character, the latter approximating to those of the faculæ. Thus in 1880 Thollon and Trépiéd spent five weeks at the meteorological observatory on the summit of the Pic du Midi, and in the clear and steady air of the early mornings obtained the most wonderful definition of the spectrum, lines corresponding to the granulations of the solar surface and running the length of the spectrum being seen under favourable circumstances; and it was specially remarked that the C and F lines seemed to be composed of distinct dark and bright fragments corresponding to the pores and granules respectively^r.

Some few years before Kirchoff's discovery total eclipses of the Sun had revealed to astronomers the fact that the Sun was surrounded by appendages of the strangest character. First, by a shallow rose-coloured envelope from which sprang fantastic-looking prominences of the same colour; then by a halo of silver-white light known as the corona; and beyond this by some fainter radiations of it extending in some cases more than 1° from the Sun's surface.

The origin and nature of these appearances were involved in mystery, and, until the spectroscope was called into action, there

^r *Comptes Rendus*, vol. xcvii. p. 834. Oct. 15, 1883.

seemed no likelihood of explaining them. In the eclipse of 1868, at the suggestion of Tennant, the spectroscope was added to the weapons of research, and it at once revealed to Janssen that the prominences give a spectrum of bright lines, and therefore consist of glowing gas^s. Struck with the exceeding brilliancy of two of the prominences he resolved to endeavour to see the lines when the Sun was no longer eclipsed, and putting his project into execution on the morrow met with complete success.

The principle by which it was effected is briefly this. The hindrance to seeing the prominence lines at all times is due to the overpowering light which our atmosphere reflects from the Sun. But the spectrum of this light being simply that of reflected Sun-light can be weakened to any required degree by increasing the dispersive power and so lengthening out the spectrum; while that of the prominences, consisting mainly of 3 bright lines, suffers very little diminution of intensity in each line by the increase of the dispersion; its principal effect being simply to increase the distance between them.

Lockyer had suggested, almost two years earlier, that the spectroscope might be used for seeing the prominences, but lack of instrumental power prevented him from succeeding, until shortly after Janssen's discovery^t. Not, indeed, that his spectroscope could not have shown him the prominence-spectrum, which may be readily seen even with feeble dispersion, now that we know just where and what to look for and how to look for it. But it always requires a much more powerful instrument to make a discovery than to repeat the observation when it has been made.

Huggins and Stone had both endeavoured in the same manner to see the prominence-spectrum, but failed, from the same cause that so long hindered Lockyer, namely insufficient dispersive power.

The ordinary prominence-spectrum consists of the 4 lines of hydrogen, of which the 2 violet lines are usually too faint to be usefully dealt with, and a fifth line, in the yellow, close by the D lines and known as D_3 .

^s *Annuaire du Bureau des Longitudes*, 1869, p. 584.

^t *Solar Physics*, p. 570.

This yellow line is not found in the spectrum of any known element, nor is any corresponding dark line usually seen in the solar spectrum. Secchi indeed stated that he had seen it bright

Fig. 154.



SPECTRUM OF THE SUN NEAR LINE C WITH THE SLIT RADIAL.

on the Sun's disc, and Trouvelot claims to be able to see it under ordinary conditions as an exceedingly fine dark line.

Fig. 155.



SPECTRUM OF THE SUN WITH SLIT TANGENTIAL, SHOWING LINE C REVERSED ON THE CHROMOSPHERE.

The same lines, but shorter than in the prominences, are found all round the Sun and are given by the rose-coloured envelope noticed in eclipses, from which the prominences rise. This stratum has been named the chromosphere.

The lines of other elements frequently appear in the spectrum of the chromosphere or prominences, but they do not attain to nearly the same height that the hydrogen lines do. Sodium, magnesium, and iron are often to be seen, and on one occasion Lockyer saw *hundreds* of the Fraunhofer lines reversed, that is, bright on a dark background, at the foot of a prominence". Occasionally however these heavier metals are flung out to much greater heights, and the same observer once saw a cloud of magnesium vapour floating over a prominence.

The bright lines of hydrogen generally taper towards a point, the greater their distance from the limb. This is particularly

Fig. 156.

SLIT PLACED RADIALLY
TO VIEW A PROMINENCE.

Fig. 157.

SLIT PLACED TANGENTIALLY
TO VIEW A PROMINENCE.

the case with the $H\beta$ line, the "arrow-headed" appearance of which close to the edge of the disc has often been remarked by Lockyer, Young and others; and plainly indicates that the pressure rapidly diminishes from the limb outwards. The metallic lines also appear thinner when seen bright in the chromosphere than when seen dark on the Sun. In order to see the spectrum of the chromosphere, the spectroscope may be placed in one of two positions, either with the slit perpendicular to the image of the Sun's limb, or else tangential to it. In the former case the spectrum obtained will show above the solar spectrum a number of bright lines of varying lengths. In the latter case, the faint solar spectrum reflected from the air occupies the whole

^u *Solar Physics*, p. 521.

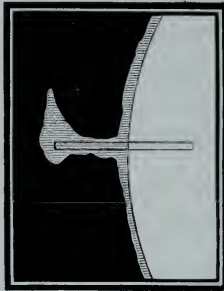
breadth of the field, but is crossed by three principal bright curved lines in place of the dark ones C, D₃ and F. The spectrum near C as seen with a radial slit is shown in Fig. 156, and with a tangential slit in Fig. 157.

Huggins soon showed that it was possible by using a greater dispersion to open the slit wide enough to see the prominence itself. The atmospheric spectrum then becomes very impure, so that the Fraunhofer lines disappear. The image of the Sun is carefully kept close to, but outside the slit, or else its great

Fig. 158.

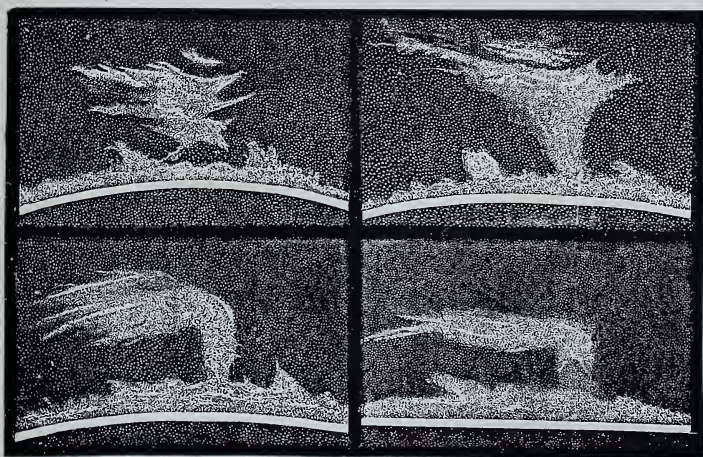

CHANGES IN PROMINENCES NOTICED BY YOUNG.

brilliancy would to some extent dazzle the eye and prevent the observer seeing the details of the prominences under inspection.

Lockyer, Zöllner and others, at once made use of this improvement, and the very first observations of Zöllner induced him to divide them into two classes, clouds and jets. The more recent classification deals with their composition and behaviour rather than with their shape, and now the great distinction drawn is one between the quiet *prominences*, showing only D₃ and the hydrogen lines, and the violent, short-lived, *metallic eruptions* showing many of the lines of the metals as well as those of hydrogen. Both classes are in a constant state of change, but in the case of the

hydrogen prominences, the changes are usually gentle and gradual, whilst with the metallic eruptions they are as generally rapid and violent. Some of the storms which have been witnessed bear testimony to forces of the most marvellous intensity. Thus Young on September 7, 1871 saw a prominence, 100,000 miles long, by 54,000 miles high, after the most rapid and wonderful changes, vanish altogether in about two hours. In 10 minutes parts of the prominence had risen fully 100,000 miles, the greater portion of it having been "literally blown to shreds^v." The accompanying sketches (Fig. 158) of the changes in another prominence noticed by the same observer are interesting from the indications which they afford of violent side winds as well as of eruptive force.

Evidence of motion is supplied also by the bending of the prominence lines; indeed their displacement is often much more

Fig. 159.

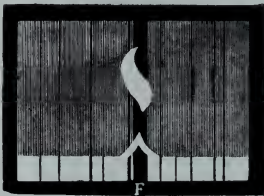

BENDING OF THE LINE $H\beta$ IN
THE SPECTRUM OF A
PROMINENCE.

marked than that of the lines of spots. According to Lockyer, the motion, as thus evidenced, of the gas streams is frequently 40 miles per second for vertical movements; and in cyclonic or horizontal movements as great as 120^x . In a storm watched by Maunder on May 13, 1882 a prominence was observed to travel away from the Sun, and down the spectrum towards the extreme red with a rapidity amounting to 325 miles

of recession in the line of sight—horizontal motion as it regards the Sun—and of 68 miles per second away from the Sun^v.

At the present time of minimum solar activity (1889) these great storms have quite ceased, and the solar atmosphere is usually in a state of complete calm.

Respighi, adopting Huggins's improvement, commenced an entirely new department of solar observation, closely corresponding in its nature to that of Schwabe and Carrington with

^v *Boston Journal of Chemistry*, vol. vi. p. 49. Nov. 1871.

^x *Solar Physics*, p. 493.

^y *Greenwich Spectroscopic Observations*, 1882, p. 7.

regard to Sun-spots; namely the daily measurement and delineation of all the prominences visible round the Sun's disc, a work which he carried on from Oct. 26, 1869 to April 30, 1872, with an interruption of about 6 months in 1871. This gap is fortunately covered by the similar observations of Secchi, and the series has been continued by Tacchini and Ricco down to the present time. These observers arrange their sketches of the prominences on any day in a straight line, which is marked off into divisions corresponding to degrees of the Sun's circumference, so that a glance at a series of these maps shows in what parts the prominences abound, and where they are least frequent. A similar work has been carried on in England during the last few years at Stonyhurst College Observatory by Perry.

It appears evident from the comparison of these observations with those of sun-spots that the hydrogen prominences correspond both as to distribution in latitude and frequency of appearance much more nearly with the faculæ than with the spots; indeed, the last maximum for prominences fell very distinctly later than was the case with the Sun-spots. The metallic eruptions, on the other hand, are clearly connected much more nearly with the spots; they are restricted to the same zones, and vary at the same time and in the same manner.

The prominences are usually observed upon one or other of the hydrogen lines; more commonly on the C line. But though the hydrogen lines, with D_3 , are the most conspicuous lines in the spectra both of the prominences and of the chromosphere, they are far from being the only lines which either show. The ordinary chromospheric spectrum contains according to Young the lines given in the following list^z, in which they are designated by their wave-lengths, as given by Ångström:—

1.	7055 +	Element unknown.
2.	6561.8 C	Hydrogen (H α).
3.	5874.9 D ₃	Unknown element. Frankland's " <i>Helium</i> ."
4.	5315.9	The corona-line; element unknown.
5.	4860.6 F	Hydrogen (H β).
6.	4471.2 f	Cerium (?).

^z *The Sun*, p. 193.

7.	4340.1 near G ^a	Hydrogen (H γ).
8.	4101.2 <i>h</i>	Hydrogen (H δ).
9.	3969 (?)	Element unknown.
10.	3967.9 H	Hydrogen, probably.
11.	3932.8 K	Hydrogen, probably.

Besides these 11 lines, which are always seen when the sky is sufficiently clear, Young gives a further list of 31 which frequently make their appearance, but expressly notes that their selection is to some extent an arbitrary one, for several others are seen almost as often ^b. They are as follows:—

1'. 6676.9 Fe.	12'. 5172.0 <i>b</i> ₂ Mg.	23'. 4490.9 Mn.
2'. 6429.9 ?	13'. 5168.3 <i>b</i> ₃ Fe. Ni.	24'. 4489.4 Mn. Fe.
3'. 6140.6 Ba.	14'. 5166.7 <i>b</i> ₄ Mg.	25'. 4468.5 Ti.
4'. 5895.0 D ₁ Na.	15'. 5017.6 Fe. Ni.	26'. 4394.6 ?
5'. 5889.0 D ₂ Na.	16'. 5015.0 ?	27'. 4245.2 Fe.
6'. 5361.9 Iron.	17'. 4933.4 Ba.	28'. 4235.5 Fe.
7'. 5283.4 ?	18'. 4923.1 Fe.	29'. 4233.0 Fe. Ca.
8'. 5275.0 ?	19'. 4921.3 ?	30'. 4215.0 Ca. Sr.
9'. 5233.6 Mn.	20'. 4918.2 Fe.	31'. 4077.0 Ca.
10'. 5197.0 ?	21'. 4899.3 Ba.	
11'. 5183.0 <i>b</i> ₁ Mg.	22'. 4500.5 Ti.	

It is no easy matter to observe these fainter lines well. Not only must the collimator and viewing telescope of the spectroscope be in perfect focus for the part of the spectrum under examination, but the slit must be in the focus of the object-glass of the equatorial for the same ray. Whilst for picking up prominences a radial slit will be found the best, for this work a tangential slit is necessary, and the greatest care is needed that the limb of the Sun is just outside it, and only just outside. Lastly, the definition must be good, the images steady, and the neighbourhood of the Sun free from white haze. The importance of good atmospheric conditions will be seen when it is remembered that, from the mountain station at Sherman, Young in a few weeks was able to make out a list of 273 lines reversed in the chromosphere, and Thollon from the Pic du Midi observed 36 between D and F ^c.

^a Frequently called G, although Fraunhofer's G is some little distance further towards the violet. As it is convenient to have a letter for the line, Maunder

has designated it here by an italic *G*.

^b *The Sun*, p. 194.

^c *Comptes Rendus*, vol. xcvii. p. 834. Oct. 15, 1883.

A total eclipse of the Sun affords an opportunity of obtaining yet further information respecting the chromosphere, and not the chromosphere alone (for by that term is usually understood the continuous ring, some 8" in height, seen round the entire disc), but respecting all the solar appendages. For, the moment the Sun is hidden by the Moon and the overpowering glare of its light is withdrawn, the fainter light of its surroundings can be perceived. At the very instant of its disappearance a most beautiful phenomenon is witnessed,—the spectrum of the "flash" as it is termed, for it lasts but a second or two,—the bursting out of multitudes of short bright lines, the correspondents, it is generally supposed^d, of the dark lines of the ordinary solar spectrum; in fact, it is, roughly speaking, the spectrum of the reversing layer, and from the rapidity with which it is covered by the Moon, it must be under 1000 miles in depth.

This beautiful effect was first seen in 1870 by Young and Pye and has often been remarked since. But it must not be supposed that the whole or indeed the principal part of the absorption revealed to us by the Fraunhofer lines takes place in this layer. Were this so the dark lines would be much more intense near the limb of the Sun, for we should there be looking through a greater depth of the solar atmosphere. Since on the whole they are not much darker there, it is generally held that the principal absorption takes place at the very level of the photosphere. On this view the photosphere is composed of glowing clouds, due to the condensation of the metallic vapours as rushing upwards they reach the higher regions of the solar atmosphere, and the chief absorption is due to that atmosphere in which they float and takes place in the intervals between them.

But total eclipses have revealed to us the fact that the Sun possesses appendages on all sides which rise far above the chromosphere, far above even the loftiest prominences. The

^d Lockyer disputes this. "It has been called the reversing layer," he says, "but I do not believe it is the reversing layer for a moment, for when it comes to be examined we shall probably find that

scarcely any of the Fraunhofer lines owe their origin to it, and we shall have a spectrum which is not a counterpart of the solar spectrum."

strange and beautiful halo we term the corona is revealed to us then, and since it is only at such times that it can be studied, the chief interest of total eclipses has centred in its observation.

The spectrum of the corona consists of at least 3 superposed spectra, which Huggins describes as follows^o:—

“(a) A bright continuous spectrum, which informs us that it comes from incandescent solid or liquid matter.

“(b) A solar spectrum, which shows that the incandescent solid or liquid matter of the corona reflects to us light from the photosphere.

“(c) A spectrum of bright lines, which is relatively faint and varies greatly at different eclipses. . . . This spectrum . . . tells us of gaseous matter which accompanies the solid or liquid matter. It is scarcely necessary to say that solid or liquid matter can exist in the corona only in the form of discrete particles of extreme minuteness. The corona must, therefore, consist of a fog in which the particles are incandescent and in which the gaseous matter does not form a continuous atmosphere.”

To these spectra, of which the 3rd is itself very complex, we may perhaps have to add a 4th, a bright banded spectrum. Lockyer, speaking of the complicated nature of the coronal spectrum as seen in 1882, remarks that “there were maxima and minima producing an appearance of ribbed structure, . . . as if all the banded spectra I had ever seen were superposed.”

Of the bright line spectrum the most characteristic is a line in the green, 1474 on Kirchhoff's scale, and hence usually spoken of as “1474 K.” Nearer the Sun a stratum of hydrogen is found at a lower temperature than in the chromosphere and prominences. At or near minimum the bright line spectrum is practically confined to 1474 K and the hydrogen lines, at or near maximum an immense number of other lines are seen. The following, for example, were seen in a photograph of the 1882 eclipse:—

4526.	4289.	4168.
4501 double (?).	4267.	4101 h, H δ.
4473.	4252.	4085.
4442.	4241.	4067.
4414.	4224.	4057.
4401 short.	4212.	4044.
4395.	4195.	4015.
4370 short and winged.	4179.	3992 comparatively strong.
4340 H γ.	4173.	3948.

^o *The Bakerian Lecture, 1885, Proc. Roy. Soc., vol. xxxix. p. 121.*

Schuster in 1886 succeeded in taking a photograph showing between 40 and 50 distinct coronal lines between F and H, besides fainter ones. In general the lines seemed to be the same as those seen in the 1882 eclipse, but their relative intensity was much altered; the strongest coronal line in 1886 being that at 4232·8, probably the same line as 4233 often observed by Young in the chromosphere^f.

An important feature of recent eye-observation of solar eclipses has been the recording of the order in which the bright lines appear and the height which they severally attain. The result of these observations has been on the whole greatly to strengthen Lockyer's view that the various strata of the solar atmosphere give markedly different spectra. The brightest lines, the lines seen earliest and latest, are the shortest lines; they are therefore the lines of the lower strata, and they correspond to the lines seen in prominences. The longer and fainter lines, the lines that is of the upper strata, more nearly represent the lines affected in spots. The observations made by Lockyer to this effect in Egypt in 1882 were repeated and substantially confirmed by Turner in 1886 at Grenada.

We have at present no knowledge as to the substance producing the 1474 K line. Two other lines in the greenish yellow have been somewhat doubtfully connected with it, the one at about wave-length 5570, the other about 5450. The former is close to the principal line of the spectrum of the Aurora, and Young was for a time misled into believing that 1474 K was also an auroral line, and hence that the two spectra were to a considerable extent identical. This, as he has since pointed out^g, is not the case. 1474 K was for a short time believed to be coincident with a line of iron. More powerful spectroscopes have enabled us to divide the solar line supposed to be common to the two spectra, and to show that the iron line is the less refrangible and the coronal line the more refrangible of the two components; 1474 K may therefore be taken to reveal the existence

^f *Proc. Roy. Soc.*, vol. xlii. p. 181, March 17, 1887.

^g *The Sun*, p. 233.

of a gas, as yet unknown to us, much lighter than hydrogen, and very widely diffused throughout the coronal region in a state of great tenuity.

The spectrum of the Zodiacal Light has been differently reported on by different observers, but the general testimony points to its being in the main faintly continuous. The principal auroral line has been seen by Ångström, Vogel, and Wright, but the latter considers that it was due to the presence of Aurora, and that it did not strictly belong to the Zodiacal spectrum. Burton found the continuous spectrum to be interrupted by a dark line of wave-length about 5355, and to be terminated towards the red by a bright line about 5673. Burton's inference from these observations was that the Zodiacal Light was emitted by matter partly liquid, and partly solid, intermixed with gas, and that it formed a flat ring surrounding the Sun, and extending as far as and probably beyond the orbit of the Earth^h.

^h *Proc. Royal Irish Acad.*, 2nd Ser., vol. ii. p. 218.

CHAPTER III.

SPECTROSCOPY AS APPLIED TO PLANETS AND COMETS

Spectrum of the Moon.—Traces of atmospheric absorption in Mars.—Spectrum of the eclipsed Moon.—Spectra of Jupiter and Saturn.—Spectrum of Uranus.—Taylor's observation of bright lines.—Spectrum of Neptune.—Of the Rings of Saturn.—Spectra of Comets.—The ordinary type.—The Comets of Tebbutt and Schüberle.—Wells's Comet.—The Great Comet of 1882.—Spectra of Meteors.—Lockyer's researches on the spectra of Meteorites.

THE Spectroscope can tell us comparatively little about the planets, for as they shine, at all events principally, not by their own, but by reflected light, their spectra are, for the most part, the reflection of that of the Sun. So that all we can learn is whether this has been modified by any absorptive property of their several atmospheres.

The Moon, however, shows no sign of any modification of this kind; this evidence, as far as it goes, therefore negatives the theory of a lunar atmosphere. But an observation of Huggins's is much more decisive. He watched the occultation of a star by the dark limb of the Moon. Now if the star had suffered any appreciable refraction by a lunar atmosphere, the violet end of the spectrum would have been visible a little longer than the red, as it would have been more refracted. But nothing of the kind was noticed, the entire spectrum vanishing at once^a.

The three smaller planets, Mercury, Venus, and Mars, give the usual solar spectrum, but in addition, there have been noticed bands agreeing in position with some of the telluric bands, particularly

^a *Month. Not.*, vol. xxv. p. 60. Jan. 1865.

in the red, and, in the case of Mars, near D. It is of course by no means easy to make sure that these are not occasioned by the action of our own atmosphere; but the careful observations of Huggins, Vogel and others have rendered it probable that they are really due to the atmosphere of the planet under inspection. In the case of Mars, Huggins saw these lines when the Moon, which was considerably lower in the heavens, was free from lines^b, and Maunder has more recently repeated the observation. The latter found B, α , δ and the telluric lines around C and D to be a little darker and broader as seen in the spectrum of the planet than as seen in that of the Moon, the latter being somewhat lower in the heavens^c.

There is one occasion on which some interest attaches to the lunar spectrum, *i. e.* during an eclipse of the Moon. The light by which the Moon then shines being sunlight which has passed through a double depth of the Earth's atmosphere, we find, as might be expected, that the telluric bands appear at such a time of most abnormal depth and distinctness. Thus the "dry-air" band δ was observed by Christie and Maunder to be of most unusual breadth during the total eclipse of August 1877^d, whilst the violet and red ends were entirely cut off, the former apparently either by bands ι or κ of the Brewster-Gladstone spectrum, the latter by band α .

Jupiter and Saturn, like the smaller planets, show traces of absorption by aqueous vapour, in addition to the reflected solar spectrum.

But in addition there is a band in both spectra at about wavelength 6178.5 which cannot be assigned to either of these origins, and hence we may conclude that the atmospheres of these planets contain some vapour or gas unknown to us. Vogel suspects the presence of the same band in the spectra of satellites II. and IV. of Jupiter^e.

It will be seen at once that the presence of this band, which

^b *Month. Not.*, vol. xxvii. p. 178. March 1867.

^c *Greenwich Spectroscopic Obs.*, 1877, p. 102.

^d *Greenwich Spectroscopic Obs.*, 1877, p. 102.

^e *Untersuchungen über die spectra der Planeten*, p. 32. Leipzig, 1874.

is a fairly distinct one, renders it highly probable that the two giant planets still emit some light of their own, for it is patent that the light which they send to us bears a very considerably higher proportion to the amount which they receive than is the case with the Moon or Mars, and yet the absorption exercised by the planet's atmosphere is manifestly much greater also.

But the argument in favour of some degree of inherent luminosity becomes much stronger when we turn to the two outermost planets, Uranus and Neptune. The faintness of their light does not permit the Fraunhofer lines to be seen, though Huggins has recently obtained them in a photograph of the spectrum of Uranus; nor are the telluric bands noticeable.

Fig. 160.

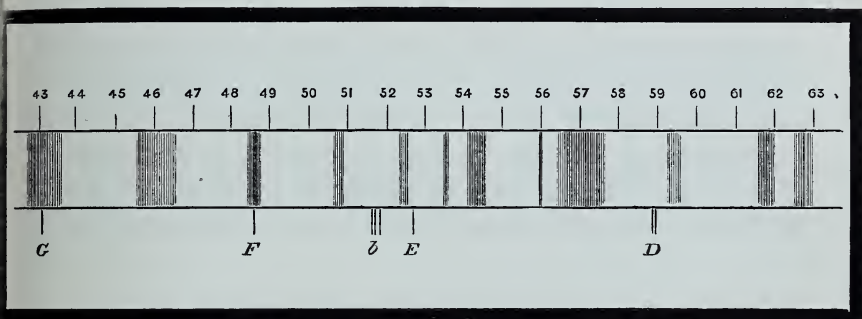

SPECTRUM OF URANUS, ACCORDING TO VOGEL.

In the case of Uranus however 6 strong bands were noticed by Huggins^f; and Vogel, who confirmed the observation, added a few fainter ones. One of the darkest is coincident with the blue-green line of hydrogen, but none of the others have been certainly identified. Another strong band is coincident with the one remarked in the spectra of Jupiter and Saturn.

Quite recently Taylor, observing with Common's great 5-foot reflector, believes that he has obtained distinct and unmistakeable evidence of the presence of bright lines and flutings.

The general form of the light curve of the spectrum as given

^f *Proc. Roy. Soc.*, vol. xix. p. 489, May 25, 1871.

by Taylor closely agrees with that of the spectrum as previously observed by Huggins and Vogel, and the immense light-gathering power of the great mirror would explain the distinctness of the bright lines as seen by him, as compared with the uncertain or negative results of the earlier observers. The recent photograph by Huggins, however, reveals no lines, bright or dark, beyond those of the solar spectrum. It would appear therefore that the bright lines, if real, are confined to the less refrangible regions; or in other words, that the temperature of the planet is not sufficiently high for its own intrinsic spectrum to extend far into the blue.

The light of Neptune is almost too faint for spectroscopic examination, unless aided by a giant telescope like that of Common. It appears from the observations of Vogel and Maunder that the spectrum is substantially the same as that of Uranus, but that probably the absorption-bands are more distinct when allowance is made for the feebler brightness.

In the case of Saturn's rings Huggins finds that the bands due to aqueous vapour are less distinctly marked in the spectra of the ansæ than in the spectrum of the ball, thus showing that the absorptive power of the atmosphere surrounding the planet is greater than that of the atmosphere surrounding the rings^h.

In the case of perhaps no class of heavenly bodies has the spectroscope yielded to us information of so entirely an unexpected nature as in that of comets. The first comet the spectrum of which was observed was Comet i. 1864 by Donati, who found it to yield only 3 bright lines, showing the presence of a glowing gas. Huggins and Secchi in 1866 found Tempel's comet give likewise 3 bright lines and a continuous spectrum in addition. No dark lines were perceived in the latter, the light being probably too faint to enable them to be seen. But in the continuous spectrum yielded by Coggia's comet of 1874, as observed by Christie at Greenwich, some dark lines were seen, and therefore it is reasonable to conclude that the continuous spectrum given by comets is simply due to reflected sunlightⁱ.

^h *Brit. Assoc. Report*, 1868, p. 143.

ⁱ *Month. Not.*, vol. xxxiv. p. 491. 1874.

It was an important advance to be thus informed that the light of the comet came from two sources, the one the Sun itself, by reflection; the other peculiar to the comet itself. But the spectroscope speedily revealed a further and unsuspected fact. The truly cometary light was due to glowing hydro-carbon vapour. For Huggins^k and Secchi in examining the head of Winnecke's comet in 1868 saw 3 shaded bands, besides the continuous spectrum, and on comparing them with the spectrum of olefiant gas, found that they were exactly coincident with the 3 principal bands of the hydro-carbon spectrum, agreeing with them not merely in position, but in general appearance and in the manner in which they faded away. The observations of Coggia's comet

Fig. 161.

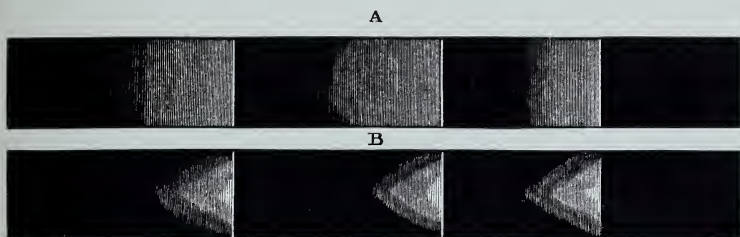

SPECTRA OF OLEFIANT GAS AND WINNECKE'S COMET, 1868.

A, Spectrum of Olefiant Gas; B, Spectrum of Comet.

yielded the same result. Since then a great number of comets have been subjected to spectroscopic scrutiny with results which are, on the whole, in remarkable accordance. Two comets however stand out from the rest,—Brorsen's Comet as observed by Huggins in 1868, and Comet iii. of 1877 as observed by Copeland at Dun Echt. Excluding these, all the others have shown three bright bands coincident with one or other of the carbon spectra.

The question however arises, with which of the carbon spectra do the cometary spectra agree? With regard to the later-observed and brighter comets the testimony is very clear; the spectrum has been that given by the blue base of a candle-flame,

^k *Phil. Trans.*, vol. clviii. p. 555. 1868.

or by a Bunsen burner; the spectrum which Lockyer terms that of *hot* carbon, but which Hasselberg and others consider as characteristic of a hydro-carbon, probably of acetylene. The wave-lengths of the three principal bands of this spectrum are given by Thalén as 5633 for the band in the yellow, 5164 for that in the green, and 4736 for that in the blue respectively. But the complete spectrum contains 5 bands, one in the red at 6187 and one in the violet at 4311. These have not often been detected in the spectra of comets, but in the case of one or two of the brightest, the first instance being that of Coggia's comet in 1874 when Secchi recognised their presence, they have been successfully made out. It appears therefore that it is only a question of brightness, and that the whole series may be expected to be shown by any comet of sufficient brilliancy.

For some of the earlier and fainter comets the bright bands were recorded by some observers as coincident with that spectrum of carbon called by Lockyer that of *cool* carbon, by others that of carbonic oxide, in distinction to the hydro-carbon spectrum referred to above. The wave-lengths of the bands in this spectrum are as follows:—yellow, 5610; green, 5198; blue, 4834. It is not yet absolutely certain whether these observations are to be accepted or not. It appears very probable in some cases, if not in all, that the faintness of the spectrum forbade any accurate measurement of the cometary bands, and that being compared with the carbonic oxide spectrum with but low dispersion, and a close approximation being noted, it was assumed that the correspondence was exact. Thus Christie observing the spectrum of Hartwig's comet on Oct. 7, 1880¹, measured the green band as at wave-length 5201, or as being the band of the carbonic oxide spectrum: four days later he measured the same band as at 5169, or as being the band of the hydro-carbon spectrum; and on Oct. 12 the observation was repeated. A comparison of the individual measures renders it all but certain that there was no change in the place of the cometary band, and that the difference in the positions recorded

¹ *Greenwich Spectroscopic Obs.*, 1880, p. 62.

was due entirely to the difficulty of securing an accurate measurement of an object so faint and so diffused.

Hasselberg reviewing the observations of the first 18 comets subjected to prismatic analysis concludes^m:—

(1.) That all observed cometary spectra belong to one type, with the exception of the two doubtful cases of Comets i. 1868, and iii. 1877, noted above.

(2.) That this type is that of the hydro-carbons.

(3.) That they deviate from the type in being incomplete; and, in general, in the relative brightness of the bands.

(4.) They are incomplete in so far as the red and violet bands of the hydro-carbons are wanting, and also that the maximum brightness of the bands is not at the less refrangible edge, but somewhat towards the violet.

(5.) This circumstance explains why in the case of faint comets the connexion with hydro-carbon spectra has appeared doubtful.

(6.) The displacement of the maxima of the bands of most comets, with regard to those of hydro-carbons, is approximately the same; therefore it seems probable that the differences of the physical conditions of the hydro-carbons in the comets, from those which have hitherto been obtained in observations of hydro-carbon spectra, are approximately the same.

The observation of the red and violet bands in Coggia's comet and in several more recent bright comets meets the allegation of incompleteness made above in (4.); whilst the shift of the maximum brightness from the edge of the cometary band towards the violet admits often of a very simple explanation. To observe a faint comet the slit of the spectroscope must be opened wide, and probably the light from the whole of the head or from a considerable portion of it will be embraced within the opening. This will not be of one homogeneous brightness throughout, but will fade outwards from the centre; there will be more light near the centre of the slit opening than close to either jaw, and

^m *Mém. Ac. Imp. de St. Petersbourg*, Series vii. vol. xxviii. No. 2; *Copernicus*, vol. i. p. 83.

consequently the cometary bands will not only degrade towards the violet, but to a slight extent towards the red as well, throwing the maximum towards the violet. In bright comets when a very narrow slit can be used, and when therefore the entire breadth of the slit is filled with light of practically the same intensity, this discrepancy between the spectra of the comet and of the hydro-carbon disappears. Maunder writes thus in regard to Tebbutt's Comet of 1881:—

“With the spectra of the Comet and of the Bunsen-flame arranged one above the other, and the flame adjusted until the bright sharp edge of the green band was of the same intensity in each, the resemblance between the two spectra was exceedingly striking, the three principal bands corresponding exactly in position, in brightness, and in the manner and degree in which they shaded off towards the violet.”

If this be the correct explanation, there will be no reason to suppose, as in paragraph (6.), that the displacement arises from any peculiarity in the physical condition of comets. The displacement will be apparent only and due to the difficulties of observation.

Beside these shaded hydro-carbon bands, comets generally give a continuous spectrum from the nucleus and the immediate neighbourhood. This is largely due to reflected sunlight, the Fraunhofer lines having been detected on favourable occasions.

The years 1881 and 1882 were especially remarkable for the fine comets which were then visible. Comet iii. of 1881, discovered by Tebbutt, proved especially interesting as the first which was itself successfully photographed, and the first of which the spectrum was photographed, the former feat being accomplished by Janssen, the latter by Huggins and by H. Draper. As first seen in Northern latitudes, the spectrum of Tebbutt's comet was almost purely a continuous one; it was some few days before the cometary bands began to show themselves. But as the nucleus faded they became more apparent, and their precise coincidence with the bands from a Bunsen-flame was rendered evident. The continuous spectrum on June 29 showed the Fraunhofer lines, F being unmistakably present. But the photographic plate had anticipated the eye of the observer, Huggins's negative taken on June 24 showing in the ultra-violet region both the hydro-carbon

bands and the solar absorption lines, and proving that the spectrum in the visible portion and that beyond the reach of the eye were essentially the same.

The spectrum of the tail of this comet was also examined, and both Vogel and Young traced the carbon bands far down its length, the former indeed to its very end. Probably the spectrum of reflected sunlight was also present, though Young could not trace it so far as he could the gaseous flutings.

Comet iv. of 1881 (Schäberle's) formed a striking contrast to Tebbutt's, in that it gave almost a pure spectrum of bands. The hydro-carbons were strongly in evidence; of reflected sunlight there was scarcely a trace.

Both these comets afforded to Copeland and Lohse a further proof of the origin of their banded spectra, for these observers were able not merely to see simple shaded bands, but to break them up into true flutings precisely as the hydro-carbon spectrum can be resolved.

The comets of 1882 were yet more important. All the comets which had been previously examined had considerable perihelion distances; Comets i. and ii. of 1882 both approached very near the Sun, the latter all but grazing its surface. The former, known from its discoverer as Wells's Comet, at first showed an almost purely continuous spectrum. The nucleus of the comet was greatly condensed, and to direct eye observation and as seen through the prism it presented a very stellar appearance. On May 27 Copeland suspected the presence of a bright line; the next night the line was seen to be coincident with the D line, and on May 29 Copeland published the following noticeⁿ:—

“The spectrum of the nucleus of Wells's Comet deserves the closest attention, as it shows a sharp bright line coincident with D, as well as strong traces of other bright lines, resembling in appearance those seen in the spectra of γ Cassiopeïæ and allied stars.”

Copeland and Lohse followed the comet from this time day by day till its perihelion passage on June 10, and had the gratification of seeing the bright sodium lines, D, develope in the most

ⁿ *Copernicus*, vol. ii. p. 229.

striking manner. On June 6, the D lines were seen beautifully double, and the continuous spectrum was so much the less important, the light of the comet was so nearly monochromatic, that with a wide slit Lohse was able to see "the perfect image of the comet, head and tail, . . . in the light of the D line, very bright and clear. . . . The sight was really magnificent ; exactly like a prominence."

Other bright lines were observed, especially in the red, and there were faint traces of the ordinary carbon bands. But the sodium light was predominant, and next to that, the general continuous spectrum.

The second comet of 1882, justly called the Great Comet, approached the Sun much nearer than Wells's Comet had done ; and inferring that the development of sodium light in the spectrum of that body had been due to the heat it experienced as it approached the Sun, Copeland and Lohse naturally expected to find the D lines bright also in the spectrum of this new visitor. The inference was abundantly justified. "The expected bright sodium lines exhibited themselves to the eye of the observer with a brilliancy and neatness quite comparable to the C line in prominences, so well defined and clear did they stand out on the bright daylight spectrum." But besides the D lines a number of other bright lines were seen, notably the E lines and some other prominent iron lines, together with 5 lines in the red which had no counterparts in the dark lines of the solar spectrum. Four of these lines had the following wave-lengths, 6028, 5958, 5934, 5922 ; the fifth line, which lay between the first and second, was not measured.

A beautiful illustration was afforded by this comet of the effect of the motion of a body on the lines of its spectrum. The comet was receding from the Earth at this time, and the lines of its spectrum were therefore displaced a little towards the red, the bright D and E lines being seen therefore just on the redward side of their dark counterparts in the solar spectrum. This observation was not only made by Copeland and Lohse, at Dun Echt, but on the same day, Sept. 18, by Thollon and

Gouy at Nice; and in both cases the displacement was estimated to be about $\frac{1}{4}$ or $\frac{1}{5}$ the distance between the D lines, a displacement which would correspond to a motion of about 42 miles per second. The actual motion of recession of the comet was about 45 miles per second °.

As the comet receded from the Sun the various bright lines faded away, the D lines lasting longer than the others, whilst the carbon bands came into greater prominence. There is every reason to believe that these changes are strictly typical; and that we may expect comets of short perihelion distance to show, first, the hydro-carbon spectrum; then, when in the neighbourhood of the Sun, the sodium lines; and lastly, when at closest approach, a number of other metallic lines, and particularly those of iron. Lockyer carries this view of the successive changes of cometary spectra much further, and has drawn up a long list of the successive phases presented by the spectrum of a comet as the body approaches or recedes from the Sun^p. This is partly founded on discrepancies as to the positions of some of the bands which may prove to be significant, but which more probably are simply due to the difficulties of observation, and partly to the fact that the yellow band of the carbon series in cometary spectra does not always show the same exact correspondence with the carbon band as do those in the green and blue. In particular it shows at times two or more maxima within its borders, and its redward edge is rather diffused. The positions of these maxima are variously given, but appear to be about 5570 and 5450. There are not a few instances also in which this yellow, or rather citron band, has been recorded as having its sole maximum at one or other of these wave-lengths. Lockyer ascribes these divergences to the influence of the flutings of manganese and lead, but bearing in mind the great difficulty of many of these observations, and that the citron band is much the faintest of the 3, it seems scarcely safe at present to draw such an inference.

° *Comptes Rendus*, vol. xcv. p. 555, Sept. 25, 1882; and p. 712, Oct. 23, 1882.

^p *Proc. Roy. Soc.* vol. xlv. p. 190, Jan. 10, 1889.

The labours of Schiaparelli and others have taught us to associate closely meteors with comets, and we now know of numerous instances in which a comet and a meteor stream are actually travelling on the same orbit. It might be expected that there would be some resemblance between the spectra of the two classes of bodies. But the rapid motion and evanescent character of meteors makes their spectroscopic observation exceedingly difficult. Browning however succeeded in observing no fewer than 70 in August and November 1866, with an instrument constructed by himself for the purpose^q. This consisted simply of a direct-vision compound prism, and a plano-concave cylindrical lens; the latter being intended to diminish the apparent angle through which the meteors fell. The heads of the meteors gave spectra mostly continuous, though with frequent differences in the relative preponderance of the colours. In the tails, in every instance, orange-yellow light predominated, from which the presence of sodium may probably be inferred, a result confirmed by A. S. Herschel. Konkoly looks upon this presence of the sodium line as possibly due rather to particles floating in our air and becoming incandescent with the meteor than to any constituent of the meteor itself. But the same observer in the spectrum of a magnificent fireball on Oct. 13, 1873, observed not merely the sodium lines, but also bands which he was able to identify by direct comparison with the spectrum of a hydrocarbon^r, thus affording an evidence from the spectroscopic side of the connection between comets and meteors; and remembering the brilliant sodium lines of the comets of 1882, it does not seem improbable that meteors should show this metal also.

Other metallic lines have also been observed. Secchi detected magnesium in the spectra of two meteors in 1868. Konkoly has often remarked it, and the lines of lithium and potassium have been seen by him once or twice, together with two or three other lines which he was disposed to ascribe to iron and copper.

^q *Month. Not.*, vol. xxvii. p. 77. Jan. 1867. The word "lightning gas" is a misprint for "lighting gas," that is to say, coal gas.

^r *Month. Not.*, vol. xxxiv. p. 82. Dec.

These observations have been supplemented by Lockyer, who has recently given great attention to the spectra of meteorites, and his results have confirmed the meteor observations of Konkoly and opened out questions of the greatest interest. From meteorites in the oxy-hydrogen flame he obtained only about ten or a dozen lines belonging to magnesium, iron, sodium, lithium and potassium, and two flutings, one of manganese and one of iron. With a quantity coil without a jar more lines were seen, and barium, calcium, strontium, chromium, zinc, bismuth and nickel, besides magnesium, sodium and iron, were recognised. But the most interesting results were obtained from heated fragments of a meteorite in a vacuum tube when a current was passing along it. The result of these experiments appeared to Lockyer to show that under suitable conditions of temperature there can be obtained from meteorites spectra corresponding to almost every varied example presented to us by the different orders of heavenly bodies. From this circumstance he has concluded^s that:—

“(1) All self-luminous bodies in the celestial spaces are composed of meteorites or masses of meteoritic vapour produced by heat brought about by condensation of meteor-swarms due to gravity.

“(2) The spectra of all such bodies depend upon the heat of the meteorites, produced by collisions and the average space between the meteorites in the swarm, or in the case of consolidated swarms, upon the time which has elapsed since complete vaporisation. . . .

“(7) The existing distinction between stars, comets, and nebulae rests on no physical basis.

“(8) The main factor in the various spectra produced is the ratio of the interspaces between the meteorites to their incandescent surface.” . . .

Lockyer's experiments certainly show that meteorites contain the same elements as we meet with in terrestrial substances, and as we recognise in the spectra of the heavenly bodies, but that they do more than this has been strongly contested, and the matter still awaits further elucidation.

^s *Proc. Roy. Soc.*, vol. xliii. p. 152, Nov. 17, 1887.

CHAPTER IV.

SPECTROSCOPY AS APPLIED TO STARS AND NEBULÆ.

Elements discovered in Stellar Spectra.—Types of Spectra.—Secchi's classification.—Brighter Stars of the different Types.—Vogel's classification.—Lockyer's.—Relation of the three methods.—Bright-line Spectra.—Temporary Stars.—T Coronæ.—Nova Cygni, 1876.—Nova Andromedæ, 1885.—Spectra of Nebulæ.—Connection with Meteorites.—Motions of Stars in the line of sight.—Comparison of results obtained at different Observatories.—Motion of Sirius.—Observations of Algol.

SHORTLY after Kirchhoff had commenced his work of comparing the spectra of various elements with that of the Sun, Huggins and Miller applied the same method to ascertain the nature of the elements contained in the stars. The conditions of work were however widely different in their enterprise from what they had been in Kirchhoff's. It was no longer the blaze of sunlight, but the tiny glimmer of a star that had to be spread out into a long spectrum. Indeed it was necessary still further to weaken the feeble light by a cylindrical lens, in order to give the spectrum a sensible width; for otherwise a star spectrum would be merely a coloured line, stars having no appreciable diameter.

The extreme difficulty and delicacy of this work can hardly be appreciated by any one who has not actually tried it, and it reveals a patient laboriousness on the part of these observers not to be surpassed. The results of their observations in the case of Aldebaran and Betelgeuse are thus given by Huggins:—

ELEMENTS COMPARED WITH ALDEBARAN.

Coincident.

1. Hydrogen with lines C and F.
2. Sodium with double line D.
3. Magnesium with triple line *b*.
4. Calcium with four lines.
5. Iron with four lines and E.
6. Bismuth with four lines.
7. Tellurium with four lines.
8. Antimony with three lines.
9. Mercury with four lines.

Not coincident.

Nitrogen compared with 3 lines.			
Cobalt	„	„	2 „
Tin	„	„	5 „
Lead	„	„	2 „
Cadmium	„	„	3 „
Barium	„	„	2 „
Lithium	„	„	1 „

ELEMENTS COMPARED WITH BETELGEUSE.

Coincident.

1. Sodium with double line D.
2. Magnesium with triple line *b*.
3. Calcium with four lines.
4. Iron with three lines and E.
5. Bismuth with four lines.
6. Thallium (?).

Not coincident.

Hydrogen compared with C and F.			
Nitrogen	„	„	3 lines.
Tin	„	„	5 „
Lead	„	„	2 „
Gold (?)			
Cadmium	„	„	3 „
Silver	„	„	2 „
Mercury	„	„	4 „
Barium	„	„	2 „
Lithium ^a	„	„	1 „

The hydrogen line F though faint has since been identified in one of the clusters of the spectrum of Betelgeuse.

Three elements are found in nearly all the stars that have been examined, viz. sodium, magnesium, and hydrogen. Iron is also frequently found, Sirius, Vega, and Pollux giving evidence of all these 4 elements, whilst Arcturus shows calcium and chromium in addition^b. We therefore conclude that most of the stars resemble our Sun in that they possess a photosphere giving a continuous spectrum and surrounded by the absorbent vapours of elements, many of which are well known to us.

The study of the spectra of the stars soon revealed well-marked differences between them. Fraunhofer, as we have already seen, recognised that they were by no means repetitions of the solar spectrum, and inferred therefore that the dark lines they presented were due to some cause in the star itself, and not in the earth's atmosphere or in interstellar space. Rutherford, and after him Secchi, noticed that the spectra of the stars could be grouped into a small number of classes after certain well-

^a *Brit. Assoc. Rep.*, 1868, p. 144.

^b *Beobachtungen angestellt auf der Sternwarte zu Bothkamp.* 1872.

defined and strongly distinguished types. Vogel, and more recently Lockyer, have carried this work of classification further, but their schemes involve rather a development than a setting aside of Secchi's. Whatever be the best theoretical arrangement, the four types pointed out by Secchi are undoubtedly based upon the features which are most characteristic in appearance, and the later classifications do not fail to recognise them as such. Secchi's 4 types may be briefly described as follows^c:—

(I.) The white stars of which Sirius and Vega are the types, yielding spectra crossed by 4 broad dark lines due to hydrogen, and much broader than those in the solar spectrum. Other fainter lines may be seen, but only with the most powerful and perfect instruments. The lines of sodium and magnesium however are sufficiently marked in the brightest stars to be easily identified.

(II.) The IInd class, embracing almost all the other lucid stars, consists of the yellow stars of which our sun is an example. In these spectra the hydrogen lines are much less conspicuous, but the metallic lines are numerous, those of magnesium being often very distinctly marked. Aldebaran, Capella, Pollux, Arcturus, and α Cygni belong to this class.

(III.) The IIIrd type yields exceedingly beautiful spectra, crossed in the most perfect specimens by 10 or more dark bands, each band being very dark and sharp at the end nearer the violet and gradually growing fainter towards the red. α Herculis, the most superb of all, α Orionis, and Antares, are the principal stars of this type. The bands are resolvable into individual lines and their sharp edges seem to occupy the same position in all the stars of the type, one of them being marked by the magnesium line b_4 , and many of the others by lines of calcium or iron^d.

(IV.) The IVth type are the red stars, which show 3 broad dark bands, shaded in the reverse direction to those of the third type. These bands coincide in position with the three well-known hydrocarbon bands, so readily obtained from a Bunsen flame. This type of spectrum is therefore the reversal of the

^c *Brit. Assoc. Report*, 1868; and *Spettri prismatici delle stelle fisse*. Roma, 1868.

^d Dunér, *Sur les Etoiles à Spectres de la Troisième Classe*, p. 121.

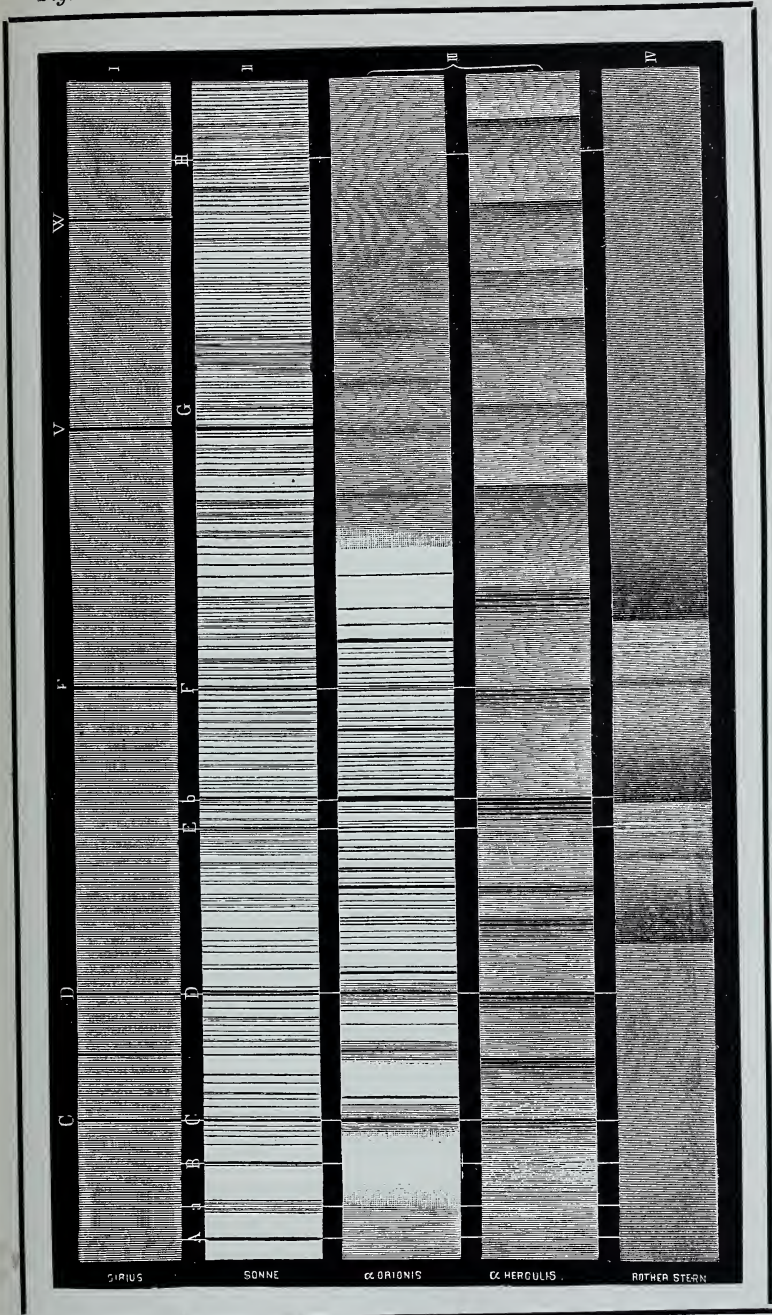

SECCHI'S TYPES OF STELLAR SPECTRA.

No.	Name	Age	Sex
1	John Smith	25	M
2	Mary Jones	30	F
3	James Brown	18	M
4	Elizabeth White	45	F
5	Robert Black	22	M
6	Sarah Green	35	F
7	William Grey	15	M
8	Jane Hill	40	F
9	Thomas Lee	28	M
10	Anna King	32	F
11	George King	12	M
12	Elizabeth King	10	F
13	John King	8	M
14	Mary King	6	F
15	James King	4	M
16	Sarah King	2	F

ordinary cometary spectrum, the carbon being evidenced by its absorption instead of its emission. There are some other bands in the red and yellow which may be due to aqueous vapour, as they seem to coincide with the principal bands due to aqueous vapour in the telluric spectrum^e.

Besides these 4 types Secchi pointed out a fifth class, viz. stars showing bright lines in their spectra. γ Cassiopeiæ, β Lyræ, and η Argûs are the brightest stars of this order, of which as yet we have but few specimens, but fresh examples are continually being discovered.

The following are the principal representatives of each of the 4 types^f:—

Type I.— a, μ Andromedæ; ζ Aquarii: $a, \delta, \zeta, \eta, \theta, \lambda$ Aquilæ; β Arietis; β, η, θ Aurigæ; γ Boötis; $a, \beta, \gamma, \epsilon, \eta$ Canis Majoris; a, β Canis Minoris; β, δ, ϵ Cassiopeiæ; a Cephei; γ Ceti; a, β, γ Coronæ Borealis; γ, δ Corvi; δ Cygni; a, ϵ Delphini; a, ζ Draconis; $a, \gamma, \delta, \theta, \xi$ Geminorum; $\gamma, \delta, \epsilon, \mu$ Herculis; $a, \beta, \delta, \zeta, \eta$ Leonis; a, ϵ, ζ, η Leporis; a, β Libræ; a, γ Lyræ; a, λ, γ Ophiuchi; a, γ, ζ Pegasi; a, β, γ, δ Persei; a Piscis Australis; a Piscium; β Scorpii; ϵ, μ Serpentis; β, ξ, η Tauri, and the brighter of the Pleiades; β Trianguli; $\beta, \gamma, \delta, \epsilon, \zeta, \eta$ Ursæ Majoris; a Ursæ Minoris; a, γ, ζ, η Virginis. The following form a subdivision of Type I.:— $\beta, \gamma, \delta, \epsilon, \zeta$ and κ Orionis.

Type II.— $\beta, \gamma, \delta, \lambda, o$ Andromedæ; a, β Aquarii; β, γ, ϵ Aquilæ; a Arietis; $a, \delta, \epsilon, \zeta, \iota$ Aurigæ; $a, \beta, \delta, \epsilon, \eta, \rho$ Boötis; δ Canis Majoris; a^1, a^2 Capricorni; a, ζ, η Cassiopeiæ; $\beta, \gamma, \zeta, \eta$ Cephei; $\beta, \zeta, \eta, \theta, \iota$ Ceti; β Corvi; $a, \beta, \gamma, \epsilon, \zeta, \tau$ Cygni; β Delphini; $\beta, \gamma, \eta, \theta, \iota, \xi, \chi$ Draconis; β Geminorum; β, ζ, η, π Herculis; a, ϵ, ζ Hydræ; γ, ϵ, μ Leonis; β, γ Leporis; β, ϵ, κ Ophiuchi; ϵ, η, μ Pegasi; ϵ, ζ Persei; η Piscium; δ Scorpii; a Serpentis; $a, \gamma, \delta', \epsilon, o$ Tauri; a Trianguli; a Ursæ Majoris; β Ursæ Minoris; β, ϵ Virginis.

Type III.— λ, ϕ, χ^* Aquarii; π, ρ^* Arietis; π, v Aurigæ; v Boötis; μ^* Cephei; a, o^*, v Ceti; v^1, v^2 Coronæ Borealis; ω^3, χ^* Cygni; λ Draconis; γ^*, π Eridani; η^*, μ^* Geminorum; a^* Her-

^e *Nature*, vol. xxxvi. p. 461. Sept. 15, 1887.

^f *Companion to the Observatory*, 1888, p. 40.

culis; π , ψ Leonis; δ^{2*} Lyrae; δ^* Ophiuchi; a^* , o^* Orionis; β^* , ϕ^* Pegasi; ρ^* Persei; δ Piscium; δ^* Sagittae; a^* Scorpii; κ , τ' , Serpentis; ρ^* , μ Ursae Majoris; δ^* , ψ^* , σ Virginis; a Vulpeculae.

The finest examples of the type in the foregoing list are marked with an asterisk. The following also yield beautiful spectra:—

No.	Star.	Mag.	R.A. 1900.			Decl. 1900.	
			h.	m.	s.	°	'
1	R Andromedæ	Var.	0	18	45	+ 38	1·4
2	724 Bradley Leporis ...	6·0	5	6	42	— 11	58·3
3	119 Tauri	4·4	5	26	21	+ 18	31·2
4	51 Geminorum	5·5	7	7	38	+ 16	19·8
5	R Leonis	Var.	9	42	11	+ 11	53·6
6	40 Comæ	5·8	13	1	30	+ 23	9·3
7	R Hydræ	Var.	13	24	15	— 22	45·8
8	26918 Lal. Bootis	5·5	14	41	3	+ 15	33·1
9	342 Birm. Draconis... ..	4·5	14	56	0	+ 66	19·8
10	γ Herculis	Var.	16	25	21	+ 42	6·1
11	R Lyrae	Var.	18	52	17	+ 43	48·7
12	3 Aquarii	4·8	20	42	28	— 5	23·6
13	71 Pegasi	6·0	23	28	28	+ 21	56·9
14	30 Piscium	4·4	23	56	50	— 6	34·2

Type IV. is not represented by a single bright star, the two brightest being Nos. 4 and 6 in the list below, both of them red stars of about mag. $5\frac{1}{2}$. The following are amongst the finest specimens of the type:—

No.	Star.	Mag.	R.A. 1900.			Decl. 1900.	
			h.	m.	s.	°	'
1	96 Birm. Orionis	6·0	5	0	14	+ 1	2·4
2	2139 B. A. C Aurigæ... ..	6·3	6	29	40	+ 38	31·6
3	211 Birm. Cancrī	6·5	8	49	45	+ 17	36·7
4	3637 B. A. C. Hydræ... ..	5·4	10	32	36	— 12	51·9
5	D.M. + 68°, No. 617 Ursæ	6·2	10	38	8	+ 67	56·2
6	4287 B. A. C. Can. Venat.	5·5	12	40	26	+ 45	59·2
7	6702 B. A. C. Draconis ...	6·5	12	95	5	+ 76	21·8
8	589 Birm. Cygni	6·2	21	37	48	+ 35	3·2
9	19 Piscium	6·2	23	41	17	+ 2	56·0

Vogel divides stellar spectra into three classes^g:—Class I. Metallic lines feeble; Class II. Metallic lines prominent; Class III. Banded spectra. Each of these classes is again subdivided; Class I. into divisions *a*, *b* and *c*, according as the hydrogen lines are dark and broad, absent, or seen as bright lines. Class I *a*. therefore corresponds to Secchi's Type I. Class I *b*. appears to have been framed to meet the case of several of the brightest Orion stars, which show no strongly marked lines at all in their spectra^h. Secchi had anticipated Vogel in making these stars a subdivision of his first type. Class I *c*. contains γ Cassiopeiæ and β Lyræ, and therefore would correspond to what has sometimes been called Secchi's fifth type. Class II. is divided into two divisions; II *a*. corresponding to Secchi's Type II.; II *b*. comprising stars showing metallic lines bright. Class III. is also divided into two divisions; Secchi's IIIrd type forming III *a*., and his IVth Vogel's III *b*.

Secchi examined and classified about 500 stellar spectra, but Vogel's classification has been applied to a much greater number of stars, for Dunér and Vogel have divided the entire northern heavens between them, for the purpose of a spectroscopic survey to include all stars down to magnitude 7.5; Dunér taking the region from the N. Pole down to Decl. +40°, and Vogel from the latter point down to the equator. Vogel has already published part of his investigations, the zone from Decl. +20° to Decl. -1°; and Konkoly, who has carried on the survey South of the equator, has published a similar catalogue from 0° to Decl. -15°. Vogel's catalogue contains 4051 stars; Konkoly's 2022, which totals are distributed in the following proportions amongst the different classesⁱ:—

I <i>a</i> .	I <i>b</i> .	II <i>a</i> .	III <i>a</i> .	III <i>b</i> .	Uncertain.	Total
3145	14	2105	375	12	422	6073.

^g *Ast. Nach.*, vol. lxxxiv. No. 2000. June 30, 1874.

^h Vogel however appears distinctly in error when he asserts that the hydrogen lines are wanting in β , γ , δ and ϵ Orionis, for Huggins has photographed the violet line in the spectrum of β Orionis, and Maunder has often measured the F line

in all the four. Konkoly however asserts that these spectra are variable. See *Observatory*, vol. viii. p. 385, Nov. 1885; and *O'Gyalla Beobachtungen*, vol. viii. part 2, p. 8.

ⁱ *Publ. des Astroph. Obs. zu Potsdam*, vol. iii. No. 11, and *O'Gyalla Beobachtungen*, vol. viii. part 2.

Vogel's classification has been much criticised on the ground that it assumes on insufficient evidence that the first class are the hottest stars and therefore the youngest in development, that the second class represent stars which have already passed through the first stage and are cooling down, and that the third have cooled down further still. And it is further objected that this classification does not recognise growing stars, only decaying ones. Lastly, the grouping of Secchi's IIIrd and IVth types under one head seems quite inadmissible; for the two types seem the most strongly contrasted and clearly distinguished of any, and whilst many examples are found intermediate between Secchi's Ist and IInd types or between his IInd and IIIrd, his IIIrd and IVth are linked by no such transitional spectra. Indeed as the bands are shaded in different directions in the two types, and as the darkest band of the one type corresponds very nearly to the brightest interspace (or "zone," to adopt Dunér's convenient nomenclature) of the other, and *vice versa*, it is scarcely possible that such intermediate forms should exist, or if existing should be recognised as such. Nor does Vogel's suggestion that the IIIrd and IVth types may represent alternative stages of cooling, some stars displaying the one spectrum and others the second at a particular epoch, fare much better. For no really distinct example of a spectrum intermediate between the IInd and IVth types has yet been recorded^k; a circumstance which is however as damaging to Lockyer's scheme as to Vogel's.

Still Lockyer's classification takes full cognizance of all the objections to Vogel's except the last. As has been already stated in noticing Lockyer's work on the spectra of meteorites, his theory is "that all the bodies in the universe are or have been swarms of meteorites, the present differences between them depending upon differences of temperature (the heat being brought about by collisions due to gravity), and the differences in the distances apart of the constituent meteorites^l." He

^k Pechüle, *Expédition Danoise pour l'Observation du passage de Vénus*, 1882, p. 25.

^l *Month. Not.*, vol. xlix. p. 222. Feb. 1889.

therefore includes not merely stars properly so called within the scope of his classification, but every other variety of celestial body as well, for it is a fundamental proposition with him that "the existing distinction between stars, comets and nebulæ rests on no physical basis," but that all are alike meteoritic in origin. His scheme involves 7 groups, the first 3 representing increasing temperature, the 4th maximum temperature, and the last 3 temperature decreasing^m.

Group I. The spectrum is one in which bright lines and flutings are the predominant feature. Nebulæ, comets near aphelion, and stars with bright lines in their spectra are included in this group.

Group II. corresponds practically to Secchi's IIIrd type, but includes also some comets near perihelion. For Lockyer regards the spectra of this type as of a very composite construction, and as partly due in its "zones" or bright interspaces to the presence of the bright carbon bands so characteristic of cometary spectra, and he therefore brackets these stars, which he considers as no true stars but rather as somewhat condensed meteor-streams, with comets, as resembling them both in spectrum and in composition. It should however be said that his identification of the zones of Secchi's IIIrd type with the bright hydro-carbon bands has not been generally received. Huggins gave the point the most careful consideration long ago, and decided against Lockyer's present view; and though Copeland considered he had shown the presence of carbon in the spectrum of *Nova Orionis*, his inference was promptly challenged by Maunderⁿ. Lockyer's explanation of the absorption bands, though most ingenious, is far from satisfying. His method, however, of grouping the stars of this type into 15 species according to the number and intensity of the shaded bands which they display appears likely to be of service, and the discovery of bright lines in one member after another of one particular group (No. 10) seems to show that this classification is not an arbitrary one.

^m "Bakerian Lecture," *Proc. Royal Soc.*, vol. xlv. pp. 23-27. April 12, 1888.

ⁿ *Month. Not.*, vol. xlvi. pp. 112 and 284. Jan. and March 1886.

Group III. corresponds to some of the spectra of Secchi's IInd type, Group V. to the remaining members of that type; the former being associated with increasing temperature, the latter with decreasing. The discrimination between the two groups of spectra so closely resembling each other is a very delicate task, and can hardly be regarded as satisfactorily accomplished as yet. Lockyer suggests as criteria of a spectrum of Group III. the presence of a pair of lines at wave length 540 and ascribed to manganese, an iron line at 579, and a line at 568 supposed to be due to sodium. A fourth line at 499 seems also characteristic of this group °.

Group IV. corresponds to Secchi's Ist type; Group VI. to Secchi's IVth, whilst Group VII represents the cold and dark stage as seen in planets.

The relationship between the 3 modes of classification may be shown as follows:—

Secchi.	=	Vogel.	=	Lockyer.
Type I.	=	Class I <i>a.</i>	=	Group IV.
Type II.	=	Class II <i>a.</i>	=	{ Group III. and Group V.
Type III.	=	Class III <i>a.</i>	=	
Type IV.	=	Class III <i>b.</i>	=	Group VI.
Type V.	=	{ Class I <i>c.</i> and Class II <i>b.</i>	=	Group I.

It is clear therefore that for most purposes Secchi's types are still quite sufficient; but as the spectrum catalogues of Dunér, Vogel and Konkoly are based on Vogel's scheme, and as Lockyer's wide-reaching meteoric hypothesis is so intimately connected with his classification, it is important that the lines upon which each division has proceeded should be borne in mind.

Whilst the spectra of Secchi's Ist and IInd types indicate that the stars resemble our Sun in the possession of a glowing photosphere surrounded by absorbing vapours in which many elements known to us play an important part, there are not wanting spectra which seem to carry on the analogy and to

hint at stellar chromospheres and prominences. The 3 stars γ Cassiopeiæ, β Lyræ, and η Argûs are of this order, showing as they do not only the hydrogen lines C and F as bright, but also the "helium" line D_3 , a line otherwise only known to us in the solar chromosphere. Stars in which the chromosphere and its extensions so preponderate must of course differ very widely in their condition from our Sun, but the great principle we see so widely exemplified in Nature, of unity of plan with diversity of detail, would lead us to expect to find a few instances in which the stellar chromosphere was sufficiently pronounced to make its presence known to us. That these 3 bodies are unlike our Sun in some important features is clear from all three being variable; η Argûs most remarkably so. The bright lines in their spectra are variable likewise. In the case of β Lyræ, De Gothard finds the variation to be probably periodic, and to occupy about 7 days^p; in that of γ Cassiopeiæ, the same observer lost the C line for 9 years, viz. from 1874 to 1883. The F line was however frequently observed during this time by the observers at Greenwich, and the C line was observed in 1879 by Copeland at Dun Echt, for it is a further peculiarity of both β Lyræ and γ Cassiopeiæ that their bright lines do not vary simultaneously; β Lyræ indeed, according to Maunder^q, usually shows D_3 as its most prominent line, but either C or F may be the brightest line in γ Cassiopeiæ.

These 3 stars are far from being the only ones which show or have shown bright lines. No fewer than 28 have been discovered already, and the number is continually being added to. Of one class of these, the first members known were the 3 stars discovered by Wolf and Rayet in Cygnus^r. The most developed of these shows 5 bright lines, one of which is the F line of hydrogen. The origin of the other 4 lines is uncertain. The line usually most conspicuous lies in the blue, and is broad and diffused, with its maximum about λ 468.

^p *Ast. Nach.*, vol. cvi. No. 2539, Sept. 14, 1883; vol. cviii. No. 2581, March 31, 1884.

March 1889.

^q *Month. Not.*, vol. xlix. p. 300.

^r *Comptes Rendus*, vol. lxxv. p. 292. Aug. 12, 1867.

Lockyer ascribes it to the blue band of the carbon spectrum. The other 3 lines at λ 581, 570, and 540 he assigns to manganese, sodium, and iron respectively. Vogel in the light curves which he supplies for 5 of these stars gives indications of other lines, at wave-lengths about λ 507, 527, 558 and 636^s. The element causing this last line has not yet been identified, but Lockyer considers that he has recognised the line itself in the spectrum of the Limerick meteorite when heated in the oxyhydrogen flame.

The stars of this class are:—

No.	Star.	Mag.	R.A. 1890.			Decl. 1890.	Lines seen.
			h.	m.	s.		
1	13412 Lal. Canis Maj.	7.6	6	49	33	- 23 47.3	λ 540, F.
2	γ Argûs	2½	8	5	56	- 46 59.5	D line of Sodium.
3	9168 Stone Scorpii ...	6½	16	46	36	- 41 38.2	
4	Ölt. Arg. 17681 ...	8.0	18	1	46	- 21 16.2	λ 540.
5	D.M. + 35°. No. 3952	7.5	20	1	43	+ 35 21.6	
6	D.M. + 35°. No. 4001	8.5	20	6	4	+ 35 51.1	λ 540, F.
7	D.M. + 35°. No. 4013	8.0	20	7	42	+ 35 51.1	λ 540.
8	D.M. + 37°. No. 3821	7.1	20	8	6	+ 38 1.5	
9	D.M. + 36°. No. 3956	8.0	20	11	25	+ 36 19.5	λ 540.
10	P Cygni	Var.	20	13	44	+ 37 41.4	F.

All the above appear to show the lines λ 581 and 468; and all but Nos. 1 and 4 to show λ 570. When λ 540 and F have been seen the circumstance is noted in the last column.

A very remarkable spectrum is given by R Geminorum, 10 bright lines having been recorded by Vogel in its spectrum^t. Vogel regards it as a reversal of the IVth type spectrum; 3 of the lines clearly appear to correspond with the hydrocarbon bands, whilst a fourth, and the brightest, is λ 581, the typical line of the preceding class.

The 4 following stars were discovered by Copeland whilst on an astronomical expedition to South America^u. They show 2

^s *Publ. des Astroph. Obs. zu Potsdam*, vol. ii. part 1.

^t *Ast. Nach.*, vol. lxxxiv. No. 2000. June 30, 1874.

^u *Copernicus*, vol. iii. p. 207.

bright lines recorded, in the 3rd and 4th stars, as at λ 5753 and λ 4636 respectively. These 2 bright lines are as yet unexplained. The stars are:—

No.	Star.	Mag.	R.A. 1890.			Decl. 1890.	
			h.	m.	s.	°	'
1	— Argûs ...	8.8	8	51	19	—47	10.0
2	— Argûs ...	9.8	10	37	15	—58	10.8
3	Gould 15305	9.0	11	5	25	—60	22.9
4	— Centauri	9.0	13	11	3	—57	33.2

But the most interesting of all the bright-line stars have been the 3 new stars which appeared in 1866, 1876, and 1885 respectively. On May 12, 1866, a faint 9th magnitude star in the Northern Crown, and since generally known as T Coronæ,

Fig. 163.



SPECTRUM OF T CORONÆ.

suddenly attained a brightness surpassing that of a 2nd magnitude star, and then rapidly faded away till it again became of the 9th magnitude by the end of the month. On the 16th of May, when it was of about the 4th magnitude, Huggins examined its spectrum, and found that in addition to a spectrum apparently of Secchi's IIIrd type, it showed 4 bright lines, 2 of which were due to hydrogen. Their great brightness showed that the luminous gas was hotter than the photosphere ^v.

The instantaneousness of the outburst in this and the other Novæ, and the rapidity with which the light diminished afterwards, is the most convincing proof that they are bodies wholly unlike our Sun. It is impossible to conceive that the Sun

^v *Proc. Roy. Soc.*, vol. xv. p. 146. May 17, 1866.

could suddenly develop 2000 times its usual light and heat as T Coronæ did, or if it did so increase in temperature that it could return to its normal condition in a few weeks. Only a small body, or a collection of small bodies, could so behave. But that T Coronæ was not in the aggregate a small body is clear from its appearing so bright despite its enormous distance, a distance so great that the star gave no appreciable parallax. We are driven then to the conclusion that this and other similar temporary stars are vast collections of small separate bodies, or in other words, swarms of meteors.

This inference arrived at by Lockyer many years ago has in his hands assumed a very far-reaching importance, and recent events have greatly aided in its development. In 1876 another "temporary" star appeared in the constellation of the Swan. It was discovered on Nov. 24 by Schmidt, who estimated it as nearly of the 3rd magnitude, and a few days later its spectrum was examined by Cornu at Paris, and by Vogel and Lohse at Potsdam. Cornu's report upon it was to the effect that it showed not only the red, blue, and violet lines of hydrogen, but also the helium line D₃, a line near the coronal line 1474 K, and two other lines frequently seen in the spectrum of the solar chromosphere; that in fact it was distinctly a chromospheric spectrum^x. Copeland's observations did not perfectly agree with Cornu's, but both agreed as to the presence of the hydrogen lines, and of a line of wave-length about λ 500 which was destined to become very important. Vogel also observed the same lines, together with the lines λ 581 and λ 467 characteristic of γ Argûs and similar stars. But the significant feature was that which was to come. As the star faded, the continuous spectrum died away, and the hydrogen lines and that at λ 500 became more conspicuous, and at last, on Sept. 2, 1877, the star showed only this one line, the line at λ 500, the line typical of a gaseous nebula. So far as the record of the spectroscope went, the star had ceased to be a star and had become a nebula^y. This state of affairs did

^x *Comptes Rendus*, vol. lxxxiii. p. 1172. Dec. 11, 1876.

^y *Copernicus*, vol. ii. p. 101.

not however continue long, for in 1880 Pickering found the bright line had faded, and a very faint continuous spectrum, as from an ordinary star, remained^z.

The connection between nebulæ and "temporary" stars thus hinted at by the changes of the spectrum of Nova Cygni had been suggested by several circumstances,—such as the appearance of the new star in 80 M Capricorni in 1860, and the remarkable variations of η Argûs in the nebula called after it,—but was to receive a more striking confirmation still. In August 1885 a new star was discovered almost in the centre of the great nebula in Andromeda. It seems to have attained its greatest brilliancy about Sept. 1, when it was of magnitude 6.5, and faded somewhat slowly but steadily during the following days. Its spectrum proved a difficult object, partly owing to the faintness of the star, but perhaps principally to the fact that it was involved in the nebula. Like that of the nebula, the spectrum of the Nova was continuous with a defect of light in the red and yellow. But opinions were much divided as to the details of the spectrum; on the whole it appears that there were several bright points, either true bright lines, or intervals between absorption bands, between D and *b*. Maunder gives 3 lines, λ 5575, λ 5482 and λ 5327, which might well correspond to the three principal coronal lines^a; Copeland also gives three, λ 5468, λ 5140 and λ 4892; whilst on another occasion he saw two nearer to the blue, λ 4822 and λ 4716. Copeland's suggestion, made independently also by Konkoly, that the spectrum was really a fluted one, either of Secchi's IIIrd or IVth type, is a very reasonable one, particularly when it is borne in mind that the ground-work of the spectrum of T Coronæ was of Secchi's IIIrd type.

The probability of this being the true solution is increased when it is borne in mind that a very large proportion of our variable stars have spectra of this type. Whilst the proportion of known or suspected Variables in the northern heavens is, speaking

^z *Harvard College Report*, 1880, p. 7.

^a *Month. Not.*, vol. xlvi. p. 19. Nov. 1885.

roughly, 1 in 659, the variables of Type III. are 1 in 7, and of Lockyer's Species 10; that is, of the most developed examples of the type, more than one-half are very widely variable. The connection between variation and this form of spectrum is therefore most manifest.

It is plain, too, that many of these variables must be wholly different bodies from our Sun. The extreme variations of Mira Ceti are as great as those of T Coronæ, and by a similar mode of reasoning we are brought to conclude that that star with a beautiful spectrum is also not one vast globe, but a number of small bodies; a swarm or several swarms of meteors. The resemblance between Mira Ceti and T Coronæ has been carried further by the

Fig. 164.

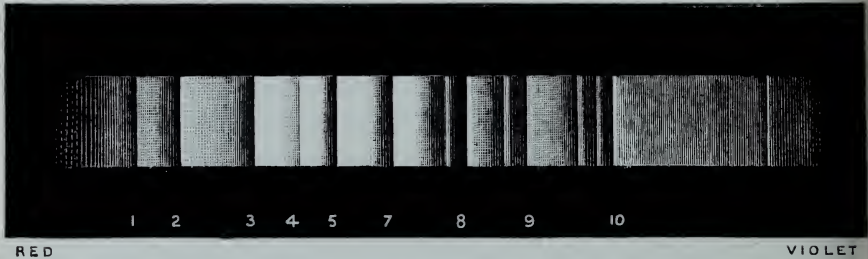

SPECTRUM OF MIRA CETI.

* * * The numbers refer to Duncr's Bands.

discovery of the bright lines of hydrogen in its spectrum. This discovery was effected at Harvard College by means of photography^b. The same lines were also photographed as bright in Gore's new variable in Orion, another strongly marked star of Type III. Espin and Maunder have since seen the *G* line bright in Mira, and Espin has observed one or other line of hydrogen bright in R Cygni, R Leonis, and R Hydræ, probably also in χ Cygni; all variables of great range and long period, and all with strongly-marked spectra of Type III.

The connection between "temporary" stars and long-period variables is therefore now established, and the reasons are strong for thinking that both are aggregations of small bodies, rather than true suns. Monck ascribes the outburst of light in

^b *First Ann. Rep. of H. Draper Memorial*, p. 6.

the one class and the variation in the other to the passage of a meteor-swarm through a nebula; a suggestion that meets the facts of the case very well. Lockyer prefers to ascribe the changes to collision of meteor with meteor and stream with stream. The case of Nova Andromedæ furnishes an argument for the latter of the two alternatives; for it may be urged that the continuous character of the spectrum of the nebula, and the impossibility of resolving it, all point to its being not a gaseous nebula, but a vast collection of small bodies, or as Sir John Herschel suggested long ago, "the great nebula in Andromeda may be and not improbably is optically nebulous owing to the *smallness* of its constituent stars."

TABLE OF NEBULÆ GIVING SPECTRA OF BRIGHT LINES.

Number in Sir J. Herschel's Catalogue.	Other Designation.	Number in Sir J. Herschel's Catalogue.	Other Designation.
385	76 M	4066	3594 h.
386	193 H I.	4234	5 Σ.
1179	Great Neb. in Orion.	4361	8 M.
1225	34 H IV.	4373	37 H IV.
1269	2941 h.	4390	6 Σ.
1532	45 H IV.	4403	17 M.
1567	64 H IV.	4447	57 M.
1783	3189 h.	4499	38 H VI.
1843	3163 h.	4510	51 H IV.
2017	3228 h.	4514	73 H IV.
2076	3242 h.	4532	27 M.
2102	27 H IV.	4572	16 H IV.
2197	3295 h (η Argûs).	4627	192 H I.
2343	97 M.	4628	1 H IV.
2581	3365 h.	4827	705 H II.
2917	65 H I.	4964	18 H IV.

The record of the spectroscope with regard to nebulæ has been as full of interest as that which it has given of the various orders of stars. The very first observation made on a nebula was recognised at once as of great importance. For when in August 1864 Huggins commenced the examination of these bodies by turning his spectroscope on the small but bright nebula which

marks the pole of the ecliptic, he found no trace of the rainbow-tinted band that stars give, but in place of this, 3 bright lines only, and he saw that he had before his eyes a true nebula; not a star cluster apparently nebulous because of its distance. The bright lines could only be due to luminous gas. One of the lines, the faintest, was coincident with F; the brightest with one of the close pair of green lines of nitrogen; whilst the third has not been found to coincide with any strong line of any known element. Huggins felt at once the importance of examining as many nebulae as possible, and he eventually found the nebulae enumerated in the Table on p. 369 to be probably gaseous in constitution^c.

Many nebulae give a faint continuous spectrum besides that of the bright lines, and of the bright lines different nebulae by no means all show the same number. In the brighter nebulae a fourth line still more refrangible is seen, which coincides with the bright hydrogen line *G*; and in the spectrum of the great nebula in Orion Taylor has been able to recognise no fewer than 9 lines, viz. the 4 ordinary nebular lines, *D*₃, and lines at wave-lengths $\lambda 5592$, $\lambda 5200$, $\lambda 4703$ and $\lambda 4470$ respectively. Previous to this observation 7 was the greatest number that had been seen in any nebula, and of these 3 were undoubtedly due to hydrogen. The brightest line was coincident, as has been already stated, with one member of the brightest pair of nitrogen lines. This of course was not sufficient to prove that the line was really due to nitrogen, though it has often been spoken of as the nitrogen line, and Lockyer has now explained, not this line only, but two others as well, to be due to magnesium. The next brightest line in the typical nebular spectrum, the one shown in the accompanying diagram as the central of the 3 lines, has not yet been assigned to any element, but Lockyer believes that he has recorded it in the spectrum from the glow of the Dhurmsala meteorite. Liveing and Dewar have however disputed the correctness of Lockyer's opinion that the magnesium fluting at 5006.5 indicates a lower temperature than do the *b* lines of the same metal. Moreover, Huggins finds that the brightest nebular

^c *Phil. Trans.*, vol. cliv. p. 437, 1864; vol. clviii. p. 540. 1868.

line lies distinctly within the fluting, about 2 tenth-metres from its sharp edge, but that it is in almost precise coincidence with the nitrogen line; as to the other lines also, he fails to find any evidence of magnesium in the nebular spectrum, and considers it certain that Lockyer is mistaken in his identification ^d.

The line known as the “nitrogen” line is the typical nebular line, being seen in those spectra which show no other. The line which Lockyer recognises in the spectrum of the Dhurmsala meteorite is seen next in frequency; then the F line. But one or two spectra are known which give for their fourth line, not G, but λ 4694. Whether this is the broad band at λ 468 so frequently noted in the spectra of bright-line stars, or the line λ 4703 recorded by Taylor in the Orion nebula, is not yet ascertained.

Fig. 165.

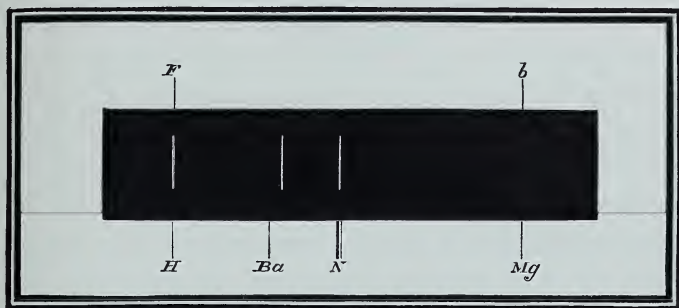

SPECTRUM OF THE NEBULA 37 μ IV. DRACONIS.

The present Earl of Rosse has compared the observations made with his father’s great telescope of the nebulæ and clusters examined by Huggins, in order to inquire how far the classifications of the telescope and spectroscope agreed. The result is:—

	Continuous spectrum.	Gaseous spectrum.
Clusters	10	0
Resolved, or resolved?	5	0
Resolvable, or resolvable?	10	6
Blue or green, no resolvability	} 0	4
No resolvability seen		6
	—	—
	31	15
Not observed by Lord Rosse	10	4
	—	—
	41	19°

^d *Proc. Roy. Soc.*, vol. xlv. p. 245, May 31, 1888; vol. xlvi. p. 40, May 2, 1889

^e *Brit. Assoc. Rep.*, 1868, p. 149.

Considering the extreme difficulty of telescopic observation of these objects, these results are remarkably accordant, and it was therefore at one time assumed that those nebulae which give a continuous spectrum are clusters of actual stars, while those which give only bright lines must be considered as simply masses of luminous gas. According to Lockyer's theory the difference is one rather of condensation than of constitution; the meteorites in nebulae giving a bright-line spectrum are widely separated, their collisions few, and their temperature comparatively low; whilst in those giving a continuous spectrum the aggregation of the meteorites is much further advanced, their collisions more frequent, and the temperature higher.

An exceedingly interesting investigation has been undertaken by Huggins, namely, the determination of the velocity of movement in the line of sight of the brightest stars, from the displacement of certain lines. For this, a very considerable dispersion is required, and hence in order that the spectrum may not be too much weakened, a telescope with a very large object-glass is needed, to collect sufficient light. In Secchi's work on star-types a slit might be dispensed with, as the image of the star formed by the cylindrical lens is almost a mathematical line; but in this a narrow slit is of primary importance, for otherwise the star might shift its position, and therefore the whole spectrum, including the particular line under examination, would likewise move in one direction or the other. A similar fictitious appearance of displacement will be caused if the light from the terrestrial substance which gives the comparison spectrum does not enter the slit perfectly at right angles to it. An additional difficulty is afforded in the case of stars of the Ist type by the breadth of the absorption lines in the star spectrum and the shaded appearance of their edges.

Fig. 166 shows the relative positions and appearances of the F line in Sirius and the hydrogen line $H\beta$ given by a vacuum tube.

The 12-inch equatorial of the Greenwich Observatory has been devoted during the last few years to the same inquiry, and

many observations have also been made by Seabroke at the Temple Observatory, with results agreeing fully as closely with those of Huggins as could have been anticipated, when the

Fig. 166.

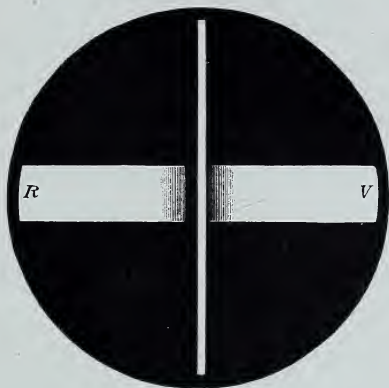

LINE F IN SPECTRUM OF SIRIUS COMPARED WITH HYDROGEN.
DECEMBER, 1875.

exceedingly difficult and delicate nature of the work is borne in mind, as the accompanying table will show.

MOTIONS OF STARS IN THE LINE OF SIGHT IN MILES PER SECOND AS OBSERVED BY HUGGINS, AT GREENWICH, AND AT RUGBY.

(+ denotes recession, - approach.)

Star.	Huggins [†] .	Greenwich.	Rugby [‡] .
α Andromedæ	-	-28	-25
γ Pegasi... ..	-	-22	-22
γ Cassiopeiæ	+	-12	...
Aldebaran	+	+31	...
Capella	+	+23	+3
Rigel	+15	+18	...
α Orionis	+22	+28	...
γ Geminorum	-29	-46
Castor	+26	+10	+20
Procyon	+	+3	+11
Pollux	-49	-33	-34
Regulus	+15	+6	+21
γ Leonis... ..	-	-22	-3
δ Leonis... ..	+	-19	-14

[†] *Proc. Roy. Soc.*, vol. xx. p. 379. June 6, 1872.

[‡] *Month. Not.*, vol. xlvii. p. 93. Jan. 1887.

Star.	Huggins.	Greenwich.	Rugby.
θ Leonis...	...	+ 6	+ 21
β Leonis...	...	- 7	- 2
Spica	- 17	+ 16
η Boötis	- 34	- 9
Arcturus	- 55	- 19
ϵ Boötis	- 9	- 19
α Coronæ	+ 17	- 25
α Ophiuchi	- 13	- 21
Vega	- 49	- 45
γ Lyræ	- 21	- 31
ζ Aquilæ	- 27	- 45
γ Aquilæ	- 29	- 9
δ Cygni	- 18	- 20
Altair	- 27	- 18
γ Cygni	- 14	- 40
α Cygni	- 39	- 16
ϵ Cygni	+ 1	- 42
η Pegasi...	...	- 11	- 54
β Pegasi...	...	- 8	+ 2
α Pegasi...	...	- 23	- 29

It will be observed that there are only 7 cases of discordance of sign out of the above 34 stars, and that in many of the brighter stars there is also a fair agreement as to the rapidity of the movement. There are 8 other stars however which have been observed at the 3 observatories for which the results obtained are decidedly discordant. Of these 7 are the stars of the "Plough," the 7 brightest stars of Ursa Major. The Greenwich results agree fairly well with those of Huggins, but Seabroke's are very discordant. The reason of this difference lies probably in the fact that from the position of these stars they were observed with great difficulty at all of the observatories, and most especially so at that of Rugby.

The case of the 8th star on the list, Sirius, is very different and opens out some interesting questions. The observations made at Greenwich in 1875 and 1876 were closely confirmatory of the results obtained by Huggins in 1872 and show a motion of recession of about 21 miles per second. But year after year there was a distinct tendency to lessen this amount, until in 1883 it disappeared, and a small motion of approach was shown; and though there were wide discordances between the observa-

tions obtained on different nights, yet the mean of each year's observations has shown a steady progress from 1875 to the present time, so that the once large motion of recession would appear to have changed into a still larger motion of approach. The results obtained by Seabroke in 1886 and 1887 fully confirm those secured at Greenwich at the same time, and point to a motion of approach of about 30 miles per second. But Huggins and Vogel have recently been trying to photograph the displacement of stellar lines, and the latter finds the earlier measures confirmed by the photographs obtained at the present time, and that Sirius is still receding.

The accompanying diagram will explain how readily so serious a divergency may arise. The spectrum of Sirius is bright enough

Fig. 167.

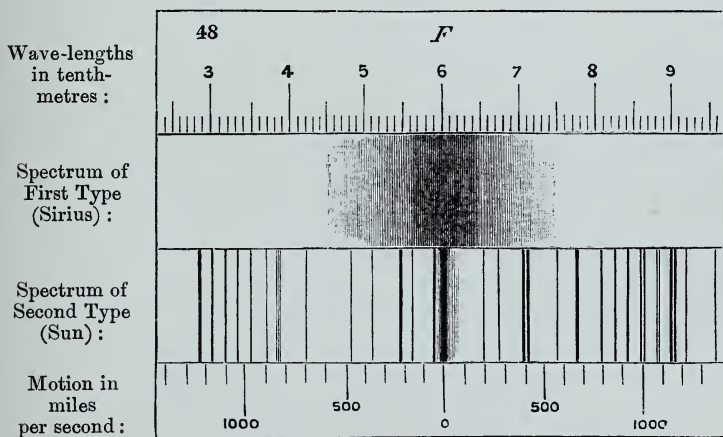
REGION NEAR *F* IN SPECTRA OF THE 1st AND 2nd TYPES.

to bear a high dispersion: there is no difficulty on that score, but it is low down in the sky and seldom seen steadily, whilst the lines in its spectrum are exceedingly wide and ill-defined. The uncertainty therefore as to the centre of the line bears a very high ratio to the possible displacement in either direction, and personality in bisection would well explain even larger discordances between different observers than have actually been observed.

Probably the discordances in the measures of displacement of lines in spectra of the Ist type are almost wholly due to the broad ill-defined character of the lines; whilst the narrowness of those in the IInd type renders them far harder to hold steadily, and opens up special difficulties of a different order.

For 4 other stars Vogel's photographs give the following results as compared with those obtained at Greenwich and Rugby:—

Star.	Motion per second, in miles.		
	Vogel.	Greenwich.	Rugby.
α Persei ...	- 7	- 22	...
Aldebaran ...	+ 30	+ 31	...
Capella ...	+ 16	+ 23	+ 3
Procyon ...	- 7	+ 3	+ 11

The diagram on p. 377 shows the distribution of the stars observed at Greenwich for motion in the line of sight. The observations, even if they were more accordant *inter se*, are not sufficient in number nor widely and evenly enough distributed to throw much light on the problem of the motion of the solar system in space. The following results, obtained by Hofmann^h from the discussion of the 3 series of observations, may be interesting, and they serve to show how far from precision any such inquiry is at present, though if a fair number of the giant telescopes now erected or being erected in different parts of the world were to be devoted to the work, it would not fail soon to yield a plentiful and satisfactory harvest.

	Velocity of Translation. Miles per second.	Apex of Solar Motion.	
		R.A.	Decl.
Huggins ...	30.1 \pm 14.4	309.5	+ 69.7
Greenwich ...	24.4 \pm 2.7	320.1	+ 41.2
Rugby ...	15.2 \pm 9.8	278.8	+ 13.6

One other star, which has been observed by means of the spectroscope at Greenwich for motion, deserves some mention. This is Algol, the well-known variable. Pickering has supported the view first suggested a century ago by Goodricke (who discovered the variability of this star) that the variations in its light might be due to a large satellite which by transiting it periodically

^h *Ast. Nach.*, vol. cxiv. No. 2714. Feb. 27, 1886.

occasioned a partial eclipse. Pickering has further pointed out that in this case Algol would have a rapid motion round the centre of gravity of the system, and would sometimes therefore be approaching us very rapidly; at other times receding as fast. The results obtained as yet at Greenwich for the motion of this star often show great discordances, due no doubt to

Fig. 168.

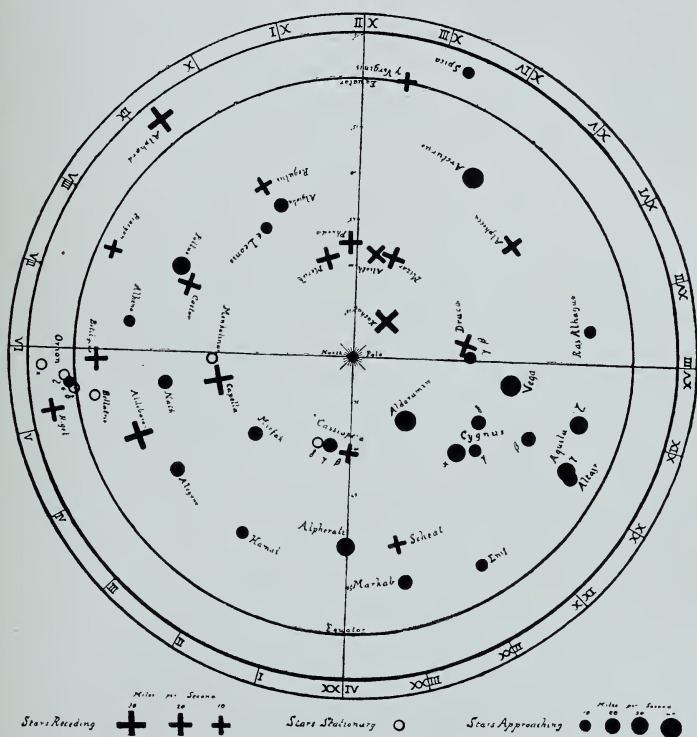

CHART SHOWING DISTRIBUTION OF STARS OBSERVED FOR MOTION IN THE LINE OF SIGHT.

the diffuse character of the line observed, for the star is of the Sirius type, but on the whole there seems some distinct evidence that the satellite theory is the true one. The observations have been grouped into 4 sections; those taken about 17 hours after minimum, when the orbital motion of Algol would be one of rapid approach; those taken 17 hours before, when it would

be one of recession; and those taken either near minimum, or 34 hours after, when the effect of the orbital motion would be small. The result is given below:—

	Interval from minimum in terms of Period.	No. of Nights.	Mean Motion in Miles per sec.
Inferior Conjunction	0.028	5	-12.1
First Elongation ...	0.247	10	-63.0
Superior Conjunction	0.497	10	-15.8
Second Elongation ...	0.770	11	-21.4

It would appear therefore that the system of Algol as a whole is approaching the earth; but that its motion of approach is much more rapid 17 hours after minimum than at other times, a circumstance well in accordance with Pickering's suggestion.

CHAPTER V.

MAPS OF THE SPECTRUM.

Kirchhoff's Map of the Solar Spectrum.—Advantages of a diffraction grating.—Ångström's Normal Spectrum.—Wave-lengths of the principal Fraunhofer lines.—Reduction of Measures.—Maps of the Spectrum.—Rowland's Photographs.—The Ultra-violet Spectrum.—Huggins's photographs of Stellar Spectra, and of the Spectra of Nebulæ and Comets.—Fluorescence.—The Infra-red Spectrum.—Phosphorescence.—Abney's Photographs of the Infra-red.—Langley's Bolometer.—Entire range of the Spectrum.

ONE of the most important duties devolving on spectroscopists has been the construction of accurate maps; a work as necessary in this field of science as the construction of star charts is to an astronomer. The first great map of the solar spectrum was that constructed by Kirchhoff and Bunsen, and completed later by Hofmann. Four flint prisms, one with an angle of 60° , the other three with angles of 45° , formed the dispersing train, but these were not connected, as in modern spectroscopes, so as to secure that the ray under observation should pass through each at minimum deviation, but each required to be separately adjusted for every fresh part of the spectrum examined^a. Despite this drawback, the map was a most beautiful and accurate one, and even to the present day solar lines are often referred to by their numbers on Kirchhoff's

^a See p. 704 of the 3rd edition of this work.

scale. The map not only shows the solar spectrum, but along its lower edge are given the positions of the lines of a number of different terrestrial elements for comparison.

Kirchhoff's map labours however under one great disadvantage. The relative positions of the lines shown in it are not directly comparable with those of the same lines as shown in other spectroscopes. This arises from the circumstance that with different spectroscopes the distances between individual lines do not always change in the same proportion as the entire length of the spectrum. Thus if 2 prisms similar in shape and size, one of flint glass and one of crown, be compared, not only will the spectrum given by the first be much the longer—about double in fact that given by the other—but it will be *proportionately* more spread out in the violet than that given by the crown glass.

Though the prismatic spectrum suffers from this inconvenience, there is another method of producing a spectrum which is free from it. If the light from the slit pass through a diffraction grating, that is, a piece of glass ruled with very fine close lines, instead of through a prism, a spectrum is produced in which the distance between any 2 lines is proportional to the difference of the corresponding wave-lengths of light. In a more usual form of grating the lines are ruled upon a piece of speculum metal, the light being reflected from the face of the grating instead of passing through it. The production of a perfect grating is a work of much trouble and expense, for not merely have thousands of lines to be ruled truly parallel to each other within the space of a single inch, but it is essential for good definition that the lines be all equidistant, and all of the same breadth and depth. The maker of the earlier gratings was Nobert, but he has since been surpassed by Rutherford and Rowland, the latter of whom rules not flat gratings only but concave as well, the latter form having the great advantage for some kinds of enquiry that both collimator and viewing telescope can be dispensed with, and the spectroscope therefore is reduced to its simplest and most effective form.

Kirchhoff's map of the solar spectrum was followed shortly by one which, though inferior to it in the number of lines displayed and in delicacy of detail, had this incomparable advantage, that it was a *normal* spectrum,—the distances between different lines was proportional to the differences of their wave-lengths. This was due to Ångström and Thalén, who determined the wave-lengths of a number of the more prominent Fraunhofer lines with the greatest care, and the values they obtained have been in constant use as standards amongst spectroscopists to the present time. For the determination of the wave-length of a spectral line is equivalent to the determination of the Right Ascension and Declination of a star; it fixes its place; and given a number of standard lines in the one case, and of standard stars in the other, it becomes a comparatively easy matter to determine the places of other lines or other stars by reference to them. Tables of wave-lengths therefore are the analogues of stellar catalogues, and many spectroscopists have given attention to their formation. Fraunhofer himself determined the wave-lengths of several leading lines with marvellous skill and success, and he was followed in more recent times by Ditscheiner, Der Willigen, Mascart, and Bernard, as well as by Ångström. The last-named however of these was the most accurate worker, though even his results have been surpassed, for Müller and Kempf at Potsdam, and more recently Rowland at the John Hopkins University, U.S., have produced tables of wave-lengths considerably more exact. These are all expressed in *tenth-metres*, a tenth-metre being the $1-10^{10}$ of a metre. This unit, or one ten times as large, the millionth of a millimetre, are now all but universally employed. Professor Piazzzi Smyth has however pleaded eloquently for tables of *wave-frequencies*, the reciprocals that is of wave-lengths, and for taking the British inch as the standard of length instead of the metre. The following table gives for the principal Fraunhofer lines the wave-lengths expressed in tenth-metres as given by Ångström, Müller and Rowland respectively, with, in the last column, the number of waves to the British inch as preferred by Professor Smyth.

Line.	Ångström ^b .	Müller ^c .	Rowland ^d .	Smyth ^e .
A (edge) ...	7597.5	7593.97	33440
a	7287.59	35350
B (edge) ...	6867.10	6868.53	6867.38	36988
C... ..	6562.10	6563.14	6562.96	38707
a	6277.09	6277.95	6278.22	40462
D ₁	5895.13	5896.25	5896.08	43086
D ₂	5889.12	5890.23	5890.12	43130
Peirce's line ^f	5623.36	5624.75	5624.70	45170
Coronal line	5317.01	5316.80	47779
E ₁	5269.59	5270.55	5270.43	48200
E ₂	5268.67	5269.90	5269.65	48210
b ₁	5183.10	5183.93	5183.73	49005
b ₂	5172.16	5172.84	5172.80	49108
b ₃	5168.48	5169.09	49142
b ₄	5166.88	5167.67	5167.50	49159
c	4956.87	4957.70	51242
F... ..	4860.74	4861.64	4861.43	52255
e	4404.26	4405.00	57675
f	4382.82	4383.70	57954
G ^g	4340.10	4340.71	58525
G... ..	4307.25	4308.25	4307.96	58967
g	4226.36	4227.08	60100
h	4101.2	4101.98	61933
H	3968.1	3968.79	64012
K	3933.0	64582

Ångström's values have since been corrected by Thalén for the error of the metre employed by him in their determination. It appears that his results need to be multiplied by a factor, the logarithm of which is 0.0000556^h. The wave-length of the mean of the E pair, which Ångström used as his standard line, is thereby increased from 5269.12 to 5269.80. The wave-length of the line selected by Peirce as a standard was made the subject of repeated careful investigations by him, and more recently by Rowland and Bell; Peirce's first value being 5624.825, his second 5624.86, and Rowland's corrected value 5624.66. Since Rowland published the above list Bell has redetermined the

^b *Recherches sur le Spectre Solaire.*
Upsal. 1868, p. 31.

^c *Publ. des Astroph. Obs. zu Potsdam,*
vol. v. p. 147.

^d *Amer. Journ. of Science,* 3rd Ser.,
vol. xxxiii. p. 182. March 1887.

^e *Visual Solar Spectrum in 1884.*

^f *Amer. Journ. of Science,* 4th Ser.,
vol. xviii. p. 51. July 1879.

^g The third line of hydrogen, "near G."

^h *Sur le Spectre du Fer.* Upsal. 1885,
p. 25.

wave-length of D_1 , his standard line, and found for it a slightly larger value, viz. 5896.18ⁱ.

As the bulk of spectroscopic observations are still made by means of prisms and not of gratings, it is necessary to find some means for converting the measures as made with the spectroscope, whether these be angular deviations or revolutions of a micrometer, into wave-length. The readiest way to do this is as follows:—A scale of wave-lengths is marked off along one edge of a sheet of paper ruled into small squares, and a scale corresponding to that of the instrument at right angles to it. A series of careful measurements must then be made of several of the principal Fraunhofer lines, spread as evenly as possible through the spectrum, and their wave-lengths ascertained from Ångström's map. Then a perpendicular is drawn on the paper from each measure to intersect that through the corresponding wave-length, and a curve as regular as possible is drawn through the points of intersection. Then if the position on the curve of any measure be found, the wave-length required will be directly opposite it on the scale of wave-lengths.

Or the distance of the line the wave-length of which it is desired to determine may be measured from two standard lines, one on either side of it. The wave-length required can then be computed by the following formula, provided that the standard lines be near the centre line:—

$$\lambda_2^2 = \frac{n_3 - n_1}{\frac{n_2 - n_1}{\lambda_3^2} + \frac{n_3 - n_2}{\lambda_1^2}} ;$$

where n_1 , n_2 , and n_3 are the readings for the 3 lines on the scale of the spectroscope, and λ_1 , λ_2 , and λ_3 their wave-lengths, 1 and 3 being the standard lines, and 2 the line under measurement.

Within the last 10 years several maps of the solar spectrum have been produced with much greater dispersion and on a larger scale than those of Kirchhoff or Ångström. Vogel at

ⁱ *Amer. Journ. of Science*, 3rd Ser., vol. xxxv. p. 363. May 1888.

Potsdam, Fizez at Brussels, Smyth at Winchester, and Thollon at Nice have each produced maps showing much more detail than the two great standard charts. Thollon nearly up to the time of his death was engaged on a most magnificent work, in which the spectrum is presented under 4 aspects:—(1) as seen when the Sun is but 10° high, but with the air fairly free from aqueous vapour; (2) as seen when the Sun is 30° high, and the air near saturation; (3) the same but without the water-lines; (4) the solar spectrum cleared of all the lines due to our own atmosphere. The map commences with A, and Thollon carried it up to *b*. But though he was compelled to stop short when only one-third of his task was done, the spectrum as it stands is more than 10 metres in length and shows about 3200 lines. The completion of the work has been undertaken by Trépied.

This work of mapping the spectrum by direct eye-observation is one of the most toilsome possible, and it has been of late years superseded by a method which has much more even than its ease and rapidity to recommend it, the method, that is, of photography. Not merely are the spectral lines at once recorded in their true positions, but, a much more difficult point for the eye to secure, with their correct appearance, intensity and breadth. As early as 1874 Rutherford had published a beautiful lithograph prepared from a fine photograph which he had secured of the blue and violet regions. This was a prismatic spectrum. A most superb photograph of the normal or diffraction spectrum has recently been published by Rowland on a scale considerably greater than had ever been attempted before and showing an amount of detail hitherto unequalled.

Photography laboured at first under one serious disadvantage, which at the same time was for some purposes a merit. The sensitive plate was not equally sensitive to all the rays of the spectrum, and therefore photographs were generally confined to the blue and violet regions. But counterbalancing this drawback is the property which the silver salts possess of being acted on by those rays yet shorter than the violet which escape

detection by our sight. The unseen ultra-violet spectrum is recorded by the photograph as readily as the visible green or blue, and we have from Cornu a map of the unseen region beyond the violet as much the standard for that district as Ångström's map is for the visible spectrum. Lockyer made great use of photography in his continuation of the work Kirchoff had begun, the comparison of metallic spectra with that of the Sun, and was rewarded by being able to double the number of known solar elements.

Huggins long ago put photography to a far more difficult work than that of registering the solar lines, for in 1864, in company with Miller, he obtained photographs of the spectra of some of the brightest stars. Later, in 1879, he took up the work again with more perfect appliances and with more sensitive plates, and obtained a series of negatives of the utmost importance. Sirius, Vega, and other stars of the same type showed a remarkable series of broad shaded lines in the violet and ultra-violet. The lines in the violet were the well-known hydrogen lines *G* and *h*. Then came *H*, and following it, 9 lines of similar appearance, which Huggins has designated by the letters of the Greek alphabet. Of these, *H* and the lines α , β and γ have already been identified by Vogel as due to hydrogen, and so evidently do the entire 12 compose one and the same rhythmical series, and so closely do they correspond with each other in character and appearance, that there need be little hesitation in ascribing the others to hydrogen also. The entire series of lines with their wave-lengths are as follows^k:—

<i>G</i> 4340	α 3887.5	δ 3767.5	η 3717.5
<i>h</i> 4101	β 3834	ϵ 3745.5	θ 3707.5
<i>H</i> 3968	γ 3795	ζ 3730	ι 3699

These 12 lines do not present the same appearance in all stars that they do in Sirius and Vega. They are narrower in η Ursæ Majoris than in Sirius, in Altair and Spica than in η Ursæ Majoris, and so on till we come to α Cygni, where we have a spectrum approximating to the second or solar type, and

^k *Phil. Trans.*, vol. clxxi, p. 669. 1880.

which shows the Huggins series as dark narrow defined lines. Then come spectra unmistakeably of the solar type, such as Arcturus and Aldebaran. In these the Huggins series are for the most part narrow, and not conspicuous; but as in the visible portion of the spectrum, so in the ultra-violet, there are a great number of lines other than those of hydrogen, and of every variety of character. One peculiarity must be mentioned. The solar spectrum shows 2 great lines, or rather shaded bands, due to calcium. Most stellar spectra show these two lines also, but generally as no longer forming a pair. In the stars of Secchi's 1st type we find H resembling the other members of the Huggins series, but K is either wanting as in η Ursæ Majoris, or is

Fig. 169.

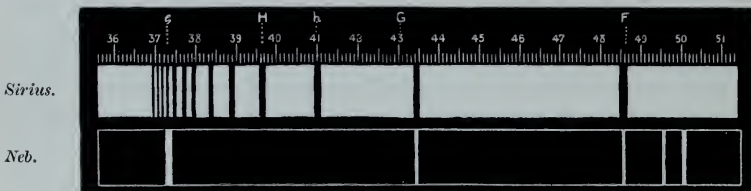
PHOTOGRAPHIC SPECTRA OF SIRIUS AND OF THE GREAT NEBULA IN ORION (*Huggins*).

a narrow well-defined line as in Vega. But in the stars of the IInd type, whilst the other 11 members of the Huggins series are narrow and sharp, H is broad and diffused; and K resembles it, in some cases, Arcturus for example, being even broader and more diffused than its companion.

In 1882 Huggins turned his attention to photographing the spectra of nebulae, and obtained a photograph of the Orion nebula which showed a bright line in the ultra-violet apparently corresponding to ζ of the series of dark lines discussed in Vega and Sirius. H. Draper, who was photographing the same object a few days later, obtained a slightly different result, as his plate did not show the line supposed to be ζ , but instead an indication of the presence of some extremely fine lines in the violet. Huggins repeating his experiments in 1888, found the line he had previously supposed to be ζ was really at wave-length 3724. Two others at 3709 and 3699 were seen near it, besides

three groups of bright lines which lay across the spectra of some of the stars in the nebula, and extended into the nebula beyond. In 1889, whilst the lines at 3709 and 3699 were shown, that at 3724 was missing. The cause of the variation of this line is at present quite unknown. Some seven fresh lines were however detected, 3 at the extreme furthest limit of the spectrum.

Huggins and Draper were prompt to seize the opportunity presented by Tebbutt's Comet of 1881 to photograph its spectrum, and Huggins's plate showed not merely a continuous spectrum clearly crossed by the Fraunhofer lines, but also 2 groups of bright lines in the ultra-violet coincident with those of cyanogen¹. Wells's Comet in 1882 failed on the contrary to give the cyanogen bands, but instead, showed a continuous spectrum with 5 bright bands at wave-lengths 4253, 4412, 4507, 4634, and 4769. The photograph was taken on May 31, when the comet was rapidly approaching perihelion^m.

More recently still Huggins has photographed the spectra of the planets. The plates from Saturn and Uranus show only the solar spectrum with no trace of bright flutings or dark bands analogous to those seen in the visible portion of the spectrumⁿ.

Whilst Huggins was engaged in these various researches in England, H. Draper was engaged in precisely similar work and with almost equal success in America. On his death in November, 1882, his widow, as the most suitable tribute to her husband's memory, supplied Harvard College Observatory with the necessary instruments and funds for carrying on the work to which her husband had devoted his energies. Three Annual Reports of the "Henry Draper Memorial" have now been published, and the work which they record is simply marvellous, both as to amount, importance and beauty. A fuller notice is given in Book IX., *post*, "Astronomical Photography."

Photography is not the only means by which the ultra-violet region of the spectrum is rendered visible to us. There are certain substances which under the influence of light become

¹ *Report of Brit. Assoc.*, 1881, p. 520.

^m *Report of Brit. Assoc.*, 1882, p. 442.

ⁿ *Month. Not.*, vol. xlix. p. 404. June, 1889.

self-luminous, but the light they emit is of a lower refrangibility than that by which they are excited. Stokes, who has made many researches in this field, proposed to call this phenomenon "Fluorescence," from fluor-spar, one of the substances of this class. By reason of this quality the spectrum beyond the visible limit in the violet may be made to produce upon the eye the effect of light. The substance most frequently used for its fluorescent qualities is a clear solution of quinine in very dilute sulphuric acid.

Corresponding to the ultra-violet portion of the spectrum on the one hand, there is another invisible portion, the infra-red, on the other. Sir W. Herschel discovered that beyond the limit of the spectrum as it appeared to the eye there was a positive increase in the heating power; and many years later, Sir John Herschel obtained a record of this spectrum by allowing it to fall on a piece of blackened paper moistened with alcohol. As the drying effect was not uniform, but interrupted here and there, it was clear that there were dark bands in this part of the spectrum as in the visible portion. Becquerel brought out these absorption bands by painting a strip of paper with a phosphorescent substance such as sulphide of strontium, and allowing a bright solar spectrum to fall upon it. The phosphorescence was checked where the spectrum fell upon it, not only in the visible portion, but a considerable distance into the infra-red. But the places of the absorption bands were indicated by the fact that the phosphorescence still continued there. His son Henri Becquerel has continued his researches, and has traced the infra-red spectrum to wave-length 14800, a distance twice as far below A as A is below H.

As early as 1843 Dr. J. W. Draper had succeeded in obtaining a photograph of a small portion of this unseen region. This photograph was a *reversed* one. The plate was first exposed to white light, and then to the infra-red spectrum. Where the clear spaces between the absorption-lines fell on the plate, the previous action of the white light was checked; that portion of the plate could not be developed: where there were absorption

lines, it was left unhindered. The photograph, which was a Daguerreotype, therefore showed the absorption-lines white on a dark ground.

In 1875 Abney made a great advance by showing that it was possible to render the photographic plate directly sensitive to these invisible rays, and he has succeeded in presenting the spectrum as far as wave-length 22000, or 4 times as far below A as H is above it. Nearly 600 lines have been recorded by this method.

But the method which has carried our knowledge of this unseen region the furthest is that made use of by Langley, who has been enabled by his invention of the bolometer to detect the minutest variations of temperature. By carrying the bolometer down the spectrum, and noting the deflections of the needle at every point passed through, it was easy to see when an absorption-band was being encountered. In this way Langley mapped out the solar spectrum so far as wave-length 27000, or more than five times as far from A as A is from H. Terrestrial sources of heat have been traced much further still, Langley estimating the value of the longest wave-length detected by his bolometer as 300000 tenth-metres; the wave-lengths from lamp-black surfaces at the temperatures of boiling water and melting ice being estimated at 75000 and 110000 respectively.

The extreme limit of the solar spectrum towards the violet as recorded by photography is, according to Cornu, at about wave-length 2950. The extreme limit of light from terrestrial sources is given as at wave-length 1850. The extreme limit of the solar spectrum, according to Langley, in the other direction is about 27000. As the range of the visible spectrum does not pass much beyond K in the one direction and A in the other, under ordinary circumstances we may take its limits as being from about 3800 to 7800, or 4000 tenth-metres. The spectrum therefore, as recorded for us by photography, is fully 5 times as long as that directly visible to us, and a further section of greater length than the visible portion has been revealed by the bolometer alone.

BOOK IX.

ASTRONOMICAL PHOTOGRAPHY.

HISTORICAL SURVEY.

Three stages of Astronomical Photography.—The Daguerreotype.—The Collodion and Gelatine processes.—Advantage of Reflectors for Photography.—Adaptation of Refractors.—Solar Photography.—The two forms of Photoheliograph.—Transits of Venus.—Total Solar Eclipses.—Lunar Photography and Libration.—The first photographs of Nebulæ and Comets.—Pickering's determination of Stellar Magnitudes by Photography.—Espin's.—The Brothers Henry.—Photograph of the Pleiades.—Robert's photographs of Nebulæ.—The Photographic Congress.—The Cape Photographic Durchmusterung.—Photography at the Paris Observatory.—Stellar Parallax.—Observation of Meteors.—Spectrum Photography.—Vogel's dyed plates.—Abney's infra-red Photographs.—Huggins's Stellar Photographs.—The Draper Memorial.—The province of Photography.

PHOTOGRAPHY in its application to Astronomy has passed hitherto through three well-defined stages^a. The first was that of the Daguerreotype, in which a solid metallic surface was rendered sensitive; the second, the collodion process, in which a film of collodion was made the vehicle of the sensitive salt; and the third, that in which gelatine has taken the place of collodion. Little interest attaches now to the Daguerreotype except from the historical point of view; it was so soon replaced by the more convenient and more sensitive collodion processes. Still it should not be forgotten that the earliest photographs in almost every department of astronomy were taken by this method. From its very beginning photography gave promise of its future

^a There is a good history of Astronomical Photography by Rayet in the *Bulletin Astronomique*, vol. iv. p. 165 *et seq.*, 1887.

usefulness to the science ; Daguerre himself seems to have made experiments, though apparently without success, as to the practicability of photographing the Moon, whilst J. W. Draper took up the new art with such energy and skill that though the discourse in which Arago described to the Paris Academy of Sciences the details of Daguerre's process had only been pronounced on Aug. 10, 1839, yet early in the following year he was able to present a successful Daguerreotype of the Moon to the New York Lyceum of Natural Sciences. This, the first astronomical photograph ever taken, was about one inch in diameter, and had required an exposure of about 20 minutes.

The same able physicist applied photography to the delineation of the spectrum, and in 1843 obtained a Daguerreotype of almost the whole of the spectrum ; the blue violet and ultra-violet being directly represented on the plate, but the red and infra-red being shown *reversed*, *i. e.* the Fraunhofer lines were white on a black ground. The middle of the spectrum, the orange-yellow and green, left no record. Solar photography was also early attempted, and in 1845 Fizeau and Foucault secured some successful Sun-pictures. A yet greater advance was made in 1851, when Berkowski took advantage of the total eclipse of July 28 of that year to photograph the prominences during the total phase. Star photographs seem to have been first taken at the Harvard College Observatory by W. C. Bond and Whipple. Vega and Castor gave definite images on the plates : the latter appeared elongated, but was not divided.

On the whole, however, the astronomical photographs of this period had little direct scientific value. They were interesting novelties, and supplied significant hints of what might be accomplished with more suitable means. But so long as the Daguerreotype was the only process practically available no great progress could be made. It has however been again brought into use in more recent years on two important occasions, namely, the Transits of Venus in 1874 and 1882. The French astronomers who observed these Transits preferred the Daguerreotype process to those which have succeeded it, on account of one

important advantage which, in spite of all its drawbacks, it possesses over them. In the Daguerreotype the image is formed upon the metallic plate itself; in the collodion and gelatine processes the sensitive film, being distinct from the plate which supports it, is liable to various distortions, which may arise from a want of perfect cohesion between the two. It is questionable, however, whether this advantage is sufficiently decided to encourage its use in other departments of astronomy.

The collodion and gelatine processes have had a very different record, and the former held the field for many years. Despite, however, its superior simplicity and sensitiveness to the Daguerreotype, it had some special drawbacks of its own. If a wet plate process was employed, the entire work had to be finished off in one continuous operation; the plate must be coated, sensitised, exposed, developed, fixed without any sensible interval of time between the various operations. This was a great drawback to the application of photography to astronomy; the few precious moments of fine definition might often be wasted whilst the plate was being passed through its preparatory stages, or it might well happen where long exposures were required, or passing cloud delayed exposure, that the carefully prepared plate was spoiled by the interval which elapsed before its development. Various operators attempted, often with much success, to overcome these drawbacks, until in recent years the substitution of gelatine for collodion as a vehicle has entirely obviated them. The gelatine plates now so widely in use can be prepared in large quantities by skilled manufacturers, at but a trifling cost; and almost any required degree of sensitiveness can be imparted to them. They can be kept both before and after exposure for a very considerable time, and the exposure itself may be almost indefinitely prolonged. Whatever advantages for terrestrial work were possessed by the various collodion processes, it is obvious that for general astronomical work these simple, convenient, and sensitive gelatine plates far surpass them, and indeed it was not until they came into use that any great and important advance was made.

As in the Daguerreotype period, so in the collodion period, the first object attempted was the Moon, Dancer of Manchester obtaining some excellent negatives in Feb. 1852 with an object-glass of $4\frac{1}{4}$ in aperture. He was followed by a number of earnest workers, Phillips, Baxendell, Hartnup, Crookes, Grubb and Fry, all of whom, like Dancer, used ordinary refracting telescopes for the work, a small camera-box being substituted for the eye-piece. Crookes in particular succeeded in securing good pictures of the Moon $1\frac{1}{3}$ in in diameter with the 8-inch equatorial of the Bidston Observatory.

But though all these were more or less successful in their attempts, their results were surpassed by De La Rue, who constructed a reflector of 13in aperture and 10ft focal length. This instrument gave De La Rue a great advantage over his fellow-labourers, for the reflector necessarily brings all rays, no matter what their colour, to the same focus, whilst the ordinary achromatic refractors are constructed to bring the brightest rays of the visible portion of the spectrum to the same focus, but the red and violet rays are neglected. If a spectroscopie be carefully focussed, and then so placed that its slit is in the same plane as the principal focus of an ordinary refractor, and a star be brought on to the slit, the spectrum of the star forms a narrow bright line, very sharp and narrow in the yellow, green and greenish-blue, for the object-glass of the telescope brings all these rays practically to the same focus. But the spectrum begins to spread out in the blue, and gets wider and wider towards the violet, showing that the slit is not in the focus of the telescope for these rays, and the error becomes worse the further we advance in this direction. But it is just the blue and violet rays which are most effective upon the sensitive plate. If an ordinary collodion plate containing iodide of silver be exposed to the spectrum, it will be found that an image is formed from about the E line in the green to the extremity of the spectrum in the ultra-violet. But the deposit of silver after development will not be equally dense throughout the region thus photographed. If a curve be drawn having its ordinates proportional to the

thickness of the reduced silver, it will be found that from E nearly up to G the curve is low and flat, that near G it rises suddenly to a maximum, and that beyond it sinks down gradually in the ultra-violet. It is therefore the rays in the neighbourhood of G and immediately above it that are most energetic in their action on the sensitive plate.

But turning back to the spectrum of the star and moving the spectroscope till the spectrum becomes as sharp and narrow as possible at or near G, in other words till the slit is in the plane of the focus of the object-glass for G, it is seen that the part of the spectrum which is a mere line is much shorter than before, and that the violet widens out in one direction, and the red, green and blue in the other: few rays, that is, come to focus at the same place as G, and some rays which are photographically active, as shown by the density curve, evidently require a somewhat different focus. There was therefore a double drawback to photography with a refractor: there was loss of light, and loss of sharpness. These considerations have led Common and Roberts in recent years to follow De La Rue in the use of a reflector for astronomical photography, and the course they have adopted has been attended with the most conspicuous success.

Still, refractors can be made available for photography. De La Rue himself in 1857 had a telescope specially prepared for solar work, in which the object-glass was corrected for the blue and violet rays, rather than for those rays which impress the sight the most vividly. The Sun as looked at with such an instrument appears to be surrounded by a green ring. In 1864 Rutherford took a yet bolder step, for he had an object-glass of $11\frac{1}{4}$ in diameter, at that time considered a very large lens, constructed with correction of the rays of chief photographic action, thus rendering it useless for general eye observation. Until quite recently, most of the best astronomical photographs were obtained with telescopes of this description, achromatics for the sensitive plate, though not for the eye; but Common and Roberts have again brought the reflector into successful competition with the refractor.

The reflector has this great advantage over the photographic refractor, that it remains as available as ever for other kinds of work; it is not spoiled for use with the spectroscope, or for direct eye observation, because it has been used photographically. But a refractor may be made available for the two kinds of work by one of the following expedients. The lenses of the object-glass may be separated a little until the violet rays come to focus. This is the plan adopted by Janssen at Meudon for his solar photographs. The object-glass is not spoiled for the eye by this method, for the lenses can, if desired, be brought together again. It has also been a point with Janssen, by giving only a short exposure, to use only the rays of greatest activity, namely those near G, so that his photographs may almost be said to be taken with monochromatic light, and they are therefore especially sharp. For the new 28-inch refractor of the Royal Observatory, Greenwich, and which is to be used both for direct and photographic observation, Stokes has proposed the *reversal* of the crown lens, to correct for the spherical aberration introduced by the separation of the lenses. Another method is that employed at the Lick Observatory, Mount Hamilton, in which the correction for the photographic rays is effected by a third lens, a crown glass meniscus of 33ⁱⁿ aperture, which can be readily placed in position before the object-glass when a plate is to be exposed, and as readily withdrawn when the telescope is again to be used for eye-observation.

A third method has been experimented upon at the Royal Observatory, Greenwich, a small correcting lens, consisting of a concave crown and convex flint lens, in contact, having been placed about 30ⁱⁿ within the focus of the 12.8-inch refractor to correct the chromatic aberration of the object-glass for the photographic rays without alteration of the focal length. The meniscus placed before the object-glass of the Lick equatorial reduces its focal length by about ten feet.

The first celestial object photographed, with something like a useful practical result following from the picture, was the Sun, for the drawbacks attending the collodion process were less felt

in working on this object than on any other. As soon as it had been demonstrated by the labours of Schwabe that the spots on the Sun varied in something like a regular cycle, it became evidently of the greatest importance to obtain as continuous and perfect a record of the state of the solar surface as possible, and such a record photography could give almost perfectly. In our climate there are so large a proportion of days in which the Sun only shows itself for a few moments between breaks in clouds that a method which like that of photography can give in an instant a detailed representation of the entire solar surface has an immense advantage over the slow and toilsome process of sketching from direct eye observation. Sir John Herschel was one of the first to urge the commencement of these "solar autographs" as Selwyn termed them, and in 1857 De La Rue designed the "Kew" photoheliograph, which has served as a model for a number of subsequent instruments. This consisted of a telescope of 4ⁱⁿ aperture, and about 5^{ft} focal length, mounted equatorially and driven by clockwork so as to follow the Sun in its apparent motion across the sky. The object-glass was corrected for the photographic rays, and the eye-end was furnished with a camera-box; whilst instead of an eye-piece a lens was employed to throw an enlarged image of the Sun into the camera, the image of the Sun in the first focus of the telescope being only about $\frac{1}{2}$ ⁱⁿ in diameter, but the enlarged image being about 4ⁱⁿ. Lastly, a thin plate, having in it a slit of adjustable width, was placed so that it could be drawn by a powerful spring very rapidly across the principal focus of the telescope. This effected the exposure of the plate, which could thus be made indefinitely short, say from $\frac{1}{1000}$ to $\frac{1}{50000}$ of a second.

The Kew photoheliograph was kept at work from 1858 to 1872. In the following year it was transferred to the Royal Observatory, Greenwich. It was superseded there in 1875 by a similar but somewhat improved instrument, and a series of photographs, as continuous as our climate permits, has been taken there ever since. Since the commencement of 1882, the gaps in the

Greenwich series have been supplemented by photographs taken with similar instruments either at Dehra Dûn, N. W. Provinces India, or at the Mauritius. For the years preceding 1882 a number of photographs are available to supply the deficiencies of the Greenwich series, and some of these have already been measured for incorporation with it. Selwyn's "Solar Autographs" from Ely, Sun-pictures from Calcutta, Dehra Dûn and Melbourne, and a valuable set from the Harvard College Observatory, have already been laid under contribution.

These last were taken with a photoheliograph, but one of a very different design from that of De La Rue's. The aperture of the object-glass and the diameter of the Sun's image on the plate were not very different to what they were in the Kew instrument, but no enlarging lens was used: the photograph was taken in the primary focus, but the focal length of the object-glass was nearly 40^{ft}, instead of 5^{ft}, so that this primary image in the Harvard photoheliograph was nearly of the same dimensions as the enlarged image in that designed by De La Rue. This form of instrument, which was designed by Winlock, has received the name of the "horizontal photoheliograph," for as a telescope 40^{ft} in length would be cumbrous to mount as an ordinary equatorial, it was rigidly fixed in an horizontal position, and the Sun's rays reflected into the object-glass by an heliostat. There are several obvious advantages in this arrangement. The exposing slide may be mounted in perfect independence of the plate-carrier, and so all risk of its communicating a tremor to the plate may be avoided; the plate-carrier can be set up in the dark room itself, a real advantage when wet plates were used. But the scale of the image is definitely fixed, depending as it does solely on the distance from the object-glass to the plate. This is an advantage of prime importance in some researches, the observation of the Transit of Venus, for example; in others it is a drawback. Thus in 1882 the size of the Sun-picture taken at Dehra Dûn was increased to 8ⁱⁿ; the Greenwich Sun-pictures were brought up to the same scale in 1884, and the Mauritius in 1885, and now

occasionally Sun-pictures 12^{in} in diameter are taken at Dehra Dûn. These changes were effected simply by inserting a new enlarging lens, bringing it a little nearer the primary focus than the old one had been, and moving the position of the plate-carrier farther back. The "horizontal photoheliograph" is open to no such change, unless the principle of taking the picture in the primary focus is discarded.

The principal outcome of these photographs hitherto has been simply to confirm the results obtained previously by patient eye-observation; the results of Schwabe, Carrington, and Spörer. Schwabe had shown that Sun-spots vary as to area and number in a period, which is on the average about 11 years in length. Carrington had shown that spots near the equator of the Sun move more swiftly than spots near the poles; more swiftly relatively as well as absolutely, so that whilst a spot on the equator completes its rotation in about 25 days, one at latitude 25° would take about 26 days. Spörer has further shown that Sun-spots do not frequent the same regions of the Sun all through the Sun-spot period. Immediately after the period of minimum, the time of no spots, we find spots, few in number at first, appearing in comparatively high latitudes. As time goes on and the spots increase in number and size they fall in latitude, and after the maximum is passed, and they are beginning to decrease, they still fall in latitude, until at the time of the next minimum, the last few small spots observed are seen close to the equator, and there only. None of these important laws were indeed discovered by the means of photography, it was applied to the study of the Sun too late, but each has been fully confirmed and illustrated by the photographic record.

Wilson's inference, that Sun-spots are hollows in the solar surface, was abundantly confirmed by De La Rue's photographs^b. Of 530, 86 per cent. behaved as depressions should do when seen under various conditions of perspective; the remaining 14 per cent. may be partly accounted for by the formation of

^b *Researches in Solar Physics*, part i. p. 20.

photospheric bridges above the spots hiding their true shape, and partly perhaps by exceptional formations in the spots themselves. An exceedingly pretty demonstration of Wilson's theory was given by the application of the principle of the stereoscope. In 1861 De La Rue obtained a pair of Sun-pictures at a suitable interval of time apart, and when viewed in the stereoscope the faculæ evidently occupied the highest portion of the photosphere, whilst the spots appeared like holes^c. A further confirmation of Wilson's theory has been supplied by the cases in which a spot has actually been seen on the photograph as a notch on the Sun's limb, or a facula as a tiny projection.

De La Rue also found that his photographs showed a very marked predominance of spots with faculæ following them, over spots with faculæ preceding them, from whence he inferred that the faculæ had been uplifted from the very area occupied by the spot with which it was associated.

A point of great interest raised by De La Rue still awaits final settlement. So far as the series of photographs went which he was able to discuss, it appeared not improbable that the planets, Venus especially, and Jupiter in a lesser degree, had an influence on the growth and behaviour of a spot after it had once formed, the tendency being for a spot to attain the greatest dimensions when in that part of the Sun furthest from the planet.

With regard to the faculæ, the photographs have shown that they increase and decrease in number and size just as the spots do, and at the same time. But besides these more striking features of spots and faculæ, attentive observation shows that there are tiny bright points alternated with comparatively dull intervals over the entire surface; these are called the "rice-grains," or, taken as a whole, the "mottling" of the surface; and observations made under specially favourable circumstances tend to show that they are but the aggregation of still minuter formations. These rice-grains have never been better shown than in the fine Sun-pictures obtained by Janssen at Meudon, pictures which

^c *Phil. Trans.*, vol. clii. p. 406. 1862.

bring out clearly the curious fact that there are vast areas of the Sun's disc over which these rice-grains appear confused and smudged, whilst in neighbouring districts they appear sharp and distinct, so that the entire Sun appears covered by an intricate network which has been termed "*le réseau photosphérique.*" It has been suggested that these blurrings are due to disturbances in the upper portions of the solar atmosphere, but Janssen himself prefers to think that the actual "rice-grains" themselves—whatever their nature—are really confused and ill-defined in these particular regions, which are probably regions of storm.

A particularly fine photograph obtained by Janssen on June 22, 1885, has shown that the striations of the penumbra and the faculæ surrounding it are composed of granulations similar in form and shape to those which make up the general surface of the Sun. Janssen inferred that these granulations are in truth the constituent elements of every portion of the solar surface^d.

The two forms of photoheliograph were employed in 1874 and 1882 during the Transits of Venus, the American astronomers using the horizontal, the English the improved "Kew" form. This was a case in which photography promised to be of great value, as by its means an accurate record of the apparent position of Venus as seen at any station could be obtained, and the photographs being brought together from the various stations could be compared at leisure, and the displacement of the planet as seen from the various stations, and which is due to parallax, could be accurately measured at leisure. Difficulties, however, were experienced in the practical carrying out of the plan, and the English photographs of the 1874 transit were not regarded as of sufficient value to warrant a repetition of the experiment in 1882. The French and American astronomers were, however, much more successful, and the latter regard the value they obtained for the Sun's distance from their photographs with very considerable confidence. The following are the values for the Sun's parallax obtained from the measurement of the photographs taken during the two transits:—

^d *Comptes Rendus*, vol. cv. p. 326. Aug. 16, 1887.

French	1874	8.80
American	1874	8.883 ± 0.034
„	1882	8.847 ± 0.012

Perhaps the most important contribution to our knowledge of solar physics which photography has made has been during the observation of solar eclipses. A total solar eclipse lasts so short a time, and there is so much to see and note during its occurrence, that it need not be a matter of surprise that drawings of the phenomena observed differ very widely. This is just a case where the testimony of the camera is invaluable, and the photographs have conclusively proved that both the prominences and the corona truly belong to the Sun. In the 1860 eclipse the photographs of Secchi and De La Rue showed that the prominences were gradually covered up on the one side by the dark body of the Moon as it passed before the Sun and uncovered on the other, thus conclusively proving that they belonged to the Sun. Then, again in 1871, photographs of the Sun's corona obtained at stations hundreds of miles apart gave so precisely the same details of form and structure that no doubt can remain that, in its main features at least, the corona is a truly solar phenomenon. These results were of the utmost importance, since if the corona and prominences had proved to be merely the effects of our own atmosphere, we could have had little or no reason for observing them; but as solar phenomena they became of the highest interest. The prominences can now be observed in full sunshine by means of the spectroscope; the corona evades the spectroscopic method, and hence it is still regarded of the utmost importance that photographs of it should be secured during every successive solar eclipse.

The Moon, which was the first celestial object to be successfully photographed, has been photographed very frequently since; but the photographs secured by Rutherford in 1864 remain amongst the very best yet taken. The great majority of the earlier lunar photographs were taken in the primary focus of the telescope, and were therefore on too small a scale to give us much information as to the minute details of its surface. Burton,

however, succeeded in 1882 in obtaining some pictures with a magnification of 8 diameters; and more recently at Paris MM. Henry have produced some very promising pictures of isolated districts on a greatly enlarged scale. The great Lick telescope has so long a focus that the image of the Moon in its first focus is already $5\frac{1}{8}$ in diameter, and a photograph taken there shows an immense amount of fine detail. A detailed photographic survey of the Moon on a large scale is clearly a work that may be expected to be carried out in the near future. Such a survey would be of the utmost value, and would eventually set at rest the question as to the reality of changes of any appreciable magnitude on the lunar surface.

One series of lunar photographs has already proved of definite value. These were taken at the University Observatory, Oxford, under Professor Pritchard's direction, for the determination of the amount and position of the lunar libration, and the plates proved to be not only exceedingly suitable for exact and delicate measurement, but some of them, having been enlarged, are not inferior in beauty and detail to the very best which had been previously obtained.

Up to about the year 1880 the only really useful celestial photographs that had been obtained were those of the Sun and Moon, and so long as only collodion plates were available, there seemed no prospect of making any great advance. The light of planets, comets, stars, and nebulae is so comparatively feeble, that prolonged exposures were necessary; so prolonged that no ordinary driving clock would keep the telescope exactly pointed upon the object to be photographed during the entire time. Yet if this was not done with the most perfect exactitude, no satisfactory results could possibly be obtained; otherwise stars would appear on the plates as streaks, and comets and nebulae as mere smudges. Notwithstanding however all the drawbacks of the manipulation of collodion plates, and the difficulties of securing that the telescope followed the object with unerring precision, not a few very promising photographs were obtained. De La Rue photographed Jupiter and Saturn, but on too small

a scale for the results to have any great value. Rutherford and Gould got some very striking and promising photographs of stars, but no important use was made of them. The measures of Rutherford's double-star plates showed indeed that a photograph would yield quite as accurate results as a direct measure at the telescope, and a successful set of measures was made of the principal stars in the Pleiades which proved to be of value. Otherwise little had been done, even with stars, and nebulae and comets seemed quite beyond the reach of photography. But the introduction of gelatine plates and the very rapid improvements which were made in them effected a great revolution, and in 1880 H. Draper secured a very promising picture of the great nebula in Orion. Common, who had supplied himself with a reflector 3^{ft} in diameter, attempted the same object at the same time, but failed owing to imperfect clockwork. He persevered, however, in his work, continually improving his clockwork and employing more and more sensitive plates, until at length, on March 17, 1882, he obtained a beautiful photograph, and on January 30, 1883, one still more beautiful. For these and his other successful astronomical photographs he received the gold medal of the Royal Astronomical Society in 1884.

In 1881, another triumph was achieved. On June 24, 1881, Common at Ealing and Draper in America each succeeded in photographing the brightest comet of that year (Tebbutt's). The following year, however, a much greater step in advance was made. A few days after the perihelion passage of the great comet of 1882, Gill, the Astronomer Royal at the Cape, resolved to attempt to photograph it. In this he was assisted by a local photographer, Allis by name, and their efforts were crowned with complete success. Not only was the comet photographed, but the images of many hundreds of stars in its neighbourhood were secured. Of these plates Common said, "They came as a revelation of the power of photography in this direction, and it is probably to them that the increased attention lately given to stellar photography is due."

These comet photographs were obtained by means of a

Dallmeyer rapid portrait lens of $2\frac{1}{2}$ in aperture and 11 in focal length mounted on the declination axis of one of the equatorials of the Cape Observatory; the exposures varying from half-an-hour to an hour. The prolonged exposure rendered it a matter of the greatest importance that the telescope should be kept carefully pointed on the comet. It was therefore necessary not only that the telescope and camera should be driven by a good clock, but that an observer should be seated at the telescope with his hand on the slow motion rods, so that he might at once correct any irregularity in the driving of the clock, and at the same time follow the comet carefully in its orbital motion.

The first set of these comet photographs was laid before the Royal Astronomical Society at the meeting which took place on December 8, 1882. A few months later, on June 8, 1883, E. C. Pickering, Director of the Harvard College Observatory, described to the same Society the work on which he was then engaged, "the determination of the light and colour of the Stars by Photography." For the 4 preceding years he had been engaged on the preparation of the "Harvard Photometry," a photometric determination of the magnitudes of more than 4000 stars, and it occurred to him that photography might be of considerable service in this chosen field of research. If a plate be exposed on a star for too long a time the image of the star will become gradually larger, so that when a number of stars of every variety of brightness are photographed on one and the same plate, the resulting images are of every variety of size, the brightest stars being of course the largest. The photographic magnitude does not, however, correspond precisely to the magnitude as determined by eye-observation, a red star making a comparatively feeble impression on the plate, a blue star a comparatively strong one. A curious example of this fact which Pickering mentioned is the case of α Ceti and a star near it. To the eye the magnitudes of the two are 2.7 and 6.3 respectively, but on the photographic plate they differ by only three-tenths of a magnitude^o. The images of the stars on

^o *Observatory*, vol. vi. p. 203. July, 1883.

Pickering's plates were not however dots, but lines, for as he purposely did not employ a driving-clock the stars were not stationary on the plates, but formed *trails*. For many purposes trails are as useful, sometimes more so, than circular images, and as the object in this case was not to make star maps but to determine magnitudes, trails were at once easier to obtain and more effective. By an ingenious arrangement 18 exposures were made on the same plate, each exposure securing a photograph of a region 15° square, and the whole 18 exposures were obtained in 18 minutes of time. These plates were obtained with a lens of 2^{in} aperture and 7^{in} focal length, and formed an experimental series. Later, a Voigtländer photographic doublet of 8^{in} aperture and 44^{in} focal length was employed for a similar survey, this focal length being adopted because the resulting photographs were on the same scale as the Atlas of the *Durchmusterung*, namely, 2 centimetres to a degree. The plates taken with this larger aperture have been measured and reduced for 3 selected regions, each with special qualifications for the function of standard-stars:—namely, 1000 close circumpolar stars, 420 stars in the Pleiades, and 1100 equatorial stars. The measures of these photographs, some of which showed the stars as discs and some as trails, showed that two independent measures of the same star disc or trail by the same observer did not vary on the average by so much as a tenth of a magnitude ^f.

A very creditable piece of work of the same character was accomplished by Espin at a somewhat early stage in the recent development of stellar photography. This was the publication in 1884 of a catalogue of the photographic magnitudes of 500 stars, from the measurement of the trails obtained with a photographic lens by Grubb of $4\frac{1}{2}^{\text{in}}$ aperture and about 6^{ft} focal length.

Shortly after the publication of Espin's catalogue, Admiral Mouchez, Director of the Paris Observatory, stated in a communication to the Paris Academy of Sciences that MM. Henry, who had been for many years engaged in preparing elaborate charts of the heavens, had at length on reaching the Milky Way found it

^f *Annals of Harvard College Observatory*, vol. xviii. part 7.

almost impossible to continue their work by the old slow methods of direct eye-observation. They therefore determined to resort to photography, and after some experiments constructed a large instrument for the purpose. This instrument is double, having two object-glasses rigidly connected together. The one is for photography, and carries a camera at the eye-end; the other is for direct observation, one of the stars to be photographed being brought up to a cross wire, an observer watching carefully throughout the entire time of exposure to see that it does not leave its place in the slightest degree. The aperture of the photographic object-glass is 13.4ⁱⁿ. The results obtained by the Henry apparatus quite exceeded every expectation, and proved that it was perfectly possible to obtain with a given telescope distinct photographs of stars too faint to be seen with the eye by means of the same telescope. For if a star is too faint to be visible with a given instrument, no prolonged gazing will bring it into view. But with the photograph, it is simply necessary to prolong the exposure to obtain impressions of faint objects. Common used this circumstance to bring out to the fullest extent the varied details of the great Orion nebula. He was not content with taking photographs with prolonged exposures, but he took some which, being only lightly exposed, brought out simply the brightest portions; others with a longer exposure which brought out somewhat fainter details, whilst the most prolonged exhibited the faintest and most delicate extensions of the nebula, some of which had always escaped the perception even of the most skilled and keen-sighted observers. Just as his series of photographs of the nebula in Orion brought out fainter and fainter details of the nebula, so prolonging the exposure of a stellar photograph never fails to bring out ever fainter and fainter stars.

One of the most striking successes achieved by MM. Henry was their photograph of the Pleiades. In an exposure of an hour no fewer than 1421 stars were photographed; but that was not all. A nebula was discovered round one of the principal stars, the existence of which had never been so much as suspected before, and which, even after it had been secured by

means of photography, could not be seen in any telescope of the Paris Observatory. It has since been seen with the great telescopes of the Pulkowa and Nice Observatories, but would probably have entirely escaped notice at both these places had it not been for the previous intimation of its existence which photography had afforded.

This photograph of the Pleiades brings into full relief the marvellous revolution in astronomical methods which photography has already effected. C. Wolf, of the Paris Observatory, an industrious and skilful observer, had devoted 3 years of unremitting labour to the formation of an accurate chart of the Pleiades. His catalogue contains only 671 stars. The photograph taken in one, or rather in 3 hours,—since it is the practice of MM. Henry to expose each plate three times, moving the telescope an infinitesimal amount between each exposure, so that every star is represented by a tiny triangle of spots, and can therefore be at once discriminated from any accidental defect on the plate,—shows more than twice the number of stars that the chart does, and represents them in magnitude and position with perfect accuracy. The chart, despite all the care of C. Wolf, is not absolutely free from error. The work of 3 hours thus compared with the work of 3 years is superior in every respect.

But this photograph of the Pleiades has been completely surpassed by more recent ones, obtained some by MM. Henry themselves, and some by English astronomers. Common and Roberts have especially devoted themselves to nebular photography: the former has recently completed a reflecting telescope of 5^{ft} aperture which is largely to be devoted to this work, and the latter has also preferred the reflector to the refractor for photographic purposes. With the view of obtaining very prolonged exposures, Roberts spared no trouble or expense in providing his telescope with an exceedingly perfect driving-clock, and at length Grubb succeeded in supplying him with one, electrically controlled, which met his requirements. With this Roberts has made successful exposures, even 4 hours in length, with astonishing results, particularly in respect to nebulae. The Pleiades have

been shown to present an almost continuous mass of nebulous matter ; the great Orion nebula has been traced far beyond its old limits, whilst the Andromeda nebula, "now for the first time seen in an intelligible form," has proved to be a vast Saturniform body ; a great comparatively condensed nucleus being surrounded by a series of rings, elliptical as they appear to us, but probably so only from the angle under which they are presented to our view. The photographs which Roberts has secured of other nebulae and star clusters have been only less interesting than this. A single plate exposed on a region in Cygnus has shown more than 16,000 stars ; whilst the spiral nebula in Canes Venatici has been depicted with most wonderful distinctness.

Important as these and other photographs have been individually, they have been yet more so for the consequences opened out by them. Mouchez and the Henrys, so soon as they had demonstrated by their plate of the Pleiades how practicable a photographic survey of the entire heavens had become, and that on a large scale, laid the subject before the astronomers of the world for their consideration. So great a survey could not be carried out by any single observatory, but by several acting in concert it would be quite possible before the close of the present century to survey the entire heavens on a scale which would give us the positions and magnitudes of probably many millions of stars.

Such a record of the heavens seemed a few years ago to be too entirely beyond our reach for its possibility even to be dreamed of, and it cannot be doubted that it will afford the greatest assistance in the solution of the problem which Sir W. Herschel was the first to attack, and will afford most valuable information as to the configuration of the sidereal universe.

Then the repetition of the photographs at definite intervals would show us whether any new stars had appeared or old ones faded out, what stars were variable, and where they were placed. Such a series, too, would lead to the discovery of new minor planets ; and if there be any planets revolving beyond the orbit of Neptune, they would in time be detected. The

question, too, as to variations in nebulæ can receive a far more satisfactory answer from photography than from direct observation.

In consequence of the invitation of the French astronomers a conference on the subject of astronomical photography was held in Paris in April 1887, to consult as to the carrying on of this great survey. The result of the Congress was the adoption of resolutions to the following effect:—

“I. A photographic chart of the heavens containing all stars down to the 14th magnitude is to be at once undertaken, the plates to be in duplicate.

“II. A second series of photographs with shorter exposure, to include stars of the 11th magnitude, is to be made concurrently with the first, for the purpose of forming a catalogue and to determine fundamental positions in the first series.

“III. The photographic plates are to be prepared from the same formula.

“IV. The photographic telescope is to be identical in all essential particulars with that used by the Brothers Henry at the Paris Observatory.”

Some 14 or 15 observatories are already pledged to join in the work, the English observatories being those of Greenwich, Oxford, Melbourne, and Sydney.

The Astronomer Royal at the Cape has already completed a photographic survey of the Southern heavens on a smaller scale and for a special purpose, as he was desirous that a catalogue of Southern stars should be formed, to correspond to and to complete Argelander's great *Durchmusterung* of the Northern heavens. The measurement and reduction of the photographs have been undertaken by Kapteyn, and the entire work is rapidly approaching completion.

The great International Survey has not yet been actually commenced, but the necessary preliminary inquiries are being rapidly pushed forward, and it will probably soon be begun.

The successive Reports of the Paris Observatory give a vivid idea of the continued advance which astronomical photography

has made. Thus the Report published in 1886 mentioned photographs of the most striking star-clusters, of 600 double and multiple stars, of stars invisible even in powerful telescopes, of the nebulae of Orion and Andromeda, and of the Moon and planets. Photographs of Jupiter and Saturn had been obtained on a large scale, and showed an amount of detail comparable with that which can be perceived under favourable circumstances by direct observation. But perhaps the most striking achievement was the photographing of the satellite of Neptune (an object too faint to be observed with any of the instruments at Paris) in every part of its orbit round the planet.

The Report in the following year gave some measures of photographs of double stars which showed a high degree of precision; thus the mean error of a single measure of distance for ζ Ursæ Majoris was $0.077'$, and of position-angle 0.55° . A little volume published shortly before this report gave a complete account of the progress of astronomical photography, with specimens of some of the results. The lunar and planetary photographs are amongst the most remarkable of these; the former are especially successful, for they are on a scale of about $\frac{1}{2}$ inch to 1 minute of arc, and are full of the sharpest detail.

In 1888 the annual Report chronicled the presentation of more than 30,000 distinct stars on a single plate. Several curious new nebulae had been discovered, the most remarkable of which were in the Pleiades. With an exposure of 4 hours 2326 stars were obtained, instead of the 1421 contained on the earlier photograph, and the nebulae round Merope, Maia, Alcyone and Electra were no longer mere faint clouds, but well-defined nebulosities of intricate and complicated form. Besides these, there were two new nebulae, both very narrow and straight, the longer one some $40'$ in length, and only $2''$ or $3''$ in breadth, and threading together, as it were, no fewer than seven stars.

Besides the direct production of star-charts, photography may prove of no small service as a recording agent. From experiments which Pickering and others have conducted it appears that the substitution of a sensitive plate for the eye of the observer in

watching the transit of a star across the field of a transit instrument can be successfully made: the probable error of a single observation is rather less than greater, whilst the observer's "personal equation" is eliminated. The Sun can be very readily photographed whilst in transit, and in this case there would be the great advantage that the telescope need only be exposed to the Sun's rays for a single moment, whilst at present a complete observation of the Sun occupies several minutes, the Sun pouring down its heat upon the instrument the entire time, and probably disturbing thereby its delicate adjustments.

The exceedingly difficult and delicate work of determining stellar parallax has already received considerable assistance from photography. Gould on his return from Cordoba in 1883 brought with him a number of star-photographs, some of which were taken with a view to ascertaining stellar parallaxes. But these had not been measured or discussed. Pritchard, however, has more recently taken up the matter at the Oxford University Observatory with marked success. 61 Cygni, for example, gave a parallax of $0.4321''$ from the entire series of photographs taken on 89 nights, and $0.4089''$ when only the nights of maximum and minimum distance from the comparison-stars were taken. The parallaxes of minor planets, and consequently the solar parallax, will assuredly be determined in the future by photography as well as by direct observation; indeed Gill has already commenced work upon Sappho.

There is one department of astronomy to which as yet photography has not been applied, but in which it might well be of the utmost value, that is the observation of meteors. The determination of the exact paths and radiant points of meteors is one of considerable difficulty, owing to the shortness of the time a meteor is visible. If we can but contrive that the meteor shall itself record the direction of its motion, several questions now under discussion as to the radiant-points of meteors will receive speedy solution.

There is another department in which photography has been of the most essential service; namely, the observation of the

spectrum; and some reference has already been made in Book VIII., *ante*, "Spectroscopic Astronomy," to the work which has been accomplished in spectrum photography. Much of this work has been confined to those regions, the violet and ultra-violet, which impress themselves readily upon the sensitive plate. But the infra-red and the most brilliant parts of the visible spectrum, though more difficult to photograph, have also been secured. As already stated, the density-curve for the spectrum as photographed on an iodide of silver plate, only begins at E and is shallow nearly up to G. With a bromide plate the action begins much earlier, viz. about B in the red, and gradually increases in depth up to a maximum near G. A bromide plate is therefore much better fitted for spectrum photography than an iodide plate. Still since the maximum sensitiveness lies near the borders of the blue and violet, so far from the point where the eye judges the spectrum to be brightest, a photograph of coloured objects does not strike us as giving a faithful representation of them; for some of the duller tints come out as if they were nearly white, some of the brighter as if they were a dark grey. Vogel however succeeded in altering the range of sensitiveness of plates in a remarkable manner by staining them with different colours; a solution of eosine even made the plate most sensitive to the yellow, usually spoken of by photographers as "a non-actinic colour." It has therefore become possible to prepare plates giving a density-curve under the spectrum which shall accord closely with the brilliancy-curve of the spectrum according to our perception of it, so that coloured objects photographed on such a plate give the same impression with regard to the relative brightness of their different colours as they do to the eye in nature. Such stained plates are however slower than they were before staining.

These dyed plates do not carry the spectrum below the limit of visibility; *i. e.* to about A. Draper had obtained a Daguerreotype of part of the infra-red spectrum in the very early days of photography, but it was a *reversed* spectrum, the Fraunhofer lines coming out white on a dark ground. This

was due to the property of the red part of the spectrum to stop the action of the more refrangible portion. A plate was exposed to diffused white light, which alone would have fogged it. The spectrum was then allowed to fall on the plate, and wherever the yellow and red rays met the plate they prevented its developement. Where the Fraunhofer lines fell they permitted it, and hence the reduction of the silver went on under them.

Abney's photographs of the infra-red spectrum were *direct* photographs, nor did he make use of a dyed film, but after much trouble he succeeded in obtaining the bromide of silver with which he worked in a different molecular condition from that in which it is generally found. It now appeared blue instead of red when viewed by transmitted light; it absorbed rays of every kind, but the lower rays the most, and the green rays the least.

Having thus obtained a record of these two new districts of the solar spectrum, it next became necessary to photograph side by side with the solar spectrum the same districts in the spectra of the terrestrial elements, that we might discover how many and which of the solar lines correspond to the lines of elements with which we are acquainted here. This inquiry has been carried on by Lockyer and others in great detail for the ultra-violet region; the infra-red as yet has scarcely been attempted.

Nearly related to the work of recording the lines in the solar spectrum has been that of recording those in the spectrum of the corona. In the short interval of time a total solar eclipse lasts it is impossible to determine the places of more than a few lines, and it is only too easy to fall into some error in that determination. But the photograph, so long as the lines are sufficiently brilliant, finds it as easy to record the position of a hundred lines as of one. It has, therefore, always been part of the programme of observation for the last few eclipses to photograph not only the corona and prominences, but also their spectra.

The solar spectrum has not been the only one which has been studied photographically. Huggins and H. Draper have photographed the spectra of stars, comets, and nebulae. The results

which the former obtained in his stellar photographs are of great value, since they led to the discovery of a series of lines in the ultra-violet portion of the spectra of the blue stars due to the presence of hydrogen. Historically too, Huggins's stellar photographs are of great importance, as they mark two great advances; the introduction of gelatine plates, and the improvement of the driving-clocks of equatorials. As the slit of Huggins's spectroscope was only $\frac{1}{350}$ in, and the star had to be kept truly central upon it, it was of prime importance that the telescope should be driven with the utmost steadiness.

After Draper's death his widow, desiring to provide a suitable memorial to her husband, supplied to the Harvard College Observatory the necessary funds for carrying on the researches to which he had more especially devoted the last years of his life, and Pickering has undertaken the direction of the work. A three-fold programme has been devised, and its first section, at least, is already in a very forward state, more than 28,000 spectra of 10,800 stars having been examined. First, the photographing, measurement, and cataloguing of the spectra of all stars down to the 6th magnitude from the North Pole to 24° S. Decl. Next, a similar catalogue of stars to the 8th magnitude. Lastly, the study of the brighter stars with high dispersions. The results already obtained under this last head are, without doubt, the most marvellous which photography has as yet contributed to astronomy. A refractor of 11 in aperture was used, with in some cases 4 prisms before the object-glass. A photograph of the spectrum of Pollux was obtained with this dispersion in 50 minutes on such a scale that the distance between H and K was 0.176 in. But the definition was so good that the photograph bore enlarging 5 times as regards its length, and by means of a cylindrical lens its breadth was increased up to 4 in. Thus enlarged, the spectrum of the star was presented on a scale two-thirds of that of the maps of Ångström or Cornu, whilst the lines were shown with most admirable sharpness. Other stars were photographed with equally good results, and it is scarcely too much to say

that Pickering's achievements in this respect will render it possible for us to study the spectra of the brighter stars with as much ease and certainty, and almost in as great detail, as the spectrum of the Sun itself could be, not many years ago.

The photographs for the spectroscopic catalogue are striking examples of the labour-saving qualities of photography. With a single prism before the object-glass, the spectra not of one star alone, but of hundreds, are photographed on the same plate. The saving of time and labour is greater even than in charting the stars themselves, a single exposure recording not merely the places of a number of stars, but the position and arrangement of a number of lines in the spectra of each, a work much more laborious and tedious for eye-observation than the determination of the mere position of the star.

The foregoing sketch will suffice to prove that photography has already become a most powerful weapon of research, but it must never be forgotten that the greatest successes of photography have been obtained under conditions the recurrence of which we cannot ensure at will, and that there is no branch of astronomy where it has yet made direct observation unnecessary. Such pictures as Janssen has secured of the Sun, and the Brothers Henry of the Moon, of Jupiter, and Saturn, require not only perfect instruments and skilful manipulation, but atmospheric conditions far more favourable than those which usually prevail. The advantage which photography possesses over the eye in the study of the spectra of stars and nebulae does not extend equally to the Sun or the planets. If the definition be bad, the photograph must be bad also; it has no power of discrimination, and it faithfully records and presents the sum-total of all the disturbances, instrumental and atmospheric, which have occurred during the time of exposure: whilst the eye, on the other hand, can often succeed in disentangling the image under inspection from accidental tremors, and the observer is able to form nearly as correct an idea of it, though, indeed, with more difficulty, as if the definition were good. Then, again, photography is ill-adapted for the watching of minute or rapid changes. Thus in Sun-spot work,

though nothing could be more efficient than a photograph for giving the positions and areas of the several spots, it is inferior to the eye for recording the changes which from time to time take place amongst them. It fails in precisely the same way in work on the spectrum. Had we been obliged to trust entirely to photography we should have never learned much about the marvellous changes which take place from time to time in prominences and their spectra, and should have lost the lessons so learned. Then certainly, as yet, photography has not been able to surpass eye-observation in the information it can give as to minute details in Sun, Moon, or planets, if indeed it has been able to equal it. It is clear that photography can only supplement, it cannot supersede the work of the keen eye and intelligent brain. Its own field is distinctly marked out for it, and it is a sufficiently wide one. Whenever many observations of a sufficiently bright object have to be made in a short interval of time, as, for instance, the observations made during a total solar eclipse, or whenever the details to be delineated are exceedingly numerous, so as to baffle direct observation by their number, as the lines in the spectrum, the markings on the Sun, the stars in the sky, or the windings of a nebula, photography proves a most useful assistant, and will prove more and more valuable as time goes on. There are also researches particularly its own, as the examination of the ultra-violet and infra-red portions of the spectrum, and the delineation of stars and nebulae too faint to be perceived by the eye. In these departments photography has already done much, and will probably do much more in the near future; how much we can scarcely venture to anticipate, but the progress has been so rapid and the success so marvellous, that we may well look forward with confidence to successes in the future not less striking or less important than those of the yet recent past^g.

^g The only existing treatise on Photography as specially applied to astronomical uses is Konkoly's *Practische Anleitung*

zur Himmelsphotographie, 8vo. Halle, 1887, a comprehensive general work illustrated with 218 engravings.

BOOK X.

CHRONOLOGICAL ASTRONOMY.

CHAPTER I.

TIME GENERALLY.

What Time is.—The Sidereal Day.—Its length.—Difference between the Sidereal Day and the Mean Solar Day.—The Equation of Time.—The anomalistic Year.—Use of the Gnomon.—Length of the Solar Year according to different observers.—The Julian Calendar.—The Gregorian Calendar.—Old Style versus New Style.—Romish miracles.—Table of differences of the Styles.

TIME is, strictly speaking, of indefinite duration; we are, therefore, obliged to choose some arbitrary unit by means of which a measurement of time may be effected. For short intervals, the diurnal rotation on its axis of the globe we inhabit, and for longer intervals, the monthly revolution of the Moon around the Earth and the annual revolution of the Earth around the Sun, are the standards of measurement which we employ; but any events which take place at equal intervals of time would serve the purpose of a chronometrical register. Thus, the number of concentric rings in the trunks of trees; the number of rings on the horns of cattle; the successive disappearance of marks from the teeth of horses; the pulsations of the heart; the flowing of a certain quantity of water from one vessel to another; the oscillations of a pendulum, are all such recurring events as may be employed to measure time: but, in practice, the solar day is a natural interval of time, which the domestic habits of man force upon him; and accordingly we find that this unit of measurement is the one almost

universally adopted. Nor must the fact be lost sight of that not only has our common practice herein its origin in remote antiquity, but that it is a Divine conception. In *Genesis* i. 14 we are plainly told that the Sun and Moon were created to be “for signs and for seasons and for days and years” in addition to their functions as “lights in the firmament.” As we shall hereafter see, more turns upon this than is at first sight evident.

The space of time in which the Earth rotates on its axis is known to us as the *Sidereal Day*; it is determined by 2 consecutive passages of a star across the meridian of the place of observation, and is subdivided into 24 equal portions, called *sidereal hours*, each of which is made up of 60 *sidereal minutes*, &c. The sidereal day may be otherwise defined to be the time occupied by the celestial sphere in making one complete revolution. The duration of this interval can be shown by theory to be all but invariable, and the actual comparisons of observations made on numerous stars, in widely different ages of the world, corroborate this conclusion. Here we have, then, a chronometric unit far surpassing in accuracy anything that could be artificially contrived. Laplace indeed thought that he had ascertained, from a careful comparison of modern with ancient observations, that the length of the sidereal day could not have altered so much as $\frac{1}{1000}$ of a second in upwards of 2000 years, but more recent investigation has rendered it necessary for us to qualify older assertions on this subject, for it is now supposed that owing to friction due to the Tides the sidereal day is now longer by not quite $\frac{1}{8}$ of a second than it was 2500 years ago. But notwithstanding this, the sidereal day may be regarded as possessing practically that indispensable qualification for a standard unit, *invariability*.

The *Solar Day* is reckoned by the interval elapsing between 2 successive meridian passages of the Sun.

The orbit of the Earth not being exactly circular, (and its axis being considerably inclined.) it follows that the daily velocity of our globe round the Sun, or, what for our purpose is the same, the daily apparent motion of the Sun through the

Zodiac, is not uniform^a, and the length of the solar day, therefore, varies at different seasons of the year; this variable interval is called the *Apparent Solar Day*, and time so reckoned is *Apparent Time*. In order to obviate the inconvenience which would attend the use of such a day in reckoning time, astronomers have agreed to suppose the existence of an imaginary sun moving in the equator, with a velocity equal to the Sun's average velocity in the ecliptic. When this fictitious or *mean sun* comes to the meridian, it is said to be *mean noon*; and when the true meridian passage of the Sun takes place, it is *apparent noon*: the interval between the two mean passages being called the *mean solar day*. If the Sun were, like a star, stationary in the heavens, then it is clear, from what has been said above, that the solar and sidereal days would be equal; but since the Sun passes from W. to E. through a whole circle (that is to say, through 360°) in 365·2422 days it moves Eastwards about $59' 8\cdot2''$ daily. While, therefore, the Earth is revolving on its axis, the Sun is moving in the same direction; so that when we have come round again to the meridian from which we started, we do not find the Sun there, but nearly 1° to the Eastward; and the Earth must perform a part of a 2nd revolution before we can come under the Sun again. Thus it is that the mean solar day is longer than the sidereal day in the ratio of 1·00273791 to 1: the former being taken at exactly $24^h 0^m 0^s$, the latter, expressed in mean solar time, is $23^h 56^m 4\cdot091^s$, or $0\cdot99726957^d$. Clocks regulated to keep sidereal time are in general use in astronomical observatories—one revolution of the hands of the clock through 360° , or 24^h , thus representing 1 complete revolution of the heavens; but it is obvious that a sidereal hour is shorter than a solar hour, the difference being $9\cdot8256^s$. 24^h of mean solar time are equal to $24^h 3^m 56\cdot55^s$ of sidereal time. In consequence of the sidereal day being $3^m 55\cdot91^s$ shorter, reckoned in mean solar time, than the mean solar day, the stars all pass the meridian $3^m 55\cdot91^s$ earlier every day. This gaining of the

^a The average daily motion is $0^\circ 59' 8\cdot2''$, it amounts to $1^\circ 1' 9\cdot9''$; with the Sun in but with the Sun in perigee, in January, apogee, in July, it is only $0^\circ 57' 11\cdot5''$.

stars upon the Sun is called the *Acceleration of Sidereal upon Mean Time*: an obvious consequence of this acceleration is, that the aspect of the heavens at any particular hour of the day, reckoned in mean solar time, varies at different times of the year; for those stars which at one time are seen on the meridian at midnight, pass it at 9^h in the evening after about 6 weeks.

The clocks we have in common use are all regulated to mean time, and will therefore show 12 o'clock sometimes before and sometimes after the true Sun has reached the meridian: this difference between mean time and apparent time is called the *Equation of Time*, and Tables are constructed for the purpose of reducing the one to the other. Four times a year, the correction is zero, and the true and imaginary Suns coincide. Twice in the same period the clock is before the Sun, and twice after it. The equation reaches its maximum about Feb. 10, when a correction of about 14^m 28^s is required to reduce apparent to mean solar time; or, in other words, the mean sun is on the meridian 14^m 28^s before the true Sun. On April 15 there is no equation, the real and fictitious Suns being on the meridian at the same moment. Towards the middle of May the equation again reaches a maximum of 3^m 53^s, but becomes reduced to zero by June 15. Another maximum occurs about July 27, when a correction of 6^m 14^s must be added to the apparent solar time. On Sept. 1 the equation is again at zero, but increases from that time until the beginning of November, when the correction amounts to 16^m 18^s, subtractive from apparent time. Another zero takes place about Dec. 25, and this completes the circuit.

In France, until 1816, apparent time was used, and the confusion arising from this practice may be readily imagined. Arago relates that he was once told by Delambre that he had frequently heard the different public clocks striking the same hour with a variation of 30 minutes. At the time of the change, the Prefect of the Seine refused to sign the necessary order, fearing an insurrection amongst the lower classes; the worthy magistrate's fears however proved to be groundless. Especially were the watchmakers thankful for the change; under the old

EQUATION OF TIME AT APPARENT NOON.

Day of Month.	January.	February.	March.	April.	May.	June.	July.	August.	September.	October.	November.	December.
	+ m. s.	+ m. s.	+ m. s.	+ m. s.	- m. s.	- m. s.	+ m. s.	+ m. s.	- m. s.	- m. s.	- m. s.	- m. s.
1	3 51	13 51	12 32	3 55	3 3	2 30	3 29	6 4	0 6	10 18	16 17	10 46
3	4 47	14 6	12 7	3 19	3 16	2 11	3 52	5 56	0 44	10 56	16 18	9 59
5	5 42	14 16	11 41	2 44	3 28	1 50	4 14	5 45	1 23	11 32	16 16	9 11
7	6 35	14 24	11 12	2 9	3 38	1 29	4 34	5 32	2 3	12 7	16 11	8 20
9	7 25	14 28	10 42	1 36	3 45	1 6	4 53	5 17	2 44	12 41	16 2	7 27
11	8 14	14 29	10 11	1 3	3 50	0 43	5 10	4 59	3 26	13 12	15 50	6 32
13	9 0	14 27	9 38	0 31	3 53	0 18	5 25	4 39	4 8	13 42	15 34	6 36
15	9 43	14 22	9 4	0 0	3 53	0 6	5 38	4 17	4 50	14 9	15 15	4 38
17	10 23	14 14	8 29	0 29	3 52	0 32	5 49	3 52	5 33	14 34	14 53	3 40
19	11 1	14 3	7 53	0 56	3 48	0 58	5 58	3 26	6 15	14 57	14 27	2 40
21	11 36	13 50	7 17	1 22	3 41	1 24	6 5	2 58	6 57	15 17	13 58	1 40
23	12 7	13 34	6 41	1 46	3 33	1 50	6 10	2 28	7 39	15 34	13 25	0 40
25	12 36	13 15	6 4	2 8	3 22	2 15	6 13	1 56	8 20	15 49	12 50	0 19
27	13 1	12 55	5 27	2 28	3 9	2 41	6 14	1 23	9 0	16 1	12 11	1 19
29	13 24		4 50	2 47	2 55	3 5	6 12	0 48	9 40	16 9	11 30	2 18
31	13 43		4 14		2 38		6 7	0 12		16 15		3 16

system, all in vain was it that they tried to explain to their enraged customers, when they came to complain of the watches they had bought, that it was not the watches but the Sun which was in fault.

The interval of time which elapses from the moment when the Sun leaves a fixed star until it returns to it again, constitutes the *sidereal year*, and consists in solar time of $365^{\text{d}} 6^{\text{h}} 9^{\text{m}} 9.6^{\text{s}}$; therefore the sidereal year is longer than the mean solar year. The latter is the interval of time which elapses between 2 successive passages of the Sun through the same equinox. If the equinoxes were fixed points, then this period would be identical with the sidereal revolution of the Earth; but since these points are possessed of a retrograde motion from East to West of $50.27''$ annually, it follows that the Sun returns to the equinox sooner every year by a period equal to the time which it takes to traverse $50.27''$ of arc, or by $20^{\text{m}} 22.9^{\text{s}}$ of time. The mean solar year is therefore $20^{\text{m}} 22.9^{\text{s}}$ shorter than the sidereal year, or its length is $365^{\text{d}} 5^{\text{h}} 48^{\text{m}} 46.7^{\text{s}}$. In consequence of lack of uniformity in the motion of the equinoctial points (on account of planetary perturbation), a variation takes place in the length of the mean solar year, which is now diminishing in length at the rate of 0.595^{s} per century. This variation, however, will not always be in operation.

The line of apsides of the Earth's orbit is subject to an annual progressive motion of $11.778''$ (Delambre). If the Earth, then, be supposed to start from perihelion, it will require a longer interval of time than the sidereal period to reach perihelion again, and the excess will be equal to the time necessary for the Earth to describe $11.8''$ of its orbit; this it would do in $4^{\text{m}} 39.7^{\text{s}}$, which quantity must be added to the sidereal period before we can ascertain the interval between 2 successive returns to perihelion. The result then is a period of $365^{\text{d}} 6^{\text{h}} 13^{\text{m}} 49.3^{\text{s}}$ (365.2595981 mean solar days), which is called the *anomalous year*.

The manner in which the ancients ascertained the length of the year was by means of the *gnomon* or *stylus*—a vertical rod

standing on a smooth plane which had a meridian line described on it. The time when the shadow was shortest would indicate the day of the summer solstice, and the number of days which elapsed until the shadow returned to the same length would be the number of days in the year. This interval having been found to be 365 days, 365 days was the period adopted for the length of the common year, or nearly 6 hours less than the true length. Such a difference would, after the lapse of some time, throw everything into confusion; for, supposing that in any one year the summer solstice fell on June 21, after the lapse of 4 years it would fall on the 22nd, in another period of 4 years it would happen on the 23rd, and so on. Some inhabitant of Thebes in Egypt is said to have been the first to have noticed the necessity of an addition of 6 hours to the 365 days in order to make the year coincide with the annual course of the Sun. In the time of Democritus (450 B.C.), $365\frac{1}{4}$ days was supposed to be the length of the year; Eudoxus made it somewhat longer, and, according to Diodorus Siculus, Cœnopides of Chios fixed it at $365^d 8^h 48^m$. Hipparchus, by means of his own observations, found the length then in use ($365\frac{1}{4}$ days) to be too great by $4^m 48^s$. Ptolemy also examined the subject, but came to no definite determination. Towards the close of the 9th century, the Arabian prince Albategnius, from observations of his own, considered that the length given by Hipparchus was still too great by some $8^m 48^s$; he accordingly assigned a new determination in his work, *De Scientiâ Stellarum*. The following table exhibits some of the principal determinations which have been arrived at, both in ancient and modern times:—

	d.	h.	m.	s.
Ancient Egyptian
Euctemon and Meton
Calippus, &c.
Hipparchus
Hindu
Albategnius
Alphonsine Tables, 1252
Walther
Copernicus, 1543

	d.	h.	m.	s.
Tycho Brahe, 1602	365	5	48	45 $\frac{1}{2}$
Kepler	365	5	48	57 \cdot 6
J. Cassini, 1743	365	5	48	52 \cdot 4
Flamsteed	365	5	48	57 \cdot 5
Halley	365	5	48	54 \cdot 8
La Caille	365	5	48	49
Delambre	365	5	48	51 \cdot 6
Laplace	365	5	48	49 \cdot 7
Bessel	365	5	48	47 \cdot 8
Hansen and Olufsen	365	5	48	46 \cdot 15
Le Verrier...	365	5	48	46 \cdot 05

We have seen that the mean solar year does not contain a whole number of days, but that a fractional quantity is appended; that is to say, its length is thus expressed— $365^{\text{d}}2422414$ days. 100 years of 365 days each would contain 36,500 days, or would fall short of 365 revolutions of the Sun by about 24 days. In order to remedy this state of things, Julius Cæsar, who was as distinguished for the varied nature of his mental attainments as for his skill in military affairs, called to his aid the Egyptian astronomer Sosigenes, and they both set to work to reform the calendar. They introduced an additional day every 4th year into the month of February, thereby making 25 additional days in the century. This 4th year was termed *bissextile*, because the 6th day before the calends of March was reckoned twice, and in this year, therefore, February was made to consist of 29 days. This almost perfect arrangement, which was called from its author the Julian style, prevailed generally throughout the Christian world till the close of the 16th century^b. The calendar of Julius Cæsar was defective in this particular,—that the solar year consists of $365^{\text{d}}5^{\text{h}}48^{\text{m}}\frac{3}{4}$, and not of $365^{\text{d}}6^{\text{h}}$, as was supposed in his time, and therefore there was a difference of 11^{m} between the apparent and true years. At the time of Gregory XIII. this difference had so accumulated as to amount to more than 10 days, the vernal equinox falling, in 1582, on March 11 instead of 21, at which it was in the year 325 A.D., when the Council of Nicæa was held. At this Council uniformity in the keeping of Easter

^b The Julian error amounted to $+0\cdot00778$ day annually, or 1 whole day in 129 years.

was decreed, and the first Sunday after the first full Moon next following the vernal equinox became tacitly recognised. "As certain other festivals of the Romish Church were appointed at particular seasons of the year, confusion would result from such want of constancy between any fixed date and a particular season of the year. Suppose, for example, that a festival, accompanied by numerous religious ceremonies, was decreed by the Church to be held at the time when the Sun crossed the equator in the spring (an event hailed with great joy as the harbinger of the return of summer), and that in the year 325, March 21 was designated as the time for holding the festival, since at that period it was on March 21 when the Sun reached the equinox; the next year the Sun would reach the equinox a little sooner than the 21st, only 11^m indeed, but still amounting to 10 days in 1200 years; that is, in 1582 the Sun reached the equinox on March 11. If, therefore, they continued to observe the 21st as a religious festival in honour of this event, they would commit the absurdity of celebrating it 10 days after it had passed by." This anomaly Gregory XIII. undertook to correct, and this he did with practically perfect success; he ordained that 10 days should be left out of the current year in order to bring back the equinox to March 21, and in order to keep it on that day, he prescribed the following rule:—*Every year, not being a secular year, divisible by 4, to be a bissextile, or leap year, containing 366 days: every year not so divisible to consist of only 365 days: every secular year divisible by 400 (such as 1600, 2000, &c.), to be a bissextile, or leap year, containing 366 days: every secular year not so divisible (such as 1800, 1900, &c.) to consist of 365 days.* If every 4th year were to consist of 366 days, a century would be too long by $\frac{1}{4}$ of a day: that is to say, we should have allowed 1 whole day in 100 years instead of only $\frac{3}{4}$; in 400 years this would have amounted to 1 day; this will explain why a day is to be intercalated every 4th secular year, the other secular years containing only 365 days. We will now perform some short calculations to see how near this rule is to the truth, by comparing 10,000 Gregorian with 10,000 Tropical (or solar) years.

In 10,000 the numbers not divisible by 4 will be $\frac{3}{4}$ of 10,000, or 7500; those divisible by 100, but not by 400, will in like manner be $\frac{3}{4}$ of 100, or 75; so that in the 10,000 years in question, 7575 consist of 365 days, and the remaining 2425 of 366, producing in all 3,652,425 days. Dividing this number by 10,000, we get 365.2425 as the mean Gregorian length of the solar year. The actual value of the latter being 365.24224, the error in 10,000 years amounts to 2.6, or $2^d 14^h 24^m$, or 1 day in 3846 years, or 22^s annually—a quantity which we can, without inconvenience, disregard^c. But even this error, trifling as it is, may be still further eliminated by declaring those years divisible only by 4000, to be common and not bissextile years; this would make the error only 1 day in 100,000 Gregorian years.

The Gregorian remedy was proposed by Cardinal Pierre D'Ailly to the Council of Constance, and to Pope John XXIII. as early as 1414. About the same time Cardinal Cusa wrote on the subject. Roger Bacon had previously made a formal proposition relating to it. Sextus IV. being desirous of realising the plan, called to his court Regiomontanus, and made him Archbishop of Ratisbon, but the death in 1476 of this astronomical prelate prevented progress. When the Council of Trent separated in 1563 it recommended the Pope to take up the matter^d.

The Julian calendar was introduced in the year 44 B.C., which Cæsar ordered should commence on Jan. 1, being the day of the New Moon immediately following the winter solstice of the preceding year: this year was thus made to consist of 445 days, and was known as "the year of confusion." Cæsar did not live to carry out in person the reform he had decreed, and the consequence was that real and great confusion ensued. We are not acquainted with the terms of the edict which he promulgated, but we are led to infer that it was not so explicit as it ought to have been, and that it contained some expressions relating to "every 4th year" which were not clearly enunciated. The

^c Hansen's investigations (*Tables du Soleil*, p. 1) imply the necessity of revising to a trifling extent these figures,

but I have not deemed it worth while to do this for my present purpose.

^d Arago, *Pop. Ast.*, vol. ii. p. 744.

consequence was, that Cæsar's successors counted the year just elapsed as No. 1 of the quadrennial period, and intercalated every *third* instead of every 4th year. "This erroneous practice continued during 36 years, in which, therefore, 12 instead of 9 days were intercalated, and an error of 3 days produced; to rectify which Augustus ordered the suspension of all intercalation during three complete *quadrennia*,—thus restoring, as may be presumed his intention to have been, the Julian dates for the future, and re-establishing the Julian system, which was never after vitiated by any error till the epoch when its own inherent defects gave occasion to the Gregorian reformation. . . . And starting from *this* [the period of the Augustan reform] as a certain fact, (for the statements of the transaction by classical authors are not so precise as to leave *absolutely no doubt* as to the previous intermediate years), astronomers and chronologists have agreed to reckon backwards in unbroken succession on this principle, and thus to carry the Julian chronology into past time, *as if* it had never suffered such interruption, and *as if* it were certain [which it is not, though we conceive the balance of probabilities to incline that way] that Cæsar, by way of securing the intercalation as a matter of precedent, made his initial year, 45 B.C., a leap year. Whenever, therefore, in the relation of any event, either in ancient history or in modern, previous to the change of style, the time is specified in our modern nomenclature, it is always to be understood as having been identified with the assigned date by threading the mazes (often very tangled and obscure ones) of special and national chronology, and referring the day of its occurrence to its place in the Julian system *so interpreted*°." The reformed Gregorian calendar was published to the world in 1582, the Pope at the same time issuing a decree commanding its observance throughout Christendom. His mandate met with great opposition from those Catholic powers of Europe which did not recognise the Papal supremacy; but in Romish countries it was soon adopted. It was not established in Great Britain till 1752, when an Act of Parliament was

° Herschel, *Outlines of Ast.*, p. 675.

passed enjoining its use^f. As 170 years had elapsed since the new style had been first brought into use, it became necessary to suppress 11 days, in order to set right the equinox; this was effected by calling the day after Sept. 2 the 14th. By the same Act it was decreed that Jan. 1 should be the commencement of the year, instead of March 25, as it had been heretofore. We shall now see the practical effect of these changes. In order to make any date given in the o.s. comparable with our present mode of reckoning, we must add thereto 11 days: thus, April 24 o.s. is equivalent to May 5 N.S. If any event happened between Jan. 1 and March 25, the date of the year will be advanced 1: thus, March 21 1890 o.s. will be April 2 1891 N.S.; bearing in mind that the difference between the two styles, which in 1752 was 11 days, is now 12. Russia and the Greek Church generally still adhere to the old style, consequently their dates are thus expressed:—

$$1890 \frac{\text{May } 23.}{\text{June } 4.}$$

A sweeping change such as was involved in this Gregorian revision was, as might have been anticipated, received with great dissatisfaction by the English nation at large, but more especially by the lower orders, who considered that they had been robbed of 11 clear days. The inconveniences to which everybody was subjected (because every kind of festival and anniversary was disturbed) were, moreover, by no means agreeable to the feelings of most people. Professor De Morgan, on the authority of a scientific friend, related the following anecdote:—"A worthy couple in a country town, scandalised by the change of style in 1752, continued for many years to attempt the observance of Good Friday on the old day. To this end they walked seriously and in full dress to the church door, at which the gentleman rapped with his stick; on finding no admittance, they walked as

^f 24 Geo. II. c. 23. It is not generally known that an effort was made to reform the Calendar as early as the reign of Queen Elizabeth. On March 16, 1584-5, a bill was introduced into the House of

Lords for the purpose. It was read a second time on March 18, and then appears to have been dropped, as we have no further notice of it. (*Eng. Cycl.*, art. "Kalendar.")

seriously back again, and read the Service at home. But on the new and spurious Good Friday they took pains to make such a festival at their house as would convince the neighbours that their Lent was either ended or in abeyance." But there must have been some days of comfort, for between 1752 and 1800 there were 18 years in which the old and new Easter Day coincided. This happens occasionally, and will continue to do so, though less and less frequently, till 2698 A. D., when it will occur for the last time.

Previous to the change of style there existed a wide-spread superstition in England that, at the moment when Christmas Day began, the cattle always fell on their knees in their stables; it was averred, however, that the animal creation refused to obey the Papal bull, and still continued their prostrations on the Christmas eve of the Old Style. In Romish countries, however, even inanimate things agreed to change their habits; for Riccioli positively assures us that the blood of St. Januarius, which under the old order of things always liquefied punctually on Sept. 19 (?), immediately changed its day of liquefaction to Sept. 9, o. s., in order to conform to Sept. 19, n. s., thereby putting itself back 10 days, that it might obey the Pope's mandate! But this was not all; for Riccioli goes on to add that a certain twig, which always budded on Christmas Day, o. s., thenceforth budded on Dec. 15, o. s., for the same reason^g!

In England the members of the Calendar-Reforming Government were pursued and mobbed in the streets of London, the populace demanding the restoration of the 11 days of which they supposed they had been illegally deprived.

On the subject of the Calendar generally some useful information will be found in the work cited below^h.

^g *Companion to the Almanac*, 1845, p. 19.

^h *Astronomy without Mathematics*. By Lord Grimthorpe. The Theory of the

Equation of Time is very clearly explained in Linnington's *Compendium of Astronomy*, p. 231.

CHAPTER II.

SUB-DIVISIONS OF TIME.

Hours.—Commencement of the days.—Usage of different nations.—Days.—Weeks.—Origin of the English names for the days of the week.—The Egyptian 7-day period.—The Roman week.—Months.—Memoranda on the months.—Years.—The Egyptian year.—The Jewish year.—The Greek year.—The Roman year.—The Roman Calendar and the reforms it underwent.—The French revolutionary Calendar.—The year.—Its sub-divisions into quarters.—Quarter days.

WE have now to consider the different divisions of time which are in use, beginning with—

Hours.—I have already mentioned that a day is divided into 24 equal portions, called hours; each of these contains 60 minutes, and each minute 60 seconds^a. It is now quite impossible to assign any date to the origin of this custom, so completely is it lost in the obscurity of antiquity. Although the duodecimal division of the day is so universal, yet different usages have prevailed in different countries relative to the enumeration of those hours. Some nations have counted the hours consecutively from 1 to 24; others have divided the hours into 2 series of 12 each; whilst in France, during the revolutionary period following the year 1793, a decimal system was introduced, the day being divided into 10 hours, each hour into 100 minutes, and each minute into 100 seconds. After the lapse of a few years, however, this, together with many other equally absurd innovations, was given up.

The 24 hours into which the day is divided were usually intended to be equal, each comprising $\frac{1}{24}$ part of the whole; but

^a The old sub-divisions of thirds and fourths have entirely fallen into disuse, every odd part of a second being ex-

pressed decimally. Thus: 13^h 17^m 24^s 18^t 13^f would now be expressed as 13^h 17^m 24^s 303^a.

there were exceptions to this. For instance, at one period in the history of Greece the interval between sunrise and sunset was divided into 12 equal portions, termed "hours of the day;" the other interval between sunset and sunrise being also similarly divided into the "hours of the night." It is clear that it is only at the equinoxes that the former would be equal to the latter, that from the vernal to the autumnal equinox the diurnal hours would be the longest, and that during the rest of the year the nocturnal hours would be the longest. A variation in the length of each also took place from day to day. Such a system, inconvenient as it doubtless was for the ordinary affairs of life, was positively useless for all scientific purposes; hence we find that Ptolemy was in the habit of transforming these common hours into equinoctial hours—so called, probably, because at the equinoxes they were equal in duration to the vulgar hour. Even with this improvement we find that that distinguished astronomer was unable to indicate the time of any celestial phenomenon within a quarter of an hour of its true time. This conclusively shows us the imperfections of the chronometric appliances then in use: we are now able to obtain observations within $\frac{1}{10}$ of a second of the absolute truth^b.

Having determined on the unit which we propose to employ as a chronometric register, it is also necessary to determine conventionally some particular moment when each successive unit shall commence and end. The Jews, the Chinese, the ancient Athenians, and Oriental nations, and the Italians in past times^c, fixed upon sunset as the termination of one day and the commencement of the following, counting the hours from 0 to 24.

^b An interesting instance of the surprising accuracy now attainable in astronomical observations was afforded by the occultation of the planet Saturn by the Moon on May 8, 1859. The phenomenon was watched at the Greenwich Observatory by 5 persons, with different telescopes, and the following are the times of disappearance recorded by them:

	h.	m.	s.
Rev. R. Main	8	19	42·4
Mr. Glaisher	8	19	42·5

	h.	m.	s.
Mr. Dunkin	8	19	42·6
Mr. Ellis	8	19	42·9
Mr. Criswick	8	19	42·2

Month. Not., vol. xix. p. 238. May 1859.

^c In a letter to the *Times* (Dec. 5, 1884) General E. Strachey notes that the 24-hour day, reckoned from $\frac{1}{2}$ an hour after sunset, still exists in Rome, Naples, and other parts of Italy. A change of initial hour was made not daily, but only once a week or so.

As the hours of sunrise and sunset vary from day to day, it is manifest that 4 o'clock one day will not be the same as 4 o'clock the day previously; so that for a clock to indicate such time it must be set from day to day, or from week to week, since the hour of sunset will be constantly later during one half year, and earlier during the other. This system of reckoning has been defended upon the ground of the convenience it affords to travellers and others, in telling them, without trouble, how much time is left at their disposal before nightfall. This is no doubt perfectly correct, as far as it goes; but then, on the other side of the question, the constant necessity of setting the clocks every day has to be considered, to say nothing of the other "obvious inconveniences attending such a system, such as the constant variation of the hours of meals, of going to bed and rising, of all description of regular labour, the hours of opening and closing all public offices, of commencing and terminating all public business," &c. Notwithstanding all this, however, the force of habit is so strong that this system was until lately in use in Italy; though in many places it was customary to set up 2 clocks side by side, one indicating Italian and the other common time. This system, with the unimportant modification of starting from *sunrise*, was also used by the Babylonians, Assyrians, and Persians, and is at the present time adopted by the modern Greeks and the inhabitants of the Balearic Islands. A curious custom of keeping the clocks 1^h in advance of the true time formerly existed at Basle^d.

Hipparchus adopted the plan of commencing the day at midnight, and dividing it into 2 equal series of 12 hours each: this system was followed by Copernicus, and is now in general use throughout all civilised parts of the globe. According to this mode of reckoning, whenever an hour is named, it is requisite to state the position in which it stands as regards noon. The hours previous to noon are indicated by the letters A.M., and those after noon by P.M.—the former being the initial letters of the Latin words *ante meridiem* ("before mid-day"), and the latter

^d See Murray's *Handbook for Switzerland*, p. 4.

of *post meridiem* ("after mid-day"). The ancient Egyptians commenced their day with the Sun's passage over the meridian; in this they were followed by Ptolemy and by astronomers in modern times, who divide the day into 24 hours. In dealing with times mentioned in connection with astronomical matters we must therefore carefully distinguish between civil and astronomical time, the former being 12 hours ahead of the latter.

Days.—A day is the standard unit of measurement now universally adopted, all shorter intervals of time being reckoned by some of its fractional subdivisions, and all longer intervals by some or other multiple of it. However, after what has been said in the previous chapter, it is unnecessary to dwell further on the 'day' here.

Weeks.—The historical origin of the well-known period of 7 days is quite lost in antiquity^e, and though some difference of opinion may exist as to the prevalence of it in early times as a mode of reckoning, it must undoubtedly be regarded as a memorial of the Creation of the world, reference being made to it in the account of that event handed down to us in the Book of *Genesis*^f. It is also an obvious and convenient subdivision of the lunar month, besides being so nearly an exact aliquot part of a solar year of 365 days ($7 \times 52 = 364$)—two good reasons for its adoption.

The English names of days of the week are derived as follows:—

^e Laplace's observations on this are very striking, the more so when we consider the times he lived in and the Infidel views as to religion which he held during most of his life:—"The week from the very highest antiquity, in which its origin is lost, has, without interruption, run on through ages, uniting itself with the successive calendars of different nations. . . It is perhaps the most ancient and most incontestable monument of human intelligence, and appears to indicate that all such intelligence came from one common source." (*Exposition du Système*

du Monde, vol. i. p. 32.)

^f "Here seems to be an evidence that the days of the Creation are not figurative but literal days; and this appears to be clearly stated in Ex. xx. 11. . . . A particular day was set apart by God to commemorate His rest on that day, and was observed by His people at His command; and if the seventh of this series of days was a real physical day, the other six were also real days, and not figurative: they were not periods, but days." —Bp. Wordsworth, *Comment. on the Bible*. Gen. ii. 3.

1. Sonen daeg (Sax.), Sun's day	whence Sunday.
2. Monan daeg (Sax.), Moon's day	„ Monday.
3. Tiues daeg (Sax.), Tiu's day	„ Tuesday.
4. Wodnes daeg (Sax.), Woden's day	„ Wednesday.
5. Thunres daeg (Sax.), Thor's day	„ Thursday.
6. Friges daeg (Sax.), Friga's day	„ Friday.
7. Saeters daeg (Sax.), Saturn's day	„ Saturday.

In many Parliamentary and judicial documents the Latin names were retained until quite recently; the Quakers, however, do not use either, but call Sunday the 1st day of the week, Monday the 2nd, and so on. The reason why the 1st day of the week is kept as the Christian Sabbath is that the Resurrection of our Lord took place on that day, and it was accordingly determined that the day for the observance of the Sabbath should be changed, to symbolise the displacement of the Primæval by the Christian dispensation, for, be it understood, the principle involved in the Sabbath is the consecration to God of one day in seven, not of any one particular day of the week, and this principle dates not from the time of Moses, but from that of Adam.

Dion Cassius (Consul, A.D. 229) ascribes the use of a 7-day period to the Egyptians, and states that from them it was copied in after times by the Greeks and other nations. He makes some curious remarks on the manner in which the Egyptians derived the names of the days of the week and their order from the 7 members of the solar system known to the ancients^g.

The following were the Roman names of the days of the week, the order of sequence being derived from the Egyptians:—

1. Dies Saturni	Saturn's Day.
2. Dies Solis	Sun's Day.
3. Dies Lunæ	Moon's Day.
4. Dies Martis	Mars's Day.
5. Dies Mercurii	Mercury's Day.
6. Dies Jovis	Jupiter's Day.
7. Dies Veneris	Venus's Day.

From the above have been derived the modern names used in the different countries of Europe, either by a literal translation as in the Italian, French, Spanish, and other languages of Latin

^g *Hist. Roman.*, lib. xxxvii. 19.

origin, or, as in the Teutonic languages, by a substitution for the name of the classical, of that of the corresponding Teutonic deity.

Months.—The relation of this division of time to the Moon is singularly apparent in many languages, notwithstanding that the Moon's period of revolution is unsuitable as a measure of time, both on account of its not being marked by any easily-observed phenomena and also because it is neither a multiple of a day nor an aliquot part of a year. The lunar month, however, has been used by the inhabitants of many of the more interesting and important countries of the Earth.

A few memoranda on the months as they now stand may be useful. Every one is familiar with the following lines. I now quote from a version published in 1596 :—

“Thirtie daies hath September,
 Aprill, June, and November,
 Februarie hath eight and twentie alone,
 All the rest thirtie and one.
 Except in Leap year, at which time
 Februarie's daies are twentie and nine.”

To find the day of the month without an Almanac, it may be useful to know that except in leap years the following are all of the same name :—

1st of January, October.
 2nd of April, July.
 3rd of September, December.
 4th of June.
 5th of February, March, November.
 6th of August.
 7th of May^h.

The common year begins and ends on the same day of the week: leap year ends on the following day. Many persons who speak of the year as consisting of 52 weeks are not aware that it is always 52 weeks 1 day long, and in leap year 52 weeks 2 days long.

A nation possessed of 2 such well-defined chronometric units as the solar day and year would doubtless soon find the incon-

^h A versification of this appears in the *Eng. Cycl.*, art. “Year.”

venience of not having some period intermediate between them. Let us now see what intermediate subdivisions there are which would answer the purpose. A year does not contain any exact number of days—it contains $365\frac{1}{4}$ (nearly), but since the ancients reckoned it at 365 exactly, we will do the same. Now it is clear that the only factors of 365 are 5 and 73; and we must, therefore, either divide the year into 5 equal periods of 73 days each, or 73 equal periods of 5 days each. That neither of these subdivisions will meet the requirements of mankind we have an intimation in the fact that during more than 5000 years neither of them has ever been adopted. No other equal subdivision of the year being possible, some different plan must be devised; we may either divide the year into a certain number of equal parts, with a remainder, and then consider the remainder as a supplemental part; or we may resolve the year into some convenient number of unequal parts.

The Egyptian year was arranged according to the 1st of these plans, and was divided into 12 months, each of 30 days, with 5 days added at the end of the 12th month.

The Jewish year is regulated according to the 2nd expedient. The following are the months:—

	Days.		Days.
Nisan	30		Tisri 30
Ijar	29		Marchesvan ... 29 or 30
Sivan	30		Kislev 29 or 30
Thamuz	29		Tebeth 29
Ab	30		Schebat 30
Elul	29 or 30		Adar 29
			Veadar (intercalary) 29

The division of the year into months by the ancient Greeks was not only very unmethodical, but it would seem that no 2 States agreed either in the number, names, or lengths of their months. Some months were designated by particular names, while others were known only by the numerical order in which they followed one another. These numbers, however, did not correspond in different States on account of the year beginning at different times. The confusion arising from such a state of

things in a small country, inhabited by one nation speaking one language, may be readily imagined.

Notwithstanding the advanced civilisation of the Romans, it was not till 700 years after the foundation of their city that they became possessed of a properly arranged system of reckoning. The year, as established by Romulus, contained 304 days portioned off into 10 months.

It was soon found that a year of 304 daysⁱ was irreconcilable with the nature of things; and accordingly we find that in the following reign, that of Numa Pompilius, 2 new months were added, Februarius and Januarius. The latter was placed at the beginning, and the former at the end of the year; this arrangement was however afterwards altered, and Januarius made to precede Februarius, leaving Martius the 1st month of the year. This will account for the fact that September and the 3 following months bear names which do not correspond to the places which they now occupy. In order to make the year correspond with tolerable accuracy to the true solar year, Numa resolved on increasing its length by 51 days, and the months were then arranged as follows:—

	Days.	Days.
Januarius	29	Quintilis (afterwards Julius) 3 ¹
Februarius	28	Sextilis (afterwards Augustus) 29
Martius	31	September 29
Aprilis	29	October 3 ¹
Maius	31	November 29
Junius	29	December 29
		—
		355

Januarius derived its name from Janus, the deity who presided over doors and other things. Februarius from *februare*, to expiate, it being customary this month to perform certain ceremonies of purifications. Martius from Mars, the god of War, and father of Romulus. Aprilis from Aphrodite^j. Maius from Maia^k, the mother of Mercury. Junius from Juno^k,

ⁱ Sir G. C. Lewis considered this 304-day year to be altogether a myth. *Ast. of Ancients*, p. 56.

anything to do with *aperire*, to open, is destitute of foundation. See Chambers's *Book of Days*, vol. i. p. 456.

^j The idea that the word April has

^k *Sed quare?*

Queen of Heaven. The names of the months Quintilis and Sextilis were afterwards changed in compliment to the emperors Julius Cæsar and Augustus Cæsar.

Notwithstanding the modifications introduced by Numa, the year was still 10 days too short; to correct this he decreed that a 13th, or intercalary, month should be introduced every other year, consisting of 22 or 23 days.

The days of the Roman month were reckoned in the following way: the 1st day of each month was called the *kalends*^k; the 7th day of each of the 4 great months (those of 31 days), and the 5th of each of the lesser months (those of 29 days), were called the *nones*; and the 15th of all the great months, and the 13th of all the lesser months, were called the *ides*. The *nones* were so called as being on the 9th day before the *ides* reckoned inclusively. The word *ides* was derived from the root *id-* which appears in the Latin verb *divido*, and the word signifies the day on which (roughly speaking) the month is divided. The difference in the positions of the two kinds of *nones* and *ides* is owing to the Roman custom of reckoning time backwards.

As frequent allusion is made in classical and other writers to the Roman mode of computation, it may be useful to subjoin the table on the opposite page.

The Mahometan year is a lunar one, consisting of 12 months, of 30 and 29 days alternately, each of which begins with the first appearance of the New Moon, without any intercalation to bring the year to the same season. It is obvious, therefore, that every year will begin earlier than the preceding one by about $11\frac{1}{4}$ days. The inconveniences to which this gives rise have already been pointed out. It moreover happens that as the commencement of each month depends on the first visibility of the New Moon, a few cloudy days will produce serious confusion, as it will lead to differences of sometimes a day or two in the reckoning in parts of the country widely separated from each other^l.

^k This word, not being used by the Greeks, gave rise to the saying, that such and such a thing was postponed to the Greek *kalends*; *sine die*, as we should say.

^l An exhaustive account of the Mahometan calendar will be found in the *Conn. des Temps*, 1844, p. 111. The Persians have a different calendar.

THE ROMAN CALENDAR.

Dies Mensis.	April. Sept.	Jun. Nov.	Jan. Decemb.	Aug.	Mar. Jul.	Mai. Octob.	Feb.
1	KALENDÆ.		KALENDÆ.		KALENDÆ.		KALENDÆ.
2	IV.		IV.		VI.		IV.
3	III.		III.		V.		III.
4	Prid. Non.		Prid. Non.		IV.		Prid. Non.
5	NONÆ.		NONÆ.		III.		NONÆ.
6	VIII.		VIII.		Prid. Non.		VIII.
7	VII.		VII.		NONÆ.		VII.
8	VI.		VI.		VIII.		VI.
9	V.		V.		VII.		V.
10	IV.		IV.		VI.		IV.
11	III.		III.		V.		III.
12	Prid. Id.		Prid. Id.		IV.		Prid. Id.
13	IDUS.		IDUS.		III.		IDUS.
14	XVIII.		XIX.		Prid. Id.		XVI.
15	XVII.		XVIII.		IDUS.		XV.
16	XVI.		XVII.		XVII.		XIV.
17	XV.		XVI.		XVI.		XIII.
18	XIV.		XV.		XV.		XII.
19	XIII.		XIV.		XIV.		XI.
20	XII.		XIII.		XIII.		X.
21	XI.		XII.		XII.		IX.
22	X.		XI.		XI.		VIII.
23	IX.		X.		X.		VII.
24	VIII.		IX.		IX.		VI.
25	VII.		VIII.		VIII.		V.
26	VI.		VII.		VII.		IV.
27	V.		VI.		VI.		III.
28	IV.		V.		V.		Prid. Kal. }
29	III.		IV.		IV.		Martii. }
30	Prid. Kal.	}	III.	}	III.	}	
31	mensis seq.		Prid. Kal.		mensis seq.		Prid. Kal.

One other system may be noticed. In 1792, the French nation, in its excessive desire to sweep away every vestige of monarchy and of the existing institutions of the country, determined on adopting a new calendar, founded on very novel principles; but finding that it was unable to produce any plan more accurate or convenient than the one in previous use, it only made some minor alterations. The first year of the new Republican era commenced on Sept. 22, 1792 (N.S.), the day of the autumnal equinox. The year consisted of 12 months of 30 days each, with 5 supplementary ones kept as festivals. Every 4th year was a leap year, but called by the demagogues a Franciad or Olympic year. The months were as follows^m :—

Vendémiaire	Vintage Month, commenced Sept. 22.
Brumaire	Foggy ,, ,, Oct. 22.
Frimaire	Sleety ,, ,, Nov. 21.
Nivôse... ..	Snowy ,, ,, Dec. 21.
Pluviôse	Rainy ,, ,, Jan. 20.
Ventôse	Windy ,, ,, Feb. 19.
Germinal	Budding ,, ,, Mar. 21.
Floréal... ..	Flowering ,, ,, April 20.
Prairial	Pasture ,, ,, May 20.
Messidor	Harvest ,, ,, June 19.
Thermidor	Hot ,, ,, July 19.
Fructidor	Fruit ,, ,, Aug. 18.

The Festivals, or *Jours Complémentaires*, were the 5 days from Sept. 17–21, which were dedicated to “Virtue,” “Genius,” “Labour,” “Opinion,” “Reward,” respectively.

The bissextile day, intercalated every fourth year, was called *Le Jour de la Révolution*, and was set apart for the renewal of the oath to live free or die! Not content to rest here, these misguided men abolished the week, and divided the month into 3 decades, the days of which were named Primidi, Duodi, Tridi, Quartidi, &c.; the 10th, or Decadi, being observed as a sort of

^m An English wag composed the following paraphrase :—

Autumn.—Wheezy, sneezy, breezy;

Winter.—Slippy, drippy, nippy;

Spring.—Showery, flowery, bowery;

Summer.—Hoppy, croppy, poppy.—

Brady, *Clavis Calendaria*, vol. i. p. 38, 2nd ed. 1812.

Sabbath, though not exactly in a Christian sense of the word ! This state of things, as may be supposed, did not last long ; “for on Jan. 1, 1806, the Gregorian calendar was resumed, and the Republic, which had legislated for the 4000th year of its existence by name, wore its own livery just one day and a quarter for every one of those years.” Fabre D’Eglantine was the author of this calendar.

The whole of the decadery days were kept, or ordered to be kept, as secular festivals. The following is a list of the dedications :—

- | | |
|----------------------------------|--------------------------|
| 1. Nature and the Supreme Being. | 19. Heroism. |
| 2. The Human Race. | 20. Disinterestedness. |
| 3. The French People. | 21. Stoicism. |
| 4. The Benefactors of Humanity. | 22. Love. |
| 5. The Martyrs of Liberty. | 23. Conjugal Faith. |
| 6. Liberty and Equality. | 24. Parental Love. |
| 7. The Republic. | 25. Maternal Tenderness. |
| 8. The Liberty of the World. | 26. Filial Piety. |
| 9. The Love of our Country. | 27. Infancy. |
| 10. The Hatred of Tyrants. | 28. Youth. |
| 11. Truth. | 29. Manhood. |
| 12. Justice. | 30. Old Age. |
| 13. Chastity. | 31. Misfortune. |
| 14. Glory and Immortality. | 32. Agriculture. |
| 15. Friendship. | 33. Industry. |
| 16. Frugality. | 34. Our Ancestors. |
| 17. Courage. | 35. Posterity. |
| 18. Good Faith. | 36. Prosperity. |

“That one day in the calendar should have been appropriated to the ‘*Supreme Being*’ in conjunction with ‘*Nature*’ was a low conceit of Robespierre, who meant to identify Nature with the Supreme Being as one and the same source ; and yet even this slight remembrance of the Almighty power appears to have afforded some consolation to a great majority of the people who had not lost every sense of religion ; and to delude them with a belief of his sincerity, that arch-hypocrite himself joined in apparent devotion to *that* Almighty power whose attributes it was his real object to deride. He had even the audacious craft to decree a *fête* for the express purpose of paying *adoration* to the Deity, when for *one* day the fatal guillotine was veiled from

public view; and the better to conceal his depravity, a hideous and frightful figure, prepared for public exhibition at the festival, as the type of atheism, was previously destroyed. Part of the community, after these regulations, distinguished *Sunday* in the ancient style of festivity, whereby to *mark* the recurrence of that holy day, though no one had the temerity publicly to oppose the current of error by a more suitable observance. Many, indeed, wholly conformed to the innovation, and hence one part of the people shut up their shops on Sundays, while the *sans culotte* adherents of Robespierre rigidly observed the decadesⁿ. Robespierre artfully overcame the difficulty by decreeing that both the Sundays and the decades should be observed as festivals, thus granting to the people 83 days of recreation in the year instead of 36 or 52^o.

The year is the largest astronomical chronometric unit, and is used to express all long periods of time. It is, as I have already shown, in some form or other a derivative of the Earth's revolution round the Sun, in connection with the Moon's revolution round the Earth. Various times have been used to fix the commencement of the year; we now call Jan. 1, New Year's Day, though previous to the introduction of the new style of reckoning in 1752, the 25th of March was usually considered the 1st day of the new year. On referring to the Anglican Book of Common Prayer, it will be seen that the ecclesiastical year begins on Advent Sunday, whilst the Academical year used at the Universities begins in October. Dec. 25, March 1, Easter Day, Sept. 22, &c. have all been used at different times for the same purpose.

The year is also subdivided into 4 quarters, which point out the days on which the Sun attains its greatest Declination, North or South (called the solstices, summer and winter), and on which it is on the equator going North or South (called the equinoxes, vernal or autumnal). Owing to physical causes (already con-

ⁿ Brady, *Clavis Calend.*, vol. i. p. 35.

^o Though $36 + 52 = 88$, yet as some decades would fall on some Sundays, the

effective sum-total of the holidays would seem to have been 83.

sidered in Book III., *ante*), these events do not now take place at equal intervals, and will not do so for several thousand years to come. The following are the dates of the commencement of the seasons ^p, and their lengths, in 1860:—

	d.	h.	m.	d.	h.	m.	
Spring commences	Mar. 19	21	5	92	20	38	length of Spring.
Summer	„ June 20	17	43	93	14	9	length of Summer.
Autumn	„ Sept. 22	7	52	89	17	59	length of Autumn.
Winter	„ Dec. 21	1	51	89	1	2	length of Winter.
						365	5	48	

The following days of the year are used as quarter-days, for leases, &c., in England and Scotland:—

ENGLAND.

- March 25, or Lady-day.
- June 24, or Midsummer-day.
- Sept. 29, or Michaelmas-day.
- Dec. 25, or Christmas-day.

SCOTLAND.

- Feb. 2, or Candlemas-day ^q.
- May 15, or Whitsun-day.
- Aug. 1, or Lammas-day ^q.
- Nov. 11, or Martinmas-day.

^p The corresponding dates for 1890 are March 20^d 4^h; June 21^d 0^h; Sept. 22^d 14^h; Dec. 21^d 9^h. (*Naut. Alm.*, 1890.)

^q It has been stated that these are also used in several parts of England as days of account, but I have not been able to discover that such is the case.

CHAPTER III.

THE ALMANAC.

Means of measuring Time.—The Almanac.—Epitome of its contents.—Times of Sunrise and Sunset.—Positions of the Sun, Moon, and Planets.—The Phases of the Moon.—The Ecclesiastical Calendar.—The Festival of Easter.—Method of calculating it.

THOUGH the Creator has ordained visible objects and phenomena^a to measure the larger units of time, such as days, months, and years, He has not furnished us with any means whereby we may measure any divisions of the day such as hours, minutes, and seconds; artificial contrivances must therefore be sought for. Rough approximations to the true time were at first obtained by setting up *gnomons*, or upright staves^b; which, in conjunction with a knowledge of the North point of the heavens, would afford a tolerably correct indication of noon, or the moment of the Sun's passage over the meridian. An instrument constructed with a gnomon pointing towards the North Pole of the heavens constitutes a *sun-dial*, and affords a still better mode of ascertaining the hour of the day^c. According to Herodotus, sun-dials were first introduced into Greece from Chaldæa; the hemisphere of Berosus, who lived 540 B.C., is the oldest recorded in history^d.

The earliest attempt to form a strictly artificial time-keeper is due to Ctesibius, of Alexandria (about 250 B.C.), who invented

^a As is plainly indicated by the language employed in *Gen.* i. 14.

^b Ptolemy describes one erected at Alexandria. (*Almag.*, lib. iii. cap. 2.)

^c A very clear outline of the subject of *Dialling* (*i.e.* the construction of Sun-dials) will be found in Lockyer's

Elementary Lessons in Astronomy.

^d Described by Vitruvius, *De Architecturâ*, lib. ix. cap. 9. Stuart mentions one found on the south side of the Acropolis at Athens, which is probably of the same kind as the above. (*Antiquities of Athens*, vol. ii.)

clepsydræ, or water-clocks, which were contrivances for allowing a continuous stream of water to trickle through a small aperture in the pipe of a funnel, the time being measured by the quantity of fluid discharged^e. A species of *clepsydra*, in which mercury is employed, was introduced with great success by the late Captain Kater for the measurement of minute intervals of time by persons engaged in delicate philosophical experiments. *Sand-glasses*, still used for boiling eggs, and in the Houses of Parliament to fix the termination of the time allotted to members to prepare for a Division, are merely small *clepsydræ* in which sand is used instead of water.

All the above contrivances have now, more or less, fallen into disuse, being supplanted by the pendulum clock and the watch—into a description of which it would be foreign to my present purpose to enter^f.

Of all secular books to be found in every library, however humble, there is none of such indispensable value as the Almanac^g. One might imagine that a book so generally used by everybody would be fully understood by all; but this is by no means the case, and there are probably few things about which so much ignorance prevails, notwithstanding the frequency with which the Almanac is consulted.

The word “Almanac” (the derivation of which is uncertain^h), is applied to publications which describe the astronomical, civil, and ecclesiastical phenomena of the year. The word “Calendar” is applied, in a more limited sense, to the events of the several months, and comes from the Greek *καλέω*, I summon.

^e Vitruvius, *De Architecturâ*.

^f The newest development of mechanical science in connection with the measurement of time is the Time Gun, fired either by electricity or by the Sun's rays concentrated by means of a burning-glass. An engraving and description of the time gun of the Palais-Royal at Paris will be found in an article in *L'Astronomie*, vol. i. p. 241, September 1882. In the article in question, headed “Quelle

heure est-il,” will also be found some interesting and useful notes on the practical questions involved in the difference between solar time and mean time.

^g Much useful information about Almanacs and time generally will be found in Chambers's *Book of Days*, vol. i. p. 1.

^h Perhaps Arabic, *Al-manakh*, from a root meaning ‘to reckon.’ Arago gives as the derivation, *man*, the Moon. (*Pop. Ast.*, vol. ii. p. 721, Eng. ed.)

The astronomical phenomena which usually find a place in good Almanacs are the following:—(1) The times of Sunrise and Sunset; (2) the Right Ascension and Declination of the Sun, Moon, and principal planets; (3) the Equation of Time; (4) the times of High and Low Water; (5) the times of rising, meridian passage, and setting of the Moon; (6) the Moon's phases and age; concerning each of which a few words will here be said.

(1) If the Earth's axis were perpendicular to the plane of the ecliptic, the Sun would always (as it does now at the equinoxes) rise in the East and set in the West; but as it is inclined at an angle of about $66^{\circ} 32'$, this is not the case: and it is this inclination which gives rise to the alternation of the seasons and the ever-varying length of each successive day. It also follows from this that the hour at which the heavenly bodies rise, culminate, and set, differs on the same day at places having different latitudes or different longitudes. Celestial objects which will be visible from one place will be invisible from another. Thus the constellation of the Great Bear, which we see in England, is invisible at the Cape of Good Hope; and, conversely, the Southern Cross, which glitters in the other hemisphere, is never seen so far North as England: so that spectators in Northern latitudes look *down* (or southwards) at objects which spectators in Southern latitudes look *up* (or northwards) at, and which spectators in the Tropics see *directly over* their heads.

These circumstances must be borne in mind when we propose to ascertain beforehand the aspect of the heavens at any particular place, on any given night. From observation and theory we learn that the aspect of the heavens changes from hour to hour; and, knowing the period occupied by the Earth in her diurnal rotation and annual revolution, it becomes an easy matter to foretell, by calculation, what celestial objects will be visible at any proposed day and hour. The presence of an atmosphere around the Earth gives rise to the phenomenon of refraction¹, by which the heavenly bodies, when near the

¹ See vol. i. p. 387, *ante*.

horizon, suffer a considerable displacement, equal to about $33'$ (at the horizon), by which quantity the apparent exceeds the true altitude. Now since the diameter of the Sun is only $32'$, it follows that the Sun is elevated through a space equal to more than its own diameter; so that when we see the disc of the Sun apparently just above the horizon, the Sun itself is, in reality, just below it; and would therefore, were it not for the atmosphere, be invisible. The time of *apparent* sunrise and sunset is what is now given in our Almanacs. It is at the equinoxes only that the interval between sunrise and sunset is equal to the interval between sunset and sunrise, or that the length of the day is equal to the length of the night^k: this occurred on March 20 and Sept. 22 in the year 1890.

By reason of the fact that Civil reckoning divides the day (of 24 hours) into 2 equal portions of 12 hours each, counted from mid-night and from mid-day, a knowledge of the time of sunrise or sunset will furnish a promptly available means of determining approximately the length of the night or length of the day respectively. For instance, if the Sun rises at 5.0 A.M., 5 hours have elapsed since the previous midnight; but midnight is the mid-interval between sunset and sunrise: therefore the night is $5 \times 2 = 10$ hours long. In the same way, if the Sun sets at 7.0 P.M., the day is $7 \times 2 = 14$ hours long. Thus we arrive at 2 useful rules:—(i) *Twice the hour of sunset = the length of the day*: (ii) *Twice the hour of sunrise = the length of the night*.

(2) The Right Ascension (R.A.) of a celestial object is its distance, reckoned on the equator, from the vernal equinox, or first point of Aries, either in angular measure, of degrees, minutes, and seconds ($^{\circ}'''$); or in time, of hours, minutes, and seconds (^h ^m ^s)—24 hours making a circumference of a circle; each hour, therefore, being equal to 15° of arc. The Declination (δ) is the angular distance of a celestial object from the equator reckoned North (+), or South (−), towards the Poles. Sometimes the position of an object is indicated by its angular distance being reckoned from the North down to the South

^k This is not strictly true, but I use the term in a popular sense.

Pole: when this is the case it is indicated by the abbreviation N.P.D.—North Polar Distance.

(3) The Equation of Time has already been explained.

(4) The times of High and Low Water are usually given for the port of London; an additional constant, called the *Establishment*, being supplied, by means of which tidal phenomena at all the other ports given in the list can be readily ascertained.

(5) When the Moon, in the course of her revolution round the Earth, has the same Longitude as, and therefore passes the meridian with, the Sun, it is said to be in *conjunction* (ζ), or to be “New” (\bullet). We know that the Moon completes a mean sidereal revolution in $27^{\text{d}} 7^{\text{h}} 43^{\text{m}} 11.461^{\text{s}}$. It therefore moves round the heavens, from West to East, at the rate of $13^{\circ} 10' 35''$ (13.1764°) daily; while the Sun moves in the same direction, with a mean daily motion of $59' 8.3''$: the Moon, therefore, departs Eastward from the Sun $12^{\circ} 11' 27''$ every 24 hours. On the 8th day, or about a week after conjunction, it will be 90° from the Sun. This phase is at the *maximum elongation East*, or *Eastern quadrature* (E. \square), and is popularly known as the “First quarter” (D). The Moon, previously a crescent, is then halved¹, with its illuminated limb turned towards the Sun. Proceeding onwards, it becomes gibbous, and about 14 days from conjunction attains an angular distance of 180° from the Sun. It is then in *opposition* to the Sun (P), and the Moon is said to be “Full” (\circ). At the end of another period of 7 days, or 21 from conjunction, the Moon, after becoming gibbous, is again halved; but it is the opposite limb which is now illuminated. This phase is at the *maximum elongation West*, or *Western quadrature* (W. \square), and is popularly known as the “Last quarter” (C). Finally, after another 7 days, the Moon again comes into conjunction.

The length of the Synodical Revolution of the Moon, or Lunar Month, is $29^{\text{d}} 12^{\text{h}} 44^{\text{m}} 2.873^{\text{s}}$.

(6) In nearly every Almanac there is a column assigned to the “Moon’s age.” This is simply the interval in days and parts of a day which has elapsed since the Moon’s last conjunction

¹ *Dichotomised* is the technical term.

with the Sun. Thus, on Wednesday, January 1, 1890, we find that at noon the Moon's age was $10^{\circ}0^d$: this means that 10°0 days had elapsed since the last previous conjunction on Dec. 22, 1889. An examination of the dates of several successive New Moons will show that the lengths of different lunations differ considerably, owing to the varying velocity of the Moon's orbital motion: this is due to numerous and complicated physical causes, which cannot be conveniently examined here. In associating any lunation with any particular month, it may be well to mention that the Moon does not take its name from the month in which it passes the principal part of its time, but from the one in which the lunation terminates. Thus, in the year 1875, the "September Moon" is that which commenced on August 30, and terminated on September 29. All writers on chronology agree in this arrangement, which is sometimes attended with rather absurd consequences. There were, in fact, in 1875, two "August Moons;" the whole of the first, however, with the exception of 13^h , belonging to the month of July. Since the month of February in a common year only contains 28 days, and a lunar month always exceeds 29 days, it will sometimes happen that there will be no "February Moon" at all.

It is not necessary to advert to the civil portion of the Calendar further than to mention that Quarter-days, Law and University Term-days, and anniversaries of important by-gone events, &c., all find a place in every well-edited Almanac.

The Ecclesiastical Calendar has for its object the arrangement of the different Sundays and festivals of the Church. Some religious festivals—such as the Feast of St. Andrew, the Nativity of our LORD, the Annunciation of the Blessed Virgin, &c.—are observed on the same day of the month every year; others, such as Easter, return on different days in different years, whence they are termed *Moveable Festivals*. Easter is the most important of all, for upon this depend nearly all the rest.

The Jewish Feast of the Passover was observed in accordance with the following commands:—"In the 1st month, on the 14th day of the month at even, ye shall eat unleavened bread, until

the 21st day of the month at even." (*Exodus*, xii. 18.) Again:—"In the 14th day of the 1st month at even, is the LORD'S Passover." (*Leviticus*, xxiii. 5.) And since our SAVIOUR was crucified at the time of the Jewish Passover, our festival of Easter has ever been a moveable one. The word 'Easter' is probably of Saxon origin, for the ancient Saxons sacrificed in the month of April to a goddess whom they called Eoster (in Greek *Astarte*, and in Hebrew *Ashtaroth*¹), whose name was given to the month in question. It has been suggested that the word *East* in Saxon refers to "rising," and that the point of the compass now known by that name derived it from the rising of the Sun, and the festival from the rising of our SAVIOUR. Another derivation is the Saxon *yst*, a storm, on account of the tempestuous weather which frequently prevails at this season of the year. That the observance of Easter as a Christian institution is as ancient as the times of the Apostles there can be no doubt; but in the 2nd century a controversy arose as to the exact time at which it ought to be celebrated. The Eastern Church elected to keep it on the 14th day of the 1st Jewish month; and the Western on the night which preceded the anniversary of our SAVIOUR'S Resurrection. The objection to the former plan was, that the festival was commonly held on some other day than the 1st day of the week, which was undoubtedly the proper one. The disputing Churches each had their own way until 325 A.D., when the Council of Nicæa took up the matter, and eventually it came to be recognised that Easter was to be kept on the Sunday which falls next after the first Full Moon following the 21st of March, the vernal equinox. If a Full Moon fall on the 21st of March, then the next Full Moon is the Paschal Moon; and if the Paschal Moon fall on a Sunday, then the next Sunday is Easter Day.

By common consent, it is not the apparent or real Sun and Moon which is employed in finding Easter, but the mean or fictitious sun and moon of astronomers. We must, therefore,

¹ Vide Milton, *Paradise Lost*, bk. i. l. 438, where it is referred to as a Phœnician deity. That the name of the Saxon

Goddess quoted above is in any way connected with *Astarte* seems now mere fancy.

not be surprised at finding sometimes the Easter of any year not agreeing with the above definition. Such was the case in 1845 and in 1818, when violent controversies took place about it. Suppose, for instance, that the real opposition of the Sun and Moon took place at 11^h 59^m P.M., March 21, and the mean opposition 2^m afterwards. It is clear that, counting by the real bodies, the Full Moon in question would not be the Paschal Moon, while that of the mean bodies would be so^m. However, the following rules will determine the Easter Day of chronologists for any year of the Christian era, and this is all that is necessaryⁿ:—

- I. Add 1 to the given year.
 - II. Take the quotient of the given year, divided by 4, neglecting the remainder.
 - III. Take 16 from the centurial figure of the given year if it can be done.
 - IV. Take the remainder of III, divided by 4, neglecting the remainder.
 - V. From the sum of I, II, and IV, subtract III.
 - VI. Find the remainder of V, divided by 7.
 - VII. Subtract VI from 7: this is the number of the DOMINICAL LETTER.
- | | | | | | | |
|---|---|---|---|---|---|---|
| A | B | C | D | E | F | G |
| 1 | 2 | 3 | 4 | 5 | 6 | 7 |
- VIII. Divide I by 19: the remainder (or 19 if there is no remainder) is the GOLDEN NUMBER.
 - IX. From the centurial figures of the year subtract 17, divide by 25, and keep the quotient.
 - X. Subtract IX and 15 from the centurial figures, divide by 3, and keep the quotient.
 - XI. To VIII add 10 times the next less number, divide by 30, and keep the remainder.
 - XII. To XI add X and IV, and take away III, throwing out the thirties, if any. If this gives 24, change it into 25. If 25, change it into 26, whenever the Golden Number exceeds 11. If 0, change it into 30. Thus we get the EPOCH.

When the epoch is 23 or less.

- XIII. Subtract XII from 45.
- XIV. Subtract the Epoch from 27, divide by 7, and keep the remainder.

When the Epoch is greater than 23.

- XIII. Subtract XII from 75.
- XIV. Subtract the Epoch from 57, divide by 7, and keep the remainder.

^m The investigation of this question is too long and complicated to interest the general reader. Those who wish for it will find it in a valuable memoir, by Prof.

De Morgan, in the *Companion to the Almanac* for 1845, p. 1.

ⁿ Gauss's method is a very good one.

- XV. To XIII add VII (and 7 besides, if XIV be greater than VII) and subtract XIV, the result is the day of March, or, if more than 31, subtract 31, and the result is the day of April on which Easter day falls.

The following exemplifies the above rule:—

To find when Easter falls in 1880.

- I. $1880 + 1 = 1881.$
 II. $\frac{1880}{4} = 470 : 0 \text{ rem.}$
 III. $18 - 16 = 2.$
 IV. $\frac{2}{4} = 0 : 2 \text{ rem.}$
 V. $1881 + 470 + 0 - 2 = 2349.$
 VI. $\frac{2349}{7} = 335 : 4 \text{ rem.}$
 VII. $7 - 4 = 3 : \text{whence C is the DOMINICAL LETTER.}$
 VIII. $\frac{1881}{19} = 99 : 0 \text{ rem. } \therefore 19 \text{ is the GOLDEN NUMBER.}$
 IX. $\frac{18 - 17}{25} = 0 : 1 \text{ rem.}$
 X. $\frac{18 - (0 + 15)}{3} = 1.$
 XI. $\frac{19 + 180}{30} = 6 : 19 \text{ rem.}$
 XII. $19 + 1 + 0 - 2 = 18 : \text{which is the EPACT.}$
 XIII. $45 - 18 = 27.$
 XIV. $\frac{27 - 18}{7} = 1 : 2 \text{ rem.}$
 XV. $27 + 3 - 2 = 28 ; \text{so March 28 is Easter day.}$

Gauss's method is as follows:—

- I. Divide the given year by 19, 7, and 4 : call the several remainders a, b, c
 II. Divide $19a + 23$ by 30 : call the remainder d .
 III. Divide $4b + 2c + 6d + 4$ by 7 : call the remainder e .

Then—

If $d + e$ is less than 9, Easter will fall on the $(22 + d + e)$ day of March.

If $d + e > 9$, Easter is the $(d + e - 9)$ day of April.

Easter Day being known, any of the other days depending on it can readily be found.

Septuagesima Sunday is 9 weeks

Sexagesima Sunday is 8 weeks

Shrove or Quinquagesima Sunday is 7 weeks

Shrove Tuesday and *Ash Wednesday* follow *Quinquagesima Sunday*

Quadragesima Sunday is 6 weeks

Palm Sunday is 1 week

Good Friday is 2 days

Low Sunday is 1 week

Rogation Sunday is 5 weeks

Ascension Day, or *Holy Thursday*, follows *Rogation Sunday*

Whitsun-Day is 7 weeks

Trinity Sunday is 8 weeks

} Before Easter.

} After Easter.

On the subject of the calculation of Easter, and indeed of the Calendar generally, see the works named in the note °.

° *English Cycl.*, various articles; *Book of Almanacs*; *Companion to the Lord Grimthorpe's Astronomy without Almanac*, 1845; *Rees's Cycl.*; J. J. Bond's *Perpetual Calendar*.
Mathematics, chap. iii; De Morgan's

CHAPTER IV.

CYCLES.

The Dominical or Sunday Letter.—Method of finding it.—Its use.—The Lunar or Metonic Cycle.—The Golden Number.—The Epact.—The Solar Cycle.—The Indiction.—The Dionysian period.—The Julian Period.—De Cheseaux's investigation of the Cycles mentioned in the Book of Daniel.

THE *Dominical Letter*, called also the *Sunday Letter*, is an expedient by means of which we can readily find out the day of the week on which any day of the year falls, if we know the day of the week on which New Year's Day falls. To the first 7 days of January are affixed the first 7 letters of the alphabet—A, B, C, D, E, F, G; and of these, that which denotes Sunday is the *Dominical Letter*. Thus, if Sunday is New Year's Day, then A is the *Dominical Letter*; if Monday, that letter is G; and so on. If there were 364 days, or 52 weeks, exactly in the year, then the *Dominical Letter* would always be the same; but as the year contains about $365\frac{1}{4}$ days, or $1\frac{1}{4}$ more than 364, this excess has to be taken into account every year, and the $\frac{1}{4}$ makes a day in every 4 years; so that the *Dominical Letter* falls backward *one* letter every common year, and *two* letters every *Bissextile* or *Leap year*. Knowing the *Dominical Letter*, we can ascertain all the *Sundays*, or all the *Mondays*, &c., in the year. The reason why *Leap years* have 2 letters may be thus explained:—Take, for example, the year 1880. The year begins on a *Thursday*, so that D is the *Sunday Letter*; but the *intercalary day*, *February 29*, throws back the 1st of *March* a day later than it would otherwise have been, and therefore the

Sunday Letter for the following 10 months is thrown back 1—that is to say, to C; so that the Dominical Letters for 1880 are D and C. The following examples, worked according to the 1st part of the rule already given to find Easter, illustrate the practical use of a knowledge of the Dominical Letter:—

1. What day of the week is June 4, 4779?

I. $4779 + 1 = 4780.$

II. $\frac{4779}{4} = 1194 : 3 \text{ rem.}$

III. $47 - 16 = 31.$

IV. $\frac{31}{4} = 7 : 3 \text{ rem.}$

V. $4780 + 1194 + 7 - 31 = 5950.$

VI. $\frac{5950}{7} = 850 : 0 \text{ rem.}$

VII. $7 - 0 = 7. \therefore G \text{ is the Dom. Letter.}$

Now June 3 has G affixed to it, and is Sunday; whence June 4, 4779, will fall on Monday.

2. What is the 1st Sunday in June, 1880?

I. $1880 + 1 = 1881.$

II. $\frac{1880}{4} = 470 : 0 \text{ rem.}$

III. $18 - 16 = 2.$

IV. $\frac{2}{4} = 0 ; 2 \text{ rem.}$

V. $1881 + 470 + 0 - 2 = 2349.$

VI. $\frac{2349}{7} = 335 : 4 \text{ rem.}$

VII. $7 - 4 = 3. \therefore C \text{ is the Dom. Letter.}$

Now June 6 has C affixed to it, so that day is the 1st Sunday in June in 1880.

Since the Solar year consists of $365^d 5^h 48^m 48^s$, therefore 19 Solar years will consist of about—

$$6939^d 14^h 27^m 12^s ;$$

and since the mean duration of a Lunar month is $29^d 12^h 44^m 3^s$, therefore 235 mean Lunar months will consist of about—

$$6939^d 16^h 31^m 45^s.$$

Thus we see that 19 Solar years fall short of 235 Lunar months by only $2^h 4^m 33^s$; if, therefore, any given length of time be

resolved into periods of 19 years each, the same phases of the Moon which are presented in any year of one cycle will be reproduced in the corresponding year of the following cycle, but $2^h 4^m 33^s$ later. If we reckoned time by Solar years, and if the length of each lunation were always $29^d 12^h 44^m 3^s$, the days of the Moon's changes in any one cycle being known, the days of the Moon's changes in every succeeding and every preceding cycle could be easily ascertained. But since the Solar year of $365^d 5^h 48^m 48^s$ is not employed, and the duration of different lunations varies, the reproduction of Lunar phases on corresponding days does not take place.

“Unlike the Astronomical year [Solar], the Civil year is not constantly of the same length. It consists, as has been already explained, sometimes of 365 and sometimes of 366 days. Neither is a cycle of 19 successive Civil years always of the same length. Such a cycle contains sometimes only 5 and sometimes 4 Leap years, and consists, therefore, sometimes of 6940 and sometimes of 6939 days. It, therefore, sometimes exceeds a cycle of 19 Astronomical years by nearly $\frac{1}{4}$ day, and sometimes falls short of such a cycle by more than three-quarters of a day. If 4 successive cycles of 19 Civil years be taken, 3 of them will exceed 1 Astronomical year by something less than $\frac{1}{4}$ day, and the 4th will fall short of an Astronomical year by something more than $\frac{3}{4}$ day. The total length of the 4 successive cycles of 19 Civil years will be as nearly as possible equal to 4 cycles of 19 Astronomical years^a.

“Thus it is evident that the Civil year, though variable in length, oscillates alternately on one side and the other of the Astronomical year; and, in like manner, the cycle of 19 Civil years, which is also variable by 1 day, oscillates at each side of the cycle of 19 Astronomical years. The Civil year and the Civil cycle are alternately overtaking and overtaken by the Astronomical year and cycle, and their average lengths are

^a This cycle of 76 years (19×4) is known as the *Calippic period*, from Calippus who first drew attention to it.

The paragraph in the text and the two following ones are from the *Museum of Science and Art*, vol. vii. p. 13.

respectively equal in the long run to the average length of the latter. In like manner the Lunar month is subject to a certain limited variation; so that the phases of the real Moon are alternately overtaking and overtaken by those of the average moon.

“Now, let us imagine a fictitious moon to move round the heavens in the path of the real Moon, but with such a motion that its periodical phases shall take place in exact accordance with the Civil years, and with the cycles of 19 Civil years, in the same manner as the phases of the real Moon recur in the succession of Astronomical years, and in the cycles of 19 Astronomical years. Such a fictitious moon is then the Ecclesiastical Moon, and is the Moon whose phases are predicted in the Calendar. It will be evident from all that has been explained that this Ecclesiastical Moon will alternately pursue, overtake, and outstrip the real Moon, and be pursued, overtaken, and outstripped by it; that they will thus make together their successive revolutions of the heavens, and that they will never part company, nor either outstrip or fall behind the other beyond a certain distance, which is limited by the extent of the departure of the Civil from the Astronomical year, and by that of the real from the average Lunar month.”

The course of time is now considered to be made up of so many cycles each of 19 Civil years; and it has been agreed that each cycle shall commence with a year, the 1st day of which shall be the last of the preceding lunation, or the day on which the age of the following Moon is 0. The current cycle commenced in 1881, and therefore will not have run its course until 1899. The number which marks the place of any given year in the cycle is termed the *Golden Number*, and the period the *Lunar* or *Metonic Cycle*, from its discoverer, Meton^b. When the discovery of this cycle was first published, so great was the popular favour which was bestowed upon it, that it was ordered to be recorded on public monuments in letters of

^b Some further useful information on the Metonic Cycle and the Golden Number will be found in Newcomb's *Astronomy*, p. 48. Eng. Ed.

gold^c. The age of the Ecclesiastical Moon on the 1st day of the 1st year of the cycle being known, its age upon the 1st day of any succeeding year of the cycle may be determined. The number which expresses the age of the Moon upon the 1st day of any year of the cycle is called the *Epact*. The series of Epacts corresponding to the years of a Lunar cycle are given in the following table:—

Year of Cycle	1	2	3	4	5	6	7	8	9	10	11	12	13	14	15	16	17	18	19
Epact	0	11	22	3	14	25	6	17	28	9	20	1	12	23	4	15	26	7	18

The method of finding the Golden Number and Epact for any given year has already been shown in the rule for finding Easter.

The *Solar Cycle* is the period of years that elapses before the days of the week correspond to the same days of the month. If there were 364 days in the year, this would happen every year; if 365, it would happen every 7th year; but because the $\frac{1}{4}$ of a day makes an alteration of a whole day in 4 years, the cycle must extend to 7×4 , or 28 years. Nine years of this cycle had elapsed at the birth of Christ. Therefore, *to find the cycle of the Sun, add 9 to the given year, and divide by 28, and the quotient will be the number of cycles since the commencement of the Christian Era, and the remainder is the cycle of the Sun.*

Example. To find the Cycle of the Sun for 1880:—

$$\text{I. } 1880 + 9 = 1889.$$

$$\text{II. } \frac{1889}{28} = 67 : 13 \text{ rem. ;}$$

whence 13 is the number in the Solar Cycle for the given year.

The cycle of the *Indiction* has no immediate connexion with the motions of the Sun and Moon, but it may, however, as well be referred to here. It is a period of 15 years, which first came into use as a conventional division of time in the Roman empire about the reign of the Emperor Constantine in connection with the payment of a tribute called for by edicts issued at intervals of 15 years. The origin of this period as a time-period is involved

^c The Metonic Cycle was adopted on July 16, 432 B.C., and the New Moon, which happened at 7^h 43^m P.M., was the actual commencement of it.

in much obscurity. It has been conjectured, though Arago considers the notion baseless, that it was designed to supersede the Pagan method of reckoning time by Olympiads—periods of 4 years, familiar to every classical reader. Unlike the Golden Number and the Epact, the Indiction was purely a Civil period. Gregory VII. finally fixed upon the 1st day of the year 313 A.D. as the commencement of the Indiction, whence it follows that the 1st year of the Christian era was the 4th of the current Indiction. *To find the Indiction, add 3 to the given year, and divide by 15, and the remainder will be the Indiction.*

Example. To find the Indiction for 1880:—

$$\text{I. } 1880 + 3 = 1883.$$

$$\text{II. } \frac{1883}{15} = 125 : 8 \text{ rem. ;}$$

whence 8 is the Indiction of the given year.

The *Dionysian Period* is obtained by a combination of the Lunar and Solar cycles, forming a period of 532 years ($19 \times 28 = 532$); at the end of which time the changes of the Moon take place on the same days of the week and month as before. This period is said to be valuable for testing the accuracy of chronological statements.

The *Julian Period*, a period useful in chronology, is obtained by multiplying together the Lunar cycle, the Solar cycle, and the Indiction, forming a period of 7980 years—

$$(19 \times 28 \times 15 = 7980.)$$

“The number 7980 is formed by the continual multiplication of the 3 numbers 28, 19, and 15: that is of the cycle of the Sun, the cycle of the Moon, and the cycle of Indiction. The 1st year of the Christian Era had 10 for its number in the cycle of the Sun, 2 in the cycle of the Moon, and 4 in the Indiction. Now the only number less than 7980 which on being divided successively by 28, 19, and 15, leaves the respective remainders 10, 2, and 4, is 4714. Hence the 1st year of the Christian Era corresponded with 4714 of the Julian period^d.” The 1st year of the Julian period was therefore 4713 B.C. It was Scaliger who

^d Brande's *Dictionary*, art. “Julian Period.”

propounded this period. Its practical value consists in the fact that by the use of it astronomers and chronologists can ascertain readily and accurately the interval of time in days or years between any two given events, such as the perihelion passages of a periodical comet or the maxima or minima of a variable star^e.

This will be a convenient place to mention that for dates before the Christian Era astronomers adopt a method of reckoning differing from that used by chronologists. Thus 584 B.C. astronomical reckoning, corresponds to 585 B.C. chronological reckoning^f. Sometimes astronomical dates of events happening before the birth of our SAVIOUR are given in this form: (-584), as being, in some sense, negative quantities. In comparing, or, generally, in dealing with, dates antecedent to the Christian Era, due attention to these distinctions is of prime importance.

In preceding paragraphs we have considered the more familiar combinations of periods known to and used by chronologers and astronomers, but others exist of which some deserve brief notice here^g.

About the middle of the 18th century the Swiss astronomer De Cheseaux—he who observed the 6-tailed comet of 1744—was led to inquire whether any special significance in a scientific or

^e Full particulars as to the use of the Julian Period will be found in Sir J. Herschel's *Outlines of Astronomy*, 7th ed., p. 678, and a Working Table of the Period in days is given in the *Nautical*

Almanac every year, with an explanation on a later page of its use.

^f The cause of this will be seen from the following table of the respective methods of progression:—

<i>Astronomical.</i>		<i>Chronological.</i>
- 3	=	4 B.C.
- 2	=	3 B.C.
- 1	=	2 B.C.
0	=	1 B.C.
1 A.D.	=	1 A.D.
2 A.D.	=	2 A.D.
3 A.D.	=	3 A.D.

^g The standard work on chronology is Ideler's *Handbuch der mathematischen und technischen Chronologie*. Eras and

epochs are treated of at length by De Morgan in the *Companion to the Almanac*, 1850, p. 5.

chronological sense attached to the periods of 1260 and 2300 years assigned in the Books of Daniel and Revelation as the duration of the Gentile Empires whose course the writers of those books foretold. De Cheseaux was not long in ascertaining that these periods are soli-lunar cycles, whilst the difference between them—1040 years—is the largest accurate soli-lunar cycle known. The data by means of which De Cheseaux arrived at this discovery will be found in a book which he published^h. It is now exceedingly scarce, but a copy exists in the British Museum. The data in question were submitted to and examined by Mairan and Cassini, and by them pronounced sound. Mairan said, "It was impossible to doubt the facts and discoveries the book contained, but that he could not conceive *how* or *why* they had come to be embodied so distinctly in the Holy Scriptures." Cassini pronounced the conclusions perfectly consistent with the most exact astronomy.

De Cheseaux's results are sufficiently interesting to deserve some extended notice, and as far as the exigencies of space permit they shall be given as nearly as possible in his own words. He beginsⁱ by explaining a cycle to be "a period which brings into harmony different celestial revolutions, containing a certain definite number of each, without remainder or fraction," and then he goes on to point out that the Sun, Earth and Moon may be presumed to present cycles of the 4 following kinds:—

1. Those harmonising the *solar day* and *solar year*.
2. Those harmonising the *solar year* and *lunar month*.
3. Those harmonising the *solar day* and *lunar month*.
4. Those harmonising all three—*solar day*, *lunar month*, and *solar year*.

Such cycles have an important chronological or calendar value. Day, month and year are fundamental but *incommensurate* measures of time. In any calendar like the Jewish, closely adjusted throughout to the triple order of natural times, cycles which

^h *Mémoires posthumes de M. De Cheseaux : Remarques historiques, chronologiques, et astronomiques, sur quelques*

endroits du livre de Daniel. Lausanne, 1754.

ⁱ *Op. cit.*, p. 20.

harmonise these are of primary importance. The use of the 19-year Metonic cycle in Grecian, Jewish and Christian calendars, and of the 28-year solar cycle, and 532-year cycle of Easter in the last-named, illustrate their practical value.

The error of the Metonic cycle ($2^h 4^m 4^s$) amounts to 33 hours in 16 cycles, or 304 years, while the error of the 315-year cycle (to be presently referred to) is but 3 hours. In 66 Metonic cycles, or 1254 years, the error of that cycle amounts to $5^d 16^h$, while in the 1260 years the error of the 315-year cycle is about half a day. (The error in 315 years being $3^h 24^m$, the error in 1260 years will be $3^h 24^m \times 4 = 13^h 36^m$.)

De Cheseaux adds, that astronomers and chronologists have considered the discovery of cycles "so difficult a matter that they have almost laid it down as a principle that it is impossible, at any rate as regards those of the 4th class. . . . Anxious to settle whether the thing were really impossible, I began some time ago to try for a cycle of the 2nd kind." De Cheseaux then describes how he was led to the discovery of the fact that the period of 315 years constitutes a cycle ten times more exact than the celebrated Metonic Cycle of the Ancients, the Sun and Moon coming after the lapse of that period to within $3^h 24^m$ of absolute agreement. He next proceeds:—

"I had no sooner discovered this cycle than I observed that it was $\frac{1}{4}$ th of the 1260 years of Daniel and the Apocalypse, and that consequently this period is itself a soli-lunar cycle," after which the Sun and Moon return, "within less than $\frac{1}{2}^\circ$, to the same point of the ecliptic precisely," and that within an hour of each other."

Some further remarks by De Cheseaux in this connection will be read with interest:—

"As I said before, a cycle of this kind had long been sought in vain: no astronomer or chronologist had been able to light upon one for 19 centuries; and yet for 2300 years, there it has been, written in characters legible enough, in the Book of Daniel: legible, that is, to him who was willing to take the trouble of comparing the great prophetic periods of 1260 years and 2300 years with the movements of the heavenly bodies; in other words, to him, who compared the Book of Nature with the book of Revelation. . . .

"The slightest error in the determination of the length of the solar year or of the lunar month would lead astray computers seeking a real cycle much more than one might expect: only the perfection of modern astronomical instruments, in fact,

can demonstrate it at all. So that we have the problem, How did Daniel, whoever he was (if, as some assert, the prophecy is of a later date than Daniel), light upon these undiscoverable and undiscovered, yet excessively accurate celestial cycles, at a time when there were no instruments in existence capable of measuring solar revolutions with sufficient accuracy to reveal the cyclical character of the periods? . . .

“ I close with 2 or 3 observations. For many ages the Book of Daniel, and especially those passages of it which I have dealt upon, have been quoted and commented on by a great number of different authors, so that it is impossible to call in question their antiquity. Who can have taught their author the marvellous relation between the Periods he employed and the movements of the heavenly bodies? . . . Is it possible, considering all these points, to fail to recognise in the author of these ancient Books, the Creator of the heavens, of the earth and of the sea, and of the things which to them belong^k ? ”

The cyclical character of 1260 years suggested to De Cheseaux the thought that the 2300 years of Daniel might be also a cycle. On investigating the matter he found that at the end of 2300 Gregorian years, minus 6^h 14^s, the Sun and Moon returned to within half a degree of the place from which they started, and that an hour later the Sun reaches its exact starting-point on the ecliptic; whence it follows that the prophetic period of 2300 years is a cycle so perfect, that though it is thirty times longer than the celebrated cycle of Calippus (invented to correct the Metonic cycle), it has an error of only 13^h, $\frac{1}{17}$ th of the error of that ancient cycle (8^d 12^h). Modern Tables indicate the error to be still less.

The similarity of the errors of the 1260-year and 2300-year cycles led De Cheseaux to conclude that the difference between these periods, or 1040 years, ought to be a very perfect cycle of the fourth kind, harmonising day, month, and year. On examining it by the best Tables then in existence he found it to be so; a cycle at once solar, lunar and diurnal, of perfect accuracy. In calculating the measures of these cycles De Cheseaux adopted

^k The first to call attention in England to De Cheseaux's conclusions seems to have been Mr. W. Cuninghame in an article in the *Christian Observer* for 1811, p. 404. This he followed up by a pamphlet *On the Jubilean Chronology of the Seventh Trumpet of the Apocalypse* (Glasgow, 1834), but the matter did not come under general notice till after the further

investigations of H. G. Guinness had been made public in his *Approaching End of the Age*, 8vo. London, 1878. Guinness fortified himself with the opinion of Professor J. C. Adams of Cambridge, and there is evidently no question as to the astronomical accuracy of De Cheseaux's views.

for the standard of the solar year a mean between the values assigned by Cassini, Flamsteed, De La Hire, Bouillaud and Tycho Brahe.

The mean between the values of Tycho Brahe and Flamsteed, which is almost exactly the $365^{\text{d}} 5^{\text{h}} 48^{\text{m}} 51.61^{\text{s}}$ of Delambre's Tables, has been reduced in Hansen's Tables and Leverrier's Tables by 5 seconds. The standard of the synodic month has also been reduced by the fraction of a second. The effect of this double correction is *to exhibit more clearly the accuracy of the 1260 and 2300 years cycles*, for in each of these the solar years are slightly in excess of complete lunations, and the correction diminishes the amount of that excess.

By the *Nautical Almanac* standard of the solar year (365.242216^{d}) the 1040-year cycle has an error of only $1\frac{1}{2}^{\text{h}}$, as a cycle of the month and year. Thus:—

$$\begin{aligned} 1040 \text{ tropical years} &= 379851^{\text{d}} 21\frac{1}{2}^{\text{h}}, \\ 12863 \text{ lunations} &= 379851^{\text{d}} 23^{\text{h}}. \end{aligned}$$

The standard measure of the lunar month (or the Moon's synodical revolution) can be correctly obtained from this cycle, to 5 places of decimals.

While the use of the best modern Tables only increases the accuracy of the 1260-year and 2300-year cycles, and leaves the 1040 years cycle in close accord, as cycles harmonising the lunar month with the solar year, it impairs the value of the latter as a cycle of the fourth class, harmonising the year and month with the solar day.

Such briefly were De Cheseaux's discoveries. To these will now be added some of Mr. Grattan Guinness's with reference to these cycles made while studying the connection of natural and revealed chronology. Guinness observed—

1. *That the 2300-year cycle is the primary natural cycle for the correction of the Metonic cycle, and that it may be considered as simply an expanded Metonic cycle.* Before Meton earned Athenian honours by discovering the celebrated 19-year cycle which bears his name, the prophet Daniel had embodied in his revealed chronology the grand cycle naturally adapted to correct the error of the

Metonic cycle. The use of the 19-year cycle or "golden number" is indispensable in a calendar adjusted to the months and years of nature. The slight error of that cycle ($2^h 4^m 4^s$) accumulates to nearly an entire day ($22^h 44^m$) in 11 cycles, or 209 years, and to nearly 11 days ($10^d 10^h$) in 11×11 cycles, or 2299 years, which error *is balanced by the 11 days epact* in the 2300th year. The epact of any single year is 11 days, and the 11 days *excess* of the lunar months above 2299 solar years, in 121 Metonic cycles, *becomes the epact of the 2300th year*. The 2300-year cycle, which is 33 times more exact than the Metonic, and is the primary cycle adapted to its correction, is thus *the natural secular basis* for a calendar correctly adjusted to solar and lunar revolutions.

2. That the accumulated epacts of 2300 years, or the difference between 2300 lunar years and the same number of solar, make up exactly 70 lunar years and 7 months, a measure harmonious with the 7 months epact in the Metonic cycle, and with the prevailing septiform character of the prophetic times. The rate of epact is remarkable as being 1 month in 1000 days (992^d); 12 months, or a lunar year, in 12000 days (the 33 years Messianic cycle); and 70 times this in 2300 years.

3. That 2300 years is not only a cycle of the solar year and synodical month, as De Cheseaux discovered, but is also a cycle of the anomalistic lunar month. The anomalistic month is 27.5546 days, and:—

$$\begin{aligned} 30487 \text{ anomalistic months} &= 840057.09^d, \\ 28447 \text{ synodical months} &= 840056.67^d, \\ 2300 \text{ solar years} &= 840057.09^d. \end{aligned}$$

Lunar cycles are contracted or enlarged in their various returns according to the Moon's anomaly. The maximum difference is $9^h 47^m$, acceleration or retardation of new Moon from this cause; together $19\frac{1}{2}$ hours. The 2300 years, being a cycle of the anomalistic month, is free from this important error. The addition of this element to the other cyclical features in 2300 years makes it an unrivalled lunar cycle.

4. That the number 2520, of which 1260 is an evident fraction, is

the least common multiple of the first ten numbers. Twelve hundred and sixty years are $3\frac{1}{2}$ "times" (each "time" being a period of 360 years) and are simply half the week of "times" or 2520 years. The arithmetical property of 2520 just mentioned gives rise to a large number of divisors, and adapts it to the position which it holds as the measure of the many-jointed vertebral column (so to speak) of the prophetic times.

5. That the addition of 75 years to 1260 years, and thus to the whole "seven times" or 2520 years, which is made in the prophecies of Daniel, is also made by natural solar and lunar revolutions. If any 2520 lunar years and 2520 solar years are taken as commencing at the same point, the former will terminate 75 solar years before the latter.

6. That the error of the 30-year cycle (the "month" of the prophetic times) is self-corrected in the "42 months" of prophecy, or 1260 years. ($30 \times 42 = 1260$.) Thirty years is a cycle both in its lunar and solar forms, adapting the prophetic times to both reckonings. 2520 lunar years are a chain of 84 cycles of the former kind, while 2520 solar years are a chain of 84 cycles of the latter; the one chain being 75 years longer than the other. Thirty lunar years constitute a very exact cycle of the month and day, and indeed form the basis of the Mahomedan calendar. If the lunar month be reckoned as $29^d 12^h 44^m$ (which is simply to omit three seconds) the cycle is absolutely exact. Thirty solar years, on the other hand, form a cycle of the solar year and lunar month, with an error of $1^d 10^h 2^m$; this error accumulates to a month in 630 years, and therefore to 2 months in 1260 years, which latter is a cycle of the month and year a hundred times more accurate than the 30-year cycle whose error it corrects.

7. That 2300 years is exactly 40 days of the "annus magnus" of the revolution of the solar Perigee with referencè to the Equinoxes. The stellar direction of the Earth's elliptic orbit has a slow forward revolution completed in 109800 years; while the Equinoxes sweep back in a contrary direction, accomplishing their revolution in 25870 years. The compound result is an

advance of the solar Perigee with reference to the Equinoxes of one day in $57\frac{1}{2}$ years, or 40 days in 2300 years, and 365 days, or a complete revolution, in nearly 21000 years.

The annual difference between the anomalistic and tropical years is as follows :—

$$\begin{array}{r}
 \text{Anomalistic year} = 365^{\text{d}} 6^{\text{h}} 13^{\text{m}} 49^{\text{s}} \\
 \text{Tropical year} \quad = 365^{\text{d}} 5^{\text{h}} 48^{\text{m}} 46^{\text{s}} \\
 \hline
 \text{difference} \qquad \qquad \qquad 25^{\text{m}} 3^{\text{s}} \\
 \text{But } \frac{1}{2300} \text{ of 40 days} = \qquad \qquad 25^{\text{m}} 2.6^{\text{s}}
 \end{array}$$

At the present time the solar Perigee, or nearest approach of the Sun to the Earth, coincides with the 1st of January. During the last 2300 years the Perigee has swept forward the 40 days extending from November 22 to January 1.

Such are some of the adjustments which astronomy discloses between the prophetic times and the periods which affect the material universe. They are adjustments of such a character as only modern science with its instruments of exact precision could discover, and were of necessity unknown to the prophets of bygone ages. The periods which the prophets foretold as destined to measure cycles of moral harmonisation are themselves cycles of material harmonisation. There is a mutual adjustment between the material and moral worlds. The course of revealed redemption chronology, Levitical and prophetic, is in profound and exact agreement in all its details and all its extent with the Time Order of the Universe—facts which might suggest many interesting reflections did space permit.

BOOK XI.

A SKETCH OF THE HISTORY OF ASTRONOMY^a.

IT is not intended here to enter into a regular history of Astronomy, for that would occupy more space than could be afforded for the purpose; what follows is simply a chronological summary of the rise and progress of the science from the earliest period^b.

It is difficult to assign any exact date for the origin of Astronomy, so ancient and so lost in obscurity is it: I begin therefore with—

B.C.

720. Occurrence of an eclipse of the Moon, observed at Babylon, and recorded by *Ptolemy*.

719. Occurrence of 2 eclipses of the Moon, also observed at Babylon, and also recorded by Ptolemy.

639—546. *Thales*, of Miletus, founder of the Ionian School, and of Astronomy and Geometry in Greece.

610—547. *Anaximander*, of Miletus, an astronomical speculator.

600 ±. Mimnermus records the “myth” that the Sun after setting is carried round the Earth in a golden bowl until it is brought into view again in the East.

594. *Solon* “reforms” the Calendar, making it *less* accurate than it was before^c.

585. Occurrence of a solar eclipse, said to have been predicted by *Thales*.

569—470. *Pythagoras*, founder of the School of Croton. He leaves no writings.

545. *Anaximander* erects the first Sun-dial at Sparta.

^a A very interesting Calendar of Astronomical Events, arranged under the various months of the year, from the pen of G. J. Walker, was published as a supplement to the *Ast. Reg.* vol. vii. (1869).

^b The first time an astronomer's name

occurs it is printed in Italics. Star Catalogues are not as a rule noticed here, they having been dealt with more fully in Book XII.

^c How much like many modern reforms

- 540—500. *Xenophanes*, of Colophon, founder of the Eleatic School. He thinks that the heavenly bodies are luminous clouds.
525. *Anaximenes*, who considers that the Sun is *flat* like a leaf.
- 520—460. *Parmenides*, of Elea, who is said to have taught the sphericity of the Earth, and the identity of the morning and evening stars.
504. *Heraclitus*, of Ephesus, an astronomical speculator.
- 499—430. *Anaxagoras*, of Clazomenæ, geometer and active observer. Correctly explains eclipses, and is prosecuted for impiety.
- 490 ±. *Alemæon*, of Croton, who states that the planets move from W. to E., or contrary to the apparent diurnal motion of the stars.
- 469—399. *Socrates*, who discourages the study of astronomy, except so far as is necessary for the measurement of time and land.
- 459—360. *Democritus*, of Abdera, who writes on astronomical and mathematical subjects.
455. *Empedocles*, of Agrigentum, who writes on the constitution of the universe.
450. *Diogenes*, of Apollonia, who states that the inclination of the Earth's axis is intended to cause the seasons.
433. *Meton* erects the first Sun-dial at Athens.
432. *Meton* introduces the luni-solar period of 19 years.
424. *Meton* and *Euctemon* observe a solstice at Athens.
406. *Eudoxus*, of Cnidus, geometer and mathematician.
400. *Philolaus*, a distinguished disciple of Pythagoras, the first to commit to writing his master's opinions. Perhaps even he may be credited with the first enunciation of the fact of the Earth's movement.
388. (d). *Theophrastus*, author of a history of astronomy. At about this time *Eudemus*, also an historical writer, flourishes.
- 384—322. *Aristotle*, writer on many physical subjects, including astronomy. The Humboldt of Greece.
370. *Eudoxus* introduces into Greece the year of $365\frac{1}{4}$ days.
330. *Calippus* introduces the cycle of 76 years as an improvement on *Meton's*. *Pytheas* measures the latitude of Marseilles, and points out the connexion between the Moon and the tides.
- 323—283. *Euclid* (the school-boy's enemy!), who writes a treatise on celestial phenomena, in which he displays a considerable knowledge of the spherical form of the Earth and of the facts which result therefrom, and also his well-known Elements of Geometry.
- 320—300. *Autolycus*, author of the earliest works on astronomy extant in Greek. About this time *Timocharis* and *Aristyllus* make those observations which afterwards enable Hipparchus to discover and determine the precession of the Equinoxes.
306. First Sun-dial erected at Rome by *Papirius Cursor*.
- 287—212. *Archimedes*, of Syracuse, who observes solstices, and attempts to measure the Sun's diameter: he is however more celebrated as a natural philosopher.
281. *Aratus*, of Cilicia, author of an interesting poem on astronomy, which has been translated into English verse by Lamb.
280. *Aristarchus*, of Samos, author of a work on the magnitudes and distances of the Sun and Moon.
- 276—196. *Eratosthenes*, of Syene, who determines with considerable accuracy the obliquity of the ecliptic, and also the latitude of Alexandria. A measure-

ment of an arc of the meridian between Syene and Alexandria, and other important observations, are attributed to him.

260. *Manetho*, an Egyptian, author of a history now lost.

250±. *Conon*, of Samos, a celebrated astronomer.

220. *Apollonius*, of Perga, author of a treatise on Conic Sections and a planetary theory.

190—120. *Hipparchus*, possibly of Bithynia, the most distinguished of the Greek astronomers. He writes a commentary on Aratus; discovers the precession of the equinoxes; first uses Right Ascensions and Declinations, though afterwards abandons them for longitudes and latitudes; probably invents the stereographic projection of the sphere; determines the mean motion of the Sun and Moon with considerable exactness; suggests a method of determining the Sun's parallax; suspects that inequality of the Moon afterwards discovered by Ptolemy, and known as the Evection; calculates eclipses, and forms the first regular catalogue of stars, &c., &c. Altogether we may fairly call him the Newton of Greece.

135. (b?). *Posidonius*, of Apamea, who attempts to verify Eratosthenes's measure of the Earth. He alleges a connexion between the Tides and the Moon. His works are all lost.

50. *Sosigenes*, of Alexandria, in conjunction with Julius Cæsar, plans the Julian reform of the Calendar.

A.D.

10. *Manilius* writes a poem on astronomy and astrology.

50. *Seneca*, tutor to the Emperor Nero. He writes a work on natural philosophy, which contains many astronomical allusions, more especially to comets; these he surmises to be planets of some kind.

80. *Menelaus* writes treatises on spherical trigonometry, and makes observations at Rome and Rhodes.

117 (?). *Theon*, of Smyrna, makes observations at Alexandria, and writes on astronomy.

... *Cleomedes* writes on astronomy. It is, however, uncertain whether he lived before or after Ptolemy, though probably before.

117 (?). *Geminus*, about the same time as Cleomedes, writes on celestial phenomena.

100—170. Ptolemy, of Alexandria, a well-known observer and writer, author of the celebrated *Μεγάλη Σύνταξις*, called by the Arabians the *Almagest*. This work contains amongst other things a review of the labours of Hipparchus; a description of the heavens and the Milky Way; a catalogue of stars; sundry mechanical arguments against the motion of the Earth; notes on the length of the year, &c. To Ptolemy we owe the discovery of the Lunar Evection, and the refraction of the atmosphere, and a theory of the universe which bears his name.

173. *Sextus Empiricus* writes against Chaldæan astrology.

238. *Censorinus* writes on astrology and chronology.

370. *Julius Firmicus Maternus* writes on astronomy.

383. *Pappus*, of Alexandria, writes a commentary on Ptolemy, all of which is lost.

385. *Theon*, of Alexandria, writes an able commentary on Ptolemy. He leaves some tables, and methods for constructing Almanacs.

415. *Hypatia*, daughter of Theon, the first female on record celebrated for her scientific attainments. Murdered in this year.

470. *Martianus Capella* writes a work called the *Satyricon*, which contains a few astronomical ideas. Amongst others, that Mercury and Venus revolve round the Sun.
500. *Thius*, of Athens, who makes some occultation observations, &c.
546. *Simplicius* writes a commentary on a work of Aristotle, now lost.
550. *Proclus Diadochus* writes a commentary on Euclid, and on the astrology of Aristotle, and shows the method of finding the meridian by equal altitudes.
636. *Isidore*, Archbishop of Hispalis (Seville), who writes on astronomy.
640. Destruction of the Alexandrian School of Astronomy by the Saracens under Omar.
720. *Bede*, who writes an astronomical work.
762. Rise of astronomy amongst the Eastern Saracens, on the building of Bagdad by the Caliph Al Mansur. Amongst this nation astronomy made great progress during the succeeding centuries.
814. The Caliph *Abdalla Al Mamoran*, who began his reign this year, caused measurements to be made in Mesopotamia with the view of arriving at an estimate of the dimensions of the Earth.
880. *Albategnius* or *Albatani*. The most distinguished astronomer between Hipparchus and Tycho Brahe. He discovers the motion of the solar Apogee, corrects the value of precession and the obliquity of the ecliptic; forms a catalogue of stars; first uses sines, chords, &c.
950. *Alfraganus* or *Al-Ferghani* and *Thalet Ben Korrah* both live about this time. The first writes on astronomy; and the second propounds a theory relating to the ecliptic.
986. (d.) *Al-Sâfi*. A distinguished Persian astronomer.
1000. *Ebn Yunis* and *Abùl Wefa* both live about this time. The former is an Egyptian astronomer of merit. He leaves a work containing tables and observations, which displays a considerable knowledge of trigonometry. He is the first to use subsidiary angles. *Abùl-Wefa* is the first to employ tangents, co-tangents, and secants, and is thought by some to have discovered the lunar inequality known as the Variation.
- 1020 (?). *Al-hanen* explains the law of atmospheric refraction.
1050. *Michel Psellus*. The last Greek writer on astronomy of note. *Alphetradius* devises an explanation of the motions of the planets.
1079. *Omar*, a Persian astronomer, proposes to reform the Calendar by interpolating 1 day every 4th year, postponing to the 33rd year the interpolation belonging to the 32nd. This would have produced an error of only 1 day in 5000 years: the Gregorian error is 1 day in 3846 years.
1080. *Arsachel*, a Spanish Moor, constructs some tables. *Alhazen* writes on refraction, and *Geber*, about this time, introduces the use of the co-sine, and makes some improvements in spherical trigonometry.
1200. *Abùl Hassan* forms a catalogue of stars, and makes some improvements in the practice of dialling.
- About this time, or earlier, the Persians construct some tables which were translated by a Greek physician named *Chrysococca*, in the 14th century. The best known, however, are those of *Nasireddin*, published in 1270, under the patronage of Hulagu, grandson of Genghis Khan.
1220. *Sacrobosco* (Anglicè, *Holywood*) writes a work on the sphere, based on Ptolemy; he also writes on the Calendar. About this time *Jordanus* writes on the planisphere.

1230. About this year the *Almagest* is translated into Latin from the Arabic, under the auspices of Frederick II., Emperor of Germany.
1252. *Alphonso X.*, King of Castile, aided, as it is supposed, by certain Moors and Jews, compiles the *Alphonsine Tables*.
1255. *Roger Bacon* writes on astronomy.
1280. *Cocheou-king* makes a number of good observations, and uses spherical trigonometry, under the patronage of Kublai, brother of Hulagu.
1288. Erection of the first important public clock in England, at Old Palace Yard, Westminster.
1433. *Ulugh Beigh*, grandson of Timour or Tamerlane, makes numerous observations at Samarkand, and is especially noted for his catalogue of stars. He also gives tables of geographical latitudes and longitudes.
1440. Cardinal *Cusa* writes on the Calendar.
1460. *George Purbach* publishes trigonometrical tables, and a planetary theory somewhat like that of Ptolemy.
1476. *John Müller*, better known by his Latin name *Regiomontanus*, writes an abridgment of the *Almagest*, and forms some extensive trigonometrical tables and the first Almanac.
1484. *Waltherus* uses a clock with toothed wheels.
1486. *George of Trebizonde*, called *Trapezuntius*, first translates the *Almagest* from the Greek into Latin.
1495. *Bianchini* publishes tables.
1504. (d.) *Waltherus*, a pupil of Regiomontanus, makes numerous observations.
1521. *Riccus* writes a treatise on astronomy, with especial reference to its history.
1528. (d.) *Werner*, who gave a more correct value of the precession of the equinoxes. *Fernel* gives a very correct measure of a degree on the meridian. *Delambre* remarks that it must have been accidental, seeing that his data were very imperfect.
1531. (d.) *Stoffler*, who wrote on the astrolabe and published Almanacs for 50 years.
1543. Publication of Copernicus's *De Revolutionibus Orbium Celestium*, in which is propounded his theory of the solar system, &c. The illustrious author dies in this year.
1552. (d.) *Apian*, who studied comets with great diligence. *Munster* writes on clocks and dials.
1553. (d.) *Rheinhold* (a friend of Copernicus), who constructed the *Prutenic Tables*.
1555. (d.) *Gemma Frisius*.
1556. Dr. *Dee* publishes a book on geometry.
1558. (d.) *Recorde*, said to have been the first modern English writer on astronomy and the sphere.
1571. (d.) *Leonard Digges*, author of *The Prognostication Everlasting*, and other works.
1572. Apparition of a new star in Cassiopeia, whose position is determined by *Hagecius*, by measuring the meridian altitude, and noting the time at which the observation was made.
1573. *Thomas Digges* proposes, as a means for determining the positions of celestial objects, the method of equal altitudes.
1576. (d.) *Rheticus*, editor of the *Opus Palatinum*. Tycho Brahe commences making observations in the island of Hven, in the Baltic, near Copenhagen.

1577. (d.) *Nonius*, inventor of an ingenious division of the circle, sometimes (but erroneously) identified with the "Vernier." Apparition of a comet upon which Tycho Brahe makes observations for the detection of parallax, in which he fails, thus showing that comets traverse regions more removed from the Earth than the Moon.
1581. About this time *Galileo* remarks the isochronism of the pendulum.
1592. (d.) The *Landgrave of Hesse Cassel*, a diligent amateur observer.
1594. (d.) *Gerard Mercator*, author of the projection of the sphere which bears his name.
1595. Thomas Digges, the son of Leonard Digges, publishes a work in this year.
1596. *Fabricius* discovers the variability of α Ceti. Publication of *Kepler's Mysterium Cosmographicum*.
- 1599 or later. (d.) *Rothmann*, who observed comets.
1600. *Jordanus Brunus* is burnt to death at Rome for holding certain opinions on the system of the universe, for instance, that each star is a sun.

After the close of the 16th century, observers and observations begin to multiply so much, that henceforth we shall find it convenient to tabulate the principal astronomers of note, and then to give, in chronological order, an epitome of their labours. The dates are generally those of their deaths, but when that is not known, the date of the publication of some work is given in parentheses.

During the 17th century we have the following:—

Tycho Brahe	1601	De Rheita	(1645)
Scaliger, Jos.	1609	Crabtree	1645?
Clavius	1612	Fontana	(1646)
Calvisius	1615	Longomontanus	1647
Wright	—	Torricelli	—
Fabricius	1616	Descartes	1650
Napier	1617	Scheiner	—
Harriot	1621	Petavius	1652
Bayer	1625	Pascal	1653
Gunter	1626	Gassendi	1655
Snellius	—	Wing	(1661)
Briggs	1630	Lubienitz	(1668)
Malapertius	—	Riccioli	1671
Kepler	—	Borelli	1679
Vernier	(1631)	Dörfel	(1680)
Mœstlin	—	Picard	1682
Lansberg	1632	Hevelius	1687
Schickhardt	1635	Auzout	1693
Horrox	1641	Mercator, N.	1694
Galileo	1642	Bouillaud (Bullialdus)	—
Gascoigne	1644	Huygens	1695

1603. Publication of *Bayer's* Maps of the Stars.
1604. Kepler succeeds in obtaining an approximate value of the correction for refraction. Apparition of a new star in Ophiuchus.
1608. *Hans Lippersheim*, of Middelburg, Holland, invents the refracting telescope, employing a convex object-lens.
1609. Galileo makes a telescope with concave eye-lens. Kepler publishes his work on Mars, in which he determines, by Tycho Brahe's observations, the elliptic form of its orbit, and ratio between the areas and the times, thus enunciating his 1st and 2nd laws.
1610. Galileo announces the discovery of Jupiter's satellites; of nebulæ; of some phenomena in connexion with the appearance of Saturn, afterwards found to proceed from the ring; the phases of Venus; the diurnal and latitudinal libration of the Moon. Harriot observes spots on the Sun.
1611. Foundation of the Lyncean Academy. Galileo and J. Fabricius observe spots on the Sun; the latter discovers its axial rotation.
1614. *Napier* invents logarithms.
1617. *Snellius* measures, by triangulation, an arc of the meridian at Leyden. This is the first recorded instance of the application of trigonometry to geodesy; the results are fairly correct.
1618. Kepler discovers his 3rd law.
1619. *Snellius* discovers the law of refraction from one medium into another.
1626. *Wendelinus* determines the diminution of the obliquity of the ecliptic; extends Kepler's laws to Jupiter's satellites; and ascertains the Sun's parallax.
1627. Kepler publishes his *Rudolphine Tables* based on the observations of Tycho Brahe.
1630. *Zucchi* observes the belts of Jupiter.
1631. *Gassendi* observes the first recorded transit of Mercury over the Sun; and measures the diameter of the planet. *Vernier* describes the instrument which bears his name.
1632. Publication of Galileo's *Dialogues*.
1633. *Norwood* measures an arc of the meridian between London and York. This is the first attempt of the kind in England. *Descartes* promulgates his "System of Vortices." Galileo is forced, by the bigotry of Romish ecclesiastics, to recant his belief in the motion of the Earth.
1635. *Morin* perceives stars in the day-time.
1637. *Horrox* suspects the long inequality in the mean motions of Jupiter and Saturn.
1638. *Horrox* ascribes the motion of the lunar apsides to the disturbing influence of the Sun, and adduces the oscillations of the conical pendulum as an illustration of the planetary movements.
1639. *Horrox* and *Crabtree* observe the first recorded transit of Venus over the Sun, and the former measures the planet's diameter. *Holwarda* notes the variability of *o Ceti*.
1640. *Gascoigne* applies the telescope to the quadrant, and the wire micrometer to the telescope.
1646. *Fontana* observes the belts of Jupiter.
1647. Publication of *Hevelius's Selenographia*, in which is announced the Moon's libration in longitude.

1650. Scheiner constructs a telescope with a convex object-glass.
1651. *Shakerley* observes a transit of Mercury at Surat, in the East Indies.
1654. *Huygens* completes the discovery of Saturn's ring.
1655. Huygens discovers that satellite of Saturn now known as Titan.
1656. Huygens publishes his First Treatise on Saturn. Death of Francesco Fontana.
1657. Foundation of the Academia del Cimento at Florence.
- 1658 (or earlier). Huygens makes the first pendulum clock.
1659. Huygens, ignorant of what Gascoigne had previously done, invents a micrometer, and publishes a second treatise on Saturn. *Childrey* writes on the Zodiacal Light.
1660. *Mouton* applies the simple pendulum to observations of differences of Right Ascension, and by this means obtains a very good measurement of the Sun's diameter. Death of De Rheita.
1661. Hevelius, at Danzig, observes a transit of Mercury.
1662. Foundation of the Royal Society of London. *J. D. Cassini* begins his researches on refraction. *Malvasia* improves Huygens's micrometer.
1663. *Gregory* invents the reflecting telescope which now bears his name.
1664. *Hooke* detects the rotation of Jupiter on its axis. *J. D. Cassini* observes the transit of the shadow of a Jovian satellite.
1665. Cassini determines the time of Jupiter's rotation, and publishes the first Table of the Satellites. *Hooke* proposes the reticulated micrometer for the measurement of lunar distances. Newton invents fluxions.
1666. Cassini determines the rotation of Mars and approximates to that of Venus. Foundation of the Academy of Sciences at Paris. *Auzout*, ignorant of Gascoigne's previous labours, applies the wire-micrometer to the telescope. *Newton* first directs his attention to the question of universal gravitation by considering whether the Moon might not be kept in its orbit by some force akin to terrestrial gravitation.
1667. *Auzout* and *Picard* apply the telescope to the mural quadrant, without knowing that Gascoigne had previously done the same thing. Some Fellow of the Royal Society proposes to employ the seconds' pendulum as an universal unit of length.
1668. Cassini publishes his Second Tables of Jupiter's Satellites, and Hevelius his *Cometographia*.
1669. Newton invents the reflecting telescope which now bears his name.
1670. *Mouton* first uses interpolations in observations.
1671. *Picard* and *La Hire* publish their degree of the meridian, obtained by measuring the arc between Paris and Amiens. *Richer*, in a voyage to Cayenne, observes the shortening of the seconds' pendulum as it is brought towards the equator. *Flamsteed* commences observations at Derby. Cassini begins the observations which lead to his discovery of the inclination of the Moon's equator. He also discovers that satellite of Saturn now known as Iapetus.
1672. Cassini discovers that satellite of Saturn now known as Rhea.
1673. Publication of Huygens's *Horologium Oscillatorium*, in which are found the 5 theories relating to central forces and the first sound explanation of centrifugal force. *Flamsteed* explains the equation of time.
1674. Huygens, ignorant of what Hooke has previously done, causes spring-watches to be made.
1675. *Römer* propounds his discovery relating to the transmission of light, as detected

- by observations on the phenomena of Jupiter's satellites. Foundation of the Royal Observatory, Greenwich. Römer applies the transit instrument to the determination of Right Ascensions.
1676. Flamsteed commences observations at the Royal Observatory, Greenwich.
1677. *Halley* observes, at St. Helena, a transit of Mercury.
1679. Publication of Halley's Catalogue of Southern Stars. Commencement of the *Connaissance des Temps*.
1680. Flamsteed enunciates the law of the Moon's annual equation. Apparition of a celebrated comet, noticeable on account of its very small perihelion distance, and from its having led Newton to the opinion that comets moved in conic sections. Publication of Cassini's Lunar chart.
1681. Publication of *Dörffel's* work on Comets, in which he showed that the orbit of the comet of 1680 was a parabola.
1683. Cassini and La Hire discontinue, till 1700, the arc of the meridian, commenced in 1680. Erection of a mural quadrant in the meridian at the Royal Observatory, Paris. Cassini investigates the Zodiacal Light.
1684. Cassini discovers those satellites of Saturn now known as Tethys and Dione.
1687. Publication of Newton's *Principia*.
1688. Death of Dörffel.
1689. Römer uses the transit instrument for taking time. One Watson, an ingenious man at Coventry, makes the first Orrery, though the name is of later date, having been applied first to an apparatus made by G. Graham about 1700.
1690. Huygens determines, theoretically, the ellipticity of the Earth. Publication of Hevelius's Catalogue of Stars.
1693. Cassini publishes his Third Tables of Jupiter's Satellites, and announces his discoveries on libration. Halley discovers the secular acceleration of the Moon's mean motion.
1694. Newton and Flamsteed commence their correspondence on the subject of the lunar theory and the theory of refraction.
1700. J. D. Cassini, aided by J. Cassini, extends southwards the arc, commenced by himself.

The following is a list of the chief astronomers of note during the 18th century:—

Hooke	1703	Maclaurin	1746
Römer	1710	Bernouilli, J.	1748
Cassini, J. D.	1712	Graham	1751
Leibnitz	1716	Whiston	1755
La Hire, P.	1718	Cassini, James	1756
La Hire, G. P.	1719	Fontenelle	1757
Flamsteed	—	Simpson, T.	1761
Newton	1727	Dollond	—
Maraldi, J. P.	1729	Bradley	1762
Bianchini	—	La Caille	—
Manfredi	1739	Mayer, T.	—
Kirch, C.	1740	Bliss	1764
Halley	1742	Horrebow	—
Hadley	1744	Clairaut	1765

Bird (1766)	Maraldi, J. D. 1788
De L'Isle 1768	Palitzch —
Long 1770	Le Gentil 1792
Harrison 1776	Bailly 1793
Ferguson —	Saron 1794
Lambert 1777	Mudge 1794
Zanotti 1782	Du Séjour —
Wargentin 1783	Pingré 1796
Lexell (—)	Rittenhouse —
D'Alembert —	Maraldi, J. P. 1797
Euler —	Borda 1799
Cassini De Thury, F. ... 1784	Le Monnier —
Lexell —	Cassini, Count (1800)
Boscovich 1787	Ramsden —

1702. La Hire's researches on the theory of refraction.
1704. Römer commences star observations with a meridian circle.
1705. Halley predicts the return in 1759 of the comet of 1682.
1711. Foundation of the Royal Observatory, Berlin.
1714. J. Cassini discovers the inclination of the 5th satellite of Saturn.
1715. *Taylor's* researches on refraction.
1718. *Bradley* publishes his Tables of Jupiter's Satellites. J. Cassini and J. P. Maraldi complete, at Dunkirk, the arc commenced by J. D. Cassini.
1719. Maraldi's researches on the rotation of Jupiter.
1721. Halley communicates to the Royal Society Newton's table of refractions.
1725. Publication of Flamsteed's *Historia Cælestis*. Foundation of the St. Petersburg Observatory. *Harrison* announces the gridiron compensation pendulum.
1726. *Bianchini* determines the rotation of Venus. *Graham* invents the mercurial pendulum.
1727. *Bradley* discovers the aberration of light.
1728. Destruction, by fire, of Copenhagen Observatory, in which were stored the observations of Römer, and of *Horrebow* his successor, all of which are lost.
1729. *Bouguer* investigates the theory of refraction.
1731. *Hadley* invents the Sextant.
1732. J. D. Maraldi improves the theory of Jupiter's satellites. *Maupertuis* introduces into France Newton's theory. *Wright* publishes his Lunar Tables.
1736. *Maupertuis*, *Clairaut*, *Le Monnier*, and others measure an arc in Lapland, and *Bouguer* and *La Condamine* one in Peru.
1737. *La Caille* and *Cassini* (III) re-measure the arc of J. D. Cassini. *Clairaut* improves the theory of the figure of the Earth.
1738. First experiment on the deviation of the plumb-line: at Chimborazo, and probably by *Bouguer*.
1739. Publication of *Dunthorne's* Lunar Tables.
1740. Publication of J. Cassini's Treatise on Astronomy, in which are given many new tables by himself and his father.
1743. *Savary* proposes the divided object-glass micrometer.
1744. Publication of *Euler's Theorium Motuum*, the first analytical work on the planetary motions.

1745. Bradley discovers the nutation of the Earth's axis. *Bird* commences his improvements in the graduation of instruments.
1746. Publication of Euler's Solar and Lunar Tables, and *Wargentin's* Tables of Jupiter's Satellites.
1747. Researches of Euler, Clairaut, and *D'Alembert*, on the theory of the planets. *Mayer* confirms by observation Cassini's theory of the lunar libration.
1748. Bouguer, unacquainted with Savary's discovery, proposes a double object-glass micrometer, which he calls a heliometer. Publication of Euler's Essay on the Motions of Jupiter and Saturn.
1749. Investigations by Euler and *D'Alembert* on precession, by *D'Alembert* on nutation, and by Clairaut on the motion of the lunar apogee. Publication of Halley's Tables.
1750. Mayer introduces the use of equations of condition. *Boscovich* measures an arc of the meridian of Rimini. Publication of Wright's *Theory of the Universe*, in which is propounded that theory of the Milky Way afterwards adopted by Sir W. Herschel.
1751. La Caille goes to the Cape of Good Hope to commence a course of observations.
1752. La Caille measures an arc of the meridian at the Cape of Good Hope.
1754. Publication of Halley's Solar and Lunar Tables by *Chappe*; also of Clairaut's Lunar Tables.
1755. *Dollond* makes a divided object glass micrometer. Mayer first suggests the idea of a repeating circle. Occurrence of a transit of Mercury.
1756. Researches of *D'Alembert* on the figure of the Earth; by Euler on the variation of the elements of elliptic orbits; and by Clairaut on the perturbation of Comets.
1757. Publication of La Caille's *Astronomiæ Fundamenta*.
1758. Publication of La Caille's Solar Tables. Re-invention by *Dollond* of the achromatic object-glass. Researches by Clairaut and *Lalande* on the orbit of Halley's comet.
1759. Publication of Halley's Planetary Tables by *Lalande*. Publication of an improved edition of *Wargentin's* Tables of Jupiter's Satellites.
1760. Bird's Standard Scale.
1761. *Maskelyne* at St. Helena. Transit of Venus.
1762. Researches by Euler and Clairaut on the perturbations of comets.
1764. *Lalande* confirms the observations of Mayer on the lunar libration. Publication of *La Grange's* prize essay on the same subject, containing the first application of the principle of virtual velocities. *Mason* and *Dixon* begin the measurement of an arc in Pennsylvania.
1765. Harrison obtains, after many vexatious delays, the reward promised by Parliament for the invention of the chronometer. J. D. Maraldi discovers the libratory motion of the nodes of Jupiter's 2nd satellite.
1766. Publication by *La Grange*, and also by *Bailly*, of a theory of Jupiter's satellites.
1767. Commencement of the *Nautical Almanac*. Publication of Mayer's *Theoria Lunæ*. He invents the reflecting circle.
1768. *Beccaria* measures an arc of the meridian in Piedmont, and *Liesganig* in Hungary.
1769. Transit of Venus, which is very successfully observed, though the calculations derived from the observations have turned out to be affected by errors.

1770. Publication of Mayer's Solar and Lunar Tables. Discovery of Lexell's comet.
1771. Further researches by Bailly on Jupiter's satellites.
1772. Publication by *Bode* of *Titius's* law of planetary distances.
1773. Researches by *La Grange* on the attraction of spheroids; and by *Laplace* on the secular inequalities of the solar system.
1774. Experiments by *Maskelyne* on the Earth's attraction, on Mount *Schehallien*.
1777. *Rochon* invents the Rock-crystal Micrometer.
1780. Publication of *Mason's* Lunar Tables.
1781. *W. Herschel* discovers the planet *Uranus*. Publication of *Messier's* Catalogue of *Nebulæ*. (*Conn. des Temps*, 1784.) *Wargentin* discovers that the inclination of Jupiter's 4th satellite is variable.
1782. *Laplace* calculates the elements of the orbit of *Uranus*, and investigates the attraction of spheroids.
1783. Publication of *Nouet's* Tables of *Uranus*, and *Pingré's* *Cométographie*.
1784. Researches by *Laplace* on the stability of the solar system; on the relation between the longitudes of Jupiter's satellites; and on the great inequality of Jupiter and Saturn. *Roy* measures a base on *Hounslow Heath* for the connection of the observatories of *Greenwich* and *Paris*.
1786. Publication of *Herschel's* first catalogue of 1000 *nebulæ* (in *Phil. Trans.*). *La Grange* gives the differential equations for the variation of the elliptic elements. *Borda* invents his *Repeating circle*.
1787. *Laplace's* theory of *Saturn's* ring, and explanation of the acceleration of the *Moon's* mean motion. *Herschel* discovers 2 satellites of *Uranus*. *Le Gendre* and *Roy* complete the connection of the observatories of *Greenwich* and *Paris*. Commencement of the *Trigonometrical Survey of England*. *Herschel* commences observations with his 40-foot reflector, and discovers those satellites of *Uranus* now known as *Oberon* and *Titania*.
1788. Publication of *La Grange's* *Mécanique Analytique*. *Herschel* suspects that the motions of the satellites of *Uranus* are retrograde.
1789. *Herschel* determines the rotation of *Saturn*, and discovers the satellites *Mimas* and *Enceladus*. Publication of *Delambre's* Tables of *Jupiter* and *Saturn*.
1790. *Herschel* determines the rotation of *Saturn's* ring, and announces 2 new satellites of *Uranus*, which announcement has never been confirmed. Publication of *Delambre's* Tables of *Uranus*. *Brinkley* appointed *Director* of the *Dublin Observatory*.
1792. Commencement of the *Trigonometrical Survey of France*. Publication of *Taylor's* Logarithms, *Lalande's* improved *Planetary Tables*, and *De Zach's* first *Solar Tables*. *Madras Observatory* founded by *H. E. I. C.*
1793. *Laplace's* researches on the satellites of *Jupiter* and the figure of the *Earth*. *Schröter* determines the rotation of *Venus*.
1795. *Herschel's* observations on variable stars, and the dismemberment of the *Milky Way*.
1796. Foundation of the *French Institute of Science*. *Herschel* suspects that the rotations of the satellites of *Jupiter* are of the same duration as their orbital revolutions. *Oriani* investigates the perturbations of *Mercury*.
1797. *Delambre's* observations on refraction. *Laplace's* theory of tides. *Obers* publishes his method for determining the parabolic elements of a comet's orbit, since generally adopted by *German astronomers*.

1798. *Cavendish* demonstrates and measures the mutual attraction of metal balls. Herschel announces definitely that the satellites of Uranus move in a retrograde direction.
1799. Commencement of Laplace's *Mécanique Celeste*. Occurrence of a transit of Mercury. *Kramp's* researches on refraction.

The following is a list of the chief astronomers of note during the present century:—

Méchain	1804	Damoiseau	—
Lalande, J.	1807	Di Vico	1848
Cavendish... ..	1810	Taylor	—
Maskelyne	1811	Schumacher	1850
La Grange	1813	Boguslawski	—
Messier	1817	Colby	1852
Burekhardt	—	Arago	1853
Mudge	1821	Lindenau	1854
Herschel, Sir W.	1822	Petersen	—
Delambre	—	Mauvais	—
Hutton	1823	Gauss	1855
Bode	1826	Sheepshanks	—
Fraunhofer	—	Colla	1857
Piazzi	—	Raper	1858
Laplace	1827	Bond, W. C.	1859
Wollaston, W.	1828	Brisbane, Sir T. M.	—
Young	1829	Wichmann	—
Fallows	1831	Nicholl	—
Pons	—	Johnson	—
Oriani	1832	Humboldt	—
De Zach	—	Simms, F. W.	—
Groombridge	—	Sonntag	1861
Cassini, Count	—	Daussy	—
Le Gendre	1833	Biot	1862
Harding	1834	Pape	—
Troughton	1835	Jacob	—
Kater	—	Carlini	—
Brinkley	—	Mitchell, O. M.	—
Pond	1836	Rümker, K. C.	—
Gambart	—	Capocci	1863
Moll	1837	Mosotti	—
Rigaud	1839	Trettenero	—
Olbers	1840	Lehmann	—
Poisson	—	Weisse	—
Bouvard	—	Plana	1864
Littrow	—	Struve, W.	—
Cacciatore	1841	Bond, G. P.	1865
Henderson	1844	Gilliss	—
Baily	—	Smyth, W. H.	—
Bessel	1846	Encke	—

Lubbock, Sir J. W. ... —	G. Santini —
Goldschmidt 1866	Main 1878
Hencke —	Secchi —
Everest, Sir G. —	Fletcher, I. 1879
South, Sir J. 1867	Maclear, Sir T. —
Wrottesley, Lord —	Lamont —
Rosse, Earl of —	Peters, C. F. A. 1880
Valz —	Lassell —
Foucault 1868	Peirce, B. —
Dawes —	Dembowski, Baron 1881
Ferguson —	Gautier —
Herschel, Sir J. F. W. 1871	Birt —
Schwerd —	Bruhns —
Laugier 1872	Zöllner 1882
Kaiser —	Challis —
Delaunay —	Robinson, T. R. —
Mrs. Somerville —	Plantamour —
Schweizer 1873	Hornstein —
Chacornac —	Sabine, Sir E. 1883
Donati —	Villarceau —
Maury —	Schmidt, J. F. J. —
Quetelet 1874	Dallmeyer —
Mädler —	Klinkerfues 1884
Hansen —	Kowalski —
Pontécoulant —	Webb 1885
Argelander 1875	Clausen —
D'Arrest —	Oppolzer 1886
Winlock —	Schjellerup 1887
Carrington —	Luther, E. —
Bremiker 1877	Baxendell —
Heis —	Stewart, B. —
Le Verrier —	Proctor 1888
K. L. Von Littrow —	Loomis 1889

- 1798—1804. *Humboldt* travels in America, and makes numerous observations.
1800. Bode's Maps and Catalogue. *Mudge* commences his great arc of the meridian, extending from the Isle of Wight to Clifton in Yorkshire. De Zach starts the *Monatliche Correspondenz*, which goes on for 14 years.
1801. *Piazzi* discovers the minor planet Ceres. *Svanberg* begins to measure an arc in Lapland.
1802. Olbers discovers the planet Pallas. Lambton begins the measurement of an arc in India.
1803. Publication of Herschel's Discovery of Binary Stars.
1804. *Harding* discovers the planet Juno. *Piazzi* publishes the proper motions of 300 stars. De Zach's Solar Tables.
1805. Le Gendre enunciates the method of least squares. Commencement of researches on Stellar Parallax by several observers.
1806. *Méchain* and Delambre complete the French Survey. Publication of Delambre's Solar Tables and Tables of Refraction; of Burg's Lunar Tables; of Carlini's

- Tables of Refraction. Herschel suspects the motion of the whole solar system towards the constellation Hercules. Publication of De Zach's Tables of Aberration and Nutation.
1807. Olbers discovers the planet Vesta. Extension of the French arc into Spain.
1808. Researches of La Grange and Laplace on the Planetary Theory.
1809. *Troughton's* improvements in the graduation of instruments. *Ivory's* Theorems on the Figure of the Earth. Publication of Gauss's *Theoria Motus*.
1810. Groombridge's Refraction Tables. Carlini's Solar Tables. *Lindenau's* Tables of Venus. *Bessel* appointed director of the Observatory of Königsberg.
1811. *Lindenau's* Tables of Mars.
1812. Erection of *Troughton's* Mural Circle at Greenwich. *Burckhardt's* Lunar Tables.
1813. *Lindenau's* Tables of Mercury.
1814. Foundation of the Königsberg Observatory. Commencement of the *Zeitschrift für Astronomie*, which goes on till 1818.
1815. *Bessel's* researches on Precession.
1816. *Lindenau* assigns a new value to the constant of nutation. *Poisson's* researches on Planetary Perturbations.
1817. *Delambre's* Tables of Jupiter's Satellites. *Damoiseau's* researches on Halley's comet.
1818. Publication of *Bessel's Fundamenta Astronomiæ*. De Zach starts the *Correspondance Astronomique*, which goes on till 1825.
1820. Foundation of the Royal Astronomical Society of London. *Reichenbach's* meridian circle erected at Königsberg. Publication of *Brinkley's* Tables of Refraction.
1821. Foundation of the Cape of Good Hope Observatory. Publication of *Bouvard's* Tables of Jupiter, Saturn, and Uranus. The practice of taking circle observations by reflection introduced at the Greenwich Observatory. Researches of *Poisson* on the Precession of the Equinoxes. Commencement of the *Astronomische Nachrichten*, which valuable periodical is still in existence.
1822. Foundation of the Paramatta Observatory, N.S.W. *Argelander's* researches on the orbit of the comet of 1811.
1823. Foundation of the Cambridge Observatory. Researches by *Ivory* on Refraction. *Encke* suspects the existence of a resisting medium in space.
1824. *Encke* discusses the observation of the transits of Venus in 1761 and 1769 for the determination of the solar parallax. Erection of the Dorpat Refractor.
1825. Commencement of the *Berlin Zones*. *Jones's* mural circle erected at Greenwich.
1826. Researches of *Bessel* on the oscillation of the pendulum. Discovery of *Biela's* comet.
1827. The Royal Astronomical Society commences the publication of the *Monthly Notices*.
1828. *Airy* discovers a long inequality in the motions of Venus and the Earth. *Kater's* vertical collimator. Publication of *Damoiseau's* Lunar Tables (2nd ed.).
1829. Researches of *Poisson* on the attraction of spheroids, and of *Pontécoulant* on the orbit of Halley's comet.
1830. Publication of *Bessel's Tabulæ Regiomontanæ*.
1831. Publication of *Plana's Theory of the Moon*, vol. i.

1832. Occurrence of a transit of Mercury. Sir J. Herschel's investigation of the orbits of binary stars. *Don Joaquín de Ferrer* determines the solar parallax from a discussion of the observation of the transit of Venus in 1769.
1833. Airy obtains an important correction in the value of Jupiter's mass. Publication of the results of Lieut. *Foster's* pendulum experiments for determining the ellipticity of the Earth. Sir J. Herschel's Expedition to the Cape.
1834. Sir J. Herschel's researches on the satellites of Uranus. *Lubbock's* theory of the Moon.
1835. Encke commences his researches on Planetary Perturbation. Encke obtains a correction of the value of the solar parallax as deduced from the transits of Venus in 1761 and 1769. Airy determines the time of the rotation of Jupiter. Airy appointed Astronomer Royal. Researches of *Rosenberger* and *Lehmann* on Halley's comet.
1836. Publication of Baily's *Account of Flamsteed*. Publication of Damoiseau's Tables of Jupiter's Satellites.
1837. *Lamont's* researches on the satellites of Uranus. Researches by Pontécoulant on the Lunar Theory. *Henderson* determines the value of the Moon's equatorial parallax. *Argelander's* researches on the motion of the solar system in space. Completion of the great Indian arc of the meridian.
1838. *Lubbock's* researches on the Lunar Theory, Part ii. Bessel determines the parallax of 61 Cygni. *Hansen's* new method of investigating the Lunar Theory. *Robinson* determines the constant of nutation. *Lamont* determines the mass of Uranus.
1839. Commencement of *Le Verrier's* researches on the theories of the planets. *Henderson* determines the parallax of α Centauri. Foundation of the Imperial Observatory at Pulkova. Johnson appointed director of the Radcliffe Observatory, Oxford. *Amici's* double-image micrometer.
1840. Foundation of the Cambridge (U.S.) Observatory. Airy's double-image micrometer.
1841. Erection of Repsold's meridian circle at Königsberg. Researches of Hansen on the Lunar Theory.
1842. Foundation of the National Observatory, Washington (U.S.). *C. A. F. Peters* determines the constant of nutation; *Baily* determines the mean density of the Earth by a repetition of the Cavendish experiment.
1843. Hansen's new method of investigating the effects of planetary perturbation, whatever be the eccentricity or inclination of the orbit. *Schwabe* detects a periodicity in the solar spots. W. Struve determines the constant of aberration. *Adams* commences his investigation on the orbit of Uranus which ultimately leads to the discovery of Neptune. *Le Verrier's* theory of Mercury.
1844. *Sheepshanks* commences his researches to determine the length of the standard yard, which he continues till his death in 1855. *Argelander* concludes his zone observations north of Decl. + 45. Transmission of time by means of electric signals commenced in the United States. Publication of *Smyth's Cycle of Celestial Objects*.
1845. Discovery of a new minor planet Astræa: in subsequent years many others are detected. Researches of *Le Verrier* on the theories of Mercury and Uranus. Death of Cassini the IVth, æt. 97.

1846. Airy's measurement of the arc of parallel comprised between Valencia and Greenwich. Discovery of the planet Neptune. Publication of the results of the observations of the planets made at Greenwich between 1750 and 1830.
1847. Erection of the altazimuth at Greenwich. Hansen discovers 2 long inequalities in the Moon's motion. Publication of Sir J. Herschel's *Results of Astronomical Observations made at the Cape of Good Hope* in 1833 and following years; of W. Struve's *Études d'Astronomie Stellaire*. Researches of Galloway on the motion of the solar system. Lassell discovers the satellite of Neptune, and that satellite of Uranus since called Ariel, whilst O. Struve discovers Umbriel.
1848. Researches of *Challis* for determining the orbit of a planet or comet. Lassell in England and *W. C. Bond* in America discover independently an 8th satellite of Saturn, since called Hyperion. Researches of *Wichmann* on the physical libration of the Moon, and of C. A. F. Peters on stellar parallax.
1849. *Shortrede's* logarithms. Researches of *Powell* on irradiation. *Main* confirms the opinion of Bessel as to the strictly elliptical form of Saturn.
1851. Researches of C. A. F. Peters on the variability of the proper motion of Sirius. Pendulum experiments of *Foucault* for demonstrating the rotation of the Earth. Discovery of the dusky ring of Saturn. Erection of a new transit circle at Greenwich. Completion of the Russo-Scandinavian arc of the meridian. Dr. *Gould* starts in America the *Astronomical Journal*. *Ötzen* commences the reduction of Argelander's zones, extending from 45° to 89° of north declination, which he finishes in the following year.
1852. Commencement of zone observations at the Cambridge (U.S.) Observatory. Researches of *Villargeau* on the orbits of double stars. Researches of *Secchi* on the Earth's temperature. Observations with the reflex zenith-tube commenced at Greenwich.
1853. Researches of Airy on ancient eclipses; of Adams on the secular inequality in the Moon's mean motion; of Hansen on the theory of the pendulum. Publication of the American Lunar Tables. Encke gives a new solution to the problem of Planetary Perturbation. Hansen's Solar Tables.
1854. The chronographic method of recording transits introduced at Greenwich. Researches of Lubbock on refraction. Airy's pendulum experiments in the Harton Colliery for determining the density of the Earth. Determination of the difference of the longitude of Greenwich and Paris by electric signals.
1855. Researches of Main on the value of the constants of aberration and nutation, and on the rings of Saturn. Commencement of the publication of the *Annales* of the Paris Observatory, of the *American Nautical Almanac*, and of *Brünnow's Tables of Flora*.
1856. Researches of *Challis* on the problem of the 3 bodies; of Main on the diameters of the planets. Astronomical expedition to Teneriffe under *C. P. Smyth*.
1857. Researches of Airy on ancient eclipses. Publication of Hansen's Lunar Tables. *De La Rue*, *Secchi*, *Bond*, and others, obtain photographs of celestial objects. *Hock's* investigation of the identity of the comets of 976 and 1556.

1858. De La Rue obtains a stereoscopic photograph of the Moon. Publication of Le Verrier's Solar Tables. Erection of a photoheliograph at the Kew Observatory. Occurrence of an annular eclipse which excited much interest in England. Donati's comet. Completion of the calculations for determining the principal triangles of the Trigonometrical Survey of the British Isles, and deduction of final results relating to the figure, dimensions, and density of the Earth.
1859. Completion of Le Verrier's theory of Mercury. Suspected discovery of a new planet revolving within the orbit of Mercury, and since named Vulcan. Numerous spots visible on the Sun during the summer months. Completion of the Berlin Star Charts commenced in 1830. Researches by Airy on the motion of the solar system.
1860. Erection of a fine achromatic Equatorial at the Greenwich Observatory. Occurrence of a total eclipse of the Sun visible in Spain, to observe which a large party of astronomers sail from England in H. M. S. *Himalaya*, besides other parties from France, &c.
1861. Discovery of many new planets. Apparition of 2 comets visible to the naked eye, of which the 2nd, which appeared in June, had the longest tail on record—105°. Le Verrier's theories of Venus and Mars.
1862. Lunar computations for the *Nautical Almanac*, conducted with Hansen's Tables. Publication of G. P. Bond's magnificent monograph on Donati's comet of 1858.
1863. Announcement by several computers that the received value of the solar parallax is too small by about $\frac{3}{10}''$. Researches by Airy and Dunkin on the motion of the solar system. Commencement of the *Astronomical Register*—the first English periodical exclusively devoted to astronomy. Spectrum observations of celestial objects by Huggins and Miller. Publication of Carrington's observations on Solar Spots.
1864. Balloon ascents by *Glaisker*.
1865. Important spectrum observations by Huggins, Miller, Secchi, and others.
1866. Apparition of a very striking temporary (or variable?) star in Corona Borealis. Recurrence of a maximum in the November Periodic Meteors, which resulted in a display of remarkable beauty, attracting general public notice.
1867. Completion by *Cooke* for R. S. Newall of the largest object-glass up to that time made, the diameter being 25 inches and the focal length 29 feet. Adams proves the identity of the November meteors with Tempel's comet.
1868. Important total eclipse of the Sun on August 18 visible chiefly in the East Indies. Red prominences observed on the Sun spectroscopically by *Lockyer* and *Janssen* independently and irrespective of the Sun being eclipsed. Publication of elaborate engravings of the great nebula in Orion by the Earl of Rosse and Mr. Lassell.
1869. Important total eclipse of the Sun on August 7, visible chiefly in North America. Experiments by the *Earl of Rosse* at Parsonstown, and by *M. Marie-Davy* at Paris, on the radiation of heat from the Moon.
1870. Total eclipse of the Sun on December 22 visible in Spain and Sicily; the expedition was conveyed in her H. M. S. *Urgent*.
1871. Spectroscopic observations on the Sun by *Young*. Publication of *Williams's* Catalogue of Chinese comets. *Zöllner's* Reversion Spectroscope. Chrono-

- graphic determination of the difference of longitude between London and Teheran through 3870 miles of wire.
1872. Researches by Huggins on the motions of Stars in the line of sight. Le Verrier's theory of Jupiter.
1873. Completion of *J. F. J. Schmidt's* Map of the Moon after 34 years' labour. Further researches by the Earl of Rosse on the radiation of heat from the Moon. Galle suggests observations of the minor planets for the determination of the Sun's parallax. *Newcomb's* tables of Uranus. Le Verrier's theory of Saturn.
1874. Coggia's comet. Transit of Venus on December 8, for which enormous preparations were made all over the world. Completion of Le Verrier's Planetary researches by the publication of the theories of Uranus (revised) and Neptune. Publication of *Cornu's* investigations respecting the velocity of light. The Royal Astronomical Society of London moves from Somerset House to Burlington House.
1876. Unprecedented absence of spots on the Sun.
1877. Discovery of the 2 satellites of Mars by A. Hall.
1878. Red spot on Jupiter. Publication by the Russian Government of Schmidt's great Map of the Moon.
1879. No fewer than 20 minor planets discovered, the largest number ever found in any one year.
1881. Two bright comets visible to the naked eye in July.
1882. Transit of Venus on Dec. 6. Large comet visible in September.
1884. A Conference at Washington adopts Greenwich as the Prime Meridian.
1885. Temporary star visible in the great nebula in Andromeda.
1887. Completion of the great 36-inch Refractor of the Lick Observatory. An International Conference at Paris agrees on a scheme to photograph the whole Heavens.
1888. Publication of the result of Pickering's photometric researches into the brilliancy of 4143 stars.
1889. Important total eclipse of the Sun on Jan. 1, well observed in many parts of North America.

BOOK XII.

ASTRONOMICAL BIBLIOGRAPHY.

CHAPTER I.

LIST OF PUBLISHED STAR CATALOGUES AND CELESTIAL CHARTS^a.

THE following is a list of all the principal Catalogues of Stars and other celestial objects which have ever appeared. The dates prefixed are in most cases those of actual publication, and where the works cited were issued in a separate form, the titles are as far as possible given in such a way as to enable intending purchasers living at a distance to notify in intelligible terms their wants to their booksellers^b.

CATALOGUES OF ISOLATED STARS.

B.C.

128. HIPPARCHUS. [Contains 1025 stars (excluding duplicates), observed at Rhodes, incorporated by Ptolemy into his *Μεγάλη Σύνταξις*, or *The Almagest*, and by him reduced to the epoch of 137 A.D. Last edition by Baily, in *Memoirs R.A.S.*, vol. xiii. p. 1. 1843. For a possible explanation of Ptolemy's Catalogue being so erroneous, see note by Drayson, *Month. Not.*, vol. xxviii. p. 207. May 1868.]

^a This list is not intended to include every work issued, but merely the *principal*. The Catalogue of the library of the Pulkova Observatory (in W. Struve's *Description de l'Observatoire Astronomique Central*, fol., St. Petersburg, 1845) will be found useful to the bibliographer. A new edition was published as a separate volume in 1860, under the title of *Librorum . . . Catalogus Systematicus*, and in 1880 a continuation appeared as *Pars Secunda*. The large *Bibliographie Générale* of MM. Houzeau and Lancaster,

published in 1882, is also a work of great interest and value. A very useful *Reference Catalogue* of literary materials relating to Sidereal Astronomy, by E. B. Knobel, will be found in *Month. Not.*, vol. xxxvi. p. 365. 1876.

^b Marked thus (*) are works which I have not had an opportunity of personally consulting, and the titles are therefore given at second-hand, and may be inexact. Every other work named in this chapter has been examined by myself.

A.D.

- 950 *circa*. ABD-AL-RAHMAN AL-SUFI. [A description of the heavens by a Persian Astronomer of Bagdad. Translated from Arabic into French and edited by H. C. F. C. Schjellerup as *Description des Étoiles Fixes*. 4to. St. Petersburg, 1874.]
- *— ABUL HASSAN ALI. [Contains 240 stars reduced to 622 A.D. Last edition by J. J. Sédillot. Paris, 1834.]
1437. ULUGH BEIGH. [Contains 1019 stars observed at Samarcand. Last edition by Baily, in *Memoirs*, R.A.S., vol. xiii. p. 79. 1843.]
1602. TYCHO BRAHE, *Catalogus Stellarum Fixarum*. [Contains 777 stars observed at Uraniburg, reduced to the year 1600. 2nd edition, containing altogether 1005 stars, published by Kepler in 1627. Last edition by Baily, in *Memoirs* R.A.S., vol. xiii. p. 127. 1843.]
1618. WILLIAM, LANDGRAVE OF HESSE, aided by Rothmann and Byrgius, *Catalogus Stellarum Fixarum*. [Contains 368 stars; reduced to the year 1593. Last edition by Flamsteed, in *Hist. Cælest.*, vol. iii. p. 24. Fol. London, 1725.]
- *1624. BARTSCHUIS, JACOBUS, *Planisphærium*. [Contains 136 southern stars; see remarks by Baily in *Memoirs* R.A.S., vol. xiii. p. 34. 1843.]
1679. HALLEY, *Catalogus Stellarum Australium*. [Contains 341 southern stars observed at St. Helena, reduced to 1677. Last edition by Baily, in *Memoirs* R.A.S., vol. xiii. p. 167. 1843.]
1690. HEVELIUS, J., of Danzig, *Catalogus Stellarum Fixarum*. [Contains 1564 stars, reduced to 1660 (end of). In his *Prodromus Astronomiæ*. Last edition by Baily, in *Memoirs* R.A.S., vol. xiii. p. 183. 1843.]
1725. FLAMSTEED, Rev. JOHN, *Catalogus Britannicus*. [In the *Historia Cælestis*. Contains 3310 stars observed at Greenwich, and reduced to 1690. Last edition, considerably enlarged, by Baily in *Account of Flamsteed*. 4to. London, 1835.]
1725. SHARP, ABRAHAM. [Contains 265 southern stars observed at St. Helena; reduced to 1726. Published in Flamsteed's *Hist. Cælest.*, iii. Fol. London, 1725.]
1757. LA CAILLE, N. L. [Contains 398 stars; reduced to Jan. 1, 1750. Published in his *Fundamenta Astronomiæ*. Last edition by Baily, in *Memoirs* R.A.S., vol. v. p. 93. 1833. Imperfect editions of this are in circulation: see Vince's *Astronomy*.]
- *1763. LA CAILLE, N. L. [Contains 515 zodiacal stars; reduced to 1765. Edited, very carelessly, by Bailly, of Paris, and published in *Ephémérides des Mouvements Célestes*. 1765-75.]
1763. LA CAILLE, N. L., *Cælum Australe Stelliferum*. 4to. Paris. [Contains 1942 southern stars observed at the Cape.]
1773. BRADLEY, Rev. J. [Contains 389 stars observed at Greenwich; reduced to 1760. Published in the *Nautical Almanac*. 1773. Republished in 1798, by Hornsby, in his edition of Bradley's *Obs.*, vol. i. p. xxxviii.]
1774. MASKELYNE, Rev. N. [Contains 34 stars observed at Greenwich; reduced to 1770. Published in Maskelyne's *Greenwich Obs.*, vol. i., Appendix of Tables, p. 5.]
1775. MAYER, T. [Contains 998 stars observed at Göttingen; reduced to 1756. Edited by Lichtenberg, and published at Göttingen in Mayer's *Opera Inedita*. Last edition by Baily, in *Memoirs* R.A.S., vol. iv. p. 391. 1831.]
1786. FIGOTT, E., *Observations and Remarks on Stars . . . suspected to be changeable*

- Phil. Trans.*, vol. lxxvi. p. 189. 1786. [Contains 50 stars known or suspected to be variable.]
- *1792. DE ZACH, *Fixarum Præcipuarum Stellarum Catalogus Novus*. 4to. Gotha. [Contains 381 stars; reduced to 1800.0.]
1798. HERSCHEL, W., *Catalogue of Flamsteed Stars*. Fol. Lond. [Contains stars selected from vol. ii. of Flamsteed's *Historia Cælestis*, with notes by Sir W. Herschel and Errata by Miss C. Herschel.]
1800. WOLLASTON, Rev. F., *Catalogue of Circumpolar Stars* (260), reduced to 1800.0. 4to. Lond. [In the author's *Fasciculus Astronomicus*.]
1801. LALANDE, J. DE, *Catalogue*. [Contains 47,390 stars; reduced to 1800. Published in the *Histoire Cæleste Française*. Last edition by Bailly, for the British Association. 8vo. Lond., 1847.]
- *1803. CAGNOLI, A., *Catalogo di Stelle Boreali*. Published in *Mémoires de la Société Italienne des Sciences*, vol. x. [Contains stars observed at Modena.]
1803. PIAZZI, G., *Præcipuarum Stellarum inerrantium Positiones Mediæ*. Fol. Panormi. [Contains 6748 stars observed at Palermo; reduced to 1801.]
- *1805. BODE, J. E., *Catalogue de l'ascension droite et de la déclinaison de 5505 étoiles*. 4to. Berlin. [Contains 5505 stars observed by Piazzi at Palermo and 372 nebulae and clusters.]
- *1806. DE ZACH. [Contains 1830 zodiacal stars observed at Seeberg.]
1807. CAGNOLI, A., *Catalogue de 501 Étoiles*. [Observed at Modena. 8vo. Modène.]
- *1807. PIAZZI, G. [Contains 120 stars.]
1814. PIAZZI, G., *Præcipuarum Stellarum inerrantium Positiones Mediæ*. 4to. Panormi. [Contains 7646 stars observed at Palermo; reduced to 1801.0. A sort of second edition of the Catalogue of 1803.]
1818. BRADLEY, Rev. J. [Contains 3222 stars observed at Greenwich; reduced to Jan. 1, 1755. Published by Bessel in his *Fundamenta Astronomiæ*. Fol. Regiomonti.]
1818. POND, J., *Catalogue*. [Contains 400 stars; reduced to 1817.0. Published in *Greenwich Obs.*, 1814-16.]
- *1819. BESSEL, F. G. W., *Fundamentalsterne*. [Contains 36 important stars; reduced to 1815.0.]
1824. FALLOWS, Rev. F., *Catalogue of the Principal Fixed Stars*. *Phil. Trans.*, vol. cxiv. p. 457. 1824. [Contains 273 southern stars observed at the Cape of Good Hope; reduced to 1824.0.]
1827. ASTRONOMICAL SOCIETY OF LONDON, *Catalogue of the Principal Stars*. *Mémoires R.A.S.*, vol. ii. App. 1827. [Contains 2881 stars compiled from various sources; reduced to 1830.0.]
1827. BAILY, F., *Catalogue of Zodiacal Stars*. 8vo. [Contains 1202 stars to the 7th magnitude, within 10° of the Ecliptic, selected from the *Ast. Soc. Catalogue*; reduced to 1830.0.]
1829. POND, J., *Catalogue*. [Contains 720 stars observed at Greenwich; reduced to 1830.0. Published in *Greenwich Obs.*, 1829.]
1832. RÜMKER, C., *Preliminary Catalogue of Fixed Stars*. 4to. Hamburg. [Contains 632 southern stars; reduced to 1827.0.]
1833. POND, J., *Catalogue of 1112 Stars*. Fol. Lond. [Stars observed at Greenwich; reduced to 1830.0.]
1833. BAILY, F., *List of 314 Stars known or supposed to have an annual proper motion exceeding 0.5" of a great circle*. *Mémoires R.A.S.*, vol. v. p. 158. 1833.

1835. ARGELANDER, F. G. A., *DLX. Stellarum Fixarum Positiones Medix*. 4to. Helsingforsia. [Contains 560 stars observed at Abo; reduced to 1830-o.]
1835. BRISBANE, Sir THOMAS, *Catalogue of 7385 Southern Stars*. [Observed at Paramatta, N.S.W. Ed. by W. Richardson. 4to. Lond.]
1835. JOHNSON, Lieut. M. J., *Catalogue of 606 Principal Fixed Stars in the Southern Hemisphere*. [Observed at St. Helena; reduced to 1830-o. Published by the H. E. I. Co. 4to. Lond.]
1838. GROOMBRIDGE, S., *Catalogue of Circumpolar Stars*. [Contains 4243 stars. 4to. Lond. Reduced to 1810-o. Edited by Airy.]
1838. HENDERSON, T., *Declinations of Principal Fixed Stars (172)*. [Chiefly in the southern hemisphere; reduced to 1833-o.] *Memoirs R.A.S.*, vol. x. p. 49. 1838.
1838. WROTTESELEY, Lord, *Right Ascensions of 1318 Stars*. [Observed at Blackheath; reduced to 1830-o.] *Memoirs R.A.S.*, vol. x. p. 157. 1838.
1840. AIRY, G. B., *Catalogue of 727 Stars*. [Observed at Cambridge; reduced to 1830-o.] *Memoirs R.A.S.*, vol. xi. p. 21. 1840.
- *1840. SANTINI, G., *Positioni medie delle Stelle Fisse*, part i. stars (1744) from 0° to $+12^{\circ}$; part ii. stars (2348) from 0° to -12° ; observed at Padua; reduced to 1840-o. 4to.
1842. WROTTESELEY, Hon. J., *A Supplemental Catalogue of the Right Ascensions of 55 Stars*. [Reduced to 1830-o.] *Memoirs R.A.S.*, vol. xii. p. 103. 1842.
1842. SANTINI, G., *Catalogue of 1677 Stars between the Equator and $+10^{\circ}$* . [Observed at Padua; reduced to 1840-o.] *Memoirs R.A.S.*, vol. xii. p. 273. 1842.
- *1843-52. RÜMKER, C., *Mittlere Örter von 12,000 Fixsternen*. Oblong 4to. Hamburg. [Contains 11,978 stars observed at Hamburg; reduced to 1836-o.]
1844. HENDERSON, T., *Right Ascensions of the Principal Fixed Stars*. [Contains 174 stars; reduced to 1833-o.] *Memoirs R.A.S.*, vol. xv.
1844. AIRY, G. B., *Catalogue of the places of 1439 Stars*. [Observed at Greenwich; reduced to 1840-o. Published in *Greenwich Obs.*, 1842, and separately.]
1844. TAYLOR, T. G., *General Catalogue of the Principal Fixed Stars*. 4to. Madras. [Contains 11,015 stars observed at Madras: reduced to 1835-o.]
1845. BRITISH ASSOCIATION, *Catalogue of Stars*. 4to. Lond. [Contains 8377 stars, compiled from various sources; reduced to 1850-o. Edited chiefly by Baily. This is commonly considered to be the most useful catalogue ever published, but it is now much out of date.]
1846. BESSEL, *Positiones Mediæ Stellarum Fixarum*. 4to. Petropoli. [Part i, between -15° and $+15^{\circ}$ equatorial regions of declination, containing 31,085 stars observed at Königsberg; reduced to 1825, by Weisse, at the expense of the Academy of Sciences of St. Petersburg, and edited by W. Struve.]
1846. PEARSON, Rev. W., *Catalogue of 520 Stars within 6° N. and S. of the Ecliptic*. [Reduced to 1830-o.] *Memoirs R.A.S.*, vol. xv. p. 97. 1846.
1847. LA CAILLE, *Catalogue of 9766 Stars in the Southern Hemisphere*. 8vo. Lond. [Contains stars observed at the Cape of Good Hope; reduced to 1750-o. The reductions were carried on under the superintendence of Henderson, at the expense of H.M. Government.]
1848. TAYLOR, T. G., *Mean Places of 97 Principal Fixed Stars*. 4to. Madras. [Contains stars observed at Madras, 1843-7; reduced to 1845.]

1849. AIRY, G. B., *Catalogue of 2156 Stars*. [Observed at Greenwich; reduced, some to 1840.0, the remainder to 1845.0. Published in *Greenwich Obs.*, 1847. Commonly called the *Greenwich 12-Year Catalogue*.]
1851. FALLOWS, Rev. F., *Catalogue*. [Contains 425 stars, observed at the Cape of Good Hope; reduced to 1830.0. Edited by Airy.] *Memoirs R.A.S.*, vol. xix. p. 77. 1851.
1851. MAIN, Rev. R., *Proper Motions* [of 877 stars observed at Greenwich]. *Memoirs R.A.S.*, vol. xix. p. 121. 1851.
- 1851-6. COOPER, E. J., *Catalogue of Stars near the Ecliptic*. 4 vols. 8vo. Dublin. [Observed at Markree in the years 1848-56: contains 60,066 stars.]
1852. ARGELANDER, F. G. A., and ÖLTZEN, W., *Zonen-Beobachtungen vom 45° bis 80° Nördlicher Declination*. [Contains 26,425 stars; reduced to 1842.0. Published in the *Annalen* of the Vienna Observatory. 8vo. Vienna.]
- *1853. JACOB, W. S., *A Subsidiary Catalogue of 1440 B. A. C. Stars*. [Observed at Madras; reduced to 1850.0.]
1854. FEDORENKO, I., *Positions Méryennes des Étoiles circompolaires*. 4to. St. Pétersbourg. [Contains 4673 circumpolar stars, from Lalande; reduced to 1790.0.]
- *1854. TAYLOR, T. G., *Catalogue of 1440 Stars, selected from the British Association Catalogue*. Madras. [From observations made at Madras, 1849-53.]
1854. WROTTESELEY, Lord, *A Catalogue of the Right Ascensions of 1009 Stars*. [Observed at Wrottesley; reduced to 1850.0.] *Memoirs R.A.S.*, vol. xxiii. p. 1. 1854.
1855. BOND, W. C., (1) *A Standard Catalogue of 1123 Stars* [between 0° and +1° of Decl.]: (2) *Zone Observations* [of 5500 stars between the equator and +0° 20' of Decl.]. *Annals of Harvard Coll. Obs.*, vol. i. 4to. Cambridge, U.S.
1856. AIRY, G. B., *Catalogue of 1576 Stars*. [Observed at Greenwich; reduced to 1850.0. Published in *Greenwich Obs.*, 1854.]
1856. MÄDLER, J. H., *Catalog der 3222 Bradleyschen Sterne*. [Contains proper motions of all, and concluded Mean Places for 1850.0 derived from many standard catalogues; also nominal lists of all the stars from mags. 1-5 grouped in magnitudes. Published in vol. xiv. of the Dorpat *Beobachtungen*. 4to. Dorpat, 1856.]
1856. POGSON, N., *Catalogue of 53 known Variable Stars*. *Radcliffe Observations*. vol. xv. [Stars reduced to 1860.0.]
1857. CARRINGTON, R. C., *Catalogue of 3735 Circumpolar Stars observed at Redhill*. Fol. Lond. [Reduced to 1855.0. Printed at the expense of H. M. Government.]
1857. SCHWERD, G., *Stars observed at Speyer*. Printed at the end of Carrington's *Redhill Catalogue*. Fol. Lond. [Contains 680 circumpolar stars; reduced to 1828.0 and 1855.0; further revised by Oeltzen.]
1858. SANTINI, G., *Posizioni medie di 2706 Stelle*. 4to. Venezia, 1858. [Contains stars between -10° and -12° 30'; reduced to 1860. Republished from *Memorie dell' Istituto Veneto di Scienze*, vol. vii.]
1859. ARGELANDER, F. G. A., *Bonner Sternverzeichniss, Erste Section*. 4to. Bonn. [Published in vol. iii. of the *Beobachtungen* of the Bonn Observatory: contains 110,984 stars, between -2° and +20°, observed at Bonn; reduced to 1855.0.]

1859. ROBINSON, Rev. T. R., *Places of 5345 Stars observed at Armagh*. 8vo. Dublin. [Reduced to 1840-0. Printed at the expense of H. M. Government.]
1859. MOESTA. [Contains 999 stars observed at Santiago de Chile; reduced to 1855-0.] Published in vol. i. of the *Observaciones* of the Santiago Observatory.
1859. RÜMCKER, C., *Neue Folge Mittlerer Oerter von Fixsternen*. Hamburg. [Contains 3126 stars; reduced to 1850-0.]
1860. JACOB, Capt. W. S., *Catalogue of 317 B. A. C. Stars*. [Observed at Madras, for proper motions; reduced to 1855-0.] *Memoirs R.A.S.*, vol. xxviii. p. i. 1860.
1860. JOHNSON, M. J., *The Radcliffe Catalogue of 6317 Stars, chiefly Circumpolar*. 8vo. Oxford. [Stars observed at Oxford; reduced to 1845-0. Edited by the Rev. R. Main. This may be regarded as one of the most valuable catalogues published.]
1860. MAIN, Rev. R., *Proper Motions* [of 270 stars observed at Greenwich]. *Memoirs R.A.S.*, vol. xxviii. p. 127. 1860.
1861. ARGELANDER, F. G. A., *Bonner Sternverzeichniss, Zweite Section*. 4to. Bonn. [Published in vol. iv. of the *Beobachtungen* of the Bonn Observatory: contains 105,075 stars, between $+20^{\circ}$ and $+41^{\circ}$, observed at Bonn; reduced to 1855-0.]
1861. SAFFORD, T. H., *Catalogue of the Declinations of 532* [zenith of Cambridge (U.S.)] *Stars*. *Memoirs Amer. Acad.*, vol. viii. part i. p. 299. 1861. [Contains numerous titles of catalogues.]
1862. ARGELANDER, F. G. A., *Bonner Sternverzeichniss, Dritte Section*. 4to. Bonn. [Published in vol. v. of the *Beobachtungen* of the Bonn Observatory: contains 108,129 stars, between $+41^{\circ}$ and $+90^{\circ}$, observed at Bonn; reduced to 1855-0.]
1862. SANTINI, G., *Posizioni medie di 2246 Stelle*. 4to. Venezia, 1862. [Contains stars between $-12^{\circ} 30'$ and -15° ; reduced to 1860-0. Republished from *Memorie dell' Istituto Veneto di Scienze*, vol. x.]
1863. BESSSEL, F. G. W., *Positiones mediæ Stellarum Fixarum*. 4to. Petropoli. [Partii, stars between $+15^{\circ}$ and $+45^{\circ}$; contains 31,445 stars observed at Königsberg: reduced to 1825, by Weisse, at the expense of the Academy of Sciences of St. Petersburg, and edited by O. Struve.]
1863. SAFFORD, T. H., *Catalogue of Standard Polar and Clock Stars*. *Memoirs Amer. Acad.*, vol. viii. part ii. p. 537. 1863. [Contains 121 stars reduced to 1855-0.]
1864. AIRY, G. B., *Greenwich 7-Year Catalogue*. [Contains 2022 stars observed at Greenwich. Published in App. to *Greenwich Obs.*, 1862.]
1864. SCHJELLERUP, H. C. F. C., *Stjernefortegnelse*. 4to. Kjøbenhavn. [Contains 10,000 stars, between -15° and $+15^{\circ}$, observed at Copenhagen.]
1865. CHAMBERS, G. F., *Catalogue of Variable Stars*. *Month. Not.*, vol. xxv. p. 208. May 1865. [Contains 128 stars, reduced to 1870-0.]
1866. LAMONT, J., *Verzeichniss von Äquatorial-Sternen*. [Contains 9412 stars between -3° and $+3^{\circ}$ of decl.; reduced to 1850. Published as *Supplementband* No. 5 to the *Annalen der Münchener Sternwarte*. 8vo. München.]
1867. SCHJELLERUP, H. C. F. C., *Genäherte Örter der Fixsterne*. [Contains 6983 stars (various) mentioned in vols. 1-66 of *Ast. Nach.*] *Publication der Astronomischen Gesellschaft*, no. viii.
1867. ARGELANDER, F. G. A., *Mittlere Oerter von 33,811 Sternen*. 4to. Bonn. [Pub-

lished in vol. vi. of the *Beobachtungen* of the Bonn Observatory: contains stars observed at Bonn 1845-67; reduced to 1855.0.]

- *1869. COPELAND, R., and BÖRGEN, C., *Mittlere Oerter der in den Zonen 0° und -1° der Bonner Durchmusterung enthaltenen Sternen*. [Contains 6595 stars to 9^{th} mag. observed at Göttingen; reduced to 1875.]
1869. ELLERY, R. J., *Williamstown Catalogue of 546 Stars for 1860*. [Published in *Astronomical Observations made at Williamstown, 1861-63*.]
1869. LAMONT, J., *Verzeichniss von telescopischen Sternen*. [Contains 6323 stars between $+3^{\circ}$ and $+9^{\circ}$; reduced to 1850. Published as *Supplementband No. 8* to the *Annalen der Münchener Sternwarte*. 8vo. München.]
1869. LAMONT, J., *Verzeichniss von telescopischen Sternen*. [Contains 4793 stars between -3° and -9° ; reduced to 1850. Published as *Supplementband No. 9* to the *Annalen der Münchener Sternwarte*. 8vo. München.]
- *1869. STRUVE, O., *Ascensions droites moyennes des Étoiles principales*. St. Petersburg. [Contains 374 principal stars observed at Pulkova, 1842-53; reduced to 1845.0.]
1870. MAIN, Rev. R., *The Second Radcliffe Catalogue*. 8vo. Oxford. [Contains 2386 stars observed at Oxford; reduced to 1860.]
1870. AIRY, G. B., *New 7-Year Catalogue*. [Contains 2760 stars observed at Greenwich; reduced to 1864.0. Published in App. to *Greenwich Obs.* 1868.]
1870. TRETENERO, *Posizioni medie di 1425 Stelle*. 4to. Venezia, 1870. [Contains stars between 0° and -3° ; reduced to 1860. Edited by Santini. Republished from *Memorie dell' Istituto Veneto di Scienze*, vol. xv.]
- *1870. GILLIS, J. M. [Contains 1963 stars and 290 double stars, chiefly southern; reduced to 1850.0. Published as an Appendix to the *Washington Observations*, 1868.]
1871. LAMONT, J., *Verzeichniss von telescopischen Sternen*. [Contains 3571 stars between $+9^{\circ}$ and $+15^{\circ}$; reduced to 1850. Published as *Supplementband No. 11* to the *Annalen der Münchener Sternwarte*. 8vo. München.]
1872. LAMONT, J., *Verzeichniss von telescopischen Sternen*. [Contains 4093 stars between -9° and -15° ; reduced to 1850. Published as *Supplementband No. 12* to the *Annalen der Münchener Sternwarte*. 8vo. München, 1872.]
1872. STONE, E. J., *Mean Places of 78 Stars near the S. Pole, observed at the Cape of Good Hope*. [Reduced to 1871.0.] *Month. Not.*, vol. xxxiii. p. 55. Nov. 1872.
1873. YARNALL, M., *Catalogue of Stars observed at the United States Naval Observatory, Washington*. [Contains 10,658 stars; reduced to 1860. Published as Appendix III. to the *Washington Observations*, 1871.]
1873. MACLEAR, Sir T., *Cape Catalogue of 1159 Stars*. 8vo. Cape Town. [Stars observed at the Cape of Good Hope, 1856-61; reduced to 1860. Edited by Stone.]
1874. ELLERY, R. J., *First Melbourne General Catalogue* [of 1227 stars observed at Melbourne; reduced to 1870.0.] 4to. Melbourne.
1874. LAMONT, J., *Verzeichniss von telescopischen Sternen*. [Contains 5563 stars North of $+15^{\circ}$ and South of -15° ; reduced to 1850. Published as *Supplementband No. 13* to the *Annalen der Münchener Sternwarte*. 8vo. München. This volume also contains, as supplements to previous catalogues, the places of 3466 stars.]
1875. STONE, E. J., *Proper Motions of 406 Southern Stars*. *Memoirs R.A.S.*, vol. xlii. p. 129. 1875.

1875. WINLOCK, J., *Right Ascensions of Fundamental Stars observed at Harvard College Observatory, 1872-3*. *Ast. Nach.*, vol. lxxxvii. Nos. 206-90, Dec. 29. 1875. [Contains 355 stars; reduced to 1873.0.]
1877. *An observing list of Stars selected for the determination of Time with the Portable Meridian Transit in the Southern Hemisphere*. 8vo. Hydrographic Office, Washington, U.S. [Contains 408 stars. Epoch 1878.]
1877. BIRMINGHAM, J., *The Red Stars; Observations and Catalogue*. *Trans. Royal Irish Acad.*, vol. xxvi. [Contains 723 stars and copious notes.]
1877. SAFFORD, T. H. *Annals of Harvard College Observatory*, vol. x. [Contains several catalogues of stars observed at Harvard College.]
1877. STRASSER, P. G., *Mittlere Örter von Fixsternen*. [Contains 750 stars observed at Kremsmünster, reduced to 1870.]
1878. AIRY, G. B., "*Nine-Year Catalogue*." Published in App. to *Greenwich Obs.*, 1876. [Contains 2263 stars observed at Greenwich. Reduced to 1872.0.]
1878. MACLEAR, Sir T., *Cape Catalogue of Stars for 1840*. [Contains 2892 stars, observed 1834-40, but many of them however only in one element. Edited by Stone.]
1878. SAFFORD, T. H., *Right Ascensions of 505 Stars*. *Annals of Harvard College Observatory*, vol. iv. pt. ii. [Epoch 1865.0.]
1878. TAINTOR, E. C., *Catalogue of 384 Transit Stars*. Privately printed at Shanghai. [A compilation from the British, American, and French National Almanacs, which would have been very useful if the Precessions had been given.]
1881. NEWCOMB, S., *Catalogue of Standard Clock and Zodiacal Stars*. [Contains 1098 stars, various, reduced to 1850, &c.]
1881. STONE, E. J., *Catalogue of 12,441 Stars for the Epoch 1880, from Observations at the Cape, 1871-79*. 4to. London.
1882. DREYER, J. L. E., *Mean Places of 321 Red Stars chiefly from Schjellerup's Catalogue*. [Published in *Dunsink Observations*, part iv. Epoch 1875.0.]
1883. AUWERS, A., *Mittlere Örter von 83 südlichen Sternen*. *Astronomische Gesellschaft Publicationen*, no. xvii. 4to. Leipzig. [Epoch 1875.0.]
1883. GRANT, R., *Catalogue of 6415 Stars, Epoch 1870, from Observations made at Glasgow, 1860-81*. 4to. Glasgow.
1883. KRÜGER, A., *Zonenbeobachtungen der Sterne zwischen 55° und 65° nördlicher Declination, angestellt auf den Sternwarten zu Helsingfors und Gotha*. 4to. Helsingfors.
1884. BALL, R. S., *Observations in search of Stars with an annual Parallax*. [Published in *Dunsink Observations*, part v. Contains 409 stars.]
1884. PICKERING, E. C., *General Catalogue of the Magnitudes of 4260 Stars, with their approximate places for 1880*. *Annals of Harvard College Observatory*, vol. xiv. part i. p. 101. 1884. [The most complete and valuable record of Photometric Star magnitudes extant.]
1885. PRITCHARD, C., *Uranometria Nova Oxoniensis*. 8vo. Oxford.
1886. GOULD, B. A., *Catalogo general Argentino*. [Contains 32,448 stars; epoch 1875.0: also in the preface, the names of some catalogues not cited in this work.]
1886. ROGERS, W. A. *Harvard Catalogue of 1213 Stars*. *Annals of Harvard College Observatory*, vol. xv. [Epoch 1875.0.]
1886. STRUVE, O., *Positions moyennes de 3542 Étoiles*. [Published in *Pulkova Obs.*, vol. viii. Contains 3542 stars; epoch 1855.0.]

1887. AUWERS, A. *Catalogue of 480 Fundamental Stars.* *Month. Not. R.A.S.*, vol. xlvii. p. 455, June 1887. [Epoch 1900.]
1887. CHAMBERS, G. F., *A Working Catalogue of Red Stars.* *Month. Not. R.A.S.*, vol. xlvii. p. 348, April, 1887. [Epoch 1890.]
1887. LAMB, Miss Alice M., *Index to certain classes of Stars contained in the Greenwich Catalogues.* *Washburn Observatory Publications*, No. v. [Epoch 1875: contains 3145 stars not designated with a constellation name, with a number, or with a letter.]
1887. MOUCHEZ, E., *Catalogue de l'observatoire de Paris*, 0^h to VI^h. [Epochs various. Contains 7245 stars.]
1887. PICKERING, E. C., *Catalogue of Stars employed in various Nautical Almanacs.* *Annals of Harvard College Observatory*, vol. xviii. p. 1. [Epoch 1900. Deals especially with magnitudes.]
1887. POGSON, N. R., *Mean Positions of Stars observed at Madras.* [Epoch 1864. Contains 1000 stars chiefly in Southern hemisphere.]
1887. RAMBAUT, A. A., *Mean Places of 1012 Southern Stars.* [Published in *Dunsink Observations*, part vi. Epoch 1885.0.]
1888. CHANDLER, S. C., *Catalogue of Variable Stars.* *Astronomical Journal*, vol. viii. Sept. 6, 1888. [Contains 225 stars. Epoch 1855.]
1888. SAFFORD, T. H., *Williams College Catalogue of North Polar Stars.* [Epoch 1885. Contains 261 stars from the Radcliffe, Groombridge, and other catalogues.]

CATALOGUES OF DOUBLE STARS.

1782. HERSCHEL, W., 1st *Catalogue of Double Stars.* *Phil. Trans.*, vol. lxxii. p. 112. 1782. [Contains 269 stars.]
1785. HERSCHEL, W., 2nd *Catalogue of Double Stars.* *Phil. Trans.*, vol. lxxv. p. 40. 1785. [Contains 434 stars.]
1822. HERSCHEL, Sir W., 3rd Catalogue; *Places of 145 New Double Stars.* *Memoirs R.A.S.*, vol. i. p. 166. 1822.
1822. STRUVE, F. G. W., *Catalogus Stellarum Duplicium.* 4to. Dorpati. [Contains 795 stars observed at Dorpat; reduced to 1820.0.]
1822. SOUTH, J., *Observations of Double or Compound Stars.* *Memoirs R.A.S.*, vol. i. p. 109. 1822. [Contains 477 stars observed in London; reduced to 1821.0.]
1825. HERSCHEL, J. F. W., and SOUTH, J., *Observations of 380 Stars.* *Phil. Trans.*, vol. cxiv. part iii. p. 1. 1825.
1826. HERSCHEL, J. F. W., 1st Catalogue, *Approximate Places of 321 Stars.* *Memoirs R.A.S.*, vol. ii. p. 475. 1826.
1826. SOUTH, J., *Observations of 458 Double and Triple Stars*, [and a re-examination of 43 old double stars.] *Phil. Trans.*, vol. cxvi. p. 1. [And as a separate publication.]
1826. STRUVE, F. G. W., *Comparison of Observations on Double Stars.* [Being notes on 56 Herschel and South stars re-observed at Dorpat.] *Memoirs R.A.S.*, vol. ii. p. 443. 1826.
1827. STRUVE, F. G. W., *Catalogus Novus Stellarum Duplicium et Multiplicium.* Fol. Dorpati. [Contains 3112 stars observed at Dorpat; reduced to 1826.0.]
1829. DUNLOP, J., *Approximate Places of Double Stars.* *Memoirs R.A.S.*, vol. iii. p. 257. 1829. [Contains 253 stars observed at Paramatta, N. S. W.]

1829. HERSCHEL, J. F. W., 2nd Catalogue, *Approximate Places and Descriptions of 295 Stars*. *Memoirs R.A.S.*, vol. iii. p. 47. 1829.
1829. HERSCHEL, J. F. W., 3rd Catalogue of 384 Double and Multiple Stars. *Memoirs R.A.S.*, vol. iii. pp. 177 and 201. 1829.
1829. HERSCHEL, J. F. W., *Comparative Catalogue of 284 Double Stars*. *Memoirs R.A.S.*, vol. iii. p. 190. 1829. [Stars observed at Dorpat and Slough.]
1831. HERSCHEL, J. F. W., 4th Catalogue, *Mean Places of 1236 Double Stars*. *Memoirs R.A.S.*, vol. iv. p. 331. 1831.
1831. LABAUME, B., *Catalogue of 195 Double Stars*. *Memoirs R.A.S.*, vol. iv. p. 165. [Stars from Lalande's *Histoire Céleste*, reduced to 1800.0.]
1833. HERSCHEL, J. F. W., *Micrometrical Measures of 364 Double Stars*. *Memoirs R.A.S.*, vol. v. p. 13. 1833. [Contains a blank form for use of observers of double stars.]
1833. HERSCHEL, Sir J. F. W., 5th Catalogue of Double Stars. *Memoirs R.A.S.*, vol. vi. p. 1. 1833. [Contains 2007 stars, 1304 being new.]
1833. DAWES, W. R., *Observations of Double Stars*. *Memoirs R.A.S.*, vol. v. p. 139. 1833. [Contains important comparative observations of 9 binary stars.]
1835. DAWES, W. R., *Micrometrical Measurements of 121 Double Stars*. [Observed at Ormskirk.] *Memoirs R.A.S.*, vol. viii. p. 61. 1835.
1835. HERSCHEL, Sir J. F. W., *Micrometrical Measures of Double Stars*. *Memoirs R.A.S.*, vol. viii. p. 37. 1835. [Contains 377 stars.]
1836. HERSCHEL, Sir J. F. W., 6th Catalogue of Double Stars. *Memoirs R.A.S.*, vol. ix. p. 193. 1836. [Contains 286 stars, 105 being new.]
1837. STRUVE, F. G. W., *Stellarum Duplicium et Multiplicium Mensuræ Micrometricæ, per magni Fraunhoferi tubum, &c.* Fol. Petropoli. [Contains 3112 stars observed at Dorpat.]
1843. STRUVE, F. G. W., *Catalogue de 514 étoiles doubles et multiples découvertes à Poulkova et Catalogue de 256 étoiles doubles principales*. Fol. St. Pétersbourg.]
1847. MÄDLER, J. H., *Untersuchungen über die Fixstern-systeme*, 2 vols. Fol. Leipzig, 1847. [Contains a very large collection of double star measures from various sources brought together to show movement or the contrary.]
1847. HERSCHEL, Sir J. F. W., 7th Catalogue, *Reduced Observations*. *Res. of Ast. Obs.*, p. 165. 4to. Lond. [Contains 2102 southern stars.]
- *1849. MÄDLER, J. H., *Tabulæ Generales Stellarum Duplicium*. [Contains about 600 of Struve's stars, combined for solar motion.]
1849. JACOB, W. S., *Catalogue of Double Stars*. *Memoirs R.A.S.*, vol. xvii. p. 179. 1849. [Contains 244 stars observed at Poona, 1845-8, and embraces a small Catalogue previously published in *Memoirs R.A.S.*, vol. xvi.]
1850. STRUVE, O., *Catalogue revu et corrigé des étoiles doubles et multiples découvertes à Poulkova*. *Mémoires de l'Académie de St. Pétersbourg*, 6th ser., vol. v. [Contains 514 stars; reduced to 1850, and is a 2nd edition of the Catalogue which appeared in 1843 in W. Struve's name.]
1851. DAWES, W. R., *Micrometrical Measurements of 221 Double Stars*. [Made at Ormskirk.] *Memoirs R.A.S.*, vol. xix. p. 191. 1851.
1852. STRUVE, F. G. W., *Stellarum Fixarum Positiones Mediæ*. Fol. Petropoli. [Contains 2874 stars observed at Dorpat; reduced to 1830.]
1854. FLETCHER, I., *Results of Micrometrical Measures*. *Memoirs R.A.S.*, vol. xxii. p. 167. 1854. [Contains 51 stars.]

1856. DEMBOWSKI, Baron H., *Ast. Nach.*, vols. xlii-iv, Nos. 999-1036, various numbers during 1856. [Contains 127 stars observed at Naples.]
1856. MÄDLER, J. H. [Contains numerous stars, from Struve, observed 1846-51. Published in Dorpat *Beobachtungen*, vol. xiii. A second series will be found in vol. xv. part I.]
1857. POWELL, E. B., *Observations of Double Stars.* *Memoirs R.A.S.*, vol. xxv. p. 55. 1857. [Contains 108 stars observed at Madras.]
- 1857-9. CLARK, A., *New Double Stars.* *Month. Not.*, vol. xvii. p. 257, July 1857; vol. xx. p. 55, Dec. 1859. [Contains 20 new double stars discovered by A. C., with copious notes by Dawes.]
1859. SECCHI, A., *Misure di Stelle doppie.* [Contains 1321 stars (whereof 1114 are from Struve), observed for movement. Published in *Memorie dell' Osservatorio del Collegio Romano*, No. v.]
1859. STRUVE, O., *Some lately discovered Double Stars.* *Month. Not.*, vol. xx. p. 8. Nov. 1859. [Contains 9 new double stars discovered by O. S., with copious notes.]
1860. JACOB, Capt. W. S., *Micrometrical Measures of 120 Double or Multiple Stars.* *Memoirs R.A.S.*, vol. xxviii. p. 13. 1860. [Observed at Madras, 1856-8.]
1861. WROTTESELEY, Lord, *A Catalogue of the Positions and Distances of 398 Double Stars.* *Memoirs R.A.S.*, vol. xxix. p. 85. 1861. [Places reduced to 1860.0.]
1864. DEMBOWSKI, Baron H., *Beobachtungen von Doppelsternen.* *Ast. Nach.*, vol. lxii. Nos. 1473-5. May 28, 1864. [Contains 171 stars observed at Gallarate.]
1864. POWELL, E. B., *Second Series of Observations.* *Memoirs R.A.S.*, vol. xxxii. p. 75. 1864. [Contains 56 double stars observed at Madras.]
1864. DAWES, W. R., *A List of New Double Stars.* *Month. Not.*, vol. xxiv. p. 117. March 1864. [Contains 15 new double stars discovered by W. R. D., with copious notes.]
- *1865. ENGELMANN, R., *Messungen von 90 Doppelsternen.* [Observed at Leipzig.]
1865. ROMBERG, H., *Double Stars taken from Struve's Catalogue.* [Contains measurements of 65 stars made at Mr. J. G. Barclay's Observatory, Leyton, 1862-4; reduced to 1865.0. Published in *Leyton Astronomical Obs.*, vol. i. p. 1. 4to. Lond., 1865.]
1867. DAWES, W. R., *Catalogue.* *Memoirs R.A.S.*, vol. xxxv. p. 137. 1867. [Contains 2135 stars observed at various places; reduced to 1850.]
1867. HERSCHEL, Sir J. F. W., *Synopsis of all Sir W. Herschel's Doubles.* [812 in number; reduced to 1880.] *Memoirs R.A.S.*, vol. xxxv. p. 21. [See corrections by Sir J. H. in *Month. Not.*, vol. xxviii. p. 151, March 1868; and by Burnham, *Month. Not.*, vol. xxxiv. p. 98, Jan. 1874.]
1868. ENGELMANN, R., *Doppelsternmessungen.* *Ast. Nach.*, vol. lxx. Nos. 1673-6. Jan. 17, 1868. [Contains 153 stars (chiefly Struve's) observed at Leipzig.]
1868. HERSCHEL, Sir J. F. W., *Additional Identifications of Double Stars... with a List of Errata.* *Month. Not.*, vol. xxviii. p. 151. March 1868. [Contains a long series of corrigenda for Sir J. H.'s edition of Sir W. H.'s Catalogue in *Memoirs R.A.S.*, vol. xxxv. p. 21. 1867.]
1869. DEMBOWSKI, Baron H., *Ast. Nach.*, vol. lxxiii. Nos. 1735-6. Jan. 22, 1869. [Contains 163 stars observed at Gallarate.]
1870. TALMAGE, C. G., *Double-Star Observations.* [Contains measurements of 218 stars made at Mr. J. G. Barclay's Observatory, Leyton, 1865-9; reduced to

- 1870-0. Published in *Leyton Astronomical Obs.*, vol. ii. p. 1. 4to. Lond., 1870.]
1873. BURNHAM, S. W., *Catalogues. Month. Not.*, vol. xxxiii. pp. 351 and 437. March and May 1873. [Contain 81 and 25 new Doubles discovered at Chicago, U.S.; reduced to 1870.]
1873. BURNHAM, S. W., *Third Catalogue. Month. Not.*, vol. xxxiv. p. 59. Dec. 1873. [Contains 76 new Doubles discovered at Chicago, U.S.; reduced to 1880.]
1873. TALMAGE, C. G., *Double-Star Observations*. [Contains measurements of 91 stars made at Mr. J. G. Barclay's Observatory, Leyton, 1870-2; reduced to 1870-0. Published in *Leyton Astronomical Obs.*, vol. iii. part i. p. 1. 4to. Lond., 1873.]
1874. DEMBOWSKI, Baron H., *Ast. Nach.*, vol. lxxxiii. No. 1979. March 18, 1874. [Contains 34 stars observed at Gallarate.]
1874. BURNHAM, S. W., *Fourth Catalogue. Month. Not.*, vol. xxxiv. p. 382. June 1875. [Contains 47 new Doubles discovered at Chicago, U.S.; reduced to 1880.]
1874. BURNHAM, S. W., *Fifth Catalogue. Month. Not.*, vol. xxxv. p. 31. Nov. 1874. [Contains 71 new Doubles discovered at various American Observatories; reduced to 1880.]
1875. HERSCHEL, Sir J. F. W., *Catalogue of 10,300 Multiple and Double Stars. Memoirs R.A.S.*, vol. xl. p. 1. 1875. [From various sources; reduced to 1830. Edited by Main and Pritchard. A most useless work.]
1875. WILSON, J. M., and G. M. SEABROKE, *Catalogue of Micrometrical Measurements of Double Stars. Memoirs R.A.S.*, vol. xlii. p. 59. 1875. [Contains 467 stars observed at Rugby.]
1875. GLEDHILL, J., *Measures of 484 Double Stars made at Halifax. Memoirs R.A.S.*, vol. xlii. p. 101. 1875.
1875. BURNHAM, S. W., *Sixth Catalogue. Ast. Nach.*, vol. lxxxvi. No. 2062. Nov. 5, 1875. [Contains 90 new Doubles discovered at Chicago, U.S.; reduced to 1880.]
1876. BURNHAM, S. W., *A Catalogue of Red Double Stars. Month. Not.*, vol. xxxvi. p. 331. May 1876. [Contains 102 stars within 121° of N.P.D., which are not in Schjellerup's *Catalogue*, 2nd ed.]
1876. BURNHAM, S. W., *Seventh Catalogue. Ast. Nach.*, vol. lxxxviii. No. 2103. Aug. 31, 1876. [Contains 46 new Doubles discovered at Chicago, U.S.; reduced to 1880.]
1876. DUNER, N. C., *Mesures micrométriques d'étoiles doubles*. [Contains 442 Struve stars observed at Lund, reduced to 1870.]
1876. HOWE, H. A., *Catalogue of 50 new Double Stars discovered with the 11-inch refractor of the Cincinnati Observatory. Publications of the Cincinnati Observatory*. [Epoch 1880-0.]
1876. MITCHELL, O. M., *Micrometrical Observations of Double Stars*. Edited by O. Stone. *Publications of the Cincinnati Observatory*. [Epoch 1880-0.]
1877. MITCHELL, O. M., *Observations of Double Stars. Month. Not. R.A.S.*, vol. xxxvii. p. 122. Jan. 1877. [Contains 65 Doubles, various, observed at Cincinnati, U.S., 1845-8. Edited by C. Abbe.]
1877. STONE, O., *Micrometrical Measurements of Double Stars. Publications of the Cincinnati Observatory*. [371 stars, chiefly -15° to -35° . Epoch 1880-0.]

1879. BURNHAM, S. W., *Catalogue of 251 new Double Stars: Micrometrical Measures of 500 Double Stars.* *Memoirs R.A.S.*, vol. xlv. p. 141.
- 1880-87. JEDRZEJEWICZ, *Mesures micrométriques d'étoiles doubles.* *Ast. Nach.*, vol. xcvii. No. 2324, July 18, 1880; vol. xcvi. Nos. 2329, 2340-41, 2343, 2346-47, 2351; vol. xcix. No. 2369; vol. ciii. Nos. 2449-50; vol. cxvi. No. 2772, Feb. 16, 1887.
1881. HALL, A., *Observations of Double Stars, made at the U. S. Naval Observatory, Washington.* [Contains 422 stars, chiefly Struve's, reduced to 1880.]
1881. SEABROKE, G. M., *Third Catalogue of Micrometrical Measures of Double Stars made at the Temple Observatory, Rugby.* *Memoirs R.A.S.*, vol. xlvi. p. 183. [Contains 224 stars, general, reduced to 1880.]
1882. PICKERING, E. C., *Micrometric Measurements of Double Stars.* *Annals of Harvard College Observatory*, vol. xiii. p. 17. [Contains observations of 179 new and 344 old Doubles made at Washington by various observers, 1866-72, chiefly under the superintendence of J. Winlock.]
1883. BURNHAM, S. W., *Catalogue of 151 Double Stars: Micrometrical Measures of 770 Double Stars.* *Memoirs R.A.S.*, vol. xlvii. p. 167.
1883. DEMBOWSKI, Baron H. von, *Misure micrometriche di stelle doppie e multiple fatte negli anni 1852-78.* 2 vols. 4to. Roma, 1883-4.
1883. RUSSELL, H. C., *Measures of Sir John Herschel's Cape Stars, together with a list of new Double Stars.* *Memoirs R.A.S.*, vol. xlvii. p. 109. [Contains 738 Herschelian stars and 343 new ones.]
1885. ENGELMANN, W., *Doppelsternmessungen.* *Ast. Nach.*, vol. cxi. Nos. 2652-3, May 20, 1885; vol. cxii. Nos. 2677-8, Sept. 5, 1885. [These papers contain a very large number of recent measures of Σ , $O\Sigma$, and β stars.]
1887. VON ENGELHARDT, *Mikrometrische Messungen.* *Ast. Nach.*, vol. cxvii. No. 2785. May 9, 1887. [Contains 18 wide Σ stars.]
1887. ENGELMANN, R., *Doppelsternmessungen.* *Ast. Nach.*, vol. cxvii. No. 2786. May 18, 1887. [Contains 62 Σ , $O\Sigma$, and β stars.]
1887. HOUGH, G. W., *Catalogue of 209 new Double Stars.* *Ast. Nach.*, vol. cxvi. Nos. 2778-9. Also in *Annual Report of Chicago Astronomical Soc.* 1887, p. 27. [Contains 209 stars, chiefly close pairs of small mag. Reduced to 1880.]
1887. PERROTIN, J., *Mesures micrométriques d'étoiles doubles.* *Annales de l'Observatoire de Nice*, vol. ii. [Contains observations of a very large number of Struve's stars made in 1883-6.]
1888. SCHIAPARELLI, G. V., *Misure di stelle doppie.* *Publicazioni del Reale Osservatorio di Brera in Milano.* No. XXXIII. [Contains 465 Σ stars observed at Milan 1875-85.]
1888. TARRANT, K. J., *Double Stars.* *Ast. Nach.*, vol. cxx. No. 2866. Nov. 10, 1888. [Contains 77 Σ and β stars of large magnitude.]
1889. BURNHAM, S. W., *Double Stars.* *Ast. Nach.*, vol. cxx. No. 2875. Jan. 24, 1889. [Contains 45 new and Σ Stars.]
1889. BURNHAM, S. W., *Double Stars.* *Ast. Nach.*, vol. cxxiii. Nos. 2929-30. Oct. 21, 1889. [Contains 54 new doubles discovered at the Lick Observatory, together with measures of a few other stars.]

CATALOGUES OF NEBULÆ (INCLUDING CLUSTERS.)^a

1716. HALLEY, E., *An Account of several Nebulæ or Lucid Spots.* *Phil. Trans.*, vol. xxix. p. 390. [Contains an account of 6 nebulae.]
1735. DERHAM, Rev. W., *Observations of the Appearances among the Fixed Stars, called Nebulous Stars.* *Phil. Trans.*, xxxviii. p. 70. [Contains 16 nebulae.]
- *1761. LA CAILLE, *Sur les Étoiles Nébuleuses du Ciel Austral.* [Contains 42 nebulae observed at the Cape of Good Hope.] *Mém. Acad. des Sciences*, 1755, p. 149.
- *1784. MESSIER, *Catalogue des Nébuleuses et des Amas d'Étoiles.* [Contains 103 nebulae.] Published in the *Connaissance des Temps*, 1784, pp. 227, 268.
1786. HERSCHEL, W., *Catalogue of 1000 new Nebulæ.* [Observed at Slough.] *Phil. Trans.*, vol. lxxvi. p. 457. 1786.
1789. HERSCHEL, W., *Catalogue of a second 1000 of new Nebulæ.* [Observed at Slough.] *Phil. Trans.*, vol. lxxix. p. 212. 1789.
1802. HERSCHEL, W., *Catalogue of 500 new Nebulæ.* [Observed at Slough.] *Phil. Trans.*, vol. xcii. p. 477. 1792.
1828. DUNLOP, J., *Catalogue of Nebulæ.* *Phil. Trans.*, vol. cxviii. p. 113. 1828. [Contains 629 nebulae observed [?] at Paramatta, N.S.W. Engravings of 27.]
1833. HERSCHEL, Sir J. F. W., *Observations of Nebulæ and Clusters.* *Phil. Trans.*, vol. cxxiii. p. 359. 1833. [Contains 2307 nebulae observed at Slough, whereof about 500 were new; reduced to 1830-0. Engravings of 67.]
1837. LAMONT, J., *Ueber die Nebelflecken.* 4to. München. [Remarks on nebulae generally, with notes on and rough lithographic sketches of 11 nebulae in particular.]
1841. SMITH, H. L., and MASON, E. P., *Observations on Nebulæ with a 14-ft. Reflector.* *Trans. Amer. Phil. Soc.*, 2nd series, vol. vii. pp. 165-213. 1841. [Contains observations and detailed notes on 4 nebulae, with figures thereof, black on white ground. The nebulae are h 1991, 2008, 2092, and 2093.]
1844. ROSSE, Earl of, *Observations on some of the Nebulæ.* *Phil. Trans.*, vol. cxxxiv. p. 321. 1844. [Engravings (5), and notes on nebulae observed at Birr Castle.]
1847. HERSCHEL, Sir J. F. W., *Observations of Nebulæ.* [Contains 1708 nebulae observed at the Cape of Good Hope; reduced to 1830. Engravings of 60. Published in *Results of Astronomical Observations, &c.*, p. 1. 4to. Lond., 1847.]
1847. HERSCHEL, Sir W., *Places and Descriptions of 8 Nebulæ.* [Published in his son's *Results of Astronomical Observations*, p. 128.]
1850. ROSSE, Earl of, *Observations on the Nebulæ.* *Phil. Trans.*, vol. cxl. p. 499. 1850. [Engravings (17), and notes on nebulae observed at Birr Castle.]
1853. LAUGIER, E., *Nouveau Catalogue de Nébuleuses.* *Compt. Rend.*, vol. xxxvii. p. 874. Dec. 12, 1853. [Contains 53 nebulae observed at Paris; reduced to 1850-0. Nebulae were selected which had defined centres, so as to secure good observations of places such as might hereafter become available for investigations as to proper motion.]
1856. D'ARREST, *Resultate aus Beobachtungen der Nebelflecken.* *Abhandlung der Königl. Sächs. Gesellschaft der Wissenschaften.* [Contains about 230 nebulae observed at Leipzig; reduced to 1850-0.]

^a References to the many small catalogues published at various times and in various places by STÉPHAN, SWIFT, and

TEMPEL have been excluded from this List because they have all been embodied in Dreyer's *General Catalogue* of 1888.

1862. AUWERS, A., *Verzeichniss von Nebelflecken und Sternhaufen*. Fol. Königsberg. [Contains about 2600 nebulae (some duplicate), chiefly from Sir W. Herschel's Catalogues; reduced to 1830. In this work is reprinted Messier's old but important catalogue of 101 nebulae.]
1862. ROSSE, Earl of, *Selected Observations of Nebulae*. *Phil. Trans.* vol. cli. p. 709. 1862. [Contains notes on 989 nebulae observed at Birr Castle. Engravings of 43.]
1862. AUWERS, A., *Verzeichniss der Oerter von vierzig Nebelflecken*. *Ast. Nach.*, vol. lviii. No. 1392. Nov. 14, 1862. [Contains 40 Herscheliana nebulae observed at Königsberg.]
1863. BOND, G. P., *List of new Nebulae*. *Ast. Nach.*, vol. lxi. No. 1453. Dec. 18, 1863. [Contains 33 unrecorded nebulae discovered at various times at Harvard College Observatory.]
1864. HERSCHEL, Sir J. F. W., *Catalogue of Nebulae and Clusters of Stars*. *Phil. Trans.*, vol. cliv. p. 1. 1864. [Contains 5079 objects (all then known). A grand work in every sense.]
1865. AUWERS, A., *Beobachtungen von Nebelflecken*. [Contains places for 1860.0 of 40 nebulae, chiefly Herscheliana. Published in vol. xxxv. of the *Astronomische Beobachtungen* of the Königsberg Observatory. Fol. Königsberg, 1865.]
1867. VOGEL, H. C., *Beobachtungen von Nebelflecken und Sternhaufen*. 8vo. Leipzig, 1867. [Contains 100 Herscheliana nebulae re-observed at Leipzig.]
1867. MARTH, A., *Catalogue of new Nebulae*. *Memoirs R.A.S.*, vol. xxxvi. p. 53. 1867. [Contains 600 nebulae, nearly all discovered with Mr. Lassell's telescope at Malta.]
1867. LASSELL, W., *Observations of Remarkable Nebulae*. *Memoirs R.A.S.*, vol. xxxvi. p. 39. 1867. [Contains notes on 37 nebulae observed at Malta, with engravings of all.]
1867. D'ARREST, H. L., *Siderum Nebulosorum Observationes Havnienses*. 4to. Havniæ. [Contains 1942 nebulae, whereof 390 are new; reduced to 1861.]
1868. SCHMIDT, J. F. J., *Mittlere Oerter von Nebeln*. *Ast. Nach.*, vol. lxx. No. 1678. Feb. 12, 1868. [Contains 110 nebulae observed for places.]
1872. D'ARREST, H., *Undersogelser over de nebulose Stjerner*. Published at Copenhagen. [Contains spectroscopic observations of a large number of Herscheliana nebulae.]
1875. SCHULTZ, H., *Month. Not.*, vol. xxxv. p. 135. Jan. 1875. [Contains 512 nebulae from various sources observed at Upsala; reduced to 1865-0. Important descriptive notes of the Herscheliana type are given. There is a 4to. edition, entitled *Micrometrical Observations of 500 Nebulae*, Upsala, 1874, in English throughout. This latter is reprinted from *Nova Acta Regiæ Societatis Scientiarum Upsaliensis*, 3rd series, vol. ix.]
1875. SCHÖNFELD, E., *Micrometrische Ortsbestimmungen von Nebelflecken und Sternhaufen*. [Contains valuable original observations of more than 600 Herscheliana and other nebulae; reduced to 1865-0. Published in vols. i-ii. of the *Astronomische Beobachtungen* of the Mannheim Observatory. 4to. Mannheim, 1862, and Carlsruhe, 1875.]
1878. DREYER, J. L. E., *A Supplement to Sir J. Herschel's 'General Catalogue.'* *Trans. Roy. Irish Acad.*, vol. xxvi. p. 381. [Contains 1171 nebulae, being all those discovered up to date by various observers: and numerous annotations and corrections applicable to Sir J. Herschel's volume.]

1882. PICKERING, E. C., *Catalogue of Nebulæ. Annals of Harvard Coll. Obs.*, vol. xiii. p. 66. [Contains observations and notes on 402 nebulæ, chiefly Herschelian, but a few of them new.]
1886. VON ENGELHARDT, B., *Observations de Nébuleuses et d'Amas Stellaires*. Published in his *Observations astronomiques*, pp. 124-85. [Contains 100 objects, chiefly Herschelian. Epoch 1865-0.]
1887. SAFFORD, T. H., *Nebulæ found at the Dearborn Observatory, 1866-8*. Published in *Annual Report of the Chicago Astronomical Society, 1887*, p. 37. [Contains 108 nebulæ: reduced to 1870.]
1888. DREYER, J. W. E., *New General Catalogue of Nebulæ and Clusters. Mem. R.A.S.*, vol. xlix. [Contains 7840 nebulæ, being Sir J. Herschel's *General Catalogue of 1864* revised, corrected, and enlarged. Epoch 1860, with precessions for 1880. The Preface supplies a sort of index to all the published observations of nebulæ of whatever kind.]

ATLASES, CHARTS, ETC.

1603. BAYER, J., *Vranometria, omnium Asterismorum continens schemata novâ Methodo delineata*. Fol. Ulmæ. [The earliest important maps of the stars; 51 plates in all.]
1627. SCHILLER, J., and others, *Cælvm Stellatvm Christianvm*. Oblong fol. Avgvstæ Vindelicorum. [A curious and very rare old work, depicting numerous saints enshrined amongst the stars. This is rather a revision of Bayer than an independent work.]
1690. HEVELIUS, J., *Firmamentum Sobieskianum, sive Uranographia*. Fol. Gedani. [Contains 54 plates and 2 hemispheres. Some new constellations are introduced.]
1729. FLAMSTEED, Rev. J., *Atlas Cælestis*. Fol. Londini. [Contains 27 maps. Last edition, 1781. Universally used during the last century.]
1742. DOPPELMAIER, J. G., *Atlas Cælestis*. Fol. Norimbergæ. [Contains 34 maps and plates.]
1776. FLAMSTEED, Rev. J., *Atlas Celestis*. Edited for the *Academie des Sciences* at Paris, by J. Fortin. 2nd ed. Paris. [Contains 30 maps and charts.]
1782. FLAMSTEED, Rev. J., *Représentation des Astres...suivant l'Atlas Céleste de Flamsteed...corrigée, par J. E. Bode*. Oblong 4to. Berlin, 1782. [Contains 34 maps and charts.]
1801. BODE, J. E., *Uranographia, sive astrorum descriptio 20 tabulis æneis incisa*. Fol. Berolini. [Exhibits 17,240 stars; epoch 1801.]
1811. WOLLASTON, F., *A Portraiture of the Heavens as they appear to the Naked Eye*. Fol. Lond., 1811. [Contains 10 plates; stars, black on white ground.]
1822. JAMIESON, A., *A Celestial Atlas, comprising a systematic display of the Heavens in 30 Maps*. Oblong 4to. [Contains a large amount of information and no little nonsense.]
1822. HARDING, C. L., *Atlas Novus Cælestis continens stellas inter polum borealem et 30mum grad. declinationis Australis adhuc observatas*. Gottingæ. [Contains above 40,000 stars down to mag. 9, and is executed with evident care. Last edition, Halle, 1856.]
1824. GREEN, J., *Astronomical Recreations, or Sketches of the Relative Positions*

and Mythological History of the Constellations. 4to. Philadelphia. [Contains 19 plates, whereof 17 give the constellations reduced from Bode's Atlas, coloured by hand, and with stars to mag. 4. The historical and uranographical notes are very full.]

1824. LOHRMANN, W. G., *Karte des Mondes.* Leipzig. Published by J. A. Barth. [A well-executed copper-plate engraving about 3 ft. in diameter. There is also a small engraving by the same author about 15 inches in diameter.]
- 1830-59. BERLIN ACADEMY, *Akademische Sternkarten.* Fol. Berlin. [24 equatorial charts—one for each hour of R.A.— 30° in extent in Declination, by various observers. Contains all stars down to mag. 9, and some smaller ones. Catalogues in a tabular form of the registered stars are appended. The charts are of high value.]
1836. SOCIETY FOR DIFFUSION OF USEFUL KNOWLEDGE, *Six Maps of the Stars on the gnomonic projection, edited by Sir J. W. Lubbock, Bt.* [Epoch 1840. Two editions, large folio and imperial 4to. London. An important and well-executed work, but the value of the maps is impaired by the great distortion of the corners of each. Of the smaller maps a new edition, edited by C. O. Dayman, has appeared.]
1837. BEER, W. and MÄDLER, J. H. *Mappa Selenographica.* [A well-known and valuable map of the Moon.]
1841. DIEN, C., *Atlas du Zodiaque.* Large 4to. Paris. [Contains 15 charts on white ground. Full of errors.]
1842. MIDDLETON, J., *Celestial Atlas.* Oblong fol. Norwich. [Contains maps of the stars in duplicate, one set being a facsimile of the heavens, stars white on black ground; the other, maps ordinary, with constellations and stars engraved in the usual manner and coloured.]
1843. SCHWINCK, G., *Mappa Cælestis.* Lipsiæ. [Map, on 5 sheets, of stars visible in Central Europe.]
1843. ARGELANDER, F. G. A., *Uranometria Nova.* Oblong demy fol. Berlin. [Contains 17 maps on white ground; boundaries faintly tinted. All stars visible to the naked eye in Europe are inserted, the magnitude being given with great care and precision from original observations. Altogether a highly valuable work.]
1850. BISHOP, G., Ecliptic charts for every hour of R. A. [Never completed. Constructed by Hind and others, and published at G. Bishop's expense. Epoch 1825.]
1854. LITTRON, J. J. Von, *Atlas des Gestirnten Himmels.* 2nd ed., by C. Von Littrow. 8vo. Stuttgart.
1855. HIND, J. R., *Atlas of Astronomy.* [Contains 18 plates with brief explanations. There are 6 maps of the stars, white on blue ground, of great usefulness for identifying particular stars. A new edition, with additional plates, has appeared.]
- 1857-61. BONN OBSERVATORY, *Atlas des nördlichen gestirnten Himmels.* [For the epoch of 1855.0. Contains 40 charts on white ground of stars down to mag. $9\frac{1}{2}$: without names or boundaries. An extension of this from 0° to 23° South, by Schonfeld, appeared in 1887.]
1862. CHACORNAC, *Atlas Écliptique.* [Intended to have comprised 72 charts on white ground, but never completed. No names or boundaries. Stars from mags. 7-13.]

1865. DIEN, CH., *Atlas Céleste*. [Contains 24 charts on white ground, for the epoch of 1860. Many thousands of stars are given.]
1866. LITTRON, C. VON, *Atlas des Gestirnten Himmels*. 3rd ed. Stuttgart.
- ✓ 1867. PROCTOR, R. A., *The Constellation Seasons*. 4to. Lond. [12 charts for different months of the year.]
- ✓ 1870. PROCTOR, R. A., *A new Star Atlas*. Small fol. London.
- *1872. BRUHNS, C., *Atlas der Astronomie*.
1872. HEIS, E., *Neuer Himmels Atlas*. Oblong fol. Köln. [Maps for Europe only; with a catalogue of stars in a separate 8vo. volume.]
1874. BEHRMANN, C., *Atlas des südlichen gestirnten Himmels*. Oblong fol. Leipzig. [Maps for the Southern hemisphere only; with a catalogue of stars in a separate 8vo. volume.]
1878. HEIS, Dr. E., *Atlas Cælestis Eclipticus, octo continens tabulas ad delineandum Lumen Zodiacale*. Oblong fol. Coloniae, 1878.
1878. HOUZEAU, J. C., *Atlas de toutes les étoiles visibles à l'œil nu*. Fcp. fol. Mons. [An original popular work, not very distinct to the eye.]
1878. LOHRMANN, W. G., *Mondcharte in 25 Sectionen*. Large 4to. Leipzig. [A new edition by J. F. J. Schmidt of an old work of which only the 1st part was published in 1824.]
1878. SCHMIDT, J. F. J., *Charte der Gebirge des Mondes*. Berlin. [In 25 large plates, accompanied by a descriptive volume.]
1882. PETERS, C. H. F., *Celestial Charts*. Oblong fol. [Contains 20 charts of the Zodiacal Heavens, with stars from mag. 6 to 11. From observations made at Hamilton College, Clinton, U.S. Epoch 1860.]
1886. SCHURIG, R., *Himmels-Atlas*. Fcp. fol. Leipzig. [A cheap and popular work, well drawn and lithographed, and with the various objects well distinguished. Epoch 1885.]
1888. KLEIN, H. J., *Star Atlas*. 4to. London, S.P.C.K. [Translated and adapted for English Readers by E. McClure. Has a useful catalogue of popular celestial objects prefixed.]
1888. MESSER, J., *Stern-Atlas für Himmelsbeobachtungen*. Narrow 8vo. St. Petersburg. [27 maps, black on white, with descriptions of the chief objects in each constellation.]

MISCELLANEOUS CATALOGUES.

1844. SMYTH, Admiral W. H., *Cycle of Celestial Objects*, 2 vols. 8vo. Lond. [Contains 580 double stars, 20 binary systems, 80 triple and multiple stars, and 170 clusters and nebulae, observed at Bedford; reduced to Jan. 1, 1840. A most interesting but very scarce work.]
- ✓ 1859. WEBB, Rev. T. W., *Celestial Objects for Common Telescopes*. 18mo. Lond.
1880. KLEIN, H. J., *Astronomische Objecte für gewöhnliche Telescopien*. 8vo. Brunswick.
1881. SMYTH, Admiral W. H., and CHAMBERS, G. F., *A Cycle of Celestial Objects*. 8vo. Lond. [Contains 1604 objects, being the "Bedford Catalogue" of 1844 largely extended and modernised.]

CATALOGUES OF COMETS.

1783. PINGRÉ, A., *Cométographie*. 4to. Paris. [A most elaborate history of all recorded comets.]

1847. GALLE, J. G. [Published in Encke's edition of Olbers's *Abhandlung über die leichteste und bequemste Methode die Bahn eines Cometen zu berechnen*. 8vo. Weimar, 1847. Contains orbits of 178 comets. Galle published a supplement to this in 1864, appended to his new edition of the *Abhandlung*, and a further supplement in *Ast. Nach.*, vol. cxii. Nos. 2665-6, June 5, 1885.]
1847. JAHN, G. A., *Verzeichniss aller bis zum Jahre 1847 berechneten Kometenbahnen*. Oblong 4to. Leipzig, 1847. [Contains orbits of 195 comets.]
1852. COOPER, E. J., *Cometic Orbits*. 8vo. Dublin. [Contains 198 comets, with copious notes appended thereto. No less than 754 distinct sets of elements are given.]
1852. HIND, J. R. [Contains 231 comets: appended to the author's *Descriptive Treatise on Comets*. 12mo. London.]
1864. CARL, P., *Repertorium der Cometen Astronomie*. 8vo. München, 1864. [A most valuable and complete cyclopædia of cometary observations and elements.]
1871. WILLIAMS, J., *Observations of Comets, from B.C. 611 to A.D. 1640*. 4to. Lond. [Contains 373 comets observed in China.]
1889. CHAMBERS, G. F., *Catalogues of Comets*. [Contains Tables of 394 calculated comets, and an historical abstract of observations of 539 other comets, being all on record up till June 1889. See *Handbook of Descriptive Astronomy*, 4th ed., vol. i. pp. 511-588, *ante*.]

CATALOGUES OF STARS BY SPECTRA.

1867. SECCHI, A., *Catalogo delle Stelle di cui si è determinato lo spettro luminoso &c.* Parigi.
1883. VOGEL, H. C., *Spektroskopische Beobachtungen der Sterne bis einschliesslich 7.5ter Grösse*. Potsdam.
1885. DUNÉR, N. C., *Sur les étoiles à spectres de la troisième Classe*. *Kongl. Svenska Vetenskaps-Akademiens Handlingar*. Vol. xxi. Part 2. [Contains detailed observations on 352 stars.]
- 188-? ESPIN, Rev. T. E., *Stars with remarkable spectra* [44 stars]. *Liverpool Astron. Soc. Observatory Publications*, No. 1.
1887. ESPIN, Rev. T. E., *Stars with remarkable spectra* [47 Stars]. *Ast. Nach.*, vol. cxvii., No. 2788, June 1, 1887.
1888. ESPIN, Rev. T. E., *Stars with remarkable spectra* [79 stars]. *Ast. Nach.*, vol. cxviii., No. 2825, Feb. 3, 1888.
1888. ESPIN, Rev. T. E., *Stars with remarkable spectra* [39 Stars]. *Ast. Nach.*, vol. cxix., No. 2852, Aug. 10, 1888.
1889. ESPIN, Rev. T. E., *Stars with remarkable spectra* [72 Stars]. *Ast. Nach.*, vol. cxxi., No. 2883, March 12, 1889.
1889. ESPIN, Rev. T. E., *Catalogue of Stars of Type IV*. *Month. Not.*, vol. xlix. p. 364, April, 1889. [Contains 113 stars for 1890, being all those known.]
1889. ESPIN, Rev. T. E., *Stars with remarkable spectra* [53 Stars]. *Ast. Nach.*, vol. cxxii., No. 2919, Aug. 29, 1889.

The stars in the above lists are all arranged in order of R.A.

1889. ELLERY, R. L. J., *Preliminary Spectroscopic Survey of Southern Stars*. *Month. Not.*, vol. xlix. p. 439. [Contains 100 stars.]

CHAPTER II.

LIST OF BOOKS RELATING TO, OR BEARING ON,
ASTRONOMY^a.

- ABBOTT, T. K., B.D., *Elementary Theory of the Tides*. London, 1888.
- ✓ AIRY, Sir G. B., *Popular Astronomy*. [Ipswich Lectures.] 12th ed., 16mo. London, 1887.
- ANDRÉ, C., and RAYET, G., *L'Astronomie pratique et les Observatoires en Europe et en Amérique*. Parts i. and ii. Great Britain and the British Colonies. 18mo. Paris, 1874.
- ✓ ARAGO, Francois, *Astronomie Populaire*. 4 vols. 8vo. Paris, 1854-8.
**Popular Astronomy*. Trans. W. H. Smyth and R. Grant. 2 vols. 8vo. London, 1855-8.
- ARATUS, *Phenomena and Dioceseia*. Translated into English Verse by the Rev. J. Lamb, D.D. 8vo. London, 1847.
- ARISTOTELES, *Opera*. Ed. Acad. Reg. Boruss. 4 vols. 4to. Berolini, 1831-6.
**Astronomical Register*. 8vo. London, v. y.
**Astronomische Nachrichten*. 4to. Altona, afterwards and still Kiel, v. y.
- BAILLY, J. S., *Histoire de l'Astronomie Ancienne*. 4to. Paris, 1781.
Histoire de l'Astronomie Moderne. 3 vols. 4to. Paris, 1785.
Traité de l'Astronomie Indienne et Orientale. 4to. Paris, 1787.
- BAILY, F., *Astronomical Tables and Formulæ*. 8vo. London, 1827-9.
- ✓ BALL, Sir R. S., LL.D., *The Story of the Heavens*. London, 1886.
Elements of Astronomy ("Text Books of Science"). London, 1880.
- BARLOW, Rev. J., *Astronomy Simplified for the Use of Schools and Families*. [Q. and A.] 24mo. London, n. d.
- BEER, W., and MÄDLER, J. H., *Der Mond*. 4to. Berlin, 1837.

^a It will be observed that I apply no adjective to this list. I do not call it 'complete,' or 'comprehensive,' or 'select,' or 'useful.' It is simply an enumeration of books which I have, as a matter of fact, consulted or looked at, or been advised by friends to include here. In the judgment of some persons it may include some worthless books, and may not include

some valuable ones. At any rate I shall be very willing to receive suggestions for alterations in it calculated to benefit science. In the case of new books I must be shown the books themselves. The asterisk (*) denotes books which amateur observers will find useful, and which therefore I must be taken as in some sense recommending.

- BESSEL, F. W., *Tabulæ Regiomontanæ, reductionum observationum Astronomicarum, 1750-1850 computatæ.* 8vo. Regiomonti, 1830.
- Fundamenta Astronomiæ pro anno 1775 deducta ex observationibus viri incomparabilis James Bradley in speculâ Astronomicâ Grenovicensi, &c.* Fol. Regiomonti, 1818.
- Abhandlungen.* Ed. by R. Engelmann. 3 vols. 4to. Leipzig, 1875-6.
- BIOT, J. B., *Traité Élémentaire de l'Astronomie Physique.* 3rd ed. 4 vols. Paris, 1844-7.
- Résumé de Chronologie Astronomique.* 4to. Paris, 1849. [From vol. xxii. of the *Mémoires de l'Académie des Sciences.*]
- BLAKE, J. F., *Astronomical Myths based on Flammarion's "History of the Heavens."* 8vo. London, 1877.
- *BOILLOT, A., *Traité Élémentaire d'Astronomie.* 18mo. Paris, 1866.
- BOUVIER, HANNAH M., *Familiar Astronomy.* 8vo. Philadelphia, 1856.
- BRADY, J., *Clavis Calendaria.* 2nd ed. 2 vols. 8vo. London, 1812.
- BRAHE, TYCHO, *Astronomiæ Instauratæ Progymnasmata.* 2 vols. 4to. Francofurti, 1610.
- BREEN, H., *Practical Astronomy.* 8vo. London, 1856. [In Orr's *Circle of the Sciences.*]
- BREWSTER, Sir D., *More Worlds than One.* 16mo. Edinburgh, 1854.
- Treatise on Optics.* 12mo. London, 1853.
- Memoirs of the Life, Writings, and Discoveries of Sir I. Newton.* 2 vols. 8vo. Edinburgh, 1855.
- Martyrs of Science.* New Edition, with Portraits. London, 1874.
- BRINKLEY, Bishop, *Astronomy.* Enlarged by Stubbs and F. Brünnow. 8vo. London, 1874.
- British Almanac and Companion.* 12mo. London, v. y.
- BRITISH ASSOCIATION *Reports.* 8vo. London, v. y.
- BROCKLESBY, J., *Elements of Astronomy for Schools and Academies.* 3rd ed. cr. 8vo. New York, 1857.
- BROWN, R., Jun., *The Law of Kosmic Order.* London, 1882.
- Eridanus River and Constellation, A Study of Archaic Southern Asterism.* London, 1883.
- BRUHNS, C., *Handbuch der Logarithmen.* 8vo. Leipzig, 1870.
- BRÜNNOW, F., *Lehrbuch der sphärischen Astronomie.* 2nd ed. 8vo. Berlin, 1862.
- Spherical Astronomy.* Trans. by Main. 8vo. Cambridge, 1860.
- Spherical Astronomy.* Trans. by Author. 8vo. London, 1865.
- CAREY, Geo. G., *Astronomy.* 8vo. London, 1836.
- *CARL, PH., *Repertorium der Cometen-Astronomie.* München, 1864.
- Die Principien der astronomischen Instrumentenkunde.* 8vo. Leipzig, 1883.
- CHALMERS, Dr., *Astronomical Discourses.* Edinburgh, 1857.
- CHAUVENET, W., *A Manual of Spherical and Practical Astronomy,* 2nd ed. 2 vols. 8vo. Philadelphia, 1864.
- CHRISTIE, J. R., *An Introduction to the Elements of Practical Astronomy.* 8vo. London, 1853.
- ✓ *CHRISTIE, W. H. M., *Astronomy.* Fcp. 8vo. 1875. S.P.C.K.
- CLARK, Latimer. *A Treatise on the Transit Instrument.* 8vo. London, 1882.

- CLERKE, Agnes M., *History of Astronomy during the 19th Century*. 2nd ed. Edinburgh, 1887.
- COLLINGWOOD, W. G., *Astrology in the Apocalypse*. London, 1886.
- Comptes Rendus de l'Académie des Sciences*. 4to. Paris, v. y.
- COMSTOCK, J. L., and HOBLYN, R. D., *Astronomy, with questions on each page*. Fcap. 8vo. London, 1851.
- Connaissance des Temps*. 8vo. Paris, v. y.
- COOPER, E. J., *Cometic Orbits*. 8vo. Dublin, 1852.
- COSTARD, Rev. G., *History of Astronomy*. 4to. London, 1767. [Scarcely a "History," but interesting as a "Miscellany."]
- DELABRE, J. B., *Histoire d'Astronomie—Ancienne—du Moyen Age—et Moderne*. 5 vols. 4to. Paris, 1817-21. Another volume appeared in 1827.
- Astronomie, théorique et pratique*. 3 vols. 4to. Paris, 1814.
- Abrégé d'Astronomie ou leçons élémentaires*. 8vo. Paris, 1813.
- *DELAUNAY, C., *Cours Élémentaire d'Astronomie*. 4th ed. Paris, 1864.
- DICK, T., LL.D., *The Solar System*. London, n. d.
- The Sidereal Heavens*. London, 1840.
- The Practical Astronomer*. London, 1845.
- Celestial Scenery*. London, 1837.
- DRAYSON, Capt. A. W., *The Common Sights of the Heavens, and how to see and know them*. 2nd ed. 16mo. London, 1862.
- DREW, J., *Manual of Astronomy*. 2nd ed. 16mo. London, 1853.
- DUBOIS, E., *Cours d'Astronomie*. 2nd ed. 8vo. Paris, 1865.
- *DUNKIN, E. *The Midnight Sky*. Imp. 8vo. London, 1869. R. T. Society.
- Encyclopædia Britannica*. 4to. Edinburgh, 1874.
- ENGELMANN, R., *Ueber die Helligkeitsverhältnisse der Jupiterstrabanten*. Leipzig, 1871.
- ENGLEFIELD, Sir H., *On the Determination of the Orbits of Comets, according to the Methods of Boscovitch and La Place*. 4to. London, 1793.
- English Cyclopædia, Arts and Sciences Division*. 8 vols. 4to. London, 1859-61.
- EVERS, H., LL.D., *Elementary Treatise on Nautical Astronomy*. [In Collins's Series.] 1873.
- FAYE, H., *Leçons de Cosmographie*. 2nd ed. 8vo. Paris, 1854.
- FERGUSON, J., *Astronomy*. 2nd ed. 4to. London, 1757.
- Astronomy familiarly explained in ten dialogues*. 8vo. Dublin, 1768.
- FERGUSON, J., and BREWSTER, D., *Astronomy explained upon Sir I. Newton's Principles*. 2nd ed. 2 vols. 8vo. Edinburgh, 1821.
- FINDLATER, A., LL.D., *Astronomy*. 16mo. Edinburgh, 1884.
- ✓ FLAMMARION, C., *Etudes et Lectures sur l'Astronomie*. 4 vols. 16mo. Paris, 1867.
- L'Atmosphère, description des grands phénomènes de la Nature*. 8vo. Paris, 1872.
- Petite Astronomie descriptive*. Paris, 1877.
- ✓ FLAMSTEED, Rev. J., *Account of his Life*, by F. Baily. 4to. London, 1837.
- FREND, W., *Evening Amusements, or the Beauty of the Heavens displayed*. 19 annual vols. 12mo. London, 1804-22.

- GALBRAITH, Rev. J., and HAUGHTON, Rev. S., *Manual of Astronomy*. New and enlarged edition. 18mo. London, n. d.
- Manual of Optics*. 18mo. London, 1857.
- GALILEO, G., *Opere*. 16 vols. 8vo. Firenze, 1842-56.
- GALL, J., *An Easy Guide to the Constellations*. Edinburgh, n. d.
- GASSENDI, P., *Omnia Opera*. 6 vols. fol. Florentiæ, 1727.
- GAUSS, C. F., *Theoria motus corporum coelestium*. 4to. Hamburgi, 1809.
- Theorie der Bewegung der Himmels Körper...ins Deutsche übertragen von C. Haase*. 4to. Hannover, 1865.
- Théorie du Mouvement des corps célestes...traduction par E. Dubois*. 8vo. Paris, 1864.
- GIBERNE, Agnes, *Sun, Moon, and Stars*. London, 1880.
- ✓ GODFRAY, H., *Treatise on Astronomy for Colleges and Schools*. 2nd ed. 8vo. London, 1874.
- GORE, J. E., *Planetary and Stellar Studies*. London, 1888.
- ✓ GRANT, R., *History of Physical Astronomy*. 8vo. London, 1852.
- GRAVIER, COULVIER-, *Recherches sur les Etoiles Filantes*. 8vo. Paris, 1847.
- Greenwich Observations*. 4to. London, v. y.
- GREGORY, O., *Treatise on Astronomy*. 8vo. London, 1802.
- ✓ GRIMTHORPE, Lord, *Astronomy without Mathematics*. 6th ed. 8vo. London, 1876. S.P.C.K.
- GUILLEMEN, A., *Le Soleil*. 12mo. Paris, 1869.
- La Lune*. 12mo. Paris, 1866.
- Les Comètes*. 8vo. Paris, 1875. English Edition: *The World of Comets*. Translated by Glaisher. London, 1877.
- Le Ciel, Notions d'Astronomie*. 5th ed. 8vo. Paris, 1876. English Edition: *The Heavens*. Trans. by Lockyer. 9th ed. 8vo. London, 1883.
- *Guy's *Elements of Astronomy, and an Abridgement of Keith's New Treatise on the Use of Globes*. 30th ed. fcap. 8vo. Philadelphia, 1853. 6th ed., London, 1843.
- HALL, Rev. T. G., *Outlines of Astronomy*. 15th ed. 24mo. London, 1861.
- HALLEY, E., *Astronomical Tables, with Precepts both in English and Latin*. 4to. London, 1752.
- HARDCASTLE, W., *Familiar Lessons, or a Simple Catechism of Astronomy*. 2nd ed. 24mo. London, n. d.
- HARLEY, Rev. T., *Moön Lore*. 8vo. London, 1885.
- HASKOLL, *Land and Marine Surveying*. 8vo. London.
- HAUGHTON, Rev. S., *Manual of Tides and Tidal Currents*. 4th ed. 18mo. 1870.
- HENDERSON, E., *A Treatise on Astronomy*. 2nd ed. 12mo. London, 1843.
- HERODOTUS, *Helicarnasseus*, ed. Rev. G. Rawlinson. 4 vols. 8vo. London, 1859-60.
- HERPIN, A., *Dictionnaire Astronomique*. 8vo. Paris, 1875.
- *HERSCHEL, Sir J. F. W., *Outlines of Astronomy*. 12th ed. 8vo. London, 1873.
- Results of Astronomical Observations made during the Years 1834-8 at the Cape of Good Hope*. 4to. London, 1847.
- HEVELIUS, J., *Cometographia, totam naturam cometarum . . . exhibens*. Fol. Gedani, 1668.
- Prodromus Astronomiæ*. Fol. Gedani, 1660.
- Mercurius in Sole visus*. Fol. Gedani, 1662.
- Selenographia, sive Lunæ descriptio*. Fol. Gedani, 1647.

- HILL, J., *Urania, or a compleat View of the Heavens . . . in form of a Dictionary*, 4to. London, 1754.
- HIND, J. R., **Introduction to Astronomy*. 8vo. London, 1863.
 **Solar System*. 3rd ed. 12mo. London, 1863.
 **The Comets*. 12mo. London, 1852.
The Comet of 1556. 12mo. London, 1857.
- History of Astronomy*, Library of Useful Knowledge. 8vo. London, 1834.
- HOOKE, R., *Attempt to prove the Motion of the Earth from Observation*. 4to. London, 1674.
- HUGENIUS, C., ΚΟΣΜΟΘΕΩΡΟΣ, *sive de Terris Cœlestibus, earumque ornatu, conjecturæ*. 2nd ed. 4to. Hagæ Comitum, 1699.
Systema Saturnium. Hagæ Comitum, 1659.
Opera Variâ. 2 vols. 4to. Lugduni Batavorum, 1724.
- HUMBOLDT, A. VON, *Cosmos*. Translated by E. C. Otté. 5 vols. 8vo. London, 1849-58.
- HUTTON, C., *Mathematical and Philosophical Dictionary*. 2nd ed. 2 vols. 4to. 1815.
- IDELER, L., *Untersuchungen über den Ursprung und die Bedeutung der Sternnamen*. 8vo. Berlin, 1809.
- JAHN, G. A., *Geschichte der Astronomie vom Anfange des neunzehnten Jahrhunderts bis zu Ende des Jahres 1842*. 2 vols. 8vo. Leipzig, 1844.
- JEANS, Rev. G., *Practical Astronomy for the Unlearned*. 8vo. London, 1856.
- JEANS, J. W., *Handbook for finding the Stars*. Ed. by W. R. Martin. 4th ed. London, 1888.
- JOHNSON, Rev. S. J., F.R.A.S. *Eclipses past and future*. London, 1874.
- *JOHNSTON, A. K., *Atlas of Astronomy*, ed. Hind. 8vo. Edinburgh, 1855.
Physical Atlas. Fol. Edinburgh, 1849.
- KAISER, F., *Der Sternenhimmel beschrieben, mit einem Vorwort von J. F. Encke*. 8vo. Berlin, 1850.
- KEITH, T., *Treatise on the Globes*, ed. Rowbotham. 8vo. London, 1844.
- KEPLER, J., *Ad Vitellionem Paralipomena, quibus Astronomiæ pars optica traditur*. 4to. Francofurti, 1604.
De Stellâ novâ in Pede Serpentarii. 4to. Pragæ, 1606.
De Motibus Stellæ Martis, ex observationibus Tychoonis Brahe. Fol. Pragæ, 1609.
Epitome Astronomiæ Copernicanæ Libri tres priores de doctrinâ sphericâ. 8vo. Lentiis ad Danubium, 1618.
Opera Omnia, ed. Ch. Frisch. 8 vols. 8vo. Frankofurti-a-M., 1857-70.
- KERIGAN, T., *A Practical Treatise on the Eclipses of the Sun and Moon . . . explaining their calculation by simple and direct Methods*. 8vo. London, 1844.
- KIDDLE, H., *A Manual of Astronomy and the use of the Globes for Schools and Academies*. 10th ed. cr. 8vo. New York, 1854.
- KITCHINER, *Telescopes*. London, 1825.
- KLINKERFUES, W., *Theoretische Astronomie*. 8vo. Braunschweig, 1871.

KNIGHT, Rev. R., *The Plurality of Worlds*. London, 1855.

KURTZ, T. H., *Bibel und Astronomie*. 5th ed. Berlin, 1865.

LA GRANGE, J. L., *Mécanique Analytique*. 3rd ed., edited by J. Bertrand. 2 vols. 4to. 1853-5.

LALANDE, J. De, *Astronomie*. 4 vols. 4to. Paris, 1792.

Bibliographie Astronomique avec l'Histoire de l'Astronomie depuis 1781 jusqu'à 1802. 4to. Paris, 1803.

LANGLER, J. R., *The Main Facts of Popular Astronomy and Mathematical Geography*. Fcap. 8vo. London, 1871.

LANGLEY, S. P., *The New Astronomy*. 8vo. Boston, U.S., 1888.

LAPLACE, P. S. De, *Exposition du Système du Monde*. 4th ed. 2 vols. 8vo. Paris, 1813.

Traité de Mécanique Céleste. 5 vols. 4to. Paris, 1798-1827.

Mécanique Céleste . . . translated with a Commentary by N. Bowditch. 4 vols. 4to. Boston, U.S., 1829-39.

LARDNER, D., *Handbook of Astronomy*. 2 vols. 12mo. London, 1853; also 2nd ed., ed. E. Dunkin. 1 vol. 12mo. London, 1860.

Museum of Science and Art. 12 vols. 12mo. London, 1854-6.

L'Art de vérifier les Dates des Faits Historiques, des Chartes, des Chroniques, et d'autres anciens Monuments, depuis la Naissance de Notre Seigneur, par le moyen d'une Table Chronologique. 3 vols. fol. Paris, 1783.

LEDGER, Rev. E., *The Sun, its Planets and their Satellites*. [Gresham Lectures.] London, 1882.

LEWIS, Sir G. C., *An Historical Survey of the Astronomy of the Ancients*. 8vo. Lond. 1862.

LIAIS, E., *Traité d'Astronomie*. 8vo. Paris, 1867.

L'Espace céleste . . . description physique de l'Univers. 8vo. Paris.

LINDENAU, VON, *Zeitschrift für Astronomie*. 5 vols. 8vo. Tübingen, 1816-18.

LINNINGTON, R. T., *Compendium of Astronomy . . . and Astronomical Dictionary*. 12mo. London, 1830.

LITROW, J. J., *Die Wunder des Himmels*. 4th ed. Stuttgart, 1854.

✓ LOCKYER, J. N., *The Movements of the Earth*. London, 1887.

Elementary Lessons in Astronomy. London, 1886.

Studies in Spectrum Analysis. 4th ed. London, 1886.

Astronomy. Science Primer. London, 1886.

LOOMIS, E., *Recent Progress of Astronomy, especially in the United States*. 3rd ed. 8vo. New York, 1856.

**Practical Astronomy*. 7th ed. 8vo. New York, 1886.

Treatise on Astronomy. 8vo. New York, 1867.

Treatise on Meteorology. 8vo. New York, 1868.

Elements of Astronomy for Academies and High Schools. New York, 1869.

LUBIENITZ, S. De, *Theatrum Cometicum*. 2 vols. fol. Amsterdam, 1668.

LUCRETIUS, *De Rerum Naturâ*, trans. Watson, vol. 26, Bohn's *Class. Library*. 8vo. London, 1851.

LYNN, W. T., F.R.A.S., *Celestial Motions*. 6th ed. London, 1889.

M'INTIRE, J., M.D., *A New Treatise on Astronomy and the Use of the Globes*. Cr. 8vo. New York, 1860.

- MÄDLER, J. H., *Populäre Astronomie*. 5th ed. 8vo. Berlin, 1861.
 **Kurzer Abriss der Astronomie*. 8vo. Essen, 1863.
Geschichte der Himmelskunde nach ihrem gesammten Umfange. 2 vols. 8vo. Braunschweig, 1872-73.
Reden und Abhandlungen über Gegenstände der Himmelskunde. 8vo. Berlin, 1870.
- MAGNAGHI, G. B., *Gli strumenti a Riflessione per misurare angoli*. 8vo. Milan, 1875.
- MAILLA, J. A. M. De, *Histoire Générale de la Chine*. 4to. Paris, 1776 et seq.
- MAILLY, E., *Tableau d'Astronomie dans l'Hémisphère austral et dans l'Inde*. 8vo. Bruxelles, 1872.
- MAIN, Rev. R., *Practical and Spherical Astronomy for the use chiefly of Students in the Universities*. 8vo. Cambridge, 1863.
Rudimentary Treatise on Astronomy, Weale's Series, vol. 96. 12mo. London, 1852.
- MANILIUS, *Astronomicum, in usum Delphinum*. Ed. by Pingré. 2 vols. 8vo. Paris. In English Verse. 8vo. London, 1697.
- MANN, R. J., M.D., F.R.A.S., *The Heavens, a Guide to Astronomical Science*. 24mo. London, n. d.
- MATTISON, H., A.M., *A High School Astronomy, in which the Descriptive, Physical and Practical are combined*. Cr. 8vo. New York, 1854.
 **A Primary Astronomy for Schools and Families*. [Q. and A.] Cr. 8vo. New York, 1853.
- MILLER, R. K., *The Romance of Astronomy*. 3rd ed. London, 1882.
- MILLER, W. S. S. C., *The Heavenly Bodies, their nature and habitability*. 8vo. London, 1883.
- MILNER, Rev. T., *Gallery of Nature*. 2nd ed. 8vo. London, 1859.
- MITCHEL, O. M., *The Orbs of Heaven*. 8vo. London, 1853.
Popular Astronomy. Revised by Rev. L. Tomlinson, M.A. London, 1860.
Astronomy of the Bible. New York, 1863.
- MONTEMONT, A., *Lettres sur l'Astronomie*. 4 vols. 24mo. Paris, 1823. [Vol. i. contains a Vocabulary.]
- MONTUCLA, J. F., *Histoire des Mathématiques*. Ed. Lalande. 4 vols. 8vo. Paris, 1799-1802.
Moon, The. Fcap. 8vo. London, n. d. (S.P.C.K.)
- MORGAN, A. De, *The Book of Almanacs*. Oblong 8vo. London, 1851.
- MORTON, E. J. C. *Heroes of Science. Astronomers*. (S.P.C.K.) London, 1882.
- MOSELEY, Rev. H., *Lectures on Astronomy*. 12mo. London, 1850.
Astro-Theology. 3rd ed. fcap. 8vo. London, 1860.
- NAGY, K., *Die Sonne und die Astronomie*. Imp. 8vo. Leipzig, 1866.
- NARRIEN, J., *Origin and Progress of Astronomy*. 8vo. London, 1833.
- ✓ NASMYTH, J., and CARPENTER, J., *The Moon*. 4to. London, 1874.
 **Nautical Almanac*. 8vo. London, v. y.
- NEISON, E., *The Moon, and the condition and configuration of its surface*. 8vo. London, 1876.
- NEWCOMB, S., LL.D., *Popular Astronomy*. 2nd ed. 8vo. London, 1883.
- NICHOL, J. P., *Thoughts on some important points relating to the System of the World*. Edinburgh, 1846.
Architecture of the Heavens. 9th ed. 8vo. London, 1851.
Cyclopædia of the Physical Sciences. 2nd ed. 8vo. London, 1860.

- NOBLE, Capt. W., *Hours with a 3-in. Telescope*. 2nd ed. 8vo. London, 1887.
- NORIE, J. W., *Epitome of Practical Navigation*. 8vo. London, 1868.
- *NORTON, W. A., *An Elementary Treatise on Astronomy . . . with Tables*. 3rd ed. 8vo. New York, 1852.
- NÜRNBERGER, J. E., *Populäres astronomisches Hand-Wörterbuch*, vol. i. A-K. 8vo. Kempten, 1846.
- OLBERS, W., *Abhandlung über die leichteste und bequemste Methode die Bahn eines Cometen zu berechnen*. 2nd ed. Ed. by Encke. Weimar, 1847.
- OLIVER, J. A. W., *Astronomy for Amateurs*. London, 1888.
- OLMSTED, D., *Mechanism of the Heavens*. 8vo. Edinburgh, 1860.
- PARKER, R. G., *Astronomy, with Questions for Examination*. [In Parker's Educational Course.] Fcp. 8vo. London, 1855.
- PARKES, S. H., *Unfinished Worlds*. 2nd ed. 8vo. London, 1888.
- PEARSON, Rev. Jas., *An Elementary Treatise on the Tides*. 8vo. London, 1881.
- PEARSON, Rev. W., *Introduction to Practical Astronomy*. 2 vols. 4to. London, 1824-9.
- PETAVIUS, D., *Uranologion : Systema variorum auctorum de Sphæra*. Folio. Lutet. 1630.
- PETIT, F., *Traité d'Astronomie pour les gens du Monde*. 2 vols. 16mo. Paris, 1866.
- Philosophical Journal*. 8vo. Edinburgh, v. y.
- Philosophical Magazine*. 8vo. London, v. y.
- Pictures of the Heavens*. 2nd ed. fcap. 8vo. London, 1859.
- PINGRE, A., *Cométographie ; ou Traité historique et théorique des Comètes*. 2 vols. 4to. Paris, 1783.
- PLUMMER, J. I., *Introduction to Astronomy*. [In Collins's Series.] Glasgow and London, 1872.
- Plurality of Worlds, Of the*. 3rd ed. London, 1854.
- PONTÉCOULANT, G. de, *Théorie analytique du système du Monde*. 2nd ed. 3 vols. Paris, 1856.
- Traité élémentaire de physique céleste, ou Précis d'Astronomie théorique et pratique*. 8vo. Paris, 1840.
- ✓ PROCTOR, R. A., *Saturn and its System*. 8vo. London, 1865.
- The Sun*. 3rd ed. 8vo. London, 1876.
- The Moon*. 8vo. London, 1873.
- Elementary Astronomy*. 3rd ed. Fcap. 8vo. London, 1873.
- PTOLEMÆUS CLAUDIUS, *Almagestum*. Fol. Colon., 1515.
- QUETELET, A., *Eléments d'Astronomie*. 12mo. Paris, 1847.
- REES, A., *Cyclopædia of Arts, Sciences, and Literature*. 45 vols. 4to. London, 1819.
- RICCIOLI, J. B., *Almagestum Novum*. 2 vols. fol. Bononiæ, 1653.
- ROLLESTON, F., *Mazzeroth, or the Constellations*. 8vo. London, 1882.
- ROSCOE, H. E., *Spectrum Analysis, Six Lectures*. 2nd ed. 8vo. London, 1870.
- ROSSER, W. H., *The Stars ; how to know them and how to use them*. Imp. 8vo. London, 1867.
- ROYAL ASTRONOMICAL SOCIETY, *Memoirs*. 4to. London, v. y.
- **Monthly Notices*. 8vo. London, v. y.
- ROYAL IRISH ACADEMY, *Transactions*. 8vo. Dublin, v. y.

- ROYAL SOCIETY, *Philosophical Transactions*. 4to. London, v. y.
- ROYAL SOCIETY OF EDINBURGH, *Transactions*. 4to. Edinburgh, v. y.
- RUDOLPH, Prof., *The Wonders of Nature*. Revised by A. Brown, LL.D. London, n. d.
- RYAN, J., *The New American Grammar of the Elements of Astronomy*. Fcap. 8vo. New York, 1839.
- SAWITSCH, A., *Abriss der practischen Astronomie . . . aus dem Russischen übersetzt von Dr. W. C. Götze*. 2 vols. 8vo. Hamburg, 1850.
- SCHEINER, C., *Rosa Vrsina, sive Sol ex admirando Facularum & Macularum svarum phenomeno variis, &c.* Fol. Bracciani, 1629.
- SHELLEN, H., *Spectrum Analysis*. Translated by J. and C. Lassell, and edited with notes by Capt. W. De W. Abney, R.E., F.R.S. 8vo. 2nd ed. London, 1885.
- SCHLEGEL, G., *Uranographie chinoise, ou preuves directes que l'Astronomie primitive est originaire de la Chine*. 2 vols. 8vo. La Haye, 1875.
- SCHMIDT, J. F. J., *Das Zodiacallicht*. 8vo. 1856.
- SCHRÖTER, J. J., *Selenotopographische Fragmente zur genauern Kenntniss der Mondfläche*. 2 vols. 4to. Lilienthal, 1791-1802.
- SCHUBERT, F. T., *Traité d'Astronomie Théorique*. 3 vols. 4to. St. Pétersbourg, 1822.
- SECCHI, A., *Quadro Fisico del Sistema Solare*. 16mo. Roma, 1859.
- SEIDEL, L., *Untersuchungen über die gegenseitigen Helligkeiten der Fixsterne erster Grösse, &c.* Munich, 1852.
- SHADWELL, Capt. C. F. A., *Notes on the Management of Chronometers*. 8vo. London, 1861.
- SIMMS, W., *The Achromatic Telescope*. 8vo. London, 1852.
- SMYTH, C. P., *Teneriffe; an Astronomer's Experiment*. 8vo. London, 1858.
- *SMYTH, W. H., *Cycle of Celestial Objects*. 2 vols. 8vo. London, 1844.
- Speculum Hartwellianum*. 4to. London, 1860.
- Sidereal Chromatics*. 8vo. London, 1864.
- SNOOKE, W. D., *Brief Astronomical Tables for the expeditious Calculation of Eclipses*. 8vo. London, 1852.
- SOMERVILLE, MARY, *Connexion of the Physical Sciences*. 9th ed. 8vo. London.
- Mechanism of the Heavens*. 8vo. London.
- STEELE, J. D., Ph.D., *New Descriptive Astronomy*. New York, n. d.
- Fourteen weeks in Astronomy*. 8vo. New York.
- STUART, J., M.A., *A Chapter of Science*. (S.P.C.K.)
- ✓ STRUVE, F. G. W., *Etudes d'Astronomie Stellaire*. 8vo. St. Petersburg, 1847.
- TATE, T., *Astronomy and the use of the Globes*. [In Gleig's School Series.] 24mo. London, 1858.
- THEOPHRASTUS, *Opera Omnia*. Ed. Heinsius. Fol. Lugduni Batavorum, 1613.
- THOMSON, D. P., *Introduction to Meteorology*. 8vo. Edinburgh, 1849.
- Tides, The*. Fcap. 8vo. London, 1857. (S.P.C.K.)
- *TOMLINSON, Rev. L., *Recreations in Astronomy*. 5th ed. 16mo. London, 1858.
- URSINUS, G. F., *Logarithmi VI Decimalium . . . quibus additi sunt varii Logarithmi et numeri sæpius in Mathesi adhibiti*. 8vo. Hafniæ, 1827.
- VINCE, Rev. S., *Complete System of Astronomy*. 3 vols. 4to. Cambridge, 1797-1808.

- WARD, HON. MRS., *The Telescope. Objects coming within the range of a small one.* 5th ed. London, 1879.
- WARREN, H. W., D.D., *Recreations in Astronomy.* New York, 1886.
- WATSON, J. C., *Theoretical Astronomy . . . with auxiliary Tables.* 8vo. Philadelphia, 1868.
- *WEBB, Rev. T. W., *Celestial Objects for common Telescopes.* 4th ed., revised and greatly enlarged. 16mo. London, 1881.
The Sun and his Phenomena. 16mo. London, 1885.
- WHEWELL, Rev. W., *Astronomy and general Physics considered with reference to Natural Theology.* 8vo. London, 1833. [Vol. iii. of the "Bridgewater Treatises."]
History of the Inductive Sciences. 3 vols. 3rd ed., with additions. London, 1857.
- WHITING, T., *A Comprehensive System of Astronomy, both Theoretic and Practical.* 4to. London, 1828. [Contains a very full vocabulary of definitions.]
- WILLARD, E., *Astronography, or Astronomical Geography.* [In Cassell's Educational Course.] 8vo. London, n. d.
- WILLIAMS, W. M., *The Fuel of the Sun.* 8vo. London, 1870.
- WILSON, Rev. T., *Catechism of Astronomy.* Fcap. 8vo. London, n. d.
- WING, V., *Astronomia Britannica.* Fol. London, 1669.
- WOLF, R., *Taschenbuch für Mathematik, Physik, Geodäsie und Astronomie.* 4th ed. 16mo. Zürich, 1869.
Handbuch der Mathematik . . . und Astronomie. 2 vols. 8vo. Zürich, 1872.
Geschichte der Astronomie. 8vo. München, 1877.
Wonders of the Heavens displayed in 20 Lectures. 12mo. London, 1821.
- WRIGHT, T., *An original Theory or new Hypothesis of the Universe.* 4to. London, 1750.
- YOUNG, C. A., Ph.D., LL.D., *A Textbook of General Astronomy for Colleges and Scientific Schools.* 8vo. Boston, U.S., 1888.
The Sun. 3rd ed., with Supplementary Note. London, 1888.
- ZACH, F. VON, *Monatliche Correspondenz zur Beförderung der Erd- und Himmelskunde.* 26 vols. 8vo. Gotha, 1800-13. With a Register or general Index by J. G. Galle. 8vo. Gotha, 1850.
Correspondence Astronomique. 14 vols. 8vo. Gènes, 1818-26.
- ZÖLLNER, J. C. F., *Über die Natur der Cometen. Beiträge zur Geschichte und Theorie der Erdkenntniss.* 8vo. Leipzig, 1872.

BOOK XIII.

ASTRONOMICAL TABLES.

Other forms of Tables for the Conversion of Sidereal and Mean Time (which some persons may prefer) will be found in Sheepshanks's *Tables for facilitating Astronomical Reductions*, 4to. London, 1846; and in the *Berliner Astronomisches Jahrbuch*, every year.

I. FOR CONVERTING INTERVALS OF MEAN SOLAR TIME

HOURS.		MINUTES.				SECONDS.			
Hours of Mean Time.	Equivalents in Sidereal Time.	Minutes of Mean Time.	Equivalents in Sidereal Time.	Minutes of Mean Time.	Equivalents in Sidereal Time.	Seconds of Mean Time.	Equivalents in Sidereal Time.	Seconds of Mean Time.	Equivalents in Sidereal Time.
	h. m. s.		m. s.		m. s.		s.		s.
1	1 0 9.85	1	1 0.16	31	31 5.09	1	1.00	31	31.08
2	2 0 19.71	2	2 0.32	32	32 5.25	2	2.00	32	32.08
3	3 0 29.56	3	3 0.49	33	33 5.42	3	3.00	33	33.09
4	4 0 39.42	4	4 0.65	34	34 5.58	4	4.01	34	34.09
5	5 0 49.28	5	5 0.82	35	35 5.74	5	5.01	35	35.09
6	6 0 59.13	6	6 0.98	36	36 5.91	6	6.01	36	36.09
7	7 1 8.99	7	7 1.14	37	37 6.07	7	7.01	37	37.10
8	8 1 18.85	8	8 1.31	38	38 6.24	8	8.02	38	38.10
9	9 1 28.70	9	9 1.47	39	39 6.40	9	9.02	39	39.10
10	10 1 38.56	10	10 1.64	40	40 6.57	10	10.02	40	40.10
11	11 1 48.42	11	11 1.80	41	41 6.73	11	11.03	41	41.11
12	12 1 58.27	12	12 1.97	42	42 6.89	12	12.03	42	42.11
13	13 2 8.13	13	13 2.13	43	43 7.06	13	13.03	43	43.11
14	14 2 17.99	14	14 2.29	44	44 7.22	14	14.03	44	44.12
15	15 2 27.84	15	15 2.46	45	45 7.39	15	15.04	45	45.12
16	16 2 37.70	16	16 2.62	46	46 7.55	16	16.04	46	46.12
17	17 2 47.56	17	17 2.79	47	47 7.72	17	17.04	47	47.12
18	18 2 57.41	18	18 2.95	48	48 7.88	18	18.04	48	48.13
19	19 3 7.27	19	19 3.12	49	49 8.04	19	19.05	49	49.13
20	20 3 17.12	20	20 3.28	50	50 8.21	20	20.05	50	50.13
21	21 3 26.98	21	21 3.44	51	51 8.37	21	21.05	51	51.13
22	22 3 36.84	22	22 3.61	52	52 8.54	22	22.06	52	52.14
23	23 3 46.69	23	23 3.77	53	53 8.70	23	23.06	53	53.14
24	24 3 56.55	24	24 3.94	54	54 8.87	24	24.06	54	54.14
		25	25 4.10	55	55 9.03	25	25.06	55	55.15
		26	26 4.27	56	56 9.19	26	26.07	56	56.15
		27	27 4.43	57	57 9.36	27	27.07	57	57.15
		28	28 4.59	58	58 9.52	28	28.07	58	58.15
		29	29 4.76	59	59 9.69	29	29.07	59	59.16
		30	30 4.92	60	60 9.85	30	30.08	60	60.16

INTO EQUIVALENT INTERVALS OF SIDEREAL TIME.

FRACTIONS OF A SECOND.

Seconds of Mean Time.	Equivalents in Sidereal Time.	Seconds of Mean Time.	Equivalents in Sidereal Time.	Seconds of Mean Time.	Equivalents in Sidereal Time.
	s.		s.		s.
0.01	0.010	0.34	0.340	0.67	0.671
0.02	0.020	0.35	0.350	0.68	0.681
0.03	0.030	0.36	0.360	0.69	0.691
0.04	0.040	0.37	0.371	0.70	0.701
0.05	0.050	0.38	0.381	0.71	0.711
0.06	0.060	0.39	0.391	0.72	0.721
0.07	0.070	0.40	0.401	0.73	0.732
0.08	0.080	0.41	0.411	0.74	0.742
0.09	0.090	0.42	0.421	0.75	0.752
0.10	0.100	0.43	0.431	0.76	0.762
0.11	0.110	0.44	0.441	0.77	0.772
0.12	0.120	0.45	0.451	0.78	0.782
0.13	0.130	0.46	0.461	0.79	0.792
0.14	0.140	0.47	0.471	0.80	0.802
0.15	0.150	0.48	0.481	0.81	0.812
0.16	0.160	0.49	0.491	0.82	0.822
0.17	0.170	0.50	0.501	0.83	0.832
0.18	0.180	0.51	0.511	0.84	0.842
0.19	0.190	0.52	0.521	0.85	0.852
0.20	0.200	0.53	0.531	0.86	0.862
0.21	0.210	0.54	0.541	0.87	0.872
0.22	0.220	0.55	0.551	0.88	0.882
0.23	0.230	0.56	0.561	0.89	0.892
0.24	0.240	0.57	0.571	0.90	0.902
0.25	0.250	0.58	0.581	0.91	0.912
0.26	0.260	0.59	0.591	0.92	0.922
0.27	0.270	0.60	0.601	0.93	0.932
0.28	0.280	0.61	0.611	0.94	0.942
0.29	0.290	0.62	0.621	0.95	0.952
0.30	0.300	0.63	0.631	0.96	0.962
0.31	0.310	0.64	0.641	0.97	0.972
0.32	0.320	0.65	0.651	0.98	0.982
0.33	0.330	0.66	0.661	0.99	0.992

This TABLE is useful for the conversion of MEAN SOLAR into SIDEREAL TIME.

Sidereal Time required = Sidereal Time at the preceding Mean Noon + the Equivalent to the given Mean Time.

EXAMPLE.—To convert 2^h 22^m 25.62^s Mean Time at Greerwich, Jan. 7, 1870, into Sidereal Time.

Sidereal Time at the preceding Mean Noon, viz. Jan. 7	h.	m.	s.
	19	7	23.78
For Mean Intervals.	2 ^h	0 ^m	0 ^s
	22	0	
	25	0	62
	The Table gives the Equivalent Sidereal Intervals.		
	22	3.61	
	25	0.62	
The Sum is the Sidereal Time required	...	21	30 12.78

II. FOR CONVERTING INTERVALS OF SIDEREAL TIME

HOURS.			MINUTES.						SECONDS.						
Hours of Sidereal Time.	Equivalents in Mean Time.			Minutes of Sidereal Time.	Equivalents in Mean Time.		Minutes of Sidereal Time.	Equivalents in Mean Time.		Seconds of Sidereal Time.	Equiva- lents in Mean Time.		Seconds of Sidereal Time.	Equiva- lents in Mean Time.	
	h.	m.	s.		m.	s.		m.	s.		s.	s.			
1	0	59	50.17	1	0	59.83	31	30	54.92	1	0.99	31	30.91		
2	1	59	40.34	2	1	59.67	32	31	54.75	2	1.99	32	31.91		
3	2	59	30.51	3	2	59.50	33	32	54.59	3	2.99	33	32.90		
4	3	59	20.68	4	3	59.34	34	33	54.42	4	3.98	34	33.90		
5	4	59	10.85	5	4	59.18	35	34	54.26	5	4.98	35	34.90		
6	5	59	1.02	6	5	59.01	36	35	54.10	6	5.98	36	35.90		
7	6	58	51.19	7	6	58.85	37	36	53.93	7	6.98	37	36.89		
8	7	58	41.36	8	7	58.68	38	37	53.77	8	7.97	38	37.89		
9	8	58	31.53	9	8	58.52	39	38	53.61	9	8.97	39	38.89		
10	9	58	21.70	10	9	58.36	40	39	53.44	10	9.97	40	39.89		
11	10	58	11.87	11	10	58.19	41	40	53.28	11	10.97	41	40.88		
12	11	58	2.04	12	11	58.03	42	41	53.11	12	11.96	42	41.88		
13	12	57	52.21	13	12	57.87	43	42	52.95	13	12.96	43	42.88		
14	13	57	42.38	14	13	57.70	44	43	52.79	14	13.96	44	43.87		
15	14	57	32.55	15	14	57.54	45	44	52.62	15	14.95	45	44.87		
16	15	57	22.72	16	15	57.37	46	45	52.46	16	15.95	46	45.87		
17	16	57	12.89	17	16	57.21	47	46	52.30	17	16.95	47	46.87		
18	17	57	3.06	18	17	57.05	48	47	52.13	18	17.95	48	47.86		
19	18	56	53.23	19	18	56.88	49	48	51.97	19	18.94	49	48.86		
20	19	56	43.40	20	19	56.72	50	49	51.80	20	19.94	50	49.86		
21	20	56	33.57	21	20	56.55	51	50	51.64	21	20.94	51	50.86		
22	21	56	23.74	22	21	56.39	52	51	51.48	22	21.93	52	51.85		
23	22	56	13.92	23	22	56.23	53	52	51.31	23	22.93	53	52.85		
24	23	56	4.09	24	23	56.06	54	53	51.15	24	23.93	54	53.85		
				25	24	55.90	55	54	50.98	25	24.93	55	54.84		
				26	25	55.74	56	55	50.82	26	25.92	56	55.84		
				27	26	55.57	57	56	50.66	27	26.92	57	56.84		
				28	27	55.41	58	57	50.49	28	27.92	58	57.84		
				29	28	55.24	59	58	50.33	29	28.92	59	58.83		
				30	29	55.08	60	59	50.17	30	29.91	60	59.83		

INTO EQUIVALENT INTERVALS OF MEAN SOLAR TIME.

FRACTIONS OF A SECOND.

Seconds of Sidereal Time.	Equivalents in Mean Time.	Seconds of Sidereal Time.	Equivalents in Mean Time.	Seconds of Sidereal Time.	Equivalents in Mean Time.
s.	s.	s.	s.	s.	s.
0.01	0.009	0.34	0.339	0.67	0.668
0.02	0.019	0.35	0.349	0.68	0.678
0.03	0.029	0.36	0.359	0.69	0.688
0.04	0.039	0.37	0.368	0.70	0.698
0.05	0.049	0.38	0.378	0.71	0.708
0.06	0.059	0.39	0.388	0.72	0.718
0.07	0.069	0.40	0.398	0.73	0.728
0.08	0.079	0.41	0.408	0.74	0.737
0.09	0.089	0.42	0.418	0.75	0.747
0.10	0.099	0.43	0.428	0.76	0.757
0.11	0.109	0.44	0.438	0.77	0.767
0.12	0.119	0.45	0.448	0.78	0.777
0.13	0.129	0.46	0.458	0.79	0.787
0.14	0.139	0.47	0.468	0.80	0.797
0.15	0.149	0.48	0.478	0.81	0.807
0.16	0.159	0.49	0.488	0.82	0.817
0.17	0.169	0.50	0.498	0.83	0.827
0.18	0.179	0.51	0.508	0.84	0.837
0.19	0.189	0.52	0.518	0.85	0.847
0.20	0.199	0.53	0.528	0.86	0.857
0.21	0.209	0.54	0.538	0.87	0.867
0.22	0.219	0.55	0.548	0.88	0.877
0.23	0.229	0.56	0.558	0.89	0.887
0.24	0.239	0.57	0.568	0.90	0.897
0.25	0.249	0.58	0.578	0.91	0.907
0.26	0.259	0.59	0.588	0.92	0.917
0.27	0.269	0.60	0.598	0.93	0.927
0.28	0.279	0.61	0.608	0.94	0.937
0.29	0.289	0.62	0.618	0.95	0.947
0.30	0.299	0.63	0.628	0.96	0.957
0.31	0.309	0.64	0.638	0.97	0.967
0.32	0.319	0.65	0.648	0.98	0.977
0.33	0.329	0.66	0.658	0.99	0.987

This TABLE is useful for the conversion of SIDEREAL into MEAN SOLAR TIME.

Mean Solar Time required = Mean Time at the preceding Sidereal Noon + the Equivalent to the given Sidereal Time.

EXAMPLE.—To convert 21^h 30^m 12.80^s Sidereal Time at Greenwich, Jan. 7, 1870, into Mean Time.

Mean Time at the preceding Sidereal Noon, viz. Jan. 6	...	h. m. s.
		4 55 44.19
For Sidereal Intervals.	$\left\{ \begin{array}{l} 21^{\text{h}} 0^{\text{m}} 0^{\text{s}} \\ 30 \quad 0 \\ 12 \quad 0 \\ 0.80 \end{array} \right.$	$\left\{ \begin{array}{l} 20 56 33.57 \\ 29 55.08 \\ 11.96 \\ 0.79 \end{array} \right.$
The Sum is the Mean Time required, Jan. 7 ...		2 22 25.59

III.

IV.

FOR REDUCING LONGITUDE TO TIME. FOR REDUCING TIME TO LONGITUDE.

°	H. M.		°	H. M.		Degrees.	Hours.	Minutes.	Hours.	Degrees.	M. ° ' "			M. ° ' "					
	'	S.		'	S.						S.	'	"	S.	'	"	S.	'	"
	"	T.		"	T.						T.	"	"	T.	"	"	T.	"	"
1	0	4	31	2	4	70	4	40	1	15	1	0	15	31	7	45			
2	0	8	32	2	8	80	5	20	2	30	2	0	30	32	8	0			
3	0	12	33	2	12	90	6	0	3	45	3	0	45	33	8	15			
4	0	16	34	2	16	100	6	40	4	60	4	1	0	34	8	30			
5	0	20	35	2	20	110	7	20	5	75	5	1	15	35	8	45			
6	0	24	36	2	24	120	8	0	6	90	6	1	30	36	9	0			
7	0	28	37	2	28	130	8	40	7	105	7	1	45	37	9	15			
8	0	32	38	2	32	140	9	20	8	120	8	2	0	38	9	30			
9	0	36	39	2	36	150	10	0	9	135	9	2	15	39	9	45			
10	0	40	40	2	40	160	10	40	10	150	10	2	30	40	10	0			
11	0	44	41	2	44	170	11	20	11	165	11	2	45	41	10	15			
12	0	48	42	2	48	180	12	0	12	180	12	3	0	42	10	30			
13	0	52	43	2	52	190	12	40	13	195	13	3	15	43	10	45			
14	0	56	44	2	56	200	13	20	14	210	14	3	30	44	11	0			
15	1	0	45	3	0	210	14	0	15	225	15	3	45	45	11	15			
16	1	4	46	3	4	220	14	40	16	240	16	4	0	46	11	30			
17	1	8	47	3	8	230	15	20	17	255	17	4	15	47	11	45			
18	1	12	48	3	12	240	16	0	18	270	18	4	30	48	12	0			
19	1	16	49	3	16	250	16	40	19	285	19	4	45	49	12	15			
20	1	20	50	3	20	260	17	20	20	300	20	5	0	50	12	30			
21	1	24	51	3	24	270	18	0	21	315	21	5	15	51	12	45			
22	1	28	52	3	28	280	18	40	22	330	22	5	30	52	13	0			
23	1	32	53	3	32	290	19	20	23	345	23	5	45	53	13	15			
24	1	36	54	3	36	300	20	0	24	360	24	6	0	54	13	30			
25	1	40	55	3	40	310	20	40			25	6	15	55	13	45			
26	1	44	56	3	44	320	21	20			26	6	30	56	14	0			
27	1	48	57	3	48	330	22	0			27	6	45	57	14	15			
28	1	52	58	3	52	340	22	40			28	7	0	58	14	30			
29	1	56	59	3	56	350	23	20			29	7	15	59	14	45			
30	2	0	60	4	0	360	24	0			30	7	30	60	15	0			

The first of the two preceding tables is used for reducing longitude to time, at the rate of 15° to 1^h .

The degrees, minutes, or seconds are given in the odd columns, and the corresponding time in the even columns. When the 1st column is reckoned degrees, the 2nd is hours and minutes of time; and when the 1st is minutes of arc, the 2nd is minutes and seconds of time; and so on.

EXAMPLE:—Convert $161^\circ 5' 20''$ of longitude into time.

		h.	m.	s.
160°	=	10	40	0
1°	=		4	0
5'	=			20
20''	=			1.3
Required time		10	44	21.3

The 2nd table is the converse of the 1st. The time is given in the odd, and the longitude in the even columns. The corresponding denominations of time and space are to be understood as in the preceding table.

EXAMPLE:—Convert $5^h 8^m 12^s$ into longitude.

		°	'	''
5 ^h	=	75	0	0
8 ^m	=	2	0	0
12 ^s	=		3	0
Required longitude		77	3	0

Three meridians are commonly employed by astronomers from which to reckon time: Berlin, Greenwich, and Washington.

To convert Berlin into Greenwich Time. SUBTRACT $0^h 53^m 35.5^s$, or the decimal of a day, 0.0372164 .

To convert Greenwich into Berlin Time. ADD the preceding quantities.

To convert Berlin into Washington Time. SUBTRACT $6^h 1^m 47.5^s$, or the decimal 0.2512441 .

To convert Washington into Berlin Time. ADD the preceding quantities.

To convert Greenwich into Washington Time. SUBTRACT $5^h 8^m 12.0^s$, or the decimal 0.2140277 .

To convert Washington into Greenwich Time. ADD the preceding quantities.

V. DAYS EXPRESSED AS DECIMALS OF A YEAR.

		1	2	3	4	5	6	7	8	9
		·0027	·0054	·0082	·0109	·0137	·0164	·0191	·0219	·0246
10	·0274	·0301	·0328	·0356	·0383	·0411	·0438	·0465	·0493	·0520
20	·0548	·0575	·0602	·0639	·0657	·0685	·0712	·0739	·0767	·0794
30	·0822	·0849	·0876	·0904	·0931	·0959	·0986	·1013	·1041	·1068
40	·1096	·1123	·1150	·1178	·1205	·1233	·1260	·1287	·1315	·1342
50	·1370	·1397	·1424	·1452	·1479	·1506	·1534	·1561	·1589	·1616
60	·1644	·1671	·1698	·1726	·1753	·1781	·1808	·1835	·1863	·1890
70	·1918	·1945	·1972	·2000	·2027	·2054	·2082	·2109	·2137	·2164
80	·2192	·2219	·2246	·2274	·2301	·2329	·2356	·2383	·2411	·2438
90	·2466	·2493	·2520	·2548	·2575	·2603	·2630	·2657	·2687	·2712
100	·2740	·2767	·2794	·2822	·2849	·2876	·2904	·2931	·2959	·2986
110	·3013	·3041	·3068	·3096	·3123	·3150	·3178	·3205	·3233	·3260
120	·3287	·3315	·3342	·3370	·3397	·3424	·3452	·3479	·3507	·3534
130	·3561	·3589	·3616	·3644	·3671	·3698	·3726	·3753	·3781	·3808
140	·3835	·3863	·3890	·3918	·3945	·3972	·4000	·4027	·4054	·4082
150	·4109	·4137	·4164	·4192	·4219	·4246	·4274	·4301	·4329	·4356
160	·4383	·4411	·4438	·4466	·4493	·4520	·4548	·4575	·4603	·4630
170	·4657	·4685	·4712	·4740	·4767	·4794	·4822	·4849	·4877	·4904
180	·4931	·4959	·4986	·5013	·5041	·5068	·5096	·5123	·5150	·5178
190	·5205	·5233	·5260	·5287	·5315	·5342	·5370	·5397	·5424	·5452
200	·5479	·5507	·5534	·5561	·5589	·5616	·5644	·5671	·5698	·5726
210	·5753	·5781	·5808	·5835	·5863	·5890	·5918	·5945	·5972	·6000
220	·6027	·6055	·6082	·6109	·6137	·6164	·6192	·6219	·6246	·6274
230	·6301	·6329	·6356	·6383	·6411	·6438	·6466	·6493	·6520	·6548
240	·6575	·6603	·6630	·6657	·6685	·6712	·6740	·6767	·6794	·6822
250	·6850	·6877	·6904	·6931	·6959	·6986	·7013	·7041	·7068	·7096
260	·7123	·7151	·7178	·7205	·7232	·7260	·7287	·7315	·7342	·7370
270	·7397	·7424	·7452	·7479	·7507	·7534	·7561	·7589	·7616	·7644
280	·7671	·7698	·7726	·7753	·7781	·7808	·7835	·7863	·7890	·7918
290	·7945	·7972	·8000	·8027	·8055	·8082	·8109	·8137	·8164	·8192
300	·8219	·8246	·8274	·8301	·8328	·8356	·8383	·8411	·8438	·8466
310	·8493	·8520	·8548	·8575	·8603	·8630	·8657	·8685	·8712	·8740
320	·8767	·8794	·8822	·8849	·8877	·8904	·8931	·8959	·8986	·9013
330	·9041	·9068	·9096	·9123	·9150	·9178	·9205	·9233	·9260	·9287
340	·9315	·9342	·9370	·9397	·9424	·9452	·9479	·9507	·9534	·9561
350	·9589	·9616	·9644	·9671	·9698	·9726	·9753	·9781	·9808	·9835
360	·9863	·9890	·9918	·9945	·9972	1.0000				

Example 1.—What decimal of a year is 227 days? *Ans.* 0.6219.

Example 2.—What day of the year corresponds to the decimal 0.1123? *Ans.* The 41st = Feb. 10.

VI.

HOURS EXPRESSED AS DECIMAL PARTS OF A DAY.

Hours.	Decimal.
1	.0416
2	.0833
3	.1250
4	.1666
5	.2083
6	.2500
7	.2916
8	.3333
9	.3750
10	.4166
11	.4583
12	.5000
13	.5416
14	.5833
15	.6249
16	.6666
17	.7083
18	.7500
19	.7916
20	.8333
21	.8749
22	.9166
23	.9583
24	1.0000

VII.

MINUTES EXPRESSED AS DECIMAL PARTS OF A DAY.

Minutes.	Decimal.	Minutes.	Decimal.
1	.0006	31	.0215
2	.0013	32	.0222
3	.0020	33	.0229
4	.0027	34	.0236
5	.0034	35	.0243
6	.0041	36	.0250
7	.0048	37	.0256
8	.0055	38	.0263
9	.0062	39	.0270
10	.0069	40	.0277
11	.0076	41	.0284
12	.0083	42	.0291
13	.0090	43	.0298
14	.0097	44	.0305
15	.0104	45	.0312
16	.0111	46	.0319
17	.0118	47	.0326
18	.0125	48	.0333
19	.0131	49	.0340
20	.0138	50	.0347
21	.0145	51	.0354
22	.0152	52	.0361
23	.0159	53	.0368
24	.0166	54	.0375
25	.0173	55	.0381
26	.0180	56	.0388
27	.0187	57	.0395
28	.0194	58	.0402
29	.0201	59	.0409
30	.0208	60	.0416

VIII. DAYS OF THE MONTHS EXPRESSED AS DAYS
OF THE YEAR.

	5	10	15	20	25	30
January	5	10	15	20	25	30
February	35	41	46	51	56	
March	64	69	74	79	84	89
April	95	100	105	110	115	120
May	125	130	135	140	145	150
June	156	161	166	171	176	181
July	186	191	196	201	206	211
August	217	222	227	232	237	242
September	248	253	258	263	268	273
October	278	283	288	293	298	303
November	309	314	319	324	329	334
December	339	344	349	354	359	364

N.B. If the year is leap-year, an extra day must be allowed for from March 1.

The following are some illustrations of the many practical applications of the 4 preceding tables.

EXAMPLE I.

The epochs of certain astronomical observations, such as the measurements of double stars, are expressed in years and decimals of a year. Suppose that an observer at Oxford, on April 15, 1888, measured the distance of the component stars of ξ Libræ, and found it to amount to $7''$, what would be the date of that observation expressed according to the conventional method of reckoning?

The 15th of April is the 105th day of the year; but 1888 being leap-year, it was the 106th of that particular year. By Table V. the decimal part for 106 days is 0.2904; therefore the date when reduced becomes 1888.290.

EXAMPLE II.

According to the calculations of Seeling, the great comet of 1861 passed through perihelion on June 11.5508 G.M.T. What would that be, expressed in hours and minutes and seconds?

From Table VI. it appears that 0.5508 of a day corresponds to some period between 13^h and 14^h; being 0.0092^d in excess of the former.

From Table VII. it appears that 0.0092 of a day corresponds to some period between 13^m and 14^m; being 0.0002^d in excess of the former.

The difference between the decimals of 13^m and 14^m being 0.0007^d, the given quantity is $\frac{2}{7}$ of a minute, or 17.142^s in excess of the 13^m.

And the whole answer is, June 11^d 13^h 13^m 17.14^s.

EXAMPLE III.

In 1888 (leap-year) how many days intervened between Jan. 5 and Aug. 12?

From Table VIII. it appears that Aug. 10 was the 253rd day of the year; therefore Aug. 12 was the 255th, and Jan. 5 being the 5th day of the year, the tabular interval is $255 - 5 = 250$, but 1888 being leap-year, the true interval was $250 + 1$, or 251 days.

IX. FOR ASCERTAINING THE DAY OF THE WEEK CORRESPONDING TO ANY DAY OF THE MONTH IN ANY YEAR FROM 1800 TO 1900.

Years.	Months.								
1800 E.	Jan. . . .	A.	B.	C.	D.	E.	F.	G.	
1801 D.	Feb. . . .	D.	E.	F.	G.	A.	B.	C.	
1802 C.	March . .	D.	E.	F.	G.	A.	B.	C.	
1803 B.	April . .	G.	A.	B.	C.	D.	E.	F.	
1804 A. G.	May . . .	B.	C.	D.	E.	F.	G.	A.	
1805 F.	June. . .	E.	F.	G.	A.	B.	C.	D.	
1806 E.	July . . .	G.	A.	B.	C.	D.	E.	F.	
1807 D.	Aug. . .	C.	D.	E.	F.	G.	A.	B.	
1808 C. B.	Sept. . .	F.	G.	A.	B.	C.	D.	E.	
1809 A.	Oct. . . .	A.	B.	C.	D.	E.	F.	G.	
1810 G.	Nov. . . .	D.	E.	F.	G.	A.	B.	C.	
1811 F.	Dec. . . .	F.	G.	A.	B.	C.	D.	E.	
1812 E. D.									
1813 C.									
1814 B.									
1815 A.									
1816 G. F.									
1817 E.									
1818 D.									
1819 C.									
1820 B. A.									
1821 F.									
1822 G.									
1823 E.									
1824 D. C.									
1825 B.									
1826 A.									
1827 G.									
1828 F. E.									
1829 D.									
1830 C.									
1831 B.									
1832 A. G.									
1833 F.									
1834 E.									
1835 D.									
1836 C. B.									
1837 A.									
1838 G.									
1839 F. E.									
1840 E. D.									
1841 C.									
1842 B.									
1843 A.									
1844 G. F.									
1845 E.									
1846 D.									
1847 C.									
1848 B. A.									
1849 G.									
1850 F.									
1851 E.									
1852 D. C.									
1853 B.									
1854 A.									
1855 G.									
1856 F. E.									
1857 D.									
1858 C.									
1859 B.									
1860 A. G.									
	Years—	1 S	1 Sa	1 Fr	1 Th	1 W	1 Tu	1 M	
	continued	2 M	2 S	2 Sa	2 Fr	2 Th	2 W	2 Tu	
1861 F.		3 Tu	3 M	3 S	3 Sa	3 Fr	3 Th	3 W	
1862 E.		4 W	4 Tu	4 M	4 S	4 Sa	4 Fr	4 Th	
1863 D.		5 Th	5 W	5 Tu	5 M	5 S	5 Sa	5 Fr	
1864 C. B.		6 Fr	6 Th	6 W	6 Tu	6 M	6 S	6 Sa	
1865 A.		7 Sa	7 Fr	7 Th	7 W	7 Tu	7 M	7 S	
1866 G.		8 S	8 Sa	8 Fr	8 Th	8 W	8 Tu	8 M	
1868 E. D.		9 M	9 S	9 Sa	9 Fr	9 Th	9 W	9 Tu	
1869 C.		10 Tu	10 M	10 S	10 Sa	10 Fr	10 Th	10 W	
1870 B.		11 W	11 Tu	11 M	11 S	11 Sa	11 Fr	11 Th	
1871 A.		12 Th	12 W	12 Tu	12 M	12 S	12 Sa	12 Fr	
1872 G. F.		13 Fr	13 Th	13 W	13 Tu	13 M	13 S	13 Sa	
1873 E.		14 Sa	14 Fr	14 Th	14 W	14 Tu	14 M	14 S	
1874 D.		15 S	15 Sa	15 Fr	15 Th	15 W	15 Tu	15 M	
1875 C. A.		16 M	16 S	16 Sa	16 Fr	16 Th	16 W	16 Tu	
1876 B. A.		17 Tu	17 M	17 S	17 Sa	17 Fr	17 Th	17 W	
1877 G.		18 W	18 Tu	18 M	18 S	18 Sa	18 Fr	18 Th	
1878 F. E.		19 Th	19 W	19 Tu	19 M	19 S	19 Sa	19 Fr	
1879 E.		20 Fr	20 Th	20 W	20 Tu	20 M	20 S	20 Sa	
1880 D. C.		21 Sa	21 Fr	21 Th	21 W	21 Tu	21 M	21 S	
1881 B.		22 S	22 Sa	22 Fr	22 Th	22 W	22 Tu	22 M	
1882 A.		23 M	23 S	23 Sa	23 Fr	23 Th	23 W	23 Tu	
1883 G.		24 Tu	24 M	24 S	24 Sa	24 Fr	24 Th	24 W	
1884 F. E.		25 W	25 Tu	25 M	25 S	25 Sa	25 Fr	25 Th	
1885 D.		26 Th	26 W	26 Tu	26 M	26 S	26 Sa	26 Fr	
1886 C.		27 Fr	27 Th	27 W	27 Tu	27 M	27 S	27 Sa	
1887 B. A.		28 S	28 Fr	28 Th	28 W	28 Tu	28 M	28 S	
1888 A. G.		29 S	29 Sa	29 Fr	29 Th	29 W	29 Tu	29 M	
1889 F.		30 M	30 S	30 Sa	30 Fr	30 Th	30 W	30 Tu	
1890 G. F.		31 Tu	31 M	31 S	31 Sa	31 Fr	31 Th	31 W	

The foregoing table is useful for verifying dates (past or future) by inspection ^a.

To ascertain the day of the week corresponding to a certain day of the month in a certain year, look in the Table of *Years* for the given year, opposite which will be found the Dominical Letter; then look in the Table of *Months*, opposite the given month for the same letter, and underneath the column containing it will be found the Calendar for that month in the given year. When the Calendar for the month is found, any day of the week or month can easily be traced.

It will be observed that there are two letters opposite the Leap Years. The first letter is used for January and February, the second for the other months.

EXAMPLE I.

The Battle of Waterloo was fought on June 18, 1815; what day of the week was that?

In the column in Table IX. containing the year 1815 the index (or Dominical) letter belonging to the year is A: then on referring to column 2, opposite June, the letter A will be found in the 4th column, in the lower part of which it will be seen that the 18th day is a Sunday. So the Battle of Waterloo was fought on a Sunday ^b.

EXAMPLE II.

The Battle of Trafalgar was fought on Oct. 21, 1805; what day of the week was that?

In the column in Table IX. containing the year 1805 the index (or Dominical) letter belonging to the year is F: then on referring to column 2, opposite October, the letter F will be found in the 6th column: in the lower part of which it will be seen that the 21st day is Monday. So the Battle of Trafalgar was fought on a Monday.

The following old couplet, committed to memory, affords an easy rule for ascertaining without reference to an almanack on what day of the week any day of a month will fall:—

“At Dover Dwells George Brown, Esquire,
Good Christian Friend, and David Friar.”

Explanation.—The couplet contains 12 words, one for each month in order, beginning with January. The initial letter of each word corresponds with the letter in the Prayer Book Calendar for the 1st of the month represented by the word. The key to the use of the rule is the knowledge of the Sunday letter for the year, which for 1890 is E.

EXAMPLE I.

On what day of the week will March 16 fall in 1890?

D, the first letter of “Dwells,” stands for March 1. But D is the letter or day before E—that is, D, the 1st of March, was a Saturday. The calculation is instantaneous that March 16 is the third Sunday in the month.

EXAMPLE II.

On what day in the week will December 3 fall in 1890?

F is December 1. But F is the day after E—*i. e.*, Monday; therefore December 3 will be on a Wednesday ^c.

^a Another and perhaps more simple perpetual Calendar is given in Dallet's *Merveilles du Ciel*, Paris 1888, p. 173.

^b A writer in the *New York Times* of April 10, 1862, showed that in regard to battles fought on Sunday, the defeated side almost always was the one which began the conflict: in other words, the one which caused the desecration of the

holy day. Waterloo is a case in point.

^c This couplet and explanation appeared in the *Times* of September 11, 1879, in a letter signed “T. B. Paget.” The writer adds:—“So many of my friends have asked for a copy of this ready-reckoner that perhaps its proved utility may induce you to publish it for general information.”

X. MEAN REFRACTION OF CELESTIAL OBJECTS FOR TEMPERATURE 50° AND PRESSURE 29.6 INCHES.

Alt.	Refr.	Alt.	Refr.	Alt.	Refr.	Alt.	Refr.	Alt.	Refr.
° ' "	' "	° ' "	' "	° ' "	' "	° ' "	' "	° ' "	' "
0 0	33 0	2 45	15 27	5 30	9 8	8 15	6 18	12 0	4 23
5	32 10	50	15 9	35	9 1	20	6 15	10	4 20
10	31 22	55	14 52	40	8 54	25	6 11	20	4 16
15	30 36	3 0	14 36	45	8 47	30	6 8	30	4 13
20	29 50	5	14 20	50	8 41	35	6 5	40	4 9
25	29 6	10	14 4	55	8 34	40	6 1	50	4 6
30	28 23	15	13 39	6 0	8 28	45	5 58	13 0	4 3
35	27 41	20	13 34	5	8 21	50	5 55	10	4 0
40	27 0	25	13 20	10	8 15	55	5 52	20	3 57
45	26 20	30	13 6	15	8 9	9 0	5 48	30	3 54
50	25 42	35	12 53	20	8 3	5	5 45	40	3 51
55	25 5	40	12 40	25	7 57	10	5 42	50	3 48
1 0	24 29	45	12 27	30	7 51	15	5 39	14 0	3 45
5	23 54	50	12 15	35	7 45	20	5 36	10	3 43
10	23 20	55	12 3	40	7 40	25	5 34	20	3 40
15	22 47	4 0	11 51	45	7 35	30	5 31	30	3 38
20	22 15	5	11 40	50	7 30	35	5 28	40	3 35
25	21 44	10	11 29	55	7 25	40	5 25	50	3 33
30	21 15	15	11 18	7 0	7 20	45	5 23	15 0	3 30
35	20 46	20	11 8	5	7 15	50	5 20	10	3 28
40	20 18	25	10 58	10	7 11	55	5 18	20	3 26
45	19 51	30	10 48	15	7 6	10 0	5 15	30	3 24
50	19 25	35	10 39	20	7 2	10	5 10	40	3 21
55	19 0	40	10 29	25	6 57	20	5 5	50	3 19
2 0	18 35	45	10 20	30	6 53	30	5 0	16 0	3 17
5	18 11	50	10 11	35	6 49	40	4 56	10	3 15
10	17 48	55	10 2	40	6 45	50	4 51	20	3 12
15	17 26	5 0	9 54	45	6 41	11 0	4 47	30	3 10
20	17 4	5	9 46	50	6 37	10	4 43	40	3 8
25	16 44	10	9 38	55	6 33	20	4 39	50	3 6
30	16 24	15	9 30	8 0	6 29	30	4 34	17 0	3 4
35	16 4	20	9 23	5	6 25	40	4 31	10	3 3
40	15 45	25	9 15	10	6 22	50	4 27	20	3 1

Alt.	Refr.	Alt.	Refr.	Alt.	Refr.	Alt.	Refr.	Alt.	Refr.
17 30	2 59	22 50	2 15	28 45	I 44	41 0	I 5	60 0	0 33
40	2 57	23 0	2 14	29 0	I 42	30	I 4	61 0	0 32
50	2 55	10	2 13	20	I 41	42 0	I 3	62 0	0 30
18 0	2 54	20	2 12	40	I 40	30	I 2	63 0	0 29
10	2 52	30	2 11	30 0	I 38	43 0	I 1	64 0	0 28
20	2 51	40	2 10	20	I 37	30	I 0	65 0	0 26
30	2 49	50	2 9	40	I 36	44 0	0 59	66 0	0 25
40	2 47	24 0	2 8	31 0	I 35	30	0 58	67 0	0 24
50	2 46	10	2 7	20	I 33	45 0	0 57	68 0	0 23
19 0	2 44	20	2 6	40	I 32	30	0 56	69 0	0 22
10	2 43	30	2 5	32 0	I 31	46 0	0 55	70 0	0 21
20	2 41	40	2 4	20	I 30	30	0 54	71 0	0 19
30	2 40	50	2 3	40	I 29	47 0	0 53	72 0	0 18
40	2 38	25 0	2 2	33 0	I 28	30	0 52	73 0	0 17
50	2 37	10	2 1	20	I 26	48 0	0 51	74 0	0 16
20 0	2 35	20	2 0	40	I 25	30	0 50	75 0	0 15
10	2 34	30	I 59	34 0	I 24	49 0	0 49	76 0	0 14
20	2 32	40	I 58	20	I 23	30	0 49	77 0	0 13
30	2 31	50	I 57	40	I 22	50 0	0 48	78 0	0 12
40	2 29	26 0	I 56	35 0	I 21	30	0 47	79 0	0 11
50	2 28	10	I 55	20	I 20	51 0	0 46	80 0	0 10
21 0	2 27	20	I 55	40	I 19	30	0 45	81 0	0 9
10	2 26	30	I 54	36 0	I 18	52 0	0 44	82 0	0 8
20	2 25	40	I 53	30	I 17	30	0 44	83 0	0 7
30	2 24	50	I 52	37 0	I 16	53 0	0 43	84 0	0 6
40	2 23	27 0	I 51	30	I 14	30	0 42	85 0	0 5
50	2 21	15	I 50	38 0	I 13	54 0	0 41	86 0	0 4
22 0	2 20	30	I 49	30	I 11	55 0	0 40	87 0	0 3
10	2 19	45	I 48	39 0	I 10	56 0	0 38	88 0	0 2
20	2 18	28 0	I 47	30	I 9	57 0	0 37	89 0	0 1
30	2 17	15	I 46	40 0	I 8	58 0	0 35	90 0	0 0
40	2 16	30	I 45	30	I 7	59 0	0 34		

XI. CORRECTION OF

Ap. Alt.	Height of the Thermometer.							
	20°	24°	28°	32°	36°	40°	44°	48°
° ' "	' +"	' +"	' +"	' +"	' +"	+"	+"	+"
0 0	2 40	2 18	1 55	1 33	1 11	51	31	10
0 10	2 32	2 12	1 49	1 28	1 8	48	29	10
0 20	2 25	2 5	1 44	1 24	1 4	46	28	9
0 30	2 18	1 59	1 39	1 20	1 1	44	26	9
0 40	2 11	1 53	1 34	1 16	58	42	25	8
0 50	2 5	1 48	1 29	1 12	55	40	24	8
1 0	1 59	1 43	1 25	1 9	53	38	23	8
1 10	1 53	1 38	1 21	1 6	50	36	22	7
1 20	1 48	1 33	1 17	1 3	48	34	21	7
1 30	1 43	1 29	1 14	1 0	46	32	20	7
1 40	1 39	1 25	1 11	57	44	31	18	6
1 50	1 35	1 21	1 8	55	42	30	17	6
2 0	1 31	1 18	1 5	53	39	29	17	6
2 20	1 23	1 11	1 0	48	37	26	16	5
2 40	1 17	1 6	55	44	34	24	14	5
3 0	1 11	1 1	51	41	32	22	13	4
3 20	1 6	57	47	38	29	21	13	4
3 40	1 2	53	44	36	28	20	12	4
4 0	58	49	41	33	26	18	11	4
4 30	53	45	38	31	24	17	10	3
5 0	48	41	35	28	22	16	9	3
5 30	45	38	32	26	20	14	9	3
6 0	41	35	30	24	19	13	8	3
6 30	38	33	28	22	17	12	7	2
7 0	36	31	26	21	16	12	7	2
8 0	32	27	23	19	15	10	6	2
9 0	28	24	20	16	13	9	5	2
10 0	26	22	18	15	12	8	5	2
11 0	23	20	17	14	11	8	5	2

MEAN REFRACTION.

Height of the Thermometer.								Ap. Alt.
52°	56°	60°	64°	68°	72°	76°	80°	° ' "
—	—	—	' —	' —	' —	' —	' —	° ' "
10	29	48	1 7	1 25	1 43	2 1	2 19	0 0
9	27	45	1 4	1 21	1 38	1 54	2 12	0 10
9	26	44	1 1	1 17	1 33	1 49	2 5	0 20
8	25	41	58	1 13	1 28	1 43	1 59	0 30
8	24	39	55	1 10	1 24	1 38	1 53	0 40
8	23	37	52	1 6	1 20	1 34	1 48	0 50
7	21	36	50	1 3	1 17	1 30	1 43	1 0
7	20	34	48	1 0	1 13	1 26	1 38	1 10
6	19	32	45	57	1 9	1 21	1 33	1 20
6	18	31	43	54	1 6	1 18	1 29	1 30
6	18	30	41	52	1 4	1 15	1 25	1 40
6	17	28	39	50	1 1	1 11	1 21	1 50
5	16	27	37	48	58	1 8	1 18	2 0
5	15	25	35	44	54	1 3	1 11	2 20
5	14	23	32	41	50	58	1 6	2 40
4	13	21	30	38	46	54	1 1	3 0
4	12	20	28	35	43	50	0 57	3 20
4	11	18	26	33	40	47	53	3 40
4	10	17	24	31	37	44	50	4 0
3	9	16	22	28	34	40	45	4 30
3	9	14	20	26	31	36	40	5 0
3	8	13	19	24	29	34	38	5 30
2	7	12	17	22	26	31	35	6 0
2	7	11	15	20	24	29	33	6 30
2	6	10	14	19	23	27	31	7 0
2	5	9	13	16	20	24	27	8 0
2	5	8	11	14	18	21	24	9 0
1	4	7	10	13	16	19	22	10 0
1	4	7	9	12	15	18	20	11 0

CORRECTION OF

Ap. Alt.	Height of the Thermometer.							
	20° + '	24° + "	28° + "	32° + "	36° + "	40° + "	44° + "	48° + "
12	21	18	15	13	10	7	4	1
13	20	17	14	12	9	7	4	1
14	18	16	13	11	8	6	4	1
15	17	15	12	10	8	6	3	1
16	16	14	12	9	7	5	3	1
17	15	13	11	9	7	5	3	1
18	14	12	10	8	6	5	3	1
19	13	11	9	8	6	4	3	1
20	13	11	9	7	6	4	2	1
25	10	8	7	6	5	3	2	1
30	8	7	6	5	4	3	2	1
35	7	6	5	4	3	2	1	0
40	6	5	4	3	3	2	1	0
45	5	4	3	3	2	2	1	0
50	4	3	3	2	2	1	1	0
55	3	3	2	2	2	1	1	0
60	3	2	2	2	1	1	1	0
65	2	2	2	1	1	1	0	0
70	2	1	1	1	1	1	0	0
80	1	1	1	0	0	0	0	0
90	0	0	0	0	0	0	0	0
Height of Barometer.				— 28.26	— 28.56	— 28.85	— 29.15	— 29.45

MEAN REFRACTION (*Continued*).

Height of the Thermometer.								Ap. Alt.
52°	56°	60°	64°	68°	72°	76°	80°	°
—"	—"	—"	—"	—"	—"	—"	—"	
I	4	6	9	11	13	16	18	12
I	3	6	8	10	12	15	17	13
I	3	5	7	9	11	14	16	14
I	3	5	7	9	11	13	15	15
I	3	5	6	8	10	12	14	16
I	3	4	6	8	9	11	13	17
I	2	4	6	7	9	10	12	18
I	2	4	5	7	8	10	11	19
I	2	4	5	6	8	9	11	20
I	2	3	4	5	6	7	8	25
0	I	2	3	4	5	6	7	30
0	I	2	3	3	4	5	6	35
0	I	2	2	3	3	4	5	40
0	I	I	2	2	3	3	4	45
0	I	I	2	2	2	3	3	50
0	I	I	I	2	2	2	3	55
0	0	I	I	I	2	2	2	60
0	0	I	I	I	I	2	2	65
0	0	0	I	I	I	I	I	70
0	0	0	0	0	I	I	I	80
0	0	0	0	0	0	0	0	90
+	+	+	+	+	Height of Barometer.			
29.75	30.05	30.35	30.64	30.93				

In practical astronomy few tables are more constantly called into requisition than those relating to refraction: in fact, this correction may be regarded as the most important of those which have to be applied to instrumental readings.

EXAMPLE I.

What is the correction for refraction for an altitude of $8^{\circ} 5'$, the thermometer standing at 50.0° and the barometer at 29.6 inches?

Answer (by inspection) $6' 25''$:

and therefore,

Apparent altitude	=	$8^{\circ} 5'$
Refraction	=	$- 6 25''$
					$7 58 35$
True altitude	$7 58 35$

EXAMPLE II.

What is the correction for refraction for the same altitude, the thermometer standing at 44° and the barometer at 29.45 inches?

Thermometer correction for altitude $8^{\circ} 5'$	=				$+ 0 6$
Barometer ditto	=				$- 0 2$
					$+ 0 4$
Correction for both is	=				$+ 0 4$
Mean refraction	=				$- 6 25$
					$- 6 21$
∴ True refraction	=				$- 6 21$
					$0 1 ''$
Apparent altitude	=				$8 5 0$
True refraction	=				$- 6 21$
					$7 58 39$
True altitude	$7 58 39$

XII. ANNUAL PRECESSION.

It frequently happens that the amateur astronomer wants to ascertain quickly and easily (even if only approximately) the Right Ascension and Declination of a star for an epoch different from that of the book or catalogue which he is using. Very often the catalogue itself does not contain the amounts of precession in Right Ascension and Declination to be applied to the places of the separate stars. But any change of epoch which may be desired can be effected by means of Table XII.^a, the first column of which contains, as an argument, the Right Ascension for every half-hour. The second column gives the corresponding annual precession in Declination, expressed in hundredths of a minute of arc. The remaining columns give the annual precession in Right Ascension, expressed in thousandths of a minute of time, for values of the Declination given in the headings of the respective columns. These values of the Declination are at intervals of 5° , except within 40° of the equator, where the interval employed is 10° . Negative quantities are indicated, in the body of the Table, by the use of *Italic type*.

^a From *Harvard Photometry*, p. 319.

R.A.	Prec. in Dec.	85°	80°	75°	70°	65°	60°	55°	50°	40°	30°	20°	10°	0°	-10°	-20°	-30°
h. m.	'	n.	m.	m.	m.	m.	m.	m.	m.	m.	m.	m.	m.	m.	m.	m.	m.
0	0	.33	.051	.051	.051	.051	.051	.051	.051	.051	.051	.051	.051	.051	.051	.051	.051
	30	.33	.084	.067	.062	.059	.057	.056	.055	.055	.053	.053	.052	.052	.051	.050	.050
1	0	.32	.117	.084	.073	.067	.063	.061	.059	.058	.056	.054	.053	.052	.051	.050	.049
	30	.31	.148	.099	.083	.075	.069	.066	.063	.061	.058	.056	.054	.053	.051	.049	.048
2	0	.29	.178	.114	.093	.082	.075	.070	.067	.064	.060	.057	.055	.053	.051	.049	.047
	30	.27	.206	.128	.102	.087	.080	.075	.070	.067	.063	.059	.056	.054	.051	.048	.046
3	0	.24	.231	.140	.109	.094	.085	.078	.073	.070	.064	.060	.057	.054	.051	.048	.045
	30	.20	.253	.151	.117	.100	.089	.082	.076	.072	.066	.061	.058	.054	.051	.048	.044
4	0	.17	.272	.161	.123	.104	.092	.084	.079	.074	.067	.062	.058	.055	.051	.047	.044
	30	.13	.286	.168	.128	.107	.095	.087	.080	.076	.068	.063	.059	.055	.051	.047	.043
5	0	.09	.297	.173	.131	.110	.097	.088	.082	.077	.069	.063	.059	.055	.051	.047	.043
	30	.04	.304	.176	.133	.112	.098	.089	.083	.077	.070	.064	.059	.055	.051	.047	.043
6	0	.00	.306	.177	.134	.112	.099	.090	.083	.078	.070	.064	.059	.055	.051	.047	.043
	30	.04	.304	.176	.133	.112	.098	.089	.083	.077	.070	.064	.059	.055	.051	.047	.043
7	0	.09	.297	.173	.131	.110	.097	.088	.082	.077	.069	.063	.059	.055	.051	.047	.043
	30	.13	.286	.168	.128	.107	.095	.087	.080	.076	.068	.063	.059	.055	.051	.047	.043
8	0	.17	.272	.161	.123	.104	.092	.084	.079	.074	.067	.062	.058	.055	.051	.047	.044
	30	.20	.253	.151	.117	.100	.089	.082	.076	.072	.066	.061	.058	.054	.051	.048	.044
9	0	.24	.231	.140	.109	.094	.085	.078	.073	.070	.064	.060	.057	.054	.051	.048	.045
	30	.27	.206	.128	.102	.087	.080	.075	.070	.067	.063	.059	.056	.054	.051	.048	.046
10	0	.29	.178	.114	.093	.082	.075	.070	.067	.064	.060	.057	.055	.053	.051	.049	.047
	30	.31	.148	.099	.083	.075	.069	.066	.063	.061	.058	.056	.054	.053	.051	.049	.048
11	0	.32	.117	.084	.073	.067	.063	.061	.059	.058	.056	.054	.053	.052	.051	.050	.049
	30	.33	.084	.067	.062	.059	.057	.056	.055	.055	.053	.053	.052	.052	.051	.050	.049
12	0	.33	.051	.051	.051	.051	.051	.051	.051	.051	.051	.051	.051	.051	.051	.051	.051
	30	.33	.018	.035	.040	.043	.045	.046	.047	.047	.049	.049	.050	.050	.051	.052	.053
13	0	.32	.015	.018	.029	.035	.039	.041	.043	.044	.046	.048	.049	.050	.051	.052	.053
	30	.31	.046	.003	.019	.027	.033	.036	.039	.041	.044	.046	.048	.049	.051	.053	.054
14	0	.29	.076	.012	.009	.020	.027	.032	.035	.038	.042	.045	.047	.049	.051	.053	.055
	30	.27	.104	.026	.000	.015	.022	.027	.032	.035	.039	.043	.046	.048	.051	.054	.056
15	0	.24	.129	.038	.007	.008	.017	.024	.029	.032	.038	.042	.045	.048	.051	.054	.057
	30	.20	.151	.049	.015	.002	.013	.020	.026	.030	.036	.041	.044	.048	.051	.054	.058
16	0	.17	.170	.059	.021	.002	.010	.018	.023	.028	.035	.040	.044	.047	.051	.055	.058
	30	.13	.184	.066	.026	.005	.007	.015	.022	.026	.034	.039	.043	.047	.051	.055	.059
17	0	.09	.195	.071	.029	.008	.005	.014	.020	.025	.033	.039	.043	.047	.051	.055	.059
	30	.04	.202	.074	.031	.010	.004	.013	.019	.025	.032	.038	.043	.047	.051	.055	.059
18	0	.00	.204	.075	.032	.010	.003	.012	.019	.024	.032	.038	.043	.047	.051	.055	.059
	30	.04	.202	.074	.031	.010	.004	.013	.019	.025	.032	.038	.043	.047	.051	.055	.059
19	0	.09	.195	.071	.029	.008	.005	.014	.020	.025	.033	.039	.043	.047	.051	.055	.059
	30	.13	.184	.066	.026	.005	.007	.015	.022	.026	.034	.039	.043	.047	.051	.055	.059
20	0	.17	.170	.059	.021	.002	.010	.018	.023	.028	.035	.040	.044	.047	.051	.055	.058
	30	.20	.151	.049	.015	.002	.013	.020	.026	.030	.036	.041	.044	.048	.051	.054	.058
21	0	.24	.129	.038	.007	.008	.017	.024	.029	.032	.038	.042	.045	.048	.051	.054	.057
	30	.27	.104	.026	.000	.015	.022	.027	.032	.035	.039	.043	.046	.048	.051	.054	.056
22	0	.29	.076	.012	.009	.020	.027	.032	.035	.038	.042	.045	.047	.049	.051	.053	.055
	30	.31	.046	.003	.019	.027	.033	.036	.039	.041	.044	.046	.048	.049	.051	.053	.054
23	0	.32	.015	.018	.029	.035	.039	.041	.043	.044	.046	.048	.049	.050	.051	.052	.053
	30	.33	.018	.035	.040	.043	.045	.046	.047	.049	.049	.049	.050	.050	.051	.052	.053

APPROXIMATE ANNUAL VALUE OF PRECESSION
IN RIGHT ASCENSION^b.

Declination.	From 0 ^h to 6 ^h of R.A.		From 6 ^h to 12 ^h of R.A.		From 12 ^h to 18 ^h of R.A.		From 18 ^h to 25 ^h of R.A.	
	s	s	s	s	s	s	s	s
20° S	3.1	decreasing to 2.6	2.6	incr. to 3.1	3.1	incr. to 3.6	3.6	decr. to 3.1
Equator	3.1		3.1		3.1		3.1	
20° N	3.1	increasing to 3.6	3.6	decr. to 3.1	3.1	decr. to 2.6	2.6	incr. to 3.1
40° N	3.1	„ 4.2	4.2	„ 3.1	3.1	„ 1.9	1.9	„ 3.1
50° N	3.1	„ 4.7	4.7	„ 3.1	3.1	„ 1.5	1.5	„ 3.1
60° N	3.1	„ 5.4	5.4	„ 3.1	3.1	„ 0.8	0.8	„ 3.1

The Precession in R.A. is always to be applied additively except in the case of a few stars very near the poles of the Ecliptic.

APPROXIMATE ANNUAL VALUE OF PRECESSION
IN NORTH DECLINATION^b.

R.A.				Annual Precession.	R.A.				Annual Precession.
h. m.		and	h. m.	„	h. m.		and	h. m.	„
0	0		24	+ 20.0	12	0		12	- 20.0
1	0	„	23	19.4	13	0	„	11	19.4
2	0	„	22	17.4	14	0	„	10	17.4
2	30	„	22	15.9	14	30	„	9	15.9
3	0	„	21	1.2	15	0	„	9	14.2
3	30	„	20	12.2	15	30	„	8	12.2
4	0	„	20	10.0	16	0	„	8	10.0
4	30	„	19	7.7	16	30	„	7	7.7
5	0	„	19	5.2	17	0	„	7	5.2
5	30	„	18	2.6	17	30	„	6	2.6
6	0	„	18	0.0	18	0	„	6	0.0

In the case of stars with *South* Declination the above amounts are applied in reverse order, + becoming -, and - becoming +.

^b From L. Clark and H. Sadler's *Star Guide*, p. xv.



VOCABULARY OF DEFINITIONS, &c.

. In making use of this, the General Indexes to each volume must be consulted at the same time, for many things are defined in the Text of this work, to allude again to which here would be a vain repetition. Of the Arabic names of the Stars a limited number only are given, and even many of these have virtually fallen into disuse.

A.

Abbreviations often used by Astronomers :

Alt. Altitude.
 A.M. *Ante Meridiem*.
 B.A.C. British Association Catalogue.
 B.M.T. Berlin Mean Time.
Cat. Catalogue.
 Decl. Declination.
 Deg. Degree.
 Diam. Diameter.
 Diff. Difference.
 Dist. Distance.
 Ep. Epoch.
 HJ. Sir W. Herschel.
 G.M.T. Greenwich Mean Time.
 Groom. Groombridge's Catalogue of Stars.
 h. Hour.
 h. Sir J. Herschel.
 Mag. Magnitude of Star.
 M. Messier's Catalogue of Nebulæ.
 M.T. Mean Time.
 m. Minute of Time.
 N.P.D. North Polar Distance.
 nf. North and following.
 np. North and preceding.
 N.S. New Style.
 O.S. Old Style.
 P.M. *Post Meridiem*.
 Pos. Angle of Position.
 s. Second of Time.
 Σ. W. Struve's Catalogue of Double Stars, or Struve himself.
 sf. South and following.
 Sm. Admiral W. H. Smyth.
 sp. South and preceding.
Aberation, (*aberrare*, to wander from).
Achernar, a star otherwise called α Eridani.
Achromatic (α without, and $\chi\rho\omega\mu\alpha$ colour).
 A refracting telescope is said to be

achromatic when the lenses are so combined that an image practically destitute of colour is obtained.
Acolyte ($\acute{\alpha}\kappa\acute{\omicron}\lambda\omicron\upsilon\theta\omicron\varsigma$, an attendant); a term sometimes used to designate the smaller of two stars placed in close contiguity.
Acronical ($\acute{\alpha}\kappa\rho\acute{\omicron}\nu\chi\omicron\varsigma$, at nightfall). A heavenly body is said to rise or set acronically when it rises or sets at sunset.
Acubene, a star otherwise known as α Cancri.
Adara, a star otherwise called ϵ Canis Majoris.
Adjustment (*ad* to, and *justus* just); the operation of bringing all the parts of an instrument into their proper relative position for use.
Ærolite ($\acute{\alpha}\eta\rho$ the air, $\lambda\acute{\iota}\theta\omicron\varsigma$ a stone).
Æstival (*æstas*, summer), relating to the summer.
Albedo of a planet: "The relative capacity for reflection of diffused light from equal areas." (*Month. Not.* R.A.S., vol. xlviii. p. 35.)
Albireo, a star otherwise called β Cygni.
Alchiba, a star otherwise called α Corvi.
Alcor, a star otherwise known as ρ Ursæ Majoris.
Alcyone, a star in the Pleiades, otherwise called η Tauri.
Aldebaran, a star otherwise called α Tauri.
Alderamin, a star otherwise called α Cephei.
Algeiba, a star otherwise called γ^1 Leonis.
Algenib, a star otherwise called γ Pegasi. The star α Persei sometimes bore this name.
Algol, a well-known variable star, otherwise called β Persei.
Algorab, a star otherwise called α Corvi.

Athena, a star otherwise called γ Geminorum.

Alidad; the cross-bar carrying the verniers of a graduated circle. The word, which is not often met with, is of Arabic origin, and was formerly applied to the moveable index of an astrolabe.

Alioth, a star otherwise called ϵ Ursæ Majoris.

Alkaid, a star otherwise called η Ursæ Majoris.

Alkes, a star otherwise known as a Crateris.

Almaac, a star otherwise called γ Andromedæ.

Almucantar, an equal altitude instrument based on the principle of flotation and intended to be used as a substitute for the Transit Instrument.

Almucantars, a name for circles of altitude parallel to the horizon.

Almucantar Staff, an instrument formerly used for determining the amplitude of an object.

Alnilam, a star otherwise called ϵ Orionis.

Alphard, a star otherwise called α Hydræ.

Alphecca, a star otherwise called α Coronæ Borealis.

Alpheratz, a star otherwise called α Andromedæ.

Alphirk, a star otherwise called β Cephei.

Alshain, a star otherwise called β Aquilæ.

Altair, a star otherwise called α Aquilæ.

Altazimuth Instrument. See vol. ii. p. 149.

Altitude (*altitude*, height); the angular elevation of a heavenly body above the horizon measured towards the zenith on any great circle.

Alwaid, a star otherwise called β Draconis.

Amplitude (*amplitudo*, extent); the angular distance of a heavenly body from the East or West point of the horizon, measured on the horizon.

Analemma, a scale painted on globes, and having reference to the motion of the Sun.

Angle (*angulus*, a corner); the inclination of two straight lines to each other in the same plane gives rise to a *plane rectilineal angle*, or simply an *angle*. When a straight line, standing on another straight line, makes the adjacent angles equal to each other, each of those angles is called a *right angle*; but if the adjacent angles are not equal to each other, then the greater is called an *obtuse* and the lesser an *acute* angle.

Angle of eccentricity. See vol. i. pp. 58, 61, 403.

Angle of position (chiefly used with reference to double stars). This is the

angle formed by a line joining two stars with the meridian line which passes through the larger one. It is reckoned from 0° to 360° from the North point of the field of the telescope, by East, South, and West, round to North again.

Angle of situation; a term introduced by Sir J. Herschel to indicate the angle formed at any star by arcs passing through the zenith and the Pole respectively. This angle, sometimes called the parallax angle, was formerly known as the "angle of position," but it has been thought best to limit this term as above.

Angular velocity of any heavenly body is the rate of increase or decrease of the angle contained between the radius vector of the body and a fixed straight line.

Annual equation. See vol. i. p. 121.

Annual Variation in the Right Ascension or Declination of a star is the change produced in either element by the combined effects of precession of the equinoxes and the proper motion of the star.

Annular (*annulus*, a ring); a term applied to a certain kind of solar eclipse, because the appearance presented is a ring of light.

Anomalistic Period; the time of revolution of a planet in reference to its line of *apsides* (q. v.) In the case of the Earth, the period is called the *anomalistic year*; in the case of the Moon, the *anomalistic month*.

Anomaly (*a not*, and *μαλός* even), *Eccentric*. "An auxiliary angle employed to abridge the calculations connected with the motion of a planet or comet in an elliptic orbit. If a circle be drawn, having its centre coincident with that of the ellipse, and a diameter equal to the transverse [major] axis of the latter, and if from this axis a perpendicular be drawn through the true place of the body in the ellipse to meet the circumference of the circle, then the eccentric anomaly will be the angle formed by a line drawn from the point where the perpendicular meets the circle, to the centre, with the longer diameter of the ellipse."—*Hind*.

Anomaly, Mean; the angular distance of a planet or comet from the perihelion or aphelion, supposing it to have moved with its *mean* velocity.

Anomaly, True; the *true* angular distance of a comet or planet from perihelion or aphelion.

Ansa (*ansa*, a handle); a term applied

- to those opposite extremities of the ring of Saturn which, viewed foreshortened from the Earth, appear as projections or handles to the "Ball."
- Antares* (*ἀντί* opposed to, *Ἄρης*, Mars, *i.e.* rivalling Mars), a red star, otherwise called a *Scorpii*.
- Antipodes* (*ἀντί* opposite, and *πόδες* feet); those inhabitants of the Earth who live under opposite meridians and opposite parallels of latitude, who walk therefore *feet to feet*.
- Aperture* (*apertus*, uncovered); that portion of the object-glass (or mirror, as the case may be) of a telescope which is actually available for the scrutiny of an object. It is usually expressed in the form of the linear measure of the diameter.
- Aphelion* (*ἀπό* from, *ἥλιος* the Sun); that point in the orbit of a planet or comet farthest from the Sun.
- Aplanatic* (*a* without, and *πλάνη* error); free from error. The term is in strictness applicable to any optical instrument in which the spherical and chromatic aberrations are duly corrected.
- Apoee* (*ἀπό* from, *γῆ* the Earth); the correlative of aphelion, applied in two general senses, (1) to that point of the Moon's orbit farthest from the Earth; (2) to that point of the Earth's orbit farthest from the Sun.
- Apo-Saturnium*; the point in the orbit of a satellite of Saturn most remote from the primary.
- Apparent* (*apparere*, to appear at); employed astronomically as the opposite to "true" or "real." Thus, the apparent sunset differs from the real sunset in consequence of the effect of refraction. The apparent equinox differs from the real equinox in consequence of the effect of nutation. The apparent position of a star differs from the real position in consequence of the effect of refraction, aberration, nutation, &c.
- Apparition, Circle of perpetual*; a circle of Declination which separates the portion of the heavens which at a particular latitude does not go below the horizon from that which does.
- Appulse* (*appellere*, to drive towards); the near approach of two heavenly bodies.
- Apsis* (*ἀψίς*, an arch); applied to the opposite extremities of a planetary or cometary orbit, which are also its points of perihelion and aphelion. So the *Line of Apsides* is the line joining these two points, which is also the major-axis of the ellipse.
- Arc* (*arcus*, a bow); a part of any curved surface.
- Arc, diurnal*; that part of a circle parallel to the equator which is apparently described by the Sun between sunrise and sunset.
- Arc, nocturnal*; the converse of the preceding.
- Arc of progression*; the arc of the ecliptic described by a planet when moving in the order of the signs, or from West to East.
- Arc of retrogradation*; the converse of the preceding.
- Arctophylax* (*ἄρκτος* a bear, and *φύλαξ* a keeper); the "Bear-keeper"—an ancient name for the constellation Boötes.
- Arcturus* (*ἄρκτος* a bear, and *οὐρος* a watcher), a star, otherwise called a Boötis. [See preceding paragraph.]
- Argument* (*argumentum*, a thing taken for granted) is a term used to denote any mathematical quantity on which another depends or by which another may be found.
- Ariled*, a star otherwise known as a Cygni.
- Aries, First Point of*; the origin or station from which are reckoned Right Ascensions on the equator and longitudes on the ecliptic.
- Armillary Sphere* (*armilla*, a bracelet); an instrument made up of a number of circles of metal crossing one another and representing the various imaginary circles of geographers and astronomers. It was thought to be useful for assisting students in realising dispositions and motions of the heavenly bodies.
- Arneb*, a star otherwise called a Leporis.
- Ascension, Oblique*. The oblique ascension is the arc of the equator between the first point of Aries and the point of the equator which rises with a heavenly body, reckoned forwards according to the order of the signs. The converse word is "descension," but it is obsolete.
- Ascension, Right*. The right ascension of a heavenly body is its distance from the first point of Aries reckoned on the equator. It is so called because in a right sphere the meridian passing through the object will coincide with the horizon when the object is rising or setting.
- Ascensional Difference* is the difference between the Right and Oblique Ascensions.
- Asterism* (*ἀστήρ*, a star); a group or collection of stars; a constellation.
- Astéroid* (*ἀστήρ* a star, and *εἶδος* a form);

star-like. A name applied to the minor planets, but now going out of use.

Astral (*ἀστήρ*, a star); anything relating to the stars.

Astrolabe (*ἀστήρ* a star, and *λαμβάνω* I take); an astronomical instrument invented by Hipparchus, designed to represent the various circles of the sphere. An old-fashioned instrument used in navigation also bore this name.

Astrology (*ἀστήρ* a star, and *λόγος* a word); identical with astronomy in grammatical meaning, but conventionally applied to the science (or delusion) of fortune-telling by aid of the stars.

Astrometry (*ἀστήρ* a star, and *μέτρον* a measure); conventionally applied to the measurement of the apparent magnitudes of stars. *Photometry* (q. v.) is used in a similar sense. Hence the words *Astrometer* and *Photometer* as names of instruments.

Astronomy (*ἀστήρ* a star, and *νόμος* a law); the science of the laws of the stars and heavenly bodies generally.

Astroscope (*ἀστήρ* a star, and *σκοπέω* I view); an instrument invented in 1698 by Shickhard of Tubingen for facilitating the study of the constellations, but now obsolete.

Augmentation of the Moon's semi-diameter is the increase due to the distance of the Moon from the observer being less than its distance from the centre of the Earth, to which calculations are referred.

Axis (*ἄξων*, an axle); an imaginary line joining the North and South poles of a planet, and upon which it is assumed to revolve.

Azimuth (*samatha* to go towards, *Arabic*); the angular distance of an object from the North or South points of the horizon, or the angle formed with the meridian by a great circle passing through the zenith and the object.

B.

Base-line, a term used in Land Surveying to indicate a line measured with great exactness, so that it may serve as the foundation (basis) of a series of triangles to connect together objects far removed from one another.

Bellatrix, a star otherwise called γ Orionis.

Benetnasch, a star otherwise called η Urse Majoris.

Betelgeuse, a star otherwise called α Orionis.

Bifid (*bi-fidus*, cleft into two parts); a

term applied to the tails of comets when they appear as if split in a longitudinal direction.

Binary (*binarius*, twofold). Two stars revolving round each other are said to form a binary system. Two stars *not* so revolving are simply said to form a "double."

Binocular (*bis* twice, and *oculus* an eye); double-eyed: a form of telescope, or any optical instrument, intended to be used with both eyes simultaneously.

Binuclear (*bis* twice, and *nucleus*). A Nebula which has two condensed portions of light is said to be "binuclear."

Bisect (*bis* twice, *secare* to cut); to divide anything into two equal parts. Astronomically the word is most usually applied to the placing of the wires of a micrometer or similar instrument centrally over an object.

Bolometer, an instrument invented by S. P. Langley to aid in the investigation of the absorption of the heat rays of the Sun.

C.

Calendar, or *kalendar* (*kalendā*, the first day of each month), is the name applied to the tabular statement of a system of reckoning time.

Canopus, a star otherwise called α Argūs.

Capella, a star otherwise called α Aurigæ.

Carina (keel), a portion of the constellation Argo, being the keel thereof.

Castor, a remarkable binary star, otherwise called α Geminorum.

Catoptrics (*κάτοπτρον*, a mirror); that division of the science of optics which treats of the formation of images by reflection.

Celbalrai, a star otherwise called β Ophiuchi.

Chaph, a star otherwise called β Cassiopeia.

Chronograph, an instrument intended to record by mechanical means absolute instants and intervals of time.

Circle, great; any circle on a sphere, the plane of which circle passes through the centre of the sphere, and therefore divides the sphere into two equal parts.

Circle, Mural. See vol. i. p. 149.

Circle, small; any circle on a sphere, the plane of which circle does *not* pass through the centre of the sphere, and therefore divides the sphere into two unequal parts.

Circle, Transit. See vol. i. p. 131.

Circumpolar (*circum* around, and *Polus*); the two regions of the heavens lying

- near the North and South poles respectively. The word is also used to refer to those portions of the sky which at the place of observation are always above the horizon.
- Clamp*; a contrivance for making fast for a time certain parts of an instrument which are ordinarily moveable.
- Clepsydra* (κλέπτω I carry away, and ὕδωρ water); a kind of Water-clock.
- Clock-stars*; certain stars usually employed for the regulation of clocks in an observatory, by reason of the fact that their positions have been very accurately determined.
- Co-latitude*, the complement of the latitude, or what it wants of 90° .
- Collimation, Line of* (cum with, and *lines* a limit); virtually the optical axis of a telescope.
- Colures* (κόλος clipped, and οὐρά a tail) are two great circles passing through the poles of the heavens at right angles to each other, the tail ends of which are always cut off, as it were. The equinoctial colure passes through the poles and equinox and corresponds to the hour circles of 0^h and 12^h of R.A., and the solstitial colure passes through the poles and solstices and corresponds to the hour circles of 6^h and 18^h of R.A.
- Comes* (comes a companion, plur. *comites*). The smaller of two stars forming a "Double-star" is often called the *comes* of the principal star.
- Comet* (κομήτης, hairy).
- Cometarium*, a mechanical toy invented by Desaguliers, and designed to indicate the motion of a comet or other body which follows an eccentric orbit.
- Cometography* (*comet*, and γράφω I describe); that branch of astronomy which treats specially of comets.
- Commutation, Angle of*, the distance between the Sun's true place as seen from the Earth and the place of a planet reduced to the ecliptic.
- Complement of an angle or arc*, the difference between any angle and 90° .
- Compression of the Poles of a planet* (cum together, and *premere* to squeeze); the ratio in which the Polar diameter of a planet is shorter than the Equatorial, expressed as a fraction of the equatorial diameter. Thus the Polar diameter of the Earth being $\frac{2300}{2300}$ of the Equatorial the compression is $\frac{2300}{2300}$.
- Configuration*, the relative positions of stars or other celestial bodies.
- Conjunction* (cum together, and *jungere* to join); two or more heavenly bodies are said to be in conjunction when they have the same longitude or Right Ascension.
- Constant* (cum together, and *stare* to stand); a numerical quantity always of the same value in a mathematical computation or in an astronomical reduction is called a constant. Thus the ratio of the circumference of a circle to its diameter is *constantly* about $3.1416:1$, so, knowing the diameter, we can always determine the circumference.
- Constellation* (cum together, and *stella* a star); an assemblage of stars whose outline is conceived to represent some mundane object.
- Cor Caroli*, a star otherwise called a Canum Venaticorum.
- Cor Hydra*, a star otherwise called a Hydræ.
- Cor Leonis*, a star otherwise called Regulus or a Leonis.
- Cor Serpentis*, a star otherwise called Unuk-al-hay or a Serpentis.
- Cosmical* (κόσμος, the world). A heavenly body is said to rise or set cosmically when it rises or sets at sunrise.
- Co-tidal lines*, imaginary lines running through different places on the Earth's surface where the tidal phenomena are the same at the same moment of time.
- Crepuscular* (*crepusculum*, the twilight), relating to or resembling the twilight.
- Culmination* (*culmen*, the top); the meridian passage of a heavenly body, which is then at the top of its course.
- Cursa*, a star otherwise called β Eridani.
- Curtate distance* (*curtare*, to shorten) is the distance of a planet or comet from the Sun or Earth projected upon the plane of the ecliptic.
- Cusp* (*cuspis*, a sharp point); the extremities of a crescent moon or inferior planet.
- Cycle* (κύκλος, a circle), a period within which a series of celestial phenomena recurs.
- Cynosura* (κύων, gen. κύνος a dog, and οὐρά a tail); a name occasionally given to the Pole-star, notwithstanding that that star is placed at the end of the little Bear's tail.

D.

Declination (*declinare*, to bend); the angular distance of a heavenly body from the equator—symbol, δ . According as the declination is North or South it is $+\delta$ or $-\delta$.

Degree (*degredior*, to go down; from *de* down, and *gradus* a step). The circle is conventionally divided into 360 equal parts, each of which is called a degree.

Deneb, a star otherwise called a Cygni.

Denebola, a star otherwise called β Leonis.

Density (*densus*, thick, or, close together).

Diameter (*διά* through, and *μέτρον* a measure); the breadth of anything.

Dichotomy (*δίχα* in two, and *τέμνω* I cut); a bisection. Applied to an inferior planet or the moon, it means the moment of quarter phase when the phase is a perfect semi-circle.

Differentiate, to fix the position of one celestial object by comparing it with that of another.

Digit (*digitus*, a finger); the twelfth part of the diameter of the Sun or Moon, a term formerly used to express the amount of obscuration during a solar or lunar eclipse, but now obsolete.

Dioptrics (*διά* through, *ὄπτομαι* I see); that division of the science of optics which treats of the formation of images which pass through transparent media.

Dip of the horizon, an allowance necessary to be made in reducing observations of altitude in cases where the observer's eye is elevated above the plane of the horizon. To find the Dip, multiply the square root of the height in feet by 58.795, and the product will be the dip in seconds of arc.

Disc (*discus*, a plate); the visible surface of the Sun, Moon, or planets.

Dubhe, a star otherwise called α Ursæ Majoris.

Dynamometer (*δύναμις* power, and *μέτρον* a measure); an instrument for measuring the magnifying power of lenses, &c.

E.

Eccentricity ($\epsilon\kappa$ from *κέντρον* a centre); the amount of the deviation of an elliptic orbit from a circle.

Eclipsareon, an astronomical toy invented by Ferguson to exhibit the phenomena of eclipses.

Eclipse (*ἐκλειψις*, a disappearance).

Ecliptic, the great circle of the heavens through which the Sun apparently makes a revolution in the course of a year, in consequence of the Earth's motion round that body. It derives its name from being the line on which eclipses of the Sun and Moon necessarily happen.

Ecliptic conjunction (see also *Conjunction*) is said to take place when two

bodies have the same longitude, as the Sun and Moon at New Moon.

Egress (*egredior*, I step forth) is the passing off of an inferior planet from the disc of the Sun or of a satellite from the disc of its primary at the end of the phenomenon known as a "transit."

Elements of an orbit (*elementum*, a first principle) are certain numerical quantities which define the path of a heavenly body through space.

Elevation of the Pole or of a celestial object is its angular height above the horizon, reckoned in degrees, &c. of arc.

Ellipse, one of the sections of a cone: popularly called an oval.

Ellipticity of a planet is the difference between its polar and its equatorial diameter due to the fact that it rotates on an imaginary axis passing through the poles. [See "Compression," *ante*.]

Elongation (*longè*, afar off); the angular distance Eastward or Westward of an inferior planet from the Sun, or of a satellite from its primary.

Emersion (*emergere*, to come out); the re-appearance of an object after undergoing occultation, or eclipse.

Enif, a star otherwise called ϵ Pegasi.

Epaet (*ἐπί* upon, and *ἀγω* I drive). A number used in forming the ecclesiastical calendar, and depending on the revolutions of the Earth and Moon.

Ephemeris (*ἐφημερίς*, a diary); a tabular statement of the positions of any planet or comet for any given series of days. [Prim. sig., but used generally for any table of positions.]

Epicyle (*ἐπί* on, and *κύκλος* a circle); a small circle having its centre on the circumference of a larger circle—a geometrical conception which is a leading feature of the Ptolemaic system of astronomy.

Epoch (*ἐπέχω*, I check?); the point of time to which any calculations are referred.

Equation; any number or quantity that has to be applied to the mean value of another number or quantity in order to obtain the true value.

Equation, personal; a term used in astronomy, and otherwise, to indicate some peculiarity personal to each of several observers, in virtue of which their estimates of time, for instance, differ *inter se* by some nearly constant regular amount.

Equation of equinoxes; the difference between the mean and apparent places of the equinox.

Equation of the centre; the difference be-

tween the true and mean anomalies of a planet or comet. Equal to 2ϕ . [See def. of "eccentricity."]

Equation of time; the difference between mean and apparent time.

Equator (*æquus* equal, equally dividing the sphere), *celestial*; an imaginary prolongation of the equator of the Earth, and a circle frequently referred to in astronomy.

Equatorial instrument (literally, an instrument which moves in the equator).

Equinoxes (*æquus* equal, and *nox* night); the two points where the ecliptic intersects the equator, so called because on the Sun's arrival at either of them the day is equal to the night throughout the world.

Errai, a star otherwise called γ Cephei.

Etanin, a star otherwise called γ Draconis. This star, when passing the meridian at London, is very near the zenith.

Evection (*evēhere*, to displace); a lunar inequality.

Exterior planets are those planets whose orbits lie outside that of the Earth.

F.

Falcated (*falx*, a sickle). The Moon or an inferior planet is said to be "falcated" when its illuminated portion is crescent-shaped.

Filar Micrometer (*filum*, a thread); a micrometer (q. v.) in which a thread of cobweb or fine wire is employed.

Focus (*focus*, a hearth = the central meeting place of a family); that point in which rays of light meet after having been either refracted or reflected.

Focus of an ellipse. See vol. i. p. 61.

Fomalhaut, a star other called α Piscis Australis.

G.

Galactic, having relation to the Milky Way.

Galaxy ($\gamma\acute{\alpha}\lambda\alpha$, gen. $\gamma\acute{\alpha}\lambda\alpha\kappa\tau\omicron\varsigma$ milk); a name for the Milky Way.

Geocentric ($\gamma\eta$ the Earth, and $\kappa\acute{\epsilon}\nu\tau\rho\omicron\nu$ a centre); as viewed from, or having relation to, the centre of the Earth.

Geodesy ($\gamma\eta$ the Earth, and $\delta\acute{\alpha}\iota\omega$ I divide); that branch of science which deals with the figure and dimensions of the Earth.

Gibbous (*gibbus*, hunched). When the illuminated portion of the Moon or a planet exceeds a semicircle, but is less than a circle, it is said to be gibbous.

Gnomon ($\gamma\nu\acute{\omega}\mu\omicron\nu$, an interpreter); the indicator of a sun-dial.

Gomeisa, a star otherwise called β Canis Minoris.

Gravity, terrestrial (*gravis*, heavy); the tendency inherent in all matter to fall towards the centre of the Earth.

H.

Hamal, a star otherwise called α Arietis.

Heliacal ($\eta\lambda\iota\omicron\varsigma$, the Sun). A heavenly body is said to rise or set heliacally when it first becomes visible in the morning after having been hidden by the Sun's rays, or when it first becomes lost in the Sun's rays in the evening.

Heliocentric ($\eta\lambda\iota\omicron\varsigma$ the Sun, and $\kappa\acute{\epsilon}\nu\tau\rho\omicron\nu$ the centre); as viewed from, or having relation to, the centre of the Sun.

Heliometer ($\eta\lambda\iota\omicron\varsigma$ the Sun, and $\mu\acute{\epsilon}\tau\rho\omicron\nu$ a measure); the absurd name of an instrument which is nothing more than a divided-object-glass micrometrical telescope. See vol. ii. p. 177.

Heliosat ($\eta\lambda\iota\omicron\varsigma$ the Sun, and $\zeta\tau\eta\mu\iota$ I make to stand); an instrument used in surveying which retains a reflected ray of sunlight for some time in a fixed position, notwithstanding the apparent diurnal motion of the Sun. A form of the instrument specially intended for astronomical use is called a *siderostat*.

Hemisphere ($\eta\mu\iota$ half, and $\sigma\phi\acute{\alpha}\iota\rho\alpha$ a sphere), a half-sphere; half the surface of the heavens. The celestial equator divides the celestial sphere into the Northern and Southern hemispheres, or hemispheres.

Homan, a star otherwise called ζ Pegasi.

Horary (*hora*, an hour); relating to an hour.

Horizon, artificial. See vol. ii. p. 139.

Horizon ($\omicron\rho\acute{\iota}\zeta\omega$, I bound or limit). The *sensible* horizon is that circle of the heavens which limits our view, and whose plane touches the Earth at the place of the observer, and is at right angles to the zenith. The *rational* (or *true*) horizon is parallel to the former, and passes through the centre of the Earth.

Hour angle, the distance of a heavenly body from the meridian, expressed in hours, minutes, &c.

I.

Immersion (*immergere*, to plunge into); the disappearance of an object before undergoing occultation, or eclipse.

Inclination (*inclinare*, to bend down, to slope); generally, the angle which one

plane makes with another: in particular, one of the elements of the orbit of a planet or comet—namely, the angle which the plane of the orbit makes with the plane of the ecliptic.

Inequalities (*in* not, and *æquus* equal); conventionally applied to irregularities in the motions of planets.

Inferior planet, a planet whose orbit lies within that of the earth.

Ingress (*ingredior*, to enter) is the entrance of an inferior planet on to the disc of the Sun or of a satellite on to the disc of its primary, at the commencement of the phenomenon known as a "transit."

Interior planets are those planets whose orbits lie within that of the earth.

Interstellar (*inter* in the midst, and *stella* a star). The interstellar regions of space are those parts of the universe which lie beyond the limits of the solar system.

Izar, a star otherwise called ϵ Boötis.

J.

Jovicentric (*Jupiter*, gen. *Jovis*, and *κέντρον* a centre); as viewed from, or having relation to, the centre of Jupiter.

K.

Kaus Australis, a star otherwise called ϵ Sagittarii.

Kochab, a star otherwise called β Ursæ Minoris.

Korneforos, a star otherwise called β Herculis.

L.

Latitude (*latitudo*, breadth): the angular distance of a heavenly body from the ecliptic, North or South as the case may be.

Libration (*librans*, swinging); an (apparent) oscillatory motion of the Moon.

Longitude (*longitudo*, length); the angular distance of a heavenly body from the first point of Aries measured on the ecliptic^a.

Longitude, mean; the longitude of a planet or comet, supposing it to have

moved with its mean (average) velocity.

Longitude, true; the real angular distance of a planet or comet from the first point of Aries.

Lucida (*lucidus*, bright); a word occasionally used in sidereal astronomy to indicate the brightest star of the constellation, or group, &c. mentioned.

Lumière cendrée (ash-coloured light).

Lunar (*luna*, the Moon); having reference to the Moon.

Lunation (*lunatio*, a change in the Moon); the period of the Moon's revolution round the Earth, in which it goes through all its phases, otherwise called its *synodic period*, or the lunar month.

M.

Major axis of an orbit of a planet or comet. See vol. i. p. 61.

Malus (*malus*, a mast); a portion of the constellation Argo, being the mast thereof.

Markab, a star otherwise called α Pegasi.

Mass of a planet or comet is the quantity of matter contained in it: expressed either absolutely, as the weight in so many tons; or relatively, as such and such a fraction of the mass of the Sun, or some planet.

Mean distance of a planet or comet from the Sun is the mean of the extremes of the perihelion and aphelion distances; it is equal to half the longer axis of the ellipse, whence it is frequently termed the *semi-axis major*.

Mebuta, a star otherwise called ϵ Geminorum.

Megrez, a star otherwise called δ Ursæ Majoris.

Menkab, a star otherwise called α Ceti.

Menkalinan, a star otherwise called β Aurigæ.

Meridian (*meridies*, mid-day); the great circle of the heavens passing through the zenith and the poles.

Meteor (*μετέωρος*, raised up aloft in the air), applied to bodies seen in the air, whether shooting stars, or other similar objects.

Micrometer (*μικρός* small, *μέτρον* a measure); an instrument for measuring small distances.

Minor axis of an orbit of a planet or comet. See vol. i. p. 61.

Mintaka, a star otherwise called δ Orionis.

Mira (*mirus*, wonderful), a star otherwise called \circ Ceti (= *Mira Stella*).

^a All our definitions have reference primarily to *res astronomicae*; so it may be well so to notify to the reader that some expressions (of which "longitude" is one) have a different signification in the vocabulary of geographers.

Mirach, a star otherwise called β Andromedæ.

Mirfak, a star otherwise called α Persei.

Mirzam, a star otherwise called β Canis Majoris.

Mizar, a star otherwise called ζ Ursæ Majoris.

Month, Nodal; the period in which the Moon passes from one of its nodes to the same node again.

Month, Sidereal; the period in which the Moon passes through the signs of the zodiac.

Moon-culminating Stars are certain stars which, being situated near the Moon, at any particular time are suitable points from which the angular distance of our satellite may be measured for the determination of the longitude of the place of observation.

Motion, direct. A body is said to have direct motion when it advances in the order of the signs, or when its longitude continually increases.

Motion, retrograde. A body is said to have a retrograde motion when it seems to advance contrary to the order of the signs, or when its apparent longitude continually diminishes.

N.

Nadir (*Arab. natara*, to correspond); the point immediately beneath an observer, and therefore exactly opposite the zenith.

Nath, a star otherwise called β Tauri.

Nebula (*nebula*, a fog, cognate with the Greek *νεφέλη*, a little cloud), a term applied to small cloud-like masses of stars, closely massed together.

Nekkar, a star otherwise called β Boötis.

Nocturnal arc, the arc of the heavens described by a celestial body during the night.

Node, longitude of the, is the angular distance of the place of the ascending node from the first point of Aries measured along the ecliptic.

Nodes (*nodus*, a knot) are those points in the orbit of a planet or a comet where it intersects the ecliptic. *The ascending node* (\Im) is the point where the orbit passes from the South to the North side of the ecliptic; the *descending node* ($\var�$) is the opposite point, where the orbit passes from the North to the South of the ecliptic. The imaginary line joining the nodes is called *the line of nodes*.

Nonagesimal degree of the ecliptic, otherwise called the *Medium Cæli*, is the

ninetieth degree of the ecliptic, reckoned from its intersection with the Eastern point of the horizon at any time, and is therefore that point which is at its greatest altitude above the horizon.

Nova (*nova* [*stellu*], a new star); a word introduced by Sir J. Herschel to signify a star or nebula not previously recorded.

Nucleus (*nucleus*, a kernel); the condensed portion of the head of a comet.

Nutation (*nutatio*, nodding); an oscillatory motion of the earth's axis.

O.

Oblate (*ob* against, *latus* borne). An oblate spheroid is obtained by compressing a sphere at its poles, and so causing it to bulge out at its equator; or an oblate spheroid may be defined as the solid figure generated by the revolution of an ellipse about its minor axis. If the ellipse revolves about its major axis the figure generated is a *prolate* spheroid.

Obliquity of the ecliptic (*obliquus*, slanting); the inclination of the plane of the ecliptic to the plane of the Equator.

Occlusion (*occultare*, to hide); a general word applied in particular to the eclipses of planets and stars by the Moon.

Opposition. Two celestial bodies are said to be in opposition when their longitudes differ by 180° .

Orbit (*orbis*, a circle); the path of a planet or comet round the Sun; of a satellite round a primary; or of one double star round another.

Orientation (surveying term); the general direction of a chain of triangles. [Literally, the direction with respect to the East point.]

Orrery, an astronomical toy for exhibiting the motions of the planets round the Sun; so called in honour of an Earl of Orrery in the 18th century, for whose instruction one was first made.

P.

Parabola (*Parabolic*), the figure resulting from cutting a cone in a direction parallel to one of its sides. See vol. i. p. 406.

Parallaxial Angle, see *Angle of Situation*.

Parallaxial Inequality of the Moon. See vol. i. p. 120.

Parallax (*παράλλαξις*, a change); a word variously applied in astronomy.

Parallax, Equatorial horizontal, of the Sun or Moon, is the angle subtended

- by the Earth's equatorial semi-diameter at the Sun or at the Moon.
- Parallels of Declination* are small circles parallel to the celestial equator.
- Penumbra* (*pene* almost, and *umbra* a shadow); the pale shade which encompasses the dark shadow of the Earth in an eclipse of the Moon; and which generally surrounds spots on the Sun.
- Periastræ* (*περί* near, and *ἄστρον* a star); that point in the orbit of a binary star, at which the secondary star is nearest to its primary.
- Perigee* (*περί* near, *γῆ* the Earth); the converse of *apogee* (*q. v.*).
- Perihelion* (*περί* near, and *ἥλιος* the Sun); the converse of *aphelion* (*q. v.*).
- Perihelion distance*; the least distance of a planet or comet from the Sun, usually expressed in semi-diameters of the Earth's orbit. Symbol, *q.*
- Perihelion, Longitude of*, is the angular distance of a perihelion from the first point of Aries; it is usually reckoned upon the ecliptic up to the node, and thence upon the orbit.
- Perihelion passage* is the moment of the arrival of a planet or comet at its least distance from the Sun.
- Period* (*περί* round, and *ὁδός* a path). Derivatively, period implies *space*, but it is used in reference to *time*.
- Perisaturnium*. The point in the orbit of a satellite of Saturn nearest the primary.
- Perturbation* (*perturbare*, to interfere with); the disturbance produced in the orbits of planets and comets by the effect of the attraction of other planets.
- Phact*, a star otherwise called α Columbæ.
- Phase* (*φάσις*, an appearance); applied in particular to the different appearances of the Moon during a lunation.
- Phecda*, a star otherwise called γ Ursæ Majoris.
- Photometer* (*φῶς* light, gen. *φωτός*, and *μέτρον* a measure); an instrument for determining the relative intensities of different sources of light.
- Planet* (*πλανήτης*, a wanderer); certain solid bodies which revolve round the Sun.
- Planet, secondary*. See *Satellite*.
- Planetarium*, another name for *orrery* (*q. v.*).
- Platonic year*, the period occupied by the equinoxes in performing a complete revolution: about 25,000 years.
- Polaris*, a star otherwise called α Ursæ Minoris, so named from its situation in the heavens.
- Pole* (*πολέω*, I turn); the extremities of the imaginary axis upon which the sphere and planets are regarded as rotating.
- Pollux*, a star otherwise called β Geminorum.
- Precession of the equinoxes* (*præcedere*, to go before) is a slow retrograde motion of the equinoxes, due to the attraction of the Moon, Sun, and planets on the protuberant matter of the Earth's equator.
- Prime Vertical*; the great circle passing through the zenith and the East and West points of the horizon.
- Procyon*, a star otherwise called α Canis Minoris.
- Prolate* (*pro* forwards, *latus* borne), a prolate spheroid is obtained by compressing a rotating sphere at its equator, and so causing it to bulge out at its poles.
- Puppis* (poop), a portion of the constellation Argo, being the poop thereof.

Q.

- Quadrant* (*quadrans*, a fourth part), particularly the fourth part of a circle. An instrument so called was formerly used in astronomy and navigation, but it has been superseded in the one case by the transit circle, and in the other by the sextant.
- Quadrature*. When the Moon or an inferior planet is distant one quarter of a circle, or 90° , from the Sun, it is said to be in "quadrature," E. or W. as the case may be.

R.

- Radiant Point*, a term used to designate a point of the heavens from which it is an established fact that luminous meteors are accustomed to radiate. There are a large number of such points recognised.
- Radius vector* (literally a radius carrier); an imaginary line joining the Sun and the centre of a planet or comet in any part of its orbit. It is therefore a measure of the real distance of the latter from the former.
- Ras-alhague*, a star otherwise called α Ophiuchi.
- Ras-algethi*, a star otherwise called α Herculis.
- Rate* (applied to a clock); the change

of its error from the correct time, whether sidereal or mean, during a period of 24 hours.

Reduction, the process of correcting an observation as actually made in order that it may be comparable with other observations. In reducing observations corrections may have to be applied for refraction, parallax, aberration, proper motion, epoch, clock error, and so on.

Refraction (*refrangere*, to bend); a change of direction in rays of light caused by the varying density of the medium through which the rays pass.

Regulus, a star otherwise called α or Cor Leonis.

Retrogradation, an apparent motion of the planets, in virtue of which they seem to go backwards in the ecliptic and to move contrary to the order of the signs.

Rigel, a star otherwise called β Orionis.

S.

Sad-al-melik, a star otherwise called α Aquarii.

Sad-al-sund, a star otherwise called β Aquarii.

Satellite (*satelles*, a companion); the orthodox name for what are often called moons and secondary planets; namely, the little bodies which revolve round certain of the major planets.

Saturnicentric (Saturn, and *κέντρον* a centre); as viewed from, or having relation to, the centre of Saturn.

Scheat, a star otherwise called β Pegasi. This name is also borne by δ Aquarii.

Schedar, a star otherwise called α Cassiopeiae.

Scintillation (*scintilla*, a spark); a fastidious word applied to what everybody knows as the twinkling of the stars.

Secondary planet. See *Satellite*.

Sector, *astronomical*, an instrument for finding the distance between two objects whose distance is too great to be measured by means of a micrometer in a fixed telescope.

Secular (*seculum*, an age); a term usually applied to some variation in the elements of the orbit of a planet, which is too small to be conveniently taken account of for one year and which is therefore calculated for periods of 100 years each.

Secunda Giedi, a star otherwise called α^2 Capricorni.

Selenocentric (*σελήνη* the Moon, and *κέντρον* a centre); as viewed from, or having relation to, the centre of the Moon.

Selenography (*σελήνη* the Moon, and *γράφω* I describe), the branch of descriptive astronomy which treats specially of the Moon.

Semi-diurnal arc is the half of the arc described by any heavenly body between its rising and setting.

Sexagesimal, the division of the circle by *sixties*—the circumference into 360 equal parts called "degrees;" each degree into 60 "minutes;" and each minute into 60 "seconds."

Sextant (*sextans*, a sixth part); a well-known nautical instrument, so called because its arc is the sixth part of a circle.

Sheliak, a star otherwise called β Lyræ.

Sheratan, a star otherwise called β Arietis.

Sidereal (*sidus*, a constellation); having relation to the stars.

Sign, the twelfth part of the circle of the ecliptic, or 30° thereof.

Sirius, a star otherwise called α Canis Majoris; the brightest star in the heavens. Anciently and often called the *Dog-star*.

Solar (*sol*, the Sun); having relation to the Sun.

Solstices (*sol* the Sun, and *stare* to stand still) are the two periods when the Sun reaches the northernmost and southernmost points of the ecliptic, so called because for a few days its Declination does not seem to vary. The former is called the summer and the latter the winter solstice by the inhabitants of the Northern hemisphere.

Solstitial colure; the *colure* (*q. v.*) passing through the two solstitial points whose longitudes are 90° and 270° respectively.

Sothic period; a period of 1460 years, at the completion of which, in consequence of the Egyptian year being taken at 365 days exactly, the days of the month return to the same seasons of the year.

Southing, the meridian passage of any object lying between the observer's zenith and the Southern horizon.

Speculum (*specere*, to look at); the reflector used in a reflecting telescope when such reflector is of *metal*.

Spica, a star otherwise called α Virginis.

Spring Tides, the high tides which happen about the times of New and Full Moon.

Stationary points (*stare*, to stand) of a

planet's orbit are those points at which the planet appears to us to have no motion amongst the stars.

Sub-Polo, below the pole; applied to the passage of an object across the "lower" meridian.

Sulaphat, a star otherwise called γ Lyræ.

Superior planet, a planet whose orbit lies beyond that of the Earth.

Sweep, sweeping, terms introduced by Sir W. Herschel to describe his practice of surveying the heavens by clamping his telescope in successive parallels of declination, and allowing, during a series of equal intervals of time, portions of the sky to pass under view by the diurnal motion.

Symbols ($\sigma\upsilon\mu\beta\omicron\lambda\omicron\nu$, a token) are signs constantly used by all scientific men as abbreviations in writing, to save the constant repetition of the same words and phrases. Some of the chief astronomical and mathematical ones are the following:—

SIGNS OF THE ZODIAC.

Aries	Υ
Taurus	♉
Gemini	♊
Cancer	♋
Leo	♌
Virgo	♍
Libra	♎
Scorpio	♏
Sagittarius	♐
Capricornus	♑
Aquarius	♒
Pisces	♓

The first, Υ , indicates the horns of the Ram; the second, ♉ , the head and horns of the Bull. The barb attached to a sort of letter *m* designates the Scorpion; the arrow, ♐ , sufficiently points to Sagittarius; ♑ is formed from the Greek letters $\tau\rho$, the two first letters of $\tau\rho\acute{\alpha}\gamma\omicron\varsigma$, a goat. Finally, a balance, the flowing of water, and two fishes, may be imagined in ♎ , ♒ , and ♓ , the signs of Libra, Aquarius, and Pisces^a.

THE SUN AND MAJOR PLANETS, &c.

The Sun	\odot
Mercury	♁
Venus	♀
The Earth	\oplus
The Moon	☾
Mars	♂
Jupiter	♃

^a Arago.

Saturn... ..	♄
Uranus	♅
Neptune	♆
A comet	☄
A star	★

A hammer has been suggested for the supposed Intra-Mercurial planet Vulcan.

THE MINOR PLANETS.

Ceres	♁
Pallas	♁
Juno	♁
Vesta	♁

When the number of these bodies amounted to about 20 it was found impossible to continue to give them pictorial symbols; accordingly these symbols have been dropped, except the 4 earliest ones: all planets discovered subsequently being indicated by their ordinary number surrounded by a circle. Thus—(5) ... (72)

ELEMENTS OF ORBITS OF PLANETS AND COMETS.

- M Mean anomaly.
- E Eccentric anomaly.
- v True anomaly.
- ω Distance on the orbit between the node and the perihelion in the same direction as the movement.
- λ or L Mean longitude at epoch.
- π Longitude of the perihelion, from a fixed equinox.
- \varnothing ν , Longitude of the ascending node.
- i , i , Inclination of orbit to ecliptic.
- ϕ Angle of eccentricity.
- ϵ Eccentricity (= Nat. sin. of ϕ).
- μ , n , Daily mean motion, in seconds of arc.
- a Semi-axis major, or mean distance.
- T, τ , or PP Time of perihelion passage.
- q Distance from Sun when in perihelion.
- r Length of radius vector.
- Δ Distance of the planet or comet from the Earth.

PLANETARY MOTIONS.

- ♁ Ascending node of an orbit.
- ♁ Descending node of an orbit.
- ♁ Two planets in *conjunction*: difference of longitude 0° .
- * Two planets in *sextile*: difference of longitude 60° .
- \square Two planets in *quartile* or *quadrature*: difference of longitude 90° .
- E. \square Eastern quadrature.
- W. \square Western quadrature.

- Δ Two planets in *trine*: difference of longitude 120° .
 ♀ Two planets in *opposition*: difference of longitude 180° .

URANOGRAPHICAL.

- R.A. or \mathcal{R} . or α , Right Ascension.
 Decl. or δ , Declination: +, North;
 —, South.
 N.P.D. North polar distance.
 h. Hour.
 m. Minute of *time*.
 s. Second of time.
 ° Degree.
 ' Minute of *arc*.
 " Second of *arc*.
 "' Third of *arc*. [obsolete.]
 nf. North-following.
 sf. South-following.
 sp. South-preceding.
 np. North-preceding.
 Pos. Angle of position (of double stars).
 Dist. Distance of two stars in seconds of arc.

LUNAR MOTIONS.

- Moon in conjunction, or *new*.
-) Moon at Eastern quadrature, or *first quarter*.
- Moon in opposition, or *full*.
- (Moon at Western quadrature, or *last quarter*.

MATHEMATICAL.

- + Plus; sign of addition.
- − Minus; sign of subtraction.
- × Sign of multiplication.
- ÷ Sign of division.
- + − Plus-or-minus; "somewhere about."
- = Sign of equality.
- √ Square root.
- ∛ Cube root.
- ∠ Angle.
- > Greater than.
- < Less than.
- ∞ Varies as.
- ∞∞ Infinity.

Synodical (σύν with, and ὁδός a journeying). The synodical period of two bodies revolving round the same centre is the interval elapsing between the instant of their being together and the next time they occupy the same position.

Syzygy (σύν with, and ζυγόν a yoke); the conjunction and opposition of the Moon are both termed indifferently a syzygy.

T.

Talitha, a star otherwise called ι Ursæ Majoris.

Tangent-screw. A "tangent" to a circle being a straight line which touches the circle without cutting it anywhere, a "tangent-screw" is a screw which touches the edge of a circle belonging to an astronomical instrument, which, as it is furnished with teeth to secure the screw, has a slow motion of rotation imparted to it.

Tarazad, a star otherwise called γ Aquilæ.

Telescope (τῆλε far off, and σκοπέω I view).

Telescopic. A celestial object is said to be "telescopic" when a telescope of some sort is required for viewing it.

Temporary (*tempus*, time); lasting for a short time only.

Terminator (*terminus*, a boundary); the boundary line between the illuminated and the unilluminated part of the Moon's disc.

Thuban, a star otherwise called α Draconis.

Tide (*tidan*, to happen, Sax.); the periodical rising and falling of the waters of the Ocean.

Transit (*transire*, to go across). The optical passage of an inferior planet across the Sun, or of a satellite across its primary, or of a celestial body across the meridian.

Tropics (τρέπω, I turn).

U.

Ultra-zodiacal (*ultra* beyond, and zodiac); beyond the limits of the zodiac. A term sometimes applied to the minor planets, because their orbits (or at least many of them) reach beyond the zodiac.

Umbra (*umbra*, a shadow); the shadow of the Earth, Moon, or any other planet, is in particular so called.

Unuk-al-hay, a star otherwise called α Serpentis.

Uranography (οὐρανός the heavens, and γράφω I describe); that branch of astronomy which treats specially of the sidereal heavens.

Uranometry (οὐρανός the heavens, and μέτρον a measure); the measurement of the heavens: in Latin, *Uranometria*, and in that form the title of several well-known books.

V.

- Vega*, a star otherwise called α Lyræ: sometimes spelt *Wega*.
- Velum* (a sail), gen. plural *velorum*, a portion of the constellation *Argo*, being the sails thereof.
- Vertex* (*vertex*, the top or highest point of anything); a term used to designate that point in the limb of the Sun, the Moon, or of a planet, intersected by a circle passing through the zenith and the centre of the body.
- Vertical circles*, great circles passing through the observer's zenith, and consequently through his nadir.
- Via Lactea*, the Latin word corresponding to the Greek "Galaxy" and the English "Milky Way."
- Vindemiatrix*, a star otherwise called ϵ Virginis.
- Volume* (*volumen*, bulk) of a planet or comet is its cubical contents, expressed either absolutely as so many cubic miles; or relatively as such and such a fraction of the Sun or some planet.

W.

- Wasat*, a star otherwise called δ Geminorum.

Z.

- Zaurac*, a star otherwise called γ^1 Eridani.
- Zavijava*, a star otherwise called β Virginis.
- Zenith* (Arabic), the point vertically over the head of the observer; in other words, the pole of the horizon.
- Zenith distance*, the complement of the altitude of a heavenly body; in other words, the angular distance of a heavenly body from the zenith.
- Zodiac* ($\zeta\omega\delta\iota\omicron\nu$, an animal); a belt of the heavens extending 9° on either side of the ecliptic, in which the Sun, Moon, all the major and many of the minor planets perform their annual revolutions.
- Zosma*, a star otherwise called δ Leonis.
- Zuben-el-gubi*, a star otherwise called α^2 Libræ.

INDEX.

. *This Index is designed for use in connexion with the Table of Contents.
It is not complete by itself.*

- Aberration, spherical and chromatic, of telescopes, *page* 13.
Achromatism, 14, 296.
Adjustments of Newtonian reflectors, 11; of the equatorial, 111; of the transit instrument, 129; of the sextant, 150, 161.
Age of the Moon, 448.
Airy's prismatic eye-piece, 29.
Almanac, explanation of, 444; used in observatories, 263.
Almucantar, 173.
Altazimuth, 164; mounting for reflectors, 54.
Ångström's map of the solar spectrum, 381.
Anomalistic year, 422.
Apparent noon, 419.
Artificial horizon, 155.
Ascension, Right, 447.
Astrometer, Knobel's, 191.
Astronomical instruments, 1.
Astro-photo-heliograph, 177.
Atlases, celestial, names of, 486.
Automatic spectroscope, 185.

Barlow-lens, 21.
Barlow-lens micrometer, 42.
Bedford Observatory, 196; equatorial of, 68; transit instrument of, 120, 204.
Berthon's dynamometer, 23.
Bidder's micrometer, 37.
Bissextile, 424.
Bohnenberger's collimating eye-piece, 173.
Books useful in an observatory, 263; relating to astronomy, 506.
Borda's Repeating Circle, 167.
Box-sextant, 160, 163.
Brass-work, cleaning of, 249.
Burnham's bright-wire micrometer, 40.

Cæsar, Julius, reform of the Calendar by, 424.
Calendar, Jewish, 436; Julian, 426; Gregorian, 424; Greek, 436; Roman, 427; French Revolutionary, 440.
Cassegrainian telescope, 2.
Catalogues of stars, list of, 487.
Cetus, spectrum of variable star in, 368.
Chairs and seats for observatories, 215.
Chromatic aberration, 13.
Chronograph, 135, 215.
Chronometer, 259.
Circle, Hour, 69; Mural, 165; Repeating, 167; Reflecting, 168.
Civil year, 442.
Cleaning of lenses, 248.
Clepsydra, 445.
Clock-motion for equatorials, 69, 77, 251.
Clocks for observatories, 209, 259.
Clusters and nebulæ, hints on observations of, 274.
Collimator, Kater's Floating, 170.
Colours of stars, 278.
Comet-seeker, 181.
Comets, sweeping for, 93; Hints on observations of, 274; spectra of, 342; catalogues of, 504.
Corona, spectrum of variable star in, 365.
Correction of object-glasses, 14.
Coudé equatorial at Paris, 109.
Cycle, Calippic, 436; Lunar, or Metonic, 457; Solar, 458; De Cheseaux's, 460.

- Dawes's solar eye-piece, 26, 267.
 Day, 418, 433; sidereal, 418; solar, 418.
 Declination, 447.
 Declination axis, 67.
 Dew-cap, 243.
 Diagonal eye-piece, 25.
 Dialling, 444.
 Diallyte, 17.
 Diffraction rings, 16.
 Dip of the horizon, 153.
 Dip-sector, 168.
 Distances, polar, 447.
 Dollond's telescopes, 14.
 Domes of observatories, 198.
 Dominical letter, 454.
 Double-image micrometer, 42.
 Double stars, names of catalogues of, 495;
 observations of, 276.
 Dynamometer, 23.

 Easter, 450; rules for determining it,
 450.
 Ecclesiastical calendar, 449.
 Eclipses of the Sun, 335.
 Equatorial stands, 64; English form, 67;
 German form, 71; Coudé form, 109.
 Everest's theodolite, 165.
 Eye-pieces, 13, 18, 244; Kellner's, 20;
 terrestrial, 21; pancratic, 22; dia-
 gonal, 25; powers of for different aper-
 tures, 244; Dawes's solar, 26, 267;
 Hilger's solar, 27; polarising solar, 28;
 Airy's prismatic, 29.

 "Finder" of a telescope, 50, 243.
 Focal length of eye-pieces, 19.
 Fraunhofer's investigations on the solar
 spectrum, 302.

 Galilean telescope, 18; magnifying power
 of, 20.
 Gnomons, 422, 445.
 Golden Number, 457.
 Greek year, 436.
 Greenwich Observatory, 30-ft. dome at,
 237.
 Gregorian Calendar, 424; telescope, 2.
 Grubb's terrestrial eye-piece, 23; duplex
 micrometer, 36.

 Hadley's sextant, 149.
 Hardy's noddy, 212.
 Heliometer, 177.
 Henry's photographs, 405.

 Herschelian telescope, 5.
 Hints on astronomical observations, 242.
 History of astronomy, sketch of, 468;
 of the telescope, 291.
 Hooke's joint, 52.
 Horizon, artificial, 155.
 Hour-circle, 69, 105.
 Hours, 430.
 Huggins's photographs of the solar spec-
 trum, 385.

 Illumination of wires, 37, 39, 123, 284.
 Instruments, astronomical. See the
 several instruments.

 Jewish year, 436.
 Julian Calendar, 426.
 Jupiter, hints on observations of, 272.

 Kalends, Greek, 438.
 Kater's mercurial clepsydra, 445; Float-
 ing Collimators, 170.
 Kellner's eye-piece, 20.
 Kirchhoff's spectroscopic researches, 303;
 his map of the spectrum, 379.
 Konkoly's treatise on astronomical photo-
 graphy mentioned, 416.

 La Place on the week, 433.
 Latitude, to find, 140, 156.
 Level, Striding, 119.
 Levels, tests for, 130.
 Lick Observatory, 238, 247.
 Lockyer's division of the stars into
 groups, 360.
 Logarithm books, 265.

 Magnitudes of stars, 282.
 Mahometan year, 438.
 Maps, astronomical, 264, 502; of the
 spectrum, 379.
 Mean noon, 419.
 Melbourne Observatory, 106.
 Meridian circle, 147.
 Meridian mark, 206.
 Meteorological instruments for observa-
 tories, 220.
 Meteors, spectra of, 350.
 Metonic Cycle, 457.
 Micrometer, reticulated, 30; parallel-
 wire, 32; position, 35; Grubb's duplex,
 36; Bidder's, 37; Burnham's, 38;
 double-image, 42; Ring, 43.
 Mira Ceti, 368.

- Mirrors of telescopes, Browning's method of mounting, 10.
 Months, 435; derivations of the names of, 437.
 Moon, transit observations of, 136; general observations of, 269; spectrum of, 339.
 Motion of the Sun in the ecliptic, 419; of the stars through space, 372.
 Mural circle, 165.

 Nasmyth's Newtonian telescope, 9.
 Nebulæ, spectra of, 369; catalogues of, 499.
 Negative eye-piece, 19.
 Newton's experiment on light, 299.
 Newtonian telescope, 2.
 Noddy, 212.
 Noon, mean, 419.

 Object-glass, 13, 243; list of large ones, 296.
 Observatory, 193, 251; choice of site for, 195; foundations of, 196; Admiral Smyth's at Bedford, 196; at Queen's College, Cork, 203; meridian mark for, 206; clock for, 209; observing chairs and seat for, 215; meteorological instruments for, 220; plans and specifications for, 221; at East-Bourne, 226; at Austwick, 229; lamp for use in, 283; clothing for use in, 284.
 Observing chairs, 215.
 Opera-glass, 18.
 Orbit-sweeper, 177.

 Parallax ladder, 252.
 Paris Observatory, 109, 177.
 Period, Dionysian, 459; Julian, 459.
 Periodical Publications relating to Astronomy, 263.
 Personal equation, 129; instrument, 187.
 Photography, solar, 395; general account of astronomical, 390.
 Photometer, 188.
 Photometry of the stars, 188, 280.
 Pillar-and-claw stand, 49; conversion of, into equatorial, 65.
 Planets, Transit Observations of, 136; general observations of, 270; spectra of, 339.
 Pole-star, 140.
 Position, angles of, 35.

 Positive eye-piece, 18.
 Prismatic eye-piece (Airy's), 29.
 Prismatic sextant, 163.
 Pritchard's wedge photometer, 188.

 Quadrature, 448.
 Quarter days, 443.

 Rainband, 315.
 Ramsden's dynamometer, 23.
 Rating instrument, 144.
 Reckonings, astronomical and chronological, the difference between, 460.
 Reflecting circle, 167.
 Reflecting telescope, 2, 9, 103, 242, 249.
 Reflex zenith-tube, 170.
 Reformation of Calendar, by Julius Cæsar, 424; by Pope Gregory XIII., 425.
 Refracting telescopes compared with reflecting telescopes, 13.
 Refractions, Table of, 530.
 Repeating circle, 168.
 Right Ascension, 447.
 Ring micrometer, 43.
 Roman year, 437.
 Rosse, Earl of, telescope of, 6.

 Saturn, hints on observations of, 271.
 Secchi's types of stars, 354.
 Sector, Dip-, 168; Zenith-, 168.
 Semi-diameter, correction for, 153.
 Setting circle, 206.
 Sextant, 149; box-, 160, 163; prismatic, 163.
 Sidereal day, 418; year, 422.
 Sidereal time indicator, 260.
 Siderostat, 181.
 Sisson's equatorial, 67.
 Slipping-piece, 45.
 Solar cycle, 458.
 Spectroscope, 182.
 Spectroscopic astronomy, 298.
 Spherical aberration, 13.
 Smeaton's block, 63.
 Smyth, Admiral W. H., his observatory, 196; Hints by, to observers, 286.
 Stands for telescopes, 48, 250.
 Star-finder, 95.
 Stars, hints on observations of, 275; spectra of, 352.
 Stars, Catalogues of, 265, 487.
 Steinheil's transit prism, 259.

- Striding level, 130.
 Styles, Old and New, 428.
 Suggestions for carrying on astronomical observations, 242.
 Sun, hints on observing the, 266; spectroscopic observations of, 308.
 Sunday, 434.
 Sunday letter, 454.
 Sun-dial, 444.
 Sweeping for comets, &c., 93.

 Tables of Equation of Time, 421; for the Conversion of Time, 518; for ascertaining Dates of Events, 528; of Refraction, 530; of Precession, 537.
 Tail-piece, 50.
 Telescopes, 1, 291; Reflecting, 2, 54, 103; Refracting, 9, 242, 291; history of, 291.
 Telluric lines, 311.
 Tests for telescopes, 15, 17; for levels, 130.
 Time, determination of, by transit instrument, 134; by the sextant, 160.
 Transit circle, 147.
 Transit instrument, 118; illumination of, 121; wires of, 119; form for recording observations, 287.
 Transit prism, Steinheil's, 259.
 Transit theodolite, 165.
 Triangular star discs, 276.
 Tubes for telescopes, 46.
 "Twin" equatorial, 103.

 Variable stars, spectra of, 365.
 Varley's stand, 53.
 Venus, hints on observations of, 270.
 Vocabulary of Definitions, 541.
 Vogel's types of stars, 359.

 Washburn Observatory, 237.
 Week, Days of the, 433.
 Window equatorial, 78.
 Window transit instrument, 143, 144.

 Year, 442; mean sidereal, 422; anomalous, 422; mean solar, 423; of different nations, 436.
 Zenith sector, 168; -tube, reflex, 170.
 Zodiacal Light, spectrum of, 338.

In Demy 8vo., pp. 696, with 52 Illustrations, price 12s.

"The work is one of sterling merit, which not improbably will exercise a considerable and beneficial influence on its department of science."—Sir G. B. AIRY, K.C.B., F.R.S., late Astronomer Royal.

A CYCLE
OF
CELESTIAL OBJECTS

OBSERVED, REDUCED, AND DISCUSSED

BY

ADMIRAL WILLIAM HENRY SMYTH, R.N., K.S.F., D.C.L.

REVISED, CONDENSED, AND GREATLY ENLARGED

BY

GEORGE F. CHAMBERS, F.R.A.S.

OF THE INNER TEMPLE, BARRISTER-AT-LAW,

Author of "A Handbook of Descriptive Astronomy;"

"A Digest of the Law Relating to Public Health;"

"A Digest of the Law Relating to Public Libraries and Museums;"

"A Handbook for Public Meetings;"

and other Works.

SECOND EDITION.

Oxford:

AT THE CLARENDON PRESS.

LONDON: HENRY FROWDE,

OXFORD UNIVERSITY PRESS WAREHOUSE, AMEN CORNER, E.C.

Lately published, pp. xxxii, 676, cloth, price Twenty-one Shillings.

A HANDBOOK
OF
DESCRIPTIVE AND PRACTICAL
ASTRONOMY.

BY

GEORGE F. CHAMBERS, F.R.A.S.,

OF THE INNER TEMPLE, BARRISTER-AT-LAW ;

*Author of "A Practical and Conversational English, French, and German Dictionary;"
"The Tourist's Pocket-Book;" "A Digest of the Law relating to Public
Health;" "A Digest of the Law relating to Public Libraries
and Museums;" "A Handbook for Public Meetings;"
and other Works.*

The heavens declare the glory of God ; and the firmament sheweth his handywork."
Psalm xix. 1.

I.

THE SUN, PLANETS, AND COMETS.

FOURTH EDITION.

FIG. 2.



August 26.

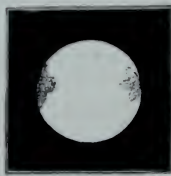

September 9.

THE IIIrd SATELLITE OF JUPITER IN 1855. (*Secchi.*)

Oxford:

AT THE CLARENDON PRESS.

LONDON: HENRY FROWDE,

OXFORD UNIVERSITY PRESS WAREHOUSE, AMEN CORNER, E.C.

Clarendon Press, Oxford.

SELECT LIST OF STANDARD WORKS.

DICTIONARIES	Page 1.
LAW	„ 2.
HISTORY, BIOGRAPHY, ETC.	„ 3.
PHILOSOPHY, LOGIC, ETC.	„ 6.
PHYSICAL SCIENCE	„ 7.

1. DICTIONARIES.

A New English Dictionary on Historical Principles, founded mainly on the materials collected by the Philological Society. Edited by James A. H. Murray, LL.D. Imperial 4to. In Parts, price 12s. 6d. each.

Vol. I (A and B), half-morocco, 2l. 12s. 6d.

Part IV, Section 2, C—CASS, beginning Vol. II, price 5s.

Part V, CAST—CLIVY, price 12s. 6d.

Part VI, CLO—CONSIGNER, price 12s. 6d.

Vol. III, Part I, E—EVERY, edited by Henry Bradley, M.A., with the co-operation of Dr. Murray, price 12s. 6d.

An Etymological Dictionary of the English Language, arranged on an Historical Basis. By W. W. Skeat, Litt.D. *Second Edition.* 4to. 2l. 4s.

A Middle-English Dictionary, containing Words used by English Writers from the Twelfth to the Fifteenth Century. By Francis Henry Stratmann. A new edition, re-arranged, revised, and enlarged by Henry Bradley. 4to, half-bound, 1l. 11s. 6d.

An Anglo-Saxon Dictionary, based on the MS. collections of the late Joseph Bosworth, D.D. Edited and enlarged by Prof. T. N. Toller, M.A., Owens College, Manchester. Parts I-III. A—SAR. 4to, stiff covers. 15s. each. Part IV, § 1, stiff covers, 8s. 6d. *Just Published.*

An Icelandic-English Dictionary, based on the MS. collections of the late Richard Cleasby. Enlarged and completed by G. Vigfússon, M.A. With an Introduction, and Life of Richard Cleasby, by G. Webbe Dasent, D.C.L. 4to. 3l. 7s.

A Greek-English Lexicon, by H. G. Liddell, D.D., and Robert Scott, D.D. *Seventh Edition, Revised and Augmented throughout.* 4to. 1l. 16s.

- An Intermediate Greek-English Lexicon**, founded upon the Seventh Edition of Liddell and Scott's Greek Lexicon. Small 4to. 12s. 6d.
- A Latin Dictionary**, founded on Andrews' edition of Freund's Latin Dictionary, revised, enlarged, and in great part rewritten by Charlton T. Lewis, Ph.D., and Charles Short, LL.D. 4to. 1l. 8s.
- A School Latin Dictionary**. By Charlton T. Lewis, Ph.D. Small 4to. 18s.
- A Sanskrit-English Dictionary**. Etymologically and Philologically arranged, with special reference to Greek, Latin, German, Anglo-Saxon, English, and other cognate Indo-European Languages. By Sir M. Monier-Williams, D.C.L. 4to. 4l. 14s. 6d.
- Thesaurus Syriacus**: collegerunt Quatremère, Bernstein, Lorsbach, Arnoldi, Agrell, Field, Roediger; edidit R. Payne Smith, S.T.P. Vol. I, containing Fasc. I-V, sm. fol. 5l. 5s.
Fasc. VI. 1l. 1s. Fasc. VII. 1l. 11s. 6d. Fasc. VIII. 1l. 16s.

2. LAW.

- Anson**. *Principles of the English Law of Contract, and of Agency in its Relation to Contract*. By Sir W. R. Anson, D.C.L. Sixth Edition. 8vo. 10s. 6d.
- *Law and Custom of the Constitution*. Part I. Parliament. 8vo. 10s. 6d.
- Bentham**. *An Introduction to the Principles of Morals and Legislation*. By Jeremy Bentham. Crown 8vo. 6s. 6d.
- Digby**. *An Introduction to the History of the Law of Real Property*. By Kenelm E. Digby, M.A. Third Edition. 8vo. 10s. 6d.
- Grueber**. *Lex Aquilia*. The Roman Law of Damage to Property: being a Commentary on the Title of the Digest 'Ad Legem Aquilianam' (ix. 2). With an Introduction to the Study of the Corpus Iuris Civilis. By Erwin Grueber, Dr. Jur., M.A. 8vo. 10s. 6d.
- Hall**. *International Law*. By W. E. Hall, M.A. Third Edition. 8vo. 22s. 6d.
- Holland**. *Elements of Jurisprudence*. By T. E. Holland, D.C.L. Fifth Edition. 8vo. 10s. 6d.
- *The European Concert in the Eastern Question*; a Collection of Treaties and other Public Acts. Edited, with Introductions and Notes, by T. E. Holland, D.C.L. 8vo. 12s. 6d.
- Holland**. *Gentilis, Alberici, De Iure Belli Libri Tres*. Edidit T. E. Holland, I.C.D. Small 4to. half-morocco, 21s.
- Holland**. *The Institutes of Justinian*, edited as a recension of the Institutes of Gaius, by T. E. Holland, D.C.L. Second Edition. Extra fcap. 8vo. 5s.

Holland and Shadwell. *Select Titles from the Digest of Justinian.* By T. E. Holland, D.C.L., and C. L. Shadwell, B.C.L. 8vo. 14s.

Also sold in Parts, in paper covers, as follows:—

Part I. Introductory Titles. 2s. 6d.

Part II. Family Law. 1s.

Part III. Property Law. 2s. 6d.

Part IV. Law of Obligations (No. 1). 3s. 6d.

Part IV. Law of Obligations (No. 2). 4s. 6d.

Markby. *Elements of Law considered with reference to Principles of General Jurisprudence.* By Sir William Markby, D.C.L. Fourth Edition. 8vo. 12s. 6d.

Moyle. *Imperatoris Iustiniani Institutionum Libri Quattuor;* with Introductions, Commentary, Excursus and Translation. By J. B. Moyle, D.C.L. Second Edition. 2 vols. 8vo. Vol. I. 16s. Vol. II. 6s.

Pollock and Wright. *An Essay on Possession in the Common Law.* By Sir F. Pollock, M.A., and R. S.

Wright, B.C.L. (Now the Hon. Mr. JUSTICE WRIGHT). 8vo. 8s. 6d.

Poste. *Gaii Institutionum Juris Civilis Commentarii Quattuor;* or, Elements of Roman Law by Gaius. With a Translation and Commentary by Edward Poste, M.A. 8vo. 18s.

Raleigh. *An Outline of the Law of Property.* By Thos. Raleigh, M.A. 8vo. 7s. 6d.

Stokes. *The Anglo-Indian Codes.* By Whitley Stokes, LL.D.

Vol. I. Substantive Law. 8vo. 30s.

Vol. II. Adjective Law. 8vo. 35s.

First and Second Supplements to the above, incorporating Indian Legislation and Judicial Decisions to May 31, 1891. 8vo, 6s. 6d. Separately, No. 1, 2s. 6d.; No. 2, 4s. 6d.

Twiss. *The Law of Nations considered as Independent Political Communities.* By Sir Travers Twiss, D.C.L.

Part I. On the Rights and Duties of Nations in time of Peace. New Edition. 8vo. 15s.

Part II. On the Rights and Duties of Nations in time of War. 21s.

3. HISTORY, BIOGRAPHY, ETC.

Baker's Chronicle. *Chronicon Galfridi le Baker de Swynebroke.* Edited with Notes by Edward Maunde Thompson, Hon. LL.D. St. Andrews; Hon. D.C.L. Durham; F.S.A.; Principal Librarian of the British Museum. Small 4to, stiff covers, 18s.; cloth, gilt top, 21s.

Bentham. *A Fragment on Government.* By Jeremy Bentham.

Edited with an Introduction by F. C. Montague, M.A. 8vo. 7s. 6d.

Bentham. *An Introduction to the Principles of Morals and Legislation.* By Jeremy Bentham. Crown 8vo. 6s. 6d.

Boswell's Life of Samuel Johnson, LL.D. Edited by G. Birkbeck Hill, D.C.L. In six volumes, medium 8vo. With Portraits and Facsimiles. Half-bound, 3l. 3s.

Calendar of the Clarendon State Papers, preserved in the Bodleian Library. In three volumes. 1869-76.

Vol. I. From 1523 to January 1649. 8vo. 18s.

Vol. II. From 1649 to 1654. 16s.

Vol. III. From 1655 to 1657. 14s.

Calendar of Charters and Rolls preserved in the Bodleian Library. 8vo. 1l. 11s. 6d.

Carte's Life of James Duke of Ormond. 6 vols. 8vo. 1l. 5s.

Clarendon's History of the Rebellion and Civil Wars in England. Re-edited from a fresh collation of the original MS. in the Bodleian Library, with marginal dates and occasional notes, by W. Dunn Macray, M.A., F.S.A. 6 vols. Crown 8vo. 2l. 5s.

— *History of the Rebellion and Civil Wars in England.* To which are subjoined the Notes of Bishop Warburton. 7 vols. medium 8vo. 2l. 10s.

— *History of the Rebellion and Civil Wars in England.* Also his Life, written by himself, in which is included a Continuation of his History of the Grand Rebellion. Royal 8vo. 1l. 2s.

— *Life, including a Continuation of his History.* 2 vols. medium 8vo. 1l. 2s.

Earle. Handbook to the Land-Charters, and other Saxon Documents. By John Earle, M.A., Professor of Anglo-Saxon in the University of Oxford. Crown 8vo. 16s.

Finlay. A History of Greece from its Conquest by the Romans to the present time, B. C. 146 to A. D. 1864. By George Finlay, LL.D. A new Edition, revised throughout, and in part re-written, with considerable additions, by the Author, and edited by H. F. Tozer, M.A. 7 vols. 8vo. 3l. 10s.

Fortescue. The Governance of England: otherwise called *The Difference between an Absolute and a Limited Monarchy.* By Sir John Fortescue, Kt. A Revised Text. Edited, with Introduction, Notes, &c., by Charles Plummer, M.A. 8vo, half-bound, 12s. 6d.

Freeman. The History of Sicily from the Earliest Times. Vols. I. and II. 8vo. Cloth, 2l. 2s. *Just Published.*

— *History of the Norman Conquest of England; its Causes and Results.* By E. A. Freeman, D.C.L. In Six Volumes. 8vo. 5l. 9s. 6d.

— *The Reign of William Rufus and the Accession of Henry the First.* 2 vols. 8vo. 1l. 16s.

— *A Short History of the Norman Conquest of England. Second Edition.* Extra fcap. 8vo. 2s. 6d.

Gardiner. The Constitutional Documents of the Puritan Revolution, 1628-1660. Selected and Edited by Samuel Rawson Gardiner, M.A. Crown 8vo. 9s.

Gascoigne's Theological Dictionary ('*Liber Veritatum*'): Selected Passages, illustrating the Condition of Church and State, 1403-1458. With an Introduction by James E. Thorold Rogers, M.A. 4to. 10s. 6d.

- Greswell.** *History of the Dominion of Canada.* By W. PARR GRESWELL, M.A. Under the auspices of the Royal Colonial Institute. Crown 8vo. With Eleven Maps. 7s. 6d.
- *Geography of the Dominion of Canada and Newfoundland.* By the same Author. Crown 8vo. With Ten Maps. 6s.
- Gross.** *The Guild Merchant; a Contribution to British Municipal History.* By Charles Gross, PH.D. Instructor in History, Harvard University. 2 vols. 8vo. Half-bound, 24s.
- Hodgkin.** *Italy and her Invaders.* With Plates and Maps. By T. Hodgkin, D.C.L. Vols. I-IV, A.D. 376-553. 8vo. 3l. 8s.
- *The Dynasty of Theodosius; or, Seventy Years' Struggle with the Barbarians.* By the same Author. Crown 8vo. 6s.
- Hume.** *Letters of David Hume to William Strahan.* Edited with Notes, Index, &c., by G. Birkbeck Hill, D.C.L. 8vo. 12s. 6d.
- Kitchin.** *A History of France.* With Numerous Maps, Plans, and Tables. By G. W. Kitchin, D.D. In three Volumes. *Second Edition.* Crown 8vo, each 10s. 6d.
Vol. I. to 1453. Vol. II. 1453-1624. Vol. III. 1624-1793.
- Luttrell's (Narcissus) Diary.** A Brief Historical Relation of State Affairs, 1678-1714. 6 vols. 8vo. 1l. 4s.
- Lucas.** *Introduction to a Historical Geography of the British Colonies.* By C. P. Lucas, B.A. With Eight Maps. Crown 8vo. 4s. 6d.
- Lucas.** *Historical Geography of the British Colonies:*
Vol. I. The Mediterranean and Eastern Colonies (exclusive of India). With Eleven Maps. Crown 8vo. 5s.
Vol. II. The West Indian Colonies. With Twelve Maps. Crown 8vo. 7s. 6d.
- Machiavelli.** *Il Principe.* Edited by L. Arthur Burd, M.A. With an Introduction by Lord Acton. 8vo. Cloth, 14s.
- Ranke.** *A History of England, principally in the Seventeenth Century.* By L. von Ranke. Translated under the superintendence of G. W. Kitchin, D.D., and C. W. Boase, M.A. 6 vols. 8vo. 3l. 3s.
- Rawlinson.** *A Manual of Ancient History.* By George Rawlinson, M.A. *Second Edition.* 8vo. 14s.
- Rhÿs.** *Studies in the Arthurian Legend.* By John Rhÿs, M.A. 8vo. 12s. 6d.
- Ricardo.** *Letters of David Ricardo to T. R. Malthus (1810-1823).* Edited by James Bonar, M.A. 8vo. 10s. 6d.
- Rogers.** *History of Agriculture and Prices in England, A.D. 1259-1702.* By James E. Thorold Rogers, M.A. 6 vols., 8vo. 7l. 2s.
- *First Nine Years of the Bank of England.* 8vo. 8s. 6d.
- *Protests of the Lords, including those which have been expunged, from 1624 to 1874; with Historical Introductions.* In three volumes. 8vo. 2l. 2s.
- Smith's Wealth of Nations.** With Notes, by J. E. Thorold Rogers, M.A. 2 vols. 8vo. 21s.

- Sprigg's** *England's Recovery*; being the History of the Army under Sir Thomas Fairfax. 8vo. 6s.
- Stubbs.** *Select Charters and other Illustrations of English Constitutional History, from the Earliest Times to the Reign of Edward I.* Arranged and edited by W. Stubbs, D.D., Lord Bishop of Oxford. *Seventh Edition.* Crown 8vo. 8s. 6d.
- *The Constitutional History of England, in its Origin and Development. Library Edition.* 3 vols. Demy 8vo. 2l. 8s.
Also in 3 vols. crown 8vo. price 12s. each.
- *Seventeen Lectures on the Study of Medieval and Modern History, delivered at Oxford 1867-1884.* Crown 8vo. 8s. 6d.
- Stubbs.** *Registrum Sacrum Anglicanum.* An attempt to exhibit the course of Episcopal Succession in England. By W. Stubbs, D.D. Small 4to. 8s. 6d.
- Wellesley.** *A Selection from the Despatches, Treaties, and other Papers of the Marquess Wellesley, K.G., during his Government of India.* Edited by S. J. Owen, M.A. 8vo. 1l. 4s.
- Wellington.** *A Selection from the Despatches, Treaties, and other Papers relating to India of Field-Marshal the Duke of Wellington, K.G.* Edited by S. J. Owen, M.A. 8vo. 1l. 4s.
- Whitelock's** *Memorials of English Affairs from 1625 to 1660.* 4 vols. 8vo. 1l. 10s.

4. PHILOSOPHY, LOGIC, ETC.

- Bacon.** *The Essays.* With Introduction and Illustrative Notes. By S. H. REYNOLDS, M.A. 8vo, half-bound. 12s. 6d.
- *Novum Organum.* Edited, with Introduction, Notes, &c., by T. Fowler, D.D. *Second Edition.* 8vo. 15s.
- *Novum Organum.* Edited, with English Notes, by G. W. Kitchin, D.D. 8vo. 9s. 6d.
- *Novum Organum.* Translated by G. W. Kitchin, D.D. 8vo. 9s. 6d.
- Berkeley.** *The Works of George Berkeley, D.D., formerly Bishop of Cloyne; including many of his writings hitherto unpublished.* With Prefaces, Annotations, and an Account of his Life and Philosophy, by Alexander Campbell Fraser, LL.D. 4 vols. 8vo. 2l. 18s.
The Life, Letters, &c., separately, 16s.
- Bosanquet.** *Logic; or, the Morphology of Knowledge.* By B. Bosanquet, M.A. 8vo. 21s.
- Butler's Works, with Index to the Analogy.** 2 vols. 8vo. 11s.
- Fowler.** *The Elements of Deductive Logic, designed mainly for the use of Junior Students in the Universities.* By T. Fowler, D.D. *Ninth Edition,* with a Collection of Examples. Extra fcap. 8vo. 3s. 6d.
- *The Elements of Inductive Logic, designed mainly for the use of Students in the Universities.* By the same Author. *Fifth Edition.* Extra fcap. 8vo. 6s.

- Fowler.** *The Principles of Morals.* (Introductory Chapters.) By T. Fowler, D.D., and J. M. Wilson, B.D. 8vo, boards, 3s. 6d.
- *The Principles of Morals.* Part II. By T. Fowler, D.D. 8vo. 10s. 6d.
- Green.** *Prolegomena to Ethics.* By T. H. Green, M.A. Edited by A. C. Bradley, M.A. 8vo. 12s. 6d.
- Hegel.** *The Logic of Hegel*; translated from the Encyclopaedia of the Philosophical Sciences. With Prolegomena by William Wallace, M.A. 8vo. 14s.
- Hume's Treatise of Human Nature.** Edited, with Analytical Index, by L. A. Selby-Bigge, M.A. Crown 8vo. 9s.
- Locke's Conduct of the Understanding.** Edited by T. Fowler, D.D. *Third Edition.* Extra fcap. 8vo. 2s. 6d.
- Lotze's Logic, in Three Books**; of Thought, of Investigation, and of Knowledge. English Translation; Edited by B. Bosanquet, M.A. *Second Edition.* 2 vols. Cr. 8vo. 12s.
- *Metaphysic, in Three Books*; Ontology, Cosmology, and Psychology. English Translation; Edited by B. Bosanquet, M.A. *Second Edition.* 2 vols. Cr. 8vo. 12s.
- Martineau.** *Types of Ethical Theory.* By James Martineau, D.D. *Third Edition.* 2 vols. Cr. 8vo. 15s.
- *A Study of Religion: its Sources and Contents.* *Second Edition.* 2 vols. Cr. 8vo. 15s.

5. PHYSICAL SCIENCE.

- Aplin.** *The Birds of Oxfordshire.* By O. V. Aplin. 8vo. 10s. 6d.
- Chambers.** *A Handbook of Descriptive and Practical Astronomy.* By G. F. Chambers, F.R.A.S. *Fourth Edition,* in 3 vols. Demy 8vo.
Vol. I. The Sun, Planets, and Comets. 21s.
Vol. II. Instruments and Practical Astronomy. 21s.
Vol. III. The Starry Heavens. 14s.
- De Bary.** *Comparative Anatomy of the Vegetative Organs of the Phanerogams and Ferns.* By Dr. A. de Bary. Translated and Annotated by F. O. Bower, M.A., F.L.S., and D. H. Scott, M.A., Ph.D., F.L.S. Royal 8vo, half-morocco, 1l. 2s. 6d.
- *Comparative Morphology and Biology of Fungi, Mycetozoa and Bacteria.* By Dr. A. de Bary. Translated by H. E. F. Garnsey, M.A. Revised by Isaac Bayley
- Balfour, M.A., M.D., F.R.S. Royal 8vo, half-morocco, 1l. 2s. 6d.
- De Bary.** *Lectures on Bacteria.* By Dr. A. de Bary. *Second Improved Edition.* Translated by H. E. F. Garnsey, M.A. Revised by Isaac Bayley Balfour, M.A., M.D., F.R.S. Crown 8vo. 6s.
- Fisher.** *A Class Book of Elementary Chemistry.* By W. W. Fisher, M.A., F.C.S. Crown 8vo. 4s. 6d.
- Chemistry in Space.** By Van't Hoff. Translated and edited by J. E. Marsh, B.A. Crown 8vo. 4s. 6d.
- Goebel.** *Outlines of Classification and Special Morphology of Plants.* A new Edition of Sachs' Text-Book of Botany, Book II. By Dr. K. Goebel. Translated by H. E. F. Garnsey, M.A. Revised by Isaac Bayley Balfour, M.A., M.D., F.R.S. Royal 8vo, half-morocco, 1l. 1s.

Sachs. *Lectures on the Physiology of Plants.* By Julius von Sachs. Translated by H. Marshall Ward, M.A., F.L.S. Royal 8vo, half-morocco, 1l. 11s. 6d.

— *A History of Botany.* Translated by H. E. F. Garnsey, M.A. Edited by I. Bayley Balfour, M.A., M.D., F.R.S. Crown 8vo. 10s.

Fossil Botany. *Being an Introduction to Palaeophytology from the Standpoint of the Botanist.* By H. Graf zu Solms-Laubach. Translated by H. E. F. Garnsey, M.A. Edited by I. Bayley Balfour, M.A., M.D., F.R.S. Royal 8vo, half-morocco, 18s.

Annals of Botany. Edited by Isaac Bayley Balfour, M.A., M.D., F.R.S., Sydney H. Vines, D.Sc., F.R.S., and W. G. Farlow, M.D.

Vol. I. Parts I-IV. Royal 8vo, half-morocco, gilt top, 1l. 16s.

Vol. II. Parts V-VIII. 2l. 2s.

Vol. III. Part IX. 11s. 6d.; X. 13s. 6d.; XI. 18s.;

XII. *In the Press.*

Vol. IV. Part XIII. 12s. 6d.;

XIV. 13s. 6d.; XV. 10s. 6d.;

XVI. *In the Press.*

Vol. V. Part XVII. 10s. 6d.

Biological Series. (*Translations of Foreign Biological Memoirs.*)

I. *The Physiology of Nerve, of Muscle, and of the Electrical Organ.* Edited by J. Burdon-Sanderson, M.D., F.R.S.S. L. & E. Medium 8vo. 1l. 1s.

II. *The Anatomy of the Frog.* By Dr. Alexander Ecker, Professor in the University of Freiburg. Translated, with numerous Annotations and Additions, by G. Haslam, M.D. Med. 8vo. 21s.

III. *Contributions to the History of the Physiology of the Nervous System.* By Professor Conrad Eckhard. Translated by Miss Edith Prance. *In Preparation.*

IV. *Essays upon Heredity and Kindred Biological Problems.* By Dr. A. Weismann. Translated and Edited by E. B. Poulton, M.A., S. Schönland, Ph.D., and A. E. Shipley, M.A. *Second Edition.* Crown 8vo. 7s. 6d.

Prestwich. *Geology, Chemical, Physical, and Stratigraphical.* By Joseph Prestwich, M.A., F.R.S. In two Volumes.

Vol. I. Chemical and Physical. Royal 8vo. 1l. 5s.

Vol. II. Stratigraphical and Physical. With a new Geological Map of Europe. Royal 8vo. 1l. 16s.

New Geological Map of Europe. In case or on roller. 5s.

Rolleston and Jackson. *Forms of Animal Life.* A Manual of Comparative Anatomy, with descriptions of selected types. By George Rolleston, M.D., F.R.S. *Second Edition.* Revised and Enlarged by W. Hatchett Jackson, M.A. Medium 8vo. 1l. 16s.

Oxford

AT THE CLARENDON PRESS

LONDON: HENRY FROWDE

OXFORD UNIVERSITY PRESS WAREHOUSE, AMEN CORNER, E.C.

1000
1000

DESIGN FOR AN OBSERVATORY FOR A 7 FT TELESCOPE AND A TRANSIT INSTRUMENT.

A.

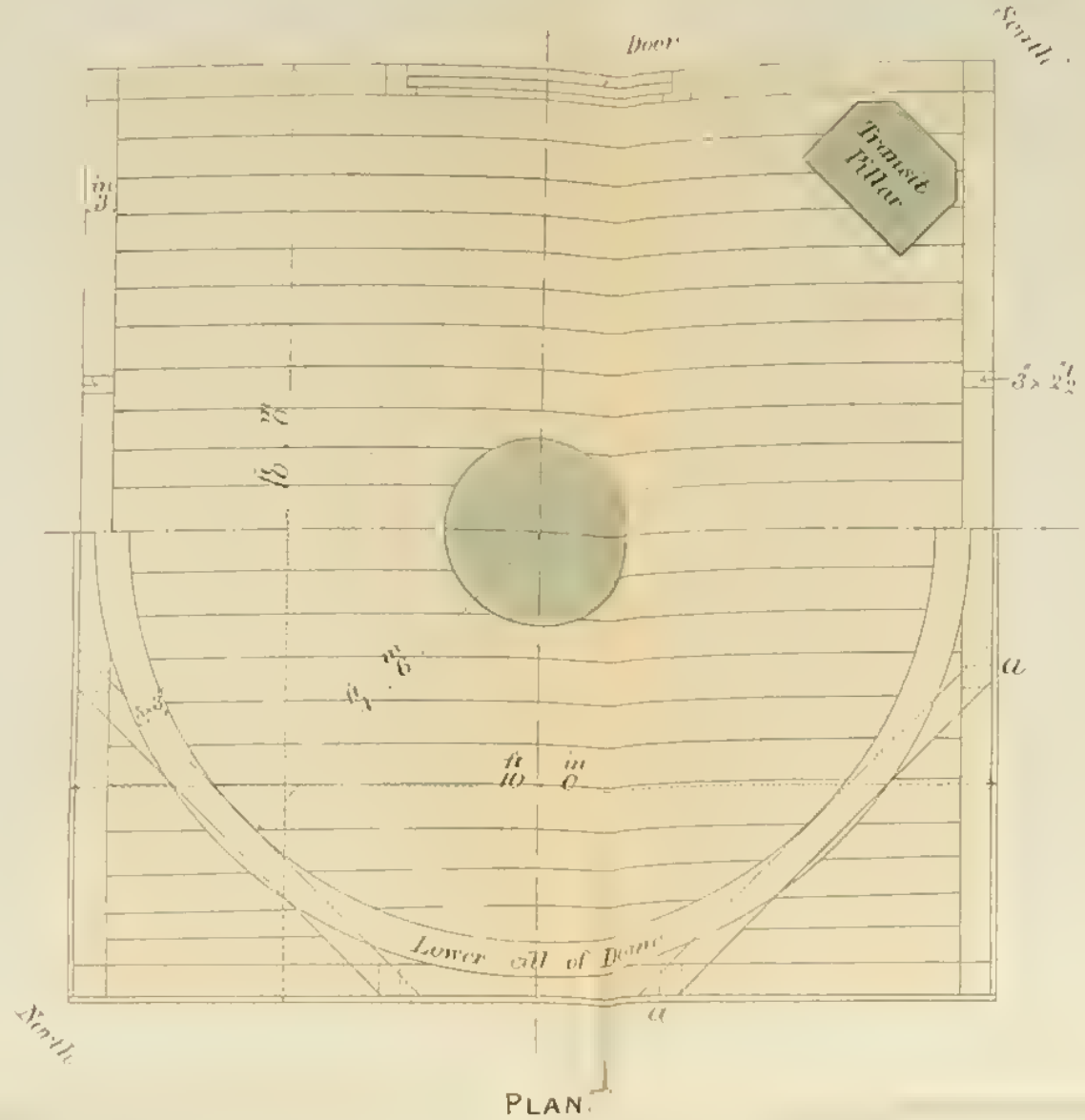

PLAN.

B.

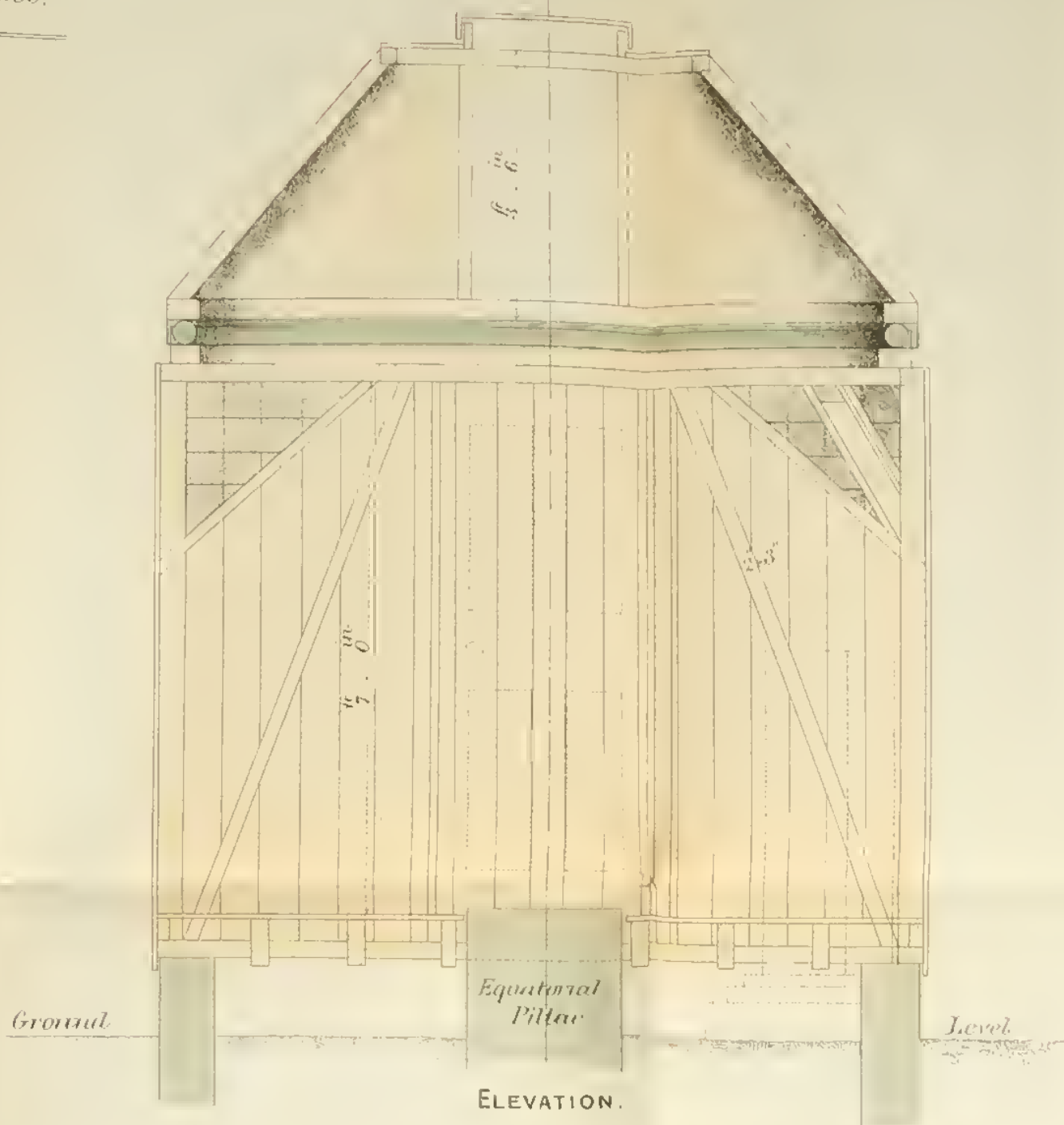

ELEVATION.

C.

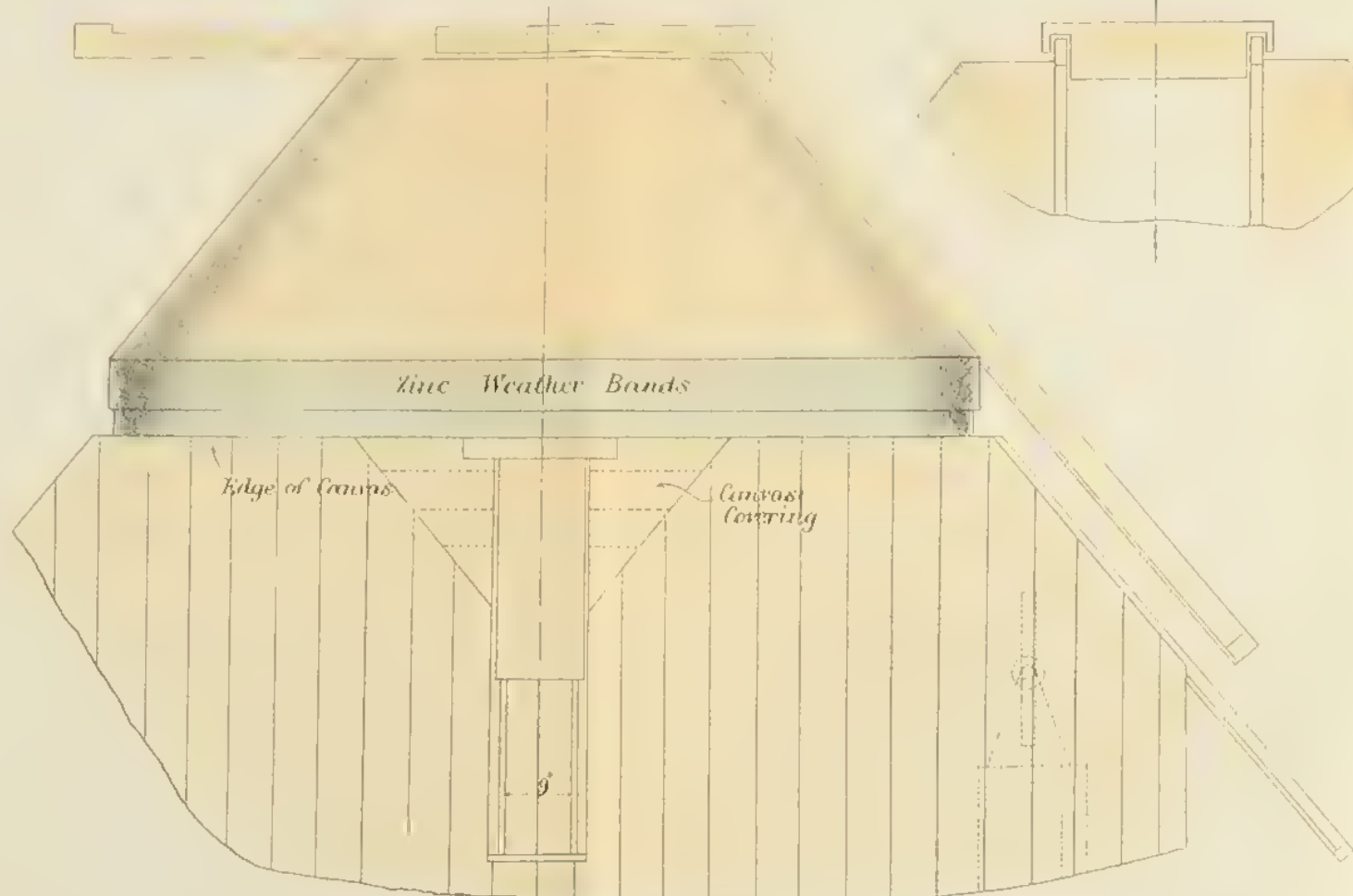

FRONT VIEW OF TRANSIT SHUTTER. SIDE VIEW OF SHUTTER SLIDES.

F.

ELEVATION OF END OF TOP SHUTTER, Made to lap over Dome Shutter

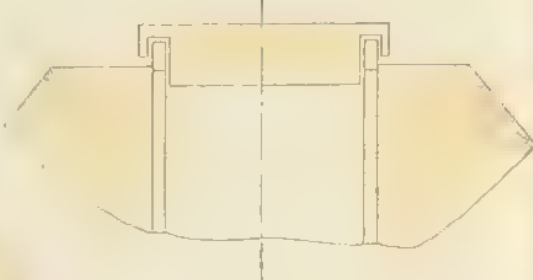

D.

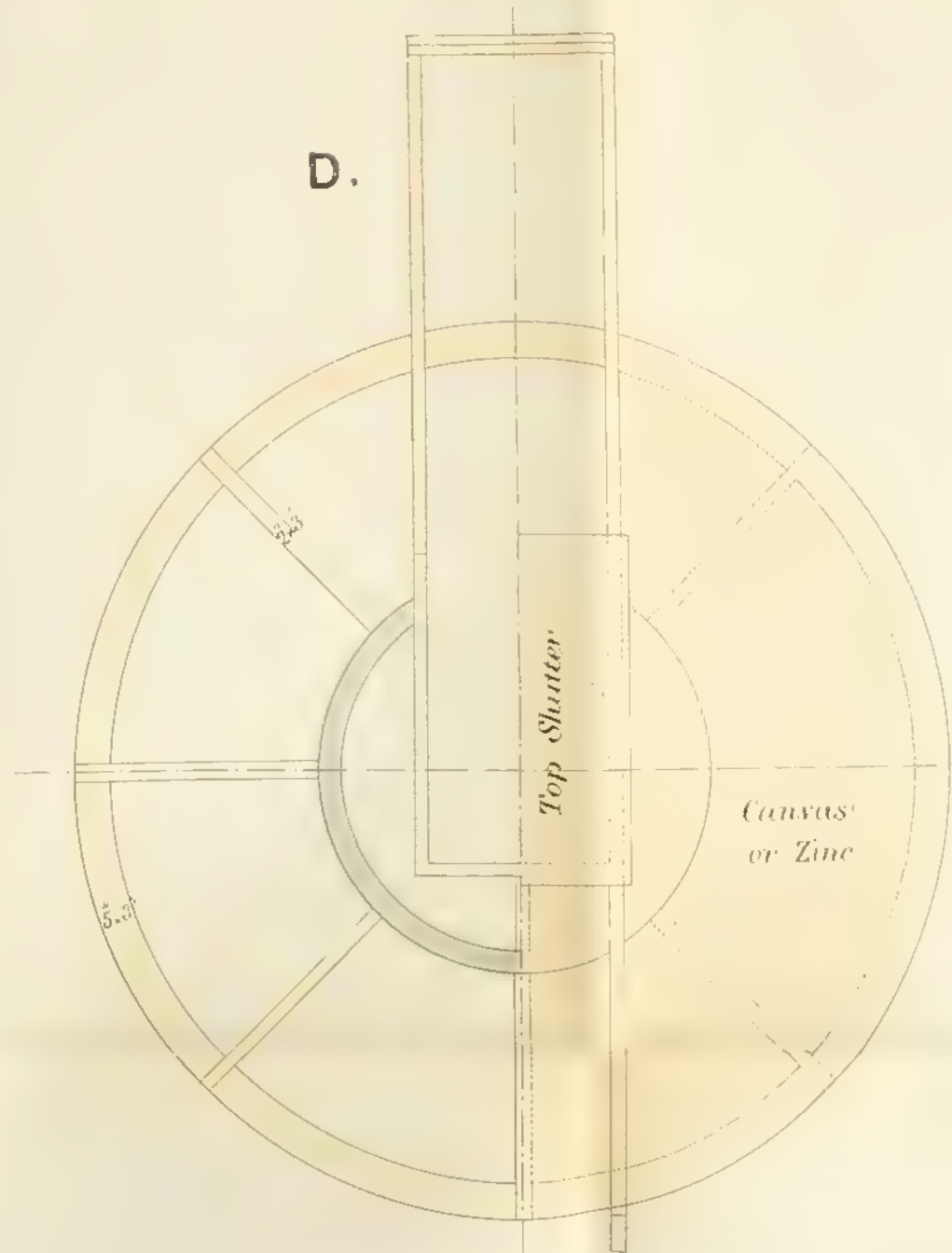

PLAN OF TOP OF DOME.

E.

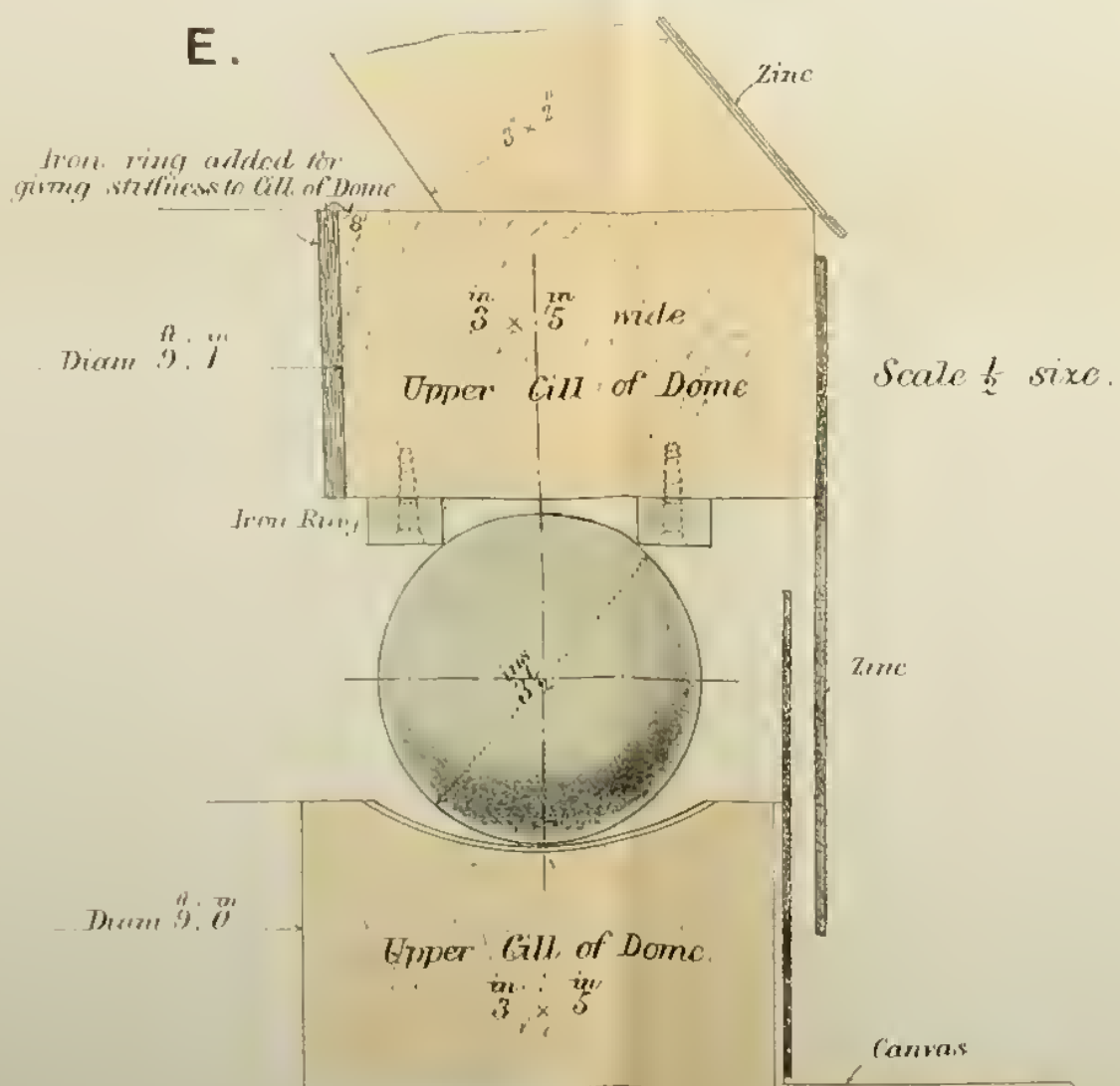

SECTION OF DOME CILLS, Showing Travelling Ball.

Top Plate of Building.

Boarding 7/8 x 3/4

G.

SECTION THROUGH TRANSIT SHUTTER.

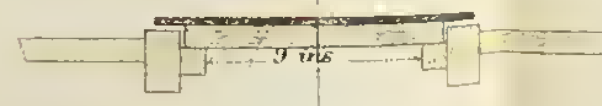

Scale 1/2 in to a foot.

H.

SECTION THROUGH DOME SHUTTER

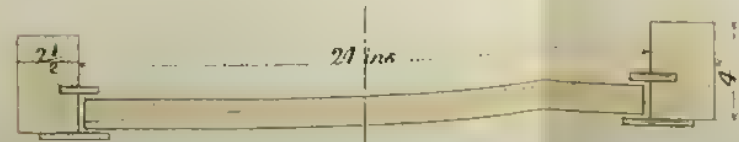

DESIGN FOR A "ROMSEY" OBSERVATORY FOR A 6 FT TELESCOPE AND A TRANSIT INSTRUMENT.

Scale 1/2 Inch to 1 Foot

A.

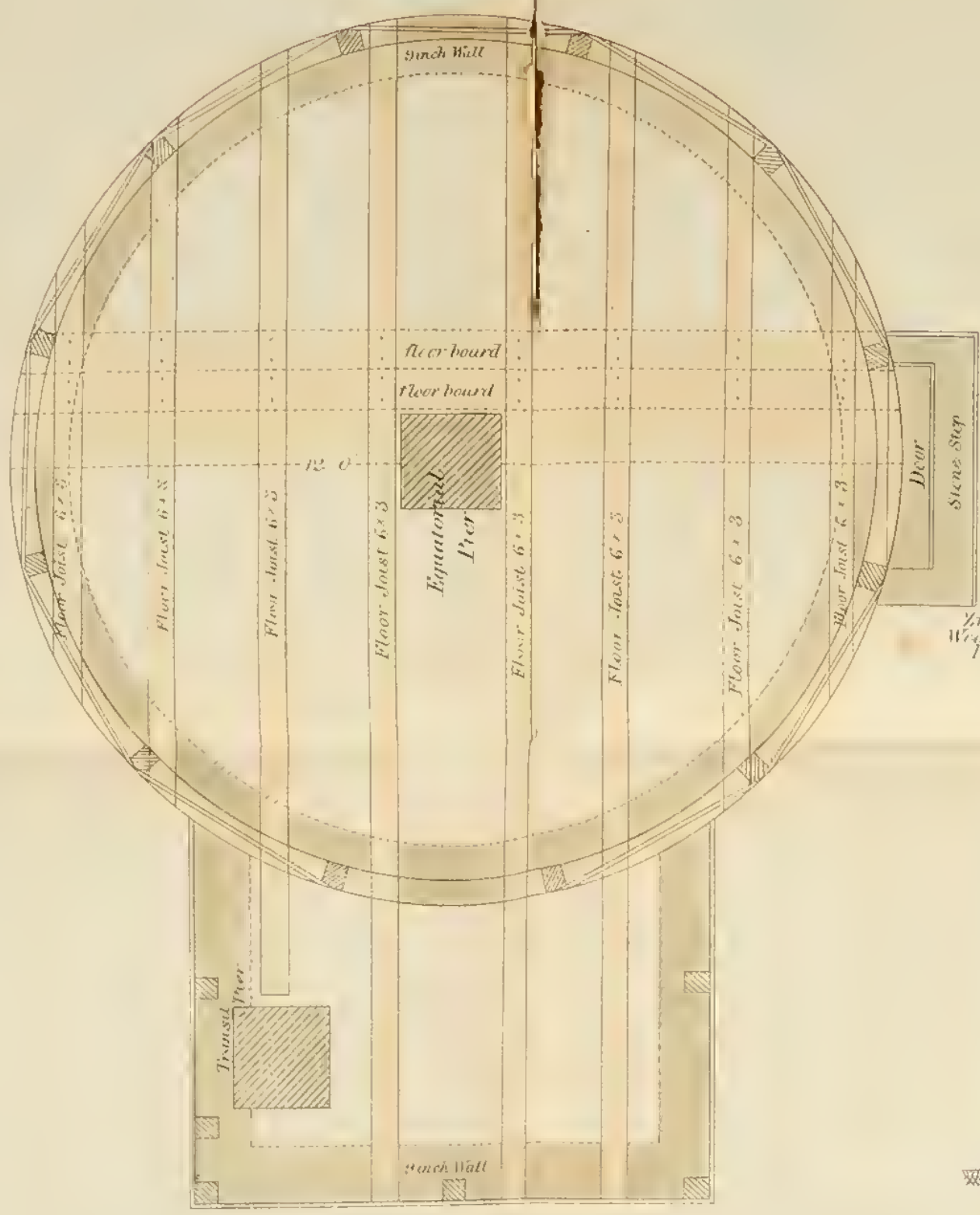

PLAN.

B.

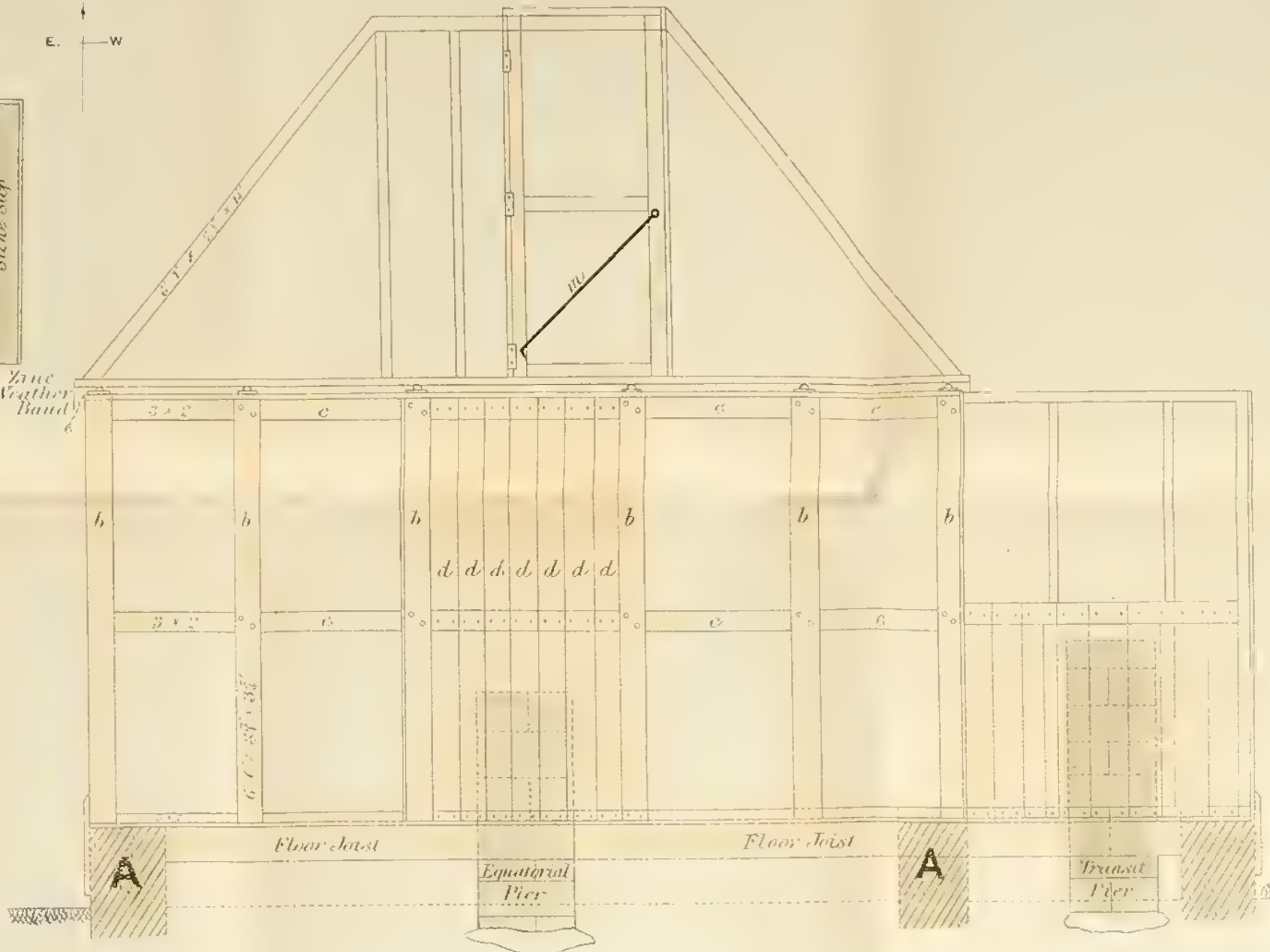

SOUTH ELEVATION.

C.

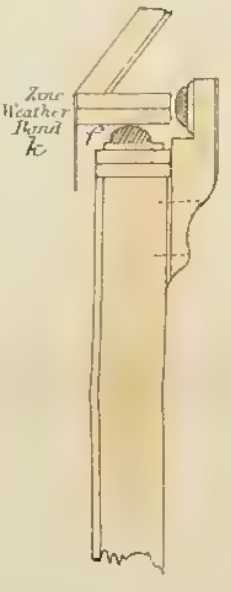

SECTION OF DOME GILL.

D.

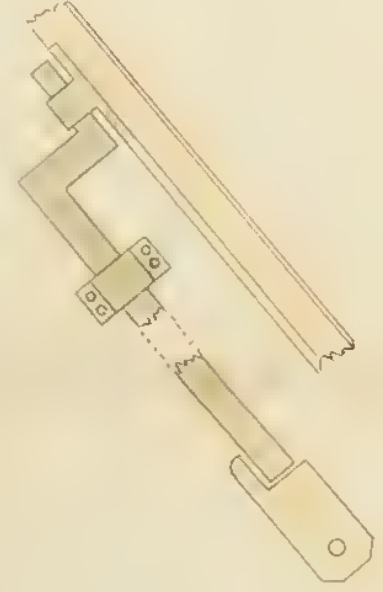

SHUTTER FASTENER.

E.

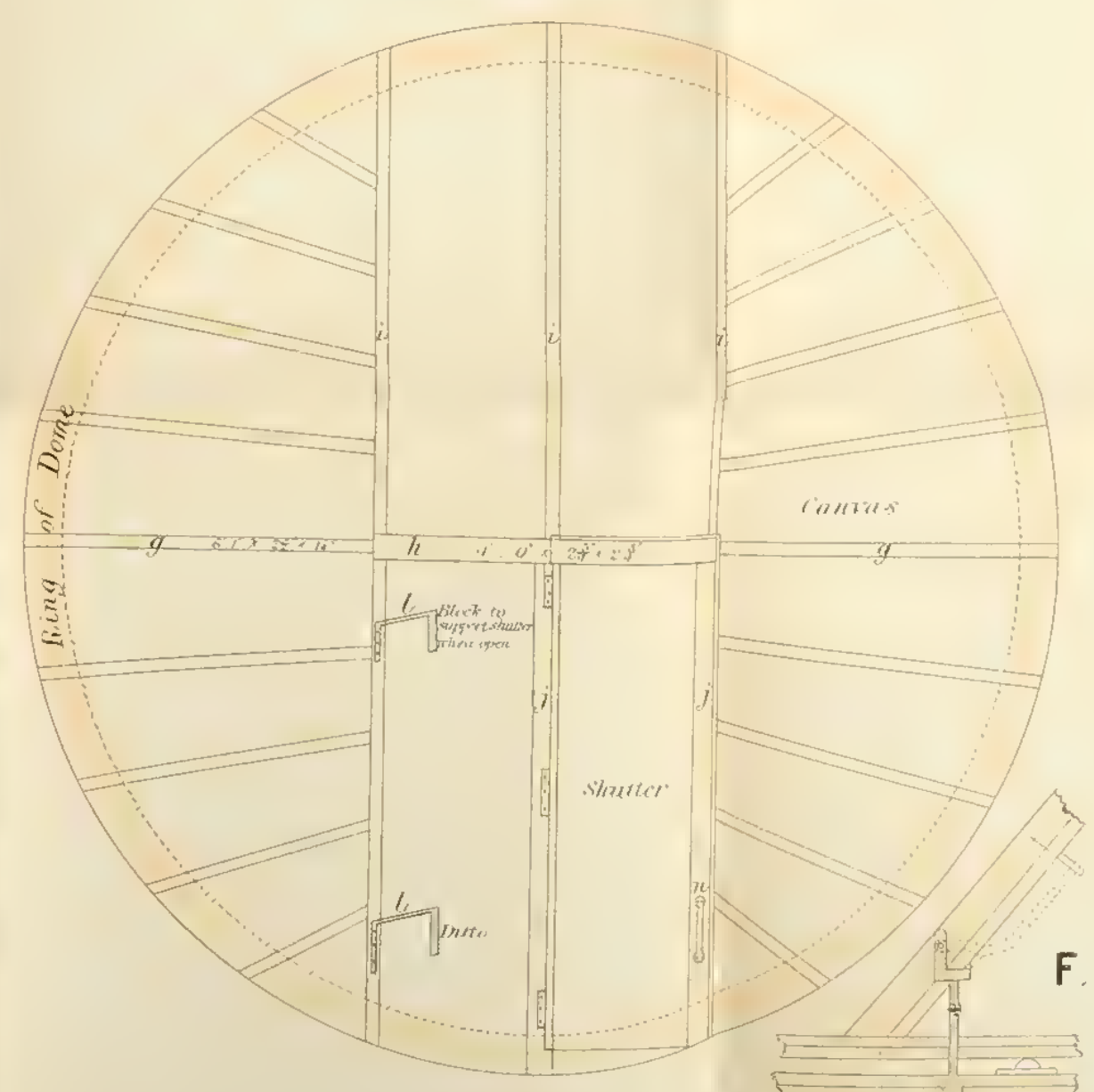

PLAN OF TOP OF DOME.

F.

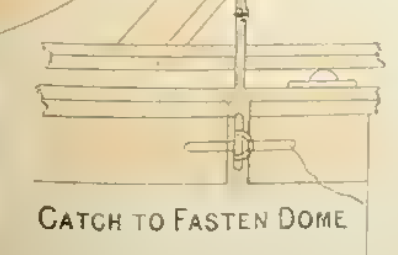

CATCH TO FASTEN DOME.

G.

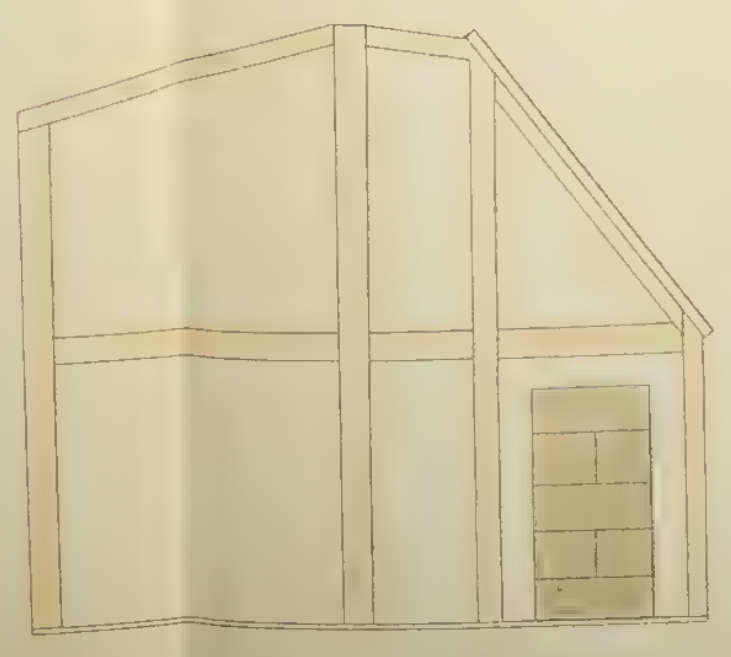

EAST ELEVATION OF TRANSIT ROOM.
(Boards removed)



GETTY CENTER LIBRARY



3 3125 00139 6171

