



**Calhoun: The NPS Institutional Archive**  
**DSpace Repository**

---

Theses and Dissertations

1. Thesis and Dissertation Collection, all items

---

2003-06

# Joint fires network ISR interoperability requirements within a joint force architecture

Corsano, Scott E.

Monterey, California. Naval Postgraduate School

---

*Downloaded from NPS Archive: Calhoun*



Calhoun is a project of the Dudley Knox Library at NPS, furthering the precepts and goals of open government and government transparency. All information contained herein has been approved for release by the NPS Public Affairs Officer.

**Dudley Knox Library / Naval Postgraduate School**  
**411 Dyer Road / 1 University Circle**  
**Monterey, California USA 93943**

<http://www.nps.edu/library>

# NAVAL POSTGRADUATE SCHOOL

## Monterey, California



## THESIS

**JOINT FIRES NETWORK ISR INTEROPERABILITY  
REQUIREMENTS WITHIN A JOINT FORCE  
ARCHITECTURE**

by

Scott Edmund Corsano

June 2003

Thesis Advisor:

William G. Kemple

Thesis Co-Advisor:

John S. Osmundson

**Approved for public release; distribution is unlimited.**

THIS PAGE INTENTIONALLY LEFT BLANK

REPORT DOCUMENTATION PAGE			Form Approved OMB No. 0704-0188	
Public reporting burden for this collection of information is estimated to average 1 hour per response, including the time for reviewing instruction, searching existing data sources, gathering and maintaining the data needed, and completing and reviewing the collection of information. Send comments regarding this burden estimate or any other aspect of this collection of information, including suggestions for reducing this burden, to Washington headquarters Services, Directorate for Information Operations and Reports, 1215 Jefferson Davis Highway, Suite 1204, Arlington, VA 22202-4302, and to the Office of Management and Budget, Paperwork Reduction Project (0704-0188) Washington DC 20503.				
<b>1. AGENCY USE ONLY (Leave blank)</b>		<b>2. REPORT DATE</b> June 2003	<b>3. REPORT TYPE AND DATES COVERED</b> Master's Thesis	
<b>4. TITLE AND SUBTITLE:</b> Title (Mix case letters) Joint Fires Network ISR Interoperability Requirements Within a Joint Force Architecture			<b>5. FUNDING NUMBERS</b>	
<b>6. AUTHOR(S)</b> Corsano, Scott Edmund				
<b>7. PERFORMING ORGANIZATION NAME(S) AND ADDRESS(ES)</b> Naval Postgraduate School Monterey, CA 93943-5000			<b>8. PERFORMING ORGANIZATION REPORT NUMBER</b>	
<b>9. SPONSORING /MONITORING AGENCY NAME(S) AND ADDRESS(ES)</b> N/A			<b>10. SPONSORING/MONITORING AGENCY REPORT NUMBER</b>	
<b>11. SUPPLEMENTARY NOTES</b> The views expressed in this thesis are those of the author and do not reflect the official policy or position of the Department of Defense or the U.S. Government.				
<b>12a. DISTRIBUTION / AVAILABILITY STATEMENT</b> Approved for public release; distribution is unlimited.			<b>12b. DISTRIBUTION CODE</b>	
<b>13. ABSTRACT (maximum 200 words)</b>  The Navy is aggressively pursuing a capability for Fleet units to combine intelligence information into one common picture to allow for rapid correlation of multiple pieces of intelligence. This capability would contribute significantly to reducing the "sensor-to-shooter" timeline and significantly increase the likelihood of correctly classifying and striking a contact of interest. This capability comes in the form of a program called Joint Fires Network (JFN) and the concept was forged through several Fleet Battle Experiments (FBEs) as well as lessons learned from the Persian Gulf War. The objective of this thesis is to examine JFN within the Department of Defense's ISR architecture of the future. It will look at what is envisioned for the future of DoD's ISR systems and how well JFN will function as both a customer and provider of ISR information within a Joint Force architecture. This thesis uses the ISR Integrated Capstone Strategic Plan (ISR-ICSP) developed by the Assistant Secretary of Defense for Command, Control, Communications and Intelligence (C3I) as the foundation for what DoD's ISR architecture of the future will look like. This thesis looks at the Operational and System Level Architectures spelled out in this document and examines the Navy's stated requirements and existing programs which comprise JFN. This thesis also looks at the ISR systems which each service is planning for the future and how well JFN will share ISR information with these systems.				
<b>14. SUBJECT TERMS</b> Joint Fires Network; JFN; Interoperability; Intelligence, Surveillance, and Reconnaissance; ISR; DCGS; DCGS-N; Distributed Common Ground/Surface System; Distributed Common Ground/Surface System-Navy; Naval Fires Network; NFN.			<b>15. NUMBER OF PAGES</b> 103	
			<b>16. PRICE CODE</b>	
<b>17. SECURITY CLASSIFICATION OF REPORT</b> Unclassified	<b>18. SECURITY CLASSIFICATION OF THIS PAGE</b> Unclassified	<b>19. SECURITY CLASSIFICATION OF ABSTRACT</b> Unclassified	<b>20. LIMITATION OF ABSTRACT</b> UL	

THIS PAGE INTENTIONALLY LEFT BLANK

**Approved for public release; distribution is unlimited.**

**JOINT FIRES NETWORK ISR INTEROPERABILITY REQUIREMENTS  
WITHIN A JOINT FORCE ARCHITECTURE**

Scott E. Corsano  
Lieutenant Commander, United States Navy  
B.S., Massachusetts Maritime Academy, 1987

Submitted in partial fulfillment of the  
requirements for the degree of

**MASTER OF SCIENCE IN SYSTEMS TECHNOLOGY**

from the

**NAVAL POSTGRADUATE SCHOOL  
June 2003**

Author: Scott E. Corsano

Approved by: William G. Kemple  
Thesis Advisor

John S. Osmundson  
Co-Advisor

Dan C. Boger  
Chairman, Department of Information Sciences

THIS PAGE INTENTIONALLY LEFT BLANK

## **ABSTRACT**

The Navy is aggressively pursuing a capability for Fleet units to combine intelligence information into one common picture to allow for rapid correlation of multiple pieces of intelligence. This capability would contribute significantly to reducing the “sensor-to-shooter” timeline and significantly increase the likelihood of correctly classifying and striking a contact of interest. This capability comes in the form of a program called Joint Fires Network (JFN) and the concept was forged through several Fleet Battle Experiments (FBEs) as well as lessons learned from the first Persian Gulf War. The objective of this thesis is to examine JFN within the Department of Defense’s ISR architecture of the future. It will look at what is envisioned for the future of DoD’s ISR systems and how well JFN will function as both a customer and provider of ISR information within a Joint Force architecture. This thesis uses the ISR Integrated Capstone Strategic Plan (ISR-ICSP) developed by the Assistant Secretary of Defense for Command, Control, Communications and Intelligence (C3I) as the foundation for what DoD’s ISR architecture of the future will look like. This thesis looks at the Operational and System Level Architectures spelled out in this document and examines the Navy’s stated requirements and existing programs which comprise JFN. This thesis also looks at the ISR systems which each service is planning for the future and how well JFN will share ISR information with these systems.



THIS PAGE INTENTIONALLY LEFT BLANK

# TABLE OF CONTENTS

<b>I.</b>	<b>INTRODUCTION.....</b>	<b>1</b>
<b>A.</b>	<b>HISTORY .....</b>	<b>1</b>
<b>B.</b>	<b>OBJECTIVE .....</b>	<b>4</b>
<b>C.</b>	<b>SCOPE AND METHODOLOGY .....</b>	<b>5</b>
<b>1.</b>	<b>Primary Research Question .....</b>	<b>5</b>
<b>2.</b>	<b>Secondary Research Question .....</b>	<b>5</b>
<b>D.</b>	<b>CHAPTER OUTLINE.....</b>	<b>5</b>
<b>II.</b>	<b>DOD’S ISR VISION .....</b>	<b>7</b>
<b>A.</b>	<b>DOD ISR-ICSP.....</b>	<b>8</b>
<b>B.</b>	<b>DOD DCGS CRD.....</b>	<b>14</b>
<b>C.</b>	<b>DRAFT DOD DCGS JOINT OPERATIONAL CONCEPT .....</b>	<b>18</b>
<b>D.</b>	<b>CHAPTER SUMMARY.....</b>	<b>25</b>
<b>III.</b>	<b>THE FUTURE OF ISR SYSTEMS.....</b>	<b>29</b>
<b>A.</b>	<b>JITC .....</b>	<b>29</b>
<b>B.</b>	<b>AIR FORCE ISR.....</b>	<b>30</b>
<b>1.</b>	<b>DCGS Integration Backbone .....</b>	<b>33</b>
<b>2.</b>	<b>Backbone Interoperability .....</b>	<b>36</b>
<b>3.</b>	<b>GAO DCGS Findings .....</b>	<b>37</b>
<b>C.</b>	<b>ARMY ISR .....</b>	<b>38</b>
<b>D.</b>	<b>MARINE CORPS ISR.....</b>	<b>41</b>
<b>E.</b>	<b>CHAPTER SUMMARY.....</b>	<b>44</b>
<b>IV.</b>	<b>JFN DESCRIPTION .....</b>	<b>45</b>
<b>A.</b>	<b>GLOBAL COMMAND AND CONTROL SYSTEM – MARITIME .....</b>	<b>46</b>
<b>B.</b>	<b>JOINT SERVICE IMAGERY PROCESSING SYSTEM – NAVY.....</b>	<b>48</b>
<b>C.</b>	<b>TACTICAL EXPLOITATION SYSTEM – NAVY .....</b>	<b>49</b>
<b>D.</b>	<b>TIME CRITICAL TARGETING .....</b>	<b>52</b>
<b>E.</b>	<b>JFN ISR CAPABILITIES.....</b>	<b>58</b>
<b>1.</b>	<b>Imagery .....</b>	<b>58</b>
<b>2.</b>	<b>JSTARS.....</b>	<b>60</b>
<b>3.</b>	<b>ELINT .....</b>	<b>61</b>
<b>4.</b>	<b>TES-N Integrated Tactical Display .....</b>	<b>62</b>
<b>5.</b>	<b>Multi-Service Operations .....</b>	<b>64</b>
<b>F.</b>	<b>JFN ROADMAP .....</b>	<b>66</b>
<b>G.</b>	<b>JFN REQUIREMENTS .....</b>	<b>70</b>
<b>1.</b>	<b>NFN MNS .....</b>	<b>70</b>
<b>2.</b>	<b>DCGS-N TRD.....</b>	<b>71</b>
<b>H.</b>	<b>JFN TODAY.....</b>	<b>73</b>
<b>I.</b>	<b>CHAPTER SUMMARY.....</b>	<b>74</b>
<b>V.</b>	<b>SUMMARY/CONCLUSIONS.....</b>	<b>77</b>

<b>A. SUMMARY .....</b>	<b>77</b>
<b>B. CONCLUSIONS .....</b>	<b>80</b>
<b>ACRONYMS .....</b>	<b>83</b>
<b>INITIAL DISTRIBUTION LIST .....</b>	<b>87</b>

## LIST OF FIGURES

Figure 1.	DoD ISR Vision 21 .....	10
Figure 2.	DoD ISR Vision 21 Operational Concept.....	13
Figure 3.	DoD DCGS Concept.....	15
Figure 4.	DoD DCGS High-level Operational Concept (OV-1) .....	17
Figure 5.	DCGS Migration Path.....	21
Figure 6.	Standing Joint Force Headquarters – The Goal .....	23
Figure 7.	DCGS Integrated Strategy to Achieve the Vision .....	25
Figure 8.	DCGS Integration Backbone .....	34
Figure 9.	DCGS Integrated Backbone Layers.....	35
Figure 10.	Objective Force Operational Concept.....	39
Figure 12.	GCCS-M Notional Force-Level Schematic .....	46
Figure 13.	JSIPS-N Version 3.1/3.2 Architecture .....	48
Figure 14.	Full TES-N Architecture.....	50
Figure 15.	Intelligence Cycle .....	52
Figure 16.	Targeting Cycle.....	53
Figure 17.	Intelligence Support to the Targeting Cycle .....	54
Figure 18.	Time Critical Strike Targeting Cycle.....	54
Figure 19.	Time Critical Strike Cycle Overlaid onto the Targeting Process.....	55
Figure 20.	JFN Sensor Inputs .....	58
Figure 21.	JSIPS-N Architecture.....	60
Figure 22.	GSD Tactical Symbology .....	62
Figure 23.	Cross-INT Overlays .....	63
Figure 24.	NFN Architecture Functional Overlaps .....	67
Figure 25.	TES/JFN Spiral Development Plan .....	69
Figure 26.	JFN Converged Architecture .....	69

THIS PAGE INTENTIONALLY LEFT BLANK

## LIST OF TABLES

Table 1.	JFN Program Responsibilities.....	4
Table 2.	DCGS Council Members .....	8
Table 3.	DCGS Baseline Systems.....	16
Table 4.	DCGS Capabilities Summary .....	27
Table 5.	Block 10.2 Multi-INT Core Required Collectors .....	32
Table 6.	Block 10.2 Multi-INT Core TPED Interoperability Requirements .....	32
Table 7.	DCGS Backbone C2 System Interoperability Requirements .....	33
Table 8.	Full TES-N vs RTC Capabilities Comparison.....	51
Table 9.	JFN Component Support to Time Critical Targeting .....	57
Table 10.	DCGS Capabilities Summary .....	80

THIS PAGE INTENTIONALLY LEFT BLANK

## EXECUTIVE SUMMARY

The Department of Defense (DoD) has provided guidance to the services regarding the capabilities necessary for the ISR systems of the future. The Distributed Common Ground/Surface System (DCGS) represents DoD's strategy for how to achieve fully interoperable ISR systems as well as an architecture of how it will look. DCGS creates an umbrella program which covers all processing, exploitation, and dissemination capabilities required for the future. The vision and operational concept for DCGS is codified in the ISR Integrated Capstone Requirements Strategic Plan (ISR-ICSP) which provides an integration roadmap intended to guide long-range planning and program procurement.

The ISR-ICSP identifies ISR architecture needs of the future which include “dynamic control of theater sensors and platforms; real-time visualization of ISR battlespace information; decision aids supporting ISR information; and collaborative command and control features.” In order to obtain these capabilities, DoD's ISR Vision 21 requires ISR community integration with the Global Information Grid (GIG); cross-domain integration to eliminate ISR system stovepipes; integration of all available ISR information with a common operational picture (COP); integration of ISR with real-time operations; and multi-INT collaboration which provides near real-time TPED to national, theater, and tactical levels.

The future of ISR is going to challenge our intelligence systems in ways never before considered: allowing one service to control another service's sensor/platform; posting information to a global information grid before it has been processed; making information available before a decision maker knows he/she needs it. These concepts, which in the past would never have been considered because of procedure or system limitations, will surely guide our ISR systems of the future.

JFN has proven a certain level of interoperability with the other services, before the converged architecture. As the JFN system continues to evolve, its interoperability with the other services and its contribution to time critical targeting will continue to improve.



THIS PAGE INTENTIONALLY LEFT BLANK

# I. INTRODUCTION

## A. HISTORY

The Navy is aggressively pursuing a capability for Fleet units to combine intelligence information into one common picture to allow for a more complete picture of the battlespace. This capability would contribute significantly to reducing the “sensor-to-shooter” timeline and significantly increase the likelihood of rapidly and correctly classifying and striking a contact of interest, particularly mobile targets. This capability comes in the form of a program called Joint Fires Network (JFN). The JFN concept was forged through several Fleet Battle Experiments (FBEs) as well as lessons learned from the 1991 Persian Gulf War.

In 1995, the Army Space Program Office (ASPO) began an effort to consolidate the Army’s National Imagery, Theater Imagery and National Signals Intelligence (SIGINT) programs into a single multiple intelligence (multi-INT) system. This was a classified program, which developed the Tactical Exploitation System (TES) which was first delivered in 1998.<sup>1</sup>

In 1996, the Joint Service Imagery Processing System- Navy (JSIPS-N) program office was looking to develop a system to handle receipt and processing of tactical imagery. They developed the Tactical Input Segment (TIS) for this role. TES was considered at the time, but rejected because there were no existing requirements for a multi-INT system.<sup>2</sup>

In 1997, Chief of Naval Operations (OPNAV) directorates N86 (now N76) and N24 began the Tactical Real-Time Targeting System (TARTS) program to address land attack targeting from surface ships (particularly DD 21). TARTS utilized the Army developed TES system as its baseline. This same year, the Naval Reserves and OPNAV N6B purchased a copy of the Army’s TES system, modified the system to monitor harbors, and named it Littoral Surveillance System (LSS). The Navy also added multi-INT networking and Moving Target Indicator (MTI) exploitation to the LSS system.<sup>3</sup>

During FBEs conducted between 1998-2000, a need was identified to network sensors and decision makers together to allow for rapid prosecution of time critical targets.<sup>4</sup> A time

---

<sup>1</sup> JFN Virtual Program Office. NFN Read Ahead for N76, information paper developed for N76. 16 October 2002. p. 1.

<sup>2</sup> Ibid.

<sup>3</sup> Ibid

<sup>4</sup> Ibid.

critical target is one in which the time available to affect that target from the time which it is detected is extremely limited.

In 2000, CINCLANTFLT identified the immediate, high priority need to develop a naval fires network that would provide network-centric capability to support Joint, Allied, and Coalition forces in the engagement of time critical targets. At that time, the existing “best of breed” systems were combined into a program called Naval Fires Network (NFN), to provide this capability to the fleet as quickly as possible and capitalize on existing technology and systems. The three systems were:

- Global Command and Control System- Maritime (GCCS-M)
- Joint Service Imagery Processing System- Navy (JSIPS-N)
- Tactical Exploitation System- Navy (TES-N)

Among other things, each of these elements provided an initial level of interoperability with systems from each of the other services.<sup>5</sup>

During FBE India in 2001, an NFN prototype successfully demonstrated the ability to reduce the sensor to shooter timeline to less than 20 minutes. Based upon this demonstration, Commander, Third Fleet (COMTHIRDFLT) recommended immediate deployment of NFN aboard USS JOHN C. STENNIS (CVN 74) and USS ABRAHAM LINCOLN (CVN 72), with COMNAVAIRPAC citing NFN as a “critical capability.”<sup>6</sup>

On 16 July 2001, the Acting Assistant Secretary of the Navy for Research, Development and Acquisition (ASN(RD&A)) established a new direct reporting position titled Program Director (PD) for Time Critical Strike/Naval Fires Network. The Program Managers for each of the component systems that comprised NFN now reported to this new PD for the purpose of coordinating NFN activities and initiatives. This included: PMA-281 (JSIPS-N program manager under NAVAIR); PMS-454 (TES-N program manager under NAVSEA); and PMW-157 (GCCS program manager under SPAWAR). The new PD developed a “Virtual Program Office” (VPO) made up of representatives from each of the original program offices, as well as the appropriate OPNAV, SECNAV, and Fleet Staffs.<sup>7</sup>

---

<sup>5</sup> Ibid.

<sup>6</sup> Ibid.

<sup>7</sup> Ibid.

The Virtual Program Office was charged with coordinating activities of program managers in the three SYSCOMs, and with converging the NFN systems architecture through successive fielding events (spirals), each accompanied by a corresponding evolution in CONOPs.<sup>8</sup>

After the terrorist attacks of 11 September 2001, Congress passed legislation which made Defense Emergency Response Funding (DERF) available. The Navy utilized DERF to rapidly deploy NFN capability in the form of TES-N installations and system upgrades to JSIPS-N, GCCS-M, and existing communication systems.<sup>9</sup>

On 19 October 2001, the Director of Surface Warfare (OPNAV N76) was designated the lead Resource Sponsor for the overall NFN effort, with responsibility to coordinate all time critical strike related fleet requirements and resources across resource sponsors.<sup>10</sup>

In February 2002, the Chief of Naval Operations (CNO) approved the NFN Mission Need Statement (MNS) previously submitted by Commander, Atlantic Fleet (COMLANTFLT).<sup>11</sup>

In January 2003, the name of the program was changed to Joint Fires Network (JFN) to reflect its wider acceptance as more than just a naval fires system. Also, the Virtual Program Office was recently eliminated. Table 1 identifies the organizations currently involved in both resource sponsorship and program management of JFN. Organizational changes and discussion are currently ongoing regarding the organization of the program now that the VPO was eliminated and further details were not available at the time of this writing.

---

<sup>8</sup> Ibid, p. 2.

<sup>9</sup> JFN Virtual Program Office. NFN Read Ahead. p. 2

<sup>10</sup> Ibid.

<sup>11</sup> Ibid. p. 3

---

**Resource Sponsors**

<i>N61</i>	<i>PROGRAM RESOURCE SPONSOR</i> Resource Sponsor for JFN Requirements/Resources Resource Sponsor for GCCS-M program Resource Sponsor for JFN communications Resource Sponsor for TES-N program Resource Sponsor for JSIPS-N program OPNAV lead for Fleet JFN Requirements
<i>N20</i>	<i>OPNAV lead for ISR requirements</i> Lead for JFN manning, training requirements

**Program Management**

<i>NAVAIR/PMA-281</i>	<i>JFN REQUIREMENTS LEAD</i> Lead for Fleet Survey of TCS needs and NAT IPT requirements Execution of JSIPS-N program
<i>SPAWAR/PEO C4I</i>	<i>JFN CHIEF ENGINEER</i> Lead Non-Recurring Engineering (NRE) for Spiral 1B and Spiral 2 Lead for testing/Fleet acceptance of new JFN spirals Lead JFN Sustained Engineering Team to develop future Spirals Lead interface with Chief Engineer of the Navy (ASN/CHENG) Lead interface with CDL-N programs Lead for emergency deployment communications plan
<i>NAVSEA/IWS 6C</i>	<i>JFN INSTALLATIONS/EXECUTION LEAD</i> Coordinate installations/upgrades for all JFN Systems Lead JFN acquisition strategy Execution of TES-N program
<i>PMW-157</i>	Lead for coordinating GCCS-M install schedule with other systems Lead for ensuring Joint GCCS-M interoperability preserved Execution of GCCS-M program
<i>Associated Offices:</i>	
<i>NSWC</i>	Lead for JFN Analysis of Alternatives and continuing independent analysis support
<i>NWDC</i>	Lead JFN experimentation/analysis in MC-02; JFN TACMEMO

---

**Table 1. JFN Program Responsibilities<sup>12</sup>****B. OBJECTIVE**

The objective of this thesis is to examine JFN within the Department of Defense's (DoD's) Intelligence, Surveillance, and Reconnaissance (ISR) architecture of the future. It will look at what is envisioned for the future of DoD's ISR systems and how well JFN will be able to share ISR information within a Joint Force architecture. However, for purposes of narrowing the scope of the thesis, it will not look at the vital engagement capabilities which JFN is envisioned to have in the future. Existing Navy systems were brought together to test the JFN concept and

---

<sup>12</sup> JFN Virtual Program Office. White Paper on Naval Fires Network, information paper developed for ASN (RD&A). p. 6.

provide the capability to the fleet as quickly as possible. However, to fully realize the potential effectiveness of this system, JFN must be capable of functioning within a joint architecture made up of many other ISR, command & control, and weapon systems. With each service embarking on new, unprecedented levels of networked information, JFN must be poised to take advantage of any and all available information and to share its information with others.

### **C. SCOPE AND METHODOLOGY**

In this thesis, I will use the ISR Integrated Capstone Strategic Plan (ISR-ICSP) developed by the Assistant Secretary of Defense (ASD) for Command, Control, Communications and Intelligence (C3I) as the foundation for what DoD's ISR architecture of the future will look like. I will look at the Operational and System Level Architectures as envisioned. I will then look at the ISR systems which each service is planning for the future and how well JFN will share ISR information with these systems. From this analysis, I will develop recommendations for the future of JFN, either in capability or doctrine, to ensure the system is able to properly utilize available ISR information for prosecution of time critical targets and be able to serve as the Navy's DCGS component, providing ISR information to other services.

#### **1. Primary Research Question**

Given DoD's view of an overarching Distributed Common Ground/Surface System (DCGS) architecture discussed in Chapter II and the ISR systems of each of the services, will JFN be able to properly share and exploit all ISR information available within a Joint Force architecture in order to support time critical targeting?

#### **2. Secondary Research Question**

Are there additional capabilities which must be stated in the requirements for JFN to ensure its ability to rapidly prosecute time critical targets?

### **D. CHAPTER OUTLINE**

Chapter II will review DoD's operational view of the ISR architecture of the future. Chapter III will examine each service's system level plan for ISR systems of the future. Chapter IV will review the current and projected JFN architectures and will assess how well JFN will

fulfill the stated and implied ISR interoperability requirements. Chapter V will provide final recommendations and conclusions.

## II. DOD'S ISR VISION

The Joint Fires Network (JFN) system was rapidly fielded using existing Navy programs. As such, although a definite need has been identified for the capabilities which JFN provides, the formal definition of requirements is still catching up with the system. This chapter will review guidance provided by DoD regarding the vision of ISR information networks of the future.

The Department of Defense has developed the Distributed Common Ground/Surface System (DCGS). DCGS is both a strategy for achieving a series of interoperable systems and the desired end state or the series of interoperable systems themselves. The DCGS program was established in FY '96 as an umbrella program element. Contained within this funding element are imagery intelligence (IMINT), signals intelligence (SIGINT), and measurement and signature intelligence (MASINT). DCGS responds to the need to create an umbrella program that covers all airborne processing, exploitation and dissemination (PED) capabilities and corrects the deficiencies identified during DESERT STORM, where multiple systems were unable to pass or share information.<sup>13</sup>

DCGS is a Deputy Assistant Secretary of Defense (DASD) C3ISR & Space sponsored initiative to guide a series of interrelated service and DoD agency programs to achieve interoperable multi-INT ISR processing & exploitation capability. Under the umbrella concept, each of the services will field ISR capabilities tailored to their service mission which will be interoperable with the Joint ISR architecture.<sup>14</sup>

DoD formed an organization to lead the way ahead for the services on ISR integration. This body is the DCGS Oversight Council (Table 2) with its related working group level IPTs. The council is responsible for guiding the implementation of the Office of the Secretary of Defense's vision of a multi-intelligence, multi-platform, Tasking, Processing, Exploitation, and Dissemination (TPED) architecture for DoD ISR collection systems.<sup>15</sup>

---

<sup>13</sup> Distributed Common Ground System Infrastructure IPT Website. [[www.dcgsonline.com](http://www.dcgsonline.com)]. April 2003.

<sup>14</sup> Ibid.

<sup>15</sup> Deputy Assistant Secretary of Defense (C3ISR & Space). DCGS IPT Charter. 18 May 2001.



---

<i>Joint Chiefs of Staff</i>	JCS, J2, and J8
<i>United States Joint Forces Command</i>	USJFCOM J2, J3, J8
<i>Army</i>	DAPRO-FDI
<i>Marine Corps</i>	USMC C4I
<i>Navy</i>	OPNAV N20
<i>Air Force</i>	USAF/XOIR
<i>DCGS Infrastructure IPT Lead</i>	SAF/AQIC
<i>DCGS IMINT IPT Lead</i>	NIMA/ATSO
<i>DCGS MASINT IPT Lead</i>	CMO CMX
<i>DCGS SIGINT IPT Lead</i>	NSA/NTIO
<i>DCGS Test &amp; Evaluation IPT Lead</i>	JITC

---

**Table 2. DCGS Council Members<sup>16</sup>**

**A. DOD ISR-ICSP**

DoD has codified its vision for the future of ISR in a document called the Intelligence, Surveillance, and Reconnaissance Integrated Capstone Strategic Plan (ISR-ICSP). This document develops a vision and an operational concept for ISR based upon strategic guidance and future mission needs. It identifies current ISR capabilities and new opportunities to meet these needs. From this assessment, the ISR-ICSP develops goals, objectives, and strategic actions necessary to attain the vision. Finally, the plan identifies an integration roadmap intended to guide long-range planning and program procurement.<sup>17</sup>

The ISR-ICSP identified four key limitations that existed within the existing structure:<sup>18</sup>

- An integrated set of Joint, all-source information requirements is not available for strategic planning;
- An investment strategy to build an executable integrated ISR plan has not been formulated;
- There is no ISR systems architect and no overarching multi-INT architecture to satisfy user information needs cost effectively; and

---

<sup>16</sup> Ibid.

<sup>17</sup> Assistant Secretary of Defense for Command, Control, Communications, and Intelligence (ASD-C3I). *Intelligence, Surveillance, and Reconnaissance Integrated Capstone Strategic Plan (ISR-ICSP)*. Version 1.0. 3 November 2000. p. 1.

<sup>18</sup> Ibid. p. 1.

- The Defense and Intelligence Communities lack integrated modeling and simulation tools necessary to evaluate overall intelligence value or military worth of ISR assets.

The ISR-ICSP also mentions guidance provided in the Defense Planning Guidance Update 2001 – 2005 which presents four challenges to achieving information superiority which bear directly on ISR:<sup>19</sup>

- Information transport and processing – making information available in a timely manner;
- Battlespace awareness – providing better battlespace awareness to commanders in the field and making that information readily usable for mission planning and execution;
- Information Operations (IO) – developing IO strategies and capabilities and fully integrating IO into military operations; and
- Information Assurance – ensuring reliability, accuracy, and confidentiality of information.

The ISR-ICSP spells out that in order to fight effectively in the future, DoD's ISR capabilities will need to be melded into a system of systems that ties national, theater, and tactical sensors, platforms, producers of information, commanders, planners, and shooters together in one global network. This network will provide an overarching capability that will provide assured, actionable information from both single-INT and fused all-source data by creating a fully integrated ISR system of systems for end-to-end tasking, collection, processing, exploitation, and dissemination (TCPED) within a global information network.<sup>20</sup>

The ISR-ICSP identifies ISR architecture needs of the future which include dynamic control of theater sensors and platforms; real-time visualization of ISR battlespace information;

---

<sup>19</sup> Ibid. p. 5.

<sup>20</sup> Ibid. p. 5.

decision aids supporting ISR information; and collaborative command and control features.<sup>21</sup> These needs are spelled out in the DoD ISR Vision 21 which is expressed in Figure 1. The vision was developed from top-level guidance spelled out in the *National Security Strategy (NSS)*, the *National Military Strategy (NMS)*, the Director of Central Intelligence’s *Strategic Intent, Joint Vision 2020*, and related Service visions.<sup>22</sup>

The plan articulated in the ISR-ICSP develops a vision and an operational concept for ISR based upon strategic guidance and future mission needs. It identifies current ISR capabilities and new opportunities to meet the needs. Based on this assessment, it develops goals, objectives, and strategic actions necessary to attain the vision. Finally, the plan defines a roadmap intended to guide long-range plans and programs of the services and other agencies to migrate the ISR community toward an “Integrated ISR Enterprise.”<sup>23</sup>

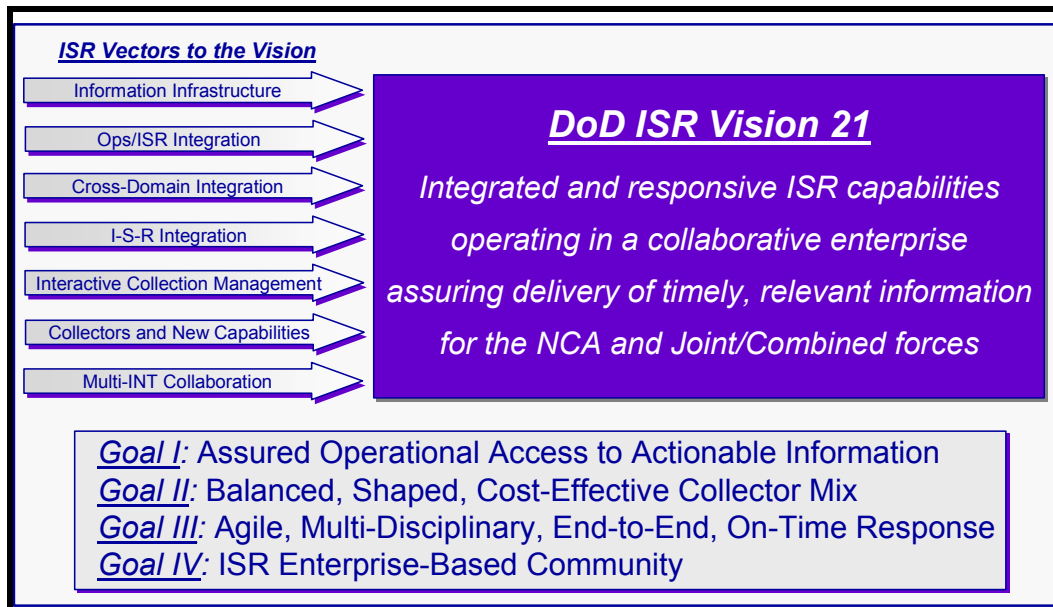

**Figure 1. DoD ISR Vision 21<sup>24</sup>**

In Figure 1, the “ISR Vectors to the Vision” represent common themes along which future ISR operational concepts need to be aligned to reach DoD’s ISR Vision 21. These

<sup>21</sup> Ibid. p. 5.

<sup>22</sup> Ibid. p. vii.

<sup>23</sup> Ibid. p. 1.

<sup>24</sup> Ibid. p. vii.

“vectors” are intended to align the efforts of the ISR community to provide a cost-effective migration path to the 21<sup>st</sup> century. The vectors are explained as follows: <sup>25</sup>

- *Information Infrastructure* is the engine that will enable all ISR Vectors to the Vision. To support the Vision, the ISR community must integrate with other functional communities on the Global Information Grid (GIG), a DoD/Intelligence Community initiative.
- *Ops/ISR Integration* enhances ISR support by integrating it into operational community processes—from the development of military strategy through acquisition, operations planning, and ultimately to execution and combat assessment.
- *Cross-Domain Integration* unites ISR requirements management, collection tasking, processing and exploitation, and product delivery to provide a capability that outperforms what spaceborne, airborne, maritime, and terrestrial systems can do separately.
- *I-S-R Integration* brings all available ISR information and application methods together in a synergistic fashion that clarifies target status and movement and enemy intent in a common operational picture (COP).
- *Interactive Collection Management* provides predictive, dynamic and responsive ISR across all intelligence disciplines through battlespace and asset visualization, integration with real-time operations, and sharing of Ops/Intel information.
- *Collectors and New Capabilities* respond to collection challenges with sound investment strategies and migration plans to achieve a balanced, integrated, cost-effective force mix of spaceborne, airborne, maritime, and terrestrial sensors and platforms.
- *Multi-INT Collaboration* provides near real-time, collaborative TPED in national, theater and tactical facilities, regardless of whether a few feet or multiple time zones separate them.

The future ISR environment spelled out in the ISR-ICSP envisions an open but secure system in which DoD and other Government intelligence networks will be embedded in a global grid that supports Defense and commercial interests concurrently. The focus in the future will shift from collection systems per se to information support, interoperability, connectivity, modernization, and functionality. ISR analysts will interact with unconventional roles like

---

<sup>25</sup> Ibid. p. viii.

information consumers, producers, brokers and data providers. The warfighters' needs for more capable computer hardware will subside as more actionable information is available through increasingly accessible networks.<sup>26</sup>

The operational concept presented in the ISR-ICSP is represented graphically in Figure 2. The vision is for an agile, lightweight, rapidly deployable, and easily reconfigurable theater ISR network which fully supports the theater commander. Worldwide points of entry to the global ISR network will be available for any theater location, thus integrating strategic and tactical ISR. The theater network will provide global network services to the tactical theater, maximize the use of commercial systems, and provide Joint and Combined forces with a common view of the battlespace.<sup>27</sup> This ISR network will function within a larger wide area network distributing all forms of information and data.

---

<sup>26</sup> Ibid. p. 14.

<sup>27</sup> Ibid. p. 17.

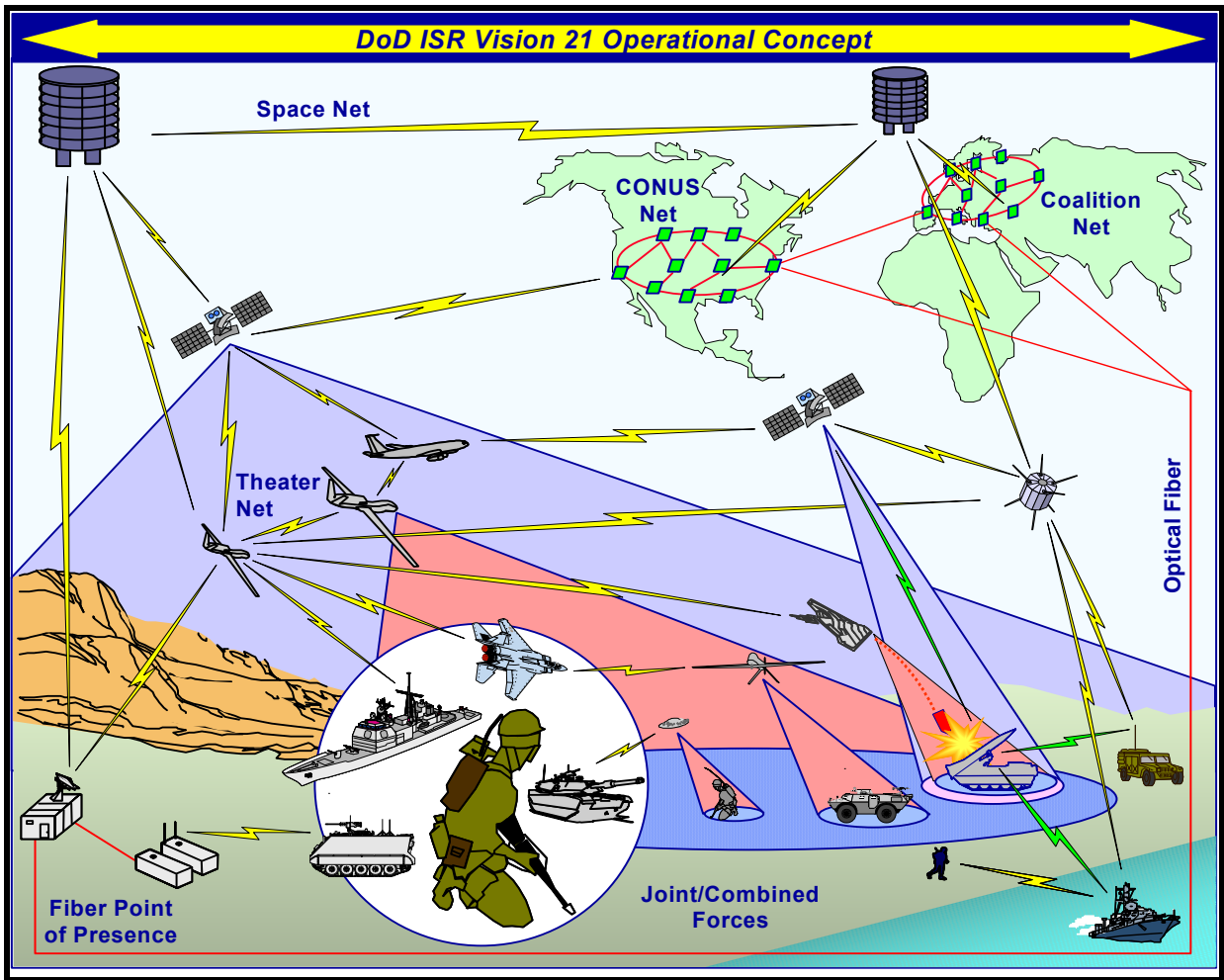

Figure 2. DoD ISR Vision 21 Operational Concept<sup>28</sup>

In this operational concept, both theater and National ISR assets as well as C<sup>2</sup> nodes, are linked together with shooters via surface, air, and space communications centers, exchanging information over a variety of networks. Sensor data, including tactical and theater collection, flows either directly to the warfighter or through high-capacity networks to centers of excellence for processing, exploitation, and near real-time dissemination. Each center of excellence has access to information warehouses and has the ability to correlate information with products from other centers of excellence. This new infrastructure integrates ISR with Joint and Combined operations through tailored information products, distributed operational displays, and near real-time weapons support.<sup>29</sup>

<sup>28</sup> Ibid. p. 19.

<sup>29</sup> Ibid. p. 18.

Collectors are employed in a collaborative way where tasking is neither predetermined by platform nor by INT. The collection management system determines the best collectors or providers among competing resources to collect the needed data. In this manner, the ISR architecture will provide assured access, coverage of the area of interest, timeliness, and robustness. Integration of the collectors will provide a built-in agility and flexibility that responds to the dynamic environment. The collection management system and associated links to the user will allow for near-continuous dialogue between collectors, information suppliers and users. Integration of ISR with operations will shift ISR from a support activity to a critical enabling factor in military operations where the theater commander is confident that assured delivery of timely information is the norm.<sup>30</sup>

## **B. DOD DCGS CRD**

The Department of Defense's overarching requirements statement of a need to integrate the service's ISR systems comes from the DoD Capstone Requirements Document (CRD) for Distributed Common Ground/Surface Systems (DCGS). This CRD captures the overarching requirements for a collection of systems that will contribute to joint and combined warfighter needs for ISR support.<sup>31</sup>

Desert Shield and Desert Storm highlighted a serious deficiency in the services ability to share information. The DoD DCGS CRD was a direct result of these lessons learned. The DoD DCGS program responds to direction within the *FY 97-03 Defense Planning Guidance* which requires a program to mitigate a multi-intelligence (multi-INT), common, interoperable, open systems ground system architecture.<sup>32</sup>

The DoD DCGS CRD is a relatively new document (it was released in January 2003) and as such each service is working hard to develop a road ahead utilizing existing programs which meet the requirements spelled out in this document.

---

<sup>30</sup> Ibid. p. 18.

<sup>31</sup> Joint Requirements Oversight Council. *Capstone Requirements Document for Distributed Common Ground/Surface Systems (DCGS)*. JROCM 001-03. 6 January 2003. p. 1.

<sup>32</sup> Ibid.

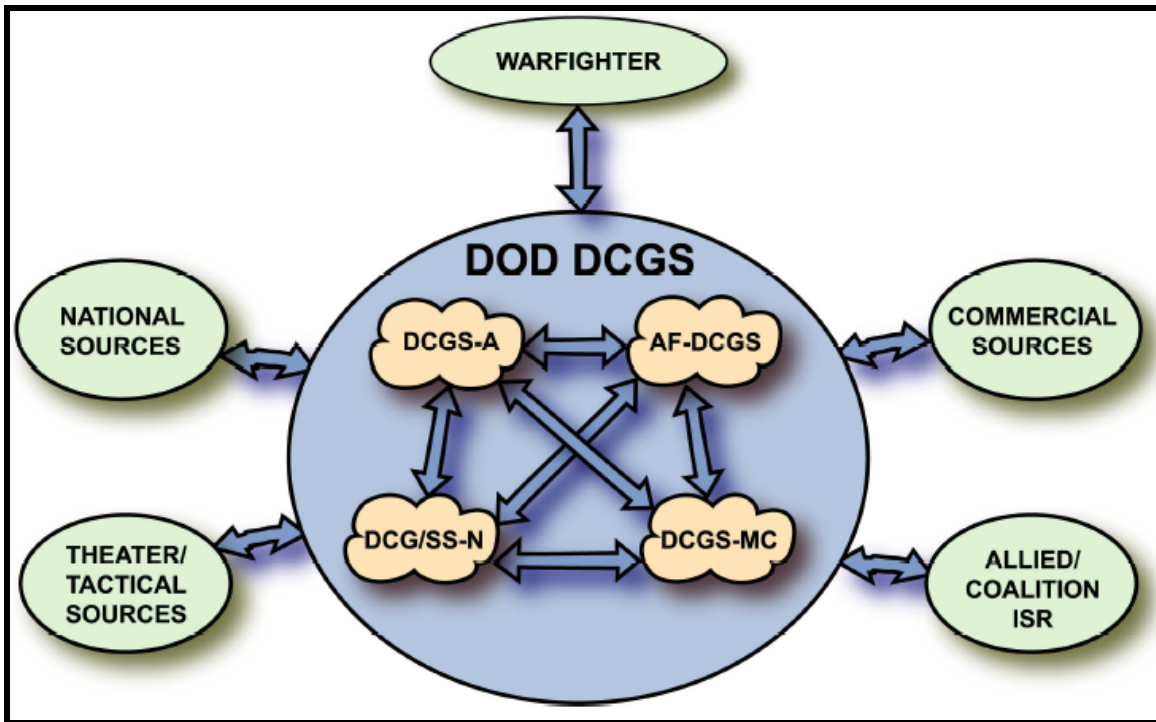

**Figure 3. DoD DCGS Concept<sup>33</sup>**

The term “DoD DCGS” represents a collection of families of systems (FoS), developed by each service within the DoD DCGS CRD guidance, which are connected through designated points of interoperability (Figure 3). These points of interoperability will allow a service’s DCGS system to share information outside of its own network without each individual component needing to be interoperable with each of the other services. To support improved use of bandwidth, DoD DCGS as envisioned, will utilize smart push/smart pull concepts to reduce the amount of unnecessary data sent over the network.<sup>34</sup>

The DoD DCGS CRD states that each service’s FoS will be interoperable, either directly or indirectly, with a core set of platforms and sensors (defined as the baseline). These platforms and sensors are those most likely to be utilized in support of a Joint Force Commander (JFC) and are listed in Table 3.<sup>35</sup>

<sup>33</sup> Ibid. p. 4.

<sup>34</sup> Ibid. p. 6.

<sup>35</sup> Ibid. p. 7.



---

U-2 Dragon Lady	F/A-18 Super Hornet
RQ-4A Global Hawk	RQ-1A Predator
Navy UAV	Tactical UAV (TUAV)
RC-135 RIVET JOINT	RC-12 Guardrail
EP-3	Airborne Reconnaissance Low (ARL)
E-8C Joint Surveillance Target Attack Radar System (JSTARS)	
National Systems	

---

**Table 3. DCGS Baseline Systems**

The core set of platforms will surely require modification in the near future. With the continual improvement of existing systems and development of new systems, the core systems utilized by a Joint Force Commander will change and the DoD DCGS must be capable of changing with it. Therefore, Table 3 merely provides a snapshot of the requirements today and a starting point for identifying the requirements for the future of JFN and other systems which hope to meet the requirements of being a DCGS system.

The DCGS CRD also requires each Service to utilize (to the maximum extent possible) Defense Information Infrastructure – Common Operating Environment (DII-COE) registered Commercial Off-The-Shelf (COTS)/Government Off-The-Shelf (GOTS) segments and COTS/GOTS and Non-Developmental Item (NDI) computer hardware. Use of non-standard components, data formats, and architectures is prohibited without approved and fully coordinated interface documents.<sup>36</sup>

When the requirements identified in the DoD DCGS CRD are met, the theater operational and tactical ISR operational architectures will provide an unprecedented level of flexibility for the JFC. This flexibility will allow the JFC to streamline ISR collection nodes to speed the delivery of information, reduce the time to exploit data, and subsequently will increase the tempo of battle.<sup>37</sup>

---

<sup>36</sup> Ibid. p. 8.

<sup>37</sup> Ibid. p. 3.

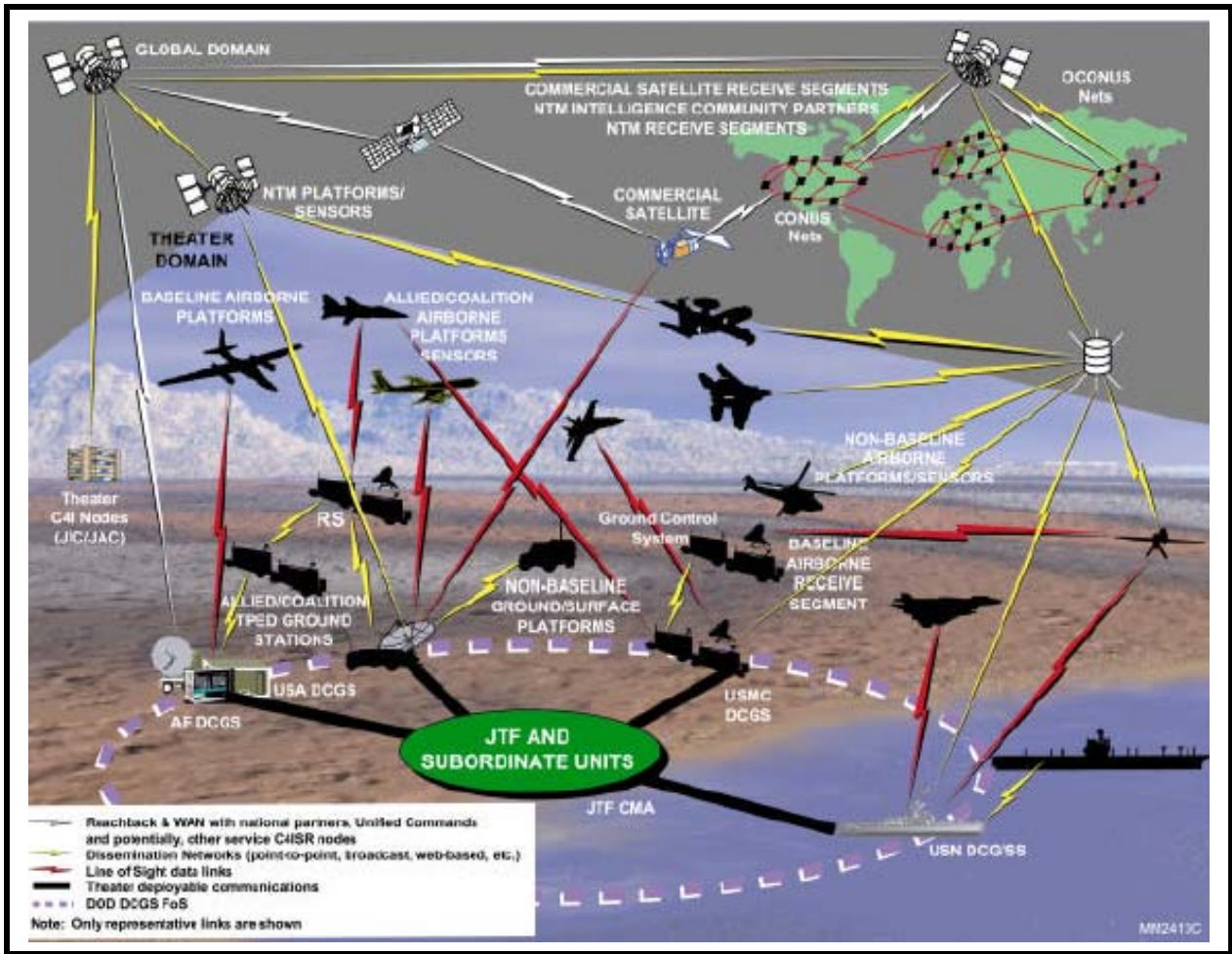

**Figure 4. DoD DCGS High-level Operational Concept (OV-1)<sup>38</sup>**

The operational concept presented in the DoD DCGS CRD is similar to the operational concept presented in the ISR-ICSP. Figure 4 represents a high-level overview of this concept. From garrison, on through scalable, modular system deployments, DoD DCGS will support multiple, simultaneous, worldwide operations. DoD DCGS will be interoperable with spaceborne, airborne, and surface ISR collection assets and intelligence producers and able to access intelligence databases from these ISR resources. The DoD DCGS will support Joint Task Force (JTF)-level campaign planning, targeting, combat assessment, and combat execution. The DoD DCGS will support the JFC and below, ISR requirements for battle management and information dominance across the spectrum of conflict. Service DCGS elements must be equipped for, and capable of, worldwide operations and may be tasked to support any specific

<sup>38</sup> Ibid. P. 6.

JFC or below to achieve operational objectives.<sup>39</sup> Service DCGS FoSs must be network-centric, and of a modular, scalable design to enable planners to tailor forward deployments and rear-echelon elements to satisfy Joint and Combined Force ISR requirements efficiently.<sup>40</sup>

### **C. DRAFT DOD DCGS JOINT OPERATIONAL CONCEPT**

In July 2002, the Joint Requirements Oversight Council (JROC) tasked United States Joint Forces Command (USJFCOM) to review the service's ability to support joint warfighter intelligence requirements in a distributed network by using service-procured DCGS elements. In December that same year, USJFCOM reported the following findings:<sup>41</sup>

- JTF Commanders cannot effectively capitalize on service DCGS investments. Services have funded their system interfaces without fully addressing Joint Doctrine, a Joint Operational Concept, or Joint Tactics, Techniques, and Procedures (JTTP).
- Service-unique ground processing and exploitation systems supporting JTFs operate in a service-centric manner, are single-discipline focused, and do not share or collaborate on intelligence information in near-real time.
- JTFs require net-centric joint ISR operations facilitating distributed/federated exploitation through collaboration and information sharing – multi-discipline/ multi-INT / multi-ISR fusion.

The JROC subsequently issued a July 2002 memorandum (JROCM 124-02) and a December 2002 memorandum (JROCM 208-02) endorsing USJFCOM's strategy for fixing the shortfalls through a DCGS Joint Operational Concept. The strategy spelled out in this document covered the following areas:<sup>42</sup>

- Develop a Joint Operational Concept (“As Is”), circa 2003, with joint doctrinal and JTTP identification/recommendations
- Develop a Joint Operational Concept (“To Be”), circa 2015

---

<sup>39</sup> Ibid. p. 5.

<sup>40</sup> Ibid. p. 7.

<sup>41</sup> United States Joint Forces Command. Draft DoD Distributed Common Ground/Surface Systems Joint Operational Concept. Revision 0.9. 7 April 2003. p. 6

<sup>42</sup> Ibid. p. 6-7.

- Capitalize on the Office of the Assistant Secretary of Defense (ASD) Command, Control, Communications, and Intelligence (C3I) ISR Programs Directorate ISR Architecture Development
- Capitalize on Joint Intelligence, Surveillance, and Reconnaissance (JISR) Joint Experimentation efforts
- Feed ISR Joint Warfighter Capabilities Assessment (JWCA) overarching ISR Joint Operational Capability/Joint Operational Architecture (JOC/JOA) development efforts
- Develop joint training materials and applicable collaboration training materials for JTF-level representatives
- Develop leadership education materials to facilitate senior decision-maker awareness of flexibility and options for networked, multi-Service, DCGS employment

The Draft DoD DCGS Joint Operational Concept also supports the architecture development objective of ASD (C3I) ISR Programs Directorate which recognized a need to develop DCGS architectures which link the principles expressed in the ISR Integrated Capstone Strategic Plan (ISR-ICSP), the DCGS CRD, and the ASD(C3I) vision of “Power to the edge.”<sup>43</sup>

The draft concept outlines the strategy for interoperability and integration between and among the service DCGS programs, systems, and capabilities to achieve the goals of the DCGS vision and to address the shortfalls originally identified by USJFCOM (listed previously). Specific goals of DCGS, as identified within this document, include:<sup>44</sup>

- Providing joint warfighters the flexibility for force tailoring of multiple-service platforms/sensors, with processing/exploitation systems to meet the challenges of a dynamic operational environment
- Establishing a multi-service, multi-INT, multi-ISR network for time sensitive targeting capability enabled by a shared information environment
- Developing common exploitation, information management, network security, and network management tools/capabilities

---

<sup>43</sup> Ibid. p. 7.

<sup>44</sup> Ibid. p. 10.

The future of battlespace command and control will require services to shift their focus from service-centric to a Joint Force focus in which a common operating picture provides the commander a comprehensive, accurate, clear, and coherent picture of the battlespace in which “blue” (friendly), “red” (enemy), and “white” (neutral) forces are clearly displayed. Planning tools must be available which can predict information requirements of the decision maker as well as react to requests for information in a manner which truly supports the person’s ability to make decisions. The system must also allow for dynamic re-tasking of sensors to optimize available assets. Multiple sensor cross-cueing will become routine and the synchronization of ISR assets with operations the norm. The DoD DCGS will form the nucleus of much of this activity. Minimum baseline features identified in the Draft DoD DCGS Joint Operational Concept for a joint ISR management system include:<sup>45</sup>

- A simple planning feature where the operator enters sensor parameters to determine basic collection feasibility
- Capability to retask a sensor(s) (when authorized)
- Access to a JTF database (server) for priority intelligence requirements (PIR), strategy, objectives, courses of action, etc.
- Ability to produce a Master Collection List
- Access to finished Intelligence Preparation of the Battlespace (IPB) products
- Access to other databases such as Imagery Exploitation Support System (IESS), Requirements Management System (RMS), Modernized Integrated Data Base (MIDB), National Exploitation System (NES), etc.
- Access to tactics, techniques, and procedures (TTP) summaries, basic platform/sensor performance, and usage guidance for U.S., allied and coalition ISR platforms and sensors
- Access to ISR Synchronization Matrix

---

<sup>45</sup> Ibid. p. 15.

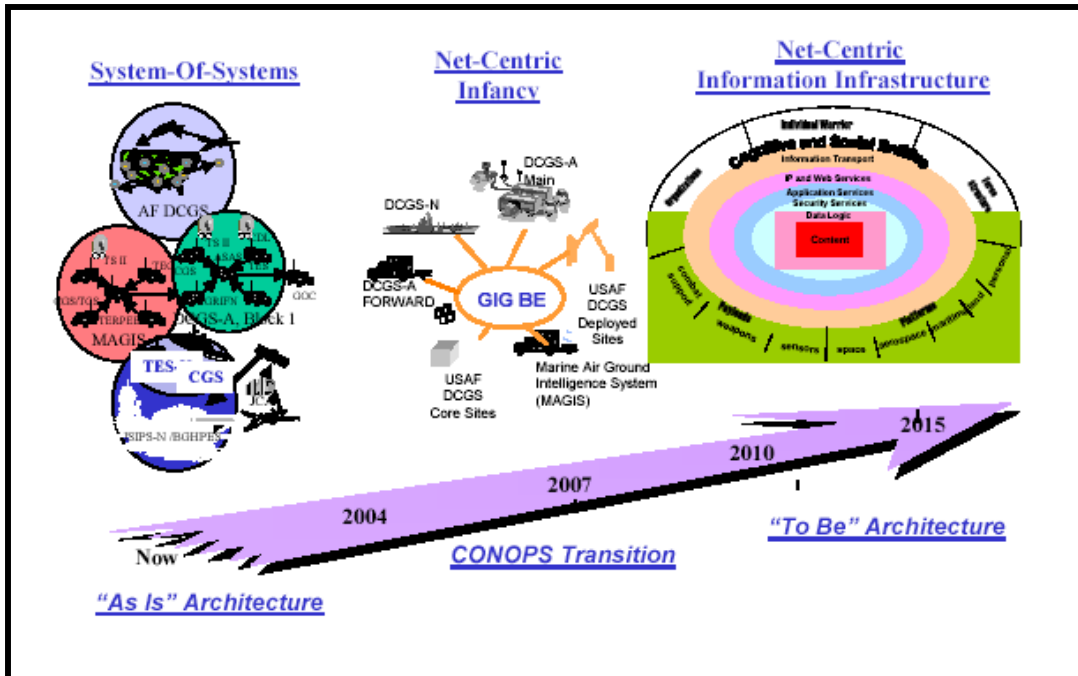

**Figure 5. DCGS Migration Path<sup>46</sup>**

In the past, each service has developed mission-specific elements to support their ISR needs. However, these systems have shortfalls in required interfaces, robust connectivity, doctrine, etc. Figure 5 depicts the migration path toward full implementation which is expressed in the Draft DoD DCGS Joint Operational Concept. In the FY03-09 period, each service is focused within itself to develop systems which meet the basic tenets of the DoD DCGS strategy tailored to meet its own core competencies. Implementation during this period is based on service design requirements and may or may not meet joint operational needs for information exchange in the “To Be” architecture.<sup>47</sup> In order to achieve the demands of the “To Be” view of the future, DCGS will have to focus on the following key thrust areas:<sup>48</sup>

- Integrated into the global network structure
- Reliant on sanctuary processing and exploitation (CONUS or theater)
- Descriptive of “posting before processing”

<sup>46</sup> Ibid. p. 18.

<sup>47</sup> Ibid. p. 18.

<sup>48</sup> Ibid. p. 28.

- Capable of handling all sources of ISR information
- Capable of full integration of “other than ISR” information
- Fully depicts the transport and IP convergence layers

In the emerging intelligence handling environment of task, post, process, and use (TPPU), intelligence information will be posted before being processed. This will facilitate multiple and simultaneous uses of collected data. Users will have immediate access to collected data. This environment will create a collaborative and interactive environment where users can either contribute to the collective knowledge environment or request additional information beyond that which is contained in the information portal, or posted data area.<sup>49</sup>

DoD DCGS will also provide the information source for the Standing Joint Force Headquarters (SJFHQ) once it moves from concept to reality. General Kernan, Commander USJFCOM, in a statement to Congress on 9 April 2002 identified SJFHQ as a “high-value means to reduce the ad-hoc nature of today’s JTF operations and increase timeliness, effectiveness, and efficiency of future operations.” SJFHQ will provide each regional Combatant Commander an informed and in place command and control capability. The goal for the SJFHQ is expressed in Figure 6 and its characteristics include:<sup>50</sup>

- A standing, coherent team of “joint generalists” led by a Flag/General Officer
- Mission tailorable
- Have extensive training and knowledge of joint operations
- Possess an ongoing understanding of the Combatant Commanders’ theater perspective and knowledge of the Area of Responsibility (AOR), key issues, “regional players”
- Have its own C4I equipment

---

<sup>49</sup> Ibid. p. 29.

<sup>50</sup> Ibid. p. 24-25.

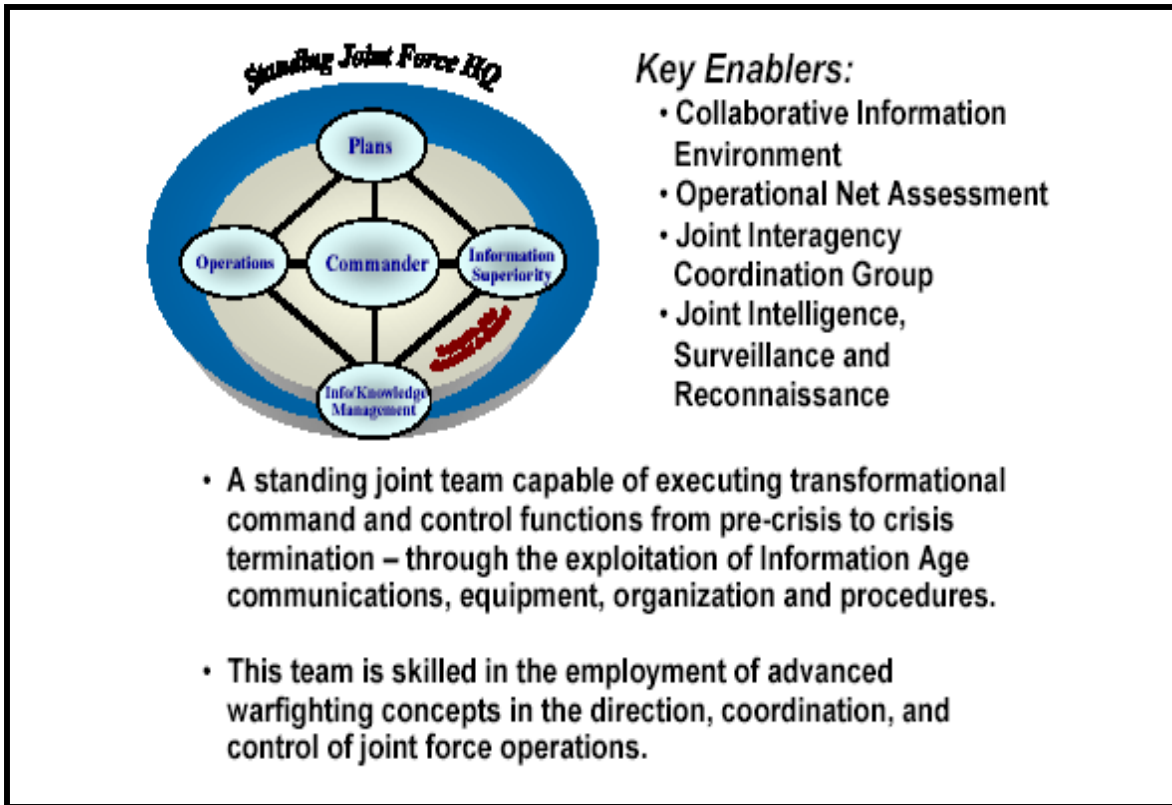

**Figure 6. Standing Joint Force Headquarters – The Goal<sup>51</sup>**

DCGS is evolving to include all collection disciplines – IMINT, SIGINT, MASINT, Human Intelligence (HUMINT), and Open – Source Intelligence (OSINT). This capability will be realized through net-centric operations empowered by an integrated architecture. Proceeding to the future will require robust, dedicated connectivity, layered network security, and most importantly, a change in procedures to allow for open access to all collected data (processed/unprocessed) by all authorized users. Collaborative tools linking geographically separated staffs are crucial to the transformation of DCGS and allow DCGS to operate in a joint, net-centric environment providing rapid, responsive support to decision-makers and commanders.<sup>52</sup>

DCGS currently operates using a reach back capability. However, enhanced robust collaboration tools will allow for breaking away from traditional sequential operations to a

<sup>51</sup> Ibid. p. 25.

<sup>52</sup> Ibid. p. 25.



parallel, simultaneous operations environment. Parallel planning is inherently more flexible and will compress planning and operations timeline.<sup>53</sup>

When networked to a SFJHQ, a DCGS will have real- and near-real time connectivity with both forward deployed and rear area forces. If adequately manned, the DCGS has the potential to act as a mini-Joint Intelligence Center (JIC).<sup>54</sup>

In summary, the *Draft DoD DCGS Joint Operational Concept* identifies the following characteristics for the evolved DCGS:<sup>55</sup>

- Providing Joint Warfighters the flexibility to mix and match service platforms/sensors, with different processing/exploitation systems to meet dynamic operational environments.
- Establishing a multi-service, multi-INT / multi- ISR network for time sensitive Targeting.
- Developing common exploitation, network security, and network management capabilities.
- Receiving and processing data from any sensor or source.
- Receiving and operationally responding to cues from other sources of information.
- Receiving and exploiting multi-INT / multi-ISR information from other DCGS elements or other sources.
- Supporting the distributed exploitation concept, which is the capability to schedule and allocate raw, unprocessed multi-INT information dissemination and exploitation tasks among elements and/or exploitation centers distributed worldwide.
- Providing products that are directly useable by other DCGS elements and the joint warfighter in general.
- Implementing commercial, open systems standards.
- Supporting connectivity with other DCGS elements and C4I resources.

---

<sup>53</sup> Ibid. p. 26.

<sup>54</sup> Ibid. p. 26.

<sup>55</sup> Ibid. p. 35.

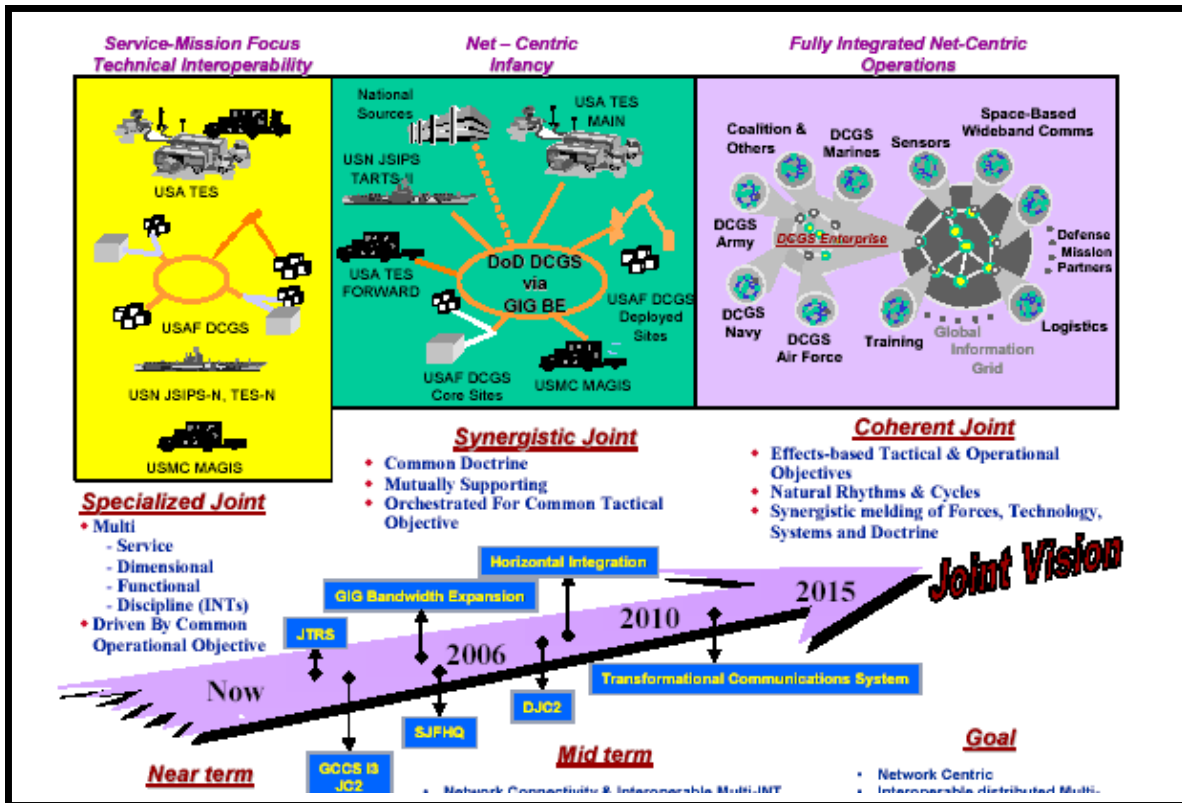

Figure 7. DCGS Integrated Strategy to Achieve the Vision

The progression of the DoD DCGS concept will evolve over three phases as depicted in Figure 7 above. First, each service is working to develop its own plan for sharing ISR information within itself. The second phase involves sharing information across DoD and the final phase involves sharing DoD's ISR information across the GIG.

#### D. CHAPTER SUMMARY

DoD has developed DCGS as both a strategy and the desired end state for the ISR architecture of the future. DoD also put in place an oversight council and associated working group level IPTs to lead the way ahead for the services on ISR integration. This body is guiding the implementation of the Office of the Secretary of Defense's vision for a multi-intelligence, multi-platform, TPED architecture for ISR collection systems.

DoD has also identified in its ISR-ICSP how important ISR interoperability will be in the future. This plan identifies ISR architecture needs of the future which include dynamic control

of theater sensors and platforms; real-time visualization of ISR battlespace information; decision aids supporting ISR information; and collaborative command and control features.

The future of ISR, as envisioned in the ISR-ICSP, will see a shift in focus from collection systems per se to information support, interoperability, connectivity, modernization, and functionality. ISR analysts will interact with unconventional roles like information consumers, producers, brokers and data providers. The warfighters' needs for more capable computer hardware will subside as more actionable information is available through increasingly accessible networks.

Collectors will be employed in a collaborative way where tasking is neither predetermined by platform nor by INT. The collection management system will determine the best collectors or providers among competing resources to collect the needed data. To support improved use of bandwidth, DoD DCGS as envisioned, will utilize smart push/smart pull concepts to reduce the amount of unnecessary data sent over the network.

The Capabilities identified in the DoD ISR-ICSP, DoD DCGS CRD and the Draft DoD DCGS Joint Operational Concept are summarized in Table 4. The capabilities listed in this table will be utilized later on to assess whether or not JFN will be capable of operating within a Joint Force ISR architecture and functioning as the Navy's DCGS.

DoD DCGS, once realized, will provide the JFC and all other subordinate commanders with unprecedented levels of quick, accurate information in support of command and control of Joint Forces. JFN Resource Sponsors and Program Managers need to incorporate these requirements early on in the development of this system to ensure its ability to function properly in a DoD DCGS environment. The next chapter will look at each service's view of the ISR architecture on the battlefield of the future.

- 
- Ability to share ISR information with other service's ISR systems
  - Real-time visualization of ISR battlespace information
  - Comprehensive, accurate, clear, and coherent picture of the battlespace which includes "blue" (friendly), "red" (enemy), and "white" (neutral) forces
  - Collaborative command and control features
  - Minimization of unnecessary data sent over the network
  - DII-COE registered COTS/GOTS equipment utilized as much as possible
  - Planning tools which predict information requirements and react to specific requests
  - Enable dynamic retasking of sensors
  - Allow for multiple sensor cross-cueing and synchronization of ISR assets with operations
  - Access to finished Intelligence Preparation of the Battlespace (IPB) products
  - Access to TTP summaries, basic platform/sensor performance, and usage guidance for U.S., allied, and coalition ISR platforms and sensors

---

**Table 4. DCGS Capabilities Summary**

THIS PAGE INTENTIONALLY LEFT BLANK

### **III. THE FUTURE OF ISR SYSTEMS**

In response to guidance provided by DoD over the past couple of years regarding increased networking and interoperability within and between the services, each service is embarking on aggressive plans to develop a grid of information which allows information to be entered once, and available to all. This chapter will first discuss the role of the Joint Interoperability Test Command (JITC) which was put in place to oversee system interoperability across DoD and then look at a systems level view of the ISR capabilities of the future for the Air Force, Army and Marine Corps. The Navy's ISR systems will be discussed in the following chapter along with a description of JFN.

#### **A. JITC**

The Defense Information Systems Agency (DISA) created an organization independent of any particular service which is charged with establishing and testing interoperability standards within DoD. This organization is called the Joint Interoperability Test Command (JITC) and is located at Fort Huachuca in Arizona. The mission of JITC is to act as DoD's independent operational test and evaluation assessor of DISA and other DoD C4I acquisitions. They also identify C4I and combat support system interoperability deficiencies and provide joint and combined C4I interoperability testing, evaluation and certification.<sup>56</sup>

Although DISA established this organization to test interoperability of C4I systems within DoD, getting legacy systems tested has proven extremely difficult. In March 2003, the General Accounting Office (GAO) released a report on the steps which DoD needs to take in order to ensure interoperability of its systems. This report states that of 26 DCGS systems looked at by GAO, only two had been certified by JITC. Of the remaining 24 systems, 3 were in the process of being certified; 14 had plans for certification; and 7 had no plans for certification. To help enforce the certification process, in December 2000 DoD asked four key officials (the Under Secretary of Defense for Acquisition, Technology & Logistics; the Assistant Under Secretary of Defense for Command, Control, Communications, and Intelligence; the Director of Operational Test and Evaluation; and the Director, Joint Staff) to periodically review systems

---

<sup>56</sup> Joint Interoperability Test Command website. [jitic.fhu.disa.mil]. May 2003.

and place those with interoperability deficiencies on a “watch list.” This designation would trigger a series of progress reviews and updates by the program manager, the responsible testing organization, and JITC, until the system is taken off the list.<sup>57</sup>

Information regarding specific system certifications as mentioned in the GAO report, will be addressed in the following sections which discuss each service’s ISR systems.

## **B. AIR FORCE ISR**

The United States Air Force (USAF) is embarking on a block upgrade to its Air Force Distributed Common Ground System (AF DCGS) to improve current capability and achieve a multi-INT, distributed exploitation capability. This block update is referred to as Block 10.2 Multi-INT Core and will replace existing AF DCGS, MASINT, IMINT, and all source analysis capabilities.<sup>58</sup>

The AF DCGS is a worldwide distributed, network centric, system-of-systems architecture which supports collaborative intelligence operations and development of intelligence products. The environment provides for both the physical and electronic distribution of ISR data, processes, and systems. As an integrated component of the DoD information grid, this system serves as the Air Force’s primary tasking, processing, exploitation and dissemination (TPED) architecture for delivery of direct and indirect ISR information to the Joint Force Air Component Commander (JFACC). The JFACC uses this system for ISR management, intelligence preparation of the battlespace (IPB), predictive battlespace awareness, indications & warning, current intelligence, assessment of military force and support capabilities, analysis of enemy courses of action (intent), targeting & weaponeering, mission planning, and air combat training missions execution.<sup>59</sup>

The Block 10.2 Multi-INT Core system is the initial step toward a future DCGS that will transition the Air Force’s system to greatly improved performance, interoperability, and

---

<sup>57</sup> General Accounting Office. Report to the Chairman, Committee on Armed Services, House of Representatives: *Defense Acquisitions- Steps Needed to Ensure Interoperability of Systems That Process Intelligence Data*. GAO-03-329. March 2003. p. 10.

<sup>58</sup> Statement of Objectives for the Air Force Distributed Common Ground System Block 10.2 Multi-INT Core Upgrade. SOO No. AFDCGS-03-002. 01 May 2003. p. 2.

<sup>59</sup> Air Force Distributed Common Ground System (AF DCGS) Block 10.2 Air Force Multi-INT Technical Requirements Document. No. AFDCGS-03-002. 01 May 2003. p. 7.

integration with the Air Operation Center (AOC) weapon system. The objective is described in the AF DCGS Strategic Plan as follows:<sup>60</sup>

A globally integrated, distributed, and collaborative information technology enterprise; capable of continuous on demand intelligence brokering to achieve full spectrum dominance by enabling America and allied aerospace forces to change the course of events in hours, minutes or even seconds.

On 21 April 2003, the Air Force issued a Request For Proposal (RFP) to build the Block 10.2 Multi-INT Core. The RFP included requirements for the Air Force's system (Block 10.2) as well as a DCGS Integration Backbone (Backbone) which will provide the minimal functionality necessary to interface information systems between services to construct a multi-INT core which allows for information exchange over the AF DCGS Enterprise as well as other DoD DCGS components.<sup>61</sup>

Prior to release of the Block 10.2 solicitation, the Air Force provided the opportunity for the other services to join in on this procurement and to have their individual requirements included. The Air Force described what Block 10.2 Multi-INT Core was going to do for them and from that the services developed the Backbone which consists of the requirements common to all services. Separate from that, the services were provided the opportunity to include individual Technical Requirements Documents (TRD) to cover their specific needs. The Navy was the only service to take advantage of this opportunity and included their own TRD. The Navy's TRD will be discussed in the following chapter.<sup>62</sup>

The Multi-INT Core, using the foundation provided by the Backbone, will provide an integrated information management process employing the metadata tags to associate all data within the system. The integrated information management process will employ a platform and application independent user interface. Collaboration will exist at the information object level, involving the dynamic access and manipulation of information at geographically separate areas.<sup>63</sup>

---

<sup>60</sup> Ibid. p. 7.

<sup>61</sup> Ibid. p. 7.

<sup>62</sup> E-mail from MAJ Harry Sears, USAF. Chief of Naval Operations Staff (N20). 21 May 2003.

<sup>63</sup> Air Force Distributed Common Ground System (AF DCGS) Block 10.2 Air Force Multi-INT Technical Requirements Document. p. 7.



The ability of the AF DCGS to distribute missions and perform collaboration is highly dependent upon a robust communications infrastructure. The DCGS processing, exploitation, and dissemination system (PEDS) Architecture (DPA) is considered one of the primary capabilities of the AF DCGS. It encompasses the entire architecture (to include the DPA) of connectivity supporting the PEDS. Its interfaces and capabilities are interdependent upon any change or upgrade of any sensor to shooter capability. <sup>64</sup>

The Block 10.2 Multi-INT Core proposal TRD requires interoperability with the sensors listed in Table 5, as well as the TPED systems in Table 6, and the command and control systems listed in Table 7.

- 
- |                     |                    |
|---------------------|--------------------|
| • U-2               | • TARS             |
| • National ELINT    | • National IMINT   |
| • Global Hawk IMINT | • Commercial IMINT |
| • Predator          | • JSTARS           |
- 

**Table 5. Block 10.2 Multi-INT Core Required Collectors<sup>65</sup>**

- 
- |            |  |
|------------|--|
| • CROFA:   | RF-INT   |
| • DCGS-N:  | Imagery, Sensor Planning Data, Sensor Control Data, Motion Imagery, Multi-INT Data, MTI Data, RF-INT |
| • DCGS-MC: | Imagery, Sensor Planning Data, Sensor Control Data, Motion Imagery, Multi-INT Data                   |
| • DCGS-A:  | Imagery, Sensor Planning Data, Sensor Control Data, Motion Imagery, Multi-INT Data, MTI Data, RF-INT |
- 

**Table 6. Block 10.2 Multi-INT Core TPED Interoperability Requirements<sup>66</sup>**

---

<sup>64</sup> Ibid. p. 7.

<sup>65</sup> Ibid. p. 33.

<sup>66</sup> Ibid. p. 9.

- 
- Joint Services Workstation: MTI Data, Imagery, Sensor Planning Data, Motion Imagery, Multi-INT Data
  - AF Mission Support: Collection Platform Navigation Tracks, Collection Plan
  - Air Operations: Imagery, Sensor Planning Data, Motion Imagery, Multi-INT Data
  - Time Critical Targeting: Imagery, Sensor Planning Data, Motion Imagery, Multi-INT Data
  - All Source Analysis: Formatted Intelligence Reports
- 

**Table 7. DCGS Backbone C2 System Interoperability Requirements<sup>67</sup>**

### **1. DCGS Integration Backbone**

The DCGS Integration Backbone (Backbone) (Figure 8) will provide the tools, standards, architecture, and documentation for the DCGS community to achieve a multi-INT (e.g. IMINT, SIGINT, MASINT, CI/HUMINT), network centric environment with the interoperability to afford individual nodes access to the information needed to execute their respective missions. This will enable a higher level of fusion to enhance all-source analysis. When realized, the requirements in the DCGS Backbone TRD will enable an unprecedented level of operational flexibility and Joint interoperability. The Backbone provides a commercial-off-the-shelf (COTS) enterprise integration framework with the capability to integrate the components and networks necessary to form a distributed and collaborative enterprise over network communications.<sup>68</sup>

---

<sup>67</sup> Ibid. p. 10.

<sup>68</sup> DCGS Integration Backbone Technical Requirements Document. DIB TRD No. DCGS-03-002. 01 May 2003. p. 3.

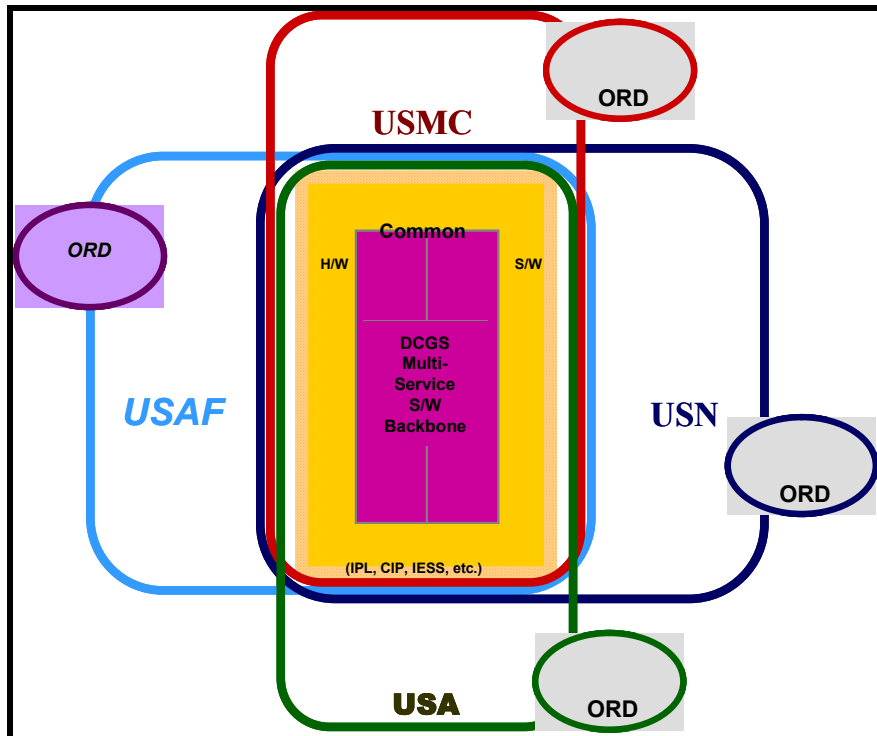

**Figure 8. DCGS Integration Backbone<sup>69</sup>**

The Backbone is both a software architectural framework and a developer’s toolkit. It provides the minimal functionality necessary to interface information services to TPED/TPPU systems and exchange information between them. This is accomplished by providing the ground-rules for accessing system resources to include the required open and government standards, interface mechanisms, and information definitions. The ability to get at and move information is also part of this framework. It provides the system with knowledge of what information is available, where the information is located, and where it needs to go. It understands what processing services are available on the network. Lastly, it provides enterprise-wide system services for security, web access, and other basic features. The Backbone is fully open and documented to ensure that any vendor can develop and integrate services to the backbone.<sup>70</sup>

The Backbone will facilitate constructing TPED/TPPU systems in a tiered integrated information management structure similar to the Air Force’s Block 10.2 Multi-INT Core which

<sup>69</sup> DCGS Integration Backbone Summary Briefing. USAF Material Command.

<sup>70</sup> DCGS Integration Backbone Technical Requirements Document. p. 3.

includes a Repository Layer, a Service Layer, and a Viewer Layer (Figure 9). The Repository Layer contains all information storage; the Services Layer contains conversion, fusion, and manipulation engines; the Viewer Layer contains all elements of user interface and presentation. An object oriented transport infrastructure connects each layer. Ground rules will allow TPED/TPPU systems to affix metadata tags to data with time stamps, reference to information sources, information processing pedigree, geographic reference, and target reference.<sup>71</sup>

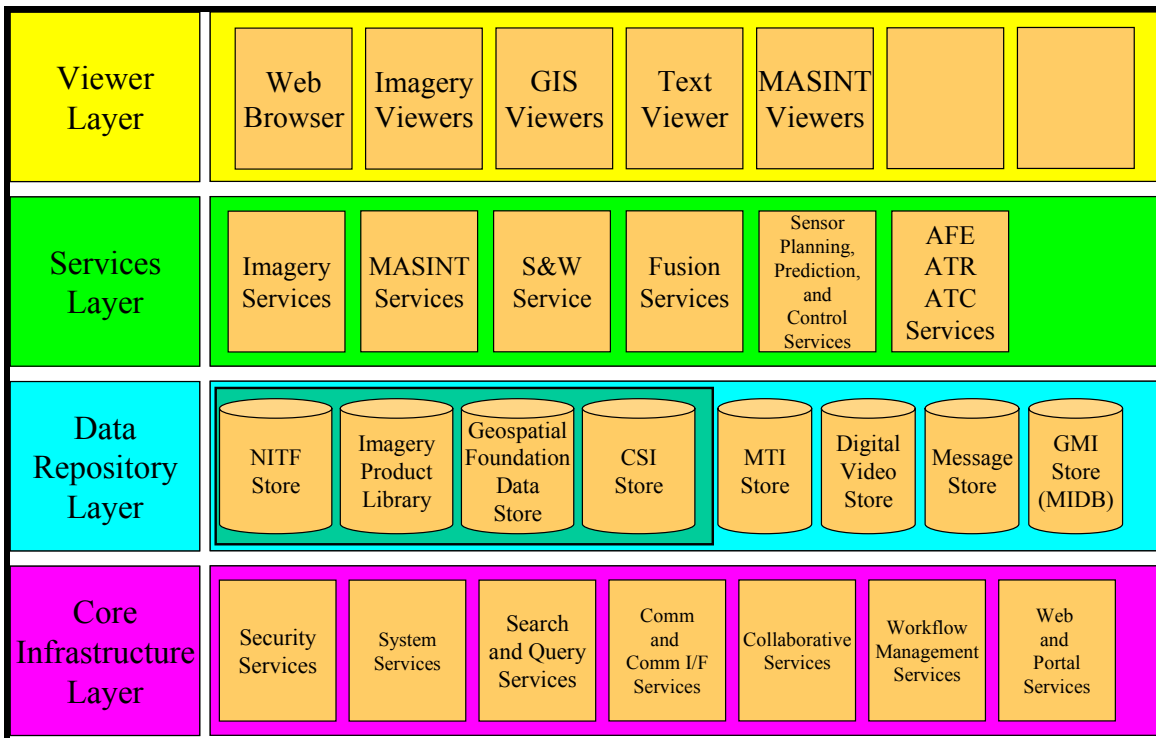

**Figure 9. DCGS Integrated Backbone Layers<sup>72</sup>**

The Backbone will also facilitate scalability and backwards compatibility to legacy applications. The combination of established standards, documentation, and multi-service ground rules provides transparent application interfaces for further flexible development. A range of integration levels provide TPED/TPPU system providers with the tools to ensure backwards compatibility of critical applications.<sup>73</sup>

<sup>71</sup> Ibid. p. 3.

<sup>72</sup> DCGS Integration Backbone Summary Briefing.

<sup>73</sup> DCGS Integration Backbone Technical Requirements Document. p. 3.

The Backbone will facilitate an integrated information management process which employs metadata tags to associate all data. The integrated information management process will employ a platform and application independent user interface. The Backbone will also facilitate collaboration at the information object level, involving the dynamic access and manipulation of information at geographically separate areas. This collaboration will include a combination of human and machine interfaces.<sup>74</sup>

## **2. Backbone Interoperability**

The Backbone and the information services implemented in the DoD DCGS Enterprise will improve the interoperability that is the key to the collaborative and distributed nature of the vision articulated in the DCGS Capstone Requirements Document (CRD). Open and documented standards (commercial and government) are critical to this effort. Interoperability enabled by the Backbone reflects the DCGS CRD mandate to include:<sup>75</sup>

- Interoperability between baseline ISR sensors/collectors and DoD DCGS components
- Interoperability between ISR, C2, and DoD DCGS components
- Interoperability between TPED/TPPU and analysis capabilities across the DCGS enterprise
- Interoperability between DoD DCGS components and warfighters
- Open system design and documentation to ease interoperability burdens in the future

The DCGS CRD requires that individual service DCGS architectures be interoperable at requisite classification levels to provide joint and combined warfighters with the required capabilities. As advanced technology enables the combination of multiple sources of data into single systems, the problem of handling multiple data formats is magnified. The intent of the

---

<sup>74</sup> Ibid. p. 3.

<sup>75</sup> Ibid. p. 4.

Backbone is to eliminate the proliferation of proprietary solutions and interfaces for TPED/TPPU systems. The Backbone will provide the tools, standards, architecture, and documentation for the DoD DCGS community to achieve a multi-INT, network centric environment with the interoperability to afford individual DCGS nodes access to the information needed to execute their respective missions. This will enable fusion and enhance all-source analysis.<sup>76</sup>

As envisioned in the DCGS CRD, the Backbone will enable the following:<sup>77</sup>

- Improve the accuracy and timeliness of intelligence provided to the warfighter
- Promote ownership efficiencies, common investment opportunities, and a balanced, cost-effective TPED/TPPU force mix
- Promote a standards-based ISR infrastructure to increase inter-Service and agency TPED/TPPU collaboration and ISR platform management.
- Mitigate integration risks associated with future ISR technologies and enhancements.
- Improve data accessibility as defined by the TPPU vision.

The Backbone will provide the tools, architecture, standards, and documentation to support interface with IMINT and MASINT sources at the minimum, but an objective is to include SIGINT and CI/HUMINT sources as well.<sup>78</sup>

### **3. GAO DCGS Findings**

The GAO report reviewed the status of the Deployable Shelterized System, the Deployable Transit-Cased System, the Korean Combined Operations Intelligence Center; Ground Control Processor; Deployable Ground Intercept Facility; and the Tactical Exploitation System (TES) Intelligence Reconnaissance Manager. All of these systems have testing planned

---

<sup>76</sup> Ibid. p. 4.

<sup>77</sup> Ibid. p. 4.

<sup>78</sup> Ibid. p. 4.

with the exception of the Korean Combined Operations Intelligence Center which is in the process of testing.<sup>79</sup> These systems together comprise AF DCGS.

### **C. ARMY ISR**

The Army is in the midst of changing its fighting forces from a large heavily armored force, to a much smaller and more maneuverable lighter force. The Army views its Objective Force of the future as comprised of Units of Action and Units of Employment. The Units of Action are its lower level units which encompasses its tactical warfighting units (Brigade and below). The Units of Employment are the higher level units which provide overarching command and control of forces (Division, Corps, and Echelon Above Corps).

The Army's lighter and more agile forces will provide massed effects through networked, simultaneous operations. Instead of large armies attacking force on force, units will be employed to strike enemy centers of gravity and require smaller logistics footprints. Enhanced situational awareness will be provided via a global C4ISR network.<sup>80</sup>

---

<sup>79</sup> GAO Report. p. 10-11.

<sup>80</sup> Masback, Mr. Keith. Director, ISR Integration, U.S. Army Headquarters. Briefing to the Armed Forces Journal ISR Symposium. 21 November 2002.



**Figure 10. Objective Force Operational Concept<sup>81</sup>**

As depicted in Figure 10, the Army's Operational Concept is based on the following principles:<sup>82</sup>

- Net centric, knowledge based
- Manned & unmanned ground-air system
- Integrated, fused multi-INT and non-multi-INT sensors
- Multi-skilled, adaptive soldiers & civilians
- Assured access to and interdependent with Joint and National Intelligence systems
- Robust reach and project
- Visualization at the point of decision

The Army expects heavy reliance on theater and national ISR information during entry operations into an area but, during decisive operations the reliance shifts to organic ISR assets.

<sup>81</sup> Ibid.

<sup>82</sup> Ibid.



After the decisive operations are completed and the force transitions, the reliance on non-organic ISR assets will increase again.<sup>83</sup>

The Army's view of the future requires a multi-INT sensor capability, correlation/fusion of multiple sensor data inputs to produce a single output, vertically & horizontally integrated architecture, real-time sensor-to-shooter decision processes, and timely red and blue picture which supports small unit engagements.<sup>84</sup>

The Army's DCGS (DCGS-A) Block 1 program is based upon four spirals which will occur through FY 08. Spiral 1 which is occurring this year involves using COTS/GOTS workstations and proven current force software applications to integrate HUMINT, MASINT, IMINT, and SIGINT into a single picture. Spiral 2 (FY 04) involves reducing the forward footprint of the system and improving interoperability and information sharing among forward TES units. Spiral 3 (FY 05) involves reducing the footprint of the system and improving interoperability and information sharing among TES main units. Spiral 4 (FY 08) involves embedding the DCGS-A capability within the Army's Future Combat System. Spiral 4 will also involve improved software applications, access to external sensor feeds, visualization tools, scaleable analytical tools, and leverage functions and lessons learned from previous Spirals.<sup>85</sup>

The Army participated in the Air Force's preliminary DCGS Block 10.2 coordination meetings which involved the development of the DCGS Integration Backbone. However, they have decided to await the outcome of the Air Force's effort to determine if there is value there for the Army's DCGS-A strategy. The Army wants to ensure that whatever form DCGS-A takes, it must include the functionality of the legacy systems at a minimum.<sup>86</sup>

The GAO report on interoperability previously mentioned in this chapter, looked at six Army systems. The Counterintelligence / Human Intelligence Information Management System is the only system that is tested and certified as interoperable. There are currently no systems in the process of interoperability testing and only the All Source Analysis System Remote Workstation is planned for testing (FY 2003). The Integrated Processing Facility, Home Station

---

<sup>83</sup> Christianson, Mr. Charles. Program Executive Office for Intelligence, Electronic Warfare & Sensors. Briefing to the Armed Forces Journal ISR Symposium. 21 November 2002.

<sup>84</sup> Ibid.

<sup>85</sup> Ibid.

<sup>86</sup> E-mail from Mr Thom Revay. Army Space Programs Office. 23 May 2003.

Operations Center, Tactical Exploitation System, and Guardrail Information Node have no plans for interoperability testing.<sup>87</sup>

#### D. MARINE CORPS ISR

The Marine Corps calls its battlefield intelligence system the Marine Corps Air Ground Intelligence System (MAGIS) (Figure 11). The MAGIS network provides the capability to collect, process, analyze, fuse, and disseminate information derived from organic intelligence sources (IMINT, SIGINT, MASINT and HUMINT) as well as some theater and national systems. This architecture meets threshold DCGS requirements as outlined in the DoD DCGS CRD.<sup>88</sup>

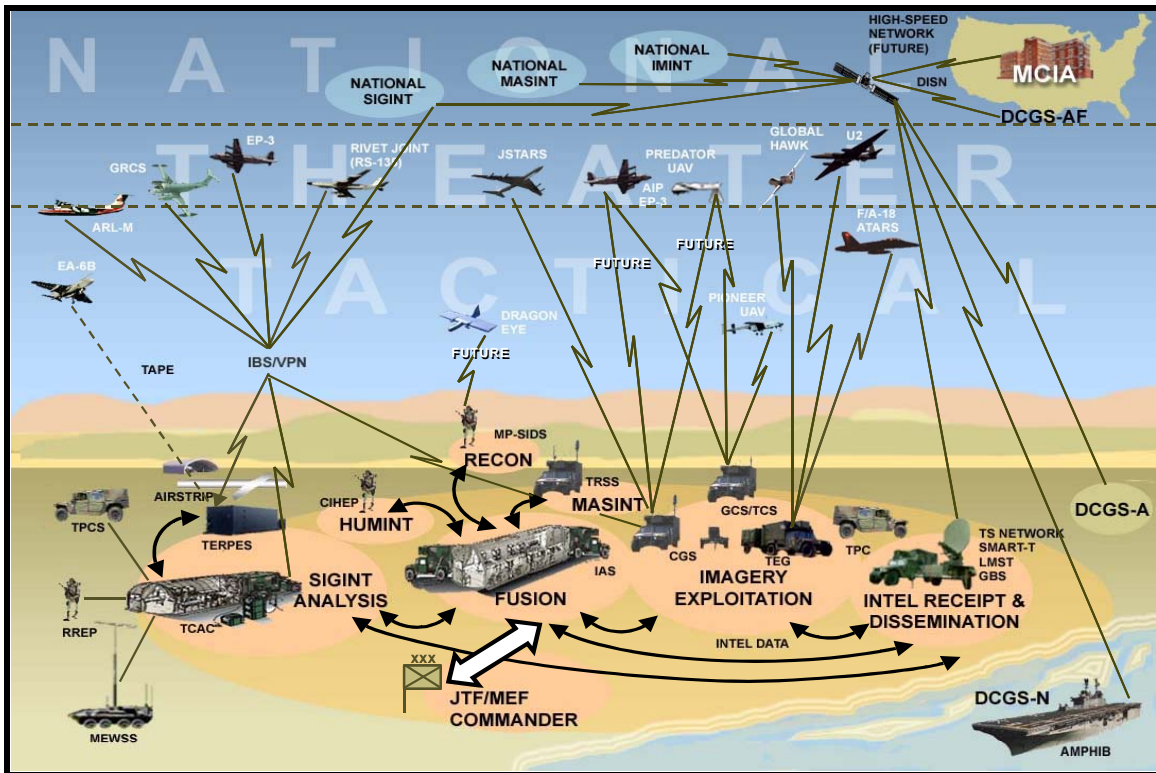

Figure 11. Marine Air Ground Intelligence System<sup>89</sup>

<sup>87</sup> GAO Report. p. 12.

<sup>88</sup> Marine Corps Air Ground Intelligence System (MAGIS) information pamphlet. Intelligence Department, Headquarters USMC. Arlington, VA. July 2002.

<sup>89</sup> Ibid.

The Marine Corps' capstone warfighting concept for the 21<sup>st</sup> century is contained in its Expeditionary Maneuver Warfare (EMW) concept. This concept stresses strategically agile and tactically flexible Marine Air-Ground Task Forces (MAGTFs) with the operational reach to project relevant and effective power across the depth of the battlespace. MAGIS is specifically designed to support EMW by providing Marine Commanders with all-source, fused intelligence necessary to make informed decisions rapidly. MAGIS is designed to be scaleable and transportable across the battlefield to support the different sizes, missions, and unique requirements of MAGTFs.<sup>90</sup>

The centerpiece of the Marine Corps' ISR systems is the Intelligence Analysis System (IAS). The IAS fuses intelligence data from various sources and databases and provides Marine Air-Ground Task Force (MAGTF) intelligence activities with direction in collection, processing, production and dissemination of critical tactical intelligence. Inter-operability with other systems such as the Global Command and Control System - Integrated Imagery and Intelligence (GCCS-I3), the Navy Tactical Command System-Afloat (NTCS-A), Joint Deployable Intelligence Support System (JDISS), the Air Force Theater Battle Management Core System (TBMCS), parts of the Army's All Source Analysis System (ASAS), Tactical Exploitation System (TES) and all Marine Air Ground Intelligence systems is maintained to ensure a common intelligence picture of the battlefield. The IAS configuration also provides administrative support through the use of word processing, graphics, spreadsheet, and data base management programs.<sup>91</sup>

The IAS architecture is scalable from a single, stand alone, portable workstation at the battalion/squadron level; to a four station, on line, moveable, intermediate suite at the Marine Expeditionary Unit (MEU) level; to a mobile mounted multi-station real time, service-wide intelligence communications link at the Marine Expeditionary Force (MEF) level. The IAS will deploy either as a MEF IAS or as single IAS workstations. The MEF IAS serves as the hub for MAGIS. It provides intelligence functionality tailored for each echelon's all-source intelligence fusion centers and is compatible with the DII-COE standards. The MEF IAS is a shelterized,

---

<sup>90</sup> Ibid.

<sup>91</sup> Federation of American Scientists (FAS) website. [[www.fas.org/irp/program/core/ias.htm](http://www.fas.org/irp/program/core/ias.htm)]. May 2003.

mobile system with multiple analyst workstations in a client-server LAN configuration. IAS suites, for intermediate commands, are configured in either a two or a four workstation LAN.<sup>92</sup>

The IAS relies on several other systems to serve as its primary source of intelligence information. These systems are:<sup>93</sup>

- Tactical Exploitation Group (TEG)- IMINT
- Technical Control and Analysis Center (TCAC)- SIGINT
- Tactical Remote Sensor System (TRSS)- MASINT
- JSTARS Common Ground Station (CGS)- GMTI
- Trojan Spirit II and Trojan Spirit Lite Network- National Intelligence data

In the future, the IAS is projected to have the capability to receive EP-3, Predator, Shadow and Pioneer UAV imagery through the Tactical Control Station (TCS).<sup>94</sup>

Although the Marine Corps' TEG system is based on TES, it is not employed like the Army or Navy's TES system. TEG is an imagery exploitation centric system which resides in the Marine Corps' imagery exploitation organization. However, the Marine Corps uses some of the multi-intelligence capabilities of TES workstations and software to assist with imagery queuing only. Also, the TEG also operates only at the collateral SECRET level where the Army and Navy TES operate at the SCI and collateral SECRET levels.<sup>95</sup>

The TCAC provides automated processing, analysis, and reporting of SIGINT information in support of MAGTF operations. The TCAC fuses SIGINT information from tactical, theater and national collectors.<sup>96</sup>

The GAO report on interoperability previously mentioned in this chapter, looked at seven Marine Corp systems. The TEG was partially tested in October 2002 with out any results published. There is also no further testing of the TEG scheduled for FY 2003 due to operational needs. The IAS and TCAC are scheduled for testing in FY 2004.<sup>97</sup>

---

<sup>92</sup> Ibid.

<sup>93</sup> MAGIS Pamphlet.

<sup>94</sup> Ibid.

<sup>95</sup> LtCol Gran (Program Manager Intel Systems, Marine Corps Systems Command) briefing to the Joint Forces Command working group on TES & USAF DCGS 10.2. March 03.

<sup>96</sup> Ibid.

<sup>97</sup> General Accounting Office. p. 12-13.

## **E. CHAPTER SUMMARY**

All of the services have TES, but it plays a different role in each service's ISR organization. Whether as an ISR manager, display system, or queuing system, the services have taken the functionality provided by TES and adapted it to meet their needs.

The services also have taken the DCGS guidance provided by DoD and are currently working on making their own systems interoperable in the near-term with the intention of making their systems interoperable with the rest of the DoD DCGS system in the far-term.

The Air Force's Block 10.2 Multi-INT Core acquisition opened the door for true interoperability in the future. With each of the services in on the "ground floor" of defining the Backbone requirements, the potential for developing a DoD wide DCGS system, which can truly share all information, is closer to being a reality.

## IV. JFN DESCRIPTION

The Joint Fires Network (JFN) was initially developed by combining three existing Navy systems: Global Command and Control System – Maritime (GCCS-M), Joint Service Imagery Processing System – Navy (JSIPS-N), and Tactical Exploitation System – Navy (TES-N). These systems perform various tasking, processing, exploitation, and dissemination (TPED) functions in support of naval operations. When they were first developed, these systems provided stove-piped functionality to meet specific needs. By bringing them together into a single family of systems with increased interoperability and collaboration among component systems, JFN improved the flow of information and intelligence while enhancing joint and combined warfighter capabilities. In particular, the collection of capabilities provided by JFN include the following:<sup>98</sup>

- Real-time receipt, display and screening of tactical imagery and video sensors
- Near real-time receipt and display of national imagery
- Precision mensuration for precision-guided munitions (PGMs)
- Geo-registration, warping and annotation of imagery
- Multi-Source information management, data correlation and display at multiple security levels
- Association of tracks with dynamic intelligence database entities
- Dissemination of situational awareness data and targeting information across platforms and joint systems through extensive communications interfaces

This chapter will examine the components that make up JFN and the Navy's effort to define its ISR requirements.

---

<sup>98</sup> Navy Warfare Development Command. TACMEMO 2-01.1-02. *Naval Fires Network*. 01 September 2002. p. 1-1.



Interoperability with other service/joint C4I systems (e.g., Theater Battle Management Core System [TBMCS], Joint Global Command and Control System [GCCS], and Intelligence Analysis System [IAS]) and Naval combat systems (e.g., Advanced Tomahawk Weapon Control System [ATWCS], Tactical Tomahawk Weapon Control System [TTWCS], MIW [Mine Warfare] and Environmental Decision Aids Library [MEDAL]) is achieved through compliance with the Defense Information Infrastructure Common Operating Environment (DII-COE) standards or numerous other interfaces.<sup>101</sup>

Surface ships generally deploy with one of two GCCS-M configurations: a force-level capability (Numbered Fleet Flagships, CVNs, LHDs, and LHAs) or a unit-level capability. In either configuration, one workstation is normally designated the master for communications, and one workstation is normally designated the master Track Database Manager (TDBM) and all other workstations operate as clients.<sup>102</sup>

GCCS-M provides the following functionality to JFN:<sup>103</sup>

- Multi-source information management, data correlation, and display.
- Dissemination of the COP across platforms and with joint systems through extensive communications interfaces.
- Association of tracks with relational database (DB) entities (imagery and intelligence DB records)
- MIDB replication, update, and analysis tools
- ELINT and COMINT reports accepted, included in visualization, and where appropriate translated into tracks
- Request, receipt, storage, and visualization of secondary imagery
- Non-real time receipt, display, and screening of unmanned aerial vehicle (UAV) video.
- Two-way interface with TADIL networks.

---

<sup>101</sup> Ibid. p. 1-2.

<sup>102</sup> Ibid. p. A-1.

<sup>103</sup> Ibid. p. 1-2.



## B. JOINT SERVICE IMAGERY PROCESSING SYSTEM – NAVY

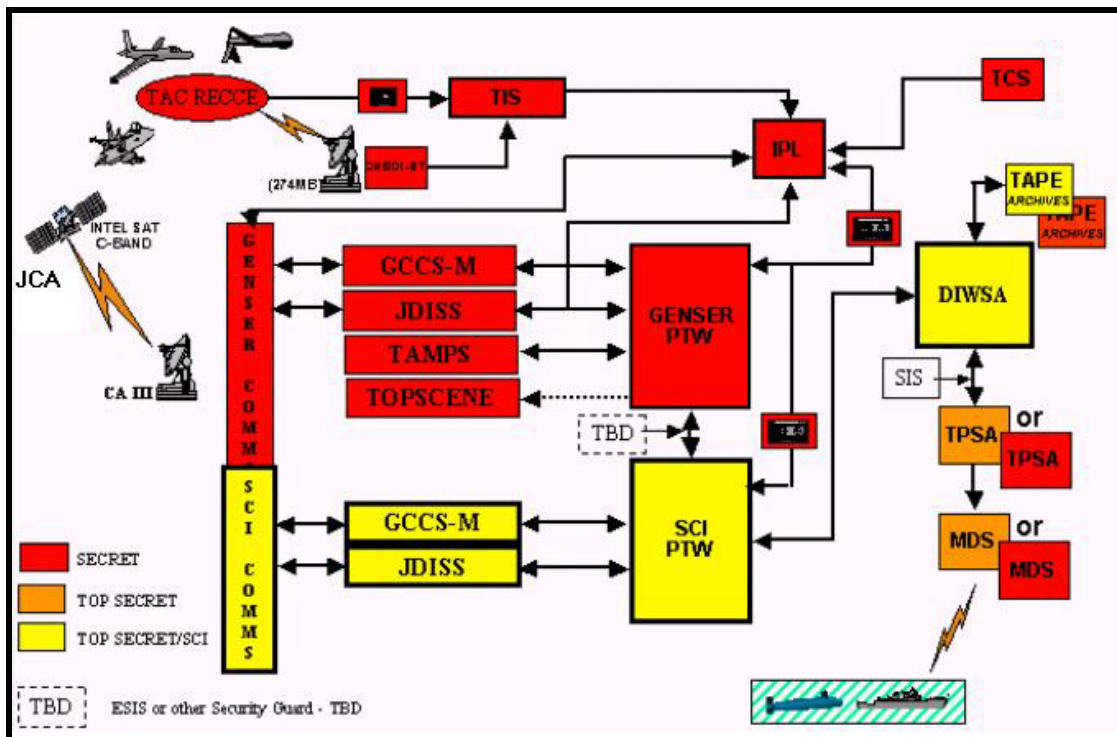

Figure 13. JSIPS-N Version 3.1/3.2 Architecture<sup>104</sup>

JSIPS-N (Figure 13) is a cornerstone system for intelligence support of targeting conducted on carriers, large deck amphibious assault ships, command ships, and shore sites supporting operational, training and test activities. JSIPS-N provides the capability to receive imagery from national and tactical sources in a variety of formats and to create precise and accurate imagery information products (such as Target Aimpoint Graphics, Electronic Target Folders (ETFs), and Desired Mean Points of Impact (DMPIs)), which are tactically and operationally significant. It provides imagery exploitation and targeting for PGMs in support of tactical aircraft strike. In addition, JSIPS-N imagery exploitation and target folder services support TLAM strike planning.<sup>105</sup>

<sup>104</sup> Ibid. p. A-7.

<sup>105</sup> Ibid. p. 1-3.

Shipboard interfaces include GCCS-M, Tactical Aircraft Mission Planning System (TAMPS), and the Afloat Planning System (APS). JSIPS-N also interfaces with external intelligence databases/ data sources and joint mission planning systems via various communications channels.<sup>106</sup>

JSIPS-N provides the following functionality to JFN:<sup>107</sup>

- Non-real time ingest and processing of national imagery
- Real-time to non-real time ingest and processing of Common Datalink-Navy (CDL-N) supported tactical sensor imagery, to include FA-18 Shared Reconnaissance Pod (SHARP) data
- Imagery exploitation, geo-registration, archival and secondary dissemination services
- Mensuration and precision geopositioning services supporting all PGM weapons employment (including Tomahawk)
- Aimpoint and imagery product output to combat/weapons/mission planning systems

### **C. TACTICAL EXPLOITATION SYSTEM – NAVY**

TES-N (Figure 14) is the Navy shipboard implementation of the Army Tactical Exploitation System (TES-A). It is an integrated, scalable, multi-intelligence system specifically designed for rapid correlation of national and theater ISR information to support network centric operations. TES-N provides the warfighting commander with access to near-real time, multi-source, and continuously updated day/night battlespace ISR information. TES-N supports strike operations using numerous ISR collection planning, data correlation, geolocation, data dissemination, and storage functions. It is interoperable with other service derivatives of the TES system: TES-A, the Marine Corp's Tactical Exploitation Group (TEG) and the Air Force's ISR Manager (ISR-M).<sup>108</sup>

---

<sup>106</sup> Ibid. p. 1-3.

<sup>107</sup> Ibid. p. 1-3.

<sup>108</sup> Ibid. p. 1-4.

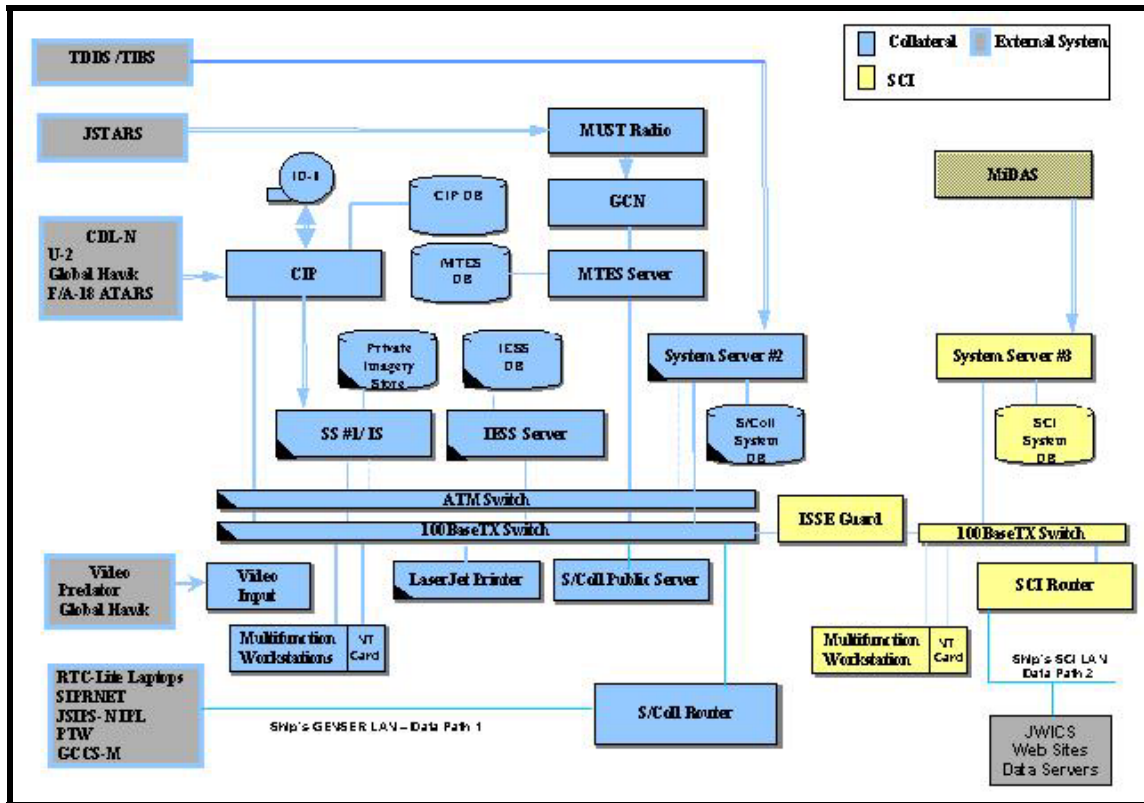

Figure 14. Full TES-N Architecture<sup>109</sup>

Four primary configurations of TES-N are deployed to enable distributed network operations among naval units: Full System, Remote Terminal Component (RTC), Littoral Surveillance System (LSS) and Remote Terminal Component - Lite (RTC-Lite). A full TES-N system contains all the components necessary to conduct operations with various sensor platforms. A full TES-N can be employed as a stand-alone system or as a server supporting multiple RTCs. An RTC is a smaller version of the full system that does not have the workflow management features or the equipment (antennas, processors, etc.) necessary to interface directly with various ISR platforms. However, when connected as a client to a full TES-N system (or to other service TES systems), the RTC is able to remotely control the full system's antennas and processors in order to receive sensor data for local exploitation. The RTC can operate over a wide range of bandwidths to support rapid icon visualization (lower bandwidth) through real time display of imagery products (requires higher bandwidth). A comparison of the capabilities provided by a full TES-N installation versus an RTC installation is provided in Table 8. The

<sup>109</sup> Ibid. p A-14.

LSS integrates the major functions of the Naval Reserve Mobile Inshore Undersea Warfare (MIUW) system with that of the TES-N system. The RTC-Lite is a lightweight, man portable unit that provides a limited Tactical Exploitation of National Capabilities (TENCAP) communications and processing/analysis/reporting (PAR) capability where deployed. RTC-Lite is primarily used as a situational awareness tool that allows TES preprocessed data to be shared in a distributed environment.<sup>110</sup>

	<b>FULL TES-N</b>	<b>RTC SUPPORTED BY TES (1)</b>	<b>AUTONOMOUS RTC</b>
Tactical Imagery (CDL-N) Processing & Exploitation	Yes	Yes (2)	Limited (3)
National Imagery Processing & Exploitation	Yes (3)	Yes (3)	Yes (3)
Video Screening/Capture/Registration	Yes (4)	Yes (4)	Yes (4)
National Technical Means SIGINT	Yes	Yes	Yes (3)
Broadcast SIGINT	Yes	Yes	Yes
Target Geolocation (Non-PGM)	Yes	Yes	Yes
Target Nomination	Yes	Yes	Yes
U-2 Sensor Tasking & Control (ROE/MOA permitting)	Yes	Yes (2)	No
JSTARS SAR/MTI	Yes	Yes (5)	No
GCCS-M Track Interface	Yes	Yes	Yes
Collaborative Tools	Yes	Yes	Yes
Geo-Correlated Multi-INT Display in Near Real-Time	Yes	Yes	Limited (6)
Notes: (1) RTC requires TES support and adequate (min 512K) bandwidth for full performance. (2) Assumes 512K link; performance degraded significantly at less bandwidth. (3) Imagery / NTM SIGINT received and processed by other systems (e.g., JSIPS-N or GCCS-M). Can be forwarded to RTC/TES-N for exploitation. (4) Most video does not come with telemetry data – registration is manual. (5) RTC receives MTI Tracks, not data. No onboard processing. (6) Limited to data sources and tracks able to be received by RTC.			

**Table 8. Full TES-N vs RTC Capabilities Comparison<sup>111</sup>**

TES-N provides the following functionality to JFN:<sup>112</sup>

- Real-time to non-real time ingest and processing of CDL-N supported tactical sensor imagery (excluding FA-18 SHARP data)
- U-2 sensor control, flight track / collection plan visualization and modification
- Non-real time receipt, display, and screening of UAV video

<sup>110</sup> Ibid. p. 1-4.

<sup>111</sup> Ibid. p. A-21.

<sup>112</sup> Ibid. p. 1-4.

- Non-real time receipt and processing of synthetic aperture radar (SAR) and moving target indicator (MTI) data from Joint Surveillance Target Attack Radar System (JSTARS)
- ELINT reports accepted and included in visualization
- Direct access to selected classified sensors
- Multi-intelligence correlated, geo-registered / overlayable displays
- Interoperability with other service TES-based systems

#### D. TIME CRITICAL TARGETING

The following section is provided to support an analysis of JFN’s contribution to time critical targeting by first describing the targeting process and then how JFN contributes to that process.

There are various ways of describing the targeting process and the various intelligence functions that occur within it. Joint Publication 2-01.1 defines the Intelligence Cycle (Figure 15) and the various steps that occur within it as planning and direction, collection, processing and exploitation, analysis and production, dissemination and integration. TPED (tasking, processing, exploitation and dissemination) is another term used to describe the intelligence cycle.<sup>113</sup>

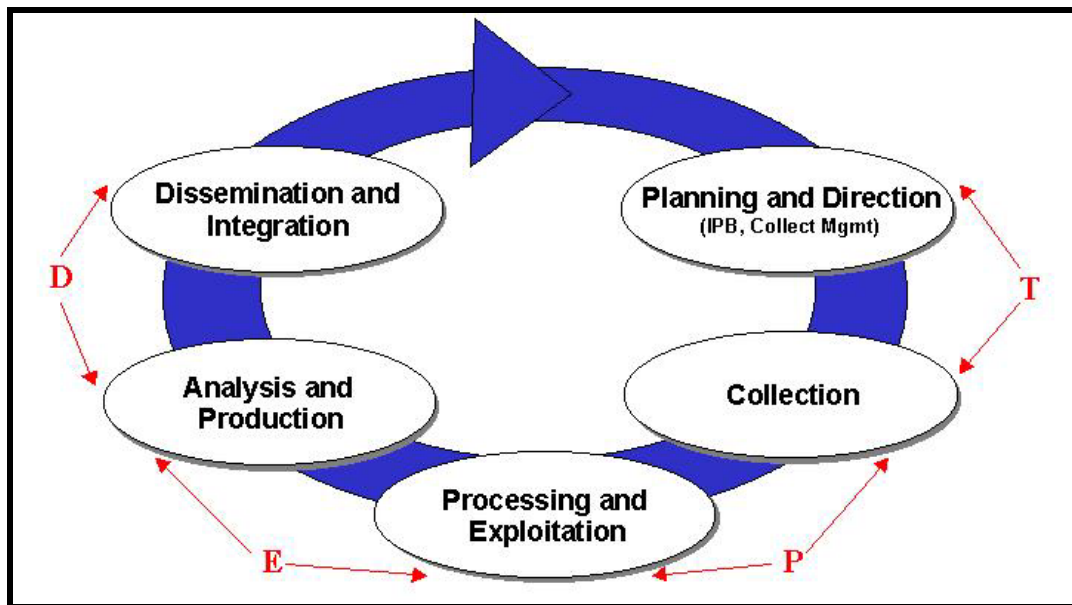
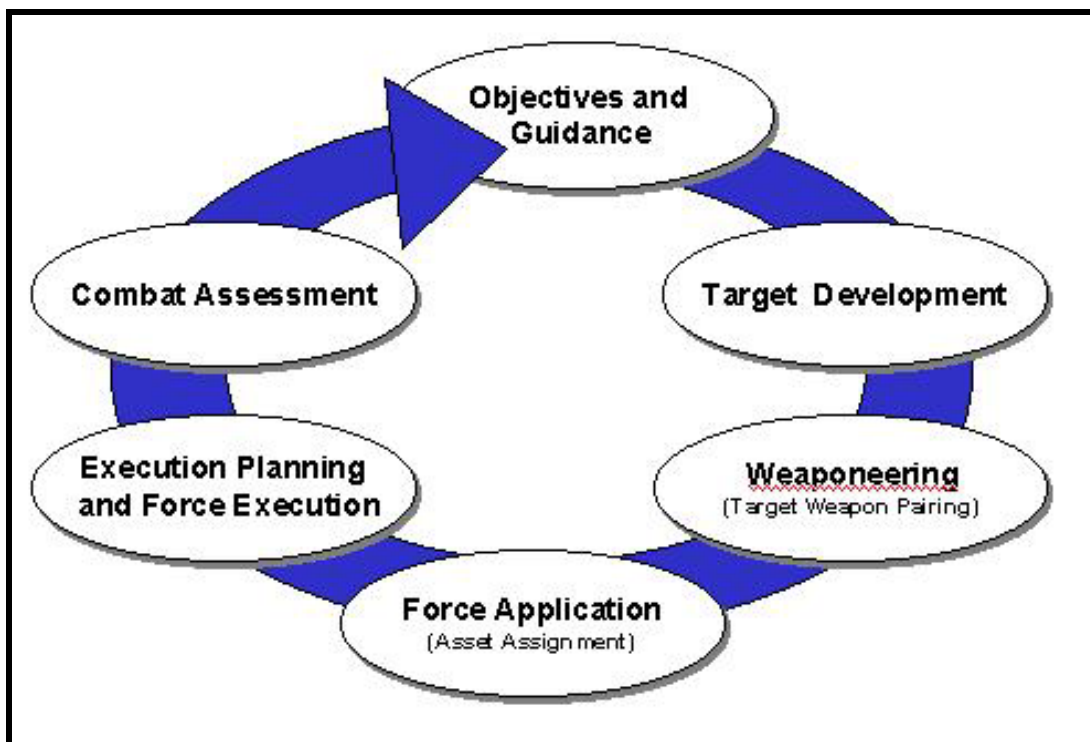

Figure 15. Intelligence Cycle<sup>114</sup>

<sup>113</sup> Ibid. p. 2-1.

<sup>114</sup> Ibid. p. 2-1.

Joint Publication 3-60 defines the Targeting Cycle (Figure 16) and the steps that occur within the targeting process. This is widely accepted as the targeting cycle for the deliberate planning process and each step is clearly observed during operations where an Air Tasking Order (ATO) is generated and executed. The Joint Force Commander's objectives and guidance define the priorities by which a target set is developed. Detailed target to weapon pairing analysis occurs during the weaponeering phase to determine the appropriate means available to destroy those targets. The ATO is generated during the force application phase, where assets are assigned to strike (or support the strike of) designated targets. After detailed mission planning and execution of the task at hand, combat assessment occurs to determine the success or failure of the mission.<sup>115</sup>



**Figure 16. Targeting Cycle<sup>116</sup>**

The intelligence cycle, as described earlier, closely resembles the individual steps that occur within the target development phase of the targeting cycle. Modifying the targeting cycle diagram by insertion of the intelligence cycle produces Figure 17 which provides greater insight

---

<sup>115</sup> Ibid. p. 2-2.

<sup>116</sup> Ibid. p. 2-2.

into the role of intelligence in support of the targeting process. The individual steps on the diagram are numbered to allow for easy recognition of the process, although in real world operations many of these steps often occur in parallel with each other.<sup>117</sup>

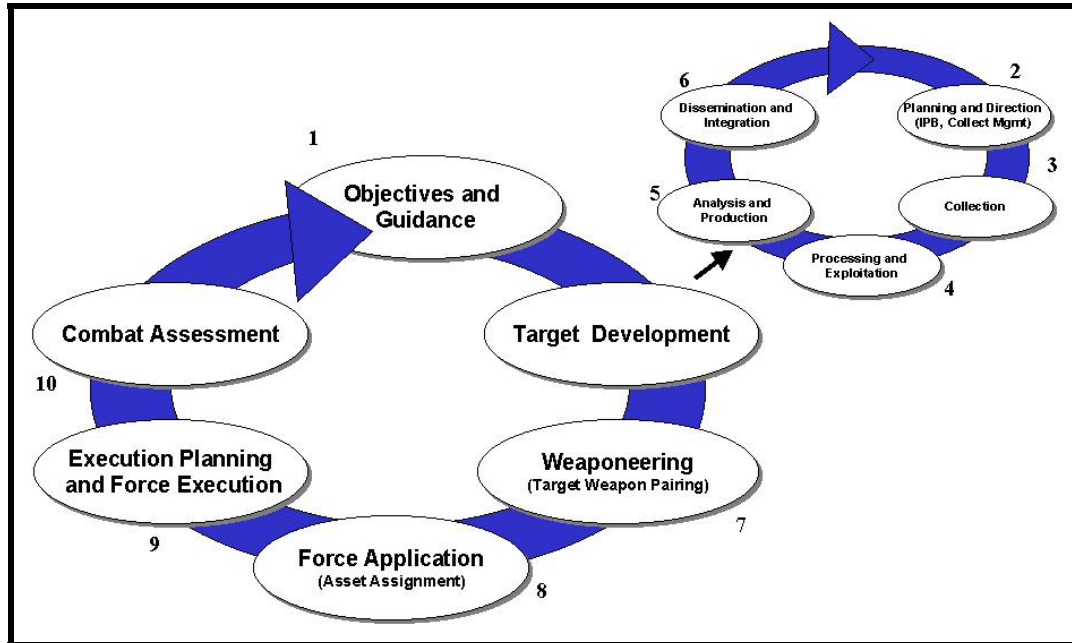

**Figure 17. Intelligence Support to the Targeting Cycle<sup>118</sup>**

In time critical strike operations, the Find, Fix, Track, Target, Engage and Assess (F2T2EA) cycle (Figure 18) is also used to describe the targeting process.

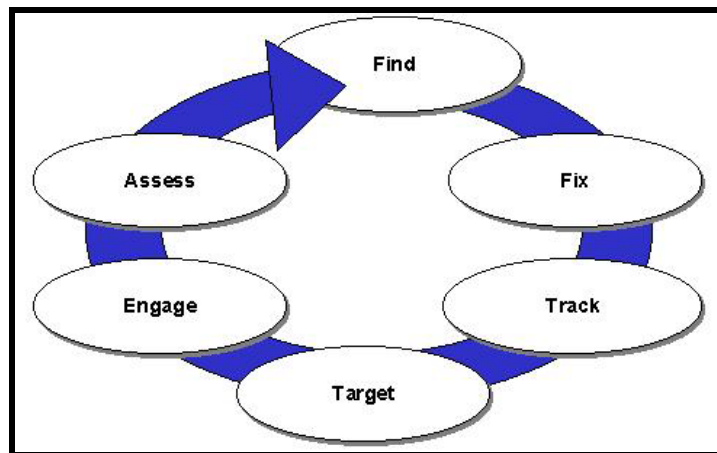

**Figure 18. Time Critical Strike Targeting Cycle<sup>119</sup>**

<sup>117</sup> Ibid. p. 2-2.

<sup>118</sup> Ibid. p. 2-3.

If these time critical targeting steps are superimposed on the intelligence support to the targeting process diagram, Figure 19 results.<sup>120</sup>

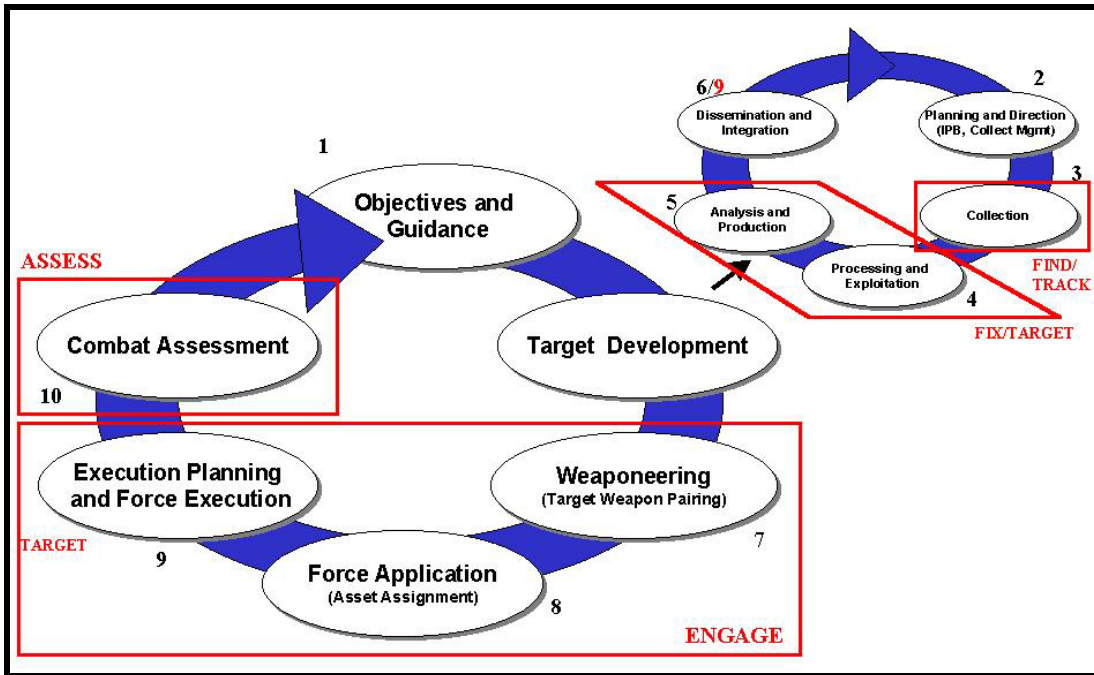

Figure 19. Time Critical Strike Cycle Overlayed onto the Targeting Process<sup>121</sup>

From Figure 19, several observations can be made. First, the JP 3-60 targeting cycle can be viewed within the context of time critical targeting. For example, when a commander decides to engage a time critical target, several subtasks still must be performed: target weapon pairing, asset assignment and mission planning/execution. Second, several steps still need to be addressed when discussing time critical targeting that are not readily apparent from the F2T2EA acronym. Specifically, commander's objectives/guidance, planning/direction and dissemination/integration issues need to be addressed for time critical strike to succeed. Third, the quick dissemination and integration of intelligence data must occur at two different stages

<sup>119</sup> Ibid. p. 2-3.

<sup>120</sup> Ibid. p. 2-3.

<sup>121</sup> Ibid. p. 2-4.



(steps 6 and 9): to the operations officer (who must make engagement decisions) and to the strike asset (once the engagement decision has been made).<sup>122</sup>

When a time critical target is found that meets the criteria established by the Joint Force Commander (JFC), it will be fixed, identified, tracked, and flagged in the COP for engagement. The engagement phase of the time critical target process can be divided into three sub-phases: weaponeering, force application and execution planning / force execution.<sup>123</sup>

The weaponeering assessment process links the desired method of engagement with specific aim points or objectives based on the most current information available. Personnel supporting weaponeering assessment must be thoroughly familiar with the type and quality of information required for completing mission planning for all types of weapons systems, as well as the collateral damage aspects of these systems. The assessment results in recommended numbers and types of weapons, methods and directions of attack, weapons fusing techniques and delivery modes to ensure the objectives are met. Currently, naval forces must conduct this weaponeering assessment manually – there is no target weapon pairing functionality resident within the JFN component systems.<sup>124</sup>

Force application is the decision to attack a particular target and the selection of lethal or non-lethal forces to perform the mission. In the targeting process, this is where the weaponeering assessment is matched to available attack resources. Based on the JFC's intent, guidance, and objectives, component forces conduct force application planning to prosecute the target, develop alternative weapon system solutions, and identify munitions or look at non-lethal force applications. An evaluation is made of available strike assets that are on alert or have been pre-staged for time critical target operations. If necessary, a decision may be made to divert assets already enroute to a preplanned target. Currently, the force application phase is also performed manually based upon all available data – there is no time critical target force application / asset management functionality resident within the JFN component systems.<sup>125</sup>

---

<sup>122</sup> Ibid. p. 2-4.

<sup>123</sup> Ibid. p. 2-46.

<sup>124</sup> Ibid. p. 2-47.

<sup>125</sup> Ibid. p. 2-47.

Using the steps from Figure 19, Table 9 summarizes the current contributions that JFN component systems make to the targeting process.

	<b>TES-N</b>	<b>JSIPS-N</b>	<b>GCCS-M</b>
CDR's Objectives and Guidance	Yes <sup>1</sup>	Yes <sup>1</sup>	Yes <sup>1</sup>
Planning and Direction			
Intel Prep of Battlespace	Yes	Yes	Yes
Collection Planning	Yes <sup>2,3</sup>	Yes <sup>3</sup>	Yes <sup>3</sup>
Find / Track (Direct Sensor Receipt <sup>4</sup> )			
Tactical Imagery (CDL-N)	Yes <sup>5</sup>	Yes <sup>6</sup>	No
Tactical Imagery (Video)	Yes	No	Yes
National Imagery <sup>7</sup>	No	Yes	No
JSTARS	Yes <sup>8</sup>	No	Yes <sup>9</sup>
ELINT	Yes <sup>10</sup>	No	Yes <sup>10</sup>
COMINT	No	No	Yes
Other SIGINT	Yes	No	No
Fix / Target			
Imagery Exploitation	Yes	Yes	No <sup>11</sup>
PGM Quality Mensuration	No	Yes	No
Non-PGM Quality Geolocation	Yes	Yes	No
Target Validation	Yes <sup>1</sup>	Yes <sup>1</sup>	Yes <sup>1</sup>
Target Nomination/Dissemination to C2	Yes	Yes	Yes
Engage			
Target Weapon Pairing	<b>No</b>	<b>No</b>	<b>No</b>
Force Application (Asset assignment)	<b>No</b>	<b>No</b>	<b>No</b>
Execution Planning	No	Yes <sup>12</sup>	No
Force Execution / Targeting			
Target Dissemination to Strike Asset	No	Yes <sup>13</sup>	Yes <sup>14</sup>
Assess	Yes	Yes	Yes
<p>Notes:</p> <ol style="list-style-type: none"> <li>1. If configured with JTT.</li> <li>2. Builds collection plans for U-2 sensors (ROE and inter-service military operating area (MOA) permitting). Predator and Global Hawk collection planning included in TES version 5.x.</li> <li>3. National imagery request via web requirements management system (RMS).</li> <li>4. System is a primary data path for the respective imagery/data. Once received, secondary imagery/data can be passed to other component systems for processing/analysis.</li> <li>5. Full TES-N within LOS of sensor or RTC connected with sufficient bandwidth to Full TES node. Includes U-2 sensor control (ROE and inter-service MOA permitting).</li> <li>6. If configured with TIS component and within LOS of sensor.</li> <li>7. Not suitable for time critical strike dynamic retasking.</li> <li>8. If configured with MTES components.</li> <li>9. If loaded with Naval JSTARS Interface (NJI).</li> <li>10. If TDDS present.</li> <li>11. Imagery/video display only. Does not include ELT exploitation tools.</li> <li>12. Direct TLAM planning. Connection to external strike planning programs (TAMPS, etc.). Strike Planning Folder for air tasking order (ATO) missions only.</li> <li>13. All PGMs (to include TLAM).</li> <li>14. Via Multi-TADIL Capability.</li> </ol>			

**Table 9. JFN Component Support to Time Critical Targeting<sup>126</sup>**

<sup>126</sup> Ibid. p. 2-5.

## E. JFN ISR CAPABILITIES

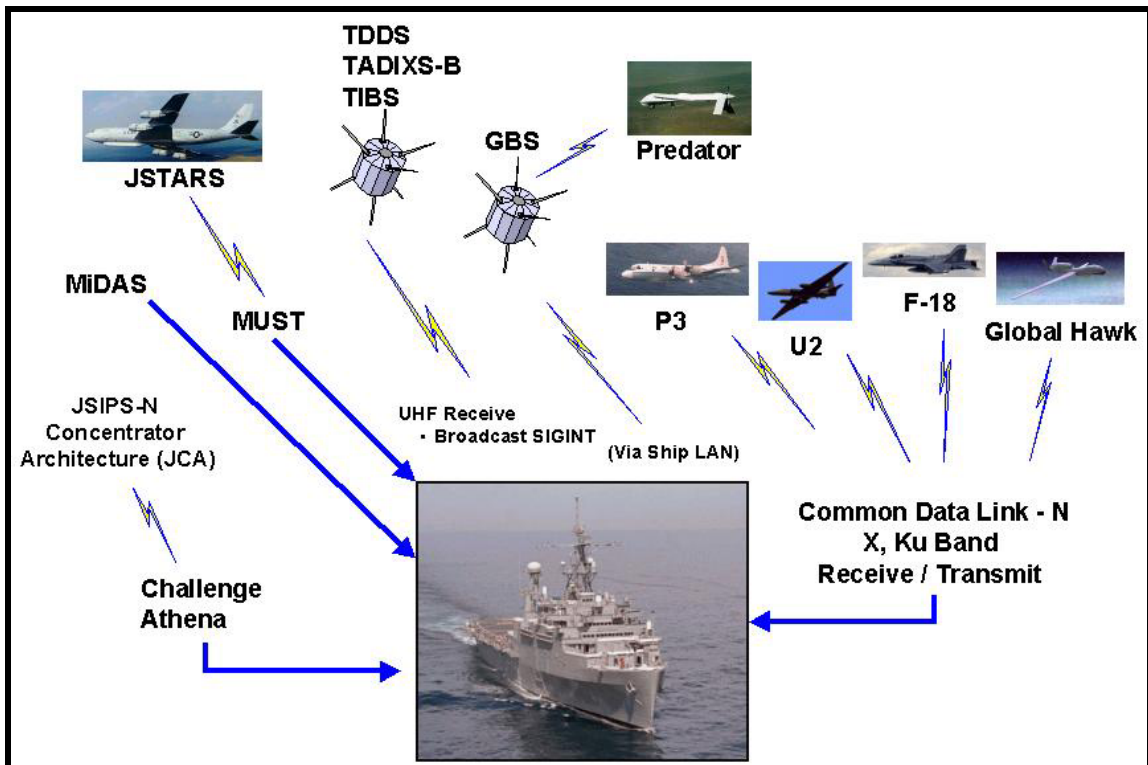

Figure 20. JFN Sensor Inputs<sup>127</sup>

The systems which make up JFN provide significant capabilities for collecting, analyzing, and developing aimpoints from ISR information (Figure 20). This section will address some of these capabilities.

### 1. Imagery

JSIPS-N is the primary national imagery dissemination system afloat. Operators can attempt to fulfill national imagery requirements by searching through image archives on the local Image Products Library (IPL), Precision Targeting Workstation (PTW), or Digital Imagery Workstation (DIWS) (a component of JSIPS-N). If imagery is not available within local archives, the unit can pursue the imagery request as a target in the JSIPS-N Concentration Architecture (JCA) Imagery Exploitation Support System (IESS) server which will search for an existing image either on another JSIPS-N platform in theater or in CONUS.<sup>128</sup>

<sup>127</sup> TACMEMO. p. 2-17.

<sup>128</sup> Ibid. p. 2-8.

The JCA IESS server maintains a database of fleet-wide local imagery / target coverage requirements and performs the brokering between the JCA and the National Technical Means (NTM) source to determine what is available versus what is desired by each remote user site.<sup>129</sup>

Both TES-N and JSIPS-N are capable of receiving sensor data from Common Data Link – Navy (CDL-N) compliant platforms such as U-2, F/A-18, F/A-18D, and Global Hawk. The Tactical Input Segment (TIS), which is a component of JSIPS-N, is also capable of receiving and processing F/A-18E/F Shared Airborne Reconnaissance Pod (SHARP) data (imagery).<sup>130</sup>

JSIPS-N, as shown in Figure 21, provides the capability to receive real time and non-real time imagery from multiple sources, process the imagery, and rapidly develop an aimpoint on the PTW. The aimpoint is then passed to a shooting platform via several possible systems.<sup>131</sup>

Both TES-N and JSIPS-N are capable of receiving imagery directly from tactical and theater airborne reconnaissance systems. JSIPS-N is also capable of receiving imagery derived from NTM. Two national imagery formats currently exist – National Imagery Transmission Format (NITF) and Tape Format Requirements Device (TFRD). Both national formats contain metadata (precise location data, etc.) related to the pixels of the image, greatly increasing its exploitation value. NITF and TFRD formats are supported by JSIPS-N for receipt, storage, display and secondary dissemination (electronically or via magnetic media). GCCS-M and TES-N, however, do not support the display of TFRD imagery – all files transferred from JSIPS-N to these systems must be converted to NITF 2.0 format.<sup>132</sup>

---

<sup>129</sup> Ibid. p. 2-8.

<sup>130</sup> Ibid. p. 2-11.

<sup>131</sup> Washington Planning Center. Briefing on JSIPS-N System. 06 February 2003.

<sup>132</sup> TACMEMO. p. 2-18.

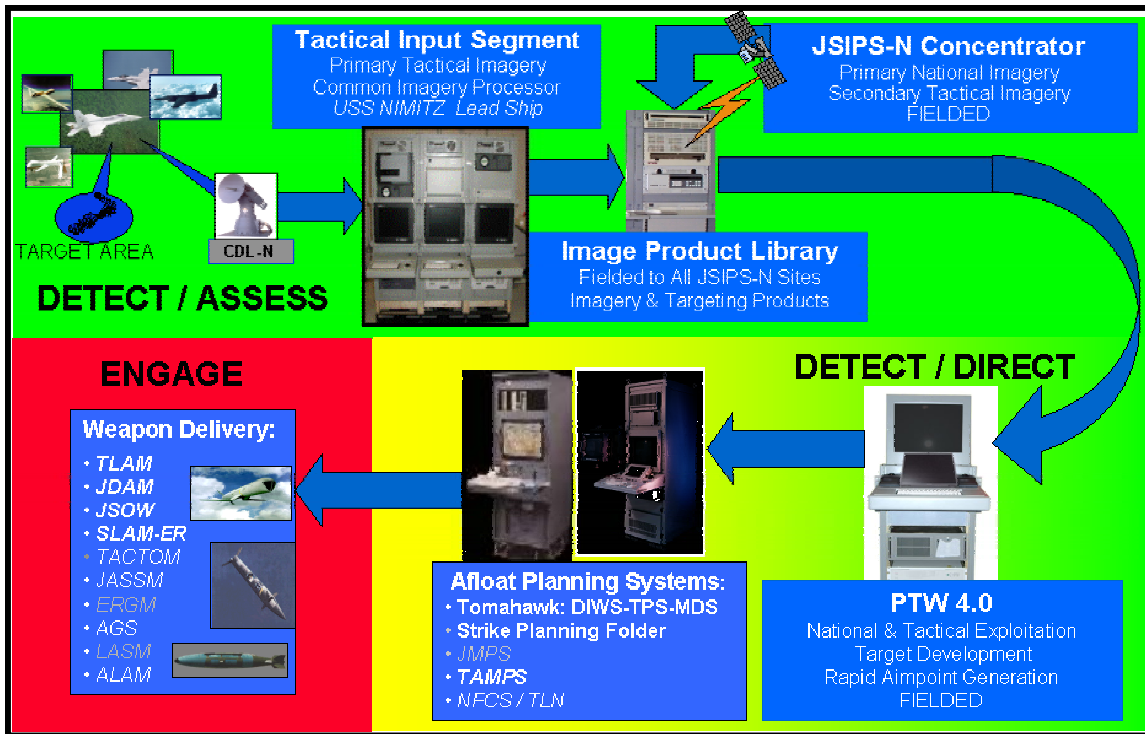

Figure 21. JSIPS-N Architecture<sup>133</sup>

## 2. JSTARS

The Joint Surveillance Target Attack Radar System (JSTARS) is a long-range, air-to-ground surveillance system designed to locate, classify and track ground targets in all weather conditions. JSTARS consists of an airborne platform – an E-8C aircraft with a multi-mode radar system – and joint ground stations capable of processing downlinked tactical data. Radar operating modes include wide area surveillance, moving target indicator (MTI), fixed target indicator (FTI) target classification, and synthetic aperture radar (SAR). The antenna can be tilted to either side of the aircraft where it can develop a 120-degree field of view covering nearly 19,305 square miles (50,000 square kilometers) and is capable of detecting targets at more than 250 kilometers (more than 820,000 feet). In addition to being able to detect, locate and track large numbers of ground vehicles the radar has some limited capability to detect helicopters, rotating antennas and low, slow-moving fixed wing aircraft. The SAR system may be used in conjunction with the MTI system to provide a display of MTI data over SAR to increase situational awareness and confirmation of Ground Moving Target Indicator (GMTI) -

<sup>133</sup> Ibid.

detected targets. Both TES-N (configured with a Moving Target Exploitation System [MTES]) and GCCS-M (configured with a Naval Joint STARS Interface [NJI]) are capable of receiving and processing JSTARS MTI data. Only TES-N, however, can directly receive and process JSTARS SAR imagery.<sup>134</sup>

### 3. ELINT

ELINT data enters the NFN architecture either from broadcast networks or via network file transfer. There are several near real-time tactical broadcasts available to military forces, which include, but are not limited to:<sup>135</sup>

- **Tactical Related Applications (TRAP) Data Dissemination System (TDDS).** A worldwide UHF SATCOM broadcast of high-interest ELINT, contact reports, and parametric information at the SECRET collateral level. The TRAP equipment receives these reports from a number of sources and reformats the data into Tactical Data Information Exchange System-Broadcast (TADIXS-B) format for transmission. Naval units receive this data via shipboard Tactical Receive Equipment (TRE), where incoming data can be filtered by area of interest and other user-defined criteria using the Standard Tactical Receive Equipment Display (S-TRED). TDDS is also known as Integrated Broadcast Service (IBS) Simplex.
- **Tactical Information Broadcast System (TIBS).** A theater line-of-sight and UHF SATCOM interactive network of threat situational awareness data at the SECRET collateral level. TIBS can support up to 10 producers, 50 query nodes, and an unlimited number of receive-only users. In order to receive TIBS information, a TIBS node requires a satellite communications receiver and/or transmitter, a message processor, and a graphics display. TIBS terminals are typically deployed as part of a C2 unit or at the Air Operations Center [AOC] level, and are a theater asset used by the Air Force Rivet Joint platform. TIBS is also known as IBS Interactive.
- **Tactical Reconnaissance Intelligence Exchange System (TRIXS).** A line-of-sight (LOS), UHF interactive network that transmits messages in near-real-time to up to 250 addressees. The TRIXS operates at the SECRET collateral and SCI levels. TRIXS currently supports the following airborne relays and producers: 1) Army's Guardrail Common Sensor (GRCS) on board the RC-12 aircraft, 2) Air Force Contingency Airborne Reconnaissance System (CARS) on board the U-2, 3) Army's Airborne Reconnaissance Low (ARL) on the DHC-7, and the Navy's Storyteller (EP-3 / E-8).
- **MIDAS.** An SCI level system processed by the TES-N system.

---

<sup>134</sup> Ibid. p. 2-29.

<sup>135</sup> Ibid. p. 2-32.

Both GCCS-M and TES-N have the capability to receive and process ELINT data. Both systems have various ELINT correlators and processors, including Gale LITE, used for analysis and display.<sup>136</sup>

#### 4. TES-N Integrated Tactical Display

The TES-N Integrated Tactical Display (ITD) is an ArcView-based application within TES-N that provides a single integrated display of Cross-INT data, U2 navigation and collection plans, image wire frames, and map wire frames overlaid upon imagery and maps. Using the TES-N ITD, an operator can create target nominations, manual contacts, reference points, and combined object data types.<sup>137</sup>

Unlike the traditional NTDS symbology used by GCCS-M, TES-N uses Graphical Situation Display (GSD) symbols. A GSD tactical symbol (Figure 22) is composed of a frame, fill, and icon and may include text and/or graphic modifiers that provide additional information. The frame attributes (i.e., affiliation, battle dimension, and status) determine the type of frame for a given symbol. Fill color is a redundant indication of the symbol's affiliation. A GraphRep is an overlay that contains specific GSD symbols.

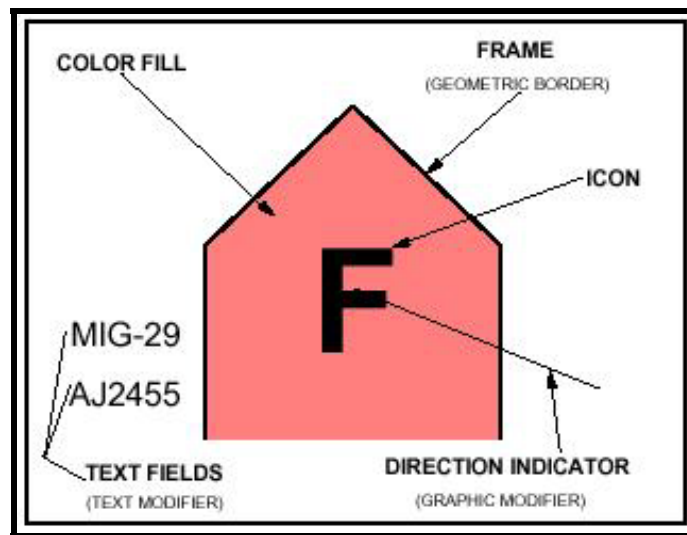

Figure 22. GSD Tactical Symbology<sup>138</sup>

<sup>136</sup> Ibid. p. 2-33.

<sup>137</sup> Ibid. p. 2-44.

<sup>138</sup> Ibid. p. 2-44.

One of the strengths of the TES-N ITD is its ability to allow operators to enable and disable display of various layers of Cross-INT information on top of each other so that tracks can be correlated and greater situational awareness can be attained (Figure 23). The Cross-INT Overlay displays Imagery Interpretation Reports (IIRs), SIGINT, track information, and imagery on top of a map display. While multiple layers can be viewed for correlation purposes, TES-N does not allow analysts to “fuzze” correlated tracks into a single track.<sup>139</sup>

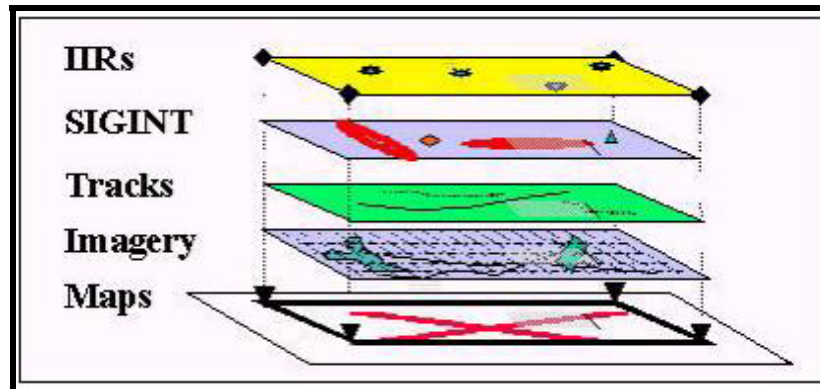

**Figure 23. Cross-INT Overlays<sup>140</sup>**

Cross-INT operations enable the operator to define filter criteria for a query of any combination of IMINT data, GRAPHREP data, or SIGINT data. The TES-N analyst has the capability to overlay this data on top of any system map product or NITF image in the TES-N library. Clicking an icon displays detailed information associated with it, such as ELINT parametrics. Text reports can also be displayed. Geographic and temporal modeling tools compliment the analyst’s capabilities to perform functions such as assessment of target movement and line-of-sight or force limitation analysis. GraphReps can be generated as a result of these analyses using a GSD icon palette. These GRAPHREPS can then be stored in the system Cross-INT database and/or disseminated to external GSD-compatible applications (e.g., Remote View and EMPS) or to other units with TES systems.<sup>141</sup>

Users can also use the TES-N ITD to create shape files. These files are normally lines and polygons used to display geographic boundaries or to highlight specific areas of user

---

<sup>139</sup> Ibid. p. 2-45.

<sup>140</sup> Ibid. p. 2-45.

<sup>141</sup> Ibid. p. 2-45.



interest. Users can create shape files manually in the TES-N ITD, import shape files created by others, or import tab delimited text files (created by standard spreadsheet programs), which are then transformed into shape files.<sup>142</sup>

The TES-N ITD is best described as a situational awareness tool and not as a full-fledged COP. One of the limitations of the TES-N ITD is its lack of a multi-unit synchronization mechanism. Users can manually disseminate cross-INT data to other TES units in theater. However, data entered at a lower echelon unit and forwarded to a higher echelon is not automatically forwarded to all other lower echelons. The operational picture viewed by multiple units may be manually shared, but it is not necessarily “common.”<sup>143</sup>

By establishing an interface between TES-N and GCCS-M, GCCS-M can accept some TES-N data (specifically MTI, manual contacts and reference points) that enhances fleet situational awareness, and TES-N can accept GCCS-M friendly force track data to help analysts correlate Cross-INT track data. GCCS-M CST functionality allows the dissemination of TES-N-generated tracks to non-TES-equipped commands that do have one of the GCCS family of systems. Additionally, this capability can be used locally within a given afloat platform to disseminate non-TES-generated tracks (e.g., TDDS-derived, SCI-derived, Blue Force, or MIDB-derived) to TES-N.<sup>144</sup>

## **5. Multi-Service Operations**

Sequencing, coordination, deconfliction, and synchronization of time sensitive strike with other military operations is important and can occur across a full range of independent, Joint and combined military operations. JFN component systems are designed to be compatible with other service systems as described below.<sup>145</sup>

TES-N uses a common software application baseline to interface with other service TES-based systems. This commonality enables the Naval commander to share real-time battlespace awareness rapidly and seamlessly with other services and to participate fully in Joint collaborative prosecution of time critical targets. TES-N and LSS are functionally identical to

---

<sup>142</sup> Ibid. p. 2-45.

<sup>143</sup> Ibid. p. 2-45.

<sup>144</sup> Ibid. p. 2-45.

<sup>145</sup> Ibid. p. 2-49.

and interoperable with TES-Army (TES-A). The Marine Corps employs the TEG system, which focuses on an imagery-only functionality but also allows ingest and dissemination of ATARS data throughout the TES-N network. The Air Force is employing the TES operating system in the ISR Manager (ISR-M). DIOP sessions can be configured between these systems so that non-real time sensor data can be exploited among multiple services. Database replication and the passing/sharing of Cross-INT data is also supported.<sup>146</sup>

TES-N is also able to send targeting information (via ATI.ATR message format) to the Advanced Field Artillery Tactical Data System (AFATDS). AFATDS is the fire support component of the Army's Battle Command System. AFATDS is the Army and U.S. Marine Corps' single tool for the planning, coordination and control of all fire support assets (mortars, close air support, naval gunfire, attack helicopters, offensive electronic warfare, field artillery cannons, rockets and guided missiles fires). AFATDS reduces engagement time by automatically implementing detailed commander's guidance on many critical tasks for operational planning, movement control, targeting, and fire support planning. The AFATDS system includes automated integration with the Air Force's Theater Battle Management Core System (TBMCS).<sup>147</sup>

The COP data used and displayed within GCCS-M is compatible with the COP data used in all other Joint C4I systems including GCCS at Combatant Commanders and theater SOF Headquarters, TBMCS used by JFACC, and GCCS-A used by US Army Echelon Above Corps units. MIDB replication software synchronizes data updates among the various MIDB users. In other words, national updates made at the responsible producers sites are replicated worldwide to tactical users of GCCS, GCCS-M, TBMCS, IAS, and GCCS-Army systems. Additionally, locally produced tactical updates made by any of those same systems are replicated up-echelon to the theater CINCs for validation and approval and distribution to all components. Experience has shown that worldwide replication typically occurs within several minutes of approval by the responsible producer/validator of that data.<sup>148</sup>

---

<sup>146</sup> Ibid. p. 2-49.

<sup>147</sup> Ibid. p. 2-50.

<sup>148</sup> Ibid. p. 2-50.

The JSIPS-N IPL can connect to the IPL of other services for national, tactical imagery and exploited imagery products.<sup>149</sup>

Finally, as the name suggests, the Joint Targeting Toolbox (JTT) is designed to support multi-service operations. It is used to translate Commanders Intentions/Guidance into Candidate Target Lists (CTL) and Target Nomination Lists (TNL) at every echelon of command. Once the TNL is approved by the combatant commander, JTT permits the sharing of the TNL to all the components for early access to assigned missions for strike planning. JTT also contains Automated Target Folders (ATF), which can be shared among the components and theater intelligence centers to allow a distributed approach to populating the targeting data within these folders. These folders pull updated targeting, weaponeering, and other force disposition information from the MIDB, each time they are re-opened. The aforementioned data replicated among MIDB users also includes this targeting and weaponeering information.<sup>150</sup>



#### **F. JFN ROADMAP**

The original JFN architecture developed by combining JSIPS-N, GCCS-M, and TES-N has proven successful as a near term solution. However, as depicted in Figure 24, there is some overlap in capabilities between these three systems which results in some inefficiencies and requires a larger system footprint than what would be possible if some equipment could be combined.

---

<sup>149</sup> Ibid. p. 2-50.

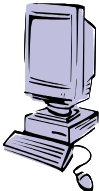
<sup>150</sup> Ibid. p. 2-50.

SENSOR INTERFACES		GCCS-M	JSIPS-N	TES-N	CA
 ISR MANAGEMENT	U-2 Sensor Control				
	BGPHERS	X			GCCS
	EO/IR/SAR			X	TES
 INTEL EXPLOITATION	Natl Imagery Receipt		X		JSIPS
	Natl Imagery Exploitation		X	X	JSIPS & TES
	Tactical Imagery Receipt		X	X	Undecided
	Tactical Imagery Exploitation		X	X	JSIPS & TES
	ELINT Processing	X		X	GCCS & TES
	COMINT Processing	X			GCCS
	Other SINGINT Processing			X	TES
	Track Display	X		X	GCCS & TES
	Track Management	X			GCCS
	Multi-INT Correlation	X		X	GCCS & TES
	Image Archive (Ashore)		X		JSIPS
	Image Archive (Afloat)		X	X	JSIPS & TES
MTI	X		X	GCCS & TES	
Workflow Manager (ISR)			X	TES	
 COMMANDER'S DECISIONS/FORCE ASSIGNMENT	Command & Control	X			GCCS
	Target/Weapon Pairing				
	Mission Planning Interface		X	X	JSIPS
 PRECISION TARGETING & SENSOR PLANNING	PGM Quality Mensuration		X		JSIPS
	Non-PGM Geolocation		X	X	JSIPS & TES
	Target Generation		X	X	JSIPS
	Workflow Manager (Target)		X		JSIPS
WEAPONS INTERFACES	Tactical A/C Up Link	X		X	GCCS & TES

**Figure 24. NFN Architecture Functional Overlaps<sup>151</sup>**

Key to using the JFN systems to provide sensor-to-shooter connectivity inside time critical targeting timelines is development of significantly improved interfaces, connectivity, and convergence of the three systems. Spiral Development teams led by SPAWAR are established with engineering representatives from the three programs and their primary contractors to:<sup>152</sup>

- Outline the basic time critical strike related functions in each system
- Identify the major areas of overlap and gaps

<sup>151</sup> Ibid. p. 3-2.

<sup>152</sup> NFN Virtual Program Office. Draft *White Paper on Naval Fires Network for the Assistant Secretary of the Navy for Research, Development and Acquisition*. 17 October 2002. p. 17.

- Choose “best of breed” or best combination of functionalities
- Develop and cost plans for integrating or converging the systems

In the first year of the JFN VPO effort, the SPAWAR-led engineering teams addressed overlaps in track management, target generation, and tactical reconnaissance imagery capabilities. The JFN Chief Engineer also began discussions and early planning for follow-on integration/convergence issues which address the following issues:<sup>153</sup>

- Positioning and time standards
- Multi-INT correlation and data display
- METOC information ingest
- SIGINT processing
- Merging TES’s ISR workflow manager and JSIPS-N’s targeting workflow manager into a seamless “strikeflow” architecture

This engineering approach being utilized by the JFN program is expected to speed the time critical targeting timelines aboard Naval platforms; decrease equipment, maintenance, manning, training and cost of time critical targeting capability; speed the delivery of new capabilities to the Fleet; and develop new cross-program, cross-SYSCOM, and contractor teaming techniques, that will be required for implementation of the Navy’s FORCENet concept.<sup>154</sup>

In order to support rapid deployment of existing capabilities while continuing to improve the system, a phased “spiral development” and fielding approach has been utilized in the near-term. This spiral approach is illustrated in Figure 25. This spiral approach is eliminating the distinction between TES, GCCS-M, and JSIPS-N and moving towards a converged JFN architecture as shown in Figure 26.

---

<sup>153</sup> Ibid. p. 17.

<sup>154</sup> Ibid. p. 17.

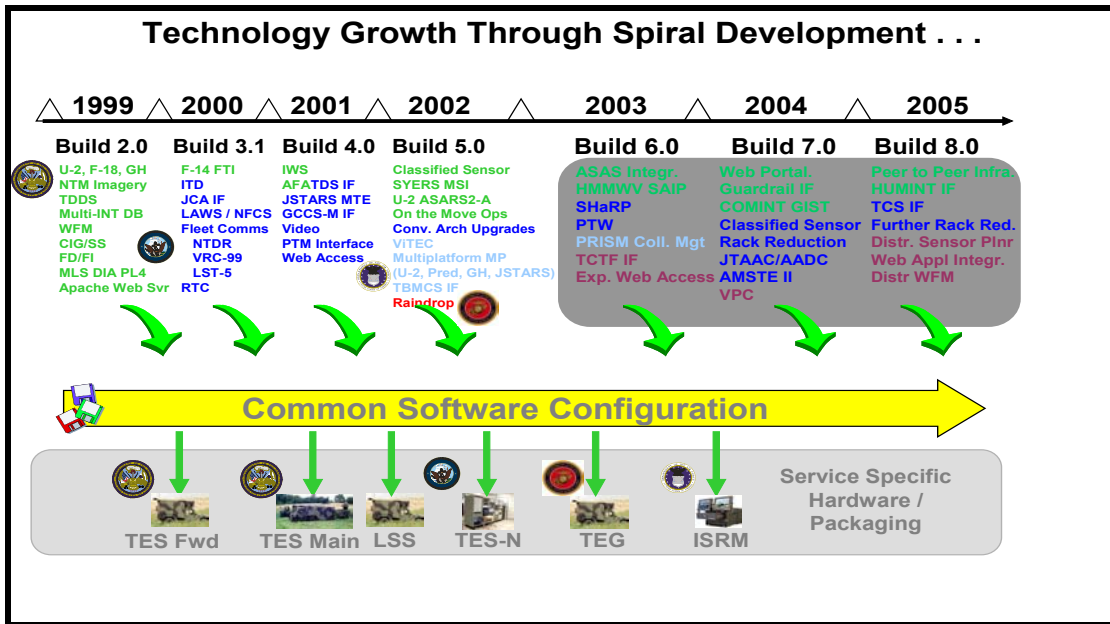

Figure 25. TES/JFN Spiral Development Plan<sup>155</sup>

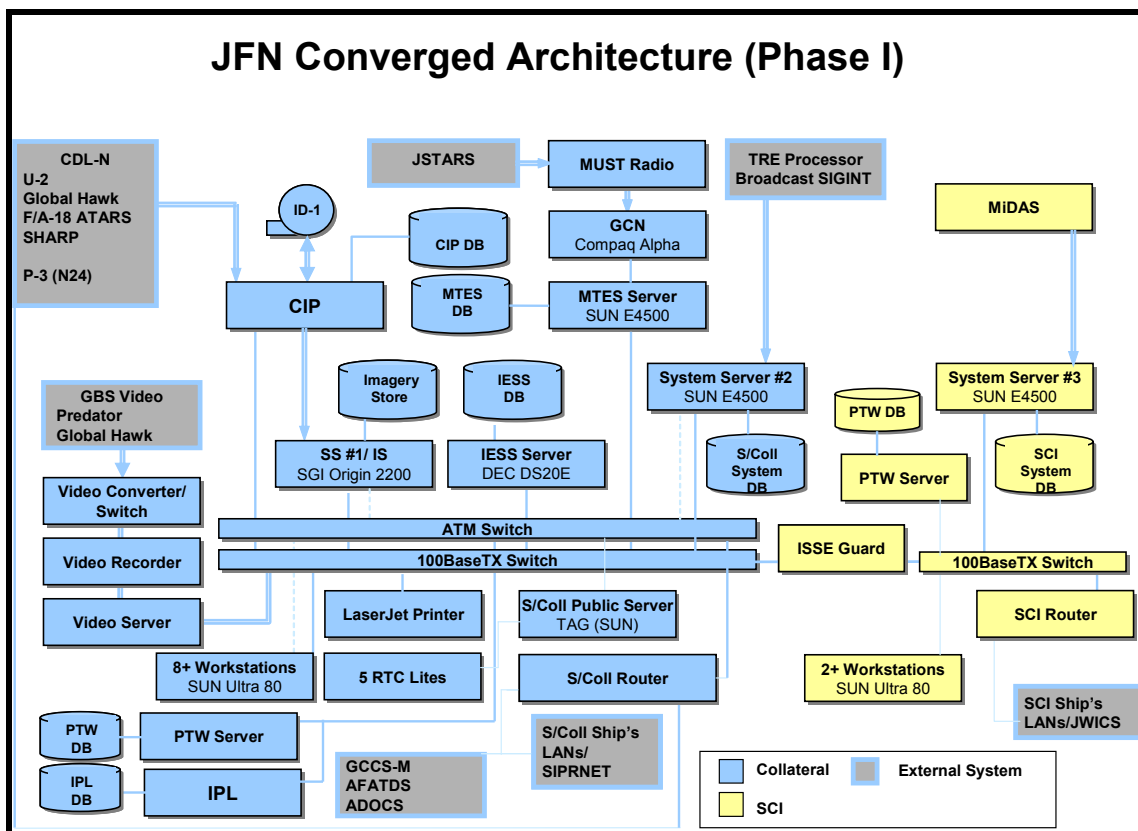

Figure 26. JFN Converged Architecture<sup>156</sup>

<sup>155</sup> E-mail from Ms Destiny Burns. JFN Program Office. 5 June 2003.

<sup>156</sup> Ibid.

## **G. JFN REQUIREMENTS**

### **1. NFN MNS**

Requirements for JFN were first formalized in June 2002 as the Naval Fires Network (NFN) Mission Need Statement (MNS). The MNS addressed the *Integrating Precision Effects* guidance contained in the *Precision Engagement* portion of the *Modernization* section of the Defense Planning Guidance, Update for Fiscal Years 2002-2007 dated April 2000 (pp. 126-127), which stated:<sup>157</sup>

The Department will continue to develop a fused C4ISR architecture and battle management process that supports the optimum application of precision effects, thereby significantly enhancing joint combat effectiveness. The Services, CINCs, and defense agencies will develop future operational capabilities that leverage and integrate emerging operational concepts, advanced information technologies, and enhancements in lethal and nonlethal effects. The CINCs, Services, and defense agencies will continue to develop systems and support demonstration activities that integrate time-critical targeting information and capabilities in an efficient and timely manner. The Services and defense agencies must be prepared to incorporate technology from ACTDs and other relevant efforts. Architectures and processes must be transparent across all components. The goal is to achieve a robust ‘system of systems’ that allows early and continuous combat operations to gain the initiative, eliminate enemy courses of action and, attain operational objectives.

This section of the DPG highlights the importance DoD has placed on integrating the services C4ISR systems and on integrating ISR and engagement.

The overall mission for JFN, as described in the NFN MNS, is to provide the network-centric infrastructure and processing capability necessary to support all forms of strike missions (CVW Strike, Surface Strike, Land Attack, etc).<sup>158</sup>

Currently, the time required to find, fix, and target is estimated at around 80 – 90% of the targeting solution, with only 10 – 20% utilized for engagement. The MNS requires NFN to reverse this split and reduce the time required for finding, fixing, and targeting to 10 – 20% without increasing the overall time required.<sup>159</sup> Obviously, if the time required for finding,

---

<sup>157</sup> Chief of Naval Operations. *Mission Need Statement (MNS) for Naval Fires Network (NFN)*, Ver 3.7. 6 June 2002.

<sup>158</sup> *Ibid.* p. 1.

<sup>159</sup> *Ibid.* p. 3.

fixing, and targeting is reduced significantly, then the chance of affecting a target will increase dramatically. The United States has consistently shown through history that one of the biggest challenges we face on a battlefield is finding and correctly identifying a target. Greater efficiency on the battlefield will be accomplished if we reduce the amount of time to detect and classify a target through quicker and better correlation of existing intelligence data.

The MNS also requires JFN be fully interoperable and spectrum supportable with new and existing systems regardless of Service affiliation. JFN must be capable of accepting data from the current three-tier architecture consisting of the Joint Planning Network (JPN), Joint Data Network (JDN), and Joint Composite Tracking Network (JCTN). JFN must also comply with the Maritime Cryptologic Architecture (MCA) as well as the Joint Technical Architecture (JTA) and Defense Information Infrastructure - Common Operating Environment (DII-COE). JFN must be interoperable with the C4I interfaces of the Area Commanders, each military service, and DoD, as well as other U.S. Government Agencies, and non-government organizations.<sup>160</sup>

## **2. DCGS-N TRD**

As mentioned previously, the Navy is participating in the Air Force's Block 10.2 Multi-INT Core solicitation. A Technical Requirements Document (TRD) for Navy specifications was included as part of the Air Force's Request for Proposals (RFP) and is referred to as DCGS-N TRD. Within the TRD, there are 59 specifications which pertain to Navy ISR needs. There are also another 21 specifications which pertain to separately priced Navy "fires" options.<sup>161</sup>

The following highlights some of the primary ISR specifications identified in the TRD:<sup>162</sup>

- The AF 10.2 Backbone and Multi-INT Management Services design shall be the baseline design for DCGS-N.
- The system shall not employ newly developed items (software, hardware, or protocols) unless it can be demonstrated that a mission critical function cannot be performed adequately or efficiently in its absence.

---

<sup>160</sup> Ibid. p. 4-5.

<sup>161</sup> DCGS-N Technical Requirements Document. DCGS-N TRD No. AFDCGS-N-03-002. 01 May 2003. p. 2.

<sup>162</sup> Ibid. p. 2.



- Newly developed hardware, software, and protocols shall only be used if it can be demonstrated that no existing commercial or government products are available to adequately meet the requirement in an efficient, cost effective manner.
- The system shall be capable of data level interoperability with the Tactical Exploitation System (TES) family of systems.
- The system shall include multi-point voice over IP as well as the ability to share applications to support distributed collaborative imagery exploitation and targeting. The system should also include the collaborative tools associated with the Defense Collaboration Tool Set (DCTS).
- The DCGS-N system will be capable of operating on tactical, national, and theater wide networks to include communication with afloat units. The system will evolve with Navy communications infrastructure.
- Information sources and services within the enterprise shall be linked to the Multi-INT Management Service. Specific sources shall include:
  1. GCCSI3/GCCS-M
  2. MIDB (National/Local)
  3. Imagery Exploitation Support System (IESS) at the Secret level
  4. Imagery Product Library
  5. Naval Mission Planning Systems (TAMPS/JMPS)
  6. Precision Targeting Workstation
- The system shall support both periodic and streaming transfer of mission data from DCGS-N locations in NITF format (compressed and uncompressed) to large-scale storage and archival devices (e.g. WARP, JCA, NIMA Library) with network connectivity
- The system shall support SHARP receipt and processing including multi-segment TRE tags.
- The DCGS system shall interface to the own-ship Global Command and Control System – Maritime (GCCS-M) system via the ship’s IT21 LAN.
- The system shall have the capability to dynamically task, retask and synchronize the collection processing and exploitation of national platforms/sensors.

Although more detailed specifications are spelled out in the TRD, the above list is provided to highlight the applicability of the specifications in the TRD to components within the JFN system.

## H. JFN TODAY

The Assistant Secretary of the Navy for Research, Development, and Acquisition (ASN (RD&A)) stated in a memorandum that on 5 February 2003, the Navy reached internal agreement to converge the existing capabilities of the Tactical Exploitation System – Navy (TES-N), the Joint Service Imagery Processing System – Navy (JSIPS-N), and the Global Command and Control System – Maritime (GCCS-M) into a Naval Fires Network architecture. The architecture will be based on the TES system and modified to meet fleet requirements and known deficiencies. He also identified that on 25 February 2003, an all-service meeting agreed to move forward jointly on a Joint Fires Network capability with the Air Force, Army, and Marine Corps using the Air Force Distributed Common Ground Station version 10.2 competition as the mechanism.<sup>163</sup>

ASN (RD&A) also stated in an e-mail dated 16 February 2003 that the Navy needs to converge on a TES-based ISR system. Regardless of whether it's called DCGS, TES, JFN, etc, the existing TES systems provide a great opportunity to proceed forward jointly. The e-mail highlights the following points:<sup>164</sup>

- The core TES system has been developed over several years and consists of about 1.7 million lines of code.
- The TES core system responds to challenging requirements such as displaying a 2 gigabyte image in less than 5 seconds
- The TES system is already the core of DCGS-A, TES, JFN, TEG, and ISR-M
- The Army, Navy, Marine Corps, and Air Force already have purchased and deployed the basic TES-derived system
- The TES system allows operators access to a full spectrum of multiple intelligence sources, including access to several national and most tactical systems in real time
- The TES system, given the requirement to interface with classified data sources, is basically an open architecture
- Already over 35 service applications - targeting tools, tactical sensor applications, etc. - have been integrated into TES using the application interfaces (API's)

---

<sup>163</sup> Assistant Secretary of the Navy (Research, Development and Acquisition) Memorandum for Distribution, Subject: Joint Fires Network. 17 March 2003.

<sup>164</sup> Assistant Secretary of the Navy (Research, Development and Acquisition). E-mail to Mr Bolton, Dr Sambur, and Mr Wynne. 16 February 2003.

- The TES architecture appears to be extensible to accommodate further growth and addition of application
- The TES package has a disciplined software block release process. All users get all core software and integrated applications, and the user only has to activate the license to use the included applications
- A Joint Configuration Control Board, which includes membership from each of the services, approves the addition of applications to the TES backbone
- These additions have been completed in as little as a week and at costs ranging from a few hundred \$K to about \$8 M
- The TES system offers a range of options from a limited functionality web-based Remote Terminal Capability Lite (RTC-Lite) to an RTC (~\$2M) to a TES/TES-N/TEG/ISR-M system (~\$15M)

In his 16 February 2003 e-mail, ASN(RD&A) also highlighted that the services have enormous potential within the TES system to eliminate some national and tactical stovepipes in the intelligence systems. He considers it possible to make the details of the TES core available to other contractors to eliminate Northrop Grumman (TES Manufacturer) from having an unfair advantage and make it possible to break down any existing barriers to interoperability within ISR systems.<sup>165</sup>

## **I. CHAPTER SUMMARY**

JFN is comprised on several systems that provide an outstanding capability for naval units. GCCS-M provides naval commanders a timely Common Operational Picture (COP) containing geo-locational track information on friendly, hostile, and neutral land, sea, and air forces integrated with intelligence, imagery, and environmental information. JSIPS-N provides the capability to receive imagery from national and tactical sources in a variety of formats and to create precise and accurate imagery information products which are tactically and operationally significant. JSIPS-N also provides imagery exploitation and targeting for PGMs in support of tactical aircraft strike and imagery exploitation and target folder services support for TLAM strike planning.

TES-N is an integrated, scalable, multi-intelligence system specifically designed for rapid correlation of national and theater ISR information to support network centric operations. TES-

---

<sup>165</sup> Ibid.

N provides the warfighting commander with access to near-real time, multi-source, and continuously updated day/night battlespace ISR information. TES-N is interoperable with other service derivatives of the TES system: the Army's TES (TES-A), the Marine Corp's Tactical Exploitation Group (TEG) and the Air Force's ISR Manager (ISR-M).

JFN supports the targeting cycle in the planning & direction, find & track, fix & target steps. The engagement step is not yet a function represented by the components of JFN, however this issue is being addressed by the program office.

The TES-N Integrated Tactical Display (ITD) provides a single integrated display of Cross-INT data, U2 navigation and collection plans, image wire frames, and map wire frames overlaid upon imagery and maps.

TES-N uses a common software application baseline to interface with other service TES-based systems. This commonality enables the naval commander to share real-time battlespace awareness rapidly and seamlessly with other services and to participate fully in Joint collaborative prosecution of time critical targets.

ASN(RD&A) has indicated significant support for JFN. He has expressed an understanding that the capabilities now provided by JFN must be capitalized on for the near-term and continued to be improved in the future to provided even better integration with other services in the long run.

THIS PAGE INTENTIONALLY LEFT BLANK

## V. SUMMARY/CONCLUSIONS

### A. SUMMARY

The Department of Defense (DoD) has provided guidance to the services on what will be required of ISR systems of the future. The Distributed Common Ground/Surface System (DCGS) represents DoD's strategy for how to achieve fully interoperable ISR systems as well as an architecture of how it will look. DCGS creates an umbrella program which covers all processing, exploitation, and dissemination capabilities required for the foreseeable future.

In order to make this vision happen, DoD put in place the DCGS Oversight Council with related working group level IPTs. The council is responsible for guiding the implementation of a multi-intelligence, multi-platform, tasking, processing, exploitation, and dissemination (TPED) architecture for DoD's ISR collection systems. The vision and operational concept for DCGS is codified in the ISR Integrated Capstone Requirements Strategic Plan (ISR-ICSP). The plan provides an integration roadmap intended to guide long-range planning and program procurement.

Within the DCGS structure, the Navy is represented solely by OPNAV N20 since they are the Navy's lead for ISR. However, JFN is envisioned to be both an ISR management system and a fires engagement system. Also OPNAV N61 has taken over Resource Sponsorship for all of the component systems which make up JFN. Therefore, N61 will have to work hard to ensure its requirements for JFN to be an engagement enabler as well as an ISR manager are clearly articulated through requirements documents and representation within the DCGS Council. Since N61 is not directly involved in the Navy's representation on the council, they will have to work hard to build support within N20 to ensure that JFN priorities and concerns are included in the priorities and concerns which N20 advances within the DCGS Council and its Integrated Product Teams.

It is obvious that in the future, DoD's ISR capabilities will need to operate within a larger information grid that ties local, theater and national assets together in one seamless network. Commander's don't care how they get the information they need to make decisions, they just want it there when needed.

The ISR-ICSP identifies ISR architecture needs of the future which include “dynamic control of theater sensors and platforms; real-time visualization of ISR battlespace information; decision aids supporting ISR information; and collaborative command and control features.” In order to obtain these capabilities, DoD’s ISR Vision 21 requires ISR community integration with the Global Information Grid (GIG); cross-domain integration to eliminate ISR system stovepipes; integration of all available ISR information with a common operational picture (COP); integration of ISR with real-time operations; and multi-INT collaboration which provides near real-time TPED to national, theater, and tactical levels.

As mentioned in the ISR-ICSP, the future ISR environment will be an open but secure system which resides on both DoD and Government intelligence networks embedded within a global grid that supports both Defense and commercial interests. The intelligence community will need to structure itself to become information providers to this global grid and not the stovepiped intelligence communities which existed in the past.

The DoD DCGS CRD identified a core set of platforms and sensors which it referred to as the Baseline (e.g.: U-2, Global Hawk, EP-3, etc). Although JFN can receive information from these sensors through its multiple components, continuing to converge the JFN architecture and improving its capabilities will reduce the time required for JFN to process this information and better enable it to support time critical targeting.

The DoD DCGS CRD also requires each service to utilize DII-COE standards “to the maximum extent possible.” Many of the components of JFN were developed being DII-COE compliant however, as the architecture is converged, this trend will need to continue. DII-COE provides some interoperability however, it doesn’t cover all cases and as stovepiped systems are converged, new standards will emerge.

The future of ISR is going to challenge our intelligence systems in ways never before considered: allowing one service to control another service’s sensor/platform; posting information to a global information grid before it has been processed; making information available before a decision maker knows he/she needs it. These concepts, which in the past would never have been considered because of procedure or system limitations, will surely guide our ISR systems of the future.

The Air Force's Block 10.2 Multi-INT Core solicitation provides an excellent opportunity for all services to develop truly interoperable ISR systems. The services capitalized on the opportunity to help shape the Backbone so it supports the requirements of all services. However, only the Navy chose to go along with the Air Force now in the solicitation. Each service needs to remain connected with this effort and move quickly to ensure their systems meet the Backbone requirements.

The Air Force, Army and the Marine Corps are in the process of spiral developing their existing TES capability into other systems: the Air Force in the form of its Block 10.2 Multi-INT Core, the Army in its DCGS-A; and the Marine Corps in its TEG system. As the Air Force and the Navy proceed along the path of the Block 10.2 Multi-INT Core, it would be very easy for the Army and the Marine Corps to continue to develop systems which are not interoperable with the Air Force and the Navy's systems. Coordination among the services must continue if the vision of DoDs DCGS is to be realized.

At the end of Chapter II, I provided a table (reproduced below as Table 10) which I felt summarized the capabilities required of a DCGS system. As the Navy's near-term DCGS system, I feel that JFN meets these requirements. However, in the long run, more will need to be accomplished with the system to improve its capabilities, reduce processing time, and ensure interoperability with the constantly changing group of systems which will comprise DoD DCGS.

The TES-N Integrated Tactical Display provides a great capability to display information from multiple intelligence sources on top of an operational picture. However, to truly provide the necessary functionality in the future, the ability to fuse this information together into one track which can be shared with other users will contribute to JFNs ability to rapidly process and correlate ISR information and produce a better situational awareness.



- 
- Ability to share ISR information with other service's ISR systems
  - Real-time visualization of ISR battlespace information
  - Comprehensive, accurate, clear, and coherent picture of the battlespace which includes "blue" (friendly), "red" (enemy), and "white" (neutral) forces
  - Collaborative command and control features
  - Minimization of unnecessary data sent over the network
  - DII-COE registered COTS/GOTS equipment utilized as much as possible
  - Planning tools which predict information requirements and react to specific requests
  - Enable dynamic retasking of sensors
  - Allow for multiple sensor cross-cueing and synchronization of ISR assets with operations
  - Access to finished Intelligence Preparation of the Battlespace (IPB) products
  - Access to TTP summaries, basic platform/sensor performance, and usage guidance for U.S., allied, and coalition ISR platforms and sensors
- 

**Table 10. DCGS Capabilities Summary**

Through my research, it appeared to me that within the Department of the Navy, there are two "camps" regarding JFN. One "camp" does not support the program and would like to see it vanish completely and the other "camp" defends it without question. From the sidelines, it appears that the capability provided by JFN is remarkable. JFN provides the near-term solution for interoperability within the Navy and to a limited extent, with the other services. Greater cooperation is required between the opponents and the supporters of JFN. JFN provides the initial phase of capabilities discussed in the ISR-ICSP and the DoD DCGS CRD.

## **B. CONCLUSIONS**

My primary research question was that given DoD's view of an overarching Distributed Common Ground/Surface System (DCGS) architecture and the ISR systems of each of the services, would JFN be able to properly share and exploit all ISR information available within a Joint Force architecture in order to support time critical targeting? From my research, I feel that JFN will be able to fill this requirement if it continues to evolve along with the evolving DoD DCGS system. JFN has proven a certain level of interoperability with the other services, before

the converged architecture. As the JFN system continues to evolve, its interoperability with the other services and its contribution to time critical targeting will continue to improve.

My second research question was to identify any additional capabilities which must be stated in the requirements for JFN to ensure its ability to rapidly prosecute time critical targets. From my research, it's obvious that the need for faster, better information is only going to increase in the future. Concepts like smart push/smart pull, automatic correlation of multi-INT data into a single track, and enhanced collaborative command & control features, among others, will need to be incorporated in to future spirals of JFN. Also, the engagement capability which is currently being addressed by the JFN Program Office, will contribute significantly to reducing the time required for conducting time critical strike.

THIS PAGE INTENTIONALLY LEFT BLANK

## ACRONYMS

<b>ACTD</b>	Advanced Concept Technology Demonstration
<b>AFATDS</b>	Advanced Field Artillery Tactical Data System
<b>AF DCGS</b>	Air Force Distributed Common Ground/Surface System
<b>AOC</b>	Air Operations Center
<b>AOR</b>	Area of Responsibility
<b>APS</b>	Afloat Planning System
<b>ASAS</b>	All Source Analysis System
<b>ASD (C3I)</b>	Assistant Secretary of Defense for Command, Control, and Communications
<b>ASN(RD&amp;A)</b>	Assistant Secretary of the Navy for Research, Development, and Acquisition
<b>ASPO</b>	Army Space Programs Office
<b>ATO</b>	Air Tasking Order
<b>ATWCS</b>	Advanced Tomahawk Weapon Control System
<b>C<sup>2</sup></b>	Command and Control
<b>C3I</b>	Command, Control, and Communications
<b>C4I</b>	Command, Control, Communications, Computers and Intelligence
<b>C4ISR</b>	Command, Control, Communications, Computers, Intelligence, Surveillance, and Reconnaissance
<b>CDL</b>	Common Data Link
<b>CGS</b>	Common Ground Station
<b>CI/HUMINT</b>	Counter Intelligence/ Human Intelligence
<b>CONUS</b>	Continental United States
<b>COP</b>	Common Operational Picture
<b>COTS</b>	Commercial Off The Shelf
<b>CRD</b>	Capstone Requirements Document
<b>CROFA</b>	Consolidated Regional Operations Facility Airborne
<b>DASD</b>	Deputy, Assistant Secretary of Defense
<b>DB</b>	Database
<b>DCGS</b>	Distributed Common Ground/Surface System
<b>DCGS-A</b>	Distributed Common Ground/Surface System – Army
<b>DCGS-MC</b>	Distributed Common Ground/Surface System – Marine Corps
<b>DCGS-N</b>	Distributed Common Ground/Surface System – Navy
<b>DERF</b>	Defense Emergency Response Funding
<b>DII-COE</b>	Defense Information Infrastructure-Common Operating Environment
<b>DISA</b>	Defense Information Systems Agency
<b>DMPI</b>	Desired Mean Point of Impact
<b>DoD</b>	Department of Defense
<b>DOTMLPF</b>	Doctrine, Organization, Training, Materiel, Leadership, and Education
<b>DPA</b>	DCGS PEDS Architecture
<b>EMW</b>	Expeditionary Maneuver Warfare
<b>F2T2EA</b>	Find, Fix, Track, Target, Engage, Assess
<b>FBE</b>	Fleet Battle Experiment
<b>FoS</b>	Family of systems
<b>FTI</b>	Fixed Target Indicator

<b>GAO</b>	General Accounting Office
<b>GCCS-I3</b>	Global Command and Control System - Integrated Imagery and Intelligence
<b>GCCS-M</b>	Global Command and Control System – Maritime
<b>GIG</b>	Global Information Grid
<b>GOTS</b>	Government Off The Shelf
<b>GMTI</b>	Ground Moving Target Indicator
<b>GSD</b>	Graphical Situation Display
<b>HUMINT</b>	Human Intelligence
<b>IAS</b>	Intelligence Analysis System
<b>IESS</b>	Imagery Exploitation Support System
<b>IIR</b>	Imagery Interpretation Reports
<b>IMINT</b>	Imagery Intelligence
<b>INT</b>	Intelligence
<b>IO</b>	Information Operations
<b>IP</b>	Internet Protocol
<b>IPB</b>	Intelligence Preparation of the Battlespace
<b>IPL</b>	Image Products Library
<b>IPT</b>	Integrated Product Team
<b>ISR</b>	Intelligence, Surveillance, and Reconnaissance
<b>ISR-ICSP</b>	Intelligence, Surveillance, and Reconnaissance Integrated Capstone Strategic Plan
<b>ISR-M</b>	Intelligence, Surveillance, and Reconnaissance Manager
<b>ITD</b>	Integrated Tactical Display
<b>JCA</b>	JSIPS-N Concentration Architecture
<b>JDISS</b>	Joint Deployable Intelligence Support System
<b>JFACC</b>	Joint Force Air Component Commander
<b>JFC</b>	Joint Force Commander
<b>JFN</b>	Joint Fires Network
<b>JIC</b>	Joint Intelligence Center
<b>JISR</b>	Joint Intelligence, Surveillance, and Reconnaissance
<b>JITC</b>	Joint Interoperability Test Command
<b>JOA</b>	Joint Operational Architecture
<b>JOC</b>	Joint Operational Capability
<b>JROC</b>	Joint Requirements Oversight Council
<b>JSIPS-N</b>	Joint Service Imagery Processing System – Navy
<b>JSTARS</b>	Joint Surveillance Target Attack Radar System
<b>JTA</b>	Joint Technical Architecture
<b>JTF</b>	Joint Task Force
<b>JTT</b>	Joint Targeting Toolbox
<b>JTTP</b>	Joint Tactics, Techniques, and Procedures
<b>JWCA</b>	Joint Warfighter Capability Analysis
<b>LAN</b>	Local Area Network
<b>LSS</b>	Littoral Surveillance System
<b>MAGIS</b>	Marine Air Ground Intelligence System
<b>MAGTF</b>	Marine Air-Ground Task Forces
<b>MASINT</b>	Measurement and Signature Intelligence
<b>MEDAL</b>	MIW [Mine Warfare] and Environmental Decision Aids Library

<b>MEF</b>	Marine Expeditionary Force
<b>MEU</b>	Marine Expeditionary Unit
<b>MIW</b>	Mine Warfare
<b>MIDB</b>	Modernized Integrated Data Base
<b>MIUW</b>	Mobile Inshore Undersea Warfare
<b>MNS</b>	Mission Need Statement
<b>MTES</b>	Moving Target Exploitation System
<b>MTI</b>	Moving Target Indicator
<b>NAVAIR</b>	Naval Air Systems Command
<b>NAVSEA</b>	Naval Sea Systems Command
<b>NDI</b>	Non-Developmental Item
<b>NES</b>	National Exploitation System
<b>NFN</b>	Naval Fires Network
<b>NITF</b>	National Imagery Transmission Format
<b>NJI</b>	Naval JSTARS Interface
<b>NMS</b>	National Military Strategy
<b>NSS</b>	National Security Strategy
<b>NTCS-A</b>	Navy Tactical Command System - Afloat
<b>NTM</b>	National Technical Means
<b>OASD</b>	Office of the Assistant Secretary of Defense
<b>OPNAV</b>	Chief of Naval Operations
<b>ORD</b>	Operational Requirements Document
<b>OSINT</b>	Open-Source Intelligence
<b>PEDS</b>	Processing, Exploitation, and Dissemination System
<b>PEO</b>	Program Executive Officer
<b>PGM</b>	Precision Guided Munitions
<b>PIR</b>	Priority Intelligence Requirements
<b>PTW</b>	Precision Targeting Workstation
<b>RFP</b>	Request for Proposals
<b>RMS</b>	Requirements Management System
<b>ROE</b>	Rules of Engagement
<b>RTC</b>	Remote Terminal Component
<b>RTC-Lite</b>	Remote Terminal Component – Lite
<b>SAR</b>	Synthetic Aperture Radar
<b>SECNAV</b>	Secretary of the Navy
<b>SHARP</b>	Shared Airborne Reconnaissance Pod
<b>SIGINT</b>	Signals Intelligence
<b>SJFHQ</b>	Standing Joint Force Headquarters
<b>SPAWAR</b>	Space and Naval Warfare Systems Command
<b>S-TRED</b>	Standard Tactical Receive Equipment Display
<b>SYSCOM</b>	Systems Command
<b>TADIL</b>	Tactical Digital Information Link
<b>TAMPS</b>	Tactical Aircraft Mission Planning System
<b>TARS</b>	Tactical Airborne Reconnaissance System
<b>TARTS</b>	Tactical Real-Time Targeting System
<b>TBMCS</b>	Theater Battle Management Core System

<b>TCAC</b>	Technical Control and Analysis Center
<b>TCPED</b>	Tasking, Collection, Processing, Exploitation and Dissemination
<b>TCS</b>	Time Critical Strike
<b>TCT</b>	Time Critical Target
<b>TDBM</b>	Track Database Manager
<b>TDDS</b>	Tactical Related Applications (TRAP) Data Dissemination System
<b>TEG</b>	Tactical Exploitation Group
<b>TEL</b>	Transportable erector-launchers
<b>TENCAP</b>	Tactical Exploitation of National Capabilities
<b>TES</b>	Tactical Exploitation System
<b>TES-N</b>	Tactical Exploitation System – Navy
<b>TFRD</b>	Transmission Format Requirements Document
<b>TIBS</b>	Tactical Information Broadcast System
<b>TIS</b>	Tactical Input Segment
<b>TLAM</b>	Tomahawk Land Attack Missile
<b>TPED</b>	Tasking, Processing, Exploitation and Dissemination
<b>TPPU</b>	Task, Post, Process, and Use
<b>TRAP</b>	Tactical Related Applications
<b>TRD</b>	Technical Requirements Document
<b>TRE</b>	Tactical Receive Equipment
<b>TRIXS</b>	Tactical Reconnaissance Intelligence Exchange System
<b>TRSS</b>	Tactical Remote Sensor System
<b>TST</b>	Time Sensitive Targeting
<b>TTP</b>	Tactics, Techniques, and Procedures
<b>TTWCS</b>	Tactical Tomahawk Weapon Control System
<b>UAV</b>	Unmanned Aerial Vehicle
<b>USAF</b>	United States Air Force
<b>USJFCOM</b>	United States Joint Forces Command
<b>VPO</b>	Virtual Program Office

## INITIAL DISTRIBUTION LIST

1. Defense Technical Information Center  
Ft. Belvoir, Virginia
2. Dudley Knox Library  
Naval Postgraduate School  
Monterey, California
3. Prof. William Kemple  
Naval Postgraduate School  
Monterey, CA
4. Prof. John S. Osmundson  
Naval Postgraduate School  
Monterey, CA
5. Prof. Dan C. Boger  
Naval Postgraduate School  
Monterey, CA
6. Ms. Destiny Burns  
JFN Program Office  
Chantilly, VA
7. Mr. Cecil Beard  
Headquarters, Marine Corps  
Arlington, VA
8. Mr. Thom Revay  
Army Space Programs Office  
Alexandria, VA
9. LTC Lawrence Turner  
Office of the Secretary of Defense (C3I)  
Arlington, VA
10. Maj Harry Sears, USAF  
Chief of Naval Operations (N20)  
Arlington, VA