

A  
19

MUNICIPAL ENGINEERING

IN BENGAL.

M16374

THE ROYAL SOCIETY  
for the Promotion  
OF HEALTH  
LIBRARY

*Farmersky*  
↓



*A/19*

*Presented by  
A. E. S. Mr. M. Inst. C. E.*

*August 1899.*



22101817414



# THE ROYAL SOCIETY OF HEALTH

Founded 1876

## LIBRARY REGULATIONS

(a) Books, periodicals and pamphlets may be borrowed by Fellows, Ordinary Members, Associates and Affiliates personally or by a messenger producing a written order. The person to whom such publications are delivered shall sign a receipt for them in a book provided for that purpose.

(b) Publications may be borrowed through the post, or by other means of carriage, upon a written order. The postage or carriage of publications returned to the Society shall be defrayed by the borrower.

(c) A borrower may not have more than three publications in his possession at one time.

(d) A borrower will be considered liable for the value of any publication lost or damaged while on loan to him, and, if it be a single volume or part of a set, for the value of the whole work thereby rendered imperfect. Marking or writing in the publications is not permitted, and borrowers are requested to call attention to damage of this character.

(e) Books and pamphlets may be retained for twenty-eight days. Periodicals may be retained for fourteen days. Applications for extension of the loan period must be made in writing before its expiry. No publication may be kept longer than three months.

(f) Books and pamphlets added to the library will not be lent until after the expiry of one month from the date received. The current number of a periodical may not be borrowed.

(g) Borrowers retaining publications longer than the time specified, and neglecting to return them when demanded, forfeit the right to borrow until they be returned, and for such further time as may be ordered by the Council.

Any borrower failing to comply with a request for the return of a publication shall be considered liable for the cost of replacing it, and the Council may, after giving due notice to him, order it to be replaced at his expense.

No publication may be reissued to the same borrower until at least seven days have elapsed after its return, neither may it be transferred by one borrower to another.

(h) Publications may not be taken or sent out of the United Kingdom.

(i) Publications returned through the post must be securely packed in a box or otherwise adequately protected.

(j) The Library may be used for reference by Fellows, Ordinary Members, Associates and Affiliates during the office hours of the Society.

(k) Parcels should be addressed:

THE ROYAL SOCIETY OF HEALTH  
90 BUCKINGHAM PALACE ROAD, LONDON, S.W.1

*Presented to the Sanitary Institute  
with the Author's Compliments  
22<sup>nd</sup> June 1889*

# MUNICIPAL ENGINEERING

APPLICABLE TO

CONDITIONS EXISTING IN BENGAL.

---

SIX LECTURES

DELIVERED IN

February and March 1899

AT THE

CIVIL ENGINEERING COLLEGE, SIBPUR,

BY

A. E. SILK,

MEMBER OF THE INSTITUTE OF CIVIL ENGINEERS,  
MEMBER OF THE SANITARY INSTITUTE,  
SANITARY ENGINEER, BENGAL.



CALCUTTA:

BENGAL SECRETARIAT PRESS.

1899.

*Price Rs. 3 annas 4.*

Published at the BENGAL SECRETARIAT BOOK DEPÔT,  
Writers' Buildings, Calcutta.

OFFICIAL AGENTS.

*In India—*

THACKER, SPINK & Co., Calcutta.  
W. NEWMAN & Co., Calcutta.  
THACKER & Co., Bombay.  
HIGGINBOTHAM & Co., Madras.  
SUPERINTENDENT, AMERICAN BAPTIST MISSION PRESS, Rangoon.

*In London—*

E. A. ARNOLD, 37 Bedford Street, Strand, W.C.  
CONSTABLE & Co., 2 Whitehall Gardens, S.W.  
SAMPSON LOW, MARSTON & Co., St. Dunstan's House, Fetter Lane, E.C.  
P. S. KING & SON, 9 Bridge Street, Westminster, S.W.  
LUZAC & Co., 46 Great Russell Street, W.C.  
KEGAN PAUL, TRENCH, TRÜBNER & Co., Charing Cross Road, W.C.  
B. QUARITCH, 15 Piccadilly, W.

*On the Continent—*

FRIEDLÄNDER & SOHN, 11 Carlstrasse, Berlin.  
OTTO HARRASSOWITZ, Leipzig.  
KARL W. HIERSEMANN, Leipzig.  
ERNEST LEROUX, 28 Rue Bonaparte, Paris.  
MARTINUS NIJHOFF, The Hague.

M16374

WELLCOME INSTITUTE LIBRARY	
Coll.	welMOMec
Call	
No.	WA 671
	1899
	558 m

## TABLE OF CONTENTS.

---

	PAGE.
Introduction . . . . .	1
Water-supply—	
The sources of water . . . . .	5
The quality of water . . . . .	13
The quantity of water . . . . .	16
The collection of water . . . . .	33
The purification of water . . . . .	45
The raising of water . . . . .	66
The distribution of water . . . . .	77
General specifications for water-works . . . . .	87
Drainage . . . . .	93
Conservancy . . . . .	103
Roads . . . . .	112





# LECTURES

ON

## MUNICIPAL ENGINEERING

APPLICABLE TO

### CONDITIONS EXISTING IN BENGAL.

---

GENTLEMEN,

IN this series of special lectures which the Government of Bengal has honoured me in asking to deliver, I propose to deal, as far as time will permit, with some of the subjects that are included in Municipal accounts under the head of Public Health and Convenience, namely—

- (1) Water-supply,
- (2) Drainage,
- (3) Conservancy,
- (4) Roads,

because, during my tours in the last five years amongst the Municipalities of Bengal, I have found that the Engineers and Overseers, who are more often than not former students of this College, have received but little detailed instruction in these most necessary subjects; and any information that I may now lay before you will, I trust, be found useful, not only by those who leave this College to enter the service of Municipal Commissioners, but by all of you, whether you become Railway Engineers or are engaged in irrigation or road-making, or in any other walks of life, because, after all is said and done, no man can do good and useful work unless he enjoys good health. By being able to design and carry out small works under the first three heads that I have mentioned, each one of you will confer inestimable benefits upon the people amongst whom your lot is cast; you will help them to the enjoyment of better health and thus enable them, not only to ward off attacks of disease, but, what is so important, you will be the indirect cause of their being able to earn larger incomes, and thus live in greater comfort. It is an accepted axiom amongst political economists that the better the health of a community, the greater is the wage-earning capacity.

When I was a student at the Royal Indian Engineering College, Cooper's Hill, I must admit that the subjects that I have mentioned above were given but passing attention and the instruction provided was of the most superficial character, for the reason, first of all, that the

Dr. Simpson, the late Health Officer of Calcutta, informed me that this was having a very material effect on the fever death-rate of that notoriously sickly suburban area; it remains to be seen whether the system of sewers which the Corporation of Calcutta are now constructing in that quarter will have a still further beneficial effect; personally I have very little doubt that it will. I have therefore given drainage the second place on the little list of subjects with which I propose to deal in these lectures. Now as regards the third item, Conservancy: in rural areas and small villages the *excreta* of the population are voided on the open fields surrounding the areas and villages, and are disposed of in a perfectly natural and innocuous manner; but in areas and towns which a good and pure water-supply and efficient drainage have rendered attractive as places of residence or trade, this system is not possible, and so we have to arrange for the removal of the waste matters of the inhabitants as soon as possible after they are produced, and we have to devise means for their destruction or conversion into innocuous forms. We can now picture to ourselves a town in which the water-supply is wholesome, the drainage good and the conservancy arrangements efficient, but you will at once see that although we have made all these arrangements for the welfare of the inhabitants our model town is not likely to prove attractive as a place of residence or as a business centre unless there are roads which are kept in a good state of repair, and these form the subject of the fourth item on my list.

It must not be supposed that the four subjects that I have given above constitute the whole work of a municipal engineer; they are the four most important subjects, and did time permit, I should have some remarks to make on the other subjects included in Municipal accounts under the head of Public Health and Convenience, namely:—

- (a) Hospitals and dispensaries.
- (b) Markets and slaughter-houses.
- (c) Pounds.
- (d) Dak bungalows and *serais*.
- (e) Arboriculture.

But you will find all these subjects very fully dealt with in that excellent Manual by Mr. J. A. Jones, the Sanitary Engineer to the Madras Government, on Hygiene, Sanitation and Sanitary Engineering with special reference to Indian conditions. As far as I know, it is the only work of its kind that has been published within recent years; and although it has been written rather with reference to the conditions that prevail in the Madras Presidency, still there is much information in it which is applicable to other parts of India. You should also study very carefully the lectures on Hygiene which Major H. J. Dyson, I.M.S., F.R.C.S., delivered at this College last year.

And now having pointed out to you how really useful a knowledge of sanitary and municipal engineering can be to all classes of engineers, and what benefits can be conferred on the community at large by putting this knowledge into practice on every possible occasion, I will now proceed to take up the different branches of these lectures in the order that I have already given.

## WATER-SUPPLY.

## THE SOURCES OF WATER.

The rainfall is the source of all water-supplies, but it is not called rain-water in connection with water-supply unless it is collected from roofs or other artificially-prepared surfaces. The rain which falls upon rocky mountains that are either bare or have but scant vegetation when collected is called "upland surface water;" that which runs off fields and cultivated lands is called "surface water from cultivated ground;" that which soaks through the surface soil into a pervious subsoil is known as "subsoil water;" whilst that which travels through a pervious stratum which underlies an impervious stratum, so that it can only be reached by boring through the latter, is called "subterranean or deep-well water." Where an impervious stratum comes to the surface and throws out the subsoil water from the pervious stratum above it, a "land spring" is formed, whilst subterranean water thrown to the surface in any way forms a "deep spring." The water in streams may be derived from any one or more of these sources; but river water is usually a mixture of all. Speaking generally, deep springs yield the purest waters and rivers the most impure unless they are of large volume such as we get in this country. The different classes of water that I have mentioned may generally be arranged in order of purity as follows:—

- (1) Deep-spring water.
- (2) Subterranean or deep-well water.
- (3) Upland surface water.
- (4) Subsoil water (if distant from any collection of houses).
- (5) Land springs.
- (6) River water.
- (7) Surface water from cultivated ground.
- (8) Subsoil water under villages and towns.

In England the above order has to be slightly altered, and river water is put after surface water from cultivated ground, the reason of this being that the rivers in this country are enormously large compared to those in England, and consequently they are more easily capable of purifying any sewage that may be discharged into them, and, further, the quantities of sewage and waste matters per mile of course that are discharged into Indian rivers are comparatively trifling to what they are in England.

As far as possible I have adhered to the classification of waters that obtains in England, because, should you care to pursue the study of water-supplies further, you will have to consult the text-books published in England, and if I explain this classification as far as I can with reference to waters in India, you will more readily understand the subject.

You are of course aware that rainfall is the result of evaporation by the heat of the sun from that portion of the earth that is covered with water, which amounts to something like 145,000,000 square miles. It is not a quantity that will probably enter into your calculations,

but incidentally I would mention that it is estimated that 186,240 cubic miles of water are annually raised from the surface of the globe in the form of vapour, chiefly from the tropical seas. The evaporation over the surface of the ocean is so great that were it not restored, it would depress its level about 5 feet annually. Another estimate is that "about 7,000 lbs. weight of water are evaporated every minute, on an average throughout the year from each square mile of ocean." These are large quantities, and it might naturally be supposed that there should be ample water for everybody in all parts of the world, but we only have to open a book on meteorology to find that there are many thousands of square miles on the face of the earth in which water is practically unknown; in this country we have all heard of the "Sands of Scinde," a tract where the rainfall is practically *nil*. Then at Aden, which is on the sea-coast, rainfall is an event that only occurs once in four or five years; and then no doubt you have heard of the great waterless plains of Australia, in attempting to cross which so many travellers have simply died of thirst. The great desert of Sahara in Africa and the rainless region in the United States of America are other examples of the unequal distribution of rainfall over the globe. But the reasons for this do not come within the scope of these lectures; we have only got to deal with the quality and quantity of water as we find it in the situations I have mentioned.

*Deep-spring water* I have defined as subterranean water thrown to the surface in any way, whereas a "land spring" is the subsoil water that is thrown out of the ground at points where an impervious stratum comes to the surface. You will naturally ask how is subterranean water to be distinguished from subsoil water, and my answer is that unless you know the geological structure of the country and can ascertain the probable course of the water from its collecting ground on which it fell as rain, you must depend on the temperature of the issuing water, for the temperature of the earth increases on an average  $1^{\circ}$  F. for every 60 feet below the surface. At great depths water probably meets with carbonic acid gas under pressure, which it absorbs, and this combined with the elevated temperature increases greatly the solvent powers of the water which possibly explains the greater richness of these springs in mineral constituents. The only deep springs in these provinces with which I am personally acquainted are the celebrated Sitakund springs near Monghyr; here the water comes bubbling up through the rocky bottom of the tank and is so hot that it is only just bearable to the hand. During a visit I paid in October 1897 I took the opportunity of roughly gauging the overflow from the tank, and found that it amounted to 14,000 gallons per hour, or 0.61 cubic foot per second. The water from this and neighbouring springs has the reputation of great purity and wholesomeness, and in old days it was carried down the Ganges in boats for the supply of shipping in the Hooghly; and for many years past it has been used by Messrs. Kellner & Co. for the manufacture of soda water. I find from Hunter's Gazetteer that there are numerous other springs of this sort to be found practically all over India—in Karachi on the west, in Burma on the east, and in Kashmir in the north, while nearer at home they are to be found in the Patna, Singbhum and Birbhum districts and the Sonthal Parganas.

The next in the list is "*subterranean or deep-well water.*" Here, again, a knowledge of the geological structure of the country is really necessary to determine whether a certain well is a "deep" or "shallow" one. The term "deep" in reference to wells is somewhat ambiguous, since different writers attribute to it different meanings. By some, any well over 50 feet in depth is called "deep" whatever the character of the stratum in which it is sunk or the strata through which it passes. By others, the term is used without any reference to actual depth, but to imply that the well is sunk through some impervious stratum into a water-bearing formation lying beneath. But we need not trouble about the definition that may be given to this class of wells in other countries because there can be no such thing as a deep well in the alluvial plains that form the greater portion of these provinces. Land that has been built up from the wash-down of rivers like the Ganges, the Brahmaputra, or the Mahanadi, is of such a heterogeneous character that a true deep well is an impossibility; there is absolutely no uniformity about these deposits, for you may make a boring 50 or 60 feet deep in one spot and never come across a drop of water, whereas if you make a second boring a hundred feet or so away you will come across water a few feet below the surface and in comparatively large quantities; this has been proved time after time in sinking what are known as tube wells, which I shall describe later on.

In the valleys of the Himalayas or the hills of Chota Nagpur and Assam it is possible that true deep wells might be constructed, but there again they would rather partake of the nature of Artesian wells. Some writers state that deep wells passing through impervious into pervious and water-bearing strata are best designated as Artesian, but, on the other hand, this name is generally reserved for those deep wells from which water actually overflows. In my opinion the question of the area of the impervious stratum must always be taken into consideration in deciding whether a well is "deep" or "shallow"; if, for instance, you have an area of some 15 or 20 square miles of clay some 8 or 10 feet thick overlying a pervious stratum of sand and a well is sunk in the middle of this area, it is more than probable that the water obtained from the well will be of very great purity provided that the collecting ground, that is, the outcrop of the sandy stratum on the edges of the clay, is free of all chances of pollution. However, this is a state of affairs that you are never likely to meet in the plains of these provinces.

I have referred to Artesian wells as being likely to be found, or being possible of construction, in the hilly districts of Chota Nagpur, the Himalayas and Assam. The theory of the supply to these wells is this—Suppose we have a permeable stratum descending from the sides or top of a range of hills down into the valley and probably up the hills on the other side of the valley; and suppose that this permeable stratum is covered by an impervious stratum; then if we sink a well in the valley through the impervious stratum into the pervious stratum, the water will rise up through the well considerably above the level of the bottom of the impervious stratum—in fact it may overflow from the mouth of the well. In temperate climates, where the rainfall is spread over the whole year, the level of water in these wells

and the discharge from them will be fairly continuous the whole year; but in this country, where the rainfall is confined to three or four months of the year, the discharge must vary considerably; during the rains it will be large, but will gradually decrease from the close of one rainy season until the commencement of the next. The waters from deep wells, which as you see include Artesian wells, have been given a high place in the scale of purity, but they are not always fit for potable purposes because they may hold mineral matters in solution which may render them not only unpalatable, but even dangerous to health.

“*Upland surface water*” is water that is collected from rocky mountains which are bare or have but scant vegetation, and mountains and hills that are not only bare of vegetation, but also of dwellings, and this is a most important point. This is a condition of things which is not met with in Bengal, for all the hills are covered with very thick jungle, or if they are not, they are inhabited and cultivated. Even the water flowing from the inhospitable, sparsely-populated, rocky mountains across the North-West Frontier is of a very dangerous character, as has been proved by the very large number of cases of enteric fever that occurred amongst the troops during the recent expedition against the Afridis. I am rather doubtful whether I ought to have included this class of water in my list, but my reason for doing so is to impress upon you the necessity of having collecting grounds free from habitations and vegetation if a very pure natural water is wanted.

We now come to *subsoil water* in wells that are *distant from any collection of houses*. In this definition the word “distant” may, I consider, be understood to mean nothing under  $1\frac{1}{2}$  to 2 miles. This is the source of supply of water to hundreds and thousands of wells that are sunk by District Boards along roads in this country. Fortunately little or no manure is used in cultivation in India: even that which is used consists of cow-dung ashes, and so contains no matter liable to putrefaction, and any disease germs that may have originally been in the cow-dung will have been destroyed in the process of burning. The water as it flows into wells of this class should be of a high standard of purity because it has passed through a large natural filter, but it is liable to pollution from dirty *lotahs* being dipped into it, but this subject of outside pollution will be dealt with later on.

*Land springs* are found where an impervious stratum comes to the surface and throws out the water which has passed through the pervious stratum lying above it. Consequently great care must be taken to see that the collecting ground is not liable to pollution. This source of water-supply is mostly met with in the Himalayas and the hills of Chota Nagpur and Assam. As long as the collecting ground is above suspicion, the water obtained from this source must be of a very high standard of purity, but it is a source which should only be brought into use after a most careful examination of the collecting ground by experts in hygiene and sanitary engineering. A portion, and I am glad to say a very small portion, of the water-supply of a well-known hill station is derived from some small land springs and the water is discharged into the distribution pipes without filtration. Now the collecting ground for these springs is largely used for grazing, and a considerable quantity of the droppings from the cattle must be washed

into the springs, especially when rain falls after a long period of dry weather which has caused small cracks possibly to open in the soil; then there is a much-frequented public road passing right through the collecting ground, and the droppings of horses, dogs and cattle passing along the road are liable to be washed into the springs; lastly, there is a public latrine on the collecting area. In spite of all the chemical and bacteriological analyses that may be produced to show that the water from these springs is wholesome, I have no hesitation in condemning it as an unsuitable, and further as an absolutely dangerous source of supply for drinking water.

In all hilly tracts and mountainous regions the only sources of water are land-springs during the dry weather, and land-springs mixed with surface water during the rainy season. If the collecting grounds of these springs are reserved forests, as they are in Darjeeling, the water-supply will be very much purer during the dry season than during the rainy, for during the latter season the water must necessarily contain a large amount of decaying vegetable matter both in solution and in suspension; in fact, I have heard the water which is supplied to Darjeeling described as "a strong infusion of jungle tea." It is quite probable, though, that slow filtration of this water through sand would yield a water of a very high standard of purity. If any one of you during his career is called on to devise a means of supplying water from a source such as I have just now described, above all things bear in mind the question of the possible pollution, not only of the collecting ground of the spring, but also of the stream formed by the spring along its course; it is of vital importance. Upon this point only depends whether you will have a fairly pure supply of water or an absolutely impure supply of the worst class. A terrible example of the result of supplying water from springs liable to pollution occurred towards the end of the year 1897 in the town of Maidstone in England. The following description of the springs is taken from the Local Government Board Report:—

"*The Farleigh Ragstone Springs.*—These lie to the south-west of the town, rise from the subsoil skirting the two banks of the Medway, and include the following:—

		Gallons per week.
Ewell spring	...	1,540,000
Tutsham-in-Orchard	...	105,000
Tutsham-in-Field	...	35,000
Big Church, South-Eastern Railway	...	105,000
Other South-Eastern Railway springs	...	1,050,000
		<hr/>
Total	...	3,080,000
		<hr/>

"All the springs are derived from more or less shallow sources in the Hythe beds of the lower greensand, known locally as 'ragstone,' which is very liable to be fissured. The springs are not protected in any way, and the gathering grounds of some of them are covered

with heavily manured hop or fruit-gardens, on which many persons are at certain seasons employed. The water is collected by open-jointed underground field-pipes, the situations of some of which are not accurately known, and is conveyed to bricked catchpits with iron covers, which are beneath or a little above the ground level."

The state of affairs which an inspection of the above springs disclosed is thus described:—

"At the Ewell springs he (the Deputy Medical Officer) found two rabbits in one of the catchpits, and human fœces near the cover of two of them. About 50 yards from the Tutsham-in-Orchard spring was a privy in a disgraceful condition, a large deposit of fœces decomposing and flooding the ground with its constituents. The catchpit of the Tutsham-in-Field spring was about 50 yards from a shed occupied by hop-pickers from August the 26th to September 13th, and close to a hedge separating the field from a hop-garden, under which the open-jointed field-drain feeding the catchpit ran for some distance. In the field, and especially near the hedge, were many deposits of human excrement. On September 21st Dr. Washbourn saw fœcal matter in dangerous proximity to the South-Eastern (including Big Church) springs."

In this epidemic there were no less than 1,908 cases of typhoid fever reported between the 1st September and the 20th January, or on an average of 13 cases a day; in the 25 days between the 10th September and 4th October there were no less than 1,270 cases, or an average of nearly 51 cases per day. Epidemics of this sort occur nearly every year somewhere or other, but they seem to have but little effect in causing the local authorities of non-infected places to put their houses in order; nothing is done until disaster overtakes them.

The next lowest water in the scale of purity that I have given you is that derived from *rivers*. I have pointed out that the water of rivers in this country is probably not quite so impure as of those in European countries, principally by reason of the greater volume of the former. As far as possible the discharge into rivers of the night-soil and liquid wastes of towns in this country is prevented, but in spite of every care large quantities of polluting matter must find its way into the rivers; and although the volume of water is generally very large, still under no circumstances could I approve of river water being used as drinking water unless it had been carefully filtered. As far as I am aware, Calcutta is the only town, on this side of India at any rate, which has an unfiltered and filtered water-supply of water derived from a river, but cases of cholera have been traced to the use of unfiltered water laid on to private houses for washing carriages, etc., and the Corporation have within the past year or two replaced unfiltered water at the bathing-platforms by filtered water, so as to prevent, as far as possible, the users of the platforms taking cholera germs into their systems. If for pecuniary reasons it is necessary to supply unfiltered water to a town for road-watering, flushing drains, sewers, etc., the greatest possible precautions must be observed to prevent its being used for domestic purposes. In each class of water that I have brought to your notice I have directed your attention to at least one point which demands your careful enquiry and study before you



can decide whether the water derived from that source would be a safe water for potable purposes, and in the case of river water the point or locality at which the water is abstracted from the river must be carefully thought out. First and foremost, the intake, as it is usually called by water-works engineers, must never be on the down stream side of the town for which the water is required, neither should it be in the middle of the river face of the town, although this is the most economical position, the reason for these prohibitions being that it is not desirable to have the surface drainage from the crowded parts of the town mixed with the water that is to be afterwards drunk. Speaking generally, the slope of the land is away from the river, that is to say, the highest land is to be found on the banks of the river, but actually there is always a strip or fringe of the river bank of varying widths, but never very wide, which slopes towards the river, and it is the drainage of this portion of a town, which is usually the most thickly populated, that has its outfall in the river. Another reason why the intake should be above the town is that the subsoil water under a town is always of a highly polluted character, and the river is the natural outlet of such subsoil water; you will remember perhaps that subsoil water under villages and towns occupies the lowest position as regards purity in the list I have given you. Then, again, care must be taken to see that there are no burning or bathing *ghats* on the upstream side of the intake; or that there are no *ghats* at which country boats are allowed to moor for purposes of taking in or discharging cargo, for all the waste products, including the nightsoil and urine of the crews, are simply thrown overboard. It is an extremely difficult thing to disestablish *ghats* of this character, which have perhaps been in use for generations, and so the better plan is to try and place the intake of any water-supply on their upstream side.

A very large quantity of the drinking and washing water of this country is derived from excavations and ponds that are known generically as tanks, and the source of this water is mostly *surface water from cultivated areas*, although more often than not the water comes from semi-rural areas. The former source of supply is less dangerous than the latter, but the rush of water from either area into tanks after a fall of rain succeeding a prolonged period of dry and rainless weather is of a very impure character, and this is one of the reasons that surface water from cultivated and semi-rural areas is given such a low place in the scale of purity. Another reason is that the surface water when collected is so liable to contamination from bathing and the washing of clothes. *Surface water from cultivated areas* is also obtainable from the drainage channels with which the country is intersected; the main rivers flow on the high lands, and, as I have pointed out before, the general slope of the country is away from these rivers: consequently there must be drainage channels at the bottoms of these slopes into which the surface water eventually falls. The fields surrounding villages and on the edges of big towns are used, as you are all aware, for purposes of defœcation; and although during the dry weather all this fœcal matter may be, and probably is, rendered innocuous by the combined action of the sun and earth, still during the rainy season it must nearly all be washed off by the surface water into the nearest drainage channel; the

fecal matter is deposited daily at all times of the year, and consequently the surface water that flows off the land during the rains receives a daily dose of sewage. I am bound to admit, however, that water is purified to a certain extent both by sedimentation in tanks and by flowing over the surface of land, but at the same time water that has recently been polluted by night-soil or sewage can never be safe for drinking purposes. Drainage channels are therefore not desirable sources of supply of drinking water. Not much choice is allowed in the selection of the site of a tank, because as a rule they are constructed for the convenience of the users, whether the tank has to be used for drinking purposes or only for irrigation, and, I am afraid, quality has very often to give way to utility. Then again tanks are more often than not made in order that the earth obtained from them may be used for raising the level of the surrounding ground, and so that houses may be erected in comparatively dry situations. However, if any choice is given you in the matter, you should endeavour to locate tanks on the upstream side of the village when referred to subsoil water; this will to a certain extent prevent the subsoil water from the village getting into the tank. The direction of flow of the subsoil water can generally be ascertained by observing by means of a level the heights above datum of the water in wells or tanks in the vicinity of the site of the proposed tank during the hours of least draught on the well; roughly speaking, the direction of flow is towards the nearest river that is not merely a drainage channel. You should excavate the tank to the very lowest level that you can get down to during the driest season of the year; this will ensure a greater proportion of comparatively pure subsoil water coming into the tank to dilute the impure surface water. And finally, if funds are available, I would recommend you to sink one or more wells, as deep as possible, in the bed of the tank, which may have the effect of creating a flow of subterranean or deep-well water into the tank by reason of its higher temperature; but, in spite of all these precautions and expedients, I am afraid that *surface water from cultivated areas* as collected in tanks in Bengal must always be of a very low standard of purity.

We have now reached the least pure of all the sources of supply, namely *subsoil water under towns and villages*, and it is from this source, I regret to say, that at least three-quarters of the population of these provinces obtain their drinking water. In villages perhaps the subsoil water which passes under them is not of quite as impure a character as that which passes under towns, because in the former all fecal matter is voided over the surrounding fields, where the beneficent heat of the sun, the fresh air, and the upper layers of the soil quickly render it comparatively innocuous, and it is only the cooking water and liquid wastes of a household which soak into the ground; in towns, however, the night-soil, urine and liquid wastes are more often than not run into wells or cesspools excavated for the purpose in the courtyards of houses, and these most objectionable matters are thus thrown into direct contact with the subsoil water without having been subjected to any purifying process whatever. I am fully aware that in all municipal towns every endeavour is made by the Commissioners to convey the night-soil and liquid wastes as far away as possible from the

inhabited portions of the towns, but I regret to say that in many cases much opposition is shown to these good endeavours by the inhabitants themselves, and I do not think that I shall be exaggerating when I say that in most towns only about one-half of the night-soil and one-quarter of the liquid wastes are ever properly removed; the balance must go somewhere, and it goes to pollute the subsoil water. The germs of cholera and typhoid will lie dormant in the soil for years; and when once the soil has been infected with these germs, it is hopeless to try and get pure water from wells whose source of supply is the subsoil water; nothing short of the absolute removal of the town would accomplish so desirable an end, and this we know is beyond the bounds of possibility, and so we must devote our energies to mitigating the evil as far as possible by not adding fuel to the flame; that is to say, we must endeavour by all the means in our power to stop the further pollution of the subsoil water in town areas by closing all these cesspools, and providing means for purifying the liquid wastes and removing them from the houses in carefully constructed surface drains. The method of doing this will be dealt with in the section of these lectures which deals with conservancy.

#### THE QUALITY OF WATER.

So far we have only discussed the various sources of water, but before we can make use of the water we must make enquiries as to its quality and quantity. The actual examination of a water as to quality and suitability for potable purposes should always be carried out by a medical officer, and his advice alone should be relied on. Here in Bengal the matter may also be referred to the Sanitary Board, which has as members the highest experts in hygiene and sanitary engineering at the disposal of Government. But you may be called upon to take samples of water for the medical officer to analyse, although as a rule it is more desirable that the person who makes the examination should also take the samples, and instructions as to how these samples should be taken will not, therefore, be out of place in these lectures. The leading text-book on the theory and practice of hygiene is that by Notter and Firth, and I think I cannot do better than quote what is said on the subject of collection of samples by such high authorities:—

“Great care must be taken that a fair sample of the water is collected in perfectly clean glass vessels (not in earthenware jars). Winchester quarts, which hold about half a gallon, and can be obtained of most chemists, are most convenient; they should be repeatedly washed out with some of the water to be examined. In taking water from a stream or lake the bottle ought to be plunged below the surface before it is filled. In drawing from a pipe a portion ought to be allowed to run away first, to get rid of any impurity in the pipe. In judging of a town-supply, samples should be obtained direct from the mains, as well as from the houses. The bottle should be stoppered; a cork should be avoided, except in great emergency, but if used it should be quite new, well tied down, and sealed. No luting of any kind (such as linseed meal and the like) should be used.”

“For a complete sanitary investigation half a gallon is necessary, but with a litre or a couple of pints a pretty good examination can be made if more cannot be obtained. If a detailed mineral analysis is required (which will only be seldom), a gallon ought to be provided. It is always advisable to have a good supply in case of breakage or accident; two Winchester quarts of each sample will generally be found sufficient. The examination ought to be undertaken immediately after collection, if possible. If this cannot be done, then as short a time as may be should be allowed to elapse, for changes in the most important constituents take place with great rapidity. Pending examination it ought to be kept in a dark cool place.”

And now we come to the most important part of the extract, to which you must pay the greatest attention—

“The fullest information ought always to be furnished with the sample, the following being the most important particulars:—

- (a) Source of the water, *viz.*, from tanks or cisterns, main or house pipe, spring, river, stream, lake or well.
- (b) Position of source, strata so far as they are known.
- (c) If a well, depth, diameter, strata through which sunk, whether imperviously stined in the upper part, and how far down. Total depth of well and depth of water to be both given. If the well be open, furnished with cover, or with a pump attached.
- (d) Possibility of impurities reaching the water; distance of well from cesspools, drains, middens, manure heaps, stables, etc., if drains or sewers discharge into streams or lakes; proximity of cultivated land.
- (e) If a surface-water or rain-water, nature of collecting surface and conditions of storage.
- (f) Meteorological conditions with reference to recent drought or excessive rainfall.
- (g) A statement of the existence of any disease supposed to be connected with the water-supply, or any other special reason for requiring analysis.

Any further information that can be obtained will always be useful. Each bottle should also be distinctly labelled, so as to correspond with the official letter or invoice.

When it is possible, it is most desirable that the medical officer or analyst should visit the locality itself whence the water is obtained; in this way he may obtain information which might otherwise escape him. If the analysis can be made immediately on the spot, it will be all the more valuable.”

You cannot be too careful or too accurate in describing to the best of your ability the sources of supply of any samples that you may be called upon to collect, because water that is collected from a polluted area or one that is liable to contamination must always be classed as dangerous, even although analyses, both chemical and biological, may show that the sample is one of potable water. You will remember my description of the collecting ground of some springs in a hill station, how it was used for grazing, and had a much-used public road passing through it, and

that, worst of all, there was a public latrine on it; the Municipal Commissioners forwarded a sample of the water issuing from this spring to the Chemical Examiner, but it was not accompanied by a description of the collecting ground. The analysis showed that the water contained in the sample was potable; but, gentlemen, the analysis of one sample of a water collected from an area that is manifestly liable to pollution proves nothing, and is not worth the paper that it is written on; all that the analysis in such a case would prove would be that the particular sample was potable and not the whole water-supply. An analysis of a sample of water such as I have described is not only useless, but it is worse than useless, because it leads people who do not understand anything about water analyses—and they form the majority of the consumers—into a false sense of security. In the case of the Farleigh springs at Maidstone, which I have already described to you, the Corporation of that town were quite satisfied with the results of analyses of samples taken four times a year, and yet we have seen what were the terrible results of the false sense of security brought about by these analyses; the springs were liable to pollution, and the disastrous epidemic of typhoid was not stopped until the water from the springs was cut off. The following extract is taken from the Local Government Board report on the Maidstone epidemic:—

“The specific pollution of typhoid fever, which is certainly beyond the reach of chemistry and also of bacteriology, to detect, may escape detection in a water in which it is nevertheless present. Further, it has to be borne in mind that detection of a specific pollution of a supply may come too late to prevent the consumption of the contaminated water. *Clearly chemical analyses and bacteriological examinations should be supplemented by skilled inspections of the actual conditions, geological, topographical, and sanitary, of the surroundings of the sources of supply.*”

The italics are mine.

Mr. Hughes in the course of the lectures which he delivered in this College quoted the case of a similar epidemic at Worthing in 1893. Seventeen hundred cases of typhoid occurred in this town, which is a favourite seaside place of residence, with very healthy surroundings; the water was carefully analysed both chemically and biologically, and the analyses gave most satisfactory results; it was eventually found that the wells from which a portion of the water-supply was derived was being polluted with surface drainage and leakage from a defective sewer. The cases of Maidstone and Worthing are by no means exceptional, for in nine cases out of ten the history of typhoid epidemics shows that the outbreaks have been due to a polluted water-supply; in this country, however, not only is a polluted water-supply responsible for typhoid, but to it can generally be traced the terrible epidemics of cholera that are the scourge of the hard-working and poverty-stricken inhabitant of this country. It therefore behoves us to be doubly careful out in India of our sources of water-supply, and if I weary you by my repeated warnings against the pollution of sources of water-supply, it is because I am satisfied that three-quarters of the sickness and misery that we see around us on all sides is due to this cause. Once more let me repeat that the report on the chemical or biological analysis of a sample of water is useless unless the sample has

been accompanied, at the time of despatch to the analyst, by a minute and correct description of the surroundings and present condition of the source of supply of the water from it was taken.

#### THE QUANTITY OF WATER.

We must now take up the question of gauging the quantity of water available from the sources of supply which I have brought to your notice. In temperate climates, where rainfall occurs at all times of the year, the measurement of the yield of springs and wells is a long and tedious process involving a course of rainfall observations and measurements of discharge over a very prolonged period, not of days or weeks, but often of months and years, because we must obviously ascertain not the maximum, or even the average, discharge, but we must find out the absolutely minimum discharge that may be expected after a prolonged drought or absence of rainfall. The consumption of water per day in any one town or village is a constant quantity, but the rainfall that replenishes the springs and wells is not constant by any means, and so all calculations have to be based, in temperate climates, on the minimum discharge observed during a period of four or five years. In this country, however, we all know that the rain which causes the rivers to flow full to their brim, and which replenishes the vast underground sea of subsoil water and causes the level of such water to rise, falls only during certain months of the year, so that if we make our observations as to levels and discharges just before the first downpour of the rainy season, we shall obtain results which are sufficiently accurate for all practical purposes. There are of course some years in which the rainfall is below the normal, but there are no recorded observations, as far as I am aware, except those at Umballa, of the effect of short rainfall on the discharge of springs or the level of the subsoil water; in the case of springs a short rainfall may reduce the discharge to a certain extent, but in the case of the subsoil water, the level of which really depends on the heights of the water in the rivers to which it is always flowing, I am inclined to think that the minimum level is practically the same after a season in which the rainfall has been below the normal as after one in which an abnormal quantity of rain has fallen. I do not wish to be understood to say that the minimum level of the subsoil water is absolutely fixed, because we do hear of wells and tanks becoming dry during an abnormally hot year, but what I do believe is that if we observe the level of the subsoil water in any one year we can so construct our tanks and wells that they will never run dry, or, in other words, that the variation of the minimum levels of subsoil waters cannot be measured in feet. Consequently I am of opinion that the minimum flow of a deep spring in this country is not likely to vary much from year to year. In conducting all enquiries as to minimum flows and levels you should always refer to the inhabitants of the villages in which your enquiries are being made, because I have found in course of my inspections that much useful information in this respect is handed down from generation to generation.

The water of *deep springs* is generally found just welling-up through a hole in the ground, and the most convenient way of gauging

the outflow will be by arranging that it shall be discharged through a small masonry or other impervious channel, and then observing by means of floats the maximum surface velocity from which it will be easy to deduce the mean velocity. The method of calculating the discharge of channels has been explained to you in the lectures on hydraulics, but it will not be out of place to reproduce the leading equations here—

Let  $V_m$  = the mean velocity.

$V_o$  = the greatest surface velocity.

$C$  = a co-efficient depending on the roughness and form of the channel (Darcy and Bazin's co-efficient).

$$\text{Then } V_m = \frac{C}{C + 25.4} V_o.$$

The following table of the values of the co-efficient  $\frac{C}{C + 25.4}$  in the above formula, taken from Professor W. C. Unwin's article on hydromechanics, will probably be of use:—

Hydraulic mean depth.	Very smooth channels with cement plaster.	Smooth channels in brick work.	Rough channels in rubble masonry.	Very rough channels in earth.
0.25	0.83	0.79	0.69	0.51
0.50	0.84	0.81	0.74	0.58
0.75	0.84	0.82	0.76	0.63
1.00	0.85	...	0.77	0.65

From the values given in the table you will see that for the first two classes of channel—and these are probably the channels that you will have most to do with—the value of the co-efficient is about 0.80, while for a rougher channel in rubble masonry the value is about 0.70, while for a very rough channel in earth it is about 0.60. If you desire very great accuracy, you may work out the value of the co-efficient for other values of the hydraulic mean depth, but for all practical purposes the mean velocity of a stream flowing in a masonry channel may be taken as 0.8 times the surface velocity, and in an earthen channel as 0.7. The channel in which the gauging is carried should be 30 or 40 feet long, so that the stream of water may be as steady and free from eddies as possible. As regards floats, you will probably find that flat discs of wood will be as useful as anything; you require a pattern of float that will not be caught by the wind, and for rough purposes a chip of wood or cork will be quite good enough.

If the source of supply is a *deep or shallow well*, the water, except in the case of true Artesian wells, has to be raised to the surface by mechanical means. The flow from Artesian wells can be measured in the manner I have just described for deep springs, but that from

other wells is more conveniently measured by causing the water to pass over a notch or weir. I have frequently seen it stated that the easiest way to measure the yield of a well is to reduce the level of the water in it by pumping or otherwise, and then observe how long it takes the water to regain its normal level. This may be an easy way, but it gives very misleading results; at least, I found it so when testing the yield of a well at Patna; in that case I found that by lowering the surface of the water in the well about four feet I could get a discharge of 5,400 gallons per hour for as long as I liked, but that the discharge calculated in the manner I have referred to above worked out to only 800 gallons per hour. You have been told elsewhere that motion is produced in water by the differences of level in the free surface; such difference being generally known as the "head," and that water consequently will always flow from a higher level to a lower; therefore, if the level of the water in a well is below that of the subsoil water outside, motion must take place, and so the water in the well is replenished and brought up to the same level as that of the subsoil water; the greater the difference in level the greater the pressure and therefore the velocity of the water; so that the water will flow into the well at a gradually diminishing rate, and all that we should get by noting the time of replenishment would be an average rate, and not an actual possible discharge. The correct method of ascertaining the yield of a well is to arrange, either by pumping or bailing, to keep the water in the well at some fixed level below that at which it normally stands; the differences in level should be small at first, and should be gradually increased from day to day or week to week until it is found that the rush of water into the well is strong enough to bring in sand and so raise the level of the bottom of the well; while, therefore, pumping or bailing is going on constant soundings must be taken to see that there is no inrush of sand. The rate of yield of the well will then be the quantity of water that can be abstracted continuously without disturbing the soil or sand in which the well is sunk. In addition to measuring the quantity of water which can be got out of the well you must also observe the effect that this continuous abstraction of water has on neighbouring wells within radii, increasing, say, by 250 or 300 feet; if you are testing a small well in a town you will have to take the existing wells and make observations of the level of the water in them, but if your enquiries are being conducted with a view to a possible supply for a whole town, you can sink these observation wells at regular intervals. In either case, however, you should make an accurate plan showing the positions of all the wells with regard to the main well the yield of which you wish to ascertain. It will be instructive, I think, if I give you an account of an experiment on the yield of a well at Patna which was carried out under my direction during May 1897; the results were so satisfactory that I am now preparing a scheme of water-supply for the city of Patna in which it is proposed to obtain the whole of the water entirely from wells.

The experiment was made with a view to ascertaining whether it would be possible to obtain a supply of drinking water from wells sunk in the old bed of the river Sone, which, if tradition and ancient maps are to be believed, used to flow at one time much more to the east of



its present position, and actually joined the Ganges close to what is now known as the civil station of Bankipore. You will better understand the advantages of such a source of supply when I have spoken to you about the various works connected with schemes of water-supply for large towns, and so I shall refer to this well again later on; at present we are only considering the question of gauging the yield of wells. A little while ago I spoke to you of the value of local traditions in the matter of the supply of springs and wells, and I found these very useful when I was called in to select the site for the experimental well. Before my arrival on the spot several borings had been sunk with the most unsuccessful and hopeless results, as the boring tool had simply gone through 50 or 60 feet of stiff clay, and in several places without reaching a drop of water, and this in the month of April, when the subsoil water was by no means at its lowest level. As soon as I was informed of this, I asked to be shown some of the wells in the locality which were used for irrigation purposes, and the very first one that I examined was found to have its bottom in what was undoubtedly river sand, and the water was standing a few feet below the surface; and it was the same with several others. This, to me, was conclusive evidence that these wells were obtaining their supply of water from the old bed of a river, and the inhabitants all stated that the water was that of the Sone. I therefore ordered a boring to be made in the neighbourhood of one of these existing wells on a spot of high ground which would be suitable for a pumping station, and the result was that fine sand was found at 6 feet, water at 12 feet, and coarse sand with pebbles at 20 feet below ground level, the pebbles showing unmistakable signs of having been worn by water. Several other borings were sunk, and all with the same results. Plate No. 1 shows in diagrammatic form the strata through which the boring-tool passed, and the sites of the borings. From this plate you will see how the main experimental or pumping well was surrounded by a series of observation wells for ascertaining the effect of lowering the water in the main pumping well.

The main pump-well was four feet four inches internal diameter, and was sunk to a depth of thirty-one feet ten inches below ground level; it was lined throughout with brick set in lime mortar, so that water should, as far as possible, only enter the well through the bottom, the area of which was a known quantity; this will enable me to say with a fair degree of accuracy what area of wells will be required for the larger supply of water that will be required for the city of Patna. At the sites of all the other borings wells with ordinary country-made earthenware rings were constructed and used as observation wells. Now these observation wells serve two purposes: they indicate the direction of the flow of the underground or sub-soil water, and they also show whether water is being abstracted from the well more quickly than it can flow through the sub-soil. From the diagram you will be easily able to see that the flow of sub-soil water is from south to north because the level of water in the wells to the south of the main pump-well is higher than that in those to the north. If water had been abstracted from the pump-well more quickly than it could flow through the soil, the levels of the water in the wells on all sides would have been depressed while pumping was going

on. In some similar experiments that were carried out at Gaya some years previously the observation wells consisted simply of a series of two-inch pipes sunk vertically into the ground, but in my opinion these were much too small, because the mere skin-friction would be sufficient to hold up the water in the pipe, and so prevent its true level being ascertained. All the wells were fitted with floating gauges, so that the levels of the water could be read off easily at any hour of the day.

For lifting the water out of the pump-well one pulsometer and one duplex pump were provided; the pumping machinery was provided in duplicate, so that there might be no interruption of the operations owing to the breakdown of a pump. The water was delivered into a brick masonry tank measuring  $5' \times 2' \times 3'$  built at the side of the well, the idea being that any intermittent delivery of water by the pumps should be steadied down before the water reached the point where its quantity was to be measured, and also that the tank should act as a catch-pit for any sand that might be brought up by the pumps. The water flowed from this tank over a broad notch or weir into a masonry trough twenty feet long and two feet broad and two feet deep. At intervals along this trough baffle-boards were built into the masonry, over and under which the water flowed so as to ensure having a smooth water surface, but owing to the height of the weir in the delivery tank above the trough, even these were not found sufficient, and one end of the trough had to be partially filled with broken bricks. In any future experiments of this kind I should feel inclined to connect the tank and the trough by an orifice cut in the tank at the level of the bottom of the trough; this arrangement would probably give a much steadier flow into the trough, as the water would not come out of the tank in waves. Near the end of the trough a wrought-iron plate was fixed in which a right-angled triangular notch six inches deep, and therefore twelve inches wide at the top, was cut, and over this all the water had to pass, as it left the trough. For small streams a triangular notch is much to be preferred to one of a rectangular pattern, because in the latter the relation of the breadth of the stream passing over the notch to its height is never a constant quantity, and consequently the co-efficient of discharge would never be a constant quantity. The experiments of Professor James Thompson have shown that a triangular notch gives much more accurate results than a rectangular one. The formula which gives the discharge over a right-angled triangular notch is

$$Q = 2.54 H^{\frac{5}{2}}.$$

where  $Q$  is the discharge in cubic feet per second; if the discharge is to be given in gallons per hour ( $G$ ), then the formula will be

$$G = 57059 H^{\frac{5}{2}}.$$

where  $H$  is the height in feet of the free water surface above the notch at a point where it is not affected by the fall due to the notch; with a notch such as I have described the gauge should be fixed about three feet above the notch on the upstream with its zero on a level with the lowest point of the notch.

The following table giving the discharges of a right-angled triangular notch in gallons per hour will probably be found useful:—

*Discharge of a right-angled triangular notch.*

Gauge.	Gallons per hour.	Gauge.	Gallons per hour.	Gauge.	Gallons per hour.	Gauge.	Gallons per hour.	Gauge.	Gallons per hour.	Gauge.	Gallons per hour.
0'01	0'1	0'11	229	0'21	1,154	0'31	3,053	0'41	6,138	0'51	10,596
'02	3	'12	285	'22	1,295	'32	3,382	'42	6,522	'52	11,130
'03	9	'13	318	'23	1,448	'33	3,510	'43	6,918	'53	11,670
'04	18	'14	418	'24	1,610	'34	3,846	'44	7,326	'54	12,228
'05	32	'15	497	'25	1,784	'35	4,136	'45	7,752	'55	12,798
'06	50	'16	584	'26	1,967	'36	4,433	'46	8,190	'56	13,392
'07	74	'17	680	'27	2,161	'37	4,752	'47	8,646	'57	13,998
'08	103	'18	784	'28	2,368	'38	5,080	'48	9,108	'58	14,616
'09	139	'19	898	'29	2,645	'39	5,421	'49	9,594	'59	15,258
'10	180	'20	1,021	'30	2,813	'40	5,775	'50	10,086	'60	15,918

From this table you will see that a 6" notch is capable of discharging a very large quantity of water, and it is hardly likely that you will ever be called on to gauge the yield of a well giving the maximum discharge shown in these tables. For a discharge of 10,000 gallons an hour, a notch 5" deep would be quite big enough.

The water that was discharged over the notch was carried far away in an earthen channel carefully made of pugged clay so as to prevent the water soaking back into the pump-well.

I have already explained that the motion of water entering a well is due to the "head" or difference of level between the subsoil water and that in the well, and the following table shows the different "heads" on the water in the well, the number of hours during which such "head" was maintained, and the discharge per hour while pumping was continued. As a rule, the pumps were at work from 10 to 10½ hours daily; but when the number of hours during which the fixed head was maintained was less than 10 hours, the balance of the time was taken up in lowering the surface of the water so as to obtain the required "head" on the well:—

*Statement of daily average discharge.*

DATE.	Average head on well.	Number of hours average head was maintained.	Average daily discharge in gallons per hour.	Average head in round numbers.	Average discharge in gallons per hour.	REMARKS.
May 1st 1897	1'50	10	2,842	} 1'50	2,602	
" 2nd "	1'67	10¾	2,652			
" 3rd "	1'67	10	2,475			
" 4th "	1'50	10¼	2,439			

## Statement of daily average discharge—concluded.

DATE.	Average head on well.	Number of hours average head was maintained.	Average daily discharge in gallons per hour.	Average head in round numbers.	Average discharge in gallons per hour.	REMARKS.
May 5th 1897	2.00	10 $\frac{1}{4}$	3,000	2.00	2,906	
" 6th "	2.00	10 $\frac{1}{4}$	2,800			
" 7th "	2.00	10 $\frac{1}{4}$	2,871	2.50	3,354	
" 8th "	2.00	9 $\frac{1}{4}$	2,953			
" 9th "	2.50	10 $\frac{1}{4}$	3,044	4.00	5,408	
" 10th "	2.50	10	3,354			
" 11th "	2.32	10 $\frac{1}{4}$	3,435	5.00	4,796	Well sank, 2' 0" stone-metal thrown in.
" 12th "	2.48	10 $\frac{1}{4}$	3,397			
" 13th "	2.53	10	3,366	6.00	5,531	
" 14th "	2.59	9 $\frac{3}{4}$	3,456			
" 15th "	2.62	9 $\frac{3}{4}$	3,423	7.00	5,355	Well sank, 6" stone-metal thrown in.
" 16th "	4.00	7 $\frac{3}{4}$	5,510			
" 17th "	4.03	9 $\frac{3}{4}$	5,292	8.00	5,758	Well sank.
" 18th "	4.04	9 $\frac{3}{4}$	5,423			
" 19th "	5.02	8 $\frac{1}{2}$	5,601	8.00	5,758	
" 20th "	5.04	9 $\frac{1}{2}$	4,338			
" 21st "	4.98	9	4,139	8.00	5,758	
" 22nd "	5.02	2 $\frac{1}{2}$	5,106			
" 22nd "	6.12	6	5,723	8.00	5,758	
" 23rd "	6.12	9	5,504			
" 24th "	6.08	8 $\frac{1}{2}$	5,338	8.00	5,758	
" 25th "	6.06	8 $\frac{1}{2}$	5,508			
" 26th "	7.01	8 $\frac{1}{4}$	5,460	8.00	5,758	
" 27th "	7.02	8 $\frac{1}{4}$	5,795			
" 28th "	7.03	8 $\frac{3}{4}$	5,288	8.00	5,758	
" 29th "	7.02	8 $\frac{3}{4}$	4,878			
" 30th "	8.05	8 $\frac{3}{4}$	5,247	8.00	5,758	
" 31st "	8.03	8 $\frac{1}{4}$	5,036			
June 1st "	8.02	8 $\frac{1}{2}$	5,524	8.00	5,758	
" 2nd "	8.02	8 $\frac{1}{4}$	5,413			
" 3rd "	7.98	5	6,185	8.00	5,758	
" 4th "	...	...	...			
" 5th "	7.94	8 $\frac{1}{4}$	6,546	8.00	5,758	
" 6th "	7.94	8 $\frac{1}{2}$	6,355			

The bottom of the well was not weighted when pumping was first started, and it was not until the 13th May, while the well was being worked with a head of 2.50 feet, that the sand began to rise; on the 18th May the sand has risen 8" only, but on increasing the head from 4.0 to 5.0 on the 19th May the well sank 2 $\frac{1}{2}$ " and the sand rose 3 feet; it therefore became necessary to weight the bottom of the well with stone-metal, with the result that, although the head was increased, the yield was less, as may be seen from the above statement. On the 28th May the well sank  $\frac{1}{4}$ ", and more stone-metal had to be spread over the bottom, with the result that the yield was reduced from 5,288 gallons per hour on the 28th May to 4,878 gallons per hour on 29th. On the

3rd June an attempt was made to work the well at a 10 feet head, but after two hours' pumping with this head the well sank. It would therefore appear that the most suitable head on the well was 4.00 feet, which gave a discharge of 5,400 gallons per hour, or .016 cubic feet per second per square foot of area of the well.

The time taken for the water surface to rise in the well after pumping had been stopped was observed daily, and the following table has been abstracted from the daily reports:—

6" depths rising from lowest level of water.	TIMES IN MINUTES.							
	Head, 1.5	Head, 2.00	Head, 2.50	Head, 4.00	Head, 5.00	Head, 6.00	Head, 7.00	Head, 8.00
	Date, 3-5-97.	Date, 7-5-97.	Date, 14-5-97.	Date, 16-5-97.	Date, 19-5-97.	Date, 24-5-97.	Date, 29-5-97.	Date, 2-6-97.
1st ...	1½'	1½'	1'	½'	1'	1'	1'	1'
2nd ...	2½'	2'	1'	1'	1'	1'	1'	1'
3rd ...	6'	2½'	2½'	1'	1'	1'	1'	1'
4th ...	...	7½'	3½'	1'	1'	1'	1'	1'
5th ...	...	...	41'(?)	1½'	1'	1'	1'	1'
6th ...	...	...	...	2'	1½'	1'	1'	1'
7th ...	...	...	...	5'	2½'	1½'	2'	1'
8th ...	...	...	...	15'	2½'	2'	2'	1'
9th ...	...	...	...	...	5'	2'	2'	1'
10th ...	...	...	...	...	20'	3½'	2½'	2'
11th ...	...	...	...	...	...	5'	2½'	2'
12th ...	...	...	...	...	...	20'	4'	3'
13th ...	...	...	...	...	...	...	4'	3'
14th ...	...	...	...	...	...	...	20'	4'
15th ...	...	...	...	...	...	...	...	8'
16th ...	...	...	...	...	...	...	...	29'
Totals ...	10'	13½'	49'(?)	27'	36½'	40'	45'	60'

Average rate of replenishment in cubic feet per minute = 2.13  
 Ditto ditto in gallons per hour = 798

In this table the time taken for the replenishment of the last six inches on the 14th May is evidently wrong, and the mistake was probably due to the floating gauge having got stuck.

The gauges of the observation wells were read three times a day—the first time just before the pumps were started, the second time about the middle of the period of pumping, and the third time just before pumping was stopped, but on no occasion did the lowering of the level of the water surface in the pump-well have any effect on the water surface in the auxiliary wells. Towards the end of May four more wells were sunk within a radius of 50 feet of the pump-well, and the

average of observations extending over the last eleven days of the experiment, when heads of 7 and 8 feet were being used, shows a lowering of the water surface in them, while pumping was going on, of 0.10 foot only.

The total cost of the experiment was as follows:—

				Rs.
Borings	...	...	...	500
Wells	...	...	...	1,500
Tools and plant	...	...	...	1,800
Coals, oil, and stores	...	...	...	400
Labour	...	...	...	300
				<hr/>
		Total	...	4,500
				<hr/>

I have now placed before you the details of an experiment in ascertaining the yield of a well as actually carried out, and if you are ever called upon to make a similar experiment, I think you cannot do better than carry it out on these lines. As regards small Municipal or District Board wells, it is not probable that you will ever find it necessary to gauge their yields, because they are as a rule only used by a few persons at a time, and the water that is drawn out is replaced before the next draw is made. In deciding what size of well to construct, you cannot go into any question of yield, of course, until after the well has been constructed, and so you should just sink a well of the smallest practicable diameter, that is to say, of the size of the ordinary baked earthen ring, and then if the yield from this is not sufficient, a second, or even third, well should be sunk, or if the original well can be thrown out of use, a masonry well of large diameter might be sunk round the original well.

We now come to the consideration of the measurement of the quantity of water yielded by *land springs*, such as may be found in the Darjeeling or Chota Nagpur Hills. The measurements would of course be made at the driest season of the year, that is, just before the setting in of the rains, and consequently in most cases the quantity of water to be gauged would be small; for instance I had occasion in May 1897 to gauge the springs or *jhoras* from which the water-supply of Darjeeling is obtained, and I found that the maximum discharge from any one spring was only 2,567 gallons an hour, or 0.11 cubic foot per second. Where only such small discharges have to be dealt with, the easiest method of measurement is to observe the time taken to fill a vessel of known capacity; for very small springs a kerosine oil tin will be found as useful and handy as anything else, because its exact cubical contents can be calculated; for larger springs, such as the Darjeeling ones, specially-constructed rectangular tins of two cubic feet capacity were used. In making these observations care must be taken to arrange that there should be as little leakage as possible in the sides of the channel in which the spring runs, and also that the water should be delivered with

a free overfall into the measuring box, so as to prevent any water escaping down the sides of the tank and the box. In Darjeeling the springs are made to discharge into artificial reservoirs formed by building a masonry dam across the bed of the stream or *jhora*; closing the outlet pipe through which the water is conveyed to the town causes the water to flow out of the overflow pipe or over the overflow weir, from both of which it was a very easy matter to get the water to fall freely into the measuring boxes.

For springs or streams the flow of which is too large to be measured by the method I have just described, the notch-gauge method must be resorted to, and the following description taken from Tudsbery and Brightmore's work on Water-works Engineering will show how it should be carried out:—

“The dry-weather flow of small streams and those of larger size, when a suitable fall exists in their beds, may be accurately measured by causing the water to pass over a notch-gauge. This apparatus consists essentially of a wide slot or depression in the upper edge of a vertical plate or board, placed across the stream, normally to its axis. The maximum quantity that can be measured by a notch depends upon its length and the fall that can be obtained for the water from its upstream to its downstream side. On the upstream side, to prevent the water from approaching the notch with sensible velocity, it is desirable that the channel should be wider and deeper than the notch; so that the body of water above it may be practically quiescent. If the area of the water, as it passes through the notch, be more than one-fifth part of the area of the channel of approach, the velocity of approach must be taken into account in calculating the discharge over the notch. To avoid sensible velocity of approach, the depth of water below the sill of the notch on the upstream side should be at least three times the depth of water flowing over the notch, and the sides of the approach channel should be distant a like amount from the ends of the notch. By a notch 20 feet long, when a fall of one foot in the bed of the stream can be secured, a flow of 20,000,000 gallons per day may be conveniently measured. Larger quantities than this may be gauged by notches; though for such considerable flows it is generally desirable to resort to current-meter observations, or to the method of gauging by float measurements.

“To construct a notch-gauge a water tight weir is first made across the stream, and in this is set a frame of wood or metal, on the upstream side of which are attached thin metal plates, forming the edges of the gauge. The latter need not be bevelled on the downstream side, if they present a square  $\frac{1}{4}$ -inch edge on the vertical plane. In the common rectangular notch-gauge, three plates are used—one of them forming the sill and the others the vertical ends of the notch. The sill is fixed level, and its length must be accurately known. The notch may be provided with moveable sides, in order that its width may be reduced when the flow is small, as it is undesirable that the height of water over it should be less than about 4 inches. The level of the water on the downstream side must be sufficiently below the sill—not less than one-half the maximum depth of water flowing over it—to allow for access of atmospheric air under the discharging stream.”

Numerous experiments have been made to ascertain a correct value of the co-efficient of discharge, and probably the most accurate of the formula is that given by Mr. J. B. Francis, but even this is only accurate for notches over 2 feet long and for depths of water varying between 1.6 foot and 0.6 foot. Francis's formula is—

$$Q = 3.33(l - 0.1nH) H^{\frac{3}{2}}$$

where  $n$  is the number of end contractions, *i.e.*, in an ordinary rectangular notch  $n=2$ ,  $Q$ =cubic feet per second,  $l$ =length of weir in feet, and  $H$ =height in feet of the free-level of the water, above the bottom-edge of the notch, at a point far enough away to be unaffected by surface-curvature.

For rough comparative calculations the formula for a rectangular overfall notch may be put in the form—

$$Q = \frac{1.0}{3} l H^{\frac{3}{2}}$$

the symbols being the same as in the Francis' formula. If the discharge is required in gallons per hour, the formula becomes—

$$G = 74,880 l H^{\frac{3}{2}}$$

The following table gives the discharges in cubic feet per second and gallons per hour for given depths over each lineal foot of notch :—

*Table of Discharges of a thin-edged rectangular notch per lineal foot.*

DISCHARGE.			DISCHARGE.			DISCHARGE.		
Head.	Cubic feet per second.	Gallons per hour.	Head.	Cubic feet per second.	Gallons per hour.	Head.	Cubic feet per second.	Gallons per hour.
0.04	.027	599	.19	.276	6,200	.48	1.109	24,906
.05	.037	839	.20	.298	6,694	.50	1.179	26,479
.06	.049	1,101	.22	.344	7,729	.52	1.250	28,081
.07	.062	1,385	.24	.392	8,806	.54	1.323	29,717
.08	.075	1,692	.26	.442	9,928	.56	1.397	31,384
.09	.090	2,022	.28	.494	11,029	.58	1.472	33,076
0.10	.105	2,368	.30	.548	12,303	.60	1.549	34,810
.11	.122	2,733	.32	.597	13,403	.62	1.627	36,560
.12	.138	3,116	.34	.661	14,850	.64	1.707	38,345
.13	.156	3,513	.36	.720	16,178	.66	1.787	40,152
.14	.175	3,923	.38	.781	17,539	.68	1.869	41,986
.15	.194	4,351	0.40	.843	18,946	0.70	1.952	43,864
.16	.213	4,793	.42	.907	20,385	.72	2.036	45,751
.17	.234	5,249	.44	.973	21,858	.74	2.122	47,677
.18	.255	5,722	0.46	1.040	23,362	.76	2.209	49,614



*Table of Discharges of a thin-edged rectangular notch per lineal foot—concluded.*

Head.	DISCHARGE.		Head.	DISCHARGE.		Head.	DISCHARGE.	
	Cubic feet per second.	Gallons per hour.		Cubic feet per second.	Gallons per hour.		Cubic feet per second.	Gallons per hour.
·78	2·296	51,583	·3	4·941	111,000	·7	14·789	352,210
0·80	2·385	53,580	·4	5·522	123,410	·8	15·618	350,840
·82	2·475	55,604	·5	6·124	137,560	·9	16·462	369,830
·84	2·566	57,651	·6	6·746	151,920	3·0	17·321	389,140
·86	2·658	59,718	·7	7·388	166,000	·1	18·194	408,700
·88	2·752	61,816	·8	8·050	180,850	·2	19·081	428,650
0·90	2·846	63,930	·9	8·730	196,120	·3	19·983	448,960
·92	2·941	66,085	2·0	9·428	211,790	·4	20·898	469,470
·94	3·038	68,250	·1	10·144	227,880	·5	21·826	490,350
·96	3·135	70,437	·2	10·877	244,800	·6	22·768	511,450
·98	3·234	72,661	·3	11·627	261,220	·7	23·724	532,970
1·00	3·333	74,880	·4	12·394	278,420	·8	24·692	554,760
·1	3·846	86,398	·5	13·176	296,010	·9	25·673	576,770
1·2	4·382	98,447	·6	13·975	313,980	4·0	26·667	599,110

From this table you will see that a rectangular weir only one foot wide can pass a great deal of water, and it is hardly likely that you will ever be called upon to gauge such a large discharge as 599,110 gallons per hour for water-supply purposes, but these tables may also be used by those employed in irrigation or drainage works.

It may so happen that you may have to gauge the water flowing over a notch in a masonry wall to which the above table would be inapplicable, as it only gives discharges over sharp-edged weirs; in that case the discharge in cubic feet per second would be given by the formula:—

$$Q = 3\cdot09 l H \sqrt{H}.$$

See Article 40 of Unwin's Hydraulics,

or if end contractions are to be taken into account, as would be necessary in the case of a narrow notch—

$$Q' = 3\cdot09 (l - 0\cdot1 n H) H^{\frac{3}{2}}.$$

I have already described to you the various methods of gauging the quantity of water yielded by wells and springs and, as a matter of fact, I have given you, in the table of the discharge from a rectangular weir, sufficient information to enable you to gauge quite a large stream, and from large streams it is very easy to carry our thoughts on to small rivers, and then on to large ones. By rivers, as I have explained before,

I do not refer to these drainage channels which run along the low land between two large rivers, but to the channels which carry large bodies of water, and which run along the high land between two drainage channels. The rivers of this country may be divided into two classes—perennial, or those that have water flowing in them all the year round, and annual, or those in which water only flows during a certain period of the year, the beds at other times being nearly, if not entirely, dry. As examples of the former, I may quote the Ganges and the Brahmaputra, while to illustrate the latter the Sone, the Mahanadi in Orissa, and the Phalgu in Gaya may be mentioned. Now in the case of large perennial rivers it would never be necessary to ascertain the quantity of water brought down by them even in the driest season; in the case of a perennial river of small dimensions it might be necessary to do so; and in that case the discharge might be ascertained by means of a rectangular notch or by a series of triangular notches in cases where it is a broad river with a flat slope. But with the annual rivers the circumstances are somewhat different: towards the ends of their courses there are generally quite large streams of water flowing over their sandy beds, which would afford more than ample supplies for the largest towns, but there are cases in which the water disappears entirely during the hot weather from the bed of the river, and then the only method of making use of the river as a source of supply is by sinking wells in the bed; for, although the water may have disappeared completely from the surface, it will generally be found a foot or two below. The river Phalgu at Gaya is an example of this state of affairs; during the hot weather the inhabitants on its banks have to procure water by excavating small holes in the sandy bed. In 1894 an experimental well was sunk in the bed in order to ascertain whether it would be possible to obtain sufficient water for the supply of the town of Gaya; the experiment was carried out nearly on the same lines I have already described to you as having been done at Patna, and it was found that a well only 3' 3" diameter yielded over 6,000 gallons per hour steadily for days and days together. Under these circumstances it will not be necessary for me to detail to you the various methods of gauging large rivers, such as by means of current-meters or velocity rods and floats; you will find these methods fully described in any standard work on hydraulics or water-works engineering.

As regards the measurement of *surface water from cultivated areas*, this is quite unnecessary if the water is only in drainage channels, because they are not perennial streams, and are only available for purposes of water-supply during the rainy season. If, however, the water is collected in tanks, it may be necessary for you to ascertain what quantity of the water collected would be available for drinking or other domestic purposes. You all, of course, understand how to find the cubical contents of a figure whose length, breadth and depth are known, but in the matter of water in a tank whose sides are not watertight the depth is an everchanging quantity, getting less during the dry weather and increasing during the rains. Although large quantities of surface water may fall into tanks, the depths of water in them are not affected to a very great degree by this surface water, at least not permanently, because the level of water in a tank is generally the same as that of the

surrounding subsoil water; and if the level of water in a tank is temporarily raised by an inrush of surface water, it will subside to its normal level as soon as the water can pass off into the subsoil; conversely when water is abstracted from a tank for drinking purposes or by evaporation, it is replenished from the subsoil water as in the case of a well. It is not therefore possible to say with any accuracy what quantity of water a tank will yield, but a calculation of its contents when the water is at its highest level, reduced by the quantity of water in the tank at its lowest level, will give the minimum yield, and this will probably be sufficient for your purposes.

If the tank that receives the surface water is watertight, that is to say, one that has masonry sides and floor, we shall have, in calculating its available contents, to make some allowance for evaporation. No formula, as far as I know, has been devised which will give accurately the amount of evaporation that may be expected at different temperatures with varying degrees of humidity and constantly changing velocities of the wind. We must therefore depend rather on actual observations, and in India even those are not as plentiful as they might be, or if they are, they have not been published, as far as I know. The following table taken from Molesworth's Pocket Book may be useful:—

*Loss by Evaporation only in feet.*

	October.	November.	December.	January.	February.	March.	April.	May.	Total of months.
Rajputana ... ..	.49	.35	.29	.29	.35	.55	.73	.81	3.86
Bombay ... ..	.65	.49	.37	.44	.34	.44	.69	.99	4.41
Nagpur ... ..	.50	.42	.37	.33	.32	.48	.76	.59	3.77

or an average of .0165 foot = .198 inch per day. No doubt you may come across small masonry tanks from which the water disappears at a much greater rate than this, although no water is being removed by means of pumps, etc.; the loss in this case will be due to percolation as well as evaporation, but the former is quite a preventible defect, and there should, in a well-constructed masonry tank, never be any loss from this cause.

The *subsoil water under towns and villages* can only be obtained from wells, and I have already explained to you how the yield of wells can be ascertained with a fair degree of accuracy.

Having discussed the sources of water-supply and the methods of ascertaining the quantity of water obtainable, we must now take up the question of the quantity of water required by human beings. I cannot do better, I think, than read you what Drs. Notter and Firth say on the subject in their work on *The Theory and Practice of Hygiene*:—

“For drinking purposes the amount varies with age, sex, weight, climate, and occupation, but it may be laid down as a rule that the total daily amount necessary is equal to about half an ounce for each pound weight of the body, or in other words, an adult takes in daily about 70 to 1,000 ounces ( $3\frac{1}{2}$  to 5 pints) of water for nutrition. Now, of this water, about one-fourth to one-third exists in the so-called solid food,

that is, in the meat, bread, etc., and the remainder is taken in some form of liquid. There are, however, wide ranges from the average. Women drink less than men; children drink, of course, absolutely less, but more in proportion to their bulk than adults.

“For the cooking of food a certain amount is required, only part of which is actually consumed with the food. This will generally not be less in the case of adults than three-quarters of a gallon daily. Taking all sexes and all ages together, we may lay down the minimum necessary for drinking and cooking purposes as 1 gallon per head per diem.

“Parkes measured the water expended in several cases: the following was the amount used by a man in the middle class, who may be taken as a fair type of a cleanly man belonging to a fairly clean household:—

	Gallons daily per one person.
Cooking ... ..	0·75
Fluids as drink (water, tea, coffee) ...	0·33
Ablution, including a daily sponge-bath, which took $2\frac{1}{2}$ to 3 gallons ...	5·00
Share of utensil and house-washing ...	3·00
Do. of clothes (laundry) washing, estimated	3·00
Total ...	<u>12·00</u>

“These results are tolerably accordant with actual experiments, if we remember that with a large household there is economy of water in washing utensils and clothes, and that the number of wives and children in a regiment is not great. In poor families who draw water from wells the amount has been found to vary from 2 to 4 gallons per head, but then there was certainly not perfect cleanliness.”

From the above extracts it will be seen that the quantity of water required for cooking and fluids as drink amounts to only 1 gallon. In Indian towns, where a filtered water-supply is not available, all personal ablution is done in the nearest river or tank, as is also the washing of clothes; a certain amount of water is required for utensil and house-washing, but probably not more than two gallons when the water has to be drawn from a well; so that the consumption of water per head in a town, that is not provided with a system of filtered water-supply, does not probably exceed three gallons. The number of towns in which a system of water-supply has been introduced is yearly increasing, and I am able to place before you the following table of the actual quantity of water supplied per head per day during the past three years:—

WATER-SUPPLY.

Statement showing Consumption of Water in gallons per head per day in some Indian Towns.

Town.	Province.	1895-96.	1896-97.	1897-98.	Average.	Town.	Province.	1895-96.	1896-97.	1897-98.	Average.
Adoni	...	4.6	4.0	5.0	4.5	Karachi	...	15.0	15.0	15.0	15.0
Agra	North-Western Provinces.	7.7	9.0	7.9	8.2	Kurnool	...	Not opened	4.2	7.6	5.9
Ahmedabad	...	12.1	14.1	15.9	14.0	Lucknow	North-Western Provinces.	2.3	3.9	3.1	3.1
Allahabad	North-Western Provinces.	7.9	9.1	8.1	8.4	Madura	...	6.9	7.0	6.7	6.9
Arrah	Bengal	Not opened	2.1*	2.1*	2.1	Meerut	North-Western Provinces.	Not opened	3.0	3.9	3.5
Benares	North-Western Provinces.	7.5	8.1	9.0	8.2	My m e n - singh.	...	3.9	3.9	4.1	4.0
Bhagalpur	Bengal	Not measured	10.6	10.6	10.6	Nagpur	Central Provinces	10.0	12.0	12.1	11.3
Burdwan	Do.	6.5	6.5	6.5	6.5	Naini Tal	North-Western Provinces.	Not measured	4.8	4.8	4.8
Cawnpore	North-Western Provinces.	7.3	8.0	8.1	7.8	Peshawar	...	8.0	7.5	7.5	7.7
Conjieveram	Madras	Not opened	5.9	6.2	6.0	Raipur	...	8.1	8.8	9.8	8.9
Dacca	Bengal	4.1*	4.1*	4.1*	4.1	Raj n a n d - gaon.	Central Provinces	5.4	5.9	5.5	5.6
Darjeeling	Do.	8.8*	8.8*	8.8*	8.8	Surat	...	8.0	8.0	8.0	8.0
Delhi	Punjab	Not measured.	4.5	4.8	4.6	Tanjore	...	6.6	8.3	11.5	8.8
Dhulia	Bombay	10.0	10.0	10.0	10.0	Trichinopoli	...	Not opened	10.5	10.5	10.5
Hinganghat	Central Provinces	9.0	9.0	9.0	9.0	Umballa	...	Ditto	4.4	4.7	4.5
Howrah	Bengal	Not measured	8.1	8.1	8.1	Average			...	...	7.4

\* These figures are doubtful, as there are no means of accurately measuring the water supplied.

The average daily supply in 31 towns scattered over India is thus 7.4 gallons per head, that is to say, taking only the ordinary mufassal towns. When, however, we come to the Presidency towns of Calcutta, Bombay, and Madras, we find that the total quantity of water supplied is from 30 to 50 gallons per head per day, but it is notorious that in these towns the waste of water is excessive; and, moreover, they are sewered towns, and water is required for flushing drains and privies. The quantity of water consumed in such towns, therefore, is no guide to the requirements of small towns and communities such as you may be called upon to deal with. The following statement gives the consumption in some of the principal towns in England:—

Town.	Gallons per head per day.	Town.	Gallons per head per day.
London (Grand Junction Water-works Company).	55½	Liverpool	31½
London (Chelsea Water-works Company).	47	Croydon	31
London (Southwark and Vauxhall Water-works Company).	45	Manchester	30
Brighton	43	Halifax	29
Plymouth	43	Swansea	28
Hull	43	Blackburn	25
London (average)	41	Bristol	23½
London (Lambeth Water-works Company).	40	Bolton	23½
London (West Middlesex Water-works Company).	39	Birmingham	23
London (New River Water-works Company).	35½	Huddersfield	23
Bradford	35	Burnley	23
Leeds	35	Oldham	22
London (East London Water-works Company).	34½	Cardiff	22
Preston	34	Sheffield	21¾
London (Kent Water-works Company).	33¾	Nottingham	19
		Birkenhead	18
		Leicester	18

“Engineering” of 16th September 1898.

The average consumption in the above towns works out to 27.92, and although these are all sewered towns and nearly all of them have water-closets, this is a very much smaller quantity than is used in

Calcutta, which although sewered has but few water-closets, there being only about 2,000 privies connected with the sewers.

I have now described to you, gentlemen, the sources from which water is obtainable, the steps to be taken to ascertain its quality, and the methods of finding out the quantity of water yielded from each of these sources. There still remains for consideration the questions of collection, purification, and distribution, and this part of my lectures I shall endeavour to make more interesting by laying before you and explaining designs of works that have been actually constructed.

### THE COLLECTION OF WATER.

It will be more convenient if we do not adhere any further to the list of waters classified according to their order of purity, because waters of varying degrees of purity may have to be collected in the same manner; for instance, subterranean or deep-well water, a very pure water, has to be collected in a well in the same way as a very impure subsoil water. I shall discuss the collection of water in the following order: (1) from springs, (2) from wells, (3) from tanks, and (4) from rivers.

Ordinarily speaking, when the water from springs, whether deep or shallow, is to be used as a source of drinking-water, all that is required to be done is to build a small covered masonry well or vat round it, and then if a pipe with a tap at the end of it is built through the wall, the water from the spring can be drawn off before it can get polluted by the dipping into it of dirty pots and pans. This arrangement will do as long as the spring delivers enough water to supply all wants during the hours of biggest demand, but it may so happen that although the total yield of the spring during the 24 hours may be even more than the day's demand, the rate per hour at which the water is discharged falls much below the maximum rate of demand, which is generally assumed to be half the daily supply delivered in four hours. It will then become necessary to build a somewhat larger reservoir round the spring and impound in it a whole day's supply of water; with this arrangement all the water that is not actually drawn off by the consumers will accumulate in the reservoir against the time of greatest demand. The figure below will give you an idea of the arrangement:—

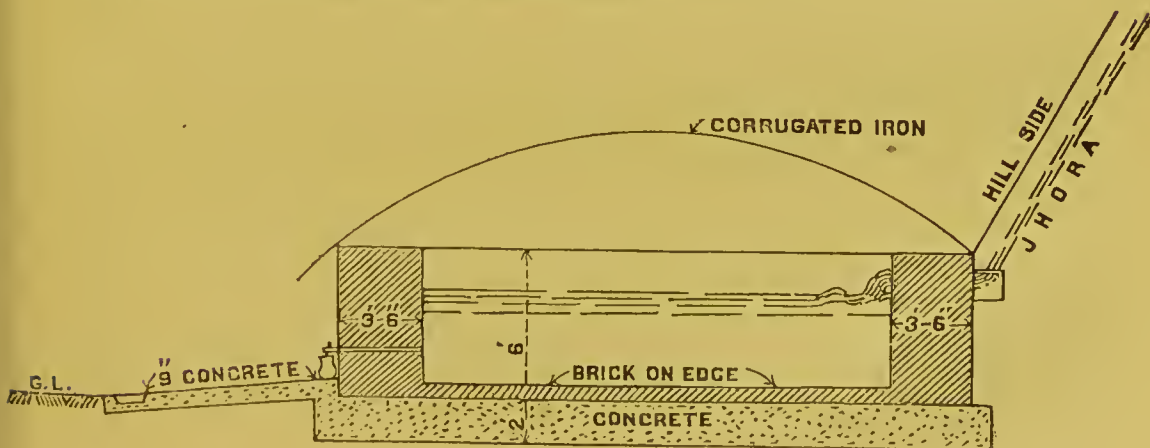

The walls of the reservoir should be built either of stone or brick set in the best hydraulic mortar; you will be able to decide the thickness of these walls from the lectures you have received on the stability of retaining walls. The floor should be of hydraulic concrete at least 9 inches thick, and if the depth of water exceeds 6 feet, I would advise a brick-on-edge course in cement over the concrete: it should be given a slight slope so as to facilitate the draining and cleaning out of the reservoir. Overflow and wash-out pipes must be provided. The whole reservoir should be covered in, and water should only be drawn off from it by taps fixed in the side-walls. It will add greatly to the appearance of the reservoir if a concrete or terraced floor is laid under the taps; this will prevent the ground getting muddy and sloppy from the splashing from the taps. This floor or platform should be given a good slope away from the reservoir, and should end in a small drain which will carry off all waste water.

Water collected in wells, whether deep or shallow, is the source of supply of the bulk of the population of the world, for it is by this means that we can tap, and obtain for our use, the great underground sea of subsoil water, and we can also by the additional aid of pumps draw on the subterranean reservoirs of water. In the case of the former, wells are an economical method of collection, but, unless due care is exercised, an exceedingly dangerous one; as regards the latter the very reverse is the case, for deep wells in subterranean water-bearing strata are exceedingly expensive to construct on account of their great depth, and the water, although it is of great purity, has generally to be raised by expensive pumping machinery. We need only, I think, confine ourselves to the consideration of wells which derive their supply from subsoil water, because the art of deep-well boring is a speciality and one which you are not likely to be called upon to exercise, and so I must refer you for further information on the subject to such books as Spon's *Practice of Sinking and Boring wells*, Tudsbery and Brightmore's *Principles of Water-works Engineering*.

Now the ordinary well of this country is usually constructed by excavating a circular hole rather bigger than the earthen rings with which it is lined; little consideration, except that of convenience, is given to the site that is chosen for the well; the hole is carried down to dry-weather water-level, or perhaps a foot below it; the earthen rings are then lowered into position, the earth filled in round the backs of them, but no mortar or cementing material is used for keeping the rings together. In some cases an earthenware top (*dhakna*) is fixed in position, but more often than not the top of the well is left flush with the ground surface. Now, I am not going to utterly condemn a well that is constructed in this way, for the simple reason that no amount of disapproval will ever stop their being made, for they suit the needs and pockets of the people, but what I would do is to try and suggest some inexpensive improvements which would possibly render the water in the well much safer and less liable to pollution. I am supposing that a well of this description is one to be made by a private individual, for I trust and hope that no municipality or other public body would ever be guilty of constructing a well with only earthen rings.



The choice of site therefore is limited ; in fact, I might almost say there is no choice in the matter at all ; we must therefore endeavour to improve the site we have. The first thing to do is to completely fill up any cesspool that is on the premises, and you must try and persuade your neighbours to do the same, so that the percolation of offensive matter from their cesspools may not pollute your well. Good materials for this purpose are cinders or broken brick, or the remains of masonry buildings, both of which are often procurable for the mere cost of cartage. You must then see that proper arrangements are made for preventing the urine and cook-room water soaking into the ground anywhere near the well. They must be removed to a distance, preferably in open masonry drains. If the ordinary black earthenware rings are used, they should be carefully plastered with lime mortar all round the back, so as to prevent the water percolating through the open joints ; if burnt clay segments such as are found in Bihar are used, they should be set in lime mortar, and all the joints carefully filled and pointed. The top ten feet of the well should be lined with brick masonry in lime mortar, one brick (10") thick. The object of all this careful lining of the well is to get all the water to come through the bottom, as it will be much purer, having had to pass through a greater depth of straining or filtering material. Every attempt should be made to prevent water coming through the lining or steining. The well above ground level should be finished off with a raised wall, about 2' 6" above ground level, and a sloping masonry platform all round the well, so that any water that may be spilt may be quickly carried away from the neighbourhood of the well. If the level of the water in the well never falls more than 20 feet below ground level during the driest months of the year, a small hand rotary pump might be added, and then the well could be entirely covered in by a brick dome.

Now, as regards wells constructed by public bodies, such as Municipal Commissioners or District Boards, these in my opinion should invariably be lined with masonry in lime mortar from top to bottom. They should be sunk at least five feet below the lowest known water level, and from water level to ground level the brickwork should be surrounded by about 12" of carefully puddled clay. The well, of course, from water level downwards will be sunk by excavating the interior with an iron excavator, but from water level upwards it can be built. The well should be finished off with a circular wall about 2' 6" high, round which should be constructed a good sloping concrete platform about 10 feet wide. This concrete platform should be constructed on a layer of carefully pugged clay not less than 12" thick. If the water level is less than 20 feet below the ground level during the driest season of the year, a small rotary pump should be fixed on the top of the well, which could then be entirely covered in by a brick dome. Should the water be deeper than 20 feet, arrangements should be provided for obtaining water from the well, so as to prevent the indiscriminate dipping of *lotahs*, buckets, etc., which may be very much polluted, and any of which might destroy the purity of the well. It is customary in this country to leave the tops of wells entirely uncovered, but I think the water would be much improved if light corrugated-iron, or even thatched, roofs were provided ; such an arrangement would give shade to the users, and it would to a certain



These simple rules will, I hope, be sufficient to guide you in selecting proper sites for wells, but it will be as well if you can obtain the advice and opinion of the local medical officer on the subject.

When the level of the sub-soil water is never more than 20 or 22 feet below ground level at the driest season of the year, a very convenient method of obtaining water is by what are known as tube-wells, and the water obtained from them is less liable to contamination than that from an ordinary open well. Wrought-iron tubes (the point being steel pointed and drilled with holes for a few inches) are driven into the earth by means of an annular weight, falling upon a clamp, which grips the tube near the ground, the tube itself forming the guide. The driving weight is raised by pulleys attached to a tripod and allowed to fall on the clamp until the tube penetrates the earth and the clamp reaches the ground. The clamp is then shifted, and the process repeated until the whole length is driven. Fresh tubes are connected and driven in this manner until water is reached, when a pump is screwed on to the tubes, and after a short pumping clear water is obtained. When tube-wells were first introduced it was supposed that any kind of common gas or other pipe would answer the purpose, but experience has shown that inferior tubing is very apt to crack during driving, or that the screw threads, by which the tubes are joined, strip and consequently prevent the tube being quite airtight. It is almost as easy to lift a tube-well out of the ground as to drive it by simply reversing the process of driving, and in the conglomerate soil of the plains this is of special use, for if water is not found in one place, it will often be found in another only a few feet off. After the tube has been driven and it has been ascertained that a plentiful supply of water is available, the soil round the tube should be removed, say, to a depth of a foot and a concrete platform constructed. This keeps the pump firm, and also prevents any dirty water from percolating down the sides of the tube. If the tube-well is for public use, a masonry reservoir to hold about 300 gallons should be constructed in front of the pump. It should be provided with a heavy sheet or cast-iron cover, which can be padlocked if necessary. At the opposite end to the pump there should be, close to the bottom of the reservoir, a tube with a plug, and above that a brass tap. The base of the reservoir should slope slightly towards the lower tube. The spout of the pump opens inside the reservoir, so that during pumping the water cannot be contaminated. The sloping bottom and lower tube permit the reservoir being cleared of any deposit. When water is required it is withdrawn by the tap. I will leave the question of the class of pump to be used for later consideration. In 1896 the Sanitary Board asked Municipalities and District Boards to report any experiences they may have had with tube-wells, and from the replies received it appeared that tube-wells had been tried by 16 out of 38 District Boards, and by 19 out of the 146 Municipalities in Bengal. In the Districts 78 wells had been sunk, of which 58 sunk in 10 districts were successful, and in the Municipalities only 13 were successful out of 40 sunk. In many cases the failures were due, not to the absence of water, but to the tubes cracking during

driving, and so ceasing to be airtight. I have already explained to you how very inferior in the scale of purity the subsoil water near towns and large villages is, and consequently I consider that tube-wells should only be used by District Boards and in places remote from large collections of houses and huts; they are, however, very useful in small villages, isolated houses, camps, etc.

A group or system of wells is very often used for the collection of water for large towns, and the water-supplies of Delhi, Lahore, and Umballa in the Punjab are instances of this; these are systems which I have had an opportunity of inspecting personally, but there are many other towns which have this system of collection. I have already described to you the experiment that has been made at Patna, and I hope it will not be very many years before this scheme of water-supply is taken up in earnest; Gaya also will eventually get its supply of water in a similar manner. Water-supplies obtained from wells are very economical, because the water is so pure that it can be pumped directly into the supply mains, and has not got to be lifted first into settling tanks, purified by passing through filters, and then pumped a second time into the distributing mains; the cost of one pair of engines and pumps, the settling tanks, filter beds, and clear-water reservoir is thereby avoided, and with only one set of pumps at work the annual maintenance charges are very materially reduced. I am bound to admit that the system of wells at Delhi has not been an unqualified success, and I think the reason is not far to seek. The line of wells has been sunk parallel to, and on the edge of, the river Jumna. Plate No. 2 shows the general arrangement and construction of the wells. Now, as they are parallel to the river, they must intercept all the subsoil water on its way to the river, and when the draught on the wells becomes, during the hours of pumping, greater than the subsoil water can supply, the river has to be indented on; during the rains the river contains a large amount of silt, and it is believed that this silt must have been drawn against and into the bank of the river between the river and the wells, and so has clogged it so heavily that no water can pass through it, or, at any rate, in such small quantities that it does not make up for the deficiencies of the subsoil water. At Lahore and Umballa the wells have been sunk in the old beds of rivers, and great care was taken to lay out the lines of wells at right angles to the direction of flow of the subsoil water. The yield of these wells has at all times been satisfactory. Plate No. 2 shows the design and general arrangement of the wells at Umballa, and I do not think they can be improved upon. The following description is taken from the Completion Report by Mr. C. E. Goument, ASSOC. M. INST. C. E., the Executive Engineer in charge:—

“The site of the wells is a tract of sandy waste about three-quarters of a mile from the Tangri *nala* and a quarter of a mile from the Tangra, a flood-spill channel of the Tangri. It is on the Umballa-Nahan Road, about half a mile from the village of Handesra and eight miles from Umballa city, in a north-easterly direction. The source of supply is a subsoil water basin between the two *nalas* above-mentioned, which have a large discharge of water in the monsoon

months, but are dry the rest of the year. An area of land 2,000 feet by 1,000 feet has been taken up all round the wells, and is strictly preserved. The wells are constructed of bricks in lime mortar and covered with concrete domes, which project 2' 3" above mean ground level. They are 7 feet internal diameter and pitched 60 feet apart centre to centre. This spacing was determined by the following considerations: First, the length of suction-pipe which could be effectively worked by the pumping engines. Second, the cone of exhaustion observed at water surface in an experimental well when it had been pumped down to the maximum depth fixed for pumping. As regards the latter, it might be noted that this cone, as observed in tests made about five months after the wells had been in continuous use, was found to be very much larger and more depressed under the same head than that observed in the preliminary experiments, which lasted a few days only. The estimate of the yield of the wells had been based on extensive experiments on trial wells by Mr. Campion, Executive Engineer, and Mr. Yeoman, Assistant Engineer. Both these sets of experiments were printed and are on record. It was assumed in the original project, from Mr. Campion's experiments, that 20 wells would give 300 gallons a minute under a pumping head of 7 feet below spring level. The actual yield of all 20 wells working together under this head has been found to be 195 gallons per minute.

"The wells are connected by a line of 9" cast-iron pipes laid parallel to the line of wells with 4" pipe connections to each well. These pipes are laid 3½ feet below normal spring level, and act as suction pipes for the pumps when these are at work, and collecting pipes for the gravitation main when the pumps are not working. As these pipes are laid under water in a treacherous sandy soil, they are provided with flexible joints. The main 9" pipes have Maclaren's rubber joints, and the joints of the 4" branches are ball and socket."

I have recently been informed by Mr. Campion that this system of obtaining water has worked perfectly in all its mechanical and physical arrangements, but owing to a severe fall in the spring level at the wells, due to the drought during the past two monsoons, there has been a deficiency in the supply of water.

We have now to consider the question of the collection of water in tanks. In England and America the word "tank" is understood to mean an artificial cistern or reservoir used for holding water or other liquids, and such cistern or reservoir is generally made of such materials as wood or iron, and its size is therefore to a certain extent limited. In India, however, the word "tank" includes not only the artificial cisterns made of wood or iron, but also excavations in the ground containing water, such as you may see in any town or village in those provinces, and the large lakes formed by throwing embankments across the mouths of valleys, a class of tank very common in the Madras Presidency, there being no less than 42,000 on the Government list alone. The majority of the tanks in Bengal have been excavated for the purpose of obtaining earth wherewith to raise the neighbouring ground for building sites; in the suburbs of Calcutta it is estimated that at least 20 per cent. of the whole area is occupied by tanks; in very low-lying places like Chittagong with its large Muhammadan population the earth

excavated from tanks is also used for making burial-grounds. In both these cases the subsoil and surface water flowing into the tanks is of a very foul description, but I regret to say that this does not prevent the tanks being used for the collection of water for drinking and washing purposes. Small tanks, I am afraid, are evils which we must put up with for many years to come, but their further construction should be discouraged in every possible manner, because I feel quite sure that they merely act as centres for the dissemination of water-borne diseases, such as cholera and typhoid. It is supposed by many that the construction of a tank confers a great benefit on the community, but in my opinion much more good would be done if the money that is now spent in excavating tanks were devoted either to completely filling up existing insanitary tanks or to improving those that are at present necessary for the water-supply of the locality. The improvements might consist of so raising the banks of the tank as to prevent the access of all surface water, or of providing small pumps and iron or masonry raised reservoirs in order that the low level tank might be completely enclosed, so as to prevent all access to it. In the former case there would be no diminution in the supply of water in the tank, as is commonly supposed, because the level of water in a tank is regulated entirely by that of the surrounding subsoil water, and unless the sides and bottom are made watertight by means of masonry or pugged clay, it does not matter how much surface water is discharged into the tank, for it will simply percolate out of the tank until the level of the water is reduced to that of the surrounding subsoil water. After a prolonged period of rainless weather such as we are subject to in this country, the first rush of surface water into a tank is of an extremely foul description, and so, if we can keep this out of a tank, we shall have accomplished some little purification. As I have already pointed out, the subsoil water near towns and villages occupies the lowest place in the scale of purity, but this is no reason why we should add to its impurity by allowing it to be further polluted and contaminated by foul surface water; and besides, if surface water is kept out of the tank and the slopes are carefully turfed, the water of the tank will remain clear throughout the rains and therefore more pleasant to look at and drink.

A year or so ago a proposal was received from a town, whose name I need not mention, to fill up some of the tanks, used for drinking purposes, by passing water from the river, while it was in flood, down the open side-drains of the bazaars and streets and so into the tank. The proposal could not be accepted for one minute because it simply meant the washing into the tank of several days, possibly weeks', sweepings and filth from the streets.

As regards the provision of a pump and small iron or masonry reservoirs, all that has to be done is to ascertain roughly how many people use the water from the tank, and then, allowing about two gallons per head, you will be able to calculate the size of the reservoir necessary to give, say, two or three days' supply in case the pump requires to be repaired. It is better to divide your reservoir into two compartments, so that one can be kept in use while the other is being cleaned. The ordinary 400-gallon iron tank has been found

very useful for this purpose, and one, you will see, will contain sufficient water for 200 people for one day; but it is better to provide them in pairs for the same reason that a masonry reservoir should be built with two compartments. The bottoms of these reservoirs need not be more than one foot above the ground. The taps for drawing off the water should be fixed one foot above the bottoms of the reservoirs or two feet above the ground; this will give a foot depth of the reservoir in which some of the impurities in the water may be deposited. Wash-out taps should be fixed in the bottoms, so that all the water may be drawn off and the inside of the reservoir cleaned and either painted with a good silicate or oxide of iron paint at intervals, or even whitewashed. The reservoir should be surrounded by a good sloping concrete platform with a drain such as I have already described for wells. The rest of the installation consists of the pump and the iron suction pipe through which the water is drawn up from the tank and discharged into the reservoir; the points in these which require attention will be discussed later on.

The larger tanks or lakes are, as I have said, formed by throwing a dam of masonry or earth across a valley, and thereby impounding the rainfall that flows off the surrounding hills. The majority of the tanks in Madras, and also in Mysore, are used for irrigation purposes only, but there are several towns in India in which this method of collection has been utilized, for instance, Bombay, Jubbulpore, and Nagpore. Proposals have been submitted for supplying the town of Chittagong in this manner, but funds are not forthcoming, and so nothing is being done at present. The water is impounded at a very high level, and consequently can be easily distributed by gravitation. The water is withdrawn as a rule from the tank through a vertical pipe enclosed in a large masonry tower built preferably at the side of the tank, so that the discharge pipe may pass round the end of the dam instead of underneath it; where the dam is not very high (over 20 feet) and the discharge of water not great, a syphon laid over the top of the dam is a very convenient method of drawing off the water. An overflow weir must also be provided for the discharge of rain falling when the tank is quite full.

The questions involved in the designing of projects for the collection of water in large tanks or lakes are too intricate and complicated for me to describe to you in this short course of lectures, and all that I can do is to give you a list of books in which you will find the subjects of available rainfall and the construction of dams and their accessories fully dealt with. Should you ever be called on to collect information for or to design such works, you will find in the following books all the latest information and the results of the most recent researches:—

- (1) A Practical Treatise on Water-supply Engineering, by J. T. Fanning.
- (2) The Principles of Water-works Engineering, by Tudsbery and Brightmore.
- (3) The Proceedings of the Institute of Civil Engineers, volumes CIX, CXIII, CXV, CXIX, CXXVIII, CXXX, CXXXII.
- (4) A Manual of Hygiene, Sanitation and Sanitary Engineering, by J. A. Jones.

From the perusal of these works you will learn that the following points require the most careful attention in the preliminary investigations for selecting a suitable drainage area and reservoir site:—

- (a) The annual rainfall over as long a series of years as possible.
- (b) Careful and frequent measurements of the quantity of water that flows during the rainy season down the streams at the bottoms of the valleys. By comparing these with the recorded rainfall an idea of the available rainfall may be obtained.
- (c) A careful survey of the proposed site with contours at every 2 or 3 feet.
- (d) Borings and trial pits, not only over the site of the proposed dam, but also in the hills forming the sides of the proposed reservoir or tank.

We now come to the collection of water from rivers; and as the level of the water in them is normally below that of the surrounding country, some means must be adopted for raising the water up to such a height as will enable it to be purified in the manner to be described hereafter. As long as water is to be obtained from a river in which there is water flowing all the year round no enquiries need be made as to the quantity of water in the river during the driest periods of the year. In European countries, where the rivers are small and the water-supplies are large and the rights of riparian owners, etc., have to be guarded, the quantity of water that can be taken from a river for water-supply purposes has to be very carefully studied and thought out, but in this country the rivers are as a rule so large and the water-supplies are comparatively so small that considerations of the quantity of water in the river need not be entered into, provided, as I have said, there is flowing water in the river all the year round. We may have to deal with rivers like the Phalgu at Gaya, which disappears beneath its bed during the hottest months of the year, but I have explained to you how this water may be made use of for water-supply purposes by sinking wells.

I have already laid before you the considerations that must guide you in the selection of the point at which the water is to be withdrawn from the river, namely, that the intake should never be on the downstream side of the town or in the middle of the river face, and that there must be no *ghats* of any description whatever above the intake. To these points must be added another that, if possible, the intake should be on the deep water side of the river, for otherwise a *char* may form in front of the intake and give considerable trouble, if it does not cut off the water-supply altogether, during the dry months of the year.

If the water in a river is always practically at the same level and is not, say, more than 10 or 12 feet below ground level, as would be the case if the river were dammed up by a weir or anicut, a very good way is to excavate a short open channel leading from the river to the engine-house. This serves two good purposes. A good deal of the silt that is brought down by the river water during the flood season will be deposited in this channel, and the length of the suction pipe will be reduced to a minimum. This is the method that has been adopted at



Burdwan, and I believe it has never given the slightest trouble as far as the supply of water is concerned. The cutting is 75 feet long at water surface, and at the end of it a horse-shoe well has been provided, into which the water passes over weir boards, so that only the surface water is taken. The suction pipe from the pumps dips into this well. In spite of these precautions, however, the filtered water contains an impalpable silt which gives it rather an unpleasant milky appearance during the rains; during the past two or three flood seasons a "bund" made of broken bricks and cinders has been thrown across the mouth of the cutting, and all the water has to pass through what is practically a very coarse vertical filter, and this has had the effect of considerably improving its appearance. With a river that has a great range between high flood and lowest water level this system is not quite so suitable on account of the great depth, and therefore the great width of the cutting, and the horse-shoe well would have to be a somewhat massive structure in order to withstand the pressure of earth on the back. A modification of this system has been adopted at Lucknow and Cawnpore, where a structure corresponding to the horse-shoe well has been built on the river face; being on the river face the foundations had to be built on wells, so as to prevent the structure being undermined by the current, and wing walls, also founded on wells, had to be provided. These structures, therefore, are very massive, and consequently very expensive. At Allahabad and Bhagalpur the water gravitates from the river through an iron pipe laid in a tunnel, or culvert, into a well under the engine-house. As long as there is deep water at the mouth of the supply pipe this system works well, but at Bhagalpur we are now having considerable trouble, because a large *char* has formed over the mouth of the pipe, and it has now become necessary to redesign the whole intake. While mentioning Bhagalpur I must bring to your notice that this is a case in which the intake has been located in what I consider to be an insanitary position; it is just below the town, and flowing past it is all the surface drainage water from the most thickly populated localities; and further not 200 yards above the mouth of the pipe there is a bathing *ghat* largely resorted to by pilgrims, and about a quarter of a mile above it is a *ghat* much frequented by country boats. There is no good site, certainly for an intake, on the upstream side of the town, but in that case I should have felt inclined to go at least a mile below the present site, where the large body of water in the Ganges would have been able to purify the drainage water before it got to the intake.

At Arrah, Dacca, Howrah, and Mymensingh the pipe from the pumps communicates direct with the river and is what is called a suction-pipe, and this is the most satisfactory form of intake, provided the length is not too great. At Arrah the pipe is simply laid up the face and along the top of the river bank, but a traveller is provided, so that the length of the pipe on the river face can be shortened or lengthened according to the height of the water in the river. When the pipe reaches the engine-house it dips down into a well in which the pumps are situated; this is an exceedingly bad arrangement, because if you have once succeeded in raising your water no good can be done by letting it fall down to a lower level; and, moreover, unless an air-valve is provided and care taken to see that it is always kept in working order

air will accumulate at the highest point of the pipe and interfere with the flow of water. At Dacca and Mymensingh the suction pipes are carried on wooden jetties, and they have never given any trouble. Dacca is another instance of a bad selection of site for the intake; it is practically in the middle of the town, and crowds of boats are allowed to moor within 100 feet of the pipe, and to make matters worse it was not placed on the deep-water side of the river, and now a *char* has formed right across the intake, and money will have to be spent in remodelling it. At Howrah the suction pipe is carried on a screw-pile jetty, and then passes into the engine-house in a brick masonry tunnel or culvert, so that it is practicable to get at the pipe at any part of its length. The total length of the suction pipe is 277 feet. A novel departure has been made at Howrah, in that the suction pipe is made of mild steel and rivetted like a boiler throughout its length, so that it is practically one long pipe with no joints to let in air; ordinary suction pipes are usually of cast-iron flanged pipes in 9' or 12' lengths, and these pipes are liable to leak at the joints, unless the latter are very carefully made. Plate No. 3 shows the design of the Howrah intake.

At Berhampore, the water-works of which town are now under construction, it has been found necessary, owing to the pumps having to be placed behind the flood embankment, to have a suction pipe, nearly 900 feet long; but if the joints of the pipe are all carefully made, there is no reason, as far as I can see, why this pipe should give any trouble; for the greater part of its length it is laid in a masonry tunnel or culvert, so that it will always be possible to examine the pipe at all states of the river.

I must now explain to you the principles on which suction pipes are designed. It is usual to arrange the works on the basis that pumping shall go on for 10 hours out of the 24, and you will therefore be able to calculate the quantity of water required in gallons per hour or cubic feet per second. The velocity of water in the pipe should never be less than 2 feet per second on account of the large quantity of silt and mud in the water during the flood season, and on the other hand, too high a velocity is objectionable on account of the momentum of a comparatively long column of water. From these data you will be able to fix the diameter of the pipe. It is hardly necessary to provide a foot-valve to retain water in the pipe while the engines are not working, because a patent ejector has been invented which, by the expenditure of a little steam, soon charges the pipe. All suction pipes should be provided with a good-sized air-vessel, fixed as close to the pumps as possible; the function of this air-vessel is to take up any shock that may be due to the reciprocating action of the pump valves and prevent their being injured. The air-vessel obtains its supply of air from the water passing through the suction pipe, and to prevent too great an accumulation of air a snifting-valve should be provided. I should point out that the air-vessels on suction pipes are very often called vacuum-vessels, because they abstract the air from the water. Suction pipes should rise continuously from the water level to the pump-valves, for the reasons given in the previous page in the case of the Arrah suction-pipe.

The question of how high water can be raised in suction pipes will be left, more appropriately I think, to stand over until I come to discuss the methods of raising water by means of pumps because on it depends the disposition of the pump-valves.

### THE PURIFICATION OF WATER.

You will have gathered from these lectures that most of the water that is available for water-supplies in India is more or less impure, and steps have to be taken to free it of its objectionable matter, whether in suspension or in solution. Impurities in suspension can mostly be seen with the naked eye, and they are by far the easier to deal with; those in solution, however, can only be discovered by means of chemical and biological analyses, and they are not nearly as difficult to find as they are to get rid of. However, Nature comes to our aid, and we are able to clarify water by sedimentation, the force of gravity coming into play and causing the particles whose specific gravity is greater than that of the water to gradually settle down to the lower depths; and by filtration through sand, which not only strains out any grosser particles which are too light to be influenced by gravity, but also acts to a certain extent chemically by bringing films of air into contact with the noxious organic matters in the water, and biologically by the filtering media becoming the breeding ground of the beneficent micro-organisms which destroy the disease-producing germs contained in the water. I do not propose ~~to~~ such a short course of lectures to describe to you the various mechanical and chemical devices that have been invented from time to time for the purification of water, because as a rule their employment means a heavy expenditure for machinery, apparatus, and chemicals, which the incomes of local bodies even in Europe, and much less in this country, cannot be burdened with; all that I shall do will be to bring to your notice the simplest and cheapest methods—those that you may be called upon to devise and look after, whatever branch of the profession you may take up. In my opinion such mechanical and chemical processes are only suitable for dealing with the water-supplies of large institutions, such as hospitals, jails, barracks, colleges, etc., where they can be carefully supervised and looked after daily and hourly. The only exception that I am bound to make is in the matter of the purification of water in wells, which is below the surface of the ground and away from the influence of sun-light and air, although there is no doubt that sedimentation has a great deal to do with the purification of water even in wells. We all know that, as a rule, as long as there is a good depth of water in a well the water drawn from it will be suitable for drinking, and it is only during the hot, dry weather, when the water in the wells is getting lower and lower every day and very near to the bottom, that we hear of outbreaks of cholera. The reason of this, to my mind, is that the disease-producing germs have gradually sunk by the action of gravity, and have all become collected in the lower depths of the wells; and it is the same thing to a certain extent in tanks, the water at the bottom is always the most impure. I dare say many of you have heard that lime is a good thing to use to purify the water of wells: some of you perhaps have actually seen it

used. If quick-lime is used it no doubt acts chemically on the water, but in a manner that we do not exactly require for purification purposes, because it actually takes up oxygen from the water in order to become calcium hydrate, whereas for real purification oxygen should be added to the water in order to oxidize the organic matter that may be contained in it, and which is deleterious to health. When quick-lime is added to water it causes a great rise in temperature, and the water often boils, which no doubt will destroy nearly all microbes and germs, and thus, what is called, sterilize the water; but quick-lime is only obtainable where lime is being manufactured, and as you know it slakes by exposure to air, consequently there are very few towns or villages in Bengal where this method of purification could be used. If slaked lime is used it simply clarifies the water by its particles gradually sinking down through the water and dragging down with them the filmy mass of bacteria. To my mind clay or brick-dust would have just as great a purifying power as slaked lime, and these materials are of course much cheaper. By far the best thing to use for wells, and probably every bit as cheap as lime, is permanganate of potash (the principal ingredient of Condy's fluid), a substance which, as you have learnt from your chemistry, is ever ready to part with some of its oxygen; now, oxygen has the effect of rendering the beneficent germs more active and more ready to attack and demolish the disease-producing germs, and, combining with organic matter, oxidizes it and renders it innocuous. We thus see, and know from actual experiment, that permanganate of potash has a much greater purifying effect on water than lime or any other substance. I therefore commend it to your most careful consideration. As soon as a well in your charge ceases to have less than six feet of water in it, calculate out the quantity of water it contains and obtain permanganate at the rate of 10 ozs. per 1,000 gallons; the cost in Calcutta is about a rupee per pound. If the water is very impure, you may require more. Then as to the method of applying—throw into the well about 3 or 4 ozs. per 1,000 gallons and then agitate the water by drawing up buckets of water and then pouring it back again; keep on doing this until the water assumes a pink tint and then stop for five minutes; if the tint disappears, add an ounce or so more and then allow to rest for five or six hours. If the permanganate or Condy's fluid is added at night, the water should be quite purified and ready for drinking by the following morning.

The permanganate cure can also be applied of course to tanks, but I am afraid the cost in most cases will be prohibitive, and so we must trust more to the action of the air on the exposed surface of the water. Here again Nature steps in to our assistance, not only with the unconquerable force of gravity, but by causing the winds to blow and ruffle the surface of the water, so that every little ripple enfolds in its clutches a particle of air which is made to part with some of its oxygen for the purification of the water. If it were not for this action of the wind on the surface of water, thus producing waves and ripples, there is no doubt that every large body of water, and even the sea itself, would become so utterly obnoxious and impure that life on this earth would be quite impossible, and if Nature assists us in this way it is our duty to try and help ourselves by not willingly or deliberately polluting

the water provided for us so bountifully. I have already explained to you how every effort should be made to keep the foul surface water out of tanks, but you must protect your tanks from individual pollution by fencing them in and absolutely forbidding any human being to go near them. It has always been the policy of the Sanitary Department to endeavour to get municipalities and other local bodies to reserve tanks for drinking purposes only, but it almost seems a hopeless endeavour when people are so careless and thoughtless that even the very custodian of a tank has been found washing his own clothes in it! But sanitary officers must not be deterred by incidents of this nature: patience and perseverance must ever be their watchwords. Therefore, I repeat, the best method which we can adopt for the purification of the water collected in tanks is to prevent all access from the outside and obtain the water therefrom by raising it by means of a pump into small tanks or reservoirs accessible to the general public. At Faridpur the Municipal Commissioners have not only done this, but they have also constructed a small installation of sand-filters, which, I understand, have been much appreciated.

When a water-supply is derived from a river special arrangements have to be made for ridding the water of the large amount of earthy matter in suspension that is brought down in the flood season; this is not a state of affairs peculiar to India by any means, and large subsidence reservoirs are provided in all European and American water-works deriving their supplies of water from such a source, but these subsidence reservoirs have, as a rule, an additional use, in that they also serve as storage reservoirs against a time of drought, when the discharge of the rivers becomes very small and hardly sufficient to keep up the supply of "compensation water," which is due to riparian proprietors for any possible damage to, or interference with, their interests caused by the abstraction of water. In India, with its huge everflowing rivers, the question of storage has seldom, if ever, to be considered, and consequently we only have to construct subsidence reservoirs, or, as they are called in this country, settling-tanks, of such a size as will give sufficient time for the water to be cleared of its silt before it is drawn off into the filter-beds. As a rule, a settlement of 24 hours is found quite sufficient, although in the case of Burdwan, which draws its supply from the Banka river, a settlement of even 24 days is insufficient to clarify the water, but this is due to the fact that the Banka is rather a drainage channel than a river. If arrangements can be made, as at Cawnpore and Lucknow, whereby only the surface water of the river is drawn upon, the time of settlement can be reduced to a minimum, but usually the water is practically drawn from the bottom of a river, and consequently it contains much more silt than if it had been drawn from the surface. At the recently constructed works at Howrah four settling-tanks have been provided for a daily supply of 1,300,000 gallons. The effective contents of each tank is 1,578,670 gallons, and consequently the water can be quiescent in them for at least 48 hours. At Berhampore, where the river water is less laden with silt, and where the water will not be taken from the lowest depths of the river, only 24 hours' settlement has been provided by constructing three tanks, that is to say, one being filled, one quiescent, and one discharging water on to the filter beds. Plato No. 4 shows

the general arrangement of the settling-tanks, with the details of the weir over which the water is discharged into the tanks, and the outlet with its floating pipe. The daily supply for Berhampore is 200,000 gallons, but each of these tanks will contain 229,414 gallons, so that it will never be necessary to draw off the bottom two feet of water, which, as I have shown in the case of tanks and wells, contains the most impure water. The settling-tanks at Howrah were simply made with earthen banks and floors similar to those of the Calcutta water-works at Pulta, but they have given so much trouble from leakage and loss of water by percolation through the floors that it was decided to line the tanks at Berhampore with masonry. Six inches of concrete has therefore been laid over the floor, and the inner slopes of the banks have been covered with 3 inches of brick *khoa* rammed into clay puddle, on top of which brick-on-edge pointed with lime mortar was laid; the brick-on-edge on the slopes was laid dry and only pointed with lime mortar; so that if any settlement occurred in the banks, all that would be required would be a little fresh pointing. This method of lining the slopes of settling tanks has been found most effectual in the water-works of the North-Western Provinces.

The water from the river is pumped up into a masonry trough, from which it descends in a thin stream 1 to 2 inches thick over a series of steps into the settling tank; by this method of cascade discharge the water gets very thoroughly aerated. You will be able to calculate the required length of such a weir from the formula for broad-crested weirs that I have already given you.

The water is drawn off from the settling-tanks on to the filters through a pipe so arranged that it can revolve about its base, and by providing a float the inlet mouth of the pipe is always kept near the surface of the water, and so only the clearest water is drawn off. A small jetty has been provided, on the end of which a hand-winch is fixed (not shown in the drawing), so that the pipe may be drawn up above the surface of the water when no water is required to be taken from the settling-tank. The outlet pipe is also provided with a sluice, but this may always be kept open and only used in case the floating-pipe gets out of order. A second outlet pipe should always be provided so that the bottom two feet of water in the tank may be periodically drawn off; this is generally called the sludge-outlet pipe.

I have hitherto only described to you what is known as the intermittent form of settling-tank, which, as you all have seen, is alternately filled and emptied, the clarification of the water being principally due to the period of absolute rest when there is neither inflow nor outflow. An alternative form is the constant settling-tank, in which water is constantly flowing in and out of the tank, the sedimentation being due to the extremely low velocity with which the water passes through the tank. It is claimed for this class of tank that the surface of the water need never be any great height above the full supply level in the filter-beds, and that consequently the lift on the unfiltered water pumps will be reduced; and further that the cost of construction is much less than that of intermittent settling-tanks. The former of these contentions is undoubtedly correct; but in order to get the necessarily small velocity the tanks must either cover a very large area of ground, if they are to be kept above the influence of the subsoil water, or they must be

practically low-level tanks with a considerable portion of their depth below ground level. As regards the less cost of construction, I am very doubtful, for I find that at Meerut the cost of three constant system settling-tanks has been Rs. 25,000, or Rs. 8,333 per tank, whereas at Howrah, where the quantity of water to be clarified is about the same, four tanks have cost Rs. 30,000, or Rs. 7,500 each. I must admit, however, that the Howrah tanks are not lined with masonry as those at Meerut are. Again, the water-supply of Meerut is obtained from the Ganges canal, and I can hardly believe that the quantity of silt in a canal at a point 80 miles from its head works can compare with the quantity in the river Hooghly or any of the other rivers of Bengal. I have therefore very great doubt whether, for water that is very heavily laden with silt, the constant system of settling-tanks is suitable or even more economical. Plate No. 5 shows the design of the settling-tanks recently constructed at Meerut.

To give you some idea of the effect of storage or settlement on water, I have compiled the following table from Appendix B of the Twenty-sixth Annual Report of the Local Government Board, this appendix being Sir E. Frankland's report on his bacterioscopic examination of the London water-supplies during the year 1896-97:—

*Microbe determinations in East London Company's water.*

MONTH.	River water before storage.	River water after storage for 15 days.	MONTH.	River water before storage.	River water after storage for 15 days.		
January	...	6,720	3,140	July	...	2,680	1,520
February	...	7,880	1,600	August	...	6,020	2,140
March	...	20,640	1,460	September	...	32,000	2,160
April	..	Lost	Lost	October	...	12,200	1,460
May	...	8,180	1,180	November	...	10,880	3,200
June	...	11,720	2,340	December	...	13,420	3,056

The average reduction in the number of microbes was therefore 83 per cent.; but although there had been this great reduction, the water after storage was by no means considered fit to drink, and was submitted, as usual, to filtration through sand. When I come to explain to you what the standard of potable water from a bacteria point of view is, you will understand better why it is that water even after 15 days' storage is by no means a pure water.

I now come to what I regard as one of the most important duties of engineers and others in charge of water-supplies—I mean the purification of water by means of filtration. Before, however, describing to you the means by which filtration is carried out, I think it will impress the matter more on your minds if I explain to you why it is so necessary. The following extract is taken from the Appendix to the Army Medical Report for 1892:—

*"Filtration of Potable Waters.*—In connection with an enquiry into the causes of cholera at Hamburg, Professor R. Koch has published

a paper on Water Filtration and Cholera, which is, perhaps, one of the most interesting monographs that has appeared during the year. Cholera broke out in the three towns of Hamburg, Altona, and Wandsbeck, which are contiguous to each other, and really form a single community, and do not differ except in so far as each has a separate and a different water-supply. Wandsbeck obtains filtered water from a lake which is hardly at all exposed to contamination with foecal matter; Hamburg obtains its water in an unfiltered condition from the Elbe, above the town, and Altona obtains filtered water from the Elbe, below the town. Hamburg was notoriously badly visited by cholera, whereas Wandsbeck and Altona, if one excepts the cases brought thither from Hamburg, were nearly quite free from the disease. The conditions of the cholera epidemic along the boundary between Hamburg and Altona were also remarkable. On both sides of the boundary the conditions of soil, buildings, sewerage, population, everything of importance in this respect, were the same, and yet cholera in Hamburg went right up to the boundary in Altona and then stopped. The cholera not only marked the political boundary, but even the boundary of the water-supply between the two towns. In two great populations nearly all the factors are the same—one only is different, and that the water-supply. The population supplied with unfiltered water from the Elbe is seriously visited by cholera; the population supplied with filtered water is only visited by the disease to a very small extent. The difference is all the more important, as the water of Hamburg is taken from a place where the Elbe is relatively but little contaminated; whereas Altona resorts to the water of the Elbe after it has received all the liquid and foecal refuse of 800,000 people. Under these conditions there is no other explanation for the scientific thinker but that the difference in the increase of the cholera on these two populations was governed by the differences in the water-supply, and that Altona was protected against the cholera by the filtration of the water of the Elbe.

“Professor Koch, after briefly reviewing the various theories advanced as to the probable causes of the outbreak, enters fully into the questions of filtration. The problem, he says, of filtration is to purify water from the matter held in suspension. Matter which has been dissolved passes through the filter with hardly any or no perceptible change. He attributes little importance to the chemical examination, as this inquiry deals only with the dissolved impurities.

“The real filtration, where sand is used as a filtering medium, does not take place in the sand, but by a deposit from the still unpurified water a layer of mud is formed on the top of the sand, and this layer of mud which is over the sand is the real filter which retains the suspended constituents from the water. This has been very clearly stated in the *Report of the Royal Commission on the Metropolitan Water-supply* as follows:—

“The action of a filter-bed appears to be partly mechanical, partly vital; but the mechanical action which is confined, or almost confined, to the holding back of the comparatively grosser substances suspended in the water, and which was supposed until recently to be the only operation in a filter, is now held to be of far less importance



than the vital action, which depends on the activities of the gelatinous layer of living matter gradually deposited on its surface. A new filter, composed of perfectly purified sand, has little or no effect in producing either chemical or bacteriological purification, but in the course of use a layer charged with living microbes is deposited upon the surface, and it is by these organisms, which constantly increase in number, and also penetrate the sand to a slight distance, that both the nitrification of organic matter and the arrest of other microbes is effected.

“Thus the longer a filter has been in use the more efficient it becomes, provided, of course, that the surface layer has not acquired such density as to interfere with the passage of the water; and consequently the recommendation which was commonly given in former times, that a filter bed should be cleansed as often as possible, appears to have been a mistake; cleaning by which the efficient superficial membrane is removed should only be carried out when the filter becomes unduly blocked.

“The sand layer should never be allowed to get below a certain thickness—about 30 centimetres (12 inches), and it is also necessary that the rate of flow through the layer should be a fixed one—about 100 millimetres (3.95 inches) in an hour.”

“If a filter works satisfactorily in every respect, there will be found, as experience shows, less than 100 germs capable of development in 1 cubic centimetre of filtered water, and this is independent of the amount of bacteria contained in the natural water, whether such amount should be 100,000 or only a few hundred in a cubic centimetre. But the slightest disturbances in the process of filtration, for instance, the quickening of the pace of filtration to over 100 millimetres per hour, disturbances of the surface mud, covering, etc., tend as a consequence to an immediate increase of germs in the filtered water. Even the very best filtration processes are not sufficient to keep back all mixed organisms, and, according to all appearances, we have with the present processes reached the limits of that which is practicable. Dr. Koch then shows that the epidemic of cholera at Altona affords ample proof that we may be satisfied in practice with these results.”

The dire results of the non-filtration, or even the improper filtration, have been brought to light in numerous instances, but the experiences of the inhabitants of Hamburg, Altona, and Wandsbeck, are, I think, quite sufficient to show you how important and really necessary the filtration of potable water-supplies is. You will remember, I have no doubt, that I told you that filtration through sand was not only a mechanical, but also a chemical, action, but you have now heard that Professor Koch says that the problem of filtration is to purify water from the matter held in suspension, and that matter which has been dissolved passes through the filter with hardly any or no perceptible change. In defence, therefore, of what I have told you I must refer to the classic experiments on water filtration carried out by the State Board of Health of Massachusetts. The experimental filter consisted of sand of varying degrees of fineness, and held about 28 gallons of water; the experiment was continued for a whole year, and the weekly chemical analyses showed that “the sum of ammonias of the filtered water for the first six months was 63 per cent. of those of the unfiltered water, and in

the last six months was 69 per cent. of those of the unfiltered water. The ammonia of the filtered water has for the year averaged 0.0010 parts per 100,000, or two-thirds of that of the unfiltered; and the albuminoid ammonia has averaged 0.0086 parts, which is also two-thirds of that of the unfiltered water.

"The quantity of water filtered by this tank (20" diameter) in the year has been about 15,000 gallons, or the equivalent of 300,000,000 gallons upon an acre; and it appears as if it would continue, with the same treatment, removing about one-half of the colour and about one-third of the ammonias, as it has done during the past six months.

"To test the effect of exposing the water to more air while passing through the sand, the quantity of water was decreased to one-half a million gallons per acre, applied on six days in the week. This quantity was continued for a month with the result that the purification was much more complete. The colour was reduced to one-third; the free ammonia to 30 per cent., and the albuminoid ammonia to 44 per cent. of that of the applied water. The nitrates were 22 per cent. more than these of the applied water."

I submit, therefore, that the process of filtration through sand is not only a mechanical, but also a chemical, one. I shall have to refer to the improved results obtained by exposing the water to more air while passing through the sand when explaining to you the rules under which I consider filtration should be conducted.

A filter-bed consists of a watertight tank or reservoir containing a number of layers of the filtering material, with arrangements for admitting water on to the surface of the top layer, and for drawing it off after it has passed through the filtering material. The walls should be of solid masonry, of a thickness that can safely withstand the pressure of the earth backing and of the water in the filter when either is removed, because in this country the earth backing is so liable to shrink away from the masonry that cracks may be set up near the footings through which the water from inside or outside can percolate. The floor should be of brick-on-edge in good hydraulic mortar or Portland cement over 9 inches or 12 inches of concrete. Running down the centre of the filter bed a main drain should be constructed not less than 12 inches square towards which the floor on either side should slope. On the floor at right angles to the main drain rows of bricks, either on edge or flat, should be laid, so as to form passages for the water, which has descended through the sand, to run off into the main drain. Those passages should be covered over with bricks laid flat and close together. The main drain is most conveniently covered over with slabs of stone. Many engineers have advocated the making of the main drain impervious to water from above, but this has one drawback in this country, and that is that the main drain cannot be thoroughly cleaned when the filter is run dry, and I have seen main drains one mass of water weeds and green slime, which look most objectionable, and moreover interfere with the purity of the water. The real filtering material is the fine sand; but in order to prevent this being washed away by the passage of water through it, it is necessary to interpose some layers of materials of varying degrees of coarseness between the bottom of the fine sand and the underdrains, so as to

serve practically as a platform on which the fine sand rests. Three or four inches of pebbles and three to six inches of the coarsest sand obtainable serve this purpose very well.

Now, as regards the fineness of the sand in filter beds, I think I cannot do better than again give you an extract from Sir E. Frankland's report on the London water-supplies:—

“I have also added a table intended to show the effect of the degree of fineness of sand upon bacterial filtration. In the third column of this table the size of the grains of sand is indicated by the percentage which will pass through a copper gauze sieve of 1,600 meshes to the square inch, the maximum diameter of grains capable of passing this sieve being just under 0·4 millimetre ( $\frac{1}{25}$  inch).

*Degree of fineness of sand.*

COMPANY.				Thickness of sand.	Percentage of sand of less than 0·4 m.m. diameter.	Percentage of organisms left in.
THAMES.						
Chelsea	...	...	...	4·0 feet	26·10	6·0
West Middlesex	...	...	...	2·75 „	78·19	2·5
Grand Junction	...	...	...	2·25 „	28·70	8·9
LEE.						
New River	...	...	...	1·8 „	60·26	2·2
East London	...	...	...	2·0 „	33·12	3·1

“Neglecting the results obtained in June, which were altogether abnormal, the comparison made in the above table strikingly exhibits the enormous advantage of fine sand in securing efficient bacterial filtration. Thus 1·8 foot of the fine sand of the New River Company and 2·75 feet of that of the West Middlesex Company are respectively more than twice as efficient as 4 feet of the coarser material used by the Chelsea Company. It is true that the West Middlesex Company filters somewhat more slowly than the Chelsea Company, but, on the other hand, the filtration rate of the New River Company is considerably greater than that of the Chelsea Company. Indeed, the rate of filtration adopted by the New River Company is considerably higher than that of any other Metropolitan Company, and yet the bacterial efficiency of this Company's filters surpasses that of all the others.”

The considerations that guide us in determining the thickness of the fine sand are the quantity that will be removed by scraping before the sand can be washed or fresh sand brought in to replace that which has been removed, and the minimum depth of fine sand necessary for efficient filtration. In the extract from the Army Medical Report that I have just read out to you, it was stated that Professor Koch was of opinion that the real filtering medium was not the sand itself, but the gelatinous mass of protoplasm or bacteria which was unable to pass at

once into the sand, and which was therefore collected on the surface. With ordinary clear water, such as is obtainable in the cold and hot weathers, this film collects very rapidly and eventually clogs the filter, so that it has actually to be scraped off about once a month. In the flood season, in spite of the clarification of the water in the settling tanks, a large quantity of impalpable silt still remains in the water that is discharged on to the filter-beds; so that not only have we to deal with the film of protoplasm, but this silt has a great deal to do with the clogging of the filters, and it seems to pass right into the sand. Consequently filters have to be scraped at least every week or ten days during the rains. During the cold and hot seasons only about  $\frac{1}{4}$ " of sand need be removed at each scraping, but at other times of the year as much as an inch has at times to be taken off every time; the aggregate of these scrapings may amount to 12" or 18". During the flood season no sand is obtainable from the river beds, and the scrapings removed at this time of year are generally too dirty to be washed, and so we have to wait well into the cold weather until we can replenish the filtering material. The minimum depth of fine sand for efficient filtration is 12", and consequently the primary thickness of the fine sand ought never to be less than 2' 6"; allowing for the slope of the filter-bed floor, this means that we must have 2' 6" of fine sand at the sides and 2' 9" or 3' at the centre over the main drain. I do not think anything is gained in India by having a greater thickness than this, as it is extremely doubtful whether any extra thickness of fine sand has any greater purifying powers; and, of course, it has the great drawback in increasing the depth of filter-bed tanks, and therefore the cost of construction. The depths of fine sand in the filter-beds of the London water-works vary between 1.8 and 4.0 feet, the average of all the works being 2.5 feet; the total depth of filtering material varies from 8' to 3' as against the 3' which has been found to be sufficient in this country. The filter-beds, however, of the London works were constructed before the true principles that regulate the purification of water by means of filtration through sand were actually ascertained. In 1893 I was deputed by Government to report on the water-supply of the City of Berlin, and I found that in the most recently constructed filter-beds the depth of fine sand was 2 feet, and the total depth of filtering material was 3 feet, this depth being arrived at after a series of experiments, extending over two or three years, with the various forms of filters that were best calculated to suit the water that had to be purified. In the course of these experiments it was discovered that sand that had been used in filters was much more effective as a filtering material than fresh sand; for it appears that each particle of sand gets covered, after having been used in a filter, with an envelope of gelatinous matter, simply teeming with the microbes that have the most beneficent effect on water. It is, therefore, most important that as much as possible of the sand that is scraped off filter-beds should be washed and cleaned and then returned to the filter-beds, even if it costs more than bringing in fresh sand. In the older water-works of Bengal, such as Dacca, Bhagalpur, and Burdwan, no provision for sandwashing was made, but this state of things is now being gradually remedied, and in all recently-designed water-works both in the North-Western Provinces and Bengal this omission has been supplied. I have given in Plate No. 6 a design for a sand-washer which has been

found to work very effectively. It consists of a masonry vat at the bottom of which are placed a series of frames covered with zinc or iron sheets full of small holes. Underneath these frames pipes connected with the high pressure main are fixed. The sand to be washed is filled in on top of the frames. The water is then turned on, and it forces its way up through the sand, carrying with it the particles of silt mixed with the dirty sand. The dirty water overflows into drains provided for the purpose, and only the clean sand is left in the vat. While the washing is going on the sand should be continually stirred with long rakes or bamboos, so as to loosen it up and allow the water to pass through it freely. Several machines for washing sand have been devised, but they are hardly suitable in a country where labour is so cheap.

Having thus explained to you the considerations that must guide you in deciding on the design of the cross-section of a filter, we must now go into the question of the area of filter-bed that will be required for a given quantity of water. This must necessarily be decided by the rate at which the water is to be filtered, which in the case of the London water-works is as follows:—

COMPANY.	Rate in gallons per square foot per hour.	Rate in inches vertical per hour.
Chelsea ... ..	1.75	3.4
West Middlesex ... ..	1.25	2.4
Southwark and Vauxhall ... ..	1.50	2.9
Grand Junction ... ..	1.63	3.1
Lambeth ... ..	2.08	4.0
New River ... ..	1.89	3.6
East London ... ..	1.33	2.6
Average ... ..	1.63	3.1

In the Berlin works the rate of filtration is 2.08 gallons per square foot, or 4.0 inches vertical per hour, which is in accord with the recommendations made in the Report of the Royal Commission on the Metropolitan Water-supply.

In designing new works for this country I should feel inclined to make the rate only 3 inches per hour, because this would then leave a margin for increasing the supply without going to the expense of building additional filters and so obviate, what is frequently done, forcing the filters as the demand increases. Now with regard to the number of hours that filtration is to be carried on. Opinions are many and various on this point: some contend that filtration should be continuous day and night until the filter gets clogged, while, on the other hand, the experiments of the State Board of Health of Massachusetts show, as I have already explained to you, that chemical purification was much more complete when the water was exposed to more air while passing through the sand. In fact, it is another case of the intermittent *versus* the constant system. In European countries, however, the supervision is very perfect, and the filters are carefully watched night and day;

but in this country work done during the night is always more or less of an untrustworthy character. Filtration, as I have already observed, is a very delicate process, and should therefore never be left to take care of itself. Consequently I am of opinion that for this country the intermittent system of filtration is the better; it has been in use at all the water-works in Bengal for the past three years, and I have never heard any complaints against the quality of the water produced by the filters. Sixteen hours out of the twenty-four, or, say, from 5 A.M. until 9 P.M., appears to me to be the proper period during which filtration should be carried on, and for the other eight hours the water is run out of the filter-beds and air rushes in and takes its place. We may therefore design our filters to pass 25 gallons per square foot or 48" vertical per working day, as against the 39 gallons per square foot per working day of the London filters, the difference being due to the length of time during which the filters are at work. At the Calcutta Water-works the rate of filtration varies, according to the season, from 33 to 40 gallons per square foot per 24 hours, or about the London rate. Now, having determined the rate of filtration per square foot per day, an algebraical sum will give the total filtration area required.

Taking into consideration the cost of construction and that of working, it has been found in England that 30,000 square feet is the best superficial area for each filter-bed when a large quantity of water has to be dealt with; and this area can most economically be supplied by a filter 200 feet by 150 feet. At the Calcutta works the filters are all 200 x 100 and are 36 in number, of which 32 are in general use. At Howrah four filters 180 x 80 have been provided; with one under repair, this allowance is hardly sufficient, as a rate of 25 gallons per square foot only gives 1,000,000 gallons per day, and 1,300,000 will eventually be required. This installation of filters, however, was designed before the good results of intermittent filtration were fully ascertained and recognized. In the newly-designed works at Berhampore two filters have been provided, each measuring 103 x 78, and these can each provide the whole day's discharge when working at the rate I have recommended. In small works like those of Berhampore perhaps it would have been more economical to provide three filters, each capable of delivering half the day's supply; there would thus have been two filters at work and one under repair, but there were other considerations which prevented this arrangement being carried out. In deciding the number of filters required for a given supply you must always remember that each filter must be thrown out of work at least once a week during the flood season.

The arrangements for discharging water into and from the filter, as also those for ventilating the under-drains, will be best understood from the drawing which I now place before you.

Plate No. 7 shows the design of the Berhampore filter-beds, which you will see have been designed on the principles I have already explained to you. There are one or two deviations from the usual design of such works which I think I should explain. The first one is regarding the filtering material: this consists of 1' 6" of fine sand lying over 12" of coke-breeze; the reason of the insertion of this latter material in a water-works filter-bed is that it has been proved to be so

successful in purifying sewage, and the water of the Bhagirathi, whence the supply for Berhampore is obtained, contains an unusual amount of organic impurity when compared to other rivers, and so I considered it desirable to at any rate make the experiment with coke; for even if it is not a success, it can easily be removed and replaced by fine sand. The second novelty is in regard to the method of discharging water on to the filter. The usual arrangement is to have one bell-mouthed pipe discharging on to the surface of the sand either in the centre of the bed or at one end; two bell-mouths, or spreaders as they are called, have been provided with a view to making the filtration at all parts of the filter-bed more uniform. You will also observe that the spreaders are provided with sheet-iron deflecting plates; these are to prevent the water going down the sides of the spreaders without first passing through the sand. Instead of the usual pattern of dewatering-box, for running water off the surface of the sand when the filter becomes clogged, a two-inch pipe has been run along the top of the main drain in continuation of the pipe supplying the spreaders, and connected with the sludge outlet of the filter well. If, then, it is required to dewater the surface of the filters owing to their getting choked, the water can be run back through the spreaders into the sludge drain. The filtered water outlet pipe from the filtration well has been so fixed that the "filtration head," as the difference of level of the water in the filter-bed and that in the filtration-well is called, can never exceed six inches; I have found this a very necessary precaution where water-works are frequently left to the control of poorly-paid and ignorant men.

Having described the construction of filter-beds, I must now explain to you how, in my opinion, they ought to be managed, and I give below a copy of rules which I devised, and which have received the approval of the Sanitary Board, Bengal :—

RULES FOR WORKING FILTER-BEDS OF WATER-WORKS  
IN BENGAL.

(Revised by order of the Sanitary Board, Bengal, 26th May 1896.)

1. The depth of water above the surface of the sand in a filter-bed should never be allowed to exceed two feet; care should be taken to always maintain this depth of water as long as filtration is in progress, and for this purpose gauges should be painted on the side walls of the filter-beds.

2. The water collecting in the drains of a filter-bed is usually discharged into

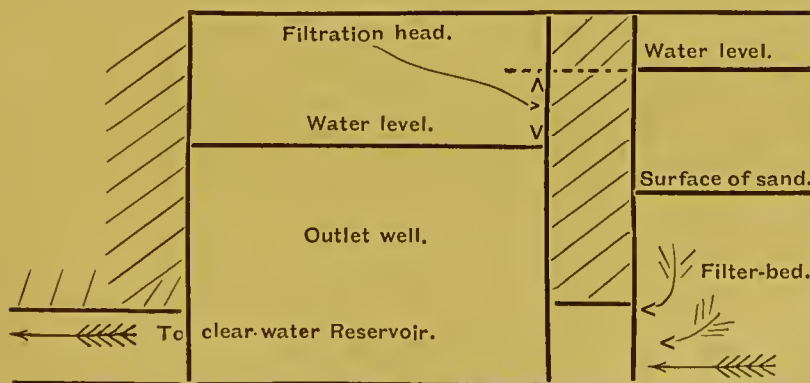

a small masonry well called the *outlet-well*, from whence it passes through a sluice into the clear-water reservoir; the difference of level between the surface of the water in the filter-bed and that in the outlet-well is called the *filtration head*; the rough sketch in

the margin explains this clearly. The *filtration head* should not under ordinary

circumstances exceed *six inches*, but in cases of emergency it may be allowed to reach as much as twelve inches. Full reasons for allowing the filtration head to exceed six inches should be recorded in the filter-bed log-book.

3. The interiors of outlet-wells should be painted white, and gauges should be painted on the side walls, so that the filtration head may be accurately recorded.

4. Readings of all gauges should be taken every two hours while the filters are at work, and recorded carefully in the log-book (Sanitary Engineer's Form No. 5) or in any other form approved by the Sanitary Engineer.

5. Filter-beds should not be worked continuously, but the surface of the filtering material should be exposed to the air for at least eight hours out of the twenty-four, so as to enable the air to penetrate, and so oxidize any organic matter deposited in the interstices of the filtering material by the unfiltered water. Filter-beds should, preferably, be run dry at night time only.

6. Filter-beds should *not* be charged from below or by admitting water upwards on to the surface of the sand. When a filter-bed is to be brought into work the outlet valve should be kept closed until the depth of water on top of the sand remains at the limit prescribed in rule 1, *i.e.*, two feet; care should be taken not to disturb the surface of the sand by admitting water too rapidly at first.

7. Sand that has been scraped from the surface of filter-beds should be left exposed to the air for six or seven days before it is washed and replaced in the filter-beds.

8. The fine sand in a filter-bed should never be reduced by scraping to a less depth than 12 inches. When sand washers are available, the fine sand should be brought up to its correct thickness after every third scraping, so that the rate of flow through the filtering material may be kept as uniform as possible.

9. The filtering material and brick drains should be entirely removed from the filter basin once every four years. The pebbles or broken stone and the coarse sand may be replaced, provided they have been thoroughly exposed to the air while the brick drains are being laid; they should be spread out in thin layers and turned over with spades at least once a day. The fine sand should be entirely renewed. When a filter-bed has been reconstructed and recharged, the filtered water flowing from it should be allowed to run to waste for at least 48 hours.

SANY. ENGR.'S FORM NO. 5.

WATER-WORKS.

Filter-bed Log for the

of

189 .

Number of filter-bed.	Hour.	Level of sand.	Level of water in filter-bed.	Level of water in filter-well.	Filtration head.	NUMBER OF TURNS OPEN.		Depth of water in clear-water reservoir.	REMARKS.
						Inlet valve.	Outlet valve.		

Superintendent.



*Notes for Form No. 5.*

1. All gauges should be read every two hours at least, and also, whenever it is necessary, to open, close or alter the inlet or outlet valves.
2. All levels to be referred to the bottom of the filter-bed, *i.e.*, the zero of the gauge to be on the floor of the filter-bed.
3. In the column of remarks should be entered an account of repairs, etc., done to the filter-beds, such as scraping, or renewal of filtering medium, number of cubic feet of sand removed from a filter-bed, and the quantity washed, etc., etc.

I think I should now explain the reason of each of these rules.

In European countries the depth of water on the top of the sand has to be sufficient to prevent the latter from being disturbed by the formation of ice in the winter. In the London water-works the depth of water in the filters varies from 3 to 7 feet, the average being 4 feet 8 inches; in the new Berlin filters it is 4 feet 3 inches. In this country we are not bothered with low temperatures, and all that we have to do is to give such a depth of water as will prevent the growth of vegetable matter and algæ on the surface of the sand. For filtration purposes it would be quite sufficient if we had a thin layer of water, say 1 inch deep, just flowing over the sand, but the heat of the sun quickly penetrates so small a depth of water and at once causes the vegetable germs and seeds to sprout. Experience has shown that a depth of 2 feet is all that is necessary to prevent any growth on the surface of the sand. I need hardly point out that the greater the depth of water over the sand, the more costly the filters will be. The filters should be designed for a depth of 2 feet of water, but there is no reason why this depth of water should not be increased as the sand is scraped away; in fact, perhaps it is better to keep the surface of the water always at the same level, because then the floating gauges will always show the filtration head correctly. Marks should be made on the walls of the filter-beds to show the normal water level.

The next rule (No. 2) is the most important of all, relating as it does to the filtration head, and consequently to the rate of flow in the filters. The first principle of all efficient filtration is that the flow through the filters should be regular and at a constant rate. The flow of water in a filter is produced by the difference of level of the water in the filter and that in the outlet-well. As I have already explained, filters get gradually clogged by the deposition on and in the sand of the microbe slime and silt from the water: consequently, if the rate of filtration is to be constant, the filtration head must gradually increase in order to overcome the resistance offered by the slime and silt. The amount of head necessary to force water through a clean filter depends entirely on the design, for the head is entirely absorbed in overcoming the friction between the water and the grains of sand, and that between the water and sides of the under and main drains. A large filter with long drains and a great thickness of sand will therefore require a greater head to produce a given quantity of water than would another with shorter drains and a less thickness of sand. It is therefore very difficult to lay down any rule as to the filtration head required to produce a certain discharge. All that can be done is to fix a limit above which

the filtration head should not be allowed to go. Now, you will understand that if there is a difference of level of the water in the filter-bed and that in the outlet well, there must be a pressure thrown on to the surface of the sand equal to the weight of water of the same area as the filter-bed and in depth equal to the filtration head. If, therefore, the filtration head is 6 inches, the weight on each square foot of filter-bed will be 31·2 lbs. ; if it is a foot, the pressure will be 62·4 lbs. This pressure naturally tends to consolidate the sand, and prevents the passage of water through it, and it also forces the microbe slime further into the pores of the sand. In order to prevent these things happening as far as possible, I have decided that the maximum filtration head shall be only 6 inches. This has given very good results so far, and I know at present of no reason why it should be increased. I have known cases in which it has been increased, and the water produced by the filters was not at all satisfactory. At the Calcutta works the maximum head allowed is 12 inches, and in some of the European water-works it is allowed to go as far as 2' 6", but I am bound to say that I cannot see that any useful purpose is served by putting so much extra pressure on to the filters ; it may be possible to carry on filtration a few days longer with these large heads, but it certainly means that greater thicknesses of sand have to be removed at each scraping. Above all things, remember that the rate of filtration should be constant throughout the time the filter is working.

Rules 3 and 4 do not require any explanation

Rule 5 refers to the intermittent system of working the filter-beds and explains the reasons. I have already referred to the matter and told you what caused me to arrive at the conclusion, that for this country intermittent filtration is preferable to the constant system.

In many of the older water-works the system of charging filters was to admit water from the clear-water reservoir into the under-drains and allow it to rise gradually through the sand, the idea being that this system would prevent what are called "blow-holes" in the sand ; for some years past I have charged filters from above, and I have never been bothered with these, and I do not see how they can be made if the under-drains are properly ventilated, as they are in all properly-designed filters. Personally I believe that this system of charging filters from below is a relic of the days before ventilation from the under-drains up through the side-walls were ever thought of. By charging filter-beds from the top the air in the interstices of the sand is gradually forced out through the drains, and they are therefore aerated more thoroughly by all the air from the sand above passing through them than they would be if the water were admitted from below. We all know that microbes are ever-increasing quantities, and consequently that the water in the clear-water reservoir contains more microbes than that from the outlet well ; if, then, filters are charged from below, it seems to me that we introduce microbes into the very places from which we want to get rid of them, namely, into the under-drains.

I have already explained to you why the fine sand that has already been used for filtration and afterwards washed is much preferable to sand fresh from a river-bed, and much more effective as a filtering material by reason of the envelope of microbial matter in which each grain is

enclosed. By exposing the sand to the air after it has been removed from the filter-bed the microbes in the sand are given a fresh lease of life as it were, and any organic matter that may have been deposited in the sand is thoroughly oxidized and rendered innocuous. Unfortunately air is not capable of destroying and removing the impalpable silt with which the fine sand gets choked during the flood season, and by about the end of four years this silt has penetrated right down to the bottom of the fine sand, and more often than not into the coarse sand and pebbles. The fine sand is generally so dirty that it costs a great deal to thoroughly wash it, and very often consumes more filtered water than the works can spare; the only way then is to bring in an entirely fresh supply of fine sand, wash it in filtered water, and then place it in the filter-beds. Here I should remark that in constructing filter-beds in the first instance only one bed should be filled up with filtering material at first, and then the filtered water will be available for washing the filtering material for the other beds; when these have been completed all the material should be removed from the first bed and thoroughly washed in the filtered water obtained from the other filter-beds.

It has been found that water from a freshly constructed or recently scraped filter-bed is never so pure as that from a filter that has been in work for some days, the reason being that it takes some little time for the scum or film of microbes to be deposited on the surface of the sand. This will explain the last sentence of rule 9.

It is usual in water-supplies in India to arrange that half the daily supply shall be delivered in four hours, but if the filters only deliver the whole daily supply in 16 hours, it follows that there must be some arrangement for storing the water as it leaves the filters. This is generally done in covered brick masonry structures which are known as "clear-water reservoirs." The roof may be carried on pillars, but the preferable arrangement is to have a series of walls running across the reservoir and between which arches are turned. These walls serve a double purpose, for not only do they carry the roof, but they cause a constant circulation of the water inside. If half the daily supply is discharged in four hours and the filters can only give the full day's supply in 16 hours, a simple arithmetical calculation will show that the clear-water reservoir must contain at least a quarter of a day's supply; it is usual, however, to provide for not less than half a day's supply, but if it can be managed it is desirable to provide for a whole day's supply, more especially if the pumps that lift the water from the river are not in duplicate. The clear-water reservoir then acts as a storage reservoir also.

Plate No. 8 gives the design of the clear-water reservoir for Howrah, and in plate No. 7 is that for Berhampore. It will be observed that the reservoir at Howrah is built with two compartments; this is to enable one side to be closed for repairs without interfering with the daily supply, but as a rule both compartments are in use at the same time. This would have been done at Berhampore, but funds were not available.

To give you some idea of the extent of the purification that is effected by filtration through sand I must quote another extract from

Sir E. Frankland's report on the London water-supply for the year 1896-97. The following table is derived from that report :—

NEW RIVER COMPANY.

*Reduction of micro-organisms by filtration alone.*

MONTH.	ORGANISMS PER CUBIC CENTIMETRE—		Percentage of organisms left in.
	Before filtration.	After filtration.	
January ... ..	1,040	26	2·5
February ... ..	1,580	24	1·5
March .. ..	1,820	12	0·7
April ... ..	500	4	0·8
May ... ..	300	12	4·0
June ... ..	420	24	5·7
July ... ..	480	20	4·2
August ... ..	340	4	1·2
September ... ..	660	12	1·8
October ... ..	820	12	1·5
November ... ..	4,880	162	3·3
December ... ..	7,480	266	3·1
Mean ... ..	.....	.....	2·5

The following table shows the maximum, minimum, and average percentage of microbes removed at the seven London water-works where the water is purified by filtration :—

COMPANY.	PERCENTAGE OF MICROBES REMOVED.		
	Maximum.	Minimum.	Average.
Chelsea ... ..	99·92	99·62	99·86
West Middlesex ... ..	99·94	91·48	99·79
Southwark and Vauxhall ... ..	100·00	84·33	97·77
Grand Junction ... ..	99·98	84·03	99·31
Lambeth ... ..	99·97	96·45	99·81
New River ... ..	100·00	77·14	99·07
East London ... ..	99·93	97·03	99·56

The samples of water submitted to bacterioscopic examination were collected at the works of the respective companies immediately after

the water left the filters and before it was pumped into the distributary mains. It is of little use examining filtered water delivered from the mains, not only because it is a mixture of the effluents from many filters, but especially because the multiplication of ordinary river and harmless microbes is so rapid, that the number is generally increased many times over between the filtration works and the standpipes. By the examination of the water as it issues from the filters the utmost freedom from microbes or maximum degree of sterility of each sample of water is determined. This utmost freedom from bacterial life after all sources of contamination have been passed is obviously the most important moment in the history of the water, for the smaller the number of microbes found in a given volume at that moment, the less is the probability of pathogenic organisms being present, and, although the non-pathogenic may afterwards multiply indefinitely, this is of no consequence in the initial absence of the pathogenic. The results given in the above tables are, I think you must admit, most instructive; they show us how very impure even unfiltered water in England is, and they prove beyond all doubt how great are the benefits of careful filtration.

I think it will be desirable if I say a few words to you regarding the methods of ascertaining the purification attained in large water-works by filtration through sand. There are two methods employed, namely, the chemical and the bacteriological, but the investigations of Miquel in Paris, Koch in Berlin, and Angus Smith in England have shown that the latter method is much more reliable in warning us of the purity or otherwise of our drinking-water. It must not, however, be supposed that the bacteriological test in any way replaces or supplants the chemical test; such is by no means the case. But the former is by far the simplest test to carry out, and it has consequently become the more popular, thanks to the method of plate cultivations in nutrient gelatine propounded by Koch. By this method a small quantity of the water to be examined is intimately mixed with fluid gelatine, which is spread in a thin layer upon a glass plate, or it may be left in the test tube which is laid in a nearly horizontal position; the gelatine is allowed to solidify and the germs or micro-organisms thus become fixed and proceed to grow or form "colonies," each germ growing separately in the gelatine wherever it may have lodged, and not interfering with the development of the other germs. After a day or two spots about the size of pin-heads begin to be visible in the gelatine: these are the colonies of germs; and if they are counted, the number will be that of the original germs in the sample which we examined. In this country Japanese isinglass or agaragar appears to be more suitable than gelatine as the nutrient medium on account of its being able to resist somewhat higher temperatures. The method of mixing the water with the gelatine and the precautions to be observed are very clearly described in a small pamphlet written by Mr. E. H. Hankin, Chemical Examiner and Bacteriologist to the Government of the North-Western Provinces and Oudh, for the use of Municipal Engineers and others interested in providing water for drinking purposes; the pamphlet is entitled "The Bacteriological Test of the Purity of Water." At some of the water-works in Bengal this method of examination of the water-supply is being carried out by the

Superintendents with very satisfactory results; but all large European water-works have special laboratories, and entertain a special staff of chemists and bacteriologists for the daily examination of the water supplied.

Before I leave the subject of the purification of water, I think I ought to say a word or two on domestic filters such as may be used in your own houses or in large public institutions, although I have said that I did not intend to refer to any of the mechanical filters that are now before the public, but those remarks were intended to apply only to the use of mechanical filters for public water-supplies. When water is supplied by a municipality or any other public body it should be sufficiently purified, before distribution, as not to require any further filtration. But the number of public water-supplies is very small, and most of the water in this country is drunk in an unpurified condition. In public institutions, such as barracks, hospitals, jails, etc., where a supply of pure water is an absolute necessity, some form of domestic filter must be used. The present practice in jails in Bengal at present is, I believe, to pass the water through ordinary small sand and charcoal filters and then boil it. Boiling no doubt produces absolutely pure water as far as microbes and bacteria are concerned, because the heat simply kills them all off, or, as it is usually called, it sterilizes the water; but boiling also drives all the air out of the water and renders it very flat and insipid and consequently unpleasant to the taste. Many substances have been used for the purposes of domestic filtration, and for a number of years animal charcoal held the leading place on the list of filtering materials. Recent experiments and researches have, however, shown that although it possesses considerable oxidising powers on organic impurities present in water, it does not sterilize it, but, on the contrary, favours the development of microbes and bacteria in the water. Water filtered through animal charcoal rapidly deteriorates as the charcoal yields up impurities to water, so that in many cases the water is more impure after it has passed through the filter than it was originally. On the whole, there is perhaps no material more unsuited or unsafe to use as a filtering medium for potable waters than animal charcoal. This cannot be too widely known, as it is still advocated in many standard works as being the best filtering material, notwithstanding the fact that recent investigations have shown it to be the very reverse.

Among other substances used for filtration, all of which have been proved, like animal charcoal, to be open to some grave objection, are silicated carbon, that is, fine silica impregnated with charcoal, hæmatite and magnetic iron ores, the so-called magnetic carbide, spongy iron, manganic oxide, flannel, wool, sponges, porous sandstones, etc., etc.

At present the only filters that give filtrates practically free from germs are earthenware filters on the Chamberland-Pasteur and Berkefeld principle. The following description is taken from Notter and Firth's "Theory and Practice of Hygiene":—

"The Chamberland-Pasteur is the best of all domestic filters. Its construction is very simple, for it merely consists of a cylinder of unglazed porcelain (bougie) made from a well-baked kaolin of a certain degree of porosity and hardness, closed above and terminating below in

an open nozzle. This cylinder is enclosed in a metal or glass jacket, a space intervening between the two, above and at the sides, while below they are fixed together by a screw tap, with an opening in the centre for the passage of the nozzle. The outer cylinder is closed above, except where it joins the water-pipe. The water passes through the porcelain from without inwards and under a pressure of from  $1\frac{1}{2}$  to  $2\frac{1}{2}$  atmospheres, such as is usually present in the pipes of a water service, at the rate of about three quarts per hour. These filters can be easily cleaned by brushing under a stream of hot water, and afterwards, if deemed desirable, by submitting them to the action of steam, or by heat applied direct from a spirit lamp or Bunsen burner. This filter acts mechanically, and is most efficacious in removing the finest suspended matters, and even micro-organisms are stopped by it. The Berkefeld filter is on the same principle as the Chamberland-Pasteur; it is made of infusorial earth, which is somewhat soft and friable and liable to fracture. This filter, however, possesses distinct sterilizing action, inasmuch as it is capable of removing bacteria from samples of water and other impure liquids passed through it. Its action is practically similar to the Chamberland-Pasteur filters, but whether it possesses any superiority over them is doubtful. On the contrary, the bougies are brittle and liable to fracture when moist, and further experimental proof is required to show whether or not the frequent cleansing of the filter by brushing will not wear away the bougie too rapidly—a contingency which we know in the case of the Chamberland-Pasteur filter does not exist.”

Where a larger quantity of water than three quarts per hour is required, a larger number of candles or bougies must be used, and if they are working under pressure they must be enclosed in a screwed-down iron case. In the ordinary domestic filter of 4 or 6 candles the action is syphonic, and is therefore due to the pressure of the atmosphere alone; the candles can therefore be placed in any receptacle. As regards the cleaning of the candles of the ordinary domestic filter, I have found the simplest way is to disconnect them from the rubber tubing and then boil them for half an hour in an ordinary saucepan. These filters are no doubt most successful in large institutions where they can be properly looked after, but they are out of the question for town water-supplies. I have heard it argued that, if you have a 100 filters in 100 different houses, these houses can be equally well supplied with water if the 100 filters were all collected under one roof. Theoretically this is a correct argument no doubt, but it is quite certain that it is not a practical one, as has been shown in the case of a town in which these filters have been installed to deal with the whole water-supply. At this installation 8,750 candles contained in 33 cast-iron cases have been supplied, and a recent bacterioscopic examination of the unfiltered and filtered water has shown that the latter contains more microbes than the former. The reason of this probably is that the microbes have grown through the pores of the candles, for the cleansing is accomplished by rubbing the outsides of the candles, which are for this purpose removed from the cases, with ordinary soap, and then soaking them for 12 hours in chloride of lime solution. This process of cleansing is evidently not efficient, for the chloride of lime will not act on microbes growing in the pores of the filter walls.

## THE RAISING OF WATER.

This will, I think, gentlemen be a fitting opportunity to introduce to you the subject of the means of raising water whose level is too low for it to be used or distributed by gravitation. In the ordinary sequence of these lectures this subject should no doubt have come immediately after the section devoted to the collection of water, and equally too it should come after the section on the distribution of water which we have not yet reached. We will therefore compromise the demands of the collection and distribution of water and discuss it now after the former and before we reach the latter. Taking the methods indigenous to this country, we have—

- (1) baling, which is universal all over India,
- (2) the Persian wheel of the Punjab,
- (3) the Lât or Paecottah of Bengal,
- (4) the Môt of the North-Western Provinces;

and, placed in the above order, they give the relative efficiency of each in regard to the quantity of water raised per rupee, the môt of the North-Western Provinces being the most efficient. Of these four methods, I think only Nos. 2 and 3 are at all suitable for lifting water that is intended for drinking, because baling is only suitable for small lifts, which are seldom, if ever, met with in water-supply questions, and the môt involves the use of a large leathern bag, of the cleanliness of which we cannot be at all certain. The lât and the Persian wheel, on the other hand, are suitable for comparatively large lifts, and the vessels used for the conveyance of the water are made either of iron or earthenware which can always be kept clean, and do not accumulate filth on them. For small village wells the lât is especially suitable, as it obviates the necessity of the users of the well dipping their own, very often exceedingly dirty, vessels into the water. With a lât two men can raise water from a depth of 36 feet, at the rate of something like 250 gallons per hour. The Persian wheel involves the use of bullocks, but it can raise water at the rate of 800 gallons per hour at least from a well 40 feet deep; this method might be used where the public draw off their water from a low level covered masonry tank with taps fixed in its sides. The môt might be used for raising water for flushing drains, as it can raise water at the rate of 1,400 gallons per hour, the only difficulty about its use in a crowded town being the length of run required for the bullocks.

As regards mechanical pumps, I propose to divide them into two divisions—(1) those that are worked by hand, and (2) those which are kept in motion by steam-engines. The former are applicable in one or other of their various forms in many more cases than the latter, which are only used in the case of large town-supplies. I do not propose to give you a long dissertation on the subject of pumps, because I am sure you have already learned to distinguish between a bucket and a plunger pump, and can tell as well as I can whether a pump is single or double acting. All that I intend to do is to bring to your notice the kinds of pumps which, in my opinion, will be most useful to you hereafter when you are called upon to advise on any question of raising water.



I do not suppose it has ever occurred to you, or that you have noticed for yourselves, that the actual drawers of water for a family are the women and children; it is the same in all countries, because the women are the house-keepers, while the men have to go forth to heavier labours to earn the daily bread. It is therefore necessary that the power required to work a pump should be within the strength of the users, namely, the women and children. The next desideratum in a hand-pump is that it should have as few moving parts as possible, and should be absolutely simple in construction and with as few bolts and nuts as will keep it together in working order; in fine, that it should be a perfectly simple machine, such as an ordinary village mistry can take to pieces, repair and put together again when it gets out of order. And, lastly, the pump should be worked by a rotary motion in preference to a lever, because with the latter it is so seldom that a full stroke is made, and consequently it takes so much longer and such a much greater effort to get the quantity of water required. The only pump that I know that fulfils all these requirements is what is known as the rotary pump, which consists of a pair of very coarse toothed-wheels geared into each other and with their sides fitting against the outer casing of the pump. As the teeth of these wheels revolve past the inlet-pipe they produce a partial vacuum which is filled with water, and as the revolution of the wheels is continued the water is pushed out of the discharge-pipe. The capacity of rotary pumps with suction pipes varying between  $1\frac{1}{4}$  inches to 2 inches is from 14 to 36 gallons per minute per 100 revolutions, but they cannot be used when the water level is more than 20 feet below the pump.

And this leads me to say a few more words regarding suction pipes. As you are aware, water is drawn up a pipe by exhausting the air at the top of the pipe, the pressure of the atmosphere on the water in which the pipe is immersed causing the motion. Theoretically the atmospheric pressure will support a column of water 32 feet high, and consequently it should be possible to lift water 32 feet by suction alone; but even with the most delicate and perfect air-pump it is impossible to get an absolute vacuum, and it is naturally all the more difficult when we are dealing with comparatively coarsely-made tools like water-pumps. In actual practice it has seldom been found possible to get any pump that will draw water regularly and smoothly from a greater depth than 20 feet, or at the very outside 25 feet, but in the latter case the suction pipe must be exceedingly short and the number of joints in the pipe very few, that is to say, the pump valves must practically be vertically above the water. I should strongly advise you never to try and lift water more than 20 feet by means of an ordinary lift, or rotary pump. When the depth of water is greater than this, the pump buckets will have to be separated from the driving gear, so that they can be lowered down to within 20 feet of the water while the driving gear remains at ground level. This class of pump, however, has to be provided with many complicated bolts and bearings, and, moreover, it is too heavy to be worked by women and children. If the wells are deep and a pump has to be used, then I should recommend that a small reservoir be provided which can be kept filled by men working the pumps; ordinarily, however, a lat or even iron

buckets pulled up by means of a pulley or an ordinary wooden roller and winch-handle are, I think, preferable and more suitable to the wants and pockets of the users than a complicated heavy pump. However, in those places where the cost of working a hand-pump can be borne by users of the well or tank or whatever else is the source of water, you should always remember that a rotary pump is always preferable to a lever pump, but beyond this I do not think I have any recommendations to make; there are so many different patterns of pumps to be had, and, as far as my experience goes, one pattern is as good as another.

Where water has to be raised from a well into a vat or reservoir for flushing drains or watering roads, and the depth of the water is greater than 20 feet below the top of the well, a very useful pump is what is known as the chain-pump. This consists of an endless chain carrying a series of discs and passing over a wheel above ground. The discs descend into the water with the chain, and on their upward journey pass through a tube, carrying with them a considerable quantity of water. Owing to their extreme simplicity these pumps are particularly well suited for rough usage; they can be readily repaired and altered to suit different depths. Although not economical in action for any but very low lifts, owing to the dead weight of the apparatus to be moved, it is capable of working with a lift of 50 or 60 feet, but I do not think I would recommend it for depths over, say, 35 feet at the very outside, and for this two coolies at least will be required. If it were not for the simplicity of construction, it would no doubt be more economical in the matter of labour to use, in cases where the water is over 20 feet below the surface, one of the numerous patterns of lift and force pumps.

When large supplies of water are required the pumps are generally actuated by steam-engines, although, when plenty of water is available, some form of turbine or water-engine may be used with advantage. With the perfecting of electrical motors, we are even reading of the installation of electrically driven pumps. Steam-pumps, however, are likely to hold the field for many years to come yet on account of their comparative economy and regularity of working. The art of designing pumps, and steam-engines to drive them, is a special branch of the profession of mechanical engineering, so that should you ever have anything to do with the purchasing of steam-pumps, I should strongly advise you to simply state what your requirements are, which will be so many gallons per hour lifted so many feet, and then ask some of the leading manufacturers to submit tenders or proposals. In stating your requirements for the information of manufacturers, you should also explain with levels the position of the engine-house with regard to the source of supply of the water, giving, of course, the lowest known level of the water; this information is required to enable the manufacturers to fix the position of the pump-valve chamber, because if the suction pipe is a very long one, a certain amount of pressure will be absorbed in overcoming the friction of the water in the pipe, and the head of water producing this pressure will have to be deducted from the actual static lift. I have already explained why small pumps should never be more than 20 feet above the water level, and these remarks apply equally to steam-pumps; consequently if, say, 2 feet

of head is absorbed in overcoming the friction in the suction pipe, the pump-valves must be placed only  $20 - 2 = 18$  feet above the water level.

The principal item of cost in maintaining and running steam-pumps is the cost of coal; manufacturers should therefore be called upon to state in their tenders the "duty" which they are prepared to guarantee. I daresay most of you remember, from your lectures on the steam-engine, that the word "duty" means the amount of work done in foot-pounds per cwt. of coal per hour, and it is usually calculated from the indicator-diagrams and the quantity of coal actually consumed; in pumping engines, however, the duty is usually calculated, not from the indicator-diagrams, but from the actual work done by the pumps, that is, the product of the actual weight of water delivered and the height to which the water is lifted. The duty of small pumping plants cannot be compared with that of large ones for the reason that their mechanical efficiency is not so high, and on account of the external losses from radiation and leakage being obviously larger in proportion to the steam used. Again, as regards the boilers, the coal used for "lighting-up" and "banking" also bears a larger proportion to the total coal burnt in small installations than it does in large ones. Thus, for the small engines at Berhampore, which are designed to raise 25,000 gallons per hour to a height of 124 feet, a duty of only 28 millions of foot-pounds per 112 lbs. of best Welsh coal is guaranteed; whereas at the West Middlesex Waterworks, with an engine raising  $1\frac{1}{2}$  million gallons per hour to a height of 51 feet, the ascertained duty was 101 millions of foot-pounds per cwt. of coal. In a batch of tenders, therefore, all other things being equal, you will accept that one in which the pumps give the highest duty, or, in other words, burn the least coal, and here I should observe that the heating power of Indian coal is only about two-thirds that of good Welsh coal, and so you will never get quite as good a duty with pumping engines out in this country as you do in England. The most satisfactory pumping engines are triple or compound, direct-acting, non-rotary, duplex engines, working with high-pressure steam of something over 100 lbs., and fitted with surface condensers. It is, I take it, quite unnecessary for me to explain the meanings of the words triple or compound, but the other expressions used in the above description may require a little explanation. A direct acting pump is one in which the pump rod is a continuation of the piston rod; it is in direct action with the steam end of the pump. Non-rotary engines are those that have no fly-wheels in order to maintain continuous motion or get over dead-centres; cranks and eccentrics therefore are not necessary. Duplex engines, as the name implies, are two separate engines placed side by side, but so arranged that the steam-valves of one are actuated from the piston rods of the other, and consequently there is always continuity of motion, as in the case of single fly-wheel or rotary engines; and the action of the valves is so designed that one pump commences its stroke before the other finishes, so that the motion of water in the suction and delivery pipes is very regular. Surface condensers are preferable to jet-condensers in water-pumping machinery, because the water can pass through a condenser of the former pattern without its quality being interfered with, whereas with the latter a certain quantity

of oil is always brought over from the cylinders. The only pumping engines in Bengal that are not provided with condensers of any sort are those of the Dacca Water-works, and the result is that the consumption of coal is at least twice as much as it ought to be.

As regards the pumps, for the unfiltered water single-bucket pumps and piston and plunger pumps, which give a varying discharge, should be avoided, because the column of water in the suction pipe, which is of considerable weight, has to be brought to rest at each stroke of the pump, and unnecessary strains are thrown on the valves and suction pipes; the best pattern to use is a duplex pump or a single acting three-throw bucket pump, driven either by a vertical or horizontal engine, but preferably by the former. For both the filtered and unfiltered water-pumps a design which has a number of small valves is infinitely to be preferred to one that shows only a few big ones; the former are much easier to repair, and do not give half, or even a quarter, of the trouble that large cumbersome double-, or treble-beat, or flap-valves do.

It has hitherto been usual to provide large air-vessels on the filtered water main, so that the cushion of air inside may take up the shock due to the variation in the rate of flow of water in the main. These, no doubt, are very necessary when the pumps are single acting or where water is delivered direct into distribution mains without first passing through either a stand pipe or an elevated reservoir. It has been found quite recently, however, that with large duplex pumps the air-vessel often causes them to work very noisily, although no explanation for this is forthcoming, and so I am inclined to recommend that air-vessels should still be provided on all delivery mains that do not discharge over a stand-pipe or into an elevated reservoir.

As regards boilers, you will probably do well to accept those recommended by the makers of the engines. Lancashire or Cornish boilers are very hard to beat where large quantities of steam are required. The Babcock-Wilcox tubular boiler has no particular merit beyond its being a quick-steamer and convenient for carriage. The ordinary locomotive multitubular boiler gives very satisfactory results for small installations of pumping machinery.

The cost of steam-pumping machinery with boilers and all the necessary auxiliary feed-water engines is rather difficult to calculate, because with engines less than 100 effective or pump horse-power the cost increases as the power decreases, although for engines over that power the cost does not vary very much. The following table of the cost in India of Worthington triple-expansion, condensing engines and pumps, with all necessary boilers, steam piping and connections, waste pipes, and erection, etc., is taken from Jones' Manual of Sanitary Engineering already referred to:—

Effective or pump horse-power.	30	25	20	15	10	5	2½
	£	£	£	£	£	£	£
Cost per horse-power horizontal engines...	48	55	65	75	100	130	170
Ditto, vertical do. ...	51	58	70	80	110	140	180

I should here observe that although vertical engines are more costly in the first instance, they cost much less in repairs than horizontal engines.

I have seen many cases of beautiful engines and pumps being allowed to get into such thorough bad order through carelessness or, more often than not, ignorance on the part of the Superintendent in charge, that I think it will be very desirable if I give you some idea of how the machinery of a water-works pumping station should be looked after, and what constant attention it always requires. Now, first and foremost, no installation of machinery is complete unless an Indicator has been provided and it is used regularly, say not less than once a month, to ascertain the power developed by the engine, and therefore the quantity of coal consumed per indicated horse-power. Time will not permit me to tell you all the information about an engine that an Indicator will give you, and I must refer you to some book on the subject like "Indicator Diagrams and Engine and Boiler Testing," by Charles Day. Every set of Indicator diagrams should be accompanied by a form giving the following information:—

#### DETAILS OF DIAGRAM.

Name of station \_\_\_\_\_  
 Date when taken \_\_\_\_\_  
 Distinguishing letter of engine \_\_\_\_\_  
 Cut off \_\_\_\_\_  
 Diameter of cylinder \_\_\_\_\_  
 Diameter of piston rod \_\_\_\_\_  
 Nett area of piston \_\_\_\_\_  
 Length of stroke \_\_\_\_\_  
 Revolutions or double strokes per minute \_\_\_\_\_  
 Pressure by steam gauge \_\_\_\_\_  
 Temperature of condenser \_\_\_\_\_  
 Vacuum on gauge \_\_\_\_\_  
 Pressure on pumps \_\_\_\_\_  
 Indicated H.-P., high \_\_\_\_\_  
 „ „ low \_\_\_\_\_  
 Total Indicated H.-P., \_\_\_\_\_  
 Consumption of coal per hour \_\_\_\_\_  
 „ „ per Indicated H.-P., per hour \_\_\_\_\_  
 Name of coal used \_\_\_\_\_  
 Quality of ditto \_\_\_\_\_  
 Scale of Indicator \_\_\_\_\_  
 Actual work done in ft.-lbs. per minute \_\_\_\_\_

and then if they are submitted regularly, your employers will be able to judge whether your engines are being kept in good order, that is, whether the actual amount of work done represents a fair percentage

of the power developed ; and whether the consumption of coal is appropriate to the size of the plant. Engines require watching daily and hourly, and as soon as the slightest defect is discovered, it must be attended to ; and above all things pay special attention to leaks in the steam-pipes and glands : nothing looks so bad as the steam blowing off in all directions in an engine-room.

The next form that I shall put before you is what is known as the engine-room log :—

————— WATER-WORKS.

ENGINE-ROOM LOG.

Engine at work.	HOURS WORKED.		Counter when engine started.	Counter when engine stopped.	Total revolutions made.	PRESSURE ON PUMPS.		Average pressure on pumps.	Total gallons pumped.	Total work in foot-gallons.	Work in foot-pounds per minute.	BOILERS AT WORK.			Coal in maunds.	REMARKS.
	From	To				Hour.	Feet.					1	2	3		
A.																
B.																
C.																

*Superintendent.*

*Dated*

From this you will see that another necessary adjunct of your engines are the counters showing the number of strokes made by the pumps. Without counters it is quite impossible to say with any accuracy what quantity of water is being dealt with by the engines, because in the case of the unfiltered water dimensions of the settling-tanks will not give us accurate information as to the quantity of water that has actually been pumped up, as no exact allowance can be made for loss by evaporation or percolation ; in the case of the filtered water-engines counters are necessary, because filtration is going on at the same time as pumping, and consequently water is flowing in and out of the clear-water reservoir. The counters should be checked periodically to find the amount of "slip" due to the full contents of the plunger not leaving and entering the pump-chamber at each stroke ; this can be done by closing the inlet of the clear-water reservoir and pumping out a certain depth of water, the quantity of which will be therefore known. The "slip" amounts as a rule to from 5 to 10 per cent. As regards the lift, this may be taken as the actual height of the pump-valves above the level of the water in the reservoir, be it tank, river, or well, *plus* the pressure in feet shown by a pressure gauge fixed on the pump-chamber ; this latter figure represents the actual height of the hydraulic gradient at the pump end of the main. If the suction pipe is very long, a foot or

two will possibly have to be added for friction in that. The lift must be observed and recorded every hour, and an average struck at the end of the day's pumping. The total work in foot-gallons will then be the total quantity of water pumped during the day, multiplied by the average lift; and from this figure the total work done in foot-pounds per minute is easily deducible, a gallon of water weighing 10 lbs.

The following form of inspection report will perhaps show you what points will attract the attention of the inspecting officer, and you should have your pumping plant in such order that he can only give favourable replies to all the queries contained in the report:—

*Report on an examination of the Boilers, Engines, and Pumps of the  
Water-works made by  
on the*

BOILERS.

1. Description of boilers, giving maker's name and date of erection.  
Give grate area and calculated horse-power.

2. When and by whom last examined—

(a) If examined by an Inspector of Steam-boilers under Act III (B.C.) of 1879, give name of Inspector and number and date of last certificate.

(b) Note working pressures previous to last examination; and, if any reduction in pressure was made by the Inspector, state how much, and why such reduction was made.

NOTE.—If the boilers are working under certificates granted by an Inspector under Act III (B.C.) of 1879, questions 3, 4, 5, and 6 need not be answered.

3. Have you examined the boilers internally and externally; if so, with what results? Give thickness of scale, if any, and state whether you had it removed.

4. Did you test the boilers by hydraulic pressure; if so, up to what pressure?  
Did you ascertain that the steam-gauges were correct, and that the steam-relief-valves were in working order, and not overweighted, before applying the hydraulic test?

5. What working pressures do you now recommend?

6. Have you examined all the boiler-fittings, such as safety-valves, feed water-pipe, blow-off cocks, steam and water-gauges, &c., &c.? State if they are all in good working order, and if not, what is required to make them so?

NOTE.—The safety-valves should not be weighted to more than 10 lbs. (preferably 5 lbs.) above the working pressure.

7. Are the boilers blown out regularly, and safety-valves lifted to ensure their not sticking; and is a record kept of the dates on which this has been done since the last inspection?

## BOILERS—concluded.

<p>8. Is the floor of the boiler-house kept dry and in good order?</p> <p>(a) Where are the ashes slaked?</p> <p>(b) When was soot last removed from the flues?</p> <p>(c) Are the flues free from moisture during the rainy season?</p>	
<p>9. State which of the following are available for filling the boiler, and which is generally used—</p> <p>(a) Feed-pump on engine.</p> <p>(b) Donkey-pump.</p> <p>(c) Injector.</p> <p>(d) Cold-water pressure from the mains.</p>	
<p>10. State average fuel consumption since last report, giving the percentage of ashes and kind of fuel used.</p> <p>If coal be used, give name of colliery whence obtained.</p>	
<p>11. General Remarks.</p> <p><i>NOTE.—Any repairs that have been done in the boiler-house since last inspection should be recorded here.</i></p>	

## ENGINES.

<p>12. Description of engines noting also maker's name, date of erection, diameters of cylinders, and length of stroke.</p>	
<p>13. When and by whom last examined.</p>	
<p>14. Did you examine the interiors of the cylinders, and if so, with what result?</p>	
<p>15. Did you examine the steam-valves, and if so, with what result?</p>	
<p>16. Did you take any indicator diagrams? If so, attach to this report, a set worked out, with full particulars noted—</p> <p>(a) State whether you consider the valves are properly set for the most economical working of the engine.</p> <p>(b) State whether you considered the indicator diagrams are satisfactory or not, and whether any difference in them is apparent. If so, what, in your opinion, has caused the difference?</p>	
<p>17. Are all stuffing boxes and glands kept properly packed, and steam-pipes free from leaks?</p>	
<p>18. What vacuum is generally maintained?</p>	
<p>19. Is the air-pump in good order? Give temperature of its discharges.</p> <p><i>Note.—The temperature should not exceed 115°.</i></p>	



## ENGINES—concluded.

20. Are the lubricants in use of good and suitable quality, and is a sufficiently large supply of all stores kept in hand?

21. General Remarks.

*Note.—All repairs, however slight, that have been carried out since last report, should be mentioned here.*

## PUMPS.

22. Description of pumps, noting also diameters of buckets or plungers, length of stroke, number and size of valves.

23. Did you examine all buckets and plungers, and if so, with what result?

24. What do you consider is the percentage of "slip"?

(a) What do you find the mechanical efficiency of the engines?

25. Were the pumps working smoothly, evenly and without noise, or banging of valves?

26. Are the air-vessels kept properly charged with air?

(a) State means of doing so.

27. General Remarks.

*Note.—All repairs that have been carried out since last report should be mentioned here.*

## GENERAL.

28. Is the staff at the pumping-station sufficient, and the health of the employes generally good?

29. General Remarks.

Signed \_\_\_\_\_

Date \_\_\_\_\_

Rank \_\_\_\_\_

A daily record of the receipts and issues of coal and engine-room stores should be maintained; and in this connection I should point out that the cost of the latter should never exceed between 9 and 10 per cent. of the former.

Hitherto I have only described to you what I might term permanent pumping installations, and being permanent they have to be capable of running for a number of years with the minimum expenditure of money in repairs, and of coal in raising and supplying steam. It may, however, so happen that you may require only a temporary installation of pumping machinery, say for supplying water to coolies building a bridge, or for dewatering a tank, in which case a pulsometer or a centrifugal pump comes in very useful.

The pulsometer consists, briefly, of two pear-shaped vessels cast together, the necks terminating in one chamber, in which two valve-seats are arranged, with one ball-valve which oscillates between them. Air-chambers, suction and delivery valves are also fitted. When the pump is charged with water steam is admitted, and pressing on the surface of water in one chamber forces it through the delivery valve into the delivery pipe. When the steam reaches the opening leading to the discharge it comes in contact with the water in the pipes and is immediately condensed, forming a vacuum in the chamber just emptied of water. This vacuum draws the valve-ball over to the seat opposite to that which it previously occupied, and prevents for the time being a further admission of steam. To fill the vacuum formed water rises through the suction-pipe and fills the empty chamber: this operation is repeated again and again, and with such rapidity that a nearly continuous stream of water is forced through the delivery pipe. There being practically no moving parts in this pump, wear is reduced to a minimum. The height of suction varies somewhat according to the size of the pulsometer, but it should be from 6 to 12 feet with the small sizes that you will have to deal with; but the actual total lift depends on the pressure of steam supplied; thus for lifts from 20 to 40 feet the pressure of steam should not be less than from 20 to 30 lbs. per square inch, and for lifts from 40 to 80 feet not less than 30 to 50 lbs. The pulsometer is well suited for raising water from out-of-the-way places, as it occupies but little space; one that will discharge 2,000 gallons per hour being only 23 inches high.

The centrifugal pump consists, as I dare say you know, of a series of curved blades mounted on a spindle and made to revolve very rapidly in a cast-iron case. The revolution of these blades produces a partial vacuum in the case, which, aided by the pressure of the atmosphere, brings up the water. For lifting a large quantity of water to a moderate height the centrifugal pump is unsurpassed, but it has this drawback, as far as we are concerned; it requires a steam-engine to work it, whereas the pulsometer only requires a steam-boiler. The design of centrifugal pumps has been so greatly improved within late years that they will draw water from a depth of 25 feet and force it another 50 or 60 feet; and if they are placed in series it is understood that water can be forced up to 500 feet. I have not had any experience with such pumps, but I have seen here in Calcutta a series that is guaranteed by the makers to pump up to 150 feet.

There are innumerable patterns of pumps always on the market, and no doubt it will cause you a great deal of confusion and uncertainty to ascertain the best pump. The only advice I can give you is, first and foremost, avoid all patent motions of valves, cylinders, pumps, etc.; at

present the best forms are those that have not been patented or whose patents have expired. In the second place, take the engine which is guaranteed to have the highest duty, and therefore the least coal consumption. And, thirdly, do not take a pump by an unknown maker or by a firm that will make you anything from a pin to a steam-hammer, for pump-designing and manufacture is a speciality.

### THE DISTRIBUTION OF WATER.

We now come to what I consider to be the most important part of these lectures, in so far as they deal with water-supply, and that is the distribution of the water which gives us so much trouble to collect and purify. And it will, I trust, be an interesting section of my lectures, because many of you no doubt have got your daily supply of water by one or other of the methods which I am proceeding to describe; you have an example of one system in the water-supply that is now laid on to this College.

All through these lectures you will have perhaps noticed that the subjects could be divided into two classes—intermittent and constant. I have explained to you the intermittent and constant systems of purification, and you have seen how even the rainfall is intermittent in tropical countries and constant in temperate climates, and so it is with the question of the distribution of water. In wells, tanks, and rivers the supply is a constant one, because it can be drawn upon at any time, but in large town supplies we can have either a constant supply or an intermittent one: in the former case the water is always available, whereas in the latter the water is obtainable only at certain hours, that is, while the pumps are at work. You have examples of the two systems close at hand: in Calcutta water is only to be had for certain hours in the morning, and again for a few hours during the afternoon, whereas here in Howrah you can obtain water at any hour of the day or night. When water-supply systems were first installed in England it was thought that less water would be used if it were only made available at certain hours of the day. In supplies that were pumped this, no doubt, was a convenience, because it prevented the engines being kept under steam continuously, and it therefore saved money for coal; but the matter was carried still further, for even with gravitation supplies from reservoirs the sluices were actually closed down during certain hours of the day and night to prevent the water reaching the consumers. But it never occurred to the projectors of these works that it would not suit the convenience of every consumer to take water at the same hour, and the result was that tanks or cisterns had to be constructed in every house which could be filled during the hours of supply and then kept for drawing on at the convenience of the inmates. Tanks and cisterns are not things of beauty, and the result was that they were erected in all sorts of odd places and corners, and when the water-carriage system of removing sewage came into vogue, the cisterns were made to serve a double purpose—that of supplying drinking and washing water and that of supplying water-closets. The result of this was the most insanitary practice of connecting water-closets directly with the cisterns. This system of private cisterns

or vats prevails in Calcutta, although care is taken that they shall not be connected with closets or latrines. The experience of recent years in England has amply proved that with a constant service of water in connection with a proper installation of what are known as waste-water meters, and to a careful and regular system of inspection of house-fittings, such as taps, etc., the consumption of water can be reduced to one-half what it was under the intermittent system, and with an undoubted improvement in the health of the consumers. Under the intermittent system taps are left constantly open, and as soon as the pumping engines cease working, pressure is reduced and the air rushes back through the taps into the mains to supply the place of the water—air coming perhaps from a cistern connected with a water-closet, or, as in many instances in Calcutta, air coming from near a filthy house drain, the contents of which are ever giving forth the foetid gases of putrefaction. In this country an intermittent system has another objection. Many, in fact, I may say most, of the consumers are poor people living in miserable huts and unable to afford the cost of a cistern or vat in which to store water, and a supply of water has to be kept in earthen *chattis*; should this meagre supply of water, by some mishap, be lost, the hard-working man coming to his home after the hours when water is supplied has to resort to the nearest tank or well for the water necessary for his evening meal. No care is taken as a rule of tanks or wells in towns where there are water-supplies, and consequently their water is of the filthiest and most polluted character, and numbers of the wage-earning portion of the community come to an early death from cholera, or, if it is not quite as bad as that, they are incapacitated from work by bowel-complaints, which in nine cases out of ten are due to drinking unwholesome water. You will thus see that the only safe and proper system of water-supply is one that provides for a constant service. In the comparatively recently-constructed works of the North-Western Provinces, which were originally designed for an intermittent supply, this has had to be acknowledged, and the necessary service reservoirs are now being constructed. The more recently-constructed works at Meerut, Howrah, Arrah, and Berhampore are designed for a constant service; and provision has been made in the new Calcutta Corporation Bill that is now under the consideration of the Bengal Legislative Council for the gradual introduction of a constant supply of water; and as soon as funds are available I hope to see the same system introduced in the other water-works in Bengal.

I must now explain how it is possible to have a constant service without keeping the pumps constantly at work. If we only had to rely on engines and pumps to do this, we should probably find that the saving in the cost of the water actually supplied would be less than the extra cost of keeping the engines working against a varying pressure, or, in other words, at a varying speed, for there is no more uneconomical method of working pumping engines than against a varying load; to get the highest economy, that is, the cheapest work, out of a pumping engine you must have a fixed load on the engine, that is, it must work at a constant speed, and the nearer this approaches the

maximum speed the better. But the conditions of demand of water prevent this completely, because the demand for water varies at different hours of the day. As a rule, the greatest demand for water occurs for four or five hours in the morning and again for three or four hours in the afternoon or evening; but water is required in between these periods, and if we had to depend on engines alone, we should have to make them work at full speed in the morning, at half or quarter speed during the day, then full speed again in the afternoon, and then half or quarter speed during the evening, and perhaps dead slow during the night. Pumping would therefore have to be continuous throughout the twenty-four hours, which would entail a very large engine-room staff, and the consumption of coal would be out of all proportion to the power developed, for the reasons that I have already stated, namely, that a pumping engine only gives the most economical results when it is being worked with a full load. I believe in some cases two different sets of engines have been provided—one set to meet the heaviest demand during the morning and afternoon, and the other to meet the small demand; this is an economical arrangement as far as the working of the engines goes, but it necessitates a very large initial outlay, which, in this country at any rate, is a thing to be avoided. In the case of the supply being derived from large tanks or reservoirs, no such arrangement is necessary, for the supply, being due to gravitation, is necessarily constant. It is not, however, always possible, more especially in this country, to get natural or semi-natural reservoirs at such an elevation as will enable us to make use of gravitation to force the water through the distribution pipes, and so we have to design our works, at any rate in the plains, so that the water shall be pumped up into an entirely artificial reservoir, and then allow it to gravitate into the pipes from which it can be drawn off by the consumer. Plate No. 9 gives the style of reservoir that is usually designed for this purpose: it consists of a circular wrought-iron covered tank supported on rolled joists resting on a brick masonry pedestal. The reservoirs are usually calculated to hold from one-third to half day's supply, but in my own practice I prefer the larger size. In many of the reservoirs of this design brick arches are substituted for the rolled joists to carry the bottom of the tank, but unless the two annular rings settle exactly the same amount these arches are likely to crack open, and, moreover, they are very difficult to build. Instead of a flat bottom a spherical one is sometimes provided for these tanks, and such a bottom requiring neither internal stays nor supporting girders may be supported on a single row of columns or piers or upon a tower. The only example of this design that I know of in India is the one that was constructed some two years ago at Umballa to hold 220,000 gallons; it is 58 feet diameter, and has a maximum depth of 19' 6" of water at the centre and 9' 6" at the sides. The cost was Rs. 48,738. Although this reservoir has been perfectly successful and has never given any trouble, I do not think that it is a suitable design for this country on account of the great care that has to be taken in getting all the plates of the spherical bottom properly bent to their correct shape, and further the weight on the foundations is probably greater than would be safe in this part of Bengal at any rate.

Yet another design are the water-towers that have been recently erected at Meerut, which consist of cylindrical shells of W. I. plate 25' in diameter and 34' high, supported on a masonry platform rising only 5 feet above ground level. Meerut City is built on an artificial mound, the highest part being some 40 feet above the general level of the country. The soil is so bad that it was impossible to build an ordinary raised reservoir in the City; to have built one large enough to meet the maximum demand with the pumps working continuously and only delivering the mean supply, would have, I am informed, cost Rs. 80,000 or a lakh. Two towers, each holding 100,000 gallons, only cost Rs. 30,000, so this design has at any rate the merit of cheapness and simplicity, but, I am afraid, it cannot be considered beautiful.

These service-reservoirs are kept supplied with water through a C. I main connecting them with the main pumps; and it is usual to so arrange the size of the main and the power of the pumps that the whole day's supply shall be pumped into the reservoir in about 10 hours. In some cases the pumping is continuous throughout the 24 hours, but it is not an arrangement that I favour much myself, because there is no room for the expansion of the works hereafter, and a comparatively large engine-room staff has to be entertained—nearly three times as many men as would be necessary for a system in which the water is delivered in 10 hours.

I think this will be an appropriate opportunity for me to explain to you the methods usually adopted for calculating the discharges through pipes, but in doing so I am going to assume that you already know all about the theory of the flow of water in pipes, what is the meaning of head lost in friction, and how the discharge is affected by the hydraulic mean gradient. There are numerous formulæ giving the discharges of pipes, but I believe it is generally accepted now that the Darcy formulæ for clean and incrustated pipes are the most reliable, because the co-efficient of discharge varies with the diameter and the roughness of the internal surface of the pipe. The co-efficient is expressed in the following terms, using English measures:—

$$C_c = \frac{113}{\sqrt{1 + \frac{1}{12d}}} \text{ for clean pipes} \quad \dots \quad (i)$$

$$\text{and } C_r = \frac{80}{\sqrt{1 + \frac{1}{12d}}} \text{ for rusted pipes} \quad \dots \quad (ii)$$

where  $d$  is the internal diameter of the pipe in feet.

Now according to Tudsbury and Brightmore "if  $d$  be taken a mean between one foot and four feet, the average co-efficient so found will yield results within the limits of sensible accuracy." The formula for the velocity of flow then becomes—

$$\text{For clean pipes } V = 55 \sqrt{di} \quad \dots \quad (iii)$$

$$\text{,, rusted ,, } V = 39 \sqrt{di} \quad \dots \quad (iv)$$

$i$  being the slope of the hydraulic mean gradient.

I have seen it stated that with the comparatively soft water of Bengal it is never necessary to make any allowance for incrustated or rusted pipes. I find, however, that the water supplied to Howrah and that which will be supplied to Berhampore is every bit as hard as that of London water. By using the formulæ for rusted pipes you also make allowances for losses of head at bends, elbows, etc., and for any unforeseen increase in the population, and in this latter connection I recently had a conversation with that eminent hydraulic engineer, Professor W. Cawthorne Unwin, on the subject, and he strongly advised the use of the formulæ for rusted pipes, and you cannot do better than follow that advice. For all pipes under twelve inches diameter a separate coefficient must be used in the formula:—

$$V = C_r \sqrt{\frac{d^5 h}{4l}}$$

or if  $Q$  = the discharge in cubic feet per second,  
 $h$  = loss of head in friction in feet,  
 $l$  = the length of the pipe in feet.

$$\text{Then } Q = 0.39 C_r \sqrt{\frac{d^5 h}{l}} \quad \dots \quad \text{(v)}$$

$$\text{and } h = \frac{l Q^2}{0.15 C_r^2 d^5} \quad \dots \quad \text{(vi)}$$

where  $C_r$  has the following values:—

Diameter.	$C_r$	Diameter.	$C_r$	Diameter.	$C_r$	Diameter.	$C_r$
Inches.		Inches.		Inches.		Inches.	
$\frac{1}{2}$	46.18	$1\frac{3}{4}$	63.83	3	69.29	8	75.43
$\frac{3}{4}$	52.41	2	65.33	4	71.57	9	75.90
1	56.57	$2\frac{1}{4}$	66.58	5	73.03	10	76.28
$1\frac{1}{4}$	59.64	$2\frac{1}{2}$	67.61	6	74.08	11	76.60
$1\frac{1}{2}$	61.98	$2\frac{3}{4}$	68.50	7	74.84	.....	.....

For pipes ranging between 1 foot and 4 feet the equations giving the discharge and the head lost in friction will be—

$$Q = 30 \sqrt{\frac{d^5 h}{l}} \quad \dots \quad \dots \quad \text{(vii)}$$

$$\text{and } h = \frac{l Q^2}{900 d^5} \quad \dots \quad \dots \quad \text{(viii)}$$

These are the formulæ that I always use, and I have always found them very accurate; for instance, on two occasions the observed discharges of the 4-inch main supplying the town of Darjeeling, which is upwards of 4 miles long, were 5,988 and 6,088 gallons per hour respectively, and the discharge calculated by the above formulæ is 5,962 gallons per hour. On another occasion the observed discharge of a

pipe was 4,084 gallons per hour as against 4,118 gallons calculated by the formulæ.

The maximum velocity of flow in the largest class of pipes is about three feet per second, but unless there is plenty of power available, it is very seldom that the velocity exceeds two feet per second. When power is supplied from steam-pumps you will have to consider whether for the mains supplying the service reservoirs it will be cheaper to have a pipe main of large diameter and a small engine, or a large engine and a small main; various formulæ have been proposed for the most economical arrangement, but there are so many circumstances to be considered that the only way to solve the problem is by actual trial and calculation.

We now have to consider the method of distributing the water, collected in the reservoir, to the actual consumer. This, as you are probably aware, is effected by means of iron standposts fixed at the sides of the streets, about 300 feet apart on an average, and by taps fixed inside the houses, known as house-connections. In the constant system the standposts and house-connections receive their water through service mains or distribution pipes connected with the service reservoir, whereas in the intermittent system the distribution pipes are connected directly with the pumps. Now, in designing a system of distribution pipes for a town it is not possible to say with any certainty where and when water will be required. When works are first designed the positions of the street standposts are decided by the Municipal Commissioners in meeting, but after the works have been opened it is generally found that more standposts are required in some districts, while in others the standposts are but little used; then, again, the richer people like to have the water laid on to their houses. Then it may so happen that every few minutes all the standposts and taps are discharging at the same time, while at others only half or a quarter of the number are open. Under these circumstances it is safer, I think, to assume that all the standposts, the positions of which have been decided by the Municipal Commissioners, are open at the same time. Bearing in mind that half the daily supply has to be discharged in four hours, you will be able to calculate the necessary discharge from each standpost, and using the formulæ given above, you will be able to decide the diameters of the pipes and the total head lost in friction. The minimum diameter of cast-iron piping that should be used in distribution systems is 3 inches; for diameters smaller than this the pipes have to be inordinately thick, and consequently much heavier in proportion to the quantity of water they carry. I have recently published a set of tables based on the Darcy formulæ which I have described to you above, and these will save much labour in calculating sizes of pipes, etc.

Now in the case of a constant service another element has to be introduced into our calculations, and that is the maximum height to which a reservoir can safely be built. As far as my experience goes, the base of the reservoir should not be more than 35 to 40 feet above ground level, and then if we allow 10 feet as the head of pressure at which the water is to be delivered at the standpost most remote from the reservoir or the pumps, the head available for forcing water through the distribution piping will be the height of the floor of the



reservoir above ground level less 10 feet, and this height divided by the length of the distribution main (omitting the branches) will give you the hydraulic mean gradient of the distribution main; if this is less than 2 or 3 per 1,000 in pipes below 6", and 4 or 5 per 1,000 in pipes above, then a second reservoir must be provided. A very ready method of designing pipe lines for approximate estimates is given below. The total length of distribution piping is scaled off the plan, and from this we can ascertain the discharge per 1,000 feet of the distribution piping. Then measure the length of the main distribution pipe as before from the map, and you will be able to ascertain the hydraulic mean gradient. The statement given below should be carefully worked out with the map of pipe lines given in plate No. 10 :—

BHADRESWAR.

RESERVOIR No. 6.

SOUTH DISTRICT.

Population = 10,000. Daily supply per head = 10 gallons. Total length of distribution piping = 20,295 feet.  
 Half daily supply in 4 hours =  $\frac{10,000 \times 10}{2 \times 4} = 12,500$  gallons per hour. Discharge of distribution piping per 1,000 feet =  $\frac{12,500}{20,295} = 616$  gallons per hour. Mean hydraulic gradient = 3.5 per 1,000.

Name of Street.	Main.	Branch.	Discharge in gallons per hour.	Diameter of pipe.
Grand Trunk Road ... ..	1,800	...	1,109 ... ..	3"
Ditto ... ..	260	...	1,109 + 160 = 1,269 ... ..	4"
Sirkar Bagan Lane ... ..	...	660	407 ... ..	3"
Grand Trunk Road ... ..	250	...	1,269 + 407 + 154 = 1,830 ... ..	4"
Majherpara Lane ... ..	...	300	185 ... ..	3"
Grand Trunk Road ... ..	600	...	1,830 + 185 + 370 = 2,385 ... ..	4"
Ditto ... ..	1,840	...	2,385 + 825 = 3,210 ... ..	5"
Station Road ... ..	...	580	358 ... ..	3"
Bhattacharjeepara Lane ... ..	...	1,120	353 + 690 = 1,048 ... ..	3"
Bassyapara Lane ... ..	...	150	1,048 + 92 = 1,140 ... ..	3"
Ditto ... ..	...	680	1,140 + 419 = 1,559 ... ..	4"
Grand Trunk Road ... ..	2,360	...	3,210 + 1,559 + 1,454 = 6,223	6"
Shitola Lane ... ..	...	370	228 ... ..	3"
Baruipara Lane ... ..	...	1,280	228 + 788 = 1,016 ... ..	3"
Brahmanpara Lane ... ..	...	160	1,016 + 99 = 1,115 ... ..	3"
Nootan Bati Lane ... ..	...	830	1,115 + 511 = 1,626 ... ..	4"
Patrapara Lane ... ..	...	660	1,626 + 407 = 2,033 ... ..	4"
Grand Trunk Road ... ..	400	...	6,223 + 2,033 + 246 = 8,502	7"
Total ... ..	7,010	6,790		

Head lost in friction = 3.5 × 7.01 = 24.5 feet.

## NORTH DISTRICT.

Name of Street.	Main.	Branch.	Discharges in gallons per hour.	Diameter of pipe.
Kamarpara Lane ... ..	580	...	357 ... ..	3"
Telinipara Ferry Ghat Road ...	1,250	...	357 + 770 = 1,127 ...	3"
Ditto ditto ...	2,050	...	1,127 + 1,263 = 2,390 ...	4"
Ditto ditto ...	1,900	...	2,390 + 1,170 = 3,560 ...	5"
Grand Trunk Road ... ..	...	540	333 ... ..	3"
Grand Trunk Road ... ..	590	...	3,560 + 333 + 303 = 4,256 ...	5"
Ditto ... ..	1,730	...	4,256 + 450 = 4,706 ...	6"
Total ...	7,100	540		

Head lost in friction =  $3.5 \times 7.1 = 24.85$  feet.

The pipe lines have been divided into two districts, and it will be seen that the pipe running along the Grand Trunk Road in the district south of the reservoir is the longest, and therefore should be taken as the main. The hydraulic gradient is 3.5 per 1,000, and the discharge of a 3-inch pipe with this gradient is 1,136 gallons per hour, but the discharge of the distribution piping is 616 gallons per hour per 1,000 feet, so that  $\frac{1136}{616}$  will be the length of 3-inch pipe that can be laid; the rest of the road up to the junction with Sirkar Bagan Lane must be laid with a 4-inch pipe. The length of this lane is only 660 feet, and so only  $\frac{616 \times 660}{1,000}$  gallons per hour is required for the supply of this lane, and a 3-inch pipe is quite big enough. Coming back again to the Grand Trunk Road, the pipe now has to carry  $1,269 + 407 = 1,676$  gallons per hour, plus an allowance of  $\frac{616 \times 250}{1,000} = 154$  gallons per hour for its own length, or 1,830 gallons in all. A 4-inch pipe with an hydraulic mean gradient of 3.5 per 1,000 will carry 2,393 gallons per hour, and so a pipe of this size will suit. And so we can go on gradually working up to the reservoir. Strictly speaking, this method is not absolutely correct for branches, and it makes the pipes rather too large, because no allowance is made for the gradual rise on the hydraulic mean gradient towards the reservoir. The true hydraulic mean gradient in Sirkar Bagan Lane is the head in the main at the point of junction divided by the length of the lane, that is,  $\frac{2,060 \times 3.5 \times 1,000}{1,000 \times 660} = 10.9$  per 1,000. Similarly, for the branch beginning in Shitola Lane, the hydraulic mean gradient is  $\frac{6,610 \times 3.5 \times 1,000}{1,000 \times 3,300} = 7.0$  per 1,000, and consequently 500 feet 3-inch piping might have been substituted for the same length of 4-inch piping. But the method I have shown you is quite near enough for approximate estimates. When the detailed estimates come to be made out you would have to calculate out carefully the hydraulic mean gradient of each main and branch.

You will observe on the plan that the full lines which indicate the pipe lines whose sizes and discharges have been calculated in the manner

I have just explained to you are joined together in many cases by dotted lines ; these dotted lines indicate the extra piping that should be laid down so as to promote the circulation of the water through the system, and thus avoid what are known as "dead ends," that is to say, the ends of pipe lines in which the water is dead or has no flow. Water that collects in "dead ends" is liable to become very unwholesome, and so they should be avoided as far as possible. If the end of the pipe-line is in a populous quarter, a standpost may be provided so that the water may be drawn off through it. If a stand-post cannot be erected, or if erected, remains unused, what is known as a scour-valve must be provided, so as to discharge a small quantity of the water at least every other day into the nearest drain or *nala*. The best plan of all, though, is to connect the "dead end" of one line of piping with that of another ; it adds slightly to the cost of the pipes, but it is by far the most satisfactory way of getting over the difficulty.

In the matter of designing extensions for existing water-supply systems, you must first of all ascertain, by means of a pressure-gauge, the average pressure during the hours of greatest demand in the distribution main from which the extension is required ; this is usually done by screwing the pressure-gauge on to the stand-post nearest to the proposed extension. From the average observed pressure you must deduct 10 feet for the residual head, which is always desirable, and the remainder will be the pressure available for forcing the water through the extension.

Now, as regards the thickness of the cast-iron pipes, you will find in all the text-books on the subject formulæ from which you can, if you have the time, calculate out the thickness of the pipes, and consequently their weights. But this takes time, and unless you have plenty to spare I should advise you to refer to the makers' catalogues and find what sizes and weights of pipes are to be had to withstand certain pressures, which are usually double the working pressures. Cast-iron pipes can now be had varying by  $\frac{1}{32}$  inch in thickness. Pipes from 3 inches to 12 inches in length are usually 9 feet long, exclusive of the socket, and from 12 inches upwards, 12 feet long. For ordinary pipe lines pipes with turned and bored joints have been found to be about the most convenient, but for suction pipes flanged pipes must be used, so that one pipe can be disconnected from the rest whenever necessary. In the former class of joints it is usual to make every tenth joint with lead, but every one of the latter has to be most carefully made with lead wire.

For turning round corners in the pipe line "bends" are provided, designated as a "quarter," "eighth" or "sixteenth" "bends," according to whether its circumference passes through the quarter, eighth or sixteenth of a circle. With pipes of small diameters, say up to 12 inches, all bends must be carefully leaded, but for pipes above that diameter, not only must the joints of the bends be leaded, but the bends themselves should be set in concrete, so as to prevent the thrust of the water, due to the change in direction of the motion, drawing the bend out of its joint. With very large pipes the thrust is so great that in addition to the concrete the pipes have to be anchored with large wrought-iron bolts on to the straight portions of the pipe line. For branches taking off

at right angles to the pipe line "special" pipes are made, ordinarily known as T-pieces, their name explaining their shape.

The accessories of a system of distribution pipes are (1) the sluice or stop-valves, (2) the scour-valves, (3) the air-valves, (4) the relief-valves, (5) the reflux-valves, but the time at my disposal will not permit me to explain these details. I must refer you to text-books on water-works engineering.

Now, as regards the standposts from which the water is actually drawn, there are numerous patterns to be had, but I have come to the conclusion that the Glenfield pattern is by far the best. In this pattern, in order to cause the water to flow, a knob must be turned and kept turned until sufficient water is drawn, because if it is let go a balance-weight inside the standpost causes the spindle to revolve, and so shut off the water. The push-cock pattern of tap is not very satisfactory, because pieces of bamboo can be wedged in between the push and the casing, thus causing the tap to run continuously, or it can be kept open by tying a piece of string round the post with a small stone just on top of the push. As a rule the tap should not be more than  $\frac{1}{2}$  inch diameter, because with heavy pressures the water comes out in too great volume from a tap of larger diameter, or, in the case of low pressure, it does not issue with sufficient velocity to shoot straight into the mouths of the water-vessels, whereby a great deal of water is wasted. Then, again, the standpost should not be too high, and in my opinion two feet is quite as high as the tap should be above the ground. This keeps the tap as near as possible to the water-vessel, and it further prevents people sitting under the tap and bathing, for as a rule we cannot afford to give filtered water for bathing purposes. The standpost should be erected on a small square masonry platform provided with a good slope towards the nearest drain, so that all the water that is wasted may be carried off as quickly as possible. The best and most efficient form of platform has yet to be decided.

When the owner of a house desires to have the water laid on to his house, what is called a house-connection has to be made. A hole is bored, with a special machine, in the distributing main, and a brass ferrule is screwed into the hole. The water is taken from the main, in wrought-iron pipes, either galvanized or coated with a special preparation of asphaltum, which are screwed on to the ferrule. Now in fixing the diameter of the connection pipe, you should first ascertain the quantity of water that the householder is entitled to for the amount of water-rates he pays; and the pipe will have to be large enough to carry half the day's supply in four hours. You must then ascertain the pressure available at the nearest standpost, from which you will be able to calculate the diameter of the pipe. It has been customary hitherto to try and regulate the quantity of water admitted into a house by means of the ferrule, but a ferrule is so short that the head lost in forcing the water through it is practically nothing to that lost in forcing the water through the connection pipe to the taps. Therefore decide the size of the pipe in the manner I have indicated and then use a ferrule  $\frac{1}{8}$ " smaller, or if the discharge in the pipe is very much in excess of the correct discharge, a ferrule  $\frac{1}{4}$ " smaller might be used. A stop-cock, with a surface box, must form part of the connection and should

be placed as close to the outside of the premises as possible, so that the supply may be turned off whenever necessary. In my opinion all water for house-connections should be sold by meter, that is to say, only the actual quantity of water taken should be paid for, at so much per 1,000 gallons.

I think perhaps it may be of assistance to you if I give you a sample form of general specifications for the works that I have described to you. I have made use of the following specifications, modified, of course, to suit various conditions, for some years now, and they have always been the means of producing satisfactory work :—

#### GENERAL SPECIFICATIONS.

1. All materials supplied and all works executed under this contract will be subject to the approval of the Engineer.

2. The sites of the head-works and the elevated reservoir will be handed over to the contractor as they stand, and the cost of clearing the ground for building operations must be borne by the contractor. The cost of all temporary land required for stacking materials, cutting earth, etc., etc., will be borne by the contractor. When the works are completed, the contractor will clear away all surplus and unused materials, brick, rubbish, etc., free of cost. The tender to include a kutchu-pucka wall with lime pointing, lime plaster coping, and one pair of iron entrance gates, round the site of the pumping-station.

3. Unless otherwise specified, all materials are to be of the best quality :—

*Bricks*—To be sound, hard, well-burnt, of good shape and uniform colour, and to measure 10" × 5" × 3".

*Lime*—To be obtained by burning clean kunkur in properly constructed kilns at the site of the work. All lime to be ground in a patent pulveriser. No lime that has been burnt for more than 14 days is to be used in the works.

*Surki*—To be made from well-burnt but not vitrified brick-bats, and to be perfectly clean and free from foreign matter. The brick-bats to be broken to pass through a ring 1½ inch in diameter, and to be ground up in a steam mortar-mill.

*Sand*—To be sharp, clean, river sand, rather coarse than fine, perfectly free from all admixture of earth or other matter.

*Khoa*—To be made from good sound hard brickbats and to pass through a ring 1½ inch in diameter; on no account are vitrified brickbats to be used for this purpose.

*Portland Cement*—Only the best English Portland cement to be used, and the contractor must state the name of the maker and the date of importation into India, but no cement that has been landed in India more than three months will be allowed to be used.

4. All concrete in these works to be composed of 100 parts of khoa, 20 parts of lime, and 40 parts of surki, of the qualities specified in paragraph 3; the khoa to be soaked in water for at least four hours before mixing. All the materials composing the concrete are to be thoroughly mixed in the dry state, and are to be turned over at least three times. Only sufficient water is to be used as will suffice to keep the materials damp. The concrete to be laid in courses of not more than six inches in thickness, and each course to be well rammed and consolidated with rammers weighing not less than 12 lbs.; while the concrete is being rammed, it should be sprinkled with water and kept constantly damp.

5. Lime mortar to consist of one part of lime and two parts of surki, of the qualities specified in paragraph 3. All lime mortar to be ground and mixed in steam mortar mill.

6. Cement mortar to consist of one part of Portland cement and two parts of sand, of the qualities specified in paragraph 3.

7. Unless otherwise specified, all brick masonry is to consist of bricks, as specified in paragraph 3, laid in lime mortar, as specified in paragraph 5. The bond used shall be English, and no more half-bricks or brick-bats shall be used than are necessary to complete the bond. In walls more than three feet thick, 20 per cent. of half and three-quarter bricks may be used. No bricks to be used until they have been thoroughly soaked in clear water for at least two hours, and all masonry in progress is to be kept constantly moist.

8. Cement plaster is to consist of one part of Portland cement and two parts of sand, as specified in paragraph 3.

9. Sand plaster to consist of lime and sand as specified in paragraph 3, in the proportions of one and-a-half parts of lime and two of sand.

10. All pointing is to be rule pointing, unless otherwise specified; the joints to be raked out to a depth of half an inch and filled flush with lime mortar, consisting of equal parts of lime and surki, carefully ground and strained.

11. All reduced levels shown on the drawings are referred to a datum which is feet above mean sea-level. The contractor will fix a permanent benchmark at the head-works, so as to enable any Engineer, deputed to inspect or supervise the work, to easily check the levels of work in progress.

12. *The intake.*—The intake is to be built strictly in accordance with the drawing. The river end of the pipe is to be provided with a cast-iron strainer, the aggregate area of the holes in which must be at least three times the area of the pipe. Where the pipe passes through the sides of the pump well or of the manholes, relieving arches must be built round it in order to take off as much pressure as possible. Step irons to be provided in the manholes to facilitate descent or ascent.

13. *Settling tanks.*—These are to be constructed strictly in accordance with the drawings. All trees and jungle and their roots must be entirely removed from the site of the tanks, and the ground on which the banks are to be constructed is to be thoroughly dug up and examined for a depth of two feet, and all roots of trees, remains of brick buildings, etc., etc., entirely removed. Before the new banks are constructed, this loosened earth must be thoroughly rammed and flooded with water to a depth of six inches for at least 24 hours. The earth for the embankments to be thrown up in layers not exceeding six inches in thickness, and each layer is to be thoroughly consolidated with iron rammers or heavy rollers; every alternate layer is to be thoroughly well flooded with water to a depth of at least six inches for not less than 24 hours. Care should be taken that all clods and large pieces of earth are entirely broken up. The slopes where not covered with masonry to be carefully dressed and turfed with good *dhub* grass.

The weirs are to be built strictly in accordance with the drawing; the foundation pits are to be dug with vertical sides, of the exact dimensions of the concrete; before the concrete work is commenced, the foundation to be carefully examined with a crow-bar for soft places.

The water will be drawn off from each tank through a wrought-iron revolving pipe; the end of the elbow-pipe and the inner surface of the gland to be faced with gun-metal. The centre piece or trunnion to be cast on the elbow-pipe and to rest in a cast-iron plumber block with gun-metal bearing. The mouth of the pipe to be covered with a galvanized-wire strainer, 5 meshes to an inch. A hollow float of galvanized sheet-iron, made watertight, with all arms and attachments for suspending the mouth of the pipe at the required depth to be provided.

14. *Filter-beds and clear-water reservoir.*—The filter-beds and the clear-water reservoir are to be constructed strictly in accordance with the drawings. The foundation trenches to be cut to the exact size of the concrete, and before any concrete is laid in the trenches they must be carefully examined for soft places with a crow-bar. All concrete, brick masonry and other kinds of work to be carried out as specified in paragraphs 4 to 10. The floor of the clear-water reservoir is not to be constructed until the centres carrying the arched roof have been struck and the earth-filling completed, but spaces must be left so that the floor may be bonded into the side walls; similarly, the floors of the filter-beds are

not to be constructed until the side walls of the filter-beds are entirely completed and bonded into those of the clear-water reservoir, and the floors must be bonded into the side walls.

The inside of the main drain to be plastered with  $\frac{1}{2}$ " cement plaster as specified in paragraph 8. The brick drains are to be constructed in the usual manner, and a special projection or fillet is to be built near the foot of the side walls, so as to provide an air passage between the ends of the drains and the ventilators.

The filtering material will consist of—

- 3" pebbles averaging  $\frac{1}{2}$ " diameter.
- 6" coarse sand similar to Magra sand.
- 24" fine sand.

The filtering material to be thoroughly washed in filtered water before being placed finally in the filters.

Relieving arches are to be built over all pipes passing through the walls, and the pipes are not to be fixed in position until the main body of the masonry is completed. The inside faces of the side walls and of the filter-beds and the interiors of the filtration wells to be sand-plastered, as specified in paragraph 9. The interior faces of the walls, the floor, and all sluices and pipes in the filtration wells to be painted with white silicate paint.

Gauges having their zeros at the floors of the filter-beds to be painted on the walls of the filter-beds and filtration wells. Floating gauges to be provided for the filtration wells, so that the filtration head may be observed without removing the cast-iron covers of the wells; a floating gauge is also to be provided for the clear-water reservoir.

The four manholes provided in the clear-water reservoir to be lined with white Raniganj glazed tiles or bricks, and they are to be covered with stone slabs set in lime mortar.

The earth-filling over the clear-water reservoir to be carefully dressed and turfed with *dhub* grass, and sufficient slope is to be given to the surface to prevent rain-water lodging or draining into the filter-beds.

15. *Sand-washing pit*.—The sand-washing pit is to be constructed strictly in accordance with the drawing and of the materials, and in the manner specified in paragraphs 3 to 10.

16. *Elevated reservoir*.—The elevated reservoir is to be built strictly in accordance with the drawings. The pedestal is to be constructed of the materials and in the manner specified in paragraphs 3 to 10. All wrought-iron in the structure to be well and cleanly rolled to the full sections shown in the drawings, and free from scales, blisters, laminations, cracked edges and defects of every sort. The shell of the reservoir is to be the best boiler-work. Rivet-holes may be drilled or punched at the option of the contractor, and the sizes and pitches of the rivets are to be those recommended by Unwin in "Machine Design," pages 117-118. For the sides of the tank, all joints are to be butt-jointed with double cover-plates, the horizontal joints to be single-riveted, and the vertical joints double-riveted. The iron plates in the roof and ventilator to be lap-jointed and single-riveted.

Where the ironwork of the shell is supported on masonry, asphalt  $\frac{1}{2}$ " in thickness is to be laid between the masonry and the ironwork.

Sufficient slope is to be given to the floor of the reservoir, so that water will flow readily towards the sludge-pipe.

The interior of the tank to be coated with two coats of Dr. Angus-Smith's composition, applied hot. All exterior ironwork to be carefully painted with two coats of stone-colour paint, laid over a coat of boiling linseed oil and a coat of priming, but before any ironwork is painted, it must be thoroughly cleaned and scrubbed with wire brushes, so as to remove all rust. A floating gauge, showing on an exterior gauge the depth of water in the reservoir, to be provided, as also an exterior staircase, and the necessary wrought-iron ladders for obtaining an entrance to the interior of the reservoir.

The spaces between the outside row of pillars to be filled with an ornamental wrought or cast-iron railing four feet high. A marble memorial tablet, with a suitable inscription recording the name of the donor of the water-works, etc., to be provided and fixed in a suitable position on the pedestal.

17. *Engines, pumps and boilers.*—The unfiltered water has to be lifted from the pump well under the engine-house to the level of the weirs in the settling tanks. The pump well is 15 feet in diameter, and the top of the concrete plugging is feet below the floor of the engine-house. The tender for the unfiltered water-engine to include the suction pipe in diameter with the usual strainer, and all wrought-iron beams necessary to carry the suction pipe, pump-valves, etc., and wrought-iron ladders to enable the suction pipe, pump-valves, etc., to be examined. The lowest known water-level in the river is above datum, and the crests of the weirs in the settling tanks are above datum. Allowing for friction in the delivery main, which is in diameter, the unfiltered water-engine is required to deliver gallons in hours, against a head, including suction, of feet. The level of the pump-valves must not be above above datum, that is, a little over feet above the lowest water level, and the floor of the engine-house is above datum.

The filtered water-engines, which will be in duplicate, must each be capable of delivering gallons in hours, against a total head, including suction, of feet. The suction pipe from the clear-water reservoir will be inches in diameter, and the delivery pipe inches in diameter. The bottom of the clear-water reservoir is above datum, and, as before noted, the floor of the engine-house is above datum.

18. The engines to be compound or triple expansion, rotary or non-rotary condensing engines of the most modern design and manufacture. All the steam cylinders to be effectually jacketted with boiler steam, and have efficient steam-supply and drain arrangements; they are to be thickly covered with non-conducting material and lagged with laminated planished steel-plates fixed with brass button-headed screws, lapped into the castings; no wooden lagging or lagging grounds will be allowed. All the cylinder covers to be covered with non-conducting material and to have bright false covers secured with bright delta metal set-screws.

The engines to be provided with steam and vacuum gauges, sight feed-lubricators, indicators with the necessary cocks and fittings, and all other fittings that are necessary and usually provided for the efficient and economical running of engines. Separate engines in duplicate to be provided for working both the air and boiler feed-pumps. The condenser to be of efficient type, and all steam and water-pipes, valves and connections for the same to be properly arranged. The temperature of the injection water may be taken as 90° Fahrenheit.

The engine-maker must state in his tender the duty in foot-pounds of water raised per 112 pounds of English coal, which he can safely guarantee will be obtained by the plant in actual useful work.

19. The pumps to be double-acting on both the suction and delivery sides. The filtered water-pumps to have numerous small valves on the Worthington or similar principle. All plungers to work in gun-metal barrels. Air- and vacuum-vessels, provided with gauge-glasses, to be fixed on the delivery and suction-pipes inside the engine-house; the air-vessels to be provided with apparatus for keeping up the supply of air, and the vacuum-vessels to be provided with snifting valves. Steam ejectors to be provided for the suction-pipes. Pressure-gauges to be provided and fixed on all delivery-pipes, and a Bristol's Recording Pressure-Gauge to be provided and connected with the filtered water main delivery-pipe. Ample manholes to be provided for access to the pump-valves. The pumps must be supplied with apparatus to ensure their making their full stroke, and recorders or counters recording the aggregate travel of the plungers, and not the number of strokes, to be provided.

The tender must specify and include all spare parts which the contractor may consider to be a fair provision against accident and wear. The price of those spare parts to be shown separately from that of the engines.

All pipes inside the engine-room to form part of the contract. A suitable clock for the engine-room to be provided.

20. A traveller, capable of lifting any part of the engine-room machinery, to be provided, as also the track rails and holding-down bolts. A detailed drawing of the track rails and holding-down bolts, together with a note of the total weights of the carrier and its heaviest load, to be submitted, so that the walls of the engine-house may be so constructed as to carry the extra weight.



21. The finish of the engines and pumps must be the best of its kind, all working parts being accurately machined, fair, square, and in line. Each part of the engines and pumps must be centred or have its exact position defined by turned grummets or planed edges, and not be dependent on the fixing bolts or on steady pins for that purpose. The engine shall be a bright engine in every respect, having all parts exposed to view, got up "bright," which are usually so finished by the best makers of water-works engines, and those parts not finished bright shall be carefully rubbed smooth and painted with two coats of good oil before shipment, and after erection painted with three coats of good oil-paint of an approved colour and two coats of copal varnish.

22. The boilers to be made of mild steel and tested according to the English Board of Trade Rules, allowing a factor of safety of 5. The boilers to be two in number, but each boiler to be capable of supplying sufficient steam for working the unfiltered and one filtered water-engine. The furnaces to be of dimensions suitable for burning Indian coal, which may be taken as two-thirds the efficiency of good Newcastle coal. The main steam-pipes to be carefully covered with non-conducting material and provided with expansion joints and the necessary stop-valves. Tenderers to state the height and area of chimney they consider necessary for the boilers.

23. Tenders to include delivery and erection at the site of the pumping station and maintenance for twelve months from the date of pumping water into the town; the cost of maintenance, which should be shown separately, to include the cost of coal, stores and labour necessary to run the engines, and it should be shown separately from the cost of the plant. The Engineer will also expect a guarantee against breakdowns in ordinary working for three years from the termination of the period of maintenance. Each tender to be accompanied by a full detailed specification and drawings, sufficiently illustrating the same. One set of exact tracings on cloth of all the working drawings to be supplied to the Engineer.

24. Payment for the engines and boilers will be made thus:—

Sixty per cent. on the engines, etc., etc., being delivered at site of works.

Thirty per cent. after erection and being worked satisfactorily under steam for eight hours continuously.

Ten per cent. at the close of the period of maintenance referred to in paragraph 23.

25. *Pipes and sluices.*—The pipes are to have turned and bored joints, with a taper of 1 in 40, universally applicable to all pipes of the same size. Provision to be made in all pipes for an external lead joint, and a groove is to be cast in each socket to prevent the lead coming out; lead joints, however, only to be used in bad ground and in curves in the pipe lines.

All the straight pipes mentioned in the above schedule must be cast in England or Scotland; bends, specials and irregular castings may be cast in India, but in either case the name of the maker must be quoted in the tender.

The pipes to be cast vertically in dry sand-moulds with the sockets downwards. They are to be of uniform thickness of metal throughout, free from scoriæ, sand-holes, air bubbles, cold-shuts, laps, washes and other imperfections of casting, and shall be truly cylindrical in the base, straight in the axis, smooth within and without, internally of the full specified diameter, and they shall have their inner and outer surfaces perfectly concentric.

The metal shall be made from mine-pig, without the admixture of cinder-iron or other inferior metal, and shall be stout, tough, close-grained, and shall be re-melted in the cupola.

Bends, specials and other irregular castings must not be of greater thickness than the straight pipes; every care to be taken that these pipes shall make a perfect joint with the straight pipes and other castings with which they may be intended to connect.

When the radius of a curve in the pipe line is less than 480 feet, special bend pipes must be used. On the main between the pumping station and the elevated reservoir, when special bend-pipes have to be used, they must be anchored in blocks of concrete, and in the case of quarter bends, anchor bolts must also be used.

All pipes to be carefully coated internally and externally with anti-corrosive composition, according to Dr. R. Angus-Smith's process. The coating to be applied to the pipes while they are at a proper heat, and as soon as possible after they are cast, and before any rust sets in.

All pipes to be tested by hydrostatic pressure, equal to a column of water 300 feet in height, and whilst subject to such pressure, to be repeatedly struck all over with a hammer 5 lbs in weight, to discover whether there be any defects in them. The testing to be done at the foundry at the contractor's expense.

Each pipe, bend, special, and irregular casting to have cast upon it the letters and the figures 1897 in Roman letters and numerals  $1\frac{1}{2}$  inches high; also the thickness of the pipe in numerals 1 inch high; all letters and numerals to be  $\frac{1}{8}$  inch projection.

The permitted deviation in weight and dimensions is 2 per cent.

The total lengths of pipes given in the report are believed to be correct, but the Engineer can accept no responsibility in respect of this.

The tops of pipes not to be less than 2' 6" below the road surface, and before the pipes are laid the spigots and sockets must be cleaned with iron bushes until bright.

26. Sluice-valves to be of the most approved manufacture, with gun-metal spindles, nuts and faces. Each sluice-valve to be tested by hydrostatic pressure, equal to a column of water 300 feet high. In testing the double-faced valves, each side to be tested.

Stop-valves are to be provided at all depressions in the pipe lines with scour-valves on each side of them; the necessary branches for carrying off the water into the nearest drainage channel to be provided. Air-valves to be fixed at all summits of the pipe lines and provided with air-pipes where necessary.

All valves to be right handed, that is to say, the lever or arm is to follow the hands of a watch when the sluice is being closed.

The reflux-valves to be fitted with a number of small flap-valves, the aggregate area of which must be  $1\frac{1}{2}$  times that of the main pipe on which the reflux-valve is fitted. Ample manhole area to be provided for the proper examination of the flap-valves.

27. All street stand-posts to be of approved pattern; all cocks to be strong and self-closing, no brass work is to be used externally, and no lead work internally. Two pressure gauges to be provided for taking pressures at stand-posts. Stand-posts to be fixed on masonry platforms, and proper provision is to be made for draining the platform and contiguous road and foot-path.

28. The water-meters on the main pipe lines to be provided in duplicate with the necessary sluices, bye-pass and mud-boxes.

29. The pipe lines, &c., to be maintained, and all defects made good at the expense of the contractor, for a period of twelve months, dating from the time water is pumped into the mains by the new engines.

30. The sludge drain to be of Raniganj pipes of the diameters shown on the site-plan and laid on concrete; the pipes to have cement joints. Suitable manholes with cast-iron gratings to be provided at all changes of direction and diameter.

31. *Houses for establishment.*—These are to be built strictly in accordance with the drawings and with the specifications in force in the Public Works Department.

32. The contractor whose tender is accepted will be required to maintain the works in running order for a period of twelve months, commencing from the date the engines first pump water continuously into the elevated reservoir; the contractor will supply all labour and material necessary to maintain the works, and the cost of this maintenance to be shown separately from the cost of the works in the tender.

33. Two complete sets of drawings, showing the works as actually executed, to be provided by the contractor, whose tender is accepted, before the final payment is made.

And now, gentlemen, as far as time has permitted, I think I have brought to your notice most of the points of water-supply that demand your attention. I have taken you to its original source, the

sea; then we have come and found it as it appears on the land again as rain, and issues from the earth in the form of springs and rivers. Then I have shown you how it has to be examined for quality and quantity, and if these enquiries prove satisfactory, how it can be collected, purified, and then distributed to the consumer. This one subject of water-supply has taken up a great deal of our time, but this is not a matter of regret, seeing what an absolute necessity for the welfare of the human race good water is. This course of lectures is now drawing to a conclusion, and I have still to address you on three other subjects, which, however, are of a much simpler character than the one that has now been brought to a conclusion. I find that in Mr. Jones' book on sanitary engineering 200 pages are devoted to water-supply, 8 to surface drainage, 38 to conservancy, and 10 to roads, or, in other words, water-supply takes four times as long to explain as all other subjects put together.

---

### DRAINAGE.

I explained to you in my first lecture the reasons I had for considering that a wholesome water-supply was of great importance for the welfare of the community, and I pointed out that we cannot sleep and live either in damp houses, or in dry houses with damp surroundings, without our healths being impaired, and that therefore an efficient drainage system must form part of our sanitary scheme. In most, in fact I may say in all, text-books on the subject, the word drainage is used with reference to the conveyance and removal of rain-water, and the liquid wastes of houses by means of underground pipes or channels, a drain being defined in the English Public Health Act, 1875, as "any drain of, and used for the drainage of, one building only, or premises within the same curtilage, and made merely for the purpose of communicating therefrom with a cesspool or other like receptacle for drainage; or with a sewer into which the drainage of two or more buildings or premises occupied by different persons is conveyed." In this country, however, where sewered cities are the exception, drainage means practically the removal of liquids, whether resulting from rain or household wastes, in channels cut or laid nearly on the surface of the ground; these channels are called surface-drains, but generally drains for short. It is on this Indian interpretation of the word drain that I shall base my remarks, because time will not permit of my addressing you on the somewhat intricate subject of sewerage, and moreover questions of surface drainage will have to be decided wherever your work may take you, whereas you are only likely to have to deal with underground sewers in the Presidency towns like Calcutta, Bombay, or Madras. For all questions of house-drainage and sewerage, I must refer you to such a book as "Sanitary Engineering" by Colonel G. E. S. Moore, R.E.; it has only just been published, and will no doubt supply a long-felt want, as Mr. Baldwin Latham's classical work on the same subject has long been out of print and unobtainable.

Now, let us consider for a minute the necessity and evolution of surface drains in a town or village. The question of the drainage of large tracts of country or agricultural drainage need not enter into our calculations at all, for it is based on entirely different data. In small villages or collections of huts no special arrangements have to be made for carrying off the rain that falls, because most of it soaks into the ground, while the balance goes off as quickly as may be to help to swell the volume of the main drainage channel of the district. The inhabitants of a village thrive and prosper, and the necessity for additional houses springs up. Now in all villages in the plains the village road, or as it sometimes is merely a footpath, is generally to be found on the highest land, for the simple reason that the users like to walk dry-shod for as long as possible during the rainy season. Owners of houses and shops find it more convenient and lucrative to be close to a road or path that is much frequented, and consequently the additional houses required by the increasing population will be built by the sides of the most frequented road. A town or village whose houses are built along two or three or more short and perhaps parallel roads is infinitely more convenient than one with houses along one long road only, and consequently houses will spring up on the next highest ridge or footpath at some little distance perhaps from the main road. We thus have two or more ridges, very often running parallel to each other, upon which rain falls and from which it runs off, and consequently between these ridges there are always lines of lowest levels into which the rain-water from the surrounding roads finds its way; these are what we may call the natural drainage channels as opposed to the artificial channels which are usually the excavations at the sides of the roads from which earth is obtained to replace the material washed and blown off the roads. We have thus two sets of drains—those running at the edges of roads, and those running at some distance off and receiving the drainage from the roadside drains. There is yet a third class of drain connected with the drainage of a town or village—the main outfall drain—into which all the drainage water falls and by which it is carried right away into the nearest river.

If the drains of a town had to deal with the rainfall only, they would even then get silted up, and the water would not flow off quickly and efficiently, and the town would remain damp longer than it should; it is therefore necessary to construct our drains in some methodical manner and on some previously determined plan, and see that they are properly maintained. In European countries, before systems of under-ground sewers were introduced, the side drains were also used as the receptacles for all the liquid, and in many cases the solid wastes of houses; and it is the same in this country now, and the result is that if arrangements are not made for a proper drainage system these are left putrefying by the sides of the roads, thus rendering the surrounding air most obnoxious and unhealthy.

From your lectures on hydraulics you have learnt that of two channels of the same section and slope, the one with masonry, and perhaps cement plastered sides and bed, will carry a much greater discharge than another which has been only cut in the ground, and is even obstructed with trees and their roots, etc.: consequently for the same

quantity of water a masonry channel can be made smaller than an earthen one. All land at the sides of roads is very valuable, and very often also that inside the blocks, as the land bounded on all sides by roads may be called, and so, if only on this account, surface drains must in most cases be constructed of masonry. But there is another much more important reason: even in the rains the liquids carried by the drains of a town are of a very foul and impure character, and they are of course ten times more so during the dry weather; we must therefore endeavour to carry away these offensive products from the neighbourhood of inhabited houses as quickly as possible. I have frequently been asked whether earthen drains have not the advantage over masonry drains in having the surrounding earth to be brought into play as a deodoriser and absorbent; in my opinion such a contention is based on the most erroneous and vague ideas as to the principles by which organic matter, such as is found in roadside drains, can be dealt with by earth and purified, and you yourselves have only got to look at the filthy and offensive state of many of the earthen drains in Howrah to be convinced that there is evidently something inefficient in such drains, and that the surrounding earth acts neither as a deodorant nor an absorbent. In towns whose water-supply is derived from wells, this filtered liquid filth must eventually find its way into the sub-soil water in the neighbourhood of the wells, and thus pollute it to most serious extent. There is yet another reason against this perpetual pollution of the soil with organic matter, for the recent experiments of Drs. Sydney Marsden and Robertson have clearly shown that it is one of the chief factors in the prevalence and the spread of typhoid fever. These observers found that, by taking certain soils containing a certain amount of organic matter, that is to say, organically polluted soils, the typhoid fever organism, when introduced into the soil, lived for 456 days; whereas in soil containing no organic matter it could only live for from 14 to 25 days. I am most decidedly of opinion that all drains within urban limits should be quite impervious, and should be so constructed and maintained that they can carry off, with the least possible delay, all the liquid wastes to a place where they can be neither a nuisance to the senses nor a danger to the public health.

Before going into the details of the design and construction of a drainage system, I think I should point out to you wherein such a scheme differs from that for a water-supply from a financial point of view. You will have understood from what I have told you about water-supply that the whole scheme must be carried out in its entirety before water is obtainable from the standposts, or, in other words, it cannot be constructed piece-meal. Now, with a drainage scheme the state of affairs is quite the reverse, and there is no necessity at all to carry out the whole scheme at once; having got your scheme prepared and sanctioned, it is quite possible, you will see for yourselves, to construct as many drains each year as your finances will permit, remembering always that the drains at the lowest levels should be constructed first, so as to be ready to receive water coming from a higher level. There is still another point of difference between these two most important sanitary systems, and that is that a water-supply system is capable

of conferring very tangible benefits on the population served, and it can earn money by taxation for benefits received; but the immediate advantages of a drainage system are not brought so prominently to our notice, and further it can earn no money under the existing municipal machinery, the cost of construction and maintenance having to be met from the general fund.

For designing a drainage scheme it is necessary to have a map drawn to a large scale, on which can be shown the levels of existing roads and drains, but the majority of the municipalities in Bengal appear to be unable to afford even a little extra expenditure on this account, although the cost only amounts to Rs. 300 or Rs. 400 per square mile. In the absence of an accurate map the only thing to be done towards the improvement of the drainage of small impecunious municipalities is to employ gangs of coolies during the rains to remove obstructions to the free flow of water. Municipal Commissioners individually could do much good in this direction, because each of them could take charge of one or more gangs and supervise their work. This system of gang clearance was tried with a great degree of success in Alipore some five or six years ago, and I believe myself that it is the only one applicable to small municipalities.

You will best understand what information should be shown on surveys required for the preparation of projects for surface drainage by a perusal of the following instructions which I issue to surveyors engaged on works of this sort:—

*Instructions to Surveyors engaged in making surveys for drainage works.*

In ordinary cases, if a detail map of the municipality is not available, a prismatic compass survey is sufficient. The survey need not show all houses in detail, but thickly populated parts should be roughly surveyed in, also any large or important buildings, and all houses or huts abutting on to the roadside, especially if they are in a continuous line. It will be sufficient to only just survey in the front of such houses without the exact depth or width.

2. The width of the roads, drains, etc., can be ascertained from the chain line by offsets, and it is very necessary that the chainage should be accurately and carefully done, and the points of intersection of all roads carefully noted in the field book.

3. The levels should, in all cases, show road, ground, drain and sluice floor levels. It is enough to take the level of the centre of the drains, a note being made in the level book of its top and bottom widths. These levels should ordinarily be taken every 200 feet, but intermediate levels may be necessary according to the nature of the ground.

4. Cross-sections are needed showing the actual width of road, drain and position of houses, if there are any, on the roadside. These sections should be continued as far as possible inside bustees and the land lying between the roads, so as to show the general level of the country. If it is not possible to continue the cross-sections at right angles to the road owing to the existence of houses, a deviation should

be made or intermediate sections run, where openings occur, so as to get some interior levels. Cross sections that extend into the interior may be taken 400 feet apart. Ordinarily the cross sections should be taken every 200 feet unless the land has a uniform slope or is fairly level, in which case sections at every 400 feet would be sufficient.

5. All low land lying between roads to be carefully levelled and noted, and houses on it to be surveyed in, and position noted, so that it may be seen if it is possible to run a drainage channel there if such is necessary.

6. Sizes of all culverts to be carefully noted and entered on the plan. The width of the opening should be placed first, and height generally taken to springing of arch.

7. All existing drainage channels should be carefully surveyed, levelled over, and cross sections taken. Main outlet channels should be surveyed and levelled over to their outfall into some drainage khal, river, or low-lying jheel away from the town.

8. Levels of any low land on the outskirts of the town in which it is likely a main outlet channel may be made, if one is not already existing, should be carefully taken and a survey made of it.

9. All work to be carefully done, and mainline of levels checked by releveling over the line, unless it can be checked by means of fixed and trustworthy bench-marks. Subsidiary level lines to be checked by checking on to bench-marks on the main line.

10. No erasures on any account to be made in the level books, and all such books used to be submitted for inspection of a superior officer. Entries to be made directly into the books in the field. The reduced levels may be deduced afterwards to avoid waste of time.

If any large difference is found in the levels after a check has been made, the work must be done over again till the mistake is found and rectified.

11. Plans to be plotted to a scale of 16 inches to a mile. Sections to a vertical scale of 10 feet to an inch. Horizontal scale 16 inches to a mile. Cross sections to a natural scale of 10 feet to an inch.

As soon as the map has been plotted and the levels marked on it, the next step is to divide up the whole area into drainage blocks, that is, into small areas, the water from each of which falls into a separate drain or channel. This can be done roughly from the levels marked on the map, but it is a far better plan to go over the ground with the map in your hand and mark down, from local enquiry, the lines of highest levels which, you will understand, form the boundaries or water-sheds of each drainage area. As a rule, the roads being on the highest ridges, the roadside drains will be of the smallest size compatible with ease in cleansing, and they will discharge into the larger channels lying inside the blocks, as I have already described. In many of the older cities of Bengal, such as Patna, Dacca, etc., this state of things has been rather reversed, and the water from the interior of the block flows into the roadside drains; this condition of affairs has been brought about, first, by the raising of the ground for building purposes; secondly, by the collection of earthy matter, or filth heaps which become earthy matter, near houses, and very often by the falling down of mud huts which are not rebuilt again for some years.

Having settled the boundaries of the drainage blocks, we must now determine what quantity of water has to be removed. A surface drainage system is generally designed with a view to carrying off the rain-water only, but in towns unprovided with sewers they carry off a good deal more than this, namely, the liquid wastes of a house, *i.e.*, urine, bath water, and kitchen or cooking water. However, these liquid wastes are but a fractional part of the rainfall, and so they may be neglected as far as the designing of the size of the drains is concerned. If all drains had to be made large enough to carry off all the rain directly it fell, or, in other words, if the rain over a town or district fell direct into the drains, they would have to be of very large dimensions, but you will see for yourselves that this is impossible. If this page represents a drainage block with the drain running along the right hand edge, then of course all rain falling close to the edge of the drain will reach the drain much sooner than the rain that falls in the middle of the block or at the extreme edge of it. Another factor which regulates the quantity of water which drains have to carry away is the character of the ground in which the rain falls. If you have two tennis courts with identically the same slope, but one made of cement and the other of grass, the rain will flow off the former almost at once, and moreover will be greater in quantity than that from the latter, because cement is practically impervious when compared with grass or turf. Similarly there is not only a much larger quantity of drainage water coming of the roofs of the houses forming a town than from the fields of a rural area, but it also reaches the drains more quickly. You will understand, of course, that the rate of discharge of rain water off a hilly or mountainous area is very much increased, not only by the nature of the ground, but also by the increased rainfall due to the elevation.

The rainfall of a district varies with its situation, physical configuration and altitude, and the direction of the prevailing winds. I give below a statement of the average annual rainfall for each of the districts in Bengal:—

*Table showing normal annual rainfall in each district in Bengal.*

District.	Rainfall.	District.	Rainfall.	District.	Rainfall.	District.	Rainfall.
Backergunge ...	83.46	Darbhanga ...	49.74	Malda ...	56.88	Puri ...	58.14
Balasore ...	60.05	Darjeeling ...	137.07	Manbhum ...	53.11	Purnea ...	71.63
Bankura ...	56.10	Dinajpur ...	62.69	Midnapore ...	59.64	Rajshahi ...	56.20
Bhagalpur ...	51.53	Faridpur ...	65.86	Monghyr ...	47.40	Rangpur ...	82.27
Birbhum ...	57.12	Gaya ...	42.09	Murshidabad ...	53.72	Saran ...	44.94
Bogra ...	64.79	Hazaribagh ...	53.23	Muzaffarpur ...	45.80	Shahabad ...	42.52
Burdwan ...	54.15	Hooghly ...	57.29	Mymensingh ...	85.70	Singhbhum ...	54.07
Calcutta ...	61.49	Howrah ...	57.15	Nadia ...	57.24	Sonhai Parganas ...	52.71
Champaran ...	55.10	Jalpaiguri ...	120.79	Noakhali ...	115.14	Tippera ...	75.42
Chittagong ...	111.34	Jessore ...	59.76	Pabna ...	61.18	24-Parganas ...	62.33
Cuttack ...	60.50	Khulna ...	65.30	Palamau ...	49.00		
Dacca ...	71.96	Lohardaga ...	53.00	Patua ...	44.52	Average for Province.	63.94

The above table has been compiled from the report of the Sanitary Commissioner for Bengal for 1897.



The average rainfall, you thus see, varies from a minimum of 42·09 inches per annum at Gaya to 137·07 inches in Darjeeling, while the average for the whole province was 63·94 inches. You will notice that the average rainfall becomes gradually less the further west of the Bay of Bengal the district is; and also that districts near the Himalayas have greater rainfalls than those more remote.

At Patna and Muzaffarpur, where the annual rainfall is less than that of Calcutta, an allowance of only  $\frac{1}{8}$ th inch per hour has been made for fixing the sizes of the drains; but many of the drains in the urban area of Patna have been found to be too small, and have had consequently to be enlarged; at Muzaffarpur the allowance of  $\frac{1}{8}$ th inch appears to be ample, but there are many large tanks in the town area which act as moderators or regulators of the rainfall, which is not the case at Patna.

In the surface drainage of the suburban area of Calcutta an allowance of  $\frac{1}{4}$ " per hour has been provided for, but it must be remembered that 20 per cent. of the area consists of tanks, and further that the area is semi-rural. Speaking generally, I should be inclined to recommend that for all towns lying west of Burdwan the allowance of rainfall to be removed by surface drains should be  $\frac{1}{4}$ " in urban, and  $\frac{1}{8}$ " in rural, areas, while for those towns to the east of Burdwan, and including the district of Purnea, I think double the above quantities should be calculated for.

As regards the best form of channel for urban areas, we must remember that during the rainy season the drains will be running very often quite full, whereas during the dry season of the year there will be merely a trickle of water running down them. If a drain or channel is to be clean and inoffensive, the velocity of flow of all water in it must be such that it will scour away and carry off all impurities and filth that may be deposited therein. From your lectures on hydraulics you will have learnt that a circular channel or pipe has to be more than half full for the maximum velocity to obtain, and further that when it is less than half full the mean velocity diminishes very rapidly. In a rectangular channel the differences in velocity are still greater. The only form of channel that will give a fairly constant velocity, whether it is quite full or only, say, a quarter full, is that known as Jackson's Peg-top section. I give on Plate No. 11 a series of drains of this pattern which were designed for the Patna drainage scheme. They have acted remarkably well, and they also have the advantage of being cheap. You see that each consists of a bed of concrete and two sloping side walls, the whole inside surface being plastered with cement. In making the smaller sizes of drain the first three inches of concrete is first laid and consolidated, a row of flat bricks is then laid along the centre line of the drain, and the rest of the concrete is rammed in position; the bricks are then removed, and a recess is left in the concrete, which can be easily formed to the required circular section by means of a little concrete and plaster. For the side walls it is necessary to have cut bricks, but this is rather an advantage than otherwise, because it gives a good rough surface for the cement plaster to adhere to. The discharge of these channels can be

conveniently calculated, without any appreciable error, from Bazin's formula (Type 2, for cut stone, brickwork, planking mortar)—

$$V = \frac{1}{\sqrt{0.0000579 \left( \frac{r+0.23}{r} \right)}} \sqrt{r \cdot s.}$$

where  $r$  and  $s$  are the hydraulic mean radius and slope respectively, or Kutter's formula with a coefficient of  $n = 0.012$  may be used if preferred.

The majority of the old drains in towns are either rectangular or trapezoidal, and they are generally unplastered. The former section is a particularly difficult one to keep properly clean, as the sharp corners cannot be cleaned, more especially if the drain is deep and narrow. The saucer-shaped drain is also another favourite shape; it is certainly more easily and effectually cleaned than either the rectangular or trapezoidal sections, but it is not self-cleansing when it only has a small depth of water in it, because the base is much too broad.

Main outfall channels pass mostly through the rural area of a municipality and may be more economically made of earth, but care must be taken that the junction of the town masonry drains with the outfall earthen channel is well removed from any dwellings, because during the dry season a large quantity of filth and decomposing organic matter is brought down by the town drains, and a nuisance is more often than not created at the point of junction, for the earthen channel being pervious absorbs the drainage water rather more quickly than it can convert the offensive organic matter into unoffensive inorganic compounds. For these channels Bazin's formula (Type 4 earth) may be used, thus:—

$$V = \frac{1}{\sqrt{0.00008534 \left( \frac{r+4.1}{r} \right)}} \sqrt{r \cdot s.}$$

or Kutter's formula with  $n = 0.030$  may be preferred; for comparatively small channels such as drainage channels usually are, I think Bazin's formula gives more accurate results.

There is one point in designing drainage channels, or in fact any channels carrying water, to which I would invite your attention, and that is the value of  $s$  in the above formulæ. Remember that it is the slope of the *water surface*, and not that of the *bed of the channel*. I have seen so many mistakes made in this matter that I think I must warn you about it. It has a special reference to junctions of drains with drains or drains with rivers; the water in major drains, when running full, will back up the minor drains, and that in rivers in flood will back up outfall drains and interfere with the free discharge. Therefore in designing a drainage project always work with water levels, and not bed levels. The minimum mean velocity, which will make drains and sewers self-cleansing, that is, which will cause the water flowing in them to carry off solid matter, is  $2\frac{1}{2}$  feet per second.

You should therefore design your drains so that the fall in the water surface will give this mean velocity. If the slope of the bed of a drain is such that the drain, when running full, *i.e.*, when the slope of the bed is the same as the slope of the water surface, will give a mean velocity greater than 3 feet per second, it is advisable to raise the bed by means of concrete, for no advantage is gained by having a higher mean velocity than 3 feet per second, and there is the disadvantage of the water surface towards the end of the drain falling lower than is actually necessary.

It will be many years yet before any of the mufassal municipalities in Bengal will be able to afford a system of underground drains and sewers such as we have in Calcutta, and that being so, it is very necessary that the surface drains such as I have described to you should be kept as open drains and not allowed to be gradually converted into covered drains by the encroachment of roadside buildings. No surface drains can be kept properly clean unless they are open to inspection and examination throughout their length. You all know how these encroachments begin just with a wooden plank for the owners of houses to walk over, then perhaps a series of planks which cover up the drain; the planks are exchanged for a wooden platform, and this in its turn makes way for a masonry *chiboutra* or verandah. In one town that I know of, the encroachments had been so extensive that the old original roadside drains were discovered running under the inner rooms of the row of houses which now form the boundary of the street. In my opinion a flight of steps, three feet wide, is sufficient for all requirements of ingress and egress, and not one inch more should be allowed. At Monghyr, where the encroachments on the drains have been notorious for years past, the owners have been compelled to break down the solid fronts of the verandahs and substitute a series of arches so that the drain is practically an open one.

Another objection to the covering over of surface drains is that they become the receptacle for the street sweepings which the conservancy establishment are perhaps too lazy to remove; often and often have I seen the road culverts practically filled up with this offensive matter. It is therefore equally necessary that all road culverts should be of ample size to permit the passage of a man or boy right through them. Raniganj pipes are hardly suitable for the culverts of town surface drains, unless they are of large size, and then they become very expensive. If there is sufficient depth below the roadway, brick arch culverts can be constructed to carry the drainage across roads, but in the majority of cases such is not the case, and then it becomes necessary to use stone slabs: these should not be set in mortar, for then it will be possible to lift them periodically and examine the inside of the culvert.

In designing culverts and crossings under roads you should always assume that the slope of the water surface will have to be twice what it is in a straight open drain, so as to allow for the head lost in changing the direction of the water. In any large culverts or bridges that may have to be built over the main outfall channel, it will probably be more economical to contract the area and increase the discharge, but you must remember that increased velocity means increased head or hydraulic mean slope, or, in other words, the water

must be slightly headed up in order to produce the increased velocity. A heading up of 3" will not as a rule cause any inconvenience, and this is sufficient to give a theoretical velocity of 4.00 feet per second.

Experience has shown that in all towns where masonry drains have been and are being constructed, it is very necessary to make some provision for their daily flushing, otherwise they become very offensive by reason of the amount of filth that is thrown out of the houses into them. It used, it seems to me, to be supposed that a drainage system in a town was much the same as an agricultural drainage system, and that its only function was to carry off rain-water quickly, but as a matter of fact I really believe that the surface drains carry off throughout the year much more liquid in the shape of urine and sullage water than they do rain-water. It seems, too, to be quite impossible, in remote parts of the town or in the back streets or gullies, to prevent the drains being used for promiscuous defæcation, so that in many cases the surface drains are really nothing more or less than open sewers carrying off the strongest possible sewage, and much stronger than one ever sees in England or other European countries, instead of being, as they were originally supposed to be, channels to carry off inoffensive rain-water. If, therefore, the drains are to be kept clean and wholesome, they must be thoroughly flushed daily; whilst sprinkling water in the drain, followed by sweepers raising clouds of filth with their brooms from the drain, are of no good, and to my mind are sheer waste of money. The proper way to flush and cleanse a drain is to divide into lengths of, say, 100 or 150 feet, according to whether it has a steep or flat slope, by means of pieces of board fitted into grooves cut in the sides of the drain. The first length should be filled with water as high as possible, and then if the board is suddenly removed the impounded water will go forward with a rush and carry off in front of it all objectionable matter that has been deposited in the drain. The second length can be filled from water from the first length and treated in the same way. When the flushing boards are lifted, sweepers with a compact bunch of straw or grass should be standing at the head of each length, ready to stoop down and push the water in front of them; this increases the velocity of the water and also pushes forward into a heap large lumps of solid matter too heavy for the water to move. Sweeper-boys seem rather to enjoy work of this kind. Speaking generally, two such flushes in the day are ample, but it is desirable that they should be sent down one after the other—the first one to carry off the heavier matter, and the second to take away what has been left behind by the first flush. You will naturally ask where is all the water to come from in towns that have no water-supply? This no doubt is a difficulty, but it can be surmounted in this way. In Eastern Bengal the towns have numerous tanks from which water can be raised into water-carts holding, say, 300 gallons each, or if there is a river at hand, water can be taken from it; the carts can be taken to the summits or highest points of the drains and half the contents used for each flush. In the towns of Bihar wells are frequently found at the roadsides, and if small masonry vats are provided, these can be filled by any of the means that I have already described, and then if the water is suddenly released, it will flush down the first reach of the

drain. A system similar to this is now in use at Patna, and is answering admirably, so much so that if the drains are not flushed regularly every day, petitions are put in at once to the Chairman, reporting the neglect of duty on part of the Inspectors and sweepers. The benefit of having drains flushed daily has been so completely recognized in Patna that it has been found necessary to lay down a system of cast-iron pipes and erect a small pumping engine to flush the drains in those localities where wells are not available. This scheme is the first of its kind in Bengal, and is more or less on its trial, and so I will not give you the details of it; if you should ever have to design a scheme of this kind, you will know where to go to see one in operation, although I am hoping that this small scheme is only a temporary arrangement, only to be used until the introduction of a water-supply to the whole town for all purposes, but still when that much-to-be desired time comes, I have no doubt the flushing of the drains will be conducted in the same manner. The flushing water from drains is of high manurial value, and a demand for it is rapidly arising in Patna for the irrigation of vegetable gardens, and you will hear, from what I have to say to you on the subject of conservancy, that there is no better method of disposing of this water than letting flow over cultivated land where it is quickly absorbed and decomposed into innocuous matter.

---

### CONSERVANCY.

The most unpleasant, but at the same time a very necessary, part of a Municipal Engineer's duties, is supervising the removal of the solid and liquid refuse and wastes of a town. I explained to you in my first lecture how these objectionable matters were, in villages, generally deposited in the surrounding fields and were then disposed of and rendered innocuous in a perfectly natural manner, that is, by the action of the air, the sun and the soil; but how that in a town or large collection of people special arrangements had to be made for their removal as soon as possible after they had been produced, and for their destruction in a cheap and effective manner. In large towns like Calcutta or Bombay this branch of municipal work is generally in charge of a Health Officer, who is a medical man, that is to say, as far as the collection is concerned, while the Engineer is responsible for its conveyance and disposal. In small towns, such as we have here in Bengal, the work is supervised by the Engineer or Overseers.

The wastes that I have referred to above may be divided into three classes—

- (a) Street-sweepings, which will include stable litter and the droppings of horses, cows, and other animals; vegetable refuse, such as plantain stalks and skins, decaying fruit and vegetables; leaves of trees and plants; and ashes and cinders.
- (b) Liquid wastes of a household, such as urine and cook-room and ablution water.
- (c) Solid wastes or nightsoil.

The system in vogue in most towns in Bengal for the removal of *street sweepings* is for them to be collected in heaps on the road, and then bullock-carts come round and collect them. The garbage and house-refuse are generally kept in the houses all day, and then thrown out on the roads in the early morning. In some municipalities corrugated iron dust-bins standing on small masonry platforms are used, and it is intended that householders shall bring their refuse and deposit it in them; theoretically this is a very perfect method, but in actual practice it is very difficult to get the householders to do their duty, and they much prefer to throw the refuse on to the road outside their doors, and further, the dust-bins themselves become centres of offensive smells unless they are kept scrupulously clean, and this is a most difficult matter where water is scarce. And so at present we must, I think, put up with the present system until the people themselves begin to understand the elements of sanitation. The ordinary country-cart, even when it has a specially made box on it, is, to my mind, hardly suitable for this sort of work, because street sweepings are very light, and consequently it is not possible to get a full load for a pair of bullocks; in my opinion it is always more economical to have specially constructed carts, such as one sees in Calcutta, of a capacity large enough to give a fair load to one bullock. In some municipalities I have seen very large carts of this pattern drawn by two bullocks, but this is not conducive to quick removal, for with a single cart and a pair of bullocks you can work from one end of the beat only, whereas with two carts with one bullock each you can work from both ends. It is not possible, of course, to get the bullock-carts into all the alleys and gullies of a town, and for the cleansing away of the sweepings of the houses situated in such localities I would recommend the use of galvanized iron hand-barrows; they are cheap, and if strongly made and the sweepers are made to take care of them, they last a long time and cost but little for repairs, which when they become necessary can be executed by the ordinary *mistri* that is found in mufassal towns. These barrows are also very useful for the collection of the filthy solid matter that finds its way into roadside drains. As a rule the sweepers who are cleaning the drains just simply lift up this filth and throw it in heaps on the road, where it is promptly scattered by dogs or birds on the look-out for garbage, and also by passing carts and carriages, and the result is that it is trodden into the road instead of being properly removed. It is a common thing in most municipalities to see a series of small lumps along the edges of the drains which look like earth, but which are in reality the remains of scrapings from the drains that have been thrown on the roadway and there allowed to remain. Sweepers cleaning drains should invariably be accompanied by another sweeper with a barrow. On no account should the scrapings from the drains be thrown anywhere else except into the barrow.

The best method of disposing of street sweepings is to utilize them in filling up tanks and hollows where water accumulates during the rains. In England they are burnt in what are known as incinerators. The heat so generated is used to raise steam for driving electric lighting and other machinery; this method of disposal is, however, unsuited to Indian conditions, because the street sweepings in this country contain such very much larger quantities of green vegetable matter and very

much less quantities of cinders, so that the heat that is generated is absorbed in driving off the watery constituents of the vegetable matter until practically none is left for heating the boilers. Vegetable matter is produced from the soil, and consequently its natural method of disposal is to return it to the earth, where it will again form soil for the growth of more vegetable matter. Now, if the sweepings are used for filling up tanks, care must be taken that the water in that part of the tank which is to be filled is baled or pumped out, because if sweepings are thrown into water, they become a most intolerable nuisance. It is therefore best to fill up tanks and hollows in the urban districts of a town during the dry season only; during the rains the sweepings should, I consider, be deposited in rural areas only, where they will cause less nuisance. It is an easy matter to calculate how many cart-loads of sweepings are required to fill a given tank, and if it takes more than are available during the dry season, the tank should be divided into two portions by an earthen "band"; the water need only be baled out from the portion to be filled with sweepings, and the rest of the tank can remain over until the next season. If the quantity of water to be baled out is not very great, the whole tank may be dewatered, and then earth for the "band" can be obtained from the bed of that portion of the tank that is not being filled in, and then it will only be necessary to build up a comparatively thin "band" of sufficient thickness to retain the sweepings in position, and also to protect them as far as possible from the water that will rise in the unfilled portion of the tank during the rains. If plenty of earth is available, a good plan is to cover each day's deposits, which will of course be generally made in the morning, with a thin layer of earth, as it greatly assists the decomposition of the vegetable matter, and further acts as a deodorant. If but little earth is available, then the best plan is to bring small portions of the area to be filled up to full level at once, and then cover them with a thin layer of earth and plant them with gourds, which are very quick-growing plants and require little or no cultivation; after gourds Indian-corn may be sown with advantage during the rains. In any case, whether earth is to be had or not, seeds of some sort should always be sown on the fresh deposits, as they hasten the decomposition of the vegetable organic matter in the street-sweepings. Tanks which have been filled with street-sweepings must not be built on for at least seven years.

The *liquid wastes* of a municipality consist, as I have said, of urine and the cooking and ablution water of households, and roughly speaking they amount in quantity to the daily water consumption. In towns that are provided with a water supply the quantity is easily ascertained, but in towns not so provided it is very difficult to give any exact figures, more especially as so much of the liquid wastes are allowed to either soak into the ground in the vicinity of the houses or else run into the cesspools in the courtyards or compounds. In Europe the quantity of urinary discharge is estimated at 40 ounces, or 2 pints per head; in tropical climates, however, I am inclined to think that this is rather too high an estimate; for although perhaps the consumption of water is higher than it is in temperate climates, larger quantities of liquid are discharged from the body in the form of perspiration,

It is the duty of every body of Municipal Commissioners to provide a certain number of public urinals, although I am much afraid they are but little used; they should, however, be provided, because then the public have no valid excuse for promiscuous urination. All that is required is a small brick platform with a receptacle underneath it for collecting the urine; the platform should be surrounded on three sides by sheets of corrugated iron, say three feet high, for the sake of decency. As regards the receptacle, this should be of metal (a kerosine oil tin) and provided with two handles, so that it can be easily moved. In private houses the urine is sometimes run into the vat or cesspool containing the cook-room and ablution water, or else it is mixed with the nightsoil or fæces, but more often than not it is allowed to flow with the other liquid wastes into the nearest public drain or water-course and is an offence to both the eyes and nose. The receptacles from the public urinals and private houses are supposed to be emptied daily into ordinary nightsoil carts, and the liquid wastes are carted out to the trenching ground and buried—at least they are supposed to be, but I am inclined to think that a very small proportion is actually disposed of in this manner, for the temptation to throw the liquid into the nearest ditch is generally too great to be resisted. The problem of the satisfactory disposal of the liquid wastes of a municipality has not been finally solved, although I am glad to say that we are, I think, within measurable distance of it. The great difficulty is the quantity combined with the offensiveness of the material. Time will not permit me to tell you the history of the experiment that has been going on in various municipalities during the past year or eighteen months; all that I can tell you is that the experiment consists of trying to deodorize and render the liquid wastes innocuous by filtering them through cinders. In England it has been found quite possible to dispose of town sewage by this method, and there seems to me to be no reason why we cannot dispose of the liquid wastes only of towns in India in the same way. The process is so simple and inexpensive that it should be tried in every town in Bengal. The liquids are collected in buckets or in a cart, and then poured into a bed or tank of cinders three or four feet deep into which they should be allowed to sink, so that no liquid is visible on the surface; the liquids are kept in contact with the cinders for some six or eight hours, and then the cock or sluice fixed at the bottom of the tank is opened, and the contents allowed to escape into the nearest *nala* or stream. If the liquid wastes do not contain any antiseptics like phenyle or carbolic acid, and do not consist of undiluted urine, it will be found that they will leave the filter practically odourless and colourless. The results of the experiments that have been made up to the present have been very encouraging, and I hope in another few months to be able to frame a set of rules showing exactly how the purification is to be carried on, and it will then be possible to save the cost of carting and disposal outside the town. For a further description of this process I must refer you to my pamphlet on the "Recent Methods of Sewage Disposal in England."

The *solid wastes* consist, as I have said, mainly of human fæces or nightsoil, and it is the regular collection and satisfactory disposal of



these that must ever claim the earnest attention of any one connected with sanitation of a town, whether he is a medical officer, an engineer, or even a private individual. Now, the nightsoil of towns that are not provided with sewers is, as you are all probably aware, deposited in the first instance in public latrines or in private privies, whence it is collected in nightsoil carts and taken outside the town, where it is usually buried in trenches.

As regards public latrines, these can be easily controlled, and if they are of a good pattern, well ventilated and carefully cleaned every day, they need never be a source of nuisance or danger to the public health. Until within the last few years these municipal institutions have not received the care and attention they demand, and the result is that in most towns in Bengal the public latrines consist of evil-smelling, badly-built structures thrust away in dark and confined corners where they are a nuisance to everybody, with the result that the people will not use them willingly. The mistake had always been made of allowing both the urine and the solid fæces to fall into one receptacle, and further of making the latrines much too large. Thanks to the inventions of Mr. Donaldson, we are now able to obtain a pattern of separation latrine which is eminently satisfactory, and I am of opinion that for India this pattern of seat is the only correct and truly sanitary one. Plate No. 12 shows the latest design for a one-seated latrine; the foot-rest, you will observe, is made of stoneware, but cast iron does equally well if kept well tarred, and is possibly cheaper; glazed stoneware, however, is practically impervious, and should therefore be used if possible. Under the foot-rest are two receptacles—one for the urine, and the other for the solid fæces. Experiments are now going on as to whether it would not be possible to arrange for the urine to be voided on to a small bed of cinders, so as to deodorize and purify it sufficiently to allow it to be run off into the nearest *nala* or drain; but they have not been going on quite long enough for me to say authoritatively that the receptacles for urine can be done away with. Now, as regards the number of seats that should be provided in public latrines in crowded quarters, I consider that a latrine with a large number of seats is a great mistake; it means that the people have to come greater distances to use it, and so may be tempted, or may even find it necessary, to deposit their nightsoil in places not intended for the purpose, and further, that a large latrine must be greater nuisance than a small one by reason of the greater quantity of deposits. I would much prefer to see two five-seated latrines than one ten-seated one, for I am sure they would be much more convenient to the users and quite as easily kept clean. Separate latrines must of course be provided for males and females; for the latter I always recommend that the partitions be of such size that the users can see each other, otherwise it is very difficult to get females to use public latrines. The floors of all latrines should consist of brick masonry smoothly plastered; they can then be kept clean by being flushed with water every day.

With the actual building of privies you will, as a public official, have nothing to do, but you may often be called upon either to design or to give an opinion on a proposed privy, and what I have said about public

latrines above will also apply to privies in private houses. I have recently framed a set of model bye-laws for the construction of privies which I will now read to you, as perhaps you may find them useful hereafter:—

### RULES AS TO PRIVATE PRIVIES AND URINALS.

*See Section 350c. (B.C.), Act III of 1884.*

Sec. 241.  
(Municipal Act.)

1. (1) No privy shall be placed in the space required by this Act to be left at the back of a building—

- (a) unless the total height of the privy does not exceed eleven feet, and
- (b) unless there is a space of at least four feet between the nearest wall and the service aperture of the privy.

(2) No privy situated in, or adjacent to, a building shall be placed at a distance of less than—

- (i) six feet from any other building which is a public building, or
- (ii) four feet from any other building which is, or is likely to be, used as a dwelling-place, or as a place in which any person is, or is intended to be, employed in any manufacture, trade or business.

2. No privy shall be placed on any upper floor of a building.

3. (1) If there is no convenient access from a street to any privy, the Commissioners may, if they think fit, by written notice, require the owner of the privy to form a passage giving access to the privy from

Provision of access to  
service privy from street.

the street.

(2) Every notice served under sub-rule (1) must require that such passage be formed at ground-level, be not less four feet wide, and be provided with a suitable door, and must inform the said owner that the passage may, at his option, be either open to the sky or covered in.

4. Models and type-plans of privies and urinals, approved by the Commissioners, with estimates of the cost of constructing privies and urinals in accordance therewith, shall be kept in the Municipal office, and shall be open to inspection by any person at all reasonable times without charge; but no person shall be bound to construct any privy or urinal in accordance with any such model or type-plan if the same be constructed in accordance with the other rules contained in this Schedule.

5. (1) A drain must be provided for every privy and every urinal.

Drain.

(2) Such drain must be constructed of some impervious material and must connect the floor of the privy or urinal—

- (a) with a drain communicating with a municipal drain or sower, or

- (b) if permitted by the Commissioners, with an impervious cesspool, the contents of which can be removed either by hand, or by flow, after filtration.

Floor. 6. (1) The floor of every privy and urinal—

- (a) must, if the Commissioners in any case so direct, be made of one of the following materials to be selected by the owner of the privy or urinal, that is to say, glazed tiles, artificial stone or cement, or
- (b) if no such direction is given, must be made of thoroughly well-burnt earthen tiles or bricks plastered, and not merely pointed, with cement, and
- (c) must be in every part at a height of not less than six inches above the level of the surface of the ground adjoining the privy or urinal.

(2) The floor of every privy and every urinal must have a fall or inclination of at least half an inch to the foot towards the drain prescribed by rule 5.

7. The walls and the roof (if any) of every privy and urinal shall be made of such materials as may be approved by the Commissioners;

Walls and roof.

Provided that—

- (a) in the case of privies, the entire surface of the walls below the platform shall either be rendered in cement or be made as prescribed in clause (a) or clause (b) of rule 6.

8. The platform of every privy must either be plastered with cement or be made of some watertight non-absorbent material as prescribed in rule 6.

Platform.

9. Every privy situated in, or adjacent to, a building must have an opening, of not less than three square feet in area, in one of the walls of the privy, as near the top of the wall as may be practicable and communicating directly with the open air.

Ventilation of privies in, or adjacent to, buildings.

10. Every privy must be constructed in accordance with the following provisions—

Receptacles for sewage.

- (a) the platform must be provided with two apertures so arranged that solid and liquid excreta can fall into separate receptacles placed underneath, as provided in the following paragraphs:
- (b) the space beneath the platform of the privy must be of such dimensions as to admit of two moveable receptacles for solid and liquid excreta, each of a capacity not exceeding one cubic foot, being placed and fitted beneath the platform in such manner and position as will effectually prevent the deposit, otherwise than in such receptacle, of any sewage falling or thrown through the apertures of the platform;
- (c) the privy must be so constructed as to afford adequate access to the said space for the purposes of cleansing such space and of placing therein, and removing therefrom, proper receptacles for sewage;

- (d) the said receptacles must be watertight, and must be made of metal if the capacity is over half a cubic foot or of well-tarred earthenware or glazed stoneware if the capacity is less than half a cubic foot ;
- (e) the door for the insertion and removal of the receptacles must be made so as to completely cover the aperture.

11. (1) If any privy or urinal erected or re-erected after the passing of these rules is so constructed as to contravene any of the provisions of this Schedule, the Commissioners may, by a written notice, whether or not the offender be prosecuted under the Municipal Act before a Magistrate, require—

Enforcement of the foregoing rules in the case of future privies or urinals.

- (a) the occupier of the building to which the privy or urinal belongs, or
- (b) (if the privy or urinal does not belong to a building) the owner of the land on which the privy or urinal stands,

to make such alterations as may be specified in the notice with the object of bringing the privy or urinal into conformity with the said provisions.

Nightsoil is collected from latrines and privies in either earthen *chatties*, wooden or sheet-iron buckets, hand-carts, or bullock-carts, depending on the accessibility of the privy. Earthen *chatties* are most objectionable, and should only be permitted as receptacles in privies under the circumstances given in the model bye-laws above, because, firstly, they are very porous, and the nightsoil simply soaks into them, and, secondly, they are very fragile and liable to be broken with the risk of spilling the nightsoil; even if the *chatties* are well tarred, they are still open to the latter objection. In my opinion by far the best means of collecting nightsoil from privies is in wooden buckets of the shape of a frustum of a cone and fitted with a wooden top or cover; if they are well tarred inside and out, they are quite inoffensive, and further they stand the hard wear and tear to which they are subjected much better than a bucket made of iron. The only reason that I know of for using iron buckets is that they can be made with rounded bottoms, and can thus be carried on the shoulder instead of on the head, for I must tell you that a *dhomes* or sweeper will not carry nightsoil buckets on his head, whereas a mehter will, but this caste prejudice should be overcome by making the *dhomes* carry the two buckets by means of a *banghi*, as is done in Calcutta. For the collection of nightsoil from privies which abut on narrow lanes or gullies, the best form of receptacle is an iron bucket holding about 12 gallons mounted on wheels; a bucket of this size can be easily lifted by a couple of men, and as soon as it is full it can be wheeled off to a depôt or fixed point where a specially constructed iron bullock-cart carrying eight or ten of these buckets is waiting to receive it. All that has to be done then is for the sweeper to wheel his full bucket to the depôt where it is exchanged for an empty bucket for use in another circuit or district, and the bullock-cart, as soon as it has got its full load, is taken off to the trenching-ground, where other

hand-barrows are waiting to receive the buckets and wheel them off to the trenches. In broad roads in which a bullock-cart can travel the night-soil can be taken from the privies or latrines and deposited direct into an iron cart, and so taken off to the trenching-ground. The best pattern of cart is what is known as the revolving cart, one in which the body revolves round the axles, and thus tips its contents straight into the trench. Plate No. 12 shows the cart that is found to work best in Calcutta; the shafts should be made of wood; shafts of rod iron have been tried, but there is too much spring in them, and they are apt to gall the bullocks. Each cart holds about 90 gallons. Care should be taken that the carts are thoroughly washed inside and out daily, and this remark applies to all receptacles used for the carriage of nightsoil; for unless this is done, they not only become a nuisance, but the acid in the decomposing fæces corrodes the iron. If iron carts are kept properly washed, they are found in Calcutta to last three years without requiring any repairs whatever.

Now, as regards the methods of disposal of the nightsoil that has been collected. The universal system, I think I may say, in Bengal, is by burying in trenches or pits. In Calcutta, Bombay and Madras, cities provided with underground sewers, the sewage and nightsoil are discharged into rivers and thus carried out to sea; in some up-country cantonments the nightsoil is burnt in incinerators; but, taken as a whole, I think burying in trenches is the system that is most suited to municipalities in Bengal, where the income is so small compared with the amount of work that has to be done. It is only within the last few years that the trenching of nightsoil has been carried on, on what I may call, scientific principles; the idea seemed to be in old days that as long as you buried the nightsoil in pits, however deep, nature would do the rest, but the science of bacteriology has shown us that the natural earth is only capable of rendering nightsoil innocuous within the top three feet at the most, and further that it cannot decompose and break down into innocuous compounds an unlimited quantity of nightsoil in a short time. The trenches should never be cut deeper than eighteen inches at the very outside, and they should never be filled with more than six inches of nightsoil. If these dimensions are adhered to, the cultivation of the trenching ground can be proceeded with almost immediately, and this above all things assists in the destruction of the nightsoil. In Bengal the advantages of cultivating trenching-grounds are only now beginning to be universally appreciated, and in many municipalities quite a large income is being derived from the leasing out of those grounds, and I am quite sure that in the near future the incomes will be very materially increased. I must say one word in regard to the selection of the sets for trenching-ground; it is a somewhat difficult matter, because the chief considerations are that the distance that the nightsoil has to be carried is not too great, and that the ground should be remote from habitations to which the process of trenching would be a nuisance. There is, however, one much more important point, and that is that the ground must not be subject to inundation during the rainy season; in fact, it must be at least five feet above highest known flood level; the reason of this is that nature's process of destruction cannot go on in water or in very damp ground.

Therefore if no such land is available, the sites must be raised artificially. The time at my disposal for these lectures will not permit me to explain to you the recent discoveries in the methods of sewage disposal that have been made within the last two or three years in England, but I may tell you that experiments are now being carried out by the Government of Bengal with a view of ascertaining whether these methods cannot be applied to the conditions that exist in India, and if these are successful, much of the trouble and expense of the satisfactory and safe disposal of nightsoil of municipalities will be done away with. I must again refer those of you who wish for further information on the subject to my pamphlet on the subject of sewage disposal.

---

### ROADS.

We have now arrived at the last item on the list of subjects that I told you I should try and deal with in these lectures, and that is the subject of the construction of new roads and the repair of existing ones. As a Municipal Engineer or Overseer you will be called upon not to align or lay out roads in new country, but merely to repair and keep in order existing roads, improve and widen existing lanes, and, perhaps, metal what are known in this country as *kutchu* roads; and you will, of course, be responsible for keeping existing bridges in good order, and very often to build new bridges or rebuild old ones, but this is a subject on which you have already received instruction, and so I need not refer to it in these lectures. In order to give you some idea of the materials that are used for the repair and maintenance of roads with which you will have to deal in these provinces, I asked the Chairmen of the various municipalities in Bengal to inform me what each of them used for the purpose, and from the replies I have received I find that the following are used—(1) stone metal, (2) laterite, (3) kankar, (4) brick khoa, and (5) quartz and laterite gravel; I propose to say a few words on the properties of, and the method of applying, each.

The best *stone* for road-metalling is one that is compact, durable, and tough, but it must not be too hard, or it will probably be too brittle, and will thus be quickly worn away by traffic. The basaltic trap of the Rajmahal Hills is undoubtedly the most satisfactory stone to use for road-metalling purposes on this side of India; it is the stone that is used in Calcutta, and I know of no better indigenous stone. At seaport towns it is very often possible to get the stone from ships coming from Bombay or Mauritius in ballast, and this as a rule makes a most excellent stone for road metal; but unfortunately the supplies are not regular and continuous, otherwise it is preferable to the Rajmahal stone, as it makes a much smoother road and wears as far as I know equally well. For a new road the bottom or foundation layer of metal may consist of stone broken to pass through a ring  $2\frac{1}{2}$  inches diameter, but for the upper working layer the pieces should be small enough to pass through a ring only

$1\frac{1}{2}$  inch diameter. The stone metalling on a road should never be less than  $4\frac{1}{2}$  inches in thickness, but where the traffic is very heavy, it must be at least 6 inches in thickness.

*Laterite* is a soft argillaceous stone of a red colour, and it makes excellent roads for light traffic, but it is rather too soft for heavy bullock-cart traffic to wear well; however, it is largely used in the districts where it is found, as it is easily quarried and easily consolidated. For a new road a thickness of 5 inches of pieces from  $1\frac{1}{2}$  to  $2\frac{1}{2}$  inches in diameter is generally laid. The variety known as nodular laterite should not be used, as it does not bind well.

*Kankar* or ghooting is a material that is well known to you, and so needs no description by me. It makes an excellent road, and should be laid down in two layers, each  $4\frac{1}{2}$  inches thick. The upper layer should be carefully washed and screened, so as to free it as far as possible of the yellow clay which is always found with kankar, but which is of no good for road-metalling purposes.

*Brick khoa* or broken brick is used in by far the greater number of municipalities in Bengal, because in most places it is obtainable locally. Nothing but well burnt bricks should be used for its manufacture; vitrified or *jhama* bricks may be used in small proportions, but on no account should unburnt or *pila* bricks be allowed, because, being soft, they are easily worn away, and the road quickly becomes uneven. The bricks should be broken up so as to pass through a  $2\frac{1}{2}$ " ring, and should be laid in two layers of 3 inches each.

*Quartz and laterite gravel* are used mostly in towns in Chota Nagpur. I have not had any experience of the wearing qualities of these materials, but quartz is a very brittle substance, and therefore not at all suitable for roads; however, it is very hard, and, being obtainable close at hand, is probably the cheapest; for, although it may not last long, large supplies are obtainable, and the road-metalling can easily be renewed.

Now, as regards the making of a new road of the materials I have described above, the first step is to make the formation level; this should not be made level transversely, as is so often done, but should be shaped so as to allow any water that percolates through the road metal to run off at the edges. A slope of 1 inch in 3 feet both ways from the centre of the road will be found to be sufficient for this purpose. On the formation level one or two layers of whole bricks laid flat should be provided, according to whether it is a road with light or heavy traffic; if two layers are provided, the top layer should break joint with the lower layer; if blocks of stone are available they may be laid flat, that is with the lines, at stratification horizontal. The metalling is then layed on this soling in thicknesses that I have already described, and then it should be rolled or rammed, but preferably the former. After the rolling has been completed,—and here I should say that every part of the metalling should be gone over at least three times—a layer of binding material, such as sand, sifted old building materials, laterite gravel or *kankar*, not more than one-quarter of an inch thick, should be laid; as much water should be poured on as to cause a small sea of mud in front of the roller, and then the whole

should be thoroughly rolled again. To my mind, a great mistake is made in this country in not putting on enough water when the binding has been laid, and the result is that the binding material, instead of sinking into the interstices of the metal, simply clings to the roller, pulling up bits of the metal, and thus disturbing the whole roadway. As so much water is required for metalling roads, it follows that this work should be only carried out during the rainy season, the metal being collected during the dry seasons of the year; from what I have seen, however, of municipalities in Bengal, this very important point does not receive sufficient attention, and it is a very common thing to see metalling being laid and consolidated at the end of the rains and the beginning of the cold weather, when the rainfall is diminishing or has practically ceased; difficulties then arise in procuring sufficient water, and if the metal is consolidated with little or no water. The result of this delay in beginning the making or repairs to a road is that the road breaks up and requires repairs so much sooner than if it had been done in the proper season. Before deciding whether a road is to have a new coat of metal or is only to be patch-repaired, it should be cut open down to the soling at intervals and the existing depth of metal actually measured. If the depth of metalling is found to be less than 3 to 4½ inches, a fresh coating is required, but the practice of piling up coats of metal as soon as the surface begins to show signs of wear is objectionable, because it gradually raises the surface of the road above the level of the court-yards of the houses, and thus interferes with the surface-drainage. Before new metal is laid on the top of old, the latter must invariably be broken up with a pickaxe to a depth of at least 1½ inch, otherwise the new metal will not consolidate with the old.

And now, gentlemen, I have come to the end of the subjects on which I said, in my first lecture, I should address you, and I trust that what I have said to you has justified me in placing them in the order of importance that I did, namely, first and above all water-supply, second drainage, third conservancy, and lastly roads. I feel satisfied that the subject of municipal engineering is one that has interested you, because you have listened to what I have had to say with so much patience and attention, and my only hope is that you will not allow the present to be the last thought that you will give to the subject; for even should none of you enter the service of Municipal Commissioners, you will, as I explained in my first lecture, be able to make use of some of the information that I have placed before you in other walks of life. Whatever may be your future career, you can preserve your own health by due attention to the ordinary laws of hygiene and sanitation; but above all you can help others to the greater enjoyment of life. To those of you who become municipal engineers, I would say—never use the word *kal* (to-morrow); for whatever sanitary work has to be done must be done at once; no evil arising from the want of attention to sanitary laws, which are, after all, Nature's laws, must be allowed to continue for one second longer than can be helped. And further do not attempt to please everybody, for it is an impossibility; where the sanitation of a municipality is concerned, there are so many conflicting interests: do your best to attend to the rules of



sanitation honestly and straightforwardly, and never allow any one man's interests or personal comfort to interfere with the health and well-being of the community. To one and all of you I would say—assist and help Nature all you can, and never resist Her unalterable laws: resistance means sickness and an early death, while assistance will bring its reward in a healthy and long life.

---

### BIBLIOGRAPHY.

1. A Treatise on Hydraulic and Water-supply Engineering. J. T. Fanning.
2. The Principles of Waterworks Engineering. J. H. Tudsbury and A. W. Brightmore.
3. A Manual of Hygiene, Sanitation and Sanitary Engineering. J. A. Jones.
4. Sanitary Engineering. Colonel C. E. S. Moore, R.E.
5. Pumping Machinery. W. M. Barr.
6. Indicator Diagrams and Engine and Boiler Testing. Charles Day.
7. The Theory and Practice of Hygiene. J. L. Notter and R. H. Firth.
8. Rural Hygiene. G. V. Poore.



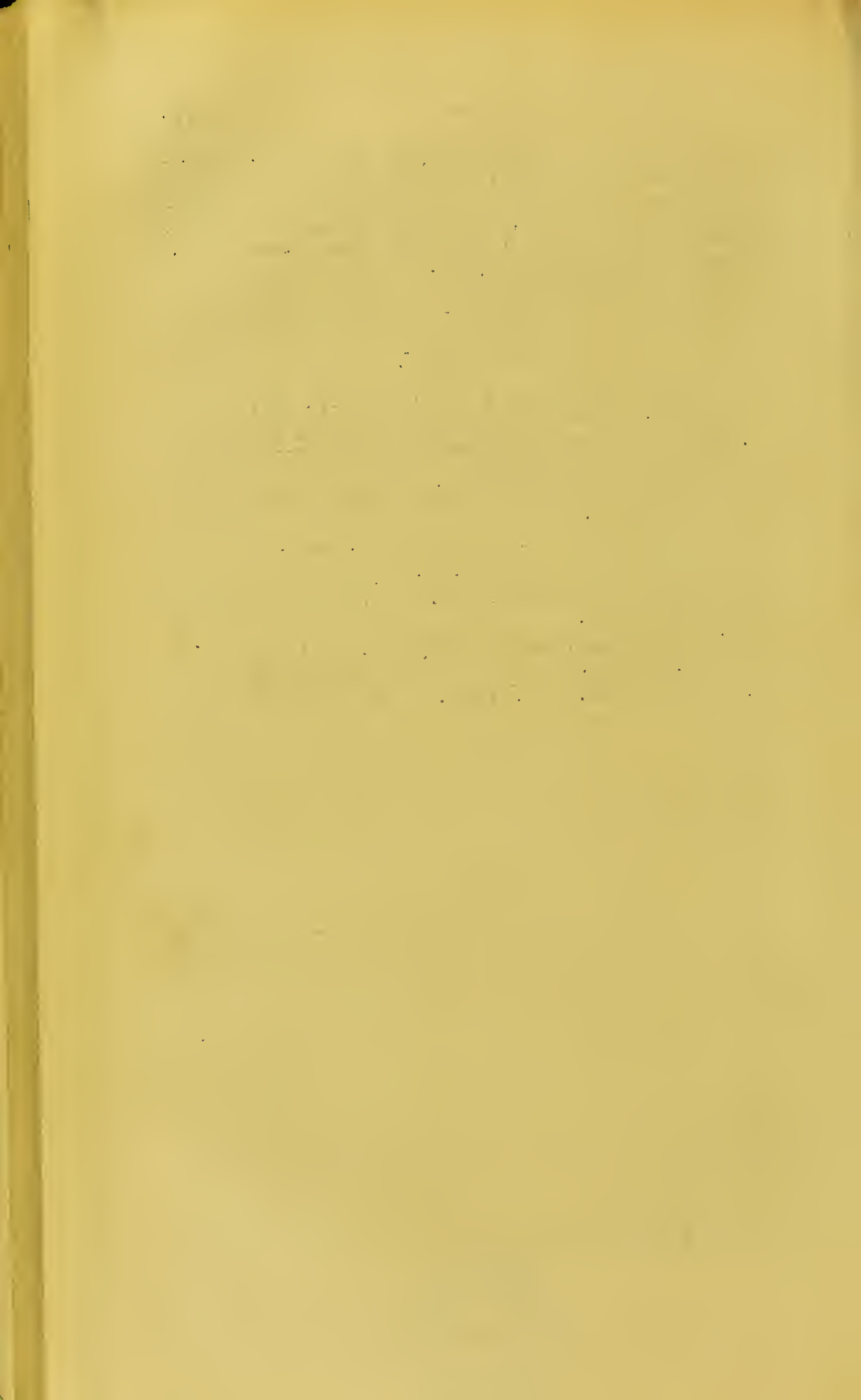

# PATNA WATER SUPPLY SCHEME

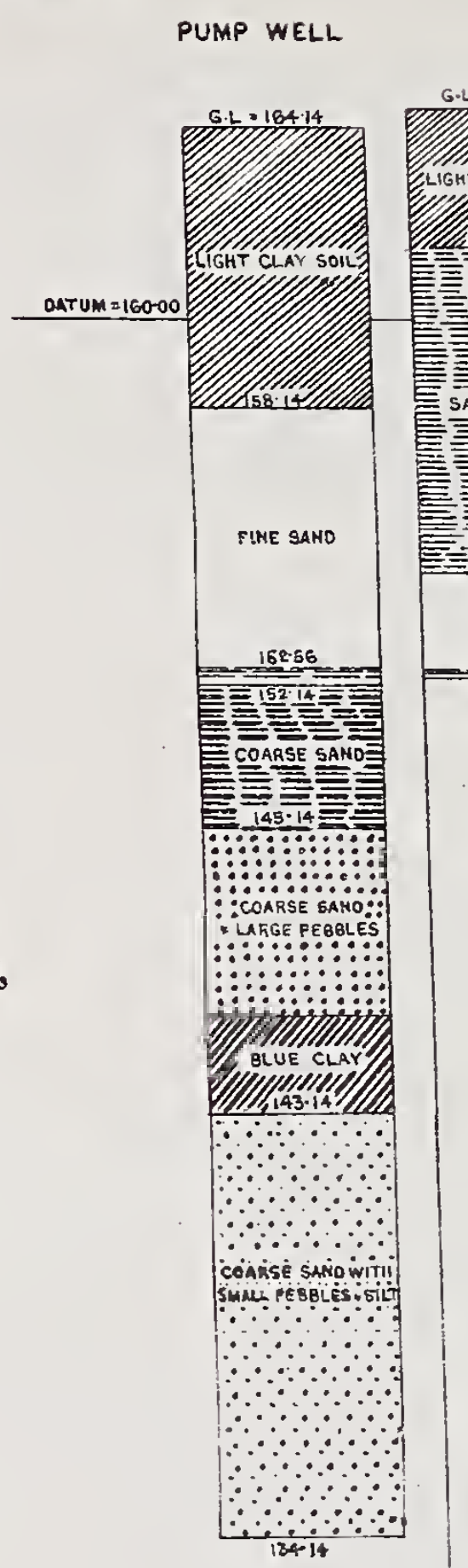
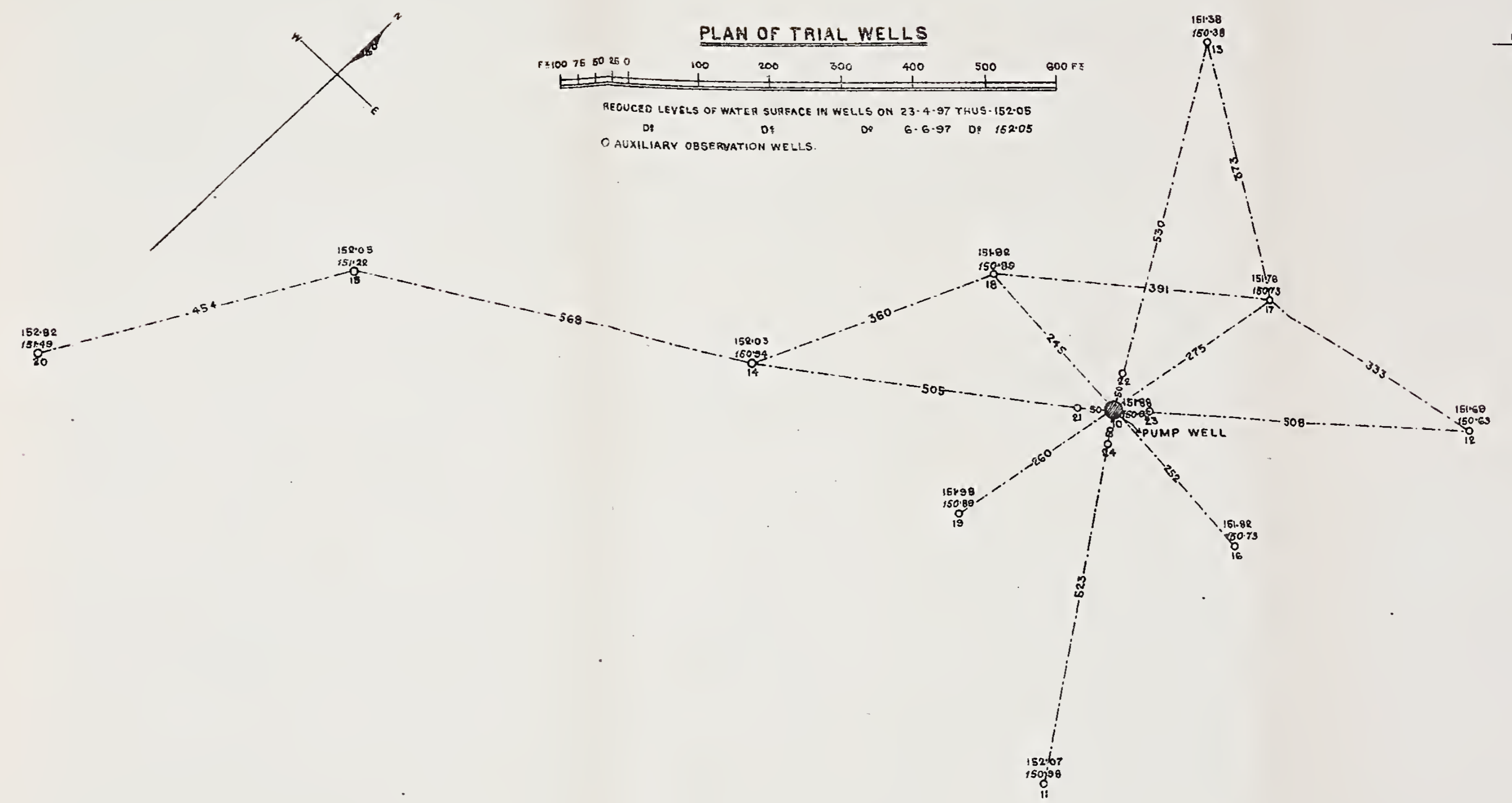

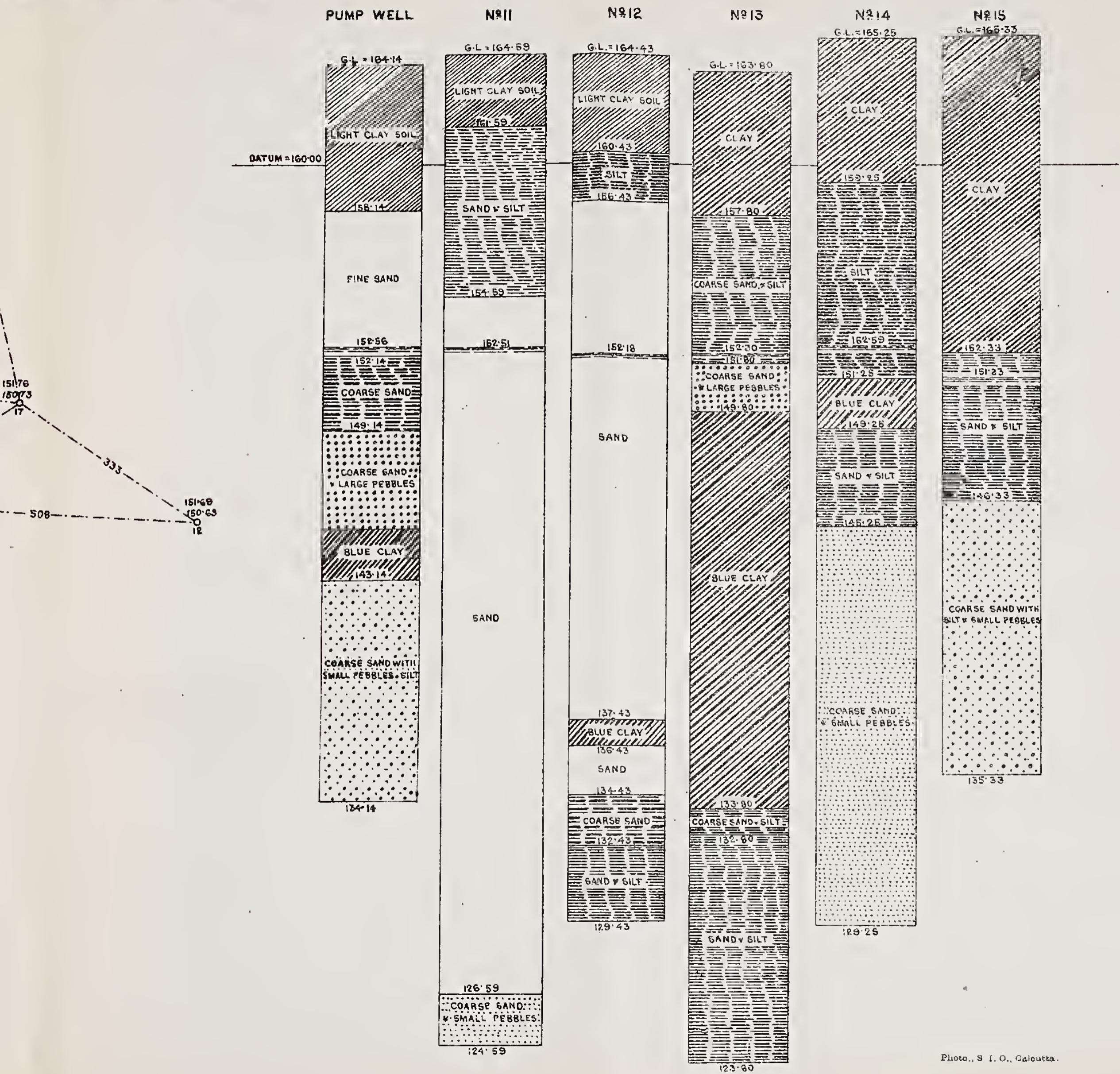

DELHI

PLAN

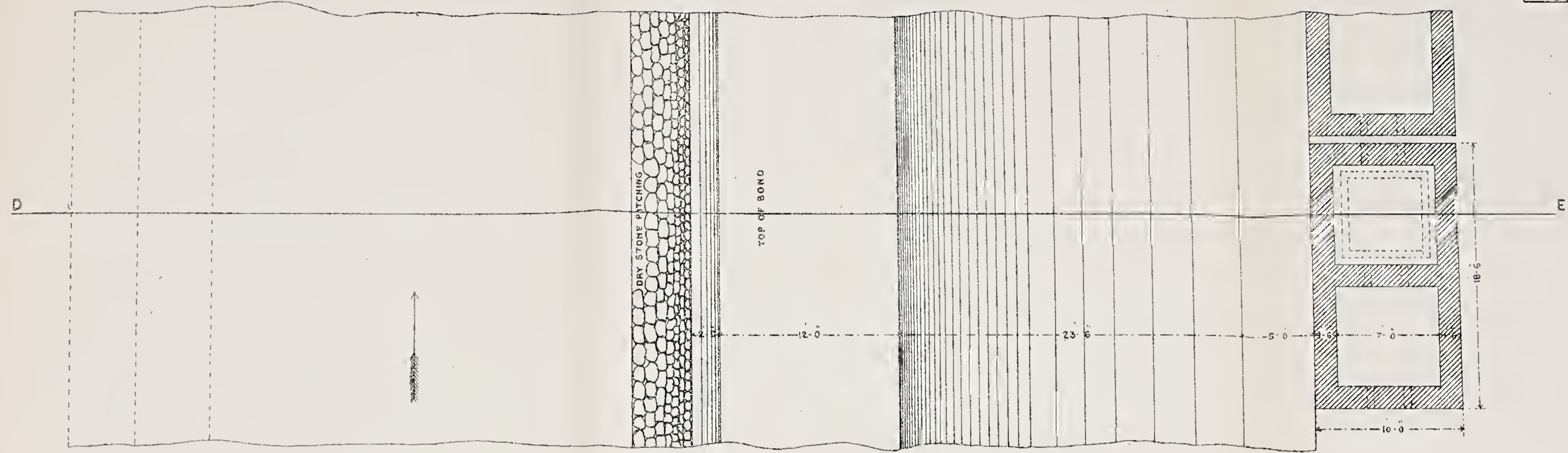

FILTRATION WELLS

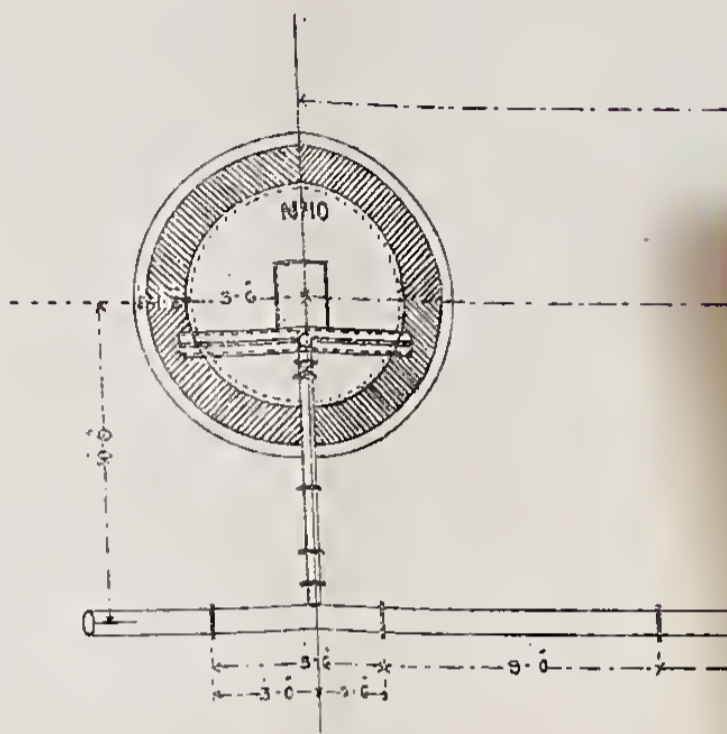

SECTION ON D-E AND PROTECTIVE BUND

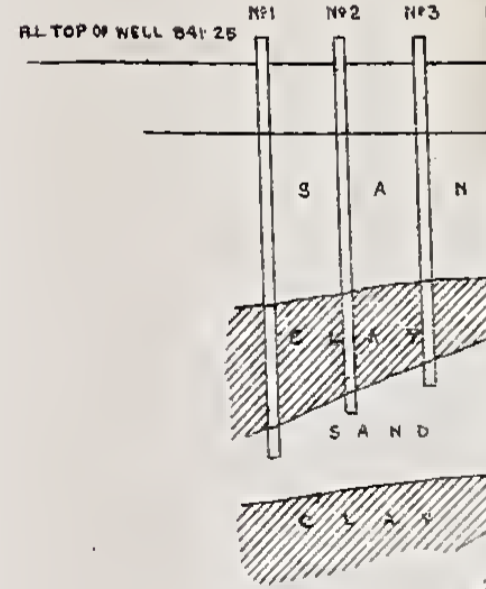
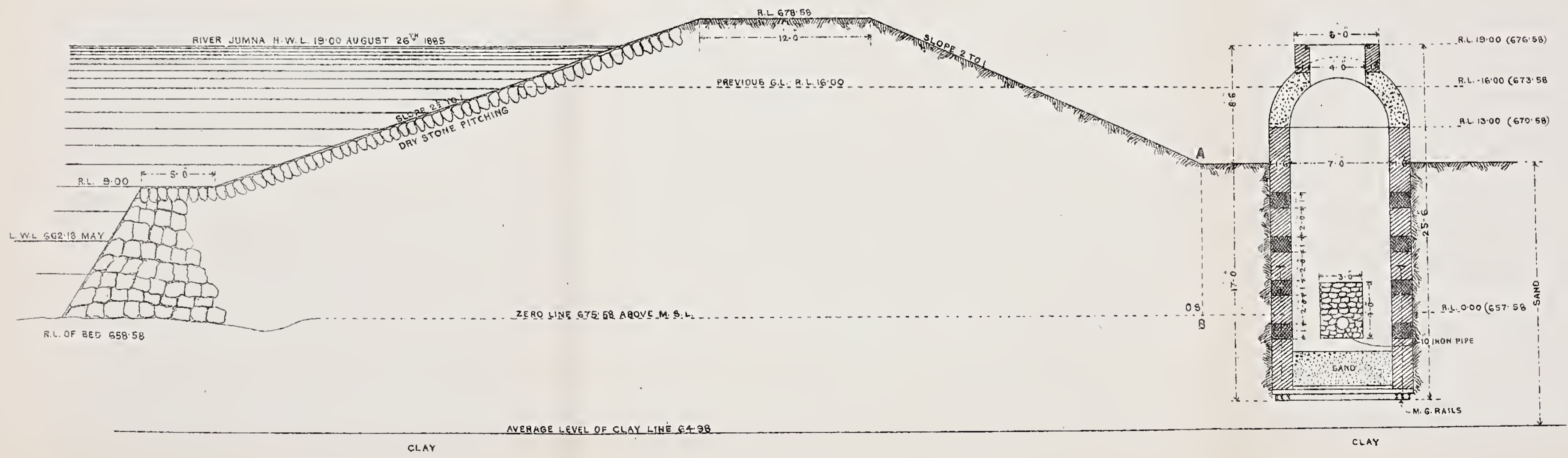

S

# AMBALA

PLAN

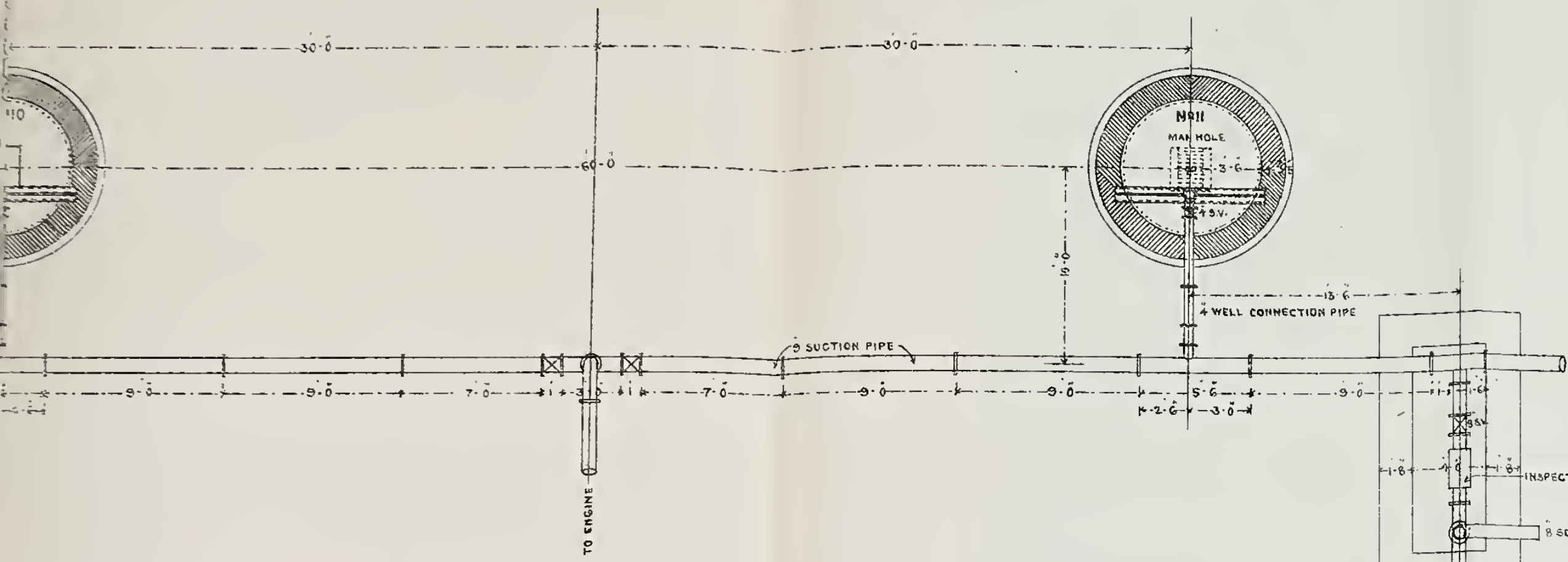

SECTION OF A WELL

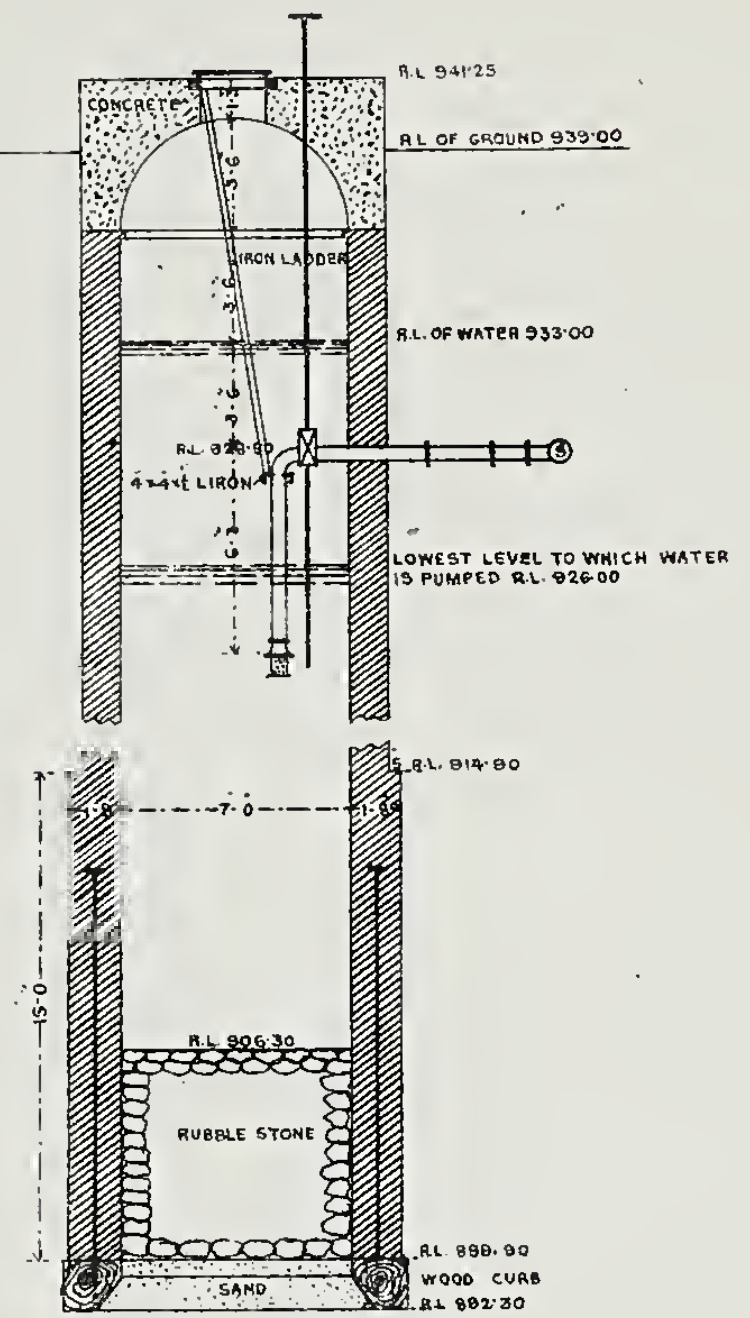

SECTION OF GROUND AT WELLS

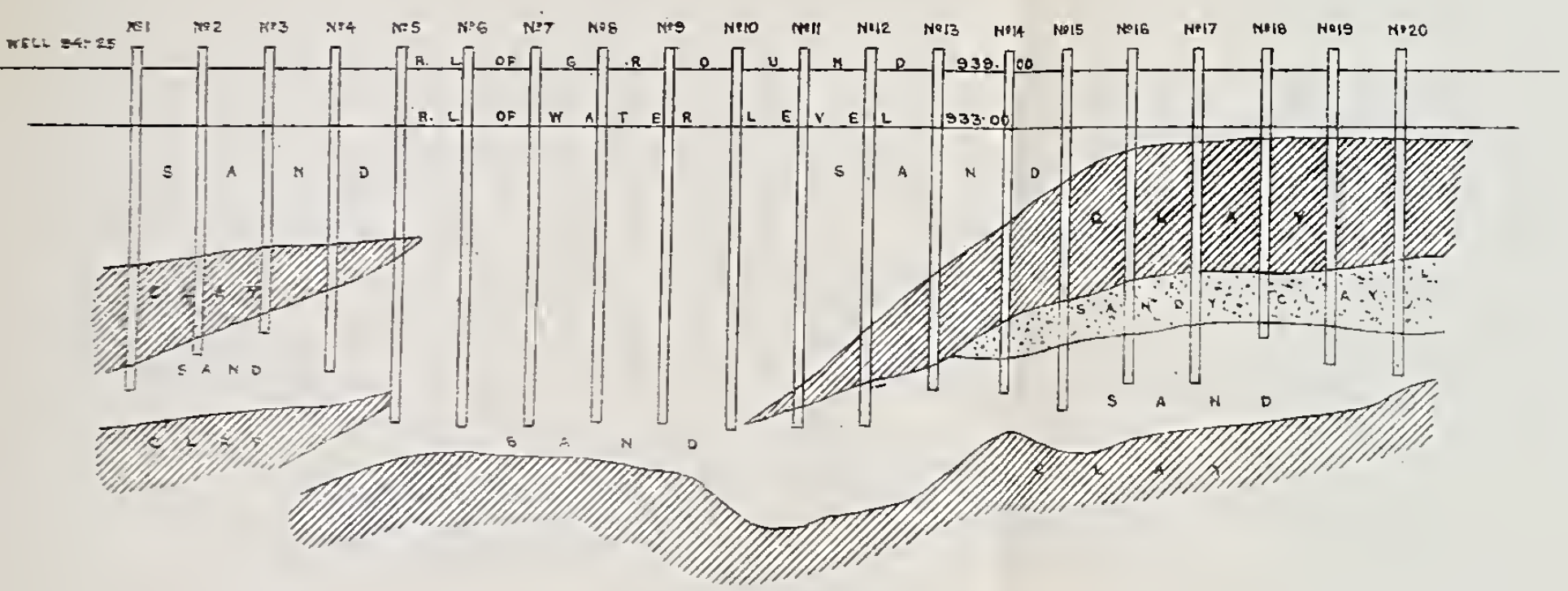
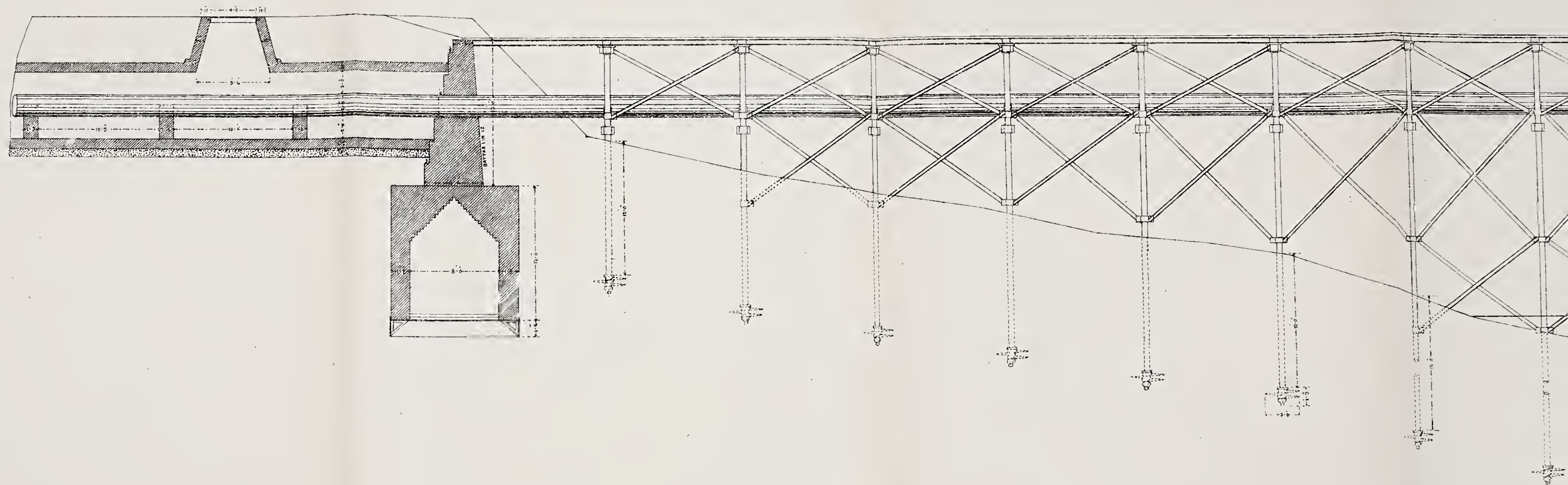
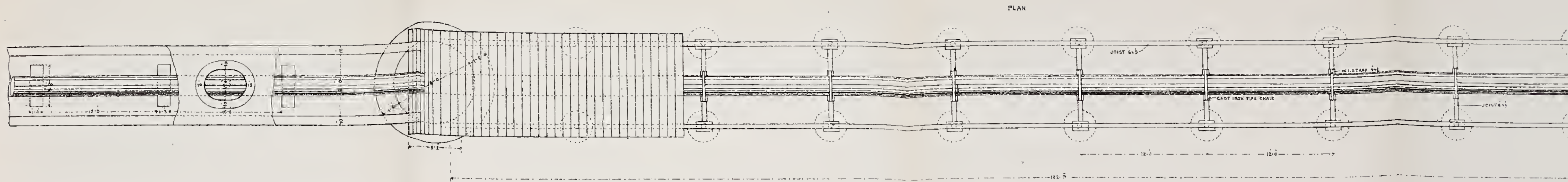
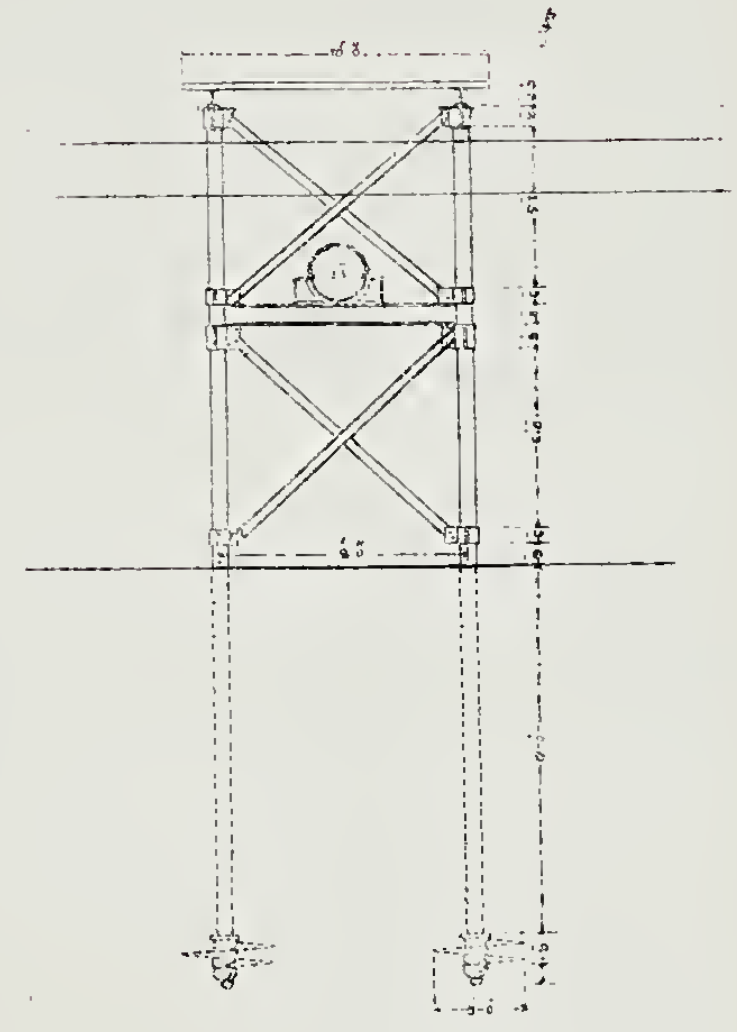
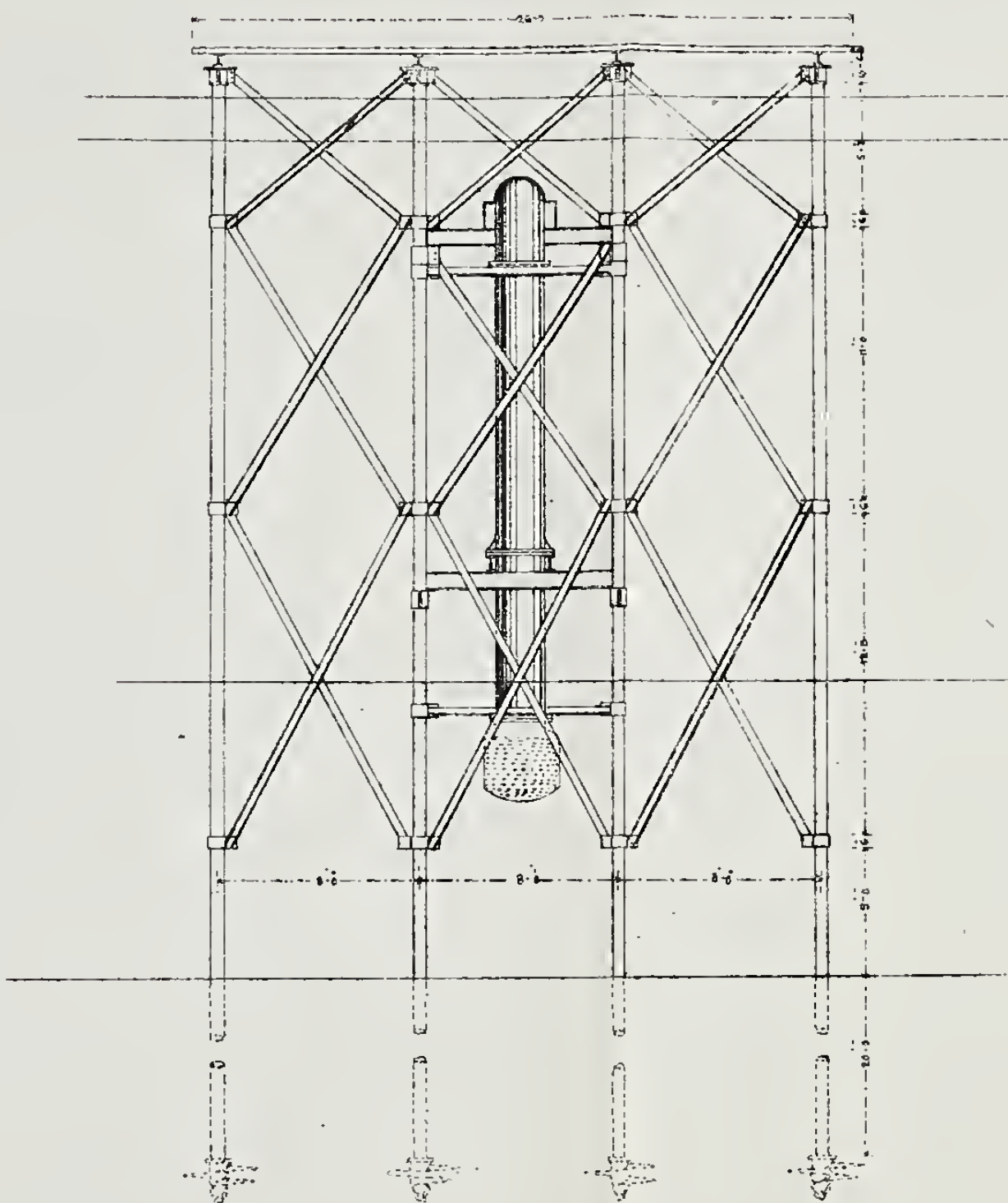
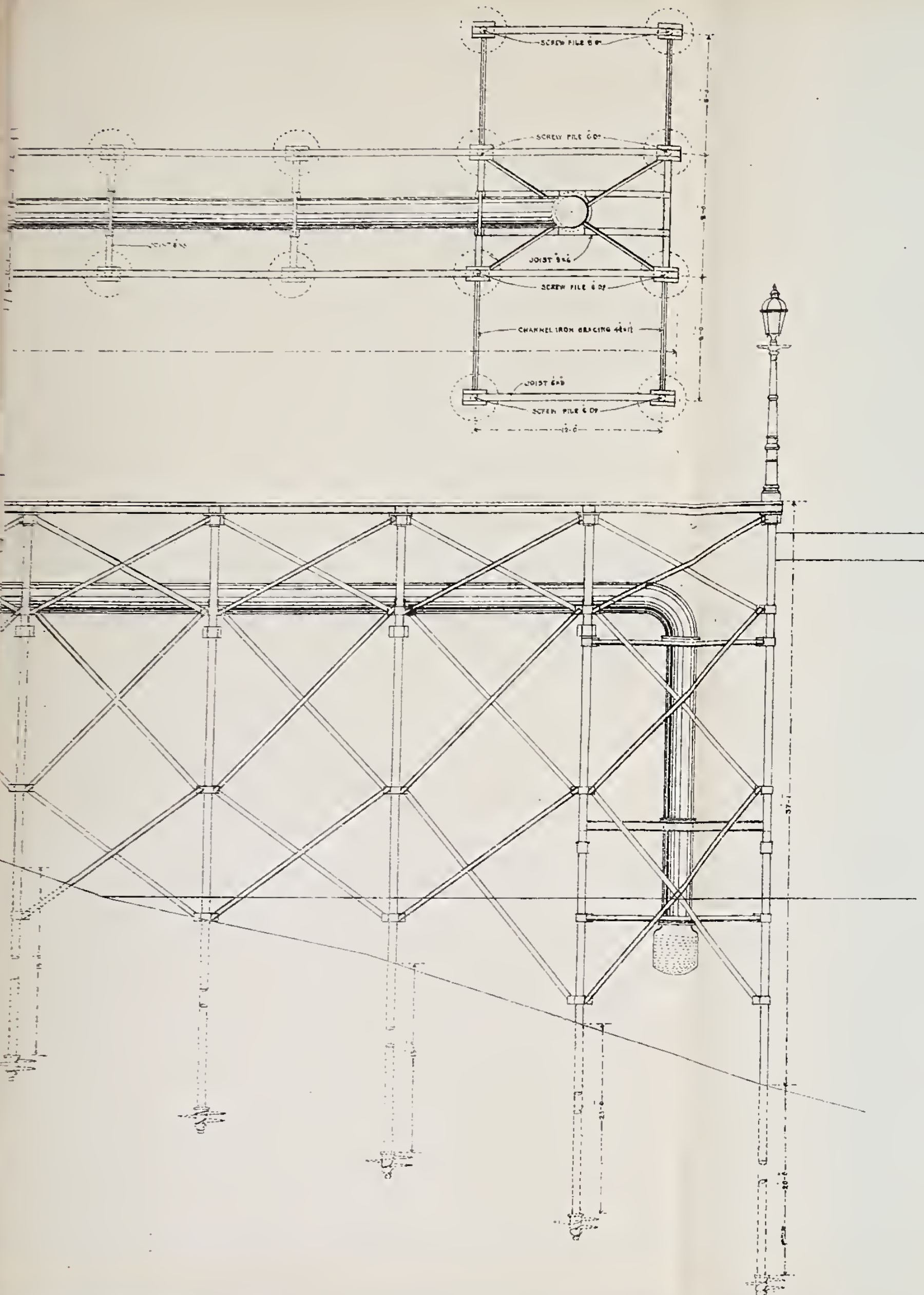

Photo., S. I. O., Calcutta.



# HOWRAH WATER WORKS.

## SUCTION PIPE JETTY





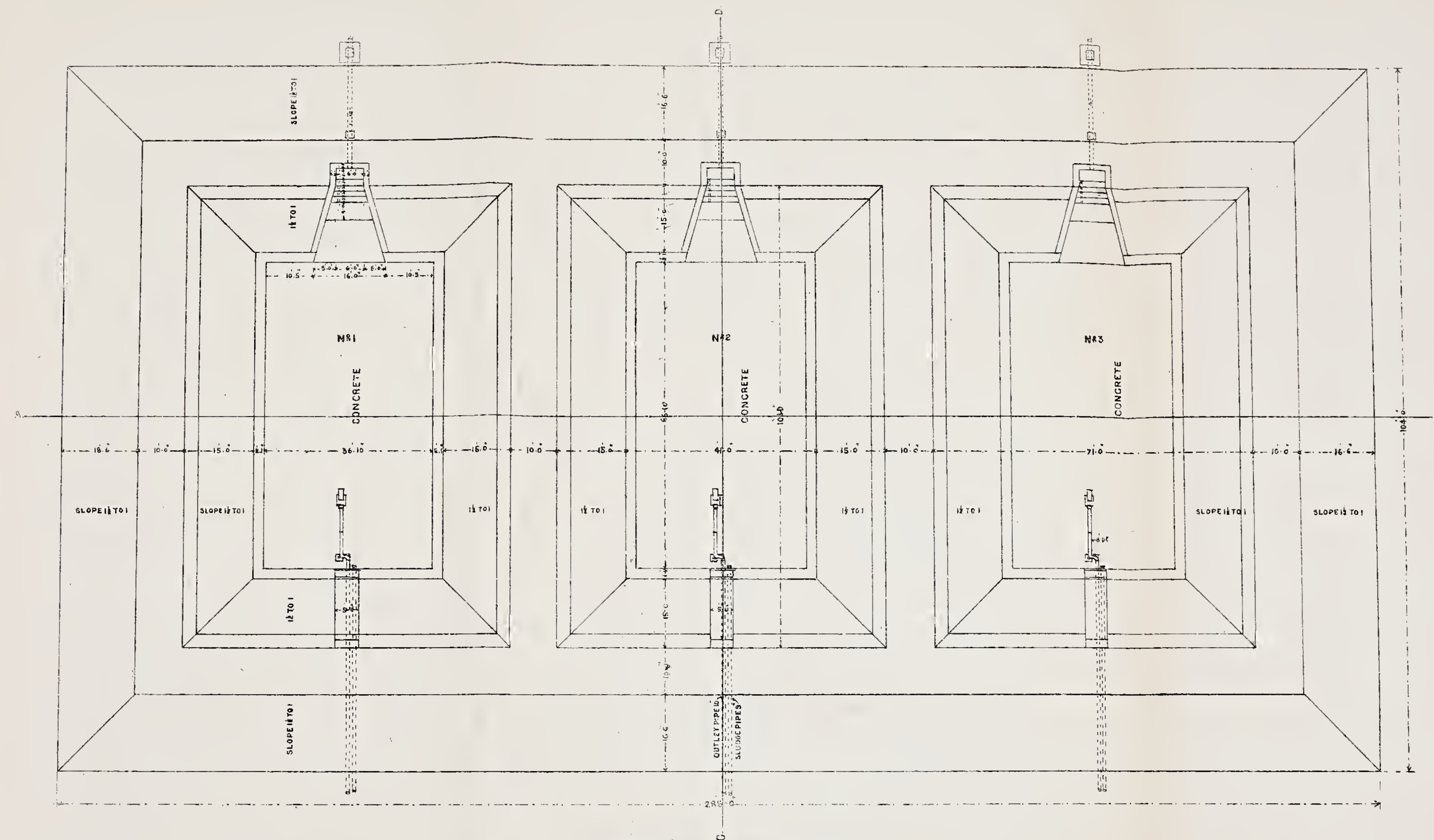
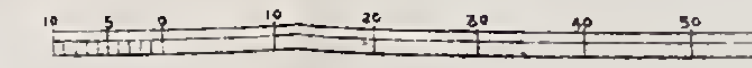

CROSS SECTION ON C.D.

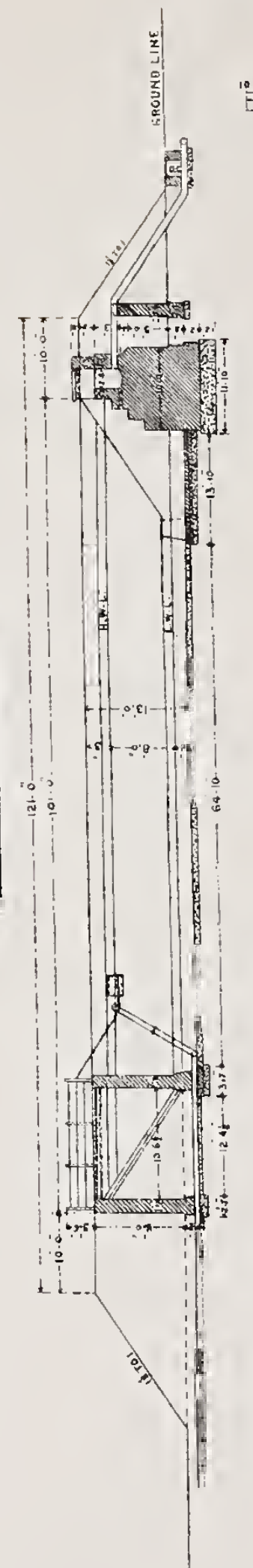

LONGITUDINAL SECTION ON A.B.

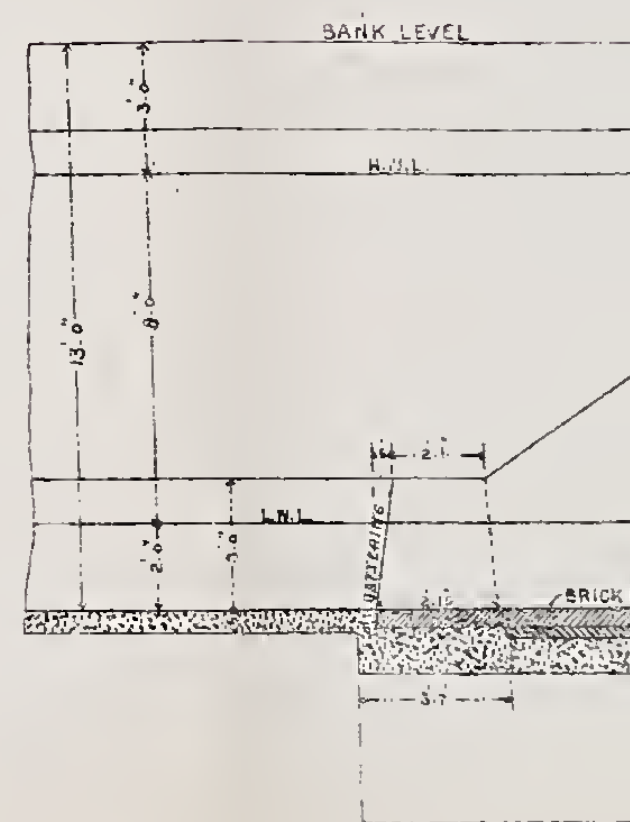
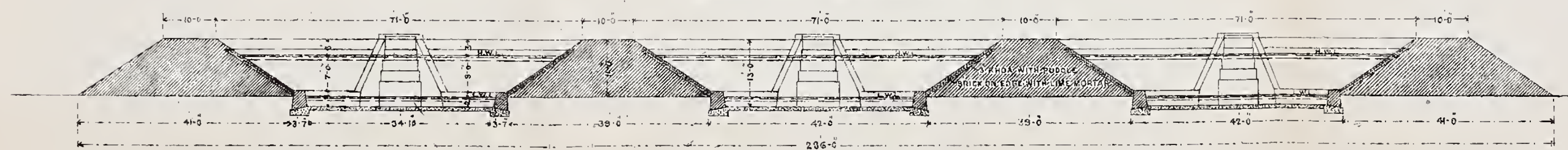

SETTLING TANKS

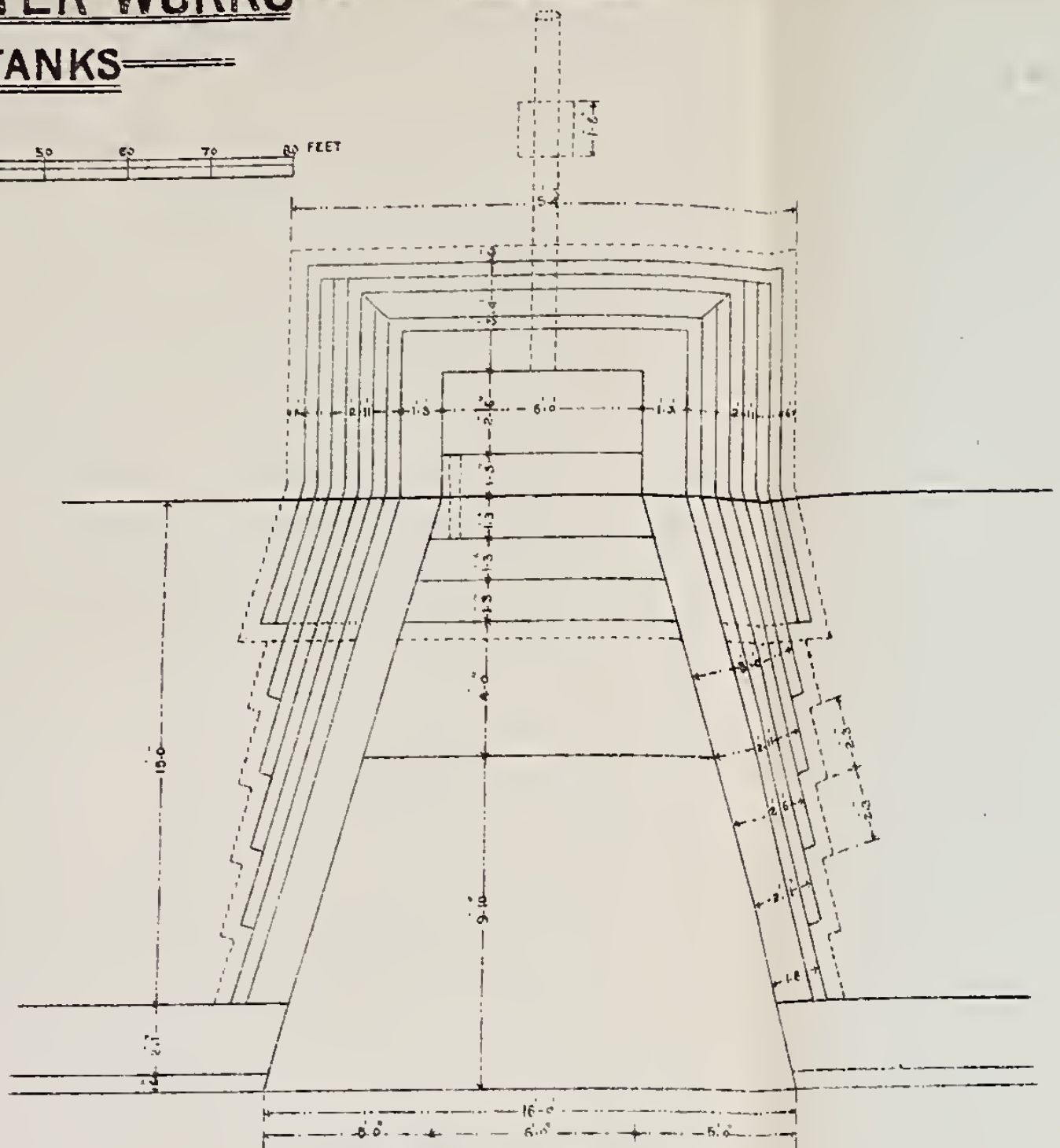
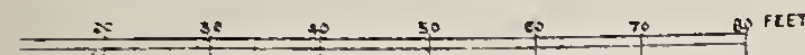

PLAN OF OUTLET JETTY

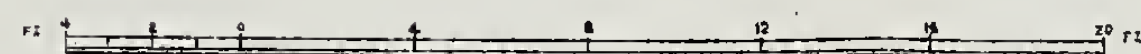
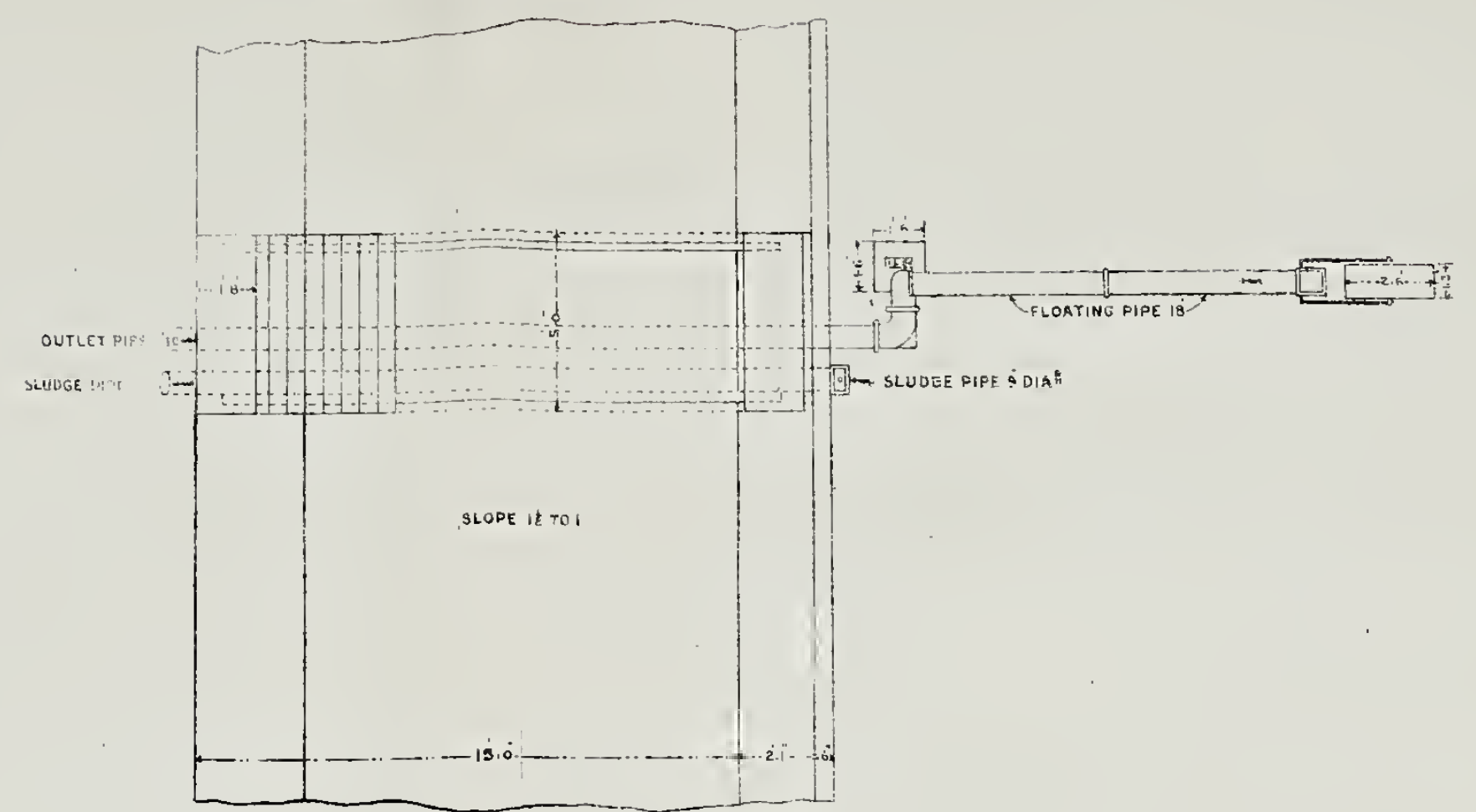

SECTION OF JETTY

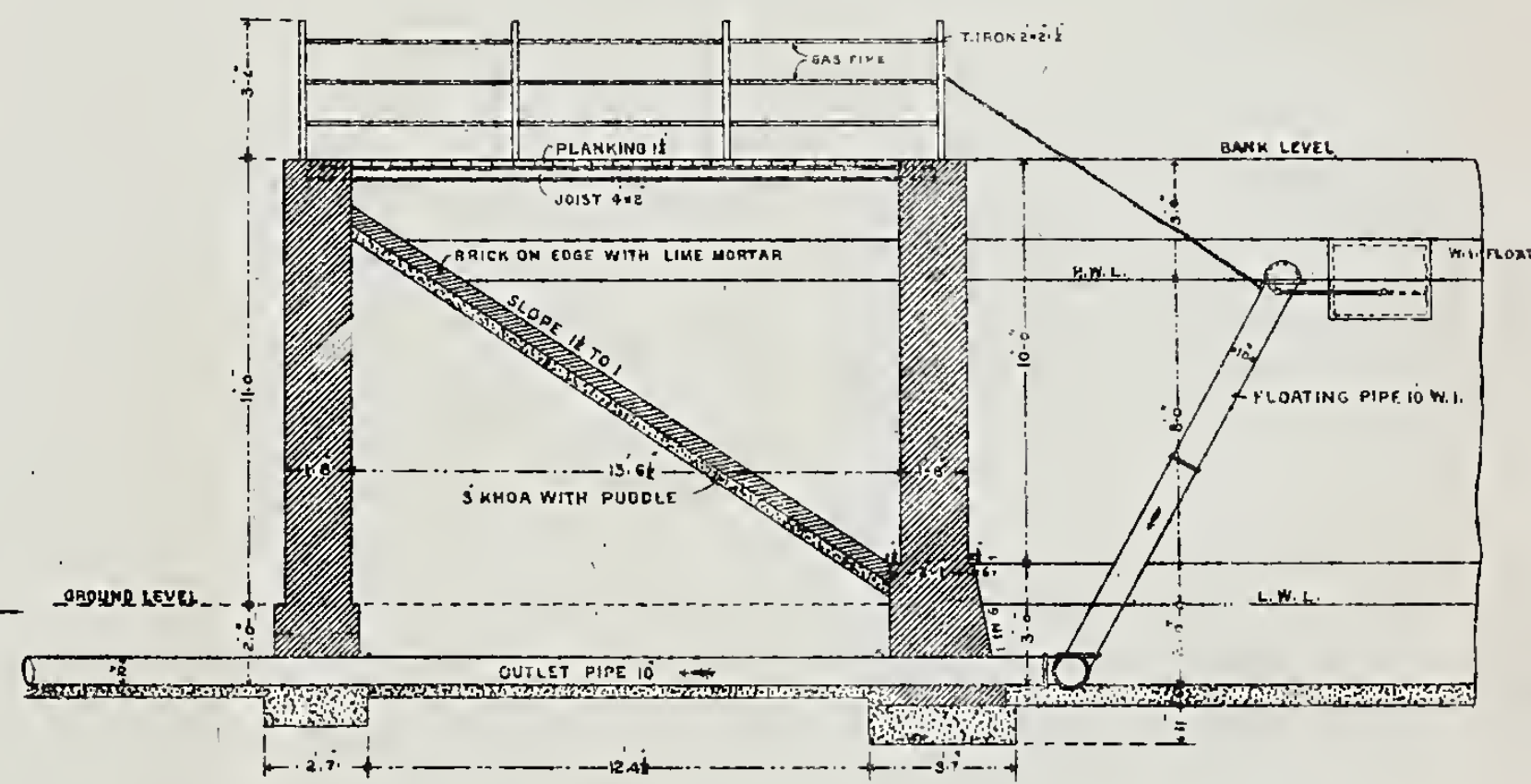

GROSS SECTION OF WEIR

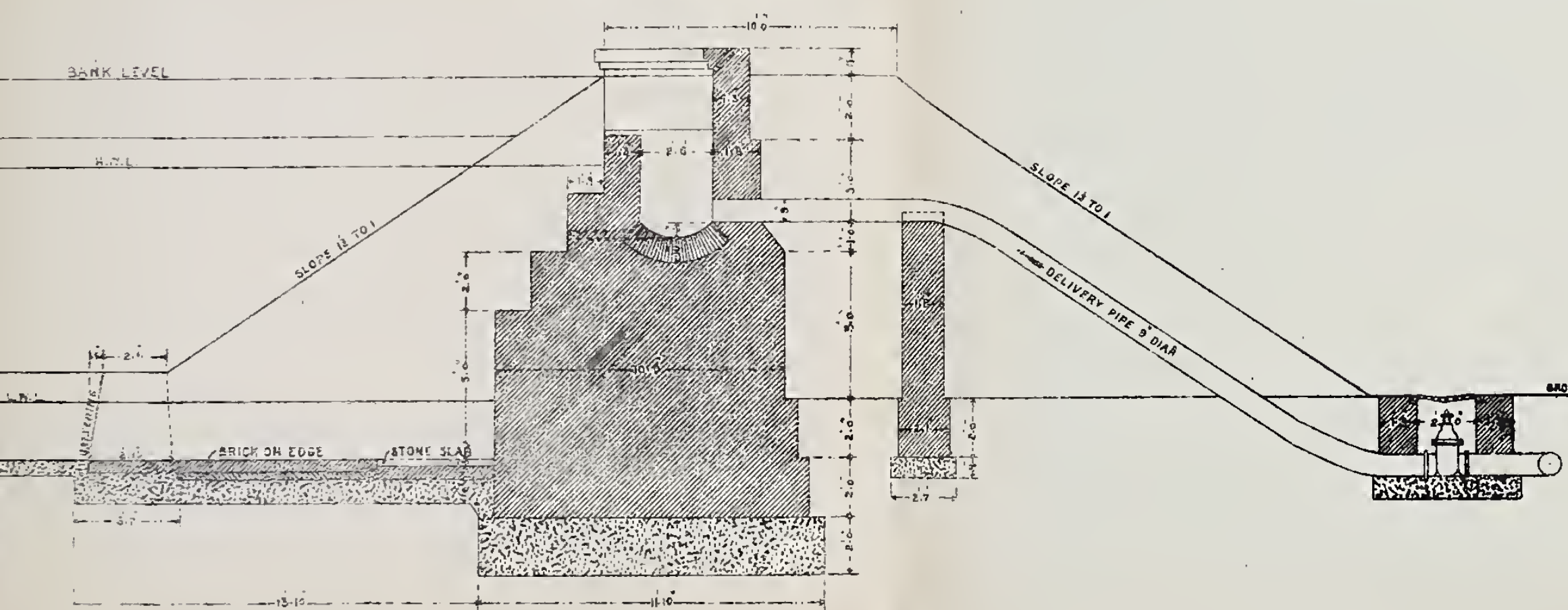

# MEERUT WATER WORKS SETTLING TANKS

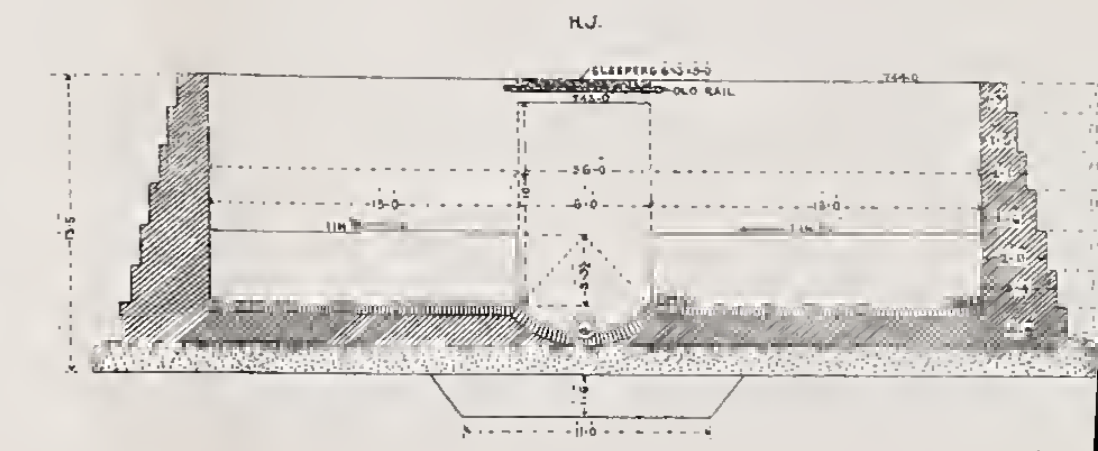
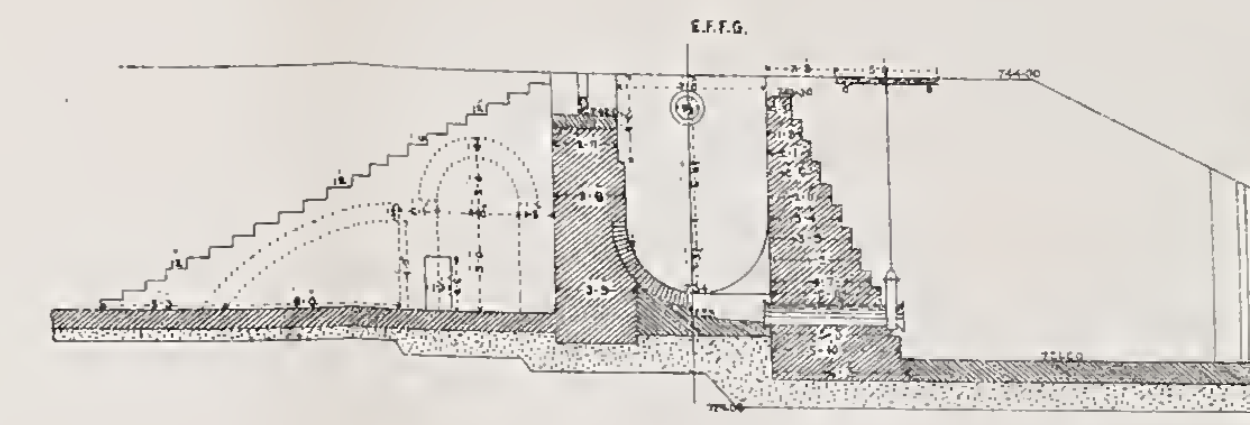
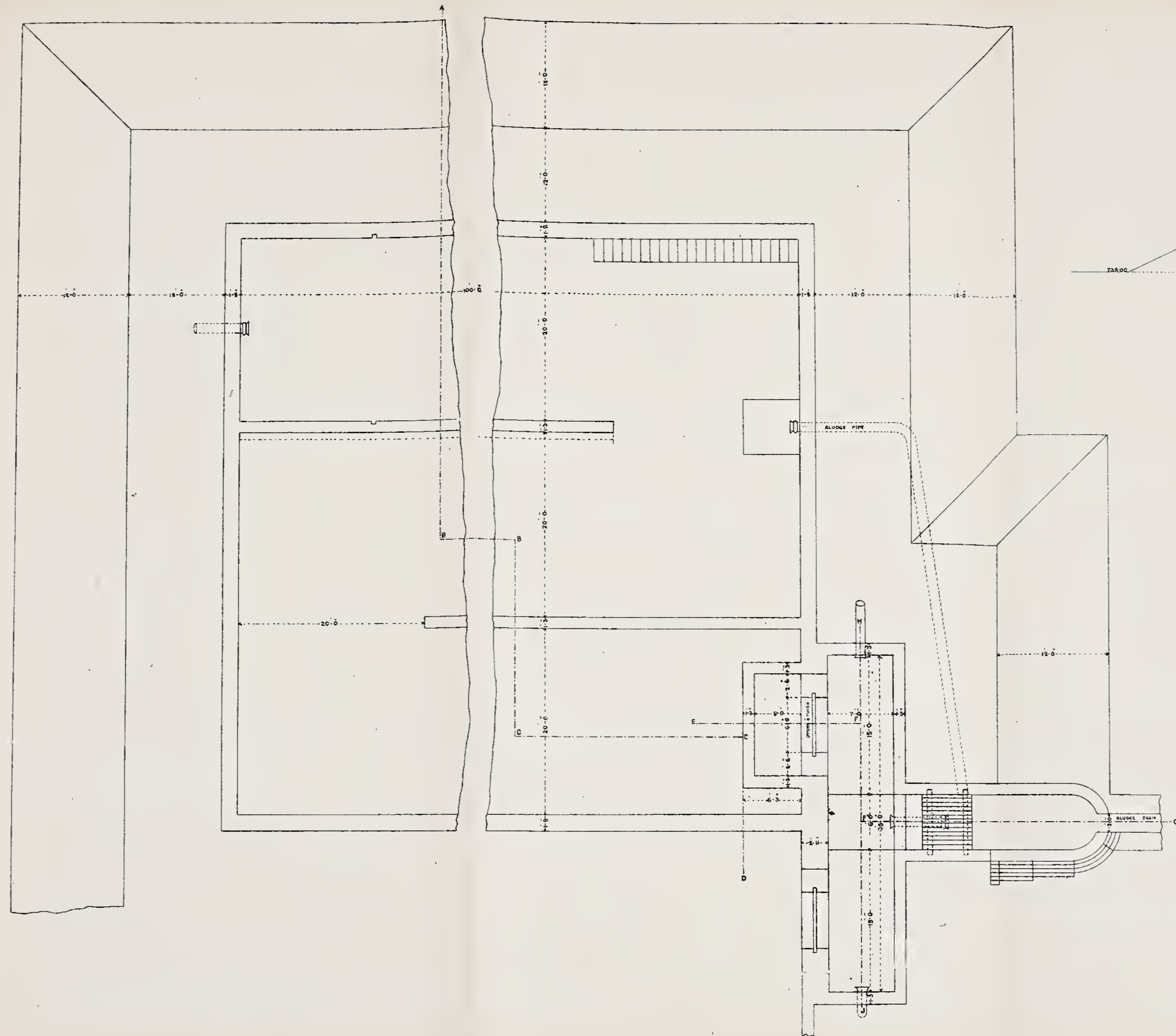

MEERUT WATER WORKS  
SETTLING TANKS

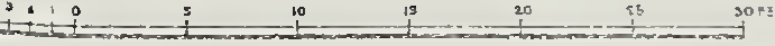

A.B.C.C.D.

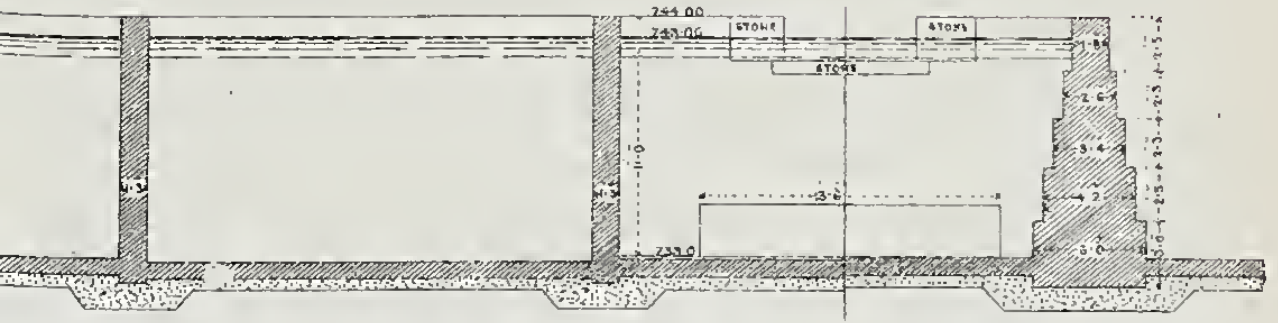

E.F.F.G.

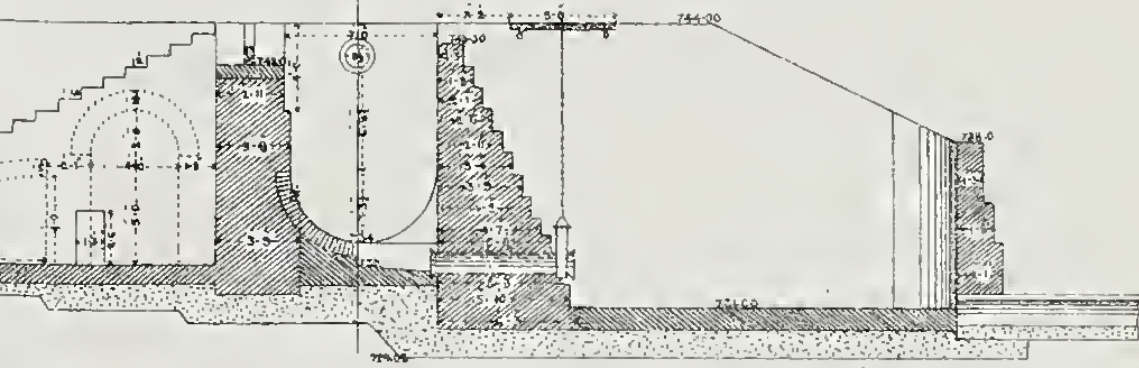

H.J.

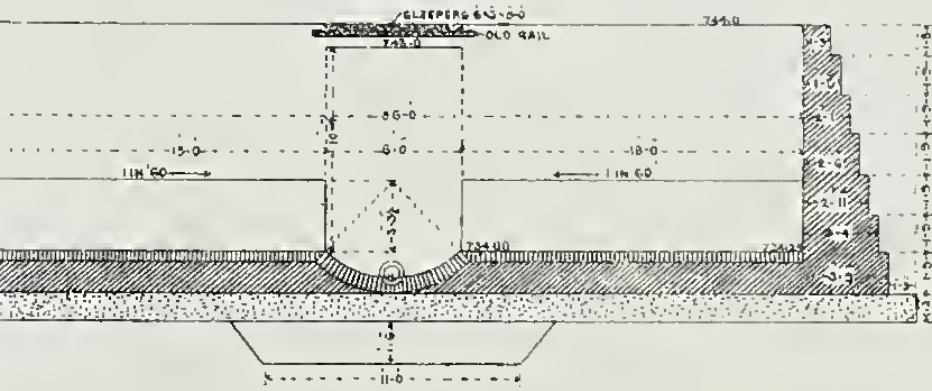

PLAN OF SAND WASHING PIT

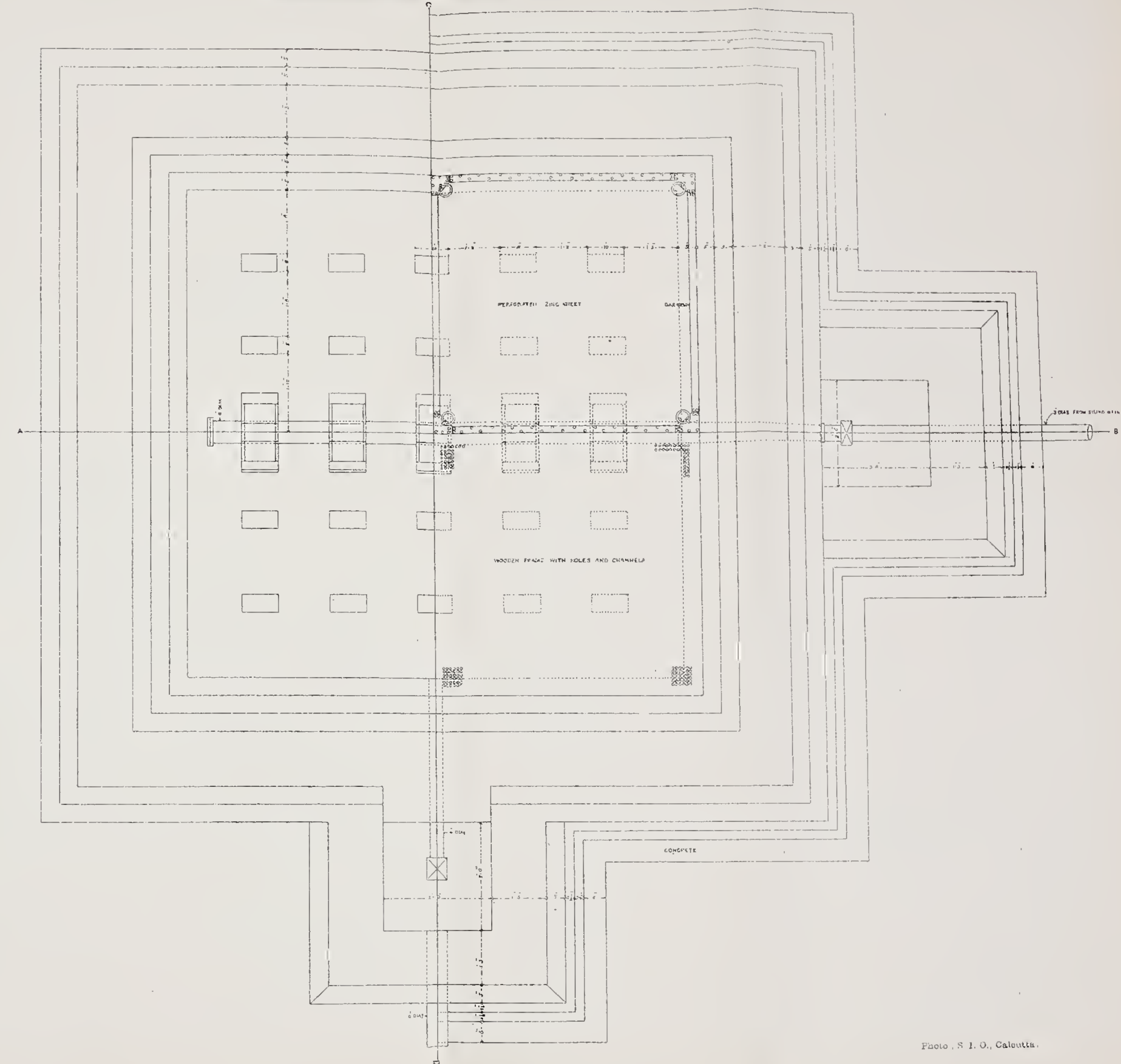
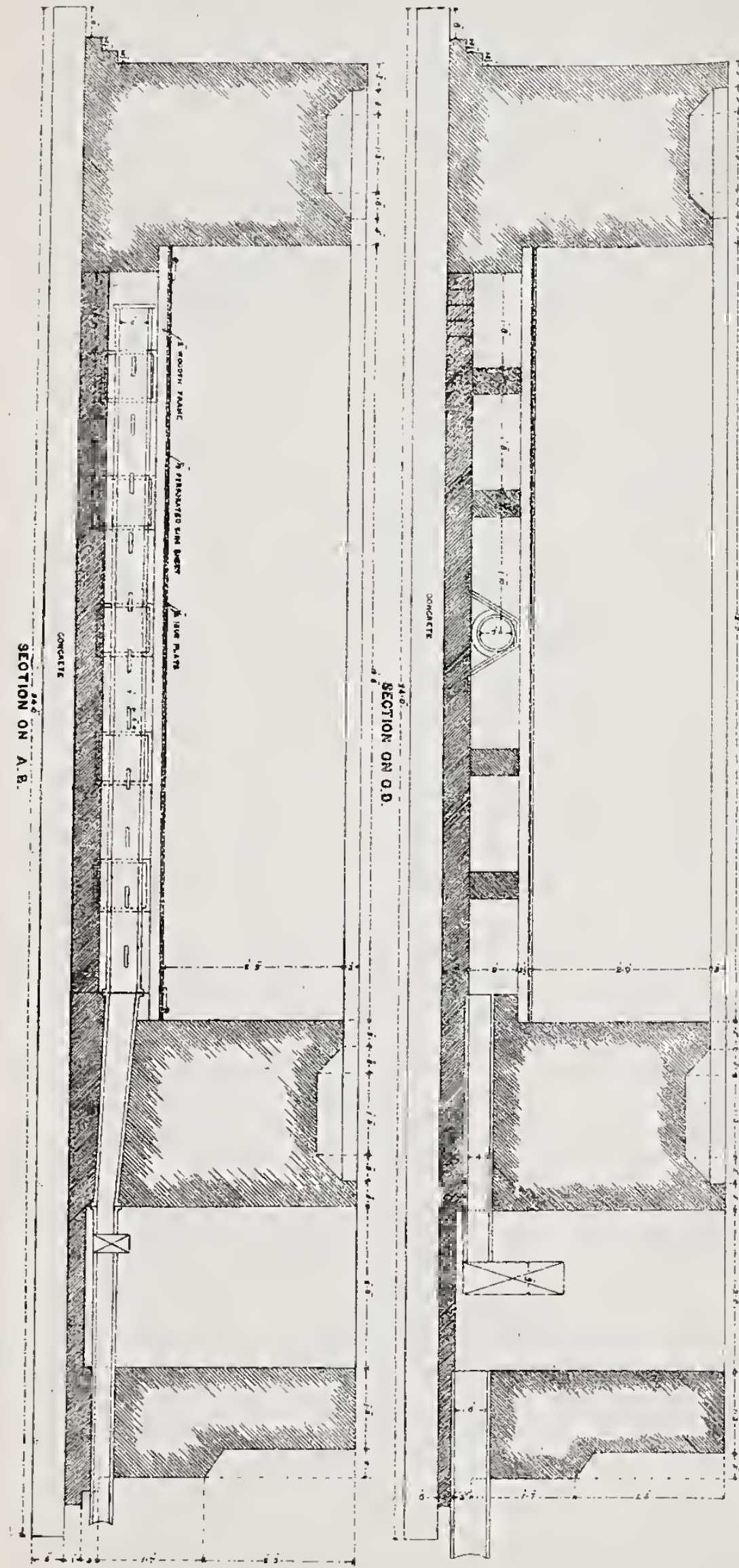



# BERHAMPORE WATER WORKS.

## PLAN OF FILTER BEDS AND CLEAR WATER RESERVOIR

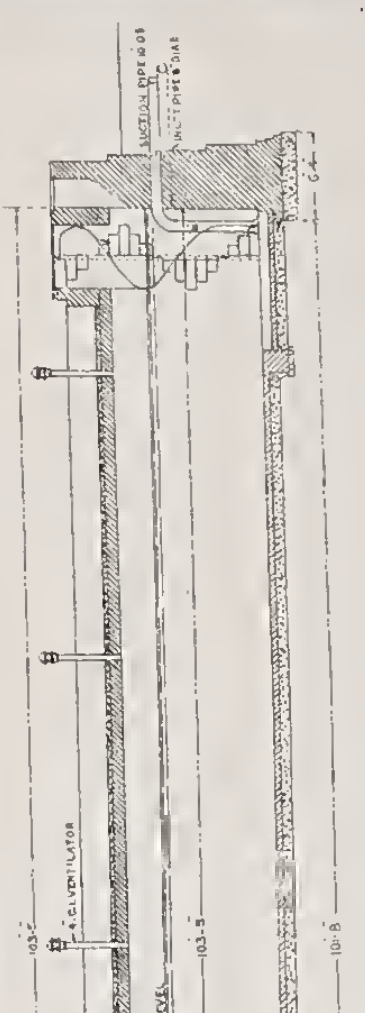
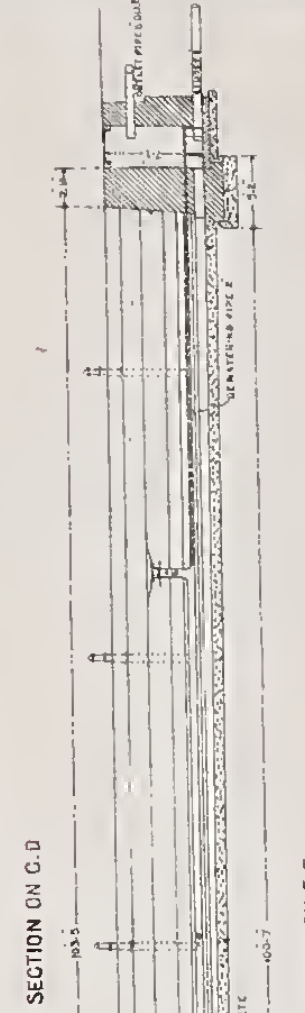
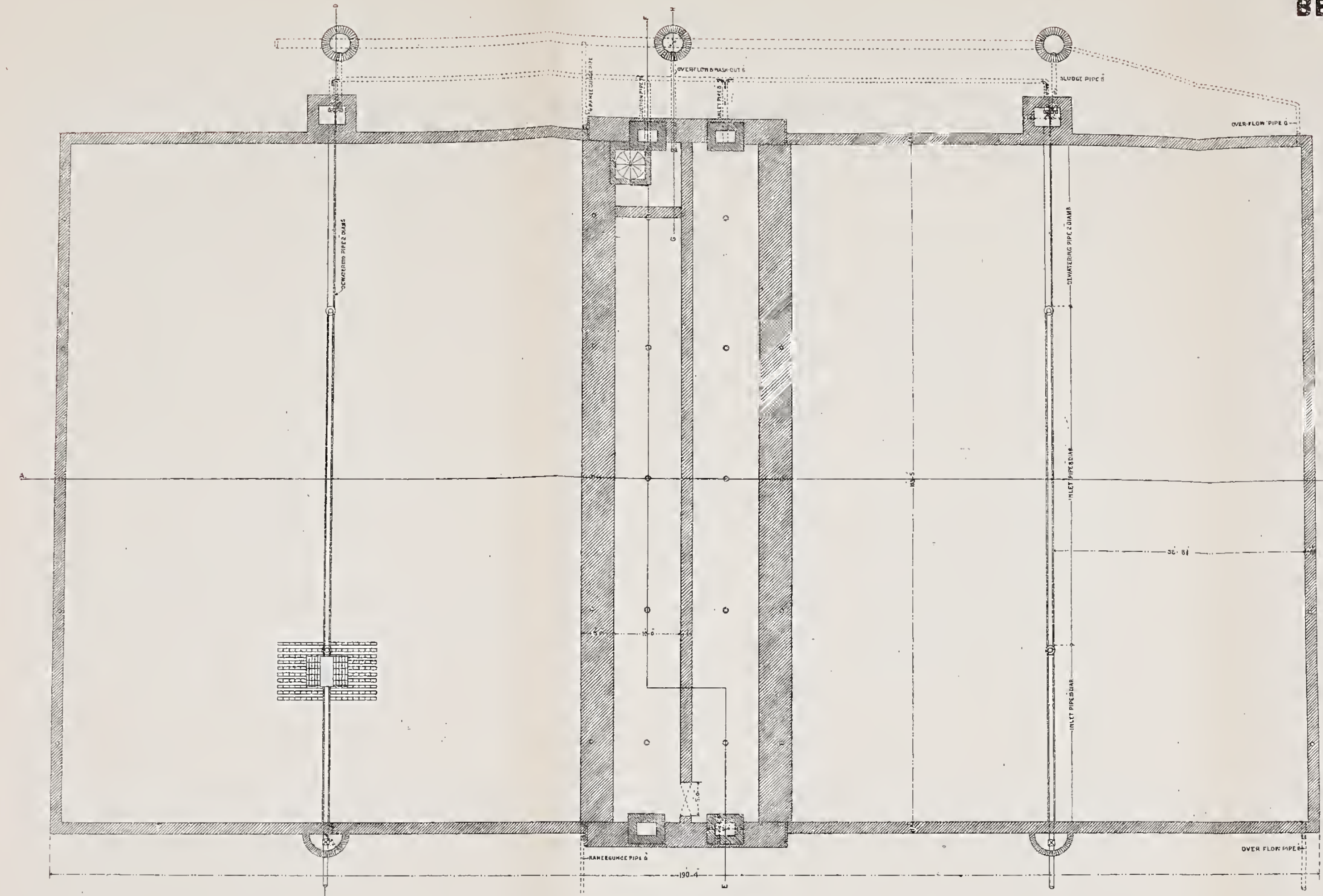

SECTION OF SIDE WALL

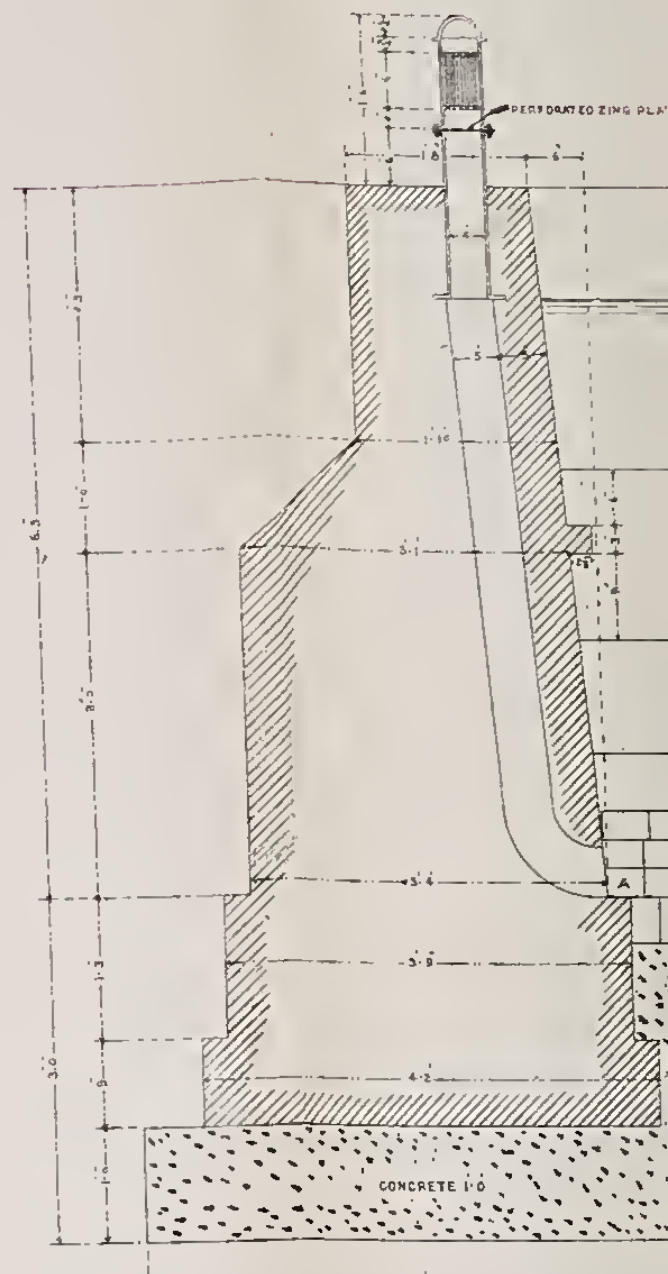

SECTION OF SPREADER

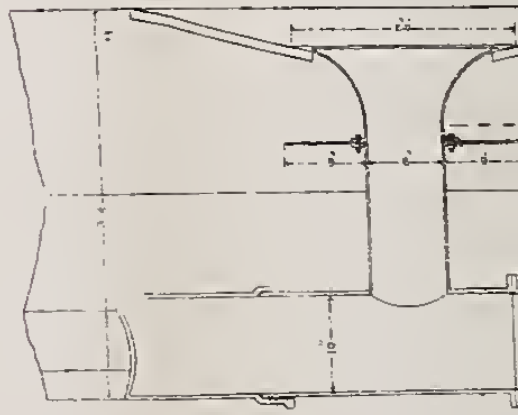

LONGITUDINAL SECTION ON A. B.

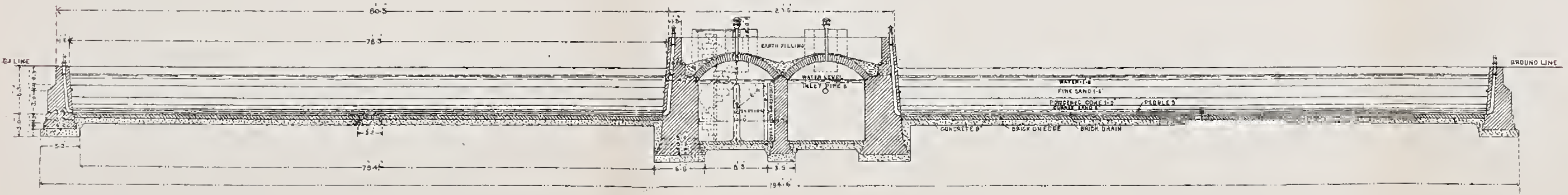

SECTION OF SIDE WALL

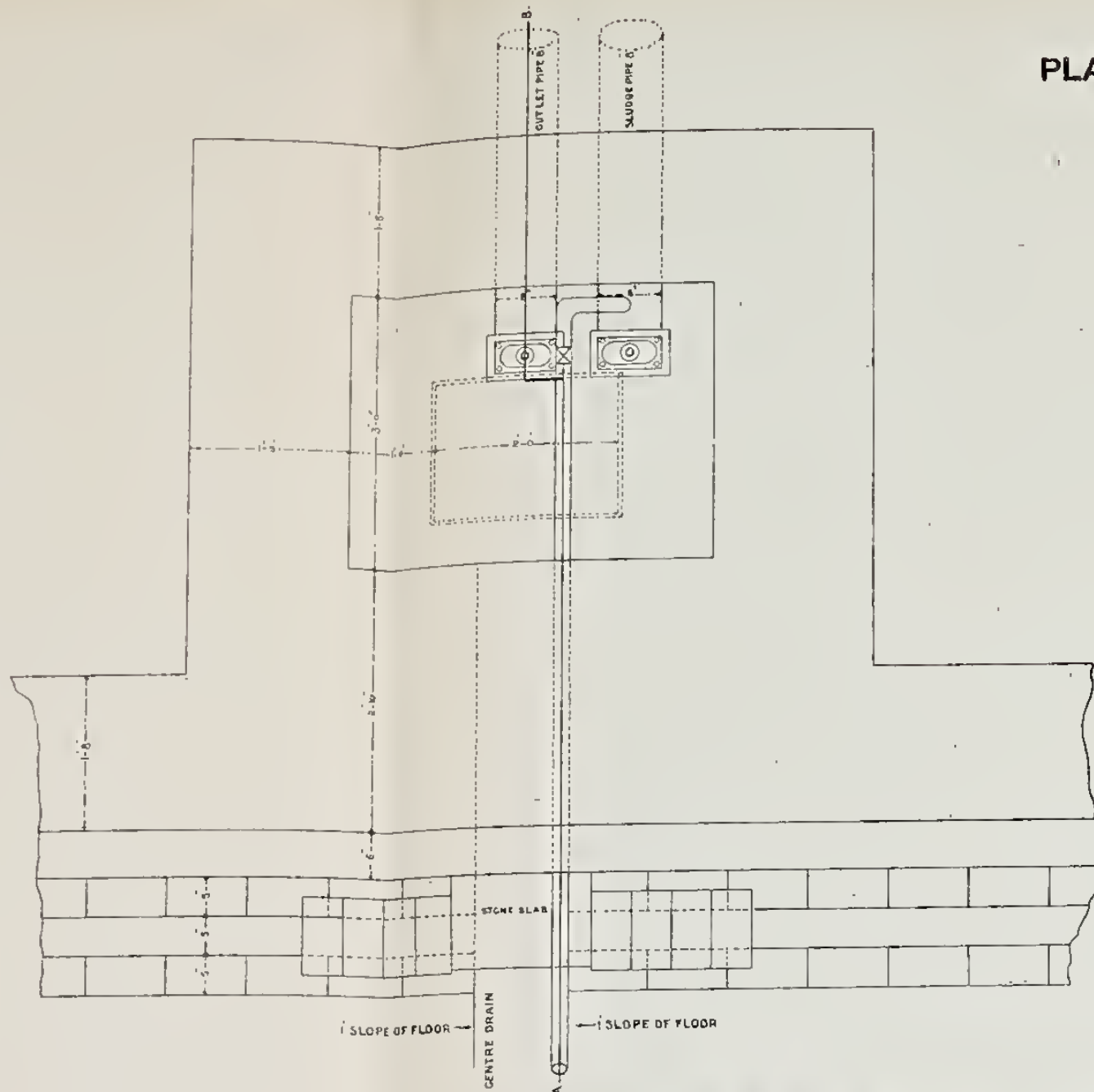
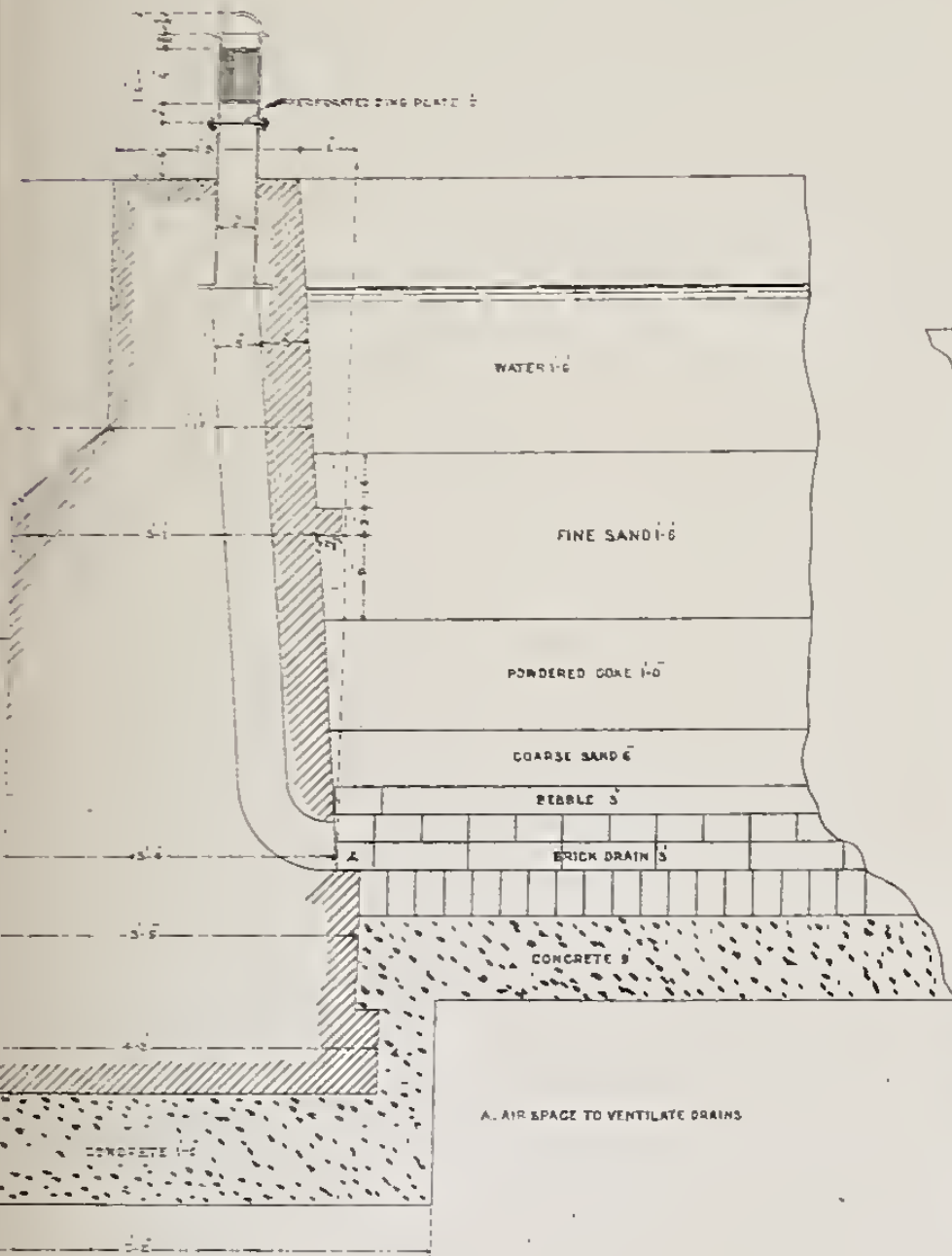

SECTION ON A. B.

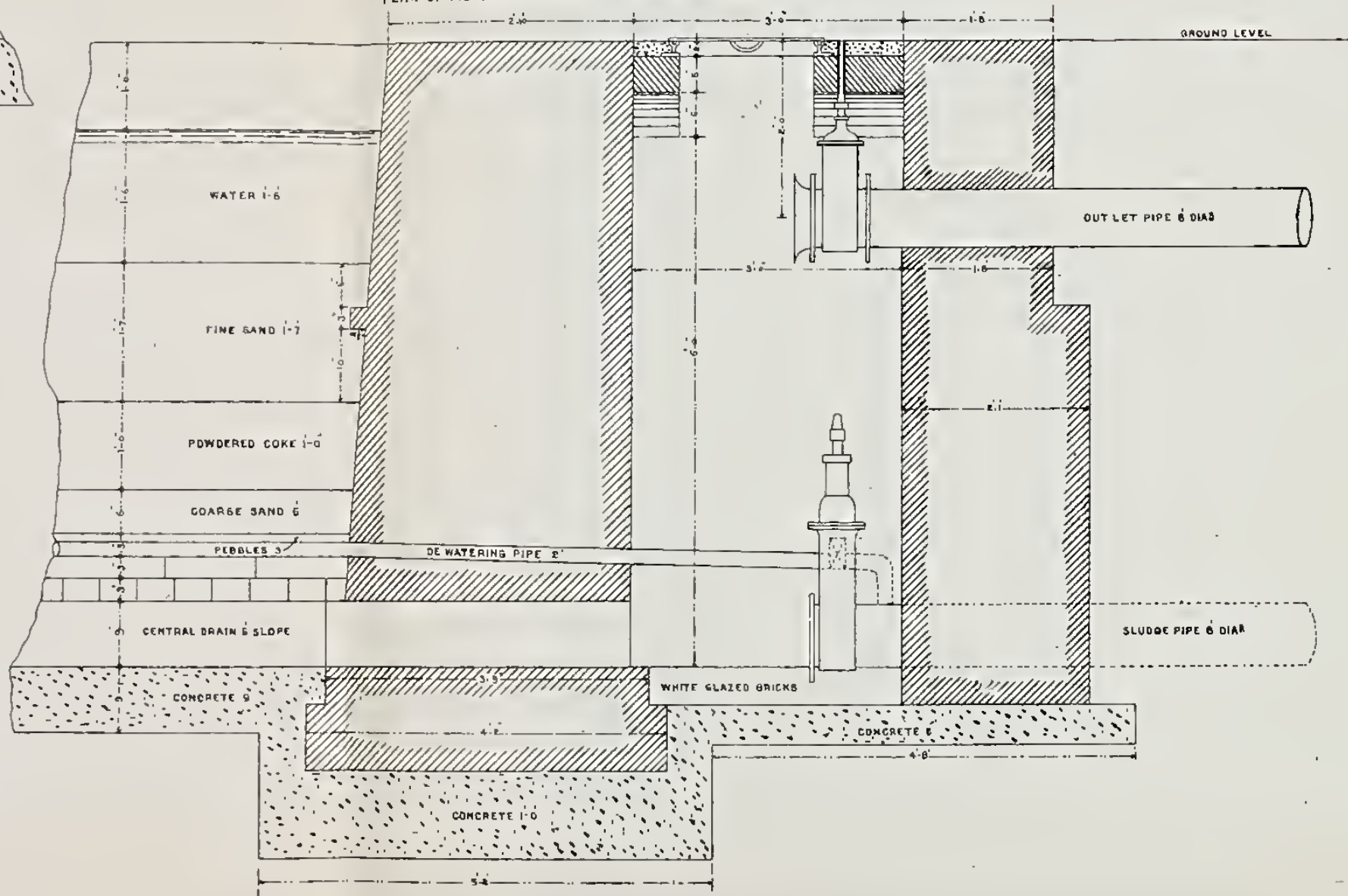

SECTION OF SPREADER

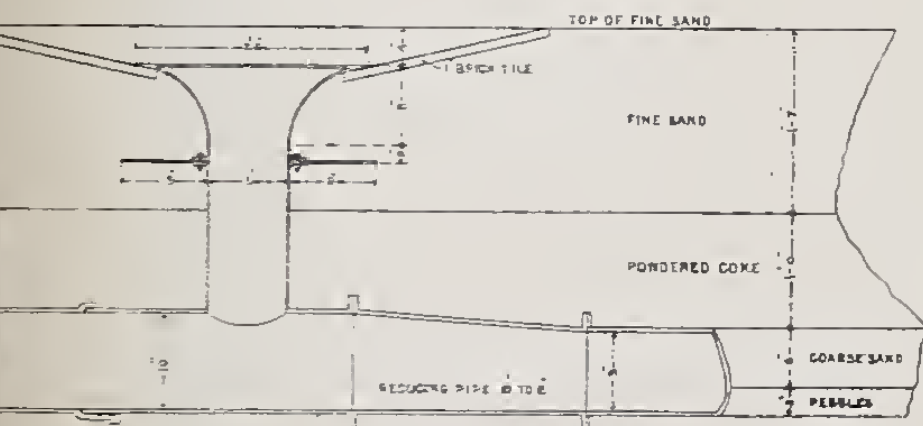



# HOWRAH WATER WORK

## PLAN OF CLEAR WATER RESERVOIR

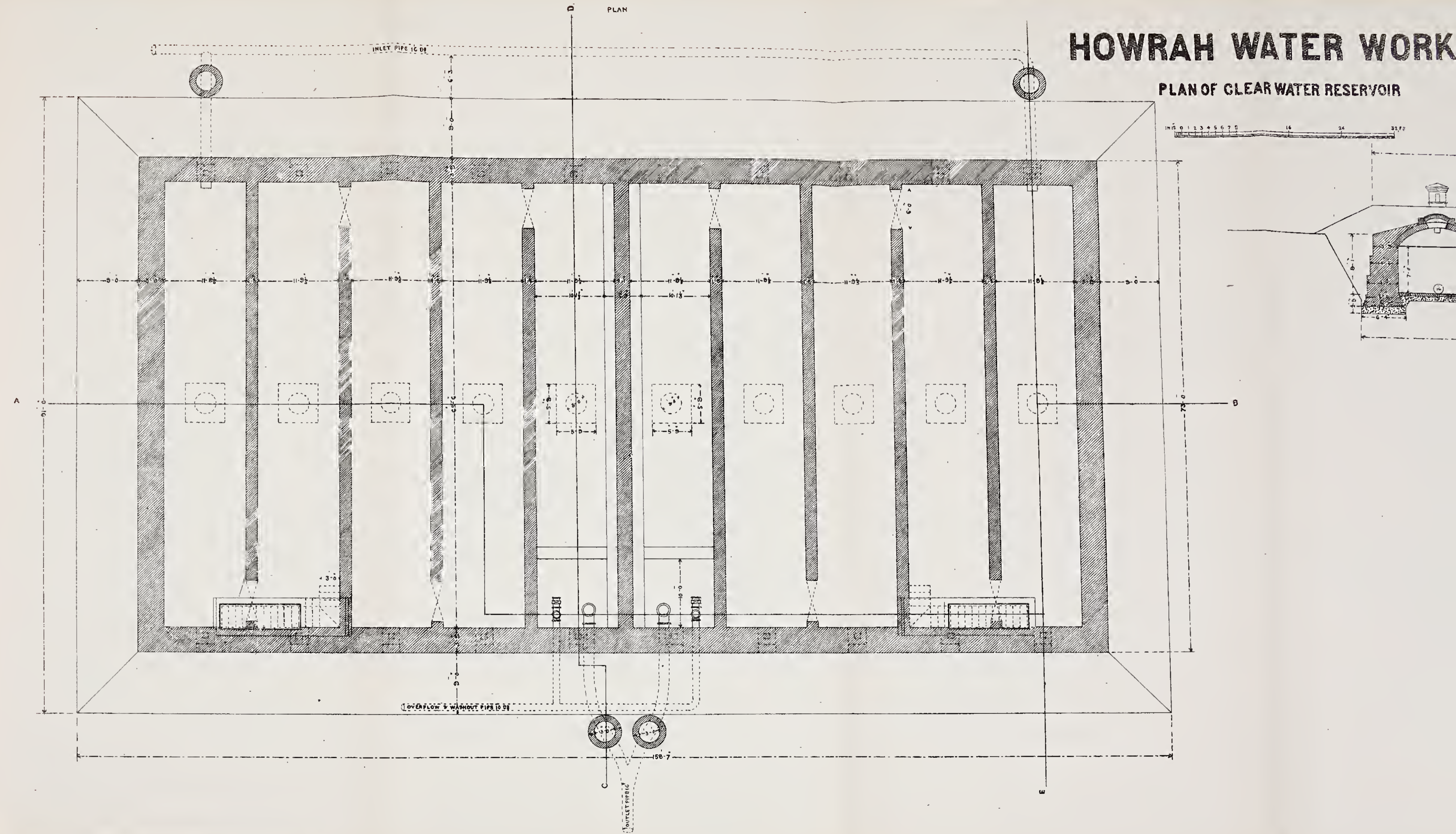

# ATER WORKS.

## R WATER RESERVOIR

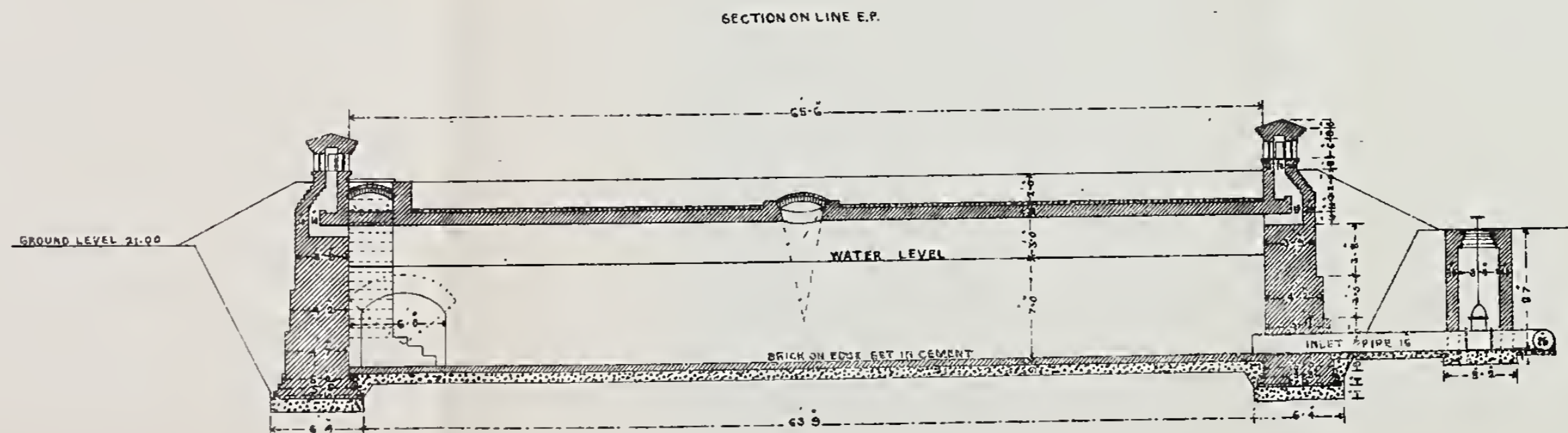
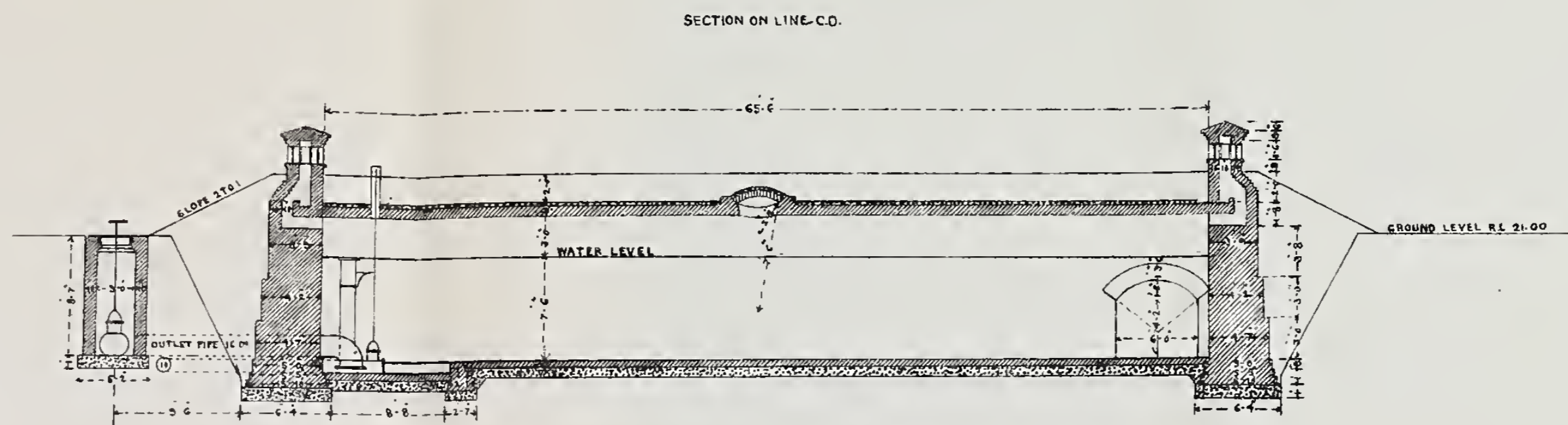
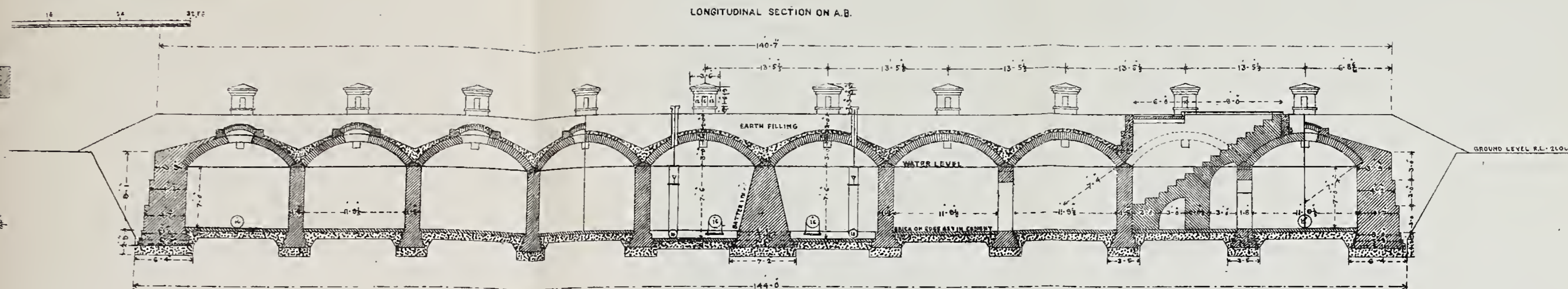

BERHAMPORE WATER WORKS

ELEVATED RESERVOIR 47 1/2 DIAM

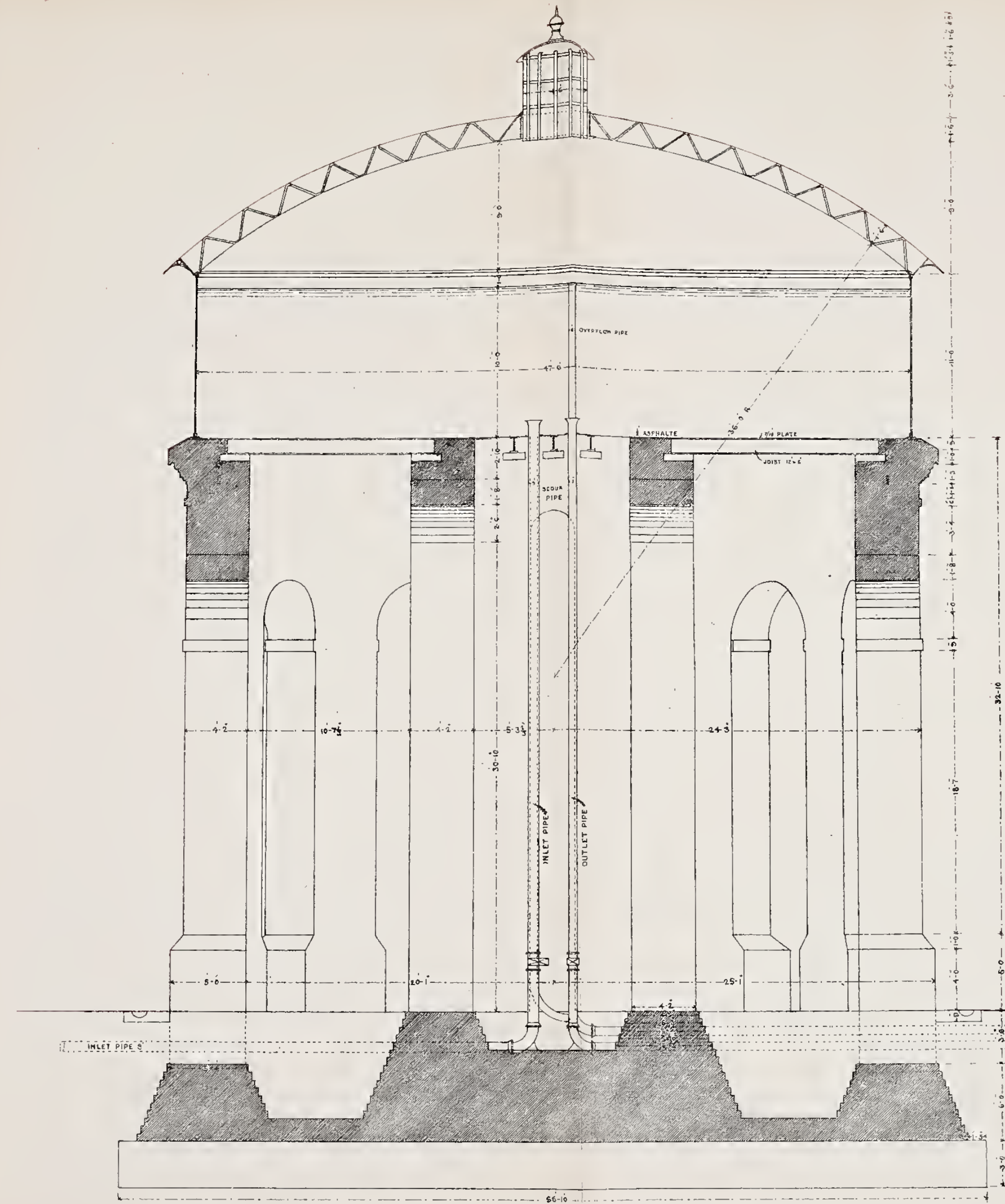
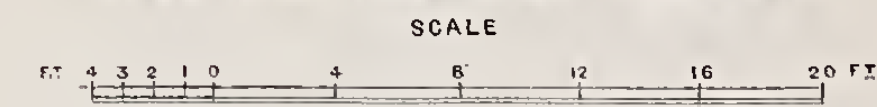

SECTION ON A.B

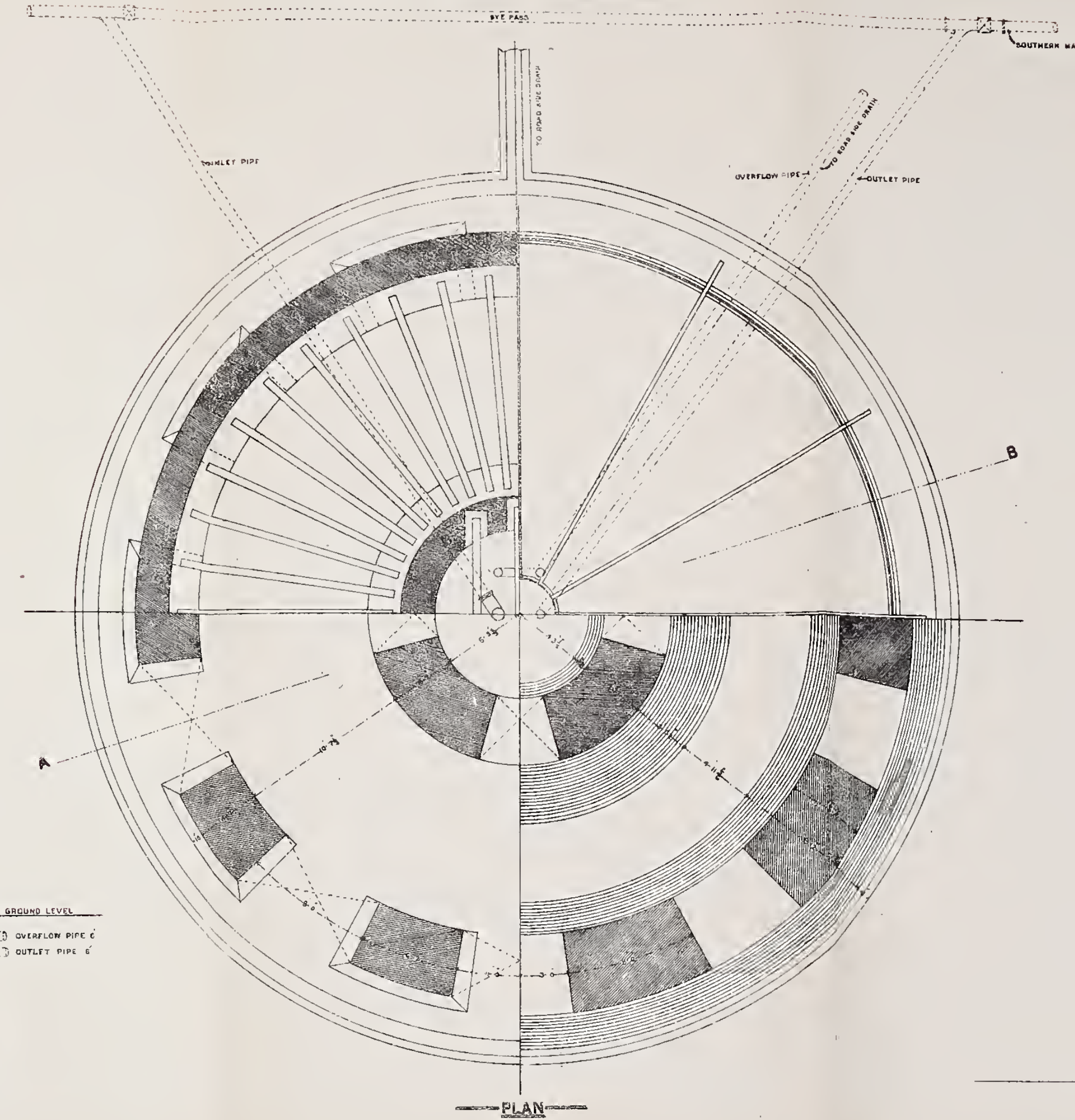

PLAN

SOUTHERN MAIN & DIAE

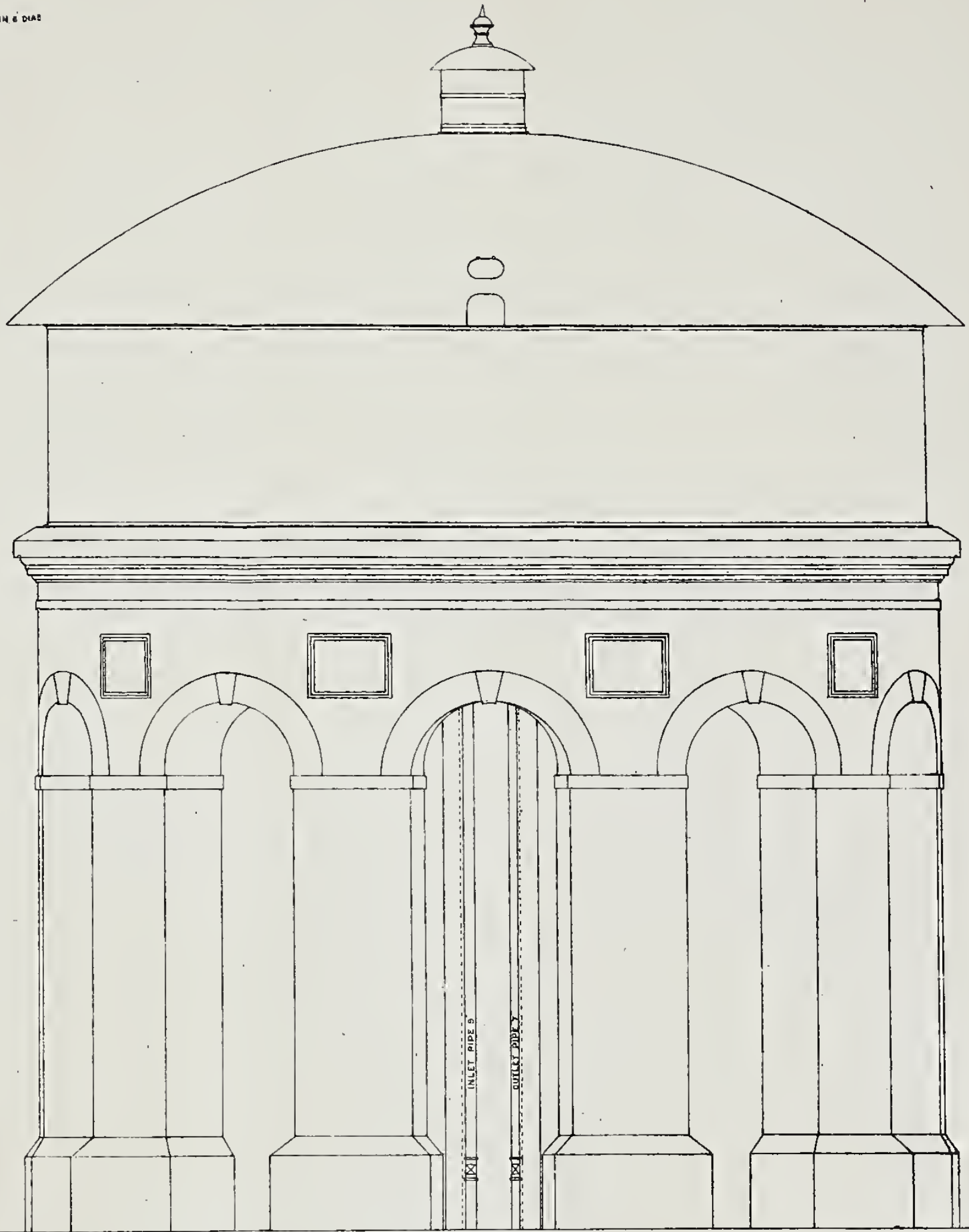

ELEVATION

Photo., S. I. O., Calcutta.





# SURFACE DRAIN SECTIONS



NOTE: BATTER OF SIDE WALLS = 1 IN 2.4

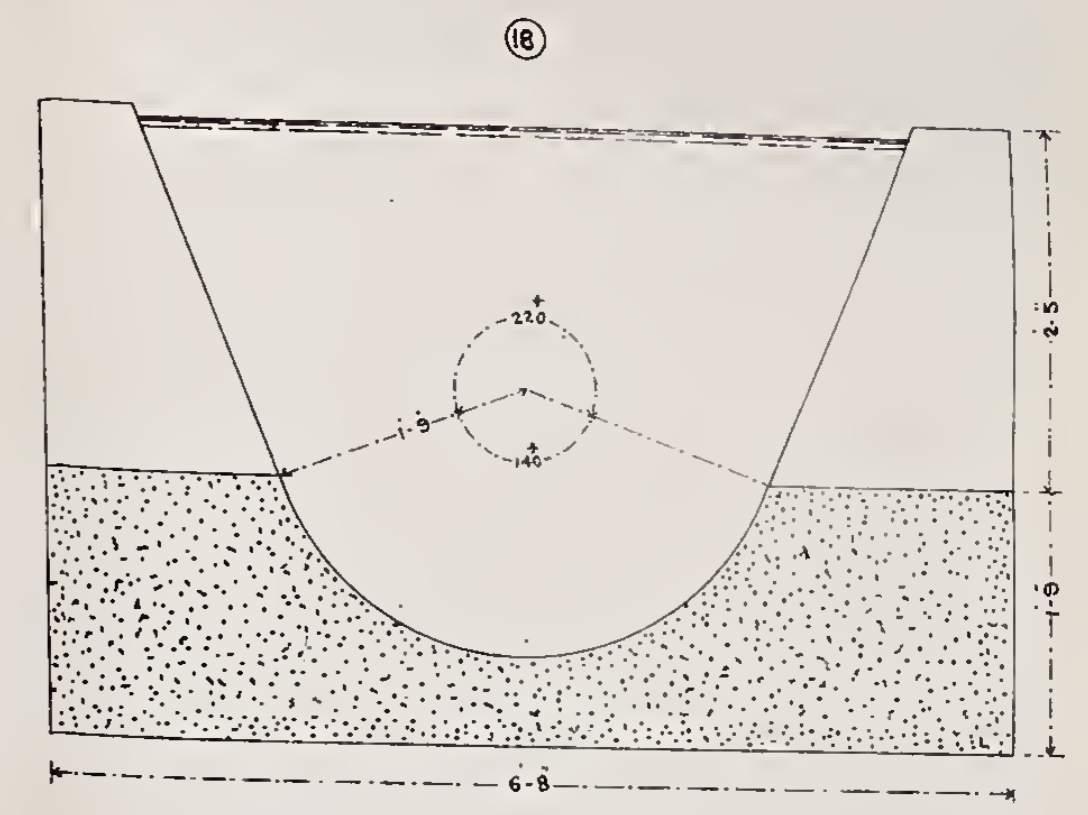
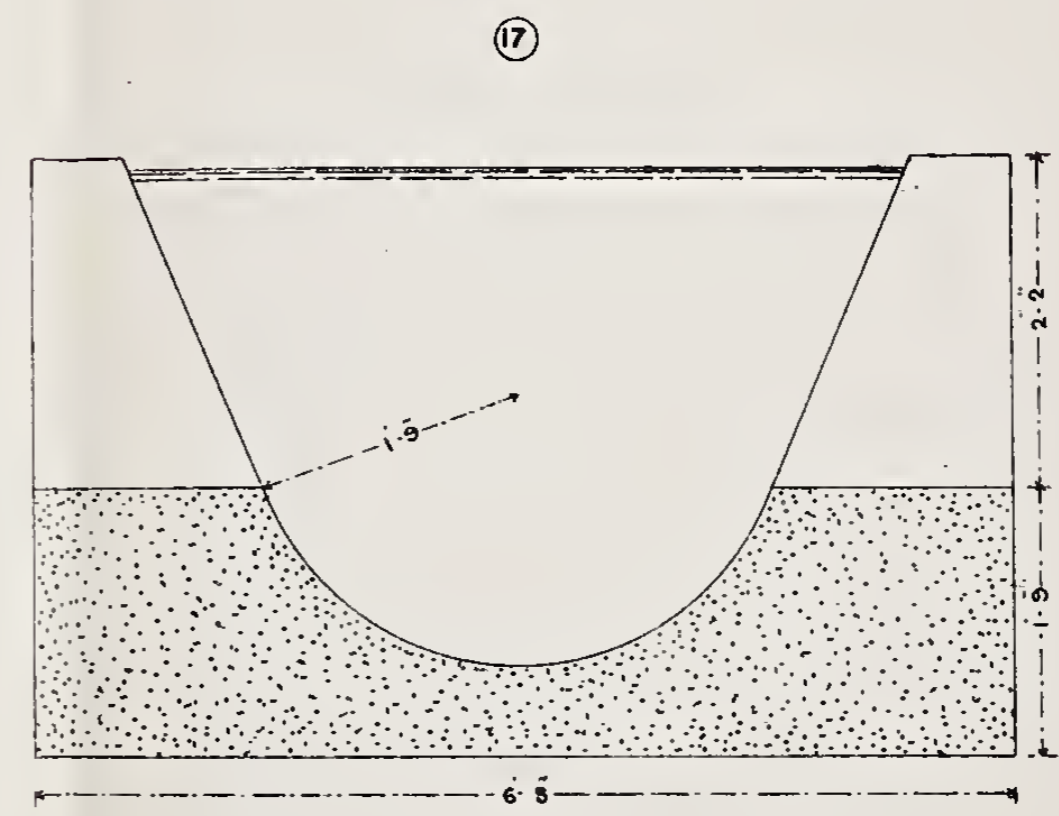
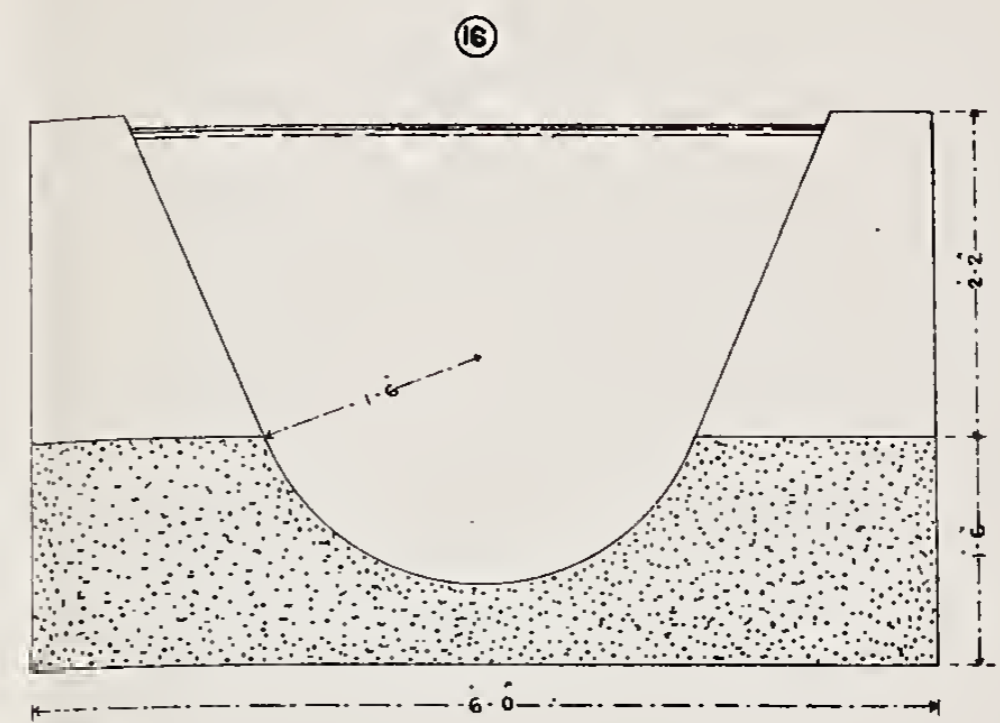
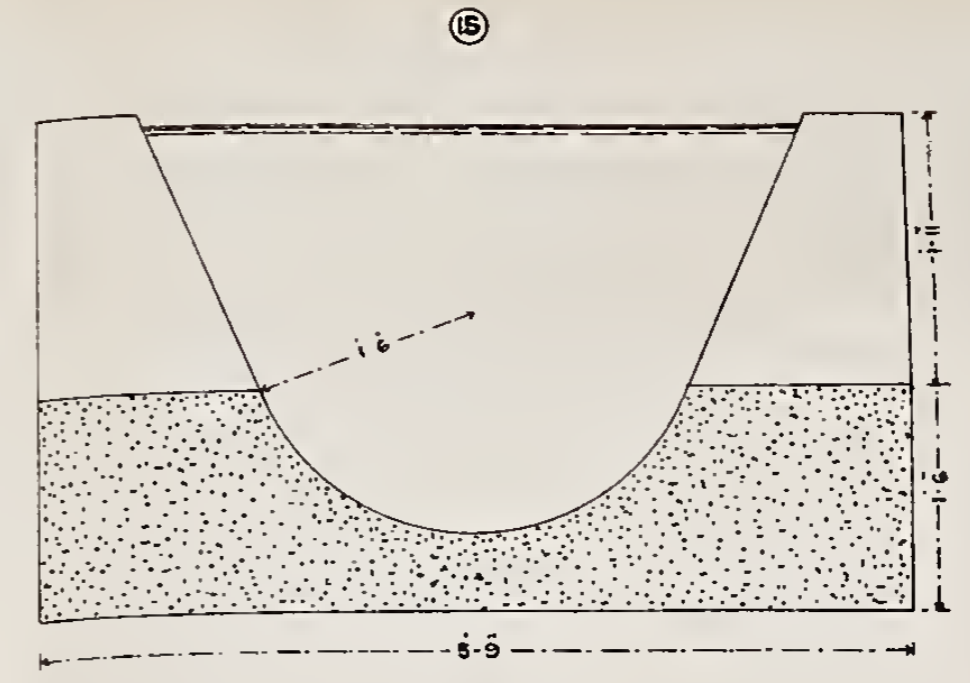
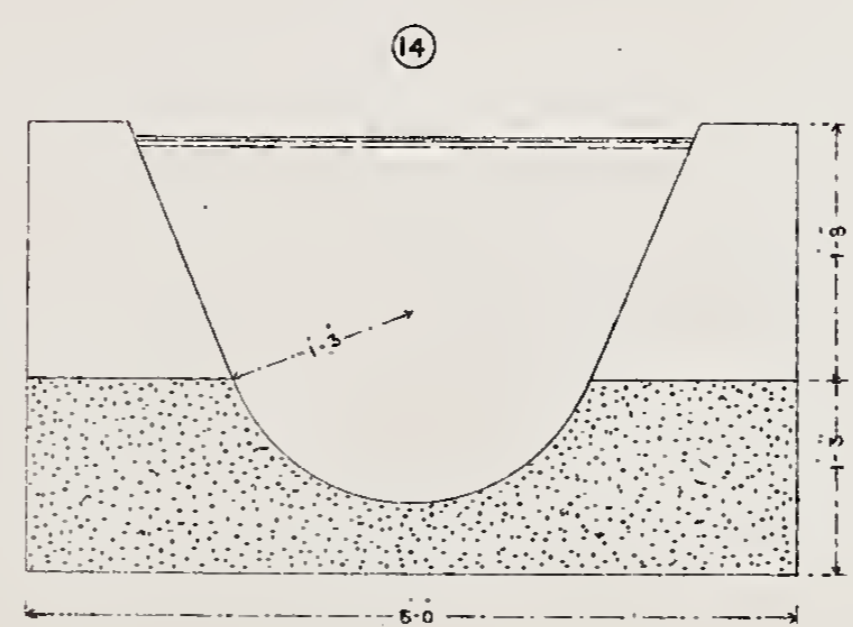
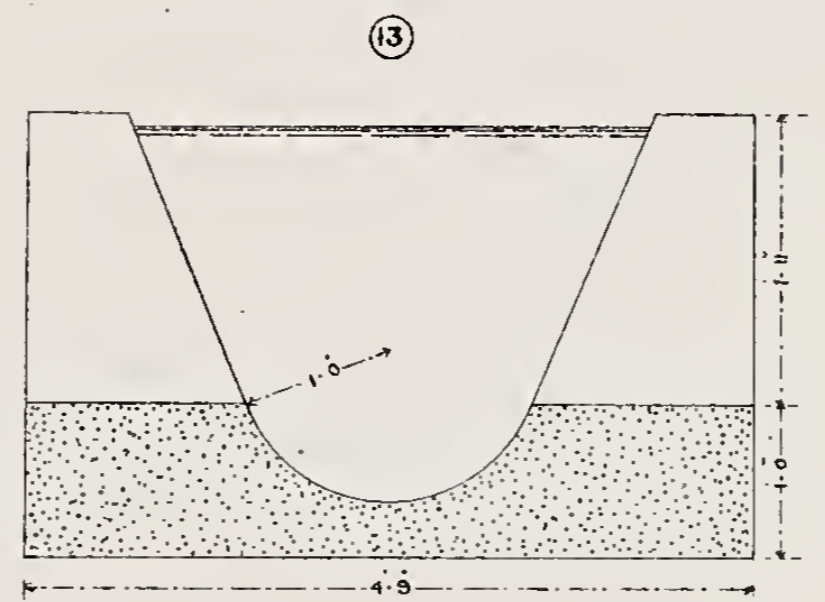
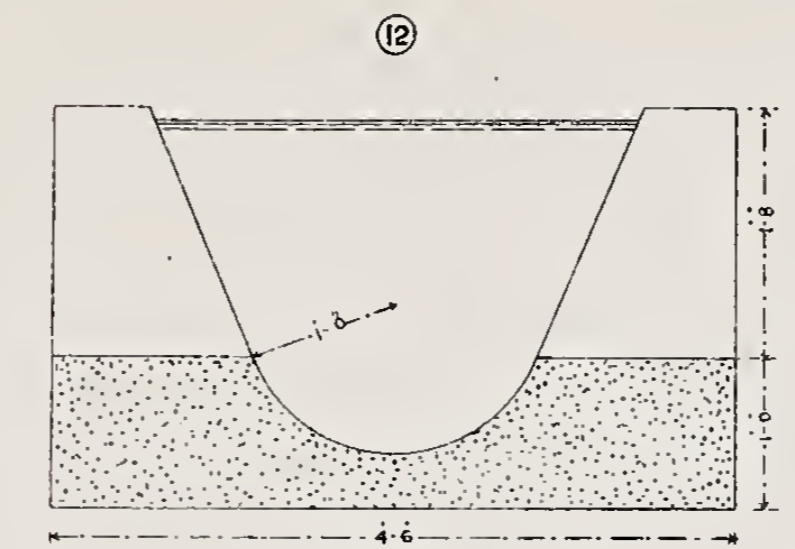
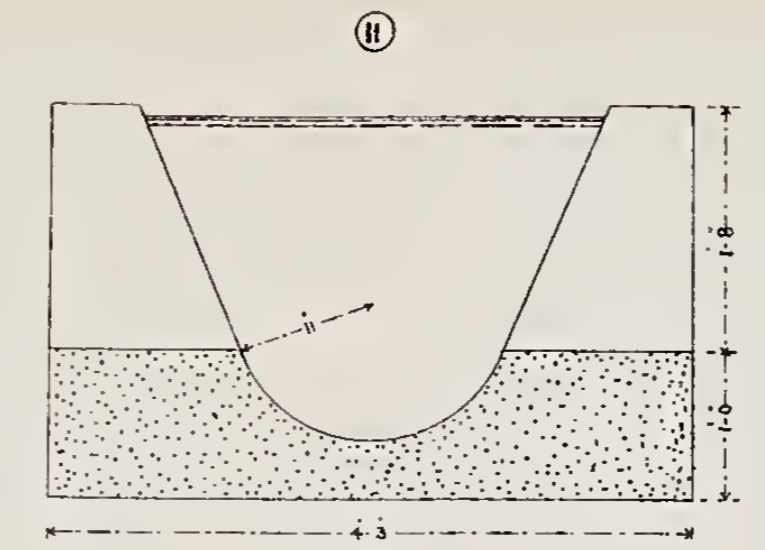
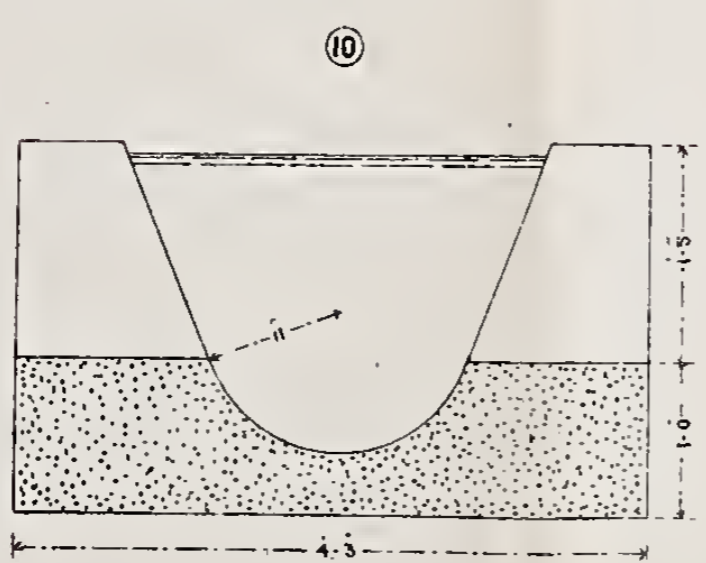
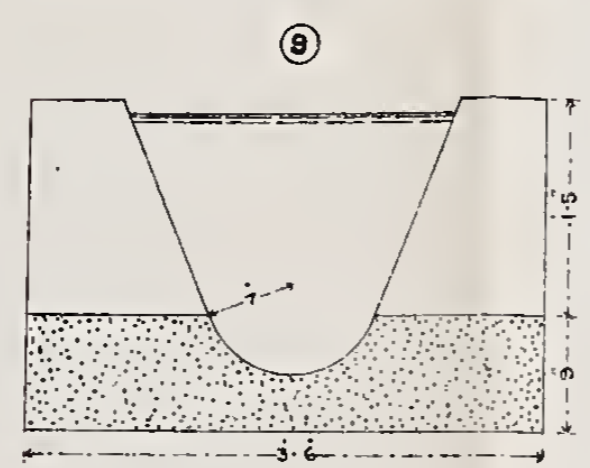
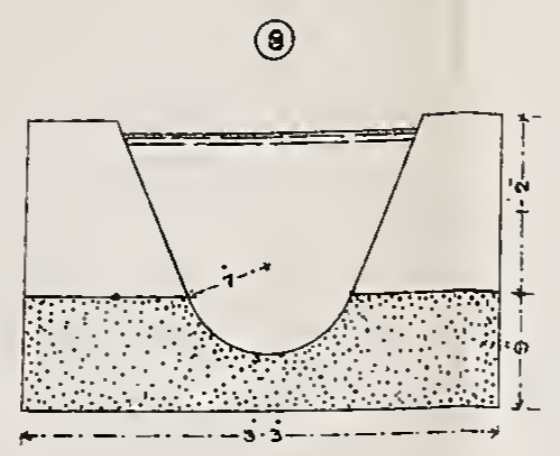
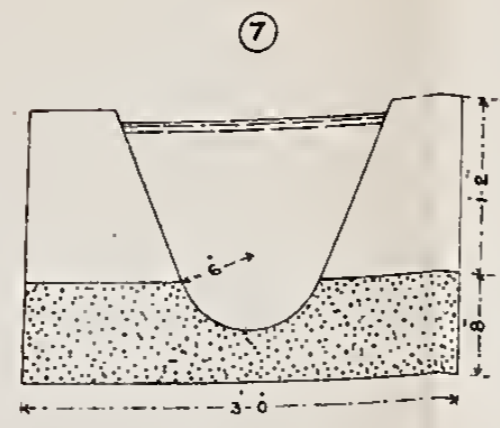
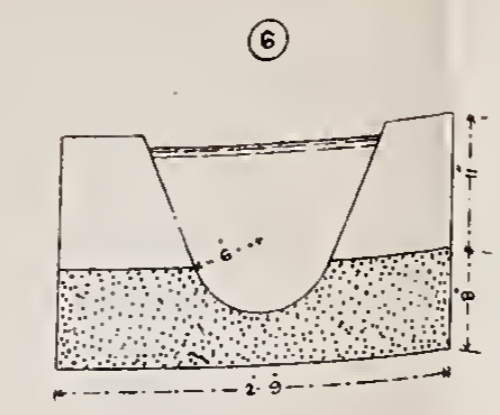
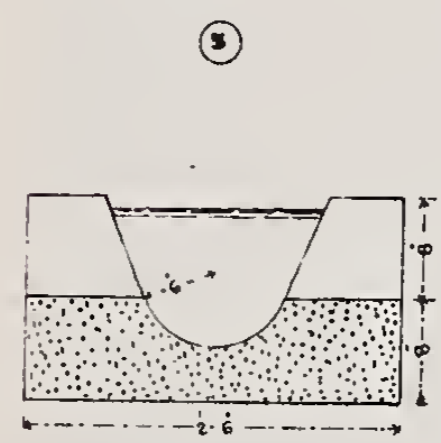
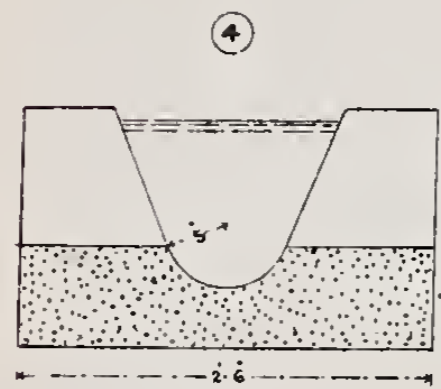
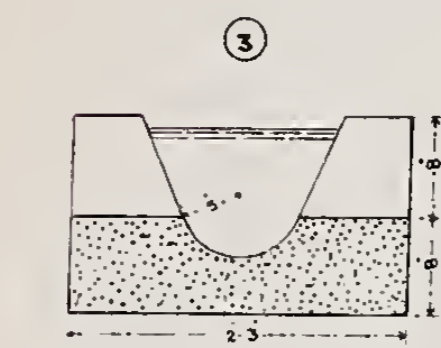
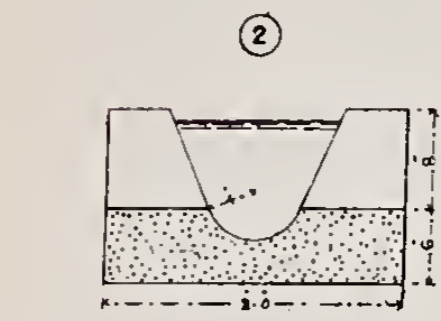
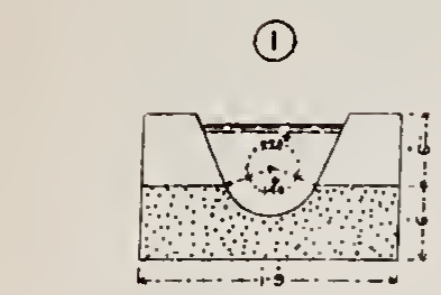





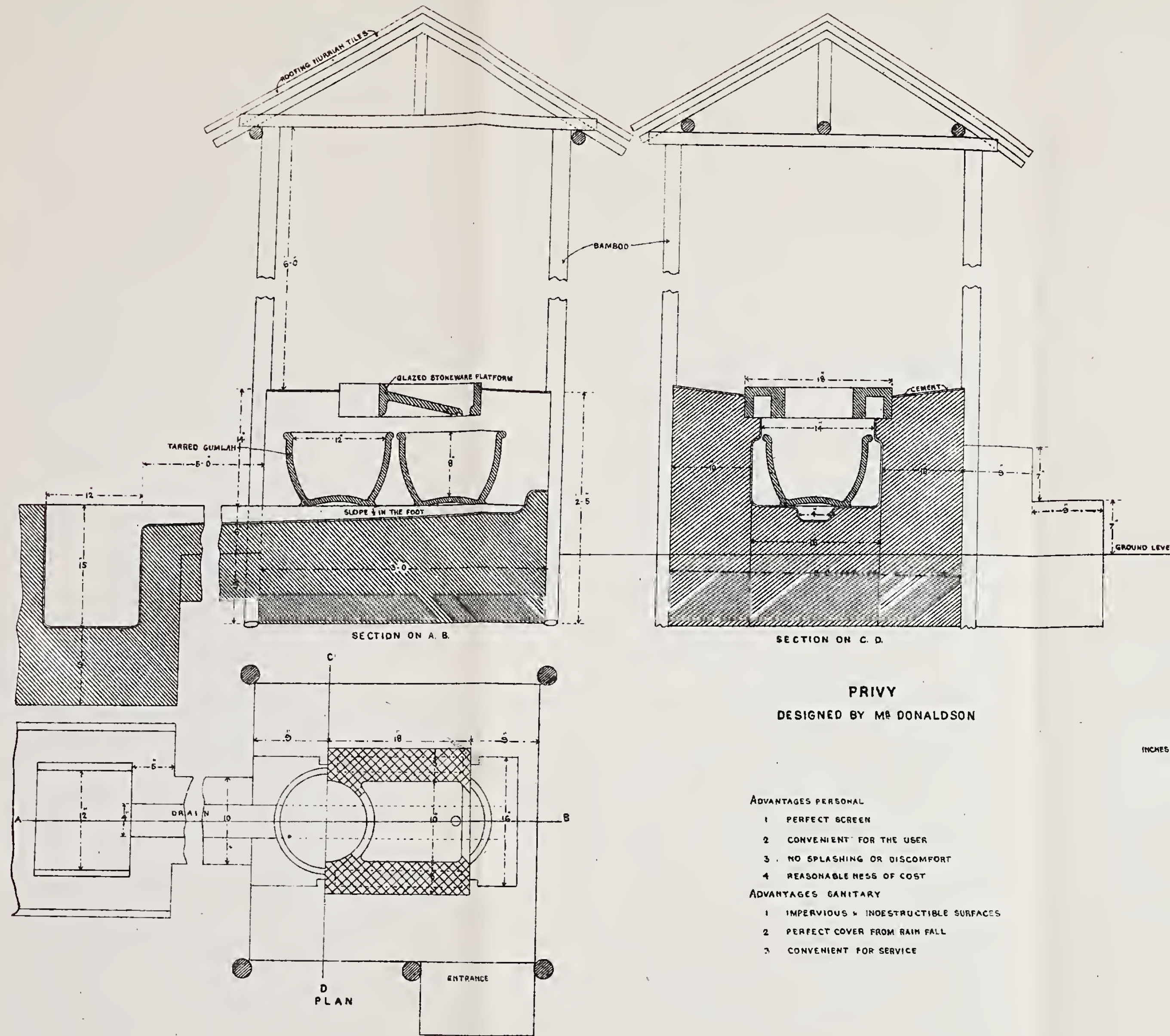

**PRIVY**  
DESIGNED BY MR DONALDSON

- ADVANTAGES PERSONAL
- 1 PERFECT SCREEN
  - 2 CONVENIENT FOR THE USER
  - 3 NO SPLASHING OR DISCOMFORT
  - 4 REASONABLENESS OF COST
- ADVANTAGES SANITARY
- 1 IMPERVIOUS & INDESTRUCTIBLE SURFACES
  - 2 PERFECT COVER FROM RAIN FALL
  - 3 CONVENIENT FOR SERVICE

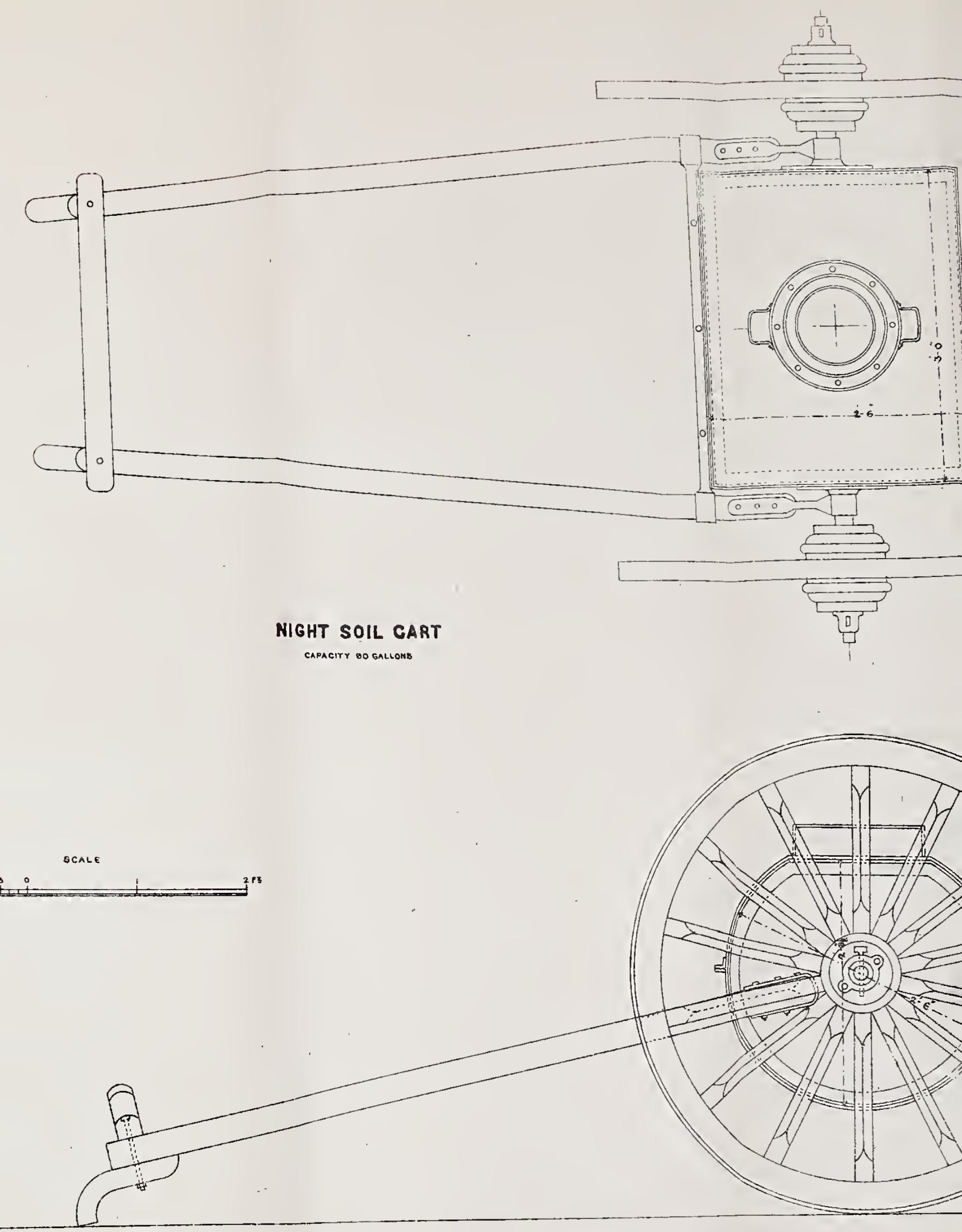

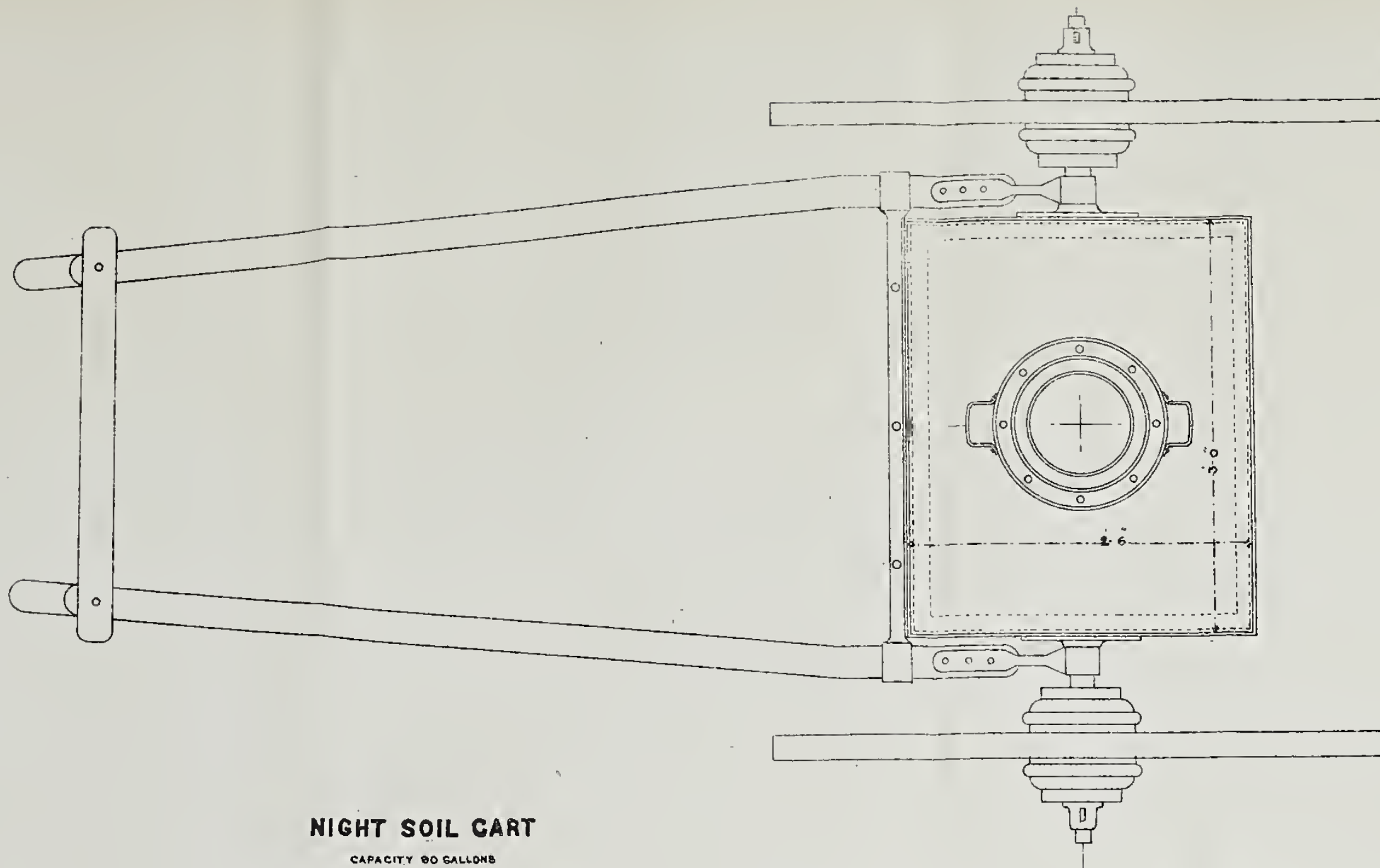

**NIGHT SOIL CART**

CAPACITY 60 GALLONS

