



DUDLEY KNOX LIBRARY
NAVAL POSTGRADUATE SCHOOL
MONTHLY CALLS: 98948-8002

NAVAL POSTGRADUATE SCHOOL

Monterey, California



THESIS

MICROCOMPUTER CONTROL
OF A
HYDRAULICALLY ACTUATED PISTON

by

Ian Grunther

June 1987

Thesis Advisor

R. H. Nunn

Approved for public release; distribution is unlimited.

T233086

REPORT DOCUMENTATION PAGE

1a REPORT SECURITY CLASSIFICATION Unclassified		1b RESTRICTIVE MARKINGS	
2a SECURITY CLASSIFICATION AUTHORITY		3 DISTRIBUTION/AVAILABILITY OF REPORT Approved for public release distribution is unlimited	
2b DECLASSIFICATION/DOWNGRADING SCHEDULE		4 PERFORMING ORGANIZATION REPORT NUMBER(S)	
5 MONITORING ORGANIZATION REPORT NUMBER(S)		6a NAME OF PERFORMING ORGANIZATION Naval Postgraduate School	
6b OFFICE SYMBOL (If applicable) 69		7a NAME OF MONITORING ORGANIZATION Naval Postgraduate School	
6c ADDRESS (City, State, and ZIP Code) Monterey, CA 93943		7b ADDRESS (City, State, and ZIP Code) Monterey, CA 93943	
8a NAME OF FUNDING/SPONSORING ORGANIZATION		8b OFFICE SYMBOL (If applicable)	
9 PROCUREMENT INSTRUMENT IDENTIFICATION NUMBER		10 SOURCE OF FUNDING NUMBERS	
8c ADDRESS (City, State, and ZIP Code)		PROGRAM ELEMENT NO	PROJECT NO
		TASK NO	WORK UNIT ACCESSION NO
11 TITLE (Include Security Classification) MICROCOMPUTER CONTROL OF A HYDRAULICALLY ACTUATED PISTON			
12 PERSONAL AUTHOR(S) Grunther, Ian			
13a TYPE OF REPORT Master's Thesis	13b TIME COVERED FROM _____ TO _____	14 DATE OF REPORT (Year Month Day) 1987, June	15 PAGE COUNT 54
16 SUPPLEMENTARY NOTATION			
17 COSATI CODES		18 SUBJECT TERMS (Continue on reverse if necessary and identify by block number)	
FIELD	GROUP	SUB-GROUP	
		Microcomputer control, microprocessor control, computer control, digital control, hydraulic systems, modeling.	
<p>This thesis is a study of a computer controlled hydraulically actuated piston. The system uses a Hewlett Packard HP85B microcomputer as a controller. Included in this research is a detailed computer simulation of the system with laboratory validation. This effort supports the overall goal of complete study of microcomputer control of electrohydraulic power systems by the establishment and simulation modeling of a baseline system. Special emphasis is placed on modeling the effects of the computer on overall system performance. It was found that sample period is one of the most important factors influencing the ability to control a hydraulic power element using a microcomputer. Proper selection of the sampling period alone is not always sufficient to insure the ability to control the plant. Other factors such as non-linearities in the plant may influence the ability to use a digital controller.</p>			
20 DISTRIBUTION/AVAILABILITY OF ABSTRACT <input type="checkbox"/> UNCLASSIFIED/UNLIMITED <input checked="" type="checkbox"/> SAME AS RPT <input type="checkbox"/> DTIC USERS		21 ABSTRACT SECURITY CLASSIFICATION Unclassified	
22a NAME OF RESPONSIBLE INDIVIDUAL Robert H. Nunn		22b TELEPHONE (Include Area Code) 408-646-2033	22c OFFICE SYMBOL 69xh

Approved for public release; distribution is unlimited.

Microcomputer Control
of a
Hydraulically Actuated Piston

by

Ian Grunther
Lieutenant, United States Coast Guard
B.S., United States Coast Guard Academy, 1980

Submitted in partial fulfillment of the
requirements for the degree of

MASTER OF SCIENCE IN MECHANICAL ENGINEERING

from the

NAVAL POSTGRADUATE SCHOOL
June 1987

ABSTRACT

This thesis is a study of a computer controlled hydraulically actuated piston. The system uses a Hewlett Packard HP85B microcomputer as a controller. Included in this research is a detailed computer simulation of the system with laboratory validation. This effort supports the overall goal of complete study of microcomputer control of electrohydraulic power systems by the establishment and simulation modeling of a baseline system. Special emphasis is placed on modeling the effects of the computer on overall system performance. It was found that sample period is one of the most important factors influencing the ability to control a hydraulic power element using a microcomputer. Proper selection of the sampling period alone is not always sufficient to insure the ability to control the plant. Other factors such as non-linearities in the plant may influence the ability to use a digital controller.

Thesis
G8823
C

THESIS DISCLAIMER

The reader is cautioned that computer programs developed in this research may not have been exercised for all cases of interest. While every effort has been made, within the time available, to ensure that the programs are free of computational and logic errors, they cannot be considered validated. Any application of these programs without additional verification is at the risk of the user.

TABLE OF CONTENTS

I.	INTRODUCTION	9
A.	BACKGROUND	9
	1. Advantages/Disadvantages of Hydraulic Systems	9
	2. Advantages of Digital Microprocessor Control	10
	3. Previous Thesis Work	11
B.	OBJECTIVES	11
C.	APPROACH	12
II.	ANALOG SYSTEM	13
A.	DESCRIPTION OF THE SYSTEM	13
B.	COMPONENT EQUATIONS	14
	1. ServoValve Dynamics	14
	2. Piston Dynamics	17
	3. Load Dynamics	17
C.	ANALOG SYSTEM MODEL	18
D.	ANALYSIS OF THE SYSTEM	19
E.	FREQUENCY RESPONSE TEST	23
F.	MODEL VALIDATION	23
III.	DIGITAL SYSTEM	27
A.	DESCRIPTION OF THE SYSTEM	27
B.	DIGITAL COMPONENT EQUATIONS	28
	1. Application of the Analog Component Equations	28
	2. Computer System Dynamics	28
C.	DIGITAL SYSTEM MODEL	31
D.	MODEL VALIDATION	32
IV.	CONCLUSIONS AND RECOMMENDATIONS FOR FOLLOW ON WORK	35
A.	CONCLUSIONS	35

B.	RECOMMENDATIONS FOR FOLLOW ON WORK	35
1.	Valve Linearization	35
2.	Plant Characterization	35
3.	Model Supply and Return Pressure Dynamics	36
4.	State Space Modeling	36
5.	Influence of Temperature on System Performance	36
6.	Data Acquisition System	36
APPENDIX A:	ANALOG SIMULATION CODE (DSL)	37
APPENDIX B:	ANALOG MODEL VALIDATION DATA	40
APPENDIX C:	MICROCOMPUTER CONTROL SYSTEM ALGORITHM (BASIC)	43
APPENDIX D:	DIGITAL SYSTEM SIMULATION CODE (DSL)	44
APPENDIX E:	DIGITAL LOGIC TEST DATA	47
	LIST OF REFERENCES	52
	INITIAL DISTRIBUTION LIST	53

LIST OF FIGURES

2.1	Analog System	13
2.2	Servoamplifier	15
2.3	Servoamplifier Gain	15
2.4	Analog System Block Diagram	19
2.5	Closed Loop Analog System Block Diagram	21
2.6a	Closed Loop Frequency Response (Amplitude)	24
2.6b	Closed Loop Frequency Response (Phase)	24
2.7	Analog System Step Response (0.195 in.)	26
2.8	Analog Step Step Response (1.785 in.)	26
3.1	System with Digital Controller	28
3.2	Microcomputer Controller	30
3.3	Digital System Model	32
B.1	Analog System Step Response (0.4088 in.)	40
B.2	Analog System Step Response (0.635 in.)	40
B.3	Analog System Step Response (0.8625 in.)	41
B.4	Analog System Step Response (1.11 in.)	41
B.5	Analog System Step Response (1.32 in.)	42
B.6	Analog System Step Response (1.57 in.)	42

ACKNOWLEDGEMENTS

The author would like to express his deep appreciation for the dedication, patience, and insightful guidance given by Professor Robert H. Nunn in support of this thesis effort. The author would also like to thank Mr. Tom Christian for his technical support during critical times of need. Last but in no way least the author thanks his wife Elaine who's love and moral support made the completion of the thesis effort possible.

I. INTRODUCTION

A. BACKGROUND

Hydraulic systems in one form or another have been around for a long time. These systems have historically relied upon humans in the open loop case or analog electrical circuits in the closed loop case for system control. In recent years however a quiet revolution has been taking place in the hydraulic systems industry. With the current rapid advances in digital technology hydraulic systems are fast becoming fertile ground for the application of digital control. Not only are digital circuits being designed for standard control functions but with the advent of microprocessors these circuits are becoming "thinking" controllers. It is this trend which motivates the detailed study of microprocessor controlled hydraulic systems.

The Department of Mechanical Engineering has begun a continuing program of study on the subject of microprocessor control of electrohydraulic servomechanisms. The overall objective of the work is to provide some of the insights necessary for the establishment of a comprehensive and systematic framework embodying the design of microprocessor-controlled electrohydraulic servomechanisms. This thesis study follows the initial work done by Finch [1] in an effort to achieve this objective.

1. Advantages/Disadvantages of Hydraulic Systems

Hydraulic systems offer several unique advantages over other power devices. These systems are well suited for applications where low component weight, high accuracy, and heavy load movement is required. Merritt [2] states the following specific advantages of hydraulic systems:

1. Smaller, lighter more compact components.
2. Hydraulic fluid acts as a lubricant which extends component life.
3. There is no phenomenon in hydraulic components comparable to the saturation and losses in magnetic materials of electrical machines.
4. Hydraulic actuators have a higher speed of response with fast starts, stops, and speed reversals possible.
5. Hydraulic actuators may be operated under continuous, intermittent, reversing, and stalled conditions without damage.
6. Hydraulic actuators have a higher stiffness so there is little drop in speed as loads are applied.

7. Open and closed loop control of hydraulic actuators is relatively simple using valves and pumps.

There are some disadvantages to the use of hydraulic systems and no discussion would be complete without at least mentioning them. Merritt [2] lists these shortcomings as follows:

1. Hydraulic power is not as conveniently available as electrical power.
2. Small allowable tolerances result in high costs for the manufacture of hydraulic components.
3. The hydraulic fluid imposes an upper temperature limit.
4. Hydraulic fluid may present a fire hazard.
5. Hydraulic systems are messy.
6. Hydraulic systems are susceptible to failure due to dirt or contamination of the fluid.

Although these disadvantages may preclude the use of a hydraulic system in some specific applications, their widespread use attests to their versatility and usefulness. Hydraulic systems are of the most use in applications where relatively high power levels are required especially within confined spaces. This explains their widespread use in aircraft control surface positioning, fin stabilizer positioning on ships, and even as a means of propulsion in special applications such as on some SWATH vessels.

2. Advantages of Digital Microprocessor Control

Until recently hydraulic systems have relied upon analog circuitry for control. More and more these systems are being manufactured with digital control. One would logically ask what advantages this offers over the proven analog controller. Aside from the increase in reliability and decrease in signal voltages necessary, the major advantage to digital control is the ability to incorporate a microprocessor in the circuit. This improvement broadens the range of functions that may be included in the control loop. Henke [3] lists the following new functions for the controller:

1. Closing the loop, replacing the analog summing point and conditioning the error signal.
2. Pre-loop processing
3. Peripheral Processing
4. Adaptive Control
5. Smart Redundancy
6. Time Optimal Control

Along with increasing the range of applications there are other major advantages to the use of digital microprocessor control circuits for hydraulic systems. No doubt a leading advantage is cost. As the complexity of the control system rises analog control circuitry costs rise dramatically. Although this trend is seen with digital systems the rise in cost is less dramatic. In addition, the cost of changing an analog control circuit once in place is much greater than a digital circuit which incorporates a microprocessor [4].

Another major advantage of digital microprocessor control is flexibility. While analog circuits may require component changes and rewiring, digital microprocessor circuits may require only reprogramming. This may be accomplished by either keyboard entry or by simply reprogramming a memory chip. This reduces the time and cost of making changes to the control system. It may also enable the overall system to be used for several functions rather than one specialized task.

3. Previous Thesis Work

In Ref. 1, Finch reports the results of his study of a microcomputer controlled hydraulic motor. He used a 512K Macintosh computer and a product of GW Instruments called MacADIOS as an interface to control a hydraulic system consisting of a hydraulic power source, servovalve and hydraulic motor. In this work the computer was used for both open and closed loop signal processing and conditioning. Finch was successful in implementing the computer as a system controller and establishing a baseline system for follow-on work. He used Dynamic Simulation Language (DSL) programs to predict system performance but his analysis did not include any digital microprocessor dynamics in these simulations.

B. OBJECTIVES

Finch made several recommendations for follow on work. One of these was that piston actuator systems be studied in further detail since "a large variety of hydraulic systems involve the positioning of loads using a piston-type arrangement." One of the main objectives of this thesis effort has been to study the hydraulically controlled piston response in detail. A Hewlett Packard HP85B microcomputer has been used as the system controller. An additional objective was to model the computer dynamics for a more accurate simulation of the overall system.

C. APPROACH

To begin the study a thorough understanding of the analog system was sought. This began with a dissection of the system into individual components so that a linear mathematical model could be developed for each. The component equations were then combined and coded in a simulation using DSL. Step input performance predicted by the simulation was verified by lab testing. Once the analog system was fully understood and confidence was gained with the simulation a microcomputer control system was added. Adding this system required the construction of a digital or discrete time model to represent it. This was then combined with the analog model to develop the overall digital system simulation.

II. ANALOG SYSTEM

A. DESCRIPTION OF THE SYSTEM

The test bench set up used for experimentation includes: a hydraulic power source (10 gpm @ 1000 psi), a Vickers SM4-15 flapper nozzle piloted servovalve, a Sheffer double-acting hydraulic piston (with 6 inches of travel), and a Vickers servoamplifier with a built in regulated power supply. Figure (2.1) shows a simplified system drawing which represents the analog configuration.

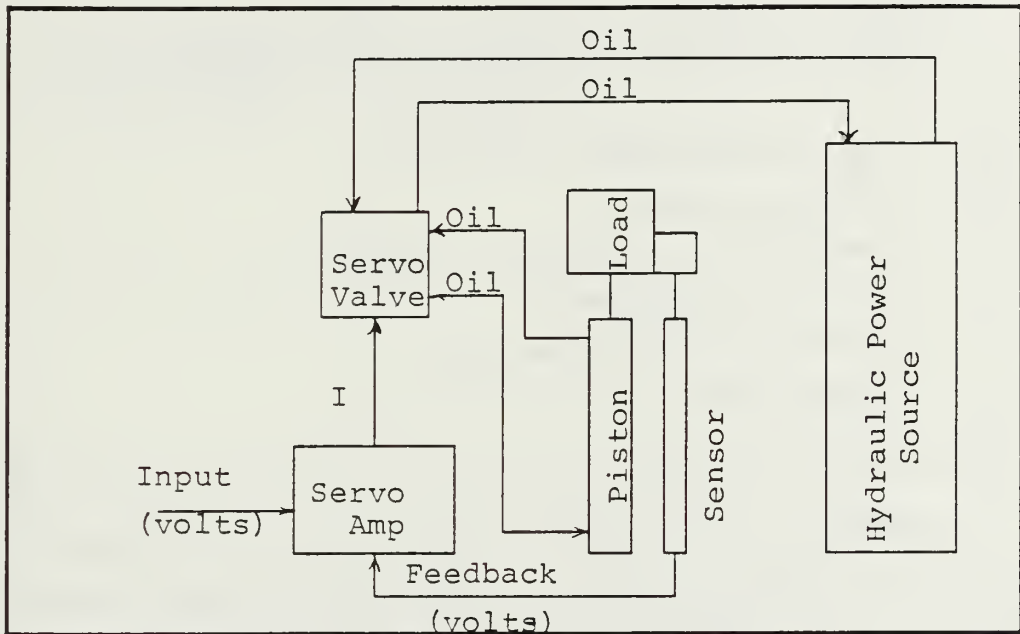

Figure 2.1 Analog System.

Figure (2.2) is a schematic representation of the servoamplifier. While the amplifier has many capabilities, only the power stage preamp and power stage output sections are used in this research. Reference and feedback voltages varying between +12 and -12 volts are applied to the power stage preamp input (terminals 4 and 5). These voltages are summed internally and the resulting error signal passes through the amplifier to the servovalve. The servovalve pilot-stage is driven by two 20 ohm coils in parallel which give it an equivalent resistance of 10 ohms. The current supplied to the servovalve is limited in the power stage preamp to 200 mA to prevent damage to the

coils. The power amplifier gain may be varied from 110 to 1520 mA/volt. Figure (2.3) shows the relationship between current output and voltage input of the servoamplifier at the two extremes of the amplifier gain.

B. COMPONENT EQUATIONS

1. ServoValve Dynamics

The servovalve used was found through experimentation to be slightly open centered but will be considered critically centered for the purposes of modeling. (The degree of open centered behavior is so slight that the more complicated model is not warranted.) The general equation describing the operation of a critically centered spool valve is:

$$Q_L = C_d w x_v (\rho)^{-1/2} (P_S - P_L)^{1/2} \quad (2.1)$$

- Q_L = flow through the load
- C_d = discharge coefficient
- w = area gradient
- x_v = valve spool displacement
- ρ = mass density of the hydraulic fluid
- P_S = supply pressure
- P_L = load pressure drop

Modification to Eq. (2.1) is necessary due to the difficulty in directly measuring valve spool movement. To reflect this, the following parameter which relates valve spool movement to current applied to the valve torque-motor coils, is defined:

$$K_V = \frac{C_d w}{(\rho)^{1/2}} \left(\frac{x_v}{I} \right) \quad (2.2)$$

With this substitution, Eq. (2.1) becomes:

$$Q_L = K_V I (P_S - P_L)^{1/2} \quad (2.3)$$

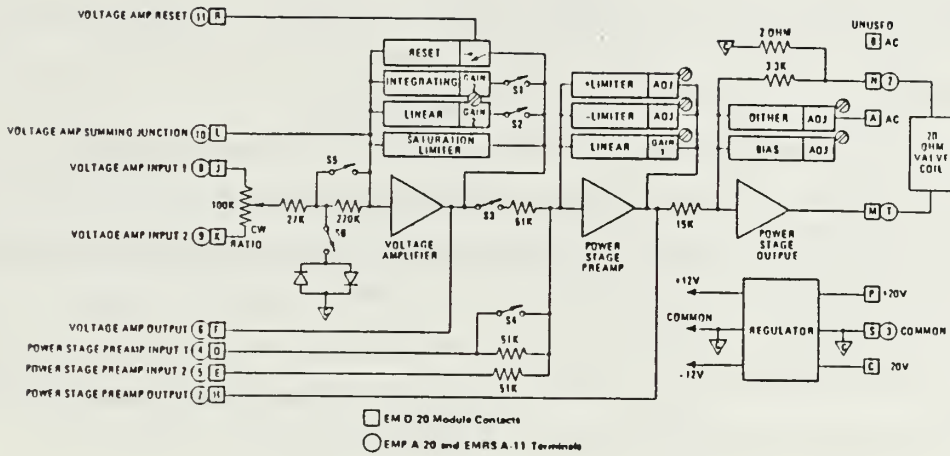

Figure 2.2 Servoamplifier.

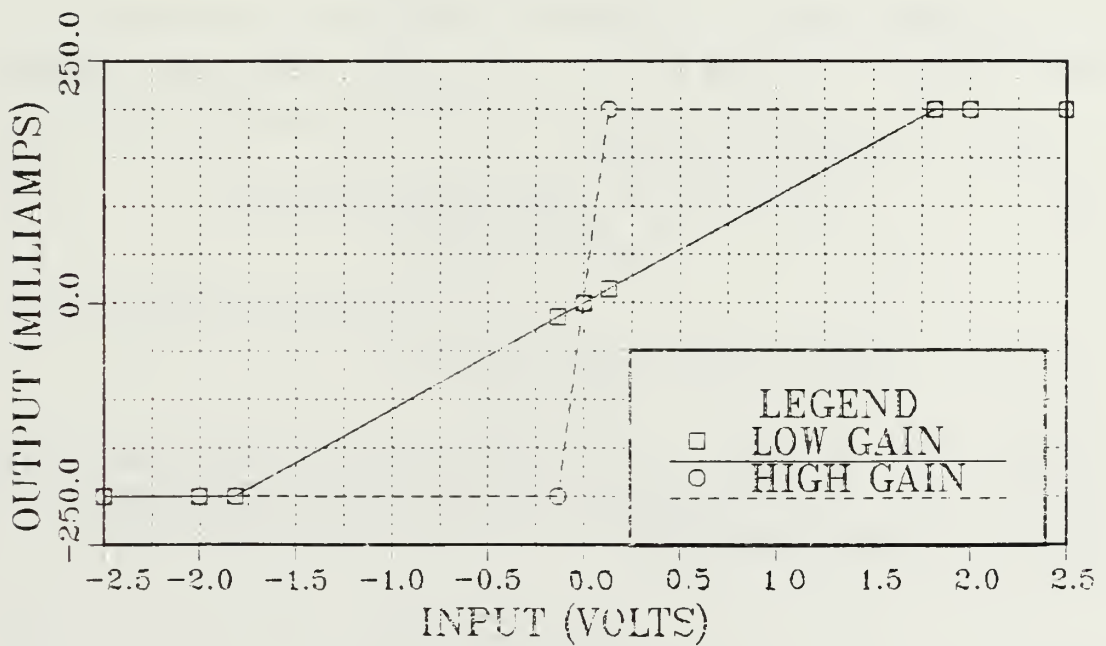

Figure 2.3 Servoamplifier Gain.

- K_v = valve current transfer coefficient
 $(3.52 \times 10^{-3} \text{ in}^3 / \text{sec} \cdot \text{ma} \cdot \text{psi}^{1/2})$
 I = current supplied to the valve

Note that the use of the modified valve current transfer coefficient presumes a linear relationship between the current supplied to the valve coils and valve spool position. Experiments have proven this to be a valid assumption.

Equation (2.3) must now be linearized to facilitate modeling and studies of system response. The no-load null valve spool position is chosen as the center point for the linearization. Reasons for this choice are "system operation usually occurs near this region, the valve flow gain is largest, giving high system gain, and the flow-pressure coefficient is smallest, giving a low damping ratio. Hence this operating point is the most critical from a stability viewpoint, and a system stable at this point is usually stable at all operation points." [2] The linearized form of Eq. (2.3) is:

$$Q_L = K_{qi} \Delta I - K_{ci} \Delta P_L \quad (2.4)$$

where

$$K_{qi} = K_v (P_s - P_L)^{1/2}$$

K_{qi} = modified null flow gain

$$K_{ci} = \frac{0.5 K_v \Delta I}{(P_s - P_L)^{1/2}}$$

K_{ci} = modified null flow pressure coefficient

Subscript 0 refers to conditions at the operating point and a Δ denotes departures from this point. Since we are linearizing about the null position, i.e. $Q_{L0} = 0$, $I_0 = 0$, and $P_{L0} = 0$, Eq. (2.4) may be written:

$$Q_L = K_{qi} I - K_{ci} P_L \quad (2.5)$$

2. Piston Dynamics

For the piston actuator the model suggested by Merritt [2] is adopted as follows:

$$Q_L = A_p \dot{x}_p + C_{tp} P_L + \frac{V_t P_L}{4 \beta_e} \quad (2.6)$$

where the ($\dot{}$) notation indicates rate of change and

A_p = piston area

C_{tp} = total leakage coefficient of piston

V_t = total volume of piston chamber and supply hose

β_e = effective fluid bulk modulus

The total leakage coefficient is given by:

$$C_{tp} = C_{ip} + 0.5C_{ep}$$

where

C_{ip} = internal leakage coefficient

C_{ep} = external leakage coefficient

For the system under investigation in this study, the external leakage has been determined to be negligible and $C_{tp} = C_{ip}$. With this simplification, and after Laplace transformation (with zero initial conditions), Eq. (2.6) becomes:

$$Q_L(s) = A_p s x_p(s) + C_{tp} P_L(s) + C_{cp} s P_L(s) \quad (2.7)$$

where the fluid capacitance is

$$C_{cp} = \frac{V_t}{4 \beta_e}$$

3. Load Dynamics

The load is modeled as a simple spring, mass, damper system. In the general form:

$$F_g = M_t \ddot{x}_p + B_p \dot{x}_p + K x_p + F_L \quad (2.8)$$

where

- F_g = force developed by piston
- M_t = total mass accelerated
- B_p = viscous load damping coefficient
- K = spring load constant
- F_L = arbitrary load force on piston

The force generated by the piston is determined by the piston area, the load pressure drop, and an efficiency to account for losses in the actuator. In this specific application there were no spring forces so $K=0$. The equation is now transformed into the Laplace domain with the the following result:

$$\eta_f A_p P_L(s) = M_t s^2 x_p(s) + B_p s x_p(s) + F_L \quad (2.9)$$

C. ANALOG SYSTEM MODEL

Now that the linear mathematical model for each component of the system has been developed, these equations can be combined to formulate the model for the hydraulic power element with servovalve current as an input. First Eq. (2.5) is equated to Eq. (2.7) to eliminate Q_L . This combined equation is then rearranged to express P_L as a function of the input current and the piston velocity. The result is:

$$P_L(s) = \frac{(K_{qi} I - A_p s x_p(s)) \left(\frac{1}{K_{ci} + C_{ip}} \right)}{\left(\frac{C_{cp}}{K_{ci} + C_{ip}} s + 1 \right)} \quad (2.10)$$

After rearrangement, Eq. (2.9) may be written:

$$s x_p(s) = \dot{x}_p(s) = \frac{(\eta_f A_p P_L(s) - F_L) \left(\frac{1}{B_p} \right)}{\left(\frac{M_t}{B_p} s + 1 \right)} \quad (2.11)$$

Equations (2.10) and (2.11) suggest the definition of two time constants, as follows:

$$T_1 = \frac{C_{cp}}{K_{ce}} \qquad T_2 = \frac{M_t}{B_p}$$

where $K_{ce} = K_{ci} + C_{ip}$ (effective leakage coefficient). The resulting block diagram is shown in Figure (2.4).

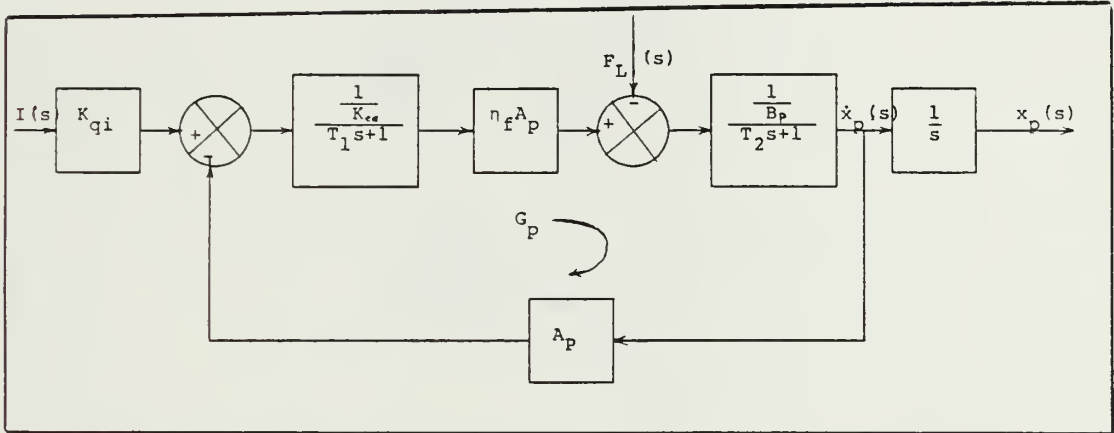

Figure 2.4 Analog System Block Diagram.

D. ANALYSIS OF THE SYSTEM

From preliminary lab observations the closed-loop analog system exhibits first order response behavior at low frequencies. It is clear from Fig. (2.4) that the hydraulic power element is third order. In an effort to understand this apparent contradiction further analytic analysis of the system is necessary. The results will serve as a benchmark for the computer simulation and system experimentation. Of prime interest are the system time constants and break frequencies.

First some block diagram reduction is useful. Under no-load ($F_L = 0$), the piston velocity may be represented by the following transfer function:

$$G_p(s) = \frac{s x_p(s)}{K_{qi} I} = \frac{\frac{\eta_f A_p}{B_p K_{ce}}}{(T_1 s + 1)(T_2 s + 1) + \frac{\eta_f A_p}{B_p K_{ce}}} \quad (2.12)$$

With some further simplification Eq. (2.12) may be rewritten:

$$G_p(s) = \frac{K_p}{\frac{s^2}{\omega_h^2} + \frac{2\zeta_h}{\omega_h} s + 1} \quad (2.13)$$

where:

$$K_p = \frac{\frac{\eta_f A_p}{B_p K_{ce}}}{1 + \frac{\eta_f A_p^2}{B_p K_{ce}}}$$

$$\omega_h^2 = \frac{1 + \frac{\eta_f A_p}{B_p K_{ce}}}{T_1 T_2}$$

$$\frac{2\zeta_h}{\omega_h} = \frac{T_1 + T_2}{1 + \frac{\eta_f A_p}{B_p K_{ce}}}$$

Recall K_{ce} incorporates the piston internal leakage (C_{ip}) and the modified null flow pressure coefficient (K_{ci}). It is known from experimentation and observation of the system that C_{ip} is on the order of 10^{-2} in³/sec-psi. What is necessary is to estimate the range of values over which K_{ci} will vary. Referring to Eq. (2.4), the maximum value of K_{ci} will occur when I is 200 mA and the valve is fully open. Putting in the values for this application ($P_s = 800$ psi, $P_{LO} = 0$) we obtain a value of 0.012 in³/sec-psi. A lower bound must now be found. According to the servovalve manufacturer the maximum quiescent flow at the null valve position is 0.35 gpm at 3000 psi. The system used for experimentation was run at 800 psi so one would expect that using the 3000 psi quiescent flow figure would give a conservative estimate of the lower bound. Using this figure for the lower bound the overall range of values for K_{ci}

is from 5.0×10^{-4} in³/lb-psi to 1.2×10^{-2} in³/lb-psi. In response to step inputs, the valve is fully open for a majority of the time so that a value of 1.4×10^{-3} in³/lb-psi has been selected for K_{ce} under these conditions.

Noting that K_{ce} and B_p are very small so that division by their product is a number which is very much greater than 1, the following simplifications to the constants of Eq. (2.13) are made:

$$K_p = \frac{1}{A_p}$$

$$\omega_h^2 = \frac{\eta_f A_p^2}{B_p K_{ce} T_1 T_2}$$

$$\frac{2\tau_h}{\omega_h} = \frac{T_1 + T_2}{\frac{\eta_f A_p^2}{B_p K_{ce}}}$$

The final block diagram of the closed-loop system is shown in Fig. (2.5), with G_A denoting the power amplifier transfer function (assumed to be a simple gain in this analysis).

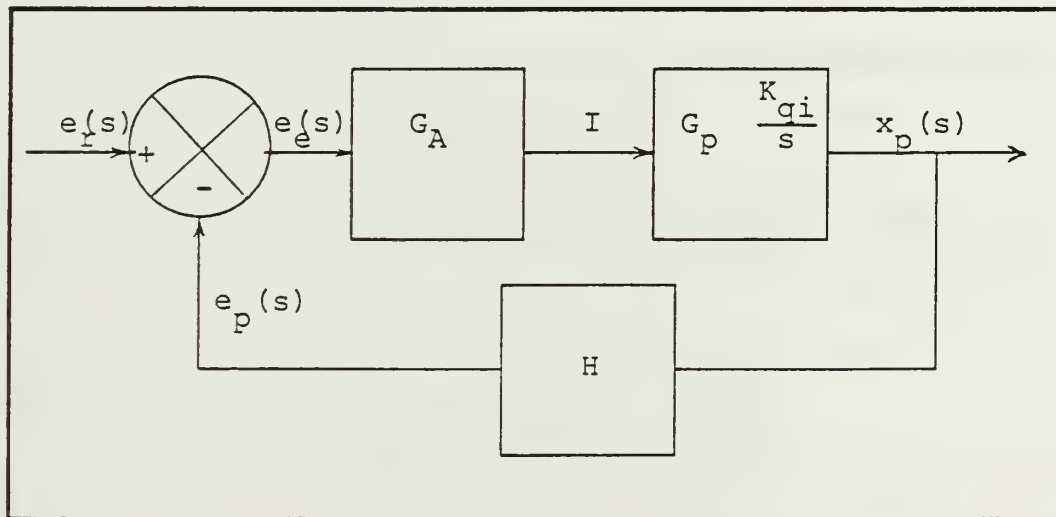

Figure 2.5 Closed Loop Analog System Block Diagram.

From this block diagram the overall transfer function is given as:

$$\frac{x_p(s)}{e_r(s)} = \frac{G_A(s)G_p(s)\frac{K_{qi}}{s}}{1 + H(s)G_A(s)G_p(s)\frac{K_{qi}}{s}} \quad (2.14)$$

When doing laboratory experiments the output (x_p) is compared to the input (e_r) in its feedback form e_p . Noting that $e_p(s) = H(s)x_p(s)$ and making the substitution for the plant transfer function the closed-loop transfer function becomes:

$$\frac{e_p(s)}{e_r(s)} = \frac{K}{s\left(\frac{s^2}{\omega_h^2} + \frac{2\zeta_h}{\omega_h}s + 1\right) + K} \quad (2.15)$$

where

$$K = G_A(s)K_p H(s)K_{qi}$$

In order to make an estimate of the break frequencies of the closed loop system some work with the characteristic equation is required. The characteristic function of Eq. (2.15) may be approximated as:

$$(s+K) [s + (2\zeta_h\omega_h - K)s + \omega_h]$$

under the condition that

$$2\zeta_h\omega_h - K \approx 0$$

This condition is satisfied in the present case and Eq. (2.15) may therefore be approximated as:

$$\frac{e_p(s)}{e_r(s)} = \frac{K\omega_h}{(s+K)(s^2 + \omega_h^2)} \quad (2.16)$$

The values for K and ω_h are 30 sec^{-1} and 261 sec^{-1} respectively (see Appendix A for constant values used to obtain these results). This yields a break frequency and hydraulic natural frequency of about 4.8 Hz and 41.6 Hz, respectively.

The conclusion to be drawn from this analysis is that the analog closed loop system acts like a first order system for low frequencies and a third order system with minimal damping at the higher frequencies. The hydraulic power element has very low damping which would make it unstable were it not for the integrating effects of the $(s + K)$ term in the characteristic equation.

E. FREQUENCY RESPONSE TEST

To verify the analytic results of the previous section, frequency response tests were conducted. The results are shown in Fig. (2.6a and 2.6b). From these figures two break frequencies are observed within the range of measurable system output, one at 2.7 Hz and one at 13.8 Hz. The second break frequency lies near the value estimated for the servovalve, which heretofore has been modeled as a simple gain.

Although the first break frequency of 2.7 Hz. is less than the predicted value of 4.8, this can be explained, at-least partially, by the uncertainty in the values leading to this estimate. In addition, the amplitude of the input sine wave in these tests caused the valve to be actuated over 43 % of its range of motion to either side of null. Such large excursions may be outside of the region where the valve flow linearization is valid, with the result that the amplitude plot is attenuated below the predicted linear response. In any case, the predicted dominance of the first break frequency is verified by the tests.

F. MODEL VALIDATION

Once a thorough theoretical understanding of the analog system was achieved a DSL simulation was written using Fig. (2.4) and Fig. (2.5) as guides. The simulation code is given in Appendix A. Figure (2.7) shows a comparison of experimentally obtained data and the model for a 0.195 in. step input. Agreement between predicted and actual performance is good at low step inputs however as the size of the step increases the model prediction becomes less accurate. Figure (2.8) shows a 1.785 in. step input response. Step response comparisons for steps between these values are given in Appendix B.

The most likely explanation for the degradation of model performance as the step size increases has to do with the valve linearization. Since this linearization was done around the null valve position one would expect more model prediction error with increasing step size. This is because as the step size is increased large excursions of the valve are required. Eventually the step size becomes so large that the valve goes to the

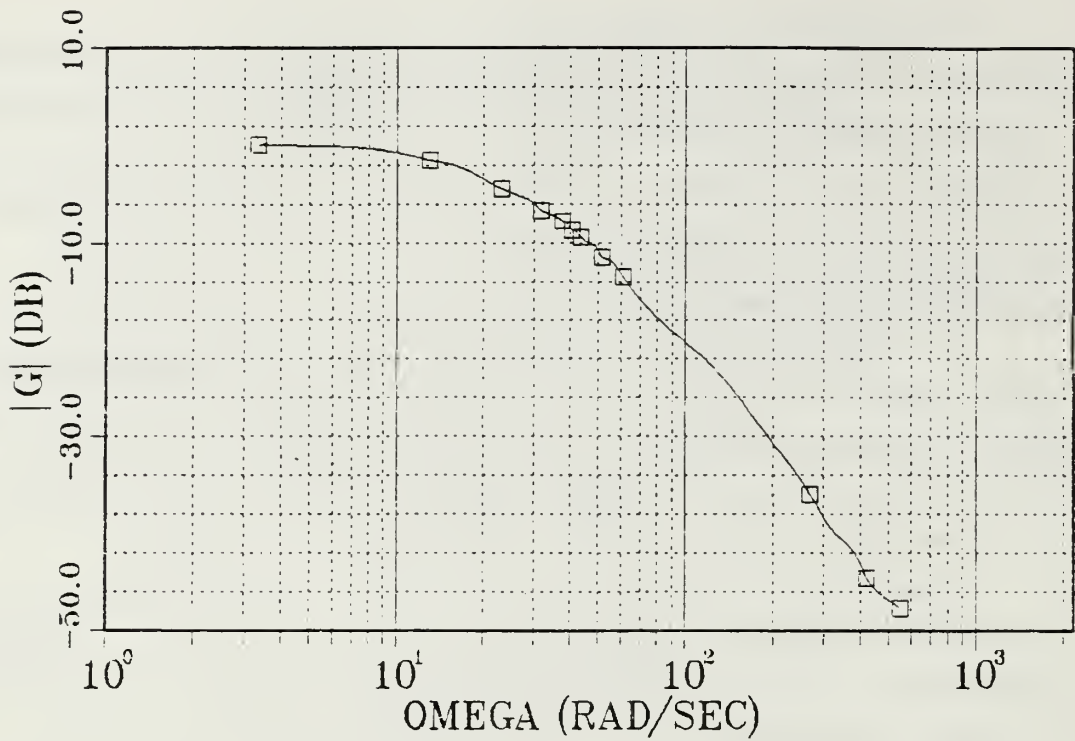

Figure 2.6a Closed Loop Frequency Response (Amplitude).

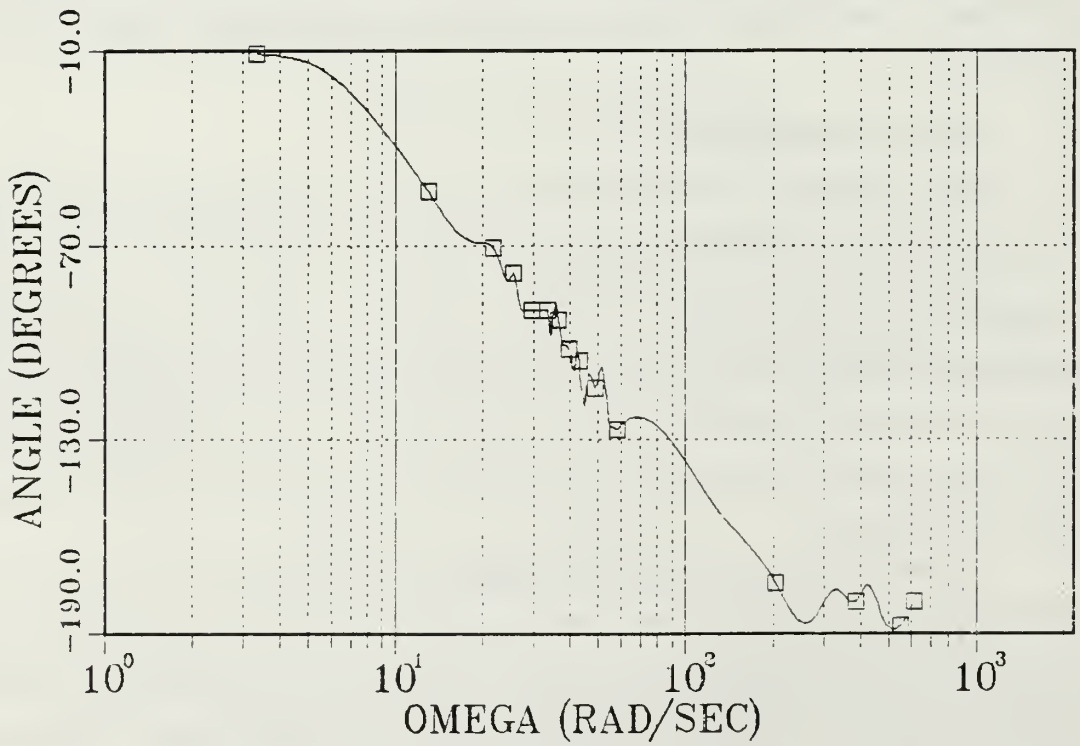

Figure 2.6b Closed Loop Frequency Response (Phase).

fully open position. Once this occurs increasing the step size further causes the valve to remain in this fully open position longer.

Still another explanation lies in the values of some of the constants used. The model is sensitive to changes in the load damping constant (B_p) which was obtained empirically. The model also shows sensitivity to the value of the modified null flow coefficient (K_{ci}). Both of these constants were refined from initial estimates to obtain the model performance shown in Fig. (2.7) and Fig. (2.8). Similar performance may possibly be obtained by the variation of the actuator efficiency (η_e) and the value for the effective bulk modulus (β_e) which are also empirically based.

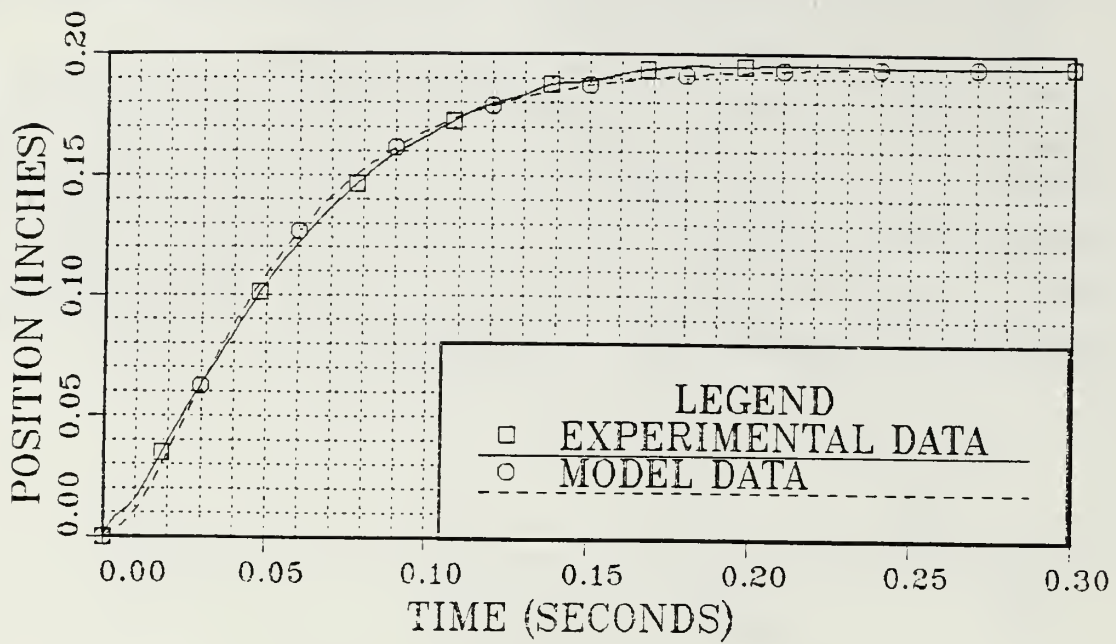

Figure 2.7 Analog System Step Response (0.195 in.).

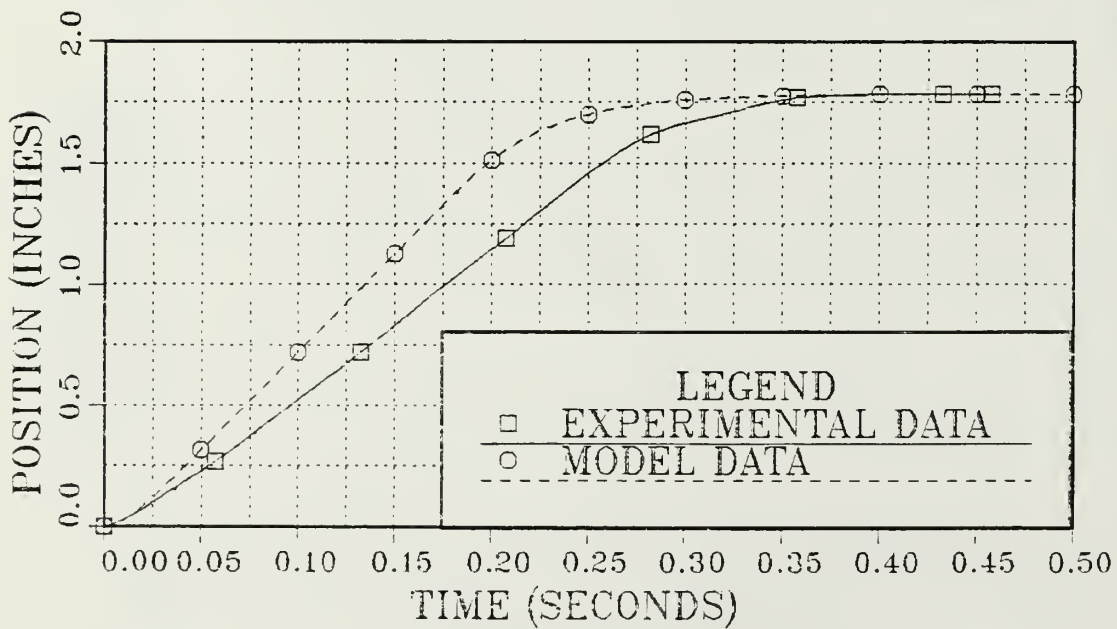

Figure 2.8 Analog Step Step Response (1.785 in.).

III. DIGITAL SYSTEM

A. DESCRIPTION OF THE SYSTEM

The digital system includes all the components of the analog system plus the following Hewlett-Packard computer and interface equipment which together comprise the microcomputer control system.

- HP 85B computer
- HP 82901M twin flexible disc drive
- HP 7470A plotter
- HP 6942A multiprogrammer with:
 - 2 A/D converter cards
 - 1 D/A converter card
 - 1 high speed memory card
 - 1 memory expansion card
 - 1 timer/pacer card

Figure (3.1) shows the complete digital system. Where previously the reference signal was fed to the power stage input (terminal 4) on the servoamplifier the error signal from the digital controller is now applied. The feedback signal is fed to the digital controller so that the differencing operation is shifted from the servoamplifier to the microcomputer controller.

The operation of the system under study begins with the operator entering a desired position in inches at the microcomputer keyboard. At this point the computer algorithm (see Appendix C) samples the feedback signal to determine the load position. This information is passed through the controller portion of the algorithm and an error signal is generated and sent to the servoamplifier. The generation of the error signal continues until the load reaches the desired position. The algorithm includes a position checking routine which maintains the commanded position until a new value is entered at the keyboard.

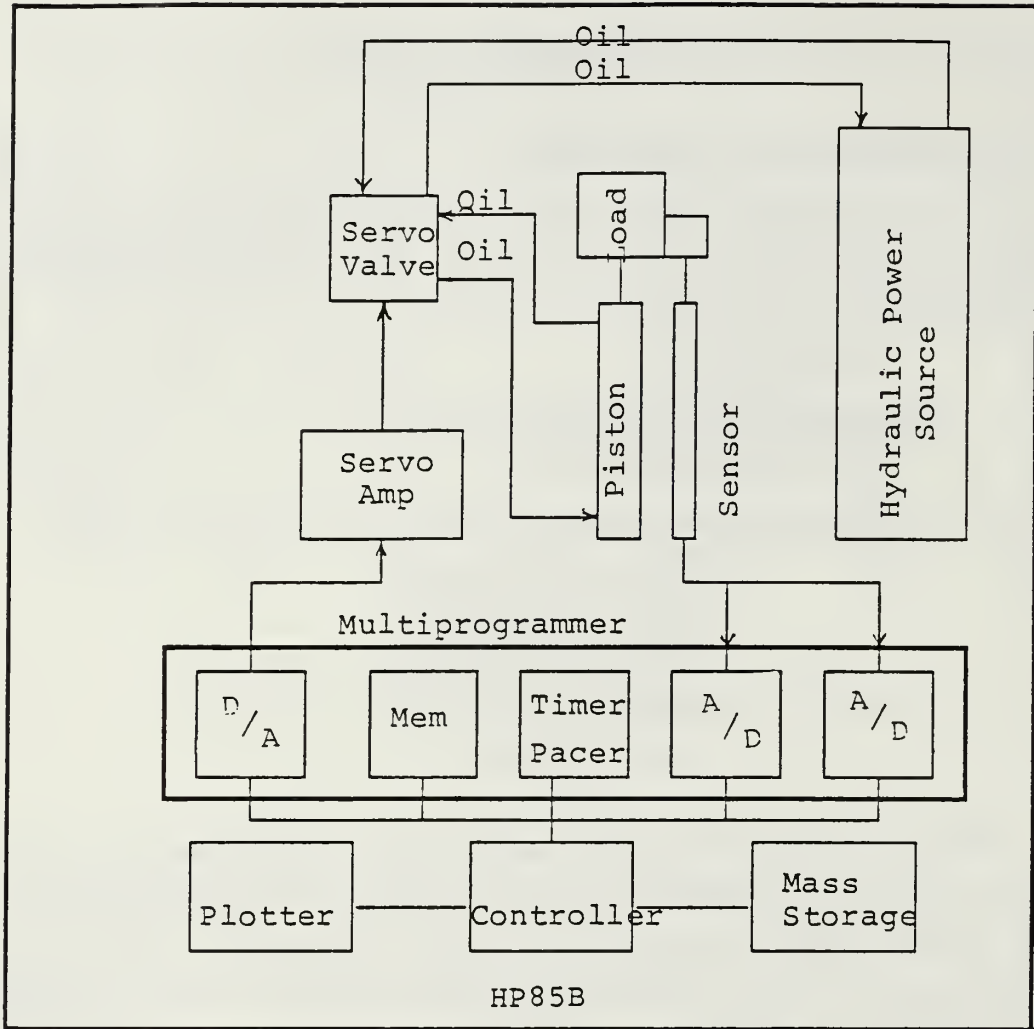

Figure 3.1 System with Digital Controller.

B. DIGITAL COMPONENT EQUATIONS

1. Application of the Analog Component Equations

The analog component equations developed in chapter two are applicable to the digital system with digital control. They collectively will comprise the plant model which the microcomputer controls.

2. Computer System Dynamics

To model the computer dynamics a digital or discrete time model is necessary. Areas important for consideration in the construction of this model are: understanding the meaning of sampling rate, modeling the effects of sampling, and modeling the type

of plant control used. The sampling rate is not merely the time the analog-to-digital (A/D) and digital-to-analog (D/A) converters take to process signals. It must also include the time taken for the controller algorithm to process the input signals and generate an output signal. Thus the sampling period "T" is the total time which elapses between sampling of the feedback signal and transmittal of the error signal.

The effects of sampling are more clearly understood if first an example of how the system operates is presented. Let us say the load is at the center (null) position. At time $t=0$ a 1-in. position is requested at the keyboard. This causes the position feedback input to be sampled, inverted and summed with the requested position. Next the summed signal is passed through the controller algorithm and the resulting error signal transmitted to the servoamplifier. The error signal remains at this level until one sampling period ($1T$) has elapsed and it is updated. For example, if the sampling period were 100 ms and the initial error signal 10 volts, 10 volts would be continuously sent to the servoamplifier for a period of 100 ms. Then presumably the error signal would be updated to say 5 volts and 5 volts would be continuously sent to the servoamplifier for the next 100 ms etc.

In the analog system a smooth continuous error signal resulted from the summation of the reference and position feedback signals. In the microcomputer control system the error signal produced is a continuous series of steps. A signal of this form is said to be "quantized." The steps have a duration of one sample period. If the sample period is too long then the error signal is not changing fast enough to control the system. This will cause the system to be unstable. To prevent this, a rule of thumb adapted from Shannon's Sampling Theorem is used. The rule suggests that the sampling frequency be ten times as large as the highest break frequency of the system.

One of the ways to model the behavior of the microcomputer control system is shown in Fig. (3.2). While there are several types of holding devices the zero-order hold is best suited for this application. The zero-order hold takes in a digital value and outputs that value continuously until one time period has passed and it receives an updated digital value. The input to the zero-order hold is $e_z^*(t)$ {where the (*) denotes a digital or discrete time signal} which is the error signal generated by passing the summed signal $e_z^{*'}(t)$ through the controller G_c . The output from the zero-order hold is $e_z(kT)$ the quantized error signal. The combination of the switch and the zero-order hold represent the D/A converter.

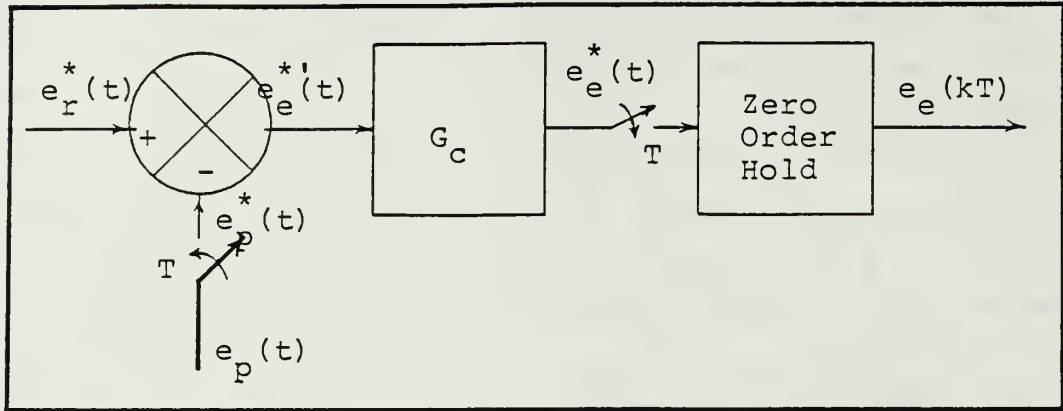

Figure 3.2 Microcomputer Controller.

The plant controller G_c represents that part of the algorithm which contains the controller logic. This logic can take the form of a simple gain or be more complicated such as a proportional-integral-derivative controller. To model this a discrete time representation of G_c must be obtained. To help illustrate the process an example is presented. The approach begins by obtaining the Laplace domain representation of the controller transfer function $\{G_c(s)\}$. Say the controller uses integral control action. This is represented in the Laplace domain as:

$$G_c(s) = \frac{e_e^*(s)}{e_e^{*'}(s)} = \frac{K_i}{s} \quad (3.1)$$

Next $G_c(s)$ must be transformed to the Z or discrete time domain by obtaining the Z-transform. This may be done by one of three methods: by transforming first to the time domain and then to the Z-domain (the rigorous approach), by an approximation method such as Euler's or backward difference, or by using tables. For this example a table was used to obtain the following:

$$G(z) = \frac{e_e^*(z)}{e_e^{*'}(z)} = \frac{K_i z}{z-1} \quad (3.2)$$

Dividing the top and bottom of Eq. (3.2) by z the following results:

$$G(z) = \frac{e_e^*(z)}{e_e^{*'}(z)} = \frac{K_i}{1-z^{-1}} \quad (3.3)$$

With some rearrangement Eq. (3.3) can be written:

$$e_e^*(z) = K_i e_e^{*'}(z) + e_e^*(z) z^{-1} \quad (3.4)$$

The inverse Z-transform is now taken for each term of Eq. (3.4) to obtain the discrete time model.

$$e_e^*(t) = K_i e_e^{*'}(t) + e_e^*(t-T) \quad (3.5)$$

The $e_e^*(t-T)$ term represents the value of $e_e^*(t)$ one time period backwards and is known as the first past value of $e_e^*(t)$. Had the $e_e^*(z)$ been multiplied by z^{-n} in Eq. (3.5) then this would have inversely transformed to $e_e^*(t-nT)$ which represents the value of $e_e^*(t)$ n time periods in the past.

Had Eq. (3.3) been more complex a more rigorous approach would have been employed. The equation would have been arranged in such a manner as to permit its representation as a geometric series or a combination of several geometric series. Then the remainder of the procedure would be followed as in the previous example with the complication that rather than a finite number of terms the number of terms (in Eq. (3.5) for example) would be infinite. A decision would have to be made as to how many terms to use to approximate the series. Usually only the first few terms are needed to yield sufficient accuracy for modeling.[5,6]

For this specific application a proportional controller is used so that $G_c = K_{pc}$. In this case it is not necessary to go through the various transformations since K_{pc} is merely a constant and remains so in the discrete time domain.

C. DIGITAL SYSTEM MODEL

The digital system model is a combination of the continuous time plant model developed in chapter two and the discrete time microcomputer controller model

explained in this chapter. The block diagram of the system model is shown in Fig. (3.3).

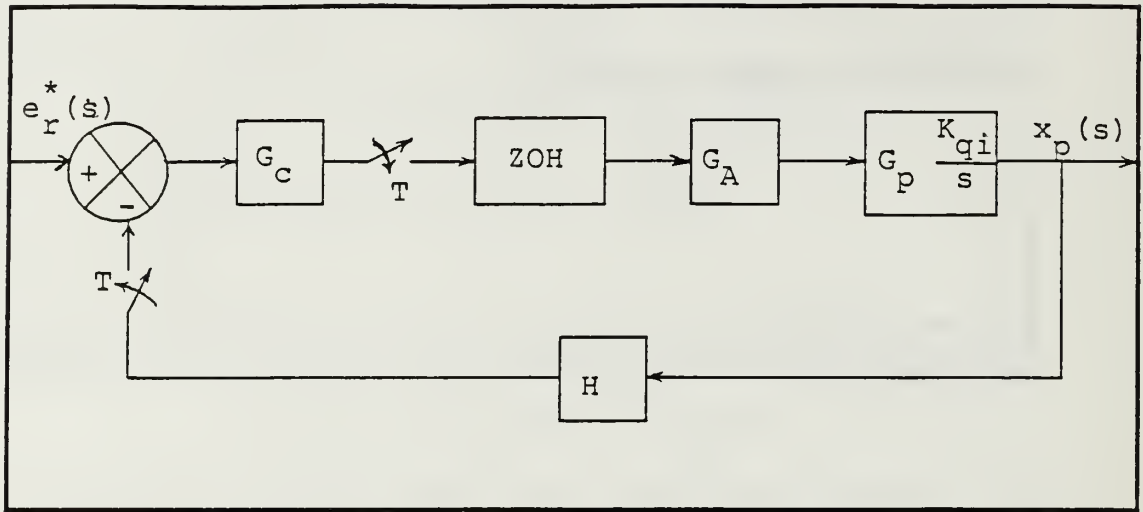

Figure 3.3 Digital System Model.

D. MODEL VALIDATION

Once confidence was gained in the validated analog simulation, coding was added to model the microcomputer control system. The biggest problem in obtaining an accurate simulation was predicting the value for T . A value of 0.35 sec was chosen based on timing the execution of the controller segment of the computer algorithm. Using this value and $K_{pc} = 1.0$ the simulation predicted a stable limit cycle response to any size step input. With $K_{pc} = 0.05$ the simulation predicted stable responses to various step inputs similar to those obtained from the analog system. At this point lab validation of these results was attempted.

The prediction of performance with $K_{pc} = 1.0$ was qualitatively correct. Stable limit cycle performance was observed regardless of the size of the step input. Next $K_{pc} = 0.05$ was attempted. At first it appeared that again the simulation had predicted the performance accurately. As time wore on however step responses became more and more oscillatory until once again, stable limit cycle response to any size step was observed. After some thought it became clear that what had varied over the time of the testing was the temperature of the oil. At the beginning of the tests the oil temperature was between 65°F and 75°F and stable step response behavior was

observed. As the oil heated, more and more oscillatory response was observed. Finally, around 85°F limit cycle response resulted. With these findings an operating temperature range of 100°F to 110°F was chosen for the remainder of lab testing. This is not to say that the failure of the microcomputer to control the plant is solely a result of variations in the oil temperature. In fact the analog system was stable regardless of the temperature and one would expect similar performance from the digital system.

The system performance with regard to oil temperature is interesting to note. By way of explanation of this behavior as the temperature goes up the oil viscosity decreases by a factor of about 10 in the range 65°F to 100°F. This in turn decreases the viscous damping on the already highly underdamped plant. This is true for both the analog and digital systems, however, and still does not explain the failure of the digital simulation to accurately predict system performance, given an adequate sampling frequency.

One of the critical parameters for stable digital control is the sample period. Using the rule of thumb suggested by Shannon's sampling theorem a sampling period of no more than 2.0×10^{-3} sec should be used. This value is obtained using the value of the hydraulic natural frequency as the highest plant break frequency. This insures an adequate sampling period but does not account for effects of changing the controller gain. Reducing the controller gain slows the response time of the entire system and thus a longer sampling period may be tolerated. To reflect this a slight variation of the rule of thumb is used. Rather than using ten times the highest break frequency, ten times the open loop bandwidth of the system frequency response is employed. The bandwidth is approximately K , the open loop gain. With $K_{pc} = 1.0$ a sample period of 25×10^{-3} sec was obtained. This means our controller is sampling too slowly to control the plant. With $K_{pc} = 0.05$ a sample period of 0.5 sec is obtained. This indicates that the digital controller using this gain should be able to control the plant. This serves to substantiate the predictions made by the simulation but does not help explain why the system exhibits limit cycle performance even with the lower controller gain.

Next investigated was the digital logic. It was felt that perhaps the DSL functions were not performing as expected. The response to a 3 in. step was requested and the values for the position (x_p), the current supplied to the servovalve (I), and the error signal values were observed. A portion of the data run is included in Appendix E. The data indicates that the digital logic included in the simulation is working correctly and is not the source of prediction error.

The reason for the failure of the digital simulation to predict the system performance remains unfound. It is felt by the researcher that the logic used in the model is correct. Time constraints prevented the investigation of other possibilities. For instance, the system with digital control may be more sensitive to the non-linearities inherent in the plant. This would explain why the analog model gave accurate predictions while the digital simulation did not. Accurate simulation of these non-linearities may be required to improve the digital simulation prediction performance. Finally, as already discussed, several of the constants used were empirically obtained and may be effecting the performance of the digital model more adversely than the analog. It is only after confidence in these constants is obtained that this possibility can be ruled out. Therefore any future work should begin here.

IV. CONCLUSIONS AND RECOMMENDATIONS FOR FOLLOW ON WORK

A. CONCLUSIONS

Microcomputer control of hydraulically actuated systems is possible and offers many advantages over conventional analog control. Of extreme importance in digital control is the sample period. Selection of control hardware/software should not be undertaken without first understanding the plant. An estimate of the highest break frequency must be obtained to determine the necessary sampling period. Only after this is determined can one properly select hardware/software for the plant controller. But proper selection of the sampling period is not enough. Non-linearities in the plant may cause instabilities in the digitally controlled system. It is theorized by the researcher that further reductions in the sample period will overcome this problem for the system studied. It was not possible to verify this, but the fact that the analog system was stable certainly indicates that somewhere between a sample period of 0.35 sec and 0.0 sec stability is achieved.

B. RECOMMENDATIONS FOR FOLLOW ON WORK

1. Valve Linearization

One of the greatest weaknesses of the analog and digital models lie with the linearization of the valve flow equation. Much of the time the valve is operating at the fully open position rather than null position. Because a choice of one position had to be made for this thesis research the null position was most logical for reasons already mentioned. Certainly using a number of linearizations over the full range of valve spool movement would yield more accurate simulation results. As the valve transitions through its range of positions different (more accurate) linearization constants would be applied. It is theorized that this approach will improve the performance of both models.

2. Plant Characterization

For the purposes of this initial research a sine wave generator was used to generate a low amplitude sine wave at several different frequencies to characterize the plant. While this was adequate for this work more accuracy and the ability to filter out noise at higher frequencies are necessary to fully characterize the plant. Doing this

will help to further confirm the analytical theory presented and more accurately fix the empirically obtained constants. This work can be done with a spectrum analyzer.

3. Model Supply and Return Pressure Dynamics

In the existing model supply pressure was assumed to be constant and return pressure was assumed to be zero. Since there was no accumulator in the supply line of the system under study the supply pressure varied slightly with demand. Return pressure although low was not zero. Inclusion in the model of these effects may improve simulation accuracy.

4. State Space Modeling

In order to obtain a linear model of the system under study some simplifying assumptions were made. One of these assumptions was that the arbitrary load force on the piston (F_L) was zero. This may have been an oversimplification and may be the reason the digital simulation does not accurately predict system performance. F_L represents friction forces which are non-linear and vary with piston velocity and direction. A state space representation, where F_L is included as one of the state variables, may eliminate this problem and improve the digital model performance.

5. Influence of Temperature on System Performance

Stability dependence on temperature was observed during testing of the digital system. Although it is known that higher fluid temperatures decrease viscous damping and thus have an overall destabilizing effect on the system, other less-obvious temperature effects may also be important. The relative insensitivity to temperature under analog control is an important issue yet to be resolved.

6. Data Acquisition System

The present HP microcomputer system has the capacity to be used as a controller and data acquisition system. All hardware required is in place, but time did not permit the development of software to implement the data acquisition capabilities of the system. This would be useful for further studies of the hydraulic power element and for lab work performed to support graduate classes in advanced controls.

APPENDIX A

ANALOG SIMULATION CODE (DSL)

*
*
*
*
*
*
*
*
*
*
*

SIMULATION OF THE VALVE CONTROLLED PISTON
(VCP) SERVOMECHANISM
(LINEAR ANALOG CLOSED LOOP MODEL)

(BLOCK DIAGRAM CODING)

*****GLOSSARY*****

- | | | |
|---------|--|---|
| * | | * |
| * AP | = ACTUATOR EFFECTIVE AREA, IN**2 | * |
| * BETAE | = EFFECTIVE BULK MODULUS, PSI | * |
| * BP | = LOAD DAMPING CONSTANT, LB-SEC/IN. | * |
| * CCP | = EFFECTIVE CAPACITANCE OF TRAPPED FLUID, IN**3/PSI | * |
| * CIG | = INPUT GAIN, VOLTS/(INPUT IN IN) | * |
| * CIP | = ACTUATOR INTERNAL LEAKAGE COEFFICIENT, IN**3/SEC-PSI | * |
| * EMAX | = MAXIMUM VOLTAGE FOR FEEDBACK TRANSDUCER | * |
| * ERR | = ERROR SIGNAL JUST AFTER SUMMER, VOLTS | * |
| * ETAF | = ACTUATOR FORCE EFFICIENCY | * |
| * FL | = EXTERNAL APPLIED LOAD FORCE, LB | * |
| * G | = LOAD SPRING CONSTANT, LB/IN. | * |
| * GA | = SERVOAMPLIFIER OUTPUT GAIN, MA/VOLT | * |
| * H | = FEEDBACK GAIN, VOLTS/IN | * |
| * I | = LIMITED CURRENT SUPPLIED TO SERVOVALVE, MA | * |
| * IO | = LINEARIZATION MIDPOINT FOR VALVE CURRENT, MA | * |
| * IMAX | = SERVO VALVE MAXIMUM CURRENT, MA | * |
| * IREQ | = LIMITED CURRENT REQUIRED, MA | * |
| * KCE | = EFFECTIVE LEAKAGE COEFFICIENT, IN**3/SEC/PSI | * |
| * KCI | = VALVE FLOW PRESSURE COEFFICIENT, IN**3/SEC PSI | * |
| * KQI | = LINEARIZATION CONSTANT FOR VALVE FLOW GAIN, IN**3/SEC MA | * |
| * KV | = MODIFIED VALVE FLOW GAIN, IN**3/SEC-MA-SQRT(PSI) | * |
| * MT | = TOTAL ACCELERATED MASS, LBS*SEC**2/IN | * |
| * PL | = LIMITED LOAD PRESSURE DROP, PSI | * |
| * PLO | = LINEARIZATION MIDPOINT FOR LOAD PRESSURE DROP, PSI | * |
| * PL1 | = UNLIMITED LOAD PRESSURE DROP, PSI | * |
| * PLMAX | = MAXIMUM PERMISSIBLE LOAD PRESSURE DROP FOR MODEL, PSI | * |
| * PS | = SUPPLY PRESSURE, PSI | * |
| * Q | = FLOW FOLLOWING SUMMER, IN**3/SEC | * |
| * QL | = LIMITED VALVE FLOW, IN**3/SEC | * |

```

* QL1      = UNLIMITED VALVE FLOW, IN**3/SEC          *
* QLMAX    = MAXIMUM PERMISSIBLE VALVE FLOW FOR MODEL, IN**3/SEC  *
* VT       = TOTAL VOLUME UNDER PRESSURE, IN**3        *
* XP       = PISTON/LOAD POSITION, IN                  *
* XPD      = PISTON/LOAD SPEED, IN/SEC                *
* XR       = INPUT OR COMMANDED PISTON/LOAD POSITION, IN  *
*

```

```

*****
*
*
*
*

```

INITIAL

```

      I = 0.0
      XP = 0.0
      XPD = 0.0

```

*

```

CONST      AP = 1.46,          IO   = 0.0,          GA   = 110.0,    ...
           BP = 103.6,        KV   = 0.00352,        EMAX = 12.0,    ...
           CIG = 4.0,         MT   = 8.517E-02,      ETAF  = 1.0,    ...
           CIP = 8.1E-03,     PS   = 800.0,          IMAX  = 200.0,  ...
           FL  = 0.0,         PLO  = 0.0,          QLMAX = 9.95606, ...
           G   = 0.0,         VT   = 44.0,          PLMAX = 400.0,  ...
           H   = 4.0,         BETAE = 3.0E04,       KCI   = 6.0E-03

```

*

PARAM XR = 1.785

*

THIS PART OF THE CODE DEFINES SOME OF THE CONSTANTS

*

```

      KCE = KCI+CIP
      KQI = KV*(PS-PLO)**0.5
      CCP = VT/(4.0*BETAE)
      T1 = CCP/KCE
      T2 = (MT/BP)

```

*

DERIVATIVE

*

THIS PART OF THE CODE IS THE PLANT FROM THE ANALOG BLOCK DIAGRAM

*

```

      Q = I*KQI-XPD*AP
      Q2= Q/KCE
      PL= REALPL(0.0,T1,Q2)

```

*

```

      F = PL*ETAF*AP-FL
      F1= F/BP
      XPD = REALPL(0.0,T2,F1)
      XPD1= INTGRL(0.0,XPD)

```

```

        XP =LIMIT(-3.0,3.0,XP1)
*
*
DYNAMIC
*
*   THIS PART OF THE CODE REPRESENTS THE SUMMER AND THE AMPLIFIER GAIN
*
        ERR = ((XR*CIG)-(XP*H))
        IF (ERR.GT.1.8.OR.ERR.LT.-1.8) THEN
                I=200.0*ABS(ERR)/ERR
        ELSE
                I=ERR*GA
        ENDIF
*
*
CONTRL FINTIM = 0.50
SAVE 0.010, XP
PRINT 0.010, XP
END
GRAPH (DE=TEK618) TIME(UN='SEC'), XP(UN='IN')
LABEL LINEAR CLOSED LOOP ANALOG MODEL
END
STOP

```

APPENDIX B
ANALOG MODEL VALIDATION DATA

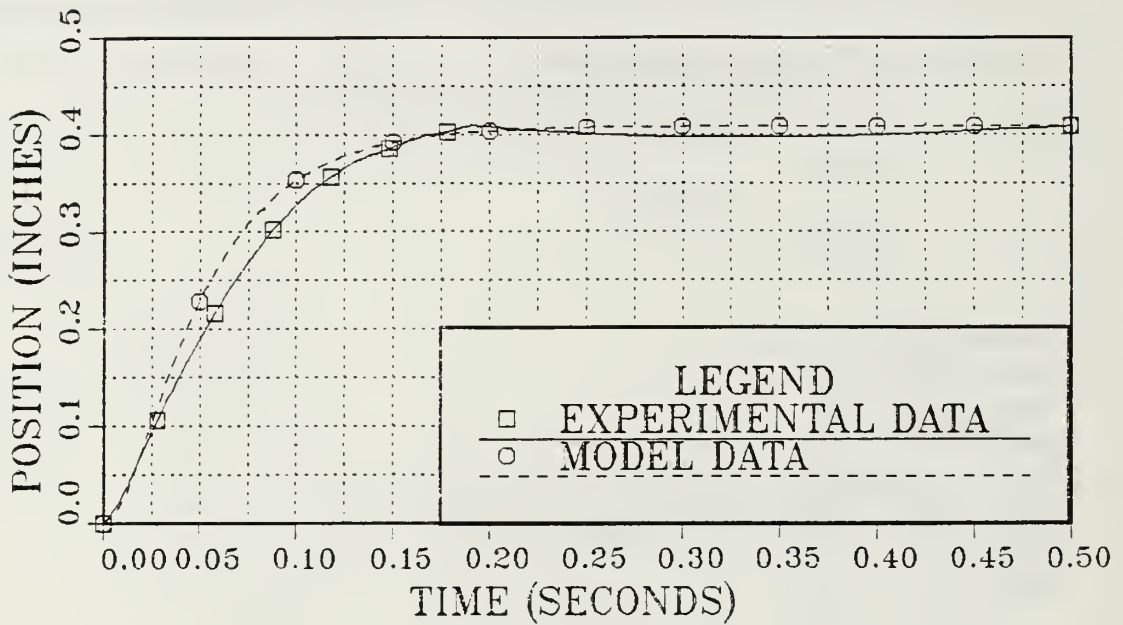

Figure B.1 Analog System Step Response (0.4088 in.).

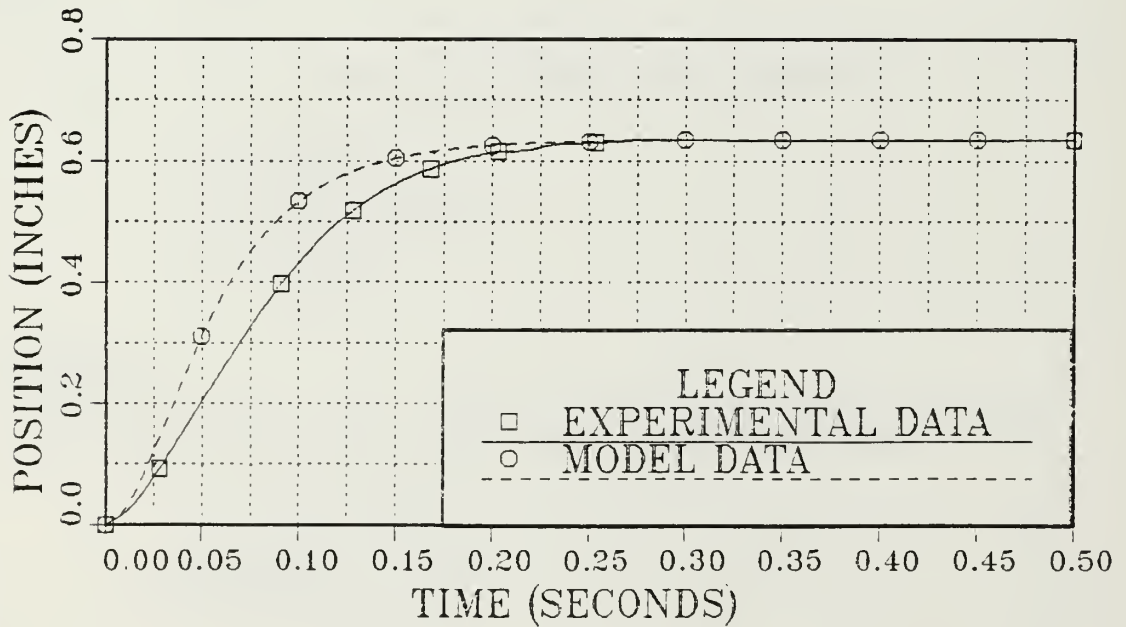

Figure B.2 Analog System Step Response (0.635 in.).

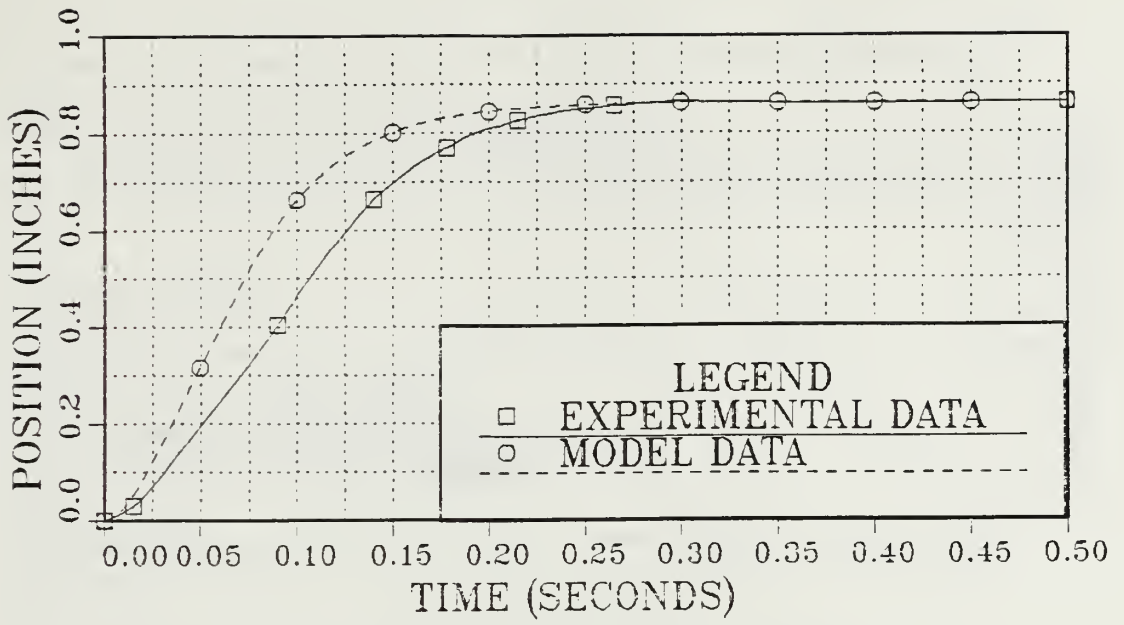

Figure B.3 Analog System Step Response (0.8625 in.).

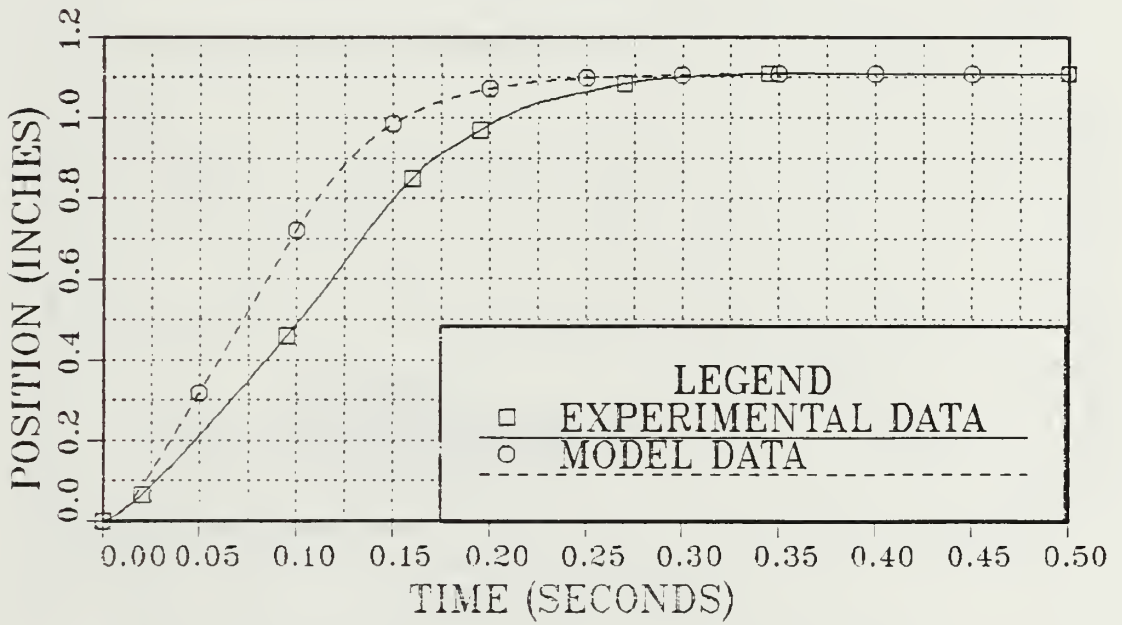

Figure B.4 Analog System Step Response (1.11 in.).

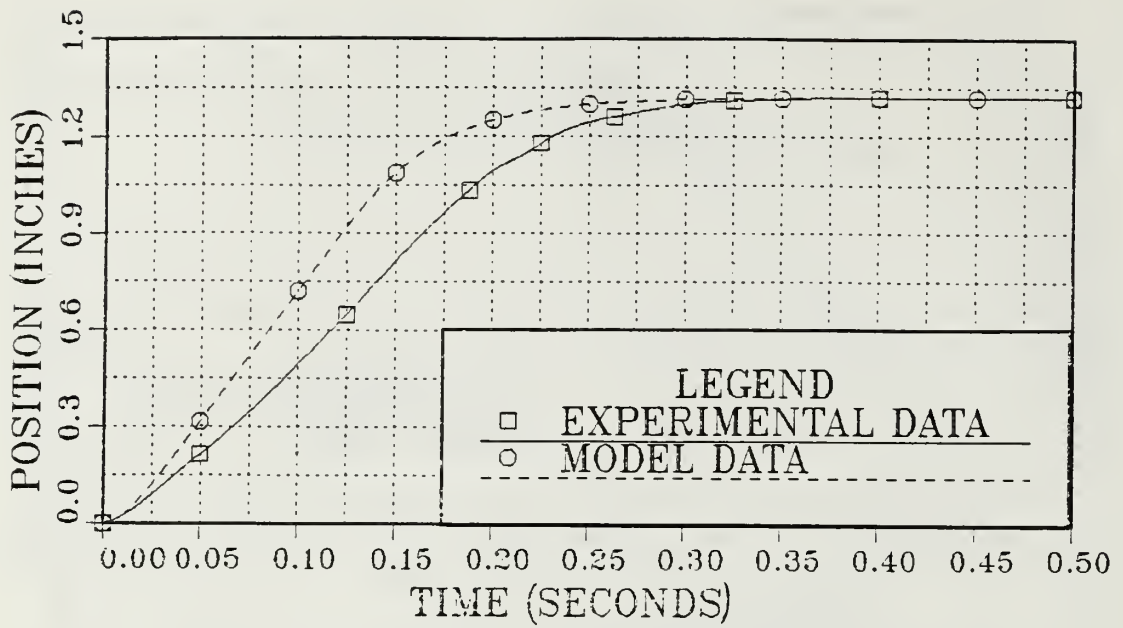

Figure B.5 Analog System Step Response (1.32 in.).

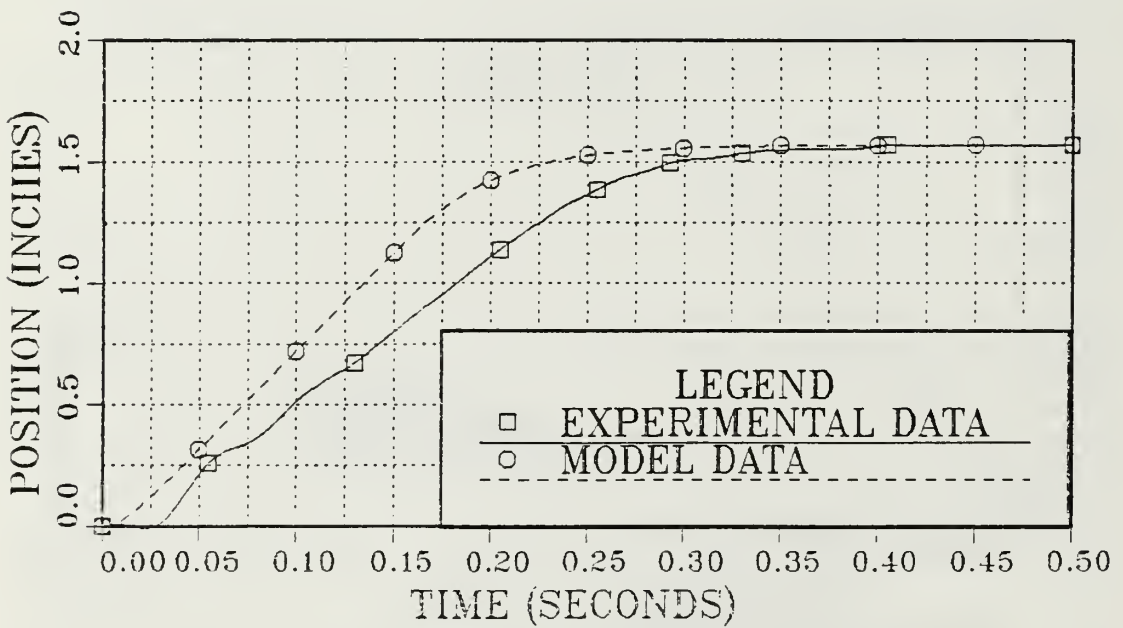

Figure B.6 Analog System Step Response (1.57 in.).

APPENDIX C
MICROCOMPUTER CONTROL SYSTEM ALGORITHM (BASIC)

```
10 REM CLOSLOOP
20 REM
30 REM THIS PROGRAM IS FOR
40 REM CLOSED LOOP POSITION
50 REM CONTROL OF A
60 REM HYDRAULICALLY ACTUATED
70 REM PISTON
80 REM K=KPC
90 REM
100 K=.05
110 SETTIME 0,0
120 ON KEY# 1,"INTERUPT" GOTO 130
130 DISP "WHAT IS DESIRED POSITION ?"
140 DISP
150 DISP "INPUT -3.0 TO 3.0 INCHES"
160 INPUT P
170 CLEAR
180 KEY LABEL
190 R=P*3.3333
200 OUTPUT 723 ;"IP 8T"
210 SEND 7 ; UNL MLA TALK 23 SCG 1
220 ENTER 7 ; F
230 E=(R-F)*K
240 S=SGN(E)
250 IF ABS(E)>10 THEN E=S*10
260 OUTPUT 723 ; "OP 3" ,E,"T"
270 IF ABS(E)>.125 THEN GOTO 200
280 OUTPUT 723 ;"IP 8T"
290 SEND 7 ; UNL MLA TALK 23 SCG 1
300 ENTER 7 ; F
310 IF ABS(R-F)>.125 THEN GOTO 230
320 IF TIME>120 THEN GOTO 340
330 GOTO 280
340 DISP
350 DISP "PROGRAM END"
360 END
```

APPENDIX D

DIGITAL SYSTEM SIMULATION CODE (DSL)

*
*
*
*
*
*
*
*
*
*
*
*

SIMULATION OF THE VALVE CONTROLLED PISTON
(VCP) SERVOMECHANISM
(LINEAR DIGITAL CLOSED LOOP MODEL)

(BLOCK DIAGRAM CODING)

*****GLOSSARY*****

*		*
* AP	= ACTUATOR EFFECTIVE AREA, IN**2	*
* BETAE	= EFFECTIVE BULK MODULUS, PSI	*
* BP	= LOAD DAMPING CONSTANT, LB-SEC/IN.	*
* CCP	= EFFECTIVE CAPACITANCE OF TRAPPED FLUID, IN**3/PSI	*
* CIG	= INPUT GAIN, VOLTS/(INPUT IN IN)	*
* CIP	= ACTUATOR INTERNAL LEAKAGE COEFFICIENT, IN**3/SEC-PSI	*
* EMAX	= MAXIMUM VOLTAGE FOR FEEDBACK TRANSDUCER	*
* ERR	= ERROR SIGNAL JUST AFTER SUMMER, VOLTS	*
* ETAF	= ACTUATOR FORCE EFFICIENCY	*
* FL	= EXTERNAL APPLIED LOAD FORCE, LB	*
* G	= LOAD SPRING CONSTANT, LB/IN.	*
* GA	= SERVOAMPLIFIER OUTPUT GAIN, MA/VOLT	*
* H	= FEEDBACK GAIN, VOLTS/IN	*
* I	= LIMITED CURRENT SUPPLIED TO SERVOVALVE, MA	*
* IO	= LINEARIZATION MIDPOINT FOR VALVE CURRENT, MA	*
* IMAX	= SERVO VALVE MAXIMUM CURRENT, MA	*
* IREQ	= LIMITED CURRENT REQUIRED, MA	*
* KCE	= EFFECTIVE LEAKAGE COEFFICIENT, IN**3/SEC/PSI	*
* KCI	= VALVE FLOW PRESSURE COEFFICIENT, IN**3/SEC PSI	*
* KPC	= CONTROLLER GAIN, (DIMENSIONLESS)	*
* KQI	= LINEARIZATION CONSTANT FOR VALVE FLOW GAIN, IN**3/SEC MA	*
* KV	= MODIFIED VALVE FLOW GAIN, IN**3/SEC-MA-SQRT(PSI)	*
* MT	= TOTAL ACCELERATED MASS, LBS*SEC**2/IN	*
* PL	= LIMITED LOAD PRESSURE DROP, PSI	*
* PLO	= LINEARIZATION MIDPOINT FOR LOAD PRESSURE DROP, PSI	*
* PL1	= UNLIMITED LOAD PRESSURE DROP, PSI	*
* PLMAX	= MAXIMUM PERMISSIBLE LOAD PRESSURE DROP FOR MODEL, PSI	*
* PS	= SUPPLY PRESSURE, PSI	*

```

* Q      = FLOW FOLLOWING SUMMER, IN**3/SEC          *
* QL     = LIMITED VALVE FLOW, IN**3/SEC          *
* QL1    = UNLIMITED VALVE FLOW, IN**3/SEC        *
* QLMAX  = MAXIMUM PERMISSIBLE VALVE FLOW FOR MODEL, IN**3/SEC *
* VT     = TOTAL VOLUME UNDER PRESSURE, IN**3     *
* XP     = PISTON/LOAD POSITION, IN                *
* XPD    = PISTON/LOAD SPEED, IN/SEC             *
* XR     = INPUT OR COMMANDED PISTON/LOAD POSITION, IN *
*                                               *
*****

```

```

*
*
*
*

```

INITIAL

```

      I = 0.0
      XP = 0.0
      XPD = 0.0

```

*

```

CONST      AP = 1.46,      IO = 0.0,      GA = 110.0,      ...
           BP = 103.6,    KV = 0.00352,    EMAX = 12.0,      ...
           CIG = 3.3333,  MT = 8.517E-02,  ETAF = 1.0,      ...
           CIP = 8.1E-03, PS = 800.0,      IMAX = 200.0,    ...
           FL = 0.0,     PLO = 0.0,      QLMAX = 9.95606, ...
           G = 0.0,     VT = 44.0,      PLMAX = 400.0,   ...
           H = 3.3333,   BETAE = 3.0E04,    KCI = 6.0E-03,   ...
           KPC = 0.05

```

*

PARAM XR = 3.00

*

* THIS PART OF THE CODE DEFINES SOME OF THE CONSTANTS

*

```

      KCE = KCI+CIP
      KQI = KV*(PS-PLO)**0.5
      CCP = VT/(4.0*BETAE)
      T1 = CCP/KCE
      T2 = (MT/BP)

```

*

DERIVATIVE

*

* THIS PART OF THE CODE IS THE PLANT FROM THE ANALOG BLOCK DIAGRAM

*

```

      Q = I*KQI-XPD*AP
      Q2= Q/KCE
      PL= REALPL(0.0,T1,Q2)

```

*

```

      F = PL*ETAF*AP-FL

```

```
F1= F/BP
XPD = REALPL(0.0,T2,F1)
XP1= INTGRL(0.0,XPD)
XP =LIMIT(0.0,6.00,XP1)
```

*

*

DYNAMIC

*

* THIS PART OF THE CODE REPRESENTS THE MICROCOMPUTER CONTROLLER AND
* AMPLIFIER GAIN

*

```
ERR = ((XR*CIG)-(XP*H))*KPC
IF (ERR.GT.1.8.OR.ERR.LT.-1.8) THEN
    IREQ=200.0*ABS(ERR)/ERR
ELSE
    IREQ=ERR*GA
ENDIF
Y= DELAY(0.350,0.350,IREQ)
X= IMPULS(0.0,0.350)
IREQQ= ZHOLD(X,Y)
I = LIMIT(-IMAX,IMAX,IREQQ)
```

*

*

*

CONTRL FINTIM =02.00, DELT=0.001

METHOD RKSFX

SAVE 0.010, XP,I,ERR

PRINT 0.010, XP,I,ERR

END

GRAPH (DE=TEK618) TIME(UN='SEC'), XP(UN='IN'), XPEX(UN='IN')

LABEL LINEAR CLOSED LOOP DIGITAL MODEL

END

STOP

APPENDIX E

DIGITAL LOGIC TEST DATA

***** RKSFX INTEGRATION METHOD USED *****
 *** DSL OUTPUT LISTING, GROUP 1

TIME	XP	I	ERR
0.00000E+00	0.00000E+00	0.00000E+00	0.49999
1.00000E-02	0.00000E+00	0.00000E+00	0.49999
2.00000E-02	0.00000E+00	0.00000E+00	0.49999
3.00000E-02	0.00000E+00	0.00000E+00	0.49999
4.00000E-02	0.00000E+00	0.00000E+00	0.49999
5.00000E-02	0.00000E+00	0.00000E+00	0.49999
6.00000E-02	0.00000E+00	0.00000E+00	0.49999
7.00000E-02	0.00000E+00	0.00000E+00	0.49999
8.00000E-02	0.00000E+00	0.00000E+00	0.49999
9.00000E-02	0.00000E+00	0.00000E+00	0.49999
1.00000E-01	0.00000E+00	0.00000E+00	0.49999
0.11000	0.00000E+00	0.00000E+00	0.49999
0.12000	0.00000E+00	0.00000E+00	0.49999
0.13000	0.00000E+00	0.00000E+00	0.49999
0.14000	0.00000E+00	0.00000E+00	0.49999
0.15000	0.00000E+00	0.00000E+00	0.49999
0.16000	0.00000E+00	0.00000E+00	0.49999
0.17000	0.00000E+00	0.00000E+00	0.49999
0.18000	0.00000E+00	0.00000E+00	0.49999
0.19000	0.00000E+00	0.00000E+00	0.49999
0.20000	0.00000E+00	0.00000E+00	0.49999
0.21000	0.00000E+00	0.00000E+00	0.49999
0.22000	0.00000E+00	0.00000E+00	0.49999
0.23000	0.00000E+00	0.00000E+00	0.49999
0.24000	0.00000E+00	0.00000E+00	0.49999
0.25000	0.00000E+00	0.00000E+00	0.49999
0.26000	0.00000E+00	0.00000E+00	0.49999
0.27000	0.00000E+00	0.00000E+00	0.49999
0.28000	0.00000E+00	0.00000E+00	0.49999
0.29000	0.00000E+00	0.00000E+00	0.49999
0.30000	0.00000E+00	0.00000E+00	0.49999
0.31000	0.00000E+00	0.00000E+00	0.49999
0.32000	0.00000E+00	0.00000E+00	0.49999
0.33000	0.00000E+00	0.00000E+00	0.49999
0.34000	0.00000E+00	0.00000E+00	0.49999
0.35000	0.00000E+00	54.999	0.49999
0.36000	7.01428E-03	54.999	0.49883

0.37000	2.35711E-02	54.999	0.49607
0.38000	4.37206E-02	54.999	0.49271
0.39000	6.51974E-02	54.999	0.48913
0.40000	8.71646E-02	54.999	0.48547
0.41000	0.10931	54.999	0.48178
0.42000	0.13153	54.999	0.47807
0.43000	0.15377	54.999	0.47437
0.44000	0.17602	54.999	0.47066
0.45000	0.19827	54.999	0.46695
0.46000	0.22052	54.999	0.46324
0.47000	0.24278	54.999	0.45953
0.48000	0.26503	54.999	0.45582
0.49000	0.28729	54.999	0.45211
0.50000	0.30954	54.999	0.44841
0.51000	0.33180	54.999	0.44470
0.52000	0.35405	54.999	0.44099
0.53000	0.37631	54.999	0.43728
0.54000	0.39856	54.999	0.43357
0.55000	0.42081	54.999	0.42986
0.56000	0.44307	54.999	0.42615
0.57000	0.46532	54.999	0.42244
0.58000	0.48758	54.999	0.41873
0.59000	0.50983	54.999	0.41502
0.60000	0.53209	54.999	0.41131
0.61000	0.55434	54.999	0.40761
0.62000	0.57660	54.999	0.40390
0.63000	0.59885	54.999	0.40019
0.64000	0.62111	54.999	0.39648
0.65000	0.64336	54.999	0.39277
0.66000	0.66561	54.999	0.38906
0.67000	0.68787	54.999	0.38535
0.68000	0.71012	54.999	0.38164
0.69000	0.73238	54.999	0.37793
0.70000	0.75463	54.999	0.37422
0.71000	0.77689	54.999	0.37052
0.72000	0.79914	54.999	0.36681
0.73000	0.82140	54.999	0.36310
0.74000	0.84365	54.999	0.35939
0.75000	0.86591	54.999	0.35568
0.76000	0.88816	54.999	0.35197
0.77000	0.91041	54.999	0.34826
0.78000	0.93267	54.999	0.34455
0.79000	0.95492	54.999	0.34084
0.80000	0.97718	54.999	0.33713
0.81000	0.99943	54.999	0.33342
0.82000	1.0217	54.999	0.32972
0.83000	1.0439	54.999	0.32601

0.84000	1.0662	54.999	0.32230
0.85000	1.0885	54.999	0.31859
0.86000	1.1107	54.999	0.31488
0.87000	1.1330	54.999	0.31117
0.88000	1.1552	54.999	0.30746
0.89000	1.1775	54.999	0.30375
0.90000	1.1997	54.999	0.30004
0.91000	1.2220	54.999	0.29633
0.92000	1.2442	54.999	0.29262
0.93000	1.2665	54.999	0.28892
0.94000	1.2887	54.999	0.28521
0.95000	1.3110	54.999	0.28150
0.96000	1.3333	54.999	0.27779
0.97000	1.3555	54.999	0.27408
0.98000	1.3778	54.999	0.27037
0.99000	1.4000	54.999	0.26666
1.0000	1.4223	54.999	0.26295
1.0100	1.4445	54.999	0.25924
1.0200	1.4668	54.999	0.25553
1.0300	1.4890	54.999	0.25183
1.0400	1.5113	54.999	0.24812
1.0500	1.5335	41.165	0.24441
1.0600	1.5540	41.165	0.24099
1.0700	1.5721	41.165	0.23798
1.0800	1.5893	41.165	0.23511
1.0900	1.6062	41.165	0.23230
1.1000	1.6229	41.165	0.22952
1.1100	1.6396	41.165	0.22674
1.1200	1.6562	41.165	0.22396
1.1300	1.6729	41.165	0.22118
1.1400	1.6896	41.165	0.21840
1.1500	1.7062	41.165	0.21563
1.1600	1.7229	41.165	0.21285
1.1700	1.7395	41.165	0.21008
1.1800	1.7562	41.165	0.20730
1.1900	1.7728	41.165	0.20452
1.2000	1.7895	41.165	0.20175
1.2100	1.8062	41.165	0.19897
1.2200	1.8228	41.165	0.19620
1.2300	1.8395	41.165	0.19342
1.2400	1.8561	41.165	0.19064
1.2500	1.8728	41.165	0.18787
1.2600	1.8894	41.165	0.18509
1.2700	1.9061	41.165	0.18232
1.2800	1.9227	41.165	0.17954
1.2900	1.9394	41.165	0.17676
1.3000	1.9561	41.165	0.17399

1.3100	1.9727	41.165	0.17121
1.3200	1.9894	41.165	0.16844
1.3300	2.0060	41.165	0.16566
1.3400	2.0227	41.165	0.16288
1.3500	2.0393	41.165	0.16011
1.3600	2.0560	41.165	0.15733
1.3700	2.0727	41.165	0.15456
1.3800	2.0893	41.165	0.15178
1.3900	2.1060	41.165	0.14900
1.4000	2.1226	26.885	0.14623
1.4100	2.1375	26.885	0.14375
1.4200	2.1498	26.885	0.14169
1.4300	2.1612	26.885	0.13979
1.4400	2.1723	26.885	0.13794
1.4500	2.1833	26.885	0.13612
1.4600	2.1942	26.885	0.13430
1.4700	2.2051	26.885	0.13249
1.4800	2.2160	26.885	0.13067
1.4900	2.2268	26.885	0.12886
1.5000	2.2377	26.885	0.12705
1.5100	2.2486	26.885	0.12523
1.5200	2.2595	26.885	0.12342
1.5300	2.2704	26.885	0.12161
1.5400	2.2812	26.885	0.11979
1.5500	2.2921	26.885	0.11798
1.5600	2.3030	26.885	0.11617
1.5700	2.3139	26.885	0.11435
1.5800	2.3247	26.885	0.11254
1.5900	2.3356	26.885	0.11073
1.6000	2.3465	26.885	0.10892
1.6100	2.3574	26.885	0.10710
1.6200	2.3683	26.885	0.10529
1.6300	2.3791	26.885	0.10348
1.6400	2.3900	26.885	0.10166
1.6500	2.4009	26.885	9.98502E-02
1.6600	2.4118	26.885	9.80371E-02
1.6700	2.4226	26.885	9.62241E-02
1.6800	2.4335	26.885	9.44110E-02
1.6900	2.4444	26.885	9.25979E-02
1.7000	2.4553	26.885	9.07849E-02
1.7100	2.4662	26.885	8.89718E-02
1.7200	2.4770	26.885	8.71588E-02
1.7300	2.4879	26.885	8.53457E-02
1.7400	2.4988	26.885	8.35327E-02
1.7500	2.5097	16.085	8.17196E-02
1.7600	2.5192	16.085	8.01361E-02
1.7700	2.5263	16.085	7.88649E-02

1.7800	2.5337	16.085	7.77112E-02
1.7900	2.5404	16.085	7.66011E-02
1.8000	2.5470	16.085	7.55069E-02
1.8100	2.5535	16.085	7.44187E-02
1.8200	2.5600	16.085	7.33327E-02
1.8300	2.5665	16.085	7.22475E-02
1.8400	2.5730	16.085	7.11625E-02
1.8500	2.5795	16.085	7.00777E-02
1.8600	2.5860	16.085	6.89930E-02
1.8700	2.5925	16.085	6.79082E-02
1.8800	2.5991	16.085	6.68235E-02
1.8900	2.6056	16.085	6.57387E-02
1.9000	2.6121	16.085	6.46540E-02
1.9100	2.6186	16.085	6.35693E-02
1.9200	2.6251	16.085	6.24845E-02
1.9300	2.6316	16.085	6.13998E-02
1.9400	2.6381	16.085	6.03150E-02
1.9500	2.6446	16.085	5.92303E-02
1.9600	2.6511	16.085	5.81456E-02
1.9700	2.6576	16.085	5.70608E-02
1.9800	2.6641	16.085	5.59761E-02
1.9900	2.6706	16.085	5.48913E-02
2.0000	2.6772	16.085	5.38066E-02

LIST OF REFERENCES

1. Finch, M.B., *Microcomputer Control of a Hydraulic Power Element*, M.E. Thesis, Naval Postgraduate School, CA, December 1986
2. Merritt, H.E., *Hydraulic Control Systems*, pp. 2-4, 84-87, 141, 148, John Wiley & Sons, Inc., 1967
3. Henke, R. W., *Why doesn't everyone use electronic controls?*, *Hydraulics & Pneumatics*, pp. 51-54, June 1985
4. Astrom, J. K. and Wittenmark B., *Computer Controlled Systems Theory and Design*, p. 5, Prentice-Hall Inc., 1984
5. Rosko, Joseph S., *Digital Simulation of Physical Systems*, p. 106, Addison-Wesley Publishing Co., 1972
6. Ogata, Katsuhiko *Modern Control Engineering*, pp. 625-631, Prentice-Hall Inc., 1970

INITIAL DISTRIBUTION LIST

		No. Copies
1.	Defense Technical Information Center Cameron Station Alexandria, VA 22304-6145	2
2.	Library, Code 0142 Naval Postgraduate School Monterey, CA 93943-5002	2
3.	Chairman, Code 69Hy Mechanical Engineering Department Naval Postgraduate School Monterey, CA 93943	1
4.	Professor R.H. Nunn, Code 69Nn Mechanical Engineering Department Naval Postgraduate School Monterey, CA 93943	2
5.	Commandant (G-ENE-4F) U.S. Coast Guard Headquarters 2100 2nd and V st. S.W. Washington, D.C. 20593	1
6.	Commandant (G-PTE-2) U.S. Coast Guard Headquarters 2100 2nd and V st. S.W. Washington, D.C. 20593	2
7.	Commanding Officer U.S.C.G.C. SPENCER (WMEC-905) c o C.G. Support Center 427 Commercial St. Boston, MA 02109 Attn: LT. Ian Grunther	5

DUDLEY KNOX LIBRARY
NAVAL POSTGRADUATE SCHOOL
MONTEREY, CALIFORNIA 93943-5002

Thesis
G8623 Grunther
c.1 Microcomputer control
of a hydraulically actua-
ted piston.

Thesis
G8623 Grunther
c.1 Microcomputer control
of a hydraulically actua-
ted piston.

thesG8623

Microcomputer control of a hydraulically



3 2768 000 73042 8

DUDLEY KNOX LIBRARY