

T 339

.H859

1883

Copy 1

PATENT SOLICITING
AND
U. S. COURT PRACTICE,

HOWSONS' PATENT OFFICES,
No. 119 SOUTH FOURTH STREET,
PHILADELPHIA.

THIRD EDITION.

LIBRARY OF CONGRESS.

Chap. Copyright No.

Shelf T 339

— H 859
UNITED STATES OF AMERICA.

1883



Patent Soliciting
AND
United States Court Practice,
AT
HOWSONS' PATENT OFFICES,
No. 119 South Fourth Street,
PHILADELPHIA.

THIRD EDITION.

FIRST EDITION.

Entered according to Act of Congress, in the year 1880,
BY HOWSON & SON,
in the Office of the Librarian of Congress, at Washington.

SECOND EDITION,

Copyright, 1881,
HOWSON & SONS.

THIRD EDITION.

Copyright, 1883,
HOWSON & SONS.

*Press of Times Printing House,
725 & 727 Chestnut St.,
Philadelphia.*



INTERIOR OF HOWSONS' PATENT OFFICES,
119 SOUTH FOURTH STREET,
PHILADELPHIA.

(FROM PHOTOGRAPH.)

Howson & Howson

HOWSONS' PATENT OFFICES

119 SOUTH FOURTH STREET,
PHILADELPHIA.

Branch Office,—915 F Street,
WASHINGTON, D. C.

PATENT SOLICITING AND UNITED STATES COURT PRACTICE

With Remarks concerning Specifications and Claims,
Drawings, Official Examination, Appeals, Reissues,
Searches and Reports, Court Practice,
Interferences, Foreign Patents, etc.

15.1
9392

THIRD EDITION.

✓
H. HOWSON,
Engineer and Solicitor of
PATENTS.

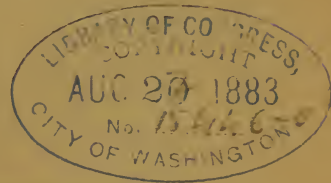

✓
C. HOWSON,
Att'y-at-Law, and Counsel in
PATENT CASES.

✓
H. HOWSON, Jr.,
Machinist and Draughtsman.

HUBERT HOWSON,
Attorney-at-Law.

Communications to be addressed to
HOWSON & SONS, PHILADELPHIA, PA.

[Faint handwritten notes at the bottom of the page]

FIRST EDITION.

Entered according to Act of Congress, in the year 1880,
BY HOWSON & SON,
in the Office of the Librarian of Congress, at Washington.

SECOND EDITION.

Copyright, 1881,
HOWSON & SONS.

THIRD EDITION.

Copyright, 1883,
HOWSON & SONS.

T 339
H 859
1883

CONTENTS.

	<i>Page</i>
PREFACE,	v-x
ORGANIZATION OF HOWSONS' PATENT OFFICES,	11, 12
FACILITIES FOR TRANSACTING BUSINESS,	13
Principal Offices, Philadelphia,	14, 15
Assistants and Clerks,	16
Office Hours,	17
Branch Office, Washington,	18
Library,	19-22
SOLICITING DEPARTMENT,	23
Introductory,	24-27
Preliminary Examinations,	28, 29
Models,	30, 31
Specifications and Claims,	32-35
Drawings,	36, 37
Prosecution of Applications,	38-41
Examiners,	42, 43
Time Required to Obtain Patents,	44
APPEALS,	45
To Examiners-in-Chief,	45
To Commissioner in Person,	46
Bills in Equity to Obtain Patents,	46
Interlocutory Appeals,	47, 48

	<i>Page</i>
REISSUES,	49-52
DISCLAIMERS,	53, 54
HOSPITAL CASES,	55, 56
REPORTS AS TO THE VALIDITY OF PATENTS,	57-60
PURCHASE, SALE, AND PUBLICATION OF PATENTS,	61, 62
CAVEATS,	63, 64
PATENTS FOR DESIGNS,	65
TRADEMARKS, LABELS, COPYRIGHTS,	66
Trademarks,	66, 67
Labels,	68
Copyrights,	68-71
SUMMARY OF CHARGES,	72, 73
LAW DEPARTMENT,	75
Introductory,	76-78
Our U. S. Court Practice,	78
Interferences,	79-86
FOREIGN DEPARTMENT,	87-102
PUBLICATIONS OF HOWSON & SON,	103-105
OFFICIAL CERTIFICATES,	106-110
REFERENCES,	111-122
SPECIMENS OF DRAWINGS,	

PREFACE.



THIS pamphlet is issued at a date when the twenty-sixth year of the existence of our house is nearly completed.

Since these offices were established, on a modest scale, in 1853, by the present head of the firm, a great change has taken place in the public estimation of and demand for patents and patent property. In 1853, the number of patents granted for new inventions was 846; in 1878, the number was 12,345. The increase has been continuous with the exception of slight fluctuations during the early years of the war and during the more recent financial depression.

It may not be out of place here to remark that this continued increase in the number of patents, has been proportionate to the increase of manufactures and the introduction of new industries.

Curiously enough, while a few of our law makers, blind to or ignoring the relation of patents to the progress of the useful arts, have endeavored to legislate against the interests of inventors, foreign countries are gradually adopting patent systems more or less like our own.

First, Canada adopted a new patent law as liberal as its former laws were oppressive; more recently, the German Empire, in spite of urgent opposition, established a system resembling our own in many particulars; Spain followed suit; the subject is being agitated in Switzerland and Russia, and even conservative England is likely to adopt more liberal laws.

Early in the history of this establishment, the increased activity among inventors which has accompanied a rapid development of the industrial arts in a country of vast resources, was foreseen, and preparations were made to meet the requirements of a growing business.

It was seen that a plentiful supply of books of reference relating to patents and manufactures must constitute the labor-saving machinery for the ready and accurate transaction of patent business; and a liberal expenditure of money has resulted in a library believed to be the most extensive private reference library, of its kind, in the country.

In 1868, the original offices were abandoned, and possession taken of the more commodious premises now occupied in Forrest Buildings, 119 South Fourth Street, and, at the same time, a branch office was opened in Washington.

Prior to 1869, the business of these offices had been restricted to the soliciting of United States and foreign patents; prosecuting contested cases before the Patent Office; and preparing for hearing, before the United States Courts, cases in which we retained counsel; but in that year our Mr. Charles Howson took charge of a special legal department of the office. This union, in the same establishment, of Patent Office with Court practice has been successfully carried out, and has been as advantageous to our clients as to ourselves.

It has been our experience that the most satisfactory, appreciative and successful clients are those who have the best knowledge of their true relation, as patentees, to

the public ; partly for this reason, and partly to save time in preliminary consultation, we published in 1872, mainly for the use of inventors, the "American Patent System," which has passed through three editions.

In 1877, Messrs. Porter & Coates published our "Brief Treatise on Patents," which has been highly commended by the authorities of the Patent Office, and has been used as a preliminary text-book in that Bureau.

In organizing these offices, our Mr. H. Howson has brought to bear that regard for system, division of labor, and ample appliances for the performance of routine duties, which he acquired during his early experiences as a civil and mechanical engineer, the main aim of the organization being to relieve the heads of the office and their leading assistants from such duties as demand little experience, so that their time may be entirely devoted to the mental work of an exacting profession.

We may be pardoned here for introducing the following quotation from Commissioner Spear's letter, which is published at the conclusion of this pamphlet.

"The high character of your work is no doubt aided in accuracy and promptness by the admirable organization of your office, the best I ever saw, and by your extensive and well-selected library."

One of the most noteworthy changes which has taken place during the last five or six years is the gradual acquisition, by inventors, of a knowledge of patent matters qualifying them to look more to their own interests than formerly.

From 1864 to 1868, applications for patents increased

so rapidly that the supply of experienced men to act the part of solicitors of patents, and advisers, was not equal to the demand; and consequently so many inexperienced, incompetent and illiterate men entered the profession, that in a short time they commenced to outbid each other for the patronage of inventors.

Cheaper and cheaper terms were offered, the no patent, no pay, system was resorted to, specifications were scribbled out by boys or dictated to copyists, no more thought being devoted to them than to the filling up of pension blanks, and patents with any kind of claims were accepted without regard to the interests of the patentees.

The consequence of all this was the flooding of the country with worthless patents, to the injury alike of inventors and the public, and the depreciation of patent property.

Such mischiefs could not exist in an intelligent community like ours without working their own remedy. Inventors and patentees began to think for themselves, and to inquire into the causes of their disappointments and losses. They have discovered that hours of intelligent labor at the hands of experienced men should be given to the duties which they had formerly intrusted to incompetent men, who gave to them neither time nor intelligence.

Inventors are gradually taking the advice of the Commissioner of Patents as published in the Official Gazette of August 27th, 1878.

“Let them exercise the same caution and judgment in selecting a patent solicitor, which a prudent man considers necessary in selecting any other professional man,

a physician or conveyancer, for instance, for performing duties which demand experience and exactitude."

While one object of this pamphlet is to direct the attention of inventors, and those interested in patents, to the facilities which this establishment affords for transacting both the legal and soliciting branches of our profession, and to obviate the necessity of time-consuming oral explanations of our mode of practice and system of charges, it has the further object of imparting general information on subjects with which all inventors should be familiar.

Almost every inventor to whom a patent has been granted, and whose residence is consequently published in the Official Gazette, receives a hatful of cheap circulars and pamphlets mailed by solicitors who adopt this mode of seeking clients.

Most of these advertising circulars and pamphlets are chiefly remarkable for the absence of information; indeed, they appear to be so prepared as to keep inventors in the dark, and envelop patent practice in a cloud of mystery.

This pamphlet is founded on the belief that there is nothing in the official routine of the Patent Office, nothing in the practice of soliciting patents, which an attorney who wants to deal fairly with his clients need conceal, and that candid information to inventors on patent practice, in all its phases, must be beneficial alike to the inventor and his attorney.

For this reason we have dwelt at considerable length on subjects to which we think the attention of inventors

should be more especially directed, such as specifications and claims, the prosecution of applications for patents, official examinations, reissues, interferences, reports as to validity of patents, etc.

The reader will find that in giving opinions freely and frankly on many subjects of importance, we have not forgotten to give reasons for these opinions, or to back them with quotations from reliable authorities.

In order to thoroughly explain our own mode of practice, we have found it necessary to compare it with that adopted by other men in our profession, and to state freely our objections to practices which we consider objectionable.

The reader must not suppose, however, that in passing our criticism of the practice of others, we arrogate to ourselves exceptional competency; on the contrary, there are gentlemen in the profession for whose attainments and integrity, we, in common with others, have the greatest regard.

In conclusion, we may express a hope, that while this little book serves all the purpose of a business pamphlet, the information which it contains may be of permanent service to the inventors into whose hands it may fall.

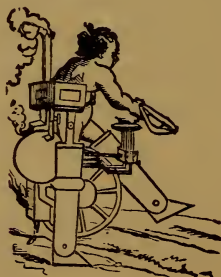

PREFACE TO SECOND EDITION.



SINCE the first edition of this book was published, two changes have been brought about, one being the enactment of a new Trademark law, the other, in which the interests of inventors are more directly involved, being the partial abolition of models in filing applications for patents.

These subjects will be referred to in full, under the heads of "Models" and "Trademarks."

We take this opportunity of addressing a few words of caution to those of our clients whose knowledge of patent matters is limited. For old inventors and patentees, the following remarks will be unnecessary, as they relate to subjects with which they have been made more or less familiar, in many instances by painful experiences.

The maintenance of judicious secrecy should be observed, not only in carrying out inventions and during the pendency of applications for patents, but especially after the applications have been allowed, and before the patents are actually granted; for an application may be arrested at any time prior to the absolute issue of the patent, and complications, in many cases fatal to the interests of inventors, have arisen through the failure of applicants to keep secret the facts relating to their pending and allowed cases.

This advice has been suggested by an organized effort which has been recently made to obtain a knowledge of allowed applications, apparently for speculative purposes.

Even after a patent has been procured, it is best for the patentee to be reticent about it, and especially concerning prospective remuneration, or profits actually derived from it.

Wherever there is a successful inventor, it will be found that his success has been in a great measure due to the observance of the same prudent reticence about his patent property, as he maintains concerning any other property, and to the wholesome avoidance of meddling intruders.

The losses of inventors, and the difficulties in which they become involved, are attributable in part to the reckless style of preparing and prosecuting applications, and in part to the advice of professional men who have had neither training nor practice in patent matters.

Older lawyers, of experience in general practice but not in patent litigation, are generally prudent enough to recommend clients to seek advice from those who are versed in that special practice; but it is well known to every patent practitioner of standing in the country, that the great amount of premature, wasteful and unnecessary patent litigation is largely due to young lawyers who have neither training in patent law or practice, nor the technical knowledge to enable them to undertake the duties they assume.

A general knowledge of law does not qualify a man to act as adviser to patentees. It must be accompanied

with an intimate familiarity with patent law, and with a technical and mechanical knowledge which should be applied in all cases before resort is had to patent litigation.

These remarks have been suggested by many recent cases which have come to the writer's knowledge, and in which the interests of patentees have been jeopardized by crude advice.

Inventors and patentees will best serve their own interests by treating men who intrude their advice, seek to pry into their patent property and its surroundings, and personally solicit employment, in the same manner as they would trespassers on any other property.

Competent men have neither the time nor inclination to thrust their unasked for services on inventors, or to go about begging for patronage.

THIRD EDITION.

The publication of a third edition of this pamphlet has been suggested mainly by one of the most important changes which has ever occurred in Patent Office and Court practice,—a change based on the decision of the United States Supreme Court relating to Reissued Patents in the case of *Miller vs. the Bridgeport Brass Co.*, and confirmed by subsequent decisions.

A perusal of the chapter on "Reissued Patents" will convince inventors that the fulfillment of their hopes more than ever depends upon the caution and good judgment based on experience, exercised in preparing and prosecuting their applications for patents.

Philadelphia, June 1, 1883.

CHARGES

WHEN THE INVENTIONS ARE OF SIMPLE CHARACTER.

INCLUDING GOVERNMENT FEES.

PRELIMINARY EXAMINATION :			
Payable in advance, but deducted from fees for applica- tion if made,			\$5.
FILING CAVEAT :			
Agency fee,	\$15	}	\$25.
Government fee,	10		
ORDINARY APPLICATION FOR PATENT :			
Agency fee,	\$40	}	\$55
First Government fee,	15		
Both paid prior to filing of application.			
Second Government fee,	\$20	}	\$75.
Payable after allowance of application but before grant of patent.			
REISSUE OF INVALID PATENTS :			
Agency fee,	\$50	}	\$80.
Government fee,	30		
APPLICATION FOR DESIGN PATENT :			
Agency fee,	\$20	}	\$30.
Government fee for patent of $3\frac{1}{2}$ years,	10		
“ “ “ 7 “	15		
“ “ “ 14 “	30		
REGISTRY OF TRADEMARK :			
Agency fee,	\$15	}	\$40.
Government fee,	25		
REGISTRY LABEL :			
Agency fee,	\$10	}	\$16.
Government fee,	6		

NOTE.—For extra fees in exceptional cases, see "Charges," page 71.

ORGANIZATION OF HOWSONS' PATENT OFFICES.

SOLICITING DEPARTMENT.

HENRY HOWSON,

Engineer, and Solicitor of Patents,
in charge of all cases before
the U. S. Patent Office.

ASSISTANTS.

H. SMITH,

Chief Clerk and Notary.

H. HOWSON, JR.,

Drawings.

LAW DEPARTMENT.

CHARLES HOWSON,

Attorney at Law and Counsel in
Patent Causes, in charge of
cases before the U. S.
Courts.

ASSISTANT.

HUBERT HOWSON,

Attorney at Law.

In the management of Patent suits, Henry Howson takes part, as advising counsel and consulting expert.

Each assistant has his clerk or clerks for attending to routine duties.

Although there are two departments in these offices, they are in that close alliance which is to the best interest of clients; the distribution of duties being such that while confusion is prevented, clients have the benefit of the experience and training of the heads of both departments.

In suits before the courts, for instance, the preliminary steps involving searches to determine the state of the art relating to inventions forming the subject of litigation, are within the province of an expert practically familiar with industrial arts and publications; hence these preliminary duties are performed mainly under the direction of Henry Howson, the subsequent conduct of the suit being in charge of Charles Howson.

On the other hand, all applications for patents or reissues involving the interests of contestants before the courts are reviewed by the head of the Law Department, as his management of the suit may depend upon the action of the Patent Office in such cases.

Again, in litigated cases before the Patent Office, the assistance of the heads of both departments and their assistants may be required.

The general soliciting of United States and foreign patents is in charge of Henry Howson, and assistants, as heretofore.



FACILITIES
FOR TRANSACTING BUSINESS.

PRINCIPAL OFFICES, 119 SOUTH 4TH ST., PHILADELPHIA.



INTERIOR OF HOWSONS' PATENT OFFICES.

A question naturally uppermost in the mind of a patentee or inventor, on perusing the business pamphlets of the professional men whose aid he seeks, is this: "What facilities have you for transacting the business entrusted to you?"

We will answer this question by a brief description of our offices and of our resources for performing our professional duties thoroughly, and as rapidly as thoroughness will allow.

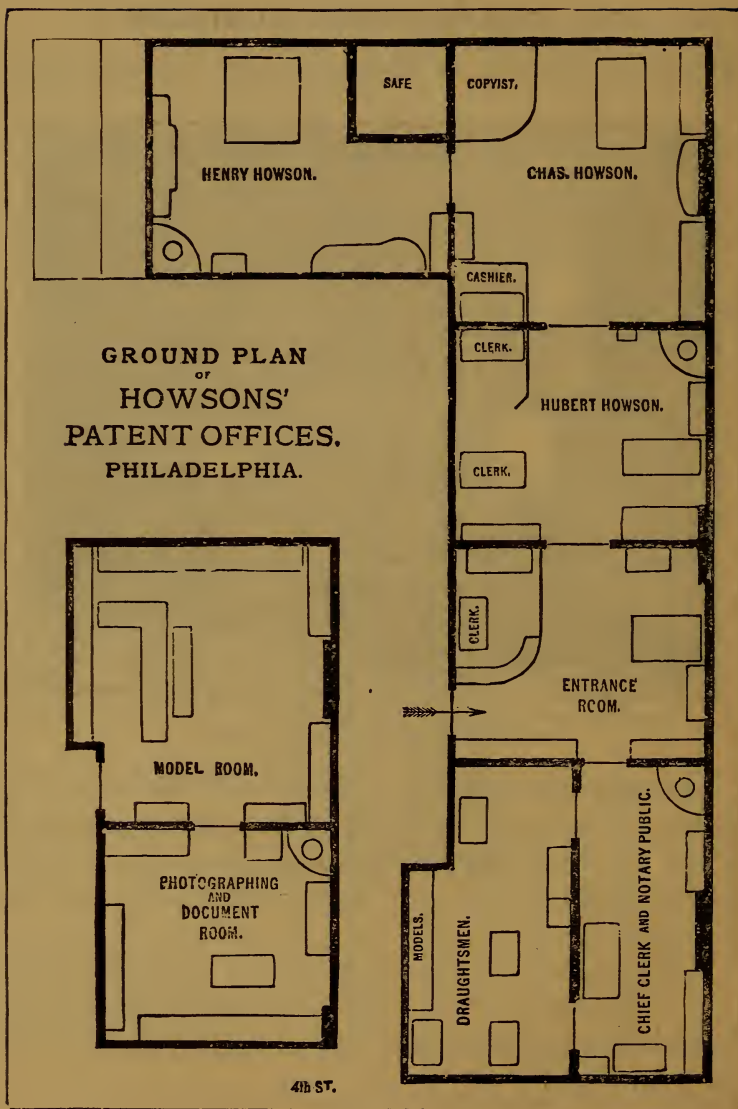



We occupy the second story of the right wing of Forrest Building, 119 South Fourth Street, in the heart of the city, where banks, manufacturers' agencies, large commercial houses, insurance and railroad offices, and the custom-house, are situated, and where, consequently, many of our clients, whether residing in or out of town, are frequently called by business. The offices are also near the United States Court, and within easy reach of the new Government buildings now in course of erection.

It will only be necessary to direct attention to the annexed ground plan of our offices to show how well adapted they are for the general supervision of employes, and for the maintenance of that privacy which the nature of the business so imperatively demands.

Independently of the six rooms in the second story occupied by our firm, two rooms in the upper story of the building are devoted to the storing of models and printed documents, and to the reproduction of drawings by photography, for which purpose new cameras and other apparatus have been recently purchased.

This arrangement of upper rooms prevents the encumbering of the offices below with accumulations of documents, drawings, models, etc., not in present use. There is also ample safe-room for papers and models relating to current business, and for valuable papers which cannot be replaced.

All papers are arranged in classes so as to be easily

found, and all the papers connected with any United States or foreign patent procured through these offices since 1859 can be obtained in a few minutes.

Ready communication of messages to all parts of the city is afforded by the wires of the American District Telegraph Company, and by the Edison Telephone with duplex wire arrangements, one wire communicating with the general office and thence with different manufactories, and a special wire connecting the office with the senior partner's private residence,—an arrangement which enables him to communicate readily with the office when engaged in intricate business at the house.

ASSISTANTS AND CLERKS.



A PECULIAR feature of this establishment is the employment, in responsible positions, only of those who have been trained in the offices from boyhood. It will scarcely be necessary to remark that by this plan the most reliable assistants are secured, and proper secrecy maintained.

The clerks of the establishment are not permitted, excepting on special occasions, to receive visits at the office on private business of their own, nor are they allowed at any time to transact private patent business, on their own account, or on that of any friends or acquaintances.

All drawings are made on the premises by expert draughtsmen who are skilled in the execution of perspective views.

OFFICE HOURS.

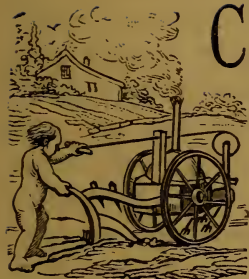

CLERKS are required to be in attendance from nine o'clock A. M. to half-past five P. M., with an intermission of half an hour.

Mr. H. Howson, has been compelled to restrict his office hours from nine o'clock A.M. to two P.M., in order that he may have reasonable time at his disposal for the preparation, revision, and amendment of specifications, and for other duties requiring privacy; he will, however, be ready to meet clients for consultations relating to important cases, at his residence in the evening, *with the understanding, however, that such visits must always be by special appointment.* The attendance of the senior partner at Washington is frequently demanded, but during his absence, which is always brief, any matters demanding his special personal attention will be promptly communicated to him.

As the senior clerk has charge of all papers connected with the soliciting department, he can answer promptly questions relating to pending applications.

The office hours of Mr. Charles Howson, in charge of the Law Department, are from ten A. M. to five P. M.

Visitors seeking general information relating to patents, will be cheerfully attended to, and can be furnished with a copy of any claim or other general information without charge, and can examine any of the official publications with which the office is plentifully furnished, a clerk being stationed in the entrance room to attend to the wants of such visitors.

OUR BRANCH OFFICE AT WASHINGTON.

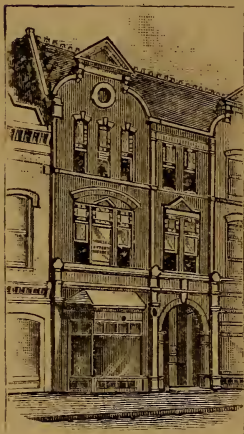

THIS office, which has recently been removed from 605 Seventh Street to the more commodious premises, No. 915 F Street, is under the direction of our Mr. Hubert Howson, who has acquired a thorough familiarity with the workings of the Patent Office during a two years' residence in Washington, and who visits that city weekly.

Visits of other members of our firm to the Patent Office are also frequently required for the prosecution of intricate applications, attending to contested cases, appeals, etc.

Our branch office is an essential part of the principal offices in this city, is devoted exclusively to the business of the firm, and should, therefore, not be confounded with the so-called branch offices, which are, in reality, offices for transacting the Washington business of numbers of agents in different parts of the country. All business intrusted to us remains under our own control from first to last, hence that secrecy is maintained which cannot be relied upon where business is transferred to independent practitioners at Washington, who have their own clients to look to; besides attending to the clients of other agents.

Our clerks stationed permanently at Washington are not permitted to act independently of instructions received from the Philadelphia offices, or from Mr. Hubert Howson, or other members of the firm who may be

in that city, the duties of the Washington clerks being restricted to the making of preliminary examinations, procuring promptly copies of official documents, and in the case of the senior clerk, watching and reporting on the progress of pending applications, and following the instructions received relating to the prosecution of such applications.

LIBRARY.



OF the 6000 volumes comprising the library, such as are necessary for daily use are at the offices, 119 South Fourth Street, and the main reference library occupies two large rooms at the residence of Mr. H. Howson.

Our printed catalogue renders a detailed description of the reference library in this pamphlet unnecessary, but the following will give a general idea of its completeness.

37 Encyclopedias and dictionaries (271 volumes) relating to arts, sciences and manufactures.

1270 volumes of magazines and other serials relating to the progress of the useful arts since 1730.

783 books relating to United States Patents, including the monthly volumes of patents, compilations, official gazettes, etc.

A complete set of abridgements of British Patents, British Commissioner of Patents Journal up to date. Also Canadian and other Colonial patent publications.

Complete set of French Patents as far as published, with indexes. Also yearly official index up to date.

H. HOWSON'S



LOWER LIBRARY.



(FROM PHOTOGRAPHS.)

LIBRARIES.



UPPER LIBRARY.



(FROM PHOTOGRAPHS.)

The remaining volumes of the library are technical publications relating to the industrial and mechanic arts.

It may appear at first sight that the organization of our offices, the many appliances for transacting business, and a costly library, would involve the making of extravagant charges. The contrary is the case, however; for just as system and labor-saving machinery tend to the production of superior articles at moderate rates, so does the systematic application of our ample resources tend to thoroughness and exactitude in the performance of our duties, for reasonable fees.

Our main object throughout has been to so organize the office, that we could retain immediate charge of all patent business placed in our hands, and avoid all dependence upon outside help.

It is quite common in conducting patent business to subdivide the work and distribute it to different parties having no joint responsibilities; the drawings being made by one man, who may work for several solicitors, the specifications being prepared by another man, who intrusts its prosecution in the patent office to a so-called associate at Washington, while a fourth man takes charge of such legal duties as the case may call for. When so many men with diverse interests, and acting independently of each other, take part in the business, it is impossible to preserve secrecy and uniformity of action. These can only be maintained where the entire business is performed in one establishment, and under those who are immediately responsible to the client.

SOLICITING DEPARTMENT.



H. HOWSON, SR.'S PRIVATE OFFICE.



CHIEF CLERK'S OFFICE.

SOLICITING DEPARTMENT
OF
HOWSONS' PATENT OFFICES,

119 SOUTH FOURTH STREET,
PHILADELPHIA.

BRANCH OFFICE, 605 SEVENTH ST., WASHINGTON, D. C.

H. HOWSON, Sr.,
ENGINEER AND SOLICITOR OF PATENTS.

ASSISTANT:

H. SMITH,
CHIEF CLERK AND NOTARY.

DRAWING DEPARTMENT IN CHARGE OF

H. HOWSON, Jr.,
DRAUGHTSMAN AND MACHINIST.

SOLICITING DEPARTMENT.

INTRODUCTORY.



THIS portion of our pamphlet will be devoted to a full explanation of the plan we pursue in prosecuting this branch of our profession, and the reasons therefor. Before we proceed to this, however, it may be best to introduce a few remarks about patents and patent property generally.

The first thing for an inventor to understand is his true position, as a patentee, in respect to the public; he must not imagine that he is set apart by the Government for special indulgences or privileges because he possesses inventive faculties; the Government has established laws for the protection of property in invention precisely as it has for the security of other property, and for precisely the same purpose; that is, for the welfare of the community at large, and not for the especial benefit of individuals.

The patent laws are founded on the fact that the granting of exclusive rights to inventors for a limited time "promotes the progress of the useful arts," and consequently benefits the public.

But for the Government to grant exclusive rights to applicants without first inquiring whether they are really the inventors they claim to be, would be to favor individuals at the expense of the community; hence the system of Government examination which is the especial and eminently just feature of the patent laws of this country.

An inventor goes to the proper officer of the Government, and says, "I have an invention here for which, on the ground of its novelty and utility, I demand a title-deed, giving me the sole right, for a certain time, of making, using and selling the invention." The Government officer, in reply to the applicant, says, "We cannot accept your simple assertion. You may think you have made an invention, but it is probable enough that you are mistaken. The public or prior patentees may have something to say about the subject; and as the servant of the public, I must see whether your invention is not in whole, or in part, already public property, or the subject of an existing prior patent, or whether you have not claimed more than you are entitled to. You cannot have a title to that which is already public property, or to that which some one else has already acquired a good title to; we will therefore examine the records, and unless we find proof that you are not entitled to a patent for what you demand, you shall have it."

If the result of the examination is favorable to the applicant, the patent must be granted.

But, of course, the Government cannot guarantee the validity of the patent. The possession of a title-deed does not preclude the possibility of questions of right. The inventor's title-deed is his patent, and it is presumptive evidence of his right to all he claims in that patent, and nothing more.

The system of examination prior to granting patents greatly increases the weight of this presumption in the patentee's favor, but does not by any means make it conclusive; and it is simply impossible that any system

of examination should have that effect. It is practicable to determine—with some approach to accuracy—whether an invention has or has not been previously patented or described in a printed publication in this or some foreign country. A sufficiently large corps of competent examiners, and well-classified records make this possible; yet, even here, oversights or errors of judgment may and do occur.

But a patent is invalid, not only if the thing patented has, before the patentee's invention, been patented or published here or elsewhere, but also if it has been, prior to his invention, used publicly, that is openly, though to ever so limited an extent, by other persons in this country, or if, after his invention, but for more than two years before his application for a patent, it has been publicly used or sold with his knowledge and consent.

Now these are questions which it is not practicable, as a rule, to pass upon before the grant of a patent; the requisite proofs are not in the circumstances under which applications for Letters Patent are made, accessible, and consequently the examination is not directed to these points.

It is a fallacy, therefore, to suppose that the grant of Letters Patent constitutes a warranty of title.

The grant is without warranty, and at the risk of the grantee. All that the Government undertakes to do before the grant is to protect the public, and strengthen the patentee's evidence of title, as far as is practicable, by an examination of domestic and foreign patents and publications, refusing the patent altogether if this search clearly shows the invention to be old, or if the invention

appears to be only partly anticipated, then restricting the grant to that part which seems to have been neither patented nor published before. This is a great service to the patentee, and is performed infinitely better, and more cheaply, than he could make the like search himself, or have it made for him by private parties; but, as we have stated, it cannot and does not ensure his title.

The abolition of the examining system has been advocated, but we think that any departure from a practice which gives to a patent a status not attainable without official examination would be a calamity.

The main duties which devolve upon a solicitor of patents when an invention is submitted to him, are,

First, To determine by preliminary examination what prospect there is of obtaining a patent, and what kind of patent may probably be granted.

Second, If the prospects of obtaining a patent are good, and the inventor elects to proceed with the application, to prepare a specification and with very rare exceptions, a drawing.

Third, The prosecution of the application after it has been filed; this duty including investigations in case of rejection, and the preparing of arguments, amendments, etc., to meet or combat the views of the examiners.

Every inventor should bear in mind that his first success in obtaining a sound patent, and his second success in deriving reasonable remuneration for his invention when patented, depend mainly on the manner in which these duties are performed.

PRELIMINARY EXAMINATIONS.



FROM the establishment of this office, in 1853, it has been our practice to invite inventors to consult us as soon as they have conceived what they suppose to be an invention.

We do not require a model to illustrate the invention; a simple sketch, or even an explanation given verbally or in writing, will, in many cases, suffice to enable us to understand it.

Large sums of money are wasted in the premature making of expensive models, which, on examination, prove useless, because the inventions they represent are not new.

In many cases we are enabled to give from memory, without charge, a reference which will show the invention to have been anticipated. Our senior partner has been engaged in mechanical and scientific pursuits for many years, and has necessarily acquired a fund of information relating to the industrial arts, and this information he is ready to draw upon without charge for the benefit of the inventor consulting him. Scarcely a day passes without presenting the opportunity of advising an inventor not to incur expense in developing his invention.

Whenever we have a doubt as to the patentability of an invention, we recommend a preliminary examination, to determine not only whether there is a probability of securing a patent, but whether a patent with some substance in it can be procured. For this duty, which is

mainly performed at our branch office, we charge a fee of *five* dollars, which sum, if the application for a patent is made, will be deducted from the agency fee therefor.

In three or four days after receiving the particulars of an invention we can mail to the inventor a report pointing out and illustrating such references as appear to have a bearing on his case, or the inventor can call at the office and examine for himself, in the monthly volumes of Patents, or other books, the references pointed out.

Inventors should distinctly understand what is meant by this preliminary examination. It does not mean a thorough investigation of the prior state of the art to which the invention relates (see Searches and Reports); this would in many cases involve the labor of days, perhaps of weeks, in the perusal of domestic and foreign records, and for this a fee of five dollars would be totally inadequate. The search is made with the view of ascertaining approximately whether the alleged invention has been the subject of a patent in the United States.

While a preliminary examination, therefore, is comparatively superficial, and does not guarantee a patent, it is, with rare exceptions, the means of procuring reliable information relating to prior United States patents, and often saves much expense in the preparation of models and the making of applications, and much loss of time and harassment of mind.

Caution in applying for patents has always been characteristic of this establishment, the present proportions of which may be attributed in a great measure to the strict observance of this rule.

MODELS.

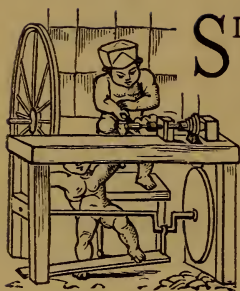

SINCE the first edition of this book was published, the rule relating to models has been so far modified that they are now required in comparatively few cases. For many years the senior member of this firm advocated the abolition of the model system, and finally presented to Congress a petition, in his argument relating to which, the following grounds were taken in favor of the abandonment of models in a majority of cases :

That the making of these models is a serious tax on inventors, involves the premature exposure of inventions, and needless delay in making applications for patents, and detracts from the revenue of the Patent Office, because the demand for models frequently deters inventors from making applications.

That models are not, as a rule, necessary for attorneys in preparing applications for patents, or for Examiners of the Patent Office in the performance of their duties.

That, with rare exceptions, complete, well-executed drawings afford more ready means of determining the character of an invention, and should be, in any case admitting of them, sufficient for the interpretation of the specifications forming part of the patent.

That owing to the furnishing of models, there is a tendency in the Patent Office to admit drawings which are wanting in fullness and perspicuity, and which would

not be admitted in the absence of models,—an evil resulting in the delivery of patents which cannot be easily understood without the aid of models.

The bill presented with this petition failed, with other patent bills, but the present law makes the requirement of a model discretionary with the Commissioner, who established the following rule, September 15, 1880 :

“ A model will not be required or admitted as a part of the application until, on examination of the case in its regular order, the primary examiner shall find it to be necessary or useful, and shall file a written certificate to that effect, which will constitute an official action in the case. From a decision of the primary examiner overruling a motion to dispense with a model, an appeal may be taken to the Commissioner in person.”

The result of a year's enforcement of this rule has been the making of official examinations quite as well without models as with them, a large increase in the number of applications, and a saving to applicants of the time and expense formerly consumed in the making of useless models.

This salutary measure was vigorously opposed by a number of Washington attorneys, who even now that the system has been modified, issue circulars urging inventors to go to the unnecessary expense of making models.

We never require models in preparing applications for patents. If the invention is for a small device or machine already made, a sewing-machine for instance, it can be placed in our hands as a guide in preparing the drawings; but in at least 50 per cent. of the applications

filed through these offices since the enforcement of the rule, the drawings have been made either from sketches made by our draughtsmen in different manufactories, or from rough sketches made by the inventors themselves, or from working drawings.

As the senior member of this firm is a practical mechanical and civil engineer, he can readily instruct his draughtsmen how to put into proper shape inventions represented by crude sketches and brief explanations, a moderate additional fee being charged for the time consumed in such services.

Models are occasionally demanded, but we do our best to render this requirement unnecessary by paying special attention to the making of very complete drawings with perspective views. Occasionally extra sheets of drawings are required for this purpose, in which case we charge a reasonable additional fee, which is always cheerfully paid, as they are much less costly than a model.

SPECIFICATIONS AND CLAIMS.



WHEN an inventor asks for a patent, he must present with his petition and oath a written description of his invention, in "full, clear, and exact terms;" and he must "particularly point out and distinctly claim the part, improvement or combination which he claims as his invention or discovery."

This is the specification, which is to form a part of the printed patent, when granted; it is to be the patentee's

published definition of the scope of his protection, and is to determine whether the patent is good or bad.

The inventor must decide for himself, or through his solicitors, what kind of protection he asks for; the Government authorities cannot help him in deciding how much he shall claim. They will take care that no patent shall be granted with a specification claiming more than the applicant appears to be entitled to. If he claims less, if his specification is badly framed, if it omits proper mention of important features, if it fails to properly distinguish what is new from what is old, if the claim is too narrow, the patent will be defective, and will fail to give the desired protection; and for this no one is to blame but the patentee himself, or his solicitor.

It might be supposed that inventors would intrust the preparation of documents of such vital importance as specifications, to the most proficient experts, but the truth is that a very large proportion of the specifications filed in the Patent Office are butchered documents; and this is by no means peculiar to this country, for patents granted in England and France frequently exhibit a total lack of proper qualification on the part of those who prepared the papers.

Inventors have been cautioned by the authorities of the Patent Office, on this subject. As far back as 1852, Commissioner Burke told them that, "No great aid is to be expected in drawing up the substance of the specification, from any forms. The character of the devices described varies so widely, and the details to be embodied demand such a different consideration and expression in different cases, that the language adopted on one

occasion can rarely be employed on another without great modification.

“ There is hardly any class of documents in preparing which so little aid is to be derived from precedents ; none where more depends upon skill, experience, and ingenuity, or where these are more indispensable.”

Judge Mason warned inventors on the same subject. Commissioner Fisher repeated the same warning in his usual forcible style ; and as recently as March of last year, Commissioner Spear published the following :

“ A large percentage of the cases filed in the office are prepared by men who have none of the requisites named, and little knowledge beyond mere forms. These are often subordinates dismissed from the office, or from private firms, for incompetency or fault.

“ Inventors are therefore urgently advised to avoid illiterate attorneys who advertise to work at the cheapest rates, but whose services are dear at any price, and to seek the aid of those whose experience and technical and legal knowledge are based on a liberal education, and who are in good standing at the Patent Office and before the country.”

As we stated in our preface, it is quite common for solicitors to scribble out or dictate in a few minutes something called a specification, whereas hours of careful study and cautious writing should be devoted to the subject.

As regards our own practice, we never have done and never intend to do, this sort of reckless work ; we cannot afford to do it. We expect to devote to every case the careful consideration and forethought for which

we are paid ; and we may state that it is no uncommon thing at our offices to write a specification three or four times over, and, in cases of intricate character, we frequently print the specifications.

We contend that the duty of a solicitor of patents, in preparing a specification and accompanying drawing, does not end with a description of the invention as submitted to him by the inventor, in the shape of a model or drawing. It is his further duty to look out for weak points, to introduce such views and descriptions of modifications as will pave the way for substantial claims ; in fact, to present the case in the best possible light to the Patent Office.

Our manner of dealing with clients in preparing applications, may be best understood by the following quotation from our Mr. H. Howson's book, " Patents and the Useful Arts," in which he undertook to caution inventors as to the treatment they ought to receive from their attorneys.

" Inventors may save themselves from the many pitfalls which beset them as patentees, and may acquire much salutary information, by observing the following instructions :

" Never sign blank petitions for applications for patents ; insist upon examining the specification and drawings before the application is signed and filed, noting especially the character of the claims. You may be told that you cannot understand them, but you have at least a right to try and understand them, and if you cannot, your attorney ought to explain them.

" Keep a copy of the specification, or at least of the

claims; and bear in mind that the protection you acquire by a patent will depend upon the claims which are allowed.

“After your application is filed, insist upon knowing every step taken in the prosecution of the case.”

In concluding this chapter we would direct the attention of inventors to the warnings given in recent decisions of the United States Supreme Court as set forth in the chapter relating to reissues, on pages 49 to 52.

DRAWINGS.



THE Drawing department of these offices is under the direction of Mr. H. Howson, Jr., an expert draughtsman, whose mechanical training especially qualifies him for the duty of receiving the explanation of inventors, and directing those in his charge how to display inventions to the best

advantage.

According to his usual practice he will, on request, visit any manufactory in the city or neighborhood, and for stipulated fees and expenses will visit any distant point, to examine and obtain particulars of machinery and apparatus,—a practice which has proved to be of advantage both to our clients and ourselves; for by the payment of moderate charges, manufacturers can save much valuable time which would be required in visiting our offices for consultation, or in conducting tedious correspondence; while on the other hand, such information

as to the minutiae and operation of inventions is communicated to us, that we are enabled to prepare accurate specifications and drawings without troubling the inventors to send us elaborate explanations, etc.

In many cases we can send junior draughtsmen to make sketches of machinery, or we will prepare illustrations from working drawings or from rough sketches, the engineering experience of our Mr. Howson, Sr., enabling us to exhibit in proper shape and proportions inventions which are communicated to us in the shape of very rough sketches.



DRAWING OFFICE.

For an ordinary drawing we make no extra charges, but when two, three or more sheets of drawings for exhibiting elaborate machinery are required, or when time is consumed and expenses incurred in obtaining particulars of inventions or reducing rough sketches to proper form, a reasonable extra charge will be made. (See charges, page 72.)

PROSECUTION OF APPLICATIONS.



THIS duty is perhaps the most delicate which a solicitor of patents has to perform, and one which involves grave responsibilities.

As we remarked above, the Government authorities must determine whether an applicant for a patent is entitled to one based on the specification and claim which he presents. For making the examinations on the result of which the grant or refusal of a patent depends, there are twenty-two principal examiners, each having a first, second and third assistant, with a clerk or clerks, and having charge of one of the following classes :

(1.) Tillage ; (2.) Farm stock and produce ; (3.) Metallurgy, distillation, and refrigeration ; (4.) Civil engineering ; (5.) Fine arts, toys and apparel ; (6.) Chemistry ; (7.) Harvesting and milling ; (8.) Furniture, bread-making, and laundry ; (9.) Hydraulics and pneumatics ; (10.) Carriages, wagons, and railway cars ; (11.) Leather-working machines and articles ; (12.) Mechanical engineering ; (13.) Metal working ; (14.) Grinding, polishing, and packing ; (15.) Plastics ; (16.) Electricity, measuring, and optics ; (17.) Printing and paper manufacture ; (18.) Steam engineering ; (19.) Stoves and lamps ; (20.) Surgery and hardware ; (21.) Textiles ; (22.) Guns, ships, and wood-working.

Applications filed in the Office are distributed to the different rooms, and are taken up for examination in the order of their date ; the time which elapses between the

filing and first action varying in different rooms, according to the amount of work in hand, from one to three weeks ; or, in some rooms, it may be at times a month or six weeks before a case is reached.

It is the duty of the Examiner in the first place to see that the application is in proper form, that the drawing and model, if there be any, are sufficient, and that the specification is drawn clearly and exactly, and in accordance with the established rules of the Office.

If there are no defects in the application, or defects have been remedied, the Examiner proceeds with his searches ; he will reject the application if the invention is found to be the subject of a prior patent in this or any other country, or if it is described in any printed publication, United States or foreign, or even if he has a knowledge, derived from any source, of the prior existence of the invention, or he may determine by examination that part of the invention is old, and may reject one or more of the claims ; but inventors must bear in mind that it is no part of his duty to instruct the applicant when his claims are not as broad as they might be.

In this connection, it may be well to introduce the following quotation from the special order of the Commissioner of Patents, August 27, 1878.

“ The Examiners of the Patent Office cannot undertake to do the work of attorneys by rewriting and correcting specifications. Their first duty is to see that the papers are in proper form, to notify the attorney when and where corrections are needed,—and, of course, the more ignorant the attorney, the more corrections are required, and the greater are the annoyance and trouble to which

the Examiner is subjected. It is an Examiner's duty to reject an application if the thing claimed is old, or if the applicant has claimed too much ; but it is no part of his duty to notify the attorney when he has claimed too little for his client."

When an application is rejected, the reasons are given in full in an official letter, citing the references on which the rejection is based.

It is at this juncture that the services of an experienced and painstaking attorney are of the most use to the applicant.

The reckless or incompetent man may get out of the difficulty as speedily as possible, especially if he has a contingent fee, by withdrawing claims, introducing others which can be of no value, inserting dangerous admissions in the specification, never stopping to investigate the references, or to inquire whether the Examiner is right or wrong in his views ; in short, such an attorney is willing to accept anything in the shape of a patent.

With the remark that this is a mode of doing business which we cannot afford to adopt, we will proceed to explain what services our clients, whose cases may be rejected, are entitled to for the fees paid on filing their applications.

It should be understood that complete copies of every application made through these offices are retained, a separate pamphlet or cover being devoted to the papers of each case.

The first papers in the pamphlet are a complete press copy of the original specification and a photograph of the drawing. When an application is rejected, we add the

official letter to the applicant's pamphlet and send him a copy, after which we procure copies from the Patent Office or from our library or other sources, of all references cited in the official letter; and these copies are also pasted in the pamphlet, which is then in complete condition for that careful perusal which a proper prosecution of the rejected application demands.

Further proceedings may in some cases be delayed until an opportunity has been afforded of consulting or corresponding with the applicant as to the bearing of the references.

If after perusal of the references we conclude that the Examiner is mistaken or in part mistaken in his views, we prepare a careful argument and such amendments as seem necessary. In addition to this, in cases which appear to require it, we obtain personal interviews with the Examiner.

In many cases, we come to conclusions totally at variance with those of the Examiner, whose opinions cannot be changed; in such cases we recommend an appeal to the Examiners-in-chief.

Copies of all arguments and amendments, correspondence with the office, etc., are retained, and pasted in the pamphlet relating to them; so that, during all stages of the proceedings before the Patent Office, the pamphlet will form a complete record of the case.

Duplicate copies of all papers are kept in the branch office at Washington for ready reference during the repeated visits made to that city by ourselves or assistants.

Each client is notified, from time to time, of the prog-

ress of his case, by sending him copies of official letters.

FEES.—No additional fees are demanded for the services above described in prosecuting rejected applications before the primary Examiner.

EXAMINERS.



IT may be as well to say a few words here about these officers.

An impression prevails to a considerable extent that the Patent Office is an institution of a rather arbitrary character, that the Examiners are often actuated by a captious opposition to the claims of inventors ; while rumors of favoritism exercised in the Patent Office are not unknown.

Certain practitioners are in part responsible for this. We know from the published opinions of different Commissioners that there is a large number of attorneys practicing before the Patent Office who are not possessed of the proper qualifications for duties they have assumed ; failing to secure patents, or patents of a substantial character, and too ignorant to perceive that this is due to their own short-comings, they abuse the Examiners to their clients.

A Commissioner said of these men in his report for 1869 : “ They have the ear of their client, and to some extent of the public, and much of the misrepresentation of the spirit and character of the work of the office is directly traceable to this source.”

It would be well for inventors to take note of the following :

First.—Nearly all the Examiners and assistants owe their positions to competitive examinations.

Second.—An Examiner stands between the applicant for a patent and the public ; and it is his sworn duty to see to it, as far as he can, that an applicant does not obtain a patent for that which is the property of the public or of a prior inventor.

It may be fairly assumed, from the mode of this appointment, that these Examiners are, with few exceptions, capable of performing their duties, and that the desire of the juniors for promotion and the wish of the seniors to stand well with the heads of the bureau will induce them to perform their duties faithfully and fearlessly.

When an attorney, in consulting with or writing to an applicant whose case may have been rejected, accuses the Examiner in charge of incompetency, obstinacy, or corrupt motives, it will be well for the applicant to inquire how much of the trouble is due to the attorney himself.

Naturally enough there is much difference of opinion among Examiners as to questions of patentability, and there may be solitary instances in which the action of an Examiner may savor of injustice, or incompetency, or a desire to manufacture patent law of his own, or to tantalize an attorney ; but these cases are rare. It is the experience of the writer, after a practice of a quarter of a century, that Examiners, as a rule, perform their duties as conscientiously as any other judicial officers, and that they are ready to yield to arguments likely to convince any fair and reasonable man.

These remarks may be out of place in a pamphlet like this, but we are anxious that our clients and inventors generally should not harbor a suspicion that they are liable to unfair treatment at the hands of officers of the Patent Office.

The opinions of Examiners may be adverse to the interests of the applicant, but the latter must remember that there are ample opportunities to appeal from an Examiner's decision.

TIME REQUIRED TO OBTAIN PATENTS.



NO specified time can be named. The case may be acted on in a few days after it is filed, or it may not be reached for several weeks. It may be rejected in such terms that much time must be devoted to meeting the objections with proper arguments, etc.; it may be rejected a second time, and an appeal may be necessary, so that it is next to impossible to state in advance how soon a patent may be allowed; but an applicant may be certain of this, that it is a comparatively easy and expeditious matter to procure a bad patent with miserable claims, and that it is often a matter of time and labor to obtain a good patent with broad claims.

The broader the claims of an application, the more caution will the examiner exercise in the performance of his duties; and the more urgently an application is prosecuted in the best interest of a client, the more time must be devoted to it by the attorney; hence inventors may

be assured that when there is apparent delay in the prosecution of cases at these offices, they must not attribute it to neglect, but to that cautious and deliberate action which all rejected cases demand.

APPEALS.

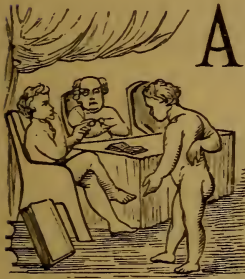

AFTER a second rejection, by the principal Examiner, of an application or of one or more claims of an application, on the same references, an appeal can be taken to the Examiners-in-chief on payment of a Government fee of \$10.

Three Examiners-in-chief constitute a Board of Appeal, the modification or abandonment of which has been from time to time suggested.

To change or abolish existing organizations is a common and easy suggestion, but one not deserving much attention unless the parties making it are able to suggest at the same time some plan which will supply the place of that to be abolished to better advantage.

So far we have not heard of any very promising suggestion in that direction.

Of course these appeals should be taken with caution and with a proper spirit. If they are made without due deliberation, or are actuated by a perverse opposition to the Examiner, or a spirit of captiousness, the applicant is very likely to be the sufferer.

Our practice is, after we have made up our minds positively that an applicant is entitled to a claim or claims which have been rejected, to be unyielding and

persistent, and after failing to convince the Examiner that we are right, to recommend an appeal to the Examiners-in-chief. These appeals are prosecuted by oral arguments and by briefs, which we prefer to print for the convenience of the members of the Board.

FEES.—An estimate will always be given of the fees required in appeal cases, the estimate including the Government fee of \$10, oral argument before the Board, and cost of printed brief.

APPEALS TO THE COMMISSIONER.

From an adverse decision of the Examiners-in-chief, an applicant can appeal to the Commissioner in person on payment of a Government fee of \$20.

An appeal to the Commissioner is rarely required, and it is a very unusual case indeed which suggests taking advantage of the law providing an appeal from the Commissioner to the Supreme Court of the District of Columbia.

BILLS IN EQUITY TO OBTAIN PATENTS.

It is hardly necessary—except to exemplify the extreme care which our patent laws take to provide against possible mistake in the refusal of patents—to mention this provision, so rare must the occasions be in which it is necessary or advisable to take advantage of it. Section 4915 of the Revised Statutes enacts that when a patent on application is refused, either by the Commissioner or by the Supreme Court of the District of Columbia, on appeal from him, the applicant may have remedy by Bill in Equity in a Circuit Court of the United

States. If the court adjudge the petitioner entitled to a patent, the adjudication, a copy of it being filed in the Patent Office, shall authorize the Commissioner to issue the patent. The expenses of the proceeding, whether the result be in favor of or adverse to the applicant, are to be paid by him.

FEES for these appeals will vary according to the character of the cases, but estimates can always be given in advance.

INTERLOCUTORY APPEALS.

When an Examiner, in passing in the first place upon the insufficiency of the application in the matter of form, has determined that a specification or claim is improperly drawn, or that the drawings or model, if there be any, are imperfect, or comes to other conclusions of analogous character, before examining an application on its merits, if he persists in his opinions, an appeal may be taken directly to the Commissioner without payment of a Government fee.

These interlocutory appeals would appear to be unnecessarily frequent, and are caused in many cases by a disposition on the part of attorneys to take as a personal affront any change which the Examiner may desire in the papers submitted to him. Of course, delay and expense are incurred in making these appeals, and these might be obviated in many cases by the exercise of a little discretion.

When an Examiner makes such demands as those referred to, the first thing for an attorney to determine is whether a compliance with the demand will jeopardize the interests of the applicant; if it will not, the feelings

of the attorney should be discarded and the interests of the client consulted, by making the desired alterations; and only if the alterations will work any injury to the client, should the appeal be made. This is the practice we follow, for clients gain nothing by mere fractious opposition to harmless requirements.



INTERIOR OF BRANCH OFFICE,
915 F Street, Washington, D. C.

REISSUES.

(IN THE LIGHT OF RECENT DECISIONS.)

Copyrighted 1883 by Howson & Sons.



THE most important, and we think most salutary changes which have been made in patent practice, are, *first*, the virtual abolition of models, a subject referred to elsewhere, and, *second*, the more recent change relating to Reissued Patents, brought about by the decision of the United States Supreme Court in the case of

Miller *vs.* The Bridgeport Brass Company, the case of James *vs.* Campbell, and other decisions.

The recent enormous increase in the number of applications filed, and number of patents granted, may be attributed mainly to these two changes.

The abolition of an onerous tax imposed by the demand for useless models, necessarily stimulated invention, and the action of the Supreme Court has opened to the ingenious, avenues which had previously been closed by monopolies based on Reissued Patents.

The day has passed for the favorable entertainment, by the Courts, of patents expanded by reissue long after the original grant; such patents can no longer be available instruments in the hands of speculators for harassing manufacturers and patentees. There is no longer any hope for the patentee who has failed to secure all that he is entitled to, and who has neglected to promptly remedy the defects.

In the case of *Miller vs. The Bridgeport Brass Company*, the Court said :

“ By a curious misapplication of the law (relating to reissues), it has come to be principally resorted to for the purpose of enlarging and expanding patent claims. And the evils which have grown from the practice have assumed large proportions. Patents have been so expanded and idealized, years after their first issue, that hundreds and thousands of mechanics and manufacturers, who had just reason to suppose that the field of action was open, have been obliged to discontinue their employments, or to pay an enormous tax for continuing them.”

“ Now whilst, as before stated, we do not deny that a claim may be enlarged in a Reissued Patent, we are of opinion that this can only be done when an actual mistake has occurred ;—not from a mere error of judgment, but a real bona fide mistake, inadvertently committed ; such as a court of chancery, in cases within its ordinary jurisdiction, would correct. Reissues for the enlargement of claims should be the exception and not the rule. And when, if a claim is too narrow, that is, if it does not contain all that the patentee is entitled to, the defect is apparent on the face of the patent, and can be discovered as soon as that document is taken out of its envelope and opened, there can be no valid excuse for delay in asking to have it corrected.”

Again the Court said : “ These afterthoughts, developed by the subsequent course of improvement, and intended, by an expansion of claims, to sweep into one net all the appliances necessary to monopolize a profitable manufacture, are obnoxious to grave animadversion.

If a patentee who has no corrections to suggest in his specification except to make his claim broader and more comprehensive, uses due diligence in returning to the Patent Office, and says 'I omitted this,' or 'My solicitor did not understand that,' his application may be entertained, and on a proper showing, correction may be made. But it must be remembered that the claim of a specific device or combination, and an omission to claim other devices or combinations apparent on the face of the patent, are, in law, a dedication to the public of that which is not claimed. It is a declaration that that which is not claimed is either not the patentee's invention, or, if his, he dedicates it to the public."

In the case of *James vs. Campbell*, the Court said :

"Of course, if by actual inadvertence, accident, or mistake, innocently committed, the claim does not fully assert or define the patentee's right in the invention *specified in the patent*, a speedy application for its correction, *before adverse rights have accrued*, may be granted, as we have explained in the recent case of *Miller vs. Bridgeport Brass Company*."

One of the evils due to the unrestricted Reissuing of Patents in past years, has been the careless presentation and prosecution of applications for patents.

Facilities for reissuing patents had engendered in the minds of inventors a belief that a patent could be repaired and re-repaired at any time when it was worth while to do so, or when the efforts of others suggested a Reissue, and that the style of specification, claims, and drawings, was not matter for grave consideration. The very man who would measure every word of an agree-

ment, or other document relating to ordinary property or money matters, would be heedless in the criticism of papers which defined his patent property, and in a great measure determined its value.*

That this is the case is evidenced by the statement published last year, after careful inquiry in the Patent Office, that "on an average 14 per cent. of the applications were prepared in a masterly manner, 26 per cent. were fair to medium, 30 per cent. passable to poor, and that the remaining 30 per cent. were very bad or butchered."

Two warnings, which the inventor must heed, are given by the above decisions:—

First, he is taught that he can no longer afford to present to the Patent Office clumsy papers prepared by incompetents; and that a hasty, impatient prosecution of his application, and a failure to insist upon the allowance of claims to which he is entitled, may be disastrous to his interests.

Second, that the most careful scrutiny of his patent should be instituted immediately after the grant, and if defects due to inadvertence, accident, or mistake occur, that he must seek the prompt remedy suggested by the decisions of the United States Supreme Court.

It should be stated in conclusion, that the Rules of the Patent Office relating to Reissues have been altered to accord with the above-mentioned decisions.

*H. Howson on Reissued Patents—A Warning to Inventors. Published by T. and J. W. Johnson & Co.

DISCLAIMERS.

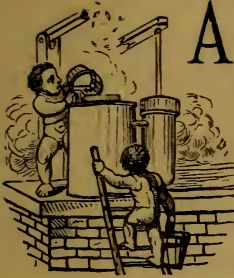

ANOTHER remedy for patents defective because they claim more than the patentee was first to invent, is that of disclaimer.

The law provides that when by mistake, and without fraudulent intention, a patentee has claimed more than he was the first inventor of, he or his heirs, or his assigns of the whole or a sectional interest in the patent may, upon payment of a Government fee of ten dollars, file in the Patent Office a written disclaimer attested by one or more witnesses, and disclaiming such parts of the thing patented as he or they may not wish to claim or hold under the patent, and that thereafter this disclaimer shall be considered as part of the original specification, to the extent of the interest of the party or parties filing it.

This remedy by disclaimer is a process of excision, and applicable therefore to those cases only, in which the cutting out, from the original specification, of the objectionable matter, will still leave in the patent a definite and distinguishable claim or claims to some material or substantial part of the thing originally patented.

The distinction between a patent which can be thus limited to its proper scope by "disclaimer," and one in which the end can only be accomplished by reissue, is that while the latter in its original shape is altogether invalid, because the specification does not definitely distinguish what the patentee was entitled to, from that which is claimed without right, the former is not so,

but is made by the terms of the law valid for all that part which is truly and justly the patentee's own, because that part is a material or substantial part of the thing patented; that is, it constitutes in itself a patentable invention, and is expressly and distinctly claimed.

Where a patent which is too broad can fortunately be cured by disclaimer, it is not only proper, but to the interest of the patentee, that the step should be taken without unnecessary delay. The law provides that if in any suit upon such a patent, judgment or decree shall be rendered for the plaintiff, no costs shall be recovered unless the proper disclaimer has been entered at the Patent Office before the commencement of the suit. And further, that if in any such suit it appears that there has been unreasonable neglect or delay to enter a disclaimer, the plaintiff shall not maintain his suit at all.

Whether a disclaimer will fully meet the requirements of any particular case, is a question to be carefully and intelligently weighed.

FEES.—Our charge for advising upon and attending to the drawing and filing of a disclaimer, necessarily varies with the varying nature of the cases.



HOSPITAL CASES.



THIS may appear to be a singular name to use in connection with any branch of patent business, but it is certainly a most expressive term to apply to a class of cases which have been so damaged by mismanagement as to require remedial treatment and curative efforts.

These cases may be classed as follows :

First.—Applications the prosecution of which has been neglected or mismanaged by attorneys.

Second.—Applications which have been made by inventors themselves, who begin by fancying that the preparation of the necessary papers for an application is a simple matter, and the prosecution of an application easy, but end by finding that professional help is necessary.

In every city and considerable town, indeed in almost every village, there is some overwise man, some jack-of-all-trades, who is ready to offer his services for any kind of work, patent soliciting included. With a copy of the rules and regulations of the Patent Office, and a very little dangerous smattering of patent law, he volunteers to assist inventors by the preparation and filing of applications ; and the result in most cases is either failure to secure a patent at all, or the obtaining of a patent which is not worth the paper on which it is printed.

We have the authority of one of our best Commissioners for saying “that a large percentage of the cases filed in the office are prepared by men who have no

qualifications for such duties, and little knowledge beyond mere forms; illiterate men, who advertise to work at the cheapest rates, but whose services are dear at any price."

The duty of curing these hospital cases is not always a pleasing one; for in many instances the papers are so botched that an effective cure is out of the question.

Of late years, so many cases of this character have been placed in our hands, that we have been compelled to adopt a stringent system of charges, and to treat them as new cases, as far as agency fees are concerned, a portion of the fee being demanded in advance to cover the expense of the necessary searches. In cases of great hardship, however, we know how to exercise proper liberality. When an unsuccessful applicant for a patent desires to put his case in our hands, he can send us a fee of \$5 with a power of attorney, the form of which we will furnish on request.

This paper will enable us to examine and obtain copies of the papers on file in the Patent Office relating to the application, after perusing which we will send a report to the applicant.



REPORTS AS TO THE VALIDITY OF PATENTS.



THE duty of reporting upon the validity of a patent is one of great importance.

A careful perusal of the patent itself may enable us to decide that, owing to a bad specification and wretchedly drawn claims, it is of no value. It is not proper, however, to stop here and base a decisive report of the condition of the patent upon a mere inspection of the deed itself, for it may well be that the patentee was entitled to better claims than those appearing in the deed, and that such claims might properly be secured by reissue. Whether this be the case or not, must be determined, in the first instance, by an examination of the papers relating to the patent, on file in the Patent Office. These may afford prompt and satisfactory proofs that the patent covers quite as much as the patentee was entitled to, or they may indicate that the patentee appeared to be entitled to more than he claimed; if the latter, a further investigation should be prosecuted.

Again, a patent may appear on its face to be of a most substantial character, with sweeping claims; but there can be no more fatal mistake than to take for granted that the patentee was entitled to all he claims.

It is a very common mistake to purchase patents on the strength of their formidable appearance, and without the exercise of the same precautions which are exercised prior to the purchase of other property. This may be attributed to the confidence which a patent engenders

in the minds of those who are not familiar with the subject.

As on the one hand, a bad patent may result from the unskillfulness or carelessness of the patentee or his professional adviser, and a failure to claim all that he might have claimed; so, on the other hand, a patent of formidable appearance may have been improperly or improvidently granted. During the official examination, a reference may have been misplaced, and the most strict and painstaking Examiner may, by inadvertence, overlook a reference, or a reference damaging to a patent may be found in a class of cases, or in publications, totally apart from the class to which the Examiner's duties are restricted, or the invention claimed in a patent may have been in public and common use without the knowledge of the Examiner.

The history of patent litigation shows that patents are frequently granted for old inventions, and claims allowed to which the patentee was not entitled. While the official examination gives a status to a patent which it could not otherwise have, it is impossible for the office to make such an exhaustive search as will place the validity of a patent beyond question. It will thus be seen that an investigation on which the reputation of a patent is to be based, should not cease with an examination of the official files in the case, excepting when they show beyond a doubt that the patentee has obtained claims quite as strong as the state of the art will permit.

An exhaustive investigation prior to a report on a patent is an arduous, time-consuming task, and a futile one unless a practical familiarity with industrial arts

and with publications relating to manufactures, technical knowledge, and the legal qualifications necessary to apply that knowledge, are brought to bear on the investigation.

All the United States patents relating to inventions of the class to which the patent to be investigated refers, must be perused, not superficially, but thoroughly; then the English and French patents must be examined, publications must be searched, and failing to discover any damaging references by these investigations, it becomes necessary to determine whether there are any patents or published records outside the class to which the invention relates which may contain matter bearing on the patent. This last duty is one which is very commonly neglected, but it is a very important duty; for it is quite a common thing to find references to patents in publications where an inexperienced searcher would not expect to find them.

It is another grave mistake frequently made by novices in patent matters to suppose that the Patent Office with its library contains all the information necessary for a proper search. Patents are quite frequently granted for things which have been long in common use, but have never been patented or appeared in printed publications, and are consequently beyond reach and knowledge of the Patent Office authorities.

It is our practice to conclude our researches prior to making reports, by inquiries in such manufactories as the nature of the invention may suggest.

No city presents better opportunities for conducting such inquiries than Philadelphia, where there is a greater variety of industries than in any city in the world. Our

searches are facilitated by the large and well-selected library previously referred to, as it enables us to examine at all hours published authorities which otherwise could not be reached without spending much time at different public libraries.

Exhaustive researches such as we have described have, of course, different results. In many cases, they place patents on the best commercial footing; in others, they point out to the patentee how to strengthen his patent by reissue or by the purchase of other patents; while in other cases, the searches may exhibit such a prior state of the art, as to show the patent to be quite worthless.

Our fees for such searches and reports are \$75 and upwards, according to the character of the invention, some classes of inventions demanding much more elaborate and tedious searches than others. An estimate will always be given, and payment of the fee will always be required in advance excepting when we are permanently retained by manufacturers and others to attend to their patent business; and this brings us to another branch of our business which may be termed :



PURCHASE, SALE AND PUBLICATION OF PATENTS.

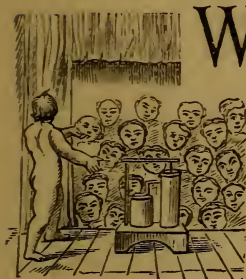

WHILE we are ready to advise as to the purchase or sale of patents, and to prepare necessary conveyances, agreements, etc., relating thereto, we never engage personally in the negotiation of patents, which is entirely apart from the duty of soliciting them, or of conducting suits before the United States Courts.

We are frequently asked about the best mode of disposing of patents, and we may give our views on that subject here.

We have always found that the most successful inventors and owners of patents, have been those who relied upon their own efforts and business qualifications to turn their property to good account. It must always be remembered, however, that a bad patent, or a patent with weak claims, is not as easily disposed of as it was a few years ago; as we have stated in our preface, the public has during late years become more familiar with the true character of patent property; but the owner of a good patent for a valuable invention, a patent endorsed by competent authority, will not have to wait long for a customer, or for the necessary capital to develop it, if reasonable efforts are made to direct the attention of reliable parties to it.

While it may be advisable in some instances to call the attention of the public to patented inventions by advertisements in the papers, nothing can be more dan-

gerous than the premature publication of a patented invention which promises to be of value and importance.

Where there is one true inventor there are four or five pirates or copyists, who, without brains to originate, look out for all published items about novel and startling inventions, or even insinuate themselves into the confidence of the patentee, and then proceed to make what they call improvements, which are simply alterations or trifling additions, and, by becoming claimants for a patent, undermine the property of the inventor and interfere with his sales.



CAVEATS.



MANY persons make the mistake of supposing that a caveat affords for a short time the same protection and security as a patent does for a longer time.

A caveat is a description (accompanied, when practicable, with drawings) filed in the secret archives of the Patent Office, and setting forth concisely and clearly some improvement upon which the inventor desires time to experiment with a view to perfecting it before applying for letters-patent. A caveator is entitled to notice if any application be made for letters-patent for a like invention at any time within a year from the date at which his caveat is filed. He is not, however, entitled to notice of any pending application which may have been filed before the filing of his caveat, nor of any application which may be filed after the expiration of one year from the filing of his caveat, unless the latter shall have been renewed for another year by the payment of a second caveat fee. A caveat may be thus renewed from year to year by the annual payment of a caveat fee.

If while a caveat is in force another person applies for a patent for the same invention, the caveator will be entitled to notice to file his application and to go into interference with the other applicant, for the purpose of proving priority of invention, and of obtaining the patent if he succeed. He must file his application within three months from the day on which the notice to him is

deposited in the post-office at Washington, adding the regular time for the transmission of the same to him. The day when the time for filing application expires is mentioned in the notice or indorsed thereon.

This title to notice is the only privilege which a caveat confers. It does not give any exclusive right in an invention, of which the courts can take cognizance, and therefore does not enable the caveator to sue parties who may make, use, or sell his invention.

We have so little faith in caveats that we believe it would be a benefit to inventors if the law relating to them was abolished.

The safest plan for an inventor is to make a complete application for a patent, with as little delay as possible, and to avoid the expense of a caveat and the delay which a caveat always invites in perfecting an invention.

FEEES.—The cost of filing a caveat through these offices will be \$12, \$15, or \$20, according to the nature of the invention. Payment, with Government fee of \$10, due prior to filing the papers.



PATENTS FOR DESIGNS.



DESIGN patents are entirely distinct from ordinary patents. The latter relate to new machines, devices, manufactures, or compositions of matter; design patents to shape, configuration, or ornamentation.

Artists, designers, and inventors can procure patents for designs for three and one-half, seven, or fourteen years, at their option; the Government fee for the first being \$10, for the second \$15, and for the third \$30.

No model is required for patents of this class. The drawing, however, should be very complete, and the specifications full and clear.

FEES.—Our charges for design patents, exclusive of the Government fees, are \$15, or \$20, or \$25, according to the character of the design. The fee rarely exceeds \$20; and when a number of design patents relating to objects of the same generic character, as, for instance, a series of fabrics, are required, a deduction will be made from the lowest fee above given.



TRADEMARKS, LABELS, COPYRIGHTS.

TRADEMARKS.



REGISTRATION of trademarks in the Patent Office was provided for by Act of Congress of July, 1870, and several thousand trademarks had been registered under this law up to November 17, 1879, on which day the Supreme Court of the United States rendered a decision holding the act

to be unconstitutional.

It must not be supposed that the overturning of this particular Act of Congress had the effect of overturning trademark property, or of changing either the nature of the right, or the remedy for infraction of the right, save only as to the forum in which that remedy must be sought. The act did not *create* trademark property; such property had been recognized and protected in the courts of the various states long before the act. The act did not even take away the jurisdiction of the state courts in such cases, it merely undertook to confer jurisdiction on the courts of the United States; save in this particular, and in the provision of a system of registry, the law of trademarks was not changed by the act, nor any new principle introduced. The state courts continue to have jurisdiction of trademark cases.

The basis of trademark property is adoption and use, by which is meant an actual application of the mark, in the course of trade, to the goods which it is intended to distinguish in the market from other goods of like class coming from other manufacturers or merchants.

Origination or invention has nothing to do with the matter ; the mark may be an old and common word, picture or sign, the right is not to the mark considered by itself, but simply to its use upon certain goods, for the purpose of telling the public that those goods come from the person so marking them. It is not to be understood, however, that any word or words will necessarily constitute a good and valid trademark, because the party may have been first to use them in that particular connection ; for example, a manufacturer or merchant cannot, as a rule, so appropriate words which are simply descriptive of quality, and which may therefore be truthfully and properly used by other manufacturers or merchants issuing like goods of like quality, and there are other restrictions and qualifications of the right which have been evolved in many judicial rulings, during a long period of years.

To enter into a dissertation on trademark law, however, would be out of place here. We merely wish to correct any impression that might otherwise exist, that the Supreme Court decision to which we have referred has the effect of vitiating trademark property, or of putting such property beyond the pale of protection.

In March, 1881, Congress, under the clause of the Constitution providing for the regulation of commerce, passed an act, enabling owners of "trademarks, *used in commerce with foreign nations or with the Indian tribes,*" to obtain registration of such trademarks, by complying with requirements similar to those provided for under the law of 1870. Trademarks *not* so "used in commerce with foreign nations or with the Indian tribes" cannot be registered, however, under this Act.

The certificate of registration will continue in force for thirty years.

Fees—\$40, including Government fee of \$25.

LABELS.

By Act of June 18th, 1874, it was provided that certain prints and labels should be registered in the Patent Office.

By the word *print* is meant any device, picture, word or words, figure or figures (not a trademark) impressed or directly stamped upon an article of manufacture to denote the name of the manufacturer, place of manufacture, style of goods, or other matter.

The word "label" means a slip or piece of paper, or other material, to be attached to manufactured articles, or to bottles, boxes, or packages containing them, and bearing an inscription (not a trademark), as, for instance, the name of the manufacturer, place of manufacture, the quality of goods, directions for use.

The words "articles of manufacture" to which such print or label is applicable by said act, mean all vendible commodities produced by hand, machinery or art.

The certificate of such registration will continue in force for twenty-eight years.

FEES.—\$10, Government fee of \$6.

COPYRIGHTS.

Although the Patent Office has no control over copyrights, we may refer to them now because there is much confusion in the popular mind as to what are the differences between copyrights, design patents, trademarks and labels.

The present copyright act permits any citizen or resident of the United States who shall be the author, inventor, designer or proprietor of any book, map, chart, dramatic or musical composition, engraving, cut, print or photograph or negative thereof, or of a painting, drawing, chromo, statue or statuary, and of models and designs *intended to be perfected as works of art*, to secure a copyright therefor, for twenty-eight years, and gives a right of renewal to himself or widow or children for fourteen years more; and authors may reserve the right to dramatize and translate their own works. The statute also gives the author of a dramatic composition, upon complying with the requirements of the statute, the sole liberty of publicly performing it or causing it to be performed, or represented by others.

The aid of an attorney is not required to secure a copyright; all that is necessary is for the applicant to send two copies of the title of the book or other article, or a description of the painting, statue, etc., to the Librarian of Congress *before publication*, with a fee of 50 cents, or of \$1 if he desires a certificate of the record; and two copies of the book, or in case of a painting, etc., a photograph of the same, must be sent to the Librarian *within ten days after publication*.

The limits of this pamphlet will not permit us to enter into a lengthy discussion of the confusion or apparent confusion between the design act and copyright laws, or to point out the limits of the application of the different acts, as determined by the action of the authorities; but as we are frequently consulted about these matters,

we will endeavor to throw some light on the subject by explaining how far it is possible for one man to acquire different kinds of protection upon or in connection with one and the same thing.

We will suppose that a man has invented a machine, say for the manufacture of bolts.

First.—The mode of treating the heated metal may be new, irrespective of the machinery employed, in which case he would be entitled to a patent for the mode or process.

Second.—If the machine is new, he would of course be entitled to a patent with claims for the devices composing the machine, or different elements of the machine.

Third.—The bolt itself might be a new bolt differing from those heretofore made, and possessing peculiar novel and useful features, in which case he would be entitled to a patent for the bolt as a new article of manufacture irrespective of the process and machine.

All these instances relate to ordinary patents granted for seventeen years; and we may remark here that the first and most important duty which an attorney has to perform on investigating an invention submitted to him, is to decide whether it can be best covered by a process patent, machine patent, or by a patent for the product, or whether claims should be introduced for both the process and machine, or the process or product in one patent, or whether separate patents should be applied for.

Fourth.—The inventor, in designing the machine, may make a frame of peculiar shape and of ornamental character.

For this, if new, he would be entitled to a design patent.

Fifth.—He might desire to give his machine, if he manufactured it for sale to others, or to the products of his machine, a peculiar name, the “Keystone Bolt Machine,” or “Keystone Bolts;” this would be a trademark, providing always that the name was first adopted by him in connection with that particular class of machines or goods.

Sixth.—He might adopt a special trade label to be attached to the machine, or to the products of the machine, or to packages of the product.

This label would be a proper subject for registration, under the Act of June 18, 1874.

Seventh.—While we are not prepared to say that a simple photograph of the machine would be a subject for a copyright as a work of art, there can be no doubt that a pictorial composition of which the machine should constitute a prominent element might be copyrighted as a work of art, and certainly a pamphlet descriptive of the machine would be a proper subject for a copyright.

We might extend these remarks to a much greater length, but the above will suffice to give a general idea of the applicability of patents, design patents, trademarks, label registrations, and copyrights.

CHARGES.

SOLICITING DEPARTMENT.

In preparing and prosecuting applications for patents, we avoid extra charges as far as possible, our services for the stated fees including, in all ordinary cases, preliminary examinations, specification, drawing (one sheet), notarial fee, packing, express charges, and correspondence.

As we have a confidential clerk stationed at Washington, and as that city is visited by a member of the firm at frequent intervals, we do not tax our clients with the charges frequently made by attorneys for visiting Washington, and for personal interviews with Examiners in prosecuting ordinary applications.

The entire cost of a patent at these offices, where the invention is simple, is \$75, including first and second Government fees, \$55 being payable before the papers are sent to the Patent Office.

Additional fees will be required when extra sheets of drawings are demanded with the view of avoiding the expense of models; when draughtsmen are sent out of the city, when time is consumed in putting crude sketches into proper shape; when a specification and drawings are unusually elaborate and intricate; in cases of appeal, and when the absence of the heads of the firm from the city is required in special cases.

Although these provisions are made for extra charges in exceptional applications, it should be understood that the entire cost of a patent in the majority of cases does not exceed the above sum of \$75.

That our fees are looked upon as reasonable in view of the services rendered, and the discarding of extra charges frequently made by solicitors, is evidenced by the names, given hereafter, of many prominent and successful inventors for whom we have transacted business for many years.

It should also be distinctly understood that the fees referred to hereafter are due (with the exception of the second Government fee of \$20, mentioned in the second item) after the specifications and drawings have been prepared, and before we are saddled with the responsibility of prosecuting a case before the Patent Office ; that is, before the application is filed.

This plan of charging is invariably practiced by patent solicitors of standing and experience, and such as possess the confidence of successful inventors and manufacturers who understand the value and importance of the proper prosecution of applications, and of carefully drawn and valid patents.



NOTE.—For summary of charges see page 10.

LAW DEPARTMENT.



C. HOWSON'S OFFICE.



HUBERT HOWSON'S OFFICE.

LAW DEPARTMENT
OF
HOWSONS' PATENT OFFICES,
119 SOUTH FOURTH STREET,
PHILADELPHIA.

CHAS. HOWSON,
ATTORNEY-AT-LAW AND COUNSEL IN PATENT CASES.
(Twelve years' practice before the United States Courts.)

H. HOWSON, Sr.,
ENGINEER AND CONSULTING EXPERT IN PATENT CASES.
(Twenty-six years' practice before the Patent Office.)

ASSISTANT:
HUBERT HOWSON,
ATTORNEY-AT-LAW.

LAW DEPARTMENT.**INTRODUCTORY.**

Charles Howson, attorney-at-law, and counsel in patent cases, has, for ten years past, had immediate charge of this department, and is assisted by Hubert Howson, attorney-at-law; the senior partner, Henry Howson, who has had an experience of many years in preparing patent cases for trial, and who is a practical engineer, acting as advisory counsel and consulting expert.

The duties involved in the management of this department are the conducting of suits relating to patents, trademarks, and copyrights, before the United States Courts, interferences before the Patent Office, extension cases before Congress and the preparation of agreements, assignments, and other deeds relating to patents. Our engagements in the above duties compel us to decline all general law practice.

The published reports indicate by no means a large proportion of patent cases tried and decided.

Sometimes suits are commenced as a threatening measure, with no intention of proceeding beyond the filing of the bills of complaint and issuing subpoenas.

Other suits are dropped after the filing of answer to the bill of complaint, because the plaintiff or his counsel is satisfied by the terms of the answer that it would be fruitless to proceed; other cases are settled by amicable arrangements between plaintiff and defendant (a wise proceeding when it can be brought about), and others again are dropped after much expense has been incurred, owing to the late discovery by the plaintiff that

the charge of infringement cannot be sustained, or by the defendant that it would be futile to further resist.

Large sums are wasted yearly in patent litigation, and this waste may be attributed largely to the premature action of those concerned, and to the want of proper precaution on the part of contestants or their attorneys. In speaking of patent suits, the late Judge Grier said, "The trouble is that lawyers do not understand mechanics, and mechanics do not understand law." While there are to-day able patent lawyers with a knowledge of mechanics, and accomplished mechanics who are better versed in patent law than many lawyers who have devoted some attention to the subject, it cannot be doubted that much reckless waste of money in patent litigation is still due to the trouble referred to by Judge Grier.

Lawyers who are not familiar with the useful arts, have but little technical knowledge, and do not understand what authorities to refer to for information, or who have not been trained to the ready understanding of mechanical illustrations, are not in good condition for conducting patent cases. Even if they have a general understanding of the principles of patent law, they must look for the assistance of some one who is practically familiar with the art to which the controversy relates, to make the proper searches. The result of this divided duty is increased expense and unnecessary publicity of the strong and weak points of a plaintiff's or defendant's case.

The lawyer who volunteers to take charge of a patent case before the courts without the proper training, qualifications and facilities for performing his duties

properly, is on a par with the mechanic of education too limited to enable him to understand law, who undertakes to help inventors before the Patent Office.

To properly conduct patent suits, there must be the application of both legal and technical knowledge; and if there was a little more of the latter at the commencement of litigation, there might be fewer disappointments and less waste of money.

OUR U. S. COURT PRACTICE.



WHEN a patentee whose patent has been infringed on, or a defendant against whom a bill of complaint has been filed, seeks for advice at these offices, the first proceeding is for both members of the firm to carefully examine the patent involved. If the case, upon this examination, appears such that the party seeking advice can be justly advised to incur any expense whatever in the pending or threatened litigation, a retaining fee will be required prior to further consultation and investigation.

The amount of a retainer varies, according to the nature of the invention to which the prospective litigation may relate.

Should a plaintiff who seeks our services be a patentee who has secured his patent through these offices, or a firm for whom we have conducted and continue to conduct business, and with whose patent matters we are consequently familiar, the retainer will be light.

It is impossible to state in advance what the cost of

a patent suit will be ; but in all cases an estimate can be given of special or *per diem* services ; but there are many incidental expenses, such as the charges of the officers before whom the testimony is taken, traveling expenses, printing, etc., for which no estimate can be given in advance.

The library attached to these offices is an important aid to us in making, promptly, investigations which could otherwise only be made by a tedious examination of the books of different public libraries during restricted hours.

We are prepared to furnish applicants with pamphlets relating to contested cases conducted by us before the United States Courts and the Patent Office.

INTERFERENCES.



INTERFERENCES are proceedings instituted for the purpose of determining the question of priority of invention between two or more parties claiming the same patentable invention.

The rules regarding the conduct of interference cases are of such a character, and the appeals so numerous, that they cannot be prosecuted without much sacrifice of time and money.

There are other reasons why every proper effort should be made to dispose of an interference without entering upon costly and tedious litigation. In the first place, a controversy begun by an interference in the Patent Office may afterwards be continued in the courts ;

but the greatest objection to interferences, necessary as they are to decide questions of priority arising in the Patent Office, is the premature publicity which they tend to give to unprotected inventions.

As soon as the final interference is declared, the papers of the application on file are open for examination by the contestants and their attorneys, and as soon as the examination of witnesses commences, the inventions are exposed, and become the subject of gossip. The importance which litigation imparts to inventions may tempt the cupidity of copyists and adapters, who, obtaining a knowledge of the points in controversy, may set their small brains to work, and contrive, by means of so-called changes or improvements, to appropriate that or part of that for which the contestants are fighting; or may manage at least to insinuate themselves, for their own purposes, into the controversy.

It is not an unfrequent occurrence for the successful contestant, after months of litigation, to find that he has, by the necessary exposure of his invention, created an array of antagonists which he may not be able to dispose of without further litigation, either in the Patent Office or before the courts.

Interferences are necessary evils, and must be met by precautions, which we will now explain, and which we invariably adopt, our remarks applying in the first instance to those interferences (the most common) which are declared between two pending applications.

As soon as the preliminary interference has been declared between the application of a client and another application, we immediately procure copies of the papers

filed in the Patent Office by the opposing party, to determine whether there is in fact any interference between the inventions.

An examiner may conclude that there is a conflict where really none exists, and if the office can be convinced of the mistake, there is an end to the interference; or it may be shown, after careful investigation of the state of the art, that neither party is entitled to what he claims, or that the history of prior inventions is such that both parties can obtain patents with modified claims, or, that the feature involved in the interference represents but a trifling portion of our client's invention, and that he may abandon this feature without material injury to himself, the interference being thus avoided.

In other cases, the opposing party may be induced to yield to some extent, with the same result.

When the inventions described in interfering applications are the same, and the claims substantially the same, it becomes a question whether it is best to settle all differences by a combination of interests. This has frequently been brought about by the good judgment of attorneys and a little forbearance on the part of contestants. Some of the most valuable patent properties are founded on the coalition of inventors who have been brought into conflict by the declaration of an interference, but who have settled their difficulties and united in turning their joint ingenuity to profitable account, instead of spending money in a controversy, and at the same time exposing their unpatented inventions.

There are, of course, many cases in which any amicable arrangements between contestants is out of the ques-

tion, and then it becomes the duty of the attorney to prosecute his client's case with all possible urgency, but in such cases it is his duty first to satisfy himself and his client, by preliminary investigations, that the latter has something to fight for.

The instances in which large sums of money have been expended in prosecuting interferences only to find that neither party was entitled to the thing claimed, are far from uncommon, nor is it a rare thing for contestants to settle their differences before the end of a hotly contested interference case.

After the declaration of a preliminary interference each party thereto, if he conclude to contest the matter, must file in the Patent Office a preliminary statement under oath, "showing the date of the original conception, the date that the invention was reduced to model or drawings, the date of its completion, and the extent of use."

These papers, to which the contestants cannot have access until the final interference is declared by the proper officer, are opened by the latter at a time appointed; if they show that one of the parties cannot date his invention back of the time when the other party made his application, priority will be awarded to the earliest applicant; but if no such state of affairs is exhibited by the papers, a final interference will be declared, the subject of controversy properly defined, and the contest will begin in earnest, the final decision being based on testimony taken in much the same manner as in equity cases before the United States Courts, a certain time being allotted to each party within which to take his proofs, and

a day being set for a hearing of the case by the Examiner of interferences.

From the decision of the interference Examiner, an appeal may be taken to the Board of Examiners-in-chief upon payment of a Government fee of \$10; and from their decision an appeal lies to the Commissioner of patents in person, the Government fee being \$20.

If the party against whom the Commissioner decides be an applicant, and be dissatisfied and able and willing to continue the contest, or rather begin it anew, Section 4915, Revised Statutes, it seems, will enable him to gratify his wish. This section, which we have had occasion to mention before, enables him to file a bill in equity in one of the Circuit Courts of the United States, and thereupon to have the case tried and decided anew; and whether successful or not in this proceeding, he will have the privilege of paying all the expenses of it.

The testimony in interference cases and the briefs of counsel must be printed, unless, for reasons satisfactory to the Commissioner, the printing be dispensed with. To print is the rule.

There is a class of interference cases in which an applicant whose case has been rejected on reference to an existing patent thinks he can date his invention back of that of the patentee, and accordingly demands the declaration of an interference.

The applicant knows the date of the patentee's application, but it is not until he has access to the patentee's preliminary statement after the declaration of the final interference that he knows how far back the patentee dates his invention. The applicant after perusing this

statement may conclude that it is useless to continue the controversy, or the statement may be such as to convince him that he is prior in date to the patentee, when the interference will proceed.

When one contestant charges another with piracy, there is little or no hope of any settlement, the contest must go on; and unhappily contests in such cases are always virulent, tedious and costly.

The records of the Patent Office show that the stealing of inventions is far too common, that confiding inventors are not unfrequently deceived by their supposed friends, who hurry to the Patent Office with stolen inventions, and secure patents in advance of the actual inventors; hence the propriety of giving the latter an opportunity of recovering their stolen ideas. But like all good laws this relating to the declaration of an interference between an applicant and a patentee has been abused. It has been used as a means of harassing patentees by trumped-up charges, with the view of driving them into the making of bargains with the assailants, or in order to make capital before the courts.

The only remedy against these mischiefs would appear to be a law placing a patent beyond reach of interference in the Patent Office after it is more than two years old—questions relating to the patentee's rights after the lapse of two years being left entirely with the courts.

If in an interference between an application and a prior patent, "priority" is awarded to the applicant, the Commissioner cannot annul or vacate the prior patent, he can only grant another patent to the applicant, so that there shall be two adverse patents extant for the same

thing. For this state of affairs or for the case in which by mistake two such patents have been granted, the law has considerably made special provision for settling the matter by litigation in the courts.

Section 4918, Revised Statutes, provides that whenever there are two interfering patents, any party interested in any one of them may have relief against the interfering patentee, and all parties interested under him, by suit in equity against the owners of the interfering patent; and the court may, upon due proceedings had, adjudge and declare *either* of the patents void in whole or in part, or invalid in any part of the United States, according to the interest of the parties.

It will be noticed that this, while enabling the party who has been successful in a Patent Office interference, to perhaps obtain, by proving his better right over again, a really effective judgment, which shall take from his opponent the ostensible title to which he has been twice decided to have no right;—also gives that opponent a second chance. The Court may adjudge *either* of the interfering patents to be bad in whole or in part.

We have said enough about interferences to show that they are controversies to be avoided if possible.

We shall be glad to furnish clients with pamphlets relating to interferences conducted at these offices; they are cases on the management of which we can bring an experience of more than twenty years to bear; indeed, during that time, this office has always had charge of one or more of these cases.

As regards the fees charged for these cases, they are somewhat less than in cases before the courts. It is

impossible to tell in advance what the cost of conducting an interference case will be, we can only state in advance our *per diem* charges.

In concluding this portion of our pamphlet, we may say that we are always ready to prepare agreements and other legal documents, to give opinions based on searches, referred to in another portion of the pamphlet, our main aim throughout being to offer to our clients the advantage of finding in the one establishment the varied technical and professional assistance which they may need in business connected with patents.





FOREIGN
DEPARTMENT
OF
HOWSONS'
PATENT OFFICES,



119 South 4th Street,
PHILADELPHIA.



FOREIGN DEPARTMENT.



WHILE the manufacturing countries of Europe afford profitable fields for the working of really useful inventions, great caution should be exercised by American inventors in securing foreign Patents.

It must be remembered, however, that, with the exception of Germany, Russia and Canada, no patent-granting country in Europe has adopted a system of examinations like our own, patents being simply granted without any material criticism of the papers presented. As the patent laws of foreign countries do not provide for the repairing of patents by reissues, it will be seen that great reliance must be placed on the character and qualifications of the foreign agents, in order that justice to the patentee may be assured.

As in this country, the value of a patent in European states is in a great measure estimated by the standing of the agent through whom it was procured.

In England, for instance, the first question asked by the intended purchaser of a patent is "Who prepared the papers?"

Care should be taken first that the papers be sent from this country in such shape as to secure the best possible patents; and, secondly, that experienced agents of reliability and good standing be employed abroad to obtain the patents.

In regard to the preparation of the necessary papers, it may be remarked that there are many popular errors as to the requirements of the different countries wherein

patents are sought. As an instance of these errors may be cited the general delusion, not confined to inventors, but entertained by too many agents in this country, that in applying for British patents it is merely necessary for the inventor, or his agent, to send abroad a copy of the papers prepared for the American patent. The possible evil results of such a course will be understood when it is borne in mind that the specifications of English and other foreign patents are, or should be, very different documents from those required in this country; and that an invention with a variety of modifications, which would require separate United States patents, can be included in one English patent, if the title and specifications be carefully prepared by one experienced in such matters.

Since the establishment of these offices, twenty-six years ago, we have invariably adhered to the rule of employing none but gentlemen of the highest professional standing to represent us abroad, preferring to pay the fees which the value of their services can command, rather than to run such risks as are foreshadowed in the lower charges of men of lower standing.

The procuring of foreign patents has long been a leading branch of our business, and one for the prosecution of which we may fairly claim to have peculiar advantages. The extent of this branch of our business has been for several years second to none in this country; and as our senior partner has himself practiced as a patent solicitor abroad, inventors may be satisfied that their foreign papers will be well prepared.

Inventors desirous of procuring foreign patents are cautioned to take the necessary preliminary steps before

the issue of their United States patents, since in most foreign countries valid patents cannot be granted for inventions which have been published in such countries prior to the application for a patent there. The Official Gazette of the United States Patent Office is sent abroad immediately on the issue of the United States patent; and this in many cases is considered sufficient publication to bar the grant of a valid patent. Furthermore, when a patent is issued here, any one can obtain a printed copy, which can be sent at once to a foreign country and patented there, in violation of the rights of the true inventor.

The best and, in fact, the only remedy which the American inventor has against such a fraudulent act, is to have the papers prepared and sent abroad before the publication of the invention in this country.

In the following pages will be found particulars relating to patents in different countries, with estimate of the cost in United States currency. These particulars are necessarily brief, but will suffice to point out the leading features of the laws of different countries.

SYSTEM OF CHARGES.

It should be understood that the estimates given relate to ordinary cases and signify the cost in United States Currency, and that they include all Government fees, and agency fees, both here and abroad, as well as the cost of specifications, drawings, and everything necessary to complete the application. When patents for the same invention are taken out in several countries at the same time, a reduction may be made. We make a reduc-

tion also in cases where no drawings are required; but where the drawings and specifications are very elaborate, the fees may be increased to a limited extent.



CANADA.

The total cost of obtaining a Canadian patent through our agency is \$65, including the Government fee; such patent being for a term of five years. This term, however, can be extended to ten years by the payment of \$20 Government fee; and may be further extended to the full term of fifteen years by an additional payment of \$20. But in any case the patent cannot extend beyond the term of the prior foreign patent, if any has been granted, for the same invention.

A model is required in every case which can be represented by a model.

NOTE.—No valid patent can be obtained in Canada for an invention which has already been patented in any foreign country for more than one year.

The patented article or machine cannot be imported into Canada after the expiration of twelve months from the date of the patent.

It has been recently decided that the invention need not be worked in Canada within the two years, but that, at the expiry of two years, any citizen of the Dominion

has a right to exact from the patentee a license to use the invention patented, by applying to the owner, and on payment of a fair royalty.



GREAT BRITAIN.

British Letters Patent cover England, Wales, Scotland, Ireland, and the Channel Islands, but not the Colonies, most of which grant separate patents under laws of their own.

TERM OF PATENT.—Maximum, fourteen years; but if the invention has been previously patented in other countries, the British patent will not be valid after the expiration of any such previous foreign patent.

COST, from \$280 to \$310, payable in advance; or, if preferred, \$120 may be paid in advance, and the balance within three months.

NOTE.—(1.) Payment of the entire fees at once secures greater expedition in the completion of the patent,—an important point, since it would appear from recent rulings that in the case of conflicting claims, priority in law will be adjudged to the patentee who first secures the seal.

(2.) A stamp duty of £50 is payable before the end of the third year of the patent, and a further duty of £100 before the end of the seventh year. If either of these

duties be not paid in time, the patent is irrevocably lost.

(3.) It is not necessary that the patentee should be the original inventor, and neither power of attorney nor model is required. The patent is granted without examination as to the novelty of the invention, but the British patent will be invalid if the invention has been previously shown or described in any printed publication within the kingdom.

(See preface to "Foreign Department" as to publication of United States patents abroad, page 90.)

USEFUL DESIGNS.—Articles having some peculiar shape or design which renders them "useful" can be registered under the "Useful Designs Act" for a term of three years, at a cost of from \$85 to \$100.

ORNAMENTAL DESIGNS can be registered at a cost and for terms varying with the class of goods to which the design is applied.



FRANCE.

TERM OF PATENT.—Maximum, fifteen years ; but can in no case extend beyond the term of an original foreign patent for the same invention.

COST—including Government tax for first year, \$100.

NOTE.—(1.) An annual tax of about \$25 must be paid.

(2.) The invention must be worked in France within two years from the date of the delivery of the patent, and operation must not afterwards be discontinued for two successive years. The patented articles cannot be imported.

(3.) To effect a registered assignment of a patent, the entire tax for the remainder of the years during which the patent has to run at the time of the transfer must be paid into the Treasury.

A French patent is granted without examination, and without guarantee of the Government. Power of attorney to the agent is required, but models are dispensed with. A previous publication of the invention in any country renders a French patent invalid.



BELGIUM.

TERM OF PATENT.—Maximum, twenty years ; but in case the invention has been previously patented elsewhere, the Belgian patent will expire at the same time as the original foreign patent.

COST—including Government tax for the first year, \$75.

NOTE.—(1.) Annual tax to be paid, amounting for the second year to about \$6, and increasing annually, thereafter, at the rate of about \$2 per annum to the end of the term.

(2.) The invention must be worked in Belgium within one year after putting it into operation abroad.

(3.) The Belgian patent, as in most of the other foreign countries, may be taken out by the inventor or his assignee, from whom a power of attorney to the agent is required. No model is necessary. No official examination by the authorities is made. But if the invention has been previously worked in Belgium by parties independently of the inventor, or has been previously published (except in a Government publication), the Belgian patent will be invalid.



GERMANY.

Under the Imperial Act of July, 1877, a German patent extends to all the States of the German Empire, including:

1. Prussia.
2. Bavaria.
3. Baden.
4. Saxony.
5. Wurtemberg, etc.

TERM OF PATENT.—Maximum, fifteen years.

COST—\$100, including the first year's tax.

In case of refusal of application by the Examiner, there will be an additional charge of \$25 for appeal.

NOTE.—(1.) An annual tax must be paid, amounting for the second year to £3, for the third of £5, and increasing at the rate of £2 10s. per annum.

(2.) The patent may be withdrawn by the Government after three years, if the invention has not been carried into operation, or if the necessary steps to that end have not been taken, or if the patentee refuses a license when a fair royalty is offered, and it is for the public good to grant such license.

(3.) Power of attorney from the inventor or the owner of the invention is required, but models are not necessary, except in fire-arm cases. A valid German patent cannot be obtained for an invention which has been previously published there or elsewhere. Hence German patents should be applied for before the United States patent for the same invention is granted, and therefore the papers should be sent abroad at least two weeks before the final Government fee is paid here.

We have grouped Canada, England, France, Belgium, and Germany together as the foreign countries in which, as a rule, patent property is most available and valuable. The last four being contiguous manufacturing countries, a patent in one of them is likely to be made more valuable by patents in the others, while the Canadian patent is a valuable auxiliary to an United States patent.

There are numerous inventions which are of such general utility, or which are specially adapted to the wants or capacities of some of the countries hereinafter named, that such inventions, if patented in these countries, might become sources of profit to the inventors.

**AUSTRIA AND HUNGARY.**

TERM OF PATENT.—Maximum, fifteen years ; but in no case longer than a previous foreign patent for the same invention. One application suffices for both countries, but a separate patent for Hungary is granted with that for Austria, and without any additional expense.

It is usual to apply for a term of one year, with the privilege of prolongation from year to year.

COST—including Government tax for one year, \$100.

NOTE.—(1.) To maintain the patent from year to year, Government and municipal taxes must be paid, amounting for the first five years to about \$18 per year, and increasing from the fifth to the tenth year at the rate of about \$5 per year, and after the tenth year, at the rate of about \$8 per year.

(2.) The invention must be operated in Austria within one year from the delivery of the patent, and the operation must not cease for two consecutive years. Actual working of the invention during the first year must be proved to an official commission. Prior publication in Austria, or prior working there, is a bar to a valid patent.

(3.) In Austria, and in each of the continental countries hereinafter named, no models are required, but in each case a legalized power of attorney from the inventor or his assignee, to the agent, is necessary.



ITALY.

TERM OF PATENT.—Maximum, fifteen years, but not longer than the term of a previous foreign patent.

COST.—According to term asked for. For six-year term, including annual tax for first year, \$125 to \$135.

NOTE.—(1.) Annual tax to be paid, amounting for second and third years to about \$15; from fourth to sixth years, \$20; from seventh to ninth, \$25; tenth to twelfth, \$30; thirteenth to fifteenth, \$35; in addition to which there is a small tax for each extension of term asked for.

(2.) Invention must be worked in Italy within one year, if the patent be for less than six; but if the patent be for six years or over, two years are allowed for operation.



SPAIN.

INCLUDING CUBA AND OTHER COLONIES.

NEW LAW OF AUGUST, 1878.

TERM OF PATENT.—Twenty years, if the invention has not been previously published or patented anywhere.

Ten years if it has been patented elsewhere within two years preceding the application in Spain. Five years if patented elsewhere more than two years previously.

COST.—\$100.

NOTE.—Invention to be worked in Spain within two years, and operation must be certified, and the working must not cease for more than a year and a day during the term of the patent. There is an annual tax of twenty francs for the second year, and increasing at the rate of ten francs each year.



RUSSIA.

TERM OF PATENT.—For three, five, or ten years, without privilege of extension. The application is subject to official examination; but the patent, if granted, is not guaranteed by the Government. Prior application or use of the invention in Russia is a bar to a valid patent.

COST.—\$550 for ten years.

NOTE.—The invention must be worked in Russia within the first quarter of the duration of the privilege dating from the day of delivery. Operation to be certified. A single operation is sufficient.

The patented article can be imported to Russia for the purpose of working the invention there.

**NORWAY AND SWEDEN.****NORWAY.**

TERM OF PATENT.—Ten years or under, as fixed by Government. Such term can in no case extend beyond the date at which the previous foreign patent shall expire.

COST.—\$150.

NOTE.—Invention must be worked within two years from the date of the grant of the patent.

SWEDEN.

TERM OF PATENT.—From three to fifteen years, as fixed by Government, usually from five to ten years. Such term can in no case extend beyond the date at which the previous foreign patent shall expire.

COST.—About \$100.

NOTE.—A valid patent can be obtained only by the inventor. Applications for patents are examined by a Board of Trade as to the merits of the inventions, but not as to their novelty.

The invention must be worked within two years from the date of the patent, and the operation must be certified and proof of the operation renewed yearly during the continuance of the patent.

**DENMARK.**

TERM OF PATENT.—Three to fifteen years, but to foreigners seldom, if ever, for more than five years.

COST.—\$100.

NOTE.—Invention must be operated in Denmark within one year, and operation must not afterwards be discontinued.

**PORTUGAL.**

TERM OF PATENT.—Maximum fifteen years, but not beyond the term of previous foreign patent. No extension granted.

COST.—About \$520.

NOTE.—The invention must be put in operation in Portugal within the first half of the term of the patent.

SWITZERLAND.

No patents granted except in one canton (Tessin), where the local government has the power of granting the exclusive privilege of working a patent within its territory.

**BRAZIL.**

TERM OF PATENT.—The duration of the patent is fixed by the Government, and varies from five to twenty years.

COST.—About \$350.

NOTE.—A patent becomes void (1) if not worked within two years from the delivery of the patent ; (2) if the invention be proved to be old.

OTHER AMERICAN STATES.

Patents can also be obtained in other South American and Central American States,—Peru, New Granada, Paraguay, Argentine Republic, Colombia, Venezuela, Guatemala, Nicaragua, San Salvador, and Costo Rica.

COST.—About \$300 for each country.

BRITISH COLONIES.

The colonies of India, Ceylon, New Zealand, New South Wales, South Australia, Queensland, Tasmania, Victoria, Cape of Good Hope, British Guiana, Jamaica, Trinidad, and British Honduras, grant patents under their own laws to foreigners as well as residents.

COST.—About \$300 for each colony.

Any further information in regard to foreign patents may be obtained on application at our offices.

**PUBLICATIONS
OF HOWSON & SONS,**

CERTIFICATES,

REFERENCES.

HOWSONS' PATENT OFFICES,

119 SOUTH FOURTH STREET,
PHILADELPHIA.

HOWSON & SONS' PUBLICATIONS.

(1.) A Brief Treatise on Patents for Inventors and Patentees. By H. and C. Howson. Published by Porter & Coates, Philadelphia. Price, \$1.

"I have not seen anywhere more information relating to patents, or more correct information in such compact form."

HON. ELLIS SPEAR,
Acting Commissioner of Patents.

"It can be unqualifiedly commended as a correct and trustworthy guide."

HON. FURMAN SHEPPARD.

"Your book far excels all manuals on this subject."

DR. ED. H. KNIGHT,
Knigh's Mechanical Dictionary.

"It is just the kind of book which I have told you was wanted, and frequently urged you to prepare."

HON. J. M. THACHER,
Late Commissioner of Patents.

"A little book which supplies a popular and legal want."

Journal of the Franklin Institute.

"This book of 160 pages contains more information of value to patentees than any work of its size that has come to our knowledge."

Scientific American.

(2.) Our Country's Debt to Patents. By H. Howson. Published by the United States Patent Association.

"An essay by H. Howson, Esq., the well-known Patent Solicitor of this city. He makes very happy illustrations of the far-reaching effect of our patent system on inventions."

Philadelphia Ledger.

(3.) Patents and the Useful Arts. By H. Howson.

"An instructive little volume."

Henry C. Carey.

"There is a great deal of curious information in the book which will be found more interesting than the title promises."

St. Louis Republican.

"The subject has been so treated as to make it a book both interesting and instructive."

Philadelphia Ledger.

(4.) A Brief Inquiry into the Principles, Effects, and Present State of the American Patent System. By H. and C. Howson. (Fourth edition.)

(5.) Third edition, revised and abridged especially for use at the International Patent Congress at Vienna, by the request of the Hon. J. M. Thacher, Assistant Commissioner of Patents, and representative of the United States in the said Congress.

(6.) The same work in the German language.

(7.) Answers of Howson & Son to Questions of the State Department of the United States relative to Patents.

(8.) The Keely motor criticised by H. Howson.

(9.) Reasons for Dispensing with Models in the Patent Office. By H. Howson.

(10.) Catalogue of Reference Library attached to Howson's Patent Offices.

H. HOWSON, Sr.
ON
REISSUED PATENTS.

Comments on the Decision of the United States Supreme Court in the Case of Mills vs. The Bridgeport Brass Company. Practical Effects of the Decision, and its Warning to Inventors.

T. & J. W. JOHNSON & CO., Publishers,
535 Chestnut St., Philadelphia.

From the North American and U. S. Gazette, May 9, 1882.

Mr. Howson's book is one that should be in the hands of every inventor and patentee, and, indeed, of all those who are in any way interested in the subject matter. Mr. Howson exposes the practices of sharpers and petti-foggers, and shows how patentees and the public are deceived.

The treatise is of great practical value.

From the American Law Review, Boston, August, 1882.

The author of this book, the title of which indicates its scope and object, is a well-known and experienced Patent solicitor.

The book calls renewed attention to the fact that many valuable inventions are sacrificed through the incompetency and dishonesty of patent solicitors, and warns inventors to be more careful in their selection of those whom they employ for the difficult and delicate work of preparing their application, and carrying them through the Patent Office.

Many, if not most, of the reissues that have been granted during the past forty years, have been sought for the purpose of correcting errors or insufficiencies in the original, that were due in a great part to carelessness, ignorance, and want of honesty on the part of the solicitor who prepared the original application.

As relief in such cases is no longer possible, defects of this sort will be hereafter incurable. Care in the selection of the solicitor is, therefore, even of greater consequence than before.

Many patent solicitors are untrustworthy; many have had no preliminary training. Many have no higher idea of their duty to their client than to make it their object to get for him a patent of some sort in the least possible time, instead of working to secure the full invention of the applicant, even if time and labor are required to satisfy the Patent Office as to the exact claim to which he is entitled. Many more have not the necessary ability. These men would soon find their level in any other profession, but by extensive advertising they are often able to get far more business than they deserve, and the loss to inventors and the community is proportionally great.

Mr. Howson's book will accomplish a very useful purpose if it reaches the portion of the community for whom it is intended, and induces meritorious inventors to require other assurances of a solicitor's capacity than his advertisements in country papers or his own story as to his influence in the Patent Office.

CERTIFICATES.

BURLINGTON, IOWA, *October 2, 1857.*

DEAR SIR:—I take this occasion to state to you that for several years past I have been acquainted with the manner in which you have conducted your business as a patent solicitor.

This has always been highly creditable to yourself and satisfactory to the Patent Office.

You understood your cases well, and presented them in that intelligible form which generally insured success. I forward this certificate, hoping that it may be serviceable to you in continuing to find that employment in your profession to which your intelligence, industry, and courteous bearing so justly entitle you.

Yours very truly,

CHARLES MASON,
Late Commissioner of Patents.

HENRY HOWSON, ESQ.

NATIONAL ASSOCIATION OF WOOL MANUFACTURERS.

No. 55 Summer Street,
BOSTON, MASS., *October 6, 1865.*

MY DEAR SIR:—It gives me great pleasure to give my testimony as to the manner in which you have conducted your business as a solicitor of patents, during the four years that I was chief clerk and executive officer of the United States Patent Office, and for a considerable period acting commissioner.

The papers presented by you, specifications, drawings, correspondence, etc., were invariably models of

neatness, accuracy, and legal precision. They were frequently pointed out to younger solicitors as among the best examples and precedents for practice in the Office. Your intercourse with the Office was so conducted that all the rights of your clients were secured without personal controversy. With the best opportunities for judging, I do not hesitate to say that your thorough knowledge of mechanics and patent law, places you in the first rank of solicitors of patents in the United States.

Very truly yours,

JOHN L. HAYES,

Late Chief Clerk and Executive Officer, U.S. Pat. Office.

H. HOWSON, ESQ., Phila., Pa.

WASHINGTON, D. C., *November 20, 1865.*

I fully and cheerfully endorse the statement made by Mr. Hayes in the above letter, and commend Mr. Howson to the patronage of the inventors of the country.

D. P. HOLLOWAY,

Late Commissioner of Patents.

CINCINNATI, *November 16, 1871.*

GENTLEMEN:—I take great pleasure in testifying to the ability and promptness with which you conducted your business before the Patent Office while I was commissioner. Your cases were thoroughly, accurately, and neatly prepared, well presented, and strongly urged. I wish you every success.

Very truly yours,

S. S. FISHER.

MESSRS. H. HOWSON & SON, Philadelphia, Pa.

NAVY DEPARTMENT, BUREAU OF STEAM ENGINEERING,
WASHINGTON, D. C., *Aug.* 29, 1874.

I have had the pleasure of knowing Mr. Henry Howson intimately for many years, during which he has on several occasions conducted patent business for me in an admirable manner.

His engineering education, his long experience as a patent solicitor, and the high estimation he bears as an expert, place him among the most prominent men of his profession.

I have very frequently recommended my friends who are interested in patent matters to engage the services of Mr. Howson, and the result has always been most satisfactory to them.

Mr. Howson's offices in Philadelphia and Washington are admirably organized, and every facility is afforded for transacting both the soliciting and legal branches of the profession,—the latter branch being in charge of Mr. Howson, Jr., who has gained a prominent position as a patent lawyer.

WM. W. W. WOOD,
Engineer-in-chief U. S. Navy.

WASHINGTON, D. C., *Nov.* 4, 1875.
MESSRS. HOWSON & SON.

GENTLEMEN:—I regard it as only an act of justice, to make it my first duty, after leaving the position of Commissioner of Patents, to most heartily commend the promptness, fidelity and ability with which you conducted your business before the office while I was commissioner.

The applications filed by you were among those I regarded as standards in form, style and precision of statement.

Yours, very truly,

M. D. LEGGETT,
Commissioner of Patents.

WASHINGTON, D. C., *Nov.* 1, 1878.

MESSRS. HOWSON & SON.

DEAR SIRS:—Upon leaving the office of Commissioner of Patents, I desire to express my appreciation of the manner in which you have conducted business before the office. While attending carefully and ably to the interests of your clients, you have facilitated the transaction of your business in the office by the skillful presentation of your cases and your uniform fairness and courtesy. The high character of all your work shows the advantage of an extensive knowledge of the arts, as well as of patent law, and the further advantage of a long and varied experience in all the branches of the business. The character of your work is, no doubt, aided, in accuracy and promptness, by the admirable organization of your office (the best I ever saw), and by your extensive and well-selected library, which must furnish at hand all possible information necessary to the business. It has always been a pleasure to me to transact business both with yourself and your assistants. In these days, when so many ignorant and unscrupulous men impose upon the office with their worthless and troublesome services, it is espe-

cially a gratification to have honest and competent men to deal with. I trust, therefore, for the good of the office, the benefit of the public, as well as for your own profit, that the number of your clients may never be less.

Yours, very truly,

ELLIS SPEAR,
Commissioner of Patents.

REFERENCES.

The following list contains the names of a few of the many clients for whom we have transacted Patent business. For many of those named in the list we have procured Foreign Patents, and for others we have also conducted suits before the Courts.

A

Atlantic Refining Co., Petroleum,	Philadelphia.
American B. H. Sewing Machine Co.,	"
Allentown Iron Co.,	Allentown, Pa.
American Meter Co.,	Philadelphia.
American Machine Co.,	"
American Dredging Co.,	"
Asbury, H. T., Enterprise Manufacturing Co.,	"
Adamson, C. B. & W. B.,	"
Albrecht, H., Machinist,	"
Ayres & Sons, Horse Clothing,	"
Archbold, Samuel, Mechanical Engineer,	"
Altemus, H. T. & Co., Book Binders,	"
Alberger, M. H., Telegraphy,	"
Applegate, S. S., Electric Alarms,	Camden, N. J.
Allen, S. T., Plows,	Philadelphia.
Atwater, R. M., Glass,	Millville, N. J.
Anderson, J. W., Carriage Hardware,	Lancaster, Pa.
Albert, C. F., Musical Instruments,	Philadelphia.

B

Brooks, David, Telegraphy,	Philadelphia.
Baldwin Locomotive Works,	"
Bement & Son, Industrial Works,	"
Bartol. B. H., Sugar,	"

Burgess, Hugh, American Wood Paper Co.,	Royer's Ford, Pa.
Baugh & Sons, Fertilizers,	Philadelphia.
Butterworth, H. W. & Sons, Drying Machines,	"
Bromley Bros., Carpets,	"
Button & Co., Hosiery,	Germantown, Pa.
Baeder, Adamson & Co., Glue, etc.,	Philadelphia.
Buford, B. D., Plows,	Rock Island, Ill.
Bonzano, A., Phoenix Iron Co.,	Phoenixville, Pa.
Bibb, B. C., Stove Works,	Baltimore.
Budd, J. & S. W., Locks,	Philadelphia.
Baker, J. G., Enterprise Manufacturing Co.,	"
Brick, S. R., Gas Works,	
Bate, W. T., Steam Boilers,	Conshocken, Pa.
Buntin, Geo., Car Seats,	Boston, Mass.
Backmire, Geo., Locks,	Philadelphia.
Bachelor Bros., Segars,	"
Benezet & Co., Springs,	"
Bullock, C. K., Mills,	"
Braun, J., Lawn Mowers,	"
Burr, W. H., Steam Boilers,	"
Boyd, Geo., Heaters,	"
Betts, F. L., Sheet Metal Goods,	"
Baxter, D. W. C., Baxter's Business Directory,	"
Burnham, G., Baldwin Locomotive Works,	"
Bancroft, J. W.,	"
Boyd, J. & T. A., Winding Machines,	Glasgow, Scotland.

C

Clarke, Reeves & Co., Bridges,	Philadelphia.
Coffin & Altemus, Dry Goods,	"
Cresson, Prof. C. M., Chemist,	"
Carpenter, A. E. (Houghton & Co.),	"
Continous Draw Bar Co.	"
Cooper, Jno. H., People's Works,	"

Cooper, Jones & Cadbury, Brass Works,	Philadelphia.
Carrow, Bishop & Co., Jewelers,	Philadelphia and New York.
Comly, Joshua, Street Cars,	Philadelphia.
Cooper, W. S., Machinist,	"
Cunningham, R. B., Wagons.	Allentown, Pa.
Cottingham, J. C., Ship Chandler,	Philadelphia.
Cone, J., (Steamer Columbia),	"
Custer, Christian, Mills,	"
Campbell & Richards, Machinists,	"
Clinton, E., Brushes,	"

D

Disston, Henry, & Sons, Saws, Tools, etc.,	Philadelphia.
Dolan, Thos. & Co., Textile Goods,	"
Dougherty, Jas., Engineer and Machinist,	"
Drown, W. A., & Co., Umbrellas,	"
Dieterich, D. P., Rubber Goods,	"
Diamond Drill Co.,	Pottsville, Pa.
Dick, C. J. A., Phosphor Bronze Co.,	London.
Dietz, R. E., Sheet Metal Goods,	New York City.
Dupont, C. I.,	Wilmington, Del.
Denio, A. O., P. W. & B. R. R.,	" "
Dawson & Son, Washing Compounds,	Philadelphia.
Dyott, M. B., Lamps,	"
Daniels, H. H., Locks,	"
Davis, S. W., Machinist,	Wilmington, Del.
Dialogue, J. H., Iron Works,	Camden, N. J.
Dienelt & Eisenhardt, Textile Machinery,	Philadelphia.
Davis, H. C. & C. W., Furs,	"
Disston, T. S., Saws and Tools,	"
Disston, C., Trowels, etc.	"

E

Enterprise Manufacturing Co., Hardware,	Philadelphia.
Everest, H. B., Oils,	Rochester, N. Y.

Eaton & Ayer, Shuttles,	Nashua, N. H.
Ellis Keystone Agricultural Works,	Pottstown, Pa.
Everett, Horace, Sheet Metal Goods,	Philadelphia,
Eccles, J., Machinist,	"
Eddystone Manufacturing Co., Dry Goods,	"
Eagle Packing Co., Packing,	"
Evansville Furniture Co.,	Evansville, Ind.
Evans, T. R., Boots and Shoes,	Philadelphia.
Evans, S. W. & Co., Umbrella Mountings,	"
Evans, W. C., Printing Presses,	"
Evans, Howell, Printer,	"
Eshleman, J. A., Furnishing Goods,	"
Earle & Son., Fine Arts,	"
English, E. B., Lime,	"
Ellison, J. C., Looms,	"

F

Fritz, Jno., Bethlehem Iron Works,	Bethlehem, Pa.
Furbush & Son, Textile Machinery,	Philadelphia.
Fairbanks & Ewing, Scales,	"
Farmer, G. P., Buttons,	New York City.
Farrel, Franklin, Farrel Foundry,	Ansonia, Conn.
Flagg, Stanley G. & Co., Founders,	Philadelphia.
Fisher, H. H., Pipe Founder,	Allentown, Pa.
Frishmuth Bros., Tobacco,	Philadelphia.
Forbes, W. D., Mechanical Engineer,	Buffalo, N. Y.
Francis, C. S., Water Proof Goods,	Spring City, Pa.
Felton, Rau & Sibley, Paints,	Philadelphia.
Fuguet, H. T., Segars,	"
Follensbee, G. S., Pumps,	Lewiston, Maine.
Foreman, Jno., Bridges,	Pottstown, Pa.
Fitler, E. H., & Co., Cordage,	Philadelphia.
Farr, L. D., Oil Cloths,	"

G

Gray, H. W., Schomacker Piano Co.,	Philadelphia.
Griscom & Co., Millstone Dressing Machines,	Pottsville, Pa.
Griscom, Clement A., Peter Wright & Sons,	Philadelphia.
Griscom, W. W., Electrician,	"
Griffen, J., Phoenix Iron Co.,	Phoenixville, Pa.
Gerard, J., Trenton Lock Co.	Trenton, N. J.
Gillis & Gæghegan, Steam Fitters,	New York City.
Galloway, W., Pottery,	Philadelphia.
Gutekunst, F., Photographs,	"
Gregory, C. B., Smokeless Furnaces,	Beverly, N. J.
Golding & Co., Pottery,	Trenton, N. J.
Gorman, J. J., Contractor,	Philadelphia.
Goldsborough, J., Hand Stamps,	"
Greasley, E., Knitted Goods,	"
Gillinder & Bennett, Glass,	"
Gallagher, A. B. & Co., Distillers,	"
Goodyear, R. B., Looms,	"
Glanding, Jas., Packing,	"
Grove, W. H., Show Cases,	"

H

Horstmann & Co., Trimmings, etc.,	Philadelphia.
Harrison, Havemeyer & Co., Sugar,	"
Harrison Boiler Works,	"
Harris, Griffin & Co., Gas Meters,	"
Hoopers & Townsend, Bolts and Nuts,	"
Hein Coupling Co., Car Couplings,	Rock Island, Ill.
Hale & Kilburn Manufacturing Co., Furniture,	Philadelphia.
Harrison, A. C.,	"
Houghton, E. F. & Co., Cosmoline,	"
Hastings & Co., Gold Beaters,	"
Hussey, Wells & Co., Steel,	Pittsburgh, Pa.

Hall & Carpenter, Sheet Metal,	Philadelphia.
Hirsh Bros., Umbrellas,	"
Harper, J. H., Watches,	"
Harper, H. W., Slates,	Slatington, Pa.
Harvey & Ford, Turners,	Philadelphia.
Hart, Abram,	"
Hamilton, C. K., Paper Boxes,	"
Herzberg, A. & I., Jewellers,	"
Heald, A., Carpets,	"
Hill, Jas., Flour Mill,	Wilkesbarre, Pa.
Hien, P., Hien Coupling Co.,	Rock Island, Ill.
Hover, E. F., Inks,	Philadelphia.
Haskell Bros., Carriages,	"
Hub Clutch Co.,	"
Heckendorn & Wilhelm, Machinists,	Reading, Pa.
Henshall, Sam'l, Sewing Machines,	Philadelphia.
Harrison, W. H., Mechanical Engineer,	New Castle, Pa.
Hamilton, M. J., Steel,	Afton, Iowa.

J

Jones, E. H., Vulcan Iron Works,	Wilkesbarre, Pa.
Jones, Washington, I. P. Morris & Co.,	Philadelphia.
Jenkins, C. C., Governors,	"
Johnston, E. H., R. R. Frogs and Switches,	"
Jarvis Furnace Company, Furnaces,	Boston, Mass.

K

Knickerbocker Ice Co.,	Philadelphia.
Keystone Portable Forge Co.,	"
Kershaw, Thos., Carding Engines,	"
Kaye & Kaye, Locks,	Bradford, England.

I

Lobdell, G. G., Car Wheels,	Wilmington, Del.
Love, Jno. C., Sewing Machines,	Philadelphia.
Landenberger, Martin, Textile Goods,	"
Lauth, Bernard, Rolling Mills,	Howard, Pa.
Lauth, B. C., Rolling Mills,	Philadelphia.
Lucas, John, & Co., Paints,	"
Lowthorp, F. C., Civil Engineer,	Trenton, N. J.
Legrand, C. D., Wagons,	Wilkesbarre, Pa.
Lehman, B. E., Brass Goods,	Bethlehem, Pa.
Lukens, J., Alan Wood & Co.,	Conshohocken, Pa.
Luders, T. L., Phosphor Bronze Co.,	Philadelphia.
Lyons, C. W., E. F. Houghton & Co.,	"
Lever, J. S., Book Binder,	"
Lippincott, C. H., Soda Water Apparatus,	"
Leopoldt, C. F., Wire Cutters,	"
Leinbach & Wolle, Paper Bags,	Bethlehem, Pa.
Loeb & Schoenfeld, Laces, etc.,	Philadelphia.
Lane, A. T., Window Shades	"
Lloyd, Supplee & Walton, Hardware,	"
Lightfoot, B. H.,	"
Langham, T., Knitting Mills,	Elwood, N. J.

M

Middleton, N. & A., Car Springs,	Philadelphia.
Mc Callum, Crease & Sloan, Carpets,	"
Moore, Jas., Bush Hill Iron Works,	"
Mason & Co., Blacking,	"
Mellor & Rittenhouse, Manufacturing Chemists,	"
Mitchell, A., Supt. Lehigh Valley R. R.,	Wilkesbarre, Pa.
Merrick, J. V.,	Philadelphia.
Merrick, W. H.,	"
Meyer & Dickinson, Laces, etc.,	"

Michener, A. J.,	Watkins, N. Y.
Manhattan Packing Co.,	New York.
Miller Lock Co., Locks,	Philadelphia.
McArthur, J., Architect,	"
Miles, F. B., Machinist,	"
Moran, T., Artist,	Newark, N. J.
Miller, J., Michigan Central R. R.,	Detroit, Mich.
Mead & Graham, Engineers,	Middletown, N. Y.
Mills & Combs, Wagons,	Wilmington, Del.
Munro, Geo., Lasts,	Philadelphia.
Maule Bros., Lumber,	"
Murphy's Sons, Stationers,	"
Moss & Co., Stationers,	"
Mott, G. S., Telegraphy,	"
Mærtens, E., Scheppers Bros,	"
Morrison, G. W., Furnaces,	"
McFerran, J. A., Physician,—Pill Machinery,	"
Muhr's, H., Sons, Jewellers,	"

N

Nixon, Martin, Paper,	Philadelphia.
Noble, Chas. & Co., Stoves,	"
Norwalk Lock Co., Locks,	Norwalk, Conn.
National Sewing Machine Co., Limited,	Philadelphia.
Norris, Thaddeus,	"
Neafie & Levy, Ship and Engine Builders,	"
Nevegold, Scheide & Co., Rolling Mill,	Bristol, Pa.
Nittinger, A., Jr., Butchers' Tools,	Philadelphia.

O

Orr, Painter & Co., Stoves,	Reading, Pa.
Opdyke, S. B.,	Philadelphia.

P

Phœnix Iron Co.,	Phoenixville, Pa.
Pancoast & Maule, Pipe, etc.,	Philadelphia.
Pendleton, F. P., Jas. Smith & Co.,	"
Potts, Mrs. M. F., Sad Irons,	"
Phœnix Plate Co., Photograph Plates,	Worcester, Mass.
Phosphor Bronze Co.,	Philadelphia.
Pennock, Jos. L., Rolling Mills,	Coatesville, Pa.
Perry & Co., Stoves,	Albany, N. Y.
Poole, J. Morton, & Co., Chilled Rolls,	Wilmington, Del.
Philadelphia Burring Machine Co.	Philadelphia.
Parry, C. T., Baldwin Locomotive Works,	"
Pearce, G. D., Rock Drills,	"
Powell, J. G., Sewing Machine Attachments,	"
Powell, Thos., Burglar Alarms,	"
Powell, J. B., Spring Motors,	"
Pratt & Farmer, Buttons, etc.,	New York City.
Perot, T. Morris, Drugs,	Philadelphia.
Pleasanton, Gen. A. L.,	"
Philadelphia Lock Co., Locks,	"
Pott, J. L., Engineer,	Pottsville, Pa.
Packer & Sons, Machinists,	Philadelphia.
Packer, C. W., Ice Cream Freezers,	"
Parry, J. L., Mechanical Engineer,	"
Pike & Dean, Machinists,	"
Peberdy, G., Knitting,	"

R

Reyburn, Hunter & Co., Lightning Rods,	Philadelphia.
Reading Hardware Co., Hardware,	Reading, Pa.
Ridgway, Jacob E., Street Cars,	Philadelphia.
Riddle, S., & Sons, Textile Goods,	Glen Riddle, Pa.
Rice, J., Contractor,	Philadelphia.

Reeves, S. J., Phœnix Iron Co.,	Phœnixville, Pa.
Reh fuss, G. Sewing Machines,	Philadelphia.
Reynolds, Jesse, Heaters,	"
Read, G. W., Lumber,	New York City.
Reading Iron Works,	Reading, Pa.
Richards, C. B., Colt's Arms Co.,	New Haven, Conn.
Rohrmann, J. Hall, Sheet Metal Goods,	Philadelphia.
Rapp, B. R., Thill Couplings,	West Chester, Pa.
Rodgers, Prof. R. E.,	Philadelphia.
Rohrbacher & Horrman, Glass,	"
Rowland, W. & H., Iron and Steel,	"
Rumpp, C. F., Pocket Books,	"
Rankin, A., Locks,	"
Rinek, J., Cordage,	Easton, Pa.
Raymond & Campbell, Stoves,	Middletown, Pa.
Ringwalt, J. L., Editor,	Philadelphia.
Rue, Theodore, Stencils, etc.,	"
Roelofs, A., Shade Fixtures,	"

10

Smith, Jas., & Co., Cotton and Woolen Mill Supplies,	Philadelphia.
Sparks, T. W., Shot,	"
Schomacker Piano Co., Pianos,	"
Scovill Manufacturing Co.,	Bridgeport and New York City.
Sheppard, Hon. Furman,	Philadelphia.
Stuart, Peterson & Co., Stoves,	"
Sheppard, Isaac A., Stoves,	"
Shantz & Keely, Stoves,	Spring City, Pa.
Searle, J. Q. C., Stoves,	Cincinnati, O.
Spencer, Chas., Hosiery,	Philadelphia.
Schofield & Branson, Knitted Goods,	"
Stokes & Parrish, Hoisting Machines,	"
Sternberger, L., Shirts,	"
Steele & Condict, Engineers, etc.,	Jersey City, N. J.

Southern Machine Works,	Evansville, Ind.
Susemihl, F. C. L. G., Michigan C. R. R.,	Detroit, Mich.
Stubblebine, Wm., Bethlehem Iron Works,	Bethlehem, Pa.
Schaubel, H., Steam Boilers,	Philadelphia.
Smith, Orren M., Umbrella Runners, etc.,	"
Storer, G. W., Machinery,	"
Snediker, Jas. F., Machinist,	"
Schofield & Wilde, Woolen,	"
Sleeper, Wells & Aldrich, Canned Goods,	Burlington, N. J.
Scharff, A., Whips,	Philadelphia.
Struthers & Sons, Marble,	Philadelphia.
Stewart & Mattson, Locks, etc.,	"
Scheppers Bros., Woven Goods,	"
Sayre, J. W., Slates,	Martin's Creek, Pa.

E

Trautwine, J. C. T., Civil Engineer,	Philadelphia.
Tatham & Bro., Lead,	"
Trenton Lock Co., Locks and Hardware,	Trenton, N. J.
Thackara, Buck & Co., Gas Fixtures,	Philadelphia.
Taylor Co., N. & G., Tin Plate,	"
Thompson, Sir Wm., Electrician,	Glasgow, Scotland.
Tatham, H. B., Jr.,	Philadelphia.
Thorne, DeHaven & Co., Tools,	"
Travis, T. W., Iron Cross Ties,	"
Trøemner, H. W., Scales,	"
Tryon, E. K., Fire Arms,	"

U

Union Paper Collar Co.	New York City.
Upton, Wm., Jarvis Furnace Co.,	Boston, Mass.
Uhlinger, W. P., Machinist,	Philadelphia.



Vacuum Oil Co.,	Rochester, N. Y.
Vance, J. M., & Co., Hardware,	Philadelphia.



Wright, Peter, & Sons, Importers,	Philadelphia.
Wootten, J. E., Gen'l Manager Reading R. R. Co.,	"
Warden, Frew & Co., Oils,	"
Wharton, Wm., Switches, etc.,	"
Whitall, Tatum & Co., Glass,	"
Wood, Alan & Co., Iron,	Conshohocken, Pa.
Wheeler, Elbridge, Combined Iron and Steel,	Philadelphia.
Wright Bros., Umbrellas,	"
Wells & Hope Co., Metal Signs,	"
Warner & Co., Medicines,	"
Wilbraham Bros., Machinists,	"
Warren, Lober & Co., Roofing,	"
Wood, W. W. W., late Chief Engineer U. S. N.,	Washington, D. C.
Wallick, W., Mouldings,	Philadelphia.
Williams, Isaac. Hardware, Furnishing Goods,	"
Weston, T. A., Weston's Pully Blocks,	Stamford, Conn.
Wurflein, Wm., Fire Arms,	Philadelphia.
Wilson, T. A. & Co., Spectacles,	Reading, Pa.
Woodbury, J. A., Car Wheels,	Boston, Mass.
Wright Steam Engine Works,	Newburg, N. Y.
Ward, J. F., Civil Engineer,	Jersey City, N. J.
Wahl, Prof. W. H.,	Philadelphia.
Wenderoth, F. A., Photography,	"
Wilson, E. L., Photography,	"
Woodside, G. W., Printing,	"
Wood, H., Sup't Media R. R.,	Philadelphia.
Wiler, W., Stair Rods, Brass Work, etc.,	"
Warner, C. Y., Morocco,	Wilmington, Del.
Wellens, J. C., Embroidering Machines,	Philadelphia.

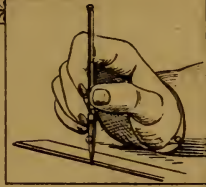

DRAWINGS

MADE AT

HOWSONS'

PATENT OFFICES

No. 119 SOUTH FOURTH ST.

PHILADELPHIA

NORRIS PETERS,
Photo-Lithographer,
458 Pennsylvania Avenue,
WASHINGTON, D. C.

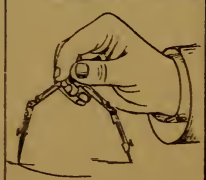

HENRY DISSTON & SON.—SAW HANDLE.

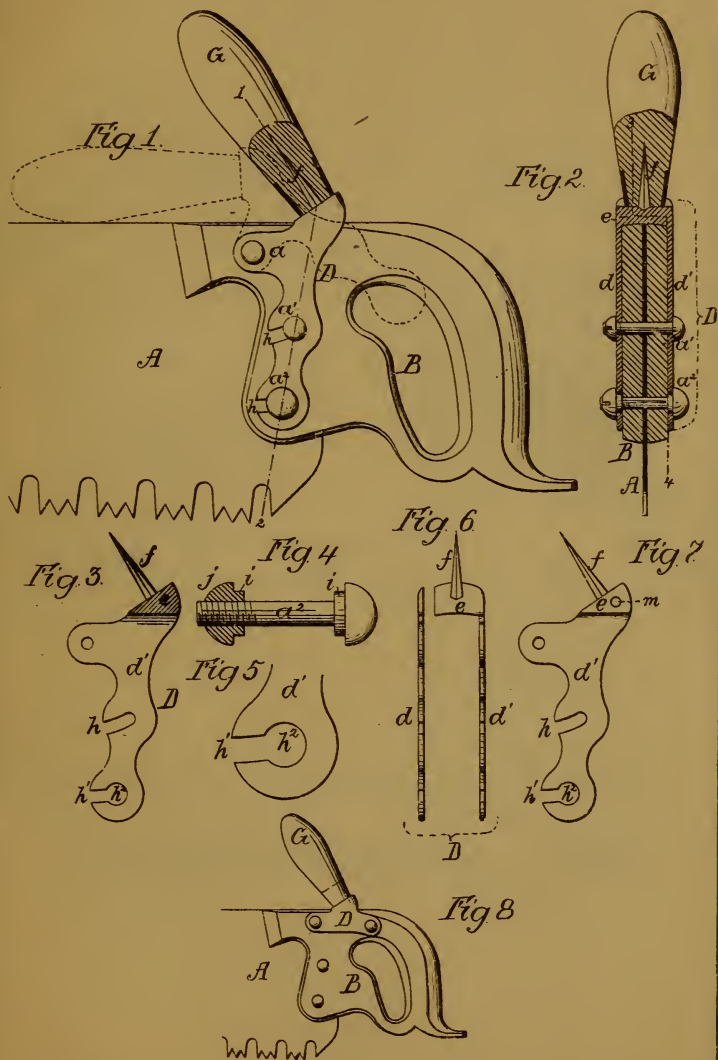

ALBERT.—PRACTICING VIOLIN.

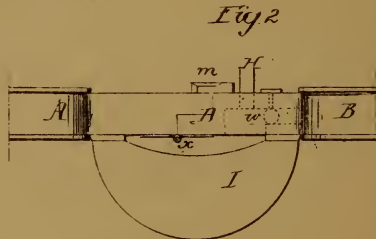
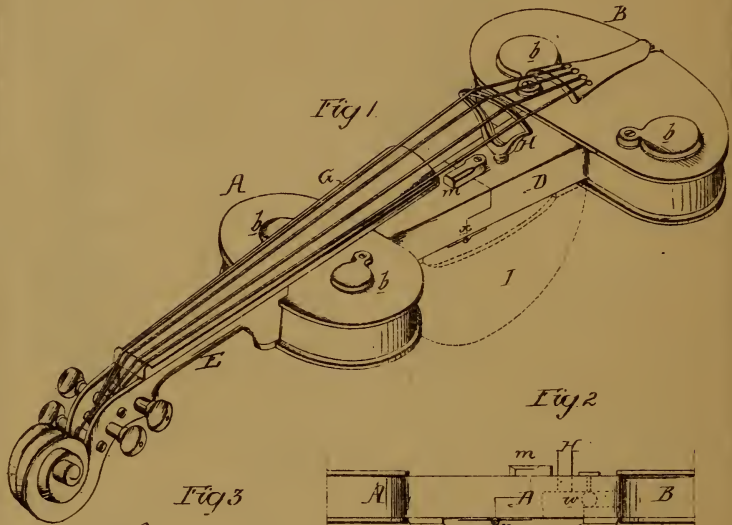
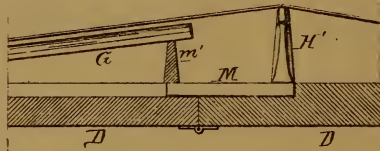

Fig 5



MEAD & GRAHAM.—STEAM BOILER.

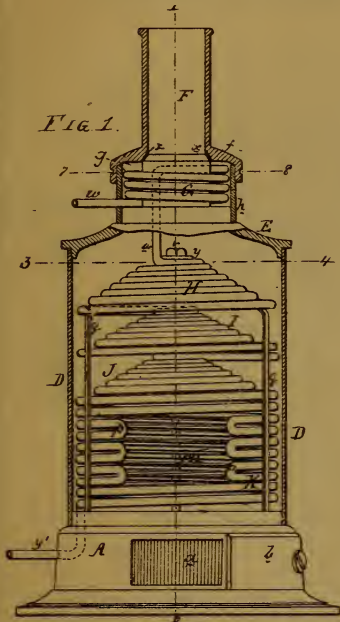

FIG. 1.

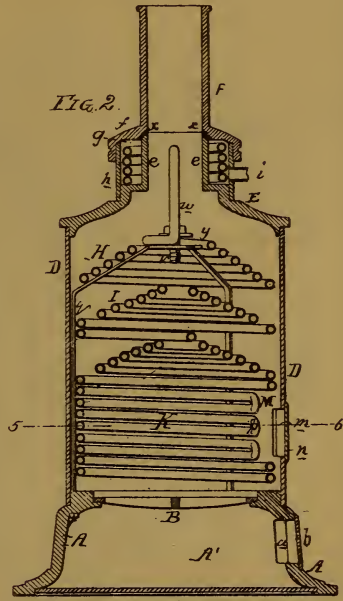

FIG. 2.

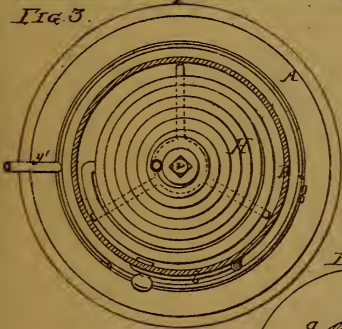

FIG. 3.

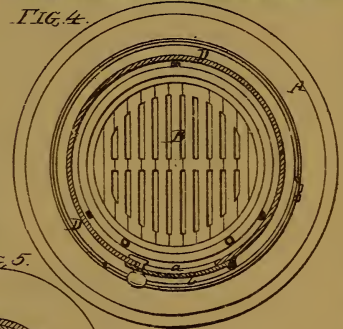

FIG. 4.

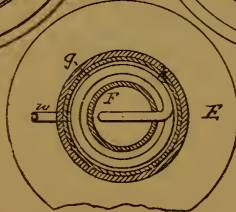
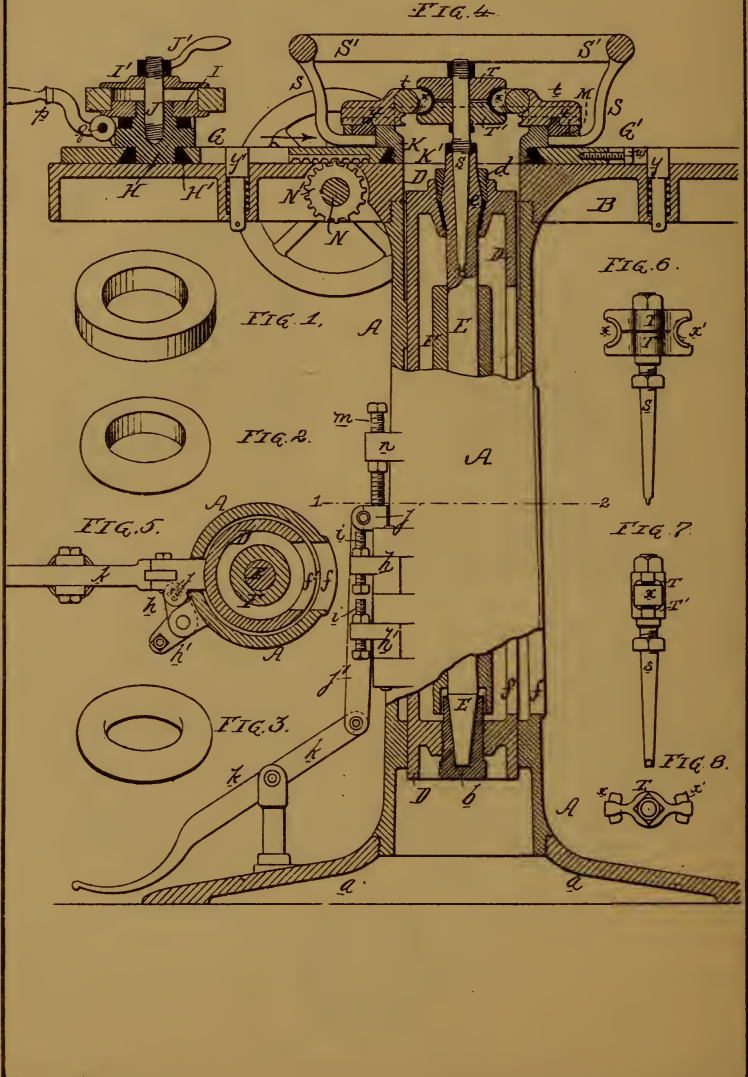

FIG. 5.

ENTERPRISE MFG. CO.
MACHINE FOR MAKING SAD-IRON HANDLES.



PHILADELPHIA BURRING MACHINE COMPANY.
WOOL-WASHER.

Fig. 1.

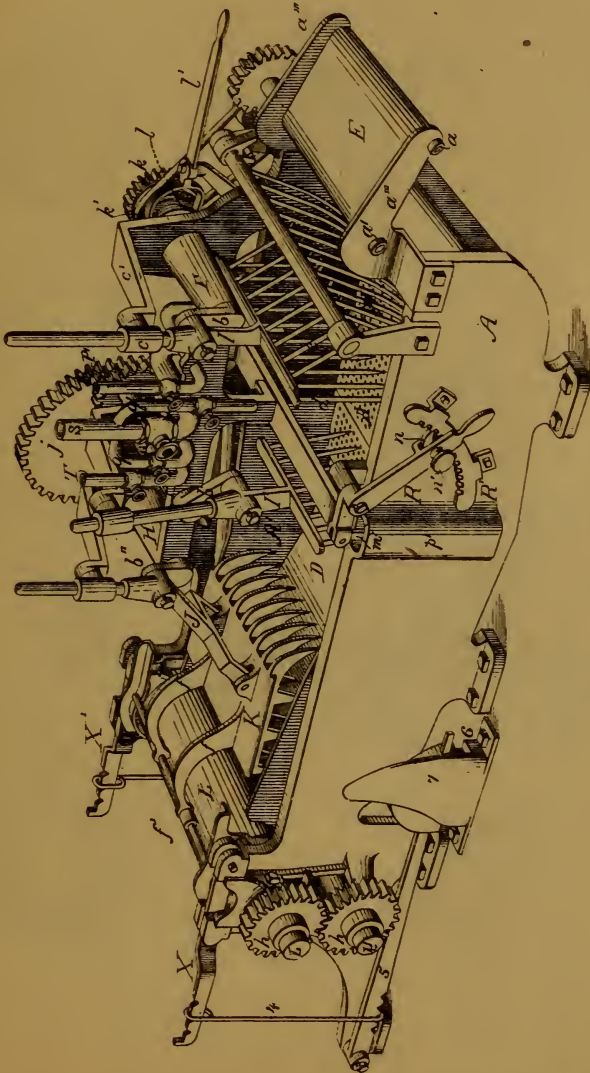

TRENTON LOCK CO.—MOUTH PIECE.

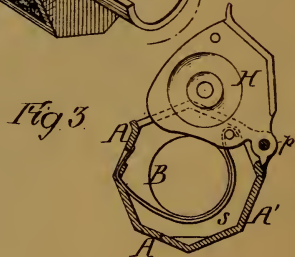
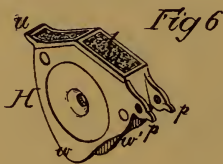
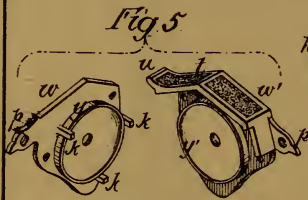
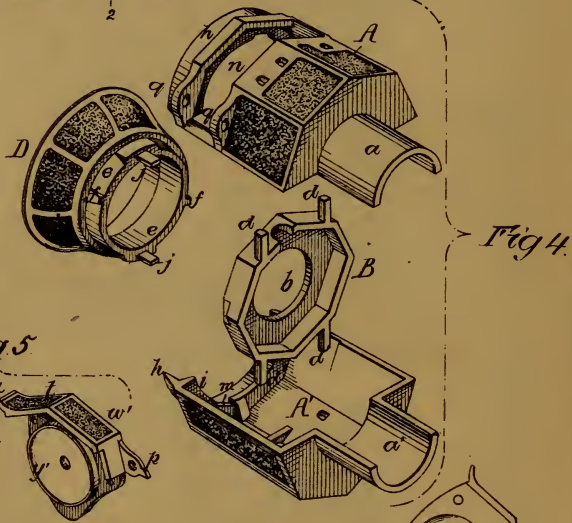
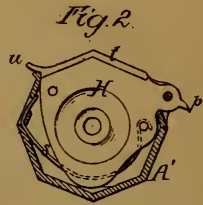
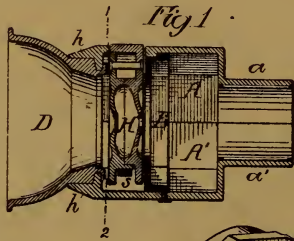

DESCHAMPS.—REGISTER.

FIG. 2.

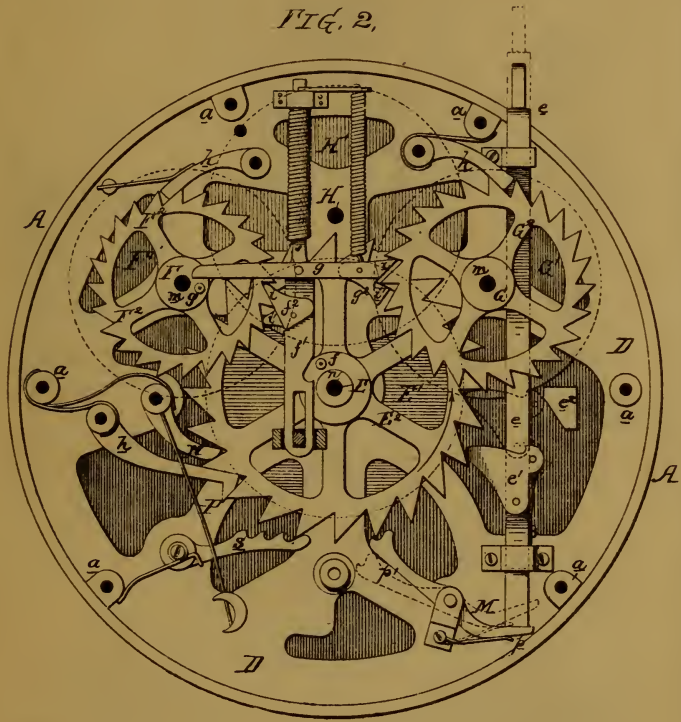

POWELL.—SPRING MOTOR.

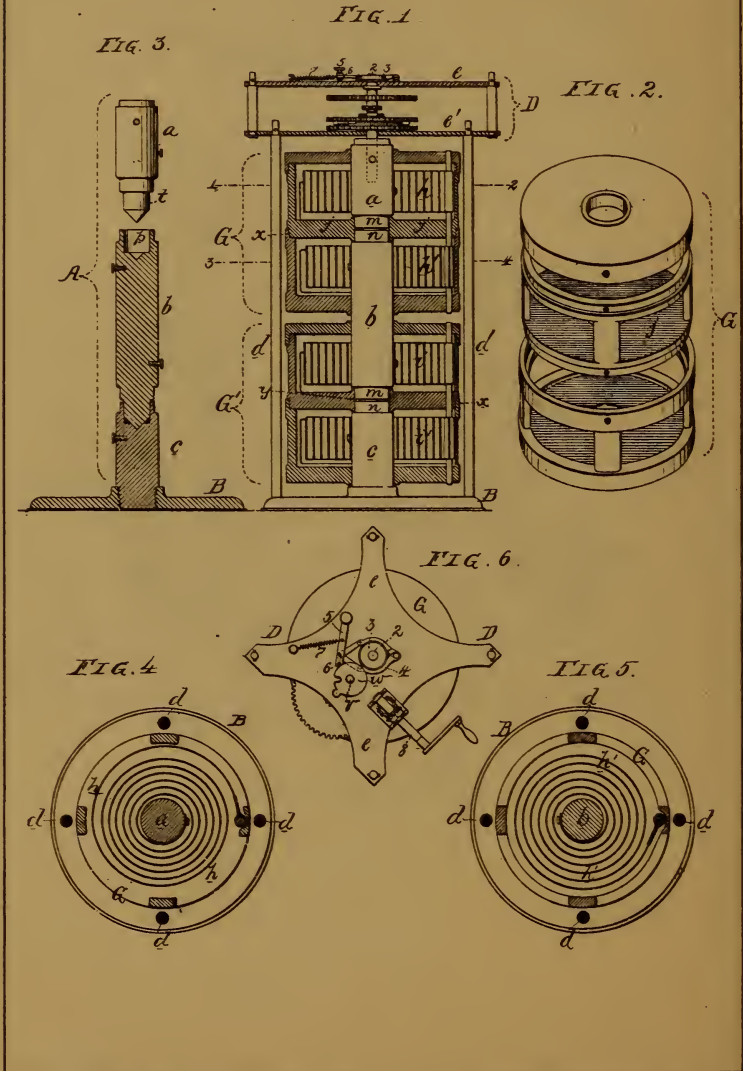

RAPP.—MOULDING PLASTIC MATERIALS.

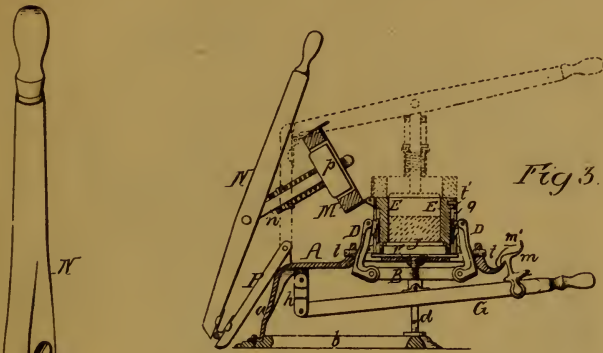

Fig 3.

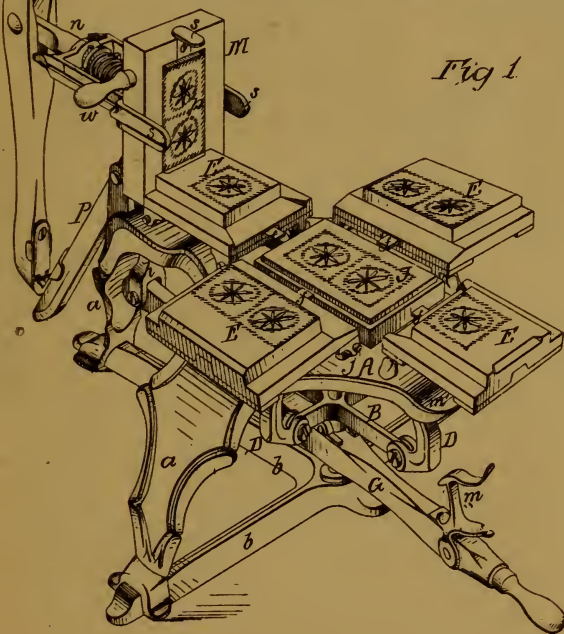
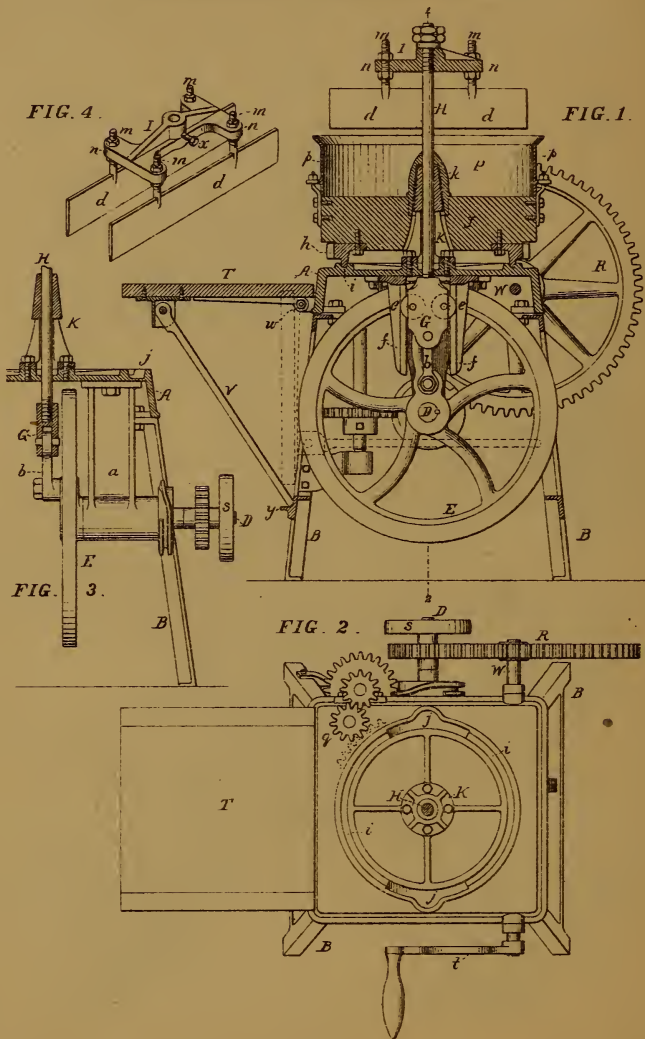

Fig 1.

NITTINGER.—MEAT CHOPPER.



THE ORIGINAL OF THIS DRAWING AND THE SPECIFICATION RELATING TO IT WERE SPECIALLY PREPARED AT THESE OFFICES, FOR THE U. S. PATENT OFFICE RULES OF JANUARY, 1880.

CLARK, REEVES & CO.
COLUMN, N. Y. ELEVATED R. R.

Fig. 3.

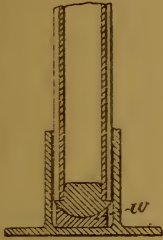

Fig. 5.

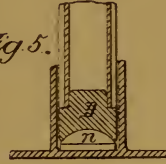

Fig. 4.

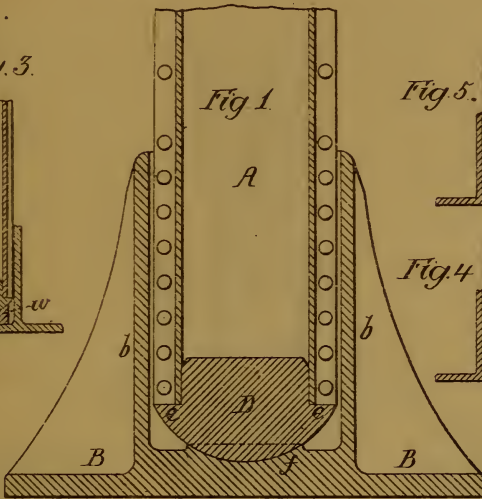
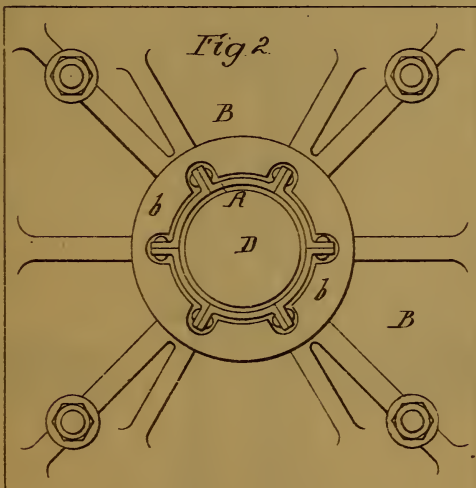
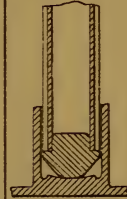

Fig. 6.

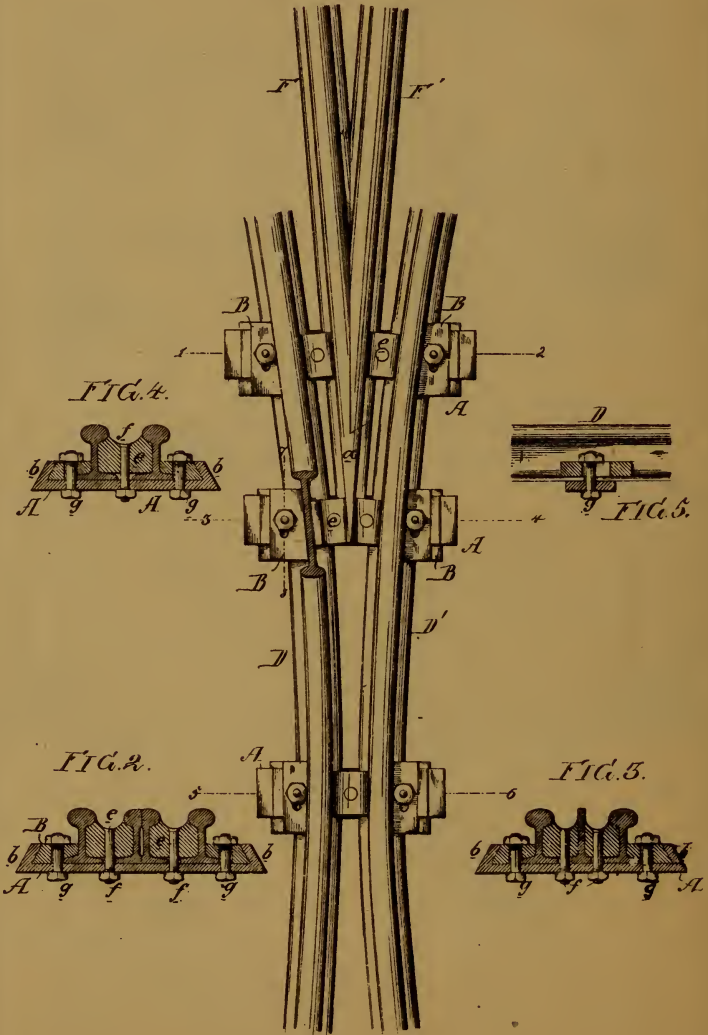

Fig. 7.



WHARTON SWITCH CO.—FROG.

FIG. 1.



WHITALL, TATUM & CO.—GLORY-HOLE FURNACE.

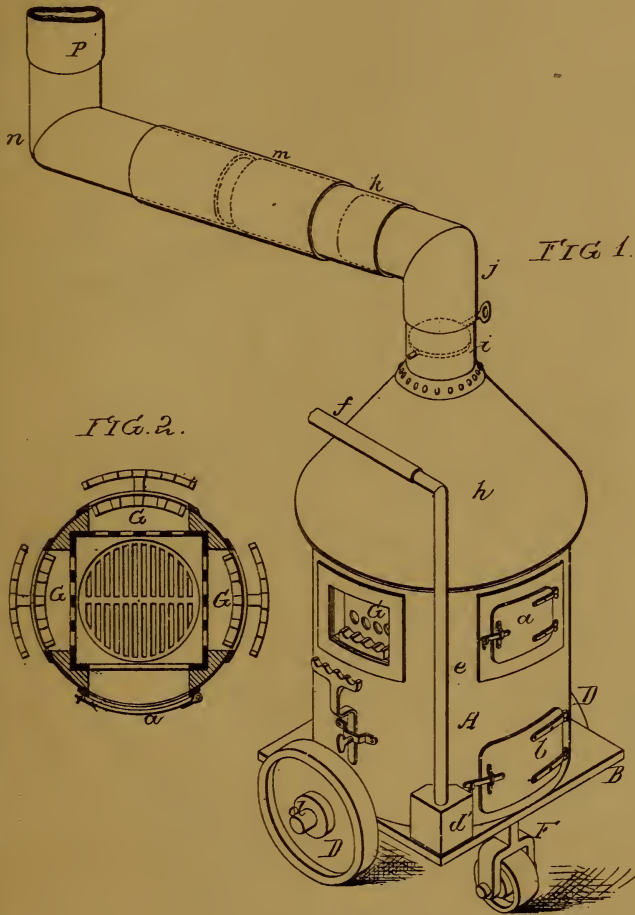

ENTERPRISE MFG. CO. & AMERICAN MACH. CO.
MRS. POTTS' SAD-IRON.—RE-ISSUE.

Fig. 3.

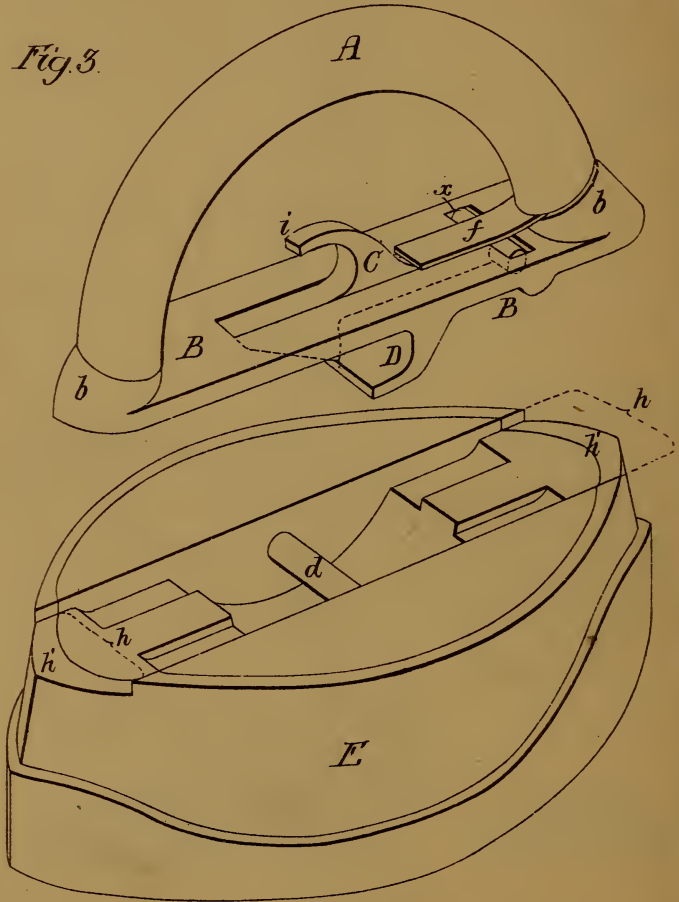





LIBRARY OF CONGRESS

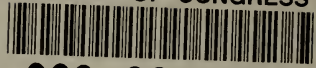

0 029 985 424 3