

TRANSFERRED TO  
YALE MEDICAL LIBRARY











Digitized by the Internet Archive  
in 2012 with funding from  
Open Knowledge Commons and Yale University, Cushing/Whitney Medical Library

# SPECTRA.

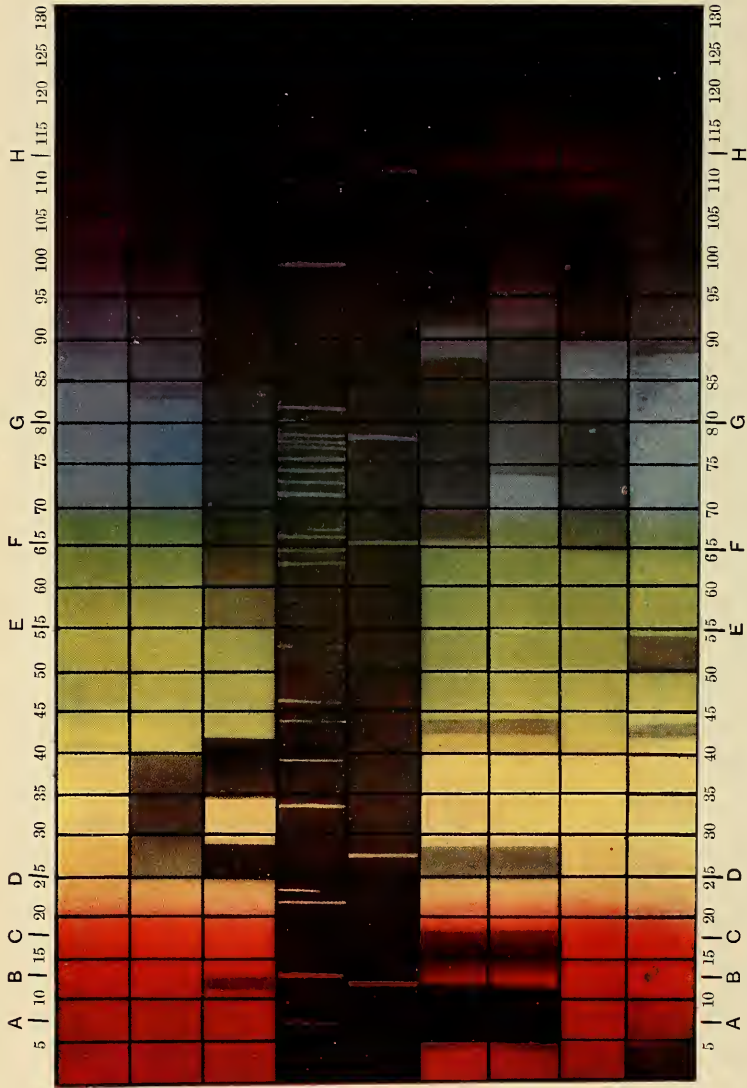

Solar.

Haemoglobin.

Methaemoglobin.

Radium.

Helium.

Chlorophyl (green).

Chlorophyl (blue-green).

Chlorophyl (yellow).

Oxyhaemoglobin.

Frontispiece to "Light Energy" by M. A. CLEAVES, M.D. (New York).

NEW YORK:  
Rebman Company.

LONDON:  
Rebman Limited.

( Copyright 1904. )



# LIGHT ENERGY

*Its Physics, Physiological Action  
and Therapeutic Applications*

By

MARGARET A. CLEAVES, M.D.

Fellow of the New York Academy of Medicine; Fellow of the American Electro-Therapeutic Association; Member of the New York County Medical Society; Fellow of the Société Française d'Électrothérapie; Fellow of the American Electro-Chemical Society; Member of the Society of American Authors; Member of the New York Electrical Society; Professor of Light Energy in the New York School of Physical Therapeutics; Late Instructor in Electro-Therapeutics in the New York Post-Graduate Medical School

*WITH NUMEROUS ILLUSTRATIONS IN THE TEXT  
AND A FRONTISPIECE IN COLORS*

"But if darkness, light and sight be separate and independent one of the other, then if you remove light and darkness, there is nothing left but void space."—*Buddhistic Sutra.*



NEW YORK  
REBMAN COMPANY  
10 WEST 23D STREET, COR. 5TH AVE.

LONDON AGENTS  
REBMAN LIMITED  
129 SHAFTESBURY AVENUE, W. C.

1904

COPYRIGHT, 1904  
BY REBMAN COMPANY, NEW YORK

---

COPYRIGHT, 1904 •  
BY REBMAN LIMITED, LONDON, ENGLAND

RM 837  
904 C

BURR PRINTING HOUSE  
NEW YORK, U.S.A.

*TO THE MANY STUDENTS*

FROM ALL PARTS OF THE COUNTRY WHO HAVE SOUGHT  
INSTRUCTION AT THE AUTHOR'S HANDS, AND WHO  
HAVE BEEN AT ONCE AN INSPIRATION AND A STIMU-  
LUS, THIS VOLUME IS DEDICATED



## PREFACE.

The subject matter of this volume on Light Energy, as applied to medicine, has been the outgrowth of eleven years' clinical experience with that part of the subject covered by light.

Its formal presentation to the profession is due to the constant demand on the part of physicians seeking post-graduate instruction at the author's hands that she should embody her experience in the form of a book.

Its pages are devoted to a practical consideration of the physics, physiological action and therapeutic effect of light energy from both natural and artificial sources, and also aim to give a compendium of the literature of this new subject up to date of going to press.

Vacuum tube discharges and radio-active substances are also considered from the physical, physiological and therapeutic points of view.

The Roentgen ray has not been considered, although properly belonging to a consideration of light energy, for the reason that the subject has been most exhaustively covered by others, and books on Radiotherapy exist in sufficient numbers. The Roentgen ray is, therefore, referred to only incidentally in its relation to light and radio-active substances, in order to establish as clearly as possible the indication for the one or the other. In the therapeutic uses of etheric vibrations, differing only in degree not kind, it is difficult to draw a line of demarcation, to say when the irregular discontinuous impulses of the Roentgen ray, itself of the nature of a single ultra-violet ray, should be used, and when the rhythmic orderly procession of the short

high-frequency vibrations of intense chemically active light is indicated. The author will feel that her labor is not in vain if the indications at least for the use of light energy are clearly set forth.

No apology is offered for considering at length the fundamental physics of light energy, especially in so far as the physical laws governing light bear upon its therapeutic application. To those more or less familiar with the subject, it may open up a line of study fascinating in the extreme. The electric arc has been treated of in considerable detail, as upon it the physician's main dependence must be placed for a source of artificial light rich in chemically active energy. The effort has been to elucidate those points only in its physics which her own personal experience in its use had indicated as essential.

The author's own methods of utilizing light energies with results have been given, and also the experiences of others as well. Every opinion formulated by others has been carefully analyzed, and the conclusions drawn therefrom submitted to vigorous criticism, especially from the physical side, before giving them place in these pages. Especially has care been taken to exclude any evidence not based upon sound fundamental physical laws. It matters not what form of energy is expended within the tissues, if the fundamental physical laws of that energy are known, and its physiological action, the therapeutic application becomes a very simple matter, involving no other principles save those fundamental to the physician.

Upon physical laws and properties, physiological action and pathological conditions, the exhibition of light energy is at once rational and comprehensive.

Light as a therapeutic measure, as well as a factor in hygiene and sanitation, is not only of importance to-day, but always will be.

In view of the fact that the continued existence of the human species on earth depends entirely on radiant energy, no apology is necessary for presenting a volume devoted

entirely to a discussion of light in its physical, physiological and therapeutical aspects to the consideration of a profession whose duty it is to minister to human life from its first inception to its final dissolution.

While light energy is as old as the sun, and so almost are its therapeutic uses, never in the history of medicine was it as fully appreciated as now. The author hopes that a study of these pages will teach the student that it is not only ultra-violet energy, but all the radiant energies of the sun or artificial sources of light which are necessary to the maintenance of health, and to the curing of disease. She also trusts that a perusal of these pages will stimulate a careful and systematic investigation of the subject, to the end of placing the general use of light energy upon a foundation equally scientific and sure, as that upon which Finsen has builded his therapy of skin diseases.

The author's acknowledgments are due to the courtesy of Dr. Gunni Busck, of the Finsen Lysinstitut, for the page proof of his work on Light Biology, which arrived in time for the incorporation of the most recent work upon sensitization of living tissues, and also for his hypothesis as to the sensitization of the organism by quinin in malaria.

The author's kindest and most cordial acknowledgments are due her friend, Dr. Elizabeth Stow Brown, not only for assistance in French translations, arrangement of accumulated data and reading of manuscript, but for her intelligent interest in the subject.

The author's acknowledgments are due to the courtesy of the *British Medical Journal* for the use of the cuts (Figs. 4 and 5) illustrating the experiments of Bernard and Morgan.

The author's acknowledgments are also due her friend, Dr. Leslie J. Meacham, for his untiring and intelligent assistance in revision of manuscript and proof.

MARGARET A. CLEAVES.

616 Madison Ave., New York City.

Sept. 15, 1904.





# CONTENTS

---

## CHAPTER I.

- Introduction: Light Energy, the Theory of. Its Manifestations, Radiant Heat, Brush Discharges in Vacuum, Visible Light, Ultra-Violet Rays, N Rays, X Rays, Cathode Rays, Alpha, Beta and Gamma Rays..... 1-22

## CHAPTER II.

- The Physics of Light Energy and Radiant Heat. Sunlight, Electric Arc Light, Incandescent Light, Mercury Vapor Light. Spark and Vacuum Tube Discharges..... 23-129

## CHAPTER III.

- The Action of Light Energy upon Elementary Forms of Life .....130-140

## CHAPTER IV.

- The Action of Light Energy upon Vegetable Organisms.....141-162

## CHAPTER V.

- The Action of Light Energy upon Bacteria.....163-203

## CHAPTER VI.

- The Action of Light Energy upon the Higher Organisms....204-223

## CHAPTER VII.

- The Physical Effects and Biological Action of Light Energy. Skin, Circulation, Nervous System, Metabolism.....224-307 ✓

## CHAPTER VIII.

- Sun Baths. Arrangements of Solaria, Methods of Use and Therapeutic Indications. Tuberculosis of Joints, Pulmonary Tuberculosis, Anæmia and Neurasthenia.....308-329

## CHAPTER IX.

- Electric Arc Baths. Arrangements of Light Mechanisms, Methods of Use and Therapeutic Indications. Pulmonary Tuberculosis, Bronchitis, Bronchial Asthma, Anæmia, Neurasthenia, Locomotor Ataxia and other Nerve Disorders.....330-396

## CHAPTER X.

- Incandescent Light Baths. Arrangement of Light Mechanisms, Methods of Use, Therapeutic Indications. Obesity, Gout and Rheumatism, Diabetes, Anæmia and Chlorosis, Toxæmias, Nephritis.....397-435

## CHAPTER XI.

- The Concentrated Visible Chemical Frequencies of the Solar Spectrum. Mechanisms, Methods of Use and Therapeutic Indications. Malignant Pustule, Diphtheritic Croup, Pneumonia, Pulmonary Tuberculosis and Lupus Vulgaris .....436-459

## CHAPTER XII.

- The Concentrated Energy of the Electric Arc Spectra, Carbon, Carbon and Iron. Iron. Mechanisms, Methods of Use and Therapeutic Indications. Lupus Vulgaris, Lupus Erythematosus, Sycosis, Eczema, Tubercular Ulcers, Tubercular Glands, Neuritis, Neuralgias. Finsen.....460-539

## CHAPTER XIII.

- The Concentrated Energy of Incandescent Light Spectra. Mechanisms, Methods of Use and Therapeutic Indications, Local Incandescent Baths, Rheumatic Joints, Chronic Synovitis, etc. Incandescent Light in Gynæcology .....540-558

## CHAPTER XIV.

- The Exclusion of All but the Frequencies of the Blue Region of the Spectrum, or the Visible Chemical Frequencies. Blue Light as by the Method of Kaiser and Minim; Its Therapeutic Indications. Contusions, Sprains. Open Wounds and Tuberculosis of Joints.....559-581

## CHAPTER XV.

- The Non-Concentrated Frequencies of the Red Region of the Spectrum or Red Light. Exclusion of all Above the Red in Smallpox and the Exanthemata. Finsen. . . . .582-601

## CHAPTER XVI.

- The Concentrated Invisible Chemical Frequencies of the Spectrum or Ultra-Violet Rays. Mechanisms, Spark Condenser Lamps Excited by Alternating Currents, High Frequency Coils or Static Machines, Methods of Use and Therapeutic Indications. . . . .602-648

## CHAPTER XVII.

- Vacuum Tube Discharges, Phenomena and Theory of. Mechanisms, Methods of Use and Therapeutic Indications . . . . .649-674

## CHAPTER XVIII.

- N Rays. Their Place in the Spectrum and Relation to the Living Organism. Blondlot and Charpentier. . . . .675-692

## CHAPTER XIX.

- Alpha, Beta and Gamma Rays of Radio-Active Substances. Uranium, Thorium, Polonium, Actinium and Radium. Radium: Its Physics, Physiological Action and Therapeutic Value. Prof. and Mme. Curie. . . . .693-750

## CHAPTER XX.

- Fluorescence, Fluorescent Stimulation, Sensitization. Therapeutic Uses in Cancer, Lupus Vulgaris, Condylomata, Indurated Chancre and Malaria. . . . .751-788

## CHAPTER XXI.

- The Pernicious Effect of Sunlight; Insolation. Pathological Effects of Electric Lighting. . . . .789-811



## LIST OF ILLUSTRATIONS

FIG.	PAGE
1. Arc Light Carbons Showing Positive Crater and Negative Nipple, etc. . . . .	facing 89
2. Langley's Plate, Showing Energy Curve of Different Sources of Light . . . . .	facing 128
3. Langley's Plate, Showing Energy Curve, Sun and Firefly Spectra . . . . .	facing 128
4. Experiment with Dead Frog's Foot . . . . .	facing 182
5. Action of Ultra-Violet Light on Bacteria . . . . .	facing 182
6. { Sections Showing Action of Light upon the Skin.	
7. { Möller . . . . .	facing 252
8. {	
9. Fraunhofer's Lines . . . . .	facing 252
10. Arc Light Cabinet . . . . .	facing 334
11. Diagram Indicating Luminous Intensity Alternating-Current Arc . . . . .	394
12. Diagram Indicating Luminous Intensity Continuous-Current Arc . . . . .	394
13. Incandescent Cabinet, open . . . . .	facing 402
14. Incandescent Cabinet, closed . . . . .	facing 402
15. Sun Lens, . . . . .	facing 438
16. Diagrammatic Cut of Finsen's Concentrator . . . . .	466
17. Finsen's Apparatus . . . . .	467
18. Compressor . . . . .	470
19. Victor Lamp . . . . .	473
20. Lortet-Genoud Lamp . . . . .	473
21. Marine Searchlight, with Blue Glass Screen . . . . .	facing 478
22. Marine Searchlight, on High Stand . . . . .	facing 478
23. Marine Searchlight, with Funnel-shaped Attachment . . . . .	facing 480
24. Iron Electrode Lamp . . . . .	485
25. Piffard Iron Electrode Lamp . . . . .	487
26. Compressor . . . . .	497
27. Compressor . . . . .	497

28.	Giant Cell from a Case of Lupus after Two Light Treatments . . . . .	facing	536
29.	Section of Lupus Nodule after Four Light Treatments . . . . .	facing	536
30.	Local Light Baths . . . . .	facing	542
31.	Water-cooled Vaginal Lamp . . . . .	facing	542
32.	Minim Lamp . . . . .		579
33.	Electroscope . . . . .		614
34.	Ultra-Violet Rays Discharging a Piece of Zinc . . . . .		618
35.	The Görl Lamp . . . . .		624
36.	Showing Connections for Ultra-Violet Lamp with Leyden Jars in circuit . . . . .		625
37.	Line Cut Showing Method of Securing Ultra-Violet Rays from Alternating-Current Mains . . . . .		628
38.	The "Ultra-Violet" Lamp . . . . .	facing	630
39.	Cut Showing Upward Movement of Spark through Ionized and Heated Air . . . . .		662
40.	Interrupters . . . . .		668
41.	Vacuum Tubes with Leading-in Wires . . . . .		669
42.	Vacuum Tubes without Leading-in Wires . . . . .		670
43.	Strutt's Apparatus for Demonstrating the Absorption of Radium Radiations . . . . .		704
44.	Paschen's Modification of Above . . . . .		705
45.	Line Cut Showing Magnetic Field of Radium . . . . .		708
46.	Radium-graph of Mouse . . . . .	facing	718
47.	Radium-graph of Dead Human Hand . . . . .	facing	718
48.	Radium-graph of Mouse in Trap . . . . .	facing	719
49.	Diagrammatic Representation of Seed-growth under Radium . . . . .		743
50.	Radium Receptacle for the Stomach . . . . .		749
51.	Radium Receptacle for the Oesophagus and Rectum . . . . .		749
52.	Radium Applicator Set, No. 1 . . . . .	facing	750
53.	Radium Applicator Set, No. 2 . . . . .	facing	750
54.	Therapeutic Arc Lamp . . . . .	facing	462
55.	The Cleaves Arc Lamp . . . . .	facing	464

## CHAPTER I.

**Introduction:** Light Energy, the Theory of. Its Manifestations, Radiant Heat, Brush Discharges in Vacuum, Visible Light, Ultra-Violet Rays, N Rays, X Rays, Cathode Rays, Alpha, Beta and Gamma Rays.

### **Light Energy.**

Energy is defined by Professor Barker "as a condition of matter in virtue of which any definite portion may effect changes in any other definite portion." It is regarded as the potential of the universe, and when matter is in a phase permitting activity, all other quantities of a matter at a distance are affected. The method of transfer of energy through space is universally conceded to be by means of wave motion through the ether, the eternal recipient and universal transmitter of Nature's infinite energy. Throughout space all matter is vibrating from the lowest musical note to the highest pitch of the chemical rays. The various manifestations of energy known as sound, heat, light, electricity and chemical action, are all vibrations of this universal, homogeneous, incompressible continuous body, which is incapable of being resolved into simpler elements or atoms.

These various manifestations of energy are recognized as such according as they are perceived by different nerves, for the mind of man translates the impressions of the world into facts of consciousness and thought by means of the

nerves of the human body. All these varying rates of vibration, differing as they do only in direction, rate and frequency, are interpreted according to the different nerves or groups of nerves physically attuned to them, or organized to select and respond to especial manifestation of vibratory activity. The optic nerve transmits to the retina and the brain the sensation of light, and its function is limited to the phenomena of radiation. It is wonderfully sensible to certain impressions of this class, but on the other hand is very little affected by, even obtuse to other impressions. Vibrations which affect the sense of touch, taste, smell or the senses can be educated to take the place of the optic nerve to a very great extent, functioning in such a way as to carry correct impressions, ordinarily received by way of the optic nerve, to the brain. Nor does the optic nerve perceive the entire range of radiation. Its function is not excited by all the rays which reach it, while there are others which never reach it at all, being absorbed by the humors of the eye, and producing thereby the brilliancy characteristic of it. Invisible rays are emitted by non-luminous bodies, as there is no body in nature absolutely cold, and every body not absolutely cold emits rays of heat. But in order that radiant heat may affect the optic nerve a certain temperature must be reached. As the temperature is increased, in a platinum wire, for example, through which a gradually increasing current is sent, the wire, by reason of its great resistance, first becomes warmer to the touch, then increasingly warm, next glowing with a red light, and as the current is increased becoming brilliantly incandescent.<sup>1</sup> This phenomenon, which is comparable to the light of the sun, affects the retina and excites the sensation of vision.

The author's conception of light and its action is based upon the now accepted undulatory theory, and is coupled with the belief that all space is saturated with the inconceivably minute corpuscles discovered by J. J. Thomson.<sup>2</sup>

---

<sup>1</sup>Tyndall: *Fragments of Science* "Radiation."

<sup>2</sup>J. J. Thomson: *Conductivity of Electricity through Gases.*



These are regarded as either electricity in its ultimate refinement, as very closely allied to it, or its immediate carriers. The "corpuscle" of Thomson is only the one-thousandth part of the mass of any known particle of matter. The astro-physicists, who accept the corpuscular theory, believe "that the earth and sun, all suns and dark bodies in space, all granular matter, move through the primordial cosmical mass of electrical corpuscles as would a wire screen through water."<sup>1</sup> These bodies, smaller than atoms, are able to pass through the wide spaces, comparatively speaking, of diamonds, glass, steel, flint, etc.

Thomson's corpuscles are positive, and negative in their electrical discharges, the positive carriers of electricity having a size comparable to ordinary atoms of gross matter, but the corpuscles that flow between the atoms of all types of matter are negative. Matter in a state of activity sends out continuously the same kind of corpuscles that fill all space. The sun in its never-ending state of activity, turbulent, tossed into fantastic shapes, is to be regarded as a source of negatively electrified corpuscles which stream through the solar system.

The most intense radiance known is that of sunlight, and when put in candle-power, the figures are so enormous as to convey but little idea to the mind of its intensity. 1,575,000,000,000,000,000,000,000,000, or fifteen hundred and seventy-five billions of billions enumerated according to the English method.<sup>2</sup>

Langley made a careful comparison between the solar radiation and that of the blinding surface of the molten metal in a Bessemer converter. The brilliancy of this metal is so great that the dazzling stream of melted iron, which is poured in at one stage of the proceedings to mix with the metal already in the crucible, "is deep brown by comparison, presenting a contrast like that of dark coffee poured into a white cup." In conducting his experiments every advan-

---

<sup>1</sup>Larkin: Radiant Energy.

<sup>2</sup>Young: The Sun.

tage was given to the metal in order to institute a comparison between the brilliancy of the metal and the sunlight. No allowances were made for the losses encountered by the latter during its passage through the smoky air of Pittsburgh to the reflector, which threw its rays into the photometric apparatus. Despite this disadvantage the sunlight came out five thousand three hundred times brighter than the dazzling radiance of the incandescent metal.

The radiant energy falling upon the deck of an ocean liner is sufficient, if it could be utilized, to propel the ship with greater speed than is now obtained from carbon, if the radiation received were not cut off by the air. The air cuts off fully one-third.

On an ostrich farm in South Pasadena is a great solar motor which has an indicated output of 11 horsepower, with 210 pounds of steam, which can pump water at a maximum rate of 1,400 gallons per minute.<sup>1</sup>

The inconceivably rapid and minute oscillating light corpuscles of the invisible region beyond the violet have a chemical energy so intense as to destroy micro-organic life, to wreck the molecules of nitrite of amyl, of iodine vapor, to produce erythema of the skin and underlying changes; effects dependent upon the accumulation of the periodical strokes of their oscillating swing until the atoms upon which their timed impulses impinge are jerked asunder. It is this energy in its various manifestations to which this volume is devoted. When light is conceived of in this manner, the reason for its power in continuing life and in curing disease becomes evident at once.

### Theory of Light.

Various hypotheses have been formulated in order to explain the origin and transmission of light.

The most important of these are the *emission* or *corpuscular* theory and the *undulatory* theory.

---

<sup>1</sup>Larkin: Radiant Energy.

On the emission theory it is assumed that luminous bodies emit, in all directions, an imponderable substance which consists of molecules of extreme degree of tenuity; these are propagated in right lines with an almost infinite velocity.

On the undulatory theory of Huygens, light consists of wave motions of the ether, the vibrations being transmitted from particle to particle with an extremely high velocity in straight lines; the vibrations of the particles of the ether are at right angles to the path of the ray.

An idea of this wave motion may be given by shaking a rope at one end, the vibrations, or to-and-fro movements of the particles of the rope are at right angles to the length of the rope, but the onward motion is in the direction of the rope's length.

The luminosity of a body is due to an infinitely rapid vibratory motion of its molecules which, when communicated to the ether, is propagated in all directions in the forms of spherical waves, and this vibratory motion, being thus transmitted to the retina, calls forth the sensation of vision.

The emission theory was supported by Newton, and is spoken of as Newton's corpuscular theory. Euler enunciated the undulatory theory subsequently to Huygens. Since the discovery of the Thomsonian corpuscle and radium the question has arisen as to whether there will not be a reversion to the emission or corpuscular theory. The undulatory theory stands, however, and upon it many optical phenomena, particularly those of diffraction, as shown by Young, can be explained. Energy is the potential of the universe. When matter is in a phase permitting it to be active other quantities of matter at a distance are affected. This transfer is known to be by means of wave motion. Each separate impulse moves from the emitting to the receiving mass on a rigorously straight line. One individual continuous set of oscillations in this straight line is called a ray. If all space is saturated with the inconceivably minute cor-

puscles of Thomson, as there is reason to believe, each negative Thomsonian corpuscle makes a double vibration to and fro like a pendulum (the transmission to-and-fro of the rope illustration) straight across the direction of the ray, i.e., at right angles to it. The corpuscle moves over and returns to the position it had originally before the excursion. After one corpuscle makes an oscillation across the direction of the ray and returns the next does likewise, and the next, and so indefinitely. After the first corpuscle makes a swing, another distant from it 186,000 miles will also make a vibration at the end of the first second of time in the same straight line.

Since these Thomsonian corpuscles are negative and can be drawn out of their original straight path by the action of magnetism, the entire wave motion of the universe is electro-magnetic. This, says Larkin, whose description of the movement of the oscillating light corpuscles is given, was prophesied by Maxwell forty years since. The fulfilment of the prophecy was left to Thomson. There is really no such thing as a ray of light, nor for that matter of pencils consisting of a number of rays. The straight line along the middle of a wave or set of waves as illustrated by the length of the rope is simply to indicate the direction of the waves, and in a graphic representation it also serves to show the amplitude on either side of the frequency of the oscillating light corpuscle. The amplitude is the distance of the sides of the waves from the illustrative central line of the ray. It represents the distance of the swing of the corpuscle on each side of this imaginary straight line.

As each wave is 186,000 miles distant from its source at the end of one second, there must follow variations in the length of the waves. Those of the greatest amplitude, i.e., distance of swing of the oscillating light corpuscle from this straight line, will of necessity be the longest, fewer in a centimetre, because of the space required for them to swing.

### Light Energy: Its Manifestations.

Since Roentgen's discovery in 1896 a host of radiations have sprung into prominence, many of which have a relation to physiologic processes, and are applicable to therapeutics. Among these may be enumerated radiant heat, brush discharges in vacuum, light, ultra-violet rays, N rays, cathode rays, X rays and the alpha, beta and gamma rays of radioactive substances.

These latter will receive especial consideration in a subsequent chapter devoted to that subject, and their identity with rays emanating from other sources set forth. All these radiant phenomena are vibrational activities of the all-pervading ether and their differences physically, chemically and physiologically are due to their varying rates of frequency.

As with electricity so with light. There is an enormous range of frequency available. These varying rates of vibrational activity are not all continuous. In the lack of continuity the X ray differs essentially from rays of the continuous solar spectrum.

While it has not yet been proved it is probable that the slowest waves which go around the earth are due to the electric waves from the sun. Then come what are called Langley waves, radiant heat waves, Paschen's waves, and waves which get shorter and shorter, the luminous waves, i.e., the different colored waves of the spectrum, N rays, and, finally, still shorter waves, and at the higher frequencies of the ultra-violet region up to the Becquerel or X rays.

The cathode rays are of a different order, and consist of negatively charged particles or corpuscles, as Thomson calls them. These are the electrons of Crookes. They move with the velocity of from 1-5 to 1-3 that of light. The corpuscle with its charge is identical with the electron. Thomson's corpuscles are positive and negative in electrical charge, the positive carriers of electricity being comparable in size to ordinary atoms of gross matter, the negative cor-

puscles flowing between the atoms of all types of matter very minute. By their impact against obstacles, the target of a Crookes tube, they produce Roentgen rays. Becquerel rays, discovered by Becquerel in his experiments with uranium nitrate, were at first supposed to be different from Roentgen rays in being capable of polarization and refraction. This supposition of Becquerel's, both he and others subsequently disproved. They are also identical with the penetrable radiations of radio-active substances. All the phenomena considered, therefore, may be regarded strictly as manifestations of light.

### Radiant Heat.

Radiant heat, considered in its proper place in its physical, physiological, and therapeutic relation, is another manifestation of light energy.

Radiant heat differs essentially from hot air. A thermometer exposed to radiant heat gives no trustworthy indications.

Powerful as these rays are, and sufficient to fuse many metals, they can be permitted to enter the eye and break upon the retina without producing the least luminous impression. Gather them in a focus and there is nothing to be seen at the place of convergence. With a proper thermometer it could be proved that even the air at the focus is just as cold as the surrounding air. The deduction from this is that the ether at the focus is practically detached from the surrounding air, that the most violent ethereal motion may there exist without the least aerial motion, invisible, yet the thermal energy is sufficient to raise iron to a temperature at which it throws off brilliant scintillations.<sup>1</sup> In the invisible region below the red, before the swings or excursions to and fro of the particle of iron become rapid enough to emit dull red, waves are issuing which are too long and slow to have effect on the retinal nerves. The

---

<sup>1</sup>Tyndall.

atoms of some bodies refuse to partake of motion of the powerful waves of low refrangibility and, therefore, remain unaffected by their heat. Such is not the case of the tissues of the living organism. Upon it radiant heat exercises a profound influence, producing an effect beyond the skin by entering the body as a radiant force. Through the large superficies acted upon there are sent co-extensive ingoing impressions to nervous centres from which they are reflected to the various internal organs.

Langley, with his bolometer or platinum nerve, has investigated this end of the spectrum, and his map of the infra-red end of the spectrum is 13 times as long as that of the visible spectrum.

The waves or frequencies manifested as radiant heat have varying intensities out to the extreme limit. This part of the spectrum is full of lines and bands which vary as much in width as do those of the visible spectrum. They indicate absorption, for absorption is the cause of all dark and cold spaces in the solar spectrum. Cold in this part of the spectrum corresponds to darkness in the visible.

The bolometer or platinum nerve shows itself more sensitive in detecting the long and slow waves beyond the red than the eye, just as the fluorescent screen slows down the waves beyond the fastest violet or the ultra-violet, rendering them visible. The human nerves, to the human sense most exquisitely sensitive, are not, therefore, as sensitive as supposed, for platinum and silver are both more sensitive.

### Brush Discharges.

There proceed from the sun magnificent waves, one oscillation in  $6\frac{1}{2}$  seconds producing another oscillation. In the earth, however, the frequency of an electric oscillation is 17 per second. But electric oscillations may be made to run up to 50,000 millions per second, while with suitable Leyden jars appropriately connected with a source of E. M. F. the frequency may run up to 30 and 100 millions. Every oscillation of the discharge between these jars sends out a

wave, like a stone falling into water. But if the two discharging knobs be drawn far enough apart there is no longer sufficient potential of this miniature lightning discharge to break down the air, so it expands into a brush of blue light—electricity—like the brushes of a paint brush if widely separated. This constitutes the brush discharge, and in nature it finds its counterpart in aurora. To every one familiar with the phenomenon of this discharge from high tension coils or from Holtz machines the absolute identity of the two phenomena is at once apparent. "The light of the aurora, although caused by the sun, does not come direct but is caused by the turbulence set up in the earth's magnetic field by electro-magnetic upheaval on the sun. The field of the earth is tuned for that of the sun, as are coherers in sympathetic telegraphy and telephoning. The phenomena of the aurora are electrical, affecting magnets and compass needles on ships." So also is the brush discharge. In this connection this discharge concerns us not as it streams from the terminal balls of the discharging rods when there is no longer sufficient potential to cause a disruptive discharge, nor as it streams from the edges of the insulating platform nor from wooden balls and points, but when discharged in vacuo. These tubes when connected by their platinum terminals to an excited static machine or a high tension coil glow with supernal radiance. The light oscillates with great rapidity. In their behavior they have been likened to the oscillating discharges of the "auroræ hung up above the poles of the earth." The phenomena occurring in these tubes of varying degrees of vacuity "are in that mystical place, the dim borderland between radiant energy and radiant matter if indeed there is any boundary between, for Thomson's corpuscles and Crookes' electrons, although matter, behave like radiant energy."

These discharges, electro-magnetic, present then the phenomena of light and electricity. They are chemical in their action, and the frequencies of the light energy vary



according to the degree of vacuum. The theory of these discharges in vacuum, as well as their physiological and therapeutic applications, assume their place in Chapter XVII.

### Luminous or Visible Rays.

Ascending the scale or heating the iron still hotter than for the purposes of heat emission only a dull red appears. By increasing the heat, there will develop all shades of red from a dull to a bright color. If these rays be reflected through a prism upon a white screen a band of red light will be seen extending from a deep to a bright red. It is not hot enough to emit other than red, that is, its particles do not oscillate fast enough to send forth any other lengths of waves. If the iron is heated still hotter until it loses its red color and becomes white, if reflected through a prism upon a screen, a continuous spectrum will be seen. A still more intense heat and the color band still complete becomes brighter than before. This spectrum is continuous because all the frequencies from the long and slow of the red on up to the orange, yellow, green, blue, indigo and violet, diminishing gradually in length and increasing correspondingly in frequency, and of gradually diminishing amplitude, are present.

When an inch contains from 36,000 to 61,000 of these electro-magnetic undulations their effect upon human sensation, by reason of the retina, is that of light. Their number compensates for their minuteness. Trillions of them enter the eye and hit the retina in the time consumed in the utterance of the shortest sentence.

The shortest violet wave, just before extinction in the ultra-violet region, is of such lengths that 61,000 are within one inch. As illustrative of the extreme shortness of these waves is the fact that the highest musical sound caused by an oscillating piano wire 4,000 times per second is conveyed by a wave 3 1-3 inches long. All sound waves are, however, extremely long as compared with light waves.

This continuous spectrum has been likened to the keyboard of an organ with every key open, the bellows being in constant action, the bellows corresponding to the continuous shining of the sun or other sources of white light.<sup>1</sup>

The continuous spectrum is very valuable in its physical, physiological and therapeutic relations. This is not only true of one region or one color, but of the complex of frequencies of which it is made up.

### Ultra-Violet Rays.

Bordering on the extreme end of the violet of the continuous spectrum is that mystical region, the ultra-violet. It has been and is the subject of constant study and interest to the physicist, and is constantly being explored with intense interest. Since the work of Finsen it has been of great prominence in the medical world. The absence of strict scientific knowledge of the nature of the inconceivably rapid oscillations of the light corpuscles of this region, invisible to the eye save as made visible by a fluorescent medium or in their appeal to the imagination, caused results obtained from sources of light energy, absolutely barren of ultra-violet manifestations, to be attributed to them. More, the physiologic phenomena and therapeutic results from the use of various sources of light energy have been misinterpreted, and results obtained from the use of light, whether from the solar light sifted through a glass lens or an incandescent light with a blue glass enclosing bulb, have been attributed to ultra-violet light energy, although these rays have been absorbed by the intervening medium of glass in both instances, and very feebly generated, if at all, in the latter instance. The complex of light energy and its relation to therapeutic result, has not been correctly interpreted and analyzed. Valuable as are these invisible frequencies,

---

<sup>1</sup>Larkin: Radiant Energy.

their value is greater when associated with the blue violet of the continuous spectrum or its entire radiance. In its appropriate place, ultra-violet energy receives full consideration from the physical, physiological and therapeutic points of view. The detailed physics of ultra-violet frequencies, of unsurpassed interest, as for that matter is the physical side of all forms of energy, is taken up in connection with their physiologic and therapeutic action in an especial chapter rather than under the general physics of light energy. It is not that ultra-violet frequencies are to be disassociated from the spectrum, but quite the contrary.

By the increased temperature of our illustrative iron the excursions to and fro of the oscillating light corpuscles become faster and faster, and with their increased rapidity the amplitude of their swing from side to side is correspondingly lessened. The length of the spectrum beyond the measured ultra-violet is still unknown, but it seems certain that these invisible frequencies become shorter and shorter until they are merged into Roentgen waves.

### **The N Rays.**

According to the latest report the N rays discovered by Blondlot take their place in the violet region of the spectrum.

As yet there exists a great deal of scepticism as to their existence. They are by no means impossible, they are even probable, but they are not yet an established scientific fact. It would not be strange if a chemism such as the living organism should emit rays of some nature. There is considerable collateral scientific fact to support this view. Suffice it to say if the existence of rays emanating from the human body or tissues is proved, it is quite likely that they will become of equal if not of greater importance than any of the other rays. The discovery, nature and relation of these rays to the living organism are considered especially in a subsequent chapter.

### Roentgen or X Rays.

A beam of light which has passed through a prism is bent aside, or refracted.

To the question why are these waves bent differently when they strike a piece of matter obliquely, the answer has been given by distinguished physicists, Stokes, Lord Kelvin and others, because of the heterogeneity of matter. Matter is composed of particles or atoms or molecules of infinite size not incomparable with the size of the waves. In the homogeneity of matter, that is, with all its parts similar, as is the case with ether, there would be no such dispersion or sorting out of the waves. They might be bent, but they would not all be bent alike. Dispersion, or separation of the waves, into their different sizes depends upon the size and oscillation frequency of the atom. The size of the atom can be estimated by the amount of dispersion. Were the atoms either enormously larger or extremely smaller than light waves, then there would be no dispersion. But if they are at all comparable in size, then the waves which are similar to them in size are most affected. As the atoms are much smaller than the waves the greatest effect is upon the blue-violet and ultra-violet.<sup>1</sup> They are more nearly in sympathetic resonance with them, and it is for this reason that physically these frequencies are capable of influencing most profoundly molecules or groups of molecules in the living organism. The longer and slower frequencies, from the green down to the infra-red, are much less affected. Until the discovery of Roentgen the spectrum was limited by the ultra-violet.

According to Helmholtz' theory of dispersion, the existence of still smaller waves would ultimately give waves smaller than atoms. This being the case these waves would be bent less, not more, and the result would be a reversal

---

<sup>1</sup>Sir Oliver Lodge: Archives of Roentgen Ray. March to June, 1904.

of the dispersion of the upper part of the spectrum. In other words, the spectrum would be folded back upon itself, and when the infinitely small waves were reached they would not be bent at all, but would go straight on. From this theory of dispersion it is, therefore, clear that starting at the lower end of the spectrum, where the waves are infinitely long, the spectrum would double back upon itself until the waves would be comparable to an atom in size, so that ultimately from the shortest possible waves there would be no bending at all. In the X ray, Helmholtz' mathematical theory finds its proof.

They are very rapid, excessively short, smaller in fact than anything conceived of before. They are not bent and they go straight on. In this going straight on without any deviation they are distinctive from the ultra-violet ray. Still further, unlike the rhythmic continuous movement of light or, in this especial comparative instance, ultra-violet light, they are discontinuous, and as yet there is no means of rendering them continuous. They are a single solitary ether pulse, up and down almost instantly, and then cessation. They may be likened to an energetic whip crack, a falling of a brickbat, a jangle, not a harmony coming again and again but infrequently once in a thousand years or so in the life of an oscillating ultra-violet wave.

The X ray proceeds from the target with every blow of the electron, and in rapid succession as the target is being bombarded by the electrons or cathode rays in very large numbers.

In the inconceivably small size of these waves, in their suddenness, so to speak, and infrequency, they probably act physically to reinstate the vibrations of atomic structures in diseases not yet wholly departed from their normal period of vibration.

The property of ionization is possessed in common by ultra-violet, cathode and Roentgen rays.

### Cathode Rays.

In the dark space of a vacuum tube the most interesting phenomena take place. It is where the cathode rays are formed. These cathode rays are particles of electricity shot off from the negative terminal. They are really the negative corpuscles of Thomson. A ray in the mind of the physicist is generally associated with an undulatory motion of the ether. This, says Thomson, is only an accidental association, and there is no necessary connection between a ray and undulatory motion. Those negative corpuscles or cathode rays have an extraordinary resemblance to the conditions postulated in the corpuscular theory of light. They travel in straight lines, they are shot off with tremendous speed, a speed able to carry them about 20,000 miles per second from the negative terminal, or cathode of a Crookes tube. Cathode particles have been observed in a tube having a velocity as much as one-third of light. In their very high speed they are comparable only to light.

Mass of a Negative Corpuscle.—They have but small mass weighing much less than an atom. The mass of each of these particles is only about one-thousandth part of that of the atom of hydrogen, the smallest mass recognized before Thomson's discovery.

Emission of Cathode Rays by Radium.—There are some substances which are perpetually emitting cathode rays, notably, as was shown by Becquerel, uranium and its compounds. Radium, however, possesses this property to an enormously greater extent than excited Crookes tubes.

Velocity Greater from Radium.—The velocity with which the corpuscles are emitted from radium is about two-thirds that of light, and is double the highest velocity which Thomson, in his experimental work, was able to obtain in an exhausted tube excited by the most powerful induction coil.

Phosphorescence Excited by Cathode Rays.—When the residual gas is removed they will infringe on the walls of the tube and make them phosphorescent. The phosphorescence

of the glass produced by them is not a unique one, as it is shown by many substances. Rock salt becomes a pretty violet blue under their influence, and if kept dry, will last a long time. Glass is changed by a long exposure and loses its power of phosphorescence. In other words, it becomes tired, as it were, under the excessive bombardment.

Thermal Effects Produced by Cathode Rays.—Bodies upon which they fall are heated by cathode rays, and if concentrated by using a portion of a hollow cylinder or spherical shell as a cathode, platinum may be raised to incandescence, thin pieces of glass fused and diamond charred by them. The energy possessed by the corpuscles striking the body Thomson estimates at nearly two calories per minute.

Production of Roentgen Rays by the Impact of Negative Corpuscles.—The most widely known property of the cathode rays is that of producing the Roentgen rays. They are the parents, so to speak, of the Roentgen rays, for the latter are produced whenever the cathode rays strike against a solid obstacle.

By the use of a platinum target in a Crookes tube, the cathode rays are stopped and the X rays produced. It is not that the cathode rays are reflected, but as every single negative corpuscle strikes the target there is emitted by the sudden stoppage of the electric charge a single wave. "Just as the disturbance made by shaking a whip travels down the whiplash, so each of these cathode rays as it stops gives an ethereal crack as it were." These "ethereal shells," or solitary pulses, are excited by the impact of the cathode rays upon the target, just as sound or heat is caused by the impact of the bullet.<sup>1</sup>

Lenard's Experiment; Transmission of Cathode Rays.—Lenard's discovery, just antedating Roentgen's, consisted in bringing cathode rays outside a vacuum tube. "Before this the cathode rays could not be used for a therapeutic

---

<sup>1</sup>Sir Oliver Lodge.

purpose."<sup>1</sup> By facing his vacuum tube with a very thin piece of aluminum foil Lenard succeeded in getting them out. These rays are penetrating enough to get into ordinary air, but they are stopped by ordinary matter. Aluminum stops them less than any other solid matter. At the time of Lenard's discovery, the strange effects of these penetrative aluminum rays received but little attention.

Similar Effects to Roentgen Rays.—After Roentgen's discovery they came more into prominence, and the effects were found to be precisely similar to the effects of the Roentgen rays, with, however, slightly different properties. They are similar in their (1) penetrative effects, can go through metal; (2) ability to affect photographic plates; (3) to discharge Leyden jars; (4) to make gas, through which they pass a conductor of electricity; (5) production of phosphorescence in substances against which they strike.

Although capable of producing photographic effects, radiographs cannot be produced by them, as the flesh arrests them and prevents the showing of the bones.

Cathode rays outside the tube are, therefore, called Lenard's rays, as he was the first physicist to cross the Rubicon between the inside and the outside of a vacuum tube.

Thermo-Luminescence Produced by Cathode Rays.—Cathode rays produce in some substances, discovered by Professor E. Wiedemann, a thermo-luminescence. For example, a mixture of sulphate of calcium with a little sulphate of manganese is not altered in its appearance by the rays, but for some time after its exposure it bursts into a vivid greenish glow when slightly heated.

Mechanical Effects Produced by Cathode Rays.—Other than the properties possessed in common with the Roentgen rays, cathode rays have the property of producing motion of objects against which they strike. This is very prettily shown in the experiment due to Sir William Crookes, with a little mill having a series of vanes, the axle of which is

---

<sup>1</sup>Sir Oliver Lodge.



mounted on glass rails within the vacuum tube. When the discharge passes through the tube the cathode rays strike against the upper vanes, and the wheel rotates and travels from the negative to the positive end of the tube. At the same time, if the vanes are covered with suitable media they show a beautiful phosphorescent gleam.

Electric Charge Carried by Cathode Rays.—Cathode rays carry a negative electric charge, and the negative electrification follows the same course as rays producing phosphorescence on the glass.

Gas through which Cathode Rays Become a Conductor of Electricity.—In their passage through the rarefied gas of the tube they change it from an insulator to a conductor of electricity as soon as it is traversed by them. The cathode rays really constitute an electric current, they are really electrons in rapid motion. For that matter any electric current consists of electrons in rapid motion. They cannot be seen as in high vacuum because they are not usually free to move. A stream of electrons may be driven down a conductor in such a manner as to show that they are producing current. This was done by Faraday years ago, who did not know, however, what was occurring. As they pass from hand to hand, as it were, by the atoms of a metal chain they may be likened to a chain of buckets as they are passed along a chain of persons at a fire. As they proceed down the whole of the matter conveying them can be deflected by a magnet.

The discovery of the true nature of the cathode rays and the existence of electrons or particles of electricity, has made electric conduction and electric action generally much more definite than before.

Reflection of Cathode Rays.—This is not reflection as understood in optics. It is called diffused reflection of the cathode rays. When cathode rays strike the surface either of a conductor or an insulator, cathode rays start from the surface in all directions. All the rays then proceeding from a surface struck by cathode rays are called reflected.

Magnetic Effects of Cathode Rays.—By the luminosity produced in this way their path, ordinarily a straight line, becomes curved when exposed to the action of a magnet. A practical application of this fact is made in electrical engineering in the study of rapidly changing magnetic forces. Ordinary magnets are too heavy to follow the vagaries of the magnetic course, but the cathode rays, having practically no mass, are able to follow the changes in the force no matter how rapid they may be. By watching the movements of the rays the behavior of this course can be deduced.

Magnetic Spectrum of Cathode Rays.—When cathode rays are produced by an induction coil which gives a discontinuous discharge the phosphorescence is broken up into several distinct patches by a magnetic field. For example, if originally there is a narrow straight band of phosphorescence, under the influence of a magnetic field several bright bands of phosphorescence separated by dark spaces are observed. This is the magnetic spectrum of cathode rays, when not produced by mechanisms which have a continuous E. M. F., as an electro-static machine or a storage battery.<sup>1</sup>

Repulsion of Cathode Stream.—When there are two cathodes in a vacuum tube connected together, the cathodic rays from one cathode are deflected when they pass through the dark space surrounding the other cathode. This is to be explained by the electrostatic repulsion of the negative electricity travelling along the cathode rays, by the strong electric field which surrounds it.

Canalstrahlen or Positive Rays.—The Canalstrahlen were observed experimentally when a perforated cathode was used. Under these conditions, if the pressure was between certain limits, luminous streams were observed passing through the holes in the cathode, travelling in straight lines and emerging on the side of the cathode remote from the anode.

These excite phosphorescence on the part of the glass

---

<sup>1</sup>Strutt: Phil. Med. Mag., Vol. XLVIII., p. 478, 1899. Quoted by Thomson.

upon which they strike. If the glass is soda-glass, sodium lines will be observed spectroscopically. When they strike a copper plate they oxidize it. This is not due to the impact of the rays, but is an indirect effect due to the rays producing active oxygen when they pass through the gas. They do not exert this reducing effect through hydrogen. The Canalstrahlen consist of positively charged particles. There is thus a stream of positively charged molecules moving toward the cathode, causing this to emit cathode rays. When the cathode is perforated a part of the stream passes through the holes, producing in the gas behind the cathode luminosity, thus forming the Canalstrahlen. This explanation of Thomson, although not given as sufficiently established, is, however, regarded as the correct one.

The velocity of the positive ions is very much smaller than that of the cathode rays measured, while the proportion of electric charge to the mass is only about  $1/30000$  of the value of a negative ion. It is the same as the value of an electric charge to the mass in the ordinary electrolysis of solutions.

The sun, and probably any luminous star, may be regarded as a source of negatively electrified particles which stream through the solar and stellar systems. When corpuscles moving at a high speed pass through a gas they make it luminous; then when the corpuscles from the sun meet the upper region of the earth's atmosphere they will produce luminous effects. This is the belief of many astrophysicists. If it be assumed that the aurora borealis is caused by corpuscles from the sun passing through the upper regions of the air, its many periodic variations can be explained satisfactorily.

### Alpha, Beta and Gamma Rays.

In the sensitiveness of the electroscope to radiations of many kinds radio-active substances were discovered. These are considered at length in their appropriate place.

The emanations from radium are divided into three groups, the alpha, beta, and gamma.

The alpha group consists of emanations not affected by a strong magnetic field, incapable of passing through any but the thinnest material obstruction.

They are the positively electrified atoms, and their mass is enormous as compared with that of the next group.

The beta rays are cathode rays given off from radium at a very high rate of speed, two-thirds that of light. The gamma rays find their counterpart in the Roentgen ray.

In all these manifestations of light, radiant heat, brush discharges, visible light, ultra-violet rays, cathode rays, N rays and X rays, the physician has an interest as well as the physicist.

Electric waves	Un-known	Infra-red	Red	Orange	Yellow	Green	Blue	Violet	Ultra-violet	Hyper-ultra-violet	Roentgen rays
----------------	----------	-----------	-----	--------	--------	-------	------	--------	--------------	--------------------	---------------

## CHAPTER II.

The Physics of Light Energy and Radiant Heat. Sunlight, Electric Arc Light, Incandescent Light, Mercury Vapor Light, Spark and Vacuum Tube Discharges.

### The Physics of Light.

The purpose of this chapter is to present the physics of light as it bears upon its therapeutic uses. It is possible that the limit may have been exceeded, and it is probable that it falls short of much that the student desires to know. These fundamental facts are to be found in every text-book on physics with illustrative diagrams, to which the reader is directed for further investigation.<sup>1</sup>

The physics of incandescent light, ultra-violet light, and fluorescence are considered in detail in the chapters devoted to those subjects rather than in this connection. The mercury vapor lamp gives a powerful chemical light, but owing to its size and shape does not lend itself to therapeutic work. It is briefly considered, however, at the close of this chapter.

Analogy between Sound and Light.—The analogy between sound and light is a very close one. The intensity of a sound is greater as the amplitude of the vibration of each particle of the air is greater, and the intensity of the light is greater as the amplitude of the vibration of the air is greater. The shorter the undulations producing the sound, the more acute it is, or in other words the more

---

<sup>1</sup>Standard text-books on Physics, Ganot and Daniell.

vibrations there are to the second. Similarly the color of light, or for that matter the invisible waves of light as well, is different according to the length of the undulation producing the light. Red light, for example, is due to a comparatively long undulation and corresponds to a deep sound, while a violet light is due to a short undulation and corresponds to an acute sound.

Perception of Light by the Retina.—The vibrations of the frequencies of the spectrum are perceived by the retina only within distinct limits. If a beam of white light, from the sun, for example, be transmitted through a prism, the light rays are refracted and dispersed, and a prismatic spectrum is obtained. White light when transmitted through a shutter into a dark room and permitted to fall on a screen will form a spectrum, assuming a definite order, i.e., from the least refrangible red to the most refrangible violet.

White light contains, therefore, all the frequencies of the spectrum, the dark or infra-red waves are refracted least, and do not act upon the retina, and are, therefore, invisible. They act, however, upon sensory nerves, and give rise to the sensation of heat. From Fraunhofer's line, A, onward, the oscillations of light affect the retina in the following order and constitute the visible spectrum: red with 481 billions per second, orange with 532, yellow with 563, green with 607, blue with 653, indigo with 676, and violet with 764 billions per second.

The sensation of color, therefore, depends upon the number of vibrations of the light ether, just as the pitch of a note depends upon the number of vibrations of the sounding body. The number of vibrations for each color is constant. There is no color on earth, all colors are in the light, and they manifest themselves as one color or another according to the objects upon which they fall. To perceive a color it is essential that a certain amount of light fall upon the retina. At the lowest degree of brightness, blue gives a color sensation with an amount of light 16 times less than

required for red. White light of different periods of vibration or frequency applied to the eye excites the different sensations of color, the amplitude of the vibrations, height of the waves, or distance of the swing of the oscillating corpuscles from the imaginary line called a ray, determine the intensity of the impression of light, just as the loudness of a note depends upon the amplitude of the vibrations of the sounding body. When all the frequencies fall simultaneously upon the retina, the sensation of white is experienced.

By reuniting the colors of the spectrum obtained by prisms white light is again obtained. If none of the vibrations of light reach the retina, there is what may be termed an absence of sensation of light and color, rather than blackness.<sup>1</sup>

Light Propagated in a Straight Line.—While the propagation of light is always regarded as in an absolutely straight line in a homogeneous medium, the oscillating particles of different rates and length of swing really form curves sinusoidal in character, and if, represented graphically, a single ray of it could be obtained, would practically be that of a sine. The length of the wave is from crest to crest.

The oscillating or swinging corpuscles which represent the vibrations of light are at right angles to the hypothetical line known as ray. With increasing frequency of these oscillations the amplitude of the curves becomes less and the waves shorter. For example, in the same length of ray, a centimetre, a greater number will be contained. A single ray cannot be obtained alone, however, but only pencils consisting of a number of rays.

Parallel, Divergent and Convergent Rays.—If these are at a great distance from the source of light, and the vibrations are very small, they will be parallel. This "luminous pencil," or beam, is, therefore, said to be parallel when it is

---

<sup>1</sup>Landois and Stirling, p. 982.

composed of parallel rays; divergent, when the rays separate from each other; and convergent, when they tend toward the same point.

The effect of color is produced in the eye by the varying frequencies of the vibrations. For each color the number of vibrations is constant, but in a given medium the wave length differs.

Velocity of Light.—Light moves with such a velocity that at the surface of the earth there is, to ordinary observation, no appreciable interval between the occurrence of any luminous phenomenon and its perception by the eye.

The Transmission of Light Rays.—Through the free ether in a vacuum, and almost equally so in air, light rays are transmitted with equal velocity. The number of vibrations are, therefore, small or great in proportion as the waves are long or short.

The velocity of light is estimated at 190,000 miles, 300,000 kilometres per second, or 30,000,000,000 centimetres per second.<sup>1</sup>

The stars nearest the earth are separated from it by at least 206,265 times the distance of the sun; therefore, the light which they send requires more than three years to reach us.

The visible frequencies are to be found between 763 and 395 billions per second, quite generally given as 760 to 390 billions per second.

Light Intensity and its Laws.—By intensity of illumination is understood the quantity of light received on the unit of surface.

The intensity of light is governed by the following laws:

(1) The intensity of illumination on a given surface due to a point surface of light is inversely as the square is the distance from the source. By doubling the distance the strength of the light is diminished to one-fourth. If it be increased threefold the strength of light is one-ninth. If

---

<sup>1</sup>Landauer.



the distance be increased four times, the strength of this source of light must be multiplied by 16 in order to gain an equally powerful illumination.

When the effective light rays strike a surface at right angles, the most powerful illumination takes place.

When the illumination is oblique fewer rays fall on the same plane; some of the rays naturally are longer, and, therefore, when they strike the plane, they are also feebler.

The brightness of illuminating bodies depends on their distance from the source of light, and on their position in relation to it as well as upon the intensity of light in each single point, and on the size of the illuminating plane.

(2) The intensity of illumination which is received obliquely is proportional to the cosine of the angle which the luminous ray makes with the normal to the illuminated surface.<sup>1</sup>

It is owing to the divergence of the luminous rays emitted from the same source that the intensity of the light is inversely as the square of the distance. The illumination of a surface placed in a beam of parallel luminous rays is the same at all distances in a vacuum. In air and other transparent media the intensity of light decreases in consequence of absorption more rapidly than the square of the distance. The law of the cosine applies to rays emitted obliquely by a luminous source; that is, the rays are less intense in proportion as they are more inclined to the surface which emits them. They correspond in this respect to the third law of radiant heat.

Light Standards.—There is no absolute unit of either physical or physiological light. There are, however, certain standard sources of light, the intensity of whose light is taken as unity. (1) The British Standard Sperm Candle burning at the rate of two grains per minute. (2) The Vernon-Harcourt-Pentane Standard, in which

---

<sup>1</sup>Ganot's Physics.

a gas flame of a given height, observed through an opening of definite size, consumes pentane, a variety of coal oil. (3) The Carcel Colza-Oil Lamp, burning 32 grammes of pure Colza oil per hour at a flame height of 40 millimetres. (4) The Hefner Altneck Amyl-Acetate Lamp, in which the flame stands at an elevation of 40 millimetres. The latter is generally known as the German unit, the first as the English unit and the third as the French unit. There are also the Violle Standard Platinum Lamp and the Reichsanstalt Standard, the one depending upon the light emitted by one square of platinum at the temperature of solidification and the other upon the light emitted from a square centimetre of platinum at a definite high temperature.<sup>1</sup>

The eye is not sufficiently accurate to estimate even approximately the relative brightness of the illuminating planes, or in the event of varying intensity of two given points from the same source. For this purpose photometers are used.

Photometers.—By a photometer is understood an apparatus for measuring the relative illuminating powers of different sources of light. With the rays falling perpendicularly upon a unit area, the illuminating power of a source of light is the quantity received by the unit area at unit distance from the source.

Bunsen's Photometer.—The principle of this photometer depends upon the fact that when a grease spot is made on a piece of bibulous paper, if the paper be illuminated by a light placed in front, the spot appears darker than the surrounding space; if, on the contrary, it be illuminated from behind, the spot appears light on a dark ground; if the grease spot and the rest appear unchanged, the illumination on both sides is the same.

With different light intensities this result is obtained by leaving the one stationary and moving the other nearer

---

<sup>1</sup>Houston and Kennelly: Electric Arc Lighting.

or farther away, when a point will be reached at which the grease spot will become invisible because it will then appear as bright as the surrounding paper.

By measuring the distance of the light from the screen by means of a scale, their relative illuminating powers are respectively as the squares of their distance.

To make these photometric measurements, light of a certain intensity, varying in different countries, as has been quoted, is used as a standard.

Rumford's Photometer.—This consists of a ground-glass screen, in front of which is fixed an opaque rod. The lights to be compared, a lamp and a candle, for example, are placed at a certain distance in such a manner that each projects on the screen a shadow of the rod. These shadows are at first of unequal intensity, but by altering the position of the lamp, the latter may be so placed that the intensity of the two shadows is the same. Then since the shadow thrown by the lamp is illuminated by the candle, and that thrown by the candle is illuminated by the lamp, the illumination of the screen, due to each source of light, is the same. The illuminating power of the two sources, that is, the illumination which they would give at equal distance, is then directly proportional to the squares of their distances from the shadows. Or, in other words, if the lamp is three times the distance of the candle, its illuminating power is nine times as great.

There are quite a number of other photometers with which the reader may familiarize himself by reference to standard books on physics.

Measurement of Light by the Actinometer.—In the actinometer, an instrument is to be had for the measurement of light. That light may be used systematically in order to secure a uniformity of usage, precise dosage is necessary.

The principle of the actinometer involves the play of the rays of light upon a platino-cyanide of barium screen, and then determining the thickness of a solution of ammoniated

sulphate of copper necessary to cut off the chemical frequencies.

It is composed of a little black chamber in brass of cubical form. There is a circular orifice on the anterior part closed by a disc of quartz, which permits the entrance of the violet and ultra-violet light. On the posterior part there is cemented a tube of crystal in which glides, drawn by a rack, a tube of brass closed in its anterior portion by a plate of quartz. This plate is covered on the face that looks toward the interior half with platino-cyanide and half with an absolutely opaque black varnish. A standard solution of ammoniacal sulphate is turned into the apparatus. If this actinometer is directed toward a luminous source, then with a convenient thickness of the absorbent liquid, the luminosity of the half the quartz plate covered with platino-cyanide, which had become fluorescent, disappears. From the thickness of the ammoniated sulphate-of-copper solution necessary to obtain this result, the chemical power of the light source is estimated.

Superimposed strips of sensitive paper are also used to measure chemical light intensity, and observations are taken of the progress of the photographic effect.

Larsen<sup>1</sup> measured the blackening of chloride-of-silver paper as the light passes through.

By adding certain coloring matters to the bromide-of-silver paper they may be rendered sensitive to frequencies of other regions than the blue violet and ultra-violet. This is the case with rhodamin, as shown by Andresen, which is sensitive to yellow light; the bromide of silver remains very sensitive to blue violet, but this is counteracted by the use of yellow filters. The sensitiveness of Andresen's rhodamin—bromide-of-silver paper, as well as of other papers, was proved by Eder in a series of experiments. These showed that certain photometer papers are affected by the different regions of the spectrum, according as they are exposed to a

---

<sup>1</sup>Quoted by Freund.

more or less strong light. It is necessary to take into account the concentration and quality of the filtering color used to exclude the blue and violet rays—which become effective with long exposures.

Then again there are electric photometers based on a peculiar property of selenium.

As ultra-violet rays favor the formation of an electric spark, this property has been utilized for the construction of what Larsen, whose device it is, termed an actinoscope. The spark of a static machine or a Rhumkorff coil will cross a longer spark gap if the negative terminal be exposed to ultra-violet energy.

Reflection.—When a ray of light meets a polished surface, it is reflected according to the two following laws:<sup>1</sup>

I. The angle of reflection is equal to the angle of incidence.

II. The incident and the reflected ray are both in the same plane, which is perpendicular to the reflecting surface.

The light which falls on a rough non-luminous body is partly absorbed or transmitted, and the remainder which is thrown back on all sides, makes the object visible. With smooth polished surfaces, however, mirrors, for example, the light is only reflected in certain definite directions. By sufficiently smooth is meant a surface the ridges or scratches of which are decidedly smaller than the wave lengths of light. If they are less than one-quarter of the wave length (less than  $1/200000$  of an inch) they do not cause any breaking up of the waves, and optically are considered quite smooth. Mirrors are polished by scratching them all over with a very fine powder, which makes scratches finer than  $1/200000$  of an inch. The perpendicular produced at the point of the reflecting surface where the ray impinges is in the same plane as the incident and reflected ray, and both form identical angles with it.

---

<sup>1</sup>Ganot's Physics.

Mirrors in connection with the use of light concern the therapist, as they are used with various light mechanism to reflect the light either (1) directly upon the lenses of light-condensing apparatus, or (2) directly upon the surface of the patient's nude body. They are divided according to their shape into plane, spherical (concave and convex), parabolic, conical, etc.

Rays of light which diverge from any point of an object and fall upon a mirror are caused either to converge to, or to appear to diverge from a second point. In either case the second point is called the image of the first point.

Plane Mirrors.—The images of objects in plane mirrors are always exactly opposite the objects, and each is as far behind the mirror as the object is in front. The action is different with curved mirrors, concave and convex.

Concave Mirrors.—A concave mirror, spherical shape, curved and polished on the inside, may produce a real convergence to a point. For example, light reflected upon a concave mirror will converge upon a point in mid air, and that point is the focus. Were it convex instead of concave, the impingement of light waves upon it and their reflection would cause a divergence of the waves. There would no longer be a real focus. Light rays falling on a spherically curved concave mirror, so as to pass through the centre of the sphere, are called axis rays. The spherical centre is called the centre of curvature, and the straight line passing through this point and the curve centre of the mirror itself is the optical axis of the mirror. Axis rays are reflected back directly. The sun's rays coming from an infinite distance are reflected in such a manner that all pass through the focus. This is also the burning point. The focus is the point of convergence of all the rays that strike the mirror parallel with the axis. This focus lies on the main axis, and is midway between the mirror centre and the sphere centre. With the approach of the source of light to the mirror, so that its rays are no longer parallel to each other, the focus recedes further and further,

even to infinity. When the source of light is in the focus the reflected rays are then parallel. When the source of light is brought between the focus and the surface of the mirror, they become divergent.

**Parabolic Mirrors.**—Parabolic mirrors are concave mirrors whose surface is generated by the revolution of the arc of the parabola. All rays after reflection meet in the focus of the mirror and conversely, when a source of light is placed in the focus, the rays incident to the mirror are reflected exactly parallel to the axis. The light thus reflected tends to maintain its intensity even at a great distance, as it is the divergence of the luminous rays which principally weakens the intensity of light. It is because of this property that parabolic mirrors are used as projectors in railway trains, carriage lamps, etc.

**The Mangin Mirror.**—This dioptric reflector is a glass mirror of special form. It consists of a spherical mirror whose inner and outer surfaces are of different radii. The outer surface is silvered so that the rays proceeding from the arc pass inward, i.e., to the mirror at the back of the mechanism before being projected outward as parallel rays. This is true of all frequencies of more than 30 micro-centimetres in length. Frequencies of shorter length, i.e., the ultra-violet, do not pass outward through the mirror of glass because of their wave length. This is the mirror provided in the marine searchlight mechanism, described in another chapter.

**Application of Mirrors.**—The application of plane mirrors does not concern us here. Concave mirrors are largely used in therapeutic work: (1) to reflect the light of an arc upon a condensing lens; (2) to reflect the sun's rays or the light of the arc upon the patient's body. Simple concave silvered mirrors are used to reflect the light of the arc in the cabinet devoted to therapeutic work. Concave mirrors serve to concentrate greater quantities of light than can be done with lenses. The mirrors used by Kime for concentrating solar light are of this type. Parabolic mirrors absorb but little light and can be used at suitable focal distances.

Focal Length.—The point of convergence of the parallel rays is the principal focus of the mirror; its distance from the mirror is the focal length.

Refraction.—By refraction is understood the deflection or bending which the rays of light experience in passing obliquely from one medium to another; for example, from air into water. If the incident ray is perpendicular to the surface, separating the two media, it is not bent but continues its course in a straight line. The incident ray is the one which strikes the water, and the refracted ray is the ray that is bent in the second medium, in this instance, the water.

The two angles which these rays form, with a line perpendicular to the surface of the water, separating in this instance the two media, the first between the incident ray and the line normal to the surface is the angle of incidence, and the other formed by the refracting ray and the perpendicular line as it extends into the water, the angle of refraction.

The second medium is more or less refracting than the first, according as the refracting ray approaches or deviates from the normal.

All the light which falls on the surface of a refracting substance does not pass into it completely; one part is reflected regularly or diffusely, while another penetrates into the medium.

In media which are uncrystallized, such as air, liquids, ordinary glass, the luminous ray is singly reflected; but in certain crystallized bodies, such as Iceland spar, selenite, etc., the incident ray gives rise to two refracted rays. This phenomenon is that of double refraction.

The following law prevails when a luminous ray is refracted from one medium into another of different refractive power.

I. Whatever the obliquity of the incident ray, the ratio which the sine of the incident angle bears to the sine of the angle of refraction is constant for the same media and the same colored light, but varies with different media.



If the light passes from a rare to a denser medium, the reflected ray approaches the perpendicular, otherwise it recedes from it. In order that refraction may take place, the incident ray must form an acute angle with the normal; if it form a right angle, it traverses the medium in a straight line. Rays impinging at right angles on the dividing surface of two transparent bodies are more refracted.

Index of Refraction.—By index of refraction is understood the ratio between the sines of the incident and refracted angles, sometimes spoken of as the refractive index, of the second medium with respect to the first.

The respective index varies with the media; for example, from air to water it is 4-3 and from air to glass it is 3-2. If the media are considered in an inverse order, that is, if light passes from water to air instead of air to water, or from glass to air, it follows the same course but in a contrary direction. Therefore, the refractive index is reversed; from water to air it is 3-4, and from glass to water 2-3.

The index of refraction of one medium to another on the undulatory theory of light is the ratio of velocity with which light travels in the second medium to that which it travels in the first. For example, the velocity of light in glass is 2-3, and in water 3-4 of its velocity in empty space. The refractive index depends on the rate of vibrational activity of the light corpuscles or its colors.

The refractive indices of the following substances are for D light and at a temperature of 20°.

Water .....	1.3333
Alcohol .....	1.3616
Carbon sulphide .....	1.6276
<i>a</i> -bromnaphthalene .....	1.6582
Ethyl cinnamate at 18.80.....	1.5607
Common glass .....	1.515 — 1.615
Flint glass.....	1.614 — 1.762
Jena, heaviest silicate flint glass No. 557....	1.9625
Quartz, ordinary ray.....	1.5442
Fluorspar .....	1.4339
Air O° and 760 mm.....	1.0002922

Plates with plane parallel surfaces cause the incident ray to be as much deflected toward the perpendicular as the issuing ray is bent from it; the two rays are, therefore, parallel to one another.

Lenses.—These are transparent media, which from the curvature of their surfaces have the property of causing the luminous rays which traverse them either to converge or diverge. They vary according to their curvature, and are either spherical, cylindrical, elliptical or parabolic. By a combination of their spherical surfaces either with each other or with plane surfaces, the number of different lenses is increased. Of these the double convex, plane convex and concave convex are all converging or convex lenses. They are thicker in the middle than at the edges. Concave lenses are thinner in the centre and thicker at the edges.

In lenses where the surfaces are spherical, the centres for these surfaces are called centres of curvature, and the right line which passes through these two centres is the principal axis. In or near every lens there is a point called the optical centre, which is situated on the axis, and which has the property that any luminous ray passing through it experiences an angular deviation; that is, the emergent ray is parallel to the incident ray.

Rays striking a concave lens parallel with the axis are dispersed after refraction. The axial rays passing through the centre of the lens are not refraction.

Objects viewed through a concave lens appear smaller and nearer.

The images formed by different forms of lenses do not concern us in this connection.

Refraction of Sun's Rays in a Double Convex Lens.—If the sun's rays be allowed to pass through a lens convex on both sides, they are refracted so as to converge as one point of light at a certain distance from the lens, dependent upon the focal length of the lens. If a piece of paper or wood be held at this converging point or focus, it will become heated and finally ignite. This is the principle of the

burning glass referred to under the physics of radiant heat. The convex lens acts, therefore, as a burning glass.

Refraction of Light Rays Parallel with the Axis by Convex Lenses.—When light rays impinge on a convex lens, parallel with the axis of the lens, they are so refracted that all of them pass through the focus.

Focal Rays in Relation to Convex Lenses.—When light rays have passed through a focus and then impinge upon a convex lens they become after refraction parallel with the axis of the lens. The axial rays pass through without refraction.

The Focal Length of a Lens and the Nature of the Refractive Index of its Material.—By focal distance is understood the distance of the focus from the centre of the lens.

Both of these factors enter into the construction of lenses to be used in connection with sources of light energy in therapeutic work. Both are determined mathematically. The transparency of quartz to the frequencies of the ultra-violet region is dependent upon the nature of its refraction.

The Effect of Lenses Dependent upon Their Diameter, Curve and Refractive Power of Their Substance.—The diameter and curve of lenses govern their effect as does also the refractive power of the substance from which they are cut. For example, glass or quartz.

Spherical Aberration and Chromatic Aberration.—When parallel rays strike a spherical lens close to the edge, they do not converge in one focus after reflection, but spread over a wider zone, whose axis is the focal line proper. The same is true of large spherical mirrors. To this phenomenon is given the name of spherical aberration. Its effect is to blur the image. It is especially prone to occur with thick lenses.

Lenses are also subject to chromatic aberration. As the term implies, they break up white light into its component parts, as does a prism. If a bundle of rays be thrown on a convex lens parallel to the optical axis, the violet rays which

are refracted at the sharper angles will intersect each other behind the lens at a shorter distance from it than the other rays, the longer, slower and less refrangible red will intersect at the greatest distance. At whatever point the image is caught but one color stands out distinctly, all the others are blurred.

Reflection and Refraction.—Both of these phenomena are of concern in the therapeutic uses of light. The impinging light is not reflected. A part finds its way into the second medium. This means that there is a certain loss of light. The amount of loss by reflection depends (1) on the nature of the media; (2) on the direction of the rays.

Refraction is seen in all its beauty in the diamond, in cut glass and in the prismatic pendants from cut glass.

Transformation of Refracted Light Energy.—All of the refracted light does not pass through the second medium. A part is used up in it and is converted into other forms of energy; for instance, heat, chemical energy, etc.

Reflected Light of Less Candle-power than Incident Light.—If the total strength of the light reflected by a body and that which passes through it be measured photometrically, it will be found to be less than that of the impinging light.

Prisms in Relation to the Decomposition of White Light.—If a beam of light pass through a prism it is diverted from its original direction and resolved into its component colors. There appear the colors of the spectrum, red, orange, yellow, green, blue, violet. These colors are not of sharp definition but merge insensibly into one another.

Dispersion.—Reflection not only changes the direction of a ray of light, but if it is not homogeneous, its nature is also modified; a ray of light is converted into a rainbow-colored band, as may easily be seen by the help of a prism. The many colored light rays are transmitted with uniform velocity in a vacuum, but in a denser medium the more rapidly vibrating violet rays undergo a greater retardation than the red rays which vibrate more slowly; the former,

therefore, are refracted more strongly than the latter. Passage through a second prism more strongly refracts the component rays but they are not decomposed any further; they are therefore simple and homogeneous and if combined by means of a lens white light is again produced.

Abnormal Dispersion.—As a rule the refractive index of a medium is greater the smaller the wave length of the particular light; in the visible spectrum the index steadily increases in passing from red to blue. There are substances which do not conform to this rule. Their solutions when employed as refracting and dispersing agents exhibit the inverse relationship between refractive index and dispersion. To this phenomenon is given the name of Abnormal Dispersion.

Luminous, Transparent, Translucent and Opaque Bodies.—Bodies are luminous when they emit light, the sun, and electric arc and incandescent solid or filament, for example.

Transparent Bodies.—Bodies which readily transmit light, as water, polished glass, gases permitting objects to be distinguished through them, are transparent or diaphanous.

Translucent Bodies.—Those bodies which permit the passage of light without the ability to distinguish objects are translucent. This is true of ground glass, oil paper, milk, blood, etc., and also of the more superficial parts of the living organism, such as the ear, hand, and even deeper tissues. This translucency of the living tissue, i.e., the blood to light, is availed of as an aid to diagnosis. Under all conditions it is due to the incorporation of foreign particles from which the light is diffusely reflected.

Opaque Bodies.—Bodies which do not transmit light, as wood, metals, are said to be opaque. Their opacity depends upon the thickness of their substance. No bodies can be said to be opaque, for if cut sufficiently thin, they are all more or less translucent. For example, the object glass of a telescope thinly silvered is so transparent that the sun may be viewed through it without danger to the eye, as the metallic surface reflects the greater part of the radiation which falls upon it. On the other hand, no body can be said

to be absolutely transparent. There would be no absorption in such a case.

Different media transmit different wave lengths. For example, glass which is transparent to light is not transparent to ultra-violet light.

Physical Condition of the Sun.—As an explanation of the occurrence of the dark lines in the solar spectrum, Kirchhoff concluded that the atmosphere of the sun encloses a luminous mass which emits a continuous spectrum of high illuminating power. This inner portion is either solid or liquid, and at a higher temperature than the atmosphere. Subsequent and more recent investigations, however, show that the sun is much more complex than Kirchhoff imagined. The nature of the *inner nucleus* of the sun can only be conjectured, as it is beyond the reach of observation. In all probability it consists of a gas at an extremely high temperature, and under such an enormous pressure that its properties must resemble to some extent those of a viscous substance, like putty. Surrounding this nucleus is the *photosphere*, composed of glowing cloud-like masses of vapor; it forms the visible surface and appears to correspond with the clouds in the terrestrial atmosphere. It is unknown whether it is separated from the nucleus by a definite surface. Externally, it is sharply but irregularly confined, being elevated in some places into *faculae*, and in others depressed, forming *spots*. The *reversing layer* is situated directly over the photosphere and produces the Fraunhofer lines. Its thickness is only about 1,000 miles. The gases composing the reversing layer are not confined exclusively to the surface of the photosphere. They also occupy the spaces between the photospheric clouds and constitute the atmosphere in which these float. Above the reversing layer is the scarlet red chromosphere, consisting of uncondensed gases,—hydrogen and helium. Numerous prominences extend from this far beyond the surface of the sun. The exterior portion of the sun is termed the corona, it consists of clouds and irregular streams of light and

gradually merges into the surrounding darkness. The greater portion of the mass of the sun is within the photosphere, but the larger part of its volume is outside of it. The diameter of the solar atmosphere is at least double that of the central portion, and its volume consequently seven times as great as this. In the fact that the atmosphere of the nucleus of the sun is an atmosphere sufficient to volatilize metals, and also that the sun's mean density is low, there is found sufficient evidence for the belief that the nucleus of the sun consists of gas. As the temperature of the gaseous mass is far above its critical point, the high pressure must cause it to exceed water in density, and, therefore, the gases must be viscous and comparable in properties with molten glass or putty. The photosphere is undoubtedly a gaseous envelope, condensed in places into cloud-like masses of vapor in consequence of the heat radiating into space. These masses account for its irregular appearance, and the solid or liquid particles of them cause luminosity and produce a continuous spectrum, like the solid particles in an ordinary flame.

The spectrum of the sun spots exhibits a number of dark bands; the dark lines of calcium, iron, titanium, etc., are widened, the hydrogen lines are reversed, and the sodium lines are also frequently enormously widened and doubly reversed. These phenomena render it likely that the increased absorption is due to gases and vapors rushing in to fill a space and absorbing the light emitted from the cavity. Lines are sometimes displaced in consequence of violent motion of the gases. The faculæ show a reversal of the H and K bands of calcium, by a thin bright line running down the middle of each, and, whilst the reversal over a spot is generally "single" the bright line is usually "double" in the faculous region surrounding it. From this it is thought probable that the faculæ are not mere protrusions from the photosphere, but luminous masses of calcium vapor floating in the solar atmosphere and possibly identical with the prominences themselves.

The emission spectrum of the reversing layer, the cause of the Fraunhofer dark lines, can only be observed during a total eclipse; at the moment when the sun is completely obscured by the moon, the lines of the whole spectrum are seen to flash out brightly luminous.

The infrequent occurrence of this phenomenon commands the attention of the spectroscopist wherever he may be and astronomical expeditions journey to the ends of the earth to witness it.

This flashing spectrum was first seen by Young at the total eclipse of the sun in Spain on December 22, 1870. The moon had almost hidden the sun, the black lines were still visible, but at the exact moment when totality occurred, he saw the black lines disappear and "all at once, as suddenly as a bursting rocket shoots out its stars, the whole field of view was filled with more numerous bright lines than one could count."<sup>1</sup>

The Chromosphere and its Prominences.—A spectroscope of high dispersive power, the slit widely open, permits a study of the spectra of the chromosphere and a view of the whole prominence if not too large. The prominences appear to bear a certain relationship to the sun's spots and faculæ; they are divided into two classes, quiescent, cloudlike, or hydrogen and helium prominences, and eruptive or metallic ones. The former resemble terrestrial clouds in appearance; the latter are highly luminous, but the degree of luminosity and the shape change with extreme rapidity. Their spectra are very complicated.

The Corona.—Much uncertainty prevails as to the nature of the corona. It is only visible during a total eclipse. The spectrum presents a double line in the green region 1,474 K. of wave lengths 5,316.87.

One of these lines is supposed to be due to iron as it coincides end to end with an absorption black line in the spectrum of the sun's surface far below. The other does

---

<sup>1</sup>Young.



not coincide with the line of any mode of matter yet found on earth. The substance is named coronium and awaits identification. The most plentiful gas in the corona is hydrogen. Calcium also is present, and thus far about 30 substances have been identified by means of their lines.

It is now generally admitted that the corona consists of an atmosphere extending 300,000 miles and of extreme tenacity.

It is as yet uncertain as to the true nature of the coronal streamers.<sup>1</sup> They are regarded as a permanent aurora, their position and direction being determined by the sun's magnetic field of force as the terrestrial field of force direct the beams of the aurora borealis; again they are believed to be due to light emitted and reflected from streams of matter ejected from the sun by forces acting in general, along lines normal to the surface of the sun, and most active near the centre of each sun-spot zone.

### Radiant Heat.

Heat is not transmitted by the intervening air. For example, if one stands at a little distance from the fire or other source of heat a sensation of warmth is produced. This is not due to the temperature of the air, for if a screen be interposed the sensation immediately disappears. This would not be the case if the surrounding air had a high temperature. Just so the heat from the sun reaches us, that is it is transmitted to the body from the source of heat without affecting the temperature of the intervening medium. It is said, therefore, to be radiated. Take a hollow glass lens through which cold water is allowed to flow in a constant stream, and yet the solar rays concentrated by this arrangement will light a piece of wood placed in focus. Heat is also conducted as, for example, when the end of a metal bar is heated, a certain increase of temperature is presently observed along the bar. In this discussion of the subject,

---

<sup>1</sup>Landauer: Spectrum Analysis, pp. 203-207.

however, it is radiant heat which concerns us, the heat radiated from the sun or from a source of artificial light, the ordinary incandescent lamp, for example.

These bodies, therefore, send out rays capable of exciting the phenomena of heat, and these heat radiations (invisible light rays) penetrate the air without heating it, as rays of light through transparent bodies. The terms rays of heat, calorific rays or, as the author prefers, in discussing heat from radiant sources, thermal frequencies, are used in the same sense as ray of light, luminous rays, or visible light frequencies. Bodies of all temperatures have the power of radiating heat, nor is it necessary that they should be luminous as a fire or red hot ball. From bodies of sufficient temperature, heat radiations proceed which may be termed luminous, from others obscure heat. The brightly glowing anthracite fire emits luminous heat rays, the steam radiator obscure rays.

Measurement of Radiant Heat.—The presence of radiant heat may be readily detected by the use of Melloni's thermomultiplier, which is a thermopile, connected with a delicate galvanometer. With this apparatus Melloni was able to measure differences of temperature of  $1/5000$  of a degree. A more sensitive apparatus is that of C. V. Boy's radio-micrometer, which enables the detection of differences of temperature of  $1/1000000$  of a C.<sup>o</sup>

Radiation of heat is governed by the following laws:<sup>1</sup>

I. Radiation takes place in all directions from a body. It does not matter in what direction in relation to a heated body a thermometer be placed, a rise in temperature from every point is indicated.

II. In a homogeneous medium, radiation takes place in a right line. If a screen be placed in the right line which joins the source of heat and the thermometer, the latter is not affected. But in passing obliquely, however, from one medium into another, as from air into glass, the thermal rays

---

<sup>1</sup>Ganot's Physics, pp. 408, 409.

or frequencies are deviated the same as luminous rays or frequencies. This effect is known as refraction, and is fully considered under the head of refraction of light.

III. Radiant heat is propagated in vacuo as well as in air. Fix a thermometer in the bottom of a glass flask, so that its bulb occupies the centre of the flask. By the use of the blowpipe the neck of the flask is carefully narrowed, and by the air pump the interior is exhausted to a proper degree of vacuum and then sealed. If the apparatus then be immersed in hot water, or brought near hot charcoal, the mercury in the thermometer at once rises. As glass is a bad conductor, the heat rays could not travel so rapidly through the sides of the flask and the thermometer, therefore the increase of temperature must be by radiation through the vacuum. This phenomenon is daily seen in X ray tubes and vacuum tubes excited by electric sources.

Causes which Modify the Intensity of Radiant Heat.—There is understood by the intensity of radiant heat, at a particular place, the quantity of heat received on the unit of surface at that place. This intensity may be modified by (1) the temperature of the source of heat, (2) its distance, and (3) the obliquity of the calorific rays in reference to the surface which emits them. These modifications are regulated by the following laws:

I. The intensity of radiant heat is proportioned to the temperature of the source.

II. The intensity is inversely as the square of the distance from the source.

III. The intensity is less the greater the obliquity of the rays with respect to the radiating surface.

The first law is so self-evident as not to need demonstration, still if a metal box filled with water at  $10^{\circ}$ ,  $20^{\circ}$  or  $30^{\circ}$  be placed successively at equal distances from a differential thermometer, the temperatures indicated by the latter (5) will be found to be in the same ratio as the box; for example, if the temperature of the thermometer corresponding to the

box at  $10^\circ$  indicates  $2^\circ$ , then that of the others will be  $4^\circ$  and  $6^\circ$  respectively.

The second law follows from the geometrical principle that the surface of a sphere increases as the square of its radius. Take a hollow sphere of any given radius, place a source of heat in the centre, each unit of surface in the interior receives a certain quantity of heat; now if the sphere of double the radius be used, a surface four times as great will be presented to the source of radiating heat; the internal surface will, therefore, contain four times as many units of surface, and as the quantity of heat emitted is the same, each unit of surface will receive one-fourth the amount.

The third modification is of less general applicability. The intensity is always less when the radiating rays are oblique to the radiating surface than where they are perpendicular. Expressed in mathematical formula, it is known as the law of the cosine; i.e., that the intensity of oblique rays is proportional to the cosine of the angle which these rays form with the normal to the surface. This law is not general, however; it has been known to be true only within narrow limits, i.e., with bodies which, like lampblack, are entirely destitute of reflecting power.

Mobile Equilibrium.—*The theory of exchanges suggested* by Prévost, of Geneva, in regard to radiant heat is now generally accepted. All bodies, whatever their temperature, constantly radiate heat in all directions. If two bodies of different temperatures be placed near one another, the one of higher temperature will experience a loss of heat through its emitting radiations greater than it receives; but the one of lower temperature will rise in temperature because it receives an energy of radiation higher than it emits. Both will ultimately come to have the same temperature, but there will still be an exchange of heat radiations between them. As the one does not receive under these physical conditions more than it emits, necessarily an equilibrium of temperature is reached.

This state is known as that of *mobile equilibrium of temperature*.

Reflection of Heat.—The thermal frequencies or rays which fall upon a body are, generally speaking, divided into two portions, one of which penetrates the body while the other rebounds or is repelled from the surface like an elastic ball. This part of the thermal activity is, therefore, reflected, and the reflection of heat rays, like those of light, is governed by the two following laws:

I. The angle of reflection is equal to the angle of incidence.

II. Both the incident and the reflected ray are in the same plane with the perpendicular to the reflecting surface.

The absolute reflecting power at an angle of  $50^\circ$  is for silver plate  $97^\circ$ , gold  $95^\circ$ , brass  $93^\circ$ , platinum  $83^\circ$ , steel  $82^\circ$ , zinc  $81^\circ$ , iron  $77^\circ$ , cast iron  $74^\circ$ . Therefore of the baser metals brass first, steel next and zinc third afford when polished the best reflecting surface for the lining of an incandescent cabinet for example, where the maximum thermal activity is required. Steel would seem to be the most practical substance from every point of view.

Reflection in a Vacuum.—Different conditions obtain in vacuo and in the air, the former being cooled or heated by radiation alone, the latter by contact with the air according as it is cooler or hotter than the radiating body. The quantity of heat gained or lost in a second is governed by the temperature; it is greater according as the difference of temperature is greater.

Burning Mirrors.—From the high temperature produced in the foci of concave mirrors, they have been called burning mirrors. It is stated that Archimedes burnt the Roman vessels before Syracuse by means of such mirrors. Buffon constructed burning mirrors of such power as to prove that the feat attributed to Archimedes was not impossible. The mirrors were made up of silver plane mirrors about 8 inches

long by 5 inches broad. They could be turned independently of each other in such a manner that the rays reflected from each coincided at the same point. With 128 mirrors and a hot summer's sun Buffon ignited a plank of tarred wood at a distance of 70 feet. The concavity of the Mangin mirror at the back of the marine searchlight accounts for the extreme heat of the beam of light proceeding from it, a temperature much beyond that of arcs of the same ampère when not so reflected. The power of throwing off a greater or less proportion of its incident heat, is known as its *reflecting power*, and it varies with different substances. Of the metals, and also other substances, taking brass as the unit at 100, their relative reflecting power is as follows :

Polished brass	100	But their absolute reflecting power is the relation of the quantity of heat reflected to the quantity of heat received.
Silver	90	
Steel	70	
Lead	60	
Indian ink	13	
Glass	10	
Oiled glass	5	
Lampblack	0	

The Absorption of Heat.—Heat, in common with light, is *absorbed*, and the *absorbing power* of a body is its power which permits a greater or less quantity of the heat which falls upon it to pass into its mass. The absolute value of the absorbing power is the ratio of the quantity of heat absorbed to the quantity of heat received. The absorbing power of a body is always inversely as its reflecting surface: a body which is a good absorbent is a bad reflector, and *vice versa*. The sum of the reflected and absorbed heat is always less than the incident heat. The latter is divided into three parts: (1) one which is absorbed, (2) another which is reflected regularly according to the laws for reflection of heat, and (3) which is irregularly reflected in all directions, and which is called *scattered* or *diffused* heat. A part of the heat may also pass through a substance as light passes through glass. Various

substances possess varying powers of heat absorption. The radiating or emissive power of a body is its capability of emitting at the same temperature, and with the same extent of surface, greater or less quantities of heat.

From experimental data the identity of the absorbing and radiating power has been determined.

As they are equal, any cause which affects the one will affect the other as well. Whatever increases the reflecting power diminishes the radiating and absorbing power, and *vice versa*. These different powers vary with different bodies and even in the same bodies, they are modified, for example, by the degree of polish in metals. They are also modified by the density, the thickness of the radiating substance, the obliquity of the incident reflected rays, and lastly, by the manner of the source of heat. Metals have the greatest reflecting power, lampblack the least.<sup>1</sup>

Vibration of the Particles of a Heated Body.—A heated body is to be regarded as one whose particles are in a state of vibration, and the higher the temperature of the body, the more rapid are these vibrations. A diminution in temperature is but a diminution in the rapidity of vibration of the particles. The propagation of heat through a bar is due to a gradual communication of the vibratory motion from the heated part to the rest of the bar. The propagation of this motion of heat vibrations even through the best conductors is comparatively slow. There is a difference in different substances, some transmitting the vibratory motion from particle to particle much more rapidly than others. When a screen is removed from before a fire or the clouds drift away from the face of the sun, the sensation of heat is instantly perceived. Here the heat radiations pass from the one body to the other without affecting the temperature of the space through which it passes. The particles of a heated body being in a state of intensely rapid vibration communicate their motion to the

---

<sup>1</sup>Ganot's Physics, sec. 431, p. 419.

ether around them, the particles of which are set in successive vibration and hence give rise to waves in the ether which travel through space and pass from one body to another with the velocity of light. A ray of heat is merely a series of waves moving in a certain direction. In heated bodies, definite wave lengths are emitted according to its temperature. In other words, its particles vibrate in a certain period. The higher the temperature, the shorter the wave lengths and the more frequent because of the more rapid vibrations, but they coexist, however, with all those previously emitted by the same body. The motion is therefore at each successive temperature a compound of all preceding ones. The carbon filament of an incandescent lamp at a certain temperature, dependent upon the E. M. F. and R. of the current used, becomes dull red, i.e., its particles vibrate at a definite period and there is an emission of slow waves of long length. Bring it to a brighter glow and there are shorter and more frequent waves, while brought to full incandescence means still more rapid vibrational activity of the carbon filament under excitation by the electric current, and therefore waves still shorter and more frequent, but this latter vibrational activity gives not only the shorter and more frequent but all the wave lengths which have preceded it. It is a complex of the whole. So is the radiant energy of the sun and of the electric arc a complex of all the rates of vibrational activity from the lowest to the highest. The optic nerve is insensible to a large number of the wave lengths thus produced, apprehending only those that form the visible spectrum. Though intense motion may pass through the humors of the eye, yet if the undulations of these oscillating corpuscles be lower than the red or higher than the violet yet we shall be entirely unconscious of the fact, for the optic nerve cannot take up and respond to the vibrations which exist beyond the ends of the visible spectrum, either below the red or above the violet. These latter are invisible or obscure rays.

Some flames, that of a Bunsen burner or an oxy-hydrogen flame, emit vast quantities of obscure rays, for their



vibrations though capable in part of penetrating the media of the eye are incapable of exciting the sensation of light in the optic nerve.

### Thermal Analysis of Sunlight.

The sun as a source of radiant heat concerns us first and therefore a thermal analysis of sunlight is called for.

Let a narrow vertical slit be made in the shutter of a dark room and strongly illumined by sunlight and let the light from the slit be focused by a rock-salt lens on a screen and a rock-salt prism suitably placed. The light as it emerges from the prism will be found to present on the screen a band of colors in the following order: red, orange, yellow, green, blue and violet. This constitutes the spectrum, which is more extensively considered under the discussion of light. By placing a narrow delicate thermopile on the space occupied by each of these colors, it will be found to be very little affected on the violet, but a gradual rise of temperature will be noted as it passes over the other colors. Unconsciously and without any knowledge of this physical fact, on the part of the observer, blue and green are spoken of as cold colors, while red and orange are universally recognized as warm tones. If the pile be moved beyond the limits of the luminous or visible spectrum the temperature will gradually rise to a given point where the maximum is obtained. From that to another given point the pile indicates a decrease in temperature. At that point it ceases to be affected. The first point is as far from the second as the second from the third; that is, there is a region in which thermal effects are produced extending considerably beyond the red end of the spectrum. These rays or frequencies represent the different rates of vibration or swing of the oscillating corpuscles. In their passage through the prism, they are unequally broken or refracted; those of the longest wave length or slowest vibrating period are least bent aside, i.e., they are the least refrangible, while the rays of shortest

wave length, most rapid vibrating period, are the most refrangible. In the radiant energy of the sun there is a vast assemblage of superposed waves of different wave lengths. The prism breaks the compound waves into their constituents, the short waves being more refrangible than the long ones. All save the red frequencies and those below will be considered under the visible spectrum. The evidence of the existence of the rays beyond the violet is obtained by their action on silver salts, on fluorescent substances, etc. But it matters not what the radiation or wave length, if it falls on a lampblack surface, it is absorbed by it and converted into heat, the absorption thus measuring the energy of the incident radiation. The energy measured in this way is greatest at the red end of the spectrum and beyond, hence the use of the term heat rays or thermal frequencies, while in contradistinction, the visible frequencies are called the light rays or luminous frequencies, while those beyond the violet are spoken of as the actinic rays. There is but one kind of energy radiated from the sun, the heat, light or chemical effects depend entirely upon the state or condition of the matter upon which the different wave lengths may happen to fall. Langley,<sup>1</sup> to whom photo-physics is indebted for elaborate researches into the previously unknown radiations, especially at the infra-red end of the visible spectrum, states that "up to 1872 it was almost universally believed that there were three different kinds of entities, active, luminous and thermal, represented in the spectrum. There is one radiant energy which appears to us as 'actinic,' 'luminous' or 'thermal' radiation according to the way we observe it. Heat and light then, are not things in themselves, but different sensations in our own bodies, or different effects in other bodies; are merely effects of this mysterious thing we call radiant energy." Over sixty years ago Melloni, an Italian physicist, wrote, "Light is merely a series of calorific indications, sensible to the organs of sight, or *vice versa*, the radia-

---

<sup>1</sup>Proceedings American Association Science, Cleveland Session.

tions of obscure heat are veritable invisible radiations of light." This theory was not adopted until the physical fact had been demonstrated by the researches of Langley which were much more refined and complex than those of other investigators. There is but one radiant energy to the modern physicist as unquestionably it will be agreed that there is only one matter.

Chemical action is not confined to frequencies of short wave length, any more than thermal action is confined to the frequencies of the red region. Under proper conditions the green, red and infra-red frequencies will all produce photographic action. A proof of the chemical action of the red frequencies can be had in the ability to photograph through the human body. At least the inference seems fair, for it is the red frequencies which pass through. The hand photographed by Gebhard had a photographic plate placed in the hollow of the palm. It was then imbedded in plaster of Paris save for the dorsal surface. After 20 minutes' exposure to the light of an electric arc, the plate was subsequently removed to the dark room and developed. It was found to be darkened and the contours of the hand and fingers were distinctly seen, showing that the light had penetrated. Similar experiments have been made by Freund, Strebel, Kime, Gottheil and others. The only physical distinction to be made between light rays, heat rays, and actinic rays is that of wave length. And by reason of the different wave lengths a difference of physical action upon the living organism takes place; it is with different component parts of the structure as it is elsewhere in the physical world, the effects are those of heat, light, or chemical action according to the state or condition of matter upon which the energy from the sun or an artificial source is radiated.

Radiation does not leave the sun either as light or heat but as radiant energy. The wave lengths of the radiation lying within certain limits fall upon the eye and they are called light; the same wave lengths will decompose the silver bromide of a photographic plate and hence they are called

actinic rays; while equally well will they raise the temperature of a blackened bulb thermometer, therefore they are heat rays. The short and high frequencies of the vibrational activity of the oscillating light corpuscles are the best adapted to produce chemical action, which is the highest form of vibrational activity.

As prisms of different materials absorb rays of different refrangibility to unequal extents, the maximum heat will be found to vary according to the material used. With the rock salt we have found it to be in the red, with a prism of water it is in the yellow, while with one of crown glass it is in the middle of the red. Rock salt however practically permits the passage of all the frequencies, even the ultra-violet and gives therefore a very normal spectrum. Tyndall showed by his experiments that the heating effects gradually increased from the violet but were greatest in the dark space beyond the red; the position being about as far from the visible red as the latter was from the green, and the total extent of the invisible spectrum was found to be twice that of the visible. The visible part of the sun's radiance is only a small fraction of the output.

Langley, to whom we are indebted for the longest wave length, devised a very sensitive instrument known as a bolometer,<sup>1</sup> or actinic balance, by means of which he explored farther and farther into the long heat wave region, using prisms of rock salt, because this substance permits the passage of more heat than any other known. Professor Langley's new bolometer is the most sensitive instrument ever constructed. In the Smithsonian report of 1900, appears a plate showing the long infra-red or new spectrum, which is thirteen times the length of the spectrum which makes impress upon the eye. In it are to be seen wide dark bands as in the visible spectrum. They indicate absorption of course, as absorption is the cause of all dark and cold spaces in the solar spectrum, but it is not known what modes of matter caused them.

---

<sup>1</sup>For description see Ganot's Physics, sec. 932, 16th edition.

In the thermal end of the spectrum are waves of varying intensities, showing that the energy of the sun is uneven in its distribution. Langley's bolometer detects the lines and bands of this end of the spectrum by means of their temperature. Cold in the bolometer spectrum has the same significance as darkness in the visible spectrum and these dark lines vary greatly in width—just as do those of the visible spectrum. These long slow waves are difficult of recording graphically, and are not even comparable in this respect with the waves constantly issuing from radium, by means of which a much stronger impression is made upon a sensitive plate. But as has been shown heat is not confined to this region as the frequencies of the visible spectrum also give off a great deal of heat, therefore the quantity of light is extremely small, and the investigator in his attempt to devise a means for artificial illumination deficient in heat is, after all, seeking that which nature has not provided in the radiant energy of the sun.

Langley used in his investigations of the heat end of the spectrum a Rowland grating<sup>1</sup> so as to avoid effects due to the absorption and measured the heat by means of his bolometer which showed difference in temperature of  $0.00001^{\circ}$  F. According to Ganot there was obtained in this way an invisible spectrum extending beyond the red to 20 times the length of the visible spectrum. The absorption of the radiation by the bolometer begins to be measured just outside the violet at a wave length of about  $0.25\mu$  and is at a maximum at a wave length of  $0.65\mu$ . The depressions shown in the curve represent the dark lines or what is known as Fraunhofer's lines.<sup>2</sup>

If a solar spectrum could be produced outside the atmosphere it would probably give a spectrum more like that of the electric light, which is unaffected by the atmospheric absorption. Flint-glass prisms and especially water will absorb the infra or called sometimes the ultra-red radiations.

---

<sup>1</sup>See description, Ganot's Physics, sec. 662.

<sup>2</sup>Original paper, Phil. Mag. (V.) Vol. 26, p. 505.

The absorption in the atmosphere has always been attributed to the aqueous vapor, but according to Cornu<sup>1</sup> it is absorbed by the oxygen and nitrogen of the air.

The thermal frequencies from bodies heated under incandescence are all absorbed when the beam is passed through a solution of alum in water. Rock salt permits the passage of both the luminous and the obscure radiation. A solution of iodine in carbon bisulphide, which Tyndall found to be impervious to the brightest light, is very pervious to radiation of great wave length, only a slight absorption being affected by the bisulphide. This means was used in determining the relative proportion of luminous and obscure radiations under different conditions, which were found to be as follows :

Source.	Luminous.	Obscure.
Red hot spiral.....	0 .....	100
Hydrogen flame .....	0 .....	100
Oil flame .....	3 .....	97
Gas flame .....	4 .....	96
White hot spiral .....	4.6.....	95.4
Electric light .....	10 .....	90

In medical work, the same agents are useful in cutting down the obscure radiations or thermal frequencies. A solution of alum in water is used for this purpose. Rock salt, which permits the passage of the ultra-violet frequencies, permits the passage of all the thermal frequencies and is therefore not so good as quartz in practical work, still by having a number of pieces and changing from a warm to a cool one, the end can be obtained.

In India it is the custom to paint goitres with red iodide of mercury and then expose the part to the action of sunlight. Doubtless this is done because of the fact that iodine absorbs all save radiation of great wave length. It is a great absorber of light. In the author's experience, a case of goitre was so treated by request of the patient, who had

---

<sup>1</sup>Landauer: Spectrum Analysis.

read largely but not always wisely. A few exposures resulted in a very severe dermatitis, infinitely more so than had followed the use of the same light source alone. Although told it would follow upon the treatment, the patient discontinued treatment upon its appearance and the ultimate outcome in relation to the goitre is not known

Calorescence.—As Stokes converted the rays of high refrangibility (see Fluorescence, Chapter XX.) into those of lower refrangibility and invisibility, so Tyndall increased the refrangibility of the infra or ultra-red frequencies, rendering them visible. This was done by placing the charcoal points of an electric-light filament in front of a concave silvered glass mirror, concentrating the rays to a focus about 6 inches distant. A cell full of a solution of iodine in carbon bisulphide, which has the power of stopping all luminous frequencies, but gives free passage to the non-luminous frequencies, was placed in the path of the beam, and a piece of platinum was then placed in the focus of the beam thus sifted and raised to incandescence by the invisible frequencies. In the same manner, charcoal in vacuo was heated to redness. Under a proper arrangement of the charcoal points a metal may be raised to whiteness, and the light emitted from it on prismatic analysis will yield a brilliant luminous spectrum. This luminous spectrum is derived entirely from the invisible infra-red spectrum, and to this transmutation of the non-luminous frequencies into the luminous frequencies Tyndall gave the name of *calorescence*.

Tyndall still further showed in these experiments that by placing the eye in the focus, guarded by a small hole pierced in a metal screen, in order that the converged rays should only enter the pupil, and not affect the surrounding part of the eye, no sensation of light was produced, nor was there scarcely any sensation of heat. A powerful beam undoubtedly reached the retina, although a considerable portion was absorbed by the humors of the eye, for under separate experiment Tyndall showed that about 18

per cent. of obscure radiation from the electric light passed through the humors of an ox's eye. The visual tract, i.e., the optic nerve and the brain, does not seem to be able to take cognizance of or respond to frequencies below the red either as light or heat.

Diathermancy and Athermancy—Transmission of Thermal Rays.—Diathermancy is the term used to express the power which bodies have of transmitting heat, and bears the same relation to radiant heat that transparency does to light. Athermancy, on the other hand, is the term used to express the power of stopping radiant heat and corresponds to opacity for light.

A diathermanous substance is one which allows incident radiation to pass through it, apart from any consideration of the wave length of the radiation. A transparent substance transmits waves of medium length, and may or may not be opaque to the very long or very short waves. A substance may be absolutely opaque and yet permit the ultra-violet or the infra-red or both to pass. By heat rays it is the infra-red which are generally understood.

By his experiments Melloni found that calling the total radiation 100 there was transmitted as follows:

Carbon bisulphide	transmitted.....	63
Olive oil	“ .....	30
Ether	“ .....	21
Sulphuric acid	“ .....	17
Alcohol	“ .....	15
Solution of alum or sugar	“ .....	12
Distilled water	“ .....	11

With solids when cut into plates 0.1 inch thick it was found that out of every 100 rays

Rock salt	transmitted.....	92
Smoky quartz	“ .....	67
Transparent lead carbonate	“ .....	52
Selenite	“ .....	20
Alum	“ .....	12
Copper sulphate	“ .....	0



A practical application of these tables is to be found in the small quantity of thermal frequencies transmitted through distilled water, hence the reason for using it preferably for the water-cooling cylinders of tubes with condensing lenses, as in the Finsen tube; and in the complete athermancy of copper sulphate the reason for its use as a filter when the solar energy is used for treating skin lesions.

Tyndall in a series of experiments made to show whether there was any relation between diathermancy and transparency proved that a layer of water 0.2 of an inch thick absorbs 80.7 per cent. of heat from a red hot spiral, and transmits 19.3 per cent., and that there was no such relation.

Influence of the Thickness and Nature of Screens.—Rock salt transmits all kinds of heat, i.e., from different sources, with equal facility, and is the only substance to do so. Its analogy may be found in white glass which is transparent to white light, no matter what its source. With most bodies absorption of heat increases with the thickness, although by no means in direct proportion. Rock salt is an exception to this rule. The absorption takes place in the first layers; the rays which have passed these possess the property of passing through other layers in a higher degree, so that beyond the first layers the heat transmitted approaches a certain constant value.

Bodies which transmit heat of any kind readily are not heated. For example, a window pane is not much heated by the strongest sun's heat; but a glass screen placed before a fire stops most of the heat and becomes heated itself thereby. So the blue glass screen used in connection with the marine searchlight mechanism: The patient exposed to the action of the blue frequencies suffers no heat, it is not transmitted, but the glass of the screen itself becomes very hot, sometimes cracking.

Absorption by Luminous Heat.—From his experiments Franklin found nearly a century ago that the absorption of heat by colored clothes increased with the darkness of the color. But he used a luminous source of heat, therefore,

his conclusions only hold good for luminous heat. With obscure heat, all clothes were equally absorbent.

The thermal frequencies or heat rays are susceptible of double polarization and refraction.

Dry air, oxygen, nitrogen and hydrogen are but little absorbent of radiant heat, their presence being but little different from a vacuum.

Assuming the absorption of dry air to be 1, carbonic acid, for example, under the same pressure, 30 inches, is 90.

The absorption of heat by gases varies with the pressure. Tyndall, in his experiments on the behavior of aqueous vapor to radiant heat, showed that on a day of average humidity the absorption due to the transparent aqueous vapor present in the atmosphere is 72 times as great as that of the air itself, though in quantity the latter is about 200 times greater than the former. He also showed that with the sun at heights which are virtually equal there is the smallest transmission of heat on those days on which the pressure of aqueous vapor is greatest; that is, when there is most moisture in the atmosphere. In this physical fact is to be found a reason for constructing incandescent light baths in such a manner as to prevent, if possible, great moisture of the air of the cabinet from the sudatory action established.

Perfumes are great absorbers of heat. Tyndall found that elementary gases were the feeblest absorbents, while gases of complex constitution were the most powerful. Thus it may be inferred that absorption is mainly dependent upon chemical constitution. Absorption and radiation are, therefore, molecular acts independent of the physical conditions of the body.

The properties which bodies possess of absorbing, emitting and reflecting heat meet with numerous applications in the domestic economies and arts.

Applications.—As a rule white bodies reflect heat very well, and absorb very little, but the contrary is true of black bodies. An exception is to be found in white

lead, which has as great absorbing power for non-luminous rays as lampblack. Dark cloth, cotton, wool and other organic substances when exposed to the action of radiation from luminous sources are powerful absorbents. White clothing is cooler for summer wear because it reflects by reason of the absence of color rather than absorbs the thermal frequencies of the solar rays. It permits the transmission of the chemical rays. Therefore in the tropics where the chemical intensity of sunlight is very great, red and yellow are worn underneath while white is used for outer wear. Polished surfaces emit heat more slowly than dull surfaces.

The upper regions of the atmosphere are cold, notwithstanding that they are traversed by intense heat because of the diathermancy of dry atmospheric air. The intense heat on the top of mountains is undoubtedly due to the comparative absence of aqueous vapor at these elevations.

The use of glass for shade in gardens to protect plants depends partly on the diathermancy of glass for heat from luminous rays, and its athermancy for obscure rays. The heat from the sun is largely of the former quality, but by contact with the earth it is changed into obscure heat, which cannot traverse the glass. A considerable part of the solar energy is transmitted by water, and bottles of water may act as lenses. Accidents might happen in this way, gunpowder, for example, be fired while a drop of water on leaves in greenhouses might act in the same manner, and to the destruction of the leaves. Rock salt coated with lampblack or still better with iodine transmits heat, that is, the infrared rays but completely stops luminous heat. Alum either as a plate or in solution, or a thin layer of water is permeable to light, but stops all the heat from obscure sources.

This property is made use of in apparatus illuminated by the sun's rays, in order to sift the rays of their heating power. If desired to avoid too intense heat from an electric light thus used a vessel of water or solution of alum is used.

For example, a Finsen tube on the one hand and a sun lens on the other.

The different sources of heat generally are (1) mechanical sources, comprising friction, percussion and pressure; (2) the physical sources, solar radiation, terrestrial heat, molecular action, change of conditions, and electricity; (3) the chemical sources or chemical combinations, and more especially combustion.

Radiant heat as it concerns us here originates from (1) the sun, and (2) from incandescent lamps. There is no source of heat so intense as that of the sun.

Attraction and Repulsion Arising from Radiation.—Crookes discovered a very remarkable class of phenomena which are due to the radiant action of heated and luminous bodies. It beautifully illustrates the attraction and repulsion arising from radiation (1) of radiant heat, (2) light visible and invisible, (3) cathode rays. A description of it is incorporated in this chapter.

Crookes' radiometer<sup>1</sup> is a device consisting of a lightly poised structure, similar to a windmill, weighing not more than two grains, secured in a glass bulb from which the air has been mostly exhausted, so as to leave a fairly perfect vacuum and which is fused at its proximal end into a glass tube, and this in turn is secured to a base of wood which serves as a support. The vane or fly, as it is called, is composed of tiny discs of mica fastened to four fine aluminum wires. These are secured in the centre of the vacuum tube or bulb to a fine steel point which is fused into the distal end of the bulb. The one side of the mica disc is covered with lampblack. When exposed to the action of light or heat, a candle, for example, brought near the fly, the fly is attracted and rotates slowly in a direction showing that the blackened side moves toward the light. This movement, which indicates an attraction, depends upon a certain state of rarefaction. The speed of the rotation of the fly gradually

---

<sup>1</sup>Ganot's Physics.

diminishes in rapidity as the air within the vacuum is still further rarefied until a certain point is reached when the fly ceases to rotate. Let the rarefaction be pushed beyond the point at which the rotation of attraction ceases and the reverse of the phenomenon takes place, viz., repulsion, and the blackened vanes move away from the source of light or heat. In a double radiometer, in which two flies are pivoted independently one over the other, having their blackened sides opposite each other, the flies will rotate in opposite directions on the approach of a lighted candle. The rotations are reversed when a cold body is brought near instead of a hot one. The experiments of Crookes and Kundt brought to light the very important fact that what had been regarded as a complete vacuum, was not in reality and the existence of a gaseous residue must be taken into account. The phenomena are not specially influenced by the nature of the gas, for whether the vacuum be one of hydrogen, or aqueous vapor, or of iodine vapor there is no material difference in the result, save that with hydrogen the exhaustion need not be pushed so far as with air. The repulsion takes place with all the rays of the spectrum, the intensity diminishing from the ultra or infra-red to the ultra-violet. The interposition of a plate of alum, when the chemical frequencies, violet and ultra-violet, are active, has no effect upon the phenomena, but a solution of iodine in carbon bisulphide diminishes the repulsion. The rapidity of rotation depends upon the intensity of the source of light. A strong light causes so rapid a rotation as to prevent determination of the rate of speed. Two candles, for example, placed at the same distance will secure double the speed of one. When two different sources of light are placed successively at the same distance, and produce the same rate of rotation, then their intensity is equal. If when placed at different distances they produce the same speed of rotation, their intensities are directly as the squares of these distances from the radiometer. This is the principle which governs the use of the instrument as a photometer, for comparing and measuring different sources

of light. Comparative measurements of the intensity of light may also be made by a Crookes radiometer, and the distribution of energy in the solar spectrum investigated by its means.

When the pressure has not been reduced beyond a certain point, i.e., as long as the apparatus still contains air, it is not difficult to explain the phenomena of attraction observed in the experiments by the action of convection currents.<sup>1</sup>

Heat falling upon the blackened disc will raise its temperature, and the temperature of a layer of air in immediate contact with the disc, would also be raised. This would cause it to expand and rise, flowing over the space behind the disc, thereby increasing the pressure there. The repulsion observed, however, at a higher degree of vacuum is due to a reaction behind the vane and the glass envelope, and is at once an illustration and a proof of the modern views as to the constitution of gases. The general nature of this theory is that gas is an assemblage of independent molecules, which are perfectly elastic, and which move with great rapidity; the pressure is caused by their impact against the side of the vessels in which the gas is contained. The equal transmission of pressure in gases is effected by the impact of the molecules against each other. The mechanical effect of the force of repulsion is calculated by Crookes to be equal to about the 1/100 of a milligramme on a square centimetre. This force is sufficient to account for the effects observed by reference to admitted principles of the mechanical theory of gases (Stoney). The light vibrations pass through the thin glass, without raising its temperature, and falling on the blackened side of the vane is absorbed by it. In consequence thereof it becomes slightly hotter. The layer of extremely rarefied air in its immediate contact with the blackened disc will also become somewhat hotter, and the molecules will fly from the disc with greater velocity. These more rapid motions would be equalized by their impacts

---

<sup>1</sup>For Convection Currents, see pp. 404, 414, Ganot Physics, 16th edition.

against other molecules and a uniformity of pressure, i.e., of temperature would be established under ordinary pressures or even at moderate degrees of rarefaction. With the increase of rarefaction, however, the frequency of these intermolecular shocks diminishes rapidly and in consequence a great number of the molecules, after having been heated by contact with the blackened sides of the palette, will strike against the cold glass. The effect of this will be to cool these molecules, that is, to diminish their velocity, and it will be this kind of molecules chiefly which will fall on the back of the disc and on the regions behind it. An excess of force equal and opposite to that on the glass acts against the front of the disc and accounts for the phenomenon exhibited by Crookes. Therefore, other things being equal a fly will rotate more rapidly in a small than a large bulb.

Spectrum Analysis.—Spectrum analysis is a chemico-analytical method by means of which it is possible to determine the constituents of a substance by observing the refraction (dispersion) or the diffraction of light rays.<sup>1</sup> It also offers an opportunity of investigating the molecular structure of matter. When light rays are refracted the image produced is termed a spectrum. Rays of all refrangibility are emitted by white hot bodies and form what is termed a *continuous spectrum*, Plate 1. On the other hand, glowing gases or vapors emit rays of definite refrangibility. The spectrum of these is a *discontinuous* one consisting of bright lines which are characteristic of each substance. These characteristic lines serve for the identification of given substances whether they exist singly or in connection with other bodies. In this way the constituents of the sun are known, as the solar spectrum with its many colors and shades of coloring is the written or pictured evidence of the nature of its molten matter.

In the passage of rays from a white hot solid through a colored medium, some of them are retained and give an

---

<sup>1</sup>Ganot's Physics, 16th edition.

*absorption* spectrum. This varies with the chemical composition of the medium. By reason of the extreme delicacy characteristic of spectra reactions, their employment has led to the discovery of a number of new elements which occur in small quantities only. The distance from the source of light has little effect on the spectrum, therefore, it is successfully employed for the investigation of celestial bodies, extending a knowledge of them not dreamed of and unattainable in any other way.

In common with all scientific development, the history of spectrum analysis is one of exceeding interest, and both for an epitomized historic sketch as well as complete spectrum analysis, the reader is referred to Landauer's work,<sup>1</sup> and also Watts' Index of Spectra.<sup>2</sup> Spectrum analysis was founded by Kirchhoff and Bunsen in 1859.

Spectra are obtained by means of (1) prisms and (2) by means of gratings. There are two kinds of gratings made, the one of glass, which is transparent, and the other of speculum metal. The latter is the one most commonly used in spectroscopic work as it absorbs less light than the glass. The most complete gratings are Rowland's. His plane and concave gratings with from 10,000, 14,438 and 20,000 lines per inch are almost faultless and comparatively free from scratches caused by irregularity of the diamond point.

Diffraction.—The production of spectra by means of gratings is due to diffraction; part of the light traversing the spaces between the rulings continues in a straight line, but a portion is bent sideways or refracted by the edges of the opaque parts.

The wave theory of light permits of the following explanation of this phenomenon: The light waves which fall on a fine slit cause the particles of ether present to vibrate; this motion is communicated to the neighboring particles and produces an equal number of light waves, which reinforce, weaken or neutralize each other, in accordance with the law

---

<sup>1</sup>Spectrum Analysis, John Landauer.

<sup>2</sup>Watts' Index of Spectra.



of interference. This neutralization occurs in all directions, in which the difference between the two sets of waves is other than a whole wave length. The image of the slit in the middle in white light diffracted by a grating is white, because at this point all the colors are superposed, but the color waves which differ by one wave length collect at each side according to their wave lengths, and form a spectrum of the first order; these rays with a greater difference of phase forming the spectra of the second, third . . . mth order.

When the distance between the lines of the grating is known the wave lengths are determined by measuring the angle of diffraction with a gonimetre.

In this way the following values in ten millionths of a millimetre for the Fraunhofer lines of the spectrum were obtained. (See colored plate.)

The wave lengths are given in Ångstroms :

A	7954.06	
B	6876.46	
C	6563.06	
D <sub>1</sub>	5896.15	
D <sub>2</sub>	5890.18	Sodium Lines.
E <sub>1</sub>	5270.50	
E <sub>2</sub>	5269.72	
F	4861.49	
G	4308.	
H <sub>1</sub>	4101.85	
H <sub>2</sub>	3968.62	

The wave length  $\lambda$  (1) is determined by dividing the velocity ( $v$ ) (2) by the frequency. The wave length of the extremity of the visible red found at the lower end of the spectrum, is for the A-line .000076, that of the yellow D-line .0000589, and that of the K-line at the limit of the visible violet, .000039 mm. The velocity of light is known to be about 300,000 kilometres per second.

Given the velocity and the frequency, the number of the vibrations ( $n$ ) can be obtained by the formula  $n = \frac{v}{\lambda}$ ,

These are two common units of wave lengths smaller than the millimetre. By reason of the magnitude of the figures when the millimetre is used, it is much more simple to use the unit adopted for the measurement of wave length in a vacuum, the millionth part of a millimetre—0.001 micron. This unit is represented by the symbol  $\mu\mu$ . One-tenth part of this, equivalent to  $1/1000000$  of a millimetre, is known as Ångstrom's unit. As visible radiation is from .000077 to .000039 millimetre, its equivalent in microns is from 0.77 to 0.39 micron or 7,700 to 3,900 Å. or Ångstroms<sup>1</sup>

These numbers are inconceivably great, therefore it is usual to define the color by the wave length, although this varies with the medium.

Listing's scale is used for the classification of lines of the spectrum, according to color; it runs as follows:

....	to 7230	infra-red.	5850 to 5750	yellow.	
			4540 to 4240	indigo.	
7230	"	6470	red	5750 to 4920	green.
			4240 to 3970	violet	
6470	"	5850	orange.	5920 to 4550	blue.
			3970 to ....	ultra-violet.	

The most readily recognized lines in the spectrum are from A to H. The eye is most sensitive to the light between D and E, that is, a part of the yellow. The light becomes less and less visible from that point toward either end, until the red rays beyond A and the ultra-violet beyond H are hardly distinguishable

The solar spectrum is crossed by thousands of black lines known as Fraunhofer's lines, from the name of the discoverer, scattered here and there in the midst of the brilliant and gorgeous colors of the spectrum. Every phase of matter known casts lines in the spectrum which are bright and highly colored, not black. Or in other words each phase of matter, when corpuscles are torn apart and separated widely enough to allow them to oscillate, vibrates at

<sup>1</sup>Landauer: Spectrum Analysis, pp. 11, 12.

its own definite rate. The oscillation of each corpuscle will cause another to swing, and another, the motion being in a wave movement. But each wave strikes its own place in the spectrum and the bright lines in the spectrum are formed by sets of the similar waves, due entirely to their wave length and rates of oscillation. These appear in the solar spectrum as a result of the intense heat acting upon the different substances of which the sun is composed. Artificially, there is to be had in the electric arc a similar source of energy, and by placing in the crater of the positive carbon different substances for volatilization, or forming the electrodes of them as with carbon, they are torn apart by the intense heat and their corpuscles are made to swing at their own rate. The instant the gas becomes hotter than white is the instant when each corpuscle is torn away from all the others, to vibrate at its own rate. And as the corpuscles swing or oscillate one after another to form a wave they take a definite place in the spectrum, easily determined by means of a spectroscope.

They may each one be regarded as a letter in nature's alphabet. Their positions are measured with accuracy, and waves sent from iron, oxygen, sodium, titanium, helium, potassium, no matter what the substance, fall absolutely into their own and a definite place in the spectrum.

The Visible Spectrum.—Only the small portion of the spectrum between wave lengths  $400\mu\mu$ , and  $760\mu\mu$  is, in ordinary circumstances, visible to the eye, but the part beyond  $800\mu\mu$  becomes visible if the shorter waves are cut off, by means of a dark red glass, whilst those far beyond the  $400\mu\mu$  are seen if the longer waves are eliminated.

The Invisible Spectrum.—The region beyond  $760\mu\mu$  is termed the infra-red, while that below  $400\mu\mu$  forms the ultra-violet. In the former Langley reached a wave length of  $5300\mu\mu$  and Rubens one of  $575\mu\mu$ .

The infra-red rays may be detected by their thermal and photo-chemical properties and also by means of phosphorescence. See page 76. For the investigation of this region

Langley's actinic balance or bolometer is employed; by its means a rise in temperature of  $0.000001^{\circ}\text{C}$ . may be detected.

Langley's Bolometer.—This consists of a Wheatstone bridge, the arms being formed of two extremely thin blackened wires of equal resistance; if the temperature of one changes, the equilibrium is disturbed and the galvanometer affected.

Chemical Action of the Red and Infra-Red Rays.—For a long time it was supposed that this part of the spectrum was incapable of chemical action. Becquerel, however, observed that the red rays affect silver chloride, which has been previously exposed to light for a short time. Draper succeeded in photographing the beginning of the infra-red spectrum, but it was not until Abney prepared a special bromo-silver emulsion—sensitive to the infra-red—that complete photographs were produced. He has obtained photographs of the solar spectrum up to wave lengths of  $2700\ \mu$ , both with a prism and a grating, and also photographed a number of absorption spectra.<sup>1</sup> The most complete photograph of this region is due to Langley, however.

The ultra-violet region in the solar spectrum does not extend beyond about 300 microns. With an increase of temperature the spectra tend to develop into the violet. Hence, on account of the extremely high temperature of the sun, a considerable portion of its spectrum must necessarily escape observation. In this connection the reader is referred to Chapter XVI. Suffice to say here that according to Langley<sup>2</sup> it would take nearly 100 feet of map to depict on a prismatic scale the spectrum of the ultra-violet region, though it is caused by but a small fraction of the sun's energy, so monstrous is the exaggeration due to dispersion of the prism. It really contains much less than the one-hundredth part of the total solar energy which exists the visible spectrum containing perhaps one-fifth the energy of

---

<sup>1</sup>Landauer: Spectrum Analysis.

<sup>2</sup>Langley: Smithsonian Reports, p. 684.

the sun." The length of the spectrum beyond the violet is still unknown, the researches of Schumann giving the shortest wave length yet recorded photographically, the only means available for the chemical end of the spectrum other than their fluorescing properties, and its wave length is 1200 units. The lengths of the waves produced by the oscillating corpuscles of this region are extremely short, and it is supposed that they continue to become shorter until they become electro-magnetic Roentgen waves.<sup>1</sup>

Iron vibrates at many different rates and its spectrum is the richest in lines; they are distributed over every part of the field. It beats with 480 different velocities

Kayser and Runge<sup>2</sup> measured more than 4500 lines, and on comparing them with Rowland's solar atlas between  $520\mu\mu$  and  $320\mu\mu$ , they were unable with certainty to detect a single line which does not appear in the solar spectrum. Cornu photographed the more prominent lines in the ultra-violet, i.e., between  $410\mu\mu$  and  $295\mu\mu$ . This region was extended by Liewing and Dewar between  $295\mu\mu$  and  $230\mu\mu$ . It is because of the arc spectra of iron that it is valuable therapeutically.

If the length of the light spectrum be placed at one, that of the heat spectrum is 13, while that of the chemical is unknown.

Fraunhofer or Black Lines of the Spectrum.—Fraunhofer in 1824 observed the coincidence of these sodium lines with the double D-lines of the solar spectrum. In his study of absorption spectra Kirchhoff proved the nature and origin of these delicate dark parallel lines which web themselves across the solar spectrum. Fraunhofer discovered them by the use of a telescope. Kirchhoff explained the reason for their existence. If two waves, formed by the oscillations of their light corpuscles, exactly alike, interfere, both are totally destroyed.

Illustration of the Interference of Waves.—Let two

---

<sup>1</sup>Larkin: Radiant Energy.

<sup>2</sup>Quoted by Landauer.

stones be dropped in water at some distances apart. The waves to which they give rise will expand in circles; in a short time the two circles will collide; but if two waves in opposite phase meet, the water will be at rest and a cork floating thereon will not oscillate. It is a principle of wave motion that waves interfere. If two water waves interfere, rest succeeds; if two light waves darkness. Therefore, concludes Larkin, whose simile is used, stillness in water corresponds to darkness in the midst of light, for light added to light may produce darkness.

Take sodium, for example. When sodium is heated hot enough to be torn apart, either in a Bunsen burner or by the electric arc or spark, two bright yellow lines will flash out, and all the other portions of the spectrum will be black. This is because the metal sodium can only vibrate at two rates, that is, it can only be torn into corpuscles at these two rates, and, therefore, the whole of the spectrum other than these two yellow lines is black. The metal sodium, the basis of common salt, is omnipresent, for the ocean spray as it evaporates in the air leaves minute particles of salt in suspension. As little as 14 millionths of a milligram of sodium is sufficient to project the well-known sodium lines. The rustling of a paper, or movement of a hand through the air is sufficient to arouse a hurricane of these particles. In the act of examining the spectra of any given substance they fall into the source of heat, are instantly torn into corpuscles hundreds of millions of times smaller; and these set up their own waves which enter the slit.

If a strong white light concentrated into a beam be sent from an electric arc, through the flame in which the sodium has been torn apart the bright yellow lines will vanish, and all the other parts of the spectrum appear, save in the two places occupied by the bright sodium lines, which now, however, are black.

If, instead of the arc light, sunlight be sent through the yellow flame the two black lines in the yellow region of the solar spectrum become blacker than before. The corpuscles

of sodium can only oscillate at the two rates and at no other. Therefore the yellow flame lets every other color rate due to oscillating light energy through without hindrance, and absorbs the yellow producing the black lines. This discovery of the fact that the black lines were due to absorption led to the formation of the following law by Kirchhoff:

All modes of matter when vibrating at their own rates absorb the same waves they are able to generate.

Since the solar spectrum has dark lines where sodium, iron, etc., give bright ones (see frontispiece), it is assumed that around the solid, or more probably the liquid body of the sun which throws out the light, there exists a vaporous envelope which, like the sodium flame of the illustrative experiment, absorbs certain rays, namely, those which the envelope itself emits. Therefore those parts of the spectrum which, but for this absorption, would have been illuminated by those particular rays, appear feebly luminous in comparison with the other parts, since they are illuminated only by the light emitted by the envelope and not by the solar nucleus; at the same time the conclusion is forced that in this vapor there exist the metals sodium, iron, etc. Each condition of matter when its corpuscles are vibrating at their own characteristic rate causes different sets of waves, varying in length, amplitudes and periods of oscillations. All the 80 or more modes of matter which the analytical spectroscopist has caused to vibrate in front of the slit of the spectroscope by heat, as in the electric arc between carbon terminals into whose positive crater metals were placed, cast in their respective spectra the same lines as those found in the solar spectrum, demonstrating their presence in the gaseous envelope.

### Absorption Spectra.

The absorption spectrum of a substance corresponds with its emission spectrum at the same temperature and in the same molecular condition.

This law, the law of exchanges, was established by Kirchoff in 1859, as a result of his study of absorption-spectra, viz., the relationship between emissive and absorptive power of all substances for light of the same wave length.

The fact that reflected light is of less candle-power than the impinging light leads up to one of the most interesting and important phenomenon in light physics, and one that is especially valuable in its physiological relation, viz., that of absorption.

Absorption of light energy does not mean its loss; on the contrary, whenever and wherever the phenomenon of absorption is observed, there is work done. Throughout the subsequent chapters of this volume, it is referred to again and again as of great importance. No energy is lost. This is according to the law of conservation of energy. The extinction of energy in space or its absorption and consequent disappearance in matter is one of nature's fundamental truths. When absorbed, it is converted into other forms of energy of equal value. When the waves of light fall upon a growing plant, for example, they do work. They are said to be absorbed, and the green leaf absorbs all the frequencies of light energy save the green which are reflected. In the light-absorbing substance a transformation takes place, beautifully shown in the green leaf by the chlorophyll function. In the appropriation and selection of waves by matter, whatever its nature, the light is sensibly weakened, as in passing through the substance a part of its energy has been absorbed.

Every black line in the solar spectrum is an absorption letter, by means of which the waves that are absent may be read.

Absorption spectra are usually observed at low temperatures.

Fluorescence and Absorption.—The phenomena of phosphorescence and fluorescence are associated with absorption of light.



Certain substances become luminous by the action of light; if the luminosity ceases upon the withdrawal of light they are said to be fluorescent (see Fluorescence, Chapter XVI.), whilst the term phosphorescent is applied to substances which continue to be luminous after the light is cut off. In accordance with the law of conservation of energy, the rays causing these phenomena are absorbed, fluorescent bodies exhibit corresponding absorption spectra, and as they absorb the ultra-violet more or less completely, they all fluoresce in this region of the spectrum.

Phosphorescence.—Under the name of phosphorogenic rays Becquerel has described the rays given by phosphorescent substances.

These are rays which have the property of rendering certain objects luminous in the dark after they have been exposed for some time to the light. This is a species of luminosity very closely allied to fluorescence. Indeed, according to Becquerel, who discovered this property in luminous rays, fluorescence is only phosphorescence of very short duration. He distinguishes between the rays which originated the luminosity, the exciting rays, and the continuing rays to which he gave the name of phosphorogenic rays.

In fluorescent bodies the radiation exists only during the time the body is exposed to the exciting rays of light. In phosphorescent bodies, however, the radiation persists after the exciting cause is withdrawn. Among some of the natural and artificial substances which have the quality of phosphorescence may be mentioned diamonds, calcareous spar and sulphide of calcium. The latter is the best and most brightly phosphorescent substance known up to now. It is called after its discoverer, "Balmain's Luminous Color."

Artificial phosphorescent bodies include the sulphides of the alkali earths, which are obtained by heating sulphur with limestone, barytes or strontium salts.

Color of Phosphorescent Light.—The colors of phosphorescent light depend not only upon the chemical constitu-

tion of the substances which emit them, but also upon the physical nature and temperature.

Intensity of Phosphorescent Light.—The intensity of phosphorescent light is increased by heating. The waves of phosphorescent light, as those of fluorescent light, are of greater length than the exciting light. There is considerable evidence to indicate that in phosphorescent light energy is given off, which has been taken from the absorbed light of the exciting light source. This is in accord with physical laws, for absorption means work done or energy imparted. Phosphorescent light always has a far weaker light than the light acting to produce the phosphorescence. It has been calculated that the light of the best and most brightly shining phosphorescent substances excited by daylight, when in immediate contact with bromide-of-silver gelatin plate, acts about as powerfully as the light of one normal candle at 50 centimetres distant.

Phosphorescent Light Renders Visible the Infra-Red Spectrum.—Becquerel and Seebeck discovered that yellow and red rays counteract the action of the violet rays, in other words, extinguishing or at any rate considerably weakening the brightness produced by them.

As fluorescent plates or the substances are used to render visible the ultra-violet spectrum (see Chapter XVI.), so phosphorescent plates were used by Becquerel to make the infra-red visible. For example, if a plate covered with Balmain's luminous color, which has been exposed to daylight, and is, therefore, luminous, is then exposed to the infra-red spectrum, i.e., the dark, at first the spectrum bands become brighter, the Fraunhofer lines remaining unaltered. This soon changes and the Fraunhofer lines gain in luminosity until they appear bright on a dark ground.

Duration of Phosphorescent Light.—This varies with different bodies. There is no connection between the intensity of the phosphorescent light and the duration of the luminosity.

Absorbed Light, the Action of.—From a study of the

physical effects of light we find that absorption is a most important phenomenon of light energy. The appropriation and selection of waves by matter and their eventual return to space constitutes the life of the universe. None of this absorbed light is lost.

Heating Effects and Calorescence.—(1) It is transformed into heat; the rays which fall upon a body heat it and are emitted as obscure heat rays of greater wave length, the reverse of which is true. The body upon which obscure heat rays fall may be heated till it shines. To this phenomenon Tyndall gave the name of Calorescence.

Fluorescence.—(2) In certain substances absorbed light causes the immediate emission of new light rays of different colors. This is known as Fluorescence. (See Chapter XX.) The luminosity of these bodies exists only through the period of their lumination. The color of the light emitted is different, both from the impinging light and from that of the body itself. Reflected rays cause the colors of bodies, but the coloring of fluorescent bodies is due to the absorbed rays.

Phosphorescence.—(3) A more or less continuous emission of new light rays of different colors is produced by absorbed light. To this is given the name of phosphorescence, of which a notable example is sulphide of calcium.

Chemical Effects.—(4) Chemical effects may be produced; notably decomposition. The most intense chemical energy of the spectrum is found at the extreme or ultra-violet end. All frequencies from blue up to ultra-violet are also chemical in their action but less than those of the ultra-violet. Light exerts a chemical action in numerous phenomena. For example, silver chloride blackens under its influence; transparent phosphorus becomes opaque; vegetable coloring matters fade; hydrogen and chlorine gases when mixed combine slightly in diffused light and with explosive violence when exposed to direct sunlight.

Scheele found that when silver chloride was placed in violet the action was more energetic than in any other part; but it was further observed by Wollaston that the action ex-

tended beyond the violet. This chemical action of ultra-violet energy is fully considered in the chapter devoted to that subject.

Photography is based on such effects.

Mechanical Effects.—(5) Light energy under certain conditions produces mechanical results (illustrated by Crookes' Radiometer).

Electric Phenomena.—(6) By the vibrational activity of the oscillating light corpuscles, in many instances, electric phenomena are caused.

The Relation of Colors of Bodies to the Colors of the Spectrum.—The color of a body is not identical with the color of the spectrum, but is dependent on the light striking it. Certain component parts of the light are absorbed by the body which reflects or permits the passage of the others. In the one instance it is opaquely colored and in the other transparently colored. There is, then, no color in bodies, the color is in the light. The transparent body is transparently colorless if it permits the equal passage of all parts of the impinging light. For example, it is transparently blue if it absorbs all but the blue light. Blue solution of copper sulphate absorbs the red and the yellow chiefly and permits the passage of the green and violet; but not so freely as blue, hence it takes on a blue color.

Yellow color solutions permit of the passage of the yellow rays, less freely the red and the green, absorbing the blue and the violet entirely.

The whiteness of an opaque body depends upon its ability to reflect equally and strongly all the component parts of white light; if black it absorbs them. Of practical interest in this connection is the fact that colorless bodies which are equally transparent to light may vary very greatly in the degree to which they permit the passage of the chemically active rays. For example, rock salt and quartz absorb them least of all: "Double-spath-soda" absorbs these rays less than crown glass and flint glass.

The red frequencies penetrate bodies much more readily

than do the blue. A spectrum analysis of lamplight which has been passed through a thick sheet of paper will show that all blue light has been absorbed and that only the red and yellow remain.

If the absorbing layer be thicker, the red only will pass through. The same holds good of gases and vapors, as the atmosphere, for example. The matter of atmospheric absorption is a matter of constant reference in the pages which follow.

Absorption takes place the more readily, the sharper the light at which the angle is reflected.

Properties of the Spectrum.—The spectrum is regarded as possessing luminous thermal and chemical properties. As pointed out in relation to many different aspects of the subject, these properties are not inherent through any single frequency or a group of frequencies, but they exist in all of the different frequencies of the spectrum according to the substance upon which the light falls.

The thermal effects are considered in the Physics of Radiant Heat as well as in the therapeutics of the subject of light energy, while the chemical effects especially considered in Chapter XVI. form an inherent part of every aspect of the subject of light energy in its physiologic and therapeutic relations.

Spectroscope.—The spectroscope is not only useful for the purpose of analysis of solar light but it also sustains a relation to the use of light in therapeutics: (1) In experimental work where it is desirable to exclude all but certain frequencies of light vibration; (2) to carefully analyze the light allowed to penetrate into rooms in which patients suffering from smallpox or the exanthemata are placed; (3) to analyze the spectra of the different sources of light used by the physician; (4) for the purpose of investigating substances which have a special importance in physiology and pathology, normal and diseased blood, for example. The first is illustrated by experiments of Bernard and Morgan upon bacteria, the second by the preparation of the Finsen red room.

The Spectrum of each Light Source Varies.—The light-giving power in the several parts of the spectrum from various sources of light is well illustrated by the following classic table:

	C Red.	D Yellow.	C'	F $\frac{1}{2}$ G. Blue.	Total light power expressed in normal candles.
White light.....	73	100	104	134	1
Gaslight.....	74	100	103	125	16
Lime light.....	59	100	113	285	90
Electric Arc light.	61	100	121	735	362
Magnesium light..	50	100	223	1,129	215
Moonlight.....	87	100	155	363	204
Sunlight.....	45	100	250	2,971	70,000

An analytical glance at this table will show the very great preponderance in sunlight from the F $\frac{1}{2}$  to the G line in the energy of the blue, which all of the evidence thus far elicited has shown to be so valuable, physiologically and therapeutically. A glance at the continuous solar spectrum will still further emphasize this fact.

Magnesium Light.—The light next rich in the very valuable rates of oscillating light energy is the chemically active magnesium light, which, as compared with the sun, is as 1,129 to 2,971. This is the most intensely active chemically of all sources of artificial light, but it burns away with very great rapidity so that it is impossible to keep a continuous powerful illumination, as is necessary in all therapeutic work. Additionally it gives off a great deal of smoke, which precludes the possibility of using it for therapeutic purposes, rich as it is in the blue frequencies and powerful as it is photographically.

It will be seen from the pages which follow upon the electric arc that it amply fulfils the conditions for an artificial source of light energy.

Influence of Atmospheric Conditions.—Ultra-violet absorption, according to Cornu,<sup>1</sup> is essentially due to the nitro-

<sup>1</sup>Landauer: Spectrum Analysis.

gen and oxygen of the air, although it is generally attributed to the presence of the varying constituents of the air, water vapor, carbonic acid and dust, factors which may possess a contributory effect. All wave lengths of less than  $307\mu\mu$  are thus absorbed. This absorption is also influenced by the movement and the temperature of the air.

According to Rowland's tables of wave lengths, the water vapor and oxygen of the atmosphere are the only substances which produce absorption in the visible region, while nitrogen, carbonic dioxide and ozone appear to exert no influence.<sup>1</sup>

Thus, it will be seen, that the absorption varies greatly for the different frequencies. The violet which are the chemically active frequencies suffer more than the green and yellow, which are the most effective in the growth of plants; and these again more than the red; and the red, in their turn, much more than the low pitched slowly vibrating waves below the red which, though invisible, are still powerful carriers of energy. Generally speaking, according to Young<sup>2</sup> it may be estimated that at the sea level, in fair weather, neither excessively moist nor dry, about 30 per cent. of the solar radiant energy is absorbed when the sun is at the zenith, and at least 75 per cent. at the horizon. Of the rays striking the upper surface of the atmosphere, between 40 and 50 per cent. therefore are generally intercepted in the air even when there are no clouds.

According to Langley the following percentage of the frequencies of the different regions of the spectrum pass the atmosphere:

Ultra-violet .....	39 per cent.
Violet .....	42 " "
Blue .....	48 " "
Greenish blue .....	54 " "
Yellow .....	63 " "
Red .....	70 " "
Magnesium light: Infra-red.....	76 " "

<sup>1</sup>Landauer: Spectrum Analysis.

<sup>2</sup>The Sun, Young.

## The Electric Arc.

Over a hundred years ago, March 20, 1800, Volta wrote his first letter announcing the discovery of his pile.

Upon this discovery the scientific world was as much agape as in these latter days it has been over the discovery of the X ray by Roentgen, of Becquerel rays by Becquerel, and more recently still the discovery of radium, with all its wonderful significance to pure science by Professor and Madame Curie. The experimental investigation of the early days of the voltaic pile may be classified as follows: (1) "Those which dealt with the effect of the current on living things. (2) Those which produced chemical decomposition of inorganic matter, particularly of water. (3) Those which dealt with the heating power of the current, more particularly with the sparks produced by making or breaking a circuit."<sup>1</sup>

It was this last series of experiments which led to the discovery of the arc.

At the time of Volta's discovery and subsequently, one of the earliest experiments was to make a spark by bringing the two terminals of a battery together, in order to show that the current from the pile of Volta was of the same nature as "common electricity," so well known to the physician of to-day as static electricity.

This was accomplished by many observers, but Sir Humphry Davy, October, 1800, was the first to try the effect of two well-burned pieces of charcoal as the conductors. Charcoal had already been shown to be a good conductor of electricity by Priestley.

Davy reported that he found that this substance possessed the same properties as metallic bodies in producing the shock and spark which made a medium of communication between the ends of Volta's pile.

In a lecture before the Royal Institution in 1801, Davy stated that the spark passing between two well-burned pieces

---

<sup>1</sup>The Electric Arc, Aryton, p. 20.



of charcoal was larger than that passing between brass knobs "and of a vivid whiteness;" an evident combustion was produced, the charcoal remained red hot for some time after the contact, and threw off bright corruscations.

Thus was conceived the idea of the electric arc. But there was no continuity to the phenomena observed by Davy. It was only the discontinuous spark. The very nature of an arc requires continuity, and that the two poles should not be in contact after ignition. Later, in 1802, Davy reported to the Royal Institution that he had tried the effect of the electrical ignition of dry charcoal upon muriatic acid gas confined over mercury, with the result of making the charcoal white hot by successive contacts for nearly two hours. Had there been the proper relation between the E. M. F. and R. of both the internal and external circuits, the continuity of the spark obtained would have been established and the electric arc then and there would have become an accomplished fact.

The batteries of that earlier time were so constructed as to have a very great internal resistance, i.e., small plates. Fourcroy, Vacquelin and Thenard, in 1801, discovered that this resistance could be lowered by the use of larger plates, and it was soon found that fewer and larger pairs of plates gave better results in the production of sparks and heating effects than a greater number of pairs with small plates.

Numerous experiments were made in 1801, on the continent, with the spark thus obtained from the contact of the two terminals of the voltaic pile, in France by Fourcroy, Thenard and Vacquelin, and in Germany and Austria by Ritter, Thormsdoff, Gilbert and Pfaff.

Gold and silver leaf, as well as thin wires, were burned, causing flames to arise between the two poles. In some instances a single spark was obtained, in others a continuous and rapid succession of sparks, but the experimenters failed to differentiate between them, therefore "the actual discovery of the electric arc, both as to discoverer and time, is shrouded in mystery."

Frictional electricity, with which scientists had worked up to that time, presents the phenomena of a succession of sparks always, when the mechanism is in operation, and, therefore, the first observer of a succession of sparks from a voltaic pile was in all probability unimpressed by the phenomena.

An electric arc is after all but a spark, but it is a continuous spark, maintained after first contact of the two terminals or electrodes, even though there be a space between the electrodes, and to insure such continuity there must be the necessary and definite relation between the electro-motive force and the resistance as well as the proper feeding arrangement of the mechanism.

Sir Humphry Davy was the first to describe this long horizontal arch of flame by reason of which the arc is named, although, as stated, it will never be known to whom the actual discovery should be accredited. To him, however, is due alike the conception and description, and in 1820, after he had shown that the flame was deflected by a magnet, first predicted by Arago, though unknown to Davy, the latter gave to the phenomenon the name of the *arc*.

It is not generally realized by physicians using static machines that to the discharge of the spark gap from a frictional machine, the first conception of the arc is due, although not until Volta's discovery was it possible to establish the necessary conditions. To recognize the kinship of all these various manifestations of energy, luminous and electrical, is to unify one's knowledge of these agents to the end of their more intelligent use in therapeutics.

The development of the electric arc to its present practical position has been the result of many years of study, investigation and experimentation, the history of which, all down through the nineteenth century, is one of great interest, and the student will find an extensive bibliography upon the subject replete with interest and useful knowledge.

The difference of potential, in spark discharges and also in the discharge from a point, between the electrodes is very

great, several hundred volts, but the current is only a fraction of a milliampère. This is not only true of the spark discharges but also of the convective discharge from a static machine with which one is so familiar. With the electric arc, however, when the electrodes are in a state of incandescence, the potential difference is very much smaller, while the current is enormously greater, often amounting to many ampères.

When two carbons or conductors of other metals are brought together and slowly separated, the electric current does not immediately cease to flow; in other words, if the carbons or rods are not too widely separated, the circuit is not broken, but the space between them is traversed by a cloud of highly heated metallic vapor which carries the current. And although the current passes, there is no spark produced in the air, as for example, with the static machine or a high-tension coil, because there is not sufficient difference of potential to produce a spark in air. The electric current is assumed to flow from the positive pole of the source of E. M. F., through the circuit to the negative pole. In an electric arc, the direction of the current is the same from the positive carbon rod or electrode, across the gap formed by the interruption of the current, to the negative rod or electrode that it may reach the negative pole of the source. But when the carbons are separated about one-tenth of an inch, 3 mm., an arc of violet-colored light is formed between them, and the ends of both become brightly incandescent, the positive more than the negative. This incandescent cloud of vapor formed between them assumes a bow or arc-shaped form. This bow shape exists even when the carbons are vertical owing to the magnetic action of the earth's lines of force on the current. This arc may be a carbon arc, an iron, silver, cadmium or a copper arc, taking its name according to the metals employed. The color of the arc and the character of the spectrum produced by it depends upon the nature of the contacts or electrodes employed.

If copper is used, the light takes on the greenish coloring characteristic of copper. With iron there is an intense dead bluish white light with a great deal of violet coloring. With carbon contacts the light produced is of a vivid dazzling whiteness. This has the quality of sunlight. The light from a carbon arc more nearly approaches the quality of sunlight than the light of the metallic arcs referred to, and should, therefore, preferably be selected, when it is desired to utilize the activities of the electric arc for the purposes of a general therapeutic administration, for example, in an exposure of the entire nude body to all its radiant energy. Not only should it be a carbon arc but a solid uncored carbon, because the softer core sometimes used to secure the greatest liberation at the center volatilizes at a lower temperature, the arc is confined to a limited area, and, therefore, there is less of the blue frequencies than with the solid core. This does not refer to an iron core. Different substances volatilize at different rates, and the place in the spectrum of any given metal depends upon the rate of vibration or volatilization of that metal. For example, in a wick which has been saturated with a solution of common salt, then dried and exposed to the action of heat, the heat volatilizes the metal sodium, tearing its particles away from their union with chlorine. The sodium particles vibrate at their own rate, and the flame is filled with dense yellow light. If this light be passed through the slit of a spectroscope, two brilliant yellow lines will be seen in the spectral field, in exactly the same position as Fraunhofer's black lines, but the remainder of it will be dark. This is because sodium is only able to vibrate in two rates.

The blaze from a driftwood fire at the seashore gives a spectrum rich in yellow, because of the impregnation of the wood by the salt of the ocean. Sodium of all metals possesses the greatest spectral sensibility, and it has been ascertained that  $1/200000000$  of a grain of sodium is enough to cause the appearance of the yellow line. The rates at which different metals vibrate, dependent upon the

temperature at which they volatilize, can readily be seen from Plate 1. Bodies at a red heat give only a short spectrum, extending at most to the orange; as the temperature gradually rises, yellow, green, blue and violet successively appear, while the intensity of the colors near the lower end of the spectrum increases. In Plate 1, colored, the spectra of certain substances examined with the spectroscope are shown.

If the physician will examine for himself the spectra of his light apparatus he will have a very vivid picture before him of the rates given off by the source of light he is using, and as to its richness in the chemical frequencies, so precious in therapeutics.

Returning, however, to the electric arc, a strong current flows when the carbon rods are brought into contact and just before separation the resistance is very great. By reason of this great resistance the carbon is raised to a very high temperature and a portion of it is converted into carbon vapor, which is a sufficiently good conductor to allow a steady current to flow through it.

The temperature necessary for the volatilization of the carbon is not reached at the extremities of both rods, but only at the positive. The temperature of the negative, except at its extreme point is always considerably lower than that of the positive. The difference is due to the fact that the larger part of the energy is transformed into heat at or near the surface of the positive carbon. The average length of an electric arc is 3 mm., but the distance between the carbons which govern the length of the arc, varies with the kind of carbon and with the active electro-motive force.

The crater formed at the end of the positive carbon is due to the combustion of the carbon, and the shape of this crater depends upon the length of the arc. In appearance the crater of the positive carbon suggests the crater of a volcano. The end of the negative carbon is conical shaped. This is due chiefly to combustion, but is contributed to by

the deposition of particles of condensed carbon vapor from the positive pole, which help to build it up. Both terminals lose weight, but the positive more rapidly than the negative. This description applies to the carbons of a direct-current arc.

These particles of boiling carbon can be seen floating off from the positive carbon by projecting the image of the arc on a screen or blank wall. Part of them float off into the surrounding media and part in a condensed form, as has been stated, are conveyed to the end of the negative carbon. This is a characteristic action of the current, and partakes of the nature of cataphoresis or the actual transfer of substances, from the anode to the cathode.

The crater of an electric arc has a very high temperature, that of boiling carbon,  $3,500^{\circ}\text{C}$ . or  $6,332^{\circ}\text{F}$ . as proved by Violle, the interior of which is the brightest part of all. The intense heat thus generated can be realized when the melting point of platinum is considered, which is  $1,775^{\circ}\text{C}$ . or  $3,219^{\circ}\text{F}$ . The size of the crater varies with the size of the carbons and the amount of current consumed. The temperature of the negative carbon is between  $2,100^{\circ}\text{C}$ . or  $3,772^{\circ}\text{F}$ . and  $2,500^{\circ}\text{C}$ . or  $4,532^{\circ}\text{F}$ . This tremendous temperature of the electric arc renders it very efficient in electric welding and in operating electric furnaces. Both temperature and luminosity are chiefly due to the conversion of electric energy into heat, but are partly derived from combustion of the carbon in air.

The dazzling brightness of a carbon arc, a miniature sun in fact, is such that it can only be observed through smoked or densely colored glass. Upon examination in this way, the observer notes that the arc or bow-shaped bluish flame which appears in the gap between the two opposed carbons is very much less brilliant than the ends of the carbons themselves. The characteristic change in the shape of the arc will be noticed after it has been maintained for a short time, i.e., the end of the positive electrode is hollowed out in the form of a small crater, while the negative





Fig. 1.—Carbons used in clinical work with a 25-ampère arc. The upper or positive carbon shows the crater-like depression, the lower or negative carbon the nipple-like projection. The area of incandescence is clearly shown as well as the disintegrating action upon the carbons under the double influence of volatilization and oxidation.



or opposed carbon has a minute nipple-like projection formed on the end just opposite the crater in the positive carbon. The positive carbon is brighter than the negative, but most of the light, however, issues from the crater itself. As the power of any body to emit light increases with its temperature, an inspection of the arc quickly confirms the statement made that the crater is the hottest part of the arc.

With the current strength ordinarily employed, the incandescence of the carbons extends to but a comparatively short distance from the tips. This is the region in which the burning of the carbons or the oxidation is most marked. After the arc has been maintained for awhile under the double influence of volatilization and oxidation, the ends of the electrodes assume a more or less irregular shape. This is shown in Fig. 1.

Careful observation, through the medium of smoked glass, of the conical-shaped ends of the carbons, will reveal minute globules of molten matter, scattered here and there over their surfaces. These are supposed to be molten drops of various mineral impurities in the carbon. The more nearly pure the carbon the fewer they will be. If an iron cored carbon, positive, is used, there will be observed tiny drops of molten iron on the tip of the negative.

In operating an arc, the crater does not maintain its position, but shifts from point to point on the surface of the positive carbon or electrode. This is explained by the following fact. As the carbon is consumed by volatilization and oxidation, the edge of the crater becomes unequally worn at different parts, and the tendency is for the arc to establish itself at the point where there is least space between the two carbons. In this way a new crater is temporarily formed. Impurities in the carbons also determine a different rate of volatilization with the result of the formation of the crater at the point where volatilization is most active. It is very essential for the best results, whether as an illuminant only or whether it is to be employed therapeutically as a minia-

ture sun bath, that carbons of the greatest purity should be used.

By reason of the shifting of the position of the crater from the above causes, the light becomes unsteady and flickering, which results in an unequal distribution over the surrounding space. This has been obviated in the practical operation of the arc by utilizing carbons of the smallest diameter compatible with the amount of current consumed in order to reduce the area over which the arc can shift, and also by the introduction into the centre of the carbon a core of softer carbon. By the use of such a core, there is secured the greatest liberation from the central portion, and the consequent formation of the arc at these parts. These are known commercially as cored carbons. Usually but one carbon is cored, viz., the positive, as this is the seat of the crater, where the trouble arises with the ordinary carbons. In therapeutic work cores of iron, an iron rod passed through the centre of the carbon axially, or iron incorporated into an appropriate solidified mass are used. As iron when volatilized is extremely rich in chemical activities, its use is very desirable where the production of the maximum of ultra-violet rays is desired.

By reason of the rapid vaporization of the positive carbon it wastes twice as fast as the negative. This is the reason why it is necessary where large currents are used that the positive carbon should have twice the thickness of the negative carbon.

The arc proper is separated from the crater by a thin layer of carbon vapor, which has in all probability a high specific resistance. This layer of carbon vapor is of bulbous shape, violet in color and consists of conducting carbon particles condensed from the vapor.

The region around the arc in which the combustion is going on is distinguished by a green flame. Eighty-five per cent. of the light of the arc comes from the positive carbon, 10 per cent. from the negative, and 5 per cent. from the arc proper. Although the temperature of the arc is high, its

emissive power is feeble. The sources of light in the arc are (1) the crater, (2) the remainder of the hot end of the positive carbon, (3) the white hot spot on the negative carbon, (4) the remainder of the hot end of the negative carbon, (5) the arc vapor.<sup>1</sup>

The light emitted by these 5 sources together is called by Mrs. Aryton the light of the arc; while the light emitted by the arc proper she terms the vapor light, or the light of the vapor.

It is this vapor light which concerns the physician. As has been shown the color is that of violet, and from it proceed the short high frequency wave lengths or ultra-violet rays as well as the blue and violet, all of which have well-marked actinic properties. The longer the arc the more of the vapor mist. This means that the arc mist would be cooler as the average temperature of it is lowered by increasing the length of the arc. As the carbons are drawn apart, the arc stream tends to spread out further. The amount of light emitted by the unit area of the crater is practically the same when the power supplied to the arc is raised sixty-fold, and is independent of the size of the carbons and of the length of the arc. This was demonstrated by Violle.<sup>2</sup>

By increasing the current, with given carbons, at a given distance apart, the size of the crater is increased, and therefore the total amount of light emitted, but there is no increase of the amount per unit of area. If the temperature of the crater is that of the volatilization of carbon, it could not be increased, provided the pressure remained constant, however greatly the power applied was increased, and therefore it would not be expected that there would be more light emitted per unit of area. The principle involved is the same as in boiling water. The temperature of boiling water cannot be raised even by using a more powerful source of heat. The

---

<sup>1</sup>Aryton, p. 314.

<sup>2</sup>Ganot's Physics, p. 869.

temperature of the space between the carbons may be much higher than that of the surface in the same way that steam can be superheated above the point at which it is evaporated, there being in fact, no limit to the possible rise in temperature. Since the current is conducted by that highly heated vapor present, it is to be expected that such a conductor will be heated by the passage of a current the same as a solid or a liquid.

An electro-motive force of more than 40 volts, usually from 40 to 50, is necessary to maintain a steady arc between carbon points, giving a current of 10 to 15 ampères. It is generally assumed that this high E. M. F. is needed because of a back E. M. F. of 39 volts at the crater in the positive carbon. A large amount of energy is needed there for the vaporization of the carbon. This high apparent resistance of the arc, obtained by dividing the difference of potential by the current, is due to this back E. M. F. This counter E. M. F., which is variable with the current and other conditions, is generally attributed to a combination of two or more separate electro-motive forces, one due to the volatilization of the carbon, another due to the thermo-electric effect at the positive carbon, and perhaps still another thermo-electric potential at the negative carbon.

According to J. J. Thomson this potential difference is determined by the rate at which the negative electrons are given off. An arc of 3 mm. or  $1/10$  of an inch, has a resistance something less than an ohm. For a 10-ampère arc from  $1/16$  to  $1/8$  of an inch in length, the resistance is given at from  $1/10$  to  $1/2$  an ohm, while roughly speaking a resistance of 5 ohms for an arc one inch in length is given. The true length of an arc is from the bottom of the crater to the tip of the negative, not from the edge of the crater which is only its apparent length. This resistance of an arc, like that of any other conductor, increases with its actual length, and diminishes with its cross section. It has been suggested by Mrs. Ayrton that the film of carbon vapor close to the crater has a relatively high specific resistance and that the

temperature of the crater may be accounted for by its resistance rather than assuming a large back E. M. F.

Care should be taken in the adjustment of carbons. If they are too far apart, or too close together, the arc is noisy and fluctuating, and if the distance between them is too great the arc flares and flickers from side to side. Thus the *chemical combustion is increased*, with the result that the electric efficiency is reduced when the distance is too small, while the illuminating power of the arc is reduced by each carbon acting as a screen for the other, and the crater is diminished in size. By the reduction in size of the latter, the efficiency of the arc in therapeutic work is diminished, for the longer the arc and the larger the crater, the greater number of the short high frequency waves or ultra-violet light, intrinsically so valuable. This is because of the increase in chemical combustion. The longer arc offers a greater opportunity for the air to oxidize the carbon. The longer the arc the greater the E. M. F. required, and when more than 80 volts is used there is a great increase in the quantity of violet light given off. This is not well for purposes of illumination, but it is just what is needed for therapeutic work.

There is no difference in the appearance and consumption of carbons when an alternating E. M. F. is used, for by reason of its physical nature changing at both signs, positive and negative, with each alternation, there is no polar action as with the direct current. Each carbon maintains a rounded appearance, there is no formation of a crater and they are consumed at the same rate. The upper carbon wastes 8 or 10 per cent. faster than the negative, due to the ascending heat. When an arc is fed by an alternating current the arc is no longer a continuous flame, but is lighted and extinguished at every reversal of the current.

The candle-power of an electric arc depends upon its volt-ampères. For example, an arc with a pressure of 50 volts, and giving a current of 15 ampères, expends a power of 50 volts  $\times$  15 ampères, or 750 volts. This is equivalent to about 1 horsepower. As .75 of a volt is required to produce

the light of one candle, 750 volts will give 1,000 candles. Therefore if one is operating two arc lamps connected in series, with a pressure of 50 volts and a current of 15 ampères, in an electric arc bath, in which the patient lies nude, the body is bathed in a sea of light of 2,000 candle-power, and while to each square inch of surface but a small amount of light energies are delivered, there is a very considerable total of energy expended by reason of the very large square inch area exposed, i.e., the entire body. This effect is increased by reason of the cabinet enclosure and the white enamelled walls, providing as they do the best of reflecting surfaces.

In the Light Institute at Copenhagen, under the direction of Finsen, lamps of 20,000 candle-power are used. This means a tremendous volume of light, and with the increased current, 80 ampères and upwards, and the increased diameter of the carbons or electrodes, there is afforded a larger crater, which means a larger unit of area. And as it is the light emitted by the *arc* proper, called the vapor light or the light of the vapor,<sup>1</sup> which is so rich in chemical activities or short and high frequency waves, from the blue to the ultra-violet, the advantage of lamps of high candle-power can readily be seen. This quantity of light, so active, chemically, is essential in the treatment of well-organized and deep-seated skin conditions, as in long-standing cases of lupus vulgaris for example.

Quantity Necessary as with the Continuous Current.—The good results obtained from the selected chemical activities of the electric arc from lamps of high ampèrage and enormous candle-power, in the treatment of deep-seated and long-standing lesions, is comparable to the use of the continuous current, in long-standing and deep-seated pathologies as for example, exudates about the sheaths of tendons and the articular surface of joints.

From the use of currents of high potential and high fre-

---

<sup>1</sup>Aryton, p. 314.

quency it is not possible to obtain results as quickly in these cases as with the chemical action of the continuous current. There is a chemical action with both, but there is not that *quantity*, coulombs per second, with the one that there is with the other, which is essential to the production of the changes necessary to the absorption of the organized exudate. This is likewise true of condenser lamps, excited by high-tension coils or static machines, and also iron electrode lamps of low ampèreage. The chemical activities thus produced have not the *quantity* of the larger lamps, which is absolutely essential in the most thoroughly organized skin pathologies or wherever a deep-seated action is required. For more recent and superficial conditions the lamps of lesser *quantity* are equally good.

But lamps of lesser ampèreage do good work if the *light* emitted by the *arc* proper or vapor light is utilized near its source. By their passage through air, the precious ultra-violet waves are absorbed to a greater or less degree, according to the distance. The same is true of that portion of the ultra-violet region known as the bactericidal region when passed through water. It is estimated that four-fifths of the bactericidal activity is lost in passing through but 2.5 cm. of water. And as in the Finsen apparatus the condensing lens is at least three feet from the vapor light emitted by the arc proper, and passes through from 4 to 6 inches of water, there is a very considerable loss. With the enormous candle-power of the lamps used by Finsen, this is of little moment, but with the lamps of lesser ampèreage commonly used in office work, it becomes a matter of very great moment. In using lamps of lesser ampèreage, without water-cooling cylinders and near the arc itself, the difference is not proportional to the diminished candle-power, as in the latter instance few of these short high-frequency waves are lost as compared with the higher candle-power lamps where the beam is not only used farther from its source, but filtered through water. All the energy of the light from the arc, whether in the form of light, heat

or anything else (gases produced), radiates from the middle of the crater.

Measurements which have been made show a correspondence with the compound radiant energy of the sun's surface, viz., at the rate of 100,000 horsepower to the square meter.

There is always a definite ratio between the energy of any body and its temperature, therefore, if the radiant of two bodies is the same, so is their temperature. That of the radiant dot of the electric arc is nearly  $6,500^{\circ}\text{F}$ . This would indicate that the temperature of the sun's surface is the same, in view of the fact of the correspondence in measure of energy.<sup>1</sup>

It has been shown that an increase of pressure does not increase the temperature of volatilization. An increase in the current strength or the quantity of electricity which passes per second through the arc has no increase upon the temperature of the arc, and only tends to increase the amount of carbon volatilized, and, therefore, the area of the crater. This affords, as has been pointed out, an increase in the unit of area.

The temperature of boiling carbon is  $3,500^{\circ}\text{C}$ ., and is the highest which has yet been produced artificially. If conditions existed under which a temperature in excess of boiling carbon could be reached, it would mean a source of light richer in the visible and invisible frequency of light, or short and high frequency vibrational activity; a light not only of higher intrinsic energy, but of greater total energy, capable of profounder chemical action, the therapy of which is yet unknown. But iron which volatilizes at a temperature of  $1,600^{\circ}\text{C}$ ., although volatilizing at a lower temperature, has a high rate of vibrational activity, and gives a spectrum rich in the ultra-violet frequencies, but it does not vibrate at the slower rate that gives the visible chemical rates and those below, and the light, therefore, while possessing the

---

<sup>1</sup>Professor Dolbear. Press clipping.



high intrinsic energy does not possess the total or complex of energy essential to the best therapeutic work. In the much lower temperature at which volatilization takes place is to be found the reason why, when an iron-cored carbon is used for the positive electrode in the formation of an arc, the production of heat is so much less than with pure carbon, which volatilizes at a temperature of  $3,500^{\circ}\text{C}$ . or  $6,332^{\circ}\text{F}$ . And this lower temperature in connection with its extreme richness in ultra-violet rays, i.e., inherent rate of vibration, renders carbons with iron cores very desirable for the therapist. Iron is used alone in some arc-light mechanisms for therapeutic purposes. Clinically, however, the better results are obtained with the lamps of larger ampèreage where carbons or carbons cored with iron are used, than with lamps of small ampèreage with iron electrodes. As the most intense chemical combustion is the seat of the highest chemical activities, there is every reason to believe that the higher temperature at which the volatilization of the carbon alone or that of carbon combined with iron, is the one at which the greatest quantity of ultra-violet rays are given off, and, therefore, is the better source for therapeutic work.

Bodies become luminous at a temperature of  $500^{\circ}\text{C}$ . or  $932^{\circ}\text{F}$ ., but the increase of luminous intensity increases with the temperature. This will not be true of the *cold light* of the future, which will be a light devoid of temperature and containing the maximum of visual rays. The efficiency of the light of the firefly is practically 100 per cent.; in other words, the firefly does not seem to emit any frequency of light vibrations, which are not within the limits of visibility; while all practical mechanisms for the production of artificial light for illuminating purposes requires that the temperature of the luminous body be raised to such a point that the frequency of oscillation of its molecules is such as to cause the emission of light as well as heat. This means much more dark heat than luminous heat, and the work of Tesla, of McFarland Moore, of Cooper Hewitt, in the direction of producing luminous activities without thermal, will unques-

tionably result in a cold light, as the illuminating power of the future.

Professor Langley<sup>1</sup> states that the Cuban firefly spends the whole of its energy upon the visual rays without wasting any upon heat, and is some 400 times more efficient as a light producer than the electric arc, and even 10 times more efficient than the sun in this respect.

The luminous efficiency of the arc lamp is practically as high as that of any known artificial source, being about 13 1-3 per cent., while it is nearly 3 times greater than that of the normal incandescent filament, and about 6 times greater than that of oil or gas flames.<sup>2</sup>

In a consideration of the electric arc for therapeutic purposes the phenomena which take place in the arc mist during the activity of the arc are not only of interest but importance. Since Sir William Abney<sup>3</sup> first announced that the temperature of the crater was that of volatilization of carbon, it has never been doubted but that the stuff of which the arc was composed consisted chiefly of the vapor thus volatilized. It leaves the positive carbon without doubt as vapor, but its temperature must be lowered by the cooling action of the air. It must therefore, be considered at a very short distance from the crater. Of this there can be but little doubt, and in her work on the electric arc, Mrs. Aryton expresses it as her belief that the vapor, in leaving the crater, acts just as steam does when issuing from the mouth of a kettle. Through a short distance, small enough for its temperature to continue unaltered, it still remains vapor; at a greater distance it is condensed into carbon, fog or mist. The true vapor is probably invisible, just as water-vapor is (the space that is always between the arc and the crater confirms this view) but the mist is visible. The resistance of true vapor is very great, and consequently the resistance of the thin layer of the vapor that lies over

---

<sup>1</sup>Electrical World and Engineer, N. Y.

<sup>2</sup>Houston and Kennelly, Electric Arc Lighting.

<sup>3</sup>Aryton, p. 356.

the crater is so great as compared with that of the remainder of the arc, that it is usually supposed not to be a resistance at all but a back E. M. F. According to Stark,<sup>1</sup> there is a back or counter-electromotive force of the arc when the anode is very hot, and it represents the sum of the internal electromotive force of the anode and cathode, but is much smaller than the minimum tension. The latter is not due to the counter E. M. F., but to the fact that a minimum of work must be done at the cathode in order to produce the radiation of negative electrons in sufficient density.

By the passage of the current through this great resistance, the heat evolved (the greater the resistance, the greater the production of heat) is sufficient to volatilize the surface of a part of the positive carbon, and thus to keep up the supply of vapor.

The part of the surface thus volatilized becomes hollow with a short arc, and the crater is formed by the action of the heat supplied to it by the thin layer of vapor over its surface. According to this theory of the arc, the temperature of any horizontal section of the mist must depend upon (1) the temperature at which it left the crater, (2) the constant supply of heat conveyed to it, by radiation from the crater, (3) the heat evolved by the passage of the current through it, and (4) the cooling effect of the surrounding air.

The *average* temperature of the mist must be lowered by lengthening the arc, and consequently its average density must be increased.<sup>2</sup>

The following facts indicate that the arc mist absorbs an appreciable amount of the light emitted by the crater: (1) That this mist shares with candle and gas flames the power to hide anything placed behind it, as if it were opaque, not due to too much light, but absence of light. (2) The acknowledged and proved existence of solid par-

---

<sup>1</sup>Annales der Physik No. 12; London Elec., Dec. 4, 1904.

<sup>2</sup>Aryton, p. 356.

ticles in it. (3) Its casting a shadow which can hardly be due merely to refraction.<sup>1</sup>

All of these facts concerning the mist are of both interest and importance in connection with the use of the chemical activities of light in therapeutics, as the evidence points to the vapor or mist as their source.

The spectrum of the arc is not only rich in the luminous and thermal activities, but is especially rich in the chemical activities. And by the chemical activities is meant not only those of the ultra-violet region, so much talked of, rich as that region is in intrinsic energy, but the violet and blue violet as well.

The Spectra of the Electric Arc.—The spectra which are formed by artificial lights rarely contain all the colors of the solar spectrum; but these colors are always found in the solar spectrum and in the same order. Their relative intensity is also modified. The shade of color which predominates in the flame predominates in the spectra of that flame. In yellow, red and green flame, red, yellow and green predominate in the spectra. It was shown by Sir W. Abney,<sup>2</sup> as will be seen by tables of light values given below, that the crater light of the electric arc was very like sunlight, but that it had an excess of orange and green rays and a slight deficiency of blue. Taking the intensity of red as the unit, the composition of direct sunlight, of the carbon arc, and of gaslight, were found by Abney respectively, as follows :

Sunlight.	Carbon Arc.	Gaslight.
Red..... 100	Red..... 100	Red..... 109
Green..... 193	Green.... 203	Green.... 95
Violet.... 228	Violet... 250	Violet.... 27

The hardness of the carbon, the material of the core, the current and the voltage, all influence the composition of the electric arc. By hardness the maximum temperature

<sup>1</sup>Aryton: The Electric Arc.

<sup>2</sup>Report on the Action of Light on Water Colors, c. 5455, 1888, pp. 25 and 69.

of the crater is determined, while the current and voltage alter the properties of the light fluxes coming from the yellow crater and from the violet arc stream. The vapor of the core acts to color the light as well as to determine the volatilization point of the crater.

Abney's spectroscopic examinations were made so as to interpose as little of the arc as possible between the spectroscope and the crater, and in this way he secured the rays from the crater only. This crater light when seen through a small quantity of mist is yellower than sunlight, but when it has penetrated through a very long arc, the color is a bright purple. This is very commonly shown in the purple coloring of the opalescent globes surrounding the arc lamps of the street. This purple coloring is evidence of great chemical activity. It differs only in degree, not kind, from the violet coloring of X ray tubes and the tubes of glass containing radium. The light of the crater becomes tinged with violet or purple as it passes through the arc, and the tint deepens as the arc is lengthened. In this, then, must be found the reason for the establishment of a long arc when the maximum of ultra-violet rays is required. For next the violet come the higher frequencies of the ultra-violet region.

If a light becomes colored by passing through screens of colored glass, blue, red or green, for example, the explanation is to be found in the fact that the glass interposed, whatever its color, absorbs certain colors and permits other rays to pass. For example, with blue glass, the rays giving other colors are absorbed, therefore a blue glass screen gives the maximum of chemical activities below the ultra-violet region, but not the ultra-violet, however, as glass is not transparent to ultra-violet frequencies, i.e., below 30 micro-centimetres.

The following is a very rational explanation of the phenomena which occur in the electric arc to produce the intense violet mist. The arc, except a thin layer quite close to the crater, consists of a mist of solid carbon particles, which are

continually forming and falling, surrounded by burning gases. The vapor and gases must absorb a minute, possibly an inappreciable portion of the light that issues from the crater. If this were all, there would probably be no maximum of light with a given length of arc, but the solid carbon particles have to be reckoned with. The whole quantity of light absorbed might still be too small to notice, if the light simply passed through each of these particles it encountered and suffered only the small amount of absorption that would naturally occur.

But a ray of light when it encounters a red hot particle is not only refracted, but some of it is reflected, so that each ray may be reflected from particle to particle, and traverse the mist hundreds of times before it finally emerges. At each reflection and refraction part of the light that the carbon particle is capable of absorbing is absorbed, and according to physical laws, a ray that has suffered much internal reflection must emerge in a different state from that in which it left the crater.

If the carbon particles were capable of absorbing the orange light and a certain amount of the green, permitting at the same time the passage of the violet light, then each successive reflection or refraction would result in more violet, while that which had encountered many particles would be entirely violet. A dazzlingly brilliant light is not given by incandescent gases alone, and in looking at the arc mist only, screening off the whole direct light from both carbons, the part of the crater light transmitted to the eye from the solid particles, entirely swamps the feeble light emitted by the gases, and a brilliant violet or purple light is perceived. In this way is the brilliant light of the arc alone accounted for.

A simple experiment shows that the light emitted by the arc *mist* is violet, while that emitted by the crater and the white hot spot on the negative carbon is white. Take a thin metal plate containing a horizontal slit,<sup>1</sup> about 1/16 inch in

<sup>1</sup>Aryton, pp. 358, 359, and 360.

width, hold it vertically near the arc, so that the slit is about equidistant from the ends of the two carbons. Have a vertical white screen a foot or two away upon which to receive the light from the arc that passes through the slit. This light will form three horizontal bands on the screen, the upper and lower ones white, and the middle one of a bright violet. The slit corresponds to a pinhole elongated horizontally, therefore the upper white light proceeds from the negative carbon, the lower from the crater, and the middle violet band is lighted from the mist.

Or again, the upper carbon and part of the arc may be shaded with any opaque body, one's hand, for example. The shadow on the screen is edged with a broad band of reddish violet and represents the portion of the screen that is illuminated by the mist and the negative carbon alone, the red-hot part of the carbon gives the rosy tinge. Below the band is the part illuminated by all three sources,—crater, mist and white hot spot, and this naturally looks quite white when compared with the violet spot.

It is concluded by Mrs. Aryton, whose experiments are quoted, that the crater light is far yellower when emitted than when measured, and as the use of it therapeutically corresponds more nearly to the position of the photometer when it is measured, it follows that the highest chemical activities are easily available for such purposes.

When an arc is lengthened, the arc mist is cooler on the whole and under these circumstances there would be more solid particles, and each ray stands a better chance therefore of encountering one or more of these particles before emerging. Thus, more of the light on the whole would be absorbed, and more of the rays robbed of all the light the particles were capable of absorbing before emerging, so that on the whole, the light would be more violet than with a shorter arc, as it actually is. Every arc-light mechanism used for therapeutic purposes should therefore be adjusted, for as long an arc as its automatic feed arrangement will

permit, in order to secure the maximum violet and ultra-violet rays.

In drawing a long arc, there is ample room for lateral spreading, therefore its resistance is capable of being markedly diminished by an increase of current strength. By spreading laterally in all directions, the cross-sectional area is increased, and an increase in resistance by reason of the length of the arc may be more than compensated by the decrease in its resistance attendant upon the increase in the area of the cross-section. This diminished resistance in a long arc, from which the highest chemical activities are secured, means diminished heat.

Such an arrangement is impractical when the arc is used for illuminating purposes, as "almost the whole of the increased power that has to be supplied to the arc when it is lengthened, is swallowed up by the mist, and is practically wasted. And the ideal condition where illumination only is desired would be to have the carbons nearly touching were it not that the negative carbon stops some of the light."

Professor and Mrs. Aryton, as a result of a series of experiments, combined with careful observation and exact photographic records, found that when a direct current silent arc is maintained between vertical carbon rods, the positive carbon being uppermost,—

I. The tip of the positive carbon is white hot, and the tip of the negative has a white hot spot on it.

II. A white hot crater forms in the end of the positive carbon, and a more or less blunt point forms on the end of the negative.

III. The space between the two is filled by a violet light, the shape of which is defined by a shadow, which in its turn is bounded at its sides by a green light.

IV. The ends of both carbons are tapered, and the length of the tapering parts is increased both by increasing the current and by shortening the arc.

V. The diameter of the crater increases as the current increases, and also as the length of the arc increases.



VI. With uncored carbons, the violet part of the arc is bluer, and all parts of the arc are larger than with cored carbons.

VII. With uncored carbons, the violet part of the arc is of the form of an oblate spheroid when the arc is short, gourd shaped when it is long and the current is very small.

VIII. With cored carbons, the violet part is of the form of an oblate spheroid when the arc is short, gourd shaped when it is long, and sometimes almost of the shape of a figure 8 when the arc is very long for the current flowing.

IX. When the negative carbon is cored, a crater is formed in the tip exactly as if it were a positive carbon.<sup>1</sup>

Hissing Arcs.—It will be noted in operating electric arc mechanisms, that at times the arc gives out a hissing sound. This has been the subject of elaborate study, investigation and experiment by Mrs. Aryton, who has shown that the real, crucial distinction between a silent and a hissing arc is produced by the crater becoming too large to occupy the end only of the positive carbon, and by its, therefore, extending up its side. When the crater occupies the end only of the positive carbon, the arc is silent; but when it not only occupies the end but extends up the side as well, the arc hisses.

The extension of the crater then is the cause, and this extension is due to the presence of air. When an arc is first formed there is always a hissing sound which is due to the presence of air around the carbons when they are cold, so that when the crater is first made its surface must combine with the air; just so when it hisses it is due to an inrush of air into the arc. Hissing is avoided by the use of enclosed arcs, preventing thereby access of air to the arc, but in therapeutic work enclosed arcs should never be used because of the intervention of the glass enclosure.

A hissing arc is accompanied by a sudden diminution of potential difference. This diminution is due to the oxygen in the air getting directly at the crater and combining with

---

<sup>1</sup>The Electric Arc, Mrs. Aryton.

the carbon at its surface. No such effect is produced by nitrogen, carbon dioxide or hydrogen, but the same is true of air showing that this diminution of potential difference in a hissing arc is due to the presence of oxygen. With the humming and hissing a green light appears in the crater and with hissing, clouds partially cover the crater; and the carbon vapor becomes flattened out between the carbons.

The student who is interested in the phenomena of the electric arc will find Mrs. Aryton's study of it most interesting.

*Alternating-Current Arcs.* — Alternating-current arcs may be used for all therapeutic work other than with condensing or focal lenses as in the Finsen tube.

This exception is due to the fact that in an alternating current the direction of the flow is constantly changing and each carbon becomes alternately positive and negative.

In an alternating-current arc there is no crater formed at the end of the positive carbon, nor opposing nipple-like projection on the end of the negative. There is therefore a different distribution of light and the rate of the consumption of the carbons is approximately equal.

Alternating-current arcs are considerably influenced by the frequency of the alternations. If the frequency is below 35 periods or double reversals per second, the arc distinctly flickers. This produces an unpleasant varying visual effect owing to the rapid extinction and production at each pulsation of the current. A frequency of about 60 cycles or 120 reversals per second is generally regarded as the most suitable.

If the frequency is above 70 cycles or double reversals per second, alternating arcs develop a tendency to a distinct humming note which at higher frequencies becomes annoying. But 35 to 40 volts pressure are required by alternating-current arcs. An alternating pressure of 35 volts means a maximum pressure of about 50 volts in each wave, or if an E. M. F., which rises to 50 volts at the peak of each wave be used, the effective E. M. F. will be about 35 volts. The real

pressure required is therefore practically the same for both continuous and alternating-current arcs. There may be a wide variation in ampèrage as with the continuous current but for an ordinary electric arc cabinet 15 ampère arcs are sufficient. In common with continuous-current arcs alternating-current arcs require a regulating lamp mechanism in order to maintain the carbons at a constant distance apart. The character of this mechanism is changed to meet the changed conditions, that is, an almost equal burning of the two carbons. Alternating-current arcs however can never be connected directly with the mains of the generator supplying alternating currents, as they can to the mains of the generators supplying continuous currents. An apparatus known as an alternating-current transformer must always intervene between the mains of the generator and the lamp mechanism. These transformers are provided with both primary and secondary circuits; the primary is connected directly with the generator at a comparatively high pressure 1,000 to 2,000 volts being very commonly used. The secondary circuit is connected with the arc-lamp mechanism or incandescent for that matter wherever installed, usually at a pressure of about 100 volts.

In the event of a single arc lamp being used the pressure is about 33 volts. If however a number of incandescent lamps have to be supplied, a pressure of 100 volts must be generated by the secondary coil of the transformer, but in order to keep this pressure down either a resistance or a choking coil must be introduced to cut the pressure down to 30 volts.<sup>1</sup>

The Influence of a Magnetic Field upon an Alternating-Current Arc.—The alternating-current arc has been shown recently to have characteristics peculiarly its own. C. H. Bedell<sup>2</sup> points out additionally its very interesting behavior when in a magnetic field. That any arc may be “blown out” by the approach of the poles of a magnet is a well-known fact. If

---

<sup>1</sup> Houston and Kennelly: Electric Arc Lighting.

<sup>2</sup>C. H. Bedell, Electric World and Engineer, Sept. 13, 1902.

a magnet of the horseshoe type be used, "blown out" correctly describes the phenomenon. If a bar magnet is used, the arc is forced out at right angles to the line of the magnet and not directly away from it, as the "blowing out" would lead one to suppose. The principle is the same as that which governs the action on wires carrying current on the surface of a motor armature, i.e., the direction of the flow of the current, that of the lines of magnetic force, and direction of movement are all at right angles to each other. If the north pole of a bar magnet be presented to a direct-current arc and the current flows down, the thrust will be to the right; if up, the thrust will be to the left. With an alternating-current arc, however, the two effects are combined, and the arc appears to have two wings. While these wings appear continuous, they do not exist at the same time, but follow the alternations of the current.

The appearance of the arc under the influence of the magnetic field is interesting, as the wings may easily be made to have an extent of 5 inches from tip to tip, and with an upward curve due to the currents of heated air. In attempting to photograph such an arc, it was found necessary to shield the lens from the strong violet rays of the arc proper, in order that sufficient exposure might be obtained on the wings. The ends of the carbons, as shown by the photograph, although brilliantly incandescent, do not appear to give out many chemical rays. A short exposure was made to suit the violet arc, and the result indicated that but little violet light was given out by the incandescent ends. The question, therefore, arises, is not the curve of illumination for actinic rays for any arc lamp quite different from the curve of illumination for visual rays? Graphic illustrations of the current curve, both before and after separation by magnet, are shown in Bedell's article.

Carbons and Methods of Arrangement.—As has been indicated in previous pages there are two classes of carbons used in arc lighting, viz., solid and cored. Their diameter varies according to the voltage and the current consumed.

For those in general use, the average resistance is 0.15 ohm per foot.

*Solid Carbons.*—These vary according to their purity, molecular structure and hardness. The best are known as the electra or Nuremberg carbons, and are manufactured in Germany.<sup>1</sup> The electra of domestic manufacture are not comparable to the Nuremberg carbons as to purity and hardness. The former resemble graphite in these respects. Carbons are very apt to be filled with impurities, all of which prevent the securing a true carbon spectrum. There may be an increase of the frequencies of one or another portion of the spectrum, by reason of such impurities. If impregnated with iron pyrites, for example, there will be an increase in the ultra-violet frequencies, which is not objectionable for considerable therapeutic work. Where iron is used, however, it is better it should be pure. Sodium, on the other hand, would give an increase in yellow.

*Cored Carbons.*—These are solid save for a hole which runs axially through the length of the carbon. This hole is filled with some material softer and more readily volatilized than the remaining carbon. Usually, it is a mixture of carbon and some metallic salt. The object of this core in illumination is twofold: (1) to decrease the voltage for a given length of an arc, or (2) to increase the length of an arc for a given voltage. Initially, this has the effect of reducing any irregularity in carbons or the feeding mechanism to a less percentage of the whole length. In addition, the core, by affording a plentiful supply of vapor, tends to maintain a stable condition of the arc. By the use of a cored carbon, the tendency is for the arc to remain located in one spot, i.e., at the core, instead of travelling in an irregular fashion all over and around the end of the carbon in an effort to establish the way of least resistance. The core does that, and thereby maintains a steady non-fluctuating arc. The core of a carbon may also be used for the pur-

---

<sup>1</sup>Imported by Hugo Reisinger, 71 Broadway, New York City.

pose of intensifying certain portions of the spectrum. This is very important in therapeutics where it is desired to increase the number of the highest chemical frequencies or ultra-violet rates of vibration. For this purpose carbons cored with iron are of great service. The ones manufactured in this country are inferior to those imported. The Nuremberg carbons are prepared with powdered iron incorporated into the mass which forms the core. When similar carbons are placed vertically one over the other, their relative consumption depends upon the amount carried off by: (1) volatilization and electrolytic action; (2) oxidation of the air; and (3) mechanical disintegration by air currents. Putting aside the oxidation of the air, the life of carbons of different diameters increases in proportion to their sectional area. To increase the conductivity of the carbons they are sometimes plated for about nine-tenths of their cylindrical surface with a thin layer of copper, the tip only being left uncoated. The primary object of the plating is to reduce the contact resistance of the carbons. A copper-plated carbon would secure to the spectrum the rates of vibration of copper in addition to that of carbon. Few of the copper lines are sharply defined, even on one side, and the spectrum, therefore, has a peculiar appearance. In the Bunsen flame cupric chloride produces a band spectrum extending over the whole field with the exception of the violet; the same spectrum is obtained with the metal if the flame contains hydrogen chloride. The absorption spectra of copper salts are not characteristic, as the compounds produce total extinction both in the red and violet. The addition of copper has no advantage therapeutically.

With the use of heavier currents from 50 ampères upwards, the carbons become hotter and are oxidized farther back from the ends, and, therefore, have longer points. Inside of the crater, the positive carbon wastes away by electrolytic action, and outside of the crater by the action of the air upon it. This wasting in an open arc is twice as fast for the positive as the negative. The consumption of the

negative is due to the oxidization of the air alone, according as its temperature is increased by the carbon particles deposited on it, and by the heat reverberated from the crater. The shorter the arc, or the closer the positive to the negative, the greater will be its heating effect upon it. In very short arcs the deposit of the particles of molten carbon or graphite is greater than with long arcs, so much so that the negative accumulates faster than it wastes away, and a nib or second point is formed on the negative which finally crumbles away. In the long arc these particles of boiling carbon float about and serve to reflect and refract the rays of light, thereby increasing, as has been pointed out, the violet and ultra-violet frequencies. Carbon that has been exposed to the temperature of the arc is turned to graphite. The tip of a negative will write as will a pencil, and the positive also shows some graphite.

The Arrangement of the Carbons of Arc-Light Mechanisms and Reasons Therefor.—The arc mechanism may be arranged with the electrodes in a perpendicular or vertical position, horizontally or at an angle varying from an obtuse to a right angle. In vertical arcs, the positive carbon is usually the upper one. The reason for this lies in the fact that the crater formed in the positive carbon by the volatilization of the carbon is the source of the most intense light, and by placing the positive carbon above, the light is thrown down. This is as a rule desirable for purposes of illumination. If it is desired to illuminate the space above rather than below the arc, the position of the carbons is reversed. In a horizontal arc, as in a marine search-light, for example, where a Mangin mirror or reflector is placed at the back of the arc, the positive carbon is placed in front of the negative, thus directing the arc toward the reflector and away from the object upon which the illumination is to fall. The reason for this is that all the emerging rays shall be parallel, in which condition their intensity is theoretically the same at any distance, but practically not, owing to unavoidable dispersion, due to the size

of the light-emitting surface, aberration in the reflector, and the refraction and absorption of the atmosphere. With the crater turned toward the front of the searchlight, all of its rays that did not strike the reflector would be divergent instead of parallel. The carbons in searchlights, as in projector lanterns, locomotive headlights, may also be inclined at an angle varying from an obtuse to a right angle. When the carbons are inclined away from an object so that the maximum rays at an angle of about  $45^\circ$ , from the axis of the positive carbon will be directed nearly horizontally at the point to be illuminated. This method is used, as will be seen in discussing apparatus and arrangement of mechanisms for therapeutic work. Besides being tilted the upper carbon is often set back somewhat out of line with the negative, which brings the crater at an angle without tilting the carbons. Arc-lamp mechanisms so arranged are very difficult to feed automatically and therefore are apt to be hand-fed lamps. In the various arc-light mechanisms in use for therapeutic work, the arrangement of the carbons differs. In the lamp used in the Finsen Light Institute at Copenhagen, with the Finsen tube, the carbons are arranged vertically and the tube, with its condensing lenses of quartz, is placed radially to this powerful arc, so that the light from the *arc* impinges upon the lens at the proximal end at an angle of about  $45^\circ$ . The well-known London Hospital lamp, originally the Lortet-et-Genoud lamp, has the carbons inclined at an angle of about  $45^\circ$ . This is theoretically the best position of the carbons, for the reason that the energies of the *light of the arc* proper, the vapor light, or violet mist is brought more directly opposite the quartz lens of the water-cooling chamber and is therefore carried more directly to the patient. In a vertical arc, the carbons may be "staggered" or the upper one set back somewhat out of line with the negative, as indicated, which brings the crater at an angle the same as when the carbons are placed at an angle, and renders it possible to utilize the light of the *arc* proper at its full value. The



objection to this position of the arc in therapeutic work is the necessity of using a hand-fed instead of an automatically fed mechanism. In the small iron electrode lamps, the electrodes are placed vertically. The construction of these mechanisms is such as to preclude any different position of the contacts.

Regulators of the Electric Arc.—For therapeutic work, as well as for the purpose of illumination, it is necessary that the light must be continuous. To this end it is not only essential that the current should be constant, but that the distance of the carbons must not alter. Therefore it is necessary to use some arrangement by which they may be brought together in proportion as they wear away. Two methods are used for this purpose: (1) hand regulators and (2) automatic regulators. The first is an arrangement of a screw, to be adjusted by hand and which regulates the position of the carbons in relation to one another as they are worn away. For therapeutic work this is unquestionably the most delicate method, but possibly necessitates more careful attention on the part of the operator than the second or automatic-fed mechanism.

Automatic Regulators.—There are two distinct classes of mechanisms employed in arc lamps: (1) those which maintain constant the distance between the electrodes, but do not keep the position of the arc fixed, and (2) those which not only keep the distance between the carbons fixed, but which also maintain fixed the position of the arc.<sup>1</sup>

In the first class of mechanisms but one carbon usually the upper or positive carbon is fed or moved; in the other class, both carbons are moved and in this case since the positive is consumed more rapidly than the negative the relative motions of the two carbons must be different. To the first class of mechanisms belong the ordinary type of arc lamps employed for street lighting. These same arc-light mechanisms are used therapeutically in arc-light cabinets.

---

<sup>1</sup>Houston and Kennelly, Electric Arc Lighting.

To the second class belong various projectors, searchlights or other apparatus employing reflectors or lenses. In the latter instance it is necessary that the arc shall be maintained at the focus of the reflector or lens. This is the case with the marine searchlight mechanism in use for therapeutic work. The feeding mechanism then in any form of arc lamp, in order to insure continuous operation must comply with the following 3 conditions: (1) It must bring the carbons initially into contact. (2) It must then separate the carbons to a suitable distance and maintain this distance. (3) It must cause or permit the carbons to approach when consumption or burning has rendered their separating distance too great.

There have been many arc-light mechanisms devised, and there are many in extended use. While they present minor differences, fundamentally they are practically the same, for all lamps suitable for series connections; that is to say, an electro-magnet in the main surface operates a mechanism which effects the separation of the carbons, while another electro-magnet placed in the shunt circuit, effects an approach of the carbons.

The Gases of the Electric Arc.—With a powerful current a very dull incandescence is observed, accompanied by a bluish lambent flame, over the ends of the carbon electrodes when the gap is from  $\frac{1}{2}$  to  $\frac{3}{4}$  of an inch in length. The origin of this flame is exactly the same as that which may be observed playing over a hard-coal fire, when by reason of an insufficient supply of air it has not reached full incandescence. This is due to the burning of the carbon vapor in the oxygen of the surrounding air. Chemically, carbon undergoes two distinct forms of oxidation, producing carbon monoxide, as in the case of the hard-coal fire, and also the ends of the carbon in the electric arc; and a second but more complete oxidation, carbon dioxide or carbonic acid. It is believed that in the interior of the arc no oxidation of carbon vapor occurs, not only because the vapor fills this interior space,

and, therefore, displaces the air, but because the temperature of the disengaged vapor is so high that it is above that at which carbon monoxide can exist, without *dissociation* or separation into carbon and oxygen.<sup>1</sup> The inner portion of the arc stream which consists of a violet hub of incandescent carbon vapor, is surrounded by a thin non-luminous portion where the combination of the carbon with the oxygen of the atmosphere in dark flame takes place to form carbon monoxide (CO). As the temperature is above that at which the monoxide of carbon can exist without dissociation into carbon and oxygen, it follows that there is such a dissociation or separation and the oxygen thus released is, in turn, enveloped by a layer of luminous flame in which the carbon monoxide burns to carbon dioxide (CO<sub>2</sub>). Besides this combination there is an action on the nitrogen of the air by oxygen set free and uncombined forming an oxide of nitrogen. From the characteristic odor as well as from the powerful deodorizing or disinfecting nature of the arc when in activity, it has been supposed that ozone was given off to some extent during the activity of the arc. This is not the case. The odor is attributed to the presence of small quantities of hydrocyanic acid gas. None of these gases are given off in sufficient quantities where the voltage of the arc does not rise above 55 in air to be injurious. On the contrary, judging from clinical results they would seem to be helpful, for as will be shown in the use of the arc therapeutically, voltage 45, two in series 15 ampères each, there is evidence of an immediate oxidizing action upon the respiratory mucous membranes, when patients with bronchial asthma, bronchitis, tuberculosis pulmonalis or catarrhal colds are exposed to their activities. So true is this that the author has for the past 11 years used an electric-arc cabinet, constructed in such a way as to permit the patient to lie fully within it, head as well as body, with excellent results. Whether there is an

---

<sup>1</sup>Houston and Kennelly, *Electric Arc Lighting*, pp. 21-24.

anæsthetic effect produced upon the mucous membranes by the action of carbon dioxide is an open question. The relief from cough is established at the first exposure and persists with the continuance of the treatment at successive periods of time, nor is there ever any indication of any irritating or untoward effect upon the mucous membranes.

The production of the oxides of nitrogen in air by an active arc has been fully established by Charles S. Bradley,<sup>1</sup> both by experimental work and successful practical application of the principle, to the commercial production of atmospheric products. This is justification for the belief that the outcome of all the combinations and recombinations which take place during the burning of the arc is the formation of oxides of nitrogen in the air. The same is true of the disruptive discharge from a static machine or a high tension coil, but with that there is also a production of ozone while the brush discharge produces ozone and no oxides of nitrogen. Therefore, if it is desired to produce ozone the brush or convective discharge is efficient, if oxides of nitrogen, the electric arc, while the disruptive discharge is unsuitable for the one or the other. If it be true that there is a momentary production of ozone (due to liberation of oxygen molecules, which temporarily unite with  $O_2$ ) at the breaking of an arc, i.e., when the physical conditions of the arc correspond to the condition of strain in the air, before the actual lightning discharge, there is then a reason for the belief that there is more ozone produced by an alternating-current arc than by a direct one, for by reason of the alternations there is a constant breaking of the arc.

Negative Corpuscles, Carriers of Negative Electricity from Incandescent Metals and Carbon, their Relation to the Arc Discharge.—From incandescent metals and carbon there is a very rapid escape of negative electricity. J. J. Thomson<sup>2</sup>

---

<sup>1</sup>Personal communication.

<sup>2</sup>J. J. Thomson: Conduction of Electricity through Gases, pp. 164, 165.

in his investigations on the conduction of electricity through gases, shows that this electrification from a hot wire is conveyed by the same carriers as the cathode rays, i.e., by "corpuscles," "those small negatively electrified bodies which in all of the phenomena investigated by him, were found to act as carriers of negative electricity in high vacua."

"Corpuscles" are projected, according to his theory, from an incandescent metal or glowing piece of carbon, the rate of emission being very much greater with a carbon than with a platinum filament, amounting in the former when it is at its highest point of incandescence, to a current equal to several ampères per square centimetre of surface. In like fashion the sun and, probably, any luminous star is to be regarded as a source of negatively electrified particles, which stream through the solar and stellar systems. When corpuscles moving at a high speed pass through gas, they make it luminous. In the same fashion when the corpuscles from the sun meet the upper region of the earth's atmosphere, luminous effects are produced. These corpuscles are disseminated through metals and carbon, not merely when they are incandescent, but at all temperatures; they are so small that they are able to move freely through the metal, and may thus be supposed to behave like a perfect gas contained in a volume equal to that of the metal. The corpuscles are attracted by the metal, so that to enable them to escape into the space surrounding it they must have sufficient kinetic energy to carry them through the layer at its surface, where its attraction of the corpuscles is appreciated.

If the average kinetic energy of a corpuscle, like that of the molecule of a gas, is proportional to the absolute temperature, then as the temperature increases, more and more of the corpuscles will be able to escape from the metal into the air outside.

The phenomena connected with the discharge of electricity from incandescent bodies Thomson<sup>1</sup> found to indi-

---

<sup>1</sup>J. J. Thomson: *Conduction of Electricity through Gases*, pp. 424, 425.

cate a different explanation of the arc discharge. An incandescent body, such as a piece of carbon, even when at a temperature far below that of the terminals in the arc, discharges, as has been stated, negatively electrified corpuscles at a rate corresponding to a current of the order of an ampère per square centimetre of hot surface. If a piece of carbon were maintained independently at the same high temperature and used as the negative electrode, a current could be sent through the gas to another electrode, whether this second electrode were hot or not. Suppose the anode to be cold, then the current would be entirely carried by negative ions, these would cause the electric force to increase as we pass from the cathode to the anode resulting in a rapid increase of current with the potential difference. If the anode then becomes hot and has some gas in contact with it which can be ionized, yielding a supply of positive ions, the current will no longer be carried entirely by negative ions, though inasmuch as the velocity of the negative ion at these high temperatures is very much greater than that of the positive, by far the larger part of the current is carried by the negative ions. The distribution of potential between the electrodes is very much modified, however, by the presence of the positive ions. The latter diffuse into the region of the discharge until they are sensibly equal in number to the negative ions; when this is the case there is a very uniform electric force between the terminals, except close to the electrodes. The distribution of potential between two hot electrodes bears a great resemblance to the distribution of potential between the terminals in the arc discharge. By the high temperature in the interior of the metal, an electric force is produced which drives the electrons toward the anode.

It is believed by Thomson that the arc discharge is similar to the discharge between two incandescent terminals, the only difference being that in the flame the temperature of the terminals is maintained by independent means while in the arc it is maintained by the work done by the discharge

itself, which requires that the potential difference between the electrodes also the current passing should not sink below certain values. On the other hand maintaining the temperature by external air, the smallest potential difference is required to send a current.

Regarding the arc discharge from this point of view then, the cathode is bombarded by the positive ions, which maintains its temperature at such a high value that negative corpuscles come out of the cathode. The anode is bombarded by these negative corpuscles which carry by far the larger part of the arc discharge and is thus kept incandescent. They also ionize either directly by collision or indirectly by heating the anode, the gas or vapor of the metal of which the anode is made, producing in this way the supply of positive ions which serve to keep the anode hot. The essential thing in the arc discharge is the hot cathode as it has to supply the carriers, negative corpuscles, of the greater part of the current in the arc. As the metal or the carbon terminal of an arc volatilizes, the arc goes through a mixture of the vapor of the metal and the air. The negative corpuscles of Thomson serve to produce on ionization of this gas or vapor and of the air itself, a condition which to the author's mind is comparable to the action of the negative corpuscles emitted by the glowing carbon of the photosphere of the sun upon its gaseous envelope.

The arc is deflected by a magnetic field in the same direction as a flexible conductor would be if it carried a current flowing in the same direction as that through the arc.

The curved course corresponds to a longer path and the effect of the magnetic field on the potential difference is of the same character as an increase in the length of the arc, and just as it is possible to extinguish an arc by increasing its length, so the arc can be blown by the application of a strong magnetic field.<sup>1</sup>

The ionic theory of the electric arc has been investigated

---

<sup>1</sup>Thomson, p. 431.

to a considerable extent by Stark.<sup>1</sup> In order to make the matter more simple he began his investigations with the mercury arc which is longer than the carbon. Four distinct parts are distinguished, viz: (1) The brilliant brush issuing from the white hot depression in the cathode, (2) the dark space, (3) the positive light column and (4) the anode layer. The arc light involves the evaporation of the cathode or negative carbon as has been stated, but this is not necessarily involved by the glow discharge. Nor is it essential that the anode should emit vapor, as is the case in the carbon arc.

In all gaseous discharges, electrons, positive atomic ions, and molar ions have to be distinguished.

Negative electrons play a very important part in a Bunsen flame. They are even more predominant in the higher temperature of the electric arc, as is shown by the susceptibility of the arc to magnetic deflection and the readiness with which it follows every variation in the current. This is owing to the great nobility of the electrodes. The impact of the electrons produces positive and negative ions from neutral molecules at the anode and in the positive light. In the glow discharge the phenomena are reversed, whereas in the arc the negative electrons are produced from the cathode by electrification, and not from the gas by ionization. The presence of ultra-violet light, but most of all the high temperature of the cathode, favors the ejection of electrons from the interior of the cathode.

The anode on the other hand must be hot, otherwise it could not supply the positive ions which keep the cathode hot. If a third electrode were put in the arc acting as one of the anodes, then the discharge may be regarded as having two anodes. As one is sufficient to keep the cathode hot, the arc can pass to the other anode even although it is cold. A small portable lamp, with iron electrodes for thera-

---

<sup>1</sup>Am. der Physik No. 12; London Elect., Dec. 4, 1903; Electrical World and Engineer, January 2, 1904.



peutic work, is constructed on this principle, and is known as the Reiniger, Gebbert and Schall lamp.

The negative corpuscles, therefore, play an important part in the activity of the arc, acting (1) by carrying the arc discharge, (2) bombarding the anode to incandescence, (3) ionizing directly by collision, or indirectly by heating the anode, the gas or the vapor of the metal, of which the anode is formed, producing in this way (4) the positive ions, which serve to keep the cathode hot.

Metallic oxides project more electrons at high temperatures, and hence the arc, which requires a liberal supply of electrons is more easily formed of the oxide than of the pure metal.

The negative electrons, given off at different rates, evidently for different metals, influence the potential difference.<sup>1</sup>

Of the constants  $m$  and  $n$  in Fröhlich's formula, as measured by Fröhlich himself and Edlund, Lang,<sup>2</sup> Gross, and Shepard, Nebel, Arons,<sup>3</sup> Luggin for carbon electrodes in air at atmospheric pressure,  $m$  is about 39 volts, varying somewhat, however, with the size and purity of the carbons. It is diminished by soaking these in salt solution. The value of  $n$ , as given by different experimenters, varies considerably. This may and probably is due to their having used currents of different intensities, as Mrs. Aryton has shown that  $n$  depends upon the current, for as the current increases,  $n$  or the potential difference diminishes. When metallic, instead of carbon terminals are used the value of  $n$  or the potential difference depends upon the metal. As a rule this is greater the higher the temperature at which the metal volatilizes. The following table gives the value of the potential difference in volts for different substances:<sup>4</sup>

---

<sup>1</sup>Thomson, J. J. Conduction of Electricity through Gases.

<sup>2</sup>Lang: Wied. Am. XXXI., p. 384, 1887.

<sup>3</sup>Arons: Wied. Am., p. B, 1896.

<sup>4</sup>Thomson.

$$\begin{aligned} C &= 35, \text{ Pt} = 27.4, \text{ Fe} = 25, \text{ Ni} = 26.18, \\ \text{Cu} &= 23.86, \text{ Ag} = 15.23, \text{ Zn} = 19.86, \text{ Cd} = 10.28. \end{aligned}$$

Lecher<sup>1</sup> gives Pt = 28, Fe = 20, Ag = 8. Arons found that but 12.8 volts were required for Ag, but in this case the fall of potential along the arc itself was very small. With some of these metals used as terminals the arc is intermittent. Iron, platinum and mercury have been shown to give an intermittent arc, while no intermittence has been detected with carbon, silver and copper terminals.

These potential differences with arcs of different metals are mean values, and if the arc is intermittent they may differ greatly from the actual potentials during the passage of the arc. When the different metals are used for the two terminals, the potential difference may depend upon the direction of the currents. This is especially true when one of the terminals is carbon and the other metal, carbon and iron for example, or an iron-cored carbon. The arc passes much more readily when the carbon is the negative terminal, and the metal the positive one than it does in the opposite direction. So true is this that if such a pair of terminals were connected up with an alternating potential difference, the arc may only pass in the direction in which the carbon is the negative terminal, the potential difference being insufficient to drive it the opposite way. Some metals again are non-arcing metals; that is, they have a tendency to go out, such as brass, bismuth and cadmium. A great deal depends upon the size and shape of the electrodes, as well as the material of which they are made. Conditions which promote a rapid flow of heat from the extremities are favorable to the extinction of the arc.

The potential difference depends also upon the pressure of the gas through which the arc passes. Duncan, Rowland and Todd have shown that for short arcs the potential difference increases continuously with the pressure, while for longer arcs there is a critical pressure at which the potential

---

<sup>1</sup>Lecher: Wied. Am. XXXIII., p. 609, 1888.

difference is a minimum; this critical pressure increases with the length of the arc. The arc is affected by the nature of the gas; in hydrogen, for example, it is difficult to get a good arc, and this is supposed to be due in part to the more rapid convection of the heat from the terminals.

The potential difference required to produce an arc by the use of different metals, both in air and pure nitrogen, has been measured by Arons.<sup>1</sup> In the case of silver, while giving a good arc in air, none could be obtained in pure nitrogen. This Arons attributed to the absence of any chemical combination between the silver and the nitrogen. With the other metals used, zinc, cadmium, copper, iron, platinum, aluminum, lead, and magnesium, he obtained evidence of the formation of nitrites. Copper excepted, the potential differences in nitrogen are smaller than in air, the difference being very noticeable in the cases of iron and aluminum. In both these instances *more active ionization* of the air, due to their temperature of volatilization, rates of oscillation and electrons given off, the noticeable difference of potential between these two in air and nitrogen (smaller in nitrogen than in air) is to be accounted for. This is not yet clearly established.

Arons was only able to obtain arcs in hydrogen by using large currents and having the gas at low pressure. Cadmium, zinc and magnesium gave the best arcs in hydrogen.

As the metal or the carbon terminal of an arc volatilizes, the *arc* goes through a mixture of the vapor of the metal and the air, or in the experiments referred to, nitrogen or hydrogen, in which the terminals are immersed. This renders it difficult to interpret the effect of changes of pressure in the gas around the terminals, as the pressure of the vapor of the volatilizing metal is not known.

It has long been known that air in the vicinity of red hot metals is a conductor of electricity, nearly two centuries in fact.

---

<sup>1</sup>Arons, *Drudes' Annalen*, I., p. 700, 1900. Quoted from Thomson's *Conduction of Electricity through Gases*.

In 1853 Becquerel<sup>1</sup> showed that air at a white heat permitted the passage of electricity even when the potential difference was only a few volts. This result was confirmed by Blondlot<sup>2</sup> whose observations went still further, for he proved that air at a bright red heat was unable to insulate under a difference of potential as low as 1/1000 of a volt and that conduction through the hot gas was not in accordance with Ohm's law.

Attention was first called by Guthrie<sup>3</sup> to a very characteristic feature of ionization by incandescent metals, viz., the want of symmetry between the effects of positive and negative electrification. He showed that a red hot iron ball in air could retain a charge of negative, but not of positive electrification, while a white hot ball could not retain a charge of either positive or negative electrification.

The Electric Arc a Disinfectant.—An electric arc in operation serves as a powerful disinfectant.

The action of the energy of the electric arc spectra upon bacteria has been very fully considered, but it would seem that there is an effect produced more immediately than would follow upon the destructive action of the short and high frequencies so active chemically upon bacterial growths.

Experiments were made many years since with the Jablochhoff candles in the Paris sewers for the purpose of purifying them. The results were very satisfactory.

In 1881 Mr. Harold P. Brown, E. E.,<sup>4</sup> of New York, while using Brush arc lamps for lighting the basement of a store in Chicago, noted that within an hour after turning on the current, the odor from the *toilets* which was at first very offensive became entirely neutralized.

On an excessively hot day the author made the following observation; the refuse barrels which had accumulated

<sup>1</sup>Becquerel: *Annales de Chime et de Physique*, III., 39, p. 355, 1853.

<sup>2</sup>Blondlot: *Comptes Rendus*, XCII., p. 870, 1881; CIV., p. 283, 1887.

<sup>3</sup>Guthrie: *Phil. Mag.* IV., 446, p. 257, 1873. Quoted by J. J. Thomson.

<sup>4</sup>Personal communication.

in the basement of the apartment house occupied as an office over Sunday, prior to their removal Monday morning emitted a very unpleasant odor, which ascended and permeated the office rooms occupied by the electric-arc cabinet as well as rooms to the rear of it. The current operating the electric arc was turned on and in half an hour the author returned to the room, to find that every evidence of odor had disappeared and that the air was perfectly pure, so far as odor was concerned, while in the rooms more remote from the arc, the odor persisted as before. The action was at that time attributed to the ozone generated and unquestionably it is a factor. There is the nitrous oxide to be reckoned with as well, but the effect in all probability is due to an ionization of the air. Since then, if for any reason there has been the slightest odor in the offices the current has been turned on the arc lamp and always with the same result.

### The Mercury Vapor Lamp.

The temperature inside of the lamp, which depends upon the current, diameter and density of the vapor, is not ordinarily very high—a few hundred degrees Centigrade at the most.

The most striking feature of the lamp upon casual examination, is the color of the light which it emits. This, to be appreciated, must be seen as it is difficult of description. It is spoken of as having a yellowish-bluish green color, the nearest approach to naming the color. It suggests to the author an opalescent coloring. Spectroscopic examination shows the presence of two somewhat faint orange lines, two very bright green lines, two bright blue lines, and two faint violet lines. There are no red lines present and therefore it is impossible for the lamp to give off white light, as red is a necessary constituent of white light. From the orange, green, blue and violet present, results the characteristic coloring. Objects which ordinarily reflect red light, like the human being, for example, suffer a very remarkable and gruesome color distortion. The appearance is ghastly in the

extreme, but is overcome by the use of a specially prepared red or pinkish gauze which is thrown over the lamp as a scarf or drapery. This supplies the red frequencies and by reason of its preparatory chemical treatment functions as a radiant frequency transformer. A tube of red glass would permit no light to emerge whatever, for red glass transmits red light only and there is no red light to transmit. The light is extremely rich in ultra-violet waves, richer even than the arc light, but by reason of the glass of the vacuum tube there is no possibility of their emergence. It is very rich, however, in the visible chemical frequencies, and for this reason and also because of its diffusion, it is very valuable in photographic work. Its efficiency is estimated at from two to three times that of the arc light and from six to eight times that of the incandescent light. It consumes less current than the incandescent light.

It is impractical for applications where compression is desired to render a part anæmic. These lamps could be suspended around the walls of a large enclosing cabinet or room for general uses, but the author is not prepared to state that it would be well to use them in preference to the other sources of light if at all. They lack the radiance that renders sunlight, the electric arc, incandescent light even, so acceptable to the anæmic, neurasthenic or tubercular patient as well as of such therapeutic value. Rich as they are in ultra-violet light, it is of no value for less than 30 microcentimetres because of the glass enclosing tube. Objections have been raised because of the mercury vapor but the author fails to see how with this enclosed in a vacuum tube of glass it can possibly have any effect. Were it a quartz enclosing tube the ultra-violet would be powerfully in evidence and the result from exposure to so powerful a source of concentrated ultra-violet energy might be productive of untoward results. The author has had one of these lamps placed at her disposal during the past year but from observations thus far made, would not select it as a source of radiant light energy for therapeutic work. It can only be stated here as

an impression received from observations, not supported as yet by experimental data, that the absence of the red and the diminution in the orange and yellow, in other words, of those factors which give the sensation of radiance, is one for which its powerful chemical action cannot compensate.

There is in relation to physiological action and therapeutic uses of light a need for these long and slow frequencies—although in the present state of the biological action of light it is not known just what their mode of action is. Function they undoubtedly have. It only remains to be elucidated. Were the enclosing tube of such size and shape as to render it suitable for topical applications, the richness of the light chemically could be availed of.

The following data and the description of the test to determine its candle-power were furnished by Professor Sheldon of the Brooklyn Polytechnic Institute, in connection with the author's committee work on "Radiant Energy" for the American Electro-Therapeutic Association.

Data Concerning the Cooper-Hewitt Mercury Vapor Lamps.—An effort was made to determine the candle-power of this lamp by making use of an observer who was afflicted with color-blindness. His visual characteristics are shown by the following facts: He called a bright red glass green, and was very positive concerning it. He called a green glass brown or red and was not very certain. Blue he termed blue, amber was called a light red. A bright red was again called brown and he matched a bright red against a muddy purple as being alike.

The prominent lines of the mercury spectrum appeared to him as follows: The two orange lines as dark yellow, the faint green he could not see, the purple of long wave length he considered not as light as Columbia blue, but as blue, and the violet of shorter wave length he termed as the same color which could be purchased at a florist's. It will thus be seen that he is what may be termed red and green color blind. When used as a photo-metric observer in balancing two incandescent lamps against each other, both burning

at the same temperature, making use of a *Lummer Brodhun* screen he made settings which were practically identical with those of ordinary observers.

When balancing the light from an aperture  $10 \times 2$  centimetres placed in front of the vapor lamp against the standard 16 candle-power lamp he was unable to obtain a definite point of balance because of the different color qualities, but at a place where the corn yellow exhibits to the ordinary observer about the same depth as the sky blue, these colors changed suddenly to the eyes, the yellow appearing yellow, but the blue assuming a color he had never seen before.

By holding the green glass in front of his eyes he made very precise balance setting, which yielded the following results: Through the 20-centimetre-square opening passed luminous flux such as would come from 63.5 candle-power sources of 3.18 candle-power per square centimetre. The lamp was taking 3 ampères at 73 volts, exclusive of the starting rheostat.

Assuming a uniform distribution of light emanations, the tube which is 114 centimetres long, and of approximately 2.4 centimetres internal diameter, will give 870 candle-power.

It has been suggested that its value in medicine will be as a diagnostic agent chiefly.

As there are no red frequencies any red spot on the body of a person subjected to its action or any red object observed becomes a deep purple.

Therefore any mild inflammation or rash, either faint or more distinct, will become under its influence a distinct purple in appearance and an eruptive disease may be detected earlier and more clearly than would otherwise be possible.

The accompanying illustrations show the energy curve of different sources of light. The author is indebted to the courtesy of Professor Langley of the Smithsonian Institute for their use. (See Figs. 2 and 3.)

The second plate is introduced as showing the amount of energy wasted in sunlight, when considered as a luminous



Four Curves of Equal Areas, showing one unit of heat displayed successively in heat spectrum of Gas, Electric Arc, Sun and Fire-Fly.

ABSCISSAE. — WAVE LENGTHS.  
ORDINATES. — ENERGY AS HEAT.

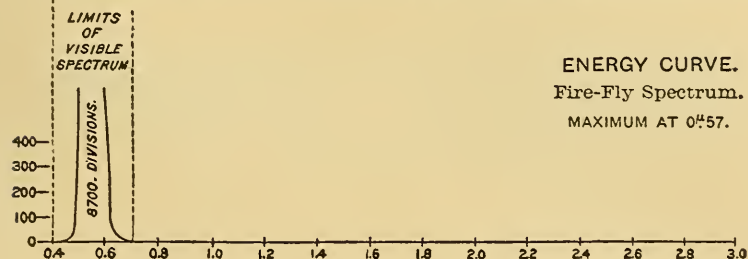
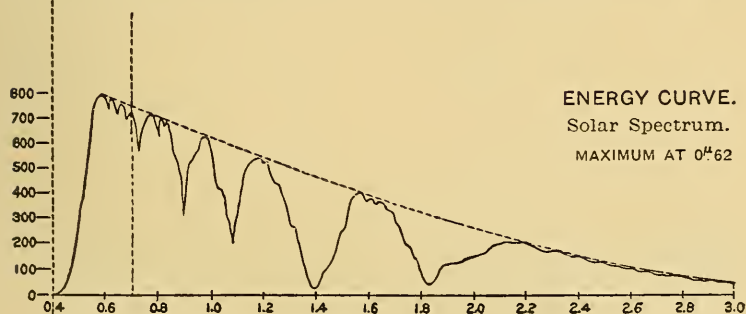
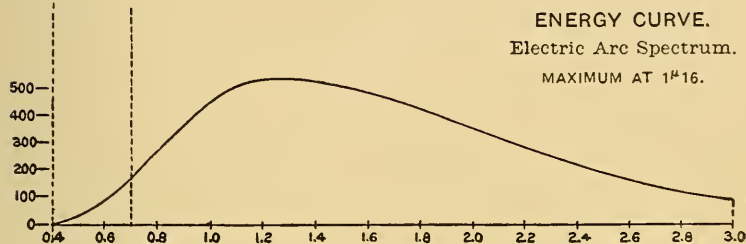

Fig. 2.



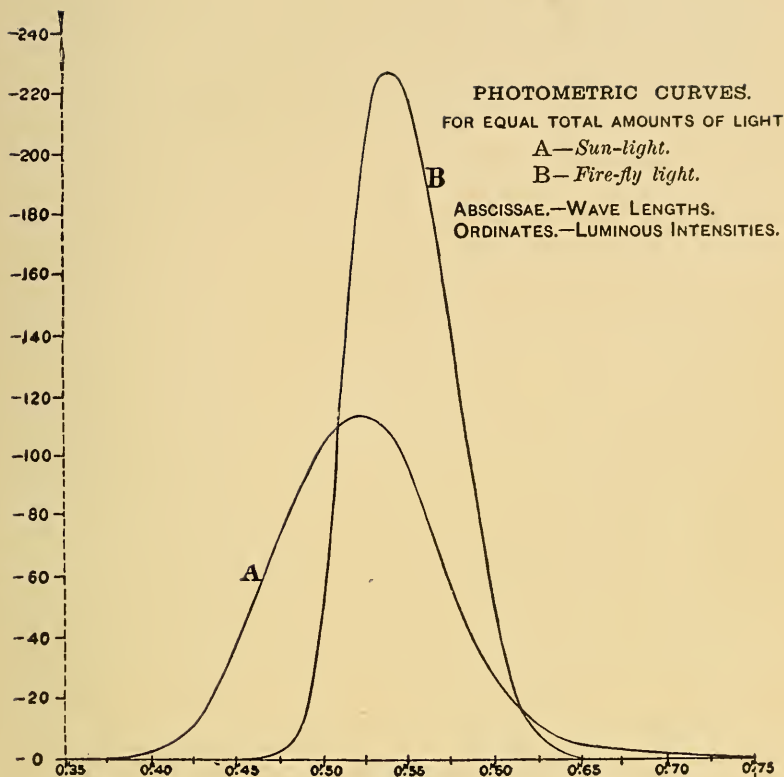

Fig. 3.



agent only, illustrating at the same time the luminous efficiency of the firefly spectrum. But as these pages endeavor to show, the sun shines not simply for the purpose of illuminating the darkness, but that life from the elementary forms to the higher organisms may exist.

## CHAPTER III.

### The Action of Light Energy upon Elementary Forms of Life.

The irritability of a mass of protoplasm of a protozoan of the simplest kind is established in a certain manner under the influence of light energy. This has been extensively studied.

Action of Luminous Rays upon a Plastide.—If a beam of parallel luminous rays of feeble intensity fall upon a plastide in water, the reactions between the plastide and the surrounding medium are favored by the energy delivered in this way. This was studied by Dantic.<sup>1</sup> Chemical reactions are established which are much more active on the surface upon which the light falls than on the opposite face, but feebly illuminated by the light filtered through the mass of protoplasm. The plastide is divided into two parts, so to speak, which are respectively the seat of excitations of different intensity. The result of this difference is shown by a direct action whose beginning and direction can be calculated by mathematical analysis, for a body of determined form.

Phototaxy Positive and Negative.—This theoretical fact is verified by a quantity of experimentation done by Strassburger, Verworn, Engelmann, etc., bearing upon *plastides*, diatoms, spores of algæ, bacteria.

---

<sup>1</sup>F. Le Dantic: *Materie Virante*, Paris. Mosson quoted by Leredde and Pautrier.

The movements vary in direction and the minute mass of protoplasm can be drawn out or retracted under the influence of a beam of light. In the first instance it is positively phototactic, and in the second negatively phototactic. On the other hand, there are certain plastides that are not influenced by light, that is, they are not phototactic. This latter condition may, however, be dependent upon the degree of light intensity to which it is subjected. If the intensity is too feeble it may appear to be non-phototactic when such is really not the case.

Leredde and Pautrier pertinently remarked that the intensity should always be given when positive or negative phototactic conditions are considered. For example, an amœba which will stretch out or contract its protoplasm under the influence of feeble light intensity will contract itself sharply if the intensity is increased.

In the absence of all phototactic phenomena it is difficult to establish whether or not the protoplasm under consideration did not react because the light was too feeble. However, all protoplasm can be considered as phototactic, either positively or negatively.

If an infusion containing various plastides be exposed to diffused light, certain among them will be seen to gather themselves into the brightest part, while others will remain in the shade.

It is in this way that Engelmann takes in a trap bacteria in a bright spot from a liquid kept in the dark. From a close study of this phenomenon it will be seen that it is not only the passage of light in obscurity which exercises an excito motor action upon protoplasm, but also difference of light intensity. Purple bacteria are particularly sensitive to this mode of action. If the intensity of the light illuminating the preparation be diminished, when examining them, the rotation of their bodies is reversed and they extend abruptly to a distance equal to ten or twelve times their length. Any spot thus illumined in a tube or receptacle containing the bacteria, becomes a veritable trap for them. They

readily enter the brightest spot which attracts them, but it is impossible for them to leave it, for in passing into the dark peripheric zone, they are sharply thrown back into the bright zone, just as iron filings are brought into relation with a magnet, for example.

In his experiments Engelmann illuminated the centre of the drop of water, upon which he was operating, then fixed and colored the mass of bacteria which had quickly assembled there. He obtained in this way what he calls a bacteriogramme. In this way he preserved the image of the space in which the bacteria were caught in a trap.

The excito motor action of light is very clearly shown on purple bacteria. They are one of the best examples, and are sensitive to the luminous excitant alone. Upon illumination they take on a state of continual motion or, as termed by Leredde and Pautrier, a period of photokinetic induction. When the light is removed they return to a state of complete repose.

Among the miscellaneous algæ positive phototaxy is equally frequent.

In his study of the movements of diatoms Engelmann<sup>1</sup> shows the cessation of movement when he placed them in the dark sheltered from oxygen and recovery of the same with light.

This phenomenon is complex, for it is not alone the presence of light, but it is also due to the consumption of oxygen, which they are unable to appropriate in darkness. In the light on the other hand the decomposition of the ambient CO<sub>2</sub> by their coloring matter furnished them at the same time with the assimilable C, the oxygen necessary to their movements.

It was observed in the closteria, a unicellular alga, of the group of *desmidia*, fringed at both extremities that when placed in a crystal receptacle upon which the beam of

---

<sup>1</sup>Pfluger's Arch. Vol. XXIX., 1879. Ueber Reizung contractilen protoplasmas durch plotzliche Beleuchtung und Engelmann. Ueber Licht und Farbenperception niederster organismen. Pfluger's Arch. Vol. XXIX.



light is directed, the alga is seen to lean itself upon the bottom of the receptacle by one of its extremities, and then place itself in such a position that its axis coincides with the direction of the incident light.

If the incidence of the rays of light be suddenly varied the alga pivots itself anew upon its extremity, which sustains it and goes again to place itself in the axis of the luminous ray.

At the end of a certain lapse of time, from 6 to 8 minutes, the alga executes a veritable "*pirouette*," and the extremity which served as the *point d'appui* becomes free and directs itself toward the source of light. This shows that there is then a true phenomenon of polarity and of alternate polarity. Pleurotenium and the *Micraserias Rota* also exhibit the phenomenon of constant or alternating polarity.

The zoöspores of the algæ are equally phototactic. They are drawn toward the luminous source by placing themselves in the direction of the incident ray, but turning always toward the latter, their non-ciliated extremity.<sup>1</sup>

With pluricellular algæ, the protoplasm in the interior of the cells exhibits a true phototaxy, as in the case of the *vaucheria*, where the grains of protoplasm charged with chlorophyll dispose themselves in two bands perpendicularly to the direction of the incident ray, or in the case of the *mesocarpus* in which each cell is terraced following its axis by a protoplasmic plate charged with chlorophyll which, under the influence of the light energy, turns itself so as to be perpendicular to the radiation.<sup>2</sup>

Myxomycetes, referred to under the action of light upon vegetable organisms, are either positively or negatively phototactic according to the degree of light energy. A light of feeble energy excites the stretching of their protoplasm

---

<sup>1</sup>Strasburger: *Wirkung des Lichtes und der Wärme auf Schwärmosporen*. Jena, 1878. Also, Stahl: *Ueber den Einfluss des Lichtes auf die Bewegungserscheinungen der Schwärmosporen*. *Verhand. der physic. medic. Gesellschaft, in Würzburg*, t. XI, 1878.

<sup>2</sup>Stahl: *Botanische Zeitung*, p. 297, 1880, quoted by Leredde and Pautrier.

and extends them; one of medium energy leaves them indifferent; but a light of intense energy causes them to run or to retract sharply with formation of granules in their interior.

The *Pelomyxa palustris* is an example of negative phototaxy. This curious observation was made by Engelmann.<sup>1</sup> The pelomyxa is a rhizopod and is analogous to the amœba which is found in the shade at the bottom of ponds concealed in the slime. Its protoplasmic body is rough, heavy and bare. It advances by putting forth flat pseudopods. Abandoned to itself, it progresses by movements of repetition, taking an elongated form and following a certain direction, but always the same. Upon exposure to light it contracts in a few seconds after the granule streaming has ceased and takes the form of a ball. If a weak light is maintained slow movements are again to be seen. When the darkness is dissipated by the gradual coming on of daylight there is no irritant action. Many myxomycetes comport themselves in an analogous fashion.

Flowers of tan flee from a bright light, which causes them to retract. Strasburger<sup>2</sup> picturesquely demonstrated the action of light on the plasmodia of *œthaliu*m; under the influence of a feeble light, he was able to call it to the surface of a tan ditch, and upon suddenly increasing the brilliancy of the light it was made to rebury itself in the ditch. In the light they develop short, compressed projections, with dark, long, thin, narrow processes.

Hofmeister,<sup>3</sup> in his studies upon the rôle of light in the relation to myxomycetes, observed that the *œthaliu*m septicum fled from the light, and always in the direction of the light rays. This is illustrative of the negative heliotropism of these bodies.

The *Pholada dactyle*, a marine mollusk observed by

---

<sup>1</sup>Engelmann: Ueber Reizung Contractilen Protoplasmas durch plötzliche Beleuchtung Pflüger's Arch. Vol XIX.

<sup>2</sup>Quoted by Leredde and Pautrier.

<sup>3</sup>Hofmeister: Die Lehre von der Pflanzenzelle.

Raphael Dubois, has been found to give evidences of phototactism in that part of the animal's body which is the seat of the dermatoptique vision. These phenomena seem to indicate that light in these instances acts in the same way as do artificial irritants.

Transformation of Form under the Influence of Light Energy.—The action of light energy upon these elementary forms of life is not confined, however, to excito motor phenomena, abundant as these are, as is evidenced by the contraction and extensions of protoplasm. The arrangement of the protoplasm of amoeboid cells, amoebæ, rhizopods, infusoria is markedly changed by exposure for any length of time to light or darkness as well. The action is then upon the form, producing modifications which are alike durable and definite. By its action the properties of protoplasm also may be completely modified and caused to assume new forms. These phenomena have been fully investigated by Brefeld<sup>1</sup> upon the Mucedines, also by Elving<sup>2</sup> and Laurent.<sup>3</sup>

Brefeld's work was carried out upon the Coprines, and he concluded that for the Basideo-Mycetes the development in light and darkness is very different. In darkness the development is bad, the head shortens, the foot is enormously elongated also.

The organs of fructification appear only in the light, in the darkness the mycelia are sterile.

Laurent's studies were upon two of the Hyphomycetes, the *Dematium pullulans* and the *Cladosporium herbarum*. He was able to derive the first from the second by sowing some spores of *Cladosporium* into must (moût) of beer and exposing them to the action of solar light energy. After some days of insulation these spores, transported into a new must of beer, developed growing forms of *Dematium*. They not only changed form but properties as well: the Clado-

---

<sup>1</sup>Brefeld: *Botanische Untersuchungen über Schimmelpilze*.

<sup>2</sup>Elving: *Studien über den Einwirkung des Lichtes auf die Pilsse*. Helsingfors, 1890.

<sup>3</sup>Laurent: *Annales de l'Institut Pasteur*, 1888.

sporium being exceedingly aërobie, while the Dematium can live in anaërobia.

By the sowing of some spores of *Aspergillus glaucus* in must of beer exposed to the action of solar energy, Elving obtained three kinds of yeast forms. These returned to darkness gave in their turn some new yeast forms, which were not developed after the type of *Aspergillus*, but after the type of *Penicillium*. This latter type was definitely fixed and was uniformly produced in subsequent generations.

Passage of Aërobie Life to Anaërobie Life under the Influence of Light Energy.—This phenomenon is observed in the purple bacteria as well as the motor phenomena described under the action of light. It will be recalled, movements are established upon their passage from darkness to light and upon their return to darkness, complete immobility. There is also a true modification of vital conditions, i.e., a passing alternately from the anaërobie state to the aërobie state and inversely.<sup>1</sup>

The Bacterium-Photo-metricum, studied by Engelmann<sup>2</sup> is the type of the best known of the purple bacteria. This micro-organism is exceedingly sensitive to the stimulus of light energy. So long as it is exposed to the light it propels itself swiftly about in the drop of water by the aid of the scourge-like thread which is found at the end of the bacterial body. Upon its return to darkness the movement of the thread gradually ceases and the bacterium remains motionless, to be stimulated again, however, to fresh movement under a renewal of the light energy.

It was observed upon examination in the drop, covered with a cover glass under the influence of a very feeble light, to approach the borders of the plate; while in a stronger light it remains collected in the centre of the preparation. In this latter instance it is very far from the oxygen. In the first instance the condition is the same in the diffuse

---

<sup>1</sup>Leredde and Pautrier.

<sup>2</sup>Archiv. f. d. ges. Physiologie, XIX., p. 1. and Handbuch der Physiologie, Vol. I., p. 370.

light as in the dark and there is need of a source of oxygen in order that it may live, hence it seeks the edge of the plate; in the second on the other hand, when exposed to the bright light, by means of its coloring matter, which is supposedly similar to chlorophyll, it is enabled to find the necessary oxygen in the decomposition of the ambient carbonic anhydride. .

Action of the Different Frequencies of Light Energy Upon Elementary Life.—Thus far the action of the total light energy has been studied but certain investigations have been made, showing that there is a difference in effect from the different frequencies of the spectrum. This is illustrated by the following interesting experiments of Verworn.<sup>1</sup>

Verworn examined with a microscope a ciliated infusorium, the *Pleuronema chrysalis*, which ordinarily is in a state of repose, that is immobile in water without ciliary movement. When under examination, if the diaphragm of the microscope be raised, the infusorium exposed to the action of light appears to leap impetuously, after a period of one to two seconds or latent period of excitation.

Verworn analyzed the influence of the different frequencies by interposing between the source of light and the plate of the microscope colored liquids, the transparency of which to the various frequencies had been determined by spectrum analysis.

He found that the maximum effect upon the leaping movements was obtained by the action of the blue and violet frequencies. To obtain the same effect where the thermal energy was utilized, it was necessary to have recourse to intense solar light, concentrating the energy by means of a concave mirror. Freund states that the same effect can be produced with intense heat rays.

The Action of Light upon the Ciliated Corpuscle.—Bergel has carefully studied the effects of light and darkness upon the movement of the ciliated corpuscle in the fol-

---

<sup>1</sup>Allgemeine Physiologie, Jena, 1895.

lowing manner: The microscope was placed upon an observation table within a dark cabinet. This cabinet was perfectly closed save for two openings. The one when illuminated was for the observer but when it was desired to shut off the light it was carefully darkened by curtains. Opposite the microscope was another opening which could at will either be closed or exposed to direct sunlight. Then by placing a ciliated corpuscle in motion under the microscope and darkening the window permitting the light to fall upon it, the motion of the corpuscle could be seen on inspection to grow slower and slower until it finally ceased. The more rapid and energetic the vibrational activity of the corpuscle before the window was darkened, the longer the period of activity of the corpuscle in the darkness, until it finally became motionless and *vice versa*; the slower and weaker the vibration of the cilia the shorter the time up to the cessation of all motion. But on the contrary, when a corpuscle which had kept in the dark and showed no motion whatever, was exposed to the bright daylight again the oscillation recommenced after a latent period, depending upon the duration of the exposure to darkness. The longer the corpuscle remained in the dark after it had become motionless the longer it continued in a quiescent state before resuming its oscillations. When the corpuscle was kept too long in the dark it showed every evidence of fatigue. This fatigue was also noticed when the experiment was repeated several times.

These experiments indicate not only a direct action on the ciliated epithelium of the respiratory tract and the necessity for light energy in respiratory pathologies, but illustrate as well the physical effect of the oscillating swing of light vibrations on atomic motion. At least this is the writer's interpretation of these very interesting experiments, nor do the phenomena produced admit of any other in the light of physical laws.

It is stated by Freund that, according to Uskoff, the ciliary movement of the epithelium of the œsophagus is equally swift in red and in violet light, but that it is sus-

pended if red light is substituted for previously acting violet light. Even among the ciliary infusoria, isolated specimens are found whose movements are stimulated by light.

Strassburger and Miguel have demonstrated that the phototaxic sensibility of the algæ, of their zoöspores, of the protoplasm of the *Vaucheria* or of the *Mesocarpus* is not brought into action by all the frequencies of the spectrum. The active frequencies are the blue, indigo and violet. The red and infra-red have absolutely no action.

The phototactic movements of the plasmodia of *Myxomycetes* are also under the influence of the most refrangible frequencies and are unaffected by the other frequencies of the spectrum. The bacterium *Photo-metricum* of the purple bacteria group is an exception. Engelmann<sup>1</sup> found upon examination of a drop of liquid containing a great quantity of these bacteria upon which a solar spectrum was projected that they accumulated with a particular predilection at certain points corresponding precisely with the absorption bands of the bacterio-purpurine, that is in the infra-red and in the orange and yellow. These therefore were the frequencies necessary to excite movement in the bacillus *photo-metricum*.

Thus far it has been shown that the movements of these bacteria are possible only if the oxygen necessary to them is furnished by the decomposition of the ambient  $\text{CO}_2$  through the intermediary of the coloring matter which impregnates them.

It will be seen as with plants that the frequencies most useful to them are those which correspond to the absorption bands of chlorophyll. The conclusion is therefore permitted that the bacterio-purpurine plays for the purple bacteria a rôle analogous to that played by chlorophyll for plants and the predilection of these bacteria for the red frequencies are explained by a functional adaptation.

---

<sup>1</sup>Bacterium Photometricum. Ein Beitrag zur vergleichenden. Physiologie des Licht und Farbensinns, Pflüger's Archiv., Vol. XXX.

Leredde and Pautrier in reaching this conclusion, regret that the studies and experiments of Laurent and Elving upon the change of form and of function under the influence of light were made only under the influence of the total light energy and that they did not see fit to analyze the action under the influence of the different frequencies.

Summary.—From a careful review of these very interesting observations of Engelmann, Laurent, Strasburger, Uskoff, Brefeld, etc., it is clearly evidenced that it is the blue, indigo and violet frequencies which are the effective ones.

By the action of light, and especially of the more refrangible frequencies, a series of phenomena are produced at the level of the protoplasm:

(1) An excito-motor action, i.e., the extension of the various movements of protoplasm.

(2) An influence on the growth and reproduction of the mycelium of the algæ.

(3) An extension of forms in one species lasting modifications faithfully reproduced by successive generations.

(4) The concurrent establishment of a complete overturning of the conditions of existence to the point of permitting an exclusively aërobic organism to become anaërobic.

In a study of the general physiology of the elementary forms of life, concludes Leredde and Pautrier,<sup>1</sup> the influence of light assumes an important place. The excito motor phenomena are the best known and studied. To produce them the action of the indigo, violet and ultra-violet frequencies are required.

---

<sup>1</sup>Photobiologie and Photothérapie, Leredde and Pautrier.



## CHAPTER IV.

### The Action of Light Energy upon Vegetable Organisms.

The necessity of plant life for light is greater than that of any other living organism. This is axiomatic. Without light energy plants become colorless, of imperfect structure and growth. In the absence of light it is impossible for them to take from the air the carbonic acid, absolutely indispensable to their existence. Nor can they by means of the chlorophyll assimilate it to their needs, setting free oxygen in the process, and retaining the carbon in new combinations, such as sugar, gum, starch, cellulose and albumen.

A study of the action of light upon vegetable organisms is much less complicated than that upon animal organisms, by reason of the absence of the nervous system in the former.

It is assumed by most physiologists that there is a direct chemical effect from light energy on the chlorophyll. This effect is dependent not only upon the intensity but upon the quality of light. All the frequencies of the spectrum have been shown to possess the property of producing chemical effects, although it is the higher and more refrangible rays as indigo, violet and ultra-violet which are regarded as especially active. The chlorophyll function, that is the decomposition of carbonic acid, however, depends upon the longer and less refrangible frequencies of the spectrum, the red and yellow.

It is clearly established by the experiments of Siemens, Dehérain and Bailey that the intense chemical energy of the ultra-violet frequencies is badly borne by plant life. For each class of plants a certain intensity of light energy is necessary for the most perfect performance of its assimilative processes; others again require but little light energy. The latter are those plants which are found in shady nooks, water courses, in dim forest aisles and in the depths of the ocean, ferns, mosses and marine algæ, for example. Of the sun-loving plants, the sunflower is a notable example, turning his face always sunward.

Life of Plants in the Dark.—It has been proven by the experiments of Boussingault<sup>1</sup> that a plant destined to be green when kept in the dark consumes its reserves and loses weight; the life of a plant, coming out of the sea and kept in the dark, depends upon the amount, i.e., weight of nutritive matter contained in the sea.

Necessity of Light for the Development of Chlorophyll.—It has been established by Timiriazeff<sup>2</sup> that the characteristic pallor of plants kept in obscurity is due to the presence of protophylline or reduced chlorophyll. When they are transported to the light, they become green through the absorption of the light energy by the protophylline.

There is another pigment existing in leaves, alongside of the chlorophyll, red in color, the erythrophyll of Bourgarel or carotene of Arnaud,<sup>3</sup> whose rôle is very little known. The most vigorous leaves, which means those of the deepest green, furnish the largest proportion of carotene; it is observed that it tends to disappear as does the chlorophyll when kept in darkness.

Exceptions to the Necessity for Light in the Development of Chlorophyll.—Chlorophyll appears in some plants budding in obscurity contrary to the general law.

---

<sup>1</sup>Agronomie, V. 246.

<sup>2</sup>Comptes Rendus, Acad. des. Sc. t. CII., p. 686, 1886.

<sup>3</sup>Comptes Rendus, Acad. des Sc. C. 751, 1885; CII. 119, 1886; CIV. 1295, 1887; CIX. 991, 1889.

Flahault<sup>1</sup> has shown that the bulbs of crocus vernus planted in the dark gives sprouts whose extremities are green.

It has also been proved by Bouilhac<sup>2</sup> that the *Nostoc punctiforme*, develops a pale green tint in total darkness, if it finds at its disposition a hydrate of carbon, such as glucose.

Grass when turned down continues to grow in the soil and presents a feeble green tint. This was noted by Kraus, but is a matter of common observation.

A green alga has been found by a polar expedition at a depth of 2,000 metres in the Atlantic. Light penetrates into water but 200 metres, so that here is an organism taking on its green coloring.<sup>3</sup>

Flahault and Griffon<sup>4</sup> have by their experiments proved that the substance in the plants grown in darkness is really chlorophyll. Flahault examined an alcoholic solution spectroscopically while Griffon caused some cotyledons of *Pin-pignon* to assimilate which had developed in darkness. Exceptionally then it is seen that chlorophyll forms in the absence of light a phenomenon at this time unexplainable.

Chlorophyll Assimilation; the Rôle of Light Energy in this Function.—The action of light in relation to chlorophyll assimilation has been thoroughly investigated independently of the respiration of plants. Among the modern botanists whom have studied the subject especially are Bonnier and Mangin.<sup>5</sup> They have shown that the two phenomena, i.e., respiration and chlorophyll function are distinct in their mode of action. Respiration, that is the absorption of oxygen and the exhalation of carbonic dioxide, goes on equally in light and darkness. By anæsthetizing the plants under ob-

<sup>1</sup>Ann. Soc. Nat. Botan. 6th Série t. IX. p. 169.

<sup>2</sup>Comptes Rendus, Acad. d. Sc. May 3, 1898.

<sup>3</sup>Leredde and Pautrier.

<sup>4</sup>L'Assimilation Chlorophyllienne, Paris. Naud, 1901.

<sup>5</sup>Bonnier and Mangin, L'Action Chlorophyllienne Séparée de la Respiration. Compt. Rend. Acad. d. Sc., t. C., p. 1303, 1885 et Ann. Sc. Natur. 7th Série t. III., p. 5, 1886.

servation they have proved the independence of the two functions, and found that darkness does not influence respiration, but that absence of light suppresses the chlorophyll function.

Chlorophyll production and function are dependent upon the presence of light. But chlorophyll is not the only substance capable of fixing carbon under the influence of light. De Candolle<sup>1</sup> has showed that the red algæ can disengage oxygen in the light; while Engelmann<sup>2</sup> thinks that the different coloring matters of the algæ, phycocyanine, phycoerythrine, and bacterio-purpurine of certain algæ of the category of the *bactériacées*, are also instances of assimilation carried on and dependent upon the influence of light energy.

At the base of all plant physiology is then this essential primordial phenomenon, or the assimilative phenomenon *par excellence* of the plant, which consists of the decomposition of CO<sub>2</sub> of the ambient medium and assimilation of carbon.

This phenomenon is produced by the intermediary of a series of colored substances or chromophylls, of which chlorophyll is the most diffused.

This assimilation of carbon is an essential exothermic reaction; for its production, it is necessary that an external energy should be operative, and this energy is furnished in light. It is the absorption of light by the chloroleucites, or by the other colored substances analogous to chlorophyll, upon which the chlorophyll function depends.

Nature of Chlorophyll Assimilation.—It is an established fact that under the influence of light energy a plant provided only with water increases its weight of dry matter; it fixes, in other words, its assimilative carbon.

The author finds in this a counterpart of the action of light energy upon the blood. In the latter instance it is a fixation or storing of oxygen, so necessary to animal life.

This exothermic reaction of chlorophyll assimilation produced by light is believed<sup>3</sup> to be produced in the plant or-

---

<sup>1</sup>Physiologie Végétale, t. I., p. 119.

<sup>2</sup>Botanische Zeitung, 1883

<sup>3</sup>Berthelot.

ganism simultaneously with the decomposition of  $\text{CO}_2$ , from the compensatory reactions which furnish the necessary energy.

The Effective Frequencies of Light Energy in Chlorophyll Assimilation.—The decomposition of carbonic acid by chlorophyll is dependent upon the less refrangible rays, red and yellow. Plants and parts of plants grown in the dark have no chlorophyll; the chlorophyll pigment being found in the light. From absence of light they become pale yellow in color, a condition known as etiolation.

The experiments of Siemens, Bailey and Dehérain, to be referred to later on, showed that the electric arc gave a light needed for chlorophyll; but for that matter all artificial sources of light may take the place of sunlight so far as chlorophyll is concerned, for they all give out the yellow frequencies. It has been proven that sprouting plants will grow dark green in a light barely sufficient for the reading of large print. This shows that the quantity of light need not be large.

By the utilization of various colored solutions, as filters, the different frequencies were cut off at will in the experiments made to determine the part of the spectrum necessary to the production of chlorophyll. For this purpose Pélétier's bell jars were used.

The chemical theory of the action of light energy on chlorophyll is the most widely accepted one. To it is opposed that of Pringsheim.<sup>1</sup> The latter holds that the chlorophyll pigment by the absorption of blue, violet and ultra-violet frequencies, without being decomposed itself, acts as a kind of light screen, lessening the degree of respiration, that is, the oxidation connected with the elimination of  $\text{CO}_2$ , and increasing thereby proportionally the assimilative processes, especially as they pertain to the collection of carbon and the giving off of oxygen, within the plasma of the chlorophyll body.

---

<sup>1</sup>Jahrb., XII., 1879-1881, p. 288, Quoted by Goodale, Physiological Botany, Gray's Botanical Text-book. Vol. II.

The subject of the frequencies of light energy most favorable to chlorophyll development has been extensively investigated by Gardner, Draper, Daubeny and Guillemin. Guillemin used successively a spectrum obtained by 3 different prisms, (1) an ordinary prism, (2) a quartz prism, and (3) a rock-salt prism. In the first instance, all of the energy save the ultra-violet was allowed to pass, in the second the ultra-violet, while in the third the infra-red were permitted to pass.

Later experiments by Timiriazeff places the maximum energy in the red region between the lines B and C. In other words in that part of the spectrum absorbed by chlorophyll. Always wherever in nature it occurs there is a constant proportion between the energy absorbed and the work done.

Theory of Complementary Colors.—Engelmann has advanced the theory that it is always the frequencies complementary to the color of the plant whose action is the most pronounced. This is not confirmed by other physicists, and is especially denied by Pringsheim.

The Action of Chemical Frequencies.—For the chlorophyll function the energy of the chemical part of the spectrum is necessary. Bonnier and Mangin have found that this assimilation also takes place in the presence of ultra-violet energy. The amount of this assimilative energy has been measured by the CO<sub>2</sub> decomposed.

Experiments made upon the leaves of *Arachidium* and of maize give the following results:

LIGHT ENERGY.

	Blue. cc	Red. cc	Green. cc
<i>Arachidium</i> .....	0.054	0.041	0.027
Maize .....	2.440	1.602	0.823

There is then a correspondence between the amount of energy and the intensity of the green coloration; conditions which are realized to the greatest extent from the effect of the blue frequencies.

Just here the reader must be impressed with the similarity of effect upon the human organism. It is the blue frequencies of light energy even into the ultra-violet, which are absorbed by the blood, and there exists in the human being a distinct relation between the energy which he is capable of exerting and the intensity of the color of the red media.

Influence of Light Energy upon the Growth of Plants—Actinauxism.—Dufour<sup>1</sup> from his experiments found that other conditions being equal, the plant growing in the light is more voluminous and more robust than that which has lived in semi-obscurity. Its leaves are more rich in stomata, its cells better walled, its grains of chlorophyll a great deal larger and more abundant and its assimilative energy much greater. This retardative action of light known as actinauxism is profoundly beneficent to the plant. It is a matter of common observation that in the dark the stems of a plant elongate more than in the light. This increase in length is not due to the production of new cells but to an exaggerated increase of cells already formed. It is not a phenomenon of over activity but rather one of degeneration. In the presence of light energy the growth is retarded, which is to the benefit of the plant, for there is thus secured the solidity, the equal partition of the *chloroleucites*, which are absolutely essential to its life. Plants grown in darkness are so slender, so lacking in fiber, that they are unequal to the support of their branches.

Plants grown in the dark have very long internodes and leaf-stems but practically no leaf surface. Through the effect of light in the assimilation of carbonic acid the growth of green leaf surfaces is accentuated.

The Transformation of Light Energy into Electro-Motive Energy.—Light energy is transformed in the plant by the changes of matter, and Waller<sup>2</sup> proved that light de-

---

<sup>1</sup>Influence de la Lumière sur la Forme et la Structure des Feuilles. Ann. Sc. Nat. bot. 7th Série. t. V. p. 311. 1887.

<sup>2</sup>Compt. rend. de la Soc. de biol. 1900. LII., p. 1903.

velops an electro-motive energy in the assimilating leaf more by the bright red frequencies, especially those absorbed by the chlorophyll, than by the heat rays.

Biedermann's<sup>1</sup> researches show that certain plants, among them iris, nicotine, begonia and nasturtium, are more favorable than others to demonstrate the existence of electric currents. If one of them be placed in connection with a galvanometer by means of electrodes attached to leaves on different sides, and one side of the plant be exposed to sunlight while the other side is kept shaded, then within from 3 to 10 seconds after exposure to sunlight there will be a flow of electricity from the lighted to the shaded parts amounting to .005 to .02 volt. This continues for about 5 minutes, when the magnet begins to swing back and shows an opposite current of considerable magnitude. The manifestations are similar to those of tetanized nerves. The electric current of green leaves is least in diffused daylight, greater in refracted light and most in direct sunlight. It is still further affected by the temperature, 20°C. being the optimum for iris. The electric activity is destroyed by cooking the leaves nor are the electric manifestations found in plants that do not have green leaves. Biedermann concludes that this is proof that the generation of electro-motor force accompanies the decomposition of carbon dioxide of the air, the exhalation of oxygen, and the fixation of the carbon of the air.

Influence of Light Energy upon the Movements of Plants.—In the transformation of energy which takes place in plants there may be distinguished two great groups of movements, viz., the movement of growth and the movement of irritation.

Growth Movement.—Under the stimulus of light energy, plants present definite growth movements, which may be regarded as irritation phenomena. When certain parts of a growing plant with a definite periodicity move automati-

---

<sup>1</sup>Dr. W. Biedermann, *Ergebnisse der Physiologie*.



cally one or more times, the phenomenon is known as nutation. Of those periodic nutation movements made by the green leaves is that known as nyctitropic nutation. By this is understood the closing and the folding of leaves either upwards or downwards against the common stem, according to the kind. It is the movement characteristic of sleep or rest. In the daytime the leaves are spread open that the light may fall upon them vertically. The sleep movement prevents the plant from too great radiation at night. These movements are due to the blue and violet frequencies. Red has the same action as the absence of light.

The growth movement is not dependent upon light under all circumstances. It is not required for the process of germination, nor for the growth of the roots and many blossoms. It is necessary for the growth of many living parasites, both the endophytic, or those living in the body of plants, and endozoic, those living in the body of animals.

In general light retards the growth under the conditions enumerated and this is also true of organisms above ground. By reason of this fact, the varying rate of growth at different times of day is explained. This rate is not for a time influenced by artificial exclusion of light. It is in the morning that stems and leaves grow most actively and least in the evening.

The growth of plants is lessened by all the frequencies of the spectrum except the red and infra-red, as will be seen from the effects of the electric arc in the experiments to be detailed under that head. The most refrangible frequencies are the most injuriously active not only lessening the growth but destroying the organism in part.

Influence of Light Energy upon the Structure of Plants—Heliotropism.—By heliotropism is understood an unequal development of the two sides of a plant, according to its relation to the source of light energy.

It is a matter of common observation that certain plants when left in a room lighted from one side only, incline toward the source of light. It was demonstrated by von

Sachs<sup>1</sup> that in plants lighted from one side only radial structures, stems and roots, bend until their long axes are parallel to the rays of light, and that dorsiventral structures, leaves, for example, assume a position in which their surfaces are perpendicular to the light rays. To those plants or organs which turn toward the light von Sachs applied the term positively heliotropic, while those which turn from the light were termed negatively heliotropic. He formulated the three following laws, viz.: (1) The orientation of a plant toward or from the source of light is determined by the direction of the rays. (2) Orientation of plants is affected only by the more refrangible rays, blue and violet. (3) Light of constant intensity acts continuously as a source of stimulation.

Stems and leaf stalks are as a rule positively heliotropic, while roots and rhizomes are almost all negatively heliotropic. In the former instance they grow toward the light source in the direction of the light rays, but in the latter they turn away from the light source.

To the entire phenomena, however, the term heliotropism is applied. A still further modification of this heliotropic faculty is observed in the case of green leaves; they turn themselves at right angles to the direction of light and are said to show a transverse or dia-heliotropism. If plants be moved from their normal position, their heliotropic movements take on curved movements, according to their relation to the source of light. Heliotropism is governed by the degree of brightness of light. When the light is very bright, organs which are usually positively heliotropic may become negatively heliotropic. This is an instinctive effort at self-preservation, for too much light is inimical to the normal development of the plant as well as too little. The direction of the incident light governs the heliotropic curvature.

This phenomenon has been extensively studied by Wies-

---

<sup>1</sup>Vorlesungen über Pflanzen, Physiologie, Leipzig, 1887.

ner,<sup>1</sup> Guillemin<sup>2</sup> and von Sachs.<sup>3</sup> They have found that the action begins with the frequencies of the green region and goes on up even into the ultra-violet, extending even beyond some radiations which impress salts of silver. The yellow frequencies are neutral, but on the other side the action is the same, rising on the side of the red but very feebly.

Microscopically this heliotropism shows itself by intracellular displacements, by protoplasmic currents, by a true phototaxy of the grains of chlorophyll themselves which come and distribute themselves upon the irradiated surface.

This heliotropic action was very prettily shown in 1890 by George Romanes<sup>4</sup> in his demonstrations before the British Physiological Society of experiments which he had made with fresh tender mustard plants.

He sowed the seed in suitable small receptacles, and when it began to sprout placed them in a dark chamber. In this chamber electric sparks were produced by an induction coil at varying rates. Invariably the plants turned their tops in the direction of the sparks, even when these were produced so slowly as once a minute. It would seem as though every tiny plant were looking toward the source of light. The experiment is an interesting one. Whether the phenomenon produced was due to the presence of ultra-violet frequencies only, is conjectural. There is the electric action to be reckoned with and the ionization of the air produced by spark discharge.

The Helianthus is a very striking example of this heliotropic faculty. On a sunny day it orients its stem toward the east after the rising of the sun follows the sun even to the middle of the day, remains there immobile, until toward the end of the day it leans toward the west, resuming the vertical position during the night.

<sup>1</sup>Die heliotropischen Erscheinungen in Pflanzenreiche. Denkschriften der k. Akad. der Wissenschaft. zu Wien. t. XLIII. 1880.

<sup>2</sup>Ann. des Sc. Natur., 4th Série, t. VII. p. 161, 1857.

<sup>3</sup>Botanische Zeitung. 1865.

<sup>4</sup>Roswell Park. A Report upon the Physics and Therapeutic Value of Cathode and Ultra-violet Rays. The Medical News, May 30, 1903.

Locomotor Movements.—A study of plant life shows that many unprotected plasmic bodies, such as the swarm spore of many algæ, present the phenomena of independent movement by means of their waving cilia. This movement is governed in part by temperature, and in part by the action of the incident light. These locomotor movements may be regarded as one of the irritation phenomena produced in plants by the stimulus of light energy. Microscopic inhabitants of the ocean, ponds, and lakes, just as larger animals change their position by reason of the influence of light. Sunlight attracts them, and they often rise to the surface from the depth of the waters in which they live. The water changes in appearance, loses its transparency and takes on different colorings, dull green, bluish brown, or red when they are present in great numbers. Prominent among the algæ, which will actually move themselves upon exposure to light, is a whole series of the Desmidiæ, particularly the *Closterium moniliferum*.

Water plants, however, appear at the surface of the water, by reason of their production of oxygen, which lessens their specific gravity. Reproductive cells of the algæ, swarm spores, zoöspores, which are capable of independent movement, as are the infusoria, move as far as possible in a straight line toward the source of light. This is a heliotropic movement, but some such cells are repelled rather than attracted by light, and are, therefore, regarded as negatively heliotropic. Whether they turn on the longitudinal axis of their body or not, that is to right or left, again depends upon the light ray.

Heliotropism is dependent, as are so many of the phenomena of plant and animal life, upon the short and high frequencies of the blue region of the spectrum; while the frequencies of the red region, like darkness, do not affect their action at all. The creeping, or amæboid movements exhibited by the plasmodia of myxomycetes, as of "flowers of tan," are dependent upon the stimulus of light energy. These bodies move away from the bright spots into the

shade, working themselves slowly along on their base. They are, therefore, negatively heliotropic. The movements of chlorophyll bodies are possibly dependent on this plasma movement, and seems to bear a relation to the greater or lesser intensity of light.

Every lover of nature is familiar with the intense deep green of the leaves of phanerogams, mosses and the prothallia of ferns. This is due to the slow changes in the position of the chlorophyll corpuscles in the protoplasm. Under the influence of the stimulus of light energy, especially the shorter and higher frequencies, these chlorophyll corpuscles collect mainly in the cell surfaces turned toward the leaf. While in the dark they collect mainly along the side walls of the cell, at right angles to the cell surface. Whether this is a direct influence of light upon the protoplasm, or an indirect influence induced possibly by primary change in the chlorophyll corpuscles, is not certainly known. The position of the chlorophyll corpuscle varies during night and day. According to Stahl the position for the most part of flat chlorophyll corpuscles with regard to the incidence of light is divided into the "surface position" and the "profile position." The position of the chlorophyll corpuscle in all cases is governed by the following general rule: (1) When the stimulus of light energy is at a medium of brightness, the chlorophyll corpuscles turn so as to present the broadest surface possible. (2) When there is a maximum of light energy, i.e., direct sunlight, they turn their narrow edge to the light. (3) When there is a minimum of light energy, or darkness, the narrow edges are turned, as when the sun's direct rays fall upon them.

In the second instance they present the edge of the leaf that the light energy may not be absorbed and act destructively; while in the absence of light energy the change of position is that of rest or sleep. This movement is the property of the chlorophyll corpuscles or bodies in all assimilating tissues.

They also change in form according to the degree of

brightness. When the stimulus of the light energy is most favorable to their needs they assume the flattest position, that is, a position horizontal to the superficies of the leaf. In common with the pigment cells of animal organisms chlorophyll corpuscles are capable of contraction. This again is dependent upon the energy of the light stimulus. The green of a plant may take on a lighter or darker shade according to the degree of light energy. This characteristic of the chlorophyll corpuscles of plants finds its counterpart in the pigment cells of the chameleon. The protoplasmic current in plant cells, which frequently is only recognized under the microscope after mechanical stimulation, seems ordinarily to be independent of light, although it is proved to be governed by temperature and the presence of oxygen or contained water. The exclusion of light does not affect the protoplasmic current. It goes on just the same as far as is now known. External conditions, however, may be so changed that the protoplasmic current may after all be radically influenced by light. Experiments were made by E. Josing as follows:<sup>1</sup> (1) objects with freely flowing protoplasm were subjected to the effect of weak solutions of ether or chloroform, and (2) the constituent of the air necessary to their life, carbonic acid, was withdrawn by means of a suitable agent from the air. Under these conditions the protoplasmic current ceased to flow when the light was excluded, but resumed its course upon its readmission.

The injurious effects of electric arc light, which is, after all, but a miniature sun, were first noticed by Siemens in 1880, as is shown in subsequent pages.

Data as to the injurious effects of light on plants was first furnished by Pringsheim. There are no changes especially characteristic of these injurious effects. The following conditions have, however, been noted: rigidity, formation of nodes, concretions of plasma, granulations, especially in the cell nucleus, but without any especial char-

---

<sup>1</sup>Jahrb. d. Wissensch. Botanik, 1901, Vol. XXVI.

acteristic. There is no such intense nor disruptive effect produced by light energy, when acting injuriously, as by heat. A sudden change of temperature intensifies corporeal movements. On the other hand, a maximum light intensity tends directly toward precipitation in the plasma and toward its rigidity. Contraction occurs only upon death supervening, but vacuolization does not take place.

Influence of Light Energy upon the Blossom.—The color of flowers is influenced by the different frequencies. By using various colored lights, various shades of the lilac, for example, may be obtained. The influence upon the aroma under the red frequencies is very great. Strawberries thus grown have a very delicious aroma and crassula flowers, which are nearly scentless in ordinary sunlight, give out a delicate banana-like fragrance.

The absence of light retards the development of flowers, and their color is less intense in darkness than in sunlight. This diminution of intensity of coloring varies with the species, with some there is little change, but with others a complete loss of coloring. As a rule, flowers thus developed are smaller, but on the other hand the peduncles are sometimes more fully developed. They also are less in size and weight, including the supporting pedicles, save in those instances where the increase in the size of the peduncles counterbalances the diminution of the rest of the plant.

Plant life in common with animal organisms is subjected not only to the chemical effect of light, but the thermal or heat effect as well.

Following the introduction of electric light, the influence of the latter in relation to plant life was studied. The first experiments were made by Hervé Mangon in 1861.<sup>1</sup> By this experiment he showed that the electric light can cause the production of chlorophyll and also heliotropism, or the phenomena of bending or turning to the light.

In 1869 Prilieux<sup>2</sup> showed that the electric light, in com-

---

<sup>1</sup>Compte Rend. 53, 243.

<sup>2</sup>Compte Rend. 69, 410.

mon with other artificial lights, is capable of promoting assimilation, or the decomposition of carbon dioxide and water. General Pleasanton conceived the idea of growing vegetables and fruits in greenhouses constructed of blue and violet glass, and published his results in 1877. He reported the production of extremely fine fruit, and that the growth of figs was accelerated. These experiments were next followed by those of C. W. Siemens in England and P. P. Dehérain in France.<sup>1</sup> These were still further supplemented by the experiments at the Agricultural Station of Cornell University in 1891 and 1892,<sup>2</sup> the latter comprising the only definite investigation of the subject upon what might be considered a practical or horticultural scale. The English experiments, although eminently practical, were conducted by an electrician, the French were largely confined to physiological problems, while those of Cornell University were approached from the standpoint of the gardener.

In Siemens' experiments, the lamp in the first instance was placed inside the greenhouse and in the second suspended over it. That is, in the first series, all the frequencies of the spectrum of an electric arc from the lowest to the highest were in evidence. In the second series the ultra-violet of less than 30 microcentimetres were cut off. In both cases marked effects upon vegetation in a very short time were observed. His light source measured photometrically produced 1,400 candle-power. When the light was placed inside of the house and no absorbing media for the ultra-violet frequencies intervened plants within 3 or 4 feet of the arc suffered much, the leaves of melons and cucumbers which were directly opposite the light, turned up at their edges and looked as though they had been scorched. In general, however, all plants which were exposed to normal conditions during the day and to 6 hours

---

<sup>1</sup>Quoted in Bulletin 30, Agricultural Experimental Station, Cornell University, Aug., 1891.

<sup>2</sup>Bulletin 30 and 42.



of electric light at night, "far surpassed the others in darkness of green and vigorous appearance generally."<sup>1</sup>

The electric light fruits had an equally good flavor with the others. Supplementary experiments were made in the following winter 1880-1881, with a lamp of 4,000 candle-power inside a greenhouse of 23,118 cubic feet capacity. The light was in operation all night and at first it was used without a globe. This again meant the exposure of all the plants to the short and high frequencies or ultra-violet rays. "The results were anything but satisfactory." A clear glass globe was then placed upon the lamp, following which most satisfactory results were obtained. Peas, raspberries, strawberries, grapes, melons, and bananas fruited early and abundantly under continuous light; solar light by day and electric light by night. The strawberries are said to have been "of excellent flavor," and the grapes of "stronger flavor than usual." Competent judges pronounced the bananas of "unsurpassed flavor," and the melons "remarkable for size and aromatic flavor." Wheat, barley and oats grew so rapidly that they fell to the ground of their own weight. The effect of interposing a mere sheet of thin glass between the plants and the source of electric light was most marked. On placing such a sheet of clear glass so as to intercept the rays of the electric light from a portion only of a plant—for instance, a tomato plant—the effect was most distinctly shown upon the leaves. The portion of the plant under the direct influence of the naked electric light, though a distance from it of 9 to 10 feet, was shrivelled, whereas, that portion under cover of the clear glass continued to show a healthy appearance, and this line of demarcation was distinctly visible on individual leaves; not only the leaves, but the young stems of the plants soon showed signs of destruction, when exposed to the naked electric light, and these

---

<sup>1</sup>Proceedings of the Royal Society, XXXI, 210 and 293. Rep. British A. A. S. 1881, 474.

Abstracted in Nature, XXI, 456, March 11, 1880. Editorially treated in the same issue.

destructive influences were perceptible, though in a less marked degree, at a distance of 20 feet from the source of the light.<sup>1</sup> Here the significance of the intense chemical activity of the ultra-violet frequencies cannot fail to be appreciated.

In the other series of experiments Siemens placed an electric lamp of 1,400 candle-power about 7 feet above a sunken melon pit which was covered with glass. The arc was protected by a clear glass globe. In these experiments the light energy was filtered through the media of 2 thicknesses of glass, effectually absorbing all the ultra-violet frequencies. Seeds and plants of mustard, carrots, turnips, beans, cucumbers and melons were placed therein. The arc was in operation 6 hours each night, and the plants had sunlight during the day. In all cases those plants "exposed to both sources of light, showed a decided superiority in vigor over all the others, and the green of the leaf was of a dark rich hue." Heliotropism was observed in the young mustard plants. Electric light appeared to be about half as effective as daylight. The condensed moisture in the roofs of the greenhouses at night obstructed the passage of the light. At one time the light was suspended over two parallel pits nearly 4 feet apart, and the effect was observed upon plants under the glass and in the uncovered space. In all cases the growth of the plants was hastened. Flowering was hastened in melons and other plants under the glass. Strawberries which were just setting fruit were put in one of the pits and part of them were kept dark at night, while the others were exposed to light. The most of the berries had attained to ripeness and presented a rich coloring after 14 days, the light having burned 12 nights, while the fruits on those plants exposed to daylight only had hardly begun to show a sign of redness.

Siemens also noted that the presence of the electric arc light enabled plants in the greenhouses to bear a higher

---

<sup>1</sup>Siemens' Report.

temperature than they otherwise could. While Siemens' observations and conclusions were applied by him to a practical "electro-horticulture," as he termed it, yet they have a value from the physiological side as well.

The following conclusions were reached by Siemens as a result of his observations :

(1) Electric light is efficacious in producing chlorophyll in the leaves of plants and producing growth.

(2) An electric centre of light equal to 1,400 candle-power, 2 metres from growing plants, appeared to be equal in effect to average daylight in March. More economical effects are to be obtained by more powerful light centres.

(3) That the carbonic acid and nitrogenous compounds generated in diminutive quantities in the electric arc exercise no sensible deleterious effects upon plants enclosed in the same space.

(4) That plants do not appear to require a period of rest in the 24 hours, but make increased and vigorous progress if subjected during the daytime to sunlight and during the night to electric light.

(5) That the radiation of heat from powerful electric arcs can be made available to counteract the effect of night frosts, and is likely to promote the setting and ripening of fruit in the open air.

(6) That while under the influence of electric light, plants can sustain increased stove heat, without collapsing, a circumstance favorable to forcing by electric light.

Dehérain's experiments were conducted at the Exposition d'Electricité in Paris in 1889. A small conservatory standing inside the exposition building was divided into two compartments. One compartment was darkened and the glass painted white upon the inside; this received the electric light and all solar light was excluded. The other compartment was not changed. A lamp of 2,000 candle-power was used. In such an exposition building sufficient sunlight is not received to maintain a healthy growth. The unprotected arc was used first and run continuously. Barley in head and

flax in flower, also chrysanthemums, roses, pelargoniums and a variety of ornamental plants were brought into this compartment. Most of them were seriously injured after seven days of continuous lighting. All the pelargoniums lost their leaves, cannas discolored, four-o'-clocks were tarnished and bamboos were blackened. "But the most curious effect was produced upon the lilacs; all the parts of the leaves that had received the direct rays from the lamp were blackened, while those protected by the upper leaves preserved their beautiful green color, and the impression produced upon the epidermis by the electric rays had the clearness of a photographic plate." Azaleas, deutzias and chrysanthemums were similarly affected. It was found that the discoloration did not extend beyond the first layer of the palisade cells. Those plants subjected to solar light by day and the electric arc by night were injured in the same manner, but not to the same degree. Old leaves suffered most. The pelargoniums sent out mere shoots, and the young leaves resisted the action of the light much longer than the mature ones. The flax continued to grow and the barley ripened. Plants exposed to the electric light alone were able to assimilate, but the action was very slow. One hour of sunlight was equal to several days of electric light in assimilation. In two weeks the condition of the plants was so bad that the arc was thereafter protected by means of a glass globe. The experiments then proceeded in the same manner. Sprouting seeds grew alone in electric light for a time, then drooped and died, not being able to make true leaves. Sprouting maize turned black, but maize in full growth remained in good condition for two months, though not growing any more. While new leaves appeared on roses and other plants, they grew slowly or not at all. In previously formed fruits, seeds did not ripen, nor flowers appear, save in the case of barley, which made good seeds. Many plants remained stationary, and assimilation for all was much more feeble than with the unprotected arc.

Dehérain, in discussing the physiology of the plant under

experiment, came to the following conclusion: (1) The electric light from arc lamps contains rays harmful to vegetation. (2) The greatest part of the injurious rays are modified by glass. (3) The electric arc contains enough rays to maintain full-grown plants two and one-half months. (4) The light is too weak to enable sprouting seeds to prosper or to bring adult plants to maturity.<sup>1</sup>

The experiments at Cornell conducted by Bailey extended over a year, and were made more from the gardener's point of view than those of Siemens and Dehérain. They are of equal interest with those detailed, but as they were made under conditions favorable to the growth and development of vegetation, and for the purpose of showing the value of the energy of the electric arc in forcing establishments, they are not so striking in their injurious effects.

In the experiments of Siemens and Dehérain, the action of the great quantity of the higher and more refrangible frequencies, the blue violet and ultra-violet present, produced in a very marked manner their characteristic effects.

Conclusions from the Cornell University Experiments 1889-1890:

(1) That electric light may be used under such conditions as to make it fairly comparable to sunlight in its power to promote protoplasmic activity.

(2) The electric light acts as a tonic to plants so that they are able to endure adverse conditions which otherwise would cause them to collapse.

(3) That the electric light is a true vital stimulus, since the effect of its use at night upon plants is essentially the same as that of the longer day of the arctics upon plants growing in that region.

*Nature*<sup>2</sup> in commenting editorially upon Siemens' experiments and the relation of light to vegetation, said: "But the scientific interest of its present application must rest

<sup>1</sup>Am. Agronom. VII. 551 (1881). Quoted by Bailey, Agricultural Bulletin 30, Cornell University, Aug., 1891.

<sup>2</sup>Nature, March 11, 1880.

mainly on the fact that the cycle of the transformation of energy engaged in plant life is now complete, and that, starting from the energy stored up in vegetable fuel, we can run through the changes from heat to electricity, and thence to light, which we now know, we can store up in vegetable fuel again." To-day these experiments as well as those of Dehérain, Bailey and Cornell University serve to still further emphasize the value of light energy from artificial sources for the purpose of treating disease. The author's interest in the subject of light energy was originally greatly stimulated by the result of these experiments.

Conclusion.—From all this mass of experimental data, the paramount importance of light energy upon the vegetable organism is evident. Vegetable life is not possible save in the presence of light. Chlorophyll assimilation, the fundamental phenomenon of plant life, is only possible in the presence of the energy of light. The frequencies of the spectrum influencing this function are the red, orange and the violet. Nor is the rôle of light confined to this phenomenon of vegetable cellular life alone. It plays another most important part in the life of the plant. In connection with geotropism, it rules the direction of the growth of the stem; the leaves, their position, the position of the flowers, in short, it determines some actual movements of the three parts of the plant. In the production of all these phenomena the chemical part of the spectrum is alone active.

## CHAPTER V.

### The Action of Light Energy upon Bacteria.

Introduction.—In a study of the bactericidal power of light one cannot fail to detect great discrepancies at the hands of different experimenters. These are due to the conditions of experiment. In no instance, at least but seldom, and with solar energy not at all, is the light intensity measured. To be exact, the hour of the day, the nature of the place of experiment, the condition of the sky, clear or obstructed, the light intensity, the temperature and the influence of the culture medium are all factors in the results, and similarity of result will only follow when each and every experimenter takes into consideration all of these factors. For practical work, it is sufficient to speak of the bactericidal power of the light, but not for laboratory experiment.

The influence of these different factors is considered first, with the results obtained by the various experimenters taking them into account. In the subsequent pages the bactericidal power of light is discussed in its more practical relation, rather than in its laboratory relation.

Transformation of Bacterial Species under the Influence of Light Energy.—Aside from the phototactic phenomena presented by bacteria there is also the phenomena of transformation of one species into another under the influence

of light energy, as was described in the case of the *Hypomyces* by Elfving<sup>1</sup> and Laurent.<sup>2</sup>

Laurent experimented with the bacillus discovered by Breunig in the waters of the city of Kiel. Light plays a considerable rôle in the development of the coloring matter of chromogenic bacteria, and on the other hand, according to the intensity, acts to suppress the chromogenic function. He found the Kiel bacillus cultivated upon a potato, to show at the end of 24 hours a purple color. From exposing to the light a series of cultures for a varying time, Laurent established that at the end of 3 hours the bacillus was decolorized and modified to the forming of a new race, decolorized and stable. D'Arsonval and Charrin reached analogous conclusions from their experiments with pyocyanic bacilli.

The Influence of Temperature.—It has been observed by Duclaux<sup>3</sup> apropos of the *Aspergillus Niger* and of the *Bacillus Ramosus* that in the neighborhood of the critical temperature a difference of a half to a degree between the two cultures can produce profound differences between them.

Influence of the Culture Medium.—This has been carefully considered by Duclaux. The bactericidal action of light is markedly influenced by the nature of the culture medium.

That experiments may have their full value a precise method should be followed: a well-defined microbic species selected, an appropriate culture medium employed, and the time of exposure to the light energy exactly measured.

Duclaux's experiments were made upon the spores of a bacillus of milk, the *Tyrothrix Scaber*, and upon a coccus found in the boil of Biskra (*Biskra-Button*—see Chapter XII.), probably identical with the streptococcus pyogenes, and from them he reached the following conclusions:

(1) The degree of resistance to the sun of the spores

<sup>1</sup>Studien über die Einwirkung des Lichtes auf die Pilze. Helsingfors, 1890.

<sup>2</sup>Annales de l'Inst. Pasteur, 1888. C. R. Soc. Royale Bot. de Belgique t. XXVIII, 1889.

<sup>3</sup>Traite de Microbiologie, t. I. Paris, 1898.



of various bacilli is variable with the genus of bacillus, and for the same bacillus, with the nature of the liquid in which it has been cultivated.

(2) It is hardly more than at the end of a month of exposure that these spores, preserved dry in a balloon of glass, begin to become incapable of developing themselves in an appropriate medium.

(3) The cocci, of which the spores are unknown, are more rapidly killed than the spores of the bacilli.

(4) These cocci are less resistant insolated in the dry state than when they are contained in a culture liquid.

(5) The death of all microbes is as much more rapid as the insolation is stronger, and a great deal more prompt even under a feeble sun than in the dark or in diffuse light.

The minimum duration of resistance was in those experiments of 12 hours of insolation in July; the maximum duration of 2 months, for some spores of bacilli insolated dry.

At the same time Arloing<sup>1</sup> made analogous experiments upon a well-defined species, the bacillus anthrax, and made parallel observations upon variations of virulence and variations of vitality produced by light.

By these experiments he proved that gaslight sufficed to retard the evolution of enseeded spores, while sunlight transformed the cultures into a series of "vaccines" gradually attenuated. Arloing found that the spores were killed at the end of 2 hours of exposure in the month of July with a temperature of 35°C.; while it was necessary to have 30 hours of exposure to render sterile the mycelium of the same bacillus in full development. The spores show themselves less resistant to the action of light than the bacilli themselves.

Roux<sup>2</sup> also made a study of the action of light energy upon the anthrax bacillus. He found that the vitality of the spores exposed to sunlight were preserved to the 29th hour at the minimum, while the maximum time was the 54th hour.

<sup>1</sup>C. R., 1885, t. C., p. 378, t. CI., p. 501.

<sup>2</sup>Annales de l'Institut Pasteur, 1887, t. I., p. 445.

After 83 hours of insolation there were some insolated spores, sheltered from the air that gave some beautiful cultures. This is again illustrative of the fact that the microbicidal action of light is dependent upon the presence of oxygen.

As a result of many experiments Roux concluded that, after 3 or 4 hours of exposure, the insolated medium has undergone the chemical changes which renders it unfit for the development of the spores which are not yet killed and will be only by the 30th or 40th hour. The modifications brought about in the medium which are so profound as to prevent the generation of the spores are not, however, sufficient to prevent the evolution of bacilli already formed, which are better able to withstand the light energy. If bouillon which has been insolated and will no longer permit charbon spores to germinate, be sown with bacterium filamentosum, it will multiply there in abundance. Whatever modifications the nutritive medium exposed to the action of light produce, the presence of oxygen is necessary.

Upon exposing charbon spores to the action of the light, Roux found that those contained in open glass tubes with free access to the air became sterile; while those placed in closed tubes would germinate in the same bouillon after insolation, if the containing mass were transferred into an aërated tube.

The Rôle of Accessory Conditions in the Bactericidal Action of Light.—The influences which govern the bactericidal action of light energy are (1) the medium, (2) the atmospheric condition, whether humid or dry, and (3) the influence of the air itself.

A study of the influence of these conditions serves to elucidate the subject still further.

Momont's<sup>1</sup> experiments demonstrated the influence of the medium. He exposed to the sunlight some pieces of blotting paper soaked with charbon blood, and at the same

---

<sup>1</sup>Annales de l'Institut Pasteur, t. VI., 1892.

time some of the same blood upon sterilized plates. By inoculation he proved that the charbon bacterium was killed on the sterilized plates in  $6\frac{1}{2}$  hours of insolation; while the pieces of blotting paper still gave some virulent cultures after 16 hours. In the latter instance, the charbon bacteria were protected by the fibers of the paper.

Momont has also experimented to determine the influence of the atmospheric states of humidity and dryness, but the point is not yet elucidated.

The experiments of Pansini, made at Naples, consisted in exposing tubes containing some sowings made upon gelatin or gelose. These tubes were closed with cotton wool and exposed to the solar energy. A tube was taken each half hour, and placed in the incubator to observe its development.

Pansini concluded that the action of light at first simply retarded the growth, and subsequently proved destructive. The time required for a lethal effect upon the bacterial growths varied with the microbic species.

He has made a very precise series of experiments which show the relation of the bactericidal action of light energy to the time element. Exposure to the sun was made of some pendant drop cultures of anthrax bacillus. The temperature varied between  $32^{\circ}$  and  $40^{\circ}$ . He drew from one every 10 minutes to count the germs by the method of plaques.

The second day's examination is as follows :

Plate exposed 10 minutes to sun.....	360 colonies
“ “ 20 “ “ “ .....	130 “
“ “ 30 “ “ “ .....	4 “
“ “ 40 “ “ “ .....	3 “
“ “ 50 “ “ “ .....	4 “
“ “ 60 “ “ “ .....	5 “
“ “ 1 hour 10 minutes.....	0
“ “ to the same temperature in the dark.....	2520 “

The spores of the bacteria insolated dry were much more resistant, and gave a table of the following order :

Plate exposed 30 minutes to the light.....	360 colonies.
“ “ 1 hour “ “ “ .....	208 “
“ “ 2 hours “ “ “ .....	48 “
“ “ 3 “ “ “ “ .....	30 “
“ “ 4 “ “ “ “ .....	34 “
“ “ 5 “ “ “ “ .....	8 “
“ “ 6 “ “ “ “ .....	3 “
“ “ 7 “ “ “ “ .....	3 “
“ “ 8 hours and more .....	0 “
Plate exposed in the dark.....	1015 “

By these tables it will be seen that a much more rapid destruction took place in the first moments of exposure, only, however, to become complete at the end of more than an hour for the bacteria, and of more than 8 hours for the spores.

The Action of Insolated Frequencies of Light Energy upon Bacteria.—D'Arsonval and Charrin,<sup>1</sup> studying the causes of exaltation, or of attenuation of the microbe and the media which they inhabit, analyzed, amongst others, the effects of light upon the bacillus pyocyanicum. Submitting this bacillus to the action of the white light, he found first a diminution of its chromogenic power. He then exposed the “sown” tubes, for a time varying between 3 and 6 hours, one in the chemical part, the others in the calorific part of the spectrum, all the other conditions being equal. Next a drop of each of these cultures was placed upon agar. After 2 days in the incubator at 35 degrees, only the culture submitted to the red light gave pigment, the other remaining colorless. By increasing the time of exposure of the tubes to the light, those that received the violet light remained sterile while the others gave prosperous culture. These authors take care to note the excessive variety of the effects obtained according to the intensity of the luminous sources.

Ledoux-Lebard<sup>2</sup> studied the action of the luminous agent upon the diphtheria bacillus. He proved that the action of diffuse light did not prevent the development of cultures of

<sup>1</sup>Comptes rendus Acad. des Sc., janv., 1894.

<sup>2</sup>Archiv. de Med. Exper. et d'Anat. pathol., 1893.

bacteria, while the solar light sterilized the bouillons of culture in a few days; that diffuse light killed the dry cultures of diphtheria, spread in thin layers, in 24 hours of illumination, and had a bactericidal power for bacilli in dilution in distilled water. He confirmed also the observation that the bacillus of diphtheria, like other microbic species, is killed by the most refrangible rays of the spectrum, the less refrangible rays having no bactericidal action.

The action of both sunlight and that of the electric arc upon the growth, and the life of various kinds of microorganisms, is then firmly established by extensive and very carefully conducted experiments, and that this action without the living tissue takes place can in no sense be gainsaid. That it takes place in living tissue by the action of the chemical rays which penetrate them, is disproved by the experiments of Bernard and Morgan.

This bactericidal action of light was first pointed out by Downes and Blunt,<sup>1</sup> who in 1877 communicated a paper to the Royal Society on the "Influence of Light upon Proto-plasm." They called attention to the fact, that diffused and still more direct sunlight had the power of killing putrefaction bacteria, that heat rays play no part in this action, and that the most active are the blue, violet and ultra-violet frequencies, but that the red and orange are not entirely inactive. Their experiments still further show that it did not matter whether the bacteria were damp or thoroughly dried, but that the presence of oxygen was of absolute necessity for this bactericidal effect. They were of the opinion that the action of light in these experiments upon bacteria was not to be sought in a modification of the nutritive basis, and also considered the possibility that the products of metabolism in the bacteria may be influenced by light. These facts were at first disputed by Tyndall, but they soon had abundant confirmation from all sides. The experiments of Downes and Blunt were made with any bacterial mixture of

---

<sup>1</sup>Proceedings of the Royal Society of London, Dec. 6, 1877, Vol. XXVI., p. 488, and Dec. 19, 1878, Vol. XX., p. 109.

decomposing liquids conveniently at hand, but later investigators have used pure cultures.

In 1892 Marshall Ward<sup>1</sup> presented a paper to the Royal Society of London, entitled "Experiments on the Action of Light on the Bacillus Anthracis." He showed the effect of light on bacilli from the Thames, and found that in all cases solar and electric-arc spectra exerted no perceptible action whatever in the infra-red, red, orange or yellow region, while all the bacteria were injured or destroyed by the rays from the blue or violet spectrum. The intervention of a thin piece of glass resulted in cutting off a large proportion of the effective rays. The most distinctive rays, i.e., those at the end of the blue and beginning of the violet, were to some extent effective, even after reflection from the inner face of a quartz plate covering the film, and the glass on which it was supported. Ward also showed that moulds and yeast cells were injured in their development and growth, a fact more recently corroborated by Bie. This former investigator goes on to say that these results evidently suggest that the naked arc light may prove to be a very efficient disinfecting agent for use in hospital wards, railway carriages and other places where the rays could be projected directly on the organisms. In this report Professor Ward stated:

"The results are as startling as they are important, for if the explanation given of the phenomena observed in the following experiments turns out to be the correct one, we stand face to face with the fact that by far the most potent factor in the purification of air and rivers of bacteria is sunlight."

Professor Ward in connection with Sir Oliver Lodge<sup>2</sup> exposed culture plates to the ultra-violet energy of the electric arc alone, as well as to the energy of other parts

---

<sup>1</sup>Quoted from Committee Report on Light as a Diagnostic and Therapeutic Measure by Margaret A. Cleaves, M.D., to American Electro-Therapeutic Association, Sept. 25, 26, and 27, 1894.

<sup>2</sup>Lectures to Medical Practitioners upon Physics, by Sir Oliver W. Lodge. Archives Roentgen Ray, June, 1904.

of the spectrum, establishing a much more powerful bactericidal action with the ultra-violet alone.

In the more recent investigations, care has been taken to consider not only the fact of the bactericidal action of light, but also the physical factors in that action. To that end the sources of light were taken into account, their intensity and the use of light filters as well. These physical factors were most carefully considered in the experiments of Bernard and Morgan to be subsequently detailed.

Theodore Geisler<sup>1</sup> in 1892 found no qualitative difference between sunlight and electric light, only a quantitative difference. In the course of some experiments on the typhoid bacillus he found that the most decided effect was produced by the rays from the violet end of the spectrum.

His experiments were conducted in the following manner: two cultures were sown with typhus bacilli and placed in the dark, two in the sunlight, and two placed 1 mm. from an electric arc of 1,000 candle-power.

He concluded as follows: That there is no qualitative difference between the electric arc and solar light, and that all the frequencies of the solar and the electric arc spectrum, save the red, retard the development of the typhus bacillus, and that this influence is so much the stronger the more refrangible are these frequencies, i.e., the shorter and higher their wave length.

The author has substantiated this action of the chemical frequencies, visible and invisible, as obtained from a 7-ampère water-cooled iron electrode lamp, a 5-minute application destroying them completely. The same was true of the staphylococcus pyogenes aureus.

P. A. Khmelevsky,<sup>2</sup> of St. Petersburg, after prolonged experiments, concluded that both solar and electric light have an undoubted inhibitory influence on the growth of microbes.

---

<sup>1</sup>Centralblatt für Bakteriologie, V. II., 1892.

<sup>2</sup>Quoted by author in 1894.

Klebs-Löffler<sup>1</sup> discovered that diffused light does not prevent the development of cultures of diphtheria at ordinary temperatures, or at a temperature as high as 95°F., but that sunlight arrests development, and after an exposure of several days sterilizes bouillon. This bactericidal power of light toward the bacillus of diphtheria is due almost exclusively to the rays of greatest refraction, those at the other end of the spectrum having little or no action of this kind.

There is a very extensive bibliography upon this subject, and Freund<sup>2</sup> refers to the following experimenters: Faligati (1), Arloing (2), Duclaux (3), Lubbert (4), Janowski (5), Santori (6), Raspe (7), Geissler (8), Kolliar (9), Dandrien (10), Chmiliewsky (11), Gaillard (12), Marshall Ward (13), Ledoux-Lebard (14), Pansini (15), d'Arsonval and Charrin (16), Roux (17), Billings and Peckham (18), Kruse (19), Koch (20), Beck and Schultz (21), Dieudonne (22), Buchner (23), v. Esmarch (24), Giunti (25), Martinaud (26), Momont (27), Wittlin (28), Richardson (29), Shickhardt (30), and Ruhemann (31). This bibliography is appended for the benefit of the reader who may not have access to Freund's book.

---

<sup>1</sup>Quoted by the author in 1894. Com. Report on Light as a Diagnostic and Therapeutic Measure Am. Electro-Therapeutic Ass., 1894.

<sup>2</sup>Freund, Radiotherapy, Rebman & Co.



## BIBLIOGRAPHY.

- (1) *Compt. rend.*, 1879, Vol. LXXXIX., p. 959.
- (2) *Ibid.*, Vol. C., p. 378, and Vol. CI., p. 511.
- (3) *Ibid.*, 1885.
- (4) *Ref. in Raum*, *Zeitschr. f. Hyg.*, Vol. VI.
- (5) *Centralbl. f. Bakteriologie*, Vol. VIII., p. 167.
- (6) *Boll. della Accad. med. d'igiene*, Roma, Vol. XVI., p. 386.
- (7) *Einfluss des Sonnenlichtes auf Mikroben*. Dissertation, Schwerin, 1891.
- (8) *Centralbl. f. Bakt.*, Vol. XI., p. 161.
- (9) *Ibid.*, Vol. XII., p. 836.
- (10) *Annales d'Hygiène*, 1888, p. 448.
- (11) *Wratsch*, 1892, No. 20.
- (12) *Thèse de Lyon*, p. 396.
- (13) *Proceedings of the Royal Soc. of London*, Vol. LII., p. 393, and Vol. LIII., p. 23.
- (14) *Arch. de medec. exp., etc.*, Ser. 1, Vol. V., p. 779
- (15) *Riv. d'igiene*, 1889.
- (16) *Arch. de physiologie norm. et patholog.*, Vol. VI p. 335.
- (17) *Ann. de l'institut. Pasteur*, 1887.
- (18) *Centralbl. f. Bakt.*, Vol. XIX., p. 244.
- (19) *Zeitschr. f. Hygiene*, 1895, 322.
- (20) *Ueber bakteriologische Forschung*, Berlin (Hirschwald), 1890.
- (21) *Zeitschr. f. Hygiene*, Vol. XXIII.
- (22) *Arbeiten aus dem Kaiserl. Gesundheitsamte*, Vol. IX.
- (23) *Centralbl. f. Bakt.*, Vol. XI., p. 781, Vol. XII., p. 217, and *Arch. f. Hygiene*, Vol. XVII.
- (24) *Zeitschr. f. Hygiene*, Vol. XVI.
- (25) *Stat. sper. agrar. ital.*, Vol. XVIII.
- (26) *Compt. rend. Acad. d. Sc.*, Vol. CXIII.
- (27) *Annales de l'institut. Pasteur*, 1892.
- (28) *Wiener klin. Wochenschr.*, 1896.
- (29) *Transact. of the Chem. Soc.*, 1893.
- (30) *Friedreich's Blätter f. gericht. Med.* 1893, p. 405.
- (31) *Zeitschr. f. diät. und phys. Therapie*, Vol. IV.

Among the lower forms of life, especially upon bacteria, strong light has a fatal action.

The bactericidal action of light belongs to the ultra-violet end of the spectrum.

By means of an ordinary arc lamp bacteria may be killed in from 5 to 8 hours, but by means of concentrated arc light through condensing lenses of quartz, they can be killed in as many minutes (Finsen).

Both solar and the electric light, when diffused, are much less active than when concentrated, and require much longer to exert their bactericidal and disinfecting action. This action is very mild with an incandescent light as compared with the electric arc and the sun, nor is it to be regarded as a germicidal agent, although it is by no means inert, as it has abundant blue and violet frequencies, which are chemically active. Blue light of great intensity has been shown by Kaiser to have a bactericidal action. See Chapter XIV.

Below the ultra-violet then, the spectrum is not active as a direct bactericidal agent, but there is a modifying influence exerted by the chemical frequencies (blue and violet) tending to a diminution of the virulence and ultimate death of pathogenic organisms.

Dieudonne observed that direct sunlight will kill bacteria in one-half hour, diffused daylight in 6 hours, an electric arc light of 900 nominal candle-power in 8 hours, and an electric incandescent lamp in 11 hours.<sup>1</sup> The action of sunlight upon bacteria depends upon the season of the year, as its intensity naturally varies. The experiments of Finsen, Bang and Strebel show that concentrated sunlight checked the growth of bacteria after one minute, and caused death in 5 to 7 minutes. Concentrated arc light checked the growth after 4 to 5 minutes and killed the bacteria in from 15 to 20. Arc lights with metal electrodes and the electric spark kill micro-organisms after a few seconds, 5 to 40.

---

<sup>1</sup>Dieudonne, quoted by Freund.

The disinfectant action of light has been clearly demonstrated after the rays have penetrated clear water to a depth of at least 30 centimetres. This shows that water exposed to the sun's rays, for example, if perfectly clear and not of great depth, can be freed from pathogenic organisms. But as it has been shown by Bernard and Morgan in their experiments, that 2.5 centimetres of water is sufficient to cut off four-fifths of the rays from the middle of the ultra-violet region, in which are the active bactericidal frequencies, it follows that this disinfectant action of solar light to exposed water to a depth of 30 centimetres must be due to a penetration of the visible chemical frequencies, blue and violet.

The bactericidal effects of sunlight have been extensively studied. The evidence shows that sunlight plays an important part in nature in the disinfection or self-cleansing of rivers.<sup>1</sup> The water of rivers contaminated by sewage is found to become free from bacteria after having flowed for some distance. That a part of this demonstrated effect may be due to dilution, to deposit of sediment, and to absorption or decomposition of substances by plants or animals is very probable. Still the disinfection of running water is undoubtedly contributed to very largely by the chemical frequencies of sunlight. It also has an effect upon the dust of streets. This was the subject of experiment by Wittlin,<sup>2</sup> who showed that it was disinfected in a high degree by sunlight. The bactericidal effect of direct sunlight upon germ-containing clothes, bedclothes, etc., was tested by von Esmarch, who found that the action is confined to the exterior layers of the objects, and does not penetrate into the interior at all.

Tubercle bacilli are quickly killed by direct exposure to the solar rays, the time varying according to circumstances, from a few minutes to several hours; while the diffuse rays

---

<sup>1</sup>Prausnitz: *Influence des Egouts de Munich sur l'Isar*. Munich, 1889.

<sup>2</sup>Quoted by Freund, *Radiotherapy*.

will destroy these organisms in from 5 to 7 days, their virulence diminishing before their death. (Koch.)

The bactericidal effect of light is dependent on the quantity of light. It appears to have been proven by Krebs<sup>1</sup> that an arc lamp using 5 ampères of current as in an ordinary electric-light bath, has practically no power over the micro-organisms of the skin. In the case of arcs taking from 60 to 75 ampères, Freund<sup>2</sup> found that no bactericidal action took place when the rays were passed through living tissue. The ear of a black rabbit was stretched between the rays and a plate culture of staphylococcus pyogenus aureus. The culture was placed in the incubator after an hour's exposure, but the next day was found to be covered with colonies of bacteria. The same negative result followed the experiment with the ear of a white rabbit, and also with the ear moistened with adrenalin. In all 3 cases the inflammation of the ear developed in 24 hours.

By a sufficiently prolonged exposure to the active solar rays practically all pathogenic bacteria and spores may be destroyed. "The germicidal action seems to be due partially to changes in the medium involving its contained oxygen, but chiefly to a direct action of the chemical frequencies of light."<sup>3</sup>

Different kinds of bacteria are differently affected, some being much more quickly affected than others. The experiments of Larsen<sup>4</sup> showed that the bacilli of typhus, diphtheria, plague and splenic fever have very little resisting power, while tubercle bacilli and staphylococci offer greater resistance. Light is favorable to the growth of some forms. This was observed by Engelmann in bacterium photometricum, by Gaillard in yeast and mould fungi, and by Schenk<sup>5</sup> in a coccus cultivated from the feces.

---

<sup>1</sup>Zeitschrift für Diät. und Physikalische Ther.

<sup>2</sup>Freund, Radiotherapy.

<sup>3</sup>The General Principles of Preventive Medicine. Prize Essay, W. Wayne Babcock.

<sup>4</sup>Mittheilungen aus Finsen's Med. Lichtinstitut, I., p. 89.

<sup>5</sup>Larsen, Engelmann, Gaillard, Schenk, quoted by Freund,

The spores and the bacilli of splenic fever offer different powers of resistance also, as shown by Arloing, who succeeded in killing the former in 2 hours' exposure to direct sun heat, while from 26—30 hours were needed for the latter.

A degree of illumination used may be insufficient for the complete checking of the development, yet may in some cases prove harmful to the formation of pigment. But in the case of other bacteria again, i.e., *micrococcus ochroleucus*, light is a necessary condition for this.<sup>1</sup> All of the experimental work shows that by the exposure to light the development of the bacteria is not only checked, but also the virulence of the micro-organisms is lessened.

For the purpose of proving in what part of the spectrum the bactericidal frequencies are to be found, science is most indebted to Vlademar Bie, Sophus Bang, Bernard and Morgan. The two former are known in connection with Finsen, being associated with him in his work.

Bie's experiments were made with the bacillus prodigiosus and the light from a 35 ampère arc at 44 to 46 volts, giving about 600 candle-power. The light was concentrated by a Finsen apparatus, and fell vertically upon the culture. Vessels with plano-parallel glass walls enclosing a layer of fluid 3 cm. in thickness were used as light filters. As absorbing media Bie used (1) a fresh 1% sulphuric acid solution of quinin with a few drops of sulphuric acid, which allows the passage of all the rays but the ultra-violet; (2) a 5% solution of chromate of potassium, letting through red to green inclusive; (3) a 1½% solution of bichromate of potassium, letting through red to green inclusive; (4) a 1½% solution of bichromate of potassium, letting through red to yellow inclusive; (5) a 1-7% solution of fuchsin, letting through red alone.

The light intensity was determined by comparing the degree of blackening of spots, produced by exposure of aristo paper to the light during definite periods of time.

---

<sup>1</sup>Freund.

Bie found as a result of these experiments that all the frequencies of the visible spectrum, and the invisible chemical frequencies or ultra-violet (the infra-red were not examined), in an increasing ratio from red onward, checked bacterial development. The action was found to increase with the ratio of refrangibility, but was especially marked in the blue, violet and ultra-violet frequencies. It was only after prolonged illumination that a bactericidal action was obtained from the red, orange and green frequencies. It was not until an exposure of  $1\frac{1}{2}$  hours had been made with light that even the faintest perceptible retardation of growth was observed from the action of pure red light.

The experiments of Sophus Bang were conducted with the greatest care. He took into account all the conditions to be noted with regard to light-action, the strength of light used, the distance of the object from the ray source, the kind of rays passing the filters and the amount passing through, the percentage of light penetrating through the bacteria (taking into account the absorption and refraction of the light through the containing vessel and the culture medium).

Everything was so arranged in making these experiments that the beam of light should meet with as few obstacles as possible on its way from the light source to the object. The reflecting planes were as few and as simple, and the absorption and refraction as slight as possible; an even temperature was maintained, and measures were adopted for varying the strength of the light according to the gradation desired. In his experiments Bang used an apparatus in which the bacteria culture was spread out for examination in the thinnest possible layer, e.g., as a suspended drop on thin quartz plate. This quartz plate was used as the lid of a "moist chamber," which, in turn, was fixed in a box filled with water of an even temperature, kept constantly flowing by a paddle wheel. The light was then admitted through a quartz window in the side of the box, and its intensity and direction of incidence exactly estimated. Under these conditions Bang reached the conclusion

that under the influence of light at a distance of 28 cm. from a 35-ampère 50-volt electric arc, at an angle of  $45^\circ$  to the axis of the carbon, after a part of the heat rays had been kept back by a layer of water 25 mm. in thickness between quartz plates, and at a temperature of  $30^\circ\text{C}$ ., a 3-hours prodigious broth culture in a pendant drop is sterilized in about one minute, a 10 to 15 hours culture in from 3 to 5 minutes. The light acts more quickly at  $45^\circ\text{C}$ . than at  $30^\circ\text{C}$ ., sterilizing a 3 hours culture in about half a minute.

The older the culture, therefore, the more resistant it is to the action of the light, and further with increase of temperature the bactericidal action from light increases.<sup>1</sup>

More recently two English physicists, Bernard and Morgan, at the suggestion of Dr. Allen Macfayden have conducted a series of very careful experiments to determine (1) to what portion of the ultra-violet spectrum is the bactericidal action due, and (2) is it a primary or a secondary effect due to the reaction established in the tissues.

This well-known action of the higher and shorter frequencies of light vibrations, or light without heat, to destroy micro-organisms without the body, is axiomatic. This point was first covered by the experiments and verified at every turn. That organisms inside of the living body were destructively acted upon by light vibrations was regarded as a matter of considerable doubt. Just here it may be well to note in passing that the bactericidal action attributed to radio-active substances, to the X ray, to high-frequency currents or to other forms of electricity, unless in the polar action of the continuous current, anodal, by reason of its intense acidity and free oxygen, cannot in any instance be regarded as an immediate lethal effect upon the micro-organisms within the tissues, but rather as an inhibitory action, while the reaction established in the tissues through the local or general expenditure of one or the other forms of energy,

---

<sup>1</sup>For detailed description of Bie's and Bang's experiments the author is indebted to the English translation of Freund's Radiotherapy, pp. 406, 407, 408.

renders them an unfit habitation for living micro-organisms. It becomes simply a question of the survival of the fittest. And more, there is an action upon the oxygenating power of the blood-stream which tends to a removal of the detritus loading the vascular system, and at the same time the products of cell necrosis. That there is an effect upon the products of bacterial metabolism as suggested by Downes and Blunt seems very certain, tending to their removal, an effect of more importance even than the actual destruction of the bacilli.

By their experiments Bernard and Morgan<sup>1</sup> found that light was powerless to destroy bacteria in those cases where its rays were made to pass through any organic substance before impinging upon the bacteria, and even the thinnest film of agar served to protect the bacterial cultures. Much less can the bactericidal rays penetrate living or dead tissue under the ordinary conditions of experiment. This statement they proved in the following manner:

The light from an automatic arc lamp, that is, a lamp in which the carbons were kept at a suitable distance by means of a clock-work arrangement, was allowed to pass through a metal cylinder through which water constantly circulated to eliminate heat, and which was closed at each end with a disc of quartz. An agar plate was thickly inoculated with an active culture of *bacillus coli communis*, and exposed to the light directly after inoculation, and then incubated for 24 hours or longer at 37°C. The light was only permitted to fall on a portion of the plate in order that the organisms should grow naturally on the other part, and thus serve as a control. A current of 7 ampères was used at a distance of 10 cm. from the arc.

In 11 seconds the comparative number of surface colonies was greatly reduced, but those in the depths were unaffected. After an exposure of 2 hours and under the same conditions, the deep colonies were still unaffected.

---

\* The Physical Factors in Phototherapy. By J. E. Bernard and H. D. R. Morgan. *British Medical Journal*, Nov. 14, 1903.



Again a portion of the human skin, in one instance the cortical layer, in another the subcutaneous cellular tissue, was stretched over the quartz disc of the apparatus covering it entirely. An active culture of bacillus coli communis was then placed by means of a sterilized brush, upon an agar plate; this in turn was placed so that the light from the arc fell directly upon it after passing through the cooling chamber and the human skin. After a 2 hours exposure no effect was produced on the bacilli, as on incubating the plate at  $37^{\circ}\text{C}$ . for 24 hours, the resulting growth was found to be equally vigorous over the entire surface of the plate.

The experiment was repeated both with a living and with a dead frog's foot, and with equally negative results. The light passing at the side of the frog's foot produced a destruction of almost all the surface bacilli, while those protected by the semi-transparent webbing of the foot grew normally. (See Fig. 4.) The reason why all the colonies on the surface of the agar are not destroyed even where the undisturbed light falls upon them is still undetermined. It is perhaps possible that some few of the organisms during the process of inoculation have been introduced under the surface, and not being strictly superficial, are protected by an overlying absorbent film of agar.

From these experiments they were led to the conclusion that the bactericidal rays being non-penetrative, the therapeutic effect of light might possibly be due to the reaction produced in the tissues by the light rather than by the direct bactericidal action of the rays themselves.

A series of experiments were then made to differentiate, if possible, between the frequencies which are bactericidal and the frequencies of vibration which excite a reaction in living tissue. In this at the time of their report they had only been partially successful.

In order to discover the most active bactericidal rays, a continuous-current hand-fed arc was used, and the spectrum, as transmitted by a spectroscope with quartz lenses and

prisms, was allowed to fall on superficially inoculated plates. A subsidiary quartz lens of 18-inch focus was used to project the image of the arc on the slit of the spectroscop, thus obtaining the spectrum of carbon in the same manner as for photography, the superficially inoculated bacterial plate being used instead of a photographic plate.

It was found that the bactericidal effect was entirely confined to the ultra-violet portion, as shown in Fig. 5. The line shown at *V* is where the ultimate edge of the visible violet fell, the red in the spectrum falling at the extreme edge of the plate. The bactericidal lines are seen to begin at 2.5 cm. from the edge of the visible violet, and to extend from that point for 1.8 cm. into the ultra-violet. The photograph of the plate showed that the ultra-violet extended 1.5 cm. beyond this. No effect whatever was obtained with any other portion of the spectrum after 2 hours' exposure, and with the slit of the spectroscop open to an extent that would have been regarded as inadmissible in photography. The active bactericidal radiations have thus been accurately determined and lie in that portion of the spectrum between  $\lambda =$  (wave lengths) 3,287 and 2,265, or in about the middle third of the ultra-violet region as seen in a photograph of the spectrum of carbon. Neither the extreme ultra-violet nor those nearest to the visible violet region appeared to be active. The affected portion of the bactericidal plates corresponded to a photograph taken of this portion of the spectrum, and it was possible to identify the nearly sterile lines on the plate with those known to exist in the ultra-violet spectrum of carbon.

The conclusion is, therefore, reached that relatively the action of the other portions of the spectrum is negligible with the activity of this portion, although when using white light it is possible that there is a slight action extending over the whole spectrum. This conclusion affords, then, a physical basis for similarity of therapeutic effect from widely different adjustments of arc-light mechanisms, giving good



Fig. 4.—Experiment with Dead Frog's Foot.



Fig. 5.—Plate showing effect of ultra-violet rays upon growth of bacteria. V, ultimate edge of visible violet rays, to the right of which is the visible spectrum, and to the left the ultra-violet.



values in white light, but at the same time it substantiates the use of mechanisms arranged to give the maximum of the visible and invisible ultra-violet frequencies.

A third series of experiments was then made to determine which rays were active in exciting reaction on the part of the tissues. These, while suggestive, are not yet regarded as conclusive.

The shaved skin of a rabbit, anesthetized to secure absolute quiet, was subjected to the spectrum, with the same spectroscopic arrangement as before, and no effect whatever was produced after an exposure of two and three-quarter hours, with a current of 25 ampères. Guinea-pigs, white rats, frogs, and even a human arm were similarly subjected to the same spectrum, but with absolutely no evidence of tissue reaction whatever.

An additional experiment seemed to show that the rays exciting this reaction exist somewhere in the ultra-violet region. A rabbit shaven on both sides of its body was subjected to the action of the light (25 ampères of current) passing through the water-circulating apparatus. Contact was made with the quartz disc on one side for 5 minutes. Then the other side was exposed in the same fashion, save that a sheet of glass was inserted between the water-cooling apparatus and the skin. The second exposure lasted an hour and was made with a current of 25 ampères. On the following morning, on the side exposed to the rays through glass for an hour, absolutely no effect had been produced on the skin, while on the side exposed but 5 minutes through quartz, and without the intervention of glass there was a well-marked redness.

This, the author has clearly substantiated in the therapeutic uses of apparatus arranged with (1) glass plates or discs, (2) quartz discs, and also in experiments made upon culture plates, the bactericidal effect being active with the quartz, absent with the glass. The well-known transparency of quartz to the extremely short and high frequencies, ultra-violet, and their loss or absorption upon the interposition of

glass, accounts for the results obtained both experimentally and therapeutically.

All rays of the spectrum, save the greater part of the ultra-violet, readily penetrate glass, and any effect obtained with apparatus containing lenses or globes of glass is evidently due to the feeble penetration of a few of the frequencies on the extreme edge of the violet as it merges into the ultra-violet region. To obtain the maximum effect of ultra-violet frequencies when combined with blue-violet is to secure the maximum result in the treatment of such pathologies as lupus vulgaris, as has been done by Finsen.

It is then clearly proven that the frequencies which excite tissue reaction are to be found in the ultra-violet region, but it is not yet accurately determined in just what portion of the ultra-violet spectrum they are located.

In view of the results obtained with the spectroscope on bacteria culture plates Bernard and Morgan made experiments additionally with the spectra of various metals, such as iron, cadmium, silver and aluminum. The results agreed entirely with those obtained from the carbon spectra, save that the bacterial action was intensified in proportion to the number and intensity of the lines or frequencies in the bactericidal region of the spectrum. From the number of the lines in the spectrum of iron it was concluded that an electrode composed entirely or partly of iron should be found more actively bactericidal than a carbon one. This proved to be the case. The form of electrode found to be most convenient in these experiments was that in which, in the case of the positive electrode, the soft carbon core was removed and in its place was substituted a mixture consisting of the particular metal it was desired to use, with sufficient carbon in the form of sugar to prevent the core from dropping out when in use. The negative electrode was unchanged. The respective electrodes were then fitted into the arc lamp, and the bactericidal power tested on a hanging drop specimen of bacillus coli communis. The slide on which the hanging drop cover slip was placed was com-

posed of quartz, in order that the ultra-violet frequencies might be intercepted as little as possible. The hanging drop thus mounted was placed on the water-circulating apparatus, the light from the arc being projected from below upwards on to the hanging drop. In making these various electrodes in the arc lamp, it was found that the time required to destroy the bacilli, with, in each case, a current of 11 ampères, at a distance of 10 cm. from the arc varied as follows:

Ordinary carbons .....	30	minutes.
Carbons charged with silver.....	30	"
Carbons " " iron .....	15	"
Carbons " " cadmium .....	15	"
Carbons " " aluminum .....	25	"

To ascertain whether the bacilli were killed or not the hanging drop was examined from time to time under the microscope. When all the motility had ceased, the cover slip with the hanging drop upon it was dropped into a tube of peptone beef broth. This tube was then incubated at a temperature of 37°C. for some days to see if any growth resulted.

From the table above it will be seen that carbon electrodes charged with iron and cadmium have twice the bactericidal effect of ordinary carbons; and the cadmium carbons seem to be preferable to the iron ones, as they burn more steadily in the arc lamp. There is a good deal of evidence pointing to a bactericidal power on the part of the blue and violet frequencies, almost equal to the ultra-violet, but these spectroscopic experiments, as well as the following, indicate that such is not the case.

An ordinary glass slide was used, though the light from the arc was passed after having been cooled by transmission through a water-circulating apparatus. The electrodes used were charged with cadmium. Although the motility of the bacilli was stopped after an exposure of 55 minutes, they were not killed even after an exposure of an hour and 20 minutes, that is, in a period five times (a

little more than five times—15 minutes against 80) longer than was necessary to kill the organism when the quartz slide was used. This shows that the visible chemical frequencies, the blue, indigo, and violet, which readily pass through the glass are not bactericidal under these conditions, or only slightly so. The glass intercepted the ultra-violet frequencies, preventing, therefore, their bactericidal power. Comparison was also made between the results obtained with the hanging drop culture, as just described, and those obtained from superficially inoculated agar plates, under the same conditions, and it was found that although half an hour was required to kill the bacillus coli communis in the hanging drop exposed to the light, the same result was obtained on an agar plate in 5 minutes. Or, in other words, six times as long is required to destroy the bacilli when they are suspended in a fluid medium.

This observation led to still another experiment, viz., to determine what proportion of the bactericidal frequencies is absorbed by the thickness of water they have to traverse in the water-circulating lamps employed therapeutically.

To determine the influence of this factor the following experiment was made: The water-circulating apparatus, as already described, consisted of a short brass tube with an inlet and outlet for water, the ends being closed with a quartz disc. The distance between the quartz discs was 2.5 cm., and represented the depth of water to be traversed by the light. An extended image of the arc was projected on to an agar plate, which had been superficially inoculated with the colon bacillus. The arc image was obtained by means of a pinhole in the metal plate interposed between the light source and the agar film. A projected image of the positive and negative poles and of the image of the arc resulted. They found, however, that under these conditions the loss of light was so considerable that a very long exposure became necessary, and, therefore, substituted for the pinhole a metal plate with a slit in it. The slit was less in width than the length of the arc itself, and was placed about 3 cm. from



the arc, with the direction of slit at right angles to the axis of the carbons.

An image was thus obtained which was in reality made up of a number of superimposed images similar to those obtained with the pinhole arrangement. On the agar plate the image was seen as a central broad violet band, above which was the narrow white band of light projected from the negative carbon, and below the brighter white band projected from the positive electrode.

As heat might be a possible disturbing factor, the images from the electrodes were eliminated from the experiments, only the effects of the broad violet band from the arc itself being considered.

Although they had no absorbing medium other than air between the arc and the agar plate, the light was almost free from heat rays, any possible rise of temperature being quite negligible. Inoculated plates were then exposed in the first instance without any heat-absorbing apparatus, and subsequently with a water-circulating apparatus interposed between the slit and the inoculated agar film.

It was found that an exposure of 5 minutes without the water-circulating apparatus had a greater bactericidal effect at a point of incidence of the light than a 25 minutes exposure with it. In other words, that the light on passing through 2.5 cm. of water lost four-fifths of its bactericidal power. This result they had hardly anticipated in view of the researches of Hartley and others, in which water was shown to be but slightly absorbent either to visible or ultra-violet radiations.

The loss of bactericidal power may, however, be attributed to general rather than to selective absorption. The quartz may be regarded as negligible, as its transparency is well known, and they subsequently found that it transmits the bactericidal radiations practically without any loss of absorption. It would, therefore, appear that in photo-therapeutics the generally used water-cooling appliance might well be dispensed with if the heat could be eliminated by

other means, and assuming that the directly bactericidal rays are the only essential ones, which at present is by no means certain.

The next experiment was to determine whether, when using the electric arc, the effect is in any way a function of any particular current. It was well known that the efficiency of an arc as a source of light increases as the current is increased. The ratio of light production is approximately as follows, the standard in this case being an efficient type of oil lamp :

7 ampères .....	39	15 ampères .....	117
10    "        .....	75	20    "        .....	160

"On exposing bacterial plates in the above-inversed ratios we found that the action was exactly proportionate to the light produced, a current 10 ampères having approximately double the bactericidal effects of a current 7 ampères and so on. This was tested carefully up to 25 ampères with unvarying results, showing that the action is exactly proportionate to the light efficiency."

While the colon bacillus was used principally, Bernard and Morgan also employed the following organisms with similar results: bacillus prodigiosus, bacillus subtilis, micrococcus tetragenus, staphylococcus aureus and bacillus tuberculosis.

These experiments conclusively establish that while quartz transmits the bactericidal frequencies without any absorption, quartz used in connection with water-cooling apparatus is much less active, as a part of the active frequencies are absorbed by the water. The best therapeutic effect has been obtained by the author from using the source of light; (1) in general conditions all the radiant energies of the arc, (2) in local lesions direct from the arc through a compressing lens of quartz only, without the intervention of water.

Now that the frequencies which excite tissue reaction are so exactly located in the spectrum and the bactericidal region is definitely known, it will be possible to have light mechan-

isms so arranged as to give the maximum effect. Then it will be a question of administering the active principle of light energy, with the precision of drug therapy.

This work of Bernard and Morgan, although substantiating the work of Finsen and many other observers, is the first to definitely locate the active bactericidal frequencies. It will go far toward placing the therapeutic use of light energy on an absolutely scientific basis, as against its somewhat empirical use as still practised to-day. Clinical work points also with unerring fidelity to the need of a source of light energy rich in chemical frequencies, ultra-violet especially, where it is desired to excite tissue reaction by a localized application.

The question of bactericidal action is not the paramount one, but it is the ability of the same frequencies (ultra-violet) to excite intense tissue reaction upon which therapeutic results depend.

The frequencies of the red and green regions of the spectrum are neutral, and some observers have appeared to find them favorable to the growth of bacteria. All the evidence, however, places the bactericidal activity at the end of the spectrum most intensely chemical in its action, viz., the more refrangible blue, violet and ultra-violet frequencies, while the most recent and only spectroscopic experiments exactly locate them in the middle third of the ultra-violet region.

Sensitization of Bacteria.—As the gelatin bromide plates grasp the waves of short and high frequency with which space is filled by the millions and hold their energy fast, in particles of silver, so recent investigators<sup>1</sup> have endeavored to utilize the energy of longer and slower wave lengths, green, yellow, and even red, by rendering the tissues *sensitive* with suitable substances just as is the bromide plate.

All accumulated evidence shows that the bactericidal fre-

---

<sup>1</sup>Schlesische Gesellschaft für vaterländische Kultur by Professor Neisser and Dr. Halberstadter, Section of Medicine, Deutsche Medicinische Wochenschrift, Feb. 18, 1904. Reviewed by Stephane Leduc, Archives d'électricité.

quencies and those exciting tissue reaction, i.e., blue, violet and ultra-violet, or the most refrangible of the spectrum, possess the least penetrative power, while the less refrangible frequencies, green, yellow and red, have the greatest penetrative power.

The question arose in the mind of Dreyer,<sup>1</sup> of Copenhagen, as to whether living tissue does not comport itself as does a photographic plate, and if the same substances used for the latter will not act upon the former and render them sensitive to the green, yellow and red frequencies of the spectrum.

The following experiments were made by Dreyer: cultures of prodigiousus, and also of the infusoria nassulo were placed in a small quartz chamber, cooled by a circulation of water, the liquid was sensitized by a 1/5000 solution of erythrosin, which by itself is without any action upon infusoria or bacteria. The concentrated light of a 30 ampère arc at 50 volts pressure through a quartz filter was utilized. To study the action of the different frequencies of the spectrum, he filtered the light successively through glass, solution of sulphate of nickel, of chromate of potassium, and of bichromate of potassium. The results are contained in the following table:

Filter	Rays acting	Time after which are dead			
		Infusoria		Bacteria	
		Sensitized	Normal	Sensitized	Normal
Quartz . . .	The whole spectrum including the ultra-violet . . .	10"	100"	60"	80"
Glass . . . .	The visible spectrum . . . .	10"	9'	10'	10'
Sulphate of nickel, 5%	Red, orange, yellow, green and blue . . . .	10"	13'	10'	10'
Chromate of potassium	Red, orange, yellow, and green . . . .	10"	70'	15'	More than 4 hours
Bichromate of potassium	Red, orange, yellow . . . .	10"	110'	25'	More than 9 hours

<sup>1</sup>Mitteilungen aus Finsen's Med. Lichtinstitut—1904, Heft VII.

The action of the less refrangible frequencies of the spectrum upon sensitized infusoria and bacteria is very strikingly shown by the results of Dreyer's experiments.

A 30-minute exposure of a culture of prodigiosus to the quartz spectrum of a lamp 26 ampères, the non-sensitized bacteria were only killed in the ultra-violet; while in the cultures sensitized by erythrosin death is produced by the orange and yellow frequencies also. These have been rendered equally active with the ultra-violet by reason of the erythrosin solution in which the cultures were placed, and which has served to store the energy of the orange and yellow frequencies. In the doing of this a chemical action takes place just as with the silver of the bromide plate in photography, an action which is disastrous to the integrity of the micro-organisms. Dreyer found that the animal tissues were also capable of being rendered sensitive to the action of the orange and yellow frequencies. This he established experimentally upon tadpoles, rabbits, and upon the human skin. With concentrated light acting through 1.25 mm. of skin Dreyer was able to kill in 32 seconds sensitized infusoria; but when non-sensitized under the same conditions death only ensued after 60 minutes.

Sensitized bacteria treated in the same manner died after 20 minutes, while the non-sensitized were still alive after 11 hours.

Thus it is shown experimentally that both bacteria and the tissues can by being covered with suitable media be rendered as sensitive to the longer, slower, less refrangible and more penetrating frequencies as they are to the very little penetrating frequencies of the ultra-violet. This action, according to Leduc,<sup>1</sup> does not in any sense depend upon fluorescence; for there are sensitizing substances which are not fluorescent, and fluorescent substances which are not sensitizing.

There are, for example, fluorescent substances which

---

<sup>1</sup>Ibid.

absorb energy of radiation at the same degree of erythrosin, but they are not sensitizing—i.e., they absorb the energy of the more refrangible frequencies, but do not emit them at a lower or less refrangible degree of radiation. On the contrary they fix or store the energy. This means work done—just as surely as the impression made upon the photographic plate by the silver bromide, nor is there any formation of toxic material by the action of light upon the sensitized liquids. If such a liquid is exposed to the light first and the infusoria or bacteria placed therein, no lethal action follows.

The experiments reported by Dr. Halberstadter confirm at every point the researches of Dreyer, not only upon the sensitized infusoria and bacteria but upon living tissue as well. The direct physical action of the bactericidal or ultra-violet frequencies upon bacteria is due to their short lengths and high frequency, i.e., the inconceivable rates at which they swing to and fro in their own free paths of oscillation. In so doing they have the power to agitate little things which appear in their path, such as molecules. By the profound agitation to which the bacteria are subjected by these frequencies, the death of the germ is assumed to result. It seems very probable that by this agitation they are worried very much in the same fashion as the small animal, mouse or rat, is when shaken to death by a dog or cat. This physical agitation in turn gives rise to a chemical process which insures the death of the bacteria.

Mechanical Agitation Destructive to Germs.—Mechanical agitation of germs is destructive to them. The *Lancet*<sup>1</sup> cites an instance where bacterial cultures were allowed to stand in the engine room of a large manufactory where there were incessant vibrations from the strokes of the engine. After four days the germs were destroyed and did not appear when the water was set in a quiet place. It is reported that Dr. S. J. Meltzer<sup>2</sup> has demonstrated that incessant vibrations of the stroke of an engine and violent shocks

---

<sup>1</sup>London *Lancet*, Feb., 1903.

<sup>2</sup>The *Sun*, Feb. 14, 1904.

are destructive of germ life. He found that the number of germs in the agitated fluid in no instance amounted to as much as one-tenth of those in the unshaken samples. It was also observed that the restriction in production increased with the duration of the treatment and that when the treatment was applied for a sufficient length of time the liquid could be freed from bacilli. The complete annihilation of the germs was accomplished in 10 hours of agitation, when sterilized glass beads were added to the culture.

Different organisms were found to have different degrees of resistance, so that it was possible to eliminate them successively from a solution by regulating the shaking process. The cells thus split up did not form any visible debris, but resolved themselves into a fine powder, which offered no distinguishing features under the microscope. Because of this it was concluded that there was in no sense a mechanical disruption of the cell, but that the effect was due to a chemical action.

From the physical point of view, the energy of oscillating light corpuscles is given up in the non-thermal mechanical agitation to the molecules, and this in partly atomic agitation or chemical change and the rest in heat or vibrations of the molecule; now if the molecular structure of the bacilli is unduly agitated by the swing of the oscillating light corpuscles, the ultra-violet frequencies, the energy given up to them must be of such a nature as to result in atomic agitation or chemical change which involves the giving up of their contained oxygen, so necessary to continued vitality.

In the living tissue while a direct lethal effect cannot be produced upon them by reason of their environment the atomic agitation would undoubtedly interfere with their vitality, and by reason of a chemical change. It would seem from experimental data and clinical observation that the same frequencies of light energy which unduly agitate bacilli, act as a physiological stimulus to the red blood corpuscles, increasing their oxygen-carrying capacity and therefore the oxidative processes of the entire organism. A certain vibra-

tional activity is necessary to life, still another to the maintenance of health, while a third or greater degree is destructive of life. For example, in the phenomenon of heat we have a vibrational activity—a mode of motion, and yet “a few degrees change in temperature either way will end the evanescent, fleeting, unstable and feeble thing or entity—life which was the last to appear in the midst of the stupendous cosmic war of matter and energy, and will be the first to vanish.”<sup>1</sup> And the concentrated vibrational activity of the ultra-violet end of the spectrum, while borne in therapeutic doses by the higher organism, is fatal to the life of the lower.

This destructive action of light energy upon microorganisms is assumed to be (1) on the plasma of the bacteria directly and (2) at the same time to be indirectly injurious to the nutritive basis, by producing a photo-chemical change. In other words there has been expended an energy, capable of establishing chemical change, which influences not only the nutritive basis, but also normal physiological action, all of which tends to the rendering of bacterial toxins inert and the removal of the detritus.

It was observed by Kruse<sup>2</sup> that by subjecting sterile nutritive bases to light, complex chemical bodies (peptones) were formed which checked development.

Richardson<sup>2</sup> proved that in fresh urine under the influence of direct illumination, peroxide of hydrogen is formed, which is decomposed by the bacteria, the latter being killed by the liberated oxygen. Dieudonne showed that through the chemical action of light upon water, peroxide of hydrogen is formed, most freely in the upper layers. As is well known, this compound is strongly antiseptic.

Bactericidal action is very largely diminished under exposure to light when oxygen is excluded, as evidenced by the experiments of Dieudonne, Tizzoni and Cattani.<sup>3</sup>

---

<sup>1</sup>Larkin: Radiant Energy.

<sup>2</sup>Freund: Radiotherapy.

<sup>3</sup>Arch. f. Exper. Pathologie und Pharmakologie, Vol. XXVIII., p. 54, also Freund.



The explanation of this lies in the fact that peroxide of hydrogen cannot be formed under these conditions.

The most important factor in the human organism the author believes is to be found in the effect of the light energy upon the nutritive bases of bactericidal growths *pari passu* with its physiological action upon the entire blood stream. This action is characterized by an increase in the amount of oxygen, which experimental data shows to be so prejudicial to the well being of micro-organisms.

Outside of the living organism there is a direct injury to the protoplasm. Dried spores from all nutritive material, as both Ward and Kruse have shown, are killed by sunlight.

The movement of bacteria is also influenced by the action of light as well as their development and growth, both of which are checked.

Winogradsky<sup>1</sup> and Beijerinck<sup>2</sup> found that sulphur bacteria and the chromogenic bacteria always collect at the lightest spot, and they are thus positively phototaxic. This action is considered more at length under the action of light energy upon the elementary forms of light.

It is not only a generally accepted fact that light lessens the receptivity of an organism to living bacteria and to bacterial poisons, but the subject has been investigated experimentally demonstrating its truth by Kondratjen, Gebhard and Jousset.

Baeder,<sup>3</sup> who investigated this point with great care, considered it an open question.

Summary.—(1) Light energy is then not only a bactericidal agent of considerable power, but (2) the action is due to the more intensely chemical frequencies blue, indigo, violet and ultra-violet; while (3) there is no bacterial species which can resist the power of light if the light be intense

<sup>1</sup>Zur Morphologie und Physiologie der Schwefelbakterien. Quoted by Freund.

<sup>2</sup>Centralblatt f. Bakteriologie, Vol. XIV., p. 844. Quoted by Freund.

<sup>3</sup>Quoted by Freund.

enough, sufficiently concentrated and exposed for a sufficient length of time.

From the chemical point of view the bactericidal power of light energy is a phenomenon of oxidation. For its successful action the presence of oxygen is necessary.

The Production of Light by Micro-Organisms.—It is a matter of common knowledge that certain organic substances, meat and fish, for example, especially salt-water fish, when the process of decomposition is first established, give off a more or less phosphorescent light, which is naturally most plainly visible in the dark.

Pflüger<sup>1</sup> was the first to observe that this peculiar phenomenon was an expression of the activity of micro-organisms. Since then Ludwig,<sup>2</sup> Fischer,<sup>3</sup> Beijernick,<sup>4</sup> Katz,<sup>5</sup> Giard,<sup>6</sup> and others have made pure cultures, and described a great number of photogenic bacteria. In this connection Fischer pointed out that even the *ignis fatuus* is to be explained as a bacterial phenomenon.<sup>7</sup>

The intensity of the light given out by the different bacteria varies greatly: the color also may differ, being white, bluish or greenish. Fischer found upon spectroscopic examination, in the case of one bacterial species, a continuous spectrum from the D-line to slightly beyond the G-line with a maximum intensity between G and F. The strength and extent of the *ignis fatuus* in tropical waters is a matter of common observation and description. The phosphorescence of micro-organisms may be so great as to permit of telling the time of day; while photographs of cultures have been taken by the light produced by themselves.

---

<sup>1</sup>Pflüger's Archives f. d. Gesamte Physiologie, Bd. X., s. 275 und Bd. XI., s. 222.

<sup>2</sup>Zeitschr. f. Mikroskopie, I.

<sup>3</sup>Zeitschr. f. Hygiene u. Infektionskrankh., II. Centralblatt f. Bakteriologie, III.

<sup>4</sup>Ref. in Koch's Jahresber. 1890, s. 180.

<sup>5</sup>Centralblatt für Bakteriologie, IX.

<sup>6</sup>Ref. in Centralblatt f. Bakteriologie, VI.

<sup>7</sup>These lights can, however, also be produced by other photogenic organisms, for example, by *Peridinia*.

Bacterial Lamps.—In this connection it cannot fail to interest the reader to quote from Molisch's<sup>1</sup> communication to the Vienna Academy of Sciences in reference to the photographic and illuminating power of micro-organisms in which he said he had been able to photograph phosphorescent cultures of bacteria after an exposure of 5 minutes, by their own light. In order to photograph other objects by means of this bacterial light, he constructed a special bacterial lamp. This consists of a large flask, whose interior is lined with salt-peptone-gelatin, previously inoculated with bacteria. On the second day following the inoculation the lamps begin to glow with a beautiful bluish-green light, due to the phosphorescent colonies growing within. These living lamps have the property of shining with undiminished intensity for two or three weeks, and then gradually diminishing in strength. Their light is sufficient to permit one to recognize the face of a person standing two yards away, to tell the time, to read a thermometer, or even large-size print. In view of the freedom from danger of such a cold light, its use in mining operations or in powder magazines may become of importance. Organic light, particularly the rays emanating from glowing insects, such as the so-called glow-worm, has been made the subject of many investigations, and it was even asserted that this light has the properties of the Roentgen rays. Molisch, however, proved this view to be erroneous, as bacterial light acts just like ordinary light.

The Free Access of Oxygen Necessary for the Phosphorescence of Bacteria.—Of first importance among the necessary conditions for bacterial phosphorescence is the free access of oxygen. If the culture be in a solid medium only the upper layers are illuminated while a fluid medium on the contrary by shaking with air may be made luminous throughout its whole extent.

---

<sup>1</sup>The N. Y. Sun, March 15, 1903, and the International Med. Magazine, Oct., 1903.

The Influence of Temperature in the Phosphorescence of Bacteria.—This phosphorescence is influenced by the surrounding temperature. If very high or very low the fluorescence is prevented, even though the bacteria continue to live. The limits within which they live are wide, but dependent amongst other things upon the temperature.

Forster<sup>1</sup> found that a pure culture of a salt-water bacterium retained its power of light production and reproduction at 0°. Tollhausen<sup>2</sup> succeeded in reducing a culture of photogenic bacteria to -12° without the complete cessation of phosphorescence.

The Necessity for the Presence of NaCl to Insure Phosphorescence of Bacteria.—It has been shown by various experimenters, that all the light-giving bacteria require quite a high percentage of NaCl in the culture medium in order to be able to produce light. The water of the sea is, therefore, particularly suitable for the preparation of the different media.

Two theories have been adduced with regard to the light production of bacteria :

1. The production of light is a direct function of living protoplasm, and, therefore, just as inseparable from it as heat production.

2. The living cell produces and gives off a substance (photogen), which outside the cell is luminous.

Dubois<sup>3</sup> claims to have found such a photogen even in crystalline form, and Ludwig<sup>4</sup> asserts that, in the case of the micrococcus pfluegeri, it is not the colonies themselves but the products of metabolism, which give off light. All other researches with regard to photogen have led to negative results, and the theory mentioned under 2 can, therefore, not be considered as proven.

In general it may be said that light has no effect upon

<sup>1</sup>Centralbl. f. Bakteriologie, II. s. 337.

<sup>2</sup>Untersuchungen über Bakt. phosphorescens Fischer, Diss. Würzburg, 1889.

<sup>3</sup>Comptes Rendus de l'Academie des Sciences, Bd. CVII., s. 502.

<sup>4</sup>Centralbl. f. Bakteriologie, Bd. II., s. 40.

the phosphorescing power of bacteria, only Dubois<sup>1</sup> mentions a diminution in light production in bacteria that have been exposed to light for several days. The fact that the ignis fatuus can take on such extreme forms in the tropics, even when the sky is cloudless for days, would indicate that at least one form of light-producing bacteria possesses a comparatively great resistance to sunlight. A study of the action of concentrated electric light on these forms would be interesting.

The Action of Light on Vaccine, on Bacteria, Toxins, Enzymes, etc.—Finsen and Dreyer<sup>2</sup> have experimentally shown that light, and especially the ultra-violet rays, can weaken or destroy smallpox vaccine. The vaccine was placed in drops on plates of rock crystal and exposed to concentrated light from an electric arc light of 25 ampères, 50 volts; the action of the heat was hindered by sprinkling with cold water, and the results were found by vaccinating children with it thereafter. An exposure to light lasting more than 10 seconds showed plainly a loss of strength in the vaccine, while an exposure of about 200 seconds was required to render the vaccine incapable of producing pustules. A prodigious culture was devitalized by the same illumination inside of 40 seconds. With illumination through blue or clear glass, which kept back the ultra-violet rays, the destruction of the vaccine was accomplished only after 15-20 minutes.

On the toxins of bacteria and all enzymes, which so far have been examined in this respect, light exerts a very destructive action.

Tizzoni and Cattani<sup>3</sup> found that long-continued action of sunlight not only is able to destroy the tetanus bacillus, but also to render inert the tetanus toxins. This destruction took place most rapidly, when there was access to the oxygen of the air. These experiments were verified by those

---

<sup>1</sup>Loc. cit.

<sup>2</sup>Mitteilungen aus Finsen's Med. Lichtinstitut, 1903, Heft III.

<sup>3</sup>Archives f. Exper. Pathologie, 1890, XXVII.

of Fermis and Cellis,<sup>1</sup> according to which the tetanus poison completely loses its toxic action after exposure to sunlight for several days. Later experiments showed a similar conduct with regard to the toxins of other bacteria.

With regard to enzymes, Downes and Blunt,<sup>2</sup> who also included this subject in their extensive and admirable researches, found that invertin was destroyed in sunlight, so that it lost its power to convert cane sugar.

Green<sup>3</sup> has shown by unusually delicate experiments the destructive action of light on the diastatic enzymes occurring in the leaves of plants. This action is derived from the ultra-violet rays, while the blue, and especially the red rays, possess a favorable action, in so far as they are able to convert the zymogen of the diastase into an active form.

Schmidt-Nielsen<sup>4</sup> undertook lately in the above-mentioned laboratory a series of experiments with regard to the action of light on chymosin (rennet). He exposed it to light in small chambers whose walls consisted of quartz, and used as a standard of measurement (for the action of the light) the time required by 0.1 cm.<sup>3</sup> enzyme solution to coagulate 10 cm.<sup>3</sup> milk at a temperature of 37°. Non-concentrated electric light and sunlight had very little influence on the chymosin, while a very short exposure to concentrated electric light lengthened the coagulation time quite materially. The action was ascribed to the ultra-violet rays, and the insertion of a piece of clear glass was sufficient to prevent this action. When the chymosin, after illumination, was kept in the dark an after effect was plainly noticed after one day.

An attempt to make the enzyme sensitive to the rays which can be seen, by the addition of a sensitizer (erythrosin) gave negative results. As above mentioned, however,

---

<sup>1</sup>Ref. in *Centralbl. f. Bakteriologie*, 1892, XII., No. 18.

<sup>2</sup>*Proceedings of the Royal Society of London*, Vol. XXVIII., s. 205.

<sup>3</sup>*Philosophical Transactions of the Royal Society of London*, 1897, Vol. CLXXXVIII., s. 167-190.

<sup>4</sup>*Mitteilungen aus Finsen's Med. Lichtinstitut*, 1904, Heft IX.

Tappeiner<sup>1</sup> showed that enzymes as well as toxins can be sensitized<sup>2</sup> by the use of eosin and magdala red.

On the chymosinogen—the zymogen or proenzyme of chymosin—the ultra-violet waves exerted a deleterious action similar to that on rennet, and contrary to Green's above-mentioned experiment Schmidt-Nielsen found that the red rays did not possess any active influence. Ordinary blood serum has the power of preventing the activity of enzymes, the active substance here—antichymosin—is also weakened by the action of light.

The Action of Light Energy upon Hygiene and Sanitation.—From this array of evidence a practical deduction is to be made, viz., the influence of light in hygiene and sanitation. It is a perfectly well-known fact but not one that is lived up to even by the profession. The author would recall the experiment of Momont with the blotting paper saturated with charbon blood, the experiment of von Esmarch as to the extent of the action of light energy in destroying micro-organisms contained in bedclothing, of the purification of water by light energy. of the action of the electric arc upon noxious odors, to emphasize the need of the energy of light to keep our houses and hospitals pure. Disease will not breed in houses flooded with sunlight and air. The action of the sunlight is to destroy millions of morbid germs daily, not only in the air and on the surface of the soil but also in the water of streams. The latter has been shown by the experiments of Buchner, Praunitz<sup>3</sup> and Procaccini.<sup>4</sup>

The habit of keeping the window shades down, a very common practice even in the absence of direct sun glare on the window, is in direct opposition to fundamental physiological principles. Sunlight is not only purifying to our atmospheric environment, in its destructive action upon micro-organisms, thereby preventing disease, but it has a

<sup>1</sup>Berichte d. d. Chem. Gesellschaft, 1903, Bd. XXXVI., s. 3035.

<sup>2</sup>See Sensitization, Chapter XX.

<sup>3</sup>Influence des égouts de Munich sur l'Isar, Munich, 1889.

<sup>4</sup>Influence de la lumière solaire sur les eaux d'égouts. Annalé de l'Institut d'Igaine sperimentale, t. III., 1893.

still more deep and intimate human relation of a sanitary nature, for an abundance of light energy is a necessary condition of mental and bodily well-being. The recognition of its tonic psychical power is universal; the practical application not always made. In all properly organized peoples there is a love of light, and a fear of darkness is not confined to children. The sense of powerlessness, danger and alarm which the latter induces is shown by adults as well. Light energy is essential for all the purposes of life, for the supply of oxygen upon which existence depends. It is a universal stimulus. When it falls upon the eye there are established functional activities in the brain which are associated with intellectual and emotional states. That the blue frequencies exercise a depressing effect and the red an exciting effect upon the brain seems well established; but in this connection it is neither the one nor the other which is considered but a complex of all the frequencies, heaven's own mixture the white light, that envelops us with its all-pervading energy, which is the normal psychical atmosphere. Variations in its intensity have in all probability widely different constitutional effects. But although the quality and intensity of light energy demanded by the individual living organism may vary, the need for it and dependence upon it is imperative for all.

The influence of solar light as a disinfectant is chiefly upon the surface of translucent or opaque bodies. Any medium which cuts off the chemical frequencies from the blue into the ultra-violet region, as glass, dust and fog, as well as a clouded atmosphere, prevents this disinfectant process, so necessary to perfect hygiene and sanitation. Consecutive days of rain, mist and fog give an opportunity for the growth and development of pathogenic organisms. They usually are followed by epidemics more or less severe of the diseases dependent upon the activity of these germs.

Houses that are closed for several months in the year should be left with the shades all up and curtains looped back, in order that the sunlight may penetrate every nook



and corner. In this way the growth of germs inimical to health will be prevented. And not only when they are closed but when occupied they should be flooded with sunlight. For this reason, heavy curtains which obstruct the ingress of the sun's rays are pernicious in the extreme. They not only exclude the light, but they readily become saturated, so to speak, with germ-laden particles of dust, and it remains only for the occupants of the house to become a little worn, tired, anæmic, from over care and anxiety, or in women from an exhausting menstrual flow, for these germs to find a fit lodging within the tissues and to actively develop.

By the action of those frequencies which penetrate and are absorbed, physically, there is established a synchronous vibration with oxygen molecules, which results in an impartation of energy and an increased oxidative power.

Thus the chemical activities of light serve in hygiene, sanitation, and also in disease: In the one instance to maintain health, in the other to disinfect or destroy pathogenic organisms, and in the latter to check the inroads of disease by increasing not only the red blood supply but the white as well and the functional activity of the entire organism.

## CHAPTER VI.

### The Action of Light Energy upon the Higher Organisms.

Introduction.—There is in animals as in plants a stimulating influence on the functions of tissue elements and organs by the action of light. The impartation of energy to the living organism is transferred into a stimulus by which all the vital processes are quickened and heightened. There is produced by this stimulus of light either a direct influence upon the irradiated protoplasmic cells, or there is brought about indirectly, through the sense organs and nerves, certain functions on the part of given organs.

The Influence of Light upon the Development of Animals and Man.—The development of many animals is dependent on light and without it development proceeds slowly or is suspended altogether. It was observed by William Edwards<sup>1</sup> that frog spawn in an opaque glass died, while spawn in a transparent glass became duly developed.

Tadpoles develop more slowly in the dark than in the light. Schnetzler's<sup>2</sup> experiments prove that white light is more favorable to such development than green.

The degree of development of animal organisms is influenced differently by the different frequencies of the spectrum.

---

<sup>1</sup>De l'influence des agents physique sur la vie, Paris, 1824.

<sup>2</sup>Archives des Sc. Physiques et Naturelles, 1874, Vol. LI.

It was observed by E. Yung<sup>1</sup> that violet light helped on the development of the embryo of rana, salmo, and lymema, which was hindered or disturbed by other parts of the spectrum or by darkness.

Beclard<sup>2</sup> observed that flies' eggs develop more quickly under blue and violet glass than under red, yellow, green or white.

Guarinoni<sup>3</sup> from his experiments believes that violet light acts more favorably on silkworms; while Goodnew noticed that maggots are much more quickly developed in pieces of meat exposed to the light than in meat kept in the dark. In his study on the activity of light on polypi Loeb found that the growth is not especially influenced by all the rays, but that only the more refrangible, that is, the blue rays, promote growth. The same effect on the other hand is produced by red in darkness.

Recently Leredde and Pautrier<sup>4</sup> have made a study of the development of animals under the influence of the energy of different parts of the spectrum. As subjects of experiment, tadpoles of the common rana temporaria were used. The solar spectrum divided into two parts was used; the one comprising all the energy from the green, blue, indigo and violet, and the other the energy from the red. Two aquariums were constructed, one of photographer's red glass, colored with proto-oxide of copper, and the other of blue glass colored in cobalt blue. Each was covered with a glass of the same color as the aquarium, leaving just space enough for oxygen renewal. Examined spectroscopically the red glass permitted the passage of all the rays up to the line D, that is to say all the red and the beginning of the orange; for the blue glass the violet, indigo blue and the beginning of the green. The tadpoles subjected to the experiment were caught the same day in the same pond and preserved for

---

<sup>1</sup>Comp. Rend. Acad. des Sc., Vol. LXXXVII.

<sup>2</sup>Compt. Rend., 1858.

<sup>3</sup>Quoted by J. M. Eder, Ueber die chem. Wirkungen d. farb. Lichtes, Vienna, 1879.

<sup>4</sup>Leredde and Pautrier, Photobiologie et Photothérapie.

some days in a large white bell glass. They presented no differences of tail, size or development. They were divided into three groups, one of which was placed in the red aquarium, another in the blue while the third was put in the white bell glass to serve as a control. Other than the difference in the energy of radiation to which they were exposed all other conditions were exactly the same. The food was the same for all and was provided by the water of the pond, which filled the aquariums and which furnished infusoria, Daphnes and Cyclops. The illumination was always bright, as the aquariums were either placed in the garden of the dermatological establishment or before the laboratory window. The intensity of the light employed ought to be considerable, as it is reduced considerably by filtration through the colored glass. When feeble diffused light is employed, it is equivalent to darkness in the centre of the aquaria, however thin the glass may be.

At the end of a month there was the greatest difference in the tadpoles of the red and blue aquaria. In their book, Leredde and Pautrier present photographic illustrations, showing these differences. In each of the aquaria one died. Of the three survivors in the red aquarium, they were all still in the tadpole state with their caudal membranes. One of them had two pairs of feet feebly developed and breathed by the pulmonary method, but the other two had no rudimentary members, moved themselves simply by their nautatory membrane and breathed by the bronchial method, the bronchi being covered by a cutaneous operculum. On the other hand the three tadpoles raised in the blue-violet light had no longer caudal membranes. They were represented only by a little stump in process of disappearance. Their two pairs of feet were completely formed and they respired well by the pulmonary method. The photographs showed these differences very clearly—on the one side there are true tadpoles almost analogous to fish, on the other true frogs almost completely adult. The experiments of Leredde and Pautrier were also made to show the greater activity in

cellular division, which alone could explain the apparent differences and also to measure this karyokinetic activity. To this end a tadpole of a urodel batrachian, the *Triton Cristatus*, was selected. This tadpole presents a caudal membrane which is excellent for the purposes of study. Although it contains a great number of chromatophores it is very little pigmented and so small that if it is carefully cut off and skinned in the direction of its thickness it is an excellent subject for the study of the yellow elements, conjunctival cells, capillaries in formation and epithelial cells in karyokinesis.

Larvæ of the triton were kept for three weeks in blue and in red aquariums. Their caudal membranes were then removed and the preparations colored with hematin-eosin. The preparations were then examined by the movable graduated stage, as in examination of the blood, to establish the leucocytic equilibrium. Section by section was examined, counting 4,154 epidermic cells in the sections from the tritons raised under blue glass. In these they found 52 figures of cellular division or a little over  $1/79$  of the cells in karyokinesis. Upon examination of the tritons raised in the red aquarium they counted 2,613 cells and 14 in karyokinesis, or about  $1/186$  of the entire number.

Subsequent to their experiments they found that Jakimovitch<sup>1</sup> had reported similar experiments in a Russian publication with similar results. He also observed that the larvæ of tritons developed better in light than in darkness, and that the karyokinetic activity of tadpoles grown under different lights was sensibly greater under violet energy than under the energy of all the other frequencies. He made his observations upon the bronchi rather than the caudal membrane, however.

The conclusion is, therefore, reached that light exercises an incontestable influence upon the development of the higher organisms, and that in the phenomena of karyokinesis the violet is the most active.

---

<sup>1</sup>Westnick *obchestvenog hygieny*, Aug., 1891.

The Influence of Light upon the Movement of Animals.—There is observed among the higher organisms the phenomenon of movement under the influence of light. These movements are analogous, in a higher scale, to the phototactic movements of unicellular growths, studied under the influence of light energy upon the elementary forms of light.

The simplest manifestations of this phenomenon is in the lower forms of animals, where the nervous system is rudimentary.

In this connection the experiments of Gruber, Dubois, Loeb and Finsen are of interest.

Sensibility of the Cutaneous Investment of Animals to the Chemical Rays.—Gruber's<sup>1</sup> experiments were made upon the *Lumbricus* or ordinary earthworms which have no eyes, and upon some blind salamanders to the end of removing the complications which would arise from the reflex movements due to the action of light on the visual organ. They were found to be sensitive to the presence or absence of light, and also to the different frequencies of the spectrum. They tend to flee from illuminated places and shunned completely the areas exposed to the action of the blue-violet light. These animals seem capable, therefore, of distinguishing between light and darkness, and of recognizing the rays of varying refrangibility. This phenomenon Gruber observed even with decapitated earthworms, and is to be explained by a cutaneous sensibility to the influence of light.

Dubois<sup>2</sup> from similar experiments with proteus has shown that it is most active under the influence of red frequencies, least so under the influence of blue frequencies. He observed this animal flees from blue-violet light to take refuge in the dark.

Finsen<sup>3</sup> has carried out a number of interesting observations as to the irritating properties of the chemical fre-

---

<sup>1</sup>Versuche über die Helligkeits- und Farbenempfindlichkeit augenloser und geblendeter Thiere. Wiener Sitzungsberichte mathem. natur. Klasse, 1883. Bd. 87.

<sup>2</sup>C. R. Soc. de Biologie, 1890, p. 360.

<sup>3</sup>La Photothérapie, Paris, Naud, 1889.

quencies. He observed that very young salamanders lying at the bottom of a dish of water are not disturbed by red or yellow light, but by blue they were quickly excited to movement; the same is true of the ordinary earthworms, which would collect beneath the red and avoid the blue-glass compartment. These were the same results as were obtained by Gruber and Dubois, and it would appear that various animals can distinguish by their integuments between red and blue, and that while they seem to take delight in the former they avoid the latter. So true did he find this from his investigations and observations that he described a specific photodermatic sense. The same thing is true of common house flies. Finsen also observed that solar light determined movements in the fœtus of the frog and of the salamander. He studied these under the influence of monochromatic light, and found that they were exceedingly numerous under the influence of blue light, and very rare under that of red, yellow or green light. He placed three larvæ of the frog just born in demonstration glasses. Upon exposure to the varying frequencies of light energy he found that most rapid movements were produced under the action of blue light energy, and that the maximum effect was only obtained at the end of a certain time of exposure. This is simply the latent period of induction to every physiologic excitant.

Upon placing some tadpoles raised in red light in solar light, he observed them execute some quick movements, while some tadpoles raised under blue light when so exposed were not excited. He also repeated the experiments of Gruber, placing in an oblong box covered with different colored glasses lumbrici, earwigs, and wood lice. These animals all rapidly grouped themselves under the red glass. This simply illustrates that these animals are naturally photophobic, and accustomed to almost complete darkness in their natural haunts, in the earth or under the rocks.

Finsen in another experiment showed that butterflies who are habituated to bright light preferably grouped themselves in the blue light, presenting at the same time the move-

ment of beating of the wings; while under the influence of red light they remained in repose.

Auerbach<sup>1</sup> authorizes the statement that the action of light energy induces powerful contractions of the protoplasm of frog's spawn. Finsen, in his experiments with frog spawn and salamander germs, noticed that light possessed to a high degree the power of inducing movements of the germ. The blue-indigo and violet frequencies have special power in this way.

With an increasing light energy, *daphnia pulex* shows increased precision and swiftness of motion.

Harrington and Leaming, quoted by Freund, state that red light is more favorable to the movements of *amœbæ*, while both the violet and white light have an impeding effect.

The experiments of Parker and Burnett<sup>2</sup> also demonstrate the heliotropic faculty of animals as well as plants. This does not necessarily pertain to animals whose visual organs are intact but is true also of sightless animals. The influence which light exercises upon some animals is of common observation. They are irresistibly compelled by it, it possesses for them a magnetic influence, and they are, therefore, impelled either to turn toward or away from the source of light. In every suburban village in which the streets are lighted with the electric arc there are to be found hundreds of dead insects, moths, etc., about each arc. The attraction is so great that, like the singing of the Lorelei, it impels them to their destruction. Among insects thus blindly attracted by artificial light is the gnat, in whose flame it will singe its wings and lose its life. Wedensky<sup>3</sup> observed that blind frogs will always turn their heads toward the source of light, placing themselves so that its rays may fall symmetrically on both sides of their bodies. Bert<sup>4</sup> observed that when frogs were placed in a box, one-half of

<sup>1</sup>Quoted by Freund, page 412.

<sup>2</sup>American Journal of Physiology, IV., 8, p. 273.

<sup>3</sup>Bull. de l'Acad. des Sc. à Petersburg, 1879.

<sup>4</sup>Revue Scientif., 1878, 42.



which was illuminated and the other half dark, that they would always try to get to the bright part.

With animals, as with plants, there are those which instinctively seek shady and dark places, seeming to have an instinctive dread of light.

It has been shown that animals are influenced by the different frequencies of the spectrum, that is, they have a color sense. Finsen showed that earwigs, wood-lice and earthworms are very sensitive to the short waved frequencies—blue violet—while Gruber, whose experiments have been quoted, showed the same for the earthworm, even blind ones like the triton, being extremely sensitive to this part of the spectrum, seeking refuge either in darkness or in the long and slow waved frequencies of the red, as opportunity offered. The preference for blue violet by butterflies was experimentally shown by Finsen, and is a matter of common observation to the student of nature.

It has been, therefore, very completely demonstrated that the shorter and higher frequencies are much more strongly phototaxic than the longer and slower. The latter, if not present to too great a degree of intensity, produce the same effect as darkness. The phenomena are not always uncomplicated. They are influenced by the supply of oxygen. In the presence of sufficient oxygen the stimulus of light energy is ineffective in *Paramœcium bursaria* and the obverse when the supply is insufficient. Temperature also influences the phenomena. For example, phototaxic phenomena only appear in some instances if the temperature is raised at the same time. The phenomena are dependent upon the intensity of light, many animals reacting only to changes or to fluctuations in its intensity.

Jacques Loeb<sup>1</sup> in a series of very carefully-conducted experiments on nearly 100 varieties of animals, including caterpillars, butterflies, plant lice, ants, fly larvæ, the larvæ of beetles, various hybrids, etc., demonstrated a

---

<sup>1</sup>Der Heliotropismus der Thiere und seine Uebereinstimmung mit dem Heliotropismus der Pflanzen, Würzburg, 1890.

heliotropic action on the part of animals which agrees with and conforms to that observed by Sachs for plants.

The following phenomena were exhibited in Loeb's experiments when certain animals were exposed to white light or to blue and violet light from a single light source: (1) They arranged themselves with their long axis parallel with the rays of light; that is so that the rays fell at equal angles on symmetrical areas of the body. (2) The animals if positively heliotropic moved in the direction of the rays until as near as possible to the source of light, and remained there as long as the light did not fall below a minimum intensity, even though in so doing they followed from a lighter to a darker place. Negatively heliotropic animals obeyed the same law, but moved as far as possible from the source of light.

All factors entering into the experiments, temperature, oxygen supply, geotropism and contact irritability, which might influence the movements of the animals, were carefully controlled by Loeb in his work.

His experiments covered headless animals and those having no associating cerebral organs, and he succeeded in making certain animals positively or negatively heliotropic at will. In this way he demonstrated that the movements were not due to a subjective sense or intuition, but to direct stimulation of the muscles by the more refrangible or the blue and violet frequencies. The stimulation was the greater, the more nearly the angle at which the light struck the surface approached a right angle; hence, orientation of the animal in the direction of the light took place before the movement to or from the source of the light.

These experiments conclusively point to a directly stimulating effect upon animal cells by the visible chemical frequencies of light, i.e., the blue and violet. There can be no question but that the stimulation results from a chemical change. By the impingement of these frequencies upon the skin, penetrating as they do to considerable depth, they are no doubt absorbed by the blood.

Chemical Rays Promoters of Energy.—In conclusion Finsen says that “all this demonstrates the biological importance of the chemical rays, which are veritable promoters of life and energy.”

Raphael Dubois<sup>1</sup> has shown that in the case of *Proteus Anguineus*, which lives in the grotto of Adelsberg, the entire skin possesses the property of being excited by the luminous rays.

The Action of Light Energy in the Stimulation of Unstriped Muscular Fibre.—This has been the subject of research and experiment and it was shown by Arnold<sup>2</sup> and Steinach<sup>3</sup> that the incidence of light without heat causes contraction of the pupils in the excised eyes of amphibians and fishes. The sphincter of the iris, which narrows the pupil by its contraction, is composed of smooth muscular fibers containing a brown pigment. Even the iris of the eel when cut out and placed in normal saline solution contracts to light, the green and blue frequencies being the most active. This action is independent of the central nerve system and takes place even though the retina has been removed. The evidence points conclusively to a direct action upon the smooth muscular fiber, i.e., upon the cellular elements. The importance of light as an excitant to the nervous system is not minimized by ascribing a place to the direct action of this agent upon cellular elements.

Other investigators in this field are Brown-Sequard, Heinrich Müller,<sup>4</sup> Reinhardt and Budge.

The phenomenon is regarded by Brown-Sequard as direct muscle irritation by light. For a period of 30 hours after death Harless<sup>5</sup> observed upon human corpses

---

<sup>1</sup>Sur la perception des radiations lumineuses par la peau, chez les Protées aveugles des grottes de la Carniole. C. R. Acad. des Sc., t. CX., 1890, p. 160.

<sup>2</sup>Landois and Stirling.

<sup>3</sup>Untersuchungen zur vergleichenden Physiologie der Iris, in Pflüger's Archives, Vol. LIL., 1892.

<sup>4</sup>Landois and Stirling.

<sup>5</sup>Abhdlgn. d. bayr. Akad., 1848, v. p. 490. Quoted by Freund.

distinct contraction of the pupil of the eye upon exposure to light as compared with that of the closed eye.

Action of Light upon the Skin of Animals—Pigmentation.—Under this head a series of phenomena is to be observed which should be interpreted as phenomena of defence against the action of light, especially against that part of the spectrum of such intense chemical activity. In this part of the spectrum is to be found a source of possible danger to the living organism.

Rôle of Light in the Production of Pigment.—It is of common occurrence that animals whose skins present a diversity of coloring the darkest part is always the dorsal surface of the animal, or the part most exposed to light. In the horse, for example, the abdomen is often white while the back is brown, bay or black. In the case of flat fish but one surface is colored, and that which is exposed to light. Cunningham<sup>1</sup> proved by his experiments that light was the cause of this pigmentation. The well-known fact that many polar animals have a white robe in winter and colored in summer, referred to in this connection by Finsen, is another manifestation of the same phenomenon.

As showing this relation, the experiments of Packard<sup>2</sup> upon fauna of the caverns of America and those of Viré<sup>3</sup> upon the subterranean fauna of France, may be cited. Viré's studies were made upon the *Gammarus puteanus*, which in the light has an intense gray-green coloration. These cavernical species when placed in catacombs or subterranean passages were partially decolorized in the eleventh month and completely depigmented in the twentieth month by the fusion in all parts of the white points which first appeared in a diffuse manner upon the bodies of the animals.

The inverse action or regeneration of the pigment was obtained by Viré's experiments upon the *niphargus putea-*

---

<sup>1</sup>Quoted by Leredde and Pautrier.

<sup>2</sup>Ibid.

<sup>3</sup>Thèse, Paris, 1900, and C. R. du XIII., Congrès Internat. de Paris, d'Anatomie Comparée, p. 3.

nus which naturally is white. Upon transportation to the light, these animals toward the second month presented a blackish-green mottling of the integument, soon deepening in confluent spots, resulting in uniformly coloring the animal a greenish brown.

Böhn<sup>1</sup> in a study of the evolution of pigment concluded that "in many cases the molecular constitution of pigment can be changed directly by the luminous waves of different lengths." "Until now, a purely alimentary origin had been attributed to the substances which color so variously the pigment of the caterpillar."<sup>2</sup>

Protective Rôle of Pigment against Light.—Of this action the chameleon is a noticeable example. The Vienna physiologist Brücke,<sup>3</sup> 50 years since demonstrated the color scale through which the chameleon would pass on changing from light to darkness.

The chameleon has in the depths of its integument large pigmented cells, or chromatophores, which are particularly mobile. In the dark these rest in the depths. Under the influence of light, the color changes from a gray to almost a black, illustrating their ability to migrate from the depths to the surface and again to the depths.

Brücke showed that the movement of the chromatophores is dependent upon the central nervous system. Darkness acts on the skin of the chameleon as a stimulant, while daylight, even sunshine, reduces the pigment cells to a passive state. When the chameleon is brought into the sunlight it becomes dark by projecting the elongations of the pigment cells to the surface of the body. When they are taken into the dark the animal becomes pale in color because of the drawing back of the dark elongations of its pigment cells, so that they are covered by the light-colored pigment in the upper layers of the cuticle.

<sup>1</sup>L'Evolution du pigment, Paris, Naud, 1901.

<sup>2</sup>Leredde and Pautrier.

<sup>3</sup>Untersuchungen über den Farbenwechsel des Chameleons. Bericht der mathemat. Naturwissenschaftl. Klasse D. K. Akad. der Wissenschaft. Wien, 1852, IV.

Paul Bert<sup>1</sup> carried the experiment still further and exposed one-half the chameleon's body to the red and the other to the blue frequencies; under the former the skin remained light, under the latter it changed to dark. This subject was also studied by Krukemberg.<sup>2</sup>

From the varying behavior of chromatophores under irritation, as strychnine poisoning, rubbing with turpentine, strokes of a magnetic electro-motor and when paralyzed by cutting through the nerves, it is clear that the condition in which the cells extend their processes is the passive condition of rest, and the condition in which they draw in the processes is the active one of irritability.<sup>3</sup> This action of light upon the skin is local. This was demonstrated by Brücke, who placed a band of tinfoil around a chameleon and then placed the creature in the sun. There was as a result a light-colored strip under the tinfoil, while the rest of the body was dark. He further proved that this action was due to light—not heat.

It has been proven with other animals as well as the chameleon that this protoplasmic movement of the chromatophores under the influence of light takes place through the central nervous system.

The experiments of Ehrmann who observed in frogs the direct passage of nerve filaments into the pigment cells, made it probable that the chromatophores are connected with the central nerve organ. Pouchit<sup>4</sup> demonstrated that fishes, turbot for example, changed color under the influence of light. Turbot in whom the sympathetic nerve had been severed became dark in that part of the body in which the nerves had their origin behind the incision. Blinded fishes became dark in color through the spreading out of the pigment cells.

It is surmised by Brücke that there is a reflex action start-

---

<sup>1</sup>Influence de la lumière sur les êtres vivants. Rev. sc. 1878, 42.

<sup>2</sup>Quoted by Leredde and Pautrier.

<sup>3</sup>Freund.

<sup>4</sup>Acad. des Sc. 1871.

ing from the visual nerve, and that a stimulus of the optic nerve passes on to the central organ, a stimulus which causes the chromatophores to contract; so that when the stimulus is wanting they permanently cover a larger space.

The color of frogs and the sheaf fish is also dependent upon light according to Wittich<sup>1</sup> and E. Du Bois Reymond.<sup>2</sup> These animals were black in the dark and became light colored again under the influence of light. Exner drew attention to the movements of pigment in the eyes of insects as a result of light.

The behavior of these animal organisms with regard to light is perfectly intelligible when it is considered that pigment is a natural protection against light. This is clearly shown in the study of the action of light upon the skin. The following hypothesis as advanced by Finsen as to the phenomena of the skin against light energy, seems rational to the author, viz., that the pigment formed absorbs the light rays, utilizing their energy in transforming them into favorable chemical actions. This will be considered more at length in the study of pigmentation of the skin.

Action of Light upon the Vital Activity of Animals.—Under this group of phenomena is the action of light upon respiration, upon assimilation measured by loss of weight, and differences presented by animals raised in the light and in darkness from the point of view of alimentation, weight and blood.

Changes of Form in the Contractile Pigment Cells.—It is a well-known fact that changes of light cause changes of form in the contractile pigment cells of many fishes, amphibia and reptiles. In this way there are produced changes of color in the animal. For example, the black pigmented cell of the frog's skin, which in the dark have widespreading ramifications, under the influence of a bright light, grad-

---

<sup>1</sup>Mueller's Archives, 1854.

<sup>2</sup>Untersuch. zur Naturlehre des Menschen u. der Thiere. von Moleschott I. 1858, Bd. V.

ually contract into little balls, making the skin appear much lighter in color.

Influence of Light upon the Respiratory Chemism.—From the observation upon this function in relation to light it was concluded by early observers that light appears to augment the activity of the respiratory chemism, and that the power so to act belongs to the chemical end of the spectrum.

Differences of Weight Presented by Animals in Light and Darkness.—This was studied by Bidder and Schmidt,<sup>1</sup> who, in their experiments upon a young cat, observed that the loss of weight was greater in the light than in darkness. Fubini<sup>2</sup> arrived at the same conclusion.

Yung<sup>3</sup> in his investigations made upon tadpoles deprived of nourishment, observed that they died more rapidly under the influence of the chemical part of the spectrum than under that of any other light. From these experiments it appeared that the blue and violet light energy caused a more rapid consumption of the reserve material.

Influence of Light upon Assimilation and Disassimilation.—Borissoff's experiments contradicted those of the observers which have just been quoted.

They were made upon four young dogs of the same weight, same color, and for whom all the conditions of nourishment and aëration were equal. Two of the dogs were placed in obscurity and two in light.

The dogs kept in the light ate more than the others, and after having a less weight during the first week than that of dogs kept in the dark, they weighed at the end of a month 220 grammes more than the latter. The same experiment repeated with rabbits gave the same result. Light then acts

<sup>1</sup>Verdauungssäfte und der Stoffwechsel. Leipzig, 1852. 317.

<sup>2</sup>Ueber den Einfluss der Lichtes auf das Körpergewicht der Thiere. Untersuchungen zur Naturlehre von Moleschott, 1876. Bd. XI. 5. 488.

<sup>3</sup>C. R. Acad. des. Sc. t. LXXXVII. et Arch. de Zool. expér., 1878, t. VII., 2.



as an excitant for the organism. Borissoff<sup>1</sup> admits that the changes under the influence of this stimulus are more actively effected, i.e., tissue change goes on more rapidly, but that at the same time the nutritive materials are accumulated and fixed with more facility.

Action upon the Blood.—According to Borissoff, who examined the blood of these animals, there was no influence upon the formation or the number of the red blood cells or of the leucocytes, nor upon the rate of hæmoglobin.

The Action of Light Energy upon Blood Cells.—Uskoff<sup>2</sup> also made a study of the protoplasm of blood cells. The white corpuscles of frogs' blood showed more and longer processes in red light than in violet. Under the influence of the red frequencies they were more spread out for the most part in the form of hardly visible discs.

On the other hand Hermann<sup>3</sup> is authority for the statement that leucocytes are not sensitive to light while red corpuscles show distinct changes of shape.

It was observed by Finsen<sup>4</sup> that the red corpuscles in the blood of tadpoles changed shape under the influence of sunlight; they contracted and became rounder.

Hammer<sup>5</sup> is authority for the statement that there is no direct action of light upon the blood corpuscles, but that the effect is due to the establishment of a motion in certain nervous elements of the skin in connection with pigment cells by the action of the ultra-violet frequencies, and that secondarily this motion leads to hyperæmia, inflammation and pigmentation. His experiments are of the greatest interest, and to the author's mind only tend to prove that the action of light is primarily upon the blood itself. They were made on tadpoles, salamander eggs, earthworms, etc., for the purpose of studying not only the action of light but

<sup>1</sup>Quoted in Romme. Principles of Photothérapie, Presse Médicale, Sept. 21, 1901.

<sup>2</sup>Centralblatt f. d. Med. Wissensch. 1879 No. 25.

<sup>3</sup>Quoted by Strebel, p. 6, and by Freund, p. 412.

<sup>4</sup>Über die Bedeutung d. chem. Strahlen, Leipzig, 1879.

<sup>5</sup>Auerbach: Centralblatt für die Wissenschaft, XIX., p. 1.

the relationship between the motility of cells and monochromatic light, and demonstrated that light provoked movements in the fœtus, and that this action must be attributed to the violet frequencies.

This effect on fœtal life seems but additional proof of the action of these frequencies upon the blood, for no more intimate relationship exists between the parent and fœtus than through the medium of the placental circulation. It is only necessary to recall how quickly the red blood corpuscle is stimulated to increased function by the action of light energy to appreciate that it is not necessary to explain its effect on fœtal life by the action upon the peripheral nerve endings.

If the action is primarily upon the nervous elements of the skin, the same effect should be obtained in lupus vulgaris and syphilitic lesions, for example, by simply directing the light energies upon the part, without compression. To secure results in these and similar conditions, however, compression is necessary, thereby securing the dehæmatization requisite for a direct action upon the tissues. In both the pathologies mentioned, the crying need is for blood rich in oxygenating power; in the one to combat the micro-organisms primarily, and in the other to actively increase oxidation.

The Action of Light Energy upon the Eye.—It is not only in the skin, however, that important changes are established by the action of light energy, but in the eye as well. Since the advent of electric lighting, there have been noted by different observers a variety of effects from a simple conjunctival irritation with tired eyes to very severe ocular disturbances. According to Ogneff,<sup>1</sup> from the prolonged action of light energy of great intensity, in which the violet and ultra-violet frequencies preponderate, there is produced a necrosis in the cells of the cornea in the case of rabbits, pigeons and frogs. This necrosis of the cells of the cornea

---

<sup>1</sup>Untersuch. d. physiol. Institut, Heidelb., Vol. I., u. ff. Quoted by Freund.

is produced by amitotic nuclear changes; from a brief exposure mitosis only results. He found the other parts of the eye, the lens and the vitreous humor, were not at all affected, the retina only slightly. This experimenter was of the opinion that he guarded against any action of the thermal frequencies in his experiments.

The red coloring matter, or visual purple, "rhodopsin" which was proved by Boll<sup>1</sup> to be present in the outermost portion of the rods during life is bleached by the action of light upon the retina. This bleaching takes place during daylight, but the coloring returns when the eye is placed in darkness. Kühne<sup>2</sup> showed that by illuminating the retina, actual pictures, as, for example, the image of a window, could be produced on the retina of either living or dead frogs and rabbits, as by a photographic process, but they gradually disappeared.

By the use of a 4% solution of alum Ewald and Kühne fixed a sharp picture or optogram in a rabbit's eye dilated with atropin, at a distance of 24 cm. from the eyes.

Visual purple, or rhodopsin, withstands the action of all oxidizing reagents; zinc chlorid, acetic acid, and corrosive sublimate change it into a yellow substance, but it becomes white only through the action of light. The obscure or dark thermal frequencies are without effect, while it is decomposed above a temperature of 52°C. It is doubtful just how far this action of light on the visual purple affects the power of sight.

Vision cannot be explained by the formation of optograms by the visual purple, for it is absent from the cones, and the cones are only present in the fovea centralis.

It is the rods and cones which are endowed with what Johannes Müller terms specific energy, that is, they alone are set into activity by the swing of the oscillating corpuscles of light energy in such a way as to produce those impulses

---

<sup>1</sup>Landois and Stirling, Text-book of Human Physiology, 4th edition, p. 942.

<sup>2</sup>Landois and Stirling, 4th edition, pp. 980-981.

which result in vision. Light allowed to act upon the retina for a long time, and especially if it be intense, causes fatigue of the retina, which begins sooner in the centre than in the periphery of the organ. This retinal fatigue comes on rapidly at first, but develops more slowly subsequently.

It has been demonstrated by Kühne<sup>1</sup> that the nature and the amount of light influenced the condition of the hair-like processes sent down between the rods and cones, and also influenced the formation of pigment granules of the pigmentary cells of the retina.

In a frog kept for several hours in the darkness the protoplasm of these pigment cells is retracted, and the pigment granules lie chiefly in the body of the cell and in the process near the cell. In a frog kept in bright daylight, the processes loaded with pigment penetrate downwards between the rods and cones as far as the external limiting membrane. A retina that has been kept in the dark changes its electrical conditions when light suddenly falls upon it; the electrical current which passes normally from the retina to the brain is made stronger.

The maximum of stimulation for the eye accustomed to darkness is found in yellowish-green close to the thallium line. On the other hand the eye adapted to the light reacts most to the yellow D-line of the spectrum.

It was proved by Engelmann that frogs from whose eyes light was artificially excluded reacted with contraction of the interior cones of the retina upon exposure of the skin of the back to light energy. In this fact is to be found the proof that the stimulus of the light energy reaches the brain by a centripetal course, and is able thence to induce motor phenomena.

When the brain is removed, it has been shown by Buedingen that this reflex action does not take place. From this the conclusion must be reached that this transformation of the light energy stimulus takes place within the brain itself.

---

<sup>1</sup>Landois and Stirling.

Stimulus of the visual areas may produce spectra. This phenomenon cannot be produced at will by all persons. Cardanus (1550), Goethe, Nicolai, and Johannes Müller could produce spectra at will.<sup>1</sup>

It has been shown by von Helmholtz,<sup>2</sup> Bence Jones,<sup>3</sup> Dupré and John Tyndall that the lens possesses the power of fluorescence to a high degree.

Von Helmholtz, after cutting out all the spectrum, including the violet rays, succeeded in seeing the ultra-violet rays, which had a feeble grayish blue color. The heat rays in the colored part of the spectrum are transmitted by the media of the eye in the same way as through water. The existence of the ultra-violet frequencies is best ascertained by the phenomenon of fluorescence. As the media of the eye themselves exhibit fluorescence (von Helmholtz), they must increase the power of the retina to distinguish these rays. According to Brücke, ultra-violet frequencies are not largely absorbed by the eye.

Tyndall found upon bringing his eye into a violet ray that he noticed a bluish white glimmer filling the space in front of him. This glimmer comes from the fluorescent light in the eye itself. The crystalline hue of the eye when looked at from without lights up brightly at the same time." It seems very probable that this peculiarity of the lens common also to the vitreous body is the explanation of the ability on the part of some persons to perceive sensations of light under the influence of Roentgen and Becquerel rays. It is not impossible, as suggested by Freund, that electric stimuli of the retina and the optic nerve may have something to do with it.

---

<sup>1</sup>Landois and Stirling, Text-book on Human Physiology.

<sup>2</sup>Ibid.

<sup>3</sup>Medical Times and Gazette, London, Aug., 1866, pp. 163-167.

## CHAPTER VII.

The Physical Effects and Biological Action of Light Energy. Skin, Circulation, Nervous System, Metabolism.

### **The Physical Action of Light Energy.**

When a wave of any kind strikes an obstacle that is much smaller than the wave length, the wave gets by the obstacle without much difficulty. For example, an ocean wave of 60 feet in length is not troubled by a stake one foot in diameter, by reason of the fact that 60 such stakes would be required to make a wave length. The stake would throw no shadow behind it upon the wave. When, however, the wave length is of the same order of magnitude as the obstacle, the wave does not get by unobstructed, but on the contrary is broken up, reflected or jostled out of existence by the obstacle. A one-foot stake at the mouth of an ocean river would stop waves of 3 or 4 feet in length, or cause a shadow beyond. When light of ordinary visible wave length strikes a molecule which is a very minute obstacle, the wave length is long by comparison with the molecule and goes smoothly on with but little absorption, or else is smoothly reflected with but little absorption; but when ultra-violet light is used, the wave length is sufficiently short to make the molecule, or molecule groups, interfere with and break up the waves, more or less. This breaking up of waves involves imparting energy to the molecules and possibly the disruption of molecules with that energy. The higher the frequency of the oscillating light corpuscles the more likely this is to occur. Groups of molecules are much

more likely to be affected than individual molecules, just as a disruptive action would be more marked from the impingement of waves of suitable length upon a group of persons than upon a single individual, that is, in the jostling and general shaking up to which they would be subjected. The individual might be passed by as the individual molecule by the longer wave lengths. It is possible that there may be some particular sympathetic resonance between atoms and light frequencies, as, for example, between oxygen atoms and ultra-violet light frequencies.

The following theories and facts are generally accepted throughout the scientific world to-day, and help to elucidate the problem of the action of vibratory energy. All matter, whether organic or inorganic, is in a state of continual motion as regards its molecular or atomic structure. As we go up or down the scale this motion increases or decreases as we go up or down the temperature scale, until it theoretically ceases at absolute zero. The motion is vibratory and depends, so far as its changes are concerned, upon the vibrations in the radiant energy acting upon the body of which the molecules are constituents. When the vibration is of sufficiently high frequency, the molecules break down into simpler forms, and the more complex the molecule, the lower is the frequency of vibration necessary to produce this result. In the ethereal vibration of radiant energy, the temperature of the body is raised. This Bean<sup>1</sup> regards as proof that one form, at least, of molecular vibration is induced by an ethereal vibration. The physician's conception of light should not be from the point of optics and concern the visual frequencies only, i.e., from and including the red, to and including the violet, but must embrace the invisible part of the spectrum also. That mysterious region known as the ultra-violet is of equal interest to the physicist and physician, as is also the invisible region below the red.

---

<sup>1</sup>William H. Bean, Ph.D.: A theory as to the Roentgen Ray Action upon Malignant Neoplasms. *Advanced Therapeutics*, May, 1902.

According to Langley, the energy of the spectrum is contained as follows :

Ultra-violet region .....	1/100
Visible .....	19/100
Thermal beyond the red .....	80/100

But as the visible contains much heat, the energy called light is after all very small. It is an established scientific fact that many chemical actions will not take place until a certain temperature is reached, which means the attainment of a certain molecular vibration period. Others again may be brought about by exposure to light, which may or may not change the temperature, but which manifestly must have influenced the molecular vibrations. This action is shown to vary with the different parts of the spectrum. Photobiology has established, for example, a bactericidal action for the middle third of the ultra-violet region, the ability to excite tissue reaction also to the ultra-violet, but the exact locality not determined; a quieting action upon the nervous system to the blue frequencies and apparently an increase of muscular power under their influence. There is also apparently an exciting or stimulating action upon the nervous system from the frequencies of the red region. These varying effects are due to the varying wave lengths or the varying frequencies of vibration. From the action of a complex of all of the frequencies, there is an influence upon molecular activity. In considering the phenomena of the vibrations of sound and the laws governing it, it is well known that to produce a musical note, it is necessary either to strike the body capable of giving it out, or to have it placed where it may receive the influence of another vibrating body. For this latter effect, however, the vibrating body must be of the same pitch or an even multiple of it, and the vigor of the response depends for one factor upon the approach of that multiple to unity.

Bean advanced the theory that a restorative change might be established in a pathologic cell-like cancer cell, for example, by which instead of being destroyed, its character



may become so altered that it becomes again a normal cell. Such a change he attributed to the action of the Roentgen ray. A single X ray impulse is in every respect an ultra-violet light frequency, but there the similarity ends, for the oscillating corpuscles of ultra-violet light are rhythmic and continuous, while the X ray is a discontinuous, infrequent and solitary pulse. The proper atomic motion of a cell, for example, should be stimulated by being in synchronism with an ethereal vibration, whose period of vibration is the same or a multiple of it. In this way, not only groups of molecules but single molecules should be affected. In the longer and slower frequencies, as represented by visible light, are unquestionably to be found the periods of vibrational activity necessary to the maintenance of the living organism in a condition of normal health and function, but when it comes to be a question of diseased processes, a tubercular gland, a lupus patch, an organized exudate, associated with beginning degenerative changes, a sepsis, a syphilitic lesion, it seems necessary, judging from a knowledge of physical laws and physiologic action, as well as clinical results, to have the periods of vibrational activity not only that of groups of molecules, but also in sympathetic resonance with the periods of individual molecules or atoms.

The author believes that the action of condensed light, of which ultra-violet frequencies are active constituents, in diseases characterized by deficient oxidation, the sub-catabolic diseases of Wakefield, is to be accounted for on physical grounds by the fact that there is a sympathetic resonance between the vibrational activity of the oxygen of the blood and the periods of ultra-violet frequencies. It has been established by Cornu that the ultra-violet frequencies from the sun are absorbed not by the varying constituents of the atmosphere, such as the watery vapor, but essentially by the oxygen and the nitrogen of the air. The swing of the oscillating corpuscles of the penetrant chemical frequencies have either the same periodicity or rate of vibrational activity as an oxygen atom, or are a near multiple of the nor-

mal atomic action. In other words they are in sympathetic resonance. It does not seem to admit of question but that the essential principle of chemical action and vital activity, viz., motion, molecular or atomic, is one and the same thing. They blend almost imperceptibly, the one into the other, at a very great many points. Granted, as the author has assumed, that the molecules of a body, either inorganic, organic or protoplasmic, have a motion dependent upon ethereal vibration, and that the atomic constituents of the molecules of these substances or bodies have a rate of vibrational activity or motion peculiar to the molecule to which they belong, then it follows that this rate of vibrational activity or atomic motion must be influenced by the right kind of vibrational activity of the ether. The range of this vibrational activity must be compatible with the integrity of the molecule itself. The breaking up of the higher frequency of the oscillating light corpuscles, as they encounter the swing of the oscillating atoms or molecules, results in an impartation of energy to the molecule, or there may be a disruption of the molecule as the result of that impartation of energy. It seems very probable that both physical actions take place from the administration of concentrated and intensely chemically active light frequencies in a process such as lupus vulgaris, for example.

In the ability of the ethereal vibrations of radiant energy, light and heat, to establish responsive or synchronous motion in the molecule of a given cell, motion peculiar to that of the molecule in question, must be found the rationale of their action. The response of a given atom or molecule may be only sufficient to secure the proper maintenance of normal equilibrium, as under natural conditions of exposure to radiant energy. But when intense chemically active light energy from near its source is localized and concentrated for prolonged periods of time over a dehæmatized region or lesion, something more happens than the normal responsive molecular motion of the molecules or groups of molecules, as is evidenced by the nature of the regressive and productive

tissue changes as well as clinical results. If a cell is not irreparably damaged, then by the return of the normal atomic motion of its constituent, it becomes the seat of renewed life and activity. If the converse is true, the molecular agitation resulting from the action of the very short and high frequency light vibrations must still result in a stimulating action upon the surrounding undegenerated tissue tending to the absorption of the débris of degenerated cells. In the case of bacterial growth or abnormal cells, they are so agitated and worried by the jostling activity of the light corpuscles as to be compelled to deliver up their energy, and eventually are put out of commission, as it were. To this end successive applications are required as there is no question of immediate destruction of bacilli or correction of abnormal cell activity.

It was pointed out by Bean that the difference as regards activity is comparatively great between a cancer cell and an epithelial cell, while as regards constitution, comparatively slight, and that the tumor cell represents a tendency to return to a more primitive form, rather than to an advance in the developmental scale. In this same connection he states that a similar suggestion might be seen in the chemical phenomenon of physical isomerism. He reasons, therefore, that the atomic movements of one are not greatly different from those of the other, and that an ethereal vibration favorable to the one would be corrective toward the other, providing it were strong enough to affect it at all, which is not the case with ordinary light and heat in malignant processes. The ability of a given energy, the X ray or the higher frequencies of light, for example, to produce a return to the proper atomic motion of a cell, providing it had not wholly departed from it, is the physical explanation put forward by Bean for the effects produced by the X ray. In his opinion their action appears to be a corrective and not a destructive one. If the theory advanced by Bean is correct, their action by reason of their physical characteristics is that of a sudden release of energy, which starts into

activity the diseased cell or cells which have departed almost wholly from their proper atomic motion, just as a sudden noise arouses the quiet sleeper.

The frequencies of light energy, however, have not only the same period of vibrational activity, or a near multiple of the vibrational activity of the atoms of cells, but also a rhythmic flow which renders them a safer molecular stimulant than the X ray, and one which should preferably be chosen in all conditions other than malignant. In some of the milder manifestations of malignant disease, the more superficial epitheliomas, for example, the departure from normal cell life, or normal atomic motion is not so great but that the periods of the ethereal vibrations known as light can favorably affect them.

There must be a different period of atomic motion for a giant-celled sarcoma, for example, to that of a degenerating cell, requiring, so to speak, a more sudden and violent expenditure of energy than the latter. Nothing is to be gained by knocking a man down when a soft word will answer the purpose. Similarly, a sudden and violent expenditure of energy, as of the vibrational activity of the X ray, is to be condemned when the synchronous vibration or sympathetic resonance of light frequencies will suffice. The former may and does produce severe dermatitis with necrosis, and an effect even upon deeper structures. This is unquestionably due to the violent action of X ray impulses. The poorer the vitality or body condition the less is the power of resistance, and the greater the damage. Chemical light frequencies also produce a dermatitis, but one from which recovery is easy. These are not powerful enough to produce responsive atomic vibration in the cancer cells, nor for that matter is the X ray, as we know and use it, in the more profound and deep-seated lesions of this character.

As yet it is impossible to say just what periodicity of vibrational activity or frequency of light vibrations is required to influence the periods of vibrational activity of the cells of different kinds of tissue.

That this is largely theoretical is true, but from a knowledge of physical laws, it is a theory that seems very near the truth. It is the high and short frequencies, those of great chemical activity, which influence so profoundly cell action. In diseased processes other than malignant there may be no question of a departure from normal atomic motion on the part of the atoms of a cell, only a more or less profound diminution of it.

The atom which has ceased to swing or vibrate, as it were, is hopelessly extinguished, but just so long as there remains the slightest atomic motion, it is possible, by the action of an ethereal vibration of the right period, to stimulate it into renewed activity until once more it enters into its normal motion. If waves interfere (and waves represent definite periods of vibrational activity) by odd multiples of half wave lengths, they destroy each other, or if they hit matter in these odd phases they destroy themselves, but if they strike matter in even phases they do an incredible amount of work. They sustain every activity on earth, and alone keep up life.<sup>1</sup>

Were light frequencies destructive they would destroy not simply inhibit bacterial growths. On bacteria outside of the living body they do possess a destructive power which indicates only that in the living organism the conditions of atomic vibration around them are of such a nature as to prevent the immediate loss of their own atomic motion. It seems rational to conclude from the nature of the physical action of the short and high frequencies of light, i.e., their jostling activity by which they agitate and shake up small things like atoms, involving also a chemical change, that the micro-organisms would lose some of their power or virulence, and that successive applications should ultimately deprive them of their energy, increasing at the same time the physiologic resistance of the organism. Bean reasons that with the X ray they would either take on an increased

---

<sup>1</sup>Larkin: Radiant Energy.

growth or not be affected at all, and that the former would indicate a responsive atomic motion and the latter simply a failure to respond.

To the author's mind an inhibitory action seems more likely to ensue, in so far as bacteria are concerned. By inhibition is understood a reduced or arrested nutrition. This is a result of the chemical change brought about by an undue atomic motion or agitation.

The superficial cells of an ulcerating tumor do not, under these forms of vibrational activity, show any evidence of a destructive action: on the contrary, they present an appearance of increased vitality. In developing his theory Bean states that probably only the younger cells are favorably influenced by the action of the X ray, and that the mature tumor cells have probably so far departed from their normal condition, i.e., atomic motion, as to be uninfluenced by an expenditure of energy, such as the X ray, that any changes to which they are subject will depend for the most part on the nutrition they receive. If the younger cells return to normal periods of vibration, and the older cells undergo nutritional changes, a shrinking or atrophy of the tumor mass will follow which is very often the case, a firm but smaller mass remaining at the site of the tumor. When there is a complete disappearance of the mass, he believes it to be due to a phagocytosis, in connection with the atrophy, a condition which at the time of his exposition of the subject he was attempting to determine by microscopical studies.

There can be no question but that there is a similar physical action of the chemical frequencies of light, since the physiological action and the nature of tissue changes established by its use are of the same order. But there is lacking the harsher effect, due in all probability to the more sudden and consequently energetic stimulus to atomic motion from the irregular and infrequent X ray impulses. The constant regular vibration of steam cars, for example, is more tolerable than the jerking and jarring produced by

the frequent starting and stopping of the street car. Different effects follow, and while the latter might be serviceable to a sluggish, hepatic circulation, for example, it could not be advised for an essential neurasthenia. It is by reason of this difference in physical action that the frequencies of light energy are of no avail in malignant processes save in the more superficial conditions of comparatively recent standing. In recent conditions, the departure from the normal atomic motion must be very slight, hence the brilliant results obtained. In this way then a restorative change may be established in a pathologic cell; not in destroying, but in altering its character by restoring it to a normal period of vibration or atomic motion. This may follow the use of other forms of energy than light, or, as instanced, the X ray. It may and unquestionably does follow the exhibition internally of some forms of medication of which strychnia is a notable example. The various frequencies of light vibrations produce without doubt varying differences in effect upon cells.

The analgesia, which is produced by the concentrated, visible chemical frequencies of light, may be induced by a continuous, harmonious vibration, which, judging from effect, has served to tetanize as it were, and exhaust the motility of peripheral nerve elements.

From the physical properties of light energy and its physical action upon a body endowed with a vito-chemical constitution, as is the living organism, follow chemical, osmotic, and molecular changes or physiological action. So far as the chemical end of the spectrum is concerned, this physical action seems a rational one. But for that matter all the visible frequencies are chemical as well as the invisible beyond the violet, and the same is true at the other end of the spectrum. It is only that certain frequencies, i.e., from the blue and above, are more intensely active in this way in relation to the living organism, at least so far as known. In normal conditions of the living organism, the higher chemical frequencies as used therapeutically in con-

centrated light energy, are not essential but only active as they exist in diffused sunlight. When physical conditions, as they relate to light and atmosphere, render them intensely active, and when the conditions of the living organism render it especially vulnerable, i.e., in conditions of more or less depressed vitality, untoward results follow. This is forcibly shown in insolation or sunstroke. There is some evidence also that in prolonged unbroken periods of sunshine, with atmospheric conditions favorable to more than normal diffusion of the chemical frequencies, i.e., less active absorption before reaching the earth's surface, that nerve and mental states, where predisposition exists, are profoundly and unfavorably influenced. In an experience extending over 10 years among the insane, it was a matter of common observation, that an untoward influence was exerted over the mental state of patients under these physical conditions. In addition the greater prevalence of both suicide and homicide has been noted by the author over a period of 30 years, as well as by others, during the prevalence of such physical conditions. The question arises what is the influence at work to produce such an intense excitability of the cerebral cortex or to so profoundly influence conditions of nerve depression. There must, however, be considered all of the physical conditions, not only that of radiant energy, but relative humidity and atmospheric pressure as well.

Is the cerebral cortex unduly stimulated especially in those predisposed, by the frequencies of the red end of the spectrum? Are the nerve centres unduly depressed by too profound activity of blue or chemical light? There seems enough evidence to find ground for the questions. Some time the relation of all the observed facts as to the relation of health and disease to all physical conditions will be unravelled and formulated. Whether man with his peculiar constitution, his desires and aspirations will be any better off, physically, mentally or morally, for the knowledge, is another question. Still it is true that life has been greatly



safeguarded against many conditions of disease by reason of a definite knowledge of the relation between cause and effect.

Be this as it may, the physiological action of light, and not only the need but the dependence of the human species upon it for continued existence, remains unchallenged. The theory and practice of General Pleasanton of "blue glass" fame was not without a scientific basis, building as he did his sun rooms with every eighth pane of blue. But in common with all new theories and practices, it failed of sufficiently accurate scientific knowledge and careful discrimination. To-day the unparalleled work of Finsen, as well as that of others, places us on surer ground.

Light energy causes contraction of protoplasm, and acts directly upon the blood, increasing thereby its oxygenating power. The periodicity of the vibrational activity of the higher light frequencies and their periodical relation to the vibrational activity of oxygen atoms, and also the fluorescence of the blood and of the lymph serum, furnish abundant supporting and corroborative evidence of the physical and physiological action of light energy. This is further substantiated by the intimate relation existing between the normal organism and light energy, as well as by a very considerable experimental work and clinical data.

The Decomposing Power of Light.—Tyndall showed that if a beam of solar light be sent along its axis through a wide glass tube containing a quantity of the vapor of nitrite of amyl, which prior to the entry of the beam was as invisible as air, that upon the entry of light, a cloud precipitated on the beam. This is due entirely to the waves of light which wreck the nitrite of amyl molecules, the products of decomposition forming innumerable liquid particles which constitute the cloud. Many other gases and vapors are acted upon in a similar manner. This decomposition is not produced by the frequencies of the greatest energy in the

solar light. The infra or ultra-red frequencies could be gathered up and sent through the vapor like a beam of light, but though possessing vastly greater energy than the light frequencies, they fail to produce decomposition. To effect this a suitable relation must subsist between the molecules and the electric vibrations or waves of light. The photographer fearlessly illuminates his developing room with light transmitted through red or yellow glass; but he dares not use blue glass, for blue light would decompose his chemicals.

And yet the waves of red light measured by the amount of energy they carry, are immensely more powerful than the waves of blue. Tyndall pointed out that it was misleading to term the blue rays chemical, for, as shown by Draper and others, the rays that produce the grandest chemical effects in nature, by decomposing the carbonic acid and water, which form the nutriment of plants, are not the blue ones.

When it is a matter of decomposing the salts of silver and many other compounds, the blue rays are the most effectual. These short and higher frequencies or weak waves, as termed by Tyndall, can produce effects which the longer, slower or strong waves are absolutely incapable of causing by reason of their periodic motion.

It is the accord between the vibrations of the voice and those of the strings of a piano which cause the latter to sound when singing with it. Were this accord absent the intensity of the voice might be quintupled without producing any response. But when voice and string are identical in pitch, the successive impulses add themselves together, and this addition renders them in the aggregate powerful, though individually they may be weak.

In a similar fashion the periodical strokes of the oscillating swing of the light corpuscle accumulate until the atoms upon which their tuned impulses impinge are jerked asunder and chemical decomposition ensues.<sup>1</sup>

---

<sup>1</sup>Tyndall: *New Fragments*.

### The Action of Light Energy upon the Human Organism.

The general action of light to-day rests largely upon hypothesis. From its principal action outside of the living organism and from the constitution of the latter, as well as from its known action upon plants and the lower animals, a certain amount of speculative theory is permissible. One mode of action is, however, firmly established and that is the action upon the skin. The well-known physiological action of stimuli, chemical or mechanical, in exciting either direct or reflex nerve phenomena, in relieving local congestions, influencing absorption of inflammatory products, need only be instanced to indicate that if no other tenable interpretation is offered for the action of light upon the living being, the known action upon the skin offers a rational explanation of many of the phenomena produced through this agency.

The action of light energy upon the skin, however, is scientifically established. It is certain, clear and precise and stands as a basis for future study and investigation of the action of light upon the general organism.

The Action of Light Energy upon Normal Skins.—In a previous chapter the passing and occasional reaction of the chromatophores to light radiation has been considered. This is to be distinguished from the more or less permanent pigmentation to be seen both in men and in animals and in the parts of the body exposed to the action of light. When the skin containing cells which produce melanin, a melanotic brown pigment formed only by the cells and not by the interspaces (melanoblasts), is exposed to the action of the solar light, the melanin or pigment is developed there, from the more abundant nutriment received under the stimulus of the light energy to the cells. In this way the tanning of the skin in those exposed to the constant action of the light, is produced. It may proceed to a sepia-brown coloring of considerable permanency. In those constantly exposed to the action of light it never disappears.

Pigmentation, the Skin's Protection against Light Energy.—Evidence of this is to be found in the dark, almost black coloring of peoples or races of tropical climes where they are always exposed to strong insolation. The parts of the body exposed to the action of the light are always darker. The same is true of animals. The curious fact was observed by Wedding<sup>1</sup> that light and parti-colored beasts, cattle and sheep, when fed on buckwheat if exposed to sunlight broke out in blisters. The parti-colored beasts showed the skin condition in the light parts; the dark parts remaining unaffected. Beasts kept in the dark and fed on the same food remained healthy. Wedding smeared a part of a cow with tar. As a result the eruption only appeared upon the untarred part of the skin. This is supposed by Tappeiner to be due to the fact that through this food (buckwheat) substances get into the body which are capable of fluorescence, i.e., when exposed to the action of light they absorb energy of radiation at one degree and emit it at another. This action of fluorescent stimulation is considered more in detail in the chapter devoted to that subject. Freund<sup>2</sup> in this connection reports an interesting and corroborative instance of the protective action of the pigment of the skin against light. He came by chance upon a dark complexioned man who for many years had had vitiligo patches upon the body and face. This man after a long walk over the Grosslockner glacier, developed violent inflammation (erythema) in vicinity of the white patches on the face but in those regions alone. Nowhere else was the skin affected. This protective pigmentation may be acquired deliberately as was done by Finsen,<sup>3</sup> who painted a ring around his arm with India ink and then exposed the arm for three hours to very strong light, after which the paint was removed. The skin, which at first seemed quite normal, showing only some redness at the edge

---

<sup>1</sup>Verhandlungen der Berliner Gesellschaft für Anthropologie, 1888, p. 57.

<sup>2</sup>Freund, Radiotherapy and Phototherapy, p. 420.

<sup>3</sup>Hospital student, July 5, 1893, Journal Physical Therapeutics, January 15, 1901.

of the belt, became red and inflamed all over, save in the area covered by the ink, where it was white and normal. After several days the redness disappeared and the skin became pigmented all over the area which had been red and inflamed. He then exposed the same arm to sunlight as before but without the India ink belt, with the result of the white belt becoming inflamed while the pigmented skin around it remained unaffected. The experiment is a most conclusive one, the same arm and the same skin having been subjected to the action of the solar light. Different skins react differently and a comparison to be of scientific value should be made upon the same subject. This reaction is a matter of common occurrence in individuals in those parts of the body unprotected by clothing under the influence of strong solar light. In the use of light in the treatment of skin conditions, this pigmentation serves to prevent the same absorption by the skin and reaction from the use of strongly chemical light in subsequent exposures as takes place in the first exposure. A practical point just here might be made, viz., to make a prolonged application at the first sitting in order to profoundly influence the pathological condition before nature turns her armed force of melanoblasts against further exposures. Finsen's experiment not only proves the importance of the skin pigment as a protective against light rays, but affords at the same time an explanation of the much disputed point as to the reason of the color of the negro's skin.

Action of Light Energy upon Normal Skin.—Acute lesions are thus produced due to the action of light upon the skin. These may be induced by sunlight, solar erythema or by the action of electric arc light, arc light erythema.

The Sunburn of Glaciers.—The phenomenon has been carefully described by DeLong,<sup>1</sup> Klutschack,<sup>2</sup> Nordenskiöld,<sup>3</sup>

---

<sup>1</sup>The Voyage of the Jeannette, London, 1883.

<sup>2</sup>Als Eskims unter den Eskimos. Wien, 1881.

<sup>3</sup>Den Andra Dicksonska Expeditionen till Grönland, Stockholm, 1885.

and Widmark.<sup>1</sup> After a course upon the ice of glaciers or in the midst of snows despite the very low ambient, and although not suffering from cold, tourists or explorers of mountain glaciers or of the north seas present phenomena absolutely analogous to sunburn. The condition is characterized by intense redness of the skin, by heat, smarting, a sensation of burning. This is followed by a desquamation of greater or less abundance according to the extent of the original inflammation of the skin.

Nature of Pathological Change.—The skin inflammation from a glacial burn is followed by a deep but evanescent brown coloring of the skin and differs from the normal production of pigment or tanning consequent upon the action of light. From a single exposure to intense solar or electric light there is produced by the action of the strong light a marked hyperæmia of the skin; the plasma of the blood, in which hemoglobin is dissolved, finds its way out freely through the walls of the capillaries. In a short time the hemoglobin is deposited in the interstices of the tissue as golden yellow hemosiderin. This causes the brownish-yellow color of the skin, which only disappears after this blood pigment has been absorbed, i.e., in a few weeks.<sup>2</sup> The pigment may also be developed from the red blood corpuscles directly. They may pass by diapedesis out of the walls of the blood vessels and shrivel up into pigment corpuscles.

Electric Arc Erythema.—This finds its counterpart in solar erythema or sunburn. The first observation of this action upon the skin reported was by Charcot,<sup>3</sup> who observed it in two workmen. As a source of energy a Bunsen pile of 120 elements was used. The same evening they experienced visual troubles and the next day both of them presented an erythema of the face accompanied by a feeling of discomfort and tension. This erythema, identical with sunburn, was followed by desquamation.

<sup>1</sup>Ueber den Einfluss des Lichtes auf die Haut. Hygiea. Festband, Nr. 3, 1839.

<sup>2</sup>S. Ehrmann, Wiener Med. Wochenschr. 1901, No. 30.

<sup>3</sup>Comptes Rendus Soc. de Biol., 1858.

Charcot voiced the opinion for the first time that the condition was due to the action of the more intensely chemical rays.

The Electric Sunburn of Workmen in Electric Plants.—Defontaine,<sup>1</sup> Maklakow<sup>2</sup> and Finsen<sup>3</sup> are quoted as having made observations as to the production of this phenomenon. It is of common note.

There is also produced a similar erythema in workmen exposed to the influence of electrically operated furnaces, in electric welding for example. It does not matter what the source of light energy, whether the sun, an electric arc or an electric furnace, each time that the skin is exposed to the action of the intense chemical light energy, there are produced the same lesions known as sunburn.

Phenomena of the Reaction upon the Skin from the Action of Intense Light.—The phenomena of this reaction are an increased coloring of the skin from a bright to a copper red, a swelling of the skin accompanied by a burning sensation and pain. In consequence of the proliferation of the horny layer the processes are marked. From exposure to a very powerful source of light energy, the action is much more intense. Blisters are formed, larger or smaller, with ecthymosis and even more or less deep seated necrosis of the tissues. This may, when the action has been intense, be followed by a degree of ill health. This occurs in workers about powerful electric arcs of which in several instances the author has been personally informed. After a few days, this varies with different individuals, the skin becomes less red and the pigmentation increases. The swelling diminishes, the blisters dry up, and desquamation takes place, at first in large flakes, subsequently in smaller bran-like scales. The process is similar to that of scarlet fever.

Time of Reaction.—This reaction to the action of chemical light energy does not take place immediately. In this

<sup>1</sup>Bull. de la Soc. chir de Paris, Dec., 1887.

<sup>2</sup>Arch. d'ophtalmal. IX. 97, 1889.

<sup>3</sup>Mit. aus Finsen's Med. Lys., Vogel, Leipzig, 1900.

respect it differs from the action of thermal energy. This takes place immediately but dies away quickly.

The reaction from light has a latent period, as do the Roentgen rays, but with the latter it is much longer. The length of time required for light reaction to reach its height, depends upon the intensity of the light energy. It is prolonged in proportion to the intensity of the light action and dies away slowly with desquamation and absorption of pigment.

Maklakow, Moeller and Finsen have experimented to determine the period of latency, as have more recently Leredde and Pautrier. Maklakow observed that the effect of a 15 seconds exposure to a powerful arc light (ampèrage not given) was not seen until after 10 hours. An exposure of the skin to the light energy for one minute showed distinct circumscribed hyperæsthesia after half an hour, redness appearing after 2 3-4 hours. From an exposure of the skin for  $3\frac{1}{2}$  minutes it became red in 11 minutes and portions of the skin exposed for 5 3-4 minutes reddened after 3 minutes. The experiments of Finsen and Moeller confirmed those of Maklakow.

Before the deduction of a law governing the duration of the period of latency the reader is invited to a study of the very complete experiments of Leredde and Pautrier.<sup>1</sup>

Histology of Solar Erythema.—Leredde and Pautrier made a biopsy (examination of tissue from the living subject) at the level of the skin of the shoulder upon one of their friends who had contracted in boating a severe erythema or sunburn. The biopsy was done 3 days later. Macroscopically, the skin presented only an acute erythema; the color that of a red crab. There was no œdema or effusion.

With a magnifying glass places of separation, a sort of cleavage of the epidermis, were distinguished. When slightly magnified, the epidermis under the microscope appeared almost normal in disposition and thickness. The

---

<sup>1</sup>Leredde and Pautrier, Photobiologie and Photothérapie.



corneous layer was observed exfoliated in spots. There were no lesions of importance in the derma; it appeared richer than normal in cellular elements, and there was a distention of its connective tissue bundles. With a higher magnifying power the corneous layer was observed a little raised and separated from the granular stratum. It is leaf-like and exfoliated by the superimposed layers. The granular layer is intact and formed of 2 to 3 layers of cells. No important alterations are noted in the rete mucosum. A spongy condition was noted, and the intercellular spaces appeared slightly increased. Some of the cells presented the *état cavitaire* of Leloir. In the basal layer there were noted numerous figures of karyokinesis, much more than normal. The lesions of the derma were of slight importance. There is slight œdema; the connective tissue bundles are slightly separated, the vessels present a very evident state of dilatation. A slight leucocytic infiltration, forming in spots, is observed. The connective tissue cells appear a little swollen and are a little more plainly visible than ordinarily. There is no karyokinesis observed, however.

The lesions are identical with those produced by the light energy of an electric arc, so absolutely similar that it might be supposed that the same agent had been at work.

The skin of the forearm of one of the experimenters was exposed to the action of the light energy from a Lortet and Genoud apparatus. (In this country the Victor lamp is practically the same.) It was maintained regularly at 15 ampères. Between the skin of the exposed arm and the arc itself the quartz containing water chamber intervened and the distal enclosing plate was used as a compressor. This consists of two quartz discs enclosing the water chamber, or instead of discs or plates focal lenses may be used.<sup>1</sup> The experiment was conducted under the same conditions as a treatment of a dermatosis by the energy of the electric arc would be carried out, in order to determine microscopically the mode of action, i.e., the nature of the tissue changes upon

<sup>1</sup>For description see Chap. XII.

normal skin. There was taken into account at the same time the differences which exist between the mode of reaction of the healthy and of the diseased skin.

The arc was maintained constantly at 15 ampères, the time at 17 minutes, and the distance of the compressor from the arc at 4 cm. Their examinations, "biopsies," were made from one-quarter of an hour after the exposure to a period as remote as 8 days. In this way they were able to follow the process step by step. For all the examinations the skin fragments were treated with a saturated solution of sublimate and fixed in paraffine. The sections were colored with hematin, with hematin-eosin, with hematin and with orange, and with thionin.

First Experiment.—The macroscopic observation showed only a moderate roughening of the skin. Microscopically, no important histological modification was noted. The most that could be observed was a dilatation of certain blood vessels, the lumen of which gaped when the vessels were cut transversely.

Second Experiment.—Biopsy made 2 hours after the exposure. In this section there was observed at the level of the region treated a fresh erythematous tint and a very slight œdema, with a very slight loss of epithelium at certain points.

With a low power microscope lens there appeared but slight dermic alteration, while there was considerable alteration in the epidermis, tending to end in vesiculation.

With a little higher power lens an œdema of the derma was observed slightly separating tissue bundles, and perivascular lymphatic spaces. There was also noted moderate cellular infiltration by the lymphocytes. Mast cells appeared in normal numbers. The important phenomena observed is a slight proliferation of the fixed cells, or rather a tumefaction which renders their swollen protoplasm more apparent.

These were the same lesions which were established by Leredde and Pautrier in the histology of sunburn. The

epidermic alterations are more considerable. In places there is a partial exfoliation of the corneous layer; and there are some cells that have preserved their nucleus. In the granular layer there is an almost complete disappearance of the granules. This layer is represented by one or two layers of flat cells, scarcely colorable. There is an irregular disposition of the cells of the Malpighian layer. Above all the spongoid state of Unna and the *état cavitaire* of Leloir were noted. There is a varying intensity of the spongoid state according to the points observed. In places the cells are lightly separated from one another and their filaments distended, while in other points the more abundant exudate has pressed back the cells disposed around it, representing an embryonal vesicle. Very small subcorneous bullæ are noted at certain points, formed by the cleavage of the corneous layer in its union with the mucous body. Such bullæ are filled with granules and anastomosing fibrils, which seem to be of fibrin.

The *altération cavitaire* of Leloir is observed at every stage; the clear perinuclear space is soon increased, while the exoplasm is pushed back to the periphery of the cell. Next there is observed a curious alteration. The centre of the nucleus is deeply colored, around it is an ill-defined vacuole, then the protoplasm colored a pale blue by the thionin, and the whole floating in a little vesicle. Again the protoplasm seems to have disappeared, and there is only found the nucleus and some protoplasmic granules. In other elements the nucleus is no longer colored, and there is found no more than a skeleton of it. At another place a formed but minute vesicle with some cells of Malpighi quite regularly disposed around it, presenting upon one of the sides of the vesicle a cell already partly destroyed, is observed. The nucleus of the latter surrounded with a small band of protoplasm plunges into the vesicle, and is no longer held to the wall of the latter save by 2 or 3 protoplasmic prolongations.

Résumé.—These lesions the spongoid and cavitary altera-

tions exist as well at the base of the epidermis as at the superficial part. The corneous alterations appear, generally speaking, to be a great deal more important. As a rule the Malpighian cells are more voluminous than ordinarily and appear to be soaked with serum. Although in spots the Malpighian layer presents a certain thickening, no karyokinetic phenomena are observed.

There is not noticed in connection with the lesions just described any alteration of the hair follicles. They present no indications of having been subjected to the action of light. Their epithelium is normal, and the fresh coloration by thionin is in marked contrast to that of the rest of the epidermis, which was colored poorly.

It was concluded by the experimenters that this preservation of the epidermis about these follicles is due without doubt to the accumulation of corneous substance in the utricle which protects it.

Third Experiment.—Biopsy made 4 days after exposure to the light energy. There is observed upon the point treated a brownish-red color and a sort of cleavage of the epidermis, which seems raised at certain points, without there being actual vesicles. With the microscope the lesions of the epidermis appeared very considerable while the dermic reaction was but little marked.

The Epidermic Lesions.—There were 2 very different aspects to the epidermic lesions, depending upon whether a portion of the epidermis is situated under a bulla, or beside one. If outside a bulla, the epidermis presented almost no colored nuclei, staining by thionin showing an intermediary coloration in blue and pale violet. With an immersion lens, notwithstanding the cellular limits, and that the nucleus is replaced by a large hole (the vacuolization observed from the action of (1) Roentgen ray, (2) ultra-violet ray, and (3) high frequency discharges), the protoplasm is flattened and the fenestra of the mucous bodies enlarged. Here and there persists a nucleus in general elongated perpendicularly to the epidermis and presenting an

almost normal aspect. Above the altered mucous bodies there is no trace of the granular layer to be found. The corneous layer is quite thick and flaky. It preserves some almost normal coloring reactions. It is noted, however, that in certain points there are found some readily colorable epithelial nuclei, with a distinct reticulation. The protoplasm all around is scarcely or not at all apparent.

The epidermic lesions below the bulla are entirely different in their aspect. There is found an epidermic layer which with thionin colors violet, and which shows on its deep face some papillæ and some interpapillary cones. This layer presents two superimposed zones of different aspects. The more superficial one is very thick, appearing almost homogeneous to a low power lens. With a higher power there are found some nuclei which appear like lymphocytes migrating toward the bulla and a tissue of hyaline appearance. Also here and there, a flattened epidermic cell is outlined in turbid protoplasm. Some epithelial nuclei seem in contact with the bulla. The deep zone on the other hand is formed by an epithelium which has preserved its nuclei, and which is disposed in a single layer above the papillæ, while in many layers it is thickened to form the papillary cones.

The large bulla is limited by an extremely thin corneous layer. It contains a liquid which colors in a homogeneous fashion, and which by the orange G forms a veritable orange lacquer, sprinkled with polynuclear cells (eosinophiles) having large nuclei.

There exists a zone of transition, between the part of the epidermis underlying a bulla and the epidermis around the bulla, where large vesicles near to one another which are not yet joined with the principal bulla are observed. There is seen at first a subcorneous vesicle which is formed in the same manner as the large bulla, of which it presents a miniature in which the phenomenon of diapedesis is not present. There is observed, however, an irregular mass consisting of necrosed protoplasm. The other vesicles are formed in the same manner, but are deeper, they have

no regular limit, their walls are formed by a necrosed epithelium, having a vacant space in place of the nucleus, and presenting the coloring reaction already described.

In this, as in the preceding experiment, a hair follicle comprised in the section preserved its integrity taking a violet stain by thionin as in the normal state.

The dermic alterations are a great deal less important. A frank vascular dilatation is noted, but curiously not of the cellular focus. The connective tissue presents a turbid state. There is a true tumefaction. Under the bulla are seen two papillæ, filled with a homogeneous tissue, from which every vessel has disappeared. By the side of dilated vessels, there is a disappearance of certain others. A slight œdema is also observed, also some eosinophiles in migration toward the epidermis where they are found, also here and there outside of every vessel some red globules are seen.

Of this period, i.e. the fourth day, the gross alterations are epidermic, and it is impossible not to be struck by the differences between the epidermis underlying the bulla and the epidermis situated around the bulla. Leredde and Pautrier find this difference hard to explain, but advance the following hypothesis: In the tissues altered by the action of the light energy, the influence of the external conditions must be much more important than in the normal state, and that as much more as the dermic circulation is profoundly diminished, and as the perivascular changes are a departure from the normal. In these conditions it is fair to admit that wherever the epithelium is not protected it is desiccated. On the contrary, wherever there is liquid, the cells maintain their normal dimensions and are in a more favorable condition of vitality.

Fourth Experiment.—Biopsy made 8 days after the exposure to light energy. Contrary to the preceding periods the epidermis is thick, much more so than in the normal state. The derma presents quite important reactions which are proportional with those of a common inflammation. The thickening of the epidermis is due above all to the existence

of a layer underlying the mucosum, and which represents the granulosum profoundly modified. It is formed by the cells whose long axis is parallel to the surface of the skin. In numerous points these cells are confluent in a manner, indicating the formation of a homogeneous layer. They have very large nuclei, of the character of the nuclei of the mucosum, elongated parallel to the surface of the skin and often surrounded with a vacuole. There are observed in this layer some large granules of keratohyaline and numerous eosinophile cells and granules. Above this layer there is a solid stratum formed of corneous cells, of eosinophiles and of nuclei, the origin of which cannot be determined. These crusts are covered by a thin corneous layer, forming a universal investment. The character of the rete mucosum is remarkable. It is formed of relatively small cells with a very large nucleus. The intercellular spaces of the interior of the rete mucosum are dilated, while in the basal region the cells are heaped up one upon another, especially at the summit of the papillæ, where they are elongated and seem to naturally compress themselves. In all the thickness of the rete mucosum, but especially in the basal layers, there is found extensive karyokinesis in all stages. The preparation, observed the experimenters, could serve as a model for epidermic regeneration. There were no elements in diapedesis in the Malpighian bodies. The basal layer of the latter presents no longer the slightest pigmentation. Every trace has disappeared, and the skin was normally very much pigmented in this subject.

There is established in the derma, principally in the sub-epidermic part, the state of hyaline tumefaction that was remarked in the third period of the experiment. But there is found in this layer a greater number of vessels, even in the papillæ. These are extremely dilated—even to the formation of veritable lakes of blood. These vessels are bordered with endothelial cells, slightly numerous, but whose protoplasm much drawn out forms a wall. There are to be found in certain points in the endothelium of the vessels some

figures of karyokinesis. All of these phenomena are indicative that there are going on some phenomena of regeneration. Numerous hematin granules are found scattered outside the vessels. The connective tissue cells of the derma present a state of tumefaction which renders them more apparent and some are in karyokinesis. There are noted also here and there some lymphocytes, trying to form little rounded masses to occupy the lymph spaces. The mast cells are also a little more numerous than in the normal state, somewhat irregular in form, elongated and drawn out.

There is not only no trace of pigment in the basal layer of the Malpighian body, but there is also no trace of dermic pigment.

Histological Reactions Late in Appearing.—The important deduction from these experiments is the late appearance of the histological reactions. This slow reaction is specific of the action of chemical light energy. In this it differs markedly from the reaction established by the thermal energy of light. In heat burns the lesions soon disappear.

Freund<sup>1</sup> in instituting a comparison between the effects produced upon the skin by chemical light energy, thermal energy and that of the Roentgen ray, formulated the following laws as to the speed with which the reaction shows itself and the length of its duration: (1) The duration of the period of latency is in inverse ratio to the wave lengths of the active rays; in like manner the effect lasts longer in proportion as the wave length of the active rays becomes shorter. (2) The greater the intensity of the light the earlier does the reaction show itself and the longer does it last. If the intensity is less the reaction shows itself later and lasts for a shorter time.

Moeller<sup>2</sup> studied the subject of the action of light energy upon the skin, with a view of discovering what changes of tissue in the skin observable under the microscope corre-

---

<sup>1</sup>Radiotherapy and Phototherapy.

<sup>2</sup>Quoted by Freund.



sponded to the various clinical pictures of ordinary sunburn as well as more severe reactions. In his experiments he used skin from his own forearm, also skin from the head and ear of rabbits. As a source of light energy electric arcs of from 1,200 to 1,400 normal candle-power were used. The same apparatus as that used by Widmark in his investigations as to the cause of the erythema produced by electric light, and similar to the Finsen tube, was used by Moeller, the circulating water absorbing the heat, permitting thereby the activity of the chemically effective energy.

To secure various degrees of effect from a faint erythema with a consequent slight discoloration and pigmentation to the more marked changes of redness, swelling, formation of vesicles, necrosis, etc., the distance between the source of light energy and the skin to be acted upon and the time of exposure were varied. Repeated exposures of the same part of the skin to the action of the light were also made in furtherance of the same purpose.

Histological examination was made of specimens taken from the dermatitis of various degrees thus produced and subjected to microscopical examination as follows:

(1) Human skin after slight photo-electric erythema had been produced.

(2) Grayish toned thickened, rigid, but not yet pigmented skin from the head of a rabbit.

(3) Skin from an ear of an albinotic rabbit, hyperæmic, œdematous, dotted with little blisters.

(4) The ear of an albinotic rabbit showing more marked change, swollen on both sides, hyperæmic, showing ecchymosis and blisters.

(5) A piece of human skin, on which a mulberry-shaped, irregular, dark red hæmorrhagic blister had formed from exposure to the light energy.

From a review of the microscopic changes found in these various specimens, 1-5, the following conclusions are reached:

“The first change to show itself in the exposed skin is in

the vessels, which become microscopically more or less dilated. In connection with this the epithelium becomes moist throughout, and there is an abnormal formation of horny matter (parakeratosis of a changed darker color. The prickle-cell layer of the epidermis and the horny layer appear much extended. Within the latter is a deep-colored strip, which consists of horn cells within their nuclei, Fig. 5.<sup>1</sup>

Moeller surmises that the skin, which shows microscopically no other change than a yellowish-brown color, gets its color from the abnormal strip of nucleated cells. When the irritation produced by the light energy is more intense and of longer duration, exudation supervenes which is sero-fibrinous or rich in cells; it may often also contain red blood cells. The depth to which the changes extend are in proportion to the intensity of the light and the different nature of the skin exposed to the light, i.e., human or rabbit.

The extent to which the pores are affected depends upon the intensity of the exudation. The collagenous tissue begins to swell and becomes homogeneous, the epithelium swells, becomes relaxed, infiltrated and raised in bullæ. The interruption of continuity occurs in various places.

In the human skin it occurs approximately on the border line between the granular and horny layers, but this, by no means, precludes the possibility that on other occasions, i.e., with other skins and other degrees of light intensity, the bullous exudation may not arise differently. This would be analogous with the course of pemphigus for example, where in some cases the blisters appear between the cutis and the rete, in others between the granular and the horny layer. With more intense light thrombi are formed in the vessels of the cutis.

“In Moeller’s case the contents of the blister consisted of a fine reticulum, containing numerous red blood corpuscles and isolated leucocytes. Everywhere close to the surface numerous light, round blisters are to be seen with a more or less delicate covering membrane and a light centre. This is

<sup>1</sup>Figs. 6, 7, and 8 from Freund, Radiotherapy and Phototherapy.

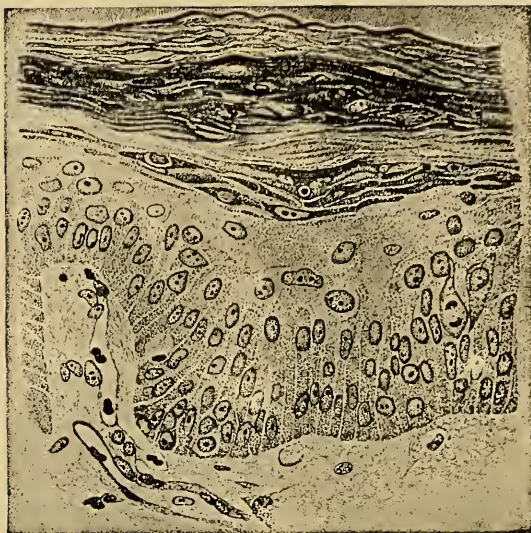

Fig. 6.<sup>1</sup>

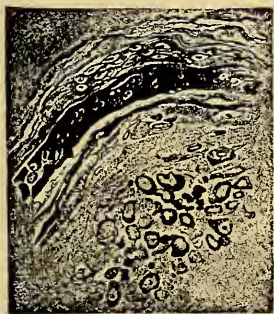

Fig. 7.<sup>1</sup>



Fig. 8.<sup>1</sup>

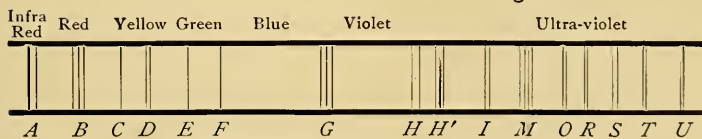

Fig. 9.<sup>2</sup>—Solar Spectrum.

<sup>1</sup>From Freund, Radiotherapy and Phototherapy.

<sup>2</sup>See page 272.



shown in Fig. 7. In some of the horn cells, loosened from the covering of the bullæ, may be seen very distinctly through the swelling of the cells, a longish rod-shaped hole in the centre in the place of the nucleus. In the remaining prickle-layer, too, which forms the base of the blister, cell changes occur, which vary from a simple swelling to a bullous degeneration," as is shown in Fig. 8.

These experiments of Moeller's are a very complete confirmation of those of Freund with the rabbit's ear as to the deeply penetrating action of the ultra-violet frequencies. "The disturbances were, when the light was very intense, most marked and also on the reverse side of the cartilage, in fact because of the larger number of vessels on that side, they were more noticeable there than on the directly illuminated side."

Moeller in his investigations proved further that when both thermal ( $50^{\circ}$  to  $55^{\circ}$ )<sup>1</sup> frequencies and intense ultra-violet frequencies were together active from the source of radiating light energy, they produced, as did the thermal frequencies alone when the ultra-violet were filtered out, more or less cerebral disturbance, sometimes even sudden death. Subsequent to intense radiation of that nature, the autopsy showed the skin of the head to be much swollen and a bloody gelatinous exudation to be present in the subcutaneous tissue. There was discoloration of the periosteum, the cranial bones and the dura, while they were covered with ecchymoses. The vessels of the brain surface were much dilated and upon it were numerous and in part confluent ecchymoses. Upon filtering off the thermal frequencies and exposing the animal to the ultra-violet frequencies alone, there was no central disturbance observable. From these experiments Freund<sup>2</sup> concludes that the action of the ultra-violet frequencies at any depth is relatively unimportant. No change of tissue was to be seen, even in the spongy subcuta-

---

<sup>1</sup>Not stated whether degrees Centigrade or Fahrenheit, but probably the former.

<sup>2</sup>Radiotherapy.

neous tissue, which is in direct contrast to the condition after exposure to the thermal frequencies.

There is caused by the action of both thermal and ultra-violet frequencies a hyperæmia of the cutis. This, when produced by the ultra-violet frequencies alone, is followed by discoloration and hyperplasia of the epidermis, especially of the horny layer, which in turn prevents further penetration into the tissues.

Pathogeny.—In the production of solar erythema and in electric light erythema, histological reactions of which have been given, the question presented to the experimenter is what part of the spectrum is particularly active. This was first hypothetically answered by Charcot, who placed it at the intensely chemical end of the spectrum. Bouchard<sup>1</sup> in his studies upon pellagra reached the same conclusion.

That solar erythema and photo-electric erythema are due to the chemical frequencies of the spectrum is then a fundamental fact.

In recent years this has been made the subject of experimental investigation and study by Widmark, Finsen, Freund, Bernard and Morgan. Each and all have arrived at the same conclusion.

Widmark<sup>2</sup> was the earlier experimenter. He analyzed the action of the different frequencies upon the skin, using for the purpose the shaven skin of a white rabbit and a water-cooled metallic tube quartz enclosed at one end, at the other half by rock salt and half by glass. This apparatus was used in connection with an electric arc. Through the side of the tube containing the rock salt, both with and without water, the typical erythema was developed followed by desquamation. This was not true of glass simply because of the physical inability of ultra-violet frequencies to penetrate its substance. The experiments of Finsen<sup>3</sup> are very

---

<sup>1</sup>Recherches Nouvelles sur la Pellagra, Paris, 1862, also Comptes Rendus Soc. de Biol. 1877.

<sup>2</sup>Hygiea, Festband No. 3, 1889.

<sup>3</sup>Mittheilungen aus Finsen's Lysinstitut, Leipzig; also Journal of Physical Therapeutics, Jan., 1901.

prettily illustrative. He utilized the flexor surface of his forearm, where the skin was very thin, placing upon it a plate of rock crystal and a series of bits of glass of different colors held in place by a few drops of glue. He also marked the initials of his name in India ink upon the surface of the same forearm. He then exposed it to the energy of an 80-ampère arc for 20 minutes. For the first half of the time, 10 minutes, he held his arm at a distance of .50 meter from the light of the arc, but as the heat was still very intense at that distance and as it could falsify the results he moved further away and for the last 10 minutes held it at .75 meter. The bits of rock crystal and glass were then taken off and the India ink removed. The skin presented a slight redness where the enumerated objects had been placed and a uniform redness elsewhere. Two hours later the redness began to disappear, the coloring being uniform throughout. Three hours later there was an increased redness but only in the unprotected regions. And this difference between the protected and unprotected skin went on increasing until on the next day the forearm was deep red, hot, sensitive to pressure, while the parts which had been covered by the pieces of glass or by the India ink were white in coloring and absolutely normal. On the other hand that part of the skin surface covered by the rock crystal (quartz) was red and hot as the unprotected part of the forearm. In several days this redness disappeared and was followed by desquamation, subsequently by very marked pigmentation which served as a brown base or background for the white spots which had been covered by the glass and the two letters, N. F. which had been marked in India ink. The experiment is illustrative of the difference between the erythema from thermal energy passing as it did in two hours, and the erythema from chemical energy, increasing after three hours, in the unprotected parts, going on to intense reaction, desquamation and pigmentation. Solar erythema also begins some time after exposure. Likewise in therapeutic uses it is the late reaction which characterizes an expenditure of

chemical light energy. It may appear in a few hours, a day or in 2 days time. When the skin is very thin, very vascular, this reaction appears very quickly, back of the ear, over the mastoid region for example. The author has observed it in that region 20 minutes after the exposure and of increasing severity from 36 to 48 hours.

Still more recent are the experiments of Freund.

Experiments as to Penetrability of Ultra-Violet Frequencies.—Freund<sup>1</sup> endeavored to establish for himself (1) whether the ultra-violet frequencies penetrated the epidermis and reached the lower layers of the skin, and (2) which part of the ultra-violet spectrum had this peculiar property.

The experiments were undertaken in the photo-chemical laboratory of the Imperial Graphische Lehr u. Versuchs-Anstalt, in Vienna, under the supervision of Professor Eduard Valenta. The material used was (1) fresh epidermis from burn blisters, (2) from the bullæ of pemphigus vulgaris, and (3) fragments of epidermis from animals.

Both of the first two were carefully removed with scissors, placed on glass plates, and preserved in the fluids withdrawn from the blisters by a small pipette, for the short distance from the sick room to the laboratory. The latter, like the two other preparations, were kept in a normal saline solution. A spectroscope with a grating was used, instead of the ordinary spectroscope which decomposes light into its constituent parts by means of a glass prism, for, as has been shown, glass is not transparent to the ultra-violet frequencies.

Previous experiments made by Strebel furnished qualitative proof by the lighting up of the fluorescent screen of the power of the ultra-violet frequencies under given circumstances to penetrate the skin, but only spectrographic examination of the penetrating light could determine definitely just which constituents of the light possessed this

---

<sup>1</sup>Radiotherapy: Freund, page 428.



power. Hence the use of the spectroscope with a grating as was done by Bernard and Morgan in their experiments.

The various membranes were spread carefully on one quartz plate and covered with another. Examination with a strong magnifying glass was then made showing that there were no gaps nor tears in the membranes. The quartz plates were then fastened in front of the opening of the "grating spectroscope." The spark light from a powerful Ruhmkorff coil, intensified by Leyden jars, was used; the electrodes between which the spark passed were coated with an alloy of lead, zinc and cadmium (Eder's alloy). The spectrum of the light from this source was then photographed, first with, then without, insertion of the preparations. The opening was 0.2 mm. wide, and the tissues were exposed to the action of the light for 15 minutes.

Under these conditions it was shown that absorption of the ultra-violet frequencies began at the cadmium line,  $\lambda = 3,260 \text{ \AA}$ , i.e., that this line under the given conditions is just recognizable on the film, while the light of the more refrangible rays no longer produces blackening, being, therefore, absorbed. There was no marked difference in the transparency of the three different preparations.

From this experiment Freund reached the following conclusion: "In consequence of this, we may assume with certainty that of the blue, violet and ultra-violet rays, those up to the wave length of the cadmium line, penetrate the epidermis."

Experiments were then made for the purpose of comparing the behavior of dried epidermis with that of moist and fresh normal epidermis. For this purpose, films of almost colorless horn and of horn slightly colored yellow, 0.5 and 0.56 mm. in thickness respectively were used. They were tested by examination under sunlight with the "grating" spectroscope. The yellowish horn, with an opening of 0.1 mm., and an exposure of 80 seconds allowed the light up to the Fraunhofer's line O,  $= 3,440 \text{ \AA}$  to pass through; under the same conditions with the colorless horn

the ultra-violet rays were effective up to  $Q = \lambda 3,287 \text{ \AA}$ . These experiments showed that dead epidermis has on the whole the same absorptive power as the living epidermis, but the permeability of colored, that is, pigmented epidermis, was shown to be sensibly less than that of the former.

Still more recently this subject has been studied by Bernard and Morgan in connection with their experiments on bacteria.

This part of the investigation comprised their third series of experiments. These were made to determine what part of the energy of the spectrum was active in exciting reaction on the part of the tissues, and while suggestive, are not yet regarded as conclusive by the experimenters.

The shaved skin of a rabbit, anæsthetized, to secure absolute quiet, was subjected to the spectrum, with the same spectroscopic arrangement as in their experiments upon bacteria, and no effect whatever was produced after an exposure of  $2\frac{3}{4}$  hours, with a current of 25 ampères. Guinea-pigs, white rats, frogs, and even a human arm were similarly subjected to the same spectrum, but with absolutely no evidence whatever of tissue reaction.

An additional experiment seemed to show that the rays exciting this reaction exist somewhere in the ultra-violet region. A rabbit shaven on both sides of its body was subjected to the action of the light from a 25-ampère electric arc passing through the water-circulating apparatus. Contact was made with the quartz disc on one side for 5 minutes. Then the other side was exposed in the same fashion, save that a sheet of glass was inserted between the water-cooling apparatus and the skin. The second exposure lasted an hour, and was made with a current of 25 ampères. On the following morning, on the side exposed to the rays through glass for an hour, absolutely no effect had been produced on the skin, while on the side exposed but 5 minutes through quartz and without the intervention of glass, there was a well-marked redness.

This, the author has clearly substantiated in the thera-

peutic uses of apparatus arranged with (1) glass plates or discs, (2) quartz discs, and also in experiments made upon culture plates, the bactericidal effect being active with the quartz, absent with the glass. The well-known transparency of quartz to the extremely short and high frequencies, ultra-violet, and their loss or absorption upon the interposition of glass, accounts for the results obtained both experimentally and therapeutically.

All rays of the spectrum, save the greater part of the ultra-violet, readily penetrate glass, and any effect obtained with apparatus containing lenses or globes of glass is due to the more feeble penetration of a few of the frequencies on the extreme edge of the violet as it merges into the ultra-violet region. To obtain the maximum action of ultra-violet and blue violet frequencies is to secure the maximum result in the treatment of such pathologies as lupus vulgaris, as has been done by Finsen.

It is then clearly proven that the frequencies which excite tissue reaction are to be found in the ultra-violet region, but it is not yet accurately determined in just what portion of the ultra-violet spectrum they are located.

Chronic Lesions Due to the Action of Chemical Light Energy upon the Skin.—Chronic lesions of the skin are established by the chemical energy of light which manifest themselves (1) by pigmentation, and (2) by vascular modifications.

Vascular Alterations Produced at the Level of the Skin by the Chronic Action of Chemical Light Energy.—Some months after the experiment upon his arm Finsen<sup>1</sup> observed no trace of the intense reaction which had taken place in the unprotected regions. One morning about 6 months after the experiment when at his toilet, upon rubbing his skin he observed that the part of the forearm which had been the seat of the photochemic erythema presented a much more marked redness than the parts which had been protected by

---

<sup>1</sup>Journal of Physical Therapeutics, April, 1901.

the glass plates. This difference finds its explanation in a persistent dilatation of the vessels and capillaries of the skin following upon the action of the light.

In the author's experience there has occurred a permanent and marked dilatation of all the capillary blood vessels of the inner and outer aspect of both legs, but especially of the inner, in the person of an invalid lady, from prolonged and constant exposure to the chemical light energy from a hard-coal fire. By reason of her profound anæmia and imperfect circulation she was obliged to sit very near the fire for hours at a time, and was in the habit of raising her skirts to prevent their being scorched. In consequence there is not only the dilatation, but also marked pigmentation, and after a lapse of from 4 to 5 years it is as evident as at first. The action of thermal stimuli at this time causes a very prompt reaction so marked as to outline the anastomoses of the superficial capillary vessels.

Finsen established the dilatation of the capillaries in his experiments upon the tail of the tadpole, while Leredde and Pautrier showed it by their examination of sections of the skin acted upon by light energy.

Finsen and Moeller proved by experiment a peculiarity of light reaction corresponding precisely to that observed by Freund with Roentgen ray reaction, viz., that skin which has been exposed to the influence of powerful chemical light energy, blue-violet and ultra-violet frequencies, retains for a long time, months and years after the first light erythema has disappeared, a peculiar predisposition to react with remarkable promptness to mechanical, chemical and thermal stimuli, and also to internal influences, psychical stimulus, for example. This reaction is evidenced by a very quick reddening of the part.

The more active cutaneous circulation established by light is a condition of better function for the skin.

This is true of the physiological action of ordinary sunlight upon the cutaneous covering. In this connection, however, it is the action of concentrated light upon the skin.

It is no longer an acute phenomenon of a common inflammation but a chronic phenomenon of some sort, producing itself after long periods of time. But other tissues are influenced by this action. It was observed by Berthold<sup>1</sup> that the nails, the beard and the hair grew more rapidly in summer than in winter. Finsen<sup>2</sup> inquired of the coiffeurs, and according to them it is a current observation that it is not necessary to shave so often in winter as in summer. It has been observed in Finsen's clinic that both patients and nurses acquired a thicker growth of hair on those parts repeatedly exposed, and for long periods to the powerful electric arc energy. It has also been proven, and it only further illustrates the same phenomena, that amphibia and fishes whose limbs have been broken off grow again more rapidly in the light than in the dark.

The explanation lies in the fact that in the summer, by reason of the abundance of light, the skin is better nourished than in the winter; with the amphibians and fishes there are more active circulatory conditions in light than in darkness.

This action on the cutaneous circulation not only produces a temporary hyperæmia, but, as has been indicated, a lasting one, a condition which unquestionably influences favorably the diseased area, subjected to the action of the chemical frequencies. In all diseased conditions, where the vital processes are below normal, whether accompanied by the presence of a germ or not, as in tuberculosis, the best result is to be obtained by securing a hyperæmic condition of the tissues. To this end, every means is tried to stimulate circulation and to produce the hyperæmia necessary to establish restoration to normal conditions as in a tuberculous lung, joint, gland or skin lesion, or to establish healing, as, for example, in a varicose or tubercular ulcer.

Chemical stimulants in the form of lotions, ointments, even injections are used; the aid of electricity is invoked either to produce the characteristic action of the current, or

---

<sup>1</sup>Mueller's Arch. für Anat. und Physiol., 1850, p. 158.

<sup>2</sup>Mitt. aus Finsen's med. Lys., Vol. I., p. 118.

by means of it to deposit within the tissues the salt of an oxidizable metal. By the action of light, the same effect is produced, an effect which is both deep seated and lasting. The necessity for this hyperæmia is, if possible, more necessary in tubercular affections than in other pathologies. It is by reason of the deeply penetrating action of light that favorable results ensue.

Applications of typical chemical stimuli are very superficial in their effect. The far-reaching and permanent effects obtained by the light vibrations are comparable to the effects produced by the deposition of salts of oxidizable metals at the anode or drugs in solution or suspension, both anaphoric and cataphoric medication. By the action of the salts of oxidizable metals, far-reaching and lasting results are obtained.

It is believed that the chemical products of the bacteria are accumulated by the action of the light, a condition which is unfavorable to their development. As the chemical frequencies of light, especially the ultra-violet rates, have the power, by reason of their short wave length and very high frequency, to agitate bacteria, shake them up as it were, a physical condition inimical to their vitality, they must by this action be deprived of their oxygen. Such a deprivation would mean an accumulation of their chemical products. Meanwhile the same action which results disastrously to them gives an impetus to the normal oxygenating power of the blood.

There is no radical difference in the mode of action of the different means employed for the production of a physiological irritation. Whatever their nature, they follow a universal law, and the result of their use is both inhibitory and constructive. Bacteria are inhibited, morbid growths due to them resolved, metabolic perversions and their skin expressions overcome, and all the while the beneficent action of light upon the organism as a whole goes on tending to an elevation to the normal standard.

The formation of connective and scar tissue depends

always, whatever its locality or however formed, upon a preceding hyperæmia.

It has been stated by Lang<sup>1</sup> that the pressure employed by means of compressors was the curative factor, and he is responsible for the statement that he has cured lupus by pressure alone. This has not only not been substantiated by any other observer, but it has been proved beyond peradventure that it is the penetrating light, chemically active, which excites tissue reaction and which cures lupus.

But side by side with the vascular modifications, another phenomenon occurs from the prolonged action of chemical light energy upon the skin, viz., the production of pigment. This may be regarded as a process of defence or adaptation. Beyond question it is the act of defence on the part of the skin in relation to the chemical rays. It will be remembered in considering the rôle of light in the pigmentation of animals that the deepest part of their coats is always the dorsal surface, which is the one most exposed to light. Of equal interest and pertinence in this connection are the experiments of Packard and Viré on the cavernous species of animals. (See Action of Light on Animal Organisms; the Influence of Light on Pigmentation.) In man the pigment production appears to be the same in all parts of the body exposed to light. The action is not due to the wind, to sea-air, or exposure to inclemencies of weather, but is one of chronic alteration involving the pigment cells due to chemical light energy. As is commonly observed, it follows sunburn. Both Finsen and Widmark noted a consecutive pigmentation in their experiments. Pigmentation left after exposure to strong light comes from the accumulation of hemosiderin in the interstices of the tissues.

The Rôle of Pigmentation as a Process of Defence.—This is established in part by the more active cutaneous circulation consecutive to the first chemical light erythema.

---

<sup>1</sup>Wiener dermatolog. Gesellschaft and IV. Internat. Congress f. Dermatologie and Syph., Aug. 2, 1900, Compt. rend., p. 171, quoted by Freund.

The red medium, the blood, absorbs the violet and ultra-violet frequencies more than any other tissue. By reason of the stimulus thus imparted there is increased oxygenating power, i.e., the red blood corpuscles are more richly stored with oxygen. This doubtless serves as an appreciable agent of protection. By reason of the histological changes, i.e., an œdematous, thickened, spongy epidermis, the penetration of the chemical frequencies of short length is prevented. The practical application of this should not be lost sight of in therapeutic applications, i.e., not to repeat an exposure until the reaction has sufficiently subsided; for an epidermis in this condition cannot be transparent to light, that is, permit its absorption.

It is the pigmentation, however, which plays the most important part in the process of self-defence. Finsen and Giard, in France, have both voiced the theory. No better illustration of it is to be found than in the dark coloring of the peoples of the tropics.

Pigmentation as One of the Factors of Natural Selection.—Perhaps there is some evidence of this. It was studied by Böhn,<sup>1</sup> who, in considering the struggle that living beings sustain among themselves and against the diverse agents of the external world, declares that there results from the *ensemble* of these phenomena an impression of harmony. Struck by the rôle played by pigment, Böhn admitted by the side of physical and chemical harmonies, which only reveal themselves after much analysis of biological phenomena or not at all, pigmentary harmonies.

Savants have been struck by these harmonies of colors, and to the minds of Wallace, Darwin, Poulton, Giard, they play an important part in the affinities of beings among themselves and in their relations with the external media. The theory is known under the name of mimetism.

Pigmentation as a Process of Adaptation.—It is probable that pigmentation may be regarded quite as much a

---

<sup>1</sup>L'Évolution du Pigment, loc. cit.



process of adaptation as a process of defence. But even so the two functions run imperceptibly the one into the other.

Leredde and Pautrier are of the opinion that in pigmentation in the animal kingdom and upon the human skin the process may be one of adaptation by which the pigment might utilize the chemical energy of the spectrum, transforming it into energy, which in turn may be utilized by the organism in a form of which nothing is known. They state in this connection an admitted fact, viz., that the sobriety of the races of the tropics is well known, and that the sum total of work of which they are capable is entirely disproportionate to their apparently insufficient ration. The explanation of the difference in alimentary régime between the people of the north and the people of the south, which is always offered, and so far as is known, is the correct one, is that because of the difference of temperature the former require more food to resist the cold than the latter. These authors raise the question as to the light energy, whether it may not also play a part in these phenomena. The author would say that because no such relation is known and proven, the possibility of its truth is not precluded. All about us in nature is a wealth of unanalysed truth. In so perfect and stupendous an organization as the universe, there is an explanation for every observed fact. To the author's mind it seems more than possible that when biological phenomena are more fully analyzed and understood, there will be found a correlation of the first order between the radiant energy of the sun and all the phenomena of life. Reverting, however, to known facts in the wealth of observed phenomena to the minutest detail of the action of light energy upon the skin as studied by Widmark, Finsen, Freund, Bernard and Morgan and Leredde and Pautrier, there is builded a scientific foundation upon which future biologists may hope to rear a superstructure of as carefully analyzed biological phenomena, which in its turn will tend to elucidate the relation of life to light.

The Action of Light Energy upon the Blood.—As an

evidence of the relation between light and life is the fact that certain constituents of animal tissues permit of the free passage of light. This transparency is of practical value in the use of light as a diagnostic agent, a method much in use before the discovery of the Roentgen ray.

Tissues differ in regard to their transparency to light. It is a matter of their structural density and the chemical nature of the layer, but especially the uniformity of the tissue, both as regards the nature of its matter and its density. All of the substances of the living organism are not equally transparent to the different frequencies or colors of the spectrum. For example, the blood transmits the red frequencies but absorbs the more refrangible frequencies. Freund's experiment showed that in the living frog's web, the blood absorbs all the light from Fraunhofer's line H. or wave length 3,964 Ångstroms.

In order to have an actual picture of the transparency of the living tissue to the red frequencies, let the reader place the hand over a source of light, or place a small incandescent lamp within the mouth. Light is used in this way as a test for hydrocele. In the transmission of the longer and slower frequencies in all these instances, the fact that it penetrates the skin is shown. A diamond ring may be made to sparkle when covered with a finger, for example, which is illuminated from above, and even when the finger is covered with white or chamois leather. This was first shown by Des-saignes. Gebhard<sup>1</sup> imbedded a hand so completely in plaster of Paris, in the hollow of which he had placed a photographic plate, that only the back of it was exposed to the luminous energy of an electric arc for 20 minutes. The plate was removed to a dark room and developed. It was blackened, and the outlines of the hand and fingers were distinctly seen. This demonstrates that not only light, but light chemically active passed through the hand.

From the experiments of Gadneff<sup>2</sup> the nature of the

---

<sup>1</sup>Die Heilkraft des Lichtes, Leipzig, 1898, p. 131.

<sup>2</sup>Quoted by Boubnoff, Arch. f. Hyg., Vol. X., p. 335.

penetrating energy is shown. He filled small tubes with chloride of silver, sealed them hermetically, and then by the aid of a trocar carried them under the skin of living dogs and cats. Some of the animals were placed in captivity in darkness, while others were allowed to run free exposed for some time to the action of the sunlight. In the latter, the chloride of silver was blackened, in the former no change had taken place. Finsen's experiment on his wife's ears not only demonstrates the passage of chemically active light, but proves that the blood interferes with its passage to a very great extent.

Still another experimenter, Darbois<sup>1</sup> showed that a piece of photographic paper introduced into the mouth under the skin of the cheek between two watch glasses was blackened after one minute's exposure to the light energy from an electric arc used in connection with a Finsen concentrator directed to the outside of the cheek.

Solucha<sup>2</sup> filled tubes with strips of silver-bromide-gelatin inserting them under the skin of dogs and sewing up the incisions made to receive them. He used a projection apparatus at 50 to 65 volts pressure and from 10 to 20 ampères current strength. The bromide of silver was seen to be decomposed after one minute. When the tubes were carried down deep into the glutei muscles on the other hand, the sensitive paper was not acted upon, showing that the light did not penetrate so deeply. The decomposition soon set in when similar tubes were placed behind the ear or inside the cheek of patients in the first instance after half a minute, in the latter after two minutes, while when placed behind the forearm or in the fist the sensitive paper was unchanged after 15 minutes. By an increased light intensity, say 25 ampères at 110 volts pressure, the entire body can be penetrated, for under such conditions the sensitized gelatin film was chemically altered even when placed upon

---

<sup>1</sup>P. Darbois, *Traitement du Lupus Vulgaire*, Thèse de Paris, 1901, p. 80.

<sup>2</sup>Quoted by Freund.

the opposite side of the body from the part exposed to the light. Solucha for example placed it at the back of the neck, when exposing the throat or at the right side of the body when the light came from the left.

As further proof of the penetrating power of even chemically active light energy, are the experiments of Kime.<sup>1</sup> For a source of light energy the sun's rays were utilized and the light passed through the thorax to the sensitive film placed upon the patient's back.

Finsen observed distinct weakening of a bacteria culture which he placed back of the ear of a white rabbit and through which he passed concentrated sunlight. He also showed that the light passed through the compressed lobe of a human ear could be broken up clearly into all the colors of the spectrum. Strebel<sup>2</sup> utilized the fluorescent property of ultra-violet energy to prove the penetrability of the human skin in the following manner: A piece of skin freed from all fat tissue was fixed between small quartz plates; all of the colored frequencies of light energy were excluded and it was exposed to ultra-violet energy, produced by the induction sparks from zinc and aluminum electrodes. The distance between the skin and the spark was 140 cm. Upon placing a fluorescent screen behind the skin it showed that a human ear compressed between two quartz plates absorbed isolated ultra-violet frequencies completely.

That there is a penetration then not only of energy which affects the visual organs but of the energy which is chemically active through animal tissue, is thus very completely demonstrated. The penetration may take place through tissues of considerable thickness under certain conditions. The ultra-violet frequencies alone barely penetrate the epidermis, even when applied in a concentrated form but when combined with the blue indigo and violet, the complex of frequencies is much more penetrating, being absorbed by the first thick layers of the blood vessels; while the red and

---

<sup>1</sup>New York Medical Record.

<sup>2</sup>Deutsche Med. Wochenschrift, 1901, Nos. 5 and 6.

infra-red permeate the cutis and pass into the deeper tissues. The tissues of the body to a considerable depth are diaphanous to the red frequencies as is shown by their transmitting effect. With a miniature incandescent lamp of small candle-power it is possible to transilluminate the pelvic tissues to within two inches of the umbilicus in a subject of ordinary avoirdupois and thickness of abdominal fat. That these longer and more deeply penetrating waves are subjected to some modification of their motion, a temporary arrest, as suggested by Strebel<sup>1</sup>, seems possible. Their wave length is entirely out of proportion to the size of molecular structure and it does not seem possible that the latter would insure their temporary arrest, for when a wave strikes an obstacle that is much smaller than the wave length, the wave gets by the obstacle without much difficulty and in that event little or no energy is expended, therefore little or no work is done.

From this physical law it would appear that in so far as the structural nature of the tissues permits of the transmission of the energy of red light, or the long and slow frequencies there is little or no energy expended or work done in them. On the other hand in their action upon the deeper and more translucent structures the ultimate energy would only heat, as it could not penetrate so far without absorption. The disruption of molecules and consequent effect upon molecular structure is more likely to occur the higher the frequency of the oscillating light corpuscles.

Light is converted into heat waves and perhaps into long electrical waves. The energy of the spectrum is transformed into other forces, the forces which are inherent, viz., electric, osmotic and the vibrational action of molecules or other mechanical energies. A direct action upon the chemical processes and stimulation of the functions of the tissues and protoplasm is established reflexly by exposure to light energy. Light acts as light by its chemical activities alone.

---

<sup>1</sup>Die bisherigen Leistungen der Lichttherapie. Berliner Klinik, February, 1902.

and the primary action is upon the blood, by which its oxygenating power is increased.

If in consequence of the exposure of large body surfaces to the influence of strong light the accumulation of hemosiderin in the interstices of the tissues, that is, the giving off of blood coloring matter, takes place to a very great extent, a certain impoverishment of the elements of the blood and the coloring matter may ensue. As a result the organism may be stimulated to increased functional activity to compensate for this change. This theory advanced by Löwenthal<sup>1</sup> offers a rational explanation of certain metabolic changes which take place under the influence of light energy.

The influence which light energy exercises upon the blood and capillary systems in living organisms is one of great importance. By its action blood vessels undergo a change in form, as has been fully demonstrated by very extensive experimental work. The action upon the blood stream itself, however, is one of absorption and the absorption of energy means the impartation of a stimulus to the functioning parts or whole of the living organism. In this instance the stimulus is imparted to the blood corpuscle and the direct action of the energy absorbed appears to be upon the storer of oxygen or the red blood corpuscle. By the increase of oscillating movement or swing of the corpuscle there must be an increased energy of action according to every physical law. It is the penetrant chemical frequencies, the blue, indigo violet and ultra-violet, that thus act upon the red media. From accumulated experimental data and clinical observation, as well as from a study of the physical laws of light and their correlation to the living organism, is found constant proof of this fact.

Spectrum of Hæmoglobin.—A glance at the constitution of the red blood corpuscle and at the spectrum of hæmoglobin cannot fail to be of interest and value in the study of the action of light energy upon the blood.

<sup>1</sup>Deutsche Med. Zeitung, 1899, No. 72.

Human red blood corpuscles singly are biconcave circular discs of a yellow color with a slight tinge of green; they seem to be devoid of an envelope, are certainly non-nucleated and appear to be homogeneous throughout. Each corpuscle consists (1) of a framework, an exceedingly pale, transparent soft protoplasm—the stroma; and (2) the pigment or hæmoglobin, which impregnates the stroma much as fluid passes into and is retained in the interstices of a sponge. Hæmoglobin possesses some remarkable properties. Although it is a crystalloid body it diffuses with difficulty through an animal membrane, owing to the large size of its molecule. (3) It readily combines with oxygen to form an unstable and loose chemical compound, oxy-hæmoglobin. (4) This oxygen it gives up readily to the tissues or other deoxidizing agents. (5) Its composition is very complex, for, in addition to the ordinary elements present, in proteids, it contains a remarkable amount of iron (0.4 per cent.).

Graffenberger<sup>1</sup> maintains that the mass of hæmoglobin contained in the red blood corpuscle is lessened in the dark and that from a prolonged stay in the dark there is a diminution in the total quantity of the blood.

Marti<sup>2</sup>, in his experiments upon rats, established the fact that the deprivation of light lessens the number of red blood corpuscles, and to a less extent the amount of hæmoglobin, while from exposure to strong light continuously, the formation of erythrocytes and also of hæmoglobin was stimulated. Hæmoglobin is then active in the absorption of these chemical frequencies and in the relatively large size of its molecules is to be found a physical condition favorable to the physical action of these periods of oscillating light corpuscles.

The stimulation imparted results in an increased activity of oxygen absorption and the formation of oxy-hæmoglobin. A study of the spectra of oxy-hæmoglobin and meta-hæmoglobin, both absorption and flame, should be of the

<sup>1</sup>Pflüger's Archives, 1892, Vol. LIII, p. 238.

<sup>2</sup>Verh. d. Congress f. Innere Med., 1897.

same if not greater interest to the therapist than it is to the physiologist and pathologist. A glance at the spectrum of hæmoglobin demonstrates that it is no exception to the rule. The general coloring in the case of well-oxidized arterial red-blood corpuscles is scarlet; with venous blood a darker red. A single corpuscle shows a yellow coloring with a slight tinge of green.

Thus in the green, yellow and red coloring is to be found the evidence of the energy of radiation of the emitting or, in this instance, the fluorescent tissues of the body, all of them below the longest wave length of the visible chemical frequencies, or the blue.

Flame Spectra.—In the ashes of almost all organs are to be found the bands, which indicate the presence of potassium and sodium.

Absorption Spectra.—If a solution of blood be placed between the slit of the spectroscope and a source of light, all the rays of colored light do not pass through it—some are absorbed; many yellow frequencies or rays are absorbed by blood, hence that part of the spectrum appears dark to the observer. This should bear a relation to the presence of sodium in the blood, and its constant presence in the spectra of all sources of light. On account of this absorption such a spectrum is called an absorption spectrum.

If sunlight be allowed to fall upon the slit, the spectrum shows a large number of lines, Fraunhofer's lines, which occupy definite positions in the spectrum. These lines are indicated by the letters A, B, C, D, E, F, G, H, H<sub>1</sub>, etc., as shown in Fig. 9.<sup>1</sup>

Oxy-hæmoglobin.—Oxy-hæmoglobin behaves as a very weak acid, and occurs to the extent of 86.78 to 94.30% in any human red corpuscles. It is formed very readily whenever hæmoglobin comes in contact with the oxygen or atmospheric air. Oxy-hæmoglobin is a very weak chemical compound, and is slightly less soluble than hæmoglobin; its

\*See plate facing page 253.



spectrum shows in the yellow and the green two dark absorption bands.<sup>1</sup> It occurs in the blood vessels circulating in arteries and capillaries, as can be shown by the spectroscopic examination of the ear of a rabbit, of the prepuce and the web of the fingers.<sup>2</sup>

Spectrum of Oxy-Hæmoglobin.—In the spectrum of a dilute solution of hæmoglobin crystals of arterial blood, part of the red and violet frequencies are absorbed, but two well-marked absorption bands exist between D and E. The line nearest D, i.e., next the red end of the spectrum, sometimes designated by the letter a, is narrow, sharply defined, and black at its centre, and in its wave length corresponds to wave length 579.

The other absorption band near E, conveniently designated by b, is broader, not so dark, and its edges are less sharply defined. Its centre corresponds to wave length 553.8.

In very dilute solutions the band is the only one visible. In strong solutions the two bands fuse, but are again made visible as two on dilution of the blood.

The spectrum, therefore, necessarily varies with the strength of the solution. With a 1% solution all the spectrum disappears with the exception of the extreme red, and as the dilution continues, the orange, green, blue, indigo and violet are successively seen. With 65% solution of  $\text{HbO}_2$  there is only one absorption band.

Spectrum of Reduced Hæmoglobin.—By adding to a solution of hæmoglobin reducing substances—e.g., ammonium sulphide, iron filings, Stokes's fluid (tartaric acid, iron protosulphate, and excess of ammonia)—the two absorption bands of the spectrum disappear, and reduced hæmoglobin (gas free) with one absorption band is formed. The color changes from a bright red to a purplish or claret tint. The two bands are reproduced by shaking the reduced hæmoglobin with air, whereby  $\text{HbO}_2$  is again formed. So-

<sup>1</sup>Landois and Stirling, p. 26.

<sup>2</sup>Ibid.

lutions of oxy-hæmoglobin are readily distinguished by their scarlet color from the purplish tint of reduced hæmoglobin.

According to Hermann, the absorption band of Hb is not a single band, there being in addition a very narrow band toward the red end of the spectrum, but separate from the chief absorption band by a small interval.

Methæmoglobin is a more stable crystalline compound than oxy-hæmoglobin. It contains the same amount of O as HbO<sub>2</sub>, but in a different chemical union, while the O is more firmly united with it. It shows four absorption bands like hæmatin in acid solution of which that between C and D is distinct; the second is very indistinct, while the third and fourth readily fuse, so that these last two bands are only seen with good apparatus.<sup>1</sup>

Freund undertook to determine to what extent the more refrangible rays were absorbed by the blood. To this end a few drops of blood from a finger tip were squeezed on to a quartz film, which was surrounded by a rim of paper 0.17 mm. wide, and covered with another quartz film. The blood completely filled this space of 0.17 mm. This layer showed a uniformly red color without any light space. Upon examination with a little pocket spectroscope, the usual absorption spectrum of blood was seen, with the characteristic absorption band between the Fraunhofer lines—D and E in the greenish yellow. By the aid of a small glass spectroscope and using sunlight, the spectrum was photographed. With an exposure of 5 minutes, the image of what had been seen was reproduced showing that absorption began at F  $\frac{1}{2}$  G, and from that point onward, in the direction of the ultra-violet, practically no action on the photographic plate was discernible.

A further experiment was made in order to discover the behavior of living fresh epidermis, beneath which the blood is circulating. A frog was put under curari, then two toes of a hind foot were fastened with pegs along the edges of

---

<sup>1</sup>Landois and Stirling.

a triangular hole cut in a sheet of cork, in such a manner that the web of the foot was fixed in front of the opening of the slit of the spectroscope through which solar light was allowed to fall. The opening was 0.15 mm., the exposure, 5 minutes. Under these conditions the line H ( $\lambda$  3,964 Å) was absorbed. It is interesting to know that so many of the frequencies from the more refrangible part of the spectrum should still be able to pass through when the thickness of the membrane and the quantity of the blood contained in it is considered. It follows, therefore, that a considerable portion of the ultra-violet frequencies emitted by various sources of light pierce the epidermis, and are able to reach the lower layers of the skin. So far as is at present known Freund finds that these penetrant frequencies of the ultra-violet spectrum, roughly speaking constitute a third part of the ultra-violet spectrum as at present known. There are several different factors governing these results, the intensity of the source of light, the duration of the action, and the thickness of the exposed layer. Under more suitable conditions, such as obtain, for example, in the treatment of lupus patches and nodules by Finsen's method, a more profound penetration of the epidermis by these very short and high frequencies is possible.

It is, therefore, evident that blood absorbs light to a very great extent, and in a somewhat peculiar manner. This is shown by the characteristic absorption spectra of greenish yellow obtained by Hoppe Seyler, and in blue violet by d'Arsonval. It is further emphasized by the experiments of Freund made to determine the degree of penetration of the ultra-violet frequencies. The classic experiments of Finsen evidence additionally the absorptive power of the blood for blue violet light energy. He placed a piece of sensitized (aristo) paper back of the lobe of his wife's ear. The concentrated beam of light from one of his arcs was then directed upon it, securing the passage of the more chemically active frequencies, or the blue-violet and ultra-violet. Nothing was done in the first experiment to

cut off the circulation. After an exposure of 5 minutes there was no action whatever upon the paper, i.e., it was not blackened. Upon compressing the ear between 2 glass plates until it appeared pale and bloodless, a second exposure was made for 20 seconds, resulting in a blackening of the paper. This demonstrates very clearly the fact that the blood to a very considerable extent prevents the penetration of the chemically active frequencies into the tissues, while the absorption spectrum of oxy-hæmoglobin indicates that the blood absorbs them. From the constitution and the absorption spectrum of oxy-hæmoglobin it is clear that the hæmoglobin is an active absorbent of light energy. It has been pointed out that the absorption spectrum of oxy-hæmoglobin is different from that of methæmoglobin.

It has been shown by Quincke<sup>1</sup> that hæmoglobin gives off its oxygen more quickly in the light than in the dark. In darkness the oxy-hæmoglobin band in the spectrum vanishes. This proves that light energy increases the oxidizing power of the blood, and proportionately the processes of oxidation in the living organism.

Absorption of light (see chapter on Fluorescence) is connected with phosphorescence and fluorescence. Fluorescent bodies exhibit corresponding absorption-spectra, and, as they absorb the ultra-violet frequencies more or less completely, they all fluoresce in this region of the spectrum.

The blood and the lymph serum are fluorescent bodies, and as such are amenable to the same physical laws as other fluorescent substances. Their fluorescent property indicates the absorption by them of the higher and more refrangible frequencies blue, indigo, violet, and ultra-violet. Spectroscopic analysis of rays emitted by fluorescent substances has shown that in them the blue and all frequencies above it are suppressed. Therefore the light so filtered ceases to excite fluorescence in any other substances exhibiting the same properties.

---

<sup>1</sup>Pflüger's Archives, 1894, Vol. LVII., p. 134.

The question of the frequencies which excite the normal fluorescence of the blood, or for that matter, any tissue of the living organism which is naturally fluorescent, is settled by this physical law. It is further substantiated by experimental data which show conclusively that these penetrant chemical frequencies are the frequencies which are absorbed by the blood.

The action of the light energy then, especially the penetrant frequencies effective chemically upon the blood, is very clear of comprehension. In the ability of the blood and other tissues of the living organism to function as a transformer under the influence of the more intensely chemical frequencies or rays of the greatest refrangibility of light is to be found the rationale of its action, both in health and in disease. There is doubtless an equally scientific explanation of the action of the frequencies below the blue, but it yet remains to be made. One thing seems certain that light produced within the body by means of drugs having fluorescent properties cannot, according to physical laws, have any effect upon the blood or other naturally fluorescent tissues of the body, if the frequency so produced is of lower order than the blue.

In discussing the action on bacteria and therapy of fluorescent substances under the action of light, it is pointed out that the results obtained by exposure of fluorescent substances in solutions, or when applied to superficial surfaces, eosin, for example, to light energy of high frequency, ultra-violet, the effect produced is due to the act of fluorescent stimulation, just as it is with chlorophyll. This stimulation when once established is a continuing factor both in normal and a wide range of abnormal conditions, and the stimulation imparted to the blood by the action of light under physiological conditions is the same. It lasts for varying periods of time within physiological limits, but the maintenance of normal fluorescent properties of blood and fluorescent tissues must depend upon (1) frequent renewals of the stimulation by exposure of the body in part or

altogether to the action of sunlight, and (2) upon the absence of pathological conditions which interfere with the ability of the normal fluorescent tissues of the body to function as transformers of the frequencies from the blue on up into the ultra-violet region. The plasmodium malaria is a notable instance of a parasite which destroys the normal condition of fluorescence.

But it does not seem unreasonable to believe that in a modification of the blood, such as is induced by the presence of a parasite as in malaria, of a toxin or poison as in syphilis or sepsis, of a bacillus as in tuberculosis, or as the impoverishment of anæmia both the rate and volume of atomic motion must be altered. There may be a great deficiency in oxygen, iron, in the saline constituents, sodium, potassium, ammonium, and calcium, which must mean an inability on the part of the blood to fix the energy transmitted to it, that is, to absorb energy of radiation at the degree which permits the fluorescent condition normal to it under physiological conditions. When the departure from the normal is not too great, in the conditions mentioned, an expenditure of light energy if sufficiently localized and concentrated, as in a cabinet for general conditions, and by strict localization and compression in special lesions, should result in physiological fluorescent stimulation. This stimulation to the oscillating swing of the atoms cannot fail of response.

Red blood corpuscles are diminished in size by septic fever, inanition, morphia, increased bodily temperature and  $\text{CO}_2$ , but they are increased by  $\text{O}$ , by cold, quinine, etc. They are also diminished, at most one-half, by hemorrhages and also undergo a physiological diminution as a result of menstruation. Under ordinary physiological conditions this is a moderate loss and they are replaced within 28 days. When the loss is excessive the period of replacement may extend over 5 weeks with the result of lowering all the vital processes, as in menorrhagias and metrorrhagias. This diminution of red blood corpuscles, with lowering of the vital processes, is more or less continuous.

The size of the red blood corpuscle is also diminished in acute fevers. In certain forms of anæmia there has been found (Hayem) considerable variation in the size of the red blood corpuscles; in chronic anæmias the mean diameter of the corpuscle is always less than normal. There is moreover a persistent alteration in the volume, coloring power and consistence of the corpuscles, consequently a want of accord between the number of the corpuscles and their coloring power, i.e., the amount of hæmoglobin which they contain. In pernicious anæmia, in which the continued decrease in the red blood corpuscles may ultimately produce death, there is a severe affection of the blood-forming apparatus.<sup>1</sup> The corpuscles assume many abnormal and bizarre forms, often being oval or tailed, irregularly shaped and sometimes very pale; while numerous cells containing blood corpuscles are found in the marrow of the bone. In this disease, although the red blood corpuscles are diminished in number, some may be larger and contain more hæmoglobin than normal corpuscles. In chronic poisoning by lead or miasmata and also by the poison of syphilis, the red corpuscles are likewise diminished.

The size of the red blood corpuscle also varies in health and disease and dwarf corpuscles or *microcytes* are regarded as young forms and occur plentifully in all forms of anæmia. On the other hand "giant" blood corpuscles or *macrocytes* are constant in pernicious anæmia, and sometimes in leukæmia, chlorosis and liver cirrhosis. They also appear in abnormal forms after severe burns while a disintegration of the corpuscle has been observed in various diseases, as in severe malarial fevers.

These physiological facts concerning (1) the normal condition and function of the red blood corpuscle as the oxygen storer of the blood, and (2) its condition in disease, when taken in connection with the physical effects and physiological action of light serve to illuminate the intimate

---

<sup>1</sup>Landois and Stirling.

relationship between animal life and radiant energy and to emphasize not only the fact that continued existence is dependent upon it but the physical reasons for the same.

Light Energy in Relation to the Menstrual Function and Bearing upon the Blood-Forming Process.—According to Eulenburg it is a fact that women of the far north are very much more predisposed to amenorrhœa and during the long winter night menstruation is even completely suppressed,<sup>1</sup> while according to Holmgren and Gyllenkreutz<sup>2</sup> the oxy-hæmoglobin band in the blood of these subjects showed signs of extension at the close of the long Arctic night.

Light Energy in Relation to Metabolism.—In our study of the action of light energy upon animal organisms it was found that after an initial decline there was an increase in weight of the animals exposed to light as against those kept in darkness and that also tissue change went on more rapidly under the influence of light. This action may be explained by a stimulation of the nervous system, which in its reaction stimulates other vital functions, or it may be a direct action upon the blood stream itself. Of the fact that certain modifications in the tissue change in both men and animals take place under the influence of light energy, there is no question. This action must be twofold, i.e., upon the blood directly and indirectly through the nerve system.

There are certain observations based upon experimental work which seem to favor the theory of a stimulating action upon the nervous system. Quincke<sup>3</sup> demonstrated by his experiments that various tissue cells, pus, blood, muscle, kidneys, liver, etc., absorbed more oxygen in the light than in the dark. So long as they are not quite dead severed muscles and nerves according to Moleschott and Fubini<sup>4</sup> eliminate carbonic acid more freely in the light than in the dark.

That light energy influences the oxidation of the tissues

<sup>1</sup>Quoted from Strebél, *Die Verwendung des Lichtes in der Therapie*, p. 8.

<sup>2</sup>Quoted from Gebhard and Moeller by Freund.

<sup>3</sup>Pflüger's Archives, 1894, Vol. LVII., p. 134.

<sup>4</sup>Quoted by Freund.



is the consensus of opinion and the author believes that this is largely due to a direct action upon the blood itself. Ultra-violet and blue-violet frequencies are absorbed by the blood better than by any other tissue. Physically it seems quite possible that the ultra-violet frequencies are in step or tune, so to speak, with the vibrational activity of the oxygen atom, in other words that there is a sympathetic resonance between them.

The observations of many experimenters on many different occasions tend to show that on both men and animals light energy has an influence tending to increase the oxygenating power of the blood and the oxidation of the tissues.

Moleschott,<sup>1</sup> Selmi and Piacentini<sup>2</sup> found that dogs, hens, pigeons and frogs eliminated less carbonic acid in the dark than in the light. According to Moleschott, the amount of the carbonic acid eliminated is in direct ratio to the intensity of the light. Still further it has been observed that with frogs and toads the blue frequencies of the spectrum are most effective in increasing the amount of carbonic acid given off, while with birds and rodents, the red frequencies had the most influence. This was observed by Pott.<sup>3</sup> Van Pech<sup>3</sup> found that beetles (*Brunchus Pisi*) consume more oxygen in light than in the dark. Scharling,<sup>3</sup> Pettenkofer and Voit,<sup>3</sup> also Fubini and Ronchi,<sup>3</sup> have proved that human beings give off less carbonic acid in the night hours than in the day, even with absolute rest in the last instance. Fubini and Ronchi confined their researches to a single limb, forearm and hand.

As against these observed facts are the statements of Brown-Sequard, Pflüger and others,<sup>3</sup> who believe the increased elimination of carbonic acid is very apparent and occasioned by the movement and enlargement of the muscle under the influence of light energy.

---

<sup>1</sup>Wiener Med. Wochenschrift, 1885, No. 43.

<sup>2</sup>Rendi conti del Reale Istituto Lombard di Sc. E. lettre, 1870, Vol. III., Ser. II., p. 51, ref. Allg. Med. Centr. Ztg., 1872, p. 810.

<sup>3</sup>Quoted by Freund.

It was found by S. Goodnew<sup>1</sup> that persons and animals to whom daylight was accessible excreted more urine, urea and chlorides than those who stayed long in the dark. This is substantiated in the author's clinical experience.

It has been proven by Moleschott, Bechard, Selmi and Piacentini, Pott, Pflüger and von Platten<sup>2</sup> that under the influence of light, through stimulation of the retina, marked elimination of carbonic acid and consumption of oxygen took place.

There is also observed from experiments upon animals which have been deprived not only of eyes but even of brain and lungs as well, that tissue change may be influenced by reflex action through the skin. Certain of these points as to increased elimination of carbonic acid and tissue change under the influence of light energy have been refuted, but the burden of experimental evidence as well as clinical fact is in favor of an influence upon the former tending to its increased elimination, therefore increased consumption of oxygen and consequent action upon metabolism.

According to the observations of Graffenberger<sup>3</sup> and others among them, Bidder and Schmidt, the metabolism of carbon compounds is lessened in the dark, and more fat is formed and deposited. Animals kept in the dark, geese, for example, while being fattened, increase in weight. As tissue change goes on more rapidly under the influence of light energy this is what should be expected, viz., a retardation of metabolism. Because of this fact starving animals, men even who are deprived of food by the exigencies of life, exist longer if they may remain quiet in the dark. In the absence of normal metabolic change, the reserve nutrient supply is not consumed so rapidly as in light. Fat is a product of imperfect oxidation. This physiological fact taken in connection with the preceding observed facts as to

---

<sup>1</sup>Zur Lehre v. d. Einfluss d. Sonnenlichtes auf die Thiere. Kasan'sche Dissert., 1882.

<sup>2</sup>Archives f. d. ges. Physiol., 1875, XI., pp. 263, 272.

<sup>3</sup>Pflüger's Archives, 1892, Vol. LIII.

the relation of light to tissue change is of utmost importance in its practical application in the treatment of all conditions of imperfect tissue change or metabolism and by no means least of all, its rational use in the treatment of obesity, whether primary or secondary to some disease.

According to Justus Gaule<sup>1</sup> the fatty bodies lying next to the sexual organs in frogs disappear in winter time during the day and are formed again at night. This was observed with blinded frogs as well, showing that the light energy upon the fatty bodies takes place through the skin.

➤ The Influence of Light upon Metabolism.—That there is such an influence is demonstrated by the abundant proof provided in:

(1) The influence of light energy upon the blood itself and the entire circulation.

(2) The influence of light energy upon the tissue elements.

(3) The influence of light energy, i.e., its stimulating effect upon the nervous system, producing increased action of the muscles (Pansini), and movements of the body (Loeb).

(4) The influence of light energy upon the organs of sense, stimulation of the visual organs, thereby increasing directly or reflexly the energy of the functions of the body.

The Influence of the Different Frequencies of the Spectrum upon Assimilation and Disassimilation.—This subject was investigated experimentally by S. Daistch<sup>2</sup> and B. Kogan,<sup>3</sup> who formulated the following conclusions:

(1) Red light weakens the processes of both assimilation and disassimilation; (2) green light stands lower than white, in regard to the accumulation of nitrogen, as well as to qualitative metamorphoses; destructive changes proceed

<sup>1</sup>Centralbl. f. Physiol., 1900, Vol. XIV, p. 25.

<sup>2</sup>Ueber den Einfluss des weissen Lichtes und der verschiedenfarbigen Strahlen auf den Gasaustausch bei Warmblütern. Petersburger Dissert., 1891.

<sup>3</sup>Ueber den Einfluss des weissen (electrischen) Lichtes u. der verschiedenfarbigen Strahlen auf die Stückstoffmetamorphose bei Thieren. Petersburger Dissert., 1894.

more vigorously in green light; (3) yellow and violet light induce the maximum of energy in all the vital processes, more complete metamorphoses prevailing under the influence of violet light; (4) darkness causes a diminution in the exchange of nitrogen in the body and incidentally, diminution in the daily amount of urine.

The Influence of Light Energy upon the Respiration, Pulse, and Temperature.—In clinical work the author has observed an influence upon these functions from exposure of the entire nude body to light energy. For example, in a given case 13 observations of the pulse and temperature were taken, in 11 instances the pulse dropped while its volume was improved in every instance. In each of the 13 observations there was a rise of temperature, ranging from .1 to .8 of a degree. The exposure was made to the energy of a 15-ampère electric arc. This influence has been demonstrated clinically in a large number of instances.

Observations have been made experimentally as to the influence of light upon respiration, pulse and temperature. Féré<sup>1</sup> found in one case that respiration was 19 to the minute in yellow light, 17 in green, and only 15 in red. Under the influence of red light the pulse becomes fuller and slower; in darkness it falls so greatly that the sphygmograph ceases to show oscillation. It was also observed by Goodnew<sup>2</sup> that the number of heart beats and the rate of breathing increased noticeably, while the animals upon which he was experimenting were under the influence of the light.

Under the guidance of W. von Bechterew, Trivus<sup>3</sup> studied the influence of colored light on the pulse of healthy persons. Mosso's plethysmograph was used in the experiments. The subjects were kept as a rule for two hours in a special colored room of the clinical hospital. The plethysmograms were taken at the beginning and at the end of each

---

<sup>1</sup>Dégénéresence et Criminalité, 1888, quoted in Raum.

<sup>2</sup>Loc. cit.

<sup>3</sup>Quoted in Dworetzky and by Freund.

experiment. In most cases colored light was found to depress the pulse, that is, it became less rapid and full. This depressing action was most marked in the violet, least in the red. The action of the other colors correspond with their places in the spectrum, yellow excepted. This had no effect at all, probably because it permitted the passage of all the frequencies above it. It was surmised by Trivus that as every colored light ray formed in itself only one part of the energy of the complex of all the frequencies, or white light, necessary for physiological nerve tone, that colored light must be regarded as a form of light hunger, which produces a certain minus in the chemistry of the animal body. In other words, the effect of any one color may be explained not by its own action, but by the absence of the action of all the rest of the spectrum.

According to Raum, light energy exercises an influence upon the daily fluctuations of temperature conversion of matter and excretion in human organisms, both healthy and sick. It is not only pulse, respiration and temperature which are affected by light baths, but there is secured better functioning of all the organs, with relief from the varied manifestations of impaired function. This influence has extended itself even to habitual constipation.

In the weakening influence of red light upon the process of assimilation and disassimilation is to be found a rational and satisfactory explanation of the intense nerve and mental excitement of workmen compelled to labor in red-lighted photographic rooms, and in the excitement and delirium of smallpox patients.

Nothing exercises a more untoward influence on the nervous system than imperfect metabolic change. The mental excitement, delirium, etc., could be accounted for (1) by the deficient nutrition which would result in consequence of weakened assimilation, and (2) by the toxic effect of the products of imperfect disassimilative processes. On the other hand the stimulating effect of red light may, and probably is, in part, at least due to an action

upon the nerve centres, and from the evidence the author is disposed to believe that it acts primarily upon the sensory cortex, and that the depression of the melancholiac is overcome through the sensory centres.

### The Influence of Light Energy upon the Nervous System.

Introduction.—It has been pointed out from time to time, both in discussing the physics of light and the rationale of its action therapeutically, that chemical action pertains to every frequency of the spectrum, to those of long wave length, and low frequency as well as to those of short wave length and high frequency, and that they were respectively active according to the object upon which they fall. The frequencies are, therefore, thermal, luminous or chemical, according to the nature of the body upon which they fall.

When light which falls upon a body is absorbed by it, one of the three following results will follow: (1) chemical, (2) thermal, (3) electrical.

In the first instance, as in the action of light upon the blood and living tissues, the result produced by the chemical action is one of conversion by oxidation; in the second there will be no chemical change, but the energy will be converted into heat. This will be shown in absorption phenomena in the case of substances colored with pure spectrum color; in the third the action of the light energy may give rise to electrical phenomena in two ways, by setting up electric currents, and by increasing electric conductivity of insulated substances. In common with the phenomena accompanying all manifestations of energy the course of these phenomena is seldom a simple one, but is complicated by various simultaneous processes of similar kind.

As yet the physiology of light energy as it relates to the living organism is not sufficiently exact to enable us to say just what is the action of all of the different frequencies.

Of this we are certain, viz., that it is the short and high frequencies which chiefly affect most bodies.

In the living organism different tissues and different fluids are differently affected by light, as is evidenced by their various absorption spectra. Blood corpuscles and albuminous substances give different absorption spectra. The energy of radiation is absorbed by the blood corpuscles at different degrees or wave lengths. Certain of the long and slow frequencies are absorbed, also the short and high frequencies of the blue and ultra-violet. Albuminous substances, however, absorb the short high frequencies almost exclusively.

From a study of the absorption spectra of animal organic substances as well as the physiological effects upon the organism, their ability to react readily to the influence of light is clearly evidenced.

The Action of Light Energy in Producing Motor Excitation.—Exposure to the action of light gives rise physiologically to movements by reflex as well as by direct action on the tissues of animals. Upon exposure of the eye to the energy of the green region of the spectrum, Dogel and Jegorow<sup>1</sup> found that the circulation of the blood both in men and in dogs was very markedly changed by the irritation.

P. Bert<sup>2</sup> found that a chameleon, blinded in one eye became paler in color on the whole corresponding side of the body. That the color of the skin is acted upon reflexly by light energy is also proved in other animals, the octopus, for example. A reflex action by means of the skin and eye thus affects the change of matter.

The Action of Light Energy in Stimulating Other Nervous Organs.—It is a recognized physiological fact that sudden exposure to bright light will excite violet sneezing.<sup>3</sup>

---

<sup>1</sup>Quoted from Dworetzky's *Ref. Zeitschrift f. diät. u. Physik., Ther.*, Vol. V., p. 165, by Freund.

<sup>2</sup>Quoted by Freund.

<sup>3</sup>Landois and Stirling—*Text-book Human Physiology*.

This phenomenon is without doubt due to an action upon the sensory fibers of the trigeminus distributed to the conjunctiva. If the eyes are tightly closed, despite the fact that the red frequencies filter through the translucent eyelid, the disposition to sneeze disappears. This shows that it is the chemical energy of light which acts as an irritant, for upon opening the eyes, the inclination to sneeze is felt at once, which is followed by actual sneezing. The secretion of tears may also be excited reflexly by strong stimulation of the retina by light. This comes through a stimulation of the first and second branches of the trigeminus, and through all the sensory cranial nerves (Dentschenko).<sup>1</sup>

The Influence of Colored Light upon the Nervous System.—It has long been a matter of common observation that different colors produce definite effects upon the senses and feelings. And it is also evident from many biological facts that light has a powerful influence upon the nervous system and the organs of sense.

• Red is always spoken of as a warm color, blue as a cold color, yellow as a cheerful color, green as a restful color, etc. There is a difference in the way that different people are affected by color; one is pleasantly impressed by a certain color, another is the reverse. This indicates a reflex effect upon the nerves. Some are in tune with certain frequencies, others with certain other frequencies, pointing to an inherent difference in constitution, so to speak. The effect of light energy is not only seen in the action upon the nervous organs, but upon the mental state as well. There are also many phenomena and modifications of vital functions which arise from its indirect action.

In the "Undecaying radiance of the sun man takes great delight." There is no natural phenomenon which produces so profound an effect upon the mind of man and his consciousness as light.

"The royal sun feedeth all," but it is not only physical food but mental as well. Under the transition from dark-

<sup>1</sup>Landois and Stirling: Text-book Human Physiology.



ness to light the stimulation of the mental power is greater than from any other form of energy. The withdrawal of this stimulus or reversion to darkness has the opposite effect.

Buedingen<sup>1</sup> from his experiments concluded that the reflex irritability of the spinal cord is not influenced by light rays falling on the skin. These experiments were made to solve the question whether light acts directly on muscle or through the motor nerves, when applied to the nerve muscle preparation. These experiments show that light as applied in the form of sudden transition from darkness to a blue or red light in concentrated form had no direct influence on nerve-muscle preparations made from frogs and further that it was not able to modify contractions caused by their stimuli.

He also made experiments with animals whose cerebri had been removed and in whom the nerve connection between brain and spinal cord had been severed to determine whether reflex movements can be established by the action of light energy upon the skin. From exposure to the concentrated energy of the blue and also of the red frequencies of the arc light spectrum, not the slightest trace of reflex irritability was observed. The experiments of Finsen show that ultra-violet rays act as a vigorous irritant to the nerve system and that by them skin reflexes are increased. From the nature of their action upon the skin (chemical) such an increase of the activity of skin reflexes and irritation of the nerve system would rationally follow.

Schmidt, Rampler, and Ponct are quoted as authorities for the statement that psychical disturbances even to actual delirium have been observed in the eye hospitals where patients have been forced to live for a long time in the dark. Cases of different psychoses, following operations upon the eyes, are recorded by Frankt-Hochwart, Landersberg and Elschning.<sup>2</sup> Numerous experiments were made by the phy-

<sup>1</sup>Zeitschrift diät. und Physik. Therapie, Vol. VI., bk. 5, p. 272.

<sup>2</sup>Quoted by Pansini.

siologist de Parville<sup>1</sup> with the different parts of the spectrum. These experiments, referred to constantly in the literature of photobiology, convincingly show that the red frequencies act as excitants to the nerves. The recent experiments of Pansini point in the same direction. De Parville's experiments demonstrated a calming effect from the other end of the spectrum, attributed to the green, blue and violet frequencies. Another physiologist<sup>2</sup> has produced sensations of faintness by exposure to red light and afterward the symptoms have been removed by exposure to the conjoined red and green frequencies.

In a large photographic plate manufactory, it was noted that a change of color in the light of the workroom from red to green acted to materially modify the excitability of the workmen. They were singularly lively over their work, singing, arguing loudly and gesticulating vehemently. They became much quieter after the change.

Goethe in his "Farbenlehre" or in his "Theory of Colors"<sup>3</sup> called attention to the connection between colors and certain emotions. He observed that red and yellow light energy exercised a bracing effect, while green and blue were depressing. The observations of Baron Reichenbach<sup>4</sup> were to the same effect.

Akopenko,<sup>5</sup> who worked in the laboratory of Bechtrew, proved that the duration of psychical processes is unquestionably affected by the energy of the different parts of the spectrum. A more invigorating and stimulating effect is noted from the effects of the colors nearest to the heat rays. The mood of the person under observation is affected; in red light he feels brisk and cheerful, inclined to move and

<sup>1</sup>J. P. T., Dec. 15, 1900. Taken from Pharmaceutical Journal, no date given.

<sup>2</sup>Journal of Phys. Ther., Dec. 15, 1900.

<sup>3</sup>The student will find Tyndall's ("New Fragments") analysis of this work of Goethe, of interest, showing the misapplication of physical principles by that author but his richness in facts.

<sup>4</sup>Quoted by Freund.

<sup>5</sup>Quoted from Dworetzky's Refer. Zeitschr. f. diät. u. phys. Th., Vol. V., p. 165, by Freund.

act. Physical effects are noted; for example, at the close of the sitting headache has sometimes disappeared. Yellow light comports itself like daylight. It has no special effect on the quickness of physical reaction nor on the temperament. The shorter and higher frequencies from the green up have a depressing effect. A prolonged sojourn in a room with green light, which at first is pleasant, becomes later on very oppressive. Psychical processes are retarded under its influence, mental quietude results, movement is checked and excitement allayed. The effect of violet light is still more depressing. The mental attitude becomes dreamy, even melancholy; after some time headache is experienced. The psychical processes become very slow and are checked, while the feeling of general depression becomes almost unendurable.

### **The Influence of the Red and Blue Frequencies of Light upon the Excitability of the Cerebral Cortex.**

Introduction.—The recent experiments of Raffaele Pansini<sup>1</sup> upon the electric excitability of the cerebral cortex under the influence of light are confirmatory of de Parville's experiments as well as of a considerable amount of biological and clinical observation.

Pansini calls attention to the expression of sadness acquired by those who are blind. There is a sobriety as well as sadness of mien, in contradistinction to the joyousness of mood and alertness of mind, experienced under the influence of the radiant energies of the sun. There is no question as to the influence of sunlight upon the spirit of the individual. Pansini speaks of the cerebral excitation and mental disquietude referred to on a preceding page, produced in those forced to carry on their avocations in a room with red glass in the windows, so extreme that it was necessary to

---

<sup>1</sup>Recherches Experimentale Sur L'Excitabilité Électrique de l'écorce Cérébrale par la Lumière Rouge et La Lumière Bleue, by Raffaele Pansini. *Revue Internationale d'Électrothérapie et de Radiothérapie*, Nov. 1903.

replace the red glass by glass of green coloring. According to the same writer, Courmand reports 4 instances of psychic hyper-excitation in patients with smallpox, who were in a red room. So great was their mental distress that they begged to be taken into the light.

Olenikoff noticed the same condition in smallpox patients of the clinic of Tschistovitsch, who were submitted to the red light treatment. They suffered from delirium with frightful hallucinations, which at once passed away upon their being carried into a light room. In this same connection Pansini called attention to the state of fury or excitement induced in the bull by objects with red coloring. These facts have led to the conclusion that the frequencies of the red region are to be regarded as a dynamic agent, and an excitant to the nervous system in general, but especially to the psychic functions. This view is endorsed by Binet, Féré and Gilles de la Tourette.<sup>1</sup>

According to them the nerves are also strengthened by the energy from the red region.

Pansini's Experiments.—By his experiments conducted at the Institute of Physiology of the Royal University of Naples, R. Pansini has attempted an elucidation of the problem. He endeavored to study the modification of electrical excitability under the influence of (1) blue light, (2) red light. To this end dogs were selected and trepanned in order that the motor area or sigmoid convolution of the cerebral cortex could be exposed to the action of the light. The electrical tests were made both before and after exposure to the different light energies. Pansini does not regard the number of his experiments as sufficient from which to draw definite conclusions, but presents in his report the more important effects noted. The greatest care was taken in the technical management of his work to prevent any error which might have falsified the result of his researches. Very feeble currents were employed at not too frequent intervals, and an

---

<sup>1</sup>L'Année Électrique, 1901, p. 368.

equal pressure of contact in the different tests applied. In addition a long period of repose was permitted each time that the animals presented an approach to an epileptiform convulsion from the stimulating action of the magneto induced ("*electro-faradic*") current. Care was also taken not to permit the slightest elevation of temperature in the tissues influenced by the colored lamps, while the normal excitability was carefully guarded. Pansini in estimating the results obtained considered (1) the diverse intensity of the reaction established by the electric stimulant; and (2) the diverse intensity of the stimulant necessary to provoke reactions in the muscular group stimulated. His results in the latter respect were negative, and in a degree contradictory. Twice in 30 observations he had to apply the secondary of a Du Bois Reymond coil to provoke reactions after the influence of the blue light. Two proofs out of 10 he regards as insufficient for formulating the conclusion that blue light renders necessary a greater stimulation to excite the cortex in the same manner, nor was he sure that the reactions were produced from the action of the red light. There was but one instance following the use of the red light, where the reaction extended to 2 centimetres of the secondary; in all the other researches it never reached anything like it. The contrary effect is sometimes produced, rendering it necessary to apply the secondary after the action of the red light, to secure reactions, especially when bandaging the eyes of the animals. From this single instance the conclusion that red light exaggerates the electric excitability of the cortex is at once impossible and unscientific. From exposures to blue light it was found that although the depressing action upon the excitability of the cortex was wanting in part and in others absent entirely, that in the great majority of the observations made, it reduced the reactions of the same brain to a minimum, and that the same brain, both in normal conditions and after exposure to red light, gave epileptiform reactions. Pending the use of the blue light, these reactions were constantly reduced to some simple muscular jerks.

Despite the many possible sources of error, both in valuation and interpretation of the phenomena encountered, the results noted cannot be doubted. The conclusion as to the depressing action of the blue light upon the motor area of the cortex, is not based upon any elastic differences such as the differences between a muscular shock more or less energetic, more or less prolonged, but upon the important phenomena of tetanus and epileptiform attacks. These are absent after the use of the blue light, although present before its use under ordinary conditions and recurring after exposure to the action of red light. Blue light, therefore, Pansini affirms, has the property of reducing to a minimum the reactions of the cortex and also prevents the action of the stimulus which is exercised upon it at one point, from extending to the other motor areas. This, Pansini concludes, seems but rational when the analgesic action of light is considered, and its power to annul sensibility to touch and pain, as shown by his own experiments. Physiologically, it is known that all anæsthetic agents, morphine, ether or chloroform, for example, when applied to the cortex diminish or suppress entirely the excitability of that part. The blue light is thought to act in the same fashion, and from this point of view he regards the effects observed as perfectly explicable. The electric (magneto-induced) excitability is not completely abolished in the majority of instances, therefore it cannot be regarded as establishing a true anæsthesia.

In conditions of mania where it might be supposed that physiological stimulation would increase the excitability of the cortex, the action of blue light seems to produce a transient calm. Because of the great penetration of these frequencies, the brain is undoubtedly affected even through the cranial case (Dobrzansky). Even so the author thinks it entirely within the bounds of physiological action that the action of the chemical frequencies of light upon the peripheral circulation of the overlying tissues of the cranium, may affect the deeper circulation of the brain itself, and that

this may result; so to speak, in securing an unloading of congested areas, or a return to more nearly normal conditions. This is what happens from the action of light on an inflamed joint, for example, not a light thermally active, but a cold light, and the one is to a degree just as reasonable as the other.

When the eyes of the animals experimented upon were carefully bandaged, so as to exclude any possible effect upon the visual organs, there were no modifications whatever in the effects produced by the action of the blue light, which simply substantiates the theory, that the results obtained are due to the penetration of the chemical frequencies and their action on the circulation. This action by reason of anatomical conditions can only be limited in comparison with the action obtained in deep-seated skin lesions. The action of red light seems not so clearly proven, as in the majority of instances, Pansini found that it gave the same reaction as in ordinary conditions. Twice only, when non-existent before, were epileptic convulsions produced under its influence. In numerous other instances, however, much more energetic and more prolonged reactions (so to speak) were produced under its influence, but of exactly the same nature as under ordinary conditions.

Throwing out of consideration the experiments which are of questionable value, there remained but 2 positive proofs of increased excitability of the cerebral cortex under the influence of red light, as against 8 negatives, which Pansini wisely concluded were too few from which to deduce a law as to increased excitability of the cerebral cortex, to electric stimulation under its influence.

It is suggested that the action of red light is not a direct one, but that it is best explained by the way of the visual organs. This theory is in accord with Bellini's observations, and also with a very great deal of clinical observation. Whenever the eyes were bandaged, Pansini found that a much more intense stimulation was required to provoke reaction than was true when they were exposed to the action

of light. One deduction only can be made at this time, from the experimental work done, viz., that red and blue light frankly exert directly opposite effects upon the excitability of the cerebral cortex. Further experimental observations are to be made by Pansini, to more fully elucidate this interesting problem.

In extreme conditions of nerve exhaustion associated with a very considerable anæmia, the author has observed a very great desire on the part of patients to have red fabrics almost exclusively for articles of dress. This was very marked in a woman physician, who had exhausted the supreme nerve centres, motor, vaso-motor, sensory and intellectual, and who was also profoundly anæmic. During several years of ill health her dress, cloaks and hats were almost exclusively red. There was an intense craving for the color, and none other seemed to satisfy the need, while black, which she had been in the habit of wearing before her illness, produced a feeling of profound depression. With lessened anæmia and an increase of nerve energy, the desire for red fabrics grew less, while with further improvement, characterized by still greater nerve force and disappearance of anæmia, she no longer cares to wear it. But whereas formerly the brain was profoundly anæmic, and the supreme centres well-nigh exhausted, there has superseded a condition of more or less cerebral congestion, aggravated by over-anxiety or application. Since this condition was established there is an aversion to the wearing of red fabrics and red generally because they produce a sensation of distress and discomfort in the cerebrum. This patient had earlier in life suffered from insolation. Her observations are worthy of attention as she approached an analysis of the matter with a specially trained intelligence both in physics and in medicine.

Blue light on the contrary is regarded as exerting a quieting influence upon the cerebral system. In marked contrast to the feelings of joyousness and gayety induced by red light, is the sense of quiet, even sadness, aroused



by violet coloring, which is regarded as the emblem of grief.

In experiments made upon dogs by washing away the cortex cerebri, Goltz<sup>1</sup> found that after a sufficient amount of gray matter had been removed, and the animal had recovered from the immediate effects of the operation that there was established peculiar defects of vision and other sensory defects. There seemed to be established a condition of "psychical blindness." The animal is not blind, can see and use his eyes to avoid obstacles, for example, but seemed to fail to recognize food or flesh as such when placed before him. The following observation is of especial interest in a study of the action of the red frequencies of light upon the cerebral cortex. Goltz caused his servant to dress himself in a mummer's red colored garb, which previously had greatly excited the dog, but after the operation the animal, although not blind, was no longer excited by it. This would seem to indicate that the sensory cortex takes cognizance of these frequencies. In the neurasthenic patient referred to, who clothed herself in red almost entirely, there had been marked congestion of the sensory cortex prior to the extreme exhaustion of all centres, sensory included. There had been no injury as with a traumatism other than insolation, simply a loss of energy with diminished function. The penetration and absorption of frequencies of the red region seemed to supply a needed stimulus. The indications were for exposure to the radiant energies of the sun, but by reason of the necessities of the case and environment, as well as because of the previous insolation there was but one course to pursue, and that involved the spending of the hours other than those demanded by professional duties, very quietly indoors from one month to another. In the dog whose cerebral cortex was washed away, there seemed no response to the periods characterizing the vibrational activity of the red region of the spec-

---

<sup>1</sup>Landois and Stirling.

trum, although vision as vision was intact. This is but one of the many different phenomena which appeared from these experiments of Goltz. It is only instanced here because of a certain evidence which has been accumulated from time to time tending to show that there is some definite relation between this part of the spectrum and the stimulation of the sensory cortex.

Foveau de Courmelles reports an instance of a young man who, upon entering into a violet room, became very sad and began to weep. Insane patients have been at different times exposed to the influence of red and blue light, according to the form of mental disorder.

Ponza (quoted by Pansini) placed a melancholiac of a sombre humor, and with a "taciturn frenzy" in an all red room. After three hours spent there the patient was gay and smiling. On the other hand, a maniacal patient, forced to wear the straight jacket, by reason of his mania, became after an hour and a half spent in a blue room much more calm. Another case of mania after a day spent in a violet room felt himself cured and left the asylum in good condition. Ponza has treated hypochondriasis by red light, mania by blue, while violet light was used for depression of the nerve forces. The editor of the *Inventio Médica*, in Guatemala,<sup>1</sup> is said to have noted the same fact 20 years previously. These experiments first made in Italy were repeated by alienists elsewhere. One of the first to do so was von Paquet in an asylum at Moscow, but his results were entirely negative. Schleger, who made a large number of observations, concluded that the blue light produced a transient calm in only a limited number of maniacal cases. This calm which follows after a short time is of short duration, is not followed by any dangerous consequences, and is proportionate to the intensity of the light.

In somnambulism, Charpignon has found violet light to exercise a quieting influence. In those suffering from

---

<sup>1</sup>Quoted by Freund.

pathological excitement. Uffelmann finds that violet light exercises a quieting influence. More recently Joive has produced in the case of neurotic patients a quieting effect by the influence of violet light; while Denys, availing himself of the great penetrancy of violet light, has tried by means of it to influence the brain of the insane. The researches of Dobrjansky tended to prove their penetration even through the skull.

If it is by the penetration of the chemical frequencies that the condition of sunstroke or insolation is produced, there seems no reason why, in certain cerebral conditions involving over-excitation, there should not be sufficient penetration from exposures to blue light, suitably regulated to favorably influence the mental condition. The mode of action of these frequencies in such conditions, is at the best conjectural. From the fact that the blood and lymph serum are fluorescent bodies, and that the chemical frequencies are absorbed by them, taken in connection with the well-known action of blue light on certain substances other than those contained in the living organism, the author is led to believe that it is by reason of a direct action of the light upon the blood itself; its function as a radiant energy transformer is stimulated. This light energy unquestionably is converted into chemical energy, as is shown by increased oxidation due to an increased storage of oxygen in the red blood corpuscles. Upon the storage of oxygen in the latter, the necessary oxygen saturation of the circulating media depends. In nerve and mental conditions the rôle of toxæmia is one of paramount importance. As a theory of the action of blue light may be admissible until the facts are established, it is suggested that because of the powerful action of the chemical frequencies of light upon the blood, the systemic toxic condition which is reacting upon the supreme nerve centres is overcome through the increased oxidative power of the blood. The selective action in a series of maniacal cases suggests that the cases favorably influenced are those in which the over-excitation or maniacal condition

is purely functional, due to a toxic or an anæmic condition, and that in others not so affected, the mental condition may be due either to an organic change in the supreme nerve centre or the reflex of a morbid condition elsewhere in the body.

There is afforded sufficient foundation for both future photobiological research and clinical observation in the relation of life to light and its action in many manifestations of disease.

Bellini believes that the quieting action of the chemical frequencies of light is induced by the general revulsive effect which it exercises upon the entire superficies of the body. This is undoubtedly, in part at least, due to a direct action upon the peripheral nerve endings, and is an effect of the action of the chemical light energy upon the tissues and their absorption by the blood. The same writer suggests that the action of red light upon the brain is brought about through the eyes and their intimate connection with the brain through the optic nerve. The exciting effects of the red frequencies he believes to be due to their action as a quick stimulant. No suggestion is made as to how they act, but by reason of their long length and infrequent rate, as compared with the chemical frequencies, they have a greater degree of penetration, as is beautifully shown in the transillumination of any part or organ. Foveau de Courmelles<sup>1</sup> regards colored light as an actuality in the treatment of mental alienation. In 1886-87, at the Charity Hospital of Paris, J. Luys<sup>2</sup> showed that hypnotic subjects were sensitive to red as an excitant, and to blue as a depressant. Since 1890, Foveau de Courmelles has made observations at his clinic, showing that the waking state was affected in the same way. To the use of colored light, incandescent, in 1891, he gave the name of "Chromotherapie," the therapeutics of color.

---

<sup>1</sup>Revue Internationale d'Électrothérapie et Radiothérapie Jan., 1904.

<sup>2</sup>Quoted by Foveau de Courmelles.

### The Influence of Light upon Muscular Structures.

The Action of Light Energy in the Stimulation of Striped Muscular Fiber.—It is not known that light has any influence on the movements of striped muscular fiber. A good deal of study and experiment has been made as to the effect of light energy on muscle.

Pansini's experiments seem to show conclusively that the action of chemical light energy increases the power to do muscular work. This would be expected from its action on the blood.

The Action of Light Energy in Stimulating Muscular Work.—Equally interesting and valuable is the work done by Pansini on the biological action of electric light upon muscular action. The results obtained by him, although working in an entirely different manner, tend in the same direction as those of Finsen, Freund, Bernard and Morgan, as well as a host of others, and are corroborative of the opinion held to-day both by the physicist and the physician that it is the chemical rays which have the power to penetrate deeply to awaken reaction in the tissues, and are, therefore, capable of establishing therapeutic effect.

According to Rieger the chemical rays produced motor excitation in the nervous system, while Parville has found that excitations of the peripheral nerves are also produced by them. Gerhard, Pflüger, Cazenave, Ratier, Furie, Fos-sangrève, Aubinois have all demonstrated that light has a direct action on the muscles and nerves. From baths of electric light Colombo found that the chemical radiations exert a stimulating action on all functions of the skin through the bio-chemic action which they awake in the tissues. Because of all these facts, Pansini was led to undertake a series of experiments to find out if blue light could have any biological action upon muscular work. While the fact of muscular excitation by light has been recognized these are the first experiments made to demonstrate its influence upon muscular labor.

Pansini's experiments were made at the Institute of Physiology of the Royal University, Naples,<sup>1</sup> in the dark chamber devoted to phototherapy and with the ergograph of Mosso. The subject chosen for all the experiments was 30 years of age, in perfect health, of normal structure of skeleton and muscles, but little used to muscular labor. Therefore the weight used in all the experiments was but one kilogram. The source of light was furnished by lamps in blue, white, and red glass of 50 candle-power each, and each was provided with a metallic reflector on a universal joint. The time was regulated by a metronome, registering 84 beats a minute. The conditions of the subject were kept the same as far as possible every day. Eight tests a day, in two series of 4 each, were made, an interval of 20 minutes being allowed for rest in the open air between the two series, and also a 5 minutes rest between every two tests. Ergographic tracings, showing exactly the amount of work done by a normal muscle unacted upon by any extraneous influence were first made. Every test made under the influence of light was also accompanied by its ergographic tracing.

As a result of these experiments it was found that (1) blue electric light exerts a favorable action upon muscular work in increasing energy and resistance; (2) that the favorable action upon muscular work is explained by the influence upon the muscles in activity which light exerts upon the muscles themselves; (3) the favorable action is not in every case proportional to the time in which the blue light has acted on the muscles. For example, muscular work is positively increased by exposure to blue light during 15 or 20 minutes, but with longer exposures (an hour) there is a rapid increase of muscular activity which speedily fails. This was beautifully shown in the tracing made after the hour's exposure. (4) The effects of blue

---

<sup>1</sup>L'Action Biologique de la Lumière Électrique, Sur le Travail Musculaire. Par le Dr. R. Pansini. Revue Internationale d'Électrothérapie et de Radiographie, October, 1903.

light upon muscular work diminish in proportion to the time elapsed since the exposure; (5) the action of blue light upon work probably corresponds to the speed of material exchange in the muscles, which are the true organs of motion, since the action of the colors of the spectrum upon nervous excitation is not yet surely proven; (6) action upon muscular work is an attribute of blue light and not that of other colors of the spectrum, since white has no influence, and red depresses rather than stimulates muscular work. Since red depresses muscular work the conclusion is forced that it has no bio-chemic effect upon the blood or muscular structure. It is dynamic and especially addressed to psychic functions.

Pansini's work is accompanied by ergograms, each test showing the effect of blue light, red light, and the absence of effect of white light. These ergograms are most graphic illustrations not only of the number of muscular contractions but of the change in amplitude as well. In the test for control the amount lifted in the first test was 1736 kilograms; in the second, when the muscles had not recovered from the fatigue of the first but 1,455 kilograms. On exposing the arm to a beam of light from the blue lamp the work done for the test with muscles already fatigued by the two tests of control, was 1,848 kilograms, an increase of 112 kilograms over the normal. These experiments have not only a value in demonstrating the power of light upon muscular labor, but are extremely suggestive as well. The depressing influence of red light upon muscular activity, taken in connection with its well-known stimulating effect upon the nervous system, points to an action of the longer slower frequencies either directly or transformed into electric currents, upon the nervous system. The depressing effect of long-continued exposure to the blue frequencies with their well-known vaso-dilatory powers can better be accounted for.

The Influence of Light Energy upon the Functions of Internal Organs.—There are modifications in the functions

of internal organs to be ascribed to both reflex and transferred action of light energy. It is maintained both by Holz knecht and Bie that this is only an indirect action. They reason that as it is the chemically active energy of light which is effective and which is completely absorbed by the organs on the surface of the body, there can be no effect other than a direct one. Holz knecht goes further and states that he regards light treatment of all internal organs as perfectly useless. He asserts that there can be no curative action exercised by light energy below the surface, that there neither is nor ever will be any kind of irradiation available for the cure of deep-seated disease, for any irradiation which is effective deep in the tissues must at the same time destroy the upper layer of the tissue. In this, the author, in common with Freund, from whom Holz knecht's statement is quoted, cannot concur. The penetrant frequencies of light energy have no such destructive action. It is the ultra-violet energy which is largely absorbed in the upper layers of the skin. True, this has a very decided action upon living tissue, but it is an action, so far as demonstrated, which is superficial. With powerful light intensity and long exposures, the penetrant chemical light frequencies, from the blue to the violet, influence favorably the deeper tissues. This is shown in their effect upon the more chronic and deep-seated lupus processes in glandular enlargements and masses of exudate for example, an effect not necessarily accompanied by any destructive action upon the skin itself.

The clinical use of light energy comprising the entire spectrum in systemic conditions, demonstrates that there is an effect due to the longer and slower frequencies. Just what it is, just what the relation between effect and degree of energy is not known, but it unquestionably exists. It is not safe to generalize from a specific action of but one-fifth of the energy of the spectrum on specific tissues, nor for that matter to reach conclusions from a generalization. The frequencies of the spectrum penetrate more and more deeply according to their place therein; the longer and



slower frequencies of the red region penetrating the more superficial tissues completely. If the hand and ear or for that matter tissues of greater depth be exposed to the action of red light, the tissues are transilluminated by it.

That this energy penetrates without doing work seems incomprehensible. True it is the energy that is absorbed which does work, but red light energy must either be absorbed or transformed in the deeper and non-translucent tissues.

Any energy capable of acting upon the skin, as do the chemically effective frequencies, blue, violet and ultra-violet, is an appreciable power. But they do more than that as has been shown in considering the physiological action of light upon the blood. As a green leaf absorbs all the waves except the green which are reflected, and a red rose absorbs all waves but red, even so, then according to physical laws must the red medium of the blood absorb all waves except the red and that absorption means work done, energy imparted, just as in the case of plants.

"The extinction of energy in space or its absorption and consequent disappearance in matter is a deep-seated fact in nature. The appropriation and selection of waves by matter and their eventual return to space constitute the life of the universe, the ebbing and flowing of cosmical tides."

To the author's mind it does not seem that living organisms, showing as they do so close a relation to and dependence upon the radiant energy of the sun, are any exception to the physical laws governing other forms of matter. The blood shows its absorption bands and is fluorescent, the lymph serum is fluorescent also, and it must be that the penetrant frequencies of light energy affect other tissues than the skin, for all energy that is absorbed produces an effect in some way. All the energy of the spectrum is chemical but with a difference. In relation to the skin superficies of the living organism, the higher and shorter frequencies are intensely chemical. May it not be that the longer and slower frequencies, red, green and yellow are chemical in relation to

other structures of the body? The latter are known physically to have a much more powerful effect on certain substances than the shorter and higher frequencies; for example, on dilute solutions of nitro-prusside of sodium with sulphid of ammonia, on green vitriol, on metallic acid and arsenious acid, on sulphuretted hydrogen, sulphid of sodium, on cyanin and on certain plant pigments, chlorophyll, etc. From the action of light energy upon plants, it is very clearly established how important these longer and slower frequencies are for their growth and nutrition.

Speculation is not proof, neither is an absence of evidence. It has been the author's hope that the way might open in the midst of a busy life to help to an elucidation of these questions. Here, however, it is only possible to suggest the possibility of such a biological action and express the hope that careful investigations may be inspired to determine whether or not an exposure of the different tissues of the body to the action of the energy of the various parts of the spectrum is productive of results. The author is convinced that such investigations would neither be negative nor without great value. According to L. Cadmus<sup>1</sup>, the coloring matter in dogs' gall is quickly oxidized, turning green and then losing its color in the presence of oxygen by the action of light.

The serum of horses' blood is subject to the same phenomenon, i.e., it first becomes green and then loses color when it is kept accessible to oxygen with access of light.

That there is then an effect from light energy upon the living organism is shown: (1) By its irritant effect upon the skin, intense light producing inflammation. (2) By its action upon the sweat glands promoting perspiration, this is true of chemical light energy as well as of thermal. (3) By its direct action upon the blood and the blood vessels, dilatation. (4) By exposure of large superficial areas of the body to the action of intense light energy there results an in-

---

<sup>1</sup>Freund.

creased amount of blood in the superficial vessels and a depletion of the internal organs or viscera. (5) By a direct or indirect influence light energy modifies the transmutation of matter. (6) By the action of light energy in relation to motor excitation. (7) By its parasitocidal powers. (8) An excess of light stimulus (in common with too great an expenditure of any energy) is destructive and paralyzing. By it dermatitis, a prolonged erythema with tendency to recurrence and insolation are produced.

## CHAPTER VIII.

Sun Baths. Arrangements of Solaria, Methods of Use and Therapeutic Indications. Tuberculosis of Joints, Pulmonary Tuberculosis, Anæmia, Neurasthenia, etc.

### Sun Baths.

The Chemical Intensity of Sunlight Dependent upon the Season of the Year, Time of Day and Atmospheric Conditions.—Unfortunately the sun's radiant energy is not always available for therapeutic purposes. It is not a matter of dependence upon the weather only, but upon other circumstances which affect the chemical intensity of the light. In considering light sources in their relation to therapeutic work, there must be distinguished the difference between the visual interpretation of light which is its physiological power or optical brightness, and that which is interpreted by its chemical action upon photographic plates, upon bacteria, or in the production of characteristic light erythema of the skin.

The chemical intensity of sunlight does not coincide with its optical brightness. The former varies with the season of the year and the time of day; i.e., with the sun's height in the heavens. There is the summer solstice and the winter solstice to be reckoned with, the morning ascension, the noonday maximum and the afternoon decline. In summer, for example, the chemical action of the sun and the blue light of the sky are much more powerful than in winter. It is weakened in the spring and again in the autumn, reaching the minimum about the 21st of December. It is less in the morning and in the evening than at

midday when the sun is at the zenith. During the height of the summer the hours between 10 A.M. and 5 P.M. are the best. In the winter, however, it is necessary to wait until a later hour in the morning, and to limit the afternoon hours. The atmosphere also affects the chemical intensity of the sunlight as well as its optical intensity. The latter is weakened by about one-fourth during its passage through the atmosphere. There is a much greater loss of chemical energy than optical, and this loss falls most largely upon those frequencies so useful in chemical change, as in agitation of bacteria and in exciting skin erythema, viz., the ultra-violet. They are absorbed in their transit from the sun to the earth.

Solaria or Sun Baths.—“Man lives only by the radiance from the photosphere of the sun.”<sup>1</sup>

In this radiance provided by nature there is available not only for purposes of hygiene and sanitation, but therapeutics as well, the best possible form of light energy. In only one class of therapeutic work can exception be made to this rule, and that is in the treatment of skin lesions, where a concentrated light energy of intense chemical activity is required. That is to be had from the radiant energy of the sun but not at the surface of the earth, as it is absorbed in transit from the sun by the atmosphere. Therefore the electric arc, a radiant sun in miniature which can be used at its source is preferred.

By this solar energy everything within its radius is purified, every object it penetrates is disinfected, and as these pages have abundantly shown, every known form of germ life is either destroyed or its development arrested by the action of light energy. On clear bright days even in the more northern parts of the United States there is to be had a more powerful source of light than can be obtained artificially, while in the more southern parts of the country this radiance is of still greater energy, and, therefore, better

---

<sup>1</sup>E. Larkin: Radiant Energy.

for therapeutic purposes. If the sun had no atmosphere the surface would shine at least two or three times brighter than it does with a blue-violet color, like the light of an electric arc, playing between two carbon terminals.

When the sun is on the meridian, and allowance is made for absorption by air and glass, it illuminates a screen 70,000 times as strongly as a standard candle placed at one metre from the screen. (A standard candle adopted by physicists is made of sperm and burns 120 grains per hour, or 7.776 grams.) The distance of the sun is 150,000 million metres. Square this, multiply the product by 70,000, and the result comes out 1,575,000,000,000,000,000,000,000 candle-power. This is the quantity of light emitted by the sun, and is different from the intensity, for an immense surface, even if not very brilliant, can radiate a large quantity of light, while the quantity of light emitted by any square unit, as a square inch or centimetre, determines the intrinsic brilliancy. A mathematical computation shows that the sun's carbon winding sheet is 190,000 times brighter than the candle flame, and 150 times brighter than a calcium light, and from two to four times more brilliant than the electric arc light, all of which lights appear as dark spots when held between the eye and the sun.<sup>1</sup> In this solar energy is to be found the simplest and most natural method of using light therapeutically.

The sun is only a private in the host of heaven, a single star among millions, but he alone among the countless myriads, is near enough to affect terrestrial affairs in any sensible degree, and his influence upon them is such that it is hard to find the word to name it, it is more than control and dominance. He is almost absolutely in a material sense the prime mover of the whole. To him can be traced directly nearly all the energy involved in all the phenomena, mechanical, chemical or vital. Cut off this energy even for one month and the earth would die, all life upon its surface would cease. This fact has always been more or less dis-

---

<sup>1</sup>Young.

tinctly recognized, but a practical application of its truth is not always made even by the physician, whose duty it is to bring to bear all forms of energy physical and medicinal in the prevention and treatment of disease. The daily detailed application of large and universal truths in nature, too often escapes observation. From earliest times the material supremacy of the sun has always been recognized by thoughtful minds, and for centuries its life-giving powers have received recognition. His royal majesty, the sun, has been made the foundation of religious systems, as with the Persians. Says Young,<sup>1</sup> "It has been reserved for modern times, and to our own century (the twentieth), to show clearly just how, in what sense and how far the sunbeams are the light of earth, and the sun himself the symbol and vicegerent of the Deity. The two doctrines of the correlation of forces and the conservation of energy, having once been distinctly apprehended and formulated, it has been comparatively easy to confirm them by experiments and observation, and then to trace, one by one, to their solar origin the different classes of energy which present themselves in terrestrial phenomena, to show, for instance, how the power of waterfalls is only a transformation of the sun's heat."<sup>2</sup>

Sunshine, though broken in the rill,  
Though turned astray, is sunshine still.<sup>3</sup>

The same thing, continues Young, is true but a little more remotely but just as certainly of the power of steam, of electricity, and even of animals. To-day the thought is familiar, but still the truth is often unheeded.

Whatever work is done, is by the undoing of some previous work.

When we come to inquire for the source of the energy which lifts the water from the sea to the mountain-top, which decomposes the carbonic acid of the atmosphere and

<sup>1</sup>The Sun.

<sup>2</sup>The Sun, Young.

<sup>3</sup>Lallah Rookh, The Fire Worshippers, Moore.

plant-foods of the soil, which builds up the hydrocarbons and other fuels of animal and vegetable tissue, we find it always mainly in the solar rays. Mainly because, of course, the light and heat of the stars, the impact of meteors and the probable slow contraction of the earth are all real sources of energy and contribute their quota, but compared with the energy derived from the sun, their total amount is probably something like the ratio of starlight to sunlight, so small that it is quite clear, as has been said, that "a month's deprivation of the solar energy would involve the utter destruction of all activity upon the earth." It is not only natural, therefore, that modern physical science but medical science as well should make much of the sun. The study of solar phenomena and their relation to health and disease should be pursued with the greatest interest and solar energy turned to account in maintaining the one and combating the other. The beneficent action of this energy was appreciated to the full by the ancient Greeks and Romans with their convenient even luxurious solaria in which they could expose their nude bodies to its action. The lessons they learned from their practical experience should have remained with us to our profit.

The Construction of Solaria or Sun Baths.—These may be elaborate and expensive or very simple and inexpensive. Wherever and whenever the sun shines and there is to be had a few cubic feet of space, whether within or without doors, there is the means to the end. An upper room no matter how small may be utilized and the light permitted to fall in through an open window or in colder weather through the glass of the window. A more pretentious sun room can be constructed with glass for its roof as well as for the sides. arranged as in a photographer's gallery. In either event there should be provided, according to the case, the means of reclining or of walking about, with the nude body exposed to the action of solar light energy. Verandas can also be utilized in similar fashion. If a glass enclosure is not possible, screens of sufficient length may be used. The light



should fall perpendicularly upon the exposed superficies. Where the flat roof of a house offers a suitable resting place for a small roofless cabinet, an ideal sun bath may be constructed. In the small areas back of city houses a similar opportunity is offered. In them a roofless cabinet or a roofless tent will suffice. The interior can be provided with an easy chair, a couch or, if the patient's condition requires exercise at the same time, there is nothing needed but the tent enclosing walls. These should be high enough to secure the necessary seclusion from observation. Large yards may be arranged for solaria by surrounding them with high and continuously boarded fences. The interior can be arranged for all classes of cases, those requiring repose as well as those requiring exercise. These sun yards as well as sun rooms should be provided with the means of suitable hydriatic applications. If sun baths are administered in the room of a house or on the roof or yard of the same, the bathroom facilities will suffice. In more ambitious sun rooms or sun yards in connection with sanitariums, these facilities as well as provisions for massage and an alcohol rub, should form a part of the equipment. There are comparatively few sick rooms, taking the country as a whole, which cannot be converted into a comfortable sun room at some time between the hours of 9 A.M. and 3 P.M., when the sun's energy is most effective. To this end the bed or a cot can be placed directly before the window from which the sash has been removed and the patient placed thereon with the entire nude body exposed. If too cold to permit of the removal of the sash, the exposure may be made to the light after passing through the glass. Luckily there is but little loss here of the short and high frequencies or the ultra-violet because they have already been absorbed by the atmosphere. The sun's energy, with its complex of frequencies, its richness of those of the blue region, can be used by every practitioner in his daily rounds to the good of his patients, and when to the influence of light there can be added that of the air greater good will follow.

It is a simple matter for example in the dressing of a wound, of an open malignant process, where the patient lies in bed in a beautifully sunlit room, to direct that the bed should be moved into the sunlight and the one or the other exposed to the action of the sun's radiant energy not only during the process of dressing but at other times as well. The action may be limited to the visible chemical frequencies only if for any reason the thermal energy is undesirable by placing either panes of blue glass in the window or permitting a blue glass screen to intervene between the patient and the window. To illustrate: The author was recently called in consultation to a patient who for over three years had an extensive open sore as the result of the removal of a cancerous breast by means of pastes. The sore had never healed, and the condition had been aggravated by daily exposures for almost one and a half years to the X ray. The patient's skin was tanned until it resembled a negro's on the entire right side of the thorax from the clavicle far below a line drawn from the sternum and extending under the arm and far down the posterior thoracic walls. There was a large cavity in the axilla, the right arm was enormously swollen, metastases had taken place in the left breast, the discharge was foul and the patient was worn with the pain of this extensive destructive lesion. The attending physician wished to know if the use of light energy would render life any more tolerable and wished the writer to advise as to a practical form of apparatus for the purpose. A considerable experience with the most desperate of inoperable pelvic cases, in which light was used as an adjunct to the X ray, had justified the opinion that by its use, (1) the pain and discomfort would be modified, (2) the odor controlled and (3) a bare possibility of stimulating the healing process.

Immediately upon entering the patient's room, the author was struck with the ease and facility with which the lesions could be kept for from 3 to 4 hours daily under the direct influence of solar energy, instead of being carefully secluded in the dark by interminable dressings. The

windows were west and large, the river lay just below to serve as a mirror for the reflection of the waves of light.

Baradat<sup>1</sup> recommends the giving of sun baths upon the sea, where the light is reflected by a vast mirror—the waves. This reflection of light by the waves of the ocean is an important factor in the good results obtained from sending tuberculous patients to certain seaside resorts noted for their efficacy, as at Mentone on the Mediterranean. The conditions for exposure to solar energy were ideal and the instance is related here that the reader may see and avail himself of every similar opportunity. The most powerful agents in our possession for the inhibition and destruction of micro-organisms are sunlight, fresh air and abundant nourishment. These were all provided in abundance, the latter was the first consideration and the saving clause in the case was the patient's good appetite, digestion and nutrition. The sunlight was at hand and was a factor in the well-being of the patient from its general diffusion in the room, but the concentration of its energy upon the sore itself, despite the well-known fact that open wounds do better than those that are shut in, had never been thought of. Thus every day we ignore the simple means to the end in our desire to reach out after the new and little known.

Willard,<sup>2</sup> in considering sunshine vs. X rays in the treatment of tuberculosis, says: "In my own hospital wards I have always considered the sun porch as the most important of all the means of cure. Every tubercular joint confined to bed, either with horizontal extension or with fixation or traction of joint, spends the entire day at all seasons lying directly in the sunshine, his eyes and head being protected by a green shade attached to the head of the bed. The effect on health, appetite and cell resistance is simply marvellous. When able to walk about, patients are encouraged to play in the sunshine, not in the shade. I have not infrequently

---

<sup>1</sup>Zeitschr. für Tuberculose und Heilstättenwesen, 1903, Bd. V. Heft I.

<sup>2</sup>Journal of the American Med. Ass., July 18, 1903.

sent out into the sunlight and fresh air apparently hopeless cases of joint disease with lardaceous organs, and have had them return with sinuses healed, waxy changes arrested and health restored. Of course, it is necessary that surrounding conditions, even in the country, shall be healthful, since many farmhouses are unsanitary in the extreme. In the treatment of tuberculosis of the joints not only are mechanical and operative measures necessary, but all the accessory conditions of health are essential: a superabundance of easily digested and nutritious food, and clothing adapted to the surrounding conditions, in addition to the sunshine and air. There are few individuals who have not observed the influence of darkness and poverty and vice on the general health, and yet few physicians realize the importance of securing the brighter and better conditions. The time is near at hand when sanatoria for the treatment of tuberculosis of the hard parts, as well as those of the soft tissues, will be established. Outdoor life in tents, either in the pine forests or in the hospital grounds, promises a simple practical application of the principles enumerated. Cheeks will grow more rosy, flesh will increase, energy will improve, and resistive power will speedily be such as to control and overcome the tubercle-bacilli.

“McKenzie and Galloway<sup>1</sup> have also adopted this most excellent principle of treating cases of tuberculosis of joints in the open air by having them live in tents, thus giving patients all the advantages of sunshine and fresh air that are now in vogue in the lung tuberculosis sanatoria. The appetite is greatly improved under such conditions; more food is taken, and it is better digested.

“Dr. Flick’s regulations at the White Haven sanatorium for consumptives are just as applicable to joint tuberculosis as to phthisis cases; patients to live in tents and to spend their life absolutely out of doors, air to circulate freely through sleeping apartments, ample bed covering to be sup-

---

<sup>1</sup>Trans. Amer. Orthopædic Ass., XV., 1902, p. 10.

plied. Each patient to take at least 3 quarts of milk and 6 eggs a day; more if possible. In addition, a good dinner in the middle of the day, and a light breakfast and supper. Dinner of roast beef, vegetables and dessert. The gain or loss in weight are the best indications for adaptation of treatment and food.

“Poncet, of Lyons, and Perdu and Blanc<sup>1</sup> have also applied the method practically by exposing joints covered with iodoform gauze to the direct action of the sun for hours in the day. As the case recorded by them, however, had had a previous excision of the knee, the report only shows that the sun's rays acted helpfully in the cure.”

There are to be obtained distinct effects from the use of sun baths: (1) A tonic effect; to this end a short exposure of the entire nude body to the solar energy is required. (2) An eliminative effect; a prolonged exposure without any attempt to minimize the thermal energy. (3) A nutritive effect; a prolonged exposure modifying the temperature in order to secure the action of the chemical energy where it is desirable to profoundly influence the nutrition of the deeper tissues.

The latter is the method chiefly used by Finsen in his sun baths. The patients promenade naked in a sunlit yard, where everything is done to keep down the temperature of the skin. To secure this result the ground is frequently sprinkled or if necessary shower baths are used. Here the purpose is not to have a thermal effect but a chemical one only. By the penetrability of the blue-violet frequencies and their chemical energy they are able to profoundly modify the nutrition of deep-seated tissues and organs. In the passing and repassing of the circulating blood stream during such a sun bath, every drop of blood is brought under the influence of the light and revived. The impartation of energy to the storer of oxygen, the red blood corpuscle, is of first importance.

In the second instance, it is not alone a question of the

---

<sup>1</sup>*Annales de Chirurgie et d'Orthopédie*, Vol. XIII., 1900, p. 19.

chemical action of the penetrable blue-violet frequencies, although these are still active, but of the thermal as well, emphasizing the effect of the chemical energy upon the skin. An active condition of the sweat glands is induced by their combined action, which, however, may be brought about by either the one or the other alone. A slight perspiration is induced in the electric arc bath, always noticed in the palms of the hands and over the sternal region first. This is never a warm bath. When the sun's heat or heat from other sources is used extreme sudation is established. The use of sun baths in this way is indicated in all conditions where an eliminative effect is desired primarily, as in obesity for example. In the first instance it is the tonic stimulating effect of the sun's light which is desired, and this is usually in a class of cases who are unable to bear an undue expenditure of energy of any sort. Under this head may come convalescent patients, who are still too feeble to withstand this mighty energy. A longer exposure than 3 to 5 minutes in very feeble patients may produce headache, lassitude, insomnia and depression.

Light and Air Baths.—When the baths are administered in the open air, the action is due to the conjoined influence of light and air. These should be administered with little or no clothing for a period of from 2 to 6 hours. To keep themselves warm patients should do some manual work, engage in gymnastics, or have massage. These baths should be taken morning and evening, with a sun bath or hot bath at midday. The effective factors with these baths are regarded as the thermal stimulus, the increased activity of the skin through the radiation of heat and the influence of light on metabolism. The same factors are operative in prolonged sun baths in the open air where no effort is made to eliminate the thermally active energy.

They are practically the same as considered under the second subdivision, save that the purpose of the latter may be obtained within doors. A light and air bath acts as a general tonic to the nervous system, they are also very

useful in the treatment of obesity, and are good in congestion of the internal organs. The action of the heart and the kidneys is stimulated by them. They have been likened in their effects to those of the water cure.

Physiologic Action of Sun Baths.—Under this head must be included all those physiologic changes which have been discussed under the physiologic action of light. It is an influence due not to a single frequency or group of frequencies but to a complex of all the frequencies of the spectrum. These frequencies are thermal, luminous and chemical in relation to the different structures of the body, producing, therefore, the reaction due to their combined influence. Thermal energy gives rise to an increase in the bodily temperature. This is also true, but to a less degree, of the chemically active energy. The thermal effects then produced are practically the same as those induced by other sources of heat, save that they are unaccompanied by the depressing effects so often experienced by the use of hot air, water or vapor. This is by reason of the chemically active light energy conjointly active with the thermal. The thermic reaction stimulates the heart, brain and other organs, and there is an increase in metabolic activity as well. This elevation of temperature may rise to  $40^{\circ}\text{C.}$ ,  $104^{\circ}\text{F.}$  Kellogg found that there was an increased production of carbonic acid, indicative of an increased consumption of hydrocarbon and carbohydrates, which occurs also when the body is exposed to cold. There is likewise an increased oxidation of proteid, a characteristic effect of all the measures which raises the temperature of the blood. From the thermic stimulation there results a dilatation of the cutaneous blood-vessels (evanescent as compared with the dilatation produced by chemical light energy). This in connection with the more energetic action of the heart, the quickened circulation, tends to accelerate metabolism throughout the entire body. The violent and prolonged hyperæmia of the skin induces a determination of blood from the internal organs. By the overfilling of the cuta-

neous vessels a considerable amount of blood is diverted from the interior of the body, since when filled, the vessels of the skin may contain one-half to two-thirds of the entire amount of blood within the body. Naturally a draining of all the viscera results, establishing thereby a collateral anæmia in the brain, liver, kidneys, stomach, spleen, and other viscera. The drowsiness which ensues is a manifestation of cerebral anæmia. Because of this, the patient often falls into a profound slumber. By the thermally active energy of the sun a profound effect is produced upon the nervous system. This is also true of the chemically active energy, and the one or the other is the more active according to the manner of administration of the sun bath. Simultaneously through the influence of the thermally active energy the sweat glands are stimulated to greater activity and very active perspiration is induced. The amount of sweat may be increased from the normal of  $2\frac{1}{2}$  ounces in an hour to as much as 2 or 3 pounds, even more in an hour, especially if the patient is exercising actively.

The action of the chemically active light energy upon the peripheral nerve endings also exerts an influence upon the sweat glands. The effects obtained may be the one of three, (1) from a simple tonic action, where the combined energies of the different frequencies of the spectrum are utilized over short periods of time; (2) by subjecting the patient to the influence of the full energy of the sun over comparatively long periods of time; (3) from the influence of the chemically active energy whenever a means is used to keep down the thermal effect, as by cooling the surrounding space, whether a sunlit yard or a sunlit room, by suitable means, sprinkling the ground, refrigeration of the room, ice or liquid air, and by douching the patient with cold water. In the first instance the action is that of a simple tonic, in the second profound eliminative effects, and in the third fundamental nutritive changes are established. Each has its recognized indication in the various conditions of disease, and the one or the other must be prescribed with



the same intelligent skill, basing the prescription upon physical properties, physiological action, and pathological conditions, as in the case of mercury or strychnia. It is not enough to tell a patient to sit or lie in the sun, but the points which have been enumerated must be carefully considered in order that the needs of individual cases shall be met. The sun bath should be given in the fresh air wherever possible. In this way it really becomes a light and air bath, and as such accomplishes a twofold purpose.

Sun baths are of benefit (1) by promoting perspiration. As the result of this action harmful and toxic products are eliminated. (2) By the stimulation of metabolism. (3) By stimulation of the nervous system, and (4) by the direct action of light upon the blood. This primary action upon the blood is after all the fundamental action, and upon it the round of physiologic changes known as increased oxidation depends.

As to the bactericidal action of sunlight under the conditions governing a sun bath, it is not active. This is by reason of the absence of a maximum of ultra-violet energy at the surface of the earth, and also by reason of the little penetrating power of these frequencies. There is, however, an abundance of blue, indigo and violet frequencies, and their bactericidal action is by no means to be disregarded. Still the primary effect in the sun bath, in bactericidal diseases, is not one of bacterial destruction but one of increased physiologic resistance. In this way the balance of power, so to speak, is with the individual and not the bacteria. By establishing normal physiologic conditions of circulation, nutrition and elimination, the influence of microorganisms need no longer be reckoned with. In all conditions of metabolic defect, and especially in conditions characterized by deficient oxidation, sun baths are indicated. Obesity, diabetes, and the alloxuric diathesis are notable examples, and in this class of cases a prolonged exposure to all the radiant energy of the sun is indicated.

The profound autointoxication of the patient suffering from chronic indigestion whose skin is dry, sallow, leathery, evidencing deficient oxidation, will be promptly relieved by the daily administration of sun baths. Under the influence of the sun's thermally and chemically active energy, the skin becomes moist, healthfully colored and smooth in texture because of the increased oxygenating power of the blood from the chemically active frequencies and the elimination of toxic products due to the free sudation established by the thermally active frequencies.

In no conditions is sunlight whenever it can be commanded, of greater avail than in anæmia and chlorosis. By the stimulation imparted to the oxygen-storing capacity of the red blood corpuscle, the entire blood stream is thoroughly oxygenated, even to the remotest part of the organism. Even though but a part of the body is exposed, the circulating medium passes and repasses through the superficial circulation of the part exposed until in a very short exposure, the entire blood stream is brought under the influence of the oxidating light energy. Still better is the result when the entire superficies of the body can be exposed directly to its influence, for to each square inch of surface there is an expenditure of energy, and when this is multiplied by the number of square inches of the body area, the amount of this expenditure is increased a hundred-fold. By its prolonged effect upon the circulation the spasm of cutaneous vessels, which results in chronic visceral congestion, is rapidly relieved. Elimination of toxic material takes place at the same time.

The sun bath is of very great value in the treatment of neurasthenia. When the conditions of season, weather or environment preclude its use, the electric arc bath satisfactorily takes its place. All forms of neuralgia dependent upon impoverished blood and conditions of malnutrition as well as those associated with the rheumatic diathesis are benefited by sun baths. These are mentioned in contradistinction to those neuralgias dependent upon a traumatism or

of central origin. Where the neuralgic pain is due to an injury with the formation of an inflammatory exudate, concentrated electric arc light energy is indicated, if light energy is to be used.

When employed with the proper precautions Kellogg states that sun baths are of great value in myxedema and exophthalmic goitre. The author, personally, has had no experience in treating these conditions in this way. Whenever the condition is one involving the heart, great care must be taken in the administration of all forms of heat. This is true of sun baths in the same class of cases also, and to the end of preventing an untoward effect of the thermal energy upon the weakened organ, ice bags or a cold coil should be placed over the precordium.

Sun baths in common with artificial light baths are useful in Bright's disease and also in other forms of visceral degeneration, cirrhosis of the liver, for example. In these conditions great care must be taken in their administration. Neither too violent nor too prolonged expenditure of radiant energy must be made. The patient must be properly cooled after the bath, the means for that purpose selected according to the individual needs. In these cases, as a rule, the cold water plunge, swimming bath, cold douche even, are unsafe and the indication for a tonic application of cold is best met by friction with a cold mitten, a cold towel rub or a cold wet sheet used in the same way, the temperature of which should not be lower than 60°F. and for no longer than from 10 to 20 seconds. Reaction must be established in the gentlest and safest fashion, in order not to unduly load up weakened organs by the return of the circulating fluid to the interior of the body.

Sun baths are also of value in chronic rheumatism, in rheumatic gout, in tuberculous joint diseases, in tuberculosis, asthma, and also in affections of the skin and mucous membrane. In fact, the range of morbid manifestations in which sun baths are of value is just as wide as the entire range of disease. Seldom are the conditions such, save in

the very crowded centres, that this all-pervading radiant energy may not be utilized for the purposes of hygiene, sanitation and therapeutics.

Technique.—In so far as possible sun baths should be arranged to open to the south. The time of day in the summer may vary from 10 A.M. to 5 P.M. These hours will need to be lengthened in the morning and shortened in the afternoon as the season approaches the winter solstice.

The duration of a single exposure is governed by the object to be obtained as indicated and also by the season of the year, the condition of the atmosphere and the time of the day. The head and eyes should be protected from the direct solar rays by the use of colored glasses and suitable awnings or umbrellas. To this end the head should be protected. Parasols of dark color (black) should be used, or if the condition of the head necessitates greater precautionary measures, cold wet cloths should be applied, covered in turn with some dark fabric or a dark colored umbrella. Should the patient have previously suffered from insolation, the need for care is still greater. Nausea and other unpleasant symptoms may arise through an undue stimulation and over excitation of the brain and central nervous system. If the whole surface of the body is exposed to the direct solar rays, the head should be still further protected. This to avoid any direct action upon the cerebral circulation, as that secured indirectly through the action of the light upon the body circulation is sufficient.

The whole hairy scalp of men and children may be moistened, also the face. The same is advised in women, and where it is undesirable to wet the hair a napkin wrung out of water at a temperature of from 60° to 65° F. should be applied to the face and neck, and this may be supplemented at need by an ice cap to the head. The napkin should be re-wet with cold water if the exposure extends over a minute or two. The necessity for these precautions does not exist after patients have become accustomed to

the bath except in cases which have suffered from sun-stroke.

The entire body should be nude. In sanatoria where common sunlit yards or gymnasiums are used for both sexes at the same time, the need for clothing may be met by the use of bathing attire. If clothing is necessary, it should be white or light colored, as a considerable portion of the light energy will reach the covered portions of the body through the clothing. Feeble patients should preferably recline during the exposure. Vigorous patients, on the other hand, may walk about the outdoor solarium, and, if provided with a gymnasium, engage in light gymnastics or games of some sort. If the purpose be to increase oxidation to as high degree as possible, as in obesity, diabetes and the lithæmic diathesis, active exercise is indicated.

Frequency of Treatment.—The best results are secured by daily exposures, and the duration should be increased from 30 to 60 minutes at least once a day, according to the patient's toleration.

Summary of Direct Effects of Sun Baths.—(1) A more or less pronounced erythematous reaction of the skin, leading to intense pigmentation and desquamation; (2) profuse perspiration; (3) rise in temperature; (4) nervous disturbances in unduly sensitive persons, and a pleasant sense of refreshment and comfort in healthy or less sensitive persons; (5) improvement of appetite; (6) improved spirits, and (7) better sleep. In a word, the general power of assimilation is promoted. In this way the vital energy of the body and its power of resistance to all injurious influences is greatly increased.

Sun Baths Indoors.—When sun baths are given indoors all hangings should be dispensed with, for by the time the light has filtered through them, even white muslin and lace, much of the initial energy is lost. Furthermore, they become dust laden and afford a suitable lodging for micro-organisms.

Direction of the Incident Light.—The light both indoors

and out of doors should preferably fall perpendicularly upon the nude body.

Insomnia forms an indication for the use of carefully graduated cold applications to the head. Care should be taken not to overheat the head during the bath. The beneficial effect of the cold application to the head may be supplemented by the use of a cold spray applied for 10 or 15 seconds to the legs and feet. Each pathologic condition must be suitably met in the after treatment. The cold douche or spray should be neither too intense nor too prolonged in rheumatism, gout and rheumatoid arthritis, for example.

Tubercular patients must be cared for carefully in this regard, and may not necessarily require the use of a cooling application. The systemic condition of the patient and the amount of reaction established by the solar energy must govern the physician's prescription. It may be well in some cases to use a tepid shower or a fan douche, or even the interrupted jet at the beginning of a treatment for the purpose of cooling a patient. For this purpose a temperature of from  $75^{\circ}$  to  $80^{\circ}$  or  $85^{\circ}$ F. may be used, and the duration of the application for from a fraction of a minute to a full minute.

After Treatment.—This should take the form (1) of cooling douches, sprays, local applications or rubs; (2) of exercise. In both instances the object is to promote a healthful reaction. In cases for which an administration of a cold douche is indicated, it should preferably be made to impinge upon the legs, back and liver, care being taken to avoid the precordial region. In cases requiring great care in this particular the patient should preferably be cooled by a rub with a cold wet towel or sheet. The presence of skin eruptions forms a contraindication to friction, nor is it best to use very cold applications. A rain douche at  $85^{\circ}$ F. is recommended. In this class of cases the necessary reaction would better be established by exercise. In the treatment of painful joints, the force of the impinging douche should not

be permitted upon a sensitive part, as the pain will thereby be increased.<sup>1</sup>

Contra-Indications and Precautions.—The sun bath is contraindicated in all febrile disorders, save in cases of pulmonary disease with slight elevation of temperature. Whenever the febrile activity is of a decided character in this class of cases the use of sun baths is contraindicated, however. Or in this same class of cases, if there is no great rise in temperature, they should be limited to the tonic effect only, and to that end exposures of but a few minutes should be made.

When there is a disturbance of the functions of the body giving rise to an increased temperature, it is an easy matter to still further induce increased temperature, therefore the necessity for great care. The skin reaction is more severe in blondes than in brunettes and with the latter measures may be indicated to soothe the inflamed skin. For this purpose dusting with starch, talcum powder, or the use of oxide of zinc ointment may be necessary. If there is much swelling induced, cooling applications in the way of compresses may be indicated. The trouble is avoided as soon as pigmentation of the skin is established.

Conclusions.—The body superficies in part or as a whole, according to the environment of the individual, should be exposed daily to the influence of the radiant energy of the sun. This should be done for the purpose of maintaining normal circulatory, oxidative and eliminative conditions even in health. The custom of many individuals of spending hours of the day during their sojourn at the seashore clad only in scanty bathing attire is a commendable one, from the point of hygiene, however a critical and perverted mind may regard it from a point of taste. Less cumbersome and light-excluding attire at all times and seasons would redound to better health; while too much stress cannot be laid upon the

---

<sup>1</sup>For full directions as to the scientific use of hydropathic measures either alone or in connection with sun or artificial light baths, the reader is recommended to the work of Dr. Simon Baruch on this subject.

necessity for abolishment of curtains, hangings and draperies, no matter how much their presence appeals to the artistic sense.

The exposure of the unprotected head to the sunlight, if the energy be not too great, will not only often prevent the premature falling of the hair, but it will in many cases arrest the trouble. For a number of years it has been the author's custom to direct patients thus troubled to go without their hats during their summer's vacation and even in the city. Especially has this been done for men patients, where treatment has been instituted by means of artificial light in the office. The result has always been good wherever destruction of the hair follicles had not taken place. The good effect is brought about in two ways (1) by the direct action of light upon the skin and (2) by the absence of the accustomed pressure of the hat, interfering as it does with the circulation. The many cases of eczema that recover in the summer only to reappear in the winter when there is less light and the parts are more completely covered, seems to illustrate that in the radiant energy all about us, nature has abundantly provided the means to the end.

Action of Light Energy *vs.* Open Air on Granulating Wounds.—In advocating the open-air treatment of granulating wounds open by day, with dressing at night, the mechanism of this *ærotherapy* is attributed by M. Wagner to the action of the air which excites the epithelial cells; and at the same time, by the desiccation of the wound causing the death of the virulent germs which are found there.

It is stated by M. Romme<sup>1</sup> that M. Bloch has given a different explanation, to wit, that it is the white light of day which invigorates atonic wounds, and which by desiccation, forms a pellicle furnishing a protection against the germs of the air. The author agrees with Bloch in believing that

---

<sup>1</sup>Desiccation by Phototherapy in the Treatment of Granulating Wounds. *Revue Internationale d'Électrothérapie*, Jan., 1904. Abst. from *Presse Medicale*.



it is the energy of light which is effective in facilitating the healing of wounds exposed to its influence.

It is also unquestionably the action of the solar light which has contributed to the good results noted by Abrahams in skin conditions by sea-bathing.

In relating his experience as to the beneficial effects of sea bathing in some forms of skin diseases, Dr. Robert Abrahams<sup>1</sup> attributes the good results to the prolonged immersion in the salt water, the friction caused by the bumping of the waves and the rubbing of the sand against the surface of the skin, thus removing incrustations and impurities and giving freer play to the action of the salt water, and to the drying of the residue of the salt water upon the body by the sun and air. He loses sight completely of the influence of the sunlight and especially the ultra-violet which so far as it exists in sunlight at the earth's surface is more in evidence at the seashore than anywhere else save at high altitudes. Dr. Abrahams tried the effect of sea water confined in a small space indoors on the same class of cases without obtaining any salutary results whatever.

---

<sup>1</sup>New York State Med. Journal, Jan. 1904.

## CHAPTER IX.

Electric Arc Baths. Arrangement of Light Mechanism, Methods of Use and Therapeutic Indications. Pulmonary Tuberculosis, Bronchitis, Bronchial Asthma, Anæmia, Neurasthenia, Locomotor Ataxia and other Nerve Disorders.

### The Electric Arc Bath.

Electric Arc Mechanisms and Methods of Use.—An experience extending over a period of 11 years with the electric arc as a therapeutic agent, both in private and clinical practice, has established beyond question the writer's confidence in its value. During this time it has been in almost daily use. Important as the rôle of light energy is in relation to skin pathology, it is by no means confined to it. It has a place in general medicine of equal if not greater importance. A description of the apparatus and some of the results obtained have been embodied in a report on "Electric Light as a Diagnostic and Therapeutic Agent,"<sup>1</sup> and "The Electric Arc Bath,"<sup>2</sup> a Clinical Report," as well as in subsequent contributions to current literature. The results obtained in the beginning with a somewhat crude arrangement of an electric arc led to a further elaboration of the apparatus for its application, consisting of the "Cabinet" or "Bath" described in the writer's papers above alluded to, and also by Imbert de la Touche in the *Revue d'Électrothérapie*, April and May, 1896.

---

<sup>1</sup>Translations of the Amer. Electro-Therapeutic, April, 1904. Journal of the American Medical Association, 1895.

<sup>2</sup>Transactions of the American Electro-Therapeutic Association, 1898. N. Y. Medical Journal, Jan. 28 and Feb. 4, 1899. "The Electric Arc Bath," by Margaret A. Cleaves, M.D.

A description not only of this cabinet, but of the various arrangements of arc lamps springing into use, following upon a presentation of the physics of light and especially of the electric arc may help each reader to an elucidation of the question as to the simplest and most advantageous arrangement of electric arc mechanisms for therapeutic purposes, the one capable of securing the best results and, at the same time, of being operated at a minimum of time, energy, and expense. In discussing the subject of light baths, too great care cannot be taken to discriminate as to the character of light used, for only in this way can scientific progress be made and accurate conclusions be reached. The electric arc by reason of its physical properties offers advantages not possessed in the same degree by any other source of light.

In the electric arc there is to be had a miniature sun comparable for therapeutic purposes in every respect to the radiant energy from the sun and for purposes of localization, when tissue reaction is desired as in skin conditions, it is a source of the most intense chemical activity or ultra-violet light, superior to sunlight at the surface of the earth.

When sunlight is obtainable it is to be preferred over any source of artificial light for the therapeutic uses of light energy in general conditions. For, it is not only the radiant energies of the sun which are active, but the fresh air as well. The electric arc whether with carbon, carbon and iron, or iron electrodes only, is very rich in the short high frequencies or ultra-violet frequencies, and therefore is to be preferred where an intensely chemical energy is necessary, as in skin conditions. No matter if the sun is available, the arc is the better source of light energy for skin localization.

For the use of light energy in general medicine, however, the indications are equally well met by means of sunlight. But there are many days in the winter season, especially in all northern climes, when the sun does not shine, when the need of the patient, suffering from anæmia, malnutrition, phthisis, bronchitis, tuberculosis pulmonalis, etc., for sunshine is imperative. This is true of crowded centres, such

as New York, London and Chicago, for example, where by reason of the narrow streets and tall buildings, a considerable proportion of the population are obliged to live in rooms, apartments, houses even, into which the sun never falls, or but to a limited extent. There is no opportunity of flooding their every corner with the sun's energies the whole range of the spectrum active at the surface of the earth, than which no better hygienic or sanitary influence exists.

These conditions are not only true of the extremely poor, but of people in comfortable circumstances as well, in the larger cities. There are also from five to six months of the year when the sun is obscured often and for days at a time. During these periods every one suffers from the lack of its beneficent influence and conditions are engendered unfavorable to health. But the loss, though temporary, of radiant energy, falls most severely upon those who are handicapped by disease. Therefore radiant energy baths should be the logical outcome of this need, and form a part of the equipment of the physician, who by every rational means in his power endeavors not only to combat, but to prevent disease. The electric arc as an artificial source of radiant energy is available over a considerable extent of the country by reason of the fact that it is very extensively used for the purposes of street illumination. It is not difficult of manipulation, and cabinets or rooms for its use are easily and comparatively inexpensively constructed.

Physically, the arc, as has been stated, is comparable to the sun as a source of energy. Unlike the incandescent light bath, it is not a heat bath. In fact, the heating effect is subordinate to the chemical effect. The effect of the electric arc bath is not confined to the action of high frequency waves alone, the low frequency waves as well as the ozone which is generated, play an important part in nutritive change. From the administration of an electric arc bath there is obtained an action upon the skin, the patient experiences a pleasant and slightly prickly sensation. There is produced, even from a short exposure, upon the skin of

some patients a slight erythema, while with others there is but little such effect even from long exposures. The face assumes a normal rosy coloring and an appearance of refreshment and repose on emerging from the bath is always observed. From the administration of the electric arc bath the author has noted the establishment of circulatory changes with a uniform regulation of the heart's action, as evidenced by improved volume and slower pulse rate, the augmentation of the temperature, increased activity of the skin, fuller and slower respiration, gradually increased respiratory capacity, and diminished irritability of the mucous membrane in tuberculous, bronchitic or asthmatic patients. There is also lessened discharge in those patients suffering from catarrhal conditions of the nasal passages. In diseases of the respiratory system, a soothing effect upon the mucous membranes is always experienced, while cough and expectoration are diminished.

Finsen<sup>1</sup> first published his observations upon the stimulating action of light in 1895. At the same time he pointed out that the chemical rays might be useful in the treatment of disease. At that time he did not have in mind the use of concentrated light, which has since made his name famous, but the use of general light baths, that is, the exposure of the whole body to the chemical rays of light. These he has also used, and speaks of them always as chemical light baths. By them is to be understood a bath of the same character as first used by the author in 1893, reported to the American Electro-Therapeutic Association in 1894, and in a more perfected form in 1895. A description of this bath with a report of cases treated and results obtained was presented to the American Electro-Therapeutic Association at its eighth annual meeting in Buffalo, 1898, and was published in the Transactions of the same year.

Both reports were also published in the current Medical Journals.

---

<sup>1</sup>Journal of Physical Therapeutics, Oct., 1900. A note on Light Baths, N. R. Finsen.

Chemical light baths have a very decided action upon the skin. This was indicated by the results obtained from the use of the electric arc bath in the author's experience, but it has been fully established by the experimental work of Finsen.

The dilatation of the capillaries and blood vessels of the skin by the action of the chemical frequencies is not an altogether acute or rapid process, but is one of long duration. By reason, therefore, of a light bath there is established a dilatation of the cutaneous vessels, which determines a more active supply of blood thereto. This in turn unquestionably influences favorable nutrition, enabling the skin to better perform its function. But this action is not alone confined to the skin. It penetrates farther, and is much more far-reaching in its beneficent influence.

Description of Arc Light Cabinet.—The cabinet used by the author for the past 9 years is 6 feet long,  $2\frac{1}{2}$  feet wide, and 7 feet high, built in the corner of one of the office rooms. It is entirely closed in, save for an observation window, which can also be utilized for the admission of fresh air, if desired. It is lined with zinc throughout in order to prevent any danger of fire from a fragment of burning carbon. This zinc lining is painted white, and finished with white enamel in order to afford the best possible reflecting surface for the light. The lamps, two in number, are suspended one at each end of the cabinet, with a shield of glass directly underneath to prevent particles of carbon falling upon the patient. The light of the arc is projected toward the patient's body by means of reflectors placed back of each arc. These reflectors or mirrors are of glass, silvered at the back and concave. By their use the operator is enabled to direct the beam of light at will upon the part of the body where it is desired to secure the action of the greatest intensity of the light energy.

The cabinet contains an ordinary wire-mattress cot, which is made up as a bed with fresh linen for each patient, and upon which the patient reclines.



Fig. 10.—Electric Arc Cabinet.





In the author's office the current is taken from the Edison incandescent mains at 110 volts pressure, and each lamp takes about 10 ampères at 50 volts, the remainder being consumed in the rheostat.

At the New York Electro-Therapeutic Clinic the lamps were on the Thomson-Houston alternating-current mains of 104 volts, and each lamp took 9 ampères at 48 volts, the remaining 8 volts being consumed in the rheostat.

Both equipments have given satisfaction, but the continuous-current arc lamps have been somewhat less difficult of adjustment, and, therefore, have required less care.<sup>1</sup>

As the patient lies at rest in the bath he is bathed in a flood of light emanating from sources of 4,000 total normal candle-power (the arcs of 2,000 candle-power each). While the patient's entire nude body should be exposed to the action of the light energy, exposures are sometimes made with only a partial undressing. The eyes are protected from the intense light by means of colored glasses, and, if desired, the face and hands may also be protected to prevent the tanning effects of the light or an artificial sunburn.

All patients, but especially phthisical and bronchial patients, are directed to breathe in deeply and fully while lying in the bath.

Practically the same arrangement, copied from the writer's, is in use by physicians in various parts of the United States. It was also copied in all essential points by Imbert de la Touche of Lyons.<sup>2</sup> In an article in the *Revue Internationale d'Électrothérapie*, April and May, 1896, he described the author's cabinet, and also his own modification, which consisted in placing the carbons at an angle, probably 45°. In this way the crater of the positive

---

<sup>1</sup>The ease with which both continuous and alternating current arcs may be operated is a matter of (1) a knowledge of the mechanism and (2) experience in handling them.

<sup>2</sup>A Novel Application in Therapeutics by Imbert de la Touche, France, *Électrophothérapie or Bath by Light*, *Revue Internationale d'Électrothérapie*, April and May, 1896.

carbon served as a reflector enabling him to dispense with the reflector as used by the author, and to secure more of the energy of the *light of the arc proper*. In the author's cabinet but one patient can be treated at a time, and it is not, therefore, so desirable in dispensary practice, where it is necessary to care for a number of patients simultaneously, as a room arranged with one or more powerful arcs, 80 to 100 ampères suspended from the ceiling, and at the same distance from the floor as in the cabinet just described, i.e., 6½ feet.

The size of the room may vary according to the number of patients to be treated, or the facilities at the operator's command. It may be divided by screens or partitions as is necessary, and the couches can be placed radially from the centre, and in an inclined position looking toward the light. This is the arrangement used by Finsen in the administration of electric arc baths, the following description of which is from his pen:<sup>1</sup>

Finsen's Light Baths.—These consist of a circular room about 37 feet (12 metres) across, from the ceiling in which are suspended two powerful arcs, 100 ampères each, at a distance of a little over 5 feet (2 metres) from the floor. The room space is divided by means of partitions extending radially from the centre, which secures the necessary privacy. In the individual small rooms thus obtained, beds are placed in an inclined position. Upon these beds, with the body entirely divested of clothing, the patients lie, exposed to the radiant energies of the arc. These baths, as has been stated, are in no sense heat baths, and as a matter of fact, the temperature is so low that it is necessary to warm the rooms for the comfort of the patients; yet, notwithstanding the lowness of the temperature, the chemical action upon the skin is quite as strong as sunlight. A pleasant warming and tingling of the skin follows their use. The length of exposure varies from 10 minutes to an hour. In the author's

---

<sup>1</sup>Journal Physical Therapeutics, Oct., 1900.

cabinet<sup>1</sup> the exposures are from 15 to 45 minutes. Different patients differ in their susceptibility to the action of the chemical frequencies upon the skin. A very pronounced erythema in the more susceptible subjects may be produced in 10 minutes; in others, there may be only a slight reddening after an hour's exposure.

The electric arc, either in the form of a cabinet bath, or by projecting the beam of light on the part as with the marine searchlight, has given excellent results in the treatment of muscular rheumatism and the different forms of neuritis.

With cots of ordinary height, the distance of the patient from the arc would be the same as in the author's cabinet. i.e., 4 feet. Given lamps of the same electric power, and, therefore, capable of producing the same quantity of light, there will be approximately the same total radiant energy emitted in each instance, i.e., in the small cabinet or the large room, but the energy for each square inch of surface exposed to the light activities will be very much greater in the smaller space, owing to the reflection of light from the walls. Therefore, if the greater expenditure of energy is not desired, lamps of smaller ampèreage can be used which will minimize the expense for current. On the other hand, when indicated by the pathologic condition, the greater intensity per square inch of surface exposed would produce better therapeutic results. From the results obtained there is every reason to believe that two 10-ampère lamps in series would produce sufficient energy for so limited space. There is, however, no objection to using arcs of higher ampèreage if the operator desires, bearing in mind always that the amount of light emitted by the unit area is practically the same. To increase the amount of light emitted, the size of the crater must be increased in order to provide a larger unit of area.

There are also quadrangular cabinets, with the arcs fitted in each corner. In these the patient sits with his head

---

<sup>1</sup>Transactions American Electro-Therapeutic Association, 1898.

outside as in an incandescent bath. Such cabinets are used in Germany, and Freund refers to them as the arc light enclosed bath of Kellogg. The lamp mechanism is so arranged that the light energy can be thrown both upward and downward, and directed upon any part of the patient's body at will. Arrangements are made in these cabinets for the introduction of colored glass filters, according as to whether it is desired to use the visible chemical energy of the arc, blue glass, or to minimize the heat by the use of red glass.

Freund objects to the use of reflectors to intensify the light, on the ground that "burn-blisters" are liable to be formed on the part of the skin to which the concentrated arc light energy falls. The author has had no such trouble with 25-ampère arcs where the energy has been projected upon a part by means of a Mangin mirror. Another objection which he offers, accrediting the thought to Strebel, does not exist in fact, viz., the formation of noxious gaseous compounds (acetylene and other compounds of carbon and hydrogen), which he says are not only absorbed by the skin, but also escaping at the neck opening, may penetrate the patient's air passages. The author has fully considered under the physics of the electric arc the nature of the gases given off by it when in activity, from the physical chemist's point of view. From the investigation of the subject there is nothing to lend color to the thought that such gases generated during the activity of the arc exist in sufficient quantities to exert a deleterious action during the time the patient is exposed to their influence.

The reader is referred in this connection to the chapter on Physics of Light Energy, in which the nature of the gases given off by the active electric arc is fully considered.

The enclosed cabinet described in these pages has been continuously in use for 9 years. Exposures have been made from 15 to 45 minutes in length, to tubercular, asthmatic, bronchial, anæmic, convalescing grippe and bronchopneumonia, neurasthenic, neuritic, etc., patients not only

without bad effect but always with good and with, as has been stated, so immediate and favorable an effect upon cough and expectoration, that it has always been felt that there was effective some form of energy of a powerful oxidizing character other than the light energy. Ozone which from the most careful experiments is shown to be present, but not in large quantities, would produce this effect in respiratory conditions. The nitrous oxide given off in larger quantities does not seem to act deleteriously, nor does it when generated by the disruptive discharge of influence machines as they are used. The air of the rooms occupied by the latter as well as the air of the arc light cabinet, is deliciously pure, having the same odor and freshness as at the seashore or mountain top.

It should be noted, however, that the cabinet described is really a small room with large cubic foot space, and after these years of use, the author has not seen fit to change it in any particular save to lower the lamp mechanism a few inches. The window for ventilation should preferably be placed in the upper part of the enclosing side or end, as the impure air rises. If desired two windows may be provided, a lower one for observation and the ingress of pure air, and the upper one for the escape of impure air. In practice this has not been found necessary. Just here it may be well to say that the upper carbon should be positive, in order that the crater may serve as a reflector and the light energy be directed downward upon the superficies of the body. The placing of the carbons at an angle, as was done by Imbert de la Touche in his modification of the author's cabinet, enables the direction of the maximum light energy to the superficies of the exposed body.

Single arcs of from 10 to 25 ampères are also in use in the offices of physicians throughout the country and the effect of the light energy from these is heightened by the use of parabolic reflectors. In this way the light which would otherwise be radiated upward, is reflected downward upon the patient.

The small enclosed rectangular cabinet described by Kellogg and used in Germany, the author does not advise for arc light baths. The light energy, as well as the other activities of the arc, serves the physician's purpose better when diffused in larger cubic foot area. These cabinets as constructed in Germany are usually a combination of an incandescent and arc light bath, arranged so that the energy of both can be used at will, or either the one or the other separately.

This combination is not advised. The therapeutic indications for the incandescent light bath, which have been fully considered, are different from those of the arc, although they touch at points. But to secure the best results, these cabinets should be constructed on different lines as has been pointed out. This is not possible where one enclosing cabinet serves both purposes.

In the use of these various arrangements the patient occupies a recumbent or sitting position, and is, as has been stated, either wholly or partially divested of clothing.

In the writer's cabinet, and also in the room used by Finsen, beds are provided which make it possible for the patient by reason of the reclining position and protection from currents of air from underneath, to be entirely nude without chill or discomfort. This is not possible in the use of the marine searchlight, for example, unless the beam therefrom be projected into a cabinet, for by reason of the size of the beam and of currents of air only a partial exposure can be made. Nor is it desirable that all the patients for whom these baths are indicated should occupy a sitting position.

It is only necessary to keep in mind the condition of patients for whom treatment by means of an electric arc bath is indicated, to appreciate how essential it is, first, that the entire body be exposed to the action of light, and second, that it be administered so as to minimize the patient's discomfort, and avoid any danger of chill.

But while no better reasons exist than the well-being of

the patient and the exposure of the entire body to the beneficial influence of this bath of radiant energy, there are reasons dependent upon the physical laws governing light why one method of application is better than the other. Scientific progress will be much more rapid and sure if at the outset there can be secured to the physician, who may desire to avail himself of light as a therapeutic measure, an arrangement of lamp mechanisms capable of securing the maximum benefit with the minimum expenditure of time and electric energy.

With the arc suspended above the patient as in the author's cabinet, and also in Finsen's room, where the arc is suspended from the ceiling and couches arranged radially around it, the light falls perpendicularly upon the patient. This is correct according to physical laws. In this way the whole of the crater light and the light of the arc are thrown down upon the patient's nude body, thereby securing an irradiation of the highest chemical activity compatible with the ampère of the arcs used.

The field of usefulness of these artificial light baths energized by electric arcs is as broad as the domain of medicine itself.

In the writer's personal experience the non-concentrated light energy of the carbon electric arc has been found of great value, in both primary and secondary anæmias, malnutrition, neurasthenia, in neuritis and neuralgias, in tuberculosis of the bowels, in sprains and contusions, in eczema, seborrhœic eczema with loss of hair, psoriasis and in acne, as well as in respiratory diseases. In no one condition is it of greater value than in tuberculosis of the lungs.

### **The Electric Arc in Tuberculosis.**

No countries suffer in the same proportion from tuberculosis pulmonalis as the British Isles. This, without doubt, is largely due to the absence of sunshine over prolonged periods of time, an untoward physical condition which is still further contributed to by the fog and dampness. In-

stead of the organism being bathed in sunlight for the most part, there are consecutive weeks and months in which the sun rarely shines. The absence of the sun's rays interferes with all the functions of the economy.

There can be no question but that the living organism is to be regarded as an energy transformer, and under normal conditions it would seem to functionate as a radiant energy transformer as well. By the absence of the complex of wave lengths from the sun, absolutely essential to its well-being, depressed and disordered function obtains. The influence of the chemical frequencies upon the blood stream, and especially upon its oxygenating power, is in abeyance; mal-nutrition results and the micro-organisms find a fit habitat for their development. Especially is this true of the *tuberculosis bacillus*. Patients suffering from tuberculosis are sent where? To a land of sunshine. When a climatic change becomes necessary the place selected, whether by the sea or inland, whether of ordinary or high altitude, is always a place where the sun shines, where for maximum periods of time the patient is under its beneficent influence. Not every patient can avail himself or herself of such a change. It may be absolutely imperative to remain at one's post of duty, wherever that may be, no matter how grave the impending danger. Work and a degree of ill health are not by any means incompatible, and the patient may so order his life as to meet the daily duties and at the same time have the treatment tending to a restoration to the normal.

It is possible in almost every city and village throughout the country, to have the means of subjecting the patient to the action of artificial sunlight, during the season when exposure of the nude body to sunlight is impracticable both because of the cold and the many sunless days of the winter solstice. This lack of sunshine may not only be true of the winter months, but often characterizes long periods of time during the summer solstice as well. During days of wind, damp and cloud, tubercular patients suffer very greatly, and the disease progresses more rapidly.



Climatically Arizona very nearly fulfils these conditions, and, therefore, offers the very best conditions for patients suffering from tuberculosis. The territory is largely an extensive plateau, hundreds of miles from any large body of water, situated between the two greatest ranges of the Rocky Mountains, traversed by mountain ranges and surrounded for several hundreds of miles on every side by sandy deserts. The even temperature and dryness are Arizona's chief claim to merit. The dryness means sunshine—the humidity in the air as reported by the U. S. Weather Bureau at Phoenix was on several occasions in July, 1900, as low as 1%. There is the greatest percentage of sunshine at Phoenix, Arizona, reported by any U. S. Weather Bureau office. In November of 1900 the average daily sunshine for that month was 9 hours, 12 minutes. Davos Platz, prominent in Europe for its sunshine, had but 4 hours and 12 minutes average for the same month. A very noticeable effect of the dry air is the great diminution in the amount of sputum in those cases in which there is excessive bronchial catarrh associated with the tubercular lesion.

This is an atmosphere comparable in temperature, dryness and radiancy to that of an electric arc bath, as was pointed out by the author in 1898,<sup>1</sup> who likened the conditions of the arc light bath to those of a clear dry sunlit day, and these are essential features of a climate for tuberculosis which it would be well to imitate artificially whenever possible.

In an electric arc bath there are no elements of depression, as in exposure to hot air, for it is not a heat bath. It is only gently warmed, and from it there is obtained a sensation of life and vitality. The chemical activities, which are cold, alone act upon tubercular lesions. This is proven by actual clinical observations, not only in tubercular diseases of the skin, but in tuberculosis pulmonalis, thereby showing that they are the effective rates of the vibrational activity

---

<sup>1</sup>The Electric Arc Bath, Am. E. T., Sept., 1898.

or frequencies of light energy. By cold light must always be understood the frequencies of intense chemical activity,—blue, indigo, violet and ultra-violet. In a complex of all the frequencies of the electric arc, also in the ionization of the air by its action and the production of its gases, the author believes that there is to be had a physical condition comparable to sunlight and fresh air. Its use cannot be continued over indefinite periods of time, nor for that matter can the same class of cases be exposed indefinitely to the action of sunlight. Care must be taken in both instances. An exposure to sunlight, and likewise to an arc light, means an expenditure of energy within the tissues, and no mechanism, whether the living organism or a high frequency transformer, for example, can take care of more energy, transform it in other words, than it is built or wound for. If there is too great an expenditure of light energies, either from too intense exposures or over too prolonged periods of time, the organism will suffer.

The opinion appears to be widespread that to use light therapeutically demands expensive apparatus, prolonged exposures, a large staff of nurses and great expense. Willard places the expense of operating a Finsen apparatus at \$3,000 a year, and in the expense finds an objection to the use of light in the treatment of tuberculosis of bones and joints. In other words, the popular impression seems to be that an equipment which excludes all the energies of the arc, save the short and high frequency rates of the chemical end of the spectrum, especially a source very rich in ultra-violet frequencies, is called for.

The prominence given to phototherapy by the brilliant work of Finsen, in lupus vulgaris especially, is no doubt largely responsible for this opinion. But it does not necessarily follow that even in the treatment of lupus vulgaris and other skin lesions, so expensive an outfit initially, nor such tremendous consumption of current is necessary.

A clinical experience with light as a therapeutic measure since 1893, has demonstrated to the writer's satisfaction that

such is not the case in general conditions where applications of light diffused in a cabinet is desired, or in the case of strictly local lesions where concentrated and condensed intensely chemical light energy is indicated.

The value of sunshine in the treatment of tuberculosis, whether of the lungs, bones, joints or glands, and also in bronchitis, asthma, convalescence from grippe and bronchopneumonia, for example, is recognized and utilized just so far as is possible in combating such conditions.

In the electric bath there is to be had all the radiant energy characteristic of sunshine, not only in a more concentrated, and, therefore, more active form, but a spectrum richer in ultra-violet frequencies than sunlight because of the absorption of these in transit from the sun. It is also a source of radiant energy which is available at all times, no matter what the weather conditions.

In the crowded cities where the greatest need exists for radiant energy to meet the needs of tuberculous patients, the electric arc is always available, not only at all seasons, but at all hours of the day or night. Cabinets for this purpose cannot only be equipped but operated at a reasonable expense, and from their use an expenditure of energy similar in physical character to an expenditure of energy of solar light be obtained.

The inhibitory power of sunlight upon the growth of tubercle bacilli was established some years ago. The same is true of electric light. In the laboratory this inhibitory action of electric light is much more powerful than that of sunlight, and in the especially equipped rooms or cabinets in a physician's office this is equally true. The claim is made that this is not true of electric light in practice. No doubt under the latter conditions it is influenced by the arrangement of mechanisms for light administration, the ampèreage, and the method of their employment. This in no sense refers to a destructive action upon the bacilli within the tissues.

With the author, Freund believes that for an effect upon the deeper tissues longer and slower frequencies than the

ultra-violet rays are necessary. Laboratory experiments with the chemically active light energy are made upon plate cultures. In practice, the conditions are different. The bacilli are located deep in the tissues, and the ultra-violet rays must first pass through a relatively thick absorbing layer before they reach the bacteria. To secure such an effect, the intensity of the ultra-violet rays must be very great, the exposure very long, and it is quite within belief that the superficial layers of the skin would be severely injured. The work of Bernard and Morgan<sup>1</sup> seems to have established very conclusively that in bactericidal effect upon plate cultures as well as on the power to excite tissue reaction, the ultra-violet frequencies are the active ones.

That other elements of concentrated light, of larger wave lengths, that is, longer, slower and of greater amplitude, greater penetrancy, and which exert no such injurious effect upon the tissues, have a curative effect is not only easy of belief, and capable of rational demonstration, but has been established clinically.

In such conditions as tuberculosis pulmonalis for example, the indications are not only to be met by an application of concentrated light energy over the lung lesion, but the impoverished blood must be fed, nutrition must be improved and the vital resistance increased. To this end it is necessary that the entire organism should be subjected to the action of light energy. Therefore it is not necessary to concentrate and condense the chemically active energy as in the treatment of a lupus patch or nodule. The indications are best met by distributing all the energy uniformly in the rooms or the cabinets arranged for this purpose and exposing the entire body to all of the energy of the electric arc spectrum just as in the case of a sun bath. In the latter it is recognized that the effective energy is a complex of the frequencies of the solar spectrum. In this way, the more intense chemically active frequencies are able to exercise their

---

<sup>1</sup>The Physical Factors in Phototherapy. J. E. Bernard and H. de R. Morgan. *British Med. Journal*, Nov. 14, 1903.

especial function or rôle in the maintenance of health, or in combating disease in common with the remaining energy of the spectrum without any danger of untoward skin effects such as would obtain from the same energy when concentrated and condensed.

The indication here is not for a light energy capable of exciting superficial tissue reaction, but for a light energy of great penetrancy capable of the most profound action upon the blood in order that its normal function as the great oxidizer may be accentuated.

To this end the visible frequencies of great chemical energy, the blue, indigo and violet, are needed, but it has always been the author's practice to use the entire energy of the arc. The function of the former is therefore shared by the latter, but the mass of experimental and clinical evidence as well as the absorption spectrum of oxyhæmoglobin point to the former as the fundamentally active frequencies upon the blood.

The action of light in tuberculosis is so evident that it does not even admit of discussion. A glance at its clinical history, at the factors that favor its development and the climatical conditions favorable to either recovery or improvement, bears out the imperative necessity for light energy in this disease—not alone, but in conjunction with the best hygiene and sanitation, good feeding and exercise according to the individual's ability. Fresh air, sunshine, altitude according to the individual patient, but preferably high, conjoined with the above are universally recognized as of more value in combating tuberculosis than all the drugs of the *materia medica*.

De Renzi<sup>1</sup> who was one of the earliest to study the effect of sunshine on disease, undertook to answer the inquiry as regards tuberculosis by inoculating guinea pigs with tuberculous material. It is very evident from these experiments that sunshine assisted these animals materially in combat-

---

<sup>1</sup>De Renzi: *Nature*, 1894.

ing the infection, as the individuals cut off from the sun's rays succumbed much more quickly than those exposed to them. Some of the animals were kept in glass boxes exposed to the direct action of the sun's rays for from 5 to 6 hours daily; while others were placed in the sunshine also, but instead of glass, opaque wooden boxes were used. De Renzi found that the inoculated pigs in the glass boxes, receiving the maximum amount of sunshine, died after 24, 39, 52 and 89 days respectively, while those in the opaque wooden boxes died after 20, 25, 26 and 41 days respectively.

The action of light on tubercle bacilli without the living organism has been the subject of numerous experiments and it is well known that they die rapidly in a sunny atmosphere. Koch showed that tubercle bacilli were killed by exposure to sunlight. Later the electric arc was used for the same purpose, because of its richness in the chemical frequencies, especially the ultra-violet and was found to act even more energetically.

Drs. W. C. Mitchell and H. C. Crouch<sup>1</sup> of Denver, Colorado, made some experiments on tuberculosis sputum in reference to the great degree of immunity against tuberculosis enjoyed by those living at high altitudes. They deposited sputum from tuberculosis patients, as free as possible from mixed infection, on sterilized soil and exposed it to sunlight from one to 55 hours, 6 hours daily. Guinea pigs were then inoculated at varying periods. Control-pigs injected at once died in 20 days. Of those animals inoculated with sputum exposed more than 35 hours none died. Pigs inoculated with sputum exposed only for 35 hours died of tuberculosis, but from the lesions, the infection in those animals was thought to have been due to inhalation. After exposure of from one to 25 hours, the sputum killed the pigs in all but one case, by tuberculosis, that one alone dying of sepsis. None of the animals infected with sputum which had been exposed 35 hours died of tuberculosis. Opportunity

---

<sup>1</sup>Philadelphia Medical Journal, June 11, 1898.

is offered, however, in that period of time for desiccation of the sputum and infection of others. They reasoned from these experiments that the dryness of the atmosphere preventing the growth of the bacilli, as well as the sunshine, was therefore a factor in determining the good effects of the Colorado climate especially in tuberculosis; and that this was added to by the high altitude, increasing as it did the blood supply to the lungs and improving the nutrition of the patient.

Baradat<sup>1</sup> likewise finds that light enriches and nourishes the blood, produces a great reserve of energy, stimulates the nerve ends and vivifies the nerves; it acts upon the skin, accelerates its action and is able to renew the same. In his opinion, light attacks the bacilli directly and by its action, the condition of the tuberculosis soil is ameliorated and renewed. In the article quoted, he reports two cases that had been treated for 6 weeks; after 6 days' treatment the night sweats ceased, the cough diminished despite unfavorable weather and defective care, and the number of bacilli decreased.

Dr. Albert E. Sterne,<sup>2</sup> of Indianapolis, Indiana, also finds the electric arc valuable in tuberculosis. He finds its use as rational as sunlight itself and that the chemical frequencies from it possess a decomposing, but at the same time, reconstructive molecular action upon the body tissues mainly upon the blood elements. He used in addition to the great quantity of light from powerful voltaic arcs, free ozone developed from an especial ozonating apparatus, as described under alternating-current light mechanisms.

Freudenthal<sup>3</sup> has used electric light in tuberculosis for a number of years, having used it since 1889 in tuberculous laryngitis. In that year he first exposed the larynx to the light from an incandescent lamp of very low candle-power

---

<sup>1</sup>Zeitschr. für Tuberculose, und Heilstaettenwesen, 1903, Bd. V., Heft I.

<sup>2</sup>Paper read before the Mississippi Valley Med. Ass., Kansas City, Mo., 1902.

<sup>3</sup>Freudenthal: N. Y. Med. Journal, July 12, 1902.

but for the purpose of transilluminating the laryngeal region as an aid to diagnosis. He was led to investigate the matter and also to continue its use by the statement of a patient for whom at first light was used as a diagnostic aid. It was then discontinued and the treatment carried on, along the usual lines. One day the patient asked why he did not use that light treatment any more, saying that she always felt better from its use. From that time he has used it uninterruptedly in this condition. In the more recent years he has used an electric arc in preference as it is the better source of light energy for tuberculosis pulmonalis and even for laryngeal troubles.

He has found that the marine searchlight mechanism (see Fig. 21) stands him in good stead. In the beginning of the treatment for some of his cases he uses the blue glass screen, shown in the same figure, to eliminate the frequencies below the blue on account of the heat. As a rule he prefers the use of all the frequencies of the arc, as pointed out by the author. He attributes some bactericidal power to the red frequencies even. That they are chemical to a degree is true, according to the nature of the body or substance upon which they fall, and it is possible that they may have some bactericidal power, although more recent work places the bactericidal rays in the middle third of the ultra-violet region. In utilizing the marine searchlight as a source of light energy, Freudenthal uses the parallel rays, and directs the patient to turn the body around in order to prevent any undue heat effect. He also keeps on hand pieces of linen on ice, with which the exposed parts are quickly washed as soon as they become hot. The distressing symptom of dysphagia from which patients with tuberculosis of the larynx suffer, has yielded to a greater or less extent from the use of light in his hands. In a case in which laryngeal stenosis had occurred, tracheotomy had been performed. Afterward upon examination it was found that the epiglottis covered almost the entire entrance of the larynx. He had also tuberculosis of both apices, though not far advanced and suffered from



excruciating pains in the larynx, which no drug could relieve. As a dernier resort Freudenthal tried the electric light for him, which was the only thing that afforded him some relief. At least he was able to take some food.

In the light treatment of tuberculosis, it is not that in the intense chemical frequencies of light there is an energy capable of bactericidal effect primarily, but that there is an energy which judiciously expended tends to the active oxygenation of the blood, improved metabolism and consequent nutrition. In other words, every application within the recognized limits of the best therapeutic management of a given case increases physiologic resistance which results in the fortification of the individual for the conflict. The destruction of the enemy within the organism follows in the natural order of things in 2 ways, (1) by the improved nutrition and vital energy, and (2) by the ability of the rhythmic vibrational activity of the higher chemical frequencies to unduly agitate, shake up or worry the micro-organism until it delivers up its energy or oxygen. But it cannot be too strongly stated that the fortification of the individual is by far the most important consideration, and to that end every effort should be bent, not alone in the exhibition of light energy, but in attention to every detail of hygiene and sanitation, fresh air, suitable exercise, good nutritious food, and sunny and well ventilated rooms. No matter what the special means used to establish a cure in tuberculosis, or for that matter in any disease, no known physical law should be disregarded, nor the use of any accredited measure. But there is no class of cases where the skilful use of light energy is so imperative or of such great avail as in tuberculosis. The hygiene, sanitation, climatology, prophylaxis also of tuberculosis have come in the last years to be above criticism, but the therapeutic management, despite the use of all the accredited physical agents, will fall short of what it should be until light energy is skilfully used in its treatment, not only in institutions but private practice as well. It does not matter, from the author's point of view, that the most in-

tense chemical energy does not penetrate into the deeper structures. The very fact that they are absorbed by the first thick layers of blood vessels of the thoracic walls, for example, does not militate against their usefulness. The tiniest mountain rivulet, the merest thread of a stream in its steady onward flow toward the valley is a source of energy which helps eventually to swell the tremendous flow of water through the mountain cañon. Equally true is it that the absorption of these very refractive frequencies by the oxygen-carrying corpuscle of the superficial blood vessel imparts a stimulus, the influence of which must be felt to the uttermost extent of the circulation of the blood. In tuberculosis there is no greater necessity than for perfectly oxygenated blood. The increase of red blood corpuscles is associated with an increase of white blood corpuscles, bacilli are deprived of their energy, normal tissues are properly fed, and degenerated masses are removed through the increased leucocytosis.

The statistics of those experienced in the treatment of tuberculosis have shown that in order to obtain favorable results the patient must be secured when the disease is in the first stage or stage of infiltration. Not only the physician, but the general public as well, should recognize the necessity of the most earnest efforts when the disease is in its incipiency, and in addition to the hygiene, sanitation and climatic conditions, there should be added in every case the systematic use of the energies of (1) solar light where available, and (2) of the electric arc when the former cannot be commanded. Reliance upon the results of the sputum examination to establish the diagnosis cannot be too strongly condemned. It is unquestionably one of the potent factors leading to a paucity of favorable results. The fact of the presence of bacilli in the sputum, while technically the conclusive proof of the disease, should not be waited for before placing the patient under the best conditions from every point of view. Both the microscope and the Roentgen ray are valuable aids to the diagnosis of tuberculosis, but neither

the one nor the other can take the place of a careful and intelligent physical examination. One, two, or three negative sputum examinations are not sufficient evidence in view of physical signs, to withhold a diagnosis, and no physician should wait until the lungs break down sufficiently for the throwing off the tubercle bacilli, to establish the very best therapeutics. Were this always done, then an expenditure of light energy would hasten the recovery of every such patient. This is well illustrated in Case IV. of the 6 cases of tuberculosis reported from the author's cases.

Treatment was first instituted by the author in cases of tuberculosis in the spring of 1895 by means of the electric arc.<sup>1</sup>

The patient was placed in the arc cabinet previously described, exposing at first the anterior surface of the body.

By changing the position and lying with the posterior part of the body uppermost every square inch of skin surface was exposed to all the radiant energies of the arc, and at the same time to the gases given off by it, which exert a favorable influence. A part of these cases were treated at the author's clinic (The New York Electro-Therapeutic Clinic and Dispensary), and a part in the private office. At the former alternating-current arcs were used, at the latter direct-current arcs. The results obtained indicated that the one was as good as the other. Under the physics of the electric arc it has been stated that theoretically alternating-current arcs should give off more ozone, as it is supposed that such ozone as is given off by an electric arc is due to the breaking of the arc, and by reason of the alternating E. M. F. there is a constant make and break of the arc, i. e., at every change of sign.

These exposures were made to the entire nude body for from 25 to 45 minutes daily in private practice, and later

---

<sup>1</sup>Transactions of the American Electro-Therapeutic Association, 1898, New York Med. Journal, Jan. 28 and Feb. 4, 1899: "The Electric Arc Bath," by Margaret A. Cleaves, M.D.

on, as the case progressed, less frequently. In clinical practice 3 treatments per week were given on the regular clinic days. There was invariably secured by this light bath, diminution of cough and expectoration, freer respiration with increased respiratory capacity and quickened circulation. Its use was always followed by a sense of well being and a general appearance of refreshment. Improvement was the rule in every case, lasting in the incurable cases for varying periods of time. A laryngeal ulcer in an advanced case of phthisis, which had defied every effort of skilled specialists, promptly healed in 2 weeks' time without any local application whatever, even of the light energy, while all the symptoms were ameliorated, and marked nutritional gain established. See Case II.

Acute Phthisis.—E. M., a man aged 28 years; married; carpenter. January 23, 1897.

Patient presented himself because of cough, with pain in chest, following a malarial attack last summer. Now has constant cough, muco-purulent expectoration, night sweats, cachexia.

Inspection: Skin pale and white; emaciated; clavicle and ribs conspicuous; retraction of chest walls, with impairment of motion in infraclavicular spaces; heart beat in normal position accelerated.

Palpation: Vocal fremitus increased at right apex.

Percussion: Marked dulness over right apex, extending to fifth interspace.

Auscultation: Broncho-vesicular breathing, sibilant and subcrepitant râles over right apex. Increase of vocal sounds. On left side very harsh inspiration and broncho-vesicular expiration. Pulse, 100; temperature, 100.2°; weight, 121 $\frac{3}{4}$ .

Treatment: Electric-arc bath; exposure from 20 to 30 minutes; temperature of bath, 90°F. Five treatments given, extending over a period of 2 weeks. At second visit "more life and energy and felt like getting around," before "felt like sitting about"; appetite better; cough diminished. At time of the third visit, further diminution in cough; sputum

less purulent. At the fourth visit cough was much diminished, strength increased, a sense of well-being present.

Improvement maintained; no night sweats while under care, save night following first treatment; improved color; gain in weight,  $2\frac{1}{2}$  pounds. The patient through whom he came to the clinic reported, 2 weeks later, continued improvement, and that he had gone to work again. Subsequent history not known. Two specimens of sputum were secured and examined, but the bacillus tuberculosis was not found. Examination not regarded as conclusive.

Chronic Phthisis.—J. B., a man aged 40 years; married; plate printer. December 28, 1897.

Has worked in a plating factory (bronze) for 8 years. Onset sudden; began to cough and expectorate muco-purulent matter November 1, 1891. Condition has persisted for past 6 years; morning cough and almost daily expectoration. For past 7 months dyspnoea on exertion; evening temperature. Under medical care for 5 years; thinks he is no worse than one year ago, save increased dyspnoea. Has had 3 tubercular ulcers (laryngeal); 2 disappeared under treatment, third remains. No history of consumption in the family.

Physical Examination.—Inspection: Emaciated; waxen skin; marked dyspnoea; incessant cough; impairment of motion in intraclavicular spaces; clavicles conspicuous; heart beat accelerated; respirations more frequent than normal.

Palpation: Skin warm and dry; increased vocal fremitus both upper lobes, especially right.

Percussion: Marked dulness upper lobe, right, less marked on left.

Auscultation: Increased vocal fremitus both upper lobes; cavernous breathing on right; subcrepitant râle right lower lobe posteriorly; friction râle on left, low down.

Examination of Sputum: Bacillus tuberculosis found.

Treatment: Electric arc bath; exposure 35 minutes; temperature,  $90^{\circ}\text{F}$ .

Twenty treatments given, extending over a period of  $7\frac{1}{2}$  weeks. At first visit, incessant cough from time of entering clinic room up to going into bath. Just before conclusion of bath marked moisture of palms, hands and forehead observed.

Sensation of bath pleasant; coughed but once during its continuance, and but once for 25 minutes afterward. Two days later, at second visit, stated that he had coughed less since treatment than during the same time for 2 months previous.

At conclusion of second treatment hands and forehead moist as before; no cough; freer and easier respiration during bath.

At the third visit reported less dyspnoea. At the fourth visit, January 6, 1898, no cough night of previous treatment, January 4; once night of 5th; not at all during day of 6th. Rate of respiration diminished from 40 before first treatment to 30.

At the fifth visit, 11 days after coming under care, dyspnoea diminished; able to walk several blocks without getting out of breath.

Expectoration of a saltish taste instead of sweetish as before, more nearly normal in color, contained less purulent matter.

At the sixth visit, 2 weeks from beginning of treatment, had an irritative cough, with discharge from posterior nares. Walked 10 blocks 2 days previously; dyspnoea slight; expectoration decreased; color of skin improved; sleeping better; no cough while at clinic, an hour and a half; laryngeal ulcer healed; throat much less anæmic. Throat examined January 10 at Throat Clinic, New York Polyclinic, healing of ulcer also noted.

At the first 6 visits the electric arc bath alone was used. Beginning on the seventh, and for the remaining 14 treatments it was followed by the static electricity, positive insulation, convective discharge with crown electrode, 10 minutes, and with brush electrode, to entire general surface

(nutritional) localized to chest walls front and back (lungs), 5 minutes.

During seventh bath no cough. Three and a half weeks after coming under care increased strength; brighter facies; better color; eyes not so preternaturally bright. Improvement continued, characterized by diminished cough, expectoration, improved appetite and sleep. On January 18, nasal and throat examination revealed hypertrophic rhinitis and pharyngitis. For this 2 applications of intranasal cupric electrolysis were made at intervals of 9 days. About the first of February for a day or two appetite not good; cough slightly increased. Sputum examined on admission to clinic 2 weeks later, and again at end of 4 weeks; bacillus tuberculosis found in every instance; fewer in the field at last examination.

At no time while under treatment did patient have special nursing, and exceptionally sufficiently nourishing food. This was especially true during the month of February. February 22 admission was obtained to St. Luke's Hospital in order that he might have care and nutritious food during the trying weather of the spring months. For the first 11 days gained 5 pounds, which he lost in the next 10 days. Three weeks after entering hospital complained of sore throat. Examination revealed 2 tubercular ulcers on laryngeal cartilages. In the hospital until April 1; unable to swallow food; discharged April 1, 1898. Returned to clinic April 7, 1898. Emaciated; extreme pallor; dyspnoea, and exhaustion. No physical examination made because of the patient's great exhaustion, but the following treatment was given: Static electricity, positive insulation, convective discharge, chain in hands, with crown electrode 15 minutes, and with brush electrode to the entire general surface (nutritional), localized to the chest walls, front and back (lungs), and over laryngeal region (ulcers), 10 minutes.

Patient felt brighter and stronger after treatment, dyspnoea lessened, improved circulation, return of color to face, able to get downstairs more comfortably. The query

naturally rises, might not the improvement established have maintained itself if the patient could have had continued treatment while in the hospital, where food and care were provided? It is impossible to answer the question now, but it seems reasonable to believe that under proper conditions the continuance of the treatment would have led to better and more permanent results. This patient was living a month since (about August 7) and up and about. Owing to change of residence cannot ascertain his condition at this writing. For several years he had been given creosote, nor was it discontinued when he came under care, on account of his desperate condition. The relief obtained, however, was coincident with the establishment of his treatment by means of the electric bath, and progressive under its use.

Acute Phthisis.—B. B., a woman aged 35 years, single; seamstress. January 4, 1898.

Patient had la grippe 5 or 6 years ago; pleurisy 4 years ago, and since then when she takes cold suffers pain in breathing, left side. In May, 1897, contracted a severe cold; tired; pains all over body; knees, ankles, and hands stiff; in hospital 8 days; improved. Has not been fully well since; now pain and stiffness in shoulders, arms, fingers, and feet; badly nourished; constipated. For malnutrition and rheumatism the following treatment was given: Static electricity, negative insulation, disruptive discharge, sparks long, clean and percussive to entire general surface (nutritional), localized to affected joints (pain and disability), and to lumbar and sacral plexuses, hepatic area and abdominal walls (constipation). Eighteen treatments were given, extending over a period of 4 months, establishing marked nutritional gain, with great relief from pain and stiffness and constipation.

Patient discontinued regular attendance April 2, 1898.

On April 16, 1898, returned, complaining of sore feeling through chest, with muco-purulent expectoration. Usual treatment given, but could not remain for physical examination.



May 3, 1898.—Physical examination: Congestion of right lower lobe, difficult breathing; hard, dry cough, scant expectoration.

Treatment: Electric arc bath; exposure 30 minutes; temperature of bath, 90°F. Nine treatments given, covering a period of 5 weeks. Following first treatment respiration freer and easier; appearance brighter. May 5, sputum examined, bacillus tuberculosis found. At the second visit looked much brighter, less worn, no sense of oppression in breathing since last treatment, cough looser. Physical examination made at time of fourth treatment showed sibilant and sonorous râles, and elicited the fact of moderate expectoration. After fifth treatment patient felt stronger; coughed less. Continued improvement characterized by increased strength; more energy; diminished cough and expectoration, freer respiration. Clinic closed June 11 for summer holidays, therefore further treatment could not be given. Arrangements were made to send patient to the country under the auspices of an association for the relief of working girls, the subjects of tubercular troubles. Over-fatigue and exposure to night air incident upon her going for the necessary physical examination by the physician of the association brought on an exacerbation of her trouble, and she did not leave the city until July 30. On August 16 reported by letter from Franklin County, New York, that she had gained 3 pounds, and was much better.

Acute Phthisis.—M. E. L., married. Came for consultation March 31, 1898. Family history good; no consumption; patient had systematically overworked in the active care of a large business concern; general health poor for several years; worse for a year past.

In the spring of 1897 began to cough, lost strength and flesh. In the same summer took a sea voyage and was absent from his business several weeks. Nutrition improved and cough diminished during this time, but soon after his return took cold, cough returned with loss of flesh and strength and increasing nerve irritability. In September he

was seen by his physician and examined also by Dr. Delafield. Trouble was found at the apex of the right lung, and bacilli in the sputum. Dr. Delafield told him he must give up his business and go elsewhere in order that he might be under suitable climatic conditions. The patient was very much averse to this, and decided that rather than give up his business interests and go away he would work as long as he could in order that he might provide in the best possible manner for his family and accept the inevitable when it came.

He did nothing during the winter and early spring, save to take cod-liver oil and hypophosphites. At the time he came under care, March 31, 1898, he was a good deal worn; nervously irritable; had lost and was still losing flesh; coughed a good deal, especially in the morning and at night; wakened by cough between 4 and 5 in the morning; expectoration muco-purulent; appetite poor and sleep broken.

Physical Examination.—Inspection: Patient fairly well nourished. Clavicles and ribs somewhat conspicuous.

Palpation: No change in tactile fremitus.

Percussion: Slight dulness over upper lobe on right, front, and back. Note normal on left, front and back.

Auscultation: Subcrepitant râles above and below clavicle on right over area of upper lobe. Voice and breathing slightly bronchial; increased vocal fremitus.

Examination of Sputum: Bacillus tuberculosis found.

In answer to his question as to whether anything could be done for him, the remedial value of sunshine, whether natural or artificial, and the function of electricity to improve and to restore nutrition were briefly outlined, and the improvement of several cases of phthisis under the influence of the electric arc bath detailed.

He decided to place himself under care, and treatment was instituted on the same day. For the first 14 days treatments were given daily, with the exception of the intervening Sundays.

Treatment consisted of the electric arc bath; temperature of bath, 90°F., exposure varying from 30 minutes to an hour. There was an immediate diminution of the cough, with gradually diminishing expectoration. Improved appetite and sleep, and marked lessening of nerve irritability. At the end of the first week of treatment the patient had gained 3 pounds; cough was markedly diminished; sleep and appetite improved. Improvement continued, and 2 weeks from the day he came under care physical examination was negative, save for a slight increase of vocal resonance at the apex of the right lung. In an examination of the sputum 2 weeks and 3 days from the time of instituting treatment no bacilli were found. The gain at that time in weight was 5 pounds. Throughout the rest of April and during May almost daily treatments were given, Sundays excepted, and an occasional week day. In one instance only was there an exposure of an hour, and that at the request of the patient, to whom the bath was most grateful, but it was followed by unusually profuse perspiration with slight exhaustion. After that time 50 minutes was not exceeded, while the average time was 45 minutes. During the month of June and the first week of July an average of from 3 to 4 treatments a week were given. At the beginning of the fourth week he was directed to secure a third specimen of sputum for examination, but at no time, either in the night or morning, was he able to secure anything, though he carried a bottle in his pocket for this purpose for the following 2 weeks. There was absolutely no cough or expectoration. Improvement in appetite and sleep continued, with a further increase in weight, entire disappearance of nerve irritability, and withal a general sense of well-being. During the month of June his business necessitated his going into a new building, which had not fully dried out, and as a result he developed malarial symptoms. He had at different times in his life suffered from chronic malaria. At that time he was given an anti-periodic, which was the first and only medicine given him while under treatment. Cod-liver oil

was not used, but as much cream was taken as he could digest.

In all 66 treatments were given, extending over a period of 3 months and 10 days. In the second week of his treatment the electric arc bath was omitted for 3 or 4 days, owing to an accident to one of the lamps which was not promptly repaired.

Following the arc-light bath the following treatment was administered: Static electricity, positive insulation, convective discharge with the crown electrode, 15 minutes, and with brush electrode to the entire general surface. At the same time a hypertrophic rhinitis with hypertrophy of the posterior turbinated bodies was treated with cupric electrolysis.

The applications were made with a thin copper electrode having concavo-convex surfaces, by means of which an accurate localization of the oxychloride of copper was made directly over the turbinated bodies. Before instituting nasal treatment there was difficulty in breathing, with profuse post-nasal dropping and constant hoarseness. These symptoms were of several years' standing. In addition to the nasal treatment a slow interruption of the induced current regulated to the patient's toleration was used by percutaneous applications to the throat, i.e., from side to side for 5 minutes, and from nape to larynx for 5 minutes, daily. As a result of nasal treatment nasal respiration became absolutely free, and post-nasal dropping stopped entirely.

The throat became very much stronger under the use of the induced current, with gradual disappearance of the hoarseness, which returned but once while under care, when, owing to a sudden change one late afternoon from the extreme heat prevailing, he took cold. He came to the office the following morning with an acute laryngitis, exceedingly hoarse, with almost a whispering voice. The usual treatment was given: Electric arc bath, followed by convective discharge, and the application of the induced current to the throat.

He left the office at conclusion of treatment with practically a normal voice, and maintained his improvement.

His total gain in weight up to the end of the first week in July was 8 pounds. He is a man of very slight build. He attended his business every day, not losing an hour, save the hour spent in the office for the purpose of treatment. A note on the 6th of July, stating his inability to keep an appointment, ends with the remark, "Feeling fine." On the 9th of July, writing in reference to being away for his vacation, he stated that he was very well.

This patient has been given to understand that the maintenance of his improvement depends very largely upon himself, that every attention must be paid to all matters of hygiene, and that he must have outdoor exercise and sunshine. Realizing fully the nature of tuberculosis, it follows that if at any time his nutrition falls below par the bacilli are apt to become active and the trouble develop anew.

The positive results obtained in this case as well as the improvement obtained in cases of much longer standing are, to say the least, suggestive. Five years later patient remained well and continued in charge of his business.

Acute Phthisis.—M. T., a woman, aged 28 years, single; importer. July 9, 1898.

Father died of pneumonia; mother has chronic malaria; one brother died at age of 6 with "brain trouble." Patient not strong and always nervous as a child. Menstruated at age of 12, usually pain for 24 hours before flow, duration 4 days, amount normal. Has occupied her present position for 8 or 9 years, and has overworked; meals irregular; for past 4 years much mental worry. Life indoors most of the time. Four years ago last February began to go to Paris twice a year to buy goods, since that time less strong; for 3 years tired all the time; unable to get rested; very nervous and has lost flesh during last 2 years. Last February took cold, nose and throat first, finally lungs.

Since then has had a cough, especially on retiring and rising; at intervals muco-purulent expectoration. Every 2

weeks since has had an attack of coryza with incessant sneezing and nasal discharge; malaise and great fatigue. At time of coming under care, morning and evening cough, worse in morning, wakens her, mucous expectoration, at times muco-purulent. Bowels constipated, micturition frequent. July 13, 1898, examination of sputum and *Bacillus tuberculosis* found.

Physical Examination.—Inspection: Patient poorly nourished; retraction of chest walls above and below clavicles, especially on right; skin inactive, pigmented in defined areas over sternum.

Palpation: Vocal tactile fremitus normal.

Percussion: Percussion note, anteriorly and posteriorly over upper lobe of right lung is of higher pitch and of shorter duration than normal. Note over left chest normal.

Auscultation: Vocal resonance increased over upper lobe on right; subcrepitant râles below right clavicle; diminished breathing. Left side anteriorly sounds normal: posteriorly infrascapular region loud sonorous râles.

July 25, 1898.—Sputum examined and *Bacillus tuberculosis* found.

Treatment: Electric arc bath; exposure 20 minutes to an hour. The shorter exposure was given on the hottest days. Free perspiration always established with improved color and rested appearance. At the end of the first 5 days cough markedly diminished both night and morning, expectoration decreased. For the first 8 days treatment given daily except on Sunday; during the 2 weeks following treatment was administered daily with one exception, while the last week but 3 treatments were given.

August 5, 1898. Physical examination: Skin of better color, less dry and harsh; respiration freer; volume increased.

Subcrepitant râles; no sibilant or sonorous râles. Percussion note improved. Sputum examined and *Bacillus tuberculosis* found.

At intervals of 5 days 3 applications of cupric electrolysis

made to hypertrophied turbinated body, inferior left, 5 milliampères, 3 minutes each. At the end of 2 weeks, in spite of the heat of the summer weather and continued application to business, there was a gain of one pound: improved appetite and sleep; general sense of well-being; no cough at night, rarely in the morning; scarcely any expectoration, save from the throat. Menstruation established August 1, free from pain, very comfortable. Is to sail for Europe tomorrow, August 6, to be gone 5 weeks. This patient remained well when last heard of some 5 years after coming under care and able to attend to her business.

Case VI.—J. G., male, aged 20 years; shipping clerk. August 19, 1898. Father dead; mother living and well; one sister, one brother, both well. For the last 2 or 3 years not well, chronic malaria. Began to run down in April last, and had a severe hæmorrhage, pulmonary, at that time. Went to the country, absent until July 4. No hæmorrhage during absence. Made some gain. Since return has steadily lost flesh, troublesome cough, with expectoration; sense of malaise; poor appetite. In July had a very severe hæmorrhage, lost a good deal of blood from which he has not recovered. On July 31 consulted Dr. C. O. Maisch, instructor in diseases of children, New York Post-graduate Medical School and Hospital, who reports the following:

“Slight dulness over left apex, anterior more marked; accentuated breathing. Vocal fremitus slightly increased, no râles. Right lung over apex a few sibilant râles, respiration over both lungs very much restricted. Retraction of intercostales and some dyspnœa always present. Expectoration moderate, cough not very troublesome. Hæmoptysis; anorexia; malaise weakness; emaciation progressive. Sputum contains a very few tubercle bacilli. Temperature, 100.2°; pulse, 110.

“August 12.—Physical examination: Over left apex dulness to within an inch of inferior angle of scapula, and over this area there is marked increase of vocal fremitus; bronchial and tubercular breathing; crepitant and subscrepi-

tant râles; moist mucous râles over the entire surface indicated. Right lung unaffected. General condition much worse. Temperature,  $101.5^{\circ}$ ; pulse, 120; cough troublesome and expectoration considerable.

"August 20.—Patient in same condition; complains a great deal of weakness."

This patient was referred to the writer for treatment August 19, 1898. Physical examination was not made nor treatment instituted until August 20. At that time patient presented appearance of a very ill person, loss of flesh, great difficulty in breathing, rise of temperature, evening and morning cough most marked, occasionally during day, moderate expectoration, poor appetite, regular bowels, malaise, great weakness, and walked with difficulty, even a few steps.

Physical Examination.—Inspection: Patient much emaciated, anæmic; chest walls retracted; left chest flattened, with impaired motion.

Palpation: Marked increase of vocal tactile fremitus over left chest anteriorly.

Percussion: Marked dulness over upper half left lung anteriorly and posteriorly.

Auscultation: Crepitant and subcrepitant râles over area of dulness on left; vocal fremitus markedly increased; harsh breathing. Right side normal.

Patient very weak and obliged to sit several times during the examination.

Treatment: Electric arc bath; exposure 20 to 30 minutes; temperature,  $90^{\circ}\text{F.}$ ; followed by static electricity, positive insulation, convective discharge with the crown electrode for 15 minutes, and with brush electrode to entire general surface (nutritional) localized to chest walls front and back (lungs) for 5 minutes. Afterward sat upon the platform for 5 to 10 minutes daily with ground connection removed and discharging rods within sparking distance of one another. During this time directed to breathe deeply and steadily of the ozonized atmosphere.



Daily treatments given up to August 27, excepting the intervening Sunday, and save in two instances the exposure lasted for half an hour. From the beginning of treatment there was a marked lessening of dyspnœa, increasing respiratory capacity, slight diminution in cough, with, as a rule, less expectoration.

On August 25 appeared very much better; facies brighter; respiration freer; coughing only in the morning, and less than before; taking sufficient food, but without special appetite; lowered temperature and diminished pulse rate; able to walk 5 or 6 blocks without much effort. On the 26th and 27th had rather a sharp attack of diarrhœa, which caused considerable weakness. From August 19 the weather was excessively hot, with great humidity, and as patient's home was a single room in a tenement house in the most crowded portion of the city, he was unable to get much rest at night.

On August 27 referred back to Dr. Maisch for examination with the following result: Temperature, 99°F.; pulse, 115; general condition of patient improved; dyspnœa less troublesome (very much); cough less. Lungs: Left apex, dulness as before, has not extended. Rhonchi seemed fewer in number, and would indicate that liquefaction was not so great as at last examination. Right lung not affected. Moderate diarrhœa. To patient, physician stated, "You are very much better." Treatment: August 29 as before. Slight diarrhœa; coughing but little, and in morning only; raising less than before. In answer to an inquiry as to why the patient did not return for treatment, the following letter is quoted:

"223-225 E. One Hundred and Seventy-sixth St.,  
New York City, September 7, 1893.

"DEAR DR. CLEAVES: Yours of the 2d inst. in reference to J. G. received. I had heard nothing of him, and so looked him up yesterday at his home in Baxter Street. He has been in bed some days. I found him with temperature

104°F., pulse 120, and in pretty bad condition. He has an acute pleurisy on the left side anteriorly. The physical signs in the chest have not changed since I saw him, except that he has developed a diffuse bronchitis, involving both sides. His general condition is worse; his surroundings are bad, and the hygienic conditions hopeless. He has had no hæmorrhage. Should he get up again he will come to you.

Yours,

“C. O. M.”

Summary: Of the cases reported, all save 2 were dispensary patients, for whom there could be neither change of environment nor dietary; 2 were incurable, and yet there was a modification of all the symptoms, with, in one case, healing of a chronic tubercular ulcer of the larynx in 2 weeks' time and with but 5 exposures. The author has no thought that in light energy, whether solar or the electric arc, a panacea for tuberculosis is to be found—far from it; but the uniform results obtained in the preceding series of cases, which were very carefully studied, as well as in the practice of others.

In a case of pulmonary tuberculosis reported by Sciascia, the duration was only 2 months, and while the physical signs were not positive, the tuberculin test evoked a decided reaction. The symptoms of the disease began to subside in 40 days, and 20 more applications resulted in recovery. Seven years later the patient remained well. Sciascia is of the opinion that the treatment would be of value in the pre-tuberculous stage, but that later it can only strengthen the natural forces, and diminish the tendency for the disease to spread. In this the author concurs.

Freudenthal, Kime, Foveau de Courmelles, and others regard light energy as of very great value in curative cases of tuberculosis.

The results of Kime with concentrated solar energy (see Chapter XI.) are corroborative of the author's experience with electric arc light energy. Similar results have since been

obtained by Doumer and Finsen, and in this country 1901-1902, by Hopkins. More recently M. Foveau de Courmelles has had the same clinical experience with pulmonary tuberculosis and has also treated tubercular glands, fistula, and joints with good results. It is well established that short and high frequencies or chemically active energy are the curative frequencies. In most pathologies other than those of the skin, all the radiant energy of the arc is of value.

Tuberculosis of the Bowels.—In a case referred to the author with a diagnosis of tuberculosis of the bowels, woman aged 32, presenting the classic clinical picture, impaired appetite and digestion, especially intestinal, attacks of diarrhœa, emaciation, hard rigid abdomen; there was obtained from the first exposures in the electric arc bath a softening of the abdominal walls, with disappearance of rigidity. This was followed, as the treatment progressed, by improved appetite, increased digestive power, cessation of the diarrhœal attacks, lessened anæmia, increased weight, all pointing to the general nutritional gain. The patient had had pulmonary complications, and at one time bacilli in the sputum. The cough, expectoration and bacilli had disappeared from a long residence in Colorado, but the intestinal complication had not yielded to any form of medication, diet or to the climatic change. This patient made a good recovery, although never strong nor robust, and when last heard from 2 years after treatment remained well. The entire nude body was exposed to the action of the light in the electric arc cabinet described, for from 25 to 45 minutes at first daily, and then every other day. It was followed by the use of the convective discharge of static electricity with crown, and to the entire general surface. The patient was under care 2 months.

In a historic sketch of some of the so-called cures for pulmonary tuberculosis, J. E. Stubbert<sup>1</sup> presents a few notes on latter-day treatment. The various therapeutic methods

---

<sup>1</sup>Medical News, April 9, 1904.

in vogue to-day, including drugs, light, electricity, water, serum, intravenous and subcutaneous injections, etc., are all considered. In the light of present knowledge, diet, hygiene and fresh air are universally accepted as the foundation of all scientific treatment. Upon indication they must be supplemented by symptomatic treatment in the way of antiseptics, tonics and surgical interference. The probability Stubbert believes is that within 3 years notable advances in immunization, and the stimulating effect of light will be seen. Strebel states that the good influence of electric light on the strength and nutrition of the tuberculous, if not too much reduced and debilitated, seems, according to his experience, incontestable. It is well in this connection to recall the experiments of Bergel upon ciliated corpuscles. Upon exposure of a ciliated corpuscle that had been in the dark and was inactive, to the action of light it commenced to oscillate again. In tubercular cases the ciliated corpuscles are inactive because the bronchi are filled with a quantity of secretion. These corpuscles require an extraordinary stimulus in order to take on their movement again. This stimulus is imparted by the light energy of the arc, also by that of sunlight. In both instances the chemically active blue, indigo and violet frequencies, which are very penetrant, *penetrate the deepest* bronchioli, and exercise a direct influence upon the ciliated epithelia. From the stimulus of light energy they resume their oscillatory movement, in other words, they take on their function and the secretions are carried to the upper parts of the bronchial tract, from which they can be removed by expectoration. This physical explanation of the action of light energy in rendering expectoration less difficult is the one made by Freudenthal. In this connection he states, "I remember one patient who was driven to my office daily up to 2 days before her death in spite of high fever and other distressing symptoms. as she always felt so much easier after exposure to the electric light. She could expectorate better and had less pain and less fever. In incipient cases you may bring about a cure

by these means. I believe that some of my cases have been cured in that way, but in advanced tuberculosis electric light is only a palliative measure of occasionally great value."

Freudenthal<sup>1</sup> reports the following cases:

Case I.—A. R., 24 years of age, a drummer, came to me September 6, 1900. He had been well up to a week before, when he caught a severe cold. Since that time he had had intense pain in the throat, more so at night; could not swallow food, although he was hungry. He admitted he might have had a slight rheumatic attack before. The examination showed an acute left tonsilitis and ulceration in the left pharyngeal fossa, both of which were attributed to rheumatism. In a few days the ulcer disappeared under salicylate of sodium and local astringents, and so did to some degree the pain. But very soon he felt it again, "farther up." The left tonsil was more swollen and sensitive to the touch.

Sept. 10.—Tonsil more swollen, no abscess; œdema of the uvula and neighboring parts on the left side. Severe pain. Electric light was applied for 45 minutes to the left side of the throat, with the result that for the first time in 2 weeks the patient slept well.

Sept. 11.—Oedema has disappeared, the tonsil is much less swollen and much less sensitive, and he feels comfortable.

Sept. 20.—Says he does not regain his strength. Has some pain over the chest. On examination, some râles were found over the left clavicle anteriorly, bronchial expiration and tubercle bacilli in the sputum. He was treated daily with electric light for about 5 weeks, when all the symptoms had disappeared. He went back to business, and has been in good health since.

In this case the effect of the electric light application to the tonsil and uvula was simply remarkable, and the patient was most grateful. The primary conditions, however, were

---

<sup>1</sup>N. Y. Med. Journal, July 12, 1902.

believed to be of a rheumatic nature, although the pain was very great. When, later on, tuberculosis developed the result was not so quickly obtained as in the beginning, but when obtained was extremely gratifying.

Case II.—Miss M., aged 17, hoarse for a year, coughed occasionally, had night sweats, no appetite, and often felt dizzy. She was very anæmic, which showed itself especially in the pharynx and epiglottis, while the other parts of the larynx were rather congested and partly thickened (infiltrations?). The lungs showed dulness over both clavicles, more marked on the left side, slight râles anteriorly and posteriorly, and bronchial breathing over the left clavicle. Besides, there were hypertrophies in the nose, which were removed. The sputum could not be examined, as she raised none, but there was no doubt but that the condition was that of tuberculosis. She remained in this city from April 25 to July 5, 1900, after which time she went to the mountains. The symptoms gradually disappeared, there were no râles, breathing was vesicular, there was no rise of temperature or night sweats when she was discharged. The larynx was still congested, and her appetite had improved but little. Subsequently she was reported well. In this case of incipient phthisis a "cure" was also effected, so far as a cure in such cases can be obtained, which was largely due to electric light.

Since the author's first experience with light in pulmonary tuberculosis there has been noted in all the literature of the subject, not only the same improvement but the same order of improvement in the experience of different operators which was first noticed and recorded in the writer's cases; an improvement which in curable cases resulted in recovery; in incurable cases, in a relief from distressing symptoms and increased comfort while life lasted, even to the end. Such a uniformity of experience as to the disappearance of symptoms and result would not obtain were the agent used other than potent of good. In the profound action of the chemical frequencies of light upon the blood,

especially upon the red blood corpuscle, thereby increasing its oxygenating power, is to be found sufficient and rational explanation of the action of light in tuberculosis. Especially true is this, where the naked chest walls or the entire nude body is exposed to the action of chemical light from powerful sources of light energy.

The blood which passes and repasses in a long exposure through the illumined area, absorbing the penetrating chemical frequencies, and as absorption of light energy does not take place without work being done, the result is an impartation of a stimulus or energy to the absorbing media. The extinction of energy in space or its absorption and consequent disappearance in matter is a deep-seated fact in nature. If waves of light strike a growing plant they do work; and to this end are absorbed all above the green. The red medium of the blood, with its magnitude of function, upon which life depends, cannot, according to physical laws, be an exception to the law of light absorption; a law which has been abundantly proven by experimental work and clinical observation. The absorption of light energy by the living organism is one of great import, and by it the writer believes is to be found the key to read the letters of life, just as the astro-physicist regards it as "the key to read the letters of the universe."

An exhibition of electric arc light energy has not only yielded good results at the author's hands in tuberculosis of the lungs but in all diseased condition of the respiratory mucous membrane which have offered themselves for treatment.

Among these conditions may be mentioned chronic bronchitis, bronchial asthma, convalescence from la grippe and broncho-pneumonia characterized by constant harassing cough and profound exhaustion, hay asthma and acute catarrhal colds.

In the treatment of all diseases of the respiratory system, as well as in catarrhal conditions of the nasal passages, there have been secured certain definite and invariable results: viz., improved respiration, fuller and slower, with gradually

increasing respiratory capacity ; diminished irritability of the mucous membranes and lessened discharge. Improvement from the harassing cough has invariably been noted from the first exposure. In acute catarrhal colds with sneezing and coryza, exposure to the light energy of the arc uniformly results in complete control at the time of these manifestations. If the condition be taken sufficiently early its further progress is arrested.

In hay asthma a similar result is obtained. From single exposures of a half an hour to an hour, the râles over the chest and the sneezing will disappear.

It may be thought that the element of suggestion enters here. The author thinks not, for similar results though less brilliant have been obtained in cases of hay asthma from an expenditure of electrical energy (1) intra-nasal cathodal electrolysis with mild current, 5 to 10 ma., (2) the action at the anode on oxidizable metals, copper notably, 5 to 10 ma., (3) vacuum tube discharges from a static machine either with or without a transformer.

Freudenthal has also had experience with this same class of cases. He states that during the last 2 years he has treated 24 patients with hay fever. The following statement embodies his results and opinion. "Out of these 14 experienced decided improvement in all respects very soon after the treatment was commenced. In some cases the profuse discharge from the nose, sneezing and asthma were relieved right after the first exposure to light. All these fourteen patients could stay in the city and attend to their business, but of course had to come for treatment regularly. Six of these 14 were treated during 2 seasons and it seemed as if all had much weaker attacks the second time than in the previous year. The rest of the patients, 10, improved but little or left treatment too soon to form an opinion.

"The following will serve as an illustration :

"Mr. C. K., aged 35, manufacturer, came under observation September 9, 1900. A year before he was attacked for the first time by hay fever, and this year it commenced as



early as August 6 at noon (!) He had all the symptoms of this disease in a very aggravated form; sneezing, running of the nose and eyes, asthma, insomnia, loss of appetite, etc. Suprarenal extract was applied to his nose and he was exposed to the light, when he professed to feel like a new man. Besides he was given hydrochloric acid to take internally, and in 2 days he went to business again. He was seen every 2 or 3 days until the beginning of October, when he had no further trouble.

“The good result in this case was so much the more remarkable as this patient had been subjected to all sorts of treatment. He even saw a very prominent consulting internist in this city, who told him nothing could be done for hay fever patients! The following year treatment was instituted on July 16, in order, if possible, to avoid a recurrence. A certain degree of success was obtained, as the symptoms were much less marked. Only from the 4th to the 7th of September he felt quite heavy. At other times he occasionally had slight sneezing and rattling in his chest, which reminded him that he was not as yet out of it entirely.”

This one case may suffice for a series of others which showed similar, although not always such distinct results. Freudenthal considers himself justified in declaring the electric light treatment a very important factor in combating the symptoms of hay fever. Whether this is due merely or mostly to suggestion he does not know, but the symptoms of hay fever are so unpleasant and so annoying that we must try any remedy at our disposal to relieve them.

The Electric Arc in Bronchitis.—In a case of chronic bronchitis in the author's practice, male, age 40, habitual drinker, complicated by Bright's disease, albumen occupying one-third of the tube used for testing the urine, there was constant and harassing cough, with pink-colored sputum. Despite the fact that almost a week was spent in hard drinking during a period of  $2\frac{1}{2}$  weeks there was secured by the action of the light energy complete relief from the harassing cough and expectoration with for a time a

slightly improved renal condition. Some 6 months later he succumbed to the chronic nephritis. Prior to his coming under care he had not only been given the classic remedies, but he had spent some months in Asheville, N. C., and in Southern California without benefit.

The following case given in detail as a clinical guide is illustrative of the course of these cases under treatment.

Subacute Bronchitis.—F. W., a girl aged 3 years. December 3, 1896.

At the age of 16 months patient had pneumonia, at 2 years tonsillitis, and 8 months subsequently malaria, intermittent type. Two weeks prior to admission contracted a severe cold, characterized by febrile disturbance, loud breathing, moaning in sleep, pain through chest and cough at night.

Physical Examination.—Subcrepitant râles over chest anteriorly and posteriorly; crepitant râles in inferior clavicular region left; sibilant râles right.

Treatment: Electric arc bath; exposure 20 minutes; temperature of bath, 90°F.

Eight treatments given, covering a period of 6 weeks and a half. Pulse and temperature records taken before and after treatment showed that the pulse, markedly irregular before treatment, became normal in character after the first 3 treatments. It was uniformly diminished in rate and of better volume. Upon leaving the bath the skin was warm and moist and respiration freer.

At the fourth visit physical examination revealed the presence of large mucous râles, and the mother reported that the cough was looser. After the fourth treatment patient did not cough during the night. The congestion gradually disappeared, appetite and sleep improved, and respiration became normal. Patient always fell asleep in bath. Discharged recovered. No drugs given.

September 1, 1898.—No trouble since.

Nocturnal Enuresis.<sup>1</sup>—J. C., 21 years of age; suffering

---

<sup>1</sup>This case was first reported in 1894.

from anæmia and enuresis. The electric light bath was given for 20 minutes. The patient was placed upon a stool within the cabinet, with the entire body exposed to the rays of light, special attention being paid to localizing it over the lumbar and sacral plexuses. The treatment was entirely experimental, but with the expectation of, at least, improving the nutrition. The patient had suffered from nocturnal enuresis as far back as she could remember. Menstruation was established at 17, and was perfectly regular. All the conditions were normal, save that the patient was decidedly anæmic, and suffered from facial acne; the pupils were always dilated, and there was a tendency to constipation, the bowels often moving but once in 2 days—rarely 2 or 3 days consecutively. The wet nights were slightly variable; she would sometimes go in summer 2 or 3 nights without trouble, but rarely for this time in winter. In all, 16 treatments were given, extending over a period of  $1\frac{1}{2}$  months, 3 times weekly. Careful examinations of the urine were made at first, and the pulse, temperature and skin were carefully watched. Thirteen observations were taken of the temperature and pulse. In 11 instances the pulse dropped, and it was always of better volume after the bath. In 2 instances the pulse remained unchanged but with improved volume; while in every instance (13 times) there was a rise in the temperature of from .1 to .8 degree. The skin always became moist under the application and during the last treatments perspiration was very profuse. There was a general sense of well-being expressed by the patient after each application. Soon after coming under treatment the bowels became regular, and there was no trouble during the time she was under care, not since then, a matter of nearly 6 months, excepting for a few days at one time after discontinuance of treatment, when very much hurried making preparations for leaving the city, she was slightly constipated. The urine was analyzed from time to time, and showed a steady increase in the amount of urea eliminated. The patient gained  $1\frac{1}{2}$  pounds during the first 2 weeks,

and since that time has gained 7 pounds more, and is in better health than for several years. The temperature of the bath varied on different days, being affected by the outside temperature, but ranged from 90° to 100°F. The patient always left the office feeling much better. No drug of any sort was given or allowed the patient during the time she was under observation.

**Eczema.**—In the case of a young girl, aged 13, with chronic eczema, several years' duration, of the fingers and hands, where every finger, thumbs also were cracked and fissured, preventing piano practice or use of embroidery flosses, every crack and fissure save one healed from a single half hour exposure to the energy of the arcs in the cabinet described. So brilliant a result as this does not indicate that a single treatment is sufficient. On the contrary, for in order to secure a complete and lasting cure, it is necessary that the light energy should be expended over a period of time greater or less according to the underlying conditions.

It is only by the establishment of nutritive changes or the alteration of a dyscrasia, through normal oxygenation of the blood and metabolism, that the eczema, the expression of the one or the other, will disappear. The following case illustrates the action of light energy in the same class of cases. There was no accurate concentration of the light in either case as with the mechanisms for skin work. In fact, both cases were treated before Finsen's therapeutic work was done.

**Eczema Cruris.**—A. M., a woman, aged 29 years, single; dressmaker. February 18, 1896.

Presented herself because of spot on anterior surface of right leg. One year since fell and scratched her leg below the knee. Spot became red, infiltrated, itched moderately with tendency to moisture, stocking adherent; later crusts appeared on the surface.

**Physical Examination.**—A patch size of palm of hand below patella, color dull red; covered with crusts and exuding moisture; tissues underneath thickened and swollen.

Treatment: Continuous current, active electrode, 6 square inches in area over eczematous surface negative; indifferent electrode right foot in normal saline solution. Temperature,  $100^{\circ}\text{F}$ ., 5 milliamperes, 10 minutes.

Four applications were made, extending over a period of 10 days. After second treatment marked hyperæmia over upper part of patch; tissues softer, with partial loss of crusts. After third treatment several islets of healthy skin visible, fewer crusts; improved circulation. Because of general malnutrition treatment changed from local application of the continuous current to general nutritional treatment as follows: Electric arc bath; exposure 30 minutes; temperature of bath,  $90^{\circ}\text{F}$ .

Two treatments extending over a period of 16 days. Not able to come for further treatment because of a severe cold contracted from exposure going to and from her work. In May reported through a friend that the patch of eczema had entirely disappeared. No drugs given. From clinical experience with other cases of eczema treated solely by the continuous current the opinion is justified that the prompt and complete disappearance of the eczematous spot was due to the action of the electric arc. The light was focused directly by means of the adjustable reflector or silvered mirror on the spot of eczema.

Psoriasis.—No attempt has been made to treat psoriasis by means of concentrated light, but such cases as have presented themselves have been treated by means of non-concentrated arc light energy, in the author's cabinet.

The cases treated therein made prompt recoveries, and the belief is entertained that a general treatment is much more efficacious in these cases than a local treatment. Here again the psoriasis is but an expression of the systemic condition.

A young woman, aged 18, whose body was not only covered with psoriasis eruption, but who was profoundly anæmic, lost every patch and scale in 3 weeks' time, the anæmia lessened with increased hæmoglobin, and the gen-

eral condition improved from exposures varying from one-half to three-quarters of an hour every other day. This patient after a lapse of 4 years has never had a similar recurrence. When closely confined indoors, and anæmic she has seen now and then a spot or two, but at no time has the body been covered as before. The conditions of her life are not favorable to the best of health, and she has suffered from anæmia from her infancy.

Sterne also mentions having treated in his alternating-current arc both eczema and psoriasis. The following case, also from the author's case book, is equally illustrative.

Psoriasis Universalis.—H. B., a woman, aged 26 years, single; nurse. April 10, 1895.

Referred from the New York Skin and Cancer Hospital.

Physical Examination.—General eruption over body, more marked on extensor surfaces of arms and legs; red papules covered here and there with silvery white scales; no discharge; conjunctiva and gums anæmic; depressed; case has proved an obstinate one, and has not yielded to classical treatment.

Treatment: Electric arc bath; patient nude; exposure 30 minutes; temperature of bath, 90°F. Four treatments given, extending over a period of 9 days. After first bath, circulation improved, skin warm and moist; patient felt warm and comfortable and looked rested.

At second visit improved appetite and sleep with general sense of well-being. After second treatment remarked that she "felt that she had been born again." Improvement continued, characterized by nutritional gain and clearing up of the skin. Treatment suspended at end of 9 days, as patient had to leave the city. Subsequently heard from through an interne of the New York Skin and Cancer Hospital, who reported that she was entirely well. No drugs given. In this case, as well as every other reported, the patient always looked rested and refreshed upon leaving the bath, skin moist and rosy, eyes bright.

Nervous Diseases.—The rôle of light energy in the

treatment of functional nervous disorders especially, is not clearly established. That there is an action other than upon the blood, important and far-reaching as that is, seems evident. Under the biological action of light, this has been considered as fully as present experimental work, superimposed upon physical fact and physiological action justifies. The writer is of the opinion, however, that by far the most important action is upon the blood, and that by the absorption of light energy of definite frequencies, a stimulus is imparted the influence of which extends to every organ and tissue of the organism. There is undoubtedly a field of very great usefulness for the use of light in nervous disorders. In no class of functional nervous disorders is its exhibition of more avail than in neurasthenics.

It is a matter of daily observation in the author's private practice that in neurasthenic patients suffering from intense nerve irritability, exposure of the superficies of the entire nude body to the radiant energy of the arc, without the intervention of screens of colored glass for from 20 minutes to three-quarters of an hour results in lessened nerve irritability, improved circulation, and a sense of well-being formulated by them as a sense of "refreshment and repose," which is strongly at variance with their condition before treatment. In this class of patients, the sense of repose and well-being is much more marked from the effect of the arc light bath than from the usual electrical treatments. It is by reason of its nearness of physical kinship to light that high frequency currents serve to favorably influence the same class of cases. This was markedly the case of a noticeably neurasthenic patient, in whom the nerve irritability had been accentuated by reason of an exhausting menstrual flow associated with over-fatigue and anxiety, and who also suffered from great apprehension and morbid fear evidenced by her voice and mien as well as vouched for by the patient prior to treatment. An exposure of half an hour resulted in a more active circulation as evidenced by pulse and skin coloring, from absolute pallor to one of normal

coloring, in the most marked lessening of nerve irritability, the disappearance of sense of apprehension and a sense of general well-being. The improvement established by the one exposure continued until the next on the following morning. The rationale of the action necessitates, as with the expenditure of any form of physical energy, or for that matter—chemical energy in the form of drugs, repetitions of the treatment over considerable periods of time and at intervals, frequent at first but later less frequently. With the firm establishment of nutritive changes, they should be discontinued, or in some cases, a more energetic or a coarser stimulation, so to speak, may be necessary after the first few weeks, in the form of electrical treatment. The administration of tonics, nerve or circulatory, must be left to the judgment of the individual physician, and should be given if indicated, although many patients will recover without their help. Perhaps no one has given more attention to the use of light in the treatment of neurasthenia by the use of the chemical frequencies of light than Dr. Albert E. Sterne,<sup>1</sup> who presented an interesting paper upon the subject to the section of nervous and mental diseases, at the fifty-fourth annual session of the American Medical Association.

For the past 6 years Sterne has used the chemical frequencies of light in a considerable array of conditions, neurasthenia and debility, pulmonary tuberculosis, diabetes, syphilis, rheumatoid affections, as well as distinct organic nerve conditions, also in the many localized conditions so often encountered in neurotic subjects, notably acute and sub-acute pelvic inflammations and exudates. In the 6 years in which he has employed light therapeutically, he states that he has given an aggregate of thousands of treatments in a large number of cases, and that while there have been failures, the method has as a rule given excellent and in some instances remarkable results.

---

<sup>1</sup>Neurasthenia and Its Treatment by Actinic Rays, *Journal of the American Medical Association*, Feb. 20, 1904.



In the treatment of locomotor ataxia and other constitutional diseases, the results from the use of the chemical frequencies of light have been more satisfactory than any other method, and he states that he has used almost every method of any worth whatever. But in neurasthenia and other debilitated conditions, the best results have been obtained at his hands from this method. They have been almost uniformly excellent, very few if any failures occurring. And not only were the results individually good but the duration of treatment has been materially lessened, in some instances to fully one half. This he stated was very clearly evidenced from a comparison between the length of time patients remained at his sanitarium now and formerly.

Foveau de Courmelles found that in some cases facial neuralgias and cutaneous hyperæsthesias, which in general yielded to blue light, were made worse by blue light, but that they promptly yielded to the activities of the electric arc. Courmelles notes, in passing, the well-known power of the X ray to cause sudation in similar cases; also high frequency currents, all of which are similar physically and physiologically.

The author has found the action of both incandescent and arc light of value in the treatment of severe neuralgic conditions and reported in 1894,<sup>1</sup> relief in a neurasthenic patient, who was suffering from severe neuralgia of both cervico-occipital and supraorbital nerve distributions. The relief established at a single sitting lasting for several hours.

Dr. Julius Rosenberg<sup>2</sup> collates a number of cases, in reviewing his experience with phototherapy. He is of the opinion that in light a remedy of no mean order is to be had and one which in the near future will occupy a most exalted position; the possibilities of its curative action are still unknown.

---

<sup>1</sup>Report of Committee on Light as a Diagnostic and Therapeutic Measure. American Electro-Therapeutic Association, 1894, Transactions Am. E. T. Association, 1894.

<sup>2</sup>N. Y. Med. Journal and Phil. Med. Journal, April 23, 1904.

For a source of energy he uses a 55-ampère iron carbon arc. He regards the high ampèrage necessary and the specially prepared carbons. The divergent rays are collected by the mirrors of the apparatus, enabling him to throw and concentrate the light upon a given point. Exposures are from 55 to 75 minutes; a shorter application he regards as not of lasting benefit. In a sensitive skin the expenditure of so great an energy and one so rich chemically over so prolonged periods may produce an erythema but with ordinary care he does not find that it either produces blisters or other injuries. The treatment as a rule is not unpleasant, but indeed affords relief from any pain from which the patient may be suffering and is therefore gratifying both to patient and physician.

Rosenberg reports 20 cases as follows: Neuralgia in right breast 7 weeks' duration, usual classical treatment, recovered under 2 applications of light, duration 55 minutes. Severe neuralgic pains originating in left ovary in patient 5 months pregnant, locomotion difficult and painful, relieved entirely by 2 light treatments. Intercostal neuralgia, 4 years' duration, constant pain, varying in severity, treated by Rosenberg for years with but little relief, disappearance of pain after third treatment by light, no return after 2 months. Coccodynia, from traumatism, miserable for a year, unusual tenderness at sacro-coccygeal articulation, no abnormal condition of rectum or genitals, relieved considerably after first treatment, free from pain after 2 weeks' treatment.

Ovarian neuralgia, left for years, organ enlarged and tender. Local treatment, tampons, etc., without much relief. Patient relieved by first treatment. Apparently cured after 5 exposures; ovary smaller and no longer sensitive. Injury 5 years since, patient fell upon buttocks, since pain and tenderness in lumbar region, especially left side, very miserable last summer, spasms of erector-spinae, producing temporary spinal curvature; massage and continuous current of no benefit, seen in consulta-

tion by nerve specialist, who advised Paquelin cautery to be applied and rest in bed. Slight improvement resulted but patient never free from pain. Pain much worse 3 weeks previous to report, considerable distortion of the spine, unable to turn in bed, as the slightest exertion caused extreme agony. Relieved by first treatment, and after 5 treatments the patient was free from pain and able to be about. The remaining 13 cases include a sciatica of several years' duration, apparently cured after 9 applications; a neuritis, musculo-spinal of 4 months' duration, all remedies tried, morphine in  $\frac{1}{2}$  gr. doses gave transitory relief; completely relieved for 8 hours from first exposure and went to sleep for the first time in weeks without opiates. In all 12 exposures were made, and at time of report the patient was able to attend to business, no longer using opiates and with the exception of a slight rigidity no pain or discomfort. The remaining cases are of much the same character and were relieved with the same celerity. Two cases of tic douloureux will serve to complete a very interesting clinical report. Mrs. —, a facial neuritis of 6 years' duration, untold agony, most of her teeth had been removed also her lower jawbone. First seen 5 weeks prior to the report, could barely speak, every movement of the jaw painful, sharp shooting pains, a typical picture of tic douloureux. The first treatment produced a wonderful change in her condition, she left the office free from pain, and a treatment every third day had kept her comfortable. She sleeps without opiates and is able to receive the much needed care of a dentist. The case was not regarded as a cure but in a few weeks, even days, results had been obtained, which years of medication and operations had failed to secure. Mrs. S. F. Tic douloureux for 10 years, division of the nerve at various points afforded either no, or only temporary relief. Applied for treatment by advice of family physician, in the greatest agony. Temporary relief from exposure to the light but pain returned with undiminished severity whenever they were removed. Treatment discontinued after the third

treatment on advice of a nerve specialist, who stated (?) "that the treatment if continued would cause burns and brain injuries."

In a boy of 10, twitching of facial muscles since infancy, the spasms had almost entirely ceased after 7 exposures, the light being directed to the occiput. Neither cure nor improvement was expected and Rosenberg states that had the boy been an older subject, the possibility of hypnotic suggestion might have been considered.

These detailed cases of Rosenberg's are corroborative of the writer's experience with the treatment of similar cases by the electric arc light energy for the past 11 years. Recently, concentrated light, deprived of all the thermal frequencies, has been used successfully (1) to relieve extreme cerebral congestion, one application 10 minutes in duration made to cervical cord with compression, (2) localized pain and soreness as a sequence of spinal hemorrhage, followed by complete paraplegia; partial recovery but incontinence of urine, one application 10 minutes in duration and (3) in a case of severe neuralgia involving all the nerves of right side of neck, face and occiput secondary to mastoid congestion following la grippe, one exposure 5 minutes in duration. The painful area in the case of spinal hemorrhage was relieved at once. The case of cerebral congestion slept all night after the treatment for the first time in many weeks and returned to the office the following day with lessened circulatory disturbance, facial tissues normal as to circulation (had typical belladonna face and great mental confusion), quiet mien and consecutive thought. The improvement established has continued for 3 months. Subsequently several other applications of concentrated light were used, also the convective discharge from the influence machine. In the case of neuralgia, the application was made just behind the ear. An erythema developed in 20 minutes, increasing in severity for 24 to 36 hours, the sensation being that of a burn. During this reactionary stage, the suffering was increased, the sensation being that of extreme congestion and

as though every nerve trunk and branch was held in a vise. With the subsidence of this stage, improvement began and has been continuous. The severe supraorbital, ocular, and aural pains have passed and do not appear under the influence of cold, damp, and fatigue as they did, while the neck muscles, which were not only sore but stiff, are practically normal. This stiffness of the neck muscles had lasted for 6 months prior to treatment, and at this writing, 3 months later has not returned nor have the evidences of the action of light, i.e., pigmentation disappeared. Exfoliation took place in about ten days. There has been some return of the pain on exposure to cold, damp or fatigue, but at no time has the pain been so severe as before, and especially is this true of the aural pain.

The same method has been used with great improvement in a case of incontinence consequent upon a spinal hemorrhage and complete paraplegia. In 11 weeks' time there has been a daily increase of control and from almost daily and many times a day incontinence she has been free from any trouble about two-thirds of the time. At this writing she continues to improve.

Other than the action of the chemical light frequencies on the blood there must be an immediate action upon the peripheral nerve endings, judging from the prompt and speedy relief from pain.

The biological action of light is one which yet requires much study and investigation that it may be known how it acts. The fact of the absolute dependence of the human species for existence upon solar energy is not only because of the dependence of the former upon the vegetable kingdom, but it presupposes as well a definite relation between its action and the functions of the human organism.

The Use of Light in Diabetes.—Both the incandescent and arc light have been employed to advantage in the treatment of diabetes, but because of the greater chemical activity of the arc, it is the better form of light to use.

Recently Strebel<sup>1</sup> has reported the results obtained by him in the treatment of a series of cases of diabetes by means of the electric arc. As per the method of Monbinow, he utilized a 25-ampère arc at 60 volts; reflecting the luminous rays upon a parabolic mirror from which they were directed upon the hepatic area. Under the influence of the light activities, the skin reddens rapidly, becoming the seat of local sweating, which may become general, if the source of light is brought nearer and if the general direction of the beam of light is reflected perpendicularly to the cutaneous surface. A rapid diminution of sugar was noted after several days' application, and finally its complete disappearance. While the results obtained by Strebel are most encouraging, they are not yet numerous enough to judge of the comparative value of the method.

The energy of the electric arc is better adapted to the needs of diabetic patients than that of incandescent lamps. It is the chemical rather than the sudative action which is desired primarily.

In chlorotic women there seems to be a congenital weakness of the blood-forming and blood-propelling apparatus, the cause of which is to be sought for in some faulty condition of the meso-blast. In them, the heart and the blood vessels are small and the absolute number of corpuscles may be diminished one-half, although the relative number may be retained, while in the corpuscles themselves the hæmoglobin is diminished almost one-third. This quantity of hæmoglobin rises after the administration of iron and other remedies and also is improved to a degree by an expenditure of various forms of electrical energy. But in the well-marked and more obstinate cases of this sort, as well as in secondary anæmias, the author has found an exposure of the entire nude body to the radiant energies of an electric arc bath of greater avail than the exhibition of drugs singly or in combination, an expenditure of electrical energy or that from water in the

---

<sup>1</sup>Light in Diabetes: Review Internationale d'électrothérapie et radiothérapie, January, 1904.

recognized hydropathic administrations. The waxen pallor, the breathlessness, the inadequate heart, the palpitations, the puffiness or œdema of tissues, the lack of strength and inability to go up and down stairs have either disappeared or become modified under the influence of an electric arc bath, with great rapidity. There has been an increase of hæmoglobin under the influence of the light, by reason of the stimulation imparted to the swing of the oxygen atoms. For as each condition of matter when its corpuscles are vibrating at their own characteristic rates causes different sets of waves varying in lengths, amplitudes and periods of oscillation<sup>1</sup> in the physical world, so in the human organism must the characteristic vibrations of atoms or molecules cause different sets of waves, varying in length, amplitudes and periods of oscillation and the propagation of these ultimately influences the entire blood stratum, resulting in its enrichment with normal constituents.

In all the conditions enumerated showing a departure from the normal characteristics of the red blood corpuscle, the author has found the therapeutic use of light of very great avail, with the exception of pernicious anæmia. The opportunity for treating such a case has never appeared, and even if it did, there is very great doubt as to whether any good result would ensue. Still, should the opportunity present itself, the effort would be made, for unquestionably it is the red blood corpuscle which must be acted upon in an attempt to secure a favorable result. Drugs do not avail. In the stimulus imparted by the absorption of the chemical frequencies, it is possible that the abnormally sized, irregularly shaped, and improperly distributed red blood corpuscles might assume normal shape, volume, coloring, consistence and distribution. This, however, is conjecture, and is not supported by clinical experience.

It has been stated that the action of iron administered internally is much more energetic when the nude body is

---

<sup>1</sup>Larkin: Radiant Energy, p. 51.

exposed to the action of light. The author has made no experiments in this direction, but it seems well worth investigating. The many different rates at which the oscillating corpuscles of iron vibrate, taken in connection with the physical and physiologic action of light waves upon the human organism, afford ground enough for advancing the hypothesis. Iron has a great affinity for oxygen, so also have ultra-violet frequencies. Is there a sympathetic resonance or synchronous vibration produced between the presence of the one within and the other without?

The rational hypothesis of the action of light stimulus in syphilis, not only upon the superficial lesions, but the systemic condition, is based upon its pathology of sub-oxidation.

The function of all organs so far as the effect is concerned is carried on by the plasma, the plasma depends upon the hæmoglobin for its reserve energy or oxygen, and the red-blood corpuscle is able to store a large reserve in the hæmoglobin compound.

Under physiological conditions, the plasma of the blood is the circulating fluid within the axis cylinders, and the surrounding semi-fluid media or the myelin around the axis cylinders, the white matter of the cerebro-spinal system. The reaction of nerve structures to methylene blue is due to oxygen saturation and alkalinity of the blood. In *tabes dorsalis* it may be possible that the normal oxygen saturation of the nerve structures is not maintained. The indication, therefore, in therapeutics is for a measure which will increase the oxygenating power of the blood in order that the red blood corpuscles may store up oxygen. At the same time the production of a more or less lasting hyperæmia of the degenerating cord is indicated.

The influence thus exerted can after all only be limited, and depends upon the extent to which the degenerative process has extended.

Clinical evidence points to a more than palliative influence in this condition. Just so far as the oxygenating



power of the blood stream can be maintained, and a hyperemia of the intimate circulation of the cord secured just so far it is possible to combat the progress of these degenerative changes. By the action of light energy there is established a dilatation of the cutaneous vessels which determines a more active blood supply to the part. This, in turn, must be assumed to favorably influence nutrition, enabling the skin, and even deeper tissues for that matter, to perform their functions.

Locomotor Ataxia.—There is a considerable clinical evidence pointing to an actual improvement in this condition, and to an arrest of the degenerative process by the action of light energy.

The physician whose case is detailed below is known to the author personally. The history was one of extreme suffering and disability. It is very probable that the injury was the predisposing cause with the specific infection the exciting cause. In addition to his tabes he was a typical neurasthenic. Suffice it to say that up to the time of his using the electric arc light he was in a most pitiable condition. At this writing he is in a fair degree of health, does not suffer from pain, functions are well performed, and after he once has started to walk the ataxic gait is but little apparent.

C. C. G., physician, age 46, tabes. When riding on April 18, 1892, while making professional calls, his horse became frightened, overturning the buggy, and breaking both bones of the left leg below the knee, at the same time severely wrenching the lumbar articulations. The recovery from the fractures of the leg was prompt and uneventful, but the disturbance in the back persisted. During convalescence he suffered constant throbbing pain at the site of the injury in the lumbar region, pronounced pains occurring alternately at different points for the entire length of the spine, indicated the establishment of a diseased process throughout the cord. The pain was always aggravated by physical activity, and also by mental worry and annoyance. At this time a great demand was made upon him in

the care and attention he gave his invalid wife, who died June 20, 1895. The extra care, anxiety and grief increased his physical disability. After her death he suffered from insomnia, and finally developed the unmistakable symptoms of locomotor ataxia. In the late summer or fall of 1895, preceding the loss of the patella reflexes, there was induced a diminished or lost sensation of the nerves of the third toe of the left foot. Beginning at this time he experienced severe lancinating sensations in his extremities with "girdle sensations" about the chest. There also appeared the usual sensory disturbances of heat and cold, while the pains in the back grew more severe and were continuous. The usual disturbance of the intestinal function was also experienced, which was followed by ulceration of the sphincter ani. This was in turn followed by stubborn, uncontrollable, diarrhoea, with from one to 20 movements daily. The patient suffered from urethritis, cystitis, prostatitis and incontinence of urine in an aggravated form.

In the spring and summer of 1896 the pains became general, being no longer limited to the lumbar region and lower extremities. They would be severely felt in one location for an hour, or possibly for a day or so at a time, and then change to other parts of the body.

The pain in the back continued from the date of his first injury, April 18, 1892, till about the first day of May, 1893. A specific history in this case is very doubtful, the only lesion which can be associated with the possibility of such a condition occurred in the summer of 1894. An ulcer formed over the phalanx of the left thumb. It was characterized with a thick, heavy, indurated base, and resisted the ordinary methods of treatment, requiring from 6 to 8 months to heal. There was never any other evidence of specific trouble, and no secondary symptoms or tertiary lesions ever appeared. This sore was the only evidence of syphilitic infection.

The treatment administered for the locomotor ataxia was begun in the summer of 1896, and was as follows: iodide of

potash was administered in quantities as large as 600 grains daily. Following the use of the iodide strychnia was given in doses as large as  $1/20$  grain, 3 times daily. All these measures accomplished nothing. The patient grew continually worse until 1898, when he became almost helpless. From this time no drugs were taken, as the patient felt that medicinal treatment aggravated his condition. After carefully trying sanitarium treatment, where various plans and methods of treatment were adopted, he became discouraged. He then began the use of suggestion in the spring of 1900, but during this time the syndrome remained unchanged, pain and other ataxic conditions persisting regardless of treatment. He, however, improved remarkably in his locomotion by the methodical use of a system of exercise (Fraenkel) to re-educate his muscles. Under this he gained some flesh and strength. There was not, however, any improvement whatever in the progressive symptoms of the trouble, the cord lesion.

About March 20, 1903, treatment was instituted by means of an electric arc light bath. These baths were given in a cabinet about  $5\frac{1}{2}$  feet long,  $4\frac{1}{2}$  feet high, and 3 feet broad, with an arc light suspended on either end; the space between the 2 lamps being from 3 to  $3\frac{1}{2}$  feet. With these lamps there was used a special carbon of German manufacture,<sup>1</sup> known commercially as the plain blue carbon. Exposures were made daily for from 30 to 40 minutes, during a period of 4 weeks. At this time he had lost a few pounds in weight. The exposures were administered on alternate days for 2 weeks, and then every third or fourth day for about one month. During this period the improvement was remarkable. Following the first few exposures there was marked relief from the severe, lancinating pains from which he had up to this time suffered. Relief from the girdle sensations, gastric crises and digestive disturbances was experienced from the first, and there was also marked improvement in

---

<sup>1</sup>Mfg. by C. Conradi, Germany.

the incontinence of the urine from the first. The relief established has continued. At the end of 6 weeks' treatment he was enabled to rest almost an entire night without vesical disturbance. The diarrhœa also improved, and there was also a marked improvement from the first in locomotion and co-ordination. Reflexes are still abolished. Since the close of this course of treatment the attendance has been less regular. The patient averages 2 treatments per week at the present time. His improvement in every way is remarkable, almost, if not quite unprecedented. The doctor<sup>1</sup> has treated several cases since his own recovery with similar results.

Alternating-Current Electric Arc Baths.—For an arc light bath where uniform and extensive diffusion of the light is desired to act upon every part of the superficies of the body, the alternating current is of especial value by reason of the fact that the distribution of light has two planes of maxima of intensity, one above and one below the horizontal plane. This is very clearly shown in Fig. 10,

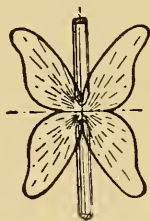

Fig. 11.

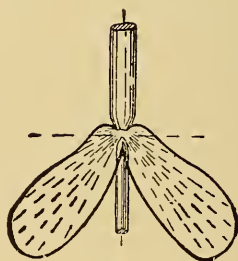

Fig. 12.

where the luminous intensity is seen to reach a maximum about  $50^{\circ}$  both above and below the horizontal plane.

The contrary is true of the luminous intensity of a continuous-current arc, as is shown in the second illustration.

---

<sup>1</sup>For the detailed history of the case, the author is indebted to the patient himself.

Very little of the luminous intensity of a continuous current arc is produced in the regions above the horizontal plane passing through the arc. The intensity rapidly diminishes as we descend below this horizontal plane, until at an angle  $75^{\circ}$  below very little light is emitted. It will be recalled that in the arrangement of the continuous arc light mechanisms in the author's cabinet the greatest intensity of light falls upon the body of the patient as they recline upon the couch within the cabinet.

From Fig. 10, it can readily be seen that from the use of alternating-current arc light mechanisms, when the patient is in a sitting position, the entire superficies of the body will be brought under the influence of a very evenly distributed light energy; but with continuous-current arcs, a recumbent or semi-recumbent position exposes the body to the greatest intensity of the light energy.

In this direction of the luminous intensity is to be found the reason for placing tubes with focal lenses, as in the Finsen apparatus, in an obliquely perpendicular position in relation to the source of light, and also the reason for allowing the light energy to fall perpendicularly upon the parts to be treated.

More recently Dr. Albert E. Sterne<sup>1</sup> has reported the use of a somewhat complicated cabinet containing alternating-current arc light mechanisms. In it he has placed a device for the generation of ozone and a Tesla coil for the purpose of utilizing the high frequency discharge at the same time. The individual operator can arrange a similar device if he so desires.

Since the value of light alone as a therapeutic measure in a given class of cases was established by the author it has always been customary to follow a light bath by an administration of the convective discharge from a static machine or a high frequency current. This was not done in the beginning of the use of light, but after a sufficient clinical data

---

<sup>1</sup>Journal of the American Medical Association, Feb. 20, 1904.

had been amassed to determine the action of light energy alone.

The more simple and uncomplicated apparatus lends itself to the needs of the average practitioner and an electric arc bath may be arranged by the individual physician which need neither be elaborate nor expensive in construction.

## CHAPTER X.

**Incandescent Light Baths.** Arrangement of Light Mechanisms, Methods of Use, Therapeutic Indications. Obesity, Gout and Rheumatism, Diabetes, Anæmia and Chlorosis, Toxæmias, Nephritis.

### **Incandescent Light Baths.**

**Incandescent Light for Therapeutic Purposes.**—The selection of a source of light energy and its arrangement depend entirely upon the purpose to be attained. In practical work the indications for the energy from these different sources is not always absolutely clear and well defined. They touch at many points just as in an expenditure of electrical energy or for that matter of chemical energy as with drugs. But from a knowledge of the physical properties of incandescent light, i.e., its spectrum and from its physical effects and physiological action, the conditions in which it is useful can be very clearly established.

**Principles of Construction of Incandescent Electric Lamps.**—The principle utilized in the construction of an incandescent light is familiar to all, viz., that when a strong current of electricity is passed through a wire of small conductivity, i.e., high resistance, its temperature is raised to incandescence. If the strength of the current is increased, the brightness of the light increases, but in a greater ratio than the strength of the current. At such high temperatures, wires, even of the metals fused with the greatest difficulty, fuse readily or are disintegrated. The only substance which does not fuse at the highest temperature is carbon. The first lamps in which carbon was used were constructed independently by Edison and Swan in this country. To Edison, however, the credit is due for finding a material from which high-grade carbon filaments are made. This is a

special kind of bamboo, carbonized at high temperature in closed nickel moulds. By enclosing an electric light in an opaque calorimeter, the entire radiation is absorbed, then if afterward it be surrounded by a transparent calorimeter, permitting the light to pass, it will be found that the luminous radiation is about 10 per cent. of the total in the case of the electric arc and but 5 per cent. in an incandescent. The relation between the lighting power and the strength of current varies in different lamps according to the strengths of the current.

**Ampèreage and Candle-Power.**—A 16 candle-power Edison lamp requires a current of 0.6 ampère. As its resistance when hot is 170 ohms the potential difference at the connection according to Ohm's law would be the current multiplied by the resistance or  $0.6 \times 170 = 102$  volts.

**Life of Incandescent Lamps.**—Under normal conditions the life of an incandescent lamp is from 1000 to 2000 hours, but it depends chiefly on the strength of the current passed through it. The life of a lamp is shortened if the current is very strong but the illuminating power varies in greater ratio than the current. Bulbs which have been used over long not only lose their normal illuminating power but require a greater amount of current to produce that power. Therefore they should be changed in incandescent light cabinets the minimum length of time rather than the maximum.

**Efficiency of Incandescent Electric Lamps.**—The efficiency of an electric lamp is generally given in the number of watts required to produce one candle-power. An incandescent lamp may absorb from 3.5 to 4 watts per candle, an arc light is much more efficient, as it gives one candle at the expense of less than one watt. The incandescent lamp bulbs on the market to-day are many of them inferior to those used several years since. They are more cheaply constructed, of shorter life and less efficiency. They therefore require to be changed frequently, for in an incandescent cabinet containing 50, 75 or 100 incandescent lamp bulbs, the amount of current consumed in a busy office hour is considerable.



Incandescent Light Bath—Largely a Thermal Bath.—The incandescent electric light bath is very largely a thermal bath, as the luminous efficiency is but 5 per cent. of the total output, but a cabinet equipped with 50 or 100 of such lamps gives, after all, a very large luminous output. In this per cent. of luminous frequencies all are to be found from the violet down to the red, and as they all possess greater or less chemical power, there is after all a very large chemical efficiency to an incandescent light bath. The chemical activity of the long, slow and less highly refrangible frequencies is sufficient to counteract any depressing effect of the thermal frequencies.

Spectra of Incandescent Light Similar to Spectra of Petroleum and Gas.—The incandescent light has a very similar spectrum to that of petroleum and gaslight. It is poor in violet and blue frequencies, and rich in yellow, red and green. Of the three, sun baths, electric-arc baths and incandescent light baths, the latter occupies the third place in so far as chemical light energy is concerned. Sunlight is richer chemically than the incandescent in the blue-violet frequencies, while the electric arc is much more intensely chemical as it is used, than even sunlight, because of the ultra-violet energy which it emits, and which can be used so near the light source.

Chemical Efficiency of Incandescent Light Spectra Increased by Increasing the Current.—The chemical efficacy of incandescent light as evidenced photographically is, therefore, very slight, but this, as well as its luminous output, may be materially increased by increasing the current.

This is shown by Abney's table.

Number of Grove Elements.	Illuminating Power in Normal Candles.	Photographic Effect.
12 .....	0.132 .....	immensurable
14 .....	0.26 .....	0.35
16 .....	1.17 .....	1.61
18 .....	2.44 .....	5.83
20 .....	3.84 .....	12.84
22 .....	6.85 .....	36.45
24 .....	10.38 .....	86.60

It is not only the luminous output or optical brightness that is affected by increasing the strength of the current, but also the quantity of blue and violet frequencies.

Chemical Equivalent of Incandescent Light.—It is estimated that, as a rule, 380 incandescent lamps of normal power without reflectors have the same chemical effect as natural light, at a distance of one metre from the object.

The Nernst Lamps for Incandescent Light Baths.—In the Nernst lamp there is to be had a light richer in chemical frequencies than the ordinary incandescent lamp. By their use a light twice as intense is obtained of a pure white or rather greenish color, and, therefore, more from the chemical end of the spectrum. Of all the electric energy consumed in an incandescent light bath, but 5 per cent. is accounted for in the luminous activities. This does not include the red, blue and violet frequencies, which bring it up to 30 per cent. With the Nernst  $\frac{1}{2}$ -ampère lamp, this percentage is raised even to 60 per cent.

The Radiant Efficiency of the Nernst Lamp.—The efficiency of new Nernst glowers was found by Ingersoll,<sup>1</sup> who carefully tested them to vary from 4.35 per cent. to 4.70 per cent., with a mean of 4.61 per cent. The efficiency falls rapidly for the first 20 hours, decreasing to 4.3 per cent., but varies only very slowly after this. In making these experiments Ingersoll maintained the power constant, not the current, as was done by Hartman, which accounted for his different figures as to decrease in the efficiency. Some very old lamps tested gave efficiencies of only 3.6 per cent. The lamps were all 110-volt glowers, consuming 89 watts, and for every watt above 89, within narrow limits, the efficiency increases 0.06 per cent., and below this, vice versa. The energy curve (Wiens law) gives the efficiency as 4.17 per cent. These tests were made in such a manner as to cut off all the invisible frequencies, giving only the radiant

---

<sup>1</sup>The Physical Review, Nov., 1903.

efficiency of the lamp. In common with the incandescent old lamps lose their efficiency, and in baths constructed either with the one or the other, the lamps should be renewed frequently. This not only means greater efficiency but less consumption of current.

The Nernst lamp, by reason of the fact that it does not require a glass covering, although provided with one, offers a means of supplying the frequencies needed in therapeutic work, although not to the same extent as the arc, still greater than the incandescent lamp. In this lamp the source of the light is a rod of zirconia acted upon by the electric current. As there is no glass enclosing bulb, there is no loss of the short and high frequencies, as in the incandescent. For a therapeutic cabinet it is useful and fewer of them would be required, owing to their greater efficiency. Still another advantage over incandescent bulbs, is that for the same consumption of current the number of light waves is greater, as less of the current is converted into the longer heat waves.

First Introduction of Incandescent and Radiant Heat Baths.—Incandescent light baths were first introduced by Kellogg and the radiant heat baths by Hedley. In 1894 Kellogg presented a paper to the American Electro-Therapeutic Association, giving a very exhaustive résumé of his work with incandescent light baths. About the same time Hedley, of London, called the attention of the Balneological Society to an apparatus which he had devised for the purpose of applying to the body direct heat rays from a luminous source.

Winternitz has particularly interested himself in the development of this therapeutic measure.

Hedley's device consisted of incandescent lamps, each carrying  $2\frac{1}{2}$  ampères of current, fixed in reflectors. This apparatus has been in use ever since. The well-known Dowsing radiant heat baths are constructed upon this principle. The devices of both Hedley and Kellogg have fully stood the test of time. The fundamental principle in the construction of baths for this purpose is the same in every

instance. These cabinets were subsequently introduced into Germany by the chemist Gebhard, where they are very extensively used.

**Incandescent Light Mechanisms.**—Incandescent light mechanisms may be arranged for either general or local work. In the former instance, cabinets are constructed on the principle of the Kellogg cabinet, and the energy of varying numbers of incandescent lamps from 50 to 100 or more utilized therein. Kellogg's first use of incandescent light energy was with single lamps where the energy was localized and concentrated. This method is considered in detail in Chapter XIII. The results obtained from their use in this way were so excellent that he was led not only to the grouping of a few lamp mechanisms for the purpose of concentrating the light energy upon a part, but to the construction of an apparatus for the exposure of the entire nude body.

**First Incandescent Light Cabinet.**—His first cabinet consisted of a frame about 2 feet in width, which supported a metal reflector and from 20 to 30 incandescent lamps. The frame was attached by hinges to a support in such a way that it could be raised or lowered at will. The patient was exposed in a recumbent position upon a couch placed beneath it during the time of treatment. When the one surface of the body had been exposed for a sufficient length of time, the patient turned over exposing the other side of the body to the light energy. Later on he had cabinets constructed at first a vertical and then a horizontal one. These cabinets are constructed at this time of different forms and sizes according to the needs of the individual practitioner.

Incandescent baths may be arranged either for a sitting or a recumbent position of the patient. The principle is the same in each instance. As a rule, they are arranged for the sitting position, although one of the Kellogg cabinets is arranged for the recumbent position.

**Horizontal Incandescent Light Bath.**—In this the patient reclines upon a glass-covered couch, while from above

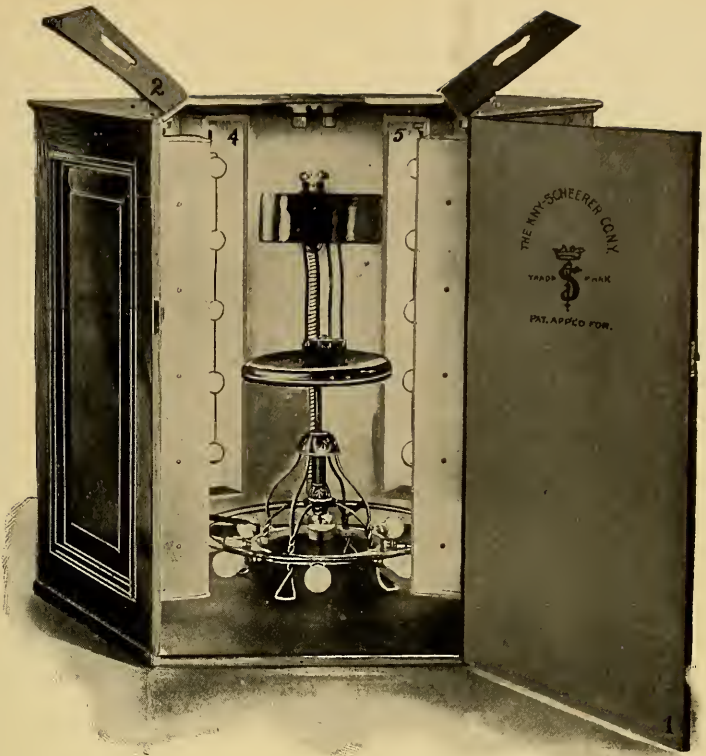

Fig. 13.—Incandescent Cabinet Open.

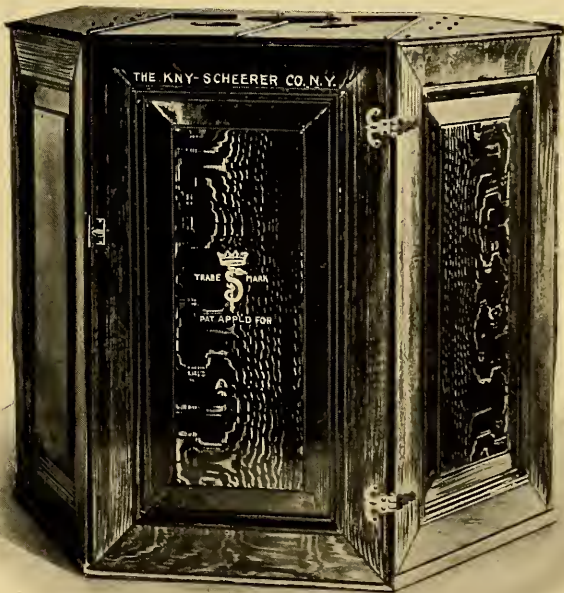

Fig. 14.—Incandescent Cabinet Closed.



him and below him, and also on every side of him, the energy of about 100 16-candle-power incandescent lamps, reflected and multiplied by polished mirrors, is directed to the body superficies. The couch is movable, mounted on wheels, that it may easily be run in and out. The glass covering of the couch permits the action of the light energy upon every square inch of the exposed body. Here there are no limiting ultra-violet frequencies to prevent the use of the glass. The head remains outside of the enclosing cabinet during treatment while a curtain shields the patient's eyes from the action of the light.

The vertical cabinet described by Kellogg, required to energize it from 20 to 40 16-candle-power lamps. Different operators vary the number according to the conditions to be met.

These incandescent light cabinets generally, however, consist of octagonal boxes arranged for connection with the street electric wires. They may be operated either by a continuous or an alternating E. M. F., and the one is as good as the other for the purpose. They are variously supplied with mirrors, opalescent and colored glass plates, to be used at will. A door permits the ingress and egress of the patient, who in the enclosing cabinet sits upon a stool. There is also a movable divided lid fitted on the top with a hole the size of the patient's neck, and from which the patient's head emerges. The cabinet shown in the illustration is one of the most complete cabinets constructed by the manufacturers for the purpose of an incandescent light bath. As will be seen it is a cabinet in which the patient sits with the head out while exposed to the action of the light energy. The framework is constructed exclusively of steel. This completely obviates any danger from fire in the event of a defective bit of insulation. It is provided with 38 lamps, and consists of 6 drawn sheet steel panels, steel top with head and hand holes, steel bottom, metal chair, with door at front and 2 doors in the top, as shown in cut (Figs. 1, 2 and 3).

Thirty spherical incandescent lamps are arranged in 6 channels (Figs. 4 and 5), said channels being provided with violet or ruby glass screens, which are hinged to one side of the said channel, and so arranged that they may instantly be changed or opened to give access to the lamps within. Eight lamps are also arranged around the bottom of the chair. Each set of lamps is on an independent circuit, and each may be controlled separately by means of switches conveniently arranged on the underside of the top of the cabinet. In this manner the temperature within the cabinet may be closely regulated.

All wiring is of the latest approved style, enclosed in steel tubes, and such as approved by the New York Board of Fire Underwriters. The wiring is so arranged that the cabinet may be operated on 52 or 104-volt alternating current, or 110 or 220-volt direct current. To this end it is merely necessary to insert lamps of the equivalent voltage.

The simplicity of the construction of this cabinet is such that it can be set up in a few moments by any one following the directions.

The channels carrying the lamps are supported on hooks at their back, and the lamps therein connect to junction boxes on the underside of the top of the cabinet by means of plug switches. The panels are held in place by small clamps, which also serve as a support for said lamp channels.

To facilitate shipment and simplify the installation of the cabinet by a novice, it is so constructed that it may be entirely taken apart without interfering with any of the electrical connections or other parts.

This is accomplished by removing the plug switches at the top of the channels, lifting the top off, raising the channels from their hook supports, removing the screws in the clamps holding panels together, and withdrawing the two hinge pins. In setting it up the reverse of the above direction must be followed.



Dr. Italo Tonta<sup>1</sup> made several improvements in his incandescent light bath, which are worthy of attention. First he provided the top of the octagonal-shaped cabinet with a cupola-like cover, with angles so disposed that it is possible to concentrate the light energy upon the body of the patient. In one of the posterior faces of the cupola he has provided a ventilating device operated by a small electric motor, the speed of which is controlled by suitable resistance, as he regards the want of ventilation in an ordinary cabinet a great fault. In the thickness of the 2 lateral doors below are 2 openings the size of the palm of the hand closed by small metallic plates which are provided with mirror surface upon the inside. Those are for the entrance of dry air, which can be introduced into the cabinet when the ventilator is in action. When these are closed and communication established between the ventilator and the external air the hot air inside the cabinet is agitated. Seven circuits of a series of 8 lamps each are provided. These are placed horizontally. The last circuit comprises 2 lamps placed under the bench designed for the feet. Screens of different colors are provided to eliminate at will different frequencies of the spectrum. The roof of the apparatus is provided with a groove in which the cover, divided into two parts, glides. This is so arranged as to fit exactly about the neck of the patient. In this cabinet the refraction of the light is horizontal and diagonal. The walls of the cabinet are of wood, covered upon the inside with mirrors. In the fixed part of the cover a thermometer is placed in a neutral zone, i.e., a part that is not exposed to the direct radiation of the light. There are provided openings in the walls of the cabinet for the purpose of observing the cardiac movements, and at the same time of the condition of the skin as to transpiration and by an introduction of a hygrometer to estimate the humidity of the air. These can be opened or shut at will. An adjustable chair within the

---

<sup>1</sup>The Light Bath Congress of Electrology at Berlin. *Revue Internationale d'Electrothérapie*, Nov. and Dec., 1902.

cabinet permits the patient to be placed at the desired height. This detailed description is given because the apparatus has many good points. The individual operator can have all these details of construction embodied in his incandescent light cabinet if he wishes.

The method of ventilation the author regards as extremely advantageous.

Combined Incandescent and Arc Light Cabinets.—Sometimes these cabinets are constructed in such a manner as to contain both incandescent and arc lamps to be used simultaneously or separately, as the operator desires. While combination incandescent and electrical arc baths are not recommended they can be used where floor space prohibits the placing of two equipments. They should be so constructed that either the light energy of the incandescent or that of the arc can be used separately or conjointly, as desired. The action of the incandescent bath, as compared with that of the electric arc, is to be regarded as that of thermal energy, while with the electric arc bath the action is primarily a chemical one.

The author prefers to project the light from an arc light mechanism provided with suitable reflecting mirror, as the marine searchlight, upon the patient seated within or without the cabinet, according to the environment rather than to have electric arcs permanently placed in an incandescent cabinet.

Effects of Incandescent Light Baths and Electric Arc Baths not to be Confounded.—The effects of these should not be confounded with the effects of electric-arc baths. The latter whether used in such a way as to secure the influence of all the activities of the arc, or the exclusion of the thermal frequencies, is in the highest sense a chemical light bath because of the exceeding richness of the electric arc in the chemical frequencies. The latter is richer in the ultra-violet than the sunlight as we use it, while the former is not even comparable chemically with sunlight. But even so, the incandescent baths occupy a very important place

in therapeutics. They are useful by means of their radiant heat, in addition they have a chemical power by reason of the blue, indigo and violet frequencies, for which the glass is transparent. As a source of light the incandescent lamp is not rich in these frequencies, but as the glass does not preclude the passage of those emitted, and as many of them are used in a given light bath equipment, from 25 to 100 or more, it follows that after all an incandescent light bath has a very decided chemical power. It is more than a sudatory or transpiration bath, and even so, as such, the heat produced is of a different quality from that which proceeds from hot air or steam. A number of these gathered together in a small area, as in a therapeutic cabinet offer very great chemical power. Even a candle as a source of light has sufficient chemical power to render it necessary to use a dark red glass in the examination of a sensitized photographic plate.

Advantages of Incandescent Sudatory Baths over Hot-Air or Vapor Baths.—The advantage of these baths as sudatory or transpiration baths is to be found in the fact that heat reaches the interior of the body by conduction, after penetrating slowly through the layers of the tissues that oppose by their inherent construction, a great resistance to the passage of heat rays, but allow light waves to pass readily. With an incandescent light bath, even though applied as a sudatory bath, in conditions where profound elimination through the skin is desired, in Bright's disease, for example, the time of application is much shorter than with the hot air or the vapor bath. This is due to the fact that in addition to the thermal activities there is an influence also of the longer and slower frequencies; the red, yellow and green, as well as from the more refrangible blue-violet up to the ultra-violet. There is a very small per cent. of blue-violet emitted by a single incandescent unit of light, however. The red and low frequency waves are transformed into heat, while the higher visible chemical frequencies exercise (1) their characteristic action upon the skin and superficial circulation and (2) upon metabolism.

An incandescent light bath, then, is active by reason of its thermal, luminous and visible chemical frequencies. The latter are much less than in the sun or electric arc, therefore where the maximum chemical effect is desired in a general bath, either the sun or the arc should be selected.

Penetration, Absorption and Transmission of the Varying Frequencies of Light Energy by the Living Tissues.—Kellogg found “upon examining by means of the splanchnoscope a human body on whose abdomen a single incandescent lamp of 16 to 32 candle-power was burning, the whole true pelvis shown with a bright red light.” As noted on a subsequent page, a miniature incandescent lamp within the vagina will cause the pelvic tissues to within 2 inches of the umbilicus to glow with red light. The area of the stomach is beautifully outlined by the translucency of the tissues to the light of the miniature lamp placed therein for diagnostic purposes. It is only necessary to hold a hand before the source of light or sunlight, for that matter, to be assured of the penetrability of the other rays of light, even through the bones and to the innermost parts of the body. The blood absorbs the chemical frequencies of light, blue, violet and under pressure the ultra-violet as well, according to the law of color absorption. The fact of the fluorescence of the blood indicates a penetration of the frequencies or energy of radiation which the oxygen molecule is capable of absorbing according to the law governing absorption of light. The action upon the peripheral blood supply does not end at the periphery, but must, by its very nature, go on and to the innermost depths, the degree and constancy of effect depending upon the character, length and frequency of exposures to light energies. It seems to the author that there can be no question but that the red rays which penetrate so deeply and which exist in such abundance in an incandescent bath are of value. Just what their function may be is perhaps not so clear as with the chemical frequencies, but function in the very course of nature they must have.

It must not be understood that red frequencies are synonymous with thermal frequencies. The thermal activities must be regarded as invisible heat in contradistinction to such visible heat as characterizes the red frequencies.

The Influence of Incandescent Light Energy upon the Skin.—There is produced by the action of these baths an intense reddening, i.e., hyperæmia of the skin. This indicates a dilatation of the superficial blood vessels. This is a simple hyperæmia, unlike that produced by the chemically active energy of solar light and the electric arc; and unless there has been an intense heat effect, scorching of the skin, it disappears very quickly, as do all hyperæmias brought about by radiant heat, leaving no traces of erythema or of pigmentation. The scorching effect alluded to should never be permitted. Kellogg found from frequent repetition of these baths that the skin did become pigmented or brownish in color, as from exposure to the sun's rays. It is quite possible that frequent repetition, prolonged application and great light intensity may produce pigmentation, for under those conditions there is after all a considerable chemical light intensity operative.

The Influence of Incandescent Light Energy upon Sudation.—This is one of the most marked phenomena from this mode of treatment, and to the profound action upon the sweat glands much of the good derived from its use must be attributed. It is produced more quickly than by any other known procedure and generally appears within from 3 to 5 minutes after entering the bath and quite regardless of the temperature of the bath. Winternitz observed it at 86°F., 30°C. Much longer time is required in the hot air or Turkish bath. This action is unquestionably due to (1) a stimulation of the peripheral nerve endings and (2) to raising the temperature of the patient's body by the action of the radiant heat. As a chemical light bath (the electric arc, where the temperature of the cabinet is but little elevated) stimulates the activity of the sweat glands, the inference is drawn that the action is due in part to a stimulation of the peripheral

nerve endings which follows upon the action of the chemically active energy of an incandescent light bath. Vigorous perspiration may be induced in a small area of the body by the action of the incandescent light energy, indicating that the effect is due rather to the radiant energy of these light sources, than to the hot air of the enclosing cabinet. The parts exposed most directly to the light are first affected.

It was observed by Kellogg that the amount of sweat excreted in the incandescent bath was twice as much for the same time as in the Turkish bath, while the average temperature in the former was 81° F. and in the latter was 140° to 148° F. He also noted that with 50 lamps in operation, the perspiration began in 6 to 10 minutes at a temperature of 95° F. If the temperature of the cabinet is raised to 140° to 158 F°. sweat to the amount of a litre may be excreted in a quarter to a half an hour.

Kattenbracker found 0.26 per cent. of sulphur in the sweat of a glass blower, while the very interesting fact is noted by Below and Aufrecht that traces of mercury were found in the perspiration of persons who had been treated by mercurial inunctions years before.<sup>1</sup>

Crothers<sup>2</sup> notes the marked action upon the secretory centres and that the elimination of fluid is rapid and intense. He finds that patients suffering from toxæmia are profoundly affected by the action of the light baths. In neurotic patients on the other hand the stimulation may not be noticed for some time. This would indicate a diminished power of response of peripheral nerve endings in the latter condition.

Under the influence of electric light a higher temperature from stove heat can be borne with impunity by plants than without it. This was proven by Siemens in his experiments upon plants.

It is the consensus of opinion that the temperature of

---

<sup>1</sup>Quoted by Freund.

<sup>2</sup>New York and Phila. Medical Journal, July 23, 1904. The Radiant Heat Baths.

an incandescent bath and its accompanying effect upon the sweat glands is better borne than a hot air bath. It is much more life-giving, less depressing in its action, an effect which can only be accounted for by the presence of the higher and shorter frequencies. It is not necessary in an incandescent bath to have as high a temperature for the production of transpiration as in hot air or vapor bath because of the action of the other frequencies upon the skin. This action is produced by all the frequencies, including the red, as they all possess more or less chemical power. Therefore, transpirations occur at comparatively low external temperature.

The Influence of Incandescent Light Energy upon the Heart, Pulse and Tonicity of the Arteries and Blood-Count. The statement is constantly made that incandescent light baths do not influence the heart's action. Experimental observation contradicts this statement. In general it may be said that it does not affect it unfavorably as does hot air and vapor baths. M. Roth<sup>1</sup> observed that a pulse which before the light bath had been steady at 72 beats increased rapidly after 10 minutes in the cabinet to 84 beats. After 15 minutes, it gave 104 beats and after 20 minutes 132 beats. At first it remained fairly steady and later on it grew galloping and irregular. The same effect was observed by Stasser<sup>2</sup> and Strebel.<sup>3</sup>

Kellogg found that under its influence the pulse is first quickened and then slowed. Freund observes that it must be conceded that with a temperature in the light cabinet at 122°F. the pulse is quicker each minute by about 15 to 20 beats. Crothers<sup>4</sup> notes that the tension of the arteries invariably fell from the action of these baths. Contrasting it with the hot air bath, he found that the tension did not always change from the action of the latter, unless the time

---

<sup>1</sup>Med. Wochenschr., 1899, No. 19.

<sup>2</sup>Encyclop. Jahrb. 1900.

<sup>3</sup>Quoted by Freund.

<sup>4</sup>Radiant Heat Bath, N. Y. Med. and Phila. Med. Journ., July 23, 1904.

of using it was prolonged. The changes in the pulse he found more marked in the hot air than in the radiant heat bath, usually rising while in the former and falling in the latter. In measurements of the pulse, temperature and tonicity of the arteries the radiant heat bath showed great superiority.

There is then no question of their influence upon the heart pulse and arterial tone, and while the pulse is elevated by the profound and primary action upon the peripheral circulation, still the acceleration of the heart's action is within limits of safety. This is so true that with the precautionary measures insisted upon these baths may be used safely even in grave cardiac disorders. The changes which take place in the pulse are as a rule not so marked in succeeding baths. One of the immediate results of the use of these baths is an increased blood pressure. In most cases, however, this subsides after copious perspiration from a stay of from 20 to 25 minutes in the bath. Sometimes congestion, with bleeding at the nose, has been observed as a result of this increased blood pressure. This is not general. Kellogg found the blood count of the red cells especially markedly increased, 10 to 20 per cent., by the incandescent light bath when followed by the usual cold bath. The increase appears within half an hour.

The Influence of Incandescent Light Energy upon Respiration.—Respiration is very markedly affected by the baths. Kellogg notes that it is free and unembarrassed although somewhat quickened. It becomes twice as rapid after a short stay, 15 minutes, in the light cabinet and is at the same time more shallow and superficial.

Following these baths, the respiration becomes uniformly regular and normal. Kellogg<sup>1</sup> noted a decided increase in the elimination of carbon dioxid, evidencing the active oxidation and tissue changes set up by their action. In his observations of 1894 he noted that the average percentage of carbon dioxid eliminated during a 30-minute incandescent

---

<sup>1</sup>Physiologic Therapeutics, Cohen.



light bath was 5.13 per cent. in a patient who previous to the bath was eliminating 3.60 per cent. an increase of 44 per cent. From a 5-minute exposure the increase was 4.10 per cent. and for a 20-minute exposure 4.20 per cent. In a Russian bath the same subject eliminated an average of 3.96 per cent., an increase of 10 per cent., while in a Turkish bath of 30 minutes' duration the average elimination was 4.11 per cent., an increase of 11 per cent.

Action upon the Urinary Secretion.—In this connection it may be noted that Roth and Kellogg both studied the action upon the urinary secretion. The latter found a diminution in the amount of urea, of the total chlorids and total solids. From Roth's investigation upon the urine and perspiration, these baths do not seem to have any especial marked influence on organic decay in the body.

The Influence of Incandescent Energy upon Body Temperature.—It was observed by Kellogg that there was quite a rapid rise in body temperature from the action of incandescent light baths. In from 10 to 15 minutes he noted an elevation of from  $4^{\circ}$  to  $5^{\circ}$  above the normal. Freund places it about  $2^{\circ}$ F. This is noted by all observers, and the increase in body temperature tends to increase the combustion of fat. The increase of temperature necessarily varies with the duration and intensity of the bath. The difference between the estimates of Kellogg and Freund can be accounted for no doubt by the method of taking the temperature. In Kellogg's observation the extreme rise was noted upon taking the external temperature, the difference in the internal temperature being after  $5\frac{1}{2}$ -minute exposure  $1.6^{\circ}$ F. very near that given by Freund.

The Influence of Incandescent Light Energy upon Bodily Weight.—There is a marked influence of these baths upon body weight, the diminution bearing a relation to the duration and intensity of the bath and its effect upon the perspiration.

This is apt to be counteracted by too free drinking of water. As a result of the profound elimination through

the sweat glands there is usually intense thirst. In most conditions it is better to drink freely under these conditions, and sometimes during the bath. In cases of obesity it is necessary to control the amount of fluid ingested, because it defeats the object to be attained. This should only be done within physiological limits, however.

The Influence of Incandescent Light Energy upon Bacteria.—This form of light energy cannot be regarded as bactericidal, as the bactericidal rays are placed in the middle third of the ultra-violet region. The action of light energy in bacterial diseases does not depend upon an actual destruction of the micro-organism (an impossibility in living tissue no matter what the source of light energy), but upon its action in producing a hyperæmia of the part treated. There is secured by the stimulus imparted increased oxygenation of the blood, and nutritive changes are established which increase the physiologic resistance.

A favorable action of light has been noted by various observers on infected animals, and in this connection Kondratiew, DeRenzi, Kutschuk, and Aufrecht<sup>1</sup> may be mentioned. There is, however, no specific action on the part of the energy of incandescent light. This has been fully established by the mass of evidence as to the action of light energy upon bacteria.

It was observed by Drigalsky<sup>2</sup> that mice inoculated with splenic fever or other bacteria died more quickly in the incandescent light bath than control animals even though they were kept only a short time in the bath. His explanation of this untoward effect is the rational one, viz., that the resisting power of these animals was reduced by the copious perspiration induced by the thermally active energy.

In this connection he wisely calls attention to the danger to many feeble patients, such as the tuberculous, from its use. The author regards the use of the incandescent light bath as absolutely contra-indicated, and never under

---

<sup>1</sup>Quoted by Boeder.

<sup>2</sup>Quoted by Freund.

any circumstances uses or recommends its use in this class of cases. As shown in considering the electric arc bath, the indication in these cases is for the intense chemically active light energy of the sun and the electric arc.

As the bactericidal energy is the same which excites tissue reaction it follows that incandescent light energy, useful as it is in a very considerable range of disease, is practically of but little value in the treatment of any condition requiring intense chemical activity, as in lupus. It best meets on the other hand all conditions where, in addition to a slight chemical effect, there is desired the longer and slower frequencies of the lower end of the spectrum, active thermally. There is, therefore, no question of using it in chronic skin lesions where the short and high frequencies of the blue violet and ultra-violet are so useful. It has a field of usefulness, however, in more recent pathological skin conditions, and especially where thermal energy is indicated as well. It is also of value in minor surgical conditions, as shown in Chapter XIV.

Sensitization.—There is a possibility that by rendering the tissues sensitive by suitable media, that the energy of incandescent light can be rendered more effectual. For this purpose solar energy or that of the electric arc are to be preferred.

The Mode of Action of Incandescent Light Energy.—The physiologic effects of incandescent light baths are due (1) to radiant heat, (2) to chemical energy. This chemical energy, so far as the blue-violet is concerned, is small, ultra-violet none, but it must be remembered that the different frequencies of the spectrum are thermal, luminous or chemical in relation to the substances or structures upon which they fall. It is not known that the longer and slower frequencies below the blue have a chemical action in relation to living tissues, nor again is it known that they have no such action. It is known that they penetrate, and that there is absorption above the red. Absorption does not take place without work being done. The exact nature of that

work is conjectural. On the other hand, in an incandescent bath the blue-violet are to be reckoned with, their chemical intensity for a single unit of light is small, but for 50 to 100 such units it is considerably magnified. Therefore the physiologic effects are to be ascribed to a chemical as well as a thermal energy. The interposition of the body tissues suffices to transform this twofold energy into thermal and chemical energy. The skin is a poor conductor of heat, but transmits radiant energy readily. The heat enters the body as a radiant force, and in this way the heat is carried to the tissues. It is not confined to the surface, as is the case with conducted heat from water vapor or Russian or Turkish baths.

Moeller showed that in radiant energy baths the heat rays readily penetrate even bones. The penetrating light rays below the blue, i.e., the red, yellow and green, considered in relation to molecular activity would seem, by reason of their length frequency and amplitude of oscillation, incapable of exciting chemical action. They doubtless undergo transformation into heat in the deeper structures. This action may readily influence excessive perspiration and excessive drainage of the deeper tissues. It is in turn followed by marked sedation, which can readily be accounted for by the sudden and intense drainage through the skin of the accumulated products of the disturbed chemico-vital action of the system.

The Action of Incandescent Light Energy in Health.—The action of these baths was studied by E. Rosen<sup>1</sup> upon healthy men. Following a series of 12 of these radiant heat baths, a marked improvement of appetite and sleep was noted. There was also a gain in weight. These favorable changes seemed to be lasting. There was now a numerical increase, now a diminution of the cells according to Rosen.

Therapeutic Indications for an Expenditure of Incandescent Light Energy.—Incandescent light baths have been

---

<sup>1</sup>Rusky Vrach, March, 1903.

found useful in conditions of (1) lowered nutrition, the acid dyscrasias, rachitis, osteomalacea, (2) in the lipogenous dyscrasias, obesity, biliary lithiasis, gravel, diabetes, arthritic manifestations of gout and rheumatism, (3) in alterations of the blood state, anæmia, chlorosis, lymphostasis and syphilis, (4) in nervous conditions, tabes, neuralgias, hysteria, psychoses, (5) in respiratory and circulatory conditions, bronchitis, bronchial asthma, cardiac hypertrophy, (6) in diseases of the kidneys, nephritis, (7) in surgical conditions, chronic tubercular ulcers, inflammatory diseases of bones, chronic leg ulcers, paralysis and trophic disorders, (8) in toxæmias, alcohol, drug and metallic poisoning; (9) as a hygienic measure. In some of these conditions they form the remedy *par excellence*, in others an exhibition of a light energy more profoundly chemical in its action is indicated, i.e., solar light or electric arc light energy. The indication for the one or the other is pointed out as far as is possible, but there only need to be kept always in mind the nature of the energy and its action, in connection with the nature of the condition, in order to choose intelligently the one or the other. Incandescent light energy may take the place of the other two to a certain degree if the individual equipment contains but the one instalment.

The Therapeutic Effects of Incandescent Light Energy. —(1) There is established by the action of these baths a profound action on the vaso-dilators of the arteries. By the stimulation imparted to them the blood is permitted to flow more rapidly to the surface. In this way the heart is relieved of its burden, and, at the same time, the constriction to the arterial circulation and the capillaries is also lessened. From this action there ensues lowered tension of the blood stream with an increase in its volume and uniformity. A marked effect upon sensory centres is noted, as is evidenced by a diminution of nerve irritation and debility.

(2) There is established a profound revulsive effect by the dilatation of the cutaneous vessels. For the time being

the blood is fixed in the skin, the "peripheral heart." In this way passive venous congestions are connected with active arterial hyperæmia.

(3) Profound action upon the sweat glands with corresponding elimination actively.

(4) Increased oxidation.

There results from these effects a return to normal skin activity, normal circulation and oxidizing power upon the part of the organism. The general tone is increased and with it physiologic resistance.

Preparation of Cabinet and Patient.—The first depends upon whether it is desired to secure the sudden effect of powerful light action. This would be indicated in robust persons and for such the cabinet should be heated beforehand. The sudden impact, as it were, of this radiant heat at high temperature imparts a greater stimulus, just as a powerful static spark does. In weaker and more fragile patients the air of the cabinet must be heated gradually after the patient is placed therein. The temperature may be gradually increased by switching in additional lamps or adding to the ampèrage by means of the controlling resistance.

The patient is placed naked in the vertical or horizontal cabinets on a stool or slab of glass. A towel may be placed about the neck to prevent the passage of the heated air or light from the enclosing cabinet. A cold bandage, ice, or coil of cool water is applied to the head.

The condition of the pulse must be carefully observed and the admission of fresh air to the patient cared for.

Duration of Treatment.—These baths should be used for varying periods of time according to the effect desired. When the object to be attained is that of sudation or transpiration, the longer exposures and the use of all the lamps within the cabinet are necessary. Where a tonic effect only is desired, however, then a very short exposure, and a fewer number of lamps, i.e., diminished energy of radiation. For the first purpose from 15 minutes to 30 or in conditions call-

ing for profound action even longer. For a simple tonic effect from 3 to 5 minutes suffices.

Frequency of Treatment.—Here, as with other measures, the nature of the case must influence at least the frequency of the treatment. In some conditions and for a limited time, daily baths may be given. Where profound eliminative effects are desired this may be done and also for the promotion of absorption of inflammatory exudates. But, as a rule, the need for daily exposures will be met by the first 3 to 5 treatments. After that from 3 times, twice to once a week. Too frequent an expenditure of energy is as harmful as too prolonged an expenditure. The needs of each individual patient must be conserved by the skill, experience and care of each individual operator.

After Treatment.—This should assume the form of a bath, douche or wet pack.

It may be further supplemented by mechanical measures, as massage, vibration or by the use of the electric current. Each case will present its own indications, the rationale of it all being to use such a measure as will best assist in securing a return to physiologic circulatory conditions without overtaxing the patient.

Feeble patients should always rest for shorter or longer periods of time. The author believes that the best good of the patient is attained by a period of rest immediately after the expenditure of any form of energy. This applies to those who are frankly ill, not to robust patients who use this form of light energy as a hygienic measure. As a hygienic measure incandescent light baths are of value. This fact is taken into account occasionally in the fitting up of men's clubs. Such a light bath from once to twice and three times weekly for 5 to 10 minutes, followed by a bath, or a short plunge at from 65° to 75°F., or a vigorous douche at a temperature of from 50° to 60°F. will amply repay the individual. In the conservation of the physical forces and the prevention of disease there is to be found after all the physician's highest work.

Incandescent Light Energy in Obesity.—In the use of these baths in obesity there must only be considered (1) the pathological nature of the condition, and (2) the physiological action of light energy from this source, to appreciate at once its very great value in this class of cases. Obesity is fundamentally a condition of suboxidation and imperfect eliminative processes. Moreover, it is apt to be associated with grave dietetic and hygienic errors. There is not only the powerful action of incandescent light energy, when thus concentrated upon the sweat glands, but there is as well a profound and penetrating action upon the deeper structures of the skin, and of the tissues of the body as well. As a result nutritive as well as eliminative changes are established. A considerable part of the light energy thus absorbed is converted into heat, which serves to stimulate to an unusual degree the consumption of fat, as is evidenced by increased carbon dioxide elimination.

According to Kellogg, there is more than 40 per cent. increase in tissue consumption. This in view of the fact that at least three-fourths of the energy of the body is consumed in heat production becomes a matter of the highest importance.

By an expenditure of this light energy over considerable periods of time, an hour or more, there would result a considerable loss of fat.

Conrad Klar<sup>1</sup> has shown that the heat elimination may be increased to more than ten times the normal amount and that it may be continued not only for a few moments but over considerable periods of time, when the temperature of the air surrounding the patient is below the temperature of the body, provided that the blood vessels are maintained in a state of active dilatation, as is possible with an incandescent light bath but in no other heating procedure.

Winternitz has observed after one such bath followed by a douche, that the weight has diminished from 700 to 800

---

<sup>1</sup>Physiologic Therapeutics, Cohen.



grams. Eiffer, Gautier and Imbert de le Touche have obtained equally satisfactory results without enfeebling the patient or obliging him to submit to debilitating dietetics. The bath need not in such cases be of high temperature,  $98.6^{\circ}\text{F.}$ ,  $37^{\circ}\text{C.}$  Winternitz has observed the appearance of perspiration at a temperature not above  $86^{\circ}\text{F.}$  or  $30^{\circ}\text{C.}$  While care should be taken in patients where cardiac function is enfeebled, still even with them these baths are very well borne. There is usually an acceleration of the pulse but it remains full and regular.

Chasserant<sup>1</sup> records a case where it was a question of a mixed form of obesity, in which by an unimportant restriction in the régime, combined with incandescent light baths, there was obtained at the end of about 6 weeks a diminution in weight of 25 pounds. In another case, where it was a question of the constitutional form, the patient although always eating little had continued to increase in weight. She had tried to limit the amount of food to the strictest minimum without any result. Incandescent light energy was prescribed in the form of the cabinet bath to be followed by massage, without modifying her normal régime. At the end of 40 days, during which time she had taken 38 baths, there was a diminution of 30 pounds in weight. For 6 weeks treatment was discontinued, during which time she increased 5 pounds in weight. Further treatment for 2 weeks resulted in a loss of 10 pounds. While it is best to combine the expenditure of some other form of energy, hydiatic measures, electricity, massage or physical exercise with the expenditure of incandescent light energy in these cases, still there is no question but that in the case recorded the diminution in the weight should be attributed to the action of the incandescent light energy, for experience has taught us the futility of massage to reduce the weight in the same class of cases.

---

<sup>1</sup>Treatment of Obesity by Baths of Electric Light. *Rev. de Therapeut.* March, 1902. *Rev. Internationale d'Électrothérapie et Radiothérapie.*

The diminution of weight in these cases is more or less according to the amount of perspiration. This is usually accompanied by extreme thirst (not alone in obesity, but in all classes of cases where prolonged exposure to intense incandescent light energy is employed), which if satisfied may counteract to a certain extent the good effect. The dietetic régime should therefore receive attention.

According to Strasser<sup>1</sup> this form of light energy is especially suited to the hydræmic forms of obesity, particularly the anæmic, pasty-looking type found in young people. For the plethoric type of corpulent patients he prefers packs.

The temperature of these baths may vary from the minimum to a maximum, which differs with different operators. Kellogg<sup>2</sup> has placed it at from 150°F. to the highest temperature tolerable. It is reported that some French observers have employed a thermometer the bulb of which is covered with lampblack, a great absorber of heat, which is also fully exposed to the action of the thermally active energy by being placed upon the patient's body. Therefore their measurements are not to be relied upon.

According to Strelbel, the temperature should never exceed 113°F. for this class of cases. The author regards this a safer temperature, but each case must after all govern itself. There are some obese patients who will withstand a very considerable expenditure of light and other forms of energy; while on the other hand there are those whose endurance in this regard is limited.

The Influence of Incandescent Light Energy upon Gout and Rheumatism.—Perhaps incandescent light energy does not lend itself to the securing of better results in any other class of cases than these. There is obtained from these baths in both gout and rheumatism rapid relief from pain and other symptoms. The exposures may be either general or local or general supplemented by local where especial joints are implicated. A certain discrimination is required,

---

<sup>1</sup>Blätter f. klin. Hydrother. 1900, Nos. 4, 5, p. 94.

<sup>2</sup>Kellogg: System of Physiologic Therapeutics, Cohen.

however, in their use. In gouty patients it is not always well to call too severely upon the fluids of the body, as a thorough transfusion of the tissues with fluid is desirable. Under these circumstances and also in rheumatic affections of the joints, a light energy less active thermally and more active chemically is indicated. To this end either the energy of solar light or of the electric arc should be used. In muscular rheumatism, lumbago and torticollis, incandescent light energy is of very great value. By its use there is increased elimination of toxic material and the promotion of oxidative processes. In these cases the bath should be given every other day, at first to the point of producing vigorous perspiration and an elevation of the body temperature 2 or 3 degrees. Daily exposures may be indicated in the beginning, but should not be continued so often for too long a time. They should be given from daily to three times, twice or once a week as the case progresses. The general bath should be given from 3 to 5 minutes, or longer, according to the indications in the individual case.

The after treatment in this class of cases should preferably be a cold plunge  $65^{\circ}$  to  $75^{\circ}$ F. If this is not available a very excellent substitute may be found in a cool bath or cold towel rub. Again the needs of the individual must be met as they rise. Routine treatment is never successful.

An expenditure of electrical energy will materially aid the progress of this class of cases and may be made by a general application of the magneto-induced sinusoidal, static or high frequency. The two latter are very efficacious and the preference is apt to be given to them, as the clothing offers no obstacle to their use.

The Influence of Incandescent Light Energy in Rheumatoid Arthritis.—Friedlander<sup>1</sup> found that the electric light (cabinet baths) gave better results than Turkish or Russian (steam or hot air chamber) baths. In the treatment of this disease, the two last named are objectionable because

---

<sup>1</sup>Handbuch Der Physikalischen Therapie, Teil II., Bassel I., Leipzig, 1902.

(1) they with difficulty admit of precise dosage. (2) They have here a weakening effect, and they make a serious demand on the circulatory system.

There is no question but in an expenditure of radiant energy much better results would follow in rheumatoid arthritis than from any other expenditure of thermal energy. Excellent results are secured in these cases from the use of static electricity administered convectively, disruptively or conductively, according to the needs of the individual case. The author believes that the well-known helpful action of the electrical treatment would be enhanced by a preliminary exposure to incandescent light energy. Great care should be taken not to prolong the light bath unduly nor to permit too intense a temperature. The minimum exposure and minimum temperature at which perspiration is induced should be the rule until the patient's toleration is fully established. This the author follows by the electrical treatment as above, preferably to any other physical measure, save the necessary rubbing down (1) with alcohol or (2) with the cold mitten, according to the indications and only for a period of time necessary to thoroughly dry the skin.

The influence of Incandescent Light Energy upon Diabetes.—In this class of patients the author yields the preference to the electric arc because of its deeper and more intensely chemical action. Still there is considerable evidence to show that incandescent light baths are useful and when judiciously used they may take the place of the electric arc, where the equipment affords but the one, just as the exhibition of one drug may take the place of another in the absence of the first. An exception may be made preferably in favor of the incandescent light bath in fat diabetics. They are especially likely to be favorably affected by these baths. Under the powerful stimulation of the light energy, thermal and chemical, the inactive skin becomes active and free perspiration is established. The well-known oxidating action of the light results in an increased oxidation and a lessened excretion of sugar. An increase of the alkalinity of the blood is but a

part of this process, but one that is of value in the correction of this perversion of nutritive action. There may be expected in the average case a relief of symptoms. The after-treatment, hydriatic, massage, or electrical, must depend upon the individual case. Prolonged exposure at a considerable temperature should be followed preferably in all cases by cold douching.

The Influence of Incandescent Light Energy in Anæmia and Chlorosis.—Excellent results have been obtained in these conditions by the use of the incandescent light baths.

Save in fat anæmics and chlorotic patients the energy of the electric arc or of the sun is to be preferred because of the greater quantity of penetrable chemical frequencies and their absorption by the blood. In fat anæmic patients the radiant heat bath, by reason of its intense thermal activity, is to be preferred. This class of anæmic cases do not do well until they are rid of their superfluous flesh. Afterwards the progress of such cases should be furthered by the use of the sun or electric arc baths. An increase of hæmoglobin and erythrocytes was observed in anæmic persons by Winternitz after each bath. The more profound effect of the chemical frequencies in producing lasting hyperæmia and pigmentation with a removal of the blood corpuscles from their ordinary course, stimulating the system to replace the blood corpuscle, and the more vigorous carrying on of the metabolic processes renders solar light and electric arc light better in anæmia and chlorosis, and, for that matter, in all conditions involving an alteration of the blood state.

It was noted by Kellogg that the increase in the blood count, red cells especially, in anæmics was permanent where the bath was used daily. The temperature of the bath should not exceed 95° to 104°F. (35° to 40°C.), and the time of exposure should be short, stopping when transpiration begins.

After-Treatment.—A tempered douche, either jet or rain, or a short tepid bath should follow.

Contra-Indications.—There are practically none.

The diaphoresis and the consequent thirst secures the ingestion of considerable quantities of water, which favors normal osmotic processes and facilitates the removal of waste material or toxic agents, which serve to prevent normal oxidation and tissue change.

The Influence of Incandescent Light Energy in Nervous Diseases.—Incandescent baths are reported to have been found useful in a considerable range of functional nerve disorders, but in the author's opinion they are not comparable in this class of cases to the electric arc bath or sun-bath. An exception may be made in favor of the symptomatic neurasthenias where the disturbed nerve function is due to toxæmia or auto-intoxication. Certain hysterias and epilepsies more or less dependent upon a toxic condition should be benefited by their use. They have been widely recommended in neuralgias of all sorts, and for the physician having but the one equipment, can be used in all these functional nerve disturbances, but the preference should be given (1) to the solar energy, (2) to the energy of the electric arc. There is a considerable variety of opinion among different writers as to the value of incandescent light energy in functional diseases of the nerves. By some their good effects are lauded, their soothing effect on general irritability, sleeplessness, ringing in the ears, oppression and palpitation of the heart, as noted by Colombo, for example. The difference in opinion doubtless has its explanation in indiscriminative diagnosis. Good results will follow the use of these baths in functional nerve disturbances, which are not essential but symptomatic and due to a toxæmia. Colombo reported excellent results in all vague neuralgias due to the so-called "uric acid diathesis." An essential neurasthenia is not a suitable condition for these baths, but, as has been stated, does well under the influence of the electric arc. Neuralgia and migraine, Kellogg, Strebel and Freund relieved by incandescent light baths.

When used in motor troubles and muscular atrophy, re-education in movement, mechanico-therapeutic gymnastics and electricity should be used in connection with them.

It was observed by Foveau de Courmelles<sup>1</sup> in 1893 that the total white light from incandescent lamps exercised an anæsthetic and calming effect when directed upon the nerve centres, spinal cord, and he used it combined with the static douche in the treatment of neurasthenia. Later the same observer found the incandescent light bath, in which the patient's body was placed, with the head only emerging, an excellent tonic to the spinal cord, and of service in the treatment of myelitis.

In the author's experience a neurasthenic patient, whose condition was complicated by severe spinal congestion, and who suffered not only from insomnia, but from intense pain at the roots of the cervical nerves, had relief from the application of an incandescent light bulb directly over the cervical cord. Sleep without hypnotics was only obtained in this way, the patient sometimes leaving the light burning all night, because of falling asleep under its influence.

The Influence of Incandescent Light Energy in Respiratory Diseases.—Reider<sup>2</sup> states that incandescent light baths afford good results in chronic bronchitis, and in bronchial asthma.

In so far as these conditions are dependent upon the so-called lithæmic diathesis they should be benefited by them. But for all diseases of the respiratory system as such, the electric arc or solar light is preferred.

Cardiac Hypertrophy and Cardiac Dropsy.—The same observer obtained good results in these conditions from the use of incandescent light baths. Kellogg states that in his experience the bath must be used with a considerable degree of caution in this class of cases. The temperature should be

---

<sup>1</sup>Report of Light in Nervous Therapeutics, by Foveau de Courmelles, *Revue Internationale d'Électrothérapie et de Radiothérapie*, Jan., 1904.

<sup>2</sup>Quoted by Kellogg, *System of Physiologic Therapeutics*, Cohen.

low at first, increased very gradually, and high temperatures always avoided. The heart must be guarded by ice or a cold precordial coil placed in position before the light is turned on. The application should be brief, barely sufficient to induce gentle perspiration. Cold mitten friction should be applied immediately afterwards, and care taken to prevent chilling by exposure after the bath. The cutaneous activity from the action of the radiant heat, with the precautionary measures suggested, greatly relieves the overburdened heart by diminishing the distension of the right ventricle, by lessening the resistance in the peripheral vessels, and by setting at work the "skin-heart," which is often most inactive in those conditions.<sup>1</sup>

In grave cardiac conditions, sun baths or the electric arc bath are to be used preferably, as, for example, in valvular heart disease. The same is true of congestions of the *venæ portæ*, *angina pectoris*, and in difficulties of breathing. They are not only more effective, but do not possess the same element of danger for this class of cases as incandescent light energy.

The Untoward Influence of Incandescent Light Energy upon the Heart.—Krebs<sup>2</sup> has observed that it would be an error to believe that incandescent light energy in the form of baths has no effect upon the heart. In almost all cases studied by him he has observed that the profuse secretion of perspiration produces accentuation of the pulse and diminution of the blood pressure, but the increase of the frequency of the pulse in equal conditions of rest was less great than in the bath of superheated air. This is corroborated by Hedley. Although the bath of incandescent light energy is more grateful and better borne by the patient whose heart is feeble, yet Krebs believes it not to be without danger for patients having organic lesions.

---

<sup>1</sup>Physiologic Therapeutics, Kellogg.

<sup>2</sup>Diaphoresis by Electric Light Baths and Superheated Air. *Zeitschrift für Diätetische und Physikalische Therapie*, Bd. VI., H. 21, No. 2.



The Influence of Incandescent Light Energy upon Arterio-Sclerosis.—Incandescent light baths, while of much value in arterio-sclerosis, are unsuitable in extreme cases. They should be administered with great care, the heart's action and condition of the circulation carefully watched. If there is not prompt reaction upon the part of the skin, as evidenced by perspiration from the earlier baths, they are contraindicated. The temperature of the bath and the length of the exposure should be governed by the individual case, and also the after treatment. In the author's judgment the minimum temperature and length of exposure are indicated. The condition of the blood vessels must not be lost sight of, their rigidity and inability to accommodate themselves to too intense or too prolonged thermally active energy. After treatment in this condition would better assume the form of an alcohol rub or cold mitten friction. This in turn may be followed to the advantage of the patient by the convective discharge from an excited influence machine.

The Influence of Incandescent Light Energy in Nephritis.—Because of the fact that the incandescent light bath produces abundant diaphoresis without materially augmenting the work of the heart it is of service in all albuminurias. It is not that they affect the cause of the trouble but that they relieve the symptoms which interfere so much with the comfort of the patient. There is, however, prompt relief afforded to the congested and inflamed viscera by the diversion of from one-half to two-thirds of the blood in the body to the skin. These baths, according to Kellogg, may be prolonged for many hours if necessary (the condition of the patient must govern both the length, frequency and temperature), but care must be taken to refresh the patient at intervals by a very energetic cold rub with a friction mitten, by an ice-bag over the heart and by cold compresses to the head. Great care must be taken to avoid chilling. A slight exposure of the body to the influence of evaporation from a moist surface might be sufficient to cause contraction of the blood vessels and counteract the good effects of the bath.

Immediately after the bath, the patient should be wrapped in flannels and preferably placed in bed.

Frequency and Duration of Treatment.—This latter is placed by Kellogg at from 4 to 6 hours and to be repeated in from 24 to 36 hours. Cases of this sort must be guarded against too great an expenditure of energy.

By reason of the fact that incandescent light baths produce but a temporary hyperæmia of the skin and therefore only temporary depletion of the internal organs, they are of less value in diseases of the viscera, where circulatory drainage is necessary, than the more penetrable chemically active energy of the electric arc and of sunlight. Still in their general ability to produce safely profuse diaphoresis the incandescent baths are desirable. When there has been secured copious sweating better results should follow the use of the electric arc bath. The indications for beginning the latter would be the same as for the suspension of other agents used to promote diaphoresis.

By the use of both incandescent and electric arc baths different observers have noted a diminution in the amount of albumen.

Contra-Indications—Uremic Crises.—In conditions of cardiac weakness great care must be taken and the condition of the heart's action carefully watched during the progress of the bath.

The Influence of Incandescent Light Energy in the Toxæmias.—Whether the condition is that of an auto-intoxication, metallic poison, alcoholism or drug habit there is to be found in incandescent light baths the best possible eliminative agent. There is secured by reason of the profound sudation the ingestion of water in considerable amounts which acts as an internal tissue lavage and by its absorption promotes normal osmotic as well as chemical action. The drainage of the deeper tissues facilitates the throwing off the accumulated residue of toxic material. At the same time the tonic action of the light energy with associated hydriatic measures tends to the establishment of a different funda-

mental condition on the part of these patients. There is secured a better foundation in the case of alcoholics and drug habitués upon which to build in using specific drug medication.

The Influence of Light Energy in the Toxæmias and Toxic Neuroses.—Nothing can be more important than the fundamental drainage and washing clean, as it were, the organism of all its accumulated impurities. The action of incandescent light energy in this class of cases is illustrated in several of the cases reported by Dr. T. D. Crothers<sup>1</sup> at the 1903 meeting of the American Electro-Therapeutic Association. Crothers, from a series of a thousand baths in toxic neuroses and in the palsies, found them of the very greatest benefit. He finds that they are to be preferred to hot air and vapor baths, which he formerly used for the same class of cases. In the toxic neuroses, under which he mentions the various influenzas and digestive troubles indicated by irritation, depression, headache, irregular heart action and other forms of obscure nerve manifestations, he found the incandescent light baths of the greatest benefit. When associated with appropriate hydiatic measures he finds them of greatest benefit in what he terms the general palsies under which he mentions the neurasthenias, cerebrastrhenias, the multiple palsies and defects of the motor and sensory centres, where nerve vigor, force and energy are disturbed and depressed below the normal, also in many of the conditions following a deranged cerebral circulation with defective nutrition, the vaso-motor facial palsies, so common among drinkers, were also favorably influenced, from a modification of the condition to complete recovery. In these anomalous cases, he used in conjunction with the radiant energy of baths the convective discharge from a static machine, mechanical massage, vibration, hydiatic measures, according to the case. Saline waters were administered before the bath when indicated. These cases reported by Crothers are mentioned in

---

<sup>1</sup>N. Y. and Phila. Med. Journal, July 23, 1904.

this connection rather than under the head of nerve disorders, for the reason that they are the neuroses of toxæmia and as such lend themselves admirably to incandescent light energy. Nerve disturbances not so induced, neurasthenia essentialis and locomotor ataxia, for example, need the chemically active energy of the sun and electric arc.

Case I.—An active business man in middle life suffered from fainting and dizzy sensations following excitement and over-exertion. The heart was hypertrophied and the arterial tension was high, indicating hardening of the arteries. He was given electric light baths daily with hot showers and douches and the static breeze. This treatment was followed by recovery.

Case II.—A business man of alcoholic habits, whose life had been one of great mental strain and worry, came under his care for asthmatic symptoms associated with sudden depressive heart action. A course of Turkish baths had failed to bring relief, and he complained of dizziness with fluttering heart sensations, for which various forms of alcoholic stimulants were given. The alcohol was withdrawn and the patient put on an active saline treatment. The radiant light bath, followed by showers and douches and constant rest in a reclining position, was given. The bath produced intense prolonged sudorific action with a high surface temperature. In some instances this temperature went up 3 or 4 degrees, but quickly dropped under the influence of showers and douches. The pulse rate declined with each bath and the fluttering heart symptoms disappeared. Later the heart centres seemed to be very greatly disturbed, and as in the morning he complained of chills and cold he was taken to the light bath for a few minutes, being taken out before perspiration began. The regular bath was given in the evening, after which he slept quietly. There was evident toxæmia in this case, indicated by the strong acid odors from the perspiration during the first week of treatment. A static breeze was given every day in connection with the bath. He made a good recovery.

Case III.—A lawyer, 35 years of age, had used spirits for relief from insomnia and the fatigue of overwork for many years. He had been under the care of many physicians, and had taken electrical treatment with a variety of drugs, but had gradually grown worse. Spirits and drugs had been taken alternately for years. After preliminary treatment by salines and the withdrawal of spirits the use of radiant light bath was begun. The perspiration was not very intense at first, but the action of the heart was increased. The temperature dropped from one to two degrees. On each succeeding bath the pulse rate was raised from 10 to 15 beats and the temperature lowered. At the end of a week all drugs were dropped and the bath was given daily. The rest after the bath was very refreshing and increased in duration, until finally he could sleep about 8 or 9 hours. The insomnia passed away and the restoration was rapid and complete.

Case IV.—A physician, 50 years of age, who had suffered a severe electric shock 5 years before had from that time drunk spirits steadily to quiet his nervous system and to promote rest at night. He had an intense fear and dread of electricity in every form and had strong delusions that he would be injured by an electrical current in some unknown way. For some time after coming under care he refused to take radiant light baths, using the hot air bath and receiving the shower and massage afterward. Perspiration was induced slowly and but little change in the temperature followed these baths. He finally consented to take a radiant light bath, remaining in only 3 or 4 minutes at first, just long enough to cause slight perspiration. It was found that his skin was over sensitive to the action of light, and intense perspiration broke out in 4 or 5 minutes after admission with a high surface temperature. The shower afterwards reduced his temperature. The heart's action was raised, but fell quickly from the action of showers to normal. A marked sedative effect followed these baths with the disappearance of the electrical delusion and a rapid improvement mentally. A persistent dyspepsia, which had followed him for many

years disappeared and he recovered and is now at work again in his profession.

Case V.—A medical man, neurotic and a gourmand, had been alternately a drug-taker and spirit-user for many years. At times he would abandon them all and live for months in strict abstinence. He was credulous and had great confidence in drugs and used freely many prescriptions, both proprietary and other combinations. He had taken electrical treatment and had been an inmate of 2 sanitariums without receiving much benefit. On admission he was using paraldehyde 4 times a day and was considered a chronic inebriate. All drugs were withdrawn, and he was given the electric light bath twice a day, remaining in the cabinet until perspiration was very profuse, then taken out, showered and put to bed. The temperature was invariably lowered and the pulse was raised by the bath. Later on the first morning bath was confined to 2 or 3 minutes, while the evening bath was continued 10 or 12 minutes. The surface temperature of the body was  $105^{\circ}$  and  $106^{\circ}$ F. after leaving the cabinet, but rapidly went down to normal after the showers. The condition of the arteries improved, and both the bowels and kidneys acted quite freely after the evening bath. Later, the static breeze was given, before the bath and sometimes after. With improved nutrition the nervousness disappeared and restoration followed.

The Influence of Incandescent Light Energy on the Absorption of Exudates.—These baths have been used with good effect upon chronic exudations and effusions. Especially have they been used in France for promoting the absorption of exudates in the cornea of the eye and vitreous opacities. Keratitis parenchymatosa, iridocyclitis, choroiditis and other conditions of a similar pathologic nature are mentioned by Freund. Kellogg states that he has used incandescent light energy with most gratifying success in the absorption of exudates in the pleural and peritoneal cavities, and in and about the joints. From their general and local use combined with appropriate hydropathic measures, absorption of

exudates in and about joints is rapidly stimulated, and the author questions if there is a better means to the end. The treatment of joints need not necessarily be confined to incandescent light energy. On the other hand, the electric arc with a parallel beam converged to a focus on the affected joints in long-standing processes should yield better results. In this way not only the necessary thermal energy is provided, but an intense chemical energy as well of great penetrating power.

Contraindications.—Contraindications are found in organic heart disease, and marked congestive symptoms, in phthisis with night sweats (the author advises the use of the electric arc or of sunlight in all cases of phthisis, and never under any circumstances uses the incandescent light in this class), in hemorrhagic cases, hæmoptysis, hæmatemesis, apoplexy, and in all cases where no perspiration results from the earlier baths.

Other contraindications may be found to exist either in other pathological conditions or in individual cases, the rationale of which will appear from the fundamental principles of the action of incandescent light energy in connection with physiological action, and its relation to the especial pathological manifestation.

## CHAPTER XI.

The Concentrated Visible Chemical Frequencies of the Solar Spectrum. Mechanisms, Methods of Use and Therapeutic Indications. Malignant Pustule, Diphtheritic Croup, Pneumonia, Pulmonary Tuberculosis and Lupus Vulgaris.

### The Concentrated Visible Chemical Frequencies of the Solar Spectrum.

In the visible chemical frequencies of solar light there are to be had in great abundance the very penetrating and valuable blue-violet frequencies. These, when concentrated and used in such a manner as to eliminate in part the intense thermal energy of solar light, can be used in a considerable variety of morbid conditions. In fact, they are useful in every condition to which light is applicable, but not as useful in deep-seated localized skin conditions, lupus vulgaris, for example, as the electric arc light, because of the slight chemical intensity in the ultra-violet region at the earth's surface, as compared with that artificial source of light, and also because with a simple convex lens, not only the light energy but the thermal energy as well is gathered into a focus. In this focus so high a temperature is generated that it is simply impossible to expose living matter to it for any length of time. It is only necessary in this connection to recall one's youthful experiences with the burning glass for the purpose of ignition; or, to still further emphasize the fact of this intense thermal energy, to instance the burning of the vessels of the Romans before Syracuse by Archimedes.

The Use of a Parabolic Mirror to Prevent Undue Heating.—It is noted that as the red or thermal frequencies are less refrangible than the frequencies above the red, they may



be eliminated to a certain extent by means of a parabolic mirror. For this purpose only the reflected rays of the sun, not the direct as per the method of Finsen are used and these refrangible rays are condensed and focussed on the patient in the usual way.

Concentrated sunlight is obtained by using (1) convex lenses, or (2) concave mirrors.

Many years ago the burning glass was used for the purpose of concentrating sunlight upon the affected part. From its use in this manner good results were obtained. In connection with such use there may be mentioned the names of Butler,<sup>1</sup> Thayer, Mehl, Piffard, and a layman mentioned by Otterbein.<sup>2</sup>

Willard<sup>3</sup> states that within his recollection Butler in the sixties, some 40 years since, successfully employed sunlight for the treatment of epithelioma using for the purpose an ordinary biconcave lens.

Piffard<sup>4</sup> is authority for the statement that he employed sunlight, concentrated by means of a glass lens, about 25 years ago, for the treatment of a few cases of lupus. By this means the lesions were simply burned out, as in concentrating the light of the solar spectrum by a glass lens. the thermal frequencies are extremely active. Every one is familiar with the action of concentrated sunlight through a glass lens in the ignition of inflammable material. This action was the same in Piffard's original work, as there is no mention of any filtering arrangement for the exclusion of the thermal activities, as in the case with the hollow lens filled with a solution of sulphate of copper as used by Finsen.

The Sun Lens as Used by Finsen.—The solar condenser, as devised and used by Finsen at his institute in Copenhagen, consists, first, of a hollow plano-convex lens, 25-30 cm. in diameter, with a focal distance of 60 cm. It has a capacity

---

<sup>1</sup>Quoted by Willard, Sunshine vs. X ray, Jour. Am. Med. Ass., July 18, 1903.

<sup>2</sup>Quoted by Finsen.

<sup>3</sup>Ibid.

<sup>4</sup>N. Y. Med. Record, March 7, 1903.

of about 2 liters, and was filled with an ammonical solution of cupric sulphate. The object of the copper solution is to absorb not only the thermal frequencies, but all save those having the same refrangibility as the corresponding color of the spectrum. This lens is mounted on a foot in such a way as to enable the operator to give it a vertical, horizontal, as well as an up-and-down movement at will. All the frequencies then from the edge of the blue to the ultra-violet region, none less than 30 microcentimetres, however, in passing through this lens are condensed, and focussed at a point of about 60 cm. from it. In this way there is provided a greatly condensed luminous sheath of practically pure chemical frequencies other than the ultra-violet.

These frequencies are possessed of a germicidal action, as is shown by the action of sunlight on bacteria and upon polluted streams.

The Purely Bactericidal Frequencies not Present in Condensed Solar Light.—The purely bactericidal region as shown by the experiments of Bernard and Morgan, however, is not present for two reasons: (1) That but few of the short high frequency waves of light, ultra-violet are present in sunlight at the earth's surface, because of their absorption by the atmosphere, and (2) the glass of the condensing lens effectually absorbs such as there are. A lens so filled with cupric solution does not completely eliminate the thermal activities, and it may be necessary, therefore, to have a second lens, which is used as a compressor to dehematize the tissues, also made hollow with two canulæ, one afferent and one efferent, in communication with the cavity. Through this a current of cold water was kept constantly passing. Because of the prolonged exposures necessary with condensed sunlight in the treatment of organized skin conditions, the solution in this second lens also becomes hot.

W. H. Dalphe<sup>1</sup> states that with this second heat filter, he

---

<sup>1</sup>W. H. Dalphe, B.A., M.D.: Light as a Therapeutic Agent, lecture delivered to the students of the class in Pharmacology and Therapeutics, University of Bishop's College, Faculty of Medicine, Montreal, March, 1903.

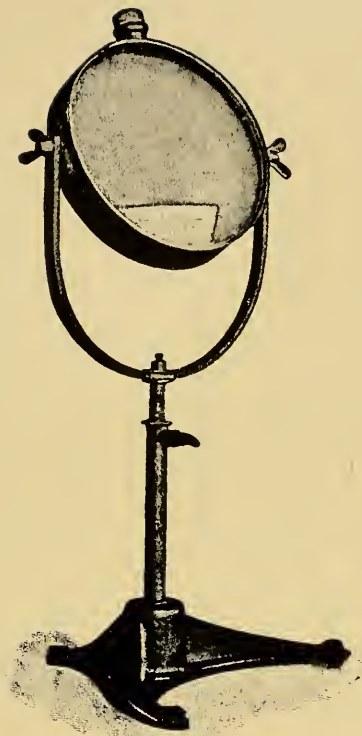

Fig. 15.—Sun Lens.



has been obliged to interrupt his sittings and that through it he could set fire to paper or cotton goods in a very short time.

Methylene blue is sometimes used in the large hollow condensing sun lens as a filter of the longer slower frequencies below the blue. A solid lens, with or without a blue glass filter, may be used, either in connection with a circulating water glass filter, which is independent of the lens, or without it.

Photographic Ray Filter for Concentrating Solar Light.—Kime<sup>1</sup> used a modification of the ray filter employed in photography, with an 18-inch focus. At the focal point it is intensely hot, but he found that in some cases nothing short of this intense heat established reparative processes. This was by reason of the fact that both the source of light (sun) and the means used (glass) absorb the very valuable and more intense chemical frequencies, ultra-violet, so necessary in combination with the blue-violet in establishing tissue reaction and securing the regressive and productive tissue changes essential to the reparative process. In his work he utilized a beam of sunshine one foot in diameter, which fell through the office window upon the sun glass, the hollow chamber of which was filled with a solution of sulphate of copper for the purpose of absorbing the frequencies below the blue.

Not all of the Component Parts of White Light can be used with a Sun Lens.—Once more in this connection it may be reiterated that none of the ultra-violet below 30 micrometres can pass through the glass. A still further influence is exerted by the liquid in the filter, weakening the intensity of such chemical energy as is otherwise obtained from the ultra-violet region of greater wave length as it borders on the blue-violet. The experiments of Bernard and Morgan upon bacteria may be referred to in this connection, as showing that four-fifths of the bactericidal energy is ab-

---

<sup>1</sup>Kime: Light in the Treatment of Lupus and Other Chronic Skin Affections. Journ. Am. Med. Ass., April 11, 1903.

sorbed by passing through 2.5 cm. of water. There is still further absorption by the addition of methyl blue or an ammoniacal sulphate of copper.

Ultra-Violet not Transmitted through Quartz Containing Chamber when Filled with Ammonia-Copper Sulphate Solution.—Under proper conditions of experiment, i.e., with a quartz containing chamber for the ammonia-copper sulphate solution, 5%, through which the beam of light is allowed to pass upon examination by means of a grating spectroscope, it is shown that blue, indigo and violet frequencies pass, but practically no ultra-violet. However, as with the glass containing lens, the ultra-violet are cut off in any event, the blue filtering solution does not interfere with the residual energy of the visible chemical frequencies of the spectrum.

Were it practical to have sun lenses made of quartz, then by filling them with uncolored water there could be obtained a greater proportion of the non-absorbed (i.e., by the atmosphere) of the ultra-violet frequencies than with a blue filtering fluid. But because of the scarcity and expense attendant upon the quartz lenses, this is not practicable. It is clearly shown in these pages, however, that valuable as the ultra-violet frequencies are (1) in bactericidal power and (2) ability to excite tissue reaction, they are not absolutely essential to the obtaining of therapeutic results in skin conditions. Finsen's early work with the sun lens was demonstrative of this fact. If ultra-violet energy be of low intensity, it is absorbed by the surface layers of the skin, but if of higher intensity, a violent inflammation of the skin is produced. See Action of Light Energy Upon Skin, Chapter VII.

This intensity of ultra-violet light energy is such as is obtained from iron electrode arcs, for example the original Bang lamps, or those modelled by it.

The Complex of Chemically Active Light Energy Produces the best Results.—Under the use of the concentrated chemical frequencies of the electric arc it is clearly pointed out that the penetrant blue, indigo and violet frequencies are

factors of great importance where deep-seated processes are to be acted upon, that their presence is more necessary than the ultra-violet, but that, after all, it is the complex of chemically active light energy which is capable of producing the best results.

If the thermal energy is sufficiently eliminated by the filtering arrangements for that purpose, it is not possible to produce so intense an inflammation upon the healthy skin with concentrated sunlight as with the electric arc, by reason of the absence of the ultra-violet.

In the adjustable photographic ray filter used by Kime there is at the focal spot intense heat which produces a strongly irritant action upon which he depends for the excitation of the necessary reaction, i.e., the production of hyperæmia inciting in its turn new vigor, new cell action, and subsequent reparative processes. This action is due to the combined influence of the concentrated thermal and chemical energy.

Concave Mirrors for Concentration of Solar Light.—A greater quantity of light can be concentrated by means of concave mirrors than can be done by lenses. Kime has utilized this fundamental principle in the construction of his sun room at Denver for the treatment of tuberculosis pulmonalis. Strebél also uses metal reflectors one metre, 39.5 inches, in diameter but with a water-cooling arrangement in front of them.

Technique.—The technique with the sun lens is the same so far as preparing the lesion for exposure as with any source of light, viz., freeing the diseased surface from crusts. In addition, in Kime's work the part was washed with water, but no antiseptics were used. This is a matter which varies with the individual operator. The light is moved over the tissues, coagulating the albumin in the tissues, until it is of a smoky white color. The light is used at the focal point for this, and the action desired is secured in a few minutes. This application should always be made by the physician himself, but afterwards for the subsequent

and prolonged application of the light, non-focal, it may be left in the hands of the nurse or office attendant, who continues the application for 10 minutes longer. A wet dressing is then applied, to be removed the following morning, when a 20-minute exposure is made at the non-focal point of the condensed light. On the third day Kime uses the light again at the focal point upon any part which has failed to respond to its irritative influence. The parts are thoroughly cleansed twice a day. In his monograph on the subject Kime submitted four photographs showing most excellent results.

Recapitulation.—Treatment with a sun lens while capable of securing extremely good results, is not so good as with an electric arc.

The concentrated visible chemical frequencies of solar light energy are useful in all of the skin conditions in which the electric arc has been found to be of service as set forth in Chapter XII., *The Concentrated Chemical Frequencies of Electric Arc Spectra*. The difference in effect is in degree not kind, and when the thermal energy of concentrated solar light is sufficiently eliminated from the latter, it is difference due to the greater proportion of the ultra-violet in the arc; a difference which is, however, compensated for to a considerable extent by the richness of the solar spectrum in the blue-violet frequencies.

Concentrated chemical solar light energy can also be used in suppurative and septic processes, as can the electric arc. It is a question only of the flexibility and adaptability of the means to the end. Experimental work and clinical evidence suggest that it is not as good in syphilitic lesions as the concentrated chemical energy of the electric arc. The same use of solar light which happily cured a tubercular laryngitis as quoted, failed in a case of syphilitic laryngitis. It is quite possible the author believes that the same happy result would have followed the use of a source of light rich in ultra-violet frequencies in this case. This point is fully elucidated in discussing the treatment of syphilis under the



concentrated invisible chemical frequencies of the spectrum or ultra-violet light energy (Chapter XVI.).

The literature of the therapeutics of concentrated and condensed chemical solar light energy is not as rich as that of the therapeutics of artificial sources of light, but the individual operator in possession of a sun lens will find that in practical work he may closely approximate by its skilful use the results obtained with the electric arc.

Treatment of Suppurative Keratitis by Solar Light.—Among those who have experimented with the sun lens may be mentioned E. Nesnamow.<sup>1</sup> His experiments were upon artificially provoked suppurative processes in the cornea. He used a concentrating lens similar to Finsen's, of 8 diopters and 10 cm. in diameter. Care was taken to exclude the thermal energy. Five severe ulcers of the cornea were treated for 2-5 minutes daily with the blue-violet frequencies of solar light with excellent results. To exclude the thermal energy Nesnamow filtered the light through a layer of water colored with methyl blue.

Concentrated Chemical Solar Light Energy in Tubercular Laryngitis.—M. Romme<sup>2</sup> quotes a report of M. Sörgo to the Society of Internal Medicine of Vienna, in which the latter reports the case of a patient with well-characterized tubercular laryngitis. He concentrated solar rays, by means of the laryngoscope, upon the ulcerated mucosa of the larynx. At the end of 30 séances of this laryngoscopic phototherapy, of which each had a duration of about an hour, the vocal chords had recovered their normal color, and the tubercular ulceration was cicatrized.

The healing of a tubercular laryngeal ulcer was established in the author's experience in two weeks without any direct application of the light activities. In this instance,

<sup>1</sup>Westnik Ophthalmologie, 1901, Jan. and Feb. cf. Dworetzky Zeitschr. s. diät. u. Phys. Th., Vol. V. Part III., also Amer. Med., May 31, 1902.

<sup>2</sup>Desiccation and Phototherapy in the Treatment of Granulating Wounds, by M. Romme.

Revue Internat. d'Électrothérapie et Radiothérapie, Jan., 1904, abst. from Presse Medicale.

however, the electric arc was used, giving the maximum of ultra-violet energy. In the latter there are available many more of the intrinsically valuable chemical frequencies, and as a source of light it is much more flexible and amenable to control than sunlight. The latter is uncertain, not only hiding its radiant energies oftentimes when needed, but also because of one's inability to control the position of the beam of light, and hence its focal point in a sitting of any length. Often, at least an hour is required for a sitting, and this means constant attention on the part of the physician or his assistant, as the lens will have to be continually moved, vertically, horizontally and up and down. It is a tax upon the physician's time and the patient's endurance and patience. But in the absence of a source of E. M. F., rendering it possible to use an electric arc, it is eminently worth while. Its advantages compensate for its disadvantages. It is portable, can be used at a patient's house, as well as at the physician's office, and is well adapted to a country practice. In latitudes where the sun is but little obscured by clouds, as in the more southern climes, it is pre-eminently useful.

In this field Kime has been an indefatigable worker, a brief résumé of whose methods and results in the use of concentrated chemical solar light energy (1) by means of the sun lens in skin lesions and (2) by the use of reflecting mirrors in tubercular pulmonary lesions is given.

The Concentrated Energy of the Visible-Chemical Frequencies of the Solar Spectrum in the Treatment of Lupus and Other Chronic Skin Affections.—Kime<sup>1</sup> prefaces a report of a series of cases treated by means of solar light energy, and the manner of its use by the statement that "light and especially concentrated actinic light derived from the sun, is a specific in the treatment of lupus, chronic ulcers, and other destructive lesions of the skin."

The Concentrated Energy of the Visible Chemical Frequencies of the Solar Spectrum in the Treatment of Pul-

---

<sup>1</sup>The Journal of the American Medical Association, April 11, 1903.

monary Tuberculosis, Concentration by Means of Mirrors. —Kime has also contributed two very valuable papers upon this subject. In the last<sup>1</sup> one, after calling attention to the physical characteristics of light energy and its physiological action, he gives the following description of his method for utilizing sunlight in pulmonary tuberculosis: A concave reflector, 36 inches in diameter, overlaid with blue glass, focuses a strong blue light upon the surface of the chest, made bare for two hours each day. This light is sufficiently strong to thoroughly illumine the lungs. Patients thus treated (using all other adjuvants of known value in the treatment of tuberculosis), Kime finds respond more quickly, and a greater percentage of recoveries takes place than under any other method of treatment with which he is familiar. Even cases far advanced begin to show improvement almost immediately, and from his experience he is convinced that but few cases in their earlier stages may not be permanently arrested. This statement is made from a personal experience of a number of years, and is based upon a sufficient number of cases to warrant its truth.

Since his first report Kime has removed to Denver, where he has a maximum of sunshine. There he has his skylight constructed of blue glass, but the reflectors are not overlaid with it.

The following is the order in which improvement occurs: loss of chills and night sweats; gain in body weight; increased appetite; lessening and disappearance of diarrhoea if it is present; increased strength, as a rule, rapidly, and ability to walk considerable distances as against short distances before; diminishing cough without the use of medicines; declination of febrile conditions in from a few weeks to 2 months or more, and after 2 or 3 months a return to the normal, where it remains. Bacilli are almost the last evidence of the disease to disappear, as they were also the first factor in the production of the disease. Frequently patients

---

<sup>1</sup>New York Medical Journal and Phila. Med. Journal, April 30, 1904.

leave the sanitarium with bacilli still remaining, and when they return a few months later the bacilli are found to be absent from the sputum.

The concentrated energy of the solar spectrum does not seem to have been availed of to such an extent by any one person as by Dr. Antonio Sciascia. In his published work Sciascia<sup>1</sup> used an instrument of his own device to which he gave the name of *Fotocauterio*. His instrument is designed for the condensation of the chemical and thermal energy of solar light. The lenses are of glass, biconvex, therefore, so far as the chemical energy is concerned, it is the visible chemical frequencies only which are used. But as few invisible or ultra-violet frequencies are available in solar light it does not so much matter. By the use of different sized lenses, from 1 to 4 ccm. in diameter, areas of varying size were treated, and by the interposition of different colored glasses, the energy of one part or another of the spectrum was used at will. It is also capable of regulation as to focal distance so that the focal spot may be used near to the apparatus or projected at a greater distance, according to the condition to be treated. Because of the wide and unusual range of diseases subjected by Sciascia to the action of solar light energy, the care with which his cases are reported, and the results obtained the author has thought best to introduce them into this text to stimulate and guide others in their work.

There is found in a personal experience corroboration of much of Sciascia's work. To secure the same results requires an intelligent, skilled and patient use of the energy of solar light, with which southern climes especially are so bountifully provided by nature.

From 1890 to the present time Sciascia has been able to record 28 cases of malignant pustule, more or less serious, all cured by the action of light energy. The following cases are types of the series :

---

<sup>1</sup>La Fototerapia. Roma. Société Editrice Dante Alighieri, 1902.

Malignant Pustule—Case I.—A. C., 28 years old, a shepherd of sound constitution; has had no sickness worthy of note.

Presents a pustule upon the left cheek, dating about 4 days. In the centre of the same is a necrotic area, 3 millimetres in diameter, surrounded by a number of vesicles of various sizes (from a hemp seed to a pea). The cutaneous tissue which surrounds the pustule is in a condition of acute tumefaction, which extends to the boundary of the face and on the neck, as far as the supra-clavicular fossa of the same side. Several days before he fell sick he had skinned a sheep dead of carbuncle. About the third day of his sickness he became feverish. He was sick and livid, prostrated with fever—T.  $39^{\circ}\text{C}$ . P. 120, R. 42. The local lesion tended to diffuse with rapidity, causing an impairment of the general condition.

Treatment—First day.—Exposure for one hour of the diseased area to the concentrated and condensed energy of solar light. (The thermal energy was utilized as well as that of the visible chemical frequencies.—The author.)

During the luminous projection the rupture of the vesicles begins with the discharge of a turbid whey, and the vascular cutaneous rete becomes swollen; by degrees the more delicate capillary vessels dilate, the swollen cutaneous tissue from livid becomes rosy, and begins to exhale a moist vapor, visible to the naked eye, with gradual reduction of the swelling, the local pain is relieved, and the temperature is diminished.

Second Day.—An eschar is noticed at the necrotic point, it extends but more superficially at the site of the vesicles destroyed the preceding day. At the periphery of the new necrotic area are seen some new phlyctenules much smaller than the former. The swelling is much reduced, the pain relieved, the fever reduced. The action of the second application of the solar energy is the same as on the preceding day.

Third Day.—A limitation of the eschar is noticed; no

appearance of new vesicles. The carbuncle-like swelling is much reduced, less pain, no more fever. The action of the third application was like that of the preceding. The exposures were repeated for 10 more days, at which time repair had taken place with disappearance of the eschar. A small unnoticeable scar remains.

Case II.—A woman, 60 years old. In addition to having a lacerated contused wound upon the forehead is reported to have handled the flesh of animals dead of carbuncle. After 10 days a malignant pustule appeared in the same locality as the wound, appearing like a scar.

Clinical Report.—On the pre-existing wound is observed a gangrenous eschar, with some small carbuncle-like vesicles at the periphery, full of a turbid, bloody whey; the face is invaded by œdema; acute pain is experienced especially in the left orbit-palpebral region near the pustule. The patient is feverish, T.  $38.5^{\circ}\text{C}$ .

Treatment—First Day.—Deep cauterization of the pustule with the solar energy.

Second Day.—The patient is without fever; the local inflammation is much improved; the carbuncle-like eschar is limited, the vesicles entirely destroyed.

Third Day.—The improvement of all the symptoms is progressing; the necrotic crust begins to separate at the periphery, and the action of the light energy is like the preceding day.

Four more applications of condensed white light, Tem.  $50^{\circ}\text{C}$ . on alternate mornings are sufficient to produce a definite cure.

Case III.—A shepherd, aged 40, presents a carbuncle-like eschar on the left forearm, dating since 7 days, of round shape, diameter 2 cm., with some small phlyctenules near the periphery. The inflammation extends through the entire arm, the axillary lymphatic glands of that side are swollen and painful. Patient is feverish, Temp.  $38^{\circ}\text{C}$ .

Treatment.—One deep cauterization with concentrated solar light, at the maximum degree of temperature on the

malignant pustule was sufficient, with a daily application of white condensed light, T.  $50^{\circ}\text{C}$ . and a complete cure was obtained in 20 days.

Case IV.—G. G., 18 years old, shepherd. No previous illness. Ten days after he had skinned a goat dead from carbuncle, a pustule developed below the left labial commissure, where a small ulcer pre-existed. He treated the matter as though it was nothing, neglected to consult any physician, although by the fourth day he was feverish. Nevertheless he waited two more days, "trusting to the help of nature."

On the sixth day he came under observation for the first time, and was in a "condition of great embarrassment."

The pustule is surrounded by phlyctenules of various sizes. In the centre is a necrotic area of the diameter of a centesimo (the coin equal to the size of an old-fashioned American cent), which invades the entire thickness of the tissue as far as the oral cavity. The swelling is acute and painful to pressure, extending over the face and neck. The oral mucosa which surrounds the eschar begins to resent the spread of the process. The patient is cyanotic, drowsy, in a state of collapse, with cold extremities. The respiration is stertorous, pulse almost imperceptible, T.  $36^{\circ}\text{C}$ .

Treatment—First Day.—In a dangerous condition, and a fatal result imminent, it was therefore necessary to have a recourse to more energetic medication than usual, namely, photo-cauterization of the pustule and to make a distribution within the carbuncle-like seat of inflammation of the vapor of iodine, to impress with more facility the auxiliary therapeutic action of the iodine and to push the iodine in a gaseous state through the circulation. Moistening then the pustule with iodine, an application was made with the photo-cautery, which allows the maximum concentration of solar light to the moistened necrotic eschar, to an area of half a centimetre. A sufficient temperature was used to cauterize the pustule deeply, and to vaporize the iodine. The rupture of the phlyctenules with the discharge of a turbulent san-

guinolent whey was also produced. The alimentation is by rectum, consisting of milk, eggs and coffee.

Second Day.—The patient responds to all questions; can swallow, his pulse is somewhat raised, T.  $39.3^{\circ}\text{C}$ . The eschar extends less deeply, as far as the site of the destroyed vesicles; the swelling, redness and pain are much reduced. The application of chemical condensed light for an hour obviates the necessity for further photo-cauterization. During the luminous projection the patient noticed a local comfort with relief of the pain.

Third Day.—No fever, everything is relieved. The necrotic tissue is beginning to detach at the periphery. The action of the usual application is the same until the 10th day, when there is a detachment of the necrotic tissue. A sinus remains which communicates from the outside with the oral cavity, the borders of this are granulating. With the continuation of the light energy until the 20th day there was the healing of the sinus and the small cicatrix seen in the photograph. These 4 cases are photographically illustrated in the original, pictorially vouching in every instance for the result obtained.

Pertussis.—Dr. Sciascia has also recorded 60 cases of pertussis, 50 children and 10 adults, all cured by the use of condensed light energy. He has observed that the condensed light acts as an antispasmodic and shortens the duration of the illness. Two illustrative cases are given:

Case I.—S. G., 3 years old, is harassed with pertussis in the convulsive period. It was the 15th day of the disease. The prodromic period occurred with fever and symptoms of simple bronchial catarrh, lasting for 10 days.

Clinical Report.—The child is without fever, hoarse, panting, with swollen face and ecchymotic spots under the conjunctiva. The crises of the convulsive cough were in classical form, occurring 12 to 16 times in the 24 hours. They were of long duration with frequent vomiting. The nose was filled with a thin sanguinolent liquid; the mucosa of the vaso-pharyngeal-epiglottic cavity was hyperæmic; in



the right supraclavicular fossa were felt nodular kernels of various sizes which extended deeply near the thoracic organs.

Treatment—First Day.—Application of chemical condensed light, in an area which uniformly irradiated the face, the neck and the chest, producing an abundant sweating and frequent sneezing with epistaxis. The child cried under the stimulating influence of the condensed light, and this penetrated the pharynx without the need of a tongue depressor, producing a hypersecretion of the thin mucus.

Second Day.—Nothing new is observed. Exposure to the light energy is repeated for an hour, as on the preceding day, producing the sweating and sneezing without epistaxis.

Third Day.—A great amelioration was observed. The crises of the pertussis begin to be more rare, and without vomiting. The same method was continued for 8 more days and a definite cure of the pertussis and the resolution of the engorged glands was obtained.

Case II.—A girl of 10 years was brought in after 20 days of the sickness, harassed with an obstinate pertussis with grave symptoms. The prodromic period was about 10 days, with fever, and simple bronchial catarrh. The physician had exhausted the arsenal of rational pharmaceutics without result.

Clinical Report.—The child is anæmic, ill-nourished, sunk in a profound languor, tending to inanition. The fits of convulsive cough are in classical form, frequent and of long duration. The naso-pharyngeal-epiglottic mucosa is hyperæmic, with adenopathy of the right cervical region extending to the supraclavicular fossa of the same side.

Treatment.—Application of chemical condensed light in the pharyngeal region, with the tongue depressed, which produced an abundant secretion of mucus, and profuse sweating. An application of the same strength which included the face, the neck and the anterior part of the thorax was made for an hour. After two days a cessation of vomit-

ing, a mitigation of the fits of convulsive coughing with an amelioration of the other symptoms was noticed. Eight other sittings were sufficient to produce a complete cure of the pertussis and the resolution of the engorged glands.

Tuberculosis.—In several forms of tubercular lesions, the results were excellent.

Lymphangitis Tuberculo-Gummatosa.—G. S., 18 years old, with positive hereditary antecedents. She had a torpid nodular swelling at the articulation of the left elbow. She had trusted for her treatment to the ill-advised exercises of a poor ignorant woman of her country, a serious maltreatment complicating a phlegmonous, suppurating peri-arthritis, which opened spontaneously on the external part of the articulation with a discharge of pus and caseous detritus, according to the report of the attending physician. At that time there was left an incurable opening.

Clinical Report.—The disease dated from 7 months. The young woman was emaciated with fever. She presented a torpid ulceration at the articulation of the left elbow, antero-external region, periarticular, extracapsular with flabby edges, thick and full of lumps and with different subcutaneous sinuses which extend to the middle of the forearm. The morbid process tends to spread in the periphery and deeply. Moreover, at the lower part of the sternum in the vicinity of the Xiphoid appendix a little to the right is observed a tuberculous gumma, the size of a dove's egg, which is beginning to soften. The overlying skin is reddish and tends to thin out.

Treatment.—To fill up the ulcerated cavity at the elbow with a powder of iodine mixed with potassium iodide, and with the photocaustery project the maximum concentration of the sun's rays to heat the powder of iodine, producing an azure light with the developing of iodine vapor while deep cauterization occurs.

The tubercular gumma on the chest was treated with the photocaustery, until the production of an eschar. This detached itself after the second day with discharge of a thin

yellow liquid mixed with caseous detritus. Then the cavity was filled as usual with powdered iodine, which was treated by the photocaustery to produce a deep cauterization down to the sound tissue. This operation was repeated 3 times with an interval of 20 days, besides 20 sittings with chemical condensed light. After 3 months the cure was complete. The articulation of the elbow remained unhurt. At the end of 5 years it has not relapsed.

Tubercular Poliadenitis.—V. M., 10 years old, with bad history. Presents a chain of glands which occupies the right cervical region to the supraclavicular fossa of the same side. The glandular kernels are of various sizes, from a pea to an almond; some are swollen, others caseous or ulcerated. The morbid process tends to spread with the appearance of new glandular nodules of the same kind in the neighboring organs. The general condition shows a progressive wasting.

Treatment.—Local application of an area of chemical light for an hour a day. Sixty sittings are required to obtain a cure.

Observation.—The glands in the condition of simple inflammatory swelling came to full resolution; those that suppurated became caseous and ulcerated. On account of the cicatrization they are destroyed and eliminated more slowly by a natural work of a morphological process, in the same way as the eliminations of tuberculosis and lupus.

In 12 other individuals affected with the same disease Sciascia obtained the same result.

Tubercular Peritonitis.—M. L., age 9 years. Etiology positive, was a case of tubercular peritonitis treated successfully by means of concentrated light energy. The patient, a child, presented the classic symptoms as well as typical physical signs. There was anæmia, ascites, enlargement of the abdominal lymphatic ganglia, vomiting, anorexia, vague abdominal pains, intestinal disturbance, scant urinary secretion with trace of albumin.

\* A general application of the light was made to the entire

abdominal and thoracic region for an hour on alternate days. Gradually after three months there was resolution of the ascites and enlarged lymphatic ganglia, with improved nutrition. After five years the patient was still well.

Pneumonia.—In 12 cases of croupous and catarrhal pneumonia, good results are reported. A typical case is the following:

Lobar Pneumonia.—D. N., a countryman 40 years old. Presents a pneumonitis of the superior lobe of the right lung dating from 4 days, with general symptoms of adynamia. Upon auscultation is heard an accentuation of bronchial breathing, upon percussion an area of dulness is discovered in all the region of hepatization of the lung; the cough is frequent with difficult expectoration of a prune-colored secretion. T.  $40^{\circ}\text{C}$ ., P. 130, R. 40; the urine is loaded with urates, and contains albumin, the compensatory respiration is impeded by collateral œdema.

Treatment.—Daily applications of chemical light in the right region of the thorax for half an hour; afterward provoking the nasal reflexes with the thermic light energy, T.  $52^{\circ}\text{C}$ ., to facilitate the expectoration through the reaction upon the “fibroid cellules of the lung.” By the third day the hepatization begins to resolve, the crepitant rattling to return, heard in the posterior part. The cough is less frequent with easier expectoration. The fever is less. T.  $38^{\circ}\text{C}$ ., and the collateral œdema has disappeared. At the fourth sitting, after the crisis of a copious sweating the defervescence of the fever occurred and complete resolution of the pneumonitis. There remained during the convalescence a mild pulmonary catarrh, which was not of long duration.

Diphtheritic Croup.—Six cases were treated by the condensed light energy, with recovery.

Descending Diphtheritic Croup.—V. L., 5 years old. No previous sickness worthy of note.

Clinical Report.—The sickness has lasted 3 days with fever, malaise, pain in the throat, and difficulty in swallow-

ing. The mucous membrane, which covers the tonsils and palate, is covered with false membrane, the nose discharges a yellowish serum, sometimes bloody; the neck is invaded by a swelling; the urine contains traces of albumin. On the fourth day a hoarse cough developed with progressive restlessness and shortness of breath.

On the fifth day there was dyspnoea, suffocation, supraclavicular depression on inspiration and threatened asphyxia with an imperceptible pulse.

Treatment—First Day.—Application of chemical condensed light to the naso-pharyngeal-epiglottic region, causing a hypersecretion of mucus to facilitate the elimination of the false membrane, reduced to a pulp by the action of the light. There is sneezing with epistaxis. In consequence of the sneezing and the sweating the respiration becomes freer, and the general symptoms are relieved.

Second Day.—The false membrane is not reproduced, the fever is milder, the cough is less; the circulation and respiration improved, and the glandular engorgement tends to resolution. Six other applications of the light energy were repeated on alternate mornings, gradually producing a cure. A slight degree of hoarseness and a catarrhal cough remain for two weeks. Six other cases of equal seriousness were treated with the same method, recovering in longer or shorter time.

Nervous Diseases.—In chorea minor, Dr. Sciascia has treated 20 cases with success, 16 girls and 4 boys, from 6 to 15 years old. Neuralgias and hysteric conditions are also reported as cured. Typical cases are given in detail:

Chorea Minor.—A. C., 13 years old, a peasant.

After prodrome of the disease with psychic disturbance he was taken with incoördinate, involuntary movements, especially on the left side.

Clinical Report.—The sickness dates from 6 months. Shows irregular motions of the head, of the muscles of the face, and of the limbs; sometimes a contraction of the extensors, at other times a flexion and raising of the shoulders.

The patient is not able to stand on his feet on account of the manifold incoördinate movements, which complicate 3 or 4 groups of muscles in different regions at the same time, and cannot be controlled by the will. He stammers and slights his vowels, and cats with a convulsive motion. Sensibility to heat and pain is diminished in the left lower limb.

Treatment.—Application of an area of chemical condensed light which includes uniformly the head and vertebral column for an hour, producing a copious sweating, and relief from the spasmodic action. Ten other applications were sufficient to obtain gradually a definite cure.

Sciatic Neuralgia: Basedow's Disease.—M. C., 37 years old, multipara, of weak constitution, habitually neurasthenic.

For 6 months she has been harassed by pain in the left side. At first it prevailed principally in walking, now it is insupportable during repose.

Clinical Report.—Presents exophthalmia, hypertrophy of the thyroid and tachycardia. The pain is paroxysmal and obstinate in the left thigh, accentuated during the night with phenomenal intensity. The points of pain are sacro-iliac, trochanteric, popliteal and malleolar. Laségue's sign exists.

Treatment.—Every kind of medical treatment had been employed "with discernment" in the treatment of the sciatica without result.

First Day.—With the solar energy the work of cauterizing *trascorrente* (running over), according to Valleix, for the first time, and then the daily application of chemical condensed light of a uniform area, which comprehended the left lumbar, popliteal and malleolar regions for an hour, alternating the thyroid body and the cervical ganglion of the sympathetic.

Every application produced copious sweating with progressive alleviation of the pain, gradual decrease in the paroxysm until the thirtieth sitting; after that she had a definite cure of the sciatica and a relief of the cardiac symptoms depending upon the Basedow's disease.

Tic Douloureux.—I. C., 57 years old, healthy. For 4 months he was affected with an acute pain, spasmodic and insupportable in the lower part of the left cheek in the labio-mental region.

During the attack every slightest movement in speaking and chewing, or the lightest touch upon the point of pain, was impossible. No movements or other manœuvres occurred in the intervals of pain. The objective examination shows that the seat of the trouble is in the third branch of the trigeminal nerve, at the exit of the inferior dental nerve. The cause of the hyperalgesia is the irritation of the mental plexus and the fibres of the facial which cross it, resulting in the clonic muscular contractions which complicate the neuralgia. The spasmodic pain is acute, frequent and rebels against all pharmaceutical treatment. Neurectomy is advised. For this the eminent surgeon, Dr. Carlo Gangitano, Professor of Clinical Surgery in Naples, was called. Before he intervened and the last resource was exhausted, the patient was sent to Sciascia's Institute for Phototherapy.

Treatment.—On the first day the photocautery, i.e., thermic solar energy for the work of "passing over" (*Tras-corrente*) cauterization according to Vallei, in the painful region of the inferior dental nerve was used, followed by the projection of a chemical condensed light over the spasmodic zone for an hour. This produced a profuse sweating and a general sense of well being. The spasms returned during the day with the same intensity, but less frequently. On the second day there was no need of photocauterization. With the repetition of the light chemical condensed treatment of the preceding day, a progressive amelioration was obtained, until the tenth sitting, and a complete cure was obtained. Thus the surgical operation was avoided, which would otherwise have been necessary, because the patient could not longer endure the pain of the sickness.

Peritonitis.—Two cases of peritonitis were treated with the condensed chemical light, with complete recovery of both.

Case I.—M. N., 26 years old, multipara, of good condition. For 6 months she had suffered with acute spasmodic pain in the abdomen, with frequent vomiting, hiccough, and vesical spasm.

Clinical Report.—There is a marked meteorism, with lancinating pain in the whole abdomen. It is impossible to make the least palpation on account of the painful spasm which it causes; the patient is unable to bear a light covering. Vomiting is frequent, micturition is spasmodic with the emission of clear normal urine. The pulse is small and quick, the respirations short, with frequent hiccough. All these symptoms are accentuated in the early morning hours, with convulsive twistings of the patient.

The æsthesiometer reveals a zone of hyperæsthesia in the left side.

Treatment.—Narcotics, emollients, warm baths, and all those things which are indicated for entero-peritonitis are of no value.

An application of chemical condensed light was made to the whole abdominal region for an hour. It produced a copious sweating with alleviation of the spasmodic symptoms. The pain in the early morning hours returned with its usual crisis, but with symptoms of less severity. She is able to bear slight manual pressure upon the abdomen without inconvenience. The phototherapy was repeated like that of the preceding day, with an amelioration of the general and local condition.

After two other exposures to the action of the chemical condensed light, she obtained a complete cure.

Five years have gone by without return.

Case II.—In a case of orrhymentitis (peritonitis) in a young woman aged 18, multipara, there was an exudative peritonitis with fever and gastro-intestinal disturbance. After a month a cough came on with dyspnœa, thoracic pains and hæmoptysis.

Clinical Report.—The illness was of 40 days' duration. She presented a pleuritic effusion in the right side. The



liquid occupied two-thirds of the thoracic cavity. The semilunar space of Traube had disappeared, the pericardium and the abdominal cavity showed a separate effusion. The distention was very great, as shown in the photographic illustration, and the countenance bore the expression of pain and distress. The patient was anæmic, badly nourished, and had febrile disturbances. Intense lancinating pains, retrosternal, interscapular and abdominal were experienced. There was cyanosis, an angina, hiccough, vomiting and disordered cardiac functions.

The concentrated light was applied by Sciascia on every alternate day for one hour upon the thoracic-abdominal region. Fifteen exposures were made in all. The first treatment was followed by copious sudation, a sense of well-being, and alleviation of pain. The patient made a complete recovery.

Sciascia also reports one case, each of abdominal typhoid, gastric ulcer, arthritis blenorragia, and puerperal metritis, in all of which good results were obtained from the application of the condensed solar energy to the region of the lesion. A series of psychical conditions are also reported.

## CHAPTER XII.

The Concentrated Energy of the Electric Arc Spectra, Carbon, Carbon and Iron, Iron. Mechanisms, Methods of Use and Therapeutic Indications. Finsen. Lupus Vulgaris, Lupus Erythematosus, Sycosis, Eczema, Tubercular Ulcers, Tubercular Glands, Neuritis, Neuralgias.

### The Concentrated Energy of the Electric Arc Light in Skin Diseases.

The most important use of the concentrated chemical frequencies of light in skin diseases, in a certain sense, is in the treatment of lupus vulgaris. In the last report of his Light Institute at Copenhagen, Finsen<sup>1</sup> gives a résumé of 800 cases treated. In these 800 cases there was improvement in 90%, cure in 70%, reappearance in 20%, the latter being generally cases where the mucous membrane was involved.

The following table gives a detailed analysis of the 800 cases:

I. Apparently cured	407	$\left\{ \begin{array}{l} 122 \dots \dots \dots 2-6 \text{ years} \\ 285 \dots \dots \dots 2 \quad \text{''} \end{array} \right\}$	51%
II. Nearly cured	193		24%
III. Marked improvement	89	$\left\{ \begin{array}{l} 24 \dots \dots \dots \text{partly} \\ 65 \dots \dots \dots \text{marked} \end{array} \right\}$	11%
IV. Not sufficiently treated	40	$\left\{ \begin{array}{l} 14 \dots \dots \text{not permanently} \\ 12 \dots \dots \text{some improvement} \\ 14 \dots \dots \text{negative result} \end{array} \right\}$	Improved 5%
III. Dismissed	71	$\left\{ \begin{array}{l} 33 \text{—died} \\ 13 \text{—sickness} \\ 25 \text{—did not return for treatment} \end{array} \right\}$	

<sup>1</sup>Mitteilungen aus Finsen's Mediciniske Lysinstitut in Kopenhagen, 1904.

Finsen is of the opinion that not more than 2% of tubercular lupus cases can be regarded as incurable. And Bie has said that a failure of a case to respond to the action of light energy is an indication of a wrong diagnosis.

As the arc light mechanisms in use for therapeutic applications to localized areas are arranged (1) to concentrate all the energy of the arc by means of reflecting mirrors on the area to be treated, and (2) not only to concentrate but to condense the energy of the arc by means of condensing or focal lenses, as in the Finsen and Finsen-Reyn apparatus, the author has chosen to consider both methods under the single head of the concentrated energy of the electric arc, for such it is in both instances, but in the latter condensed as well.

In the text, therefore, wherever the means to the end is referred to as the concentrated energy of the arc, there is to be understood the full energy of the arc concentrated, by means of suitable mirrors, to a beam of lesser or greater diameter, according to the superficial area of the part to be treated, but without focal lenses; on the other hand by the concentrated and condensed energy of the arc it is to be understood that the energy of the arc is used at its focal spot, and through focusing or condensing lenses of quartz, as per the method of Finsen.

Of the apparatus described in the following pages, the Finsen, Finsen-Reyn, and the author's arrangement of the marine searchlight, with a water-cooled chamber, formed by means of two focal lenses of quartz, are the only mechanisms by which the energy of the arc is not only concentrated, but condensed as well. The marine searchlight as ordinarily used, the Victor or London Hospital lamp, the iron electrode lamp, and the apparatus of Bellini are all arranged for concentrating the light, but not for condensing, i.e., with focal lenses.

The essentials for a light mechanism for the treatment of lupus vulgaris and other skin lesions, as per the method

of Finsen, or for the treatment of other conditions to be subsequently considered, are:

(1) A sufficient intensity of electric current which produces the luminous output.

(2) An effective luminous output on the skin of the patient: That is a beam of light rich in a complex of the energy of all the frequencies from the blue on up to the ultra-violet, which is at once both bactericidal and capable of exciting tissue reaction. By this complex of wave energy a deeply penetrating effect is secured, as well as the superficial action upon the skin, due to the absorption of the shorter wave lengths or ultra-violet.

(3) The losses of effective energy between the arc and the skin of the patient: This is by reason of the position of the arc and the relation of the patient to it, for the nearer the source of light the greater the energy. This is according to fundamental physical law, i.e., that the intensity of light varies inversely with the square of the distance, but it is a law which holds good only for non-concentrated light.

(4) The influence of the media traversed; that is, losses by reflection or absorption: All media, air, water, glass, even superimposed quartz lenses weaken the force of the energy from the arc. Mirrors even used to reflect the light are a source of loss, but act better than the small lenses of quartz. Silver mirrors, for example, reflect only 92% of the visible spectrum, while an alloy (41% Cu + 26% Ni + 24% Sn + 8% Fe + 1% Sb) known as the Brandes-Schümann,<sup>1</sup> reflects only 50%, but reflects ultra-violet more than other metals.

Mirrors of the Brandes-Schümann alloy take a very good polish, and resist the action of the air. Steel might also serve as a reflector.

Victor Schümann, to whose research is due the measurement of the shortest wave length yet recorded, is authority for the statement that metal mirrors of magnalia, an alloy

---

<sup>1</sup>Quoted by Freund from Physik Zeitschr., 1900, Vol. II, p. 176.

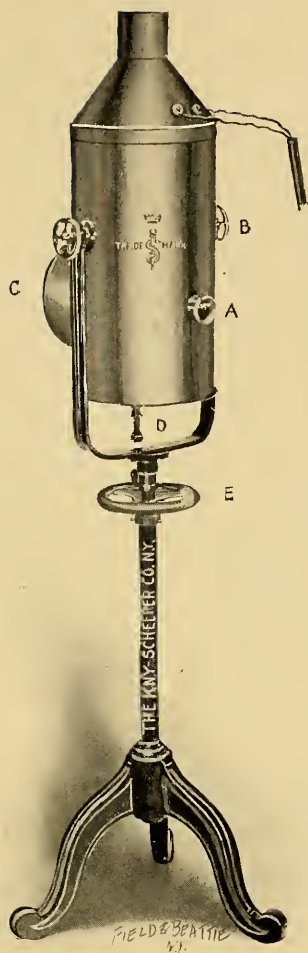

Fig. 54.—Therapeutic Arc Lamp of 25 to 40 ampères, direct current; requires no water cooling for shell; is very useful in skin diseases and other local conditions.



of aluminum and magnesium, reflect not only the visible spectrum, but the ultra-violet very satisfactorily.

(5) Compression to render anæmic the tissues to which the application is to be made must be considered in order that the effective energy need not be absorbed by the skin to too great an extent.

(6) A comfortable position of the patient in relation to the light mechanism is also a requisite, as well as a means of depriving the light energy of its heating effects.

The experiments of Bernard, Morgan, Freund, Bie, Leredde and Pautrier would indicate that the shorter and more frequent the wave lengths the more useful they are: (1) in bactericidal activity, (2) in exciting tissue reaction. On the other hand, the longer they are the deeper they penetrate. From this the conclusion is reached that the frequencies between the two extremes are the most useful, that is from the blue into the ultra-violet.

Nature of Electrode Contacts.—When the electrodes supplied to an arc lamp are either iron, or, in the author's judgment, iron incorporated into the mass of the carbons, there is a very marked contrast between the color, and that from carbon electrodes alone. The light from carbons alone is of a dazzling whiteness, while that from iron and carbon shades from an intense dead or blue white to a bright violet color. Iron is very rich in the violet and ultra-violet frequencies, but exceedingly poor in the longer and slower frequencies, and, therefore, of limited power of penetration. While these intense chemical activities are of the greatest value, they need to be associated with the longer wave length of that part of the spectrum known as blue, in order to secure the best results.

For several years the author has used lamps of from 25 to 80 ampères with the best carbons obtainable, carbons through which a core of wire in the shape of an iron rod has run axially, or electrodes in which iron has been incorporated in the mass of the carbon. The latter are the better, and they can be obtained in this country from the manu-

facturers of arc lamps, or directly from the carbon-electrode manufacturers or importer. As the spectrum of carbon is slightly deficient in blue, as compared with solar light, the addition of iron is an advantage. By this combination of iron and carbon a spectrum very rich in the visible chemical frequencies, or blue, indigo and violet, as well as the invisible or ultra-violet frequencies, is combined with that of iron. In this connection the following is of interest :

Arc Light Electrodes.—Recently Vogel<sup>1</sup> states that experiments for the purpose of ascertaining the chemical relations which take place in an arc light between carbon electrodes containing ingredients intended to increase the light, have determined that the acid fumes of metallic salts rather decrease it than otherwise, being bad conductors of electricity, and also poor dispensers of light. On the other hand, the conducting and light-emitting powers of alkaline, alkaline earth and rare earth metal fumes are very good, and the results of value, when the loss of energy caused by the vaporization of the substances is compensated for by the increased concentration of the gases, and the temperature of the arc raised by an internal chemical decomposition initiated by the introduction of free ozone. The essentially novel and characteristic feature of Vogel's invention, which produces the increased emission of light, is the separation, by means of a carbon partition, of the materials yielding oxygen from the light-emitting substances, and the central arrangement of these passages, in order that the oxygen may only reach the vapor of the illuminating substances after being ozonized.

However, if one recalls the photosphere of the sun, formed as it is of a "colossal storm of rain and hail, of liquid and semi-solid diamond," that is chemically pure carbon, and that life is sustained by the radiance from the photosphere, the conclusion is forced that, after all, there is nothing better for phototherapeutic work than electrodes of the purest carbon obtainable.

<sup>1</sup>The Electro-Chemist and Metallurgist, April, 1904.



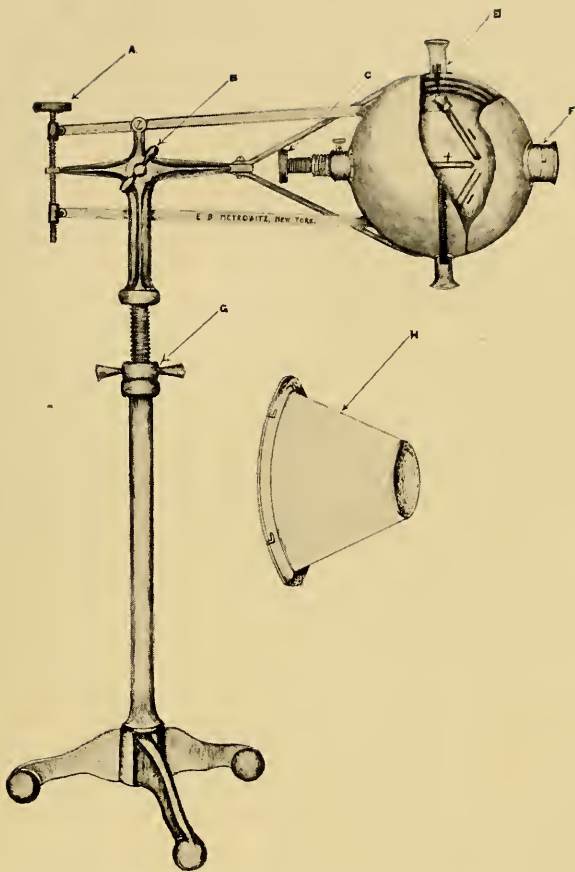

Fig. 55.—The Cleaves Arc Lamp—for alternating or direct current, local or general applications; requires no water for cooling shell; projects the light of the arc directly upon exposed area; ampères 40 to 70.



The Type of Mechanism Selected is Governed by the Nature of the Work to be Done, i.e., the Pathology.--The first point, then, to be considered is the arrangement of mechanisms to be used for the purpose of concentrating the chemical frequencies of light, or in the method introduced and practiced by Finsen, of not only concentrating but condensing the light frequencies as well. If the condition to be treated is one involving extensive and well-organized infiltrations, as lupus vulgaris, for example, then an arrangement of mechanisms utilizing to the full the chemical frequencies of a source of light, from 25 ampères upwards, should be selected, for here a great quantity of light is needed. They should be used preferably with focal lenses, for the maximum of energy is at the focal spot.

If, on the other hand, the lesion is more superficial and less well organized, a source of light of less ampèrage is sufficient, the small iron electrode arc lamps, for example, while in many recent and still more superficial conditions, a source of light giving ultra-violet frequencies only, as from the spark condenser lamp, is of value. This latter fact is due, as has been pointed out, to the fact that ultra-violet frequencies have very little penetrant power, and are, therefore, inadequate, where a profoundly penetrating effect is desired. With these latter mechanisms the use of focal lenses is not imperative.

To Finsen the profession is indebted not only for the careful preliminary study and investigation showing conclusively the rôle of these frequencies in skin diseases, but also for the application to therapeutics of a scientifically constructed apparatus for the use of concentrated electric-arc light energy. Similar apparatus had long been used in physical and medical laboratories. In the Vienna Institute of Experimental Pathology, apparatus constructed exactly the same had been used for many years to project light by Professor Paltauf, and formerly by Professor Striker.<sup>1</sup>

---

<sup>1</sup>Freund.

In his experiment as to the action of light, Widmark,<sup>1</sup> in 1889, made use of the same kind of apparatus. All of which is illustrative of the fact that the means to the attainment of a definite end in all matters of scientific development lie at our door awaiting the interpretation of and application by the intuitive intelligence. Such is the order of genius possessed by Finsen, and having proved by his experimental work the action of light he was at once able to

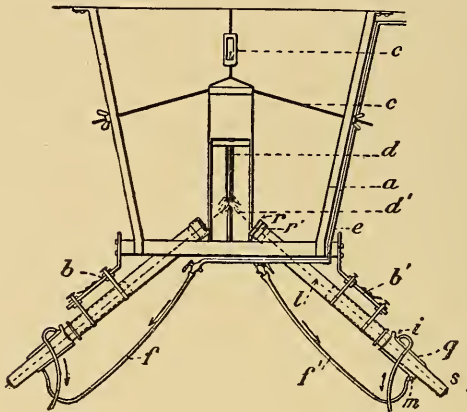

Fig. 16.—*a*, support of the apparatus; *b*, support of the tubes; *c*, support of the lamp; *d*, positive carbon; *d'*, negative carbon; *e*, water feed; *f*, *f'*, rubber tube for water inflow; *i*, rubber tube for water outflow; *m*, entrance of water into cooling chamber; *l*, tube with lenses; *q*, metal cylinder for the circulation of water; *r*, *r'*, lenses to render the rays parallel; *s*, lenses to render the rays convergent.

supply the needed apparatus for the utilization of the intense chemical frequencies of light energy from an electric arc. His first therapeutic applications were made with concentrated sunlight, but it was not possible to obtain in that way sufficient energy, and, moreover, in northern latitudes, as that of Denmark, the sun was not always in evidence.

Finsen's Concentrator.—Finsen's apparatus consists of a telescopic tube, by means of which the divergent rays of an electric arc are collected into parallel rays. These parallel rays are then collected into a cone, the apex of which is

<sup>1</sup>Quoted by Freund.

allowed to fall upon the part of the skin to be treated. Fig. 16 gives a diagrammatic cut of Finsen tube. This tube, which is the connecting apparatus between the source of light energy and the patient, consists of 2 metal cylinders telescoped one into the other, each one of which contains

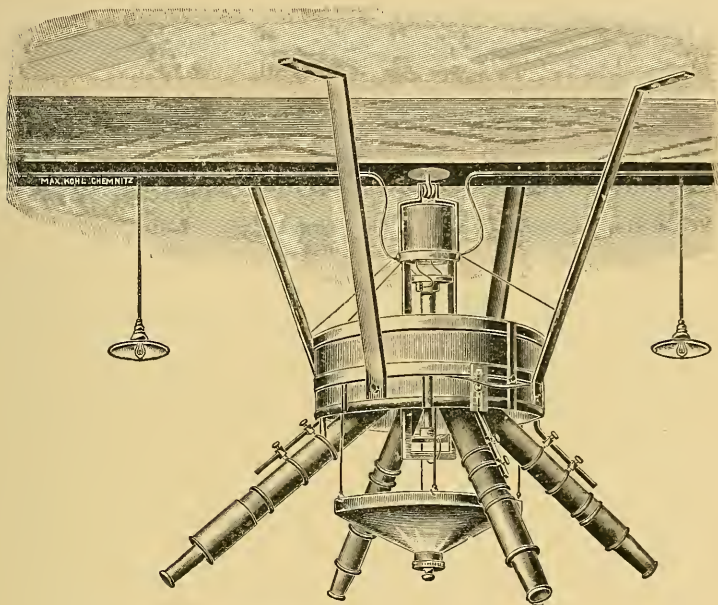

Fig. 17.—Finsen Apparatus.<sup>1</sup>

two plano-convex lenses of quartz. These two parts of the apparatus may be separated by a rack and pinion movement. The various lenses are so proportioned as to size that 1 and 2 have together a focal distance of 12 cm., while 3 and 4 have a focal distance of 10 cm.

By the lenses 1 and 2 nearest to the source of light, the divergent rays of the electric arc are gathered into a bundle of parallel rays; then by the action of the lenses at 3 and 4 these parallel rays converge on the surface to be treated. This is about 10 cm. outside of the lens marked 4. In the

<sup>1</sup>From Freund, Radiotherapy and Philotherapy.

original tube the water chamber was fixed between lenses 3 and 4, and kept filled with distilled water for the purpose of absorbing the thermal frequencies: This part of the cylinder is in turn surrounded by an additional chamber through which, by an afferent and an efferent system of rubber tubes, connected with the source of water supply, cold water is kept circulating through the mantle surrounding the water chamber at the distal end of the tube.<sup>1</sup> Otherwise the water becomes boiling hot.

Alternating Versus Continuous-Current Arcs for Concentrating and Condensing Light Energy.—For his source of light energy Finsen uses a continuous-current electric arc of 80 ampères. He estimates its light intensity at 40,000 candle-power. An alternating-current electric arc is not suitable where concentration of the light energy is desired, for, as has been pointed out under the physics of the electric arc, there is no longer a continuous flame, but the arc is alternately lighted and extinguished at every reversal of the current. The light is, therefore, unsteady and unsuitable for concentration.

Resistances to Cut-Down Voltage.—The E. M. F., 110 volts, of the continuous-current as supplied from the street mains, is greater than is required for the operation of an electric arc. This is true whether an arc of 80 ampères, or arcs of greater or less ampèrage are used. In the author's use of an 80-ampère arc to operate a Finsen tube a suitable resistance or rheostat capable of using up the extra voltage is used. This is also done with 25 and 50-ampère arcs.

The Necessity for Heavy Wiring to Carry Large Currents.—The wiring for arc lamps must be heavier, i.e., capable of carrying greater ampèrage than for the ordinary electric lighting of dwellings. This varies according to the current consumed by the arc. For an 80-ampère arc a heavy, well-insulated wire is required.

---

<sup>1</sup>Vlademar Bie, *The Phila. Med. Journal*, Oct. 4, 1899.

Not Only Light Requisite but a Quantity of Light.—In the selection of an electric arc lamp the reader will recall that it is not only light that is needed, but a *quantity* of light, and that the amount of light is not increased per unit of area with the current, but the size of the crater is increased, which increases the amount of light emitted. This is true with given carbons at a given distance apart. With both ampèreage and larger carbons, there is still a further increase in the size of the crater, and consequently in the unit of area, which means still more light, and especially more of the valuable short and high frequencies so active chemically.

The Position of the Finsen Apparatus in Relation to the Arc.—Finsen's 80-ampère arc is suspended from the ceiling (or it may be adjusted upon a very high table if desired, either iron or iron-covered). In the Finsen Light Institute the arc is suspended from the ceiling, as is shown in Fig. 17. There are arranged around a single lamp, four of the concentrators or tubes described, each in turn being secured to an iron in order to utilize its energy for the simultaneous treatment of four patients. This ring in turn is fixed to the ceiling by four iron supports. The spaces between the single concentrators are filled with asbestos plates, in order that the operators and patients may not be exposed to the action of strong light.

The apparatus is movable up and down as is shown by the pendant drop attached to an arrangement of pulleys. The concentrators are adjusted at an angle of about 45 degrees in relation to the arc, because it is at this point that the greatest energy of the arc is to be obtained. In this way the points of the carbons are exactly in the focus of the proximal lenses of all four of the concentrators.

Water Cooled Compressing Lens.—As the light, however, from this doubly cooled apparatus, i.e., water chamber and superimposed mantle or jacket, still produced too great heating effects, Finsen devised a hollow compressor consisting of a plate of quartz and of a plano-convex lens of

quartz both framed in a conical brass ring, carrying two small tubes and four arms. To each arm elastic bands are secured in order to adjust the compressor with equable pressure to the part to be treated, while the two small tubes connected with the interior chamber of the compressor are again in turn connected to a source of water supply by a system of efferent and afferent tubing providing for the constant circulation of cold water. In this way the remaining heat is done away with, while at the same time from the firm and equable

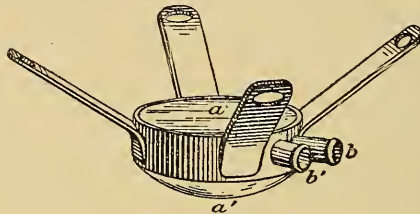

Fig. 18.—Compressor; *a*, *a'*, lenses of quartz; *b*, tube for the inflow of water; *b'*, tube for the outflow of water.

pressure upon the part to be treated the blood is driven out, rendering it anæmic, in which condition absorption of the chemical frequencies is assured. If elastic bands do not suffice to maintain it in position a suitable arrangement of bandages may suffice or it may be held by the operator's hand.

The Necessity for Lenses or Plates of Quartz.—In his first apparatus Finzen used glass lenses, but later on replaced them with lenses of quartz because of the physical fact that ultra-violet frequencies are absorbed by glass. The physical reason for the transparency of the one and the opacity of the other the reader will recall is given in Chapter II., the Physics of Light Energy.

It is only feasible to get quartz lenses of small diameter. The larger ones are not only difficult to get but very expensive. This is due not to the expensiveness of uncut quartz but the difficulty encountered in accurate and even cutting of lenses or plates, but especially the former. Quartz is very



prone to break along its lines of crystallization and the cutter never knows when this accident may befall. The author has been informed that as much as a ton of quartz was used before a perfect single focal lens of quartz 2 inches in diameter was obtained. Moreover, it is impossible to utilize to the best advantage the energies of the electric arc with small lenses. This fact, in connection with the powerful arc required for the successful operation of the Finsen tube, the distance of the distal end from the source of light energy, the expense of current consumed and the long sittings required, at once led different investigators and manufacturers to construct apparatus which not only would not have these disadvantages but would have greater merit. With a Finsen tube and an 80-ampère arc the author found it necessary to make exposures of from one to two hours in duration. The tax upon the patient's endurance was very great as well as upon that of the operator, while the expense of current was enormous. These are factors which do not necessarily enter into Finsen's work, as it is supported by the Government. In a private office, however, it is another matter. But while ampèrage is desirable, it is not the only factor, as has been pointed out under the physics of the electric arc. Suffice it to say that with the Finsen tube a considerable part of the effective energy is lost in passing through the water-containing cylinder, and the unavoidable use of so many lenses weakens the force of the energy which is allowed to pass.

The Lortet and Genoud Apparatus.—One of the earliest and, at the same time, the best practical substitute which appeared was the Lortet and Genoud lamp, manufactured at Lyons, France. The following description of this apparatus was written by the author in 1901.<sup>1</sup>

The continuous current electric arc is produced between two carbons forming an angle sufficient to allow the crater of the positive carbon to project the greater part of the light in

---

<sup>1</sup>The Electric Arc; Its Physics, Physiological Action, Therapeutics and Arrangement of Mechanisms. Margaret A. Cleaves, M.D., *The Journal of Physical Therapeutics*, July 10, 1901.

a cone, whose axis passes through the centre of an orifice. The orifice is situated in the centre of a sort of vertical basin with a double bottom, the walls of which, about a quarter of an inch apart, leave a space for the constant circulation of water. This water prevents the heating of the basin, which acts merely as a screen, and is provided with an orifice through which the light passes. A system of jointed arms and screws permits of the regulation of the arc, which may be brought within variable distances of from one-half to three-quarters of an inch from the orifice. The carbons are concealed by the flanges of the spring, and a small mirror prevents any projection of light to the rear. In front of the orifice there is fixed a sort of hollow shutter, limited upon its two faces by discs of rock crystal, in the interior of which circulates a current of water. The electric arc may be brought to within  $2\frac{1}{2}$  inches of the shutter without the latter becoming heated. The apparatus is mounted upon a rod movable in all directions, so that the manipulation of it is rendered very easy.

With this apparatus it is possible to utilize the full energy of the high frequency waves of the arc, for by the absence of condensing lenses, and the nearness of approach to the patient little, if any, opportunity is offered for their dispersion.

By the Position of the Carbons the Light of the Arc, or Blue Mist and Reflection from the Crater is Secured.—The position of the carbons at an angle of 45 degrees is also a factor for the light of the arc proper or blue mist is fully exposed to the inner quartz plate, the crater of the positive electrode serving at the same time as a reflector. This is most important, for, as has been noted, the chemical rays have short wave lengths and high frequencies, and can agitate little things in their path, such as molecules, and as this agitation is what is assumed to effect chemical change, it is most important that every opportunity of dispersion of activity in transit from the source to the patient should be minimized. With this apparatus, Lortet and Genoud find that

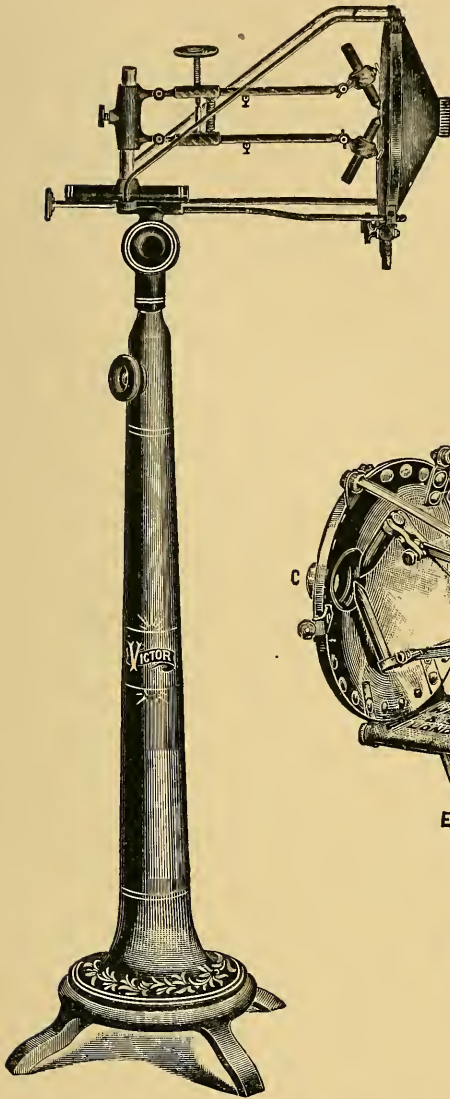

Fig. 19.—Victor Lamp.

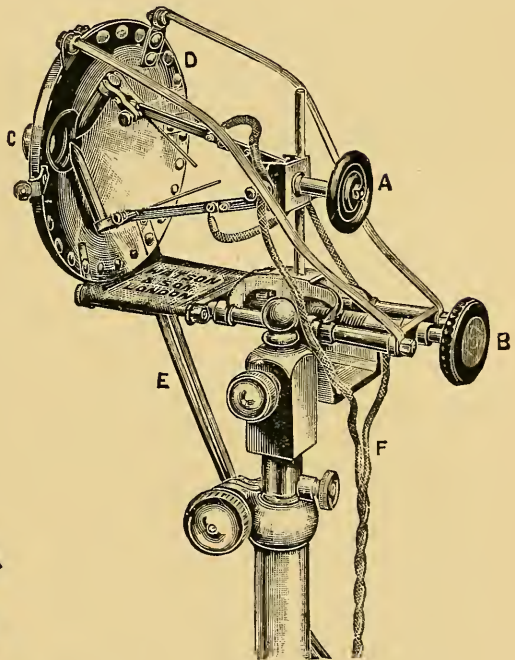

Fig. 20.—Lortet et Genoud Lamp.

an exposure of from 15 to 20 minutes suffices against an hour and a quarter with the Finsen tube. \* This is due to the securing of a residual beam of much greater total energy than is obtained from a tube with condensing lenses of quartz. This residual beam, to be properly effective, must possess the greatest possible number of high frequency waves of considerable amplitude, a beam not only of high intrinsic energy, but greater total energy. As the amount of work accomplished always depends upon the amount of energy expended, it follows that a shorter exposure should give equally, if not better results. But one factor minimizes this effect, and that is the absence of condensing or focal lenses of quartz, as will be shown in a comparative estimate of different light mechanisms. They are, however, supplied by the manufacturers. The effect desired in lupus, for example, must be produced by the maximum of chemical activity, which means not only a maximum intensity of the very high frequencies, but a complex of all the frequencies, waves of greater length and amplitude as well as those of shorter length and less amplitude. In less resistant pathological conditions, so to speak, as in the stimulation of a simple ulcerating surface, a chemical effect produced by a less intensity would be sufficient.

The apparatus of Lortet and Genoud is commendable also from the practical point of expense. It can be constructed at one-third the cost of a Finsen tube, and as the length of exposure is reduced by reason of the total energy, the cost of current is proportionately reduced, a point which cannot fail to be of much moment in influencing the use of light by the profession in localized skin affections. The same arrangement of arc-light mechanisms was adopted by the London Hospital as that of Lortet and Genoud and it is now very widely known as the London Hospital Lamp. More recently the same mechanism has been put upon the market in this country, and is known as the Victor-Finsen lamp, Fig. 19. The manufacturers have been careful not to depart from many of its excellent features but have

neglected to supply a screen for catching the products of combustion and also for the protection of the operator's eyes. It is well constructed and the author has found it satisfactory where the concentrated energy of an electric arc is desired in the more deeply seated pathologic conditions and also well-organized skin conditions. It takes 17 ampères of current and is provided with a suitable resistance which cuts the E. M. F. down to 45 volts. The metal reflector back of the arc is larger than in the original Lortet and Genoud lamps. The manufacturers<sup>1</sup> will in future provide their apparatus with the screen for the protection of the eyes and, also, a second one for the purpose of collecting the particles of burning carbon. The latter is shown in a cut of the Lortet-Genoud Lamp. See Fig. 20. This lamp is provided with especially prepared carbons, in which iron is incorporated into the mass, thereby increasing the intensity of the chemical energy of the high and short frequencies.

Comparison of Finsen's Apparatus and that of Lortet and Genoud.—Finsen's apparatus gives by reason of the high-ampèrage arc used not only the short and high frequencies of intense chemical activity, but also the frequencies of long wave lengths, great amplitude and penetrability, a complex which is essential to secure the best results. With the Lortet and Genoud or Victor, the long wave lengths of great amplitude are not present in such abundance because of the lesser ampèrage and smaller carbons.

The Finsen-Reyn Apparatus.—The Finsen-Reyn apparatus, arranged for the treatment of a single patient, is a 20-ampère, 55-volt carbon arc. The carbons are arranged perpendicularly as in the Finsen apparatus. It differs from the original Finsen, not only by its lesser ampèrage, but by having the water for cooling purposes placed at the proximal end of the tube instead of the distal. Between the arc and the first lens, there is placed a plate of quartz instead of a focal lens as in the Finsen apparatus. The space between these two forms a water cooling chamber, the function

<sup>1</sup>Personal communication.

of which is to prevent undue heating of the first lens with the possibility of injury to the lens. This approach permits the uniting the divergent rays into a more powerful sheaf of parallel rays nearer the patient, i.e., at the first focal lens. In this way an arc of 20 ampères at 55 volts is almost equal to that of Finsen (in the test) 70 ampères and 50 volts. The advantage of the latter, however, lies in the larger carbons used with a higher ampèrage, for by them the unit of area of light is greater and hence 4 concentrators can be used with the one source of energy and 4 patients treated at once. In this country the best lupus or skin lamp is unquestionably the Lortet and Genoud or Victor lamp. If supplied with condensing lenses instead of plates it would be more effective.

The Apparatus of Bellini.—Bellini,<sup>1</sup> in describing his own apparatus, states that when subjected to the same test as the others, the result was the same as with Finsen's. It was used with a 20-ampère, 55-volt arc. He uses a dioptric apparatus in the form of a truncated cone, in the centre of the major base of which is placed by means of a screw a ring holding 2 plano-convex lenses of quartz, with the convexities joined end to end. In the middle of the minor or smaller end of the truncated cone a plate of quartz is placed which serves as a compressor. This truncated cone is filled with distilled water still further cooled by a coil of potable water. The ring at the major base is almost completely immersed in the distilled water. It is cooled, and consequently the temperature of the first lens facing the arc, while to that is communicated the coolness of the convexity of the second lens, which has a plane face in contact with the distilled water. In this way the arc can be used at a distance of 3 cm. without danger of cracking or injuring the lens by heat. By the 2 plano-convex lenses of quartz with convexities facing each other, the use of a disc of quartz to gather up the parallel rays is obviated. Bellini shows by algebraic formula

<sup>1</sup>A visit to the Phototherapeutic Institute, Finsen, of Copenhagen, by Dr. Angelo Bellini, of Milan, *Revue Internationale d'Électrothérapie et Radiothérapie*, Nov., 1903.

that the first lens of the Finsen-Reyn is not correctly placed, but that the anterior disc of quartz ought to be placed at nearly 4 cm. from the arc, as the quartz disc and the water take about 3 cm., and the correct focal distance his equation shows to be 7 cm.

Marine Searchlight Mechanisms.—Marine searchlight mechanisms of from 20 to 80 ampères, provided with large reflecting mirrors of the Mangin type, projecting the beam upon the patient's body at a distance of from 7 to 15 feet, according to the light intensity, are used to a considerable extent in the United States. The author has had in use for the past 4 or 5 years such a 25-ampère marine searchlight capable when adjusted on a short focus, of picking up and observing the manœuvres of a vessel at a distance of one and one-fourth miles. The term focus in this instance refers to the position of the crater of the arc in relation to the mirror.

Fig. 21 shows a cut of the apparatus with the glass door which closes the drum, when used as a searchlight, open. The arc which is enclosed in this drum of sheet iron, mounted in brass or nickel, has a 12-inch Mangin mirror projector, concavo-convex, at the back of it, by means of which a much more powerful light is secured than would otherwise be obtained. The lamp is of the automatic focusing type. The door is left open during all therapeutic applications in order that the short and high frequencies or most intense chemical energy need not be lost by filtering through the glass.

For general application where large square-inch surfaces are involved, as the chest in pulmonary tuberculosis, for example, the arc should be adjusted on short focus, i.e., with the crater of the arc  $5\frac{1}{2}$  inches from the concavity of the mirror. The beam of parallel rays, at from 10 to 15 feet, is 12 inches in diameter, and can be projected at will on any part of the body. The light mechanism is secured to a cast-iron base, and by means of a swivel joint can be rotated in any direction required. By means of another swivel joint the mechanism can be raised or lowered at will, so that the

beam may be directed to any level of the body indicated by the pathological conditions.<sup>1</sup> This mechanism is to be had mounted on a sufficiently high standard of its own. See Fig. 22, or a lower one, as is shown in Fig. 21. In the latter instance it is necessary to place it upon a low table or stool. Application may be from 15 to 20, 30, 45, or even 60 minutes in length. It is the exception that the longer exposure is necessary. In an acute bronchial cold, with dyspnoea, constriction, dry and painful cough, a 20-minute exposure established free respiration, markedly diminished pain and general sense of relief, which persisted, and was promptly followed by loosened cough and free expectoration. Such an application causes considerable redness of the skin, as nothing is used to absorb the heat, and all the frequencies are active.

Screens of Blue Glass.—To eliminate the long and low frequency rays, a screen of blue glass, shown in Fig. 21, can be placed between the patient and the light. In this way the thermal effect is minimized to such an extent that a prolonged application can be borne for any period of time desired.

The use of the screen, however, cuts off the ultra-violet frequencies, thereby diminishing the intensity of the chemical action. Still, therapeutic results seem to warrant the conclusion that the diminution is not sufficient to interfere with results in general conditions.

The writer prefers the entire radiant energy of the arc, and never interposes the screen save where there is undue sensitiveness to the sensation of heat. Even in very nervous patients the action, as a rule, of an expenditure of this radiant energy is extremely quieting and beneficial.

Funnel-Shaped Adjustment of Marine Searchlight, for Purposes of Localization.—The author found, after an experience of several years with a Finsen tube, operated in connection with an 80-ampère arc, that it was too expensive

---

<sup>1</sup>Where an application to the entire body is desired the writer prefers the cabinet heretofore described. See Chap. IX.





Fig. 21.—Marine Searchlight, with Blue Glass Screen.

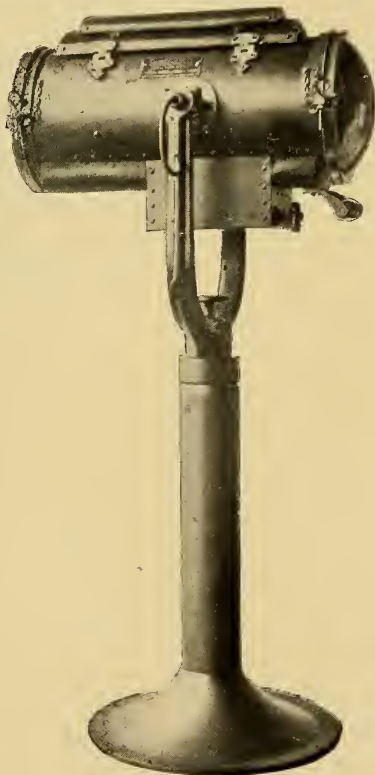

Fig. 22.—Marine Searchlight on High Stand.



to operate and required too much time for a busy office hour, not devoted especially to skin conditions. It was, therefore, laid aside, and as a result of a good deal of experimental work with various forms of electric arc light apparatus, the author with the assistance of the manufacturer of marine searchlights, succeeded in arranging the marine searchlight which was in use for general applications in a very simple and inexpensive manner for skin localization. While the highest chemical activity of the energy of the arc cannot be obtained from carbons horizontally placed, this simple arrangement has given very great satisfaction.

By changing the focus of the lamp from a short to a long one, i.e., from  $5\frac{1}{2}$  to 6 or  $6\frac{1}{2}$  inches, and by the funnel-shaped lid, made of black Russia iron, or copper, preferably blackened on its inner surface, the greatest energy of the beam is secured at a distance just outside the opening of the funnel, or not to exceed 12 inches from the distal end, according to the adjustment of the carbons as they are diminished in length by use. See Fig. 23. This is the focal spot. The arrangement of the focus brings the beam down to a diameter of one and one-half inches, and the funnel of black iron absorbs the heat rays as they impinge upon its sides, while the residual beam of the greatest activity of the arc possible with a horizontal adjustment of the carbons is projected from the opening upon or into the part to be treated. To such an extent is the heat absorbed that the beam can be projected upon the area of diseased tissue just outside the end of the funnel save for the intervening compression of quartz, or at will at a distance or from 1 to 12 inches, without the intervention of any filtering or cooling device. In the treatment of unbroken skin conditions, lupus vulgaris and erythematosis, and in the nodules of recurrent carcinomas, a small block of ice may be secured to the skin surface if desired. This will render the part anæmic, both by pressure and by cold, and will at the same time serve as a heat filter without interfering with the effective energy of the arc. In a chronic eczema of the lobes of the ears, a 20-

minute exposure through a compressing lens of quartz at a distance of 6 inches from the distal end of the funnel from a carbon arc, was readily borne. When iron and carbon is used, the heat is minimized to such an extent that in both mucous membranes and skin contacts there is no sensation of heat at all. The resulting beam, however, is not so deeply penetrative as the pure carbon arc alone. There is no intervention of lenses for cooling or other purposes, and the rays that proceed in a straight line are reflected without passing through the Mangin mirror at the back of the drum, while only those that proceed at an angle pass through the mirror before they are reflected. As the rays passing in straight lines represent the greatest energy it follows that the mirror interferes but little with the value of the light activities.

With this special adjustment of the marine searchlight it is then possible to use the beam of light for actual skin contact, with the intervention only of a compressor of quartz, or a slab of pure rock salt when the positive or iron-cored carbon is fresh.

The Heat When the Arc is Freshly Trimmed Due to the Resistance of New Carbons.—From the first burning of a fresh negative carbon, however, even when the positive is iron-cored, there is given off an intense heat, but as soon as the resistance of the new carbon is overcome there is a steady arc, and the beam of light passing through the opening of the funnel-shaped attachment is so far devoid of heat as to permit of its use as stated, in skin contact, or in mucous membrane contact—mouth, nose and vagina as well. When both positive and negative contacts are iron-cored, the resulting beam of light is even richer in intense chemical energy than the previous arrangement, and burns from the first at a lower temperature, and can, therefore, be used without waiting to overcome the resistance due to the first burning of the carbons. With this arc light mechanism the author has a second funnel of copper to which a brass water-containing cylinder, enclosed at its two ends by means of focal lenses of

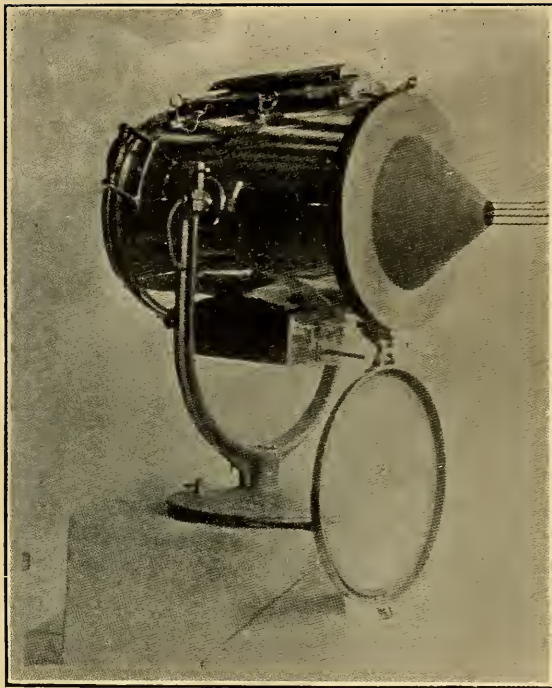

Fig. 23.—Marine Searchlight, with Funnel-shaped Attachment.



quartz is permanently secured. This is used when the lamp is freshly trimmed for the purpose of absorbing the heat due to overcoming the resistance of fresh carbons. The Mangin mirror, as stated, serves to project the beam in parallel rays. Then by the action of the quartz lenses enclosing the water chamber these parallel rays converge on the part to be treated. Where the maximum effect of the effective energy of the arc is desired, however, the funnel alone is preferred, as there is a slight loss of ultra-violet energy in passing through the water.

By this simple device a single mechanism can be made to answer for general and local applications, and for the latter without the use of condensing lenses, or cooling devices. To recapitulate: In mucous membrane contacts no sense of heat is experienced; in skin contacts none at the maximum distance, 12 inches, and but little at 6 inches, or on contact. These various distances are mentioned because in a variety of clinical work skin and mucous membranes (vaginal) they have been found practical.

This detailed description is presented because unity and simplicity of mechanism are greatly to be desired in light therapy.

By substituting a hand feed for the automatic feed, it is possible to have this apparatus constructed with the carbons at an angle of  $90^{\circ}$ . In this way the full energy of the arc can be utilized very near its source, affording the operator a very effective mechanism. The protection afforded the eyes of both operator and patient by the enclosing drum is very grateful. These mechanisms are arranged for both the continuous and alternating current, can be had of different ampèrages and are provided with suitable rheostats for cutting down the voltage.

Apparatus of Dr. Schall.—In England a similar apparatus is in use save that the carbons are placed at right angles and a third carbon is introduced to establish the arc. The reflector consists of some fine clay into whose mass some oxid of magnesium is incorporated. This withstands very

readily the intense heat of the arc. This is also constructed for use on either continuous or alternating-current mains. It is known as the apparatus of Dr. Schall.

Dr. G. Kaiser, whose experiments are quoted in Chapter XIV., also uses a powerful marine searchlight, filtering the light energy through a blue glass screen, as is done in the apparatus used by the author.

Actinolyte.—An arrangement of a focusing arc carrying from 30 to 50 ampères of current, with 2 plano-convex lenses of glass, 8 inches in diameter, supplemented at will by a double convex glass lens of from 6 to 8 inches in diameter, is also in use and is known as the Actinolyte. With this arrangement the beam of from 6 to 10 inches in diameter is projected upon the part of the body in which a localization is desired; for example, the chest walls in tuberculosis pulmonalis. Here, however, all the precious ultra-violet frequencies are lost by reason of the plano-convex lenses of glass and mechanisms arranged in this way are not considered desirable at all. The beam from them is very hot despite the circulation of water. The apparatus is therefore not recommended as at present constructed.

Tests of Apparatus at the Finsen Light Institute.—Different forms of apparatus were tested at the Finsen Light Institute in an original way. A number of rabbits' ears superimposed, behind which was a piece of photographic paper, were submitted to the instrument in turn. The following results were obtained:

Number of Rabbits' Ears.	Apparatus of Finsen.	Apparatus of Finsen-Reyn.	Apparatus of Lortet-Genoud.	Apparatus of Bang.
	70 Amp. 50 Volts	20 Amp. 55 Volts	15 Amp 50 Volts	8 Amp. 35 Volts
1	" 1 sec. +	" 1 sec. +	" 1 sec. +	1 min. - 1¼ min. +
2	5 sec. - 6 sec. +	6 sec. - 7 sec. +	20 sec. - 25 sec. +	5 min. - " +
3	20 sec. - 23 sec. +	20 sec. - 22 sec. +	4 min. - 5 min. +	" - " +
4	2 min. - 2½ min. +	2½ min. - " +	" - " +	" - " +

The + sign signifies the shortest time necessary for an action to be produced upon the photographic paper through the ears of the rabbits.



An analysis of this table shows that the light of the Finsen, Finsen-Reyn and Lortet-Genoud apparatus traversed the one ear in the same time. This illustrates that the value of these different ampères and arrangement of arc-light mechanisms is equal for the more refrangible rays which are absorbed by the first layers of the skin. The Bang lamp, an iron electrode lamp from which the water-cooled iron electrode lamp shown in this chapter is modelled, required very much longer. This means that iron electrode arc lamps rich in ultra-violet as they are, have very few of the penetrating blue-violet frequencies. From their use profound erythema and blistering of the skin results, but the action is superficial.

With two rabbits' ears superimposed, the superiority of the Finsen apparatus is clearly shown, the Finsen-Reyn being a close second, the Lortet-Genoud lagging behind, while the Bang lamp made no impression at all as it does not emit penetrant frequencies. With three rabbits' ears superimposed the Finsen-Reyn apparatus leads, the Finsen is second, the Lortet-Genoud requires 5 min. as against the 22 sec. of the Finsen-Reyn and 23 of the Finsen, while the Bang lamp is frankly unequal to the task. With four rabbits' ears superimposed, the Finsen apparatus clearly demonstrates its superiority over all the others. By reason of the ampère and the larger carbons required, there is a larger unit of area than with the arcs of lesser ampère and smaller carbons. This means a greater quantity of the penetrant frequencies and demonstrates most clearly the need of arcs of high ampère for deep-seated processes. It also shows the futility of attempting to treat them by means of iron electrode lamps.

Iron Electrode Lamps.—A great deal of experimentation on the part of those using light energy has been made in order to secure arcs giving the maximum of chemical activity. This has been based upon the idea that the ultra-violet are the frequencies most active therapeutically. Many different substances have been used for electrodes instead of carbon, for example, metals and substances not readily fusi-

ble, as lime, silicic acid, zircon, thorium and magnesium compounds.

Finsen tried filling the positive carbon, first hollowed out, with a mixture of graphite and calcined lime. As pure metals in the process of volatilization are apt to melt and drip, forming a bridge between the electrodes, which extinguishes the light, it was necessary to devise some means of cooling them. To this end Dr. Sophus Bang, Finsen's assistant, devised a water-cooled iron electrode lamp. A lamp modelled upon this is manufactured in this country. This difficulty is also met in an iron arc, modelled after one of French make, by permitting a free circulation of air about the arc, a description of which will be found upon a subsequent page.

Iron Electrode Lamp.—The lamp shown in Fig. 24 is modelled after the one devised by Dr. Sophus Bang, Finsen's assistant, and is a good representative of water-cooled iron electrode lamps. It is of value in the treatment of the more superficial skin conditions. It is easy to handle. The electrodes are kept cool by the constant circulation of water and the beam of white light is absolutely cold. It is provided with a simple quartz plate, which permits the passage of the ultra-violet frequencies and at the same time serves as a compressor. It is operated on the direct-current circuit of 110 volts and is provided with a suitable resistance.

In England there is a lamp much in use constructed on the same principle as the Bang lamp, known as the "Dermo."

It is good in the same class of cases as the iron electrode lamp mentioned above, but where very great penetration is desired, lamps of greater ampèrage, and with carbon electrodes are to be preferred. But the advantage is not one of metal only. It relates as well to the size of the electrodes. The iron electrode lamps are always small, and contacts likewise, the result is an arc of limited unit of area, and as the amount of light depends upon the unit of area, it follows that the emission of light is less than with carbon contacts, which, by reason of their size, give a larger unit of area. The iron

arc is also a light deficient in the maximum quantity of penetrant frequencies, blue, indigo and violet, although extremely rich in ultra-violet frequencies. Great care should be taken to keep the quartz plates or lenses of these iron electrode lamps absolutely free from dust or from dirt of any sort, as the perfect transmission of the ultra-violet frequen-

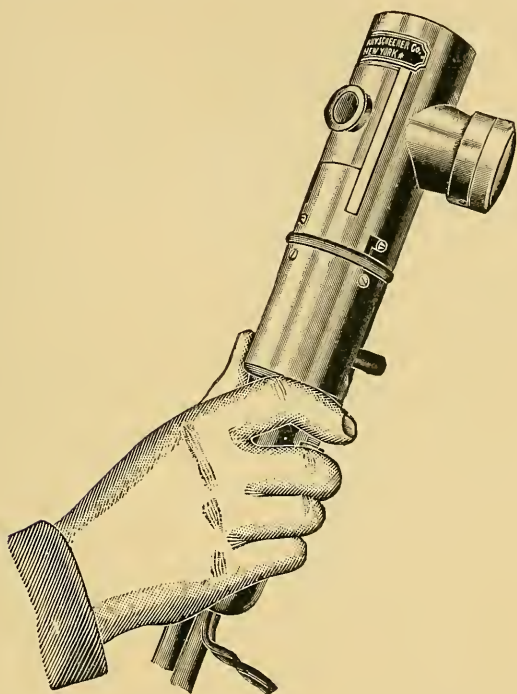

Fig. 24.

cies, the bearers of the precious chemical energy, is otherwise impossible.

Iron Volatilizes at a Lower Temperature than Carbon.— During the burning of the carbons the iron is volatilized at a lower temperature than the carbon, and from its vapor is supplied the extreme of the invisible chemical frequencies of light. By reason of the fact that it volatilizes at lower tem-

perature, the thermal frequencies are not so intense nor abundant as with carbons alone. It is well to have at command an assortment of contacts, pure carbon, and a composite contact in which the iron is thoroughly incorporated into the mass of carbon before it is subjected to the pressure of the moulding process.

When the iron is thus incorporated into the mass of carbon the entire unit of area of light is rich in the extreme chemical frequencies as well as in the longer and more penetrating frequencies. The beam of light thus produced is especially valuable for an application at a distance in the treatment of large areas, where a general or systemic effect is desired. For a localization these iron-cored carbons are equally satisfactory, because of the intense chemical activity in the centre of the crater where the iron core is volatilized. For great penetration, however, it must always be borne in mind that carbon arcs are to be preferred.

The Piffard Lamp.—Recently Piffard has modified a lamp of French<sup>1</sup> make. It has the general outward form shown in Fig. 25. This belongs to the same class as the iron arc of Sophus Bang. The electrodes are of iron and solid and by the free ventilation of air about the arc the circulation of water is dispensed with. One of the electrodes is fixed, to which the positive terminal of the source E. M. F. should be connected preferably; the other is movable and by means of an adjustable spring is maintained at a proper distance to form the arc. By a suitable resistance in series the lamp may be attached to any outlet with a commercial 110-volt direct-current circuit.

The fuse wire connected to the outlet on the wall should be capable of carrying at least 6 ampères. The conducting cords with the rheostat in series are furnished at one end with an attaching plug and at the other with sockets for connecting the lamp. The cord should be insulated with asbestos, and not with rubber or guttapercha. When the

---

<sup>1</sup>Archives d'Électricité Médical, March 15, 1902.

lamp is to be used it should first be connected with the cords, and the cords afterward connected with the desired part of the house service. The current should then be turned on at the socket. To produce the arc,—the push button on the handle is moved forward until the terminals are in contact, and then brought gently back to permit the arc to form.

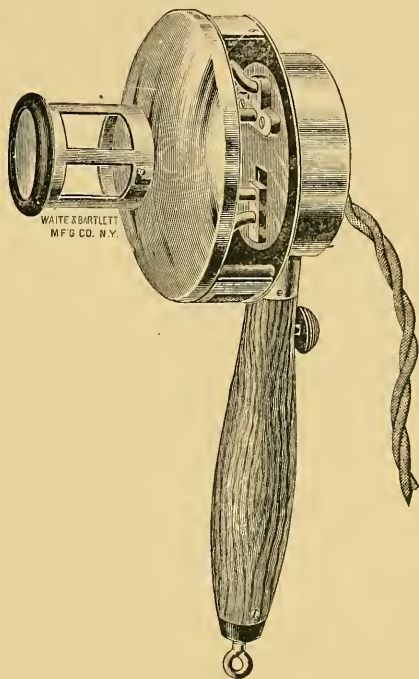

Fig. 25.

The arc may be broken at any moment by simply blowing it out, as one would blow out a candle, and this should always be done before turning off the current at the wall socket. The tube that projects from the front of the lamp carries a quartz plate and is left open on the sides purposely to permit a free circulation of air. The lamp may be furnished in addition with a quartz lens which, mounted in a suitable adapter, will furnish it with either parallel or converging

rays. The strong chemically active light escaping from the sides of the tube naturally impinges on and affects the neighboring parts unless they are properly protected. This may readily be accomplished by means of shields of non-actinic paper. These should be about  $3\frac{1}{2}$  inches in diameter with a central aperture of  $1\frac{1}{2}$  inches. They may be slipped over the tube before it is attached to the front of the lamp. Should the skin lesion be quite small a suitable diaphragm may be made out of the small disc that is cut from the centre of a larger one. The entire outfit, including the rheostat, weighs about 8 pounds, and may, therefore, be easily carried to the clinic or to the house of the patient if necessary. The author has found, however, that practically this arrangement does not prevent heating. In from 3 to 5 minutes application the heat becomes so intense as to be complained of bitterly by the patient. The iron electrode lamp, modelled after Bang's, can be kept cool, but offers the objection due to the circulation of water. Both, however, are capable of doing good work in the conditions in which iron electrode lamps are indicated.

Freund<sup>1</sup> describes the lamp of Reiniger, Gebbert and Schall, which he regards as an improvement upon Bang's lamp. It is an iron arc light, but 2 arc lights are used, one behind the other. This not only increases greatly the illuminating power of the apparatus, but also works the lamps much more economically, for almost the entire total energy of the 110 volts pressure is converted into 2 light arcs of 45 volts each, whilst in lamps with only one arc of 45 volts, more than half of the energy used is expended to no purpose in overcoming the resistance. By reason of the greater intensity of light thus produced, the duration of the exposures to it are diminished.

Lamps with "electrolyte electrodes" have also been described. These are made of oxides of the metallic earths. They must be heated in order to become conductive, and

---

<sup>1</sup>Freund Radiotherapy.

this is done by means of an auxiliary carbon arc arranged close to the others. According to the inventor, E. Rasch,<sup>1</sup> this is said to give a pure white light, which is more efficacious than any other arc light.

Bremer<sup>2</sup> has constructed a lamp, the electrodes of which contain a mixture of carbon and fluorspar, which it is not necessary to heat. They are not placed one above the other, as is ordinarily done, but are arranged side by side at an angle with each other; the arc of light directed horizontally between the carbon points is turned downwards by the current, so that it spreads out like a fan. The light from this arc looks yellow and is also highly efficacious.

Vedding's<sup>3</sup> experiments with 2 Bremer continuous-current lamps, of 12 and 60 ampères at 44 and 60 volts pressure respectively, the positive carbons of which were made of a calcium compound, show that the smaller lamp had a maximum illuminating power of 6,400 candles, that the illuminating power was constant below the angles of 45 to 90 to the horizontal, and only then decreased toward the horizontal to 1,000 candles. The second powerful arc lamp had 4 arc lights arranged on the occasion of the measurement in 2 rows. This lamp gave its maximum of 83,000 below 37°. The experiment showed further that with this new lamp 3 times as much light was obtained as in other arc lamps with the same expenditure of energy. It showed advantages over the older systems, even when alternating currents were used. A considerable part no doubt is played in both Rasch's and Bremer's lamps by the gaseous metal compounds glowing in the arc.

Freund concludes that the noxious vapors given by these lamps may probably stand in the way of their being used for therapeutic purposes.

In this connection the following investigation of the subject is of interest, showing as it does how these metallic

---

<sup>1</sup>Elektrotechn. Zeitschr. Feb. 14, 1901.

<sup>2</sup>Elektrotechn. April 4, 1901.

<sup>3</sup>Ibid. 1900, Part 27. Quoted by Freund.

earths can be used so as to have an increased amount of ozone generated, minimizing thereby the other and objectionable gases.

The electrodes are formed in various ways, the simplest form being a thin carbon tube with or without a coating of tin-foil, magnesia, etc. Barium, strontium, thorium, zirconium and the like are well known as light-emitting as well as oxygen-yielding, and those are selected which correspond to the character of the substances employed in the outer casing. The super-oxids of sodium, calcium, barium, and the like are preferable, as they color the flame. Saltpeter, chlorate of potash, calcium plumbate and the like may be used. The oxygen evolved is immediately ozonized and initiates chemical conversion, and also association processes in the arc by its action on the alkali and carbon vapor; the action being accompanied by considerable heat. The consequence is an intense movement of the ions and a uniformly increased temperature in the arc, and an increased vaporization of the carbon and substances, such as lime, alumina, oxids of barium, sodium or potassium, carbonate of strontium or similar substances. Thus a larger quantity of such gases or vapor is concentrated in the arc, giving increased light and more intense radiation.

The Function of Iron Electrode Lamps.—Before leaving the subject of mechanisms the author wishes to emphasize the fact that the function of iron electrode lamps is limited. With an iron electrode lamp of 25 ampères Bang killed in a few seconds a surface culture of staphylococcus, with a lamp of the ordinary carbon arc, the same number of minutes is required. With such an iron electrode lamp at 1 mm. distance from the face an erythema can be produced in 2 minutes. The iron electrode lamp is very rich in ultra-violet frequencies, but they are very readily absorbed by the majority of media. The light energy from a carbon arc has a power of penetration sensibly greater, estimated by Bang as three times as great as that of the iron arc of the same ampère. The action from the carbon arc is more profound.



The iron electrode lamp produces intense reaction at once and from short exposures, but is superficial. The contrary is true of a carbon arc. Each has its own indication, and while their field of usefulness may touch at points the iron arc can in no sense take the place of the carbon arc. A combination is often effectual.

Carbon Spectra Similar to Sunlight.—For the production of a complex of the entire spectrum similar to sunlight but richer in ultra-violet energy, carbon electrodes of the purest and best make are indicated. For the entire range of skin pathology, as well as for all the uses to which the concentrated energy of the arc can be put, carbon arcs of from 25 ampères upwards are to be preferred to iron arcs. When the light is not only concentrated but condensed by means of focal lenses the energy is increased.

Summary.—For superficial effects, the iron electrode lamp as first devised by Bang, for penetration, powerful carbon arcs with condensing lenses of quartz. Bang states that the Finsen apparatus has maintained its supremacy unrivalled in the treatment of deep-seated affections, such as lupus vulgaris. Good results have been obtained with the iron electrode lamp, even in some cases of lupus vulgaris. Kromeyer, Liese, Below, Kattenbracker and Schiff claim to have had good results with the Kjeldsen lamp (an iron electrode lamp) in lupus vulgaris and erythematosus, alopecia areata, eczema, syphilitic ulcers, condylomata, favus and ulcerating hemorrhoids.

Necessity for Absolute Cleanliness of Plates and Lenses of Quartz, of Mirrors, and in Water-cooled Apparatus of Pure Water.—In order to get a powerful light, whatever the mechanism used, it is imperative that the greatest care should be taken that (1) the lenses or plates of quartz, especially the bottom one, are clean and bright. If mirrors are used, the same care should be taken of them. The brighter and more highly polished their surface, the more effective the light energy. (2) The water must be clear and free from floating particles. It should be changed every day. Where the

water is required for a water chamber, as in the Finsen tube, distilled water should be used preferably because of its freedom from impurities. If, however, water is required for circulation, either about a water cylinder, as is also the case in the Finsen tube, or between the two enclosing quartz plates, or as in the Victor lamp, ordinary tap water will answer, but it should be changed daily.

### **Methods of Use of the Concentrated Energy of the Electric Arc.**

To insure success in the use of light energy, as in connection with the use of every therapeutic agent, there are certain important practical points to be considered. Failures are often due to faulty methods as well as insufficient sources of light. First, the source of light selected, if it is desired to cover the entire range of skin pathology, as well as all conditions in which concentrated light is useful as pointed out under therapeutic indications, must not only be rich in those frequencies which are intensely active chemically, but must also give a quantity of light. To this end an electric arc of from 25 to 80 ampères should be selected. If a minor field of action is desired, that is, more recent and superficial conditions, whether skin lesions, septic processes, contusions, etc., a source of light energy of less quantity and more ultra-violet frequencies may be used, as, for example, an iron electrode arc. To meet the same indications, but with a lessening of the field of usefulness, rather than an increase of it, a spark light is indicated. See Chapter XVI.

Need of Compression to Render the Tissues Anæmic.—The physical inability of the short and high frequencies of light energy to penetrate to sufficient depth, to influence well-organized pathological processes, whether a lupus nodule, scar tissue, a deeply seated inflammatory exudate, or a beginning degenerative change in the spinal cord, necessitates the production of an artificial and temporary anæmia of the part to be treated.

Methods for the Production of Anæmia.—In order to render the tissues anæmic, to which the light energy is to be applied, it is necessary either to use (1) a mechanical means, or (2) a suitable chemical agent.

Compression by Quartz or Rock Crystal.—Under the first head come compressors of quartz as practised by Finsen. If the quartz compressor is a lens it should be used at the focal point of light (or a little in front of it to avoid heating), as that is the place of greatest energy. It is because of the fact that the focal spot is the point of greatest energy that Finsen uses focal lenses or condensers in his apparatus. When a Finsen tube or an apparatus constructed on similar principles is used, it is not only the concentrated energy of the light which is being used, but condensed light as well. In focal light mechanisms, accuracy of focus is of the first importance. The area treated is, as a rule, kept well within the focus of the light, but a smaller focus, if it can be borne, has a greater effect. But few of the light mechanisms other than Finsen's in practical use are provided with focal lenses. Instead plates or discs of quartz are used as in the Victor lamp (Lortet and Genoud). The advantages of condensation, as with the focal lenses of the Finsen apparatus are very admirably met in this lamp, and a larger area can be treated at a single sitting than where the light beam passes through a focal lens. But it has not the penetrative power of the Finsen apparatus. If a focusing light mechanism is used, as the marine searchlight, the compressing plate of quartz should be used at the focal point or, as before, a little in front of it, in order to avoid undue heating.

In such a mechanism, the position of this focal spot will depend upon the fixed position of the carbons or electrodes as well as upon the adjustment of the carriage containing the carbon holders by means of the mechanism for that purpose. These may be so adjusted as to secure the focal spot of light from the particular mechanism at a very short distance from the arc, or they may be so arranged as to focalize

the beam of light at a distance of 10 or 12 feet. With this distant focus there is a loss in the highest chemical activity or ultra-violet frequencies, still willemite will fluoresce all along the track of the shaft of light for a distance of 12 feet, the greatest distance tested, showing that all the ultra-violet frequencies are not lost.

Compression by Means of Ice.—Ice is also transparent to ultra-violet frequencies and is an extremely good agent to sift out the thermal rates or wave lengths. Especially is this true in the intra-vaginal use of light in malignant as well as other conditions. It is a simple matter to fill the cylindrical glass spectrum with pieces of cracked ice. Ice may also be used on skin surfaces and its field of usefulness is twofold, in that the parts, when used externally, are rendered anæmic both by pressure and by the action of cold upon the circulation or as summed up by Walsham.<sup>1</sup> (1) It is hard enough to cause efficient pressure. (2) It adds to this effect by increasing the anæmia by cold. (3) By its transparency it allows the individual lupus nodule to be clearly seen and (4) It is transparent to the violet and ultra-violet rays and opaque to the red and infra-violet.

Compression by Pure Rock Salt.—Rock salt is likewise transparent to the ultra-violet rays, and makes a very efficient and cheap compressor. It can be cut in slabs of varying square inch area, and is applicable to the treatment of small or large diseased surfaces. It is capable of assuming a good degree of polish and can be cleaned by wiping off the surface with pure alcohol. As it permits the passage of all the frequencies, thermal as well, it is not so good as quartz or even ice, but it may be used. Marie<sup>2</sup> uses a compressor to which is secured 4 elastic bands, which, by the intermediary of pulleys, are in turn fastened to the 4 corners of a cushion upon which the head of the patient reclines.

---

<sup>1</sup>Walsham: London Lancet, Feb. 1, 1902. "The ultra-violet light from a rapid oscillation high tension arc for the treatment of skin diseases."

<sup>2</sup>Revue Internationale d'Électrothérapie et Radiothérapie, July and Aug., 1902, Marie.

In this way progressive and energetic compression can be made. A degree of anæsthesia is produced as the pressure is continued, rendering it possible to still further tighten the elastic bands.

Importance of Compression.—This matter of pressure is of great importance, and each individual operator, to be successful, must see that it is firmly, deeply and equably made. The ingenuity of the operator must avail him in the many diverse anatomical localities he is called upon to treat. The object is not to have the active frequencies of light energy absorbed by the blood, and to this end the most complete temporary anæmia is necessary.

The Use of Adrenalin to Render the Tissues Anæmic, Topically and Cataphorically.—The tissue to be treated may also be rendered anæmic by the use of adrenalin. This was first practised by Beurmann.<sup>1</sup> He applied a 1-1000 solution to the part to be treated. In mucous membrane contacts, a piece of absorbent cotton or lint moistened in the adrenalin is applied to the part for from 5 to 10 minutes before using the light. By its characteristic action upon the circulation Freund<sup>2</sup> found from his experiments that it only acts when first applied, i.e., that its effect soon lessens. Both he and Beurmann made a topical application only, however.

In unbroken skin contacts, where there is no contra-indication, a more certain way to secure the desired anæmia from the adrenalin is to introduce it into the circulation by the cataphoric action of the continuous current. Here a piece of blotting paper, or a pad of absorbent cotton of suitable size, according to the area it is desired to deprive of blood, is wet with chlorid of adrenalin, 1-1000 and placed upon the metal electrode or disc, platinum or carbon preferably, although with the small current required block tin may be used. This, in turn, must be connected to the positive terminal of a source of a continuous E. M. F. and placed upon the part while the negative contact is placed so as to

<sup>1</sup>Soc. de dermatolog. et de Syph., July 3, 1902.

<sup>2</sup>Freund, Radiotherapy.

interpose as little resistance as possible to the passage of the current. The negative contact should have sufficient square-inch area to avoid the burning sensation of the current due to too great current density. For example, if the part to be treated is a tuberculous gland of the neck, the indifferent contact, in this instance the negative, is best placed over the upper part of the vertebral column, i.e., including cervical and upper dorsal regions. A contact 2 inches in width by 6 inches in length gives an area of 12 square inches. This distributes the current very well, and permits, if 10 milliamperes are used, but 5-6 of a milliampère to one square inch, which is very readily borne. In using the adrenalin to dehæmatize the tissues about the face as well as neck, the indifferent contact can advantageously be applied in the manner directed. The current is then turned on gradually, until the milliampère metre registers from 5 to 10 milliamperes of current, and is allowed to flow from 3 to 10 minutes. With the maximum current, the minimum time would be required, but with the minimum current the time would have to be increased. Prior to the application, the skin over the part should be carefully washed with warm soap and water, with alcohol or with a bicarbonate of soda solution in order to remove the oil from the skin. This means lessened resistance or increased conductivity, and with the lessened resistance there is not only a much more prompt diffusion of the adrenalin by cataphoresis into the tissues, but there is much less sensory disturbance experienced by the patient. In practice the author uses mechanical means or compressors of quartz, both focal and non-focal, ice and rock salt, for intact skin surfaces. Quartz is preferred, however.

Size and Shape of Compressing Lens and Plates.—The size of the compressing lens, of whatever material made, should vary according to the size of the nodule or diseased area to be treated. Then again the shape of the compressing lens varies according to the contour of the anatomical locality. If for the cheek, which yields readily to pressure, it should be convex, for the forehead concave, and for the

temples plain. It must be held with firm and equable pressure, as is the practice of Finsen.<sup>1</sup>

Figures 26 and 27 show two compressors for use in treating small areas. The one shown in Fig. 26 is especially useful when an application is called for about the angle of

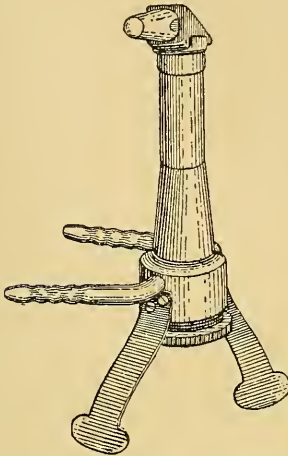

Fig. 26.

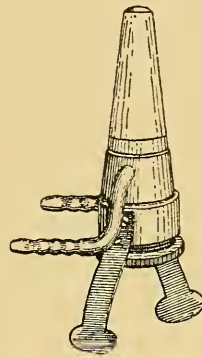

Fig. 27.

the eye and nose. Both are provided with tubes for the inflow and outflow of water.

Length of Exposures with Different Mechanisms. With the original Finsen apparatus the author found it necessary to make exposures from an hour to two hours in length, according to the pathological condition treated.

With apparatus used near the arc itself and without the intervention of cylinders containing water, exposures of from 10 to 20 minutes are necessary. This is true of the Victor-Finsen lamp. With this lamp a 5-minute application will produce an intense erythema, the redness appearing in from 20 minutes to several hours, according to the circulatory conditions of the part. When applied back of the ear directly over the mastoid the erythema appeared in the mini-

<sup>1</sup>Finsen, Schmidt, Berliner klin. Wochenschr., 1901, 32.

imum time, upon the forearm it was much longer in appearing—several hours, in fact. In all cases where it has been used exfoliation has taken place in from 8 to 10 days. The reaction is very marked from an erythema to actual blistering, according to the length of the exposure. With this apparatus 5 minutes should be regarded as the minimum time and 20 as the maximum. In no instance in which it has been used has the author found it necessary to exceed 15 minutes. The same is true of the iron electrode lamps described.

Foveau de Courmelles, Bang and Strebel give the time of exposure necessary with their apparatus at from 10 to 20 minutes.

It is because of the greater chemical light intensity and intense action upon the skin that the shorter exposures suffice. Applications should be made to the most chronic, deep-seated and well-organized conditions daily, selecting different portions of the superficies for exposure on the recurring days. In an extensive lupus growth or epithelioma, for example, two sittings a day may be given in order to promptly bring a considerable area of the diseased tissue under the influence of the light energy.

Frequency of Exposures.—The frequency of subsequent applications will depend upon the amount of reaction and the time consumed in recovery from the same. Complete subsidence of the inflammatory reaction is not to be waited for, as the indication is for the establishment of a hyperæmic process. The same part may need to be irradiated again and again at intervals of a greater or less length of time in obstinate and deep-seated processes. By the action of the light vibrations a stimulus is imparted to the blood stream, increasing its oxygen-carrying capacity; there is an afflux of red blood corpuscles with a corresponding increase of white blood corpuscles, or a leucocytosis. The congestive or inflammatory action thus established, according to the degree to which the physiological irritation produced by the light is carried, results in the death of the diseased cells, and an



increased nutritive activity of normal cells. By successive applications, tissue resistance is increased and healing takes place.

Results Obtained by Frequently Repeated Expenditures of Energy.—In many of the chronic pathological conditions to be treated it is not simply a matter of the amount of a given expenditure of energy at a given moment within the tissues that is necessary to secure the results, but it is its frequent repetition. For example, a man may be easily knocked down and he may pull himself together, recuperate, so to speak, so that it will require as hard a blow or as great an expenditure of energy to knock him down again after a lapse of several days, and with no more lasting results. But, on the other hand, if he is knocked down every 24 hours he has no opportunity for recuperation. In the one instance the work has to be done over each time; in the other, the effect of the previous expenditure of energy (blow) is not lost when the dose is repeated. Therefore, when an expenditure of energy has resulted in a physiological irritation or stimulus of a nature to overcome disease, there is secured by its frequent repetition a steady progress toward the normal, without the slipping back or relapse which is characteristic when this expenditure is infrequent.

In the repetition of light treatment the subsequent reactions are not so severe as the first. A tolerance seems to have been established. This is in part due to the pigmentation of the skin produced by the action of the light. This is a secondary chemical process, and is a protective one. The coloring matter prevents the passage of the light energy.

Necessity for Prolonged Treatment.—Nothing can be more brilliant than the results obtained by Finsen in lupus. Still to secure them means patient and persistent work. For example, the necessary tissue changes can be established which will result in the disappearance of a small lupus nodule the size of a pea, at one sitting from 15 to 20 minutes, when a sufficient intensity of light is used, but this is the exception. Only one small area after another can be treated, and each

has to undergo more or less frequent repetitions of the treatment to secure the desired result. Therefore, the duration of the treatment of a given case is apt to be long. Extensive and long-standing growths will tax the patience of both physician and patient, but the result amply compensates for the time and trouble. To obtain success the requisite medical knowledge does not suffice. In addition there must be an intelligent appreciation of the agent used, and in addition the highest skill and devotion to the work.

Preparation of the Skin for Treatment.—The length of the period over which the treatment extends can in deep-seated lesions of great extent be shortened by following the technique of Finsen, who begins the treatment with the application of a salve containing ichthyol, salicylic acid and pyrogallol, according to the formula of Besnier. By its use, old tubercles become necrotic and by the establishing of this softening and disintegration, the tissues are in much better condition to absorb the light when it is applied. In deeply thickened or hypertrophic areas, a quicker result will be obtained by the use of the pyrogallol ointment. In passing it should be noted that in the treatment of the negro the pigment in their skins is a natural barrier to the easy penetration of the chemical frequencies. Were it otherwise, their ability to live in tropical climates not only without suffering, but in health, would be interfered with. The use of pyrogallic ointment renders the skin smooth and easily penetrable by the light waves, and it should be applied to the part where it is desired to make the application, sufficiently long beforehand to insure this effect. While that spot is being treated by the light, it should be applied to the locality next to be treated in the same way. Morris<sup>1</sup> states that he has used a 5% pyrogallic acid ointment daily for a week, then allowing the part to heal after which the light treatment is resumed. For ulcerated areas or for areas where vesiccation occurs as a result of the treatment, an ointment or salve of either

---

<sup>1</sup>American Medicine, Oct. 19, 1901.

boracic acid or oxid of zinc may be used to protect them. This should be carefully removed by means of a pledget of lint wet in weak solution of peroxid of hydrogen, of mercuric bichlorid or boracic acid before re-applying the light. Any diseased skin surface involving scabs and crusts should be cleansed before each successive treatment, as it is impossible for the light vibrations to penetrate through their thick horny substance. Under such conditions an expenditure of light energy is valueless. For this purpose a cataplasm of boracic acid should be used. The eyes of both patient and operator should be protected from the light by means of colored glasses for the one and bandaging or colored glasses for the other.

Too great emphasis cannot be laid upon the necessity of properly preparing the parts for treatment. If exposure to the light energy be made upon an indurated horny pigmented skin without such preparation, as is constantly done by unskilled operators, the truth of the remark made to the author by members of the profession, that Finsen's results are not duplicated by other operators, will be substantiated. This condition of the skin indicated effectually prevents the passage of the active frequencies, and no result is obtained, or but little.

The best results are obtained in cases which have not been operated upon. Scar tissue by reason of its imperfect supply of blood vessels prevents the requisite absorption of the active energy, for the result depends upon the absorption of the frequencies which have been known to possess bactericidal and vaso-dilatory powers. A hyperæmia, more or less lasting, is absolutely necessary to the establishment of a cure, not in lupus only, but in many other skin conditions, alopecia areata, favus, chronic acne with hypertrophied nodular tissue, scar tissue and keloid. The same is true in tubercular glands, joints, tuberculosis of the lungs, syphilitic lesions, inflammatory exudates, etc.

In very deep-seated lupus nodules the duration of treatment may be shortened by first destroying them with the

actual cautery. When the reaction established is very profound, treatment should be discontinued until the period of inflammation, absorption and repair has passed, for only then can it be determined whether further treatment is necessary. During this suspension of treatment, however, the case or cases should be carefully watched, for it sometimes happens that isolated and deep-seated nodules remain in evidence. This cannot always be determined until the evidences of reaction have fully subsided. Then, if necessary, one or more supplementary treatments may be given. In the elephantiasis-like forms of lupus sometimes seen on the ears, cheeks, and elsewhere, the reactions may be so severe that they are badly borne by the patient.

During the progress of the case, the course of treatment may be shortened and time saved for the patient by the use of oxid of zinc ointment. In mucous membrane involvement a solution of iodine and iodid of potassium 75%, lactic acid, or the electro-cautery are variously recommended.

Because of the nature of the disease it is necessary to have the patient under observation for long periods of time in order that a re-application of the light can be made in the event of a relapse. The process of cure is well-organized and deep-seated skin conditions is not a rapid one. It is slow but sure.

Technique of Finsen's Lupus Treatment.<sup>1</sup>—At the Finsen Light Institute each patient has his own attendant, whose business it is to direct the light constantly on the diseased spot. The patient lies on a suitable couch with his head raised, or sits in an armchair with a head rest. The time of the application (sometimes two hours) is too long for a patient to remain immovable. His eyes are protected by a cloth, the attendant's by darkened glasses. Any scabs or crusts are first softened, and then removed with forceps, and the part is washed with a weak antiseptic solution, 3%

---

<sup>1</sup>Finsen's Technique as given by Freund in "Radiotherapy."

boracic acid, and dried. The beam of light is then directed to the disease, and care is taken that the axis of the beam of light is perpendicular to the area illuminated. The part to be treated is not placed directly at the focus, but a little in front of it, so that not one point of it, but a small circle, is illuminated. In this way there is less danger of the skin becoming heated. A circular area having a diameter of 2 cm. may be treated at one sitting. The surrounding parts are covered with wadding or yellow paper. A suitably shaped compressor is placed on the diseased spot, and held there firmly with equable pressure. The shape of these should vary according to the part to be treated, as has been pointed out. The duration of the sitting varies according to the quality and intensity of the light used. Finsen recommends a 2-hours exposure with his concentrator and a lamp of 30 ampères. With lamps of 80 ampères the time may be cut down to an hour and a quarter. With these powerful lamps Finsen found 13 to 20 minutes' illumination to affect a definite cure of lupus nodules the size of peas. The patient suffers no pain during the irradiation except when the pressure is applied to ulcerated or bony parts, for example, near the nose. After the treatment, symptoms of erythema solare appear. The irradiated parts become a little red, the redness very soon increases markedly, and at the same time slight swelling shows itself, and burning pains are felt, the skin becomes softer and unevennesses disappear. Within 24 to 48 hours later a large blister forms, filled with serous fluid. This dries away in 6 to 8 days to small readily removable scabs. There is never any loss of substance below the blister. When the blister is exfoliated considerable redness is left, which only passes away after months. To prevent infection of the blister a dressing is applied of boracic lotion or zinc ointment. After a week or fortnight, when the reaction has disappeared, and the scabs have fallen off, the same place may be irradiated again, later even more than once; in fact, this is necessary if the therapeutic effect is to be lasting. When one spot seems to have been sufficiently

treated the neighboring spot is to be treated in the same manner. In this way the treatment proceeds from spot to spot until the whole part attacked has been exposed to the influence of light. The treatment should begin at the periphery of the lupus region, and the light must be so directed that in each area of illumination a piece of apparently healthy skin in the immediate neighborhood is also included. After the sitting the spot is marked with a pencil, then the dressing is applied.

The compressor having been cleansed with ether, alcohol and a solution of carbolic must be steeped for an hour in carbolic, and then placed on the side filled with distilled water. The rock-crystal lenses of the concentrators are cleaned once or twice a week with ordinary water, and afterward rubbed with cork. Those nearest to the carbon points are further brushed down thoroughly after each sitting, and covered with flannel caps to prevent too rapid cooling and consequent cracking.

Finsen, whose experience in the treatment of lupus by the means of light is far more extensive than that of any other operator, has established the time necessary for lupus cases to be under treatment at from  $4\frac{1}{2}$  to 6 months.

The cosmetic results from the use of light are most satisfactory. There is no destructive action as with chemicals, the cautery or the X ray. On the other hand, there is a constructive action from the beginning, induced by the conservative action of light. There is no untoward action when the apparently healthy tissues around the diseased part are also subjected to the action of the light. Healing takes place without any scar tissue whatever, the scales, thickness, hardness of the long-standing infiltration, characteristics of such chronic skin lesions, lupus erythematosus, vulgaris, acne, etc., disappear, and the skin becomes soft and elastic, with a smooth surface like the rest of the skin. There remains in some conditions a brownish reddish color, from the persistent and long-standing congestion, and due to the diseased process. The reaction established by the

action of the chemical frequencies of light upon the skin is in the milder doses scarcely if at all apparent. With greater condensation and longer applications it becomes more marked, and usually appears the day following the application. Unlike the Roentgen ray, it appears and disappears quickly, and leaves no destruction of tissue or untoward result of any kind. With the former, the period of incubation is everywhere from a week, 10 days and upwards, and the areas acted upon are extremely difficult to heal. From the use of light the reaction established is characterized by the degree of redness more or less profound and swelling. This reaction is from that of a simple congestion to one of inflammation, depending upon the degree of energy of light values used, as well as the time of exposure. There may be considerable œdema. The reaction lasts but 4 or 5 days, when it disappears, leaving the surface of the skin smooth, and of normal characteristics. There remains a little pinkish coloring for a few days longer. The light treatment causes no pain. A red erythematous spot and blister appears where the light is applied, and in 5 or 6 days the scab falls off, and the ulcer is healed beneath, and the skin is left free from scar or cicatrix, but red. The red fades away after a variable period, and leaves the skin white and uncontracted beneath, save where there has been a loss of tissue from the disease before treatment. The difference between the appearance of the skin from the use of the X ray and from the use of the light is very marked. With the former there is a retracting or drawing of the skin due to the atrophic changes established in the skin follicles, sweat glands, oil ducts, and hair follicles. With light there is absolutely no wrinkling of the skin, no atrophic changes, but a perfect smooth white, or pinky white condition. If the treatment has been given to an unbroken lupus nodule, for example, there is absolutely no scar tissue, but if to an ulcerated lupus vulgaris, a syphilitic ulcer, while the cosmetic effect is just as good, and there are no atrophic changes, there is the little pucker or scar due to lost tissue.

Involvement of Mucous Membranes.—Even when the lupus process attacks the orifices of the body, as the mouth, gums, palate, or the nose, this method may still be used but not with as good results as with skin surfaces. Morris<sup>1</sup> and Dore consider involvement of the nostrils, mouth, a contra-indication to the use of the light treatment. According to Forchhammer, the relapses occurring in lupus cases after treatment are generally among those patients who neglect to report at the end of the treatment; or where there is extensive mucous membrane involvement. Any severe intercurrent and debilitating disease, as influenza or erysipelas, may also operate to cause a relapse.

Contra-indication in an Isolated Instance.—In a case treated by Brocq,<sup>2</sup> exposure to the light energy always produced the most violent eczema and œdema, so that it could not be used. This is unusual, for its action is eminently conservative, not only in that it is readily borne, but that it spares healthy cells.

Conditions Influencing Prognosis.—Too great an emphasis cannot be laid upon the fact that scarring, pigmentation, vascularity, great depth below the surface, the situation of the disease near the eye, on the eyelid or on the mucous membranes, as well as great extent of the lesions, are factors which unfavorably influence the prognosis.

But while this is true, it need only be remembered that Finsen is authority for the statement that not more than 2% of lupus cases need be regarded as incurable.

The Choice between the X Ray and Light Energy.—As to the choice between the X ray and light energy in the treatment of lupus, the author believes it lies with light. The X ray possesses drawbacks, in the dermatitis produced by it and the atrophic changes in the skin which sometimes follows its use. It is not the province of this volume to discuss the value of the Roentgen ray in lupus. It has a place of very great value, but wherever the lupus process is one

---

<sup>1</sup>American Medicine, Oct. 19, 1901.

<sup>2</sup>IV. Intern. Cong. de Dermatologie, Paris, 1900.



that can be controlled by the action of light energy, to it should be given the preference. The time required where cure results is perhaps not any less for both light and X ray treatment than with other classic measures, but they are both conservative, the light eminently so. It is practically painless in the average case and insures the best of cosmetic results. The strongest plea for the use of light energy, if plea it needs, is not only that it cures, but it cures safely.

Conclusion: It is not necessary to corroborate Finsen's work in lupus vulgaris by that of any other. It stands unparalleled and needs neither proof nor disproof.

In skin pathology, however, there is a very wide range for the use of the concentrated energy of the electric arc other than lupus vulgaris.

In the following conditions concentrated energy of the electric arc spectrum has been used with considerable degree of success: Lupus erythematosus; chronic acne, vulgaris and rosaceæ; sycosis, paritaria and non-paritaria; superficial epitheliomas; eczema; psoriasis; alopecia areata; favus; syphilitic ulcers; condylomata; nævus vascularis; furunculosis; rhinophyma; biskra-button and septic processes.

The literature of the past few years contains reports of the treatment of these various conditions, with varying degrees of success by different operators.

For eczema, psoriasis, syphilitic ulcers and septic processes, the author, judging from such clinical experience as has been afforded, believes that light energy acts almost as a specific. The results obtained are not only dependent upon the suitability of the source of light energy, but upon the care and skill with which the work is done. The use of this agent is no exception to the universal rule, that everything depends upon the intelligent skill with which it is used.

Vegetable Parasitic Diseases, Ringworm, Favus, Pityriasis Versicolor and Sycosis.—M. Marie reports a case of sycosis involving both cheeks, which healed admirably from a single exposure, of from 10 to 15 minutes' duration, to the

concentrated energy of a 60-volt and 15-ampère arc, in which the carbons were placed at right angles, the negative smaller than the positive and regulated by a hand-fed mechanism. In this way there was secured the light of the *arc* or blue mist, the crater serving as a reflector. The active frequencies were concentrated upon the part to be treated through the media of quartz plates, the patient being placed very near the source of light. Leredde<sup>1</sup> also reports a case of chronic sycosis cured with light and Gerson<sup>2</sup> and Von Ziemssen<sup>3</sup> noted good results in ringworm, favus, sycosis and pityriasis versicolor.

G. M. Müller, Strebel and Barbensi<sup>4</sup> have treated sycosis parasitaria and non-parasitaria by means of light energy.

From the action of the X ray in this disease the inference is drawn by the author that light should be effective. Sufficient data has not been accumulated as yet nor have the results been sufficiently definite and certain to assign to light energy a positive place in the management of sycosis.

Finsen's<sup>5</sup> cases of favus gave negative results and up to 1901 he had reported but two cures, recent cases, in six ringworms of the scalp in children.

Lupus Erythematosus.—Finsen, Bang, Forchhammer, Leredde, Petersen, Sabourand and G. J. Müller have tried treating this condition with the concentrated energy of the electric arc. They have found it to act satisfactorily in fresh cases, but in cases of longer standing and especially if the lupus erythematosus is generalized, it often has no effect.<sup>6</sup> Lesser<sup>7</sup> had less favorable results in the treatment of lupus erythematosus than in lupus vulgaris. They were less cer-

<sup>1</sup>Leredde: Presse Medicale, Sept. 7, 1901.

<sup>2</sup>Gerson: Archiv. für Lichttherapie, Vol. I., No. 3, 1899.

<sup>3</sup>Von Ziemssen: Festschrift zur Feier des 50 Jährigen Bestehens des Ärztlichen Vereins Nürnbergs; Monatshefte für praktische Dermatologie, June 15, 1903.

<sup>4</sup>Quoted by Freund.

<sup>5</sup>Finsen, Niels R.: Mitteilungen, etc., 1899, 1900, 1901. Bie's translation.

<sup>6</sup>Quoted by Freund.

<sup>7</sup>Zeitschrift für Diätetische und Physikalische Therapie, Lesser, Berlin, 1901-1902, Heft 16.

tain. This was also the experience of Petersen<sup>1</sup> and is corroborative of Finsen's experience as well as that of many others. In the author's experience a case of lupus erythematosus involving nose, both cheeks and ears, associated with chronic eczema and with extensive infiltrations of the lobes of the ears, improved to a very marked degree under the influence of the concentrated energy of the arc alone. Complete recovery from the lupus erythematosus, however, did not take place until the parts were exposed to the Roentgen ray for a few times. Leredde<sup>2</sup> reports 3 failures, 3 improved and 11 completely cured out of a total of 23 patients, while 6 more exhibited a "segmentary cure," that is, one patch was cured. To appreciate the value of these results he gives the following résumé of treatments previously inflicted upon these patients: Galvano-cauterizations 802 séances; scarifications, 382 séances; high frequency currents 462 séances. None of them had even a single patch cured by any of these measures. Sometimes the most hopeless cases apparently were the most rapidly cured. Leredde thinks the light treatment should be pushed until the formation of cicatrices. In this connection he states that it is likely to fail in the vegetating elephantiasic type of lupus or where there is deep sclerosis, unless the field can be cleared for the action of light (currettement might avail here) before its use. In lupus of the trunk or limbs healing may take place more rapidly under the use of other measures owing to the existence of a plane of hypodermic cleavage, which generally prevents the progression of the lesion into the depths. Every case of erythematous lupus should receive energetic treatment from the start. Finsen has demonstrated that the longer it lasts the deeper and more rebellious it becomes. Radiotherapy should be tried if concentrated arc light energy fails and in certain regions ablation might be indicated.

---

<sup>1</sup>The Success of Light Treatment, Petersen, *Vratch*, Nov. 10, 1901, Vol. XXII., No. 43.

<sup>2</sup>Leredde: Indications and Contra-indications for Phototherapy. *Journal American Medical Ass.*, June 21, 1902.

During a course of treatment by light all scarifications should be avoided, as the formation of scar tissue is inimical to the penetration of light.

Gaston<sup>1</sup> reports 3 complete cures and several partial cures in 10 cases of lupus erythematosus.

Morris and Doré<sup>2</sup> of 6 cases of lupus erythematosus reported 2 cures, 3 discontinued and one under treatment at the time of the report. Of the successful cases one of 15 years' duration was very extensive and superficial. The areas covered by the disease were after treatment occupied by a fine white scar. In the other the disease was more chronic, less superficial and there was deeper scarring.

Hyde and Montgomery<sup>3</sup> report 9 cases of lupus erythematosus treated long enough and with sufficient regularity to note results and state that they found the treatment of undoubted value. With one exception their results were better from the use of the concentrated energy of the electric arc than from the X ray, though both methods were tried in several cases. The lesions were on the face, nose, eyelids, forehead and ears, and were of from one and one-half to five years' duration. In their work an area one inch in diameter was treated at each sitting of 15 minutes' duration. The intervals between the sittings varied from 5 to 14 days. From 2 to 4 hours after treatment there are some anomalous sensations, such as pricking or stinging. These occur from the use of the light in any condition and are often experienced much earlier and last for a much longer time.

Those lupus erythematosus lesions in which the vascular element predominates yield most readily, some of them disappearing after 2 treatments. On the other hand cases in which the sebaceous element predominates are the most obstinate.

---

<sup>1</sup>A year's experience with phototherapy, Gaston, *ibid.*

<sup>2</sup>The Lane Lectures on the Social Aspects of Dermatology, Malcomb Morris, London, American Medicine, Oct. 19, 1901.

<sup>3</sup>Radiotherapy and Phototherapy, Hyde and Montgomery, *Jour. Am. Med. Ass.*, Jan. 3, 1903.

While the effects in lupus erythematosus are strikingly inferior to those in lupus vulgaris, still they are sufficiently favorable to warrant the use of energetic and prolonged light energy. The justification of this is to be found in Leredde's experience.

Eczema.—This is also a condition which lends itself to the action of light energy. By means of concentrated and condensed arc light energy, a patch of eczema of the axilla was completely cured by one exposure in the author's practice. The use of light energy in eczema has also been considered under Electric Arc Light Baths.

Hellmer<sup>1</sup> reports an extensive pustulo-crustaceous case of 2 months' standing cured with 7 exposures. Good results were obtained by Minim<sup>2</sup> in a case of chronic eczema of the face. In this operator's hand the visible chemical frequencies of concentrated incandescent light were used.

Gerson<sup>3</sup> also reports satisfaction with the results in eczema from the action of light energy.

Finsen has reported but a small percentage of cures in chronic eczema from concentrated and condensed light energy.

Acne Vulgaris.—In the author's practice marked improvement has been obtained in the most extensive and long-standing cases of this sort, cases in which pimples, pustules, nodules, pitting, thickness of the skin and deep infiltration of the tissues were associated. Treatment has been interrupted in this grave class of cases before a complete cure was accomplished. Light energy has served, however, to improve the condition where all other means have failed. The concentrated energy of the electric arc has been used with compression, and also the electric arc bath. Given but the one means to the end the author considers that the choice lies with the general rather than the local administration of

---

<sup>1</sup>Hellmer, Ernst: *Blätter für klinische Hydrotherapie*, No. 7, 1901.

<sup>2</sup>Minim, A. B.: *Medicinische Wochenschrift*, No. 12, 1901.

<sup>3</sup>Gerson, *ibid.*

light as a systemic fault, or vice always lies at the bottom of this facial condition. Finsen reports a small percentage of cures in acne vulgaris from the use of the concentrated energy of his 80-ampère carbon arcs.

Acne Rosacea.—Leredde<sup>1</sup> reports 8 cases. In mild cases he does not believe it best to resort to the use of light energy because of the expense attendant upon it. In longer standing and more deeply infiltrated cases of the disease, he finds that the use of light offers undeniable advantages, when associated with the necessary treatment of the visceral troubles, particularly troubles of the gastro-intestinal tract.

Acne Rosacea of the nose lends itself especially to treatment by light because of the depth to which the diseased process extends. This is not so true where the cheeks are involved. Leredde does not hesitate to employ scarification where chemical methods have failed.

The author has had but little experience in the treatment of acne rosacea by the means of the light energy, but in the improvement obtained in this class of cases from the use of the continuous current, is prepared to believe that much can be accomplished by the use of light. In their deeply penetrating chemical action, the two, i.e., the light energy and the continuous current, are comparable; but the former produces its characteristic action upon the skin and superficial blood vessels, with the best of cosmetic effect; while the latter, when of sufficient intensity to produce the same changes, acts destructively upon the skin, causing scar tissue.

Epithelioma.—There is considerable and reliable data, showing that in superficial epitheliomas, concentrated light energy is of avail, but there are many other classic measures that are undeniably of equal value. Still as a production of scar tissue is to be avoided, whenever and wherever possible, preference should be given to light in this class of cases. In 16 cases of epithelioma of the skin, treated by

---

<sup>1</sup>The Treatment of Rosacea, Leredde, Rev. Prac. des Mal Cutanées, Aug. 1, 1903.

concentrated light energy and reported by Bie,<sup>1</sup> there was in 3 cases no improvement; in 5 cases improvement but not cure; in one after apparent cure speedy recurrence, while in 7 the result was described as a cure, which had been maintained respectively for  $2\frac{1}{2}$  years, 11 months (2 cases),  $9\frac{1}{2}$  months and 6 months (3 cases). From this experience Finsen concluded that the cases of epithelioma, which respond to the action of light energy are, as has been stated, superficial well-defined forms in accessible localities. Distinct improvement has been seen in the treatment of this class of cases by Petersen, Bugesdorf and others. Preference is given very justly to the X ray by all investigators.

In a case of recurrent epithelial nodes upon the nose of a woman, aged 70, in the author's practice the energy of an iron electrode arc sufficed to produce absorption of two-thirds of one of the nodular masses, and all of the other. To secure absorption of the more deeply infiltrated tissue of the remaining third of the larger nodule, the deeply penetrating frequencies of a 25-ampère carbon arc, condensed by the means of focal lenses, sufficed.

*Alopecia Areata.*—This is also a condition which theoretically lends itself to treatment by light energy. It is believed by many dermatologists to be of a parasitic nature, and the condition is one demanding the production and maintenance of a hyperæmia, if good is to follow. The bactericidal action of light, its ability to excite tissue reaction, and the stimulating effect consequent upon the skin inflammation all suggest the applicability of light energy to the treatment of alopecia areata.

In the first report<sup>2</sup> of the work of Finsen in English, published simultaneously in England and America, mention is made of the use of light energy in alopecia, and 7 cases were reported cured. These were first published in Danish, January, 1899.

<sup>1</sup>Malcom Morris, *Social Aspects of Dermatology*, Lane Lectures, American Medicine, Oct. 19, 1901.

<sup>2</sup>Finsen's Phototherapy, Vlademar Bie, *The Philadelphia Medical Journal*, Oct. 7, 1899, and *British Medical Journal*, Sept. 30, 1899.

The following detailed report was made at that time: A patient, aged 15, in the beginning of June, 1897, noticed a bald spot about one cm. in diameter which was steadily increasing. When the treatment was instituted September 3, 1897, there was a large completely bald spot of 6 by 4 cm. The areas immediately surrounding the diseased area were shaved, and afterwards 8 treatments were given of a half an hour each, from September 3 until September 24. On October 4 lanugo hair was noted in the patch. November 5 a normal growth of hair. January 12, 1898, a bald spot  $2\frac{1}{2}$  by 2 cm. was seen. From January 12 to 16, 5 exposures, an hour each in duration, were made. January 22, fine small hairs noted. March 29, the growth of hair is as vigorous as on most of the scalp. On October 22, 7 months later, the condition remained the same.

According to Freund, O. Jersild<sup>1</sup> first suggested the application of light energy to the treatment of alopecia areata. The reports of Jersild were very encouraging. Gottheil<sup>2</sup> mentions 2 cases in which extension of the bald areas stopped and lanugo hairs began to grow within 3 weeks after beginning treatment. In a later report of the work done at the Finsen Institute by Forchhammer, 30 cases out of 49 treated were cured. Sabourand in a personal letter to Freund reported a much less successful experience; in active cases of alopecia areata no good results were obtained by the use of concentrated light energy, but in chronic cases, limited in extent success was met with. The method of application is practically the same as for lupus vulgaris. A powerful source of light energy is necessary, and it should not only be concentrated but condensed by means of focal lenses. Before exposure the parts around the bald spot must be carefully shaven, for from one to 2 cm. The judgment of the individual operator must govern the extent to which this

---

<sup>1</sup>Annals de Dermatologie, 1899, p. 20, quoted by Freund, Radiotherapy and Phototherapy.

<sup>2</sup>Gottheil: Georgia Journal of Medicine and Surgery, June, 1902.



should be done. The first exposure should be made to the periphery of the healthy part in order to prevent further extension of the disease, and to advance toward the centre. From one to two exposures should be made daily according to the condition of the given case, and for an hour and a quarter each. The closeness of the scalp in relation to the skull, renders compression of less importance than when soft tissues are being treated, and Jersild found compression unnecessary. In his practice he kept the skin cool by wetting it with cold water. The author would suggest here the use of a smoothly cut slab of ice. By simply resting on the part the skin would not only be kept cool but anæmic as well, and the light energy at the same time be permitted to pass. There should be no pain attendant upon the treatment. Exposures should be made only once to each diseased spot until the amount of reaction as well as result is known.

The first thing noted as the result of treatment is that the hair stops falling off from the part treated; later lanugo hairs appear (according to Jersild, at the earliest after 11 days) in longer or shorter time on the bald patches which gradually become pigmented and thicker. Lesser<sup>1</sup> also noted favorable results from the use of light energy in alopecia areata.

Theoretically it would seem that the best results should follow the more recent origin of the disease. In cases of many years' standing it simply follows from the nature of the pathology that no good results should obtain; for the longer standing the more complete the destruction of hair follicles. No matter what the pathological condition, whether involving the structure of nerves, glands or hair follicles, degenerative changes fully established are absolutely beyond the expenditure of any form of energy, no matter what its value where the process is not yet complete. Degenerative changes may be arrested in the one instance or the other, but a hair follicle, for example, once destroyed, cannot be restored under any circumstances.

---

<sup>1</sup>Ibid.

Rodent Ulcer.—Morris<sup>1</sup> reported seven cures in thirteen cases of rodent ulcer. Two had been subjected to excision, prior to treatment by light; the X ray was used to finish the treatment in the case with the most extensive involvement, having had 35 exposures of light energy first. Of the remainder 5 recovered in from 7 to 22 exposures; while of a case of small rodent ulcer in a man aged 83, 2 years' duration, inner canthus, right eye was treated for  $7\frac{1}{2}$  hours with success.

In a very extensive rodent ulcer involving loss of the scalp 4 to 6 inches in diameter, and also the skull plates (arsenic paste), the author found an exhibition of light energy a valuable adjuvant to the X ray treatment, in controlling pain, discharge and stimulating granulating tissue. For a time this patient improved, but a year after coming under observation died from exhaustion following a rupture of a blood vessel and consequent hemiplegia.

Nævus Vasculosus.—Light energy seems to recommend itself as of especial value in the treatment of this condition. The process of repair following upon the endo-vasculitis, established by the action of light energy, is a rational explanation of its action. This endo-vasculitis is followed by an obliteration of the vessels themselves, as was established by Sack. Pusey regards it as a better agent than the X ray. The deep red color of the diseased area is reduced by the action of the light in most cases, according to Forchhammer, while in some cases complete cure is established.

It was observed by Peterson in a case in which the nævus extended from the forehead to the eyelid that there was improvement not only in the part of the forehead treated, but also on the part of the upper lid, which because of its relation to the eye was not irradiated. This should be expected for the action on the larger vessels of the forehead would unquestionably influence the contributory area.

Lesser<sup>2</sup> has noted a favorable result from the use of con-

---

<sup>1</sup>Ibid.

<sup>2</sup>Lesser. *ibid.*

centrated arc light energy in telangiectasis. The author should expect good results to accrue from an expenditure of the chemical energy of the arc in cases of *nævus vasculosus simplex* or simple angioma, in the various forms known to the laity as "port-wine stain," "strawberry-mark," or "mother's mark." These occur in smooth, flat, non-elevated or very slightly raised well-defined or faint patches. As they occur in children or even from infancy to adolescence they should yield to the action of light energy. The younger the subject, the better the result should be, for the skin of these young subjects is very soft, smooth, thin and unpigmented, conditions which enable the effective frequencies of the arc to penetrate more readily than later in life, when the skin becomes thickened and pigmented. As the treatment is absolutely painless, it lends itself to the treatment of young children.

In the second variety of *nævus vasculosus*, or angioma *cavernosum*, light energy theoretically does not seem to offer much. Great vascularity is a contra-indication for its successful employment, and this variety of vascular *nævi* is characterized by great vascularity. It occurs as a prominent, turgescient, erectile, or even pulsating tumorous-like growth enlarging during crying or other emotional disturbances. There would be no danger in attempting the treatment of cavernous *nævus* in the manner even though no result is obtained.

In *nævus pigmentosus*, or pigmentary mole, those of smooth surface, slightly elevated above or level with the surrounding skin, might be readily acted upon by the concentrated electric arc energy; the pigmentation would however interfere or modify the penetration of the light energy. In the other varieties of pigmentary moles the author uses the electrolytic method in preference to all others.

Leprosy.—The good effects obtained from the treatment of the superficial lesions of tuberculosis, and the more superficial malignant skin conditions from the use of light are certainly very suggestive of possible benefit from its use in the

treatment of leprosy. As a bacterial disease leprosy has some peculiarities indicating the possible utility of light; it is mainly confined in its manifestations to the parts of the body that can be reached and its microbe, judging from its apparent feeble contagiousness, is not in all respects resistant to hostile influences. Sequeira has observed some action in the lesions of tubercular leprosy, but experience in this particular direction is thus far limited.

As a disease, notably characterized by deficient oxidation, the short and high frequencies of light energy, especially the complex of violet and ultra-violet, are, theoretically at least, indicated. The author suggests that in the event of the opportunity offering leprosy lesions should be so treated.

It is not only in medical cases but in surgical as well that the action of light energy is effective.

In infectious processes it is of great avail and in it there is to be had an agent which is at once bactericidal, antitoxic and resolvent.

Septic Processes.—The opportunity has offered for the use of the concentrated energy of the electric arc in minor septic processes. The following very illustrative case of blood poisoning, due evidently to the bite of an insect on the middle of the dorsal surface of the foot, just over the arch, may be instanced in this connection.

There was systemic infection, as evidenced by chill and fever. The lymphatics from foot to groin were swollen, red, hot, and painful. There was also four to five days later on in the history of the case, an intense localized inflammatory action at the site of the bite, with the characteristic boggy feel of a deep-seated suppurative action, co-existent with the most extensive cellulitis of the entire dorsum of the foot which the author had ever seen. The skin was literally stretched to the fullest extent, presenting a very smooth and glossy appearance. The patient was unwilling to have it laid open when seen at his home, because of the position just under the shoe lacing and the consequent

disability. He was, therefore, placed in a carriage and brought to the author's office, where a single exposure to all the chemical frequencies from the blue into the ultra-violet, of a 25-ampère carbon arc (the special adjustment of the marine searchlight mechanism), was made. The concentrated energy of the arc was used at the focal spot, through a condensing lens of quartz, which served as a compressor, for 15 minutes. At the end of the exposure, the pain, swelling, soreness, and immobility had practically disappeared.

A subsequent application was made on the following day, as a matter of precaution, although the patient stated that his foot was "perfectly all right." He had on this second visit only accompanied his wife, who was under care, to the office.

The tissues under the compressor remained analgesic and indurated for several days, but both of these conditions disappeared. A single localized application of the convective discharge of the franklinic current hastened absorption. There was no further trouble, and the troublesome open sore with the formation of scar tissue was avoided.

Similar satisfactory results have followed the use of concentrated arc light energy in septic processes originating at the site of hair follicles in a case of carbuncle and involving the subcutaneous cellular tissue. The carbuncle had been opened and the arm and hand exposed to the action of the X ray prior to the patient, a physician, coming under observation. He had been ill for from two to three months when he came under the author's care. The original lesion had healed, but constantly successive crops of pustules appeared, apparently superficial but in reality very deep-seated. Each one had to be opened before healing could be established and each in turn was followed by another and another, all going on to the suppurative stage. The arm and hand had subsequent to the X ray been treated by means of hot air but without relief. The patient was thin, worn, cachectic and ill able to get about. The case was referred as one of sepsis

believed to be due to the character of cases the physician had been handling in his practice.

In a study of the conditions during the time the case was under observation, the author became convinced that the process was secondary to the use of the X ray, rather than a septic condition secondary to the carbuncle. Suffice it to say, however, that no foci of inflammation went on to supuration after treatment was instituted by means of light. Each pustule was treated by means of the concentrated energy of (1) a carbon arc or (2) of an iron arc, according as to whether he presented himself at the author's private office or at her teaching clinic, for from 5 to 10 minutes; compression being used in either event. The carbon arc was given the preference, and there was conjoined with it upon the days he visited the office a 20 to 25 minute exposure of the upper nude body in the electric arc bath, because of his systemic condition.

In all there were from 6 to 8 exposures to the combined action of the concentrated light energy and that of the light bath.

Improvement began immediately, and every inflammatory pustule was aborted. The wounds from previous incisions healed rapidly, the skin became normal, the arm mobile and the patient's general health improved most rapidly, as evidenced by improved circulation, good skin coloring, increased appetite, better digestion, gain in weight and strength. All told he was under observation but 10 days, and during the latter part of that time not for the treatment of the arm, as the necessity no longer existed, but for the purpose of establishing the best possible condition of the general nutrition.

Tubercular Joints.—Tsiechauski<sup>1</sup> has reported eight cases of tubercular joint conditions successfully treated with the energy of the electric arc. He used arcs of from 80 to 100 ampères at 35 to 40 volt pressure or light of 12,000

---

<sup>1</sup>Prakt. Vrach, Aug. 31, 1902.

candle-power. From his experience he concluded that the complex of energy represented by the electric arc in the treatment of articular tuberculosis gives favorable results, is absolutely painless, and replaces altogether all the other methods of treatment.

It must always be kept in mind that the radiations of the electric arc, like the radiations of solar light, are carriers of energy, and when intercepted as they are by the interposition of the body (as a whole or a part, as in a tubercular joint) they do work, producing heat, vision or chemical action according to circumstances. In this instance the action is twofold, i.e., the thermal effect and the chemical effect.

Each in turn undergo still further modification in effect within the tissues dependent upon their action upon the superficies, determining chemical, osmotic and molecular changes of a nature favorable to the promotion of the nutrition not only of the part, but of the entire organism as well.

The author personally has had no opportunity to use light in tubercular joints, but from experience with tuberculosis pulmonalis, is of the opinion that light energy should avail much in this class of cases. The experience of Kaiser with the visible chemical frequencies need only be recalled to emphasize this statement, viz., the cure of tubercular abscesses of the thigh by chemically active light energy. For this purpose the parallel or converged rays of electric arc should be used directed against the part to be treated.

A mechanism by which the rays may be converged upon the part, as in the marine searchlight, is indicated. The arc should consume at least 25 ampères. A higher ampèrage with the larger carbons means a greater unit of area of light and a source of greater energy. The duration of the exposures should be from 20 to 45 minutes, according to the patient's tolerance and from once a day, at first, to three times a week later on, the nutritional changes governing the operator as to frequency and length of treatment. Every tubercular patient, whether it is a joint or lung case, should receive not only the topical but general treatment as well.

To this end the entire superficies of the body should be exposed to the action of the light as well as the joint.

In deeply involved and infiltrated joints the use of adrenalin cataphorically is advised. By the use of a large block-tin contact, placed over the lint or cotton wetted with adrenalin 1-1000 and attached to the anode, the entire knee or elbow for example could be dehæmatized to such an extent as to secure greater penetration of the energy of the arc and therefore more profound and lasting effects.

The use of an Esmarch bandage is recommended by Freund for the purpose of rendering joints anæmic. As the joints in young children are very transparent he states that they could readily be made bloodless in this way. From the author's experience with tuberculosis pulmonalis, it does not seem that it is necessary to render the part absolutely anæmic. If the blood is cut off from the more superficial tissues there is opportunity offered, however, for a greater action of the light energy, an action which in turn is capable of influencing deeper tissues.

According to Freund, G. Hurtado<sup>1</sup> claims to have cured arthritis tuberculosa in the elbow by this means. The use of light energy has also been recommended by Finsen in tubercular joints, where the tissues can be rendered partially or completely anæmic.

To every one equipped with suitable sources of light energy, the author would recommend its use in this class of cases. Especially would it be desirable that such work should be done in orthopedic hospitals and practice in order to establish the true value of the method.

The treatment of tuberculous joints is also referred to under the use of solar light energy.

In the electro-therapeutic laboratory l'Hôpital de la Charité of Paris,<sup>2</sup> a child 11 years old with tubercular

---

<sup>1</sup>Freund, Radiotherapy, p. 572.

<sup>2</sup>The Phototherapy of Adenitis and of Tubercular Arthritis, *Revue Internationale d'Électrothérapie et Radiothérapie*, Jan., 1904. Abstract from *La Semaine Médicale*.



arthritis of elbow complicated with a fistula was treated by means of light. In five months the cure was complete. It was noted that on exposure of the diseased parts to the light of electric lamps, placed at a distance less than 20 centimetres, there would be immediately a diminution of pain, of stiffness, and of the functional disability, so that slight movements of flexion and extension of the diseased joint, which could not be practiced before without causing acute pain, became possible and provoked only a very slight painful sensation. This amelioration continued up to resolution. The author admits that where the lesion is already advanced its progress would not be stopped by an expenditure of light energy, but that it would go on to suppuration. Favorable results follow its use, however, in diminishing the sero-purulent oozing and in preventing the formation of the extensive fistulous tracts, that one often sees in surgical tuberculosis.

This author concludes that in the use of light in these conditions, as in treatment of all dermatoses, the rays ought not to be pushed to the production of phlyctenules; they seem to carry an obstacle to the deep penetration of the radiations, forming a sort of isolating glaze.

Chronic Synovitis.—In inflammations involving the articulating surfaces of joints and the synovial membranes light energy should be of great avail. The more recent the condition, the more promptly and completely will it yield to the use of light. This is by reason of the fact that the products of the inflammatory action are not well organized and circulatory changes, with consequent absorption, are more readily established.

At this writing a case of chronic synovitis, involving the left knee in a woman, aged 60, of from 3 to 4 years' duration, due to an injury is under care. The contour of the knee was changed from the normal, the entire joint much enlarged, fluid under the patella and in the bursæ, extreme roughening of the articular surfaces, pain on movement, great disability and inability to put the heel to the floor on first rising. In this case the continuous current was used at first with the

hope that absorption might be stimulated. There was no appreciable effect from some six applications, however. The joint had been treated with hot air, i.e., baked prior to the patient's coming under the author's care. Treatment was then instituted by means of the concentrated energy of the marine searchlight, at a varying distance of from 6 to 8 feet, and the mechanism adjusted so as to bring the parallel rays to a focus at that distance and the size of the focal spot sufficient to cover the entire joint area. The sittings in this case have only averaged one a week as the patient is unable, because of the heat and the fact that she is at her country home, to come oftener without too great fatigue. Each exposure has been from 30 to 45 minutes in duration. On two occasions exposures were made to the concentrated energy of the Victor lamp, 17 ampère carbon and iron contacts, directly over the fluid filled bursæ, with the hope that a more prompt absorption would be stimulated by the reaction upon the skin. From 8 to 9 exposures to the action of the light have been made, including the concentrated energy of the Victor lamp. The knee is smaller, there is diminished grating and absorption of part of the fluid. The patient can put her heel to the floor, does not limp so badly, the joint feels stronger and the circulation is improved. As yet the author notes only improvement in the syndrome, but expects, when treatment is reinstated after the heat of the summer, with more frequent exposures, to modify the conditions to a much greater extent.

Recent Inflammations (Rheumatic) and Injuries to Joints.—In recent injuries to the smaller joints the author has obtained from a single exposure to the concentrated energy of the carbon arc (no inflammatory skin reaction excited) relief from pain, soreness and disability. A second and a third treatment has sufficed, this with the heat eliminated.

With the same mechanism a subacute rheumatic joint (metacarpo-phalangeal, thumb) several months' duration, swollen and painful, was relieved by a single exposure of

twenty minutes without elimination of the heat. The immediate relief from pain passed into a complete cure in a few days following treatment. Thus there are a host of ailments from which patients suffer, of no great magnitude nor moment, which can be readily relieved by the action of light energy. To the physician caring for graver pathologies they may not seem worthy of attention, but the author finds that every relief afforded from pain and disability in these minor conditions is a factor in the better being of the individual. In the larger joints, more extensively involved whether from injury—a sprain and contusion—or from a rheumatic inflammation the results should be equally good. It is only necessary to suitably adapt the means to the end.

**Tubercular Ulcers.**—Ravogli<sup>1</sup> reports a case of tubercular ulcer which yielded to the use of condensed light in a few weeks, from 15 minute exposures, twice a week.

The ulcerated area, the size of the palm of the hand, was situated on the dorsal region, just above the angle of the left scapula. It consisted of small ulcerated nodules, somewhat elevated above the level of the skin, coalescing together. The centers of the nodules were mostly ulcerated, showing a yellowish lardaceous bottom.

The exposure to the light stopped the itching and burning sensation. The entire surface became red and erythematous, the ulcers appeared as if painted with gelatin, the yellowish necrotic appearance disappeared, and in a short time they healed up, the small tubercles disappeared, a healthy cicatrix formed extending from the edges toward the center, the patient making a complete recovery.

**Tubercular Glands.**—These also lend themselves to the action of light energy. At the present writing the author has a case under care for which the concentrated energy of a 25 ampère iron cored carbon arc is being used. The sittings are three times weekly and from 30 to 45 minutes in

---

<sup>1</sup>A. Ravogli, M.D.: *Journal Cutaneous and Genito-Urinary Diseases*, Jan., 1902.

duration. On one side of the neck a recent and deep cicatrix following the removal of a very large gland was apparent when she came under care. She suffered great pain all along the site of the scar and the parts were exquisitely sensitive. She also suffered severe neuralgic pains throughout the entire nerve distribution of that side of neck, face and head. The operation had left her with ptosis of one lid. There were several enlarged glands lying near the line of incision as well as on the opposite side of the neck. The case is improving both in so far as the enlargement and sensitiveness of the glands are concerned and in her general health. The severe neuralgic pains were relieved from the first, the cicatrix is softening and is less deep than at first. After two or three exposures, the wound opened up, showing that a fistulous tract had been left. This is evidently closed up as the discharge, sensitiveness and pain have disappeared. The ptosis is slightly improved with her general improvement.

Tuberculosis Pulmonalis. — Foveau de Courmelles<sup>1</sup> (Société de Biologie, Institut de France, December 24, 1900) found the chemical frequencies from an arc lamp of 12 ampères at 80 volts in which the thermal frequencies were filtered out by means of water, of value not only in the treatment of lupus vulgaris and lupus erythematosus as well as in various other dermatoses, but in pulmonary tuberculosis also. He used the chemical frequencies with a compressing lens of quartz. He seemed to regard the use of light in this condition as an entirely new observation. But light had been used in the treatment of pulmonary tuberculosis for some years, the author having employed all the radiant energies of the arc in the same class of cases since 1895. Courmelles reports a case of lupus with cutaneous and osseous lesions of twelve years' standing associated with cough and a slight *souffle* at the apex of the left lung, treated at the Hospital of Saint Louis by means of the chemical frequencies, as indi-

---

<sup>1</sup>Foveau de Courmelles, Standard. Abst. in Journal Phys. Therapeutics, Jan. 15, 1902.

cated above. After five sittings of 10 minutes each, the *souffle* had disappeared (September, 1901). Since then various tuberculosis patients had been treated, all experiencing an immediate sense of well-being followed by diminution in the cough and improvement in the stethoscopic signs. These results obtained from the use of cold light concentrated, localized, and used with a compressor, are the same as obtained by the author from the energies of the entire arc spectrum as well as its gaseous envelope and the ionization of the air. For there is every reason to believe that all these factors enter into a treatment by a diffused arc light in a comparatively limited space. Hopkins<sup>1</sup> reports two cases in detail with a similar result. He utilized a 50 ampère arc with a 20 inch condensing lens (a marine search-light in fact), arranged so that the light could be concentrated on a surface an inch in diameter at a distance of 15 feet if desired. The application, however, consisted in focusing the light at a distance of 15 feet so as to secure a beam of from 15 to 20 inches in diameter. This beam was then directed to the chest of the nude patient, the exposure varying according to the tolerance of the patient from a half of an hour to an hour in duration. Ten cases in all had been treated with relief in every case from cough, temperature, expectoration and sweats within the first few days.

The blue glass screen shown in Fig. 21 is used by Hopkins in order to sift out the heat. The method resolves itself, therefore, into the use of the concentrated visible chemical frequencies of the electric arc.

The experience gained in many of the skin conditions enumerated is, however, too limited to formulate any definite opinion as to the place of light energy in their therapeutics. Strebel and Barbensi have made use of light in furunculosis. Here the author would expect to secure good results. Leredde has treated rhinophyma and Strebel, Barbensi and G. J. Müller psoriasis. The author's experience

---

<sup>1</sup>Hopkins: The Phila. Medical Journal, Sept. 21, 1901.

with the latter condition has been given in Chapter IX. under Electric Arc Baths. Favus has been treated by Finsen and biskra-button by Petersen.<sup>1</sup>

Müller and others, according to Freund are authority for the statement that varicose ulcers, septic wounds, fistula after operation on bubo, etc., heal more quickly under the action of light energy. The author can corroborate this statement from clinical experience in some of the same and in similar pathological conditions.

Concentrated Electric Arc-Light Energy in Gynæcology. —Concentrated light has also been used as supplementary to the X ray treatment of very extensive pelvic epitheliomas, not as a curative agent but as a palliative one. By its use the pain and irritability attendant upon extensive inoperable pelvic epitheliomas, involving vaginal walls, cervix uteri, broad ligaments, rectum, bladder and, in some instances, the fundus uteri as well, has been relieved. Patients of this character have experienced much relief from pain, hemorrhage and ill-smelling discharge. All of which has meant a sense of well-being. In each instance it is the chemical action induced by, on the one hand, the rhythmic ultra-violet light energy, and on the other, the infrequent solitary pulse of X ray energy. From the very nature of the pathology it follows that a prolonged expenditure of the light or X ray energy is desirable. Thus far experience teaches us that prolonged applications of the X rays are to be avoided because of the danger of too extensive action upon the tissues. This is not true of light energy.

The patient is placed upon an operating table in the usual dorsal position for treatment. A glass speculum, funnel-shaped, at its proximal end, is then introduced. As glass does not permit the passage of the ultra-violet rays the lower vaginal walls are not exposed to this action but, on the other hand, the opening at the distal end secures the greatest expenditure of energy at the point of greatest pathological activity.

---

<sup>1</sup>Quoted by Freund.

The operating table is then wheeled sufficiently close to the arc light mechanism to permit the distal end of the funnel-shaped lid to project into the flare of the speculum, at a distance of from 6 to 8 inches from the introitus or in actual contact with the expanded rim of the speculum. It must be kept in mind that a mechanism is being used, the focus of which can be changed at will by the position of its carbons. The light is then turned on and the full force of the beam is projected directly into the vagina and against the exposed cervix uteri. An oblique position of the speculum brings into view the area of diseased tissue in the right fornix. A daily application, 20 minutes in length, is made, sometimes following the X ray and sometimes alone. There is neither pain nor discomfort, save from the prolonged dorsal decubitus upon the operating table. The whole vagina glows with violet light, but the full force of the chemical frequencies impinge upon the cervix uteri and vaginal vault, while less directly they must influence the broad ligaments.

In instituting treatment in this class of cases, light was used prior to the X ray and from single applications hemorrhage was controlled, odor markedly diminished, amount of discharge lessened and the character changed for the better.

Exposure of the entire abdomen to the beam of light 10 to 12 inches in diameter from the marine searchlight, has also been a source of great comfort to these patients mitigating all hemorrhage and distressing symptoms. It has, therefore, been used both intra-vaginally and to the abdominal walls as a palliative measure.

This same method is used by Hopkins<sup>1</sup> in the treatment of cases of pelvic cancer. He has utilized a Finsen tube, directing the beam of light at its focal point to the diseased cervix. His experience is corroborative of that of the author in the relief of pain, of hemorrhage, and creating a sense of well-being. He makes exposures of an hour or more.

---

<sup>1</sup>Brooklyn Medical Journal.

The Nature of the Changes Established by the Action of Concentrated Light Energy.—The macroscopical changes observed in the pathological condition in lupus, where the nodules are considerably elevated, i.e., hypertrophic, are these. When they have been sufficiently treated, the nodules and the raised edges of the lesions become flattened, and in the middle show a kind of necrotic appearance and then disappear. After two or three applications small nodules are scarcely recognizable, and where formerly confluent nodules formed continuous lupus infiltrations, isolated nodules appear with strips of healthy skin between them.

In ulcerated lupus areas the effect of the light treatment is to relieve after a 15 minute exposure, the troublesome subjective symptoms. Pain is abolished, itching if present ceases and there is experienced a sense of warmth and comfort in the part treated. This relief does not pass with the treatment but tends rather to an increased sense of well-being in the part for some time after exposure. Under the action of the light the surface of the lesion becomes shiny, as if it had been covered with a film of gelatin. They grow less both in surface extent and in depth and cicatrize. The redness of the skin gradually passes away, giving place to the normal coloring. The cosmetic effect as regards the appearance of the skin is all that can be desired, the new skin formed being soft and smooth like a baby's. The same is true of the scars. There is very little loss of substance and such as there is arises from the morbid process and in no sense is due to the treatment. The normal tissues are not affected by the treatment at all.

Finsen's treatment, beginning, as it properly does, at the periphery and taking in the healthy skin, has the effect at once of checking the spread of destructive lupus processes. The action of the light on lupus is not only an immediate but also a lasting one, going on even after the treatment is stopped. Suspicious spots have often been known to resume a healthy appearance following the suspension of treatment, even after several months. It was because of this fact that



Finsen concluded that the tubercle bacilli are killed by the light in a much shorter time than is required for the slow process of transforming the diseased reddish-brown tissues into healthy skin of a normal color.

The author does not believe that the curative action of light energy is due to its bactericidal action *per se*. The experiments of Bernard and Morgan, also those of Freund, prove very conclusively that light exerts no direct bactericidal action upon living tissues. In the treatment of curable cases of pulmonary tuberculosis with all the radiant energy of the arc, the bacilli gradually disappear from the sputum, not because they are killed, but first, because the physiologic resistance of the individual is increased by the action of light upon the blood, and second, the same oscillating swing of the corpuscles of the chemical frequencies of light energy, which in the one instance stimulates physiological processes, in the other serves to inhibit their action. The author is decidedly of the opinion as are Sophus Bang,<sup>1</sup> G. J. Müller, Glebowsky, Serapin, Sack and H. E. Schmidt<sup>2</sup> and Freund, that the action of the light in exciting tissue reaction is fundamental. Freund<sup>3</sup> believes that light acts as an irritant, penetrating, like the Roentgen rays, very deeply. According to him its action goes deeper than that of many chemical irritants, such as pyrogallic acid, resorcin and lactic acid, the effect of which is weakened by the albumen compound soon formed. The light irritant stimulates the granulation of tissue, which is usually but little inclined to change into connective tissue, to the formation of connective tissue and cicatrices. Probably the extraordinarily powerful illumination acts on the diseased tissues which are specially sensitive to light and less able to resist its action as a hyper-irritant, and thus, as is well known, kills the cells. By this means the morbid tissues are destroyed and prepared for absorption.

These histological changes are studied in detail in the following pages.

<sup>1</sup>VII. Congr. de Deutsch. Dermatolog. Gesellsch., Breslau, 1901.

<sup>2</sup>Berlin, klin. Wochenschr., 1901, No. 32.

<sup>3</sup>Freund, Radiotherapy.

Macroscopic Reactions.—When a patient has submitted to the action of light from a Finsen concentrator for an hour, the Victor lamp (original Lortet and Genoud), or some one of the many devices in use for from 15 to 20 minutes, there are no immediate modifications at the point treated. There follows upon the action of the light the development of an erythema at varying periods of time, depending upon the nature of the skin, and the richness in ultra-violet frequencies of the source of light, from a fraction of an hour to 4, 6, 8, perhaps 12-24 hours and sometimes even as late as two days after. The longer and the more profound the action of the chemical light energy, the later is the reaction in appearing.

Shortly after the appearance of the redness an œdema more or less marked appears. In the event of a thickened or hyper-pigmented skin having presented an obstacle to the penetration of the light energy or if the exposure has not been long enough the reaction stops there. Usually, however, at the same time as the œdema there appears a serous exudation which coagulates in more or less thick yellow crusts.

In a considerable number of patients this characteristic dermatitis goes on to the formation of true bullæ, phylctenules, full of liquid, which likewise end in a crust. The time of their appearance varies according to the time in which the reaction establishes itself.

On an average eight days after exposure of a part to the light energy, all inflammatory reaction will have disappeared and the opportunity is offered for judging of the results which have been obtained.

Here again in this late reaction is shown the difference between the action of light and heat.

Chemical Light Reaction not a Destructive Process.—No matter if the séance be prolonged and with a powerful source of light energy, the Finsen concentrator with an 80-ampère arc used for two hours, for example, no loss of substance will be provoked. The same is true of other light

mechanisms. Just here it may be well to reiterate that the amount of penetration is in no sense dependent upon the production of an inflammatory action upon the skin. The concentrated complex of the energy of a carbon arc is capable of penetrating very deeply with a minimum of superficial inflammatory action; an iron arc, on the other hand, will produce an intense erythema, but penetrates scarcely at all.

If the séances are of unusual length, the reaction, as has been indicated, is slow in appearing and of longer duration. There may succeed an erosion to the phlyctenules, which, however, repairs itself in a few days.

Microscopic Reactions.—It will be recalled in this connection that it was not until the eighth day that important dermic reactions were observed by Leredde and Pautrier. There was observed at that time a state of increased hyaline tumefaction of the connective tissue. Some of the minute blood vessels were dilated, the endothelial cells of which presented some figures of karyokinesis. The connective tissue cells were equally tumefied, more prominent, and karyokinesis in places. Finally red blood cells were observed scattered outside the vessels, lymphocytes forming little masses in various places appearing to occupy the lymphatic spaces, and the mast cells were more numerous than normal. In a word it simply resolves itself into a condition of an acute inflammation. From this state of acute inflammation the consecutive process of repair and cicatrization is easily explained.

This then summarizes the histological reaction in the healthy tissue.

The Nature of the Regressive and Productive Tissue Changes Leading to Healing which takes Place in Lupus, Ulcus Rodens and Vascular Nævus under the Influence of Ultra-Violet Rays.—Sack, whose histological investigations were made upon Lupus, Ulcus Rodens and Nævus Vasculosus planus,<sup>1</sup> has shown that the first effect of light is upon

---

<sup>1</sup>Muenchener Med. Wochenschrift. July 8, 1902. A. Sack.

the blood vessels and that the first changes noted are swelling and proliferation of the endothelium. This is observed in its simplest form in uncomplicated angioma of the skin, and results in an endo-vasculitis with final obliteration of the vessels. There is nothing in the entire process related to burning or cauterization. In the latter, the reaction appears promptly, with the former later, and this fact negatives such a supposition. The clinical course of the process is also opposed to the condition produced by thermal frequencies. The absence of the coagulation necrosis, which accompanies every burning and cauterization, also precludes the possibility of any thermal influence. But even so, this is not needed as evidence, when the light is used in such a way as to obtain only the chemical activities or cold light. This then is conclusive, because not only the histological changes do not resemble those produced by burning, but there is an absence of thermal frequencies.

The histological changes established are very clearly shown in the complicated structure of a lupus nodule. The regressive changes are purely selective, in that they only affect certain elements, and these are the least resistant, of the diseased tissues, while the other elements both within and without the diseased focus are incited to increased activity. By the irritating influence of concentrated chemical frequencies, there are produced in the cells of the diseased skin such conditions as to make it possible for those not wholly diseased to recover and overcome the diseased ones. By reason of this action of the chemical frequencies of light visible and invisible, certain of the cell elements are absorbed (those of perverted or deficient vitality) while others become connective tissue cells, with the result of establishing actual healing. The process resembles a necrobiosis. Cells which are not hopelessly diseased undergo a retrogressive metamorphosis under the influence of the ultra-violet light, which seems to act as a physiological irritation. Histologically, blood vessels dilate, and an exudate is formed, mainly of leucocytes. Pigmentation follows from the exudation of

erythrocytes. The inflammation established by reason of the action of the light causes a successive and gradual regression of the disease. This is demonstrated by the diminished congestion and by the reabsorption of the infiltration. Glebowsky,<sup>1</sup> who has also made a careful histological study of the process of healing of lupus in the skin under the influence of light, reached the following conclusions: Twenty-four hours after irradiation by the chemical frequencies of light, pieces of the skin were removed. Upon examination, the vessels were found dilated and the surrounding tissues infiltrated with migrating leucocytes. In addition, the interstices of the connective tissue were somewhat wider, and slight vacuolization existed which was clearly marked in the giant cells.

In sections removed after 48 hours the same phenomena were much more marked and there was also fatty degeneration of the protoplasm and necrobiotic changes in the nuclei of the granuloma cells, especially in the giant cells (pyknosis and chromatolysis). Fig. 28<sup>2</sup> represents a giant cell from a case of lupus, two days after Finsen treatment, originally presented by Glebowsky to the German dermatological congress in which there is shown p. (pyknosis), v (vacuolized nuclei), k (fat).

After repeated sittings, the destructive appearances in the giant cells increase, and finally the cells disappear entirely. This, Glebowsky found, follows as a rule, after from four to five applications of ultra-violet light. The process of degeneration in the epithelioid elements was much less marked than in the granuloma elements. In them, Glebowsky and Serapin observed changes of a purely progressive character, for example, elongations of the nuclei and the cell bodies and elements of a spindle shape were met with, and these, in time, seemed to pass into fibres. During the acute

---

<sup>1</sup>C. Serapin, Ueber die Veränderungen in Lupus granulom unter der Einwirkung des concentrirten Bogenlichtes, etc. VII. Congress d. Deutch. dermatolog. Gesellsch. Verhandlungs-bericht, p. 500 ff.

<sup>2</sup>Freund: Radiotherapy, p. 503.

reaction, the lymphoid elements of lupus showed rather pronounced fatty degeneration, and later on, oval and spindle-shaped cells were observed among them. Beginning with the upper layers of the corium, the cell elements in the granuloma disappeared more and more, as the reaction established by the treatment advanced and died away, the connective tissue becoming more and more conspicuous. This is shown in Fig. 29.<sup>1</sup> A lupus nodule after four sittings. (From Glebowsky-Serapin) (a) blood vessels with hyperplasia of the endothelium, (e) granulation elements between the epithelioid cells, (f) connective tissue. Only at the end of the treatment were the numerous blood vessels contained in the granuloma quite obliterated. According to Freund, there has not been obtained such a variety of effects in epithelioid elements from the use of the Roentgen ray, and in this fact he finds a point of difference between the treatment of lupus by the chemical frequencies of light and the Roentgen ray.

In addition to Glebowsky's and Sack's study of the histological changes taking place in lupic processes and those of the latter in *Ulcus Rodens* and vascular *nævi* the histological changes in lupus have also been studied by Leredde and Pautrier. The latter form an admirable study of the minute histological changes.

Biopsy on Tissue of a Lupus Patient after Several Treatments and Following upon a Quiescent Period of Fifteen Days.—Upon examination a white fibrous network between the meshes of which a violaceous tint persists without lupus tubercles, was observed. Under a low magnifying lens the epidermis formed a thick layer comprising 12-15 layers of Malpighian cells of normal size. They are regularly arranged and separated by some migratory cells. Under a high power magnifying lens the cellular spaces are a little enlarged and there is a little of the "état-spongoïde of Unna" and here and there some cells which present the "état-cavitaire of Leloir." A similar condition was observed in the

---

<sup>1</sup>Freund: Radiotherapy, p. 505.

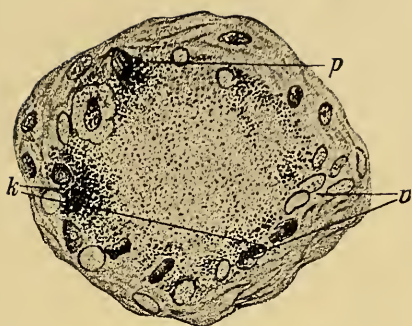

Fig. 28.

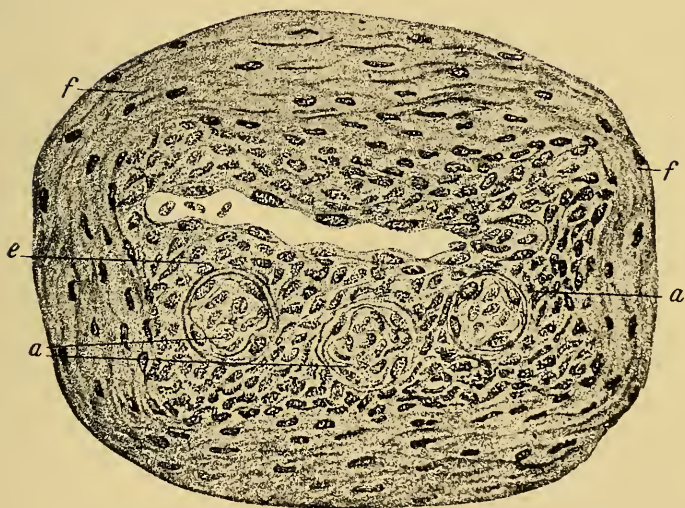

Fig. 29.





normal tissue. Papillæ exist only at rare points; in general a union of the dermis and epidermis is upon a line parallel to the cutaneous surface.

There is observed in the derma: (1) A universal sclerous transformation formed of connective tissue bundles slightly crowded; (2) vessels very much dilated and numerous, fewer where the sclerosis is more advanced and with very thin walls; (3) some few cellular nodules disposed in contact with the vessels and which are formed only in a lateral part of the preparation, while all the rest are formed of an almost homogeneous sclerous tissue.

Under the higher power a slight hyperkeratosis without parakeratosis is noted in the corneous layer. The granular layer is remarkable for its thickness. Upon the points of the projections there are found some small epidermic projections formed by collections of large cells covered with a thin corneous layer.

There are found between the Malpighian cells a number of cells of dermic origin with elongated nucleus of indeterminate cytologic variety. Some are distinguishable from mast cells with their characteristic granules. Very rarely eosinophiles are observed whose granules are scarcely distinct. There is observed in the mucous body, rete mucosum, the presence of figures of karyokinesis, a little more numerous than normally. They are not only found in the basal layer but a little above it as well.

At the level of the basal layer there are observed some very fine cells extremely flattened, which are stuffed with pigment and which evidently take their origin below the basal layer to the limit even of the derma, by a sort of a foot insinuated between the cells of this layer.

Pigment.—There are found globes of pigment isolated and intercellular. The Malpighian cells are themselves charged with pigment, under the form of fine ochre granules, numerous at the level of the superior pole of the cells.

The aspect of the derma varies according to whether it is the sclerous region with or without nodules. In the

sclerous region without cellular nodules, the tissue is formed of small connective tissue bundles, parallel with each other, slightly dense, separated by flat cells, very much elongated. There are found a great number of mast cells equally flattened; exceptionally one or two round cells, with nucleus of connective type, leaning against the wall of the vessels.

In the nodular region, the most important of them are formed of cells with rounded nuclei, without important protoplasm, having the characteristics of lymphocytes; at the limit some mast cells can be found. Other nodules, perivascular, are formed by very large plasma cells of typical character.

There also exists generally in this region extremely numerous and large mast cells, always isolated and of various forms, globular and drawn out.

At some points there are found masses of large colored nuclei, with diffuse chromatin, presenting the characters of fixed yellow cells, a large number of which are found in different stages of karyokinesis. These nuclei are found mingled with plasma cells, and it seems as if the transformation of the lupic nodules was assisted by hypergenesis of the fixed cells.

The Process of Cicatrization.—This is in substance a fibro-sclerotic transformation of the skin, occurring in an extremely regular manner, without epidermic atrophy and without important dermic atrophy.

This transformation is established by formation of young connective tissue in the regions evacuated by the lupus. The presence of more numerous vessels in the region of the lupic nodules than in others corresponds to the progressive devascularization of the tissue which characterized it clinically.

In the regularity and thickness of the epidermic layers is to be found the explanation of the regularity of the cicatrices.

The thickness, despite the pigmentation of the deep layers of the epidermis, assures the relative whiteness, so characteristic of the condition of the skin subjected to the action of light energy.

Nature of the Liquid which Forms the Phlyctenule.—In common with all organic liquids this presents an alkaline reaction. Its cellular formula shows a very great richness in eosinophiles, as is evidenced by the proportions in the following table :

Eosinophiles .....	56.1 per 100
Polynuclears .....	14.8 per 100
Mononuclears .....	7.4 per 100
Red globules .....	21.7 per 100

Upon examination of the plates all the cellular elements appeared upon a foundation formed by the uniformly orange-colored liquid, which was like a true lacquer. This liquid is very rich in fibrin and it is this which, in the light reaction, gives rise to the yellow crusts which form from the phlyctenules.

In this very complete histological study of the minute changes which take place in a lupous process, in connection with those of Sack and Glebowsky, there is afforded incontrovertible evidence of the nature of the changes established which serve to fix most firmly the foundation for the science of light energy in all skin pathologies.

## CHAPTER XIII.

The Concentrated Energy of Incandescent Light Spectra, Mechanisms, Methods of Use and Therapeutic Indications, Local Incandescent Baths, Rheumatic Joints, Chronic Synovitis, etc. Incandescent Light in Gynæcology.

### **The Concentrated Energy of Incandescent Light Energy.**

In the many uses of light energy from the various sources of light, there exist always the need (1) for an application of the energy when diffused into considerable space, as in a bath, or (2) in concentrating that energy either within or upon a part.

One of the most important uses of the concentrated energy of an incandescent lamp is that known by the name of Minim; but as it does not include the entire energy, only that of the visible chemical frequencies or blue light, it is considered under the frequencies of the blue region, rather than here. In this connection it is necessary to refer to (1) the use of the energy of the incandescent light spectra from one or a group of lamps upon a part, as, for example, in the treatment of a rheumatic joint, and (2) the use of miniature lamps within accessible mucous cavities, the vagina, rectum, bladder, nose and in the ear.

The spectrum of the incandescent light is deficient, as has been stated, in the more chemically active frequencies. It bears no comparison to that of the sun nor of the electric arc. Both are much richer in the blue, indigo and violet than the incandescent, and the electric arc by its exceeding richness in both blue-violet and ultra-violet far surpasses the incan-

descent lamp as a source of light energy of intense chemical activity. The sun is also much richer than either in the blue violet, but feeble as the incandescent lamp is in chemical energy, it is still capable when skilfully used of much good. The luminous efficiency of an incandescent lamp is but about one-third that of the electric arc, while poor in blue, indigo and violet frequencies it is rich in green, yellow and red frequencies. Because of the glass-enclosing bulb such ultra-violet frequencies above 30 micro-centimetres in length as this source of light may generate are of no therapeutic value.

Both the chemical and the luminous efficiency may be increased by increasing the current. Therefore where the most intense effect is desired from the concentrated energy of one or more incandescent lamps, the higher candle-power should be used. For example, a 32 candle-power will give out more of the valuable blue-violet frequencies than a 16; while a 50 candle-power will produce a still more powerful effect. The degree of energy should bear a relation to the abnormal condition for which it is used.

Mechanisms for the Use of the Concentrated Energy of the Incandescent Light Spectrum in the Treatment of Joints, Etc.—For this purpose a partial bath of incandescent light is used. The arrangement of the particular mechanism depends upon the anatomical locality to be treated.

A simple arrangement of a hoop in the concavity of which are placed a few incandescent lamps of varying candle-power, from a 16 to a 50, according to the degree of light intensity desired, may be improvised, where the more complete and elaborate equipment is wanting. This can be placed over the affected joint, as the knee, and a blanket thrown over it. In this way the indications for a local radiant energy bath to a rheumatic joint can be adequately met at a patient's house or for that matter in the physician's office.

The small boxes of suitable size and shape provided with reflecting surfaces and with the incandescent lamps fixed to the side and with suitable openings for the insertion of a

limb, or a group of lamps provided with reflector are to be preferred, however.

The device of Hedley referred to in the chapter devoted to incandescent light baths comes under this head. This device consisted of incandescent lamps each carrying 2.5 ampères of current fixed in reflectors.

A single lamp may be placed in the centre of a reflecting cone for the treatment of a hand or a foot for example. A similar arrangement may also be used for a strictly localized spinal application or to any part of the body where a strict localization is desired.

The thermal effect, and for that matter the chemical as well, may be regulated by (1) the distance of the lamp from the part (2) by the number of lamps and (3) by the regulating device or rheostat.

Freund uses two incandescent lamps of 100 normal candle-power, each with its own cut-out switch, which are fixed in a parabolic metal reflector. The conducting wires of these different arrangements of incandescent light mechanisms for radiant energy baths, whether local or general, may be carried to a rheostat by means of which the current may be carefully graduated and the lamps made to glow more or less brightly according to the light intensity desired. In using concentrated incandescent light energy, it is better to thus control the intensity of the light of the group rather than to do so by cutting out one or more lamps. In Freund's apparatus the reflector on its open side has colored glass filters or fluids. This apparatus may be fixed to a stand.

For the extremities there are used drum-shaped boxes (see Fig. 30) into which groups of lamps, 2, 4, 6, 8 or more, according to the size of the part, the condition, and the degree of light intensity necessary, are placed. In these an opening may be cut in the thickest part of the casing, the exact size of the reflector, into which it can then be fitted. In minor points the construction of these mechanisms is different but the essential principle is the same in all. The

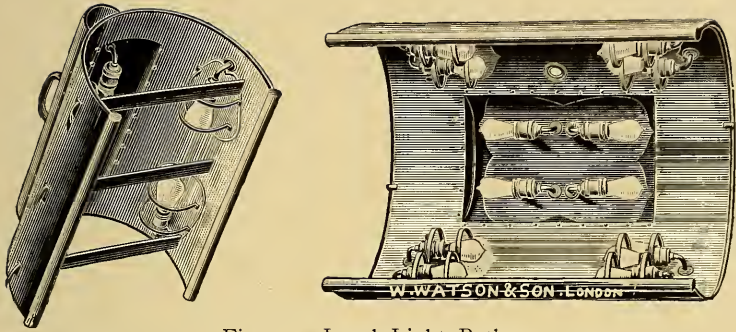

Fig. 30.—Local Light Baths.



Fig. 31.





drum is placed on two supports and fixed with straps. In this position it can be turned so that the light energy may be distributed upon all parts of the extremity to be treated. A netting of asbestos may be stretched inside the drum at some distance from the reflector to prevent the exposed limb from coming too near the lamps.

An encasing framework covered with heat-retaining material is also constructed for the treatment of the trunk. It is an incomplete cylinder and may be termed trough-shaped. There is a rectangular opening at the top into which the reflector is placed and the two open ends are closed by curtains of the same material as the cover. Below the opening into which the reflector is placed but attached to the rollers on the outside of the wooden frame is a thick close curtain of asbestos, consisting of two nets, one coarse and the other fine-meshed, superimposed the one over the other. Then by drawing the one or the other part of the curtain by means of the rollers the strength of the light energy may be varied. Such an apparatus may be used without a reflector, although by its presence there is an intensification of the radiant energy.

These as well as all apparatus for the administration of general or local light baths should be fitted with thermometers.

A very desirable local bath of incandescent lamps can be readily arranged for an application of the light energy to the spine. For this purpose a rectangular box the length of the cord or spine as well, into which from 8 to 10 lamps are placed, the sockets alternating on the sides of the box, is permanently adjusted to the wall. An adjustable stool is placed just under and a little to the front of this mechanism upon which the patient is seated. The sides and ends of the rectangular box-like frame approximate closely enough the surface of the back to secure a strict concentration of the light energy. The interior of the enclosing frame should be finished with white enamel carefully put on, or mirrors in order to obtain a good reflecting surface.

These local baths are more flexible than the general bath, as they may be carried to the bedside of the bed-ridden patient, or they may be simply and inexpensively constructed for the more permanent use at the home of chronic invalids unable to come to the physician's office for treatment. Their use should, however, be always directed and supervised by the physician himself.

Temperature of Local Baths. —Applications of concentrated incandescent light energy can be made at a higher temperature than the general bath, which is often desirable. A general bath becomes unpleasant when the temperature reaches  $122^{\circ}\text{F}$ ., but in the administration of concentrated incandescent light energy as high a temperature as  $212^{\circ}\text{F}$ . can be readily borne, especially at the second or third exposure. From this concentration of the light upon a part, perspiration is not produced save at high temperatures, from  $194^{\circ}\text{F}$ . to  $221^{\circ}\text{F}$ ., but is generally very profuse. It will be recalled that in the general bath perspiration has resulted from a temperature of  $85^{\circ}\text{F}$ .

Physiological Action.—The physiological action of concentrated incandescent light energy is the same as that of the general. There is always produced by one exposure of the extremities a rise in temperature of the whole body as well as in the part treated. Freund reports that he has observed that after an exposure of from 30 to 45 minutes, when the temperature of the enclosing apparatus was about  $176^{\circ}\text{F}$ ., that patients reported themselves getting comfortably warm over the entire body. The face coincidentally becomes a little flushed and the temperature upon being carefully retaken showed a rise of from  $3^{\circ}$  to  $10^{\circ}\text{F}$ . The pulse, on the other hand, showed as a rule no change, seldom being even slightly accelerated. The respiration too was unaltered.

There is also a rise in local temperature. This increase in temperature may be explained in different ways: (1) The heating of the body by the direct transmission of heat from the apparatus into the tissues, (2) by the increased effect of the local temperature of the blood upon the entire

blood stream, (3) by a sympathetic rise in temperature through the nervous system.

The author agrees with Freund, who offers the above explanation that the first explanation may unquestionably be disregarded; the second and third conditions are both active, perhaps equally so. There must, however, be a decided temperature effect from the increased temperature of the blood, and as it is constantly in motion, this effect must be carried to every part of the body.

Effect on Skin Temperature.—This reaction from the effects of light and heat rays upon the skin temperature has recently been studied by Sommer<sup>1</sup> who used in his experiments the thermopalpation apparatus of Herz. He found that when no acute exacerbation of the process existed, the temperature of the skin over a chronically diseased joint was lower than that of the same joint of the opposite side. The action of heat and light rays always caused the temperature of the involved joint to rise higher than that of the normal side; however, cases occur in which the temperature under the influence of the rays is subnormal on both sides.

The light and heat rays do not cause a cooling reaction as follows cold and warm applications. Short applications of the rays cause an immediate rise of temperature which remains longer than if the application has been of longer application. After from 2 to 4 hours the relation between the two sides is reversed, i.e., the side exposed to the rays seems colder than the other, a condition brought about by the reaction of the unexposed side.

Therapeutic Indications.—The indications for the concentrated incandescent light energy is by no means confined to joints, but is indicated in injuries, sprains, contusions, ecchymoses, superficial inflammations and suppurations. The latter are extensively considered under the visible chemical frequencies of incandescent light energy or blue light as used more exclusively by Minim and Kaiser.

---

<sup>1</sup>E. Sommer, Berliner klinische Wochenschrift, Oct. 5, 1903.

While a certain amount of relief is obtained from the use of this method for the painful neuralgias and in neurotic conditions, the more chemically active energy of the arc should preferably be used. Concentrated incandescent light energy has been found useful in exudative processes, for example, from the inflammatory action of rheumatism, peritonitis, pleurisy and gonorrhœa, and is of assistance in the healing processes in subcutaneous, subperiosteal, and retinal effusions of blood; also in such skin affections as ulcerations, eczema, lupus, lepra and in venereal and syphilitic affections. In the above-named conditions the author gives the preference to the electric arc, but it is within her personal knowledge that the same class of results as those obtained by von Stein, Gatschorvsky, Minim, Makawejew, Kessler, Turner, Upensky, all quoted by Dworetzky,<sup>1</sup> and also by Tichomirow,<sup>2</sup> have been obtained by other physicians using concentrated incandescent light energy.

Freund<sup>2</sup> states that he has treated at times several long-standing cases of acne vulgaris, two cases of ulcerating Roentgen dermatitis referred to him by Professor Ehrmann, an ulcerating lupus and a scrofulous abscess which had been left in the neck after ulceration of the lymphatic glands and a syphilitic ulcer with (1) the entire energy of the incandescent light apparatus and (2) through a red glass filter (spectroscopically examined). In all these cases the disease was checked or modified save the syphilitic ulcer, which was unaffected and the scrofuloderma, which finally had to be treated surgically in spite of improvement at first, because of the ulceration of a neighboring gland. The induration around the acne nodules was less and fewer pustules were formed; the suppuration diminished in the small abscesses, whilst healthy granulation and surface healing were visibly furthered. The exposures in these cases were of half an hour's duration, with the diseased part as close as possible to

---

<sup>1</sup>Wratsch, 1900, No. 11.

<sup>2</sup>Freund, Radiotherapy and Phototherapy.

the source of the light energy. No other treatment was adopted save a simple vaseline dressing after each sitting. He does not state what difference in result was obtained from the entire incandescent spectrum and from that of the red region alone.

Had the syphilitic ulcer been exposed to the chemically active energy of a source of light rich in ultra-violet frequencies, the author believes that it is highly probable that healing might have been established.

Technique.—When the object is to powerfully stimulate a part, a rheumatic joint of long standing, for example, the apparatus should be heated beforehand to 122°F. When, however, no such sudden and powerful stimulation is desired the current need only be turned on after the apparatus is adjusted to the part.

The amount of thermally active energy must be graduated, so as to be tolerable to the patient. This may be done by diminishing the intensity of the radiant energy. (1) By means of the controlling resistance, (2) by turning off one or more lamps, (3) by turning the current off from all of them for a short time and then reapplying.

After-Treatment.—When free perspiration of the part is established, the part should be rubbed down thoroughly as after a general bath and massage and active and passive resistance movements, or electrical treatment applied. In some cases hydratic measures are indicated in the form of a cold mitten friction or a cool douche. Care must be taken not to allow the latter to impinge too violently upon the affected joints. The choice of the one or the other must lie with the individual operator and will depend upon the individual case and the means at hand. The after-treatment should be given immediately upon the removal of the apparatus, nor should the joint or limb be allowed to remain in the apparatus after the current is turned off. Ill effects ensue in this way. The part is the seat of an intense local hyperæmia and measures should be taken at once to excite the necessary reaction. Treatment should be given in deep-

seated processes at first daily, then every other day, twice a week and less often as the case progresses.

Both Chemical and Thermal Energy are Active in Concentrated Incandescent Light Energy.—While the chemically active energy of incandescent light spectra is small, still it exists, and there is, therefore, an effect from such penetrant blue-violet frequencies as are present. This is slight as compared with the effect of the thermally active energy as well as the luminous frequencies. The longer waves are fairly abundant and they possess the power of penetrating the deeper layers of the skin. The exact nature of their mode of action is as yet conjectural. It is known that high temperature has a beneficial effect upon ulcerating processes. The irritation of the penetrating long-waved frequencies may stimulate healing and the formation of connective and scar tissues in the same manner as chemical irritants do when applied to sluggish ulcers for the purpose of stimulating granulation tissue formation.

Concentrated Energy of Incandescent Light Spectra in the Treatment of Inflammations of the Mucous Membranes.—The principles involved in the application of light to the treatment of inflammations of the mucous membranes are the same as in any other tissue, skin or glandular, for example. It is simply a matter of utilizing, to the fullest extent possible, the chemical frequencies of light, to overcome the blood stasis, swelling, exudate, pain and impaired function characteristic of the special disease.

Light is applicable to the catarrhal and specific inflammations of the throat, nose and ear, to the inflammations catarrhal, and specific of the pelvic organs, in fact to any mucous membrane to which it can be applied.

By the action of the chemical frequencies of light, both the visible and invisible, tissue reaction is established, with the result of promoting normal circulatory conditions, thereby relieving the blood stasis and of promoting the nutritive activity of cell life. As there is a stimulation of the skin reflexes, when the agent is applied to the skin, so with

mucous membrane contacts a stimulation likewise of their reflexes must result, for the action of the light, as has been shown, is a vigorous irritant to the nervous system.

Both the visible and the invisible chemical frequencies can be used in the treatment of inflammation of the mucous membranes, and the applications may be made locally and also to the entire organism. The use of the invisible chemical frequencies from electric arcs and from spark light is considered in their appropriate place. The visible chemical frequencies can be utilized by means of a diagnostic incandescent lamp of white glass or enclosed in a blue glass bulb, of the highest candle-power permissible for the size of the bulb, which can be carried directly into the nares, the mouth or the ear. Such a lamp can be applied directly to the tonsil itself, it may be attached to the laryngoscopic mirror, and the light directed to the inflamed larynx with beneficial result.

The arc light can also be used in treating the nasal, aural and buccal cavities. With it a profounder influence is obtained, involving greater tissue reaction when topically applied, by reason of the complex chemical frequencies, the invisible as well as the visible. For this purpose, the marine searchlight, as described in the previous chapter with the funnel-shaped attachment, can be adjusted so as to throw the beam of light at its focus, up the nares, in the vagina, or into the mouth and down the throat, the mucous membranes of which have first been rendered anæmic by painting with adrenalin.

In this connection the reader is referred to Pietnikoff's observations considered under the visible chemical frequencies of blue light, and also to the use of the concentrated energy of electric arc spectra in malignant disease of the pelvis discussed in the previous chapter. The use of these means has become one of routine practice with the author and all mucous membrane troubles in patients under care are (1) subjected to the action of light energy in suitable form or (2) to an exhibition of electrical energy either sup-

plementary or alone according to the indication. This is incidental to the general treatment, as the need for the best nutrition and function of the entire organism is after all paramount.

A Water-Cooled Lamp for Gynæcological Work.—The interest in light therapy and the good results obtained from its use in relieving pain and stimulating absorption in a variety of chronic skin conditions, as well as in localized septic conditions, such as blood poisoning from insect bite and inflammation of the labia majoræ prior to pus formation, suggested to the author the desirability of utilizing a water-cooled vaginal lamp in the treatment of chronic diseases of the uterus and appendages.

The lamp shown in Fig. 31 was devised by the writer ten years since for the purpose of demonstrating the possibilities of transillumination of the pelvic tissues and was presented to the American Electro-Therapeutic Association at its fourth annual meeting in 1894.<sup>1</sup> In transilluminating the pelvic tissues it was found that wherever there was morbid material, either in the form of exudative matter pustules or abnormal growths, as fibroid tumors, sarcoma, etc., the tissues were not transilluminated but remained absolutely black. In the absence of these pathological states, the tissues were transilluminated to within two inches of the umbilicus, but nothing was demonstrated other than as above save the course of the blood vessels.

From the experimental work done at that time, the writer was convinced that transillumination of the pelvis was of doubtful utility as an aid to diagnosis, and the lamp was for a time laid aside. Within the past two years it has been taken up, however, and used therapeutically in the author's gynæcological practice. It is a very practical and efficient means of exposing the pelvic organs directly to the influence of incandescent light energy.

The instrument consists of a hard rubber device (it could

---

<sup>1</sup>Transactions, American Electrotherapeutic Association, 1894.



be of blown glass) constructed upon the same principle as the electrode used for vaginal hydro-electric applications. It is provided with an inflow and outflow for the circulating water and also an obturator to close the introitus. The vaginal tube, instead of being fitted with a perforated hard rubber bulb at its distal end, as in the electrode, is provided with a metal socket into which the lamp bulb is fitted, and to which the electric light wires are carried. The handle serves not only for holding the instrument in position but to transmit the wires to the lamp socket. A metal collar with screw threads surrounds the vaginal tube just below the lamp socket. Over the lamp bulb is placed a glass tube, one inch in diameter and  $2\frac{1}{2}$  inches long, perforated at its distal extremity to permit a continuous flow of water around the lamp bulb and into the vagina. At its proximal end, inside is sealed a metal ring. By means of this it is securely screwed into the metal collar on the vaginal tube, making an absolutely water-tight joint.

The lamp now in use requires 32 volts and 8 ampères, giving 8 candle-power. Lamps of less and greater candle-power can be used, and the author has used lamps of even 20 candle-power.

The construction of the instrument is such that it can be rendered absolutely aseptic by immersion in suitable anti-septic solutions.

The lamps are constructed for both a 110-volt direct-current and a 104-volt alternating-current circuit, and can be used with a suitable shunt resistance, or by a series lamp resistance.

The lamp is provided with a very complete shunt resistance by the manufacturers which the author prefers to the series lamp resistance.

With the lamp described all the radiant energy of an incandescent light passing through glass can be utilized. The intense thermal effect is practically eliminated by the passage of water, which is kept not higher than body temperature and often even lower, if no contra-indication exists. There can

be no effect from frequencies above 30 microcentimetres if generated, because of the glass enclosing the lamp filament as well as the glass of the water-cooling tube. The therapeutic value of the frequencies which are permitted to pass, independent of the lower and higher frequencies, which are eliminated in the one instance by the water and in the other by the glass, is practically that of the visible chemical spectrum of incandescent light from which the more intense thermal energy has been eliminated. Recently the author has been provided with lamps for this apparatus, termed cold lamps. They are not strictly cold, but can be used for some moments without water cooling. Care must be taken not to permit too vigorous an inflow of the water. No matter how well constructed there is always the possibility in a water-cooled lamp of a penetration of water into the lamp socket where contact is made.

From the use of this concentrated light energy there was established in four weeks' time in a case of par-ovarian cyst marked relief from the pain and soreness and a diminution of fully one-half in the size of the growth. This diminution was evidently due to the absorption of the fluid contents of the cyst.

A fountain syringe or an irrigating jar is connected with the inflow, while the water drains into a rubber douche pan, placed under the patient into a basin at the foot of the operating table. The minimum of inflow is sufficient to keep the lamp cool. Applications are made daily at first, subsequently three times a week and later less frequently, and from 15 to 20 minutes at a sitting.

It is the writer's belief, based upon clinical experience, that light locally applied has a wide field of usefulness in gynæcological practice.

Photospeculum, an Appliance for Light Energy in Gynæcology.—Makawejew<sup>1</sup> has invented an appliance which is a combination of a vaginal tubular speculum with an in-

---

<sup>1</sup>Russki Vratch, May 3, 1903.

candescence electric lamp that can be used for transmitting the effect of light upon the internal genitals in women. Very good results according to the author have been obtained by the use of light, especially in the treatment of chronic diseases of the uterus and appendages accompanied by neuralgic pains. Applications may be made through the abdomen by means of the ordinary incandescent lamp with a suitable reflector, as electric light does not affect the surface of the body alone, but penetrates into the deeper tissues. Two types of apparatus have been devised by the author in which small lamps can be introduced into the vagina. Their size is such that they do not give off an undue amount of heat.<sup>1</sup>

The first apparatus consists of the ordinary glass speculum, into the distal end of which is inserted a stopper fitting into its lumen, which bears the stem of a small lamp through which the two wires supplying the current are passed. The second appliance consists of two glass tubes shaped like test tubes, one within the other and provided with a metallic collar uniting their open ends. The electrodes leading to the lamp within the inner tube pass through the centre of this collar.

The space between the glass tubes is connected with inflow and outflow tubes, so that a continuous current of water may be maintained around the lamp. The flow of water is maintained at body temperature during applications of from 5 to 20 minutes.

It is believed by Curatulo<sup>2</sup> that dilatation of the capillaries, the direct stimulation of the cells, and the reflex excitement produced in the vaso-motor nerves by the application of light baths will certainly benefit some forms of pelvic diseases.

Curatulo has devised a speculum with which he tests the efficacy of light baths in diseases of women. By means of it the incandescent light energy is divided into its constituent

---

<sup>1</sup>All of these miniature lamps give off considerable heat. The Author.

<sup>2</sup>British Medical Journal, Oct. 11, 1902.

parts. The three kinds of energy, heat, light, and chemical, are isolated and applied separately, or united according to the case. His device also permits the simultaneous use of the liquid douche and the light bath, or the latter may replace the former and act as a hot-air douche.

In cases of metritis, or hypertrophy of the cervix, he believes that an important modification of nutrition may be obtained by moderate application of the chemical rays. In imperfect development of the uterus and the cervix (a frequent cause of sterility), the ability of the chemical rays to improve nutrition should be useful. In perimetritis and para-metritis, conditions which frequently cause uterine displacements, an application of the chemical rays tends to facilitate the absorption of exudations. In uterine inertia the vaginal light bath is useful by reason of its stimulating effect. Curatulo is of the opinion that the germicidal power of the chemical rays will be of value in specific ulcerations of the cervix.

As yet but comparatively little has been done in gynæcological practice, but the vagina and adjacent structures lend themselves to the application of light energy better than other accessible mucous cavities.

Dr. A. I. Orloff,<sup>1</sup> however, seems to have investigated this subject very thoroughly. In a preliminary communication he gives the results obtained in a series of inflammatory conditions of the pelvic tissues from the use of white light. This work begun in November, 1901, covered 50 observations, 38 out-patients and 12 hospital patients. Lamps of from 5 to 16 candle-power were used. The minimum expenditure of energy was made in the beginning of his work, the higher candle-power being used subsequently. Orloff used the apparatus of Makawejew described on a previous page. Orloff's conclusions may be summarized as follows: (1) Light energy is indicated in a considerable number of inflammatory diseases of the uterus and adnexa, such as

---

<sup>1</sup>Ruski, Vrach, Jan. 4, 1903. Phil. Med. Journ., April, 1903.

metritis, parametritis, perimetritis, salpingitis and oophoritis, both in their chronic and especially in their acute forms. (2) The chief and most pronounced action of the light is seen in the amelioration or entire cessation of pain. (3) Under the influence of light exudates and accumulations of pus diminish or disappear entirely. (4) The pain during menstruation (dysmenorrhœa), especially of a spasmodic character, becomes considerably diminished. (5) The pain accompanying posterior flexions of the uterus and nervous affections of the ovaries (neuralgia) is markedly diminished, and after the first application of the treatment it may be possible to restore the uterus to the normal position without any pain. (6) Apparently, erosions of the cervix also yield to this treatment. (7) The amount of leucorrhœa in the uterine cavity and cervix becomes lessened, especially in affections of gonorrhœal origin. (8) Menstruation as well as uterine hemorrhage contra-indicate the application of light. (9) Pregnancy should also serve as a contra-indication in view of our lack of knowledge as to the action of light on that condition. (10) No opportunity was afforded to employ the treatment in cases of tumors. (11) As untoward effects of the treatment may be mentioned the appearance in some patients, after 3 to 4 applications, of general malaise and a feeling of numbness in the extremities, this condition disappearing in 2 to 3 days. (12) The number of treatments required before any improvement in the patient's condition is noticed depends upon the character and the stage of the disease. In Orloff's experience it varied from 8 to 40, each treatment consuming 10 to 20 minutes, repeated daily or every other day. No other form of treatment was employed. The author can corroborate the conclusions of Orloff from a personal experience in the use of light energy in the conditions enumerated.

In view of the fact that Hammer observed experimentally that the movements of the fœtus in utero were excited by the action of light, the condition of pregnancy should be regarded as a contra-indication or at least as one in which

every precaution should be taken. Still, as the continuous current when not interrupted has no untoward action upon the pregnant uterus the author questions whether the chemical action of incandescent light energy would have any untoward effect.

From an exposure of all the pelvic tissues rich in blood supply to the penetrant chemical frequencies of the incandescent light spectrum, a considerable absorption of the light energy must follow. During a 10, 15 or 20 minute exposure, the blood passes and repasses the vaginal tissues until finally the entire blood stream has received its quota of energy. This means increased oxygenating power and the effect is not only local but general. There has been in the author's experience almost an invariable sense of well-being and refreshment following the use of vaginal applications of light. In several instances a sense of general malaise and a feeling of numbness in the extremities has been experienced which has disappeared as noted by Orloff. This has been regarded by the author as an indication that the expenditure of light energy has been (1) too great or (2) continued over too prolonged periods of time. Gautier and Thomson of Odessa,<sup>1</sup> are quoted as having used incandescent light energy in uterine fibromas, para and peri metritis, metritis and thrombic endometritis favorably affecting the symptoms but without any brilliant results.

Sensitization of the Pelvic Tissues.—A more profound and deeper seated action should follow upon the use of suitable sensitizers by painting the mucous membrane with a solution of the same and then applying incandescent light energy. By the preponderance of yellow in incandescent light spectra sensitizers capable of accentuating the action of the yellow frequencies (if such exist as would be applicable), should prove of value. The electric arc light energy carbon or iron or the light of a spark condenser lamp are to be preferred for this purpose, for there are a considerable number of

---

<sup>1</sup>Treatise on Radiotherapy and Phototherapy, edited by Bailliere.

sensitizers upon which the visible and invisible chemical frequencies of light act.

Light Energy in the Treatment of Ozæna.—Dr. Ignazio Dionisio<sup>1</sup> in the experimental treatment of ozæna with light projected it directly, by the aid of reflectors, into the nasal fossæ through the nares, dilated for this end. Both arc light energy and that of incandescent light was used. Sometimes with the former the light was concentrated upon tubes of crystal, introduced into the very fossæ themselves. He has also used little electric lamps, in a bulb and with a circulation of water, introduced directly into the nasal fossæ, or larger lamps, applied in the oral cavity similar to those used to obtain an illumination by transparency of the bones and nasal cavities.

In six cases where the treatment was made regularly, M. Dionisio has observed a remarkable diminution of the crusty secretion and the foetid odor characteristic of ozæna. He does not feel certain as to the permanence of the results.

Light Energy in Otitis Media Purulenta Chronica.—Subsequently Dionisio,<sup>2</sup> following the excellent results which he obtained in more than twenty cases of ozæna, treated by means of light, applied this method in cases of otitis media suppurativa chronica. To this end he employed intense luminous radiations, which he caused to pass through the external auditory canal, into which he had introduced a speculum fixed by a bandage to the head of the patient. In ten cases of otitis media suppurativa foetida in which he ordinarily used, as had been his custom for from 10 to 20 years, deterrent lavage, removal of polypi, antiseptic medications, and cauterizations he applied only the energy of the luminous radiations, following which he had the satisfaction of establishing the cure of four of his patients, after a variable number of from 20 to 40 séances of two hours each.

---

<sup>1</sup>By Dr. Ignazio Dionisio. *Rev. Internat. d'Élec.*, Jan., 1904. *Gazzetta Medica Italiana*. Nov. 6, 1902.

<sup>2</sup>Dr. Ignazio Dionisio. *Rev. Internat. d'Élec.*, Jan., 1904. (Extract from communication made at the 11th section of the 14th Internat. Med. Congress at Madrid, 1903.)

In his other patients there was a very notable diminution of purulent secretions.

Dionisio believes that the curative virtue of the light should be attributed to its antibacteriological power and perhaps also to its exciting action upon the nutrition of the tissues.

The fundamental action is, the author believes, the exciting action upon nutrition. It must not be lost sight of that the bactericidal action of light takes place without, not within living tissue.

Prostatic Hypertrophy.—Gautier<sup>1</sup> reports using the concentrated frequencies of the red region from a lamp of 2 ampères at 110 volts directing the light upon the perineum and inferior abdominal region. He found that this energy exercised a beneficent action upon the hypertrophy of the prostate and the retention of urine. For the relief of the painful symptoms Gautier employed the visible chemical frequencies, only using the same degree of light energy but with a blue glass enclosing bulb. This double benefit, i.e., diminution of the retention of the urine and relief of the spasmodic pains, added to the improvement of the patient's general condition, is usually obtained from the fourth to the eighth sitting. Gautier sums up the method for the cure of hypertrophy of the prostate, as follows: (1) Augmentation of the vesical contraction; (2) rapid disinfection of the bladder as by a septic treatment; (3) micturition less frequent and more abundant; (4) amendment of the pains of micturition.

He regarded the treatment in young patients as worthy of attention, capable of hindering the evolution of prostatitis; with old patients it is to be regarded as a palliative method only, but is of unquestionable value where there does not exist near or distant infection.

---

<sup>1</sup>Revue Internationale d'Électrothérapie.



## CHAPTER XIV.

The Exclusion of All but the Frequencies of the Blue Region of the Spectrum, or the Visible Chemical Frequencies. Blue Light as by the Method of Kaiser and Minim; Its Therapeutic Indications. Contusions, Sprains, Open Wounds and Tuberculosis of Joints.

### Blue Light Energy.

It is easily possible to utilize the visible chemical frequencies of the spectrum, by the use of screens of blue glass. The glass effectually prevents the passage of any of the frequencies of the ultra-violet region, i.e., less than 30 micrometres, and at the same time effectually shields from the frequencies below the blue or the yellow green and red frequencies. The thermal effect is minimized by the blue glass screens, and can still further be excluded by the use of an interposed solution of sulphate of copper. By the exclusion of all but the visible chemical frequencies, blue, indigo, and violet, Kaiser<sup>1</sup> who had observed the favorable action of light on a septic ulcer carried out further experiments, and found that (1) tubercle bacilli in pure cultures were killed in 30 minutes by a powerful blue light arc at a distance of 5 metres, whilst they survived the radiation of an ordinary arc; (2) tubercle bacilli placed on a patient's back, blue light being at the same time directed to the chest at 5 metres for 30 minutes and the procedure repeated in six days, became weakened; (3) pure cultures of tubercle bacilli were killed when exposed to the radiation of an arc concentrated through a hollow lens, containing a solution of alum and methylene blue with ammonia. (4) When the spectrum was

---

<sup>1</sup>British Medical Journal.

split up, cultures lived in red and yellow but were killed from the blue violet to the ultra-violet. (5) Photographic plates attached to patient's back (light being excluded), and the radiation sent through the patient's body, a blurred positive was obtained. Subsequently to these experiments Kaiser treated two cases of advanced phthisis with the same blue light, after six days night sweats ceased and cough became less; at the end of six weeks there was continued diminution in the number of bacilli. In tuberculous abscesses of the thigh healing was obtained in four weeks. In a tuberculous child with weeping eczema cure was established in five weeks. Therefore, in view of the foregoing experiments, Kaiser thinks that blue light kills tubercle bacilli; that chemical rays can pierce the body sufficiently strongly; that blue light acts powerfully as a resolving agent and also as a local sedative; that with a sufficient concentration it may even produce anæsthesia.

In a comparatively recent article from the pen of this observer<sup>1</sup> there is the following detailed account of his experiment to prove the penetration of the visible chemical frequencies and those bordering on the ultra-violet of greater length than 30 microcentimetres, even though these are largely absorbed in passing through the tissues: A medium-sized man was placed in a dark room, and a photographic negative was placed on his back. Over this negative was placed a prepared positive film, the whole being fastened on with plaster. A beam of blue light was then thrown on the thorax (approximately on the front of the thorax notes the translator). A longer or shorter time was required to blacken the film, according as the thorax of the patient was large or small. Then a film only was pasted on, there was produced, after 25 minutes or so, a picture resembling a Roentgen positive, since the blue and violet frequencies penetrate the bones, which have not a rich blood supply, better than other blood rich tissue.

---

<sup>1</sup>Wiener klinische Rundschau, April 19 and 26, 1903. Abs. for Med. Electrology and Radiology, July, 1904.

The arrangement of the mechanisms used by Kaiser in his work cannot fail to be of interest and assistance to the reader. First, he notes that the blue glass of the screen must be carefully tested since most of the blue glass in every day use is unfit for therapeutic use, as it permits the passage of all the frequencies of the spectrum. Kaiser uses a 15 to 30 ampère electric arc light, the carbons of which are arranged horizontally and provided with the usual automatic mechanism. The mechanism, practically much the same as a marine searchlight mechanism, is enclosed in a cylinder, freely movable in all directions, at the back of which a reflector is placed, the end of the cylinder toward the patient being open. Between the light mechanism and the patient stands the blue glass screen for filtering the dispersed light. This is made of strips of blue glass and is practically the same as shown in a preceding chapter. The frame is placed somewhat obliquely to prevent light going through the fissures formed by the strips of blue glass and for the same reason other apertures in the apparatus are filled in with black cloth.

The patient is placed beyond the screen, which can be set higher or lower as required and the beam of light is directed through the glass on to the exposed diseased area for half an hour. In the treatment of deep-seated lesions two concave glasses containing a solution of alum to absorb the thermal energy are placed within the screen in the place of the strips of glass and the diseased structure is brought into the focus of this lens.

Where the lesions are still more deeply seated and a pro-founder effect is desired a concave lens is utilized in the cone of light coming from the lens, thereby producing a more or less concentrated parallel beam of light with consequent shortening of the time required for treatment. Any slight heat felt by the patient is probably due to the yellow frequencies which have not been absorbed by the alum solution. This solution is constantly changed by a special apparatus.

The reflector is placed at just such a distance from the glass strip or lens that it will not crack with the heat. With

a continuous-current 20-ampère arc, this distance is estimated at about 2 metres, while with an alternating current the distance is but three-quarter metre.

Colored spectacles are worn by patients during the exposure to the light energy. Tuberculous diseases of the skin, joints and bones heal with a beautiful white scar. After from 14 to 20 exposures of half an hour each, the exposed area reddens and a scab forms, which in a few days falls off and leaves a beautiful cicatrized place. With deeper seated lesions the progress is slower.

Kaiser finds in common with others using light in tuberculosis pulmonalis that good results ensue, but little resistance being offered by the lungs to the beam of light. In two cases of tuberculosis of the lungs treated, there was noted after a few séances disappearance of the night sweats, improvement of appetite, increase in weight, and a diminution of the bacilli in the sputum, all of which is confirmatory of all other evidence adduced.

Two cases of lupus are detailed here as illustrative of the results to be obtained. All ultra-violet frequencies, of less wave length than 30 microcentimetres, are frankly excluded.

M. E., Lupus Vulgaris of the Nose and Right Cheek for Two Years.—The light was projected upon the part through the blue glass filter or screen. After the exposure there was a distinct reddening which soon became pale and left a strong scab. After the fortieth exposure there was a smooth reddened scar which, after the seventieth treatment, quite harmonized with the color of the surrounding skin.

E. P., Lupus Erythematosus for Four Years.—This had spread over both cheeks and the whole forehead. Prior to coming under Kaiser's care she had been treated by all available methods, but without results. At the time of the report there had been 72 exposures, as a result of which the redness had disappeared, and the patches, especially on the right cheek and forehead, were considerably smaller. The complete healing of the lesion was expected, from appearances, in two months time.

R. P., Tuberculous Ulcer on the Right Forearm for Two Years.—The size was variable, at one time being large, at another small. After 11 exposures the redness and irritation were less, and after 27 exposures a dry scab fell off, and there was complete healing.

Kaiser draws the following conclusions from his experimental and clinical observations :

“(1) Blue light considerably stimulates metabolism. (2) The action is mainly due to the more refrangible rays. (3) It is directly proportional to the distance and intensity of the ray of light. (4) Blue rays penetrate vascular tissue so easily that a deep effect cannot be denied. (5) They have a strong absorbent and anodyne effect, and in a concentrated state are slightly anæsthetic.”<sup>1</sup>

Simply as a matter of interest in the history of the therapeutic use of light it may be mentioned here that Dr. S. Pancoast,<sup>2</sup> of Philadelphia, used blue light, as well as the other frequencies of the spectrum, nearly thirty years ago in his practice, and embodied his views in a curious book entitled “Blue and Red Light.” Detailed cases are reported, and his blue and red rooms with the patient dressed in blue or red reclining upon a couch directly under the sunlight filtered through (1) blue glass window panes entirely, (2) blue and plain glass alternately, (3) red glass entirely, and (4) red and plain glass alternately are illustrated in colors.

The book is a curious one, full of the lore of the ancients, concerning light and its relation to life, as is illustrated by the following paragraph :

“The Kabbala declares that light is the primordial essence of the universe, and that all life and motion proceed from it ; it is the vital dynamic force of nature. It also declares that it is by the study of light that we are enabled to acquire a knowledge of the unknowable or causal world. Light is Jacob’s ladder, by which we ascend to Celestial Knowledge,

---

<sup>1</sup>The author believes that this is not true anæsthesia, but rather one of analgesia.

<sup>2</sup>Blue and Red Light. S. Pancoast.

the upper rundle being in the fourth Septira, represented by the Pentagram."

There is much of the Newtonian philosophy to be found in the ancient literature, and it is suggested by Pancoast that without doubt Newton had been exploring the old mines of Kabbalistic lore and had arrived at his great discoveries by following up clues gained therefrom. Be that as it may, there is no question but that in it there is much which, to the modern physicist, is very suggestive in view of the knowledge of to-day.

But one fact remains to be noted in this connection, viz., that one finds in Pancoast's recorded cases, "Sub-acute Rheumatism," "Sciatica," "Consumption," "Diphtheria with Paraplegia," "Cholera Infantum and Marasmus," "Nerve Exhaustion," etc., the same effects from the action of light with the same satisfactory results as are now obtained. The cases of rheumatism, sciatica, cholera infantum, and marasmus were treated by means of blue light, while the cases of diphtheria and consumption were treated with red light.

The calorific and luminous rays, Pancoast believed, must be excluded in smallpox as pernicious in their effect while the chemical rays were regarded as beneficial in their effect. His conclusion was drawn from the fact that smallpox patients kept in the dark did better than those in the light, showing how unsafe it is to try to deduce a scientific fact from a simple clinical observation.

Minim,<sup>1</sup> who has also especially studied the visible chemical frequencies of the spectrum from the blue to the ultra-violet, considers that they have an action on vaso-motor nerves, that they are endowed with analgesic qualities, and that they ameliorate or cure superficial neuralgias. The physiological action and therapeutic results obtained from the use of blue light is, therefore, due to the visible chemical frequencies. The best results are obtained by exposures to their

---

<sup>1</sup>Dr. A. W. Minim, St. Petersburg, "On the Therapeutic Action of the Blue Electric Light." *The Journal of Physical Therapeutics*, January 15, 1902.

action at a considerable distance from the source of light, showing that the effect is not obtained in any degree from residual thermal energy. His experimental work demonstrated that by the action of the isolated visible frequencies, blood vessels were constricted and marked anæsthesia produced, while the opposite effect was produced by white light. The anæsthesia established by these frequencies, he found to be as marked as that produced by cocaine. In his experience and also in that of others, the degree of anæsthesia produced is sufficient for the performance of minor surgical operations, without pain, and it also facilitates the cicatrization of wounds. Minim first observed the pain-alleviating powers of blue light from using it in pleurisies prior to physical examination, in order to render a tender spot tolerant to investigation. Subsequently he used it instead of cocaine to produce local anæsthesia where incisions and stitching of wounds were required as well as in the treatment of sloughs and in opening abscesses. He also determined experimentally that the action of blue electric light was the reverse of white light, i.e., that a granulating surface became anæmic under the influence of blue light and hyperæmic under the influence of white light. The following two cases are reported by Minim:

(1) Mr. X., a secretary of a foreign embassy, cut his finger with a piece of glass. The cut was on the outer side of the third finger, and about 3 cm. long. After a 10 minutes exposure to the light from a 50 candle-power incandescent lamp, enclosed in a blue glass bulb, two stitches were made without pain. Healing commenced at once, and was completed in four days.

(2) A soldier of the Bodyguard Cavalry Regiment cut the dorsal surface of his left thumb, the wound being about 3 cm. long. After cleansing the wound it was exposed to blue light for 10 minutes, as in the preceding case. Three stitches were then introduced, involving no pain. He was engaged in conversation during the time, and did not attend to what was being done, stating that he thought "a

soft cotton ball was pressed on the wound." On the third day healing had taken place by the first intention. He also found that contusions due to falls were promptly cured by their action.

A case of burn of the first degree yielded to two applications of the visible chemical frequencies from a lamp of 50 candle-power, each exposure 10 minutes in duration.

In a case of injury to the mouth, throat and œsophagus, caused by the accidental ingestion of ammonia, several applications of the blue light accomplished a complete cure. The exposures were made (1) to the mucous membrane of the mouth, and (2) to the front of the neck and chest.

An application of white light, from a 50 candle-power lamp, followed by a few minutes' exposure to blue light from a 25 candle-power lamp, established a cure in a case of rheumatic purpura. In a case of simple purpura, five applications of light cured the patient after other remedial agents had failed. A beneficial effect upon the patients' general health was also obtained. Among the conditions treated by Minim with the visible chemical frequencies, according to his method, may be mentioned burns, hæmaturia, acute myelitis, articular rheumatism and pleuritic pains. Minim finds that bloody effusions are absorbed more quickly when treated at the end of three or four days than immediately after. He observed that the analgesic and absorptive action were greater with blue than with white light. The gradual diminution of the pain and effusion in contusion and ecchymosis is rapid.

Upon examination of a wound treated by means of blue light, punctiform islets are observed to appear upon surface, which rapidly increase, then fuse. The papillæ become rosy, then yellow; the blood which covers the papillæ dries, forming a protecting crust.

Brockbank<sup>1</sup> also reports two cases of minor surgical operations done under blue light anæsthesia. He unfortu-

---

<sup>1</sup>Ultra-violet Ray Anæsthesia in Minor Surgery. *Am. Med.*, April 25, 1903.



nately, however, attributes the action to the ultra-violet frequencies, entitling his report "Ultra-Violet Ray Anæsthesia in Minor Surgery." With the Minim lamp, by reason of its glass enclosure, there are none of the ultra-violet frequencies, as glass is not transparent to them. The frequencies utilized by him and also by Minim are the visible chemical frequencies, i.e., the blue, indigo, violet to the ultra-violet of 30 micro-centimetres in length. The cases reported by Brockbank are of greater severity than those detailed by Minim, and are quoted as illustrative of the analgesic action of light.

Case I.—Suffered from a clean incised wound of the left forearm, extending from the head of the ulna parallel with the bone for two inches, exposing the tendons of the muscles in that region throughout their entire length. The parts were cleansed in the usual manner and then exposed to the rays of light from a No. 4 Minim lamp for 15 minutes, after which 5 interrupted silk sutures were placed without causing the patient any discomfort. The area was dusted with an antiseptic powder, equal parts of urasol and aristol powder, covered with a 10 per cent. iodiform gauze, a compress of absorbent cotton and a small roller bandage. The wound healed without trouble.

Case II.—Fatty tumor just below the left breast. Patient had been advised to have it removed, but had not done so because of her dread of anæsthesia. The site for the operation was thoroughly cleansed, then exposed to the rays of a No. 4 Minim lamp at eight inches for 20 minutes, and at slightly greater distance during removal. An incision two inches long down to the tumor was made without causing sufficient pain to give any distress. Adhesions were then broken up and the tumor shelled out without difficulty. Pressure readily controlled the slight hæmorrhage, and the edges of the wound were brought together by fine interrupted silk sutures without complaint on the part of the patient. The wound was dressed with antiseptic powder, iodoform gauze and compress held in place by adhesive

strips and a roller bandage. No shock, distress, nor discomfort of any kind followed the operation. An examination of the dressings on the second day found them perfectly dry, and on the fourth they were removed. The wound was perfectly healed and the stitches were removed. An iodoform gauze dressing was then applied for two days longer.

Tracy<sup>1</sup> also reports a number of surgical cases in which the anæsthesia was produced by the visible chemical frequencies and healing hastened. He, like Brockbank, wrongly attributes the action to the ultra-violet or invisible chemical frequencies, instead of the blue or visible chemical frequencies.

In one instance a large sebaceous cyst—an inch in diameter—was removed from the scalp without pain under the influence of blue light anæsthesia. The application at distance of two inches was 15 minutes in duration from a No. 3 Minim lamp. Two incisions, each one inch in length, were made and an elliptical piece of skin removed. The cyst was shelled out and four running stitches placed. No pain was experienced, and patient expressed surprise when he saw the tissues removed. A 10 minute exposure, subsequent to operation, was made as an antiseptic precaution. Healing by first intention was established the second day, and on the third the stitches were removed. Complete union did not take place until the fifth day, owing to the formation of a blood-clot underneath the united skin flaps. The parts were exposed daily to blue light for five days.

A subcutaneous abscess involving the distal joint of the thumb was operated on painlessly under the influence of blue light anæsthesia, and recovered completely without bandaging or dressing of any kind, in four days, under daily exposures to the light, the patient going back to his work as a car conductor on the fourth day.

In a skin slough of one inch square and one thirty-second

---

<sup>1</sup>E. A. Tracy: Skin Anæsthesia produced by Actinic (ultra-violet) Rays from Minim's Apparatus, Boston Medical and Surgical Journal.

of an inch deep, due to an injury twenty-four hours previous, of a dirty opaque dark green color, involving the palm of the hand, curettement was made painlessly under blue light anæsthesia. A 10 minutes exposure to the blue light was made immediately after the operation, and an exudate of clear serum was seen to form upon the raw surface. This was wiped off and a piece of cotton compress without any dressing was applied with a bandage. Healing was established in two days save where the cotton had adhered. The removal of the adherent cotton caused bleeding, which ceased and the tissues assumed the characteristic glazed look, as though covered with a thin film of gelatin under exposure to the light. Cotton compress and bandage applied. No further care required. Complete healing.

The removal of the exudate of clear serum from the curetted surface, in the author's opinion, was a mistake. The action of the light had only stimulated the natural process of repair in the first stage, and the chances are if it had not been interfered with that healing would have been established without the adherence of injured tissues to the cotton dressing.

A piece of a broken needle was removed from the forearm painlessly after a 10 minutes exposure to blue light. Tracy states that he has applied blue light several hundred times, witnessing an untoward result in only one instance. This occurred in a case in which the patient's forearm had been burned severely when she was a child. This scar tissue proved very sensitive to the action of the light and following a 20 minutes exposure of the part, a blister formed after 10 hours in no sense different from one produced by a sunburn.

No further complication is reported in this case than the formation of a blister, and that should not in any sense be regarded as an untoward result if it were produced by the chemical energy only. If, however, the thermal energy were active as well, the healing process might be complicated by reason of the two following conditions: (1) Scar tissue is imperfectly organized and nourished as compared with nor-

mal tissue, hence (2) thermal energy would tend to the establishment of an inflammation, which would result disastrously to the integrity of the skin involving the scar tissue. Such would not be the case from the chemical energy. The reaction established might easily be sufficient to cause blistering of the epidermis, but upon its subsidence there would be no destructive action upon the skin and underlying cellular tissue from an exposure of the length specified and from a source no more powerful than a 32 or a 50 candle-power incandescent lamp.

The following case<sup>1</sup> is similar in result to the previous cases, but for it all the energies of a 25 ampère arc were used. As the result obtained in the previous case was by the exclusion of all but the visible chemical frequencies the latter is quoted here to contrast the one method with the other. It seems to be conclusively established that it is the chemical frequencies which are the active part of the spectrum in relieving congestions and inflammations. If the chemical light intensity is not too great there is no need for the exclusion of the ultra-violet.

Mr. G.—March 26, 1904.—Aged 26, has suffered from enlargement of the epididymis, with pain and induration for the past four years. Has grown steadily worse, although under medical care during the past year. Diagnosis Epidymitis. On the day he presented himself for treatment, a high frequency current was applied to the parts, resulting in a very great deal of irritation and discomfort, confining the patient to bed for two days. At his second visit, the beam of parallel rays from the marine searchlight, at full ampèrage (25 ampères), 6 inches in diameter, was projected upon the parts for 15 minutes. The tumor, which at the beginning of the administration, was larger than an almond, was reduced to one-half the size from the one exposure, and all pain and irritation were immediately relieved. The patient did not report for two weeks, because he had no trouble.

---

<sup>1</sup>Dr. W. B. Snow: Personal communication.

The following notes of cases treated by Minim's Blue Electric Light, from June, 1903, to June, 1904,<sup>1</sup> were furnished the author by Dr. H. W. Barnum.

Case I.—Man with greatly swollen hand from bee sting, exposure to a 32 candle-power lamp for half hour at 10 inches, rays falling perpendicularly on the part. The swelling was reduced one half during the treatment and by the next morning was so nearly gone that patient declined further treatment, declaring he was cured.

Case II.—Man with enlarged gland, right groin, skin red. Same treatment as in first case except longer time (45 minutes), daily for a week. Cured. Cause of swelling unknown. At the time he complained of poor health, fearing tuberculosis. He spent the winter of 1903-1904 in Florida and was seen recently in good health.

Case III.—Man with enlarged gland at angle of left lower jaw, caused probably by a decayed tooth. Daily exposures to the blue light energy as above for 30 to 45 minutes. Cured in fifteen days.

Case IV.—Man with pain, swelling, soreness in mastoid process, right side. Earache two months previously, discharge for one day. Muscles stiff and sore, could not turn head nor lie on that side. Blue light as above, 40 minutes daily one week. Cured. Relief was marked after first treatment.

Case V.—Woman with bruise of tibia midway between knee and ankle. The first injury was three years before calling on Dr. Barnum. Had bruised it twice after that. Pain, redness. Blue light for seven days, half hour each day. No trouble since—one year.

Case VI.—Woman with severe bronchitis three weeks. Blue light, three treatments, almost entirely cured. Have treated several similar cases with similar result. Have had good results in chronic bronchitis also.

Case VII.—Woman with severe X ray blister. The blue light used daily undoubtedly hastened healing.

<sup>1</sup>H. W. Barnum, Poughkeepsie, N. Y.: Personal communication.

Dr. Barnum in common with the author has never been able to produce a true anæsthesia by means of the blue light energy.

General Pleasanton, of blue glass fame, claimed to have effected complete cure in a case of contusion by three exposures, each half an hour in duration to the visible chemical frequencies. In view of the preceding reports the correctness of his statement must be regarded as substantiated.

Neuralgia.—In the treatment of neuralgia by means of light energy, Arienzo<sup>1</sup> has used a 30 candle-power incandescent lamp of blue glass provided with an ordinary reflector. The patient was placed 15 centimetres, between 5 and 6 inches, from the source of the light. Exposures were made daily, in 4 cases of neuralgia of the trigeminus, one of the auriculo-temporal and one of the spermatic nerve, all of whom were speedily relieved by the treatment. The cases averaged 10 exposures each save one, in which 20 were made. Arienzo also is of the opinion that the visible chemical frequencies penetrate the tissues and the subjacent organs, and that they have a special action upon the vasa nervorum.

The influence of the Visible Chemical Frequencies or Blue Light upon Catarrhal Inflammations of the Throat.—E. A. Pietnikoff<sup>2</sup> has employed blue light in the treatment of acute catarrhal inflammations of the throat. He reports five such cases with the following results :

(1) The course of the disease was considerably shortened; (2) after the first sitting the action of deglutition became much less painful; (3) the exudate disappeared after the first or at the utmost, the second sitting; (4) the diffuse redness of the mucous membrane disappeared speedily after the second treatment; (5) the swelling of the tonsils diminished markedly after the first sitting, the fever also subsided after the first treatment.

In these cases a 50 candle-power lamp, 110 volts, covered

---

<sup>1</sup>Journal de Medicine de Paris, Jan. 17, 1904.

<sup>2</sup>E. A. Pietnikoff, Bolnitchnaia Gazeta Botkina, Vol. XII., No. 19.

with a blue glass bulb was used. It was placed in the centre of a reflector, at sufficient distance from the patient to prevent any sensation of heat. The light rays should be directed perpendicularly toward the throat and tonsils, and the application made from 10 to 15 minutes. In his cases, Pietnikoff made the application in this way, with slight interruptions during a séance, dependent upon the patient's fatigue from the position necessary. He thus obtained only the visible chemical frequencies.

Action Wrongly Attributed to the Ultra-Violet.—Tracy and Brockbank, in common with many other writers, attribute the action to ultra-violet frequencies. Such is not the case. The patient is effectually shielded from such ultra-violet frequencies as are present in an incandescent lamp, because of its glass covering. Similar results are obtained from the action of white light, and are considered under that head.

Visible as well as Invisible Chemical Light Energy Useful.—These clinical cases, as well as others, indicate the value of the visible chemical frequencies of light as well as the invisible, and show that they have decided therapeutic properties. The experiments of Kaiser, as well as clinical experience, show them to be antiseptic, and also to possess resolvent qualities.

Power of Blue Light to Produce Analgesia.—Their power to produce an analgesia seems to be conclusively proven. A local anæsthesia should as surely follow an expenditure of energy from the chemical end of the spectrum as from an expenditure of energy from a chemical substance topically applied or injected within the tissues. This being the case, the choice lies with the individual operator. It naturally follows that the physician equipped with electric light apparatus, and understanding its value, should use it in preference to other means. Moreover, in addition to this reported ability to produce anæsthesia by this means, there is the additional advantage of the stimulating effect upon the injured tissues, tending to their prompt restora-

tion to the normal. In the author's experience with Minim lamps of 16 to 50 candle-power no such anæsthesia has been produced in the persons of two physicians, i.e., no annulment of sensation, but there was an analgesic condition following the use of blue light. There is, however, every reason to believe both on physical grounds and from clinical observations, that etheric vibrations, whether of the frequency to produce light or an electric current, are capable of analgesic and possibly anæsthetic properties. These observations are a matter of record, with alternating currents of high frequency, and have occurred in the author's experience in the use not only of the chemical frequencies of light energy, but with the current of tension from the secondary of an induction coil, and also from a high frequency of the sinusoidal current. The most interesting and convincing experiments with the sinusoidal current were made by Professor Scripture, of Yale, and reported to the American Association for the Advancement of Science several years since. His experiments were made with a Kennelly alternator. A frequency of 5,000 complete periods per second, 10,000 alterations, was made to traverse a nerve with the result of cutting off sensory communication by this nerve, and needles were run into any part of the body supplied by the nerve without pain being felt. Groups of nerves, for example, the brachial plexus, was cut off in a similar manner. The analgesic and possible anæsthetic effects of currents of high frequency are the same in kind as those produced by light. The agents differ only in rate and wave length.

It is the prolonged applications of these stimuli which renders them tetanizing. Stimuli which are applied at long intervals to the nerve act especially on the vaso-dilator fibres. On the other hand, tetanizing stimuli act on the vasomotor fibres. The latent period of the vaso-dilators is longer, and they are more easily exhausted than the vaso-motors.<sup>1</sup> In

---

<sup>1</sup>Landois and Stirling, Bowditch and Warren, p. 865.



the one instance the active energy should on physical grounds have the proper period of vibrational activity to reëstablish normal atomic motion and also be delivered at intervals, the sudden impulse of an electrical current, for example, while in the latter it is necessary that it should be a rhythmic energy delivered for a prolonged period of time.

Visible Chemical Frequencies Useful in Other Conditions than Surgical.—But the visible chemical frequencies are useful in a great variety of conditions other than those invoking the need of surgical measures, and preceding anæsthesia. By reason of their great penetration and absorption by the blood, in common with the invisible chemical frequencies, they are useful wherever it is desired to control congestion, inflammation even, in all structures within their reach, and they act by their direct oxygenating power.

Not only the pains of burns, open sores, congestions, inflammations, are relieved, but circulatory and absorptive conditions are initiated, resulting in the healing of the former, and the establishment of normal processes in the latter. They act energetically in the removal of ecchymoses following contusions, securing prompt absorption.

While the author uses, as a rule, the entire range of the spectrum from the red and including the ultra-violet, eliminating the heat only, in the class of conditions to be mentioned, others have excluded all but the visible chemical frequencies. The results from the two methods are apparently the same, and the fact that they are obtained without the green, yellow, orange and red, indicates that it is the visible chemical frequencies that are active. This naturally follows from a consideration of their frequency and wave length, i.e., rate of vibrational activity, which influences vibrational activity of molecular structure. It has been pointed out in discussing the physical action of light, that groups of molecules are more probably acted upon than atoms, but there may be an action due to sympathetic resonance or synchronous vibration as well.

But it is fully in accord with known laws to expect an effect from the physical action of light frequencies, even though their period of motion is not in synchronism with that of individual molecules or even groups of molecules.

General Applications of the Visible Chemical Frequencies.—But the action of blue light is by no means confined to localized lesions. If desired, the electric light can be projected upon the entire body through the medium of blue glass. By the use of blue glass in this way, the resultant frequencies are from the visible chemical region, and the action is a chemical one, but less strongly chemical than from the unprotected arc. Still, as has been stated, they are sufficiently active to produce pigmentation of the skin, capillary dilatation and hyperæmia with more complete oxygenation of the blood, as well as a stimulating action upon the organism, through the resultant, chemical, osmotic, and molecular activity which ensues; an effect in kind, but not in degree, of that of the unprotected arc.

The experiments of Pansini point to a special action of blue light, which gives it still further place in therapeutics. From the increased muscular work done under its influence, as demonstrated by ergographic tracings, it should have the power to promote muscular tone in the patient whose tissues are soft and flabby. For the best influence upon the red blood corpuscles, or oxygen carriers of the blood, it is probable that the unprotected arc, rich in ultra-violet frequencies, is the better means, but afterwards, to increase muscle tone, the intervention of blue glass might be desirable. Personally, the author has not so discriminated, but there is the possibility, based upon photo-biological research, that it might be well to so discriminate.

However, by reason of its intense chemical activity and action upon the blood, blue light from a number of incandescent lamps should serve the purpose of a general tonic treatment.

In addition, both experimental evidence and certain clinical data point to an effect upon the nervous system which

is fully considered under that head. The question which remains to be conclusively established is whether better results follow the use of all the energies of an electric arc or whether the exclusion of every activity other than the visible chemical region is desirable in this class of cases. Where it is desired to act directly upon an unduly excitable cerebrum, on theoretical grounds certainly, as well as upon a certain amount of biological research, all but the latter should be excluded.

The Influence of Chemical Light Energy in Precipitating Hysterical Attacks in Anæmic Patients.—The observation has been made by Minim and others that the action of the visible chemical frequencies may either provoke or exaggerate hysteria in anæmic patients. The author has seen one case of neurasthenia with intense spinal irritability associated with extreme weakness of legs, arms and throat, due to the exhaustion of the spinal centres, complicated by a major hysteria, in which all the symptoms were increased for five to six days from an application of the concentrated and condensed chemical frequencies visible and invisible, of five minutes' duration over the sensitive spots, i.e., at the cervical enlargement and the middle of the dorsal region. In this same case an application of the convective discharge from a static machine always excited hysterical manifestations.

Acute Processes Aggravated by an Expenditure of Chemical Light Energy.—Processes characteristic of the conditions which have been enumerated are much more favorably influenced when not of long standing than the more chronic ailments, whether the expenditure of energy comprises the whole of the chemical end of the spectrum—visible and invisible, the visible spectrum only—or white light.

On the other hand, if an acute eruption is exposed to the action of these frequencies, the chances are that the condition will be aggravated, as has been established by Finsen, in the management of smallpox.

The untoward action of these frequencies in acute cutaneous processes, or an acute inflammatory condition elsewhere, is governed by the same laws as an expenditure of any form of energy—electrical or chemical—for example, in the same class of cases.

The use of the continuous current, with its deeply penetrating chemical action, or the topical application of strong chemicals, may in acute processes establish a condition of even greater over-activity of the part. Just so with the chemical end of the spectrum. When it is fully appreciated that one is expending energy capable of profound chemical action, by the use of blue light, its action will not only be much better understood, but savor less of the occult, or as an agent for good by reason of its suggestive influence only. It is not the author's purpose or function to discuss the therapeutic value of the latter method, but great as it is, it is not necessary to use it as an explanation for an influence or condition established by a direct expenditure of chemically active energy.

Summary.—The amassed clinical evidence points to an action upon the vaso-motor nerves. (1) The first action seems to be a vaso-constriction. This is probable, as the first impingement of an electric current from the continuous on up the scale, invariably acts to produce a vaso-motor constriction primarily, the dilatation and equalization of the circulation following in the order given. In this way the tissues are rendered anæmic; and (2) an anæmia tends to an analgesia and possibly anæsthesia. When too long an application or exposure a hyperæmia results; (3) by the use of blue light a soothing effect is produced on the nerves. It is quieting and von Jaksch<sup>1</sup> emphasizes the soothing soporific effect of blue light and uses blue glass chimneys upon lamps in his sick wards; (4) by its use healing of wounds is promoted; (5) exposure to blue light energy increases the power to do muscular work (Pansini).

The Minim Lamp.—In order to bring the visible chemi-

---

<sup>1</sup>XX. Congress f. innere Medicine, 1902.

cal frequencies of light within the reach of the general practitioner, Minim devised the arrangement of light mechanism bearing his name. It is inexpensive and portable, but not superior, as has been claimed, to the original arrangement of arc light mechanisms used by Finsen, or the many other arc light mechanisms in use both in this country and Europe. They are, to a certain extent, interchangeable in their uses, but the Minim lamp can in no sense take the place of the arc lamp, not alone because of the glass enclosure, limiting thereby the ultra-violet frequencies, but because the quantity

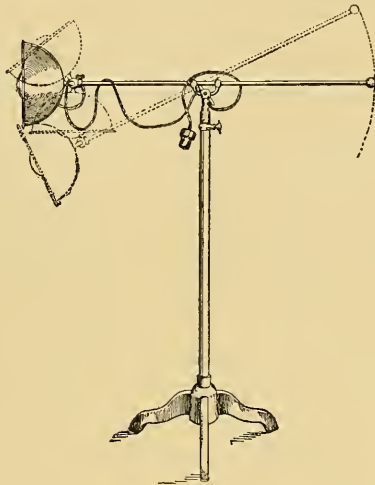

Fig. 32.

of light is absolutely inefficient in the deeper seated, longer standing, and more fully organized morbid processes. It is one thing to secure brilliant results in the production of anæsthesia in limited areas, the perfect sepsis and healing of superficial wounds, the relief of pain in recently injured joints, but it is a different matter to successfully combat or modify more extensive and profound pathologic states, for example, the deeply infiltrated and indurated tissues of old lupus cases, pulmonary tuberculosis, spinal cord lesions, as in locomotor ataxia. Here it becomes a matter of a much

greater expenditure of energy than is possible with an incandescent lamp. The greater the expenditure, the more profound the influence, and to that end the more powerful sources of light, as the electric arc, should be used. And in the event of the visible chemical frequencies alone being desired from the arc, the light should be projected through the media of a blue glass screen.

The apparatus (see Fig. 32) consists of a stand similar to those used for the crown electrode of a static machine, into which can be fitted at will one of the three incandescent blue glass bulbs, 16, 32 and 50 candle-power, and known as lamps Nos. 1, 2, and 3, respectively. Each of these bulbs is provided with an aluminum reflector, ranging from  $6\frac{1}{2}$  to 9 inches in diameter.

In addition there is a ground-glass bulb used for frictional applications to a part.

The reflector is adjusted to the stand, as shown in Fig. 32. The lamp socket is pushed into the opening of the reflector, to which it is securely held by clamps, and whichever lamp the operator desires to use is screwed into the socket at the base of the reflector.

The plug in the end of the cord is screwed into an electric current socket. Either the direct or alternating current can be used according to the source of the E. M. F. with which the physician's offices or patient's house is equipped. The bulbs for these different currents are not interchangeable, owing to their different construction.

The reflector serves to project the rays of light upon the part to be treated, and by means of it it is possible to utilize the maximum energy of the visible chemical region which can be obtained from the source of light in question. No reflector is used with the ground-glass bulb.

Technique of the Minim Method.—Minim has formulated the following technique for the use of the method known by his name: (1) The rays must fall directly on the part to be treated, and not at right angles thereto. (2) The reflector containing the lamp bulb should be adjusted at such

a distance that the patient will perceive a feeble sensation of heat. (3) Daily exposures of the affected part should be made, from 10 to 15 minutes each, or from 25 to 30 minutes every other day. If severe itching of the skin occurs, treatment should be omitted for at least two days. (4) If there is pain in the parts to be treated, the skin should be washed before the exposure with equal parts of alcohol and a one per cent. boric-acid solution. Should there be no pain, then the alcohol should be used alone. When a joint or muscle has been treated by means of the blue light, then the part should be gently rubbed with the ground-glass lamp. The rapidity of movement is governed by the condition of the parts as to tenderness.

While these are the rules laid down by Minim, the individual operator will modify according to the individual case. The use of the alcohol, in the author's opinion, simply serves to make the skin more susceptible to the vibrational activity of the light.

Given an equipment of which the electric arc forms a part, the author prefers it to the lesser energy of the incandescent lamp; but as the rank and file of the profession may, if they desire, avail themselves of the latter when they could not of the former, it is commended to their attention.

In the ground-glass lamp, as used in the Minim method, the intense thermal activities are modified, and there remain the frequencies from the red to the edge of the ultra-violet, or white light.

By its use in connection with the blue light, the cutaneous circulation of any part of the body exposed to the light activities is stimulated, metabolism and absorption are promoted and not only local nutrition, but general nutritive activity is favored. While in any given local lesion the best result is secured by a general as well as local exposure, still the influence of the latter extends far beyond the bounds of the immediate area acted upon. Not only is pain relieved by the effect upon the peripheral nerve endings, but an anæsthesia sufficient for minor surgical measures is produced as well.

## CHAPTER XV.

The Non-Concentrated Frequencies of the Red Region of the Spectrum or Red Light. Exclusion of all Above the Red in Smallpox and the Exanthemata. Finsen.

### Red Light Energy.

Exclusion of All Light Energy Save the Frequencies of the Red Region of the Spectrum as a Preventative Measure in Smallpox and the Exanthemata—Introduction.—Red light is not only valuable in the treatment of smallpox but of measles and scarlet fever as well. It is here by the absence of the intensely actively chemical energy that good results. Still, it must be recognized that all the visible frequencies are, to a greater or less extent, chemically active; but it is the short and high frequencies of the greatest refrangibility which act chemically in relation to the skin.

Were red light synonymous with heat, it would be contraindicated in such febrile conditions as smallpox, scarlet fever, measles, etc., for the organism would not bear the prolonged application of a greater heat under such conditions. There would unquestionably be established a thermostasis or retention of heat which would result unfavorably.

Finsen is authority for the statement "that no ray of light should ever be allowed to fall on a smallpox patient unless it has passed through something red." The theory advanced by him is that red light in smallpox does not act as such, but by the exclusion of the chemical frequencies, especially the ultra-violet. By a series of experiments he proved that if the chemical frequencies are intercepted the remaining rays are innocuous and that a smallpox patient may be exposed to them a whole day long without evil conse-



quences. Schamberg<sup>1</sup> controverts this view, but as his statistics comprise only two cases in addition to his theoretical considerations they cannot in any sense be regarded as conclusive. The exclusion of the chemical frequencies is not only an extremely rational theory but one supported by much and very conclusive experimental evidence as well as 150 cases successfully treated in this way. Schamberg believes that it is impossible for diffuse winter daylight to have any irritating effect upon the skin. He also believes that the eruption of smallpox has a greater predilection for the face and extremities by reason of their great vascularity. He reasons that if the theory of Finsen is correct, negroes should suffer less from pitting than the white, because of the pigmentation of the skin, and therefore the inability of the chemical frequencies to penetrate and cause irritation. In his opinion, the vaccinal condition governs the result, not the exclusion of the chemical frequencies of light. In this view the author does not concur. The physical action of the penetrant chemical activities upon the blood stream, in addition to much experimental work and therapeutical result, all very clearly point to the chemical frequencies of light as the causative factor in the severe inflammation of the skin, involving cellular tissue, characterizing not only smallpox but erysipelas. When it is considered that a 5-minute application of concentrated light energy from a 17-ampère arc, used with but one-third of the controlling resistance, from which the heat is filtered out, will produce in 20 minutes a redness extending over an area the size of the compressing lens, which increases in severity of reaction, i.e., sense of burning, as though the part had been blistered as well as in intensity of coloring, for 24 hours or more, it is not possible to hold any other opinion.

Historical.—The views of Finsen with reference to the employment of the red frequencies in smallpox have been disseminated and discussed during the past few years.

---

<sup>1</sup>Schamberg, J. F.: The Journal of the American Medical Association, May 2, 1903.

During his researches into the action of the chemical frequencies upon the skin, Finsen chanced upon a pamphlet in the medical library at Copenhagen, published in 1832 by Dr. Picton of New Orleans. In the pamphlet was the accidental mention of the fact that, during a certain epidemic of smallpox, some soldiers confined in dark dungeons had suffered the disease and recovered without suppuration or scarring. No explanation of the phenomenon was made, but to Finsen, whose experimental work had shown him so clearly the nature of the action of the chemical frequencies upon the skin, the explanation came as quickly and vividly as a lightning flash. The soldiers in question had recovered without scarring simply because being in dark cells they were protected against the action of the irritating chemical activities. Although he had never seen a case of smallpox, he came to the conclusion entirely on theoretical grounds that exclusion of all but the red frequencies would effectually prevent scarring and pitting, and presented within a month after the question suggested itself to him his red light treatment of smallpox. The red light treatment of smallpox had been successfully practised before in the popular medical practice of centuries past and according to Finsen<sup>1</sup> the face and hands of smallpox patients in China, Japan and Roumania were swathed in red cloth and graver symptoms averted. It was also practised in England several centuries ago.

John of Gaddesden,<sup>2</sup> who wrote the famous medical treatise, the earliest in the English language, "*Rosa Medicinæ*," and who died in 1361, treated the son of King Edward I. for smallpox by covering him with scarlet blankets and a red counterpane, placing him in a room in a bed with scarlet hangings, gargling his throat with mulberry wine, and having him suck the juice of red pomegranates, and the patient recovered, never showing any trace of smallpox.

---

<sup>1</sup>Ueber die Bedeutung der chem. Strahlen des Lichtes, etc., Leipzig, 1899.

<sup>2</sup>Philadelphia Medical Journal, Dec. 7, 1901.

Such, says Gregory, writing in 1843, was the boasted prescription of John of Gaddesden, who took no small credit to himself for bringing his royal patient through the disease. Also back in the time of Queen Elizabeth, the value of red curtains, red coverlets and red glass about the bed in small-pox cases was loudly proclaimed by certain doctors, who were regarded, as was John of Gaddesden, as charlatans by the orthodox physicians of the day. There is also some evidence that other physicians in different times and places have believed in the virtues of phototherapy and adopted it to cure certain forms of skin disease.

In 1867 Black<sup>1</sup> revived the question of the influence of light in smallpox, claiming that the complete exclusion of light, even in unvaccinated cases, effectually prevented the pitting of the face. In 1871 Waters<sup>2</sup> stated that by the exclusion of daylight there was no doubt but that the disease was less severe; while Barlow<sup>3</sup> observed that there was a marked contrast between the conditions of the two sides of the patient's face, one of which was covered with a colored gelatin to exclude the chemical rays of the sun, while the other was exposed.

The author, however, has never chanced upon any scientific explanation based upon experimental work for the exclusion of all the frequencies above the red, prior to that given by Finsen himself.

Therapeutic Results.—At the time of Finsen's solution of the question, it happened that there was much smallpox in Bergen, Norway, and Dr. Lindholm, Chief of the Military Service, suggested to Svendsen,<sup>4</sup> his assistant, that he make a trial of the red light treatment. The first test was made in August, 1893, on 8 smallpox patients, 4 of them children, who had never been vaccinated and were bad cases. Almost all presented some confluent vesicles on the face and hands. The results substantiated Finsen's theory and was summed

<sup>1</sup>Lancet, June 29, 1867.

<sup>2</sup>Lancet, Feb. 4, 1871.

<sup>3</sup>Lancet, July 1, 1871.

<sup>4</sup>Hospital stidende, Sept. 6, 1893.

up by Svendsen as follows: "The period of suppuration, the most dangerous and most painful stage of smallpox, did not appear; there was no elevation of temperature and no œdema. The patients entered the stage of convalescence immediately after the stage of vesiculation, which seemed a little prolonged. The hideous scars were avoided."<sup>1</sup> Svendsen practised also on two patients a most illustrative experiment. They presented upon the face some vesicles withered by the red light treatment, but their hands were covered with vesicles still in activity. Now these patients exposed to the sun presented no modification upon the face, while the vesicles of the hands ended in suppuration. A few months later Dr. Benckert<sup>2</sup> of Gothenburg, Sweden, tried the red light, stating subsequently as the result of his experience, that in grave cases of smallpox it gave the most surprising results, that suppuration was usually abolished, scars extremely rare, and if they do occur are insignificant, the duration of the disease is also shorter.

Montague L. B. Rood,<sup>3</sup> surgeon in the Royal Navy, used the red light preventative measure in 1897, the results surpassing his highest expectations. The following report was made by him: "A blue jacket was received on board a gunboat I was then serving in from the flagship on the China station at a port in Corea for passage to hospital at Nagasaki. His temperature was 103 degrees, rapid pulse, furred tongue, headache, and the patient very ill. He was in the second week of the disease, but suppuration was slight. There was an abundant eruption over the face, scalp, back of the hands, and a less abundant eruption over the trunk and limbs. He was placed under the forecandle in a swing cot, and enclosed with a canvas screen. The only light was supplied by two scuttles, which were covered with thick "red bunting" (used for making flags). He was treated in the usual way with liquid diet and tepid sponging. In two days

<sup>1</sup>Medicinsk Rev., Oct., 1896.

<sup>2</sup>Contribution to the study of phototherapy, Thèse, Lyon, 1900. Bayle.

<sup>3</sup>British Medical Journal, Dec. 5, 1903.

the temperature had fallen to 99°, and there was a very marked effect on the eruption, and his general condition much improved. He made a rapid and uninterrupted recovery, although the light preventative measure was not carried out after he was placed in hospital at Nagasaki. There is nothing new in this communication, but is one more positive proof of the efficacy of this light treatment, and it may help others in a similar position to try it."

It is difficult to appreciate at this time both the horrors presented by the constant presence of smallpox and the very grave disfigurements following it, before the custom of immunization prevailed. In most countries the custom of vaccination prevails. This is not true in Egypt, and Engel<sup>1</sup> found there ample opportunity for collecting pathologic and therapeutic knowledge from thoroughly typical cases. He had the opportunity of testing Finsen's method in a small but severe epidemic in Cairo and vicinity. The epidemic was stopped by wholesale vaccination.

Twenty-five cases only, but all of a severe type, could be dealt with in the pavilion arranged to carry out the treatment, according to the method of Finsen. Four (or five) cases ended fatally. In another pavilion all the other cases were treated and showed a nearly equal mortality. Engel regarded the number of cases as entirely too small to give a reliable comparison of statistic averages. However, it was clearly shown that the red light treatment did not seem to have any influence on the appearance of the rash, save that the hemorrhagic variety was never seen. The good effect was very evident, when the rash had already appeared, save in the case of mucous membranes.

In recent eruptions the formation of pustules was interrupted, in slight cases pustulation prevented, and in severe cases the severity and duration were considerably mitigated. No lasting or serious complications occurred and no deep radiating loss of tissue even in confluent cases. In the four

---

<sup>1</sup>Engel: "Therapy of the Present Day," May, 1901.

typical cases in which death occurred the throat, upper air passages and bronchi were very severely affected, the condition being accompanied by high temperature. As a rule, the exclusion of the chemical frequencies exercised a beneficial influence, unless the mucous membranes were affected. The secondary fever, depending more or less upon the inflammation of the mucous membranes, is always a very dangerous symptom. Multiple vaccination, i.e., in more than one spot, did not seem to exercise any better protective influence than single vaccination.

The consensus of opinion is that this method results in the total or partial suppression of suppuration and its concomitant fever, and the absence of scarring. Such scars as are left are mostly only superficial smooth hyperæmic patches which clear away later. There is no deep spreading loss of substance, but at most shallow depressions. As severe ulcers of the skin were avoided there were no resultant serious general symptoms. The complete exclusion of light or darkness acts in the same way as red light; for with darkness as with red light the chemical rays are excluded.

A Possible Action of the Red Frequencies.—Freund believes that it does not follow that the red rays do not play an active part in this therapy. It does not, he says, seem improbable, when considering the action of the allied thermal frequencies, that the red frequencies too should have a beneficial effect. Engel's observation that the red light treatment of smallpox patients had no effect upon the mucous membranes of the upper air passages, that is, parts which are usually in darkness, supports his theory. The upper air passages are deeply situated in the surrounding tissues and do not readily permit of transillumination. A good test for the theory advanced by Freund that the red light may play an active part in this therapy, would be to utilize in so far as practicable lamps so placed as to expose these tissues directly and constantly to red light energy. If under the influence of transmitted red light better results were secured it would be evidence in support of his theory.

The author believes, however, that red light does not act as such in smallpox and the exanthemata but by the exclusion of the chemical frequencies.

Suppuration of the Vesicles Due to the Chemical Frequencies of Light.—In a comparatively recent article Finsen emphasizes the statement that it may be considered an irrefutable fact that daylight, and especially the chemical frequencies, have a most injurious effect on the course of smallpox, as the suppuration of the vesicles is due to the action of light. It is possible therefore to avoid the suppuration and its disastrous consequences by protecting the patients from the action of light. On the other hand there is no action by light on the smallpox infection itself, and death caused by the latter cannot be prevented by excluding the chemical rays; but the avoidance of suppuration is of the greatest importance, as the suppurative stage is most dangerous, and the greatest number of deaths is due to this process.

Further, the numerous complications and sequelæ due to suppuration may be avoided, as well as the disfiguring by pitting.

Since smallpox is a disease for which the public health authorities oblige the patient to go into a particular hospital, he has a right to ask that there he shall not be unnecessarily exposed to dangers that may be fatal, or at least liable to disfigure him for life.

It must, concludes Finsen, be considered absolutely unwarrantable on the part of the public health authorities to treat serious cases of smallpox in which suppuration might be expected in hospitals where patients are exposed to daylight. As to the private physician, it must be considered a gross shortcoming if, as soon as he diagnoses smallpox, he does not make preparations to prevent the patient from being exposed to daylight. Everywhere it is possible to darken the windows by curtains, and all the necessary light can be supplied by a candle.<sup>1</sup>

<sup>1</sup>The British Medical Journal, June 6, 1903.

Finsen's Technique.—In July, 1893, Finsen first treated acute exanthemata by the exclusion of all the energy of the spectrum above the red from the rooms occupied by them, filtering the light through thick red curtains or screens.

The following conclusions in relation to this matter are from Finsen's pen, and should be carefully weighed by every one using the method.

“(1) The exclusion of the chemical rays must be absolute. The thickness of the red material employed to filter the light depends upon its nature. If paper or thin cotton cloth is used, four or five layers may be sufficient. If quite thick woollen cloth or flannel, two or three layers will answer. It is easier to employ red glass, but in this event the glass must be very dark. In other words, it is necessary to protect the variola patient with as much care against the chemical rays as the photographer does his plates and paper. As to artificial light it is necessary not to use either electric light or any sort of light that is very brilliant. The globes and chimneys of lamps ought to be very dark. A wax candle is permitted because of its feeble light. It can serve for the examination of the patient and to light him at his meals.

“(2) The treatment must be continued without any interruption even to the complete drying of the vesicles. Even a short exposure to the daylight can produce suppuration with its sequelæ. It is then absolutely necessary to prevent the penetration of the light, for example by nailing the curtains securely that the patients and attendants who are annoyed at being in the semi-darkness may not open them and reduce thus to a nullity the good results hoped for by the treatment.

“(3) It is necessary to give the treatment as soon as possible from the appearance of the eruption, for the nearer the approach to suppuration, the more the chance of obtaining a good result diminishes.

“(4) This method does not exclude but permits all other treatment that the physician judges suitable.



“(5) Of course death from variola is not prevented by this treatment, above all before the period of supuration.

“(6) If the patients are submitted in time to this treatment and if the above rules are followed, supuration would often be prevented and the patient recover without cicatrices, or only with some few rare cicatrices, which are almost invisible. It is well to note that for six or seven weeks the skin remains covered with hyperæmic or pigmented spots. At the end of this time they disappear.”

Exclusion of the Chemical Effective Energy.—This is sometimes termed a negative phototherapy. Finsen has raised it to a precise and scientific method for which he has formulated with care all rules. There is then no reason why it may not be scientifically followed in hospitals devoted to the care of these patients. There is a great mass of evidence upon this subject. In addition to those mentioned are Juhel, Strandgaard, Feilberg, Rinoy, Perounet, Oettinger, Moore, Krohm and Mygind of Denmark, Doel of Bergen, Backmann and Courmant of Lyons.

The latter formulates the objection that it is difficult to say that the room can be so perfectly free from chemically active energy that a photographer's plates would not be acted upon; and also that the treatment is extremely painful both for the attendant and the patients who presented a state of continual super-excitation.

Bayle<sup>1</sup> apropos of this notes the fact that at the Maison Lumière where photographic plates and papers are prepared and which was formerly lighted by a red light, because of the intense cerebral excitation on the part of the workmen, green was substituted for the red, when the cerebral phenomena ceased. The properties of the green in this relation are similar to those of the red. For the same reason it is recommended that green be substituted for the red as a preventative measure in smallpox.

---

<sup>1</sup>Loc. cit.

The Exclusion of the Chemical Frequencies in Measles.—Chatinère,<sup>1</sup> Backmann,<sup>2</sup> and Schüler,<sup>3</sup> were induced from the results obtained in smallpox to try the same method in measles.

In this disease the treatment was also successful. The hyperæmia was lessened and the laryngeal and bronchial symptoms improved. Schouli,<sup>4</sup> Festner<sup>5</sup> and Schüler,<sup>6</sup> report good results from the use of the same method in scarlet fever and erysipelas; the course of the illness being modified in duration and severity.

Schouli<sup>7</sup> has reported six cases of scarlet fever in which red light has been used as a preventative measure. Two were instanced prior to the report quoted from. The first of the remaining group of four was placed in the red room from the beginning of the eruption where he remained five days. The course of the disease was benign, uncomplicated, no albuminuria and at the end of the five days the eruption had totally disappeared, without a trace of desquamation.

The second case, aged 5 years, was "very spoiled" and his parents could keep him in the red room but two days. Desquamation was not prevented. In the third case the patient was only placed in the red room on the third day of an intense scarlatinal eruption. Because of this delay, despite the four days passed in the red room, there was a slight desquamation upon the abdomen, hands and feet. But this desquamation was less intense than usual, furfuraceous upon the trunk and very small scales elsewhere. The fourth patient reported showed the happy effect of the exclusion of light energy above the red the most satisfac-

---

<sup>1</sup>La Presse Medic., 1898, No. 75.

<sup>2</sup>Quoted by Bie, Mitteilungen aus Finsen's Lichtinst., II., p. 150.

<sup>3</sup>Ibid.

<sup>4</sup>Refer. Zeitschr. f. diät. u. Phys. Th., Vol. III., p. 612.

<sup>5</sup>Quoted by Bie, Behandlung von Masern u. Scharlach mit Ausschl. d. sog. chem. Lichtstrahlen Mitt. aus Finsen's Lichtinst., II., p. 146.

<sup>6</sup>München med. Wochenschr., 1901, April 1.

<sup>7</sup>Phototherapy of Scarlet Fever, Analyzed in Bull. Med. Nov. 24, 1902. Journal de Physiothérapie, Jan. 15, 1903.

torily of the group. The child was placed in the red room on the first day of the eruption, where he lived for six days. There was absolutely no desquamation.

The advantages of preventing desquamation are: (1) Diminished duration of the disease; (2) a lessened severity of the disease in its later stages; (3) above all the diminished contagiousness.

The Exclusion of the Chemical Frequencies in Erysipelas.—A member of the Dermatological Society of Chicago, who has used red light in the treatment of measles and erysipelas, reports negative results. On the other hand Krukenberg,<sup>1</sup> who reports 18 cases of erysipelas, states that the fall in temperature and the general amelioration of the symptoms were unquestionably due to the exclusion of the chemical frequencies. He is also of the opinion that the favorable action obtained from the use of ichthyol, of tincture of iodine, as well as various plasters, is due, in part, at least, to the protection insured the part from the action of the chemical frequencies. By reason of the pigmentation of his skin, the negro is protected from the action of these frequencies; and according to Däubler and Plehn, is much less susceptible to erysipelatos and phlegmonous inflammation.

Exclusion of the Chemical Frequencies in Operation for Peritonitis.—It has been suggested by Clinton<sup>2</sup> that the exclusion of chemical rays, during operation for general peritonitis, might insure a better result from operative measures in general peritonitis. He calls attention to the fact that many patients succumb, whose condition prior to operation does not indicate the gravity which the case assumes after operation. When opened, washed and drained, they promptly drop into a state of septic collapse, from which they do not rally. The effect of the operation suggests that a severe infection has been stimulated in a severe manner. He asks what is known of the necessity for the presence of sunlight in the development of bacteria. It is his belief that strepto-

---

<sup>1</sup>Munich Medical Wochenschrift.

<sup>2</sup>Annals of Surgery.

coccus infection of the skin will not occur in the absence of sunlight or active rays. This is seen in smallpox, where the secondary pustular period will not develop if actinic rays be absolutely excluded from the patient. He regards the analogy between this condition and acute general peritonitis apparently as strong as between the curing of lupus and tubercular peritonitis by sunlight.

It has been demonstrated by Finsen that the pustulation of smallpox is due to the stimulation of the secondary streptococcic infection by the actinic rays. In the analogy which seems to exist between smallpox and general peritonitis, Clinton suggests that such cases should be operated upon in operating room or amphitheatre, from which the chemical frequencies of light were excluded by the use of red glass globes enclosing the electric lamp bulb. This suggestion has not to the author's knowledge been acted upon by any one. It would be interesting to utilize the suggestion in the surgical ward of some hospital where a sufficient number of cases could be so treated as to make the observation conclusive.

The Results of the Red Light Treatment in Smallpox Dependent upon Careful Technique.—The results obtained by the red light treatment of smallpox depend very largely, in fact, almost entirely, upon the thoroughness with which it is carried out. Even a trace of daylight is sufficient to unfavorably influence the result. In the early history of the method control tests were made showing that if smallpox patients were exposed to daylight after beginning the red light treatment, they invariably suffered suppuration and scarring.

The inflamed skin is as sensitive to the chemical frequencies as a photographic plate upon which radiant and oscillating energy meet cessation, for the waves in doing their work on particles of silver leave their record and come to rest. Just so upon the acutely inflamed skin, save that in doing their work, i.e., dilating capillaries producing hyperæmia and more acute inflammation even, they intensify

suppurative processes, and from the cosmetic point of view at least, in this condition do very great damage.

In arranging rooms or pavilions for the treatment of smallpox every window and opening must contain red glass or be covered with red curtains, and the same care must be taken as by the photographer in guarding his dark room. Such a room when arranged should be examined spectroscopically in order to know beyond a question that all but the red frequencies are excluded. In ordinary cases a clear red light is found to be sufficient to prevent scarring, but in very bad cases, however, there is need of a deep red light.

The Classic Measure of Painting the Face with Silver Nitrate or Smearing with Fats Valuable by Exclusion of Chemical Frequencies Most Extensively Active.—The measures which for many years have been found to secure the best results in smallpox—so far as the skin lesions are concerned, have no doubt been valuable by excluding to a certain extent the chemical frequencies, and thereby protecting the skin. In the painting of the face with nitrate of silver, for example, the silver salts served for the fixation of the chemical frequencies, preventing any further work upon their part. The smearing of the face with fatty substances may be explained in the same way, as Hartley and Huntington,<sup>1</sup> by their experiments showed that the normal fatty acids have a stronger absorptive power for the refractive rays of the ultra-violet region than the corresponding alcohols, and that increase in this absorptive power in this part of the spectrum is correlated with increase in the number of  $\text{CH}_2$  groups in the molecule of the homologous alcohols and acids.

Still further investigations, involving a consideration of the relationship between the absorption spectra of carbon compounds and their molecular structure, established the fact that the fatty acids absorb those rays to a greater extent than do the corresponding alcohols. Iodine also used for the same purpose should be less effectual, as the vapor of iodine

<sup>1</sup>Landauer, p. 182.

which transmits the red, transmits the blue also, retarding the red even more than the blue.

In the author's experience with scarlet fever the best results have been obtained where the skin of the entire body has been protected with a carbolated glycerin. The glycerin must have served to protect the skin from the chemical light energy.

Red Light in Other Skin Diseases.—Winternitz<sup>1</sup> is authority for the statement that red light acts favorably in various skin diseases, having used it in such a way as to avoid heat and its resultant sudatory action. By covering up with red materials the parts of the body exposed to the sun, he diminished hyperæmias of the skin and cured eczema. The action obtained was doubtless due to the absence of the chemical activities, not to any specific action of the red frequencies just as in the treatment of smallpox and the exanthemata. He also brought about distinct improvement in cases of chronic rheumatic affections of the joints, hands and feet in the same manner.

Freund<sup>2</sup> entertains the opinion that long exposures of diffused red light favorably influences localized skin conditions, as acne vulgaris, ulcers of the legs, etc. The author has found, however, that acne vulgaris is favorably influenced by exposure to the chemical frequencies of light, and believes in these conditions, as well as similar ones, that the chemical frequencies concentrated and localized are preferably indicated.

In 1887, Th. Veiel<sup>3</sup> cured a violently and persistently recurring eczema solare in the case of a lady by directing the use of red silk veils. This seems to have been the first experiment on a scientific basis with colored light.

Unna,<sup>4</sup> Wolters<sup>5</sup> and Berliner<sup>6</sup> reported similarly good

---

<sup>1</sup>22 offentl. Vers d. balneol. Gesellsch., Berlin, May 7-12, 1901.

<sup>2</sup>Freund: Radiotherapy.

<sup>3</sup>Vierteljahrsh. f. Derm. und Syph., 1897, p. 1113.

<sup>4</sup>Monatsh. f. prakt. Derm., 1885, Vol. IV., p. 277.

<sup>5</sup>Ergänzungsb. z. Archiv. f. Derm. und Syph., 1892, I. p. 187.

<sup>6</sup>Ibid., 1890, Vol. XI., Nos. 10 and 11.

results in 1892. Instead of the red light filters Unna and Berliner used yellow (colored with curcuma) masks and veils and windows.

There are many observations pointing to the active part played by the longer, slower and less refrangible frequencies of light. These have been considered at some length in connection with the physiological action of light.

The physical fact remains that they have a stronger chemical effect upon certain substances than the shorter, higher and more refrangible frequencies. These are instanced upon page 306:

There is also a certain antagonism between the actions of the energy of these different parts of the spectrum. Certain effects of the blue and violet frequencies are neutralized by the red frequencies. It was observed by Herschel<sup>1</sup> as long ago as 1830 that the energy of the red region produced an opposite effect from that of the blue upon certain photographic papers. The so-called negative effect of certain light rays has been very precisely described by Fizeau<sup>2</sup> and Foucault.<sup>3</sup> In 1847 Claudet<sup>4</sup> demonstrated that the energy of the red and yellow regions served to check the action of the others, especially the energy of the blue on bromid, iodid or chlorid of silver. If it had already taken place it was reversed upon exposure to the red and yellow. He observed later that red and yellow light always acted negatively or destructively on bromo-iodid or bromo-chlorid plates. On iodid of silver plates they sometimes acted negatively, and sometimes the same way as blue.

Claudet studied the negative action of the energy of the single frequencies. He found that in order to reverse the action of white light that has acted for the time unit 1, 50 units of red light were required, 15 of orange and 18 of yellow.

---

<sup>1</sup>Quoted by Freund.

<sup>2</sup>Compt. Rend., Vol. XXIII., p. 679.

<sup>3</sup>Philosoph. Transactions, 1847.

<sup>4</sup>Philosophical Magazine, Vol. XXXII., p. 199.

The previous action of light on silver bromid may be neutralized by each part of the spectrum, from red up to violet. This was investigated by Waterhouse.<sup>1</sup>

Additional experiments with photographic preparations indicate that the opposed action of the red and violet energy is by no means proved. On the other hand, evidence points to a concerted action of the energy of the two ends of the spectrum.

That the red frequencies are of value in relation to therapeutics as well as in their physiological relation does not admit of question. The nature of the action of these frequencies is not yet well established, although considerable experimental work points to an action upon the sensory cortex. This has been considered at length under the physiological action of light.

The Energy of Red Light in the Treatment of Neurasthenia.—The important modifications which occur in the nervous system by the action of colored light rays or decomposed light, render it a valuable agent in combating neurasthenic conditions. Lille<sup>2</sup> believes that the red rays are to be preferred because of their greater penetrative power and their regulatory action upon the circulation.

In all hyperæsthetic conditions of the neurasthenic subject the effect of the long and slow frequencies of the red region are not only anodyne, but they have a beneficial effect on the general tone of the patient, with an increase in appetite and a general regulation of digestion and nutrition. Notwithstanding their great sensibility, neurasthenic patients bear treatment with red light without difficulty.

In the author's experience a complex of all the frequencies of light energy has been used in neurasthenic patients and with good results. If the results are better by the exclusion of all above the red it must be because the vibrations of the red frequencies are very long and slow. Theoretically it seems possible that the short and high frequency vibrations

---

<sup>1</sup>Proceedings of the Royal Society, London, XXIV., p. 186.

<sup>2</sup>La Semaine Medicale, April 25, 1902.



may act to still further irritate and exhaust the nerves which are already in a condition of exhaustion. The author believes that if a difference is made in the use of light energy in these cases, that the indications for the red frequencies of light is in those neurasthenics who have suffered a more or less complete exhaustion of the supreme nerve centre, the brain, and who in consequence are very much depressed, not only physically but mentally as well. In this connection the reader is referred to the chapter on physiological action and the case of the neurasthenic patient instanced there, with the intense craving for red fabrics and clothing. In that case there was profound anæmia of long standing and a severe exhaustion of the centres of the brain, motor and vaso-motor, sensory and intellectual.

The Possible Influence of (1) the Use and (2) the Exclusion of the Chemical Frequencies of Light Energy in the Treatment of the Psychoses.—The use of the energy of the red region of the spectrum as a therapeutic measure in melancholia has been referred to in discussing the physiological action of light and of energy of single frequencies or groups of frequencies as in the blue violet. There is certain clinical evidence pointing to more than a possible value which is supported by physiological action. An expenditure of the different frequencies or wave lengths as represented by the different colors of the spectrum must result in a different degree at least if not kind of work done in the living organism. This statement is true on physical grounds, and as has been stated is supported by some clinical evidence. To determine beyond question what place the use of exclusion of different degrees of light energy, as evidenced by the colors, has in the treatment of disease, especially nerve and mental, requires skilful, earnest, patient investigation on the part of scientific physicians. Psychopathic wards of hospitals offer an excellent opportunity for such a study, but it should not be undertaken as a fad but as a sober scientific investigation to which should be brought the physicist's training and the physician's skill. The author makes this suggestion with

no thought of supplanting any and every known therapy proven to be valuable in this class of cases, but simply with the hope that the method may either be completely refuted or else placed on a scientific basis and in its proper place in the therapy of nerve and mental diseases.

A somewhat extensive experience in the medical care of the insane, demonstrated the utter futility of all known methods of calming maniacal patients, unless heavily drugged, or of stimulating melancholiacs whose depression was so profound as to render life almost impossible to them, and a weight of woe to those who cared for them. Since the author's insight into the physics of light energy and its physiological action and experience in its therapeutic applications in a wide range of morbid conditions, including nerve pathologies, the hope has been inspired that concerted scientific effort might be made which would serve either to refute observed facts or if there is a grain of truth to determine wherein it lies. There is recalled a certain class of manias, in young hysterical subjects whose propensities for wilful, noisy and destructive conduct rendered them exceedingly difficult to care for and control, for whom theoretically at least seclusion in a blue room would have served as a quieting means. This without drugging or mechanical restraint, both of which were always avoided to the greatest extent possible by the author in the medical care of the insane.

In this connection the following statement made to the author by a Russian physician formerly a resident of Russia, but now of this country, cannot fail to be of interest and may serve still further to stimulate investigation, viz., that one of the methods used in the prisons occupied by prisoners whose socialistic tendencies had resulted in their arrest, exile and imprisonment, was to confine these prisoners, especially if alert and intelligent, in rooms from which all light energy below the blue is excluded for prolonged periods of time. The result is not only depressing so far as the spirit goes but is benumbing to the mental faculties, rendering the facile use

of the intellectual faculties an absolute impossibility. In this way these subjects are rendered harmless to the government, as well as unfitted to cope with the problems of life.

In the absence of the energy of light as a whole, bodily deformities, intellectual deterioration, crime and disease are found manifested in a higher state than in its presence. When the vital stimulus of light is withdrawn a material as well as a moral and a mental etiolation occurs.

## CHAPTER XVI.

The Concentrated Invisible Chemical Frequencies of the Spectrum or Ultra-Violet Rays. Mechanisms, Spark Condenser Lamps Excited by Alternating Currents, High Frequency Coils or Static Machines, Methods of Use and Therapeutic Indications.

### Ultra-Violet Light Energy.

By ultra-violet light is understood transverse vibrations of the luminiferous ether having a wave length smaller than .00004 cm.

These are very short light vibrations of very great frequency and invisible to the eye as light. The smallest wave length measured is .00001 cm. which is one-fourth of the length of the shortest wave length below the ultra-violet region.

The shortest wave length of which there is a photographic record is  $\lambda$  162  $\mu\mu$ . This was made by Victor Schumann, of Leipzig, who also secured a photographic record of hydrogen lines about  $\lambda$  100  $\mu\mu$ .

The ultra-violet rays are of intense chemical activity, and while sunlight at its source is rich in the very short and high frequency vibrations, constituting the ultra-violet region, but few if any of them reach the earth. They are absorbed by the atmosphere in transit from the sun, and the maximum chemical activity of the solar spectrum at the surface of the earth is found to be at wave length .00004, or just below the ultra-violet region. The ultra-violet sun spectrum is enormously bright at high altitudes, because there is not the same distance of atmosphere through which

the rays have to pass, and by which they are absorbed in attempting to pass.

The Ultra-Violet Spectrum of the Electric Arc.—The ultra-violet region from the electric arc is from six to eight times as long as in the visible spectrum. This was obtained by Stokes<sup>1</sup> through quartz. In comparison the ultra-violet region from sunlight is very short.

Means of Studying and Utilizing the Ultra-Violet Spectrum.—Stokes recommends quartz for the purpose of studying or utilizing the ultra-violet frequencies, but Schumann found that it absorbed the wave lengths below 200  $\mu\mu$ . He was, therefore, obliged to substitute for it fluorspar. With this he made his observation on the shortest wave lengths known, as referred to above, the spectrograph being made vacuous.<sup>2</sup> Grating spectroscopes are especially adapted for determining the presence of ultra-violet frequencies if the presence of glass be avoided. Photography supersedes all other methods of investigating the ultra-violet frequencies; but as those below 200  $\mu\mu$  are absorbed by gelatin, Schumann used plates without a gelatin film.

Maximum Energy and Maximum Chemical Energy of the Solar Spectrum.—The wave lengths constituting the visible spectrum are from .00004 cm. at violet to .00007 cm. at red. But while the maximum chemical activity of the solar spectrum is at wave length .00004, the maximum energy of the solar spectrum is at wave length .00008, or twice that of the maximum chemical activity.

By this maximum energy is understood the radiant energies of all the frequencies of sunlight from those of longest length and greatest amplitude to those of shortest length and the least amplitude in the swing of its oscillating corpuscles.

Influence of Temperature upon the Ultra-Violet Region.—The length of the solar spectrum beyond the violet is still unknown. In the ultra-violet region the solar spectrum does

---

<sup>1</sup>Ganot's Physics.

<sup>2</sup>Landauer: Spectrum Analysis.

not extend beyond about 300  $\mu\mu$ . As the temperature rises spectra tend to develop in the ultra-violet; hence on account of the extremely high temperature of the sun, a considerable portion of its spectrum must necessarily escape observation. The physical experimenter is, however, constantly endeavoring to find means for the development of these intensely chemical frequencies from artificial sources.

In view of all that is known of the action of ultra-violet frequencies, not only of the rhythmic flow of the oscillating light corpuscles of that region but of that single, solitary, infrequent impulse, similar, as it stands alone to the ultra-violet, the X ray, it requires little effort to believe that there is a region beyond the ultra-violet, as it is known and used to-day, capable of the most intense and violent physiological action.

Ultra-Violet Gradually Diminish Until they Become Roentgen Waves.—The lengths of the ultra-violet frequencies are known to be exceedingly short, and it is highly probable that they become still shorter until they become Roentgen waves. These latter are waves or solitary pulses in the ether. They have been likened to one single solitary shell, and owing to extreme thinness of the shell, they have extraordinary penetrative power. They have also been likened to a falling brickbat, coming once in a thousand years or so, as compared with the frequency and rhythm of ultra-violet rays. They travel in absolute straight lines, nor are they refracted or deflected by any substance, nor can they be bent aside. They may be stopped and be made to pass shadows, the sharpness of which depend only on the smallness of the radiant point; but unlike the waves of light, they cannot be bent. Lenses, prisms, magnets, electric charges, have no power over them. Hence they may be passed through all manner of substances, travelling through in a straight line path, and thus they throw the sharpest possible shadow if their source is a point.<sup>1</sup>

---

<sup>1</sup>Sir Oliver Lodge: Archives of the Roentgen Ray and Other Allied Phenomena, April, 1904.

Velocity and Intensity Reduced in the Ultra-Violet in Transmission through Glass.—So far as is known the velocity of light is the same for all frequencies. In travelling through the ether that fills the interatomic and intermolecular spaces of transparent substances, such as glass, the velocity is not only reduced, but the intensity of the vibration is also reduced, differently for different frequencies; high frequencies being generally more reduced than low frequencies. It is because of this physical law that the use of screens of colored, or lenses of clear glass, are to be avoided in the arrangement of any source of ultra-violet radiations for therapeutic work. The passage of the high frequency waves are thereby cut off to such an extent as to greatly reduce the beneficial results obtained. On the other hand, the high frequency waves readily pass through quartz without much absorption to wave lengths up to 200  $\mu\mu$ ; in other words, it is transparent to the pure ultra-violet rays. In this physical fact is to be found the reason why vacuum tubes of glass, however brilliantly they glow and hypnotize a credulous public, and even the profession, are absolutely devoid of true ultra-violet radiations.

The velocity of light is, to be exact, 186,400 miles a second or one foot in about the thousand millionth part of a second. But it does not travel at the same speed through water as through air, only three-fourths as fast or 138,000 miles per second. This would be but nine inches in a thousand millionth part of a second as against one foot. Through common glass it goes still slower. Some kinds of glass, that is, glass differing in composition, cause a greater retardation than other kinds, but on an average the retardation of light waves is such that they travel only about two-thirds as fast as in air. While a given source of light was travelling one foot through the air it would travel only eight inches through glass.<sup>1</sup>

Here again are the two physical reasons why light for

---

<sup>1</sup>Thomson, Silvanus P.: *Light Visible and Invisible*, p. 33.

therapeutic work where the intense chemical activities are required, should not pass through the medium of water or glass. The change in velocity is the result of the inability of the short high frequencies of oscillating light corpuscles or ultra-violet light to pass (1) through glass and (2) the absorption of these frequencies in passing through water.

Theoretical Completion of the Ultra-Violet Spectrum.—From the amount of dispersion of light, that is, its separation or analysis into its constituent frequencies or wave lengths by reason of the heterogeneity of the constitution of matter, an estimate of the size of the molecules can be made. It has been shown by Helmholtz, Stokes, Kelvin and other great mathematical physicists, that if wave lengths existed still smaller than the molecules they would tend to be treated all alike, just as they are when very much bigger than molecules.

Therefore, says Lodge,<sup>1</sup> a theoretical completion of the ultra-violet spectrum involves a complete folding of the spectrum back upon itself as it were, the higher frequencies being less and less bent, that is, refracted, and finishing off by rays that would not be bent at all, but, as von Helmholtz said, would proceed unrefracted and comparatively unabsorbed by ordinary opaque matter; that is to say, infinitely short waves would go on in straight lines and be very penetrating. This theory is beautifully illustrated by the X ray. They are not a continuous rhythmic chain of waves like light; they are ether pulses, but they are discontinuous, series of single pulses in enormous numbers not like an organ peal but like a constant succession of whip cracks from a million energetic drivers.

Somewhat the same sort of disturbances, though on a larger scale, is employed for ordinary wireless telegraphy.

The whole of this theoretical spectrum is not to be experienced from any known source. It is possible that the sun may emit it, but sunlight is unknown save as it is modi-

---

<sup>1</sup>Sir Oliver Lodge: Archives of the Roentgen Ray.



fied by the atmosphere, no matter what the altitude, although much less modified at high altitudes. This not only cuts down the ultra-violet energy, which is absorbed but the X ray energy, if it exists.

Ultra-Violet Light Energy Invisible, but Made Visible by Fluorescence.—While as has been stated the visible spectrum lies between wave lengths  $400 \mu\mu$  and  $760 \mu\mu$  if the longer waves are eliminated by suitable media, wave lengths far beyond  $400 \mu\mu$  are seen. But instead of the 400 millions of millions and 800 millions of millions presumed to be necessary to affect the retina the frequency of the ultra-violet goes up to 1,600 million millions per second. These are the highest frequency oscillations known and correspond to a thousand million million electric pulsations per second. Ultra-violet frequencies are, however, made visible by their action on fluorescent substances. This phenomenon depends upon the ability of certain substances to absorb energy of radiation at one wave length and to emit it at another. The phenomenon of fluorescence is not a property of the ultra-violet region alone. In this connection, however, it is of concern only in relation to ultra-violet frequencies. By the introduction of a fluorescent object, such as a plate of uranium glass, into the eye-piece of a prism spectroscope, ultra-violet frequencies of the source of light energy at once become visible.<sup>1</sup>

The same purpose was accomplished by H. von Helmholtz,<sup>2</sup> by placing a thin film of quinin sulphate in the telescope at the spot where the objective forms a true image of the spectrum. For the investigation of the ultra-violet frequencies, special instruments, with lenses and prisms of quartz are required, as they are absorbed by glass.

Langley<sup>3</sup> says of the ultra-violet spectrum in connection with a description of his infra-red or thermal spectrum that "it would take a hundred feet of map to depict it on the

---

<sup>1</sup>Soret quoted by Landauer, *Spectrum Analysis*.

<sup>2</sup>*Optique Physiologie*, p. 352. Quoted by Landauer.

<sup>3</sup>Langley, p. 684, *Smithsonian Report*, 1900.

prismatic scale, though this is caused by but a small fraction of the sun's energy, so monstrous is the exaggeration due to the dispersion of the prism. It really contains much less than the one-hundredth part of the total solar energy which exists, the visible spectrum containing perhaps one-fifth the energy of the sun."

In connection with this region interesting alike to the physicist and the medical man there is open here a new world to be explored, for all discoveries are "Pointing the way to future knowledge of the connection of terrestrial life with that physical creator of all life, the Sun."

Transmission of Ultra-Violet Rays.—While it has been pointed out that the air, glass, water and, for the shorter frequencies of this region, quartz even, are more or less opaque to ultra-violet rays, there are many other substances which have varying degrees of transparency or opacity for ultra-violet rays. The atmosphere is regarded as equivalent to thirty inches of mercury or four and one-half feet of lead in relation to ultra-violet energy. It is therefore very opaque to these frequencies.

There are four classes of such substances:

(a) Complete transparency throughout ultra-violet region.

(b) Opaque throughout ultra-violet region.

(c) Opacity increases with decrease of wave length.

(d) Exhibiting absorption bands.

(a) Complete transparency throughout the ultra-violet region: Potassium chlorid, sodium chlorid, strontium chlorid, thallium chlorid, indium chlorid, ammonia-aluminum sulphate, potassio-aluminum sulphate, rock salt, quartz, gypsum, solid alum, fluorspar and calcite (plate cut perpendicularly to optic axis).

(b) Opaque throughout ultra-violet region: window glass from wave length .0000325 m., plate glass and flint glass wave length .0000325 m., black glass, red glass, uranium glass, blue tourmaline, green tourmaline, chlorophyll in alcohol, alcoholic solution of stramonium salt.

(c) Opacity increases with decrease of wave length: white mica.

(d) Exhibiting absorption bands: iodine in  $CS_2$ , uranium nitrate.

At a meeting of the American Physical Society in December, 1902, Professor R. W. Wood of the Johns Hopkins University, described and exhibited a screen which was transparent to ultra-violet rays. This was made by combining a gelatin film containing nitroso-dimethyl-anilin with copper oxid and cobalt glass. While being opaque to the rest of the spectrum such a screen is very useful in photographing the ultra-violet spectra since it enables the overlapping spectra of other orders to be eliminated. The author showed an interesting lecture experiment in which the rays of the lantern, after passing through such a screen, were concentrated to an invisible focus, where a suitable fluorescent substance was excited. This should furnish an invaluable means of sifting out other frequencies and studying the action of ultra-violet frequencies alone in therapeutic work as well as physical experiment.

Absorption in the Ultra-Violet.—Sunlight contains much ultra-violet at the top of mountains and some wherever the air is clear as at sea: clean water vapor not being very opaque to it. But the thinnest veil of smoke or other foreign material in the air cuts off the whole of the ultra-violet region, letting the heat rays through undisturbed, however, in fact, even helping to entrap them. For these reasons sunlight in or near towns has very little chemical activity. There is enough to affect sensitive photographic plates, but not enough for bleaching or other chemical purposes, nor is there sufficient for bronzing the skin or the destruction of bacteria. In the country, on the other hand, the ultra-violet residue which reaches the earth's surface, is entirely within physiological bounds and produces effects which, as a rule, are attributed to ozone.

According to Cornu<sup>1</sup> the absorption of the ultra-violet

---

<sup>1</sup>Landauer: Spectrum Analysis, p. 202.

region is not caused by the varying constituents of the atmosphere, such as water, vapor, or dust, but essentially by nitrogen and oxygen. He has suggested a formula for the calculation of the solar spectrum absorbed by the column of air which the light traverses; according to this a thickness of 663 metres causes a diminution of  $10 \text{ \AA}$  at the ultra-violet end.

The investigations of Hartly and Huntington<sup>1</sup> showed that the normal fatty acids have a stronger absorptive power for the refractive rays of the ultra-violet region than the corresponding alcohols, and that increase in absorptive power in this part of the spectrum is correlated with increase in the number of  $\text{CH}_2$  group in the molecule of the homologous alcohols and acids.

In the case of the alcohol and the acids the absorption increases as the content of carbon in the compound increases. A simple linkage of carbon and nitrogen is sufficient to produce characteristic absorption of the ultra-violet rays.

Hartly also examined the spectrum of carbo-hydrates and albuminoids, investigating the physical combination of these compounds with the soluble ferments. The spectra of egg albumen and casein exhibit certain bands in common which are absent in the spectra of malt-diastrase, yeast invertase, gelatin, starch, glucose and saccharose, solutions of which are particularly transparent to the violet and ultra-violet rays. The albumens are thus shown to differ considerably from the ferments in constitution, and this accords with the difference in behavior shown by the compounds toward the carbo-hydrates. Other substances for example, benzene and its hydroxyl, carboxyl, and amido derivatives, have a light absorption power for the ultra-violet rays, and in thin layers exhibit strong absorption bands.

Absorption in the Ultra-Violet by Quartz Media.—Ultra-violet  $\lambda$  350  $\mu\mu$  are absorbed to a very considerable extent, and those of about  $\lambda$  300  $\mu\mu$  completely through the media

---

<sup>1</sup>Ibid.

of glass. The author wishes to make this statement so emphatic that no question can arise in the mind of the student as to the phenomena presented by vacuum tubes of glass. Nor does the arrangement of the mechanism used to produce these phenomena as a possible source of ultra-violet frequencies need to concern him so long as tubes of glass are used. Ultra-violet frequencies may be generated thereby, but so long as they are within the glass they are of no avail for therapeutic purposes.

In defiance of the well-known physical law the statement is constantly made by those interested in the manufacture of vacuum tubes for medical work, that vacuum tubes of glass, unipolar or bipolar, are an efficient source of ultra-violet radiations.

Willemite as a Test for Ultra-Violet, Cathode and X Rays, also for High Frequency Currents.—In this connection it may be stated that willemite is commonly used by physicians in testing the light values of different forms of light apparatus. It fluoresces under the influence of X rays, cathode rays and ultra-violet rays. It is believed by physicists that it will fluoresce under other conditions, high frequency vibrations, for example.<sup>1</sup> It is only considered a conclusive test for the existence of ultra-violet rays when used to locate the spectrum of a source of light which has been produced by means of grating, or by quartz lenses and prisms.

Glass Transparent to Wave Lengths Longer than 30 Microcentimetres.—The fact should not be lost sight of that glass is transparent to longer wave lengths, and that these frequencies possess to a greater or less extent the properties of the higher frequencies. This is shown in photography, and is also a matter of daily observation in the therapeutic uses of light. Glass is transparent to the blue-violet or longer wave lengths, and they are valuable in therapeutics, but so far as proven, not as valuable as the ultra-violet either in bactericidal power or in ability to excite tissue reaction.

---

<sup>1</sup>See Fluorescent Action of High Frequency Currents under Vacuum Tube Discharges, Chap. XVII.

They are, however, capable of greater penetration within the tissues.

In Therapeutics a Complex of Wave Lengths, Blue Indigo, Violet and Ultra-Violet Most Valuable.—But while these invisible ultra-violet frequencies are of great intrinsic value it must never be lost sight of for one moment that the complex of wave lengths blue, indigo, violet and ultra-violet is infinitely more valuable.

Ultra-violet rays have the following properties:

- (a) Chemical changes on silver salts, etc.
- (b) The production of fluorescence.
- (c) Electrify positively metals, especially polished zinc.
- (d) Decrease necessary break down voltage of an air-gap on which they shine.

(e) Discharge negatively charged bodies on which they shine. Of these phenomena, (c), (d), and (e) are considered to be due to ionization of the air; (b) may be due to mechanical impact disturbances or to resulting rise of temperature; while (a) may be due to any of these causes.

Chemical Changes Induced by Ultra-Violet Energy.—Under the chemical changes induced by ultra-violet frequencies there is not only the well-known action on silver salts, but their physiological effects upon animal and vegetable life, which are fully considered under their appropriate headings. Bronzing of the skin is due to the ultra-violet light which the air does not stop, and which is reflected from snow or ice as well as received directly from the sun and sky and clouds.

Affinity of Ultra-Violet Frequencies for Oxygen.—These frequencies have a great affinity for oxygen, and it has been pointed out by Sir Oliver Lodge<sup>1</sup> recently, that if the same conditions could be produced in the interior of the body, pelvic tissues, for example, that exist on the exterior, i.e., the presence of free oxygen, that ultra-violet rays, X ray and radium would necessarily be more effectual in their ac-

---

<sup>1</sup>Lodge, loc. cit.

tion. Were it not for the free oxygen on the superficies of the body, the intense oxidizing action as evidenced by the blistering of the skin and bactericidal effect, would not take place. Were it possible to introduce it deep within the tissues the same action would take place there.

Special Action of Ultra-Violet Frequencies upon Skin of Man, Tissues of Lower Animals and Plants.—Ultra-violet frequencies not only have a special action upon the skin of higher animals, but upon the entire tissues of the lower animals and plants. High up where the air is rarefied the action upon the skin is so strong as to produce intense erythema, unless time is given for the development of pigment cells.

Influence of Screens of Glass.—A screen of glass will effectually prevent this action as it will absorb the ultra-violet frequencies. Under the action of electric light upon plants it is pointed out that a naked arc lamp will wither the leaves of plants by reason of its intense chemical energy in the ultra-violet region. By the interposition of glass they are shut off and the transmitted frequencies are the usefully active chlorophyll-stimulating rays. It takes the place in relation to the arc that the atmosphere does in relation to the original energy emitted by the sun. This action can be very quickly shown by permitting the energy of the unprotected arc to fall upon one-half of a leaf, and through a glass screen on the other half, the unprotected leaf will turn brown and the other remain green.

The Electroscope the Best Test for Ultra-Violet Rays.—The best test for determining the presence of certain kinds of radiation is the electroscope. An electroscope is an apparatus (1) for detecting the presence of electrification, and (2) for detecting differences of potential. With it the presence or absence of ultra-violet frequencies can be determined. When it is placed in ordinary light the electrically charged leaf of the electroscope, no matter of what metal made, will not leak; but when connected to a piece of clean zinc, it will leak rapidly when ultra-violet rays fall upon it.

Fig. 33 shows an electroscope with the leaves diverging and ending externally in a polished zinc ball. When exposed to the ultra-violet rays, the electroscope at once begins to be discharged. It is the same part of the ultra-violet frequencies, which are active for therapeutic purposes, which discharge the electroscope. If a piece of glass intervene between the electroscope and source of ultra-violet energy no action whatever takes place, there is no leakage of the charged body, but remove the glass and it is quickly discharged, or interpose a piece of quartz and it is discharged



Fig. 33.—Electroscope with polished zinc ball, for showing the effect of ultra-violet rays.<sup>1</sup>

just as quickly. The ultra-violet frequencies from the condenser spark will discharge an electroscope in five seconds as against twelve seconds from an arc light. This shows the preponderance of these frequencies in spark charges. The breaking down of the electrical resistance of the air is due to the frequencies of very short wave length. Ultra-violet rays also produce nuclei for cloud condensation in moist air. Professor Lenard has come to the conclusion that wave lengths  $\lambda$  1,600 to  $\lambda$  1,900 are active in this regard.

The Nature of the Action of Ultra-Violet Energy in Discharging an Electroscope.—In the leakage of a regularly charged electroscope, with a recently cleaned zinc terminal, from the action of ultra-violet energy, atoms which have ac-

<sup>1</sup>Sir Oliver Lodge: The Archives of the Roentgen Ray.



quired an extra or supernumerary electron will, when jostled by ultra-violet waves, that is, the vibrational activity of oscillating corpuscles not very different from the periods of vibration natural to the atoms themselves, fling the extra electron off.<sup>1</sup> This action can be immediately stopped by the intervention of a screen of glass, as visible light has no such effect. If the charge is positive instead of negative the action is also nearly suspended. If the zinc surface is dirty it is much slower still. There is a slight residual action on most surfaces, as those of rocks and leaves, for example, whether they be charged positively or negatively. This is a part of the cause of atmospheric electricity, but it is a small effect compared with the rapid leakage from negatively charged, recently cut or scratched surfaces of metal.

Difference Between Action of Ultra-Violet and X Ray Energy in Discharging Electroscopes.—In instituting a comparison between ultra-violet and X ray energy, the latter will be found to cause violent leaking of the electroscope, no matter whether it is positively or negatively charged, and no matter what its surface may be. The X rays do not act upon the surface but upon the air. On the air they act chemically, ionizing, breaking up its molecules into charged atoms, rendering it, therefore, a conductor or electrolyte, in which all charged bodies must rapidly lose their charge. These effects persist for a time after the X rays have ceased, until the dissociated atoms have had time to recombine in the molecules and the air resume its normal condition. This property of "ionization" must be the most important therapeutic property of the X ray. Light has only the ability to act on unstable chemical compounds while X rays seem able to shake asunder even stable molecules, the molecules of ordinary substances. For example, they can produce a violet color in manganese glass and can color various salts. They strongly shake asunder the binary molecules of atmospheric oxygen and nitrogen, dissociating them into

---

<sup>1</sup>Lodge, loc. cit.

free ions, which may subsequently combine into oxides of nitrogen and ozone as well as their original simpler molecules. Radium rays which have penetrated glass and mica can oxidize iodoform, turning a solution of it in chloroform deep brown by these penetrable rays.<sup>1</sup>

Lodge,<sup>2</sup> whose views on the differences and similarities between the action of X rays and ultra-violet light energy have been quoted, further states, that as regard the cells of the body, the former probably act most on active cells, where changes are occurring, and that he should expect them to act, therefore, more on the dermis than on the epidermis. He concludes that it would be odd if they did not act upon the hæmoglobin. That they have such an action, the author believes, and that this action, a deleterious one ultimately, is the cause of the ghastly chlorotic coloring of those exposed for long periods to the action of X ray energy.

Just upon going to press, the author finds that this opinion hazarded by Lodge from purely physical considerations, and which was endorsed by the author from physical considerations, supplemented by clinical observation, has been established by experimental observation.

Darier, Unna, Jutassy and Minich among others, by microscopic examinations of the exposed cutis, showed the correctness of Lodge's hypothesis as to the action of this energy upon the dermis. The experimental researches of H. Heinecke, as well as the clinical observations of M. Mauté, have established the correctness of the hypothesis as to the action of the X ray on the hæmoglobin.

Mauté has carefully studied the cellular composition of the blood in cases treated by radiotherapy (exposure 2 to 6 minutes), and has noticed that during the hour following the exposure, there is an appreciable modification of the cellular equilibrium of the blood, which is attended by an increase in the number of both the white and colored corpuscles, the percentage of polynuclear and large and small

<sup>1</sup>Hardy and Wilcox, "Proc. Royal Soc.," Vol. LXXII., p. 202.

<sup>2</sup>Lodge, loc. cit.

mononuclear cells being greater than normal. The leucocytosis thus induced is analogous to that set up by revulsive applications (vesicants, cold, etc.), or that which attends digestion. Heinecke's experiments, on the other hand, go to prove that the lymphoid structures of the body are even more susceptible to the X rays than the cutis. In small animals exposed to the rays for some hours the spleen showed an excessive increase in pigment, a disappearance of the follicles and a general destruction of the splenic pulp. The follicular changes were noticed soon after the exposure to the rays, and were completed in 24 hours. The nuclei of the lymphocytes in the follicles are first disintegrated, their remnants being removed by phagocytes, which in turn disappear from the spleen when the destruction of the follicles is complete. It was found that an exposure of 15 minutes is sufficient to start these changes in rabbits and small dogs. In the case of short exposures the amount of destruction is limited and repair can undoubtedly take place.<sup>1</sup>

#### Ultra-Violet Frequencies.

- (1) Can be reflected, refracted and polarized.
- (2) Will not traverse bodies that are perfectly pervious to luminous frequencies, for example, glass.
- (3) Will not influence the deeper tissues, nor even the superficial ones, unless they are deprived of their blood, i.e., dehæmatized. (It has been shown that they penetrate a frog's web even when the blood is circulating and the conclusion is reached that they pierce the epidermis and are able to reach the lower layers of the skin.)
- (4) Will be stopped by a single leaf of paper.
- (5) Will rapidly destroy the vitality of bacteria.
- (6) Will produce inflammatory action on the skin.
- (7) Will discharge an electroscope if electrified negatively, but not positively.
- (8) Will excite green fluorescence in willemite, and induce blue phosphorescence in polysulphide of calcium.

---

<sup>1</sup>Editorial, Medical Electrology and Radiology, July, 1904.

(9) Rock salt is transparent to ultra-violet frequencies.

Photo Electric Effects of Ultra-Violet Light Energy.— In 1887, it was discovered by Hertz<sup>1</sup> that the incidence of the ultra-violet light on a spark gap facilitated the passage of the spark. Since then experimental work at the hands of physicists has established the fact that a newly cleaned surface of zinc, if charged with negative electricity, will rapidly lose its charge upon exposure of its surface to ultra-violet light. On the other hand, if uncharged to begin with, it will on exposure to ultra-violet light rapidly acquire a positive



Fig. 34.—Experiment showing ultra-violet rays discharging a piece of zinc. *U*, ultra-violet lamp; *Z*, zinc; *B*, wire connecting zinc with electrode *E*.<sup>2</sup>

charge, the negative electrification going out meanwhile into the gas by which the metal is surrounded.

By directing a powerful air-blast against the surface of the positively charged surface the charge will be greatly increased. This zinc surface when positively charged suffers no loss upon exposure to the air. Any light source rich in ultra-violet frequencies may be said to produce these effects, the electric arc, burning magnesium or the spark from an induction coil or static machine between zinc or cadmium terminals, the light from which is very rich in ultra-violet frequencies. Although the solar light is not rich in ultra-violet frequencies, it has been shown by the experiments of Elster and Geitel<sup>3</sup> that the more electro-positive metals lose negative charges even when exposed to daylight. In their power of discharging negative electricity, metals may be arranged in the following order according to the same investigators:

<sup>1</sup>Hertz: Electric Waves.

<sup>2</sup>Sir Oliver Lodge: Archives of the Roentgen Ray.

<sup>3</sup>J. J. Thomson: Conduction of Electricity Through Gases, p. 212.

Rubidium, potassium, alloy of potassium and sodium, sodium, lithium, magnesium, thallium, zinc. The effects of ordinary light upon copper, platinum, lead, iron, cadmium, carbon and mercury are too small to be measured. The order of the metals for this effect is the same as that of Volta's for contact electricity, the most electro-positive metals giving the largest photo-electric effects.

The action of ultra-violet light induces the discharge of negative electricity in many substances other than metals. Thomson mentions among the more active photo-electric solids, the following: Fluorspar, the various colored varieties of which vary greatly in the degree to which they possess this faculty; the sulphids of antimony, lead, arsenic, manganese, silver and tin (the sulphates do not possess this property); hydroxid of tin, iodid of lead, and many anilin dyes in the solid state. A thin surface of water over a metal will interfere with this function as water is not photo-electric. The solutions of many substances are, however, actively photo-electric. Especially is this true of the fluorescent substances, for example, eosin, fuchsin, cyanin, hydrochinon, congo red; potassium nitrate and formic acid also show this effect. On the other hand solutions of sulphate of quinin, potassium permanganate and phenol do not show this effect.

A different effect is observed in gases from the case of solids and liquids as a result of the action of light, as it is not possible in gas to get a separation of the gas that one part may become positively electrified and another negatively electrified. If a molecule of gas, when exposed to ultra-violet light, loses, as does a piece of metal, its negative electricity, then it will behave like a positive ion and the negative corpuscle it has lost will attach itself to some other molecule of the gas which will act like the negative ion.

Therefore Thomson concludes that if the same effect is produced upon the molecules and atoms of a gas, as upon a mass of metal, by the action of ultra-violet light, an ionization of the gas would follow. From every point of view this seems to be the case, and the electric arc because of its

ultra-violet frequencies acts to produce an ionization of the air. This ionization of the air of an electric arc bath for example, the author believes to be one of the therapeutic factors.

A connection also exists between the photo-electric effects and the absorption of ultra-violet light. Stoletow, quoted by Thomson, pointed out that water which does not give photo-electric effects, does not absorb many of the visible or ultra-violet rays, while photo-electric solutions, such as those of methyl green or violet which are photo-electric show strong absorption.

A more extensive investigation of the subject by Hallerachs<sup>1</sup> showed that all the photo-electric liquids which he tried showed strong absorption for ultra-violet light. On the other hand strong absorption was not always accompanied by photo-electric effects; thus, for example, the aqueous solution of fuchsin is photo-electric while the alcoholic solution is not, and yet more ultra-violet light is absorbed by the alcoholic than by the aqueous solution.

The photo-electric effects do not exist when the source of light is removed, Stoletow<sup>2</sup> having showed that the interval between its removal and the total cessation of effects was not more than  $1/1000$  of a second. G. C. Schmidt investigated the relation between photo-electric effects and the fluorescence and ionization of solutions but was unable to obtain a clear evidence of any intimate relation between photo-electric effects, ionization and fluorescence. Different salts and solutions examined presented widely varying results. Some seemed to show a clear relation between photo-electric effects and ionization, others not.

Metals in High Vacua when Illuminated with Ultra-Violet Light Give out Corpuscles.—Thomson's<sup>3</sup> and Lenard's experiments show that in high vacuum, metals when illuminated with ultra-violet light give out corpuscles, i.e., bodies

---

<sup>1</sup>J. J. Thomson: *Conduction of Electricity Through Gases*, p. 217.

<sup>2</sup>Thomson.

<sup>3</sup>Thomson, p. 241.

whose mass is only about 1/1000 of that of the hydrogen atom; when, however, the metal is surrounded by gas the corpuscles soon strike against the molecules, get attached to them and have to drag them along with them as they move under the action of the electric field.

Rutherford<sup>1</sup> found upon measurement that the velocity of the negative ions through different gases did not depend upon the nature of the metal on which the light fell, but that it did depend upon the nature of the gas through which the ion had to travel; and that the velocity through any gas of the negative ion produced by ultra-violet light, was approximately the same as that of the ion produced by Roentgen rays through the same gas.

Methods of Production of Ultra-Violet Rays.—Were it possible to utilize the sun's radiant energy before its passage through the air, a source of very great ultra-violet activity would be at command. Luckily for both animal and vegetable life this is impossible. The intense chemical action generated thereby would be disastrous. But fortunately there are artificial sources of light at command rich in ultra-violet frequencies and capable of perfect control, which can be used in therapeutic work. The value of the electric arc, with electrodes of carbon, of iron and carbon and of iron alone, requiring from 5 to 80 ampères of current, has been duly considered. From all those sources, however, the luminous output is a complex of all the frequencies of the spectrum. This is true in the following order: (1) the carbon arc; (2) the iron and carbon arc (more violet and ultra-violet); (3) the iron arc (more ultra-violet).

Ultra-Violet Energy Assumed to have been the Principal Factor in Therapeutics.—It was assumed both from experimental work and from Finsen's work with powerful electric arcs, so active chemically and especially so rich in ultra-violet frequencies, that the results obtained were largely due to the latter. Therefore there has been a constant endeavor on the part of both physicians and operators,

---

<sup>1</sup>Quoted by Thomson.

during the past few years, to devise mechanisms for use with sources of light especially rich in these rates of vibration.

To this end the iron electrode lamps which have been considered in the previous chapter were constructed. As has been seen they give a spectrum in which the violet and ultra-violet predominate.

Here it is only the purpose to speak of methods for the production of the ultra-violet frequencies, or at least as nearly pure as it is possible to have them.

At a Temperature Higher than Boiling Carbon More Ultra-Violet Energy.—A high temperature source is necessary for the production of ultra-violet energy. For it, the chief sources are the electric arc, an electric spark or a brush discharge. An artificial source of light hotter than boiling carbon will give a light richer in high frequency waves, not only of higher intrinsic energy, but of greater total energy, capable of most profound chemical action.

The Electric Spark Rich in Ultra-Violet.—In the electric spark, whether from a static machine or a high tension coil, is to be had a source very rich in these frequencies, especially when metallic terminals, such as zinc, copper, iron, cadmium, aluminum and mercury are employed. For this purpose iron is perhaps the best. It vibrates at 480 different velocities and gives a spectrum extending from  $\lambda$  6678.23 Å to  $\lambda$  2214.70 Å (corrected according to Rowland's tables).<sup>1</sup>

Especially is this true of powerful high tension coils, such as those of Tesla and Elihu Thomson. The negative terminal is particularly active in this way. The lightning discharge is also powerfully active chemically, the frequencies of the ultra-violet predominating. The light of spark discharges has been used many years by experts in photography and spectrography, in their spectroscopic and photospectrographic experiments, the intensity of which has been increased by the use of Leyden jars. The light from these sources has a powerful bactericidal effect. The first sugges-

---

<sup>1</sup>Landauer: Spectrum Analysis.



tion for the use of spark discharges from an induction coil as a source of light energy in therapeutic work was made by Görl.<sup>1</sup> At the same time Leduc,<sup>2</sup> in experimental work, showed the exceeding richness of the spark discharges of an influence machine in ultra-violet frequencies.

He found that photographic effects were obtained surpassing in intensity those of sunlight, from the spark of an influence machine, and that the light produced an intense fluorescence on a platino-cyanid screen, without concentrating the beam, and he suggested in 1901 that it be used as a source of ultra-violet light for therapeutic work.

The use was considered by the author as early as 1899, but owing to a multitude of duties, no effort was made to put the thought into execution, and as an 80-ampère arc was in use in connection with a Finsen tube there was no need of the mechanism.

Bactericidal Effect of Spark Light.—Marshall Ward<sup>3</sup> and Strebel<sup>4</sup> have furnished proof of the powerful bactericidal effect of spark light. By his experiments Strebel showed that the spark of an induction coil at a sparking distance of 20 cm. kills all kinds of microbes at 70 to 140 cm. distance in a few minutes. If the objects were brought to the source of the light, the same result is obtained, but in a space of time which compares favorably with the arc light.

The Görl Apparatus for Spark Light from a Static Machine or Coil.—The Görl apparatus for the production of spark light consists of five aluminum balls arranged in the form of the letter S, along which, from ball to ball, the spark flashes. These are insulated, set in a hard rubber or mica, preferably the latter, base, and covered with a cap in which is placed a quartz disc.

---

<sup>1</sup>Görl. "Zurlicht Behandlung mit ultravioletten Strahlen." Muenchner Medicinische Wochenschrift, No. 19, Mai 8, 1901.

<sup>2</sup>Production Électrique des rayons chimiques pour les applications Médicale. Annales d'électro-biologie, March-April, 1901.

<sup>3</sup>Proc. of the Royal Society of London, 1904, Vol. IV., p. 472 ff.

<sup>4</sup>Deutsche Med. Wochenschrift, 1901, Nos. 5 and 6. Quoted by Freund.

The Strebel Spark Lamp.—The Strebel instrument for producing ultra-violet light, from an induction coil, consists of a short ebony tube, 6 cm. broad, which is closed on one side by a quartz lens, on the other by a concave mirror of magnalium metal.

The conducting wires pass through the walls of this apparatus and terminate in one or more pairs of aluminum electrodes which stand opposite to each other, a short distance apart, in front of the concave mirror. Air is forced into the capsule by means of a small bellows, which serves to keep the electrodes from becoming heated, and also to drive out the ozone and metallic vapor formed by the spark.

St. Bartholemew's Induction Coil Arc Lamp.—The Görl instrument is manufactured in London under the name of the "St. Bartholemew's Induction Coil Arc Lamp." It is also manufactured in this country, as shown in Fig. 35, and was

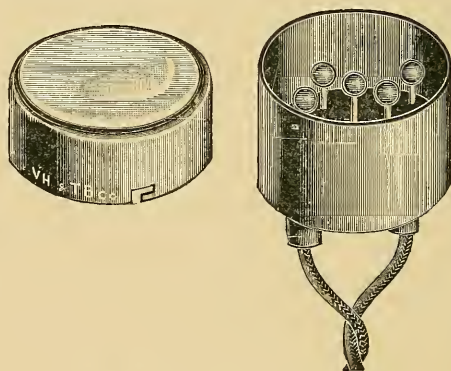

Fig. 35.—The Görl Lamp.

described by the author in an article bearing date February 7, 1903.<sup>1</sup> The five aluminum (iron has been used in the same apparatus as well) rods, capped with balls arranged in the form of a figure S, are set in a hard rubber base continuous with a cylinder of hard rubber (a). This is in turn filled with a plate or disc of quartz (b), for the purpose of con-

<sup>1</sup>Cleaves: Portable and Easily Adjustable Mechanisms for Ultra-violet Light, N. Y. Medical Record, March 27, 1903.

centrating the light, and which also serves as a compressor to render the part to be treated anæmic.

It may be used with or without the Leyden jars in circuit. The author uses it as a rule without, connecting it directly to the discharging rods of the static machine or the terminals of a high tension coil, an X ray coil, for example.

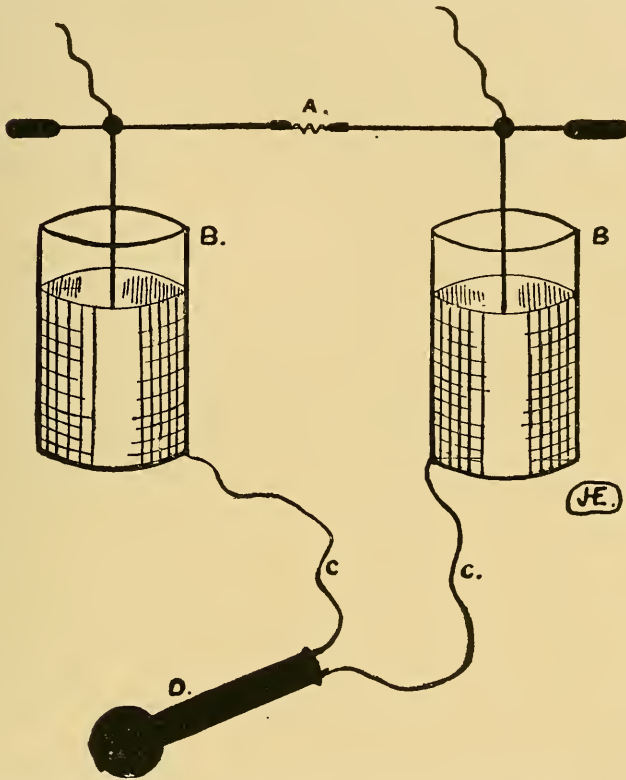

Fig. 36.—Showing ultra-violet lamp connected with the outside coatings of two Leyden jars.<sup>1</sup>

A similar lamp is shown in circuit with the Leyden jars in the accompanying cut.

The Piffard Induction Coil Arc Lamp.—Piffard<sup>2</sup> re-

<sup>1</sup>Sir Oliver Lodge, Archives of Roentgen Ray.

<sup>2</sup>Piffard: Radio-Praxis, N. Y. Med. Record, March 7, 1903.

ported a modification of the St. Bartholemew Induction Coil Arc Lamp in a paper read before the New York Academy of Medicine, February 19, 1903. The London lamp has but one spark gap as against four in the original Görl apparatus. The Piffard lamp has three spark gaps. The balls are also set in a hard rubber base, surrounded by a cylinder, and in turn fitted with a cap containing a disc of quartz. The hard rubber cylinder has about its circumference several openings for the purpose of cooling the electrodes, and freeing the air from ozone and metallic vapors. By reason of these openings it is more difficult to secure the passage of the spark in humid atmospheric conditions. The principle is the same in all.

The author's work has been done with the one shown in the cut.

A Vaginal Spark Lamp.—The author utilized the same principle in having constructed a vaginal lamp, but as it was constructed of glass, its usefulness was at once minimized, as there are present in the spark discharge very few of the frequencies of greater wave length than the ultra-violet, and the latter could not pass owing to the glass enclosing cylinder. It was noted, however, when using it in cases of cervical cancer, that upon withdrawal a chemical action was evidenced by the discoloration (oxidation) of the vaginal discharge. As this took place, however, on that part of the external surface of the glass enclosing cylinder, opposite to which the metal balls approximated very closely in the interior, it was thought to be due to the electrical discharge.

Strebel<sup>1</sup> has also utilized the same idea for the treatment of the accessible mucous cavities, but the cylindrical glass tubes and catheters are open to the same objection as in the author's vaginal lamp. It is possible to have a quartz disc to serve as a window sealed into the distal end of the apparatus, then the diseased cervix and adjacent tissues would be exposed to the action of the ultra-violet frequencies. By

<sup>1</sup>Freund: Radiotherapy.

having a separate and longer cap, i.e., hard rubber tube, of a little less diameter and 4 to 6 inches long, with the quartz disc fitted in as now, the lamp shown in cut can be adapted to gynæcological work. The cap could be easily removed and cleaned while the insulating base and metal electrodes could be kept perfectly dry. The quartz disc is more readily fitted into the hard rubber tube cylinder than cemented into a glass tube.

There is no question but that the ultra-violet frequencies thus obtained would serve an excellent purpose, in a good many cervical and uterine conditions, an eroded cervix, for example.

But there are many other means to the same end, and in the use of light energy, the methods pointed out in Chapter XII. and XIII. under the use of the concentrated energy of electric arc spectra, and the concentrated energy of incandescent light spectra, amply suffice.

Strebel<sup>1</sup> also proposed as another form of spark light, the rays given out by the opening spark of a Wagner hammer, with an induction apparatus. He showed that this light, when the interrupting spark is produced by aluminum contacts, is very rich in color rays, though not to so marked an extent as the voltaic arc, but richer even in ultra-violet rays.

The Utilization of the Ultra-Violet Energy from an Influence Machine.—Leduc, who was the first to utilize the ultra-violet rays of the discharge from an influence machine, used as a condenser, a capsule with a quartz end, the latter serving also as a compressor. One may use from five to ten of these condensing lamps connected with the one spark gap of an influence machine. The output of such a machine is so tremendous as compared with the voltage required for a single lamp, that the many can be operated equally well with the one. In this way several patients can be treated at the same time. Leduc also devised an apparatus to use with a powerful induction coil. Both Freund and Strebel

---

<sup>1</sup>Freund: Radiotherapy.

have pointed to the possible therapeutic utilization of the ultra-violet frequencies in the electric brush light. Strebel constructed a small condenser which projects these discharges in a circular plane.

The following arrangement of apparatus, as a source of intense ultra-violet activity, was suggested by Mr. W. S. Andrews. The author is indebted to Professor Samuel

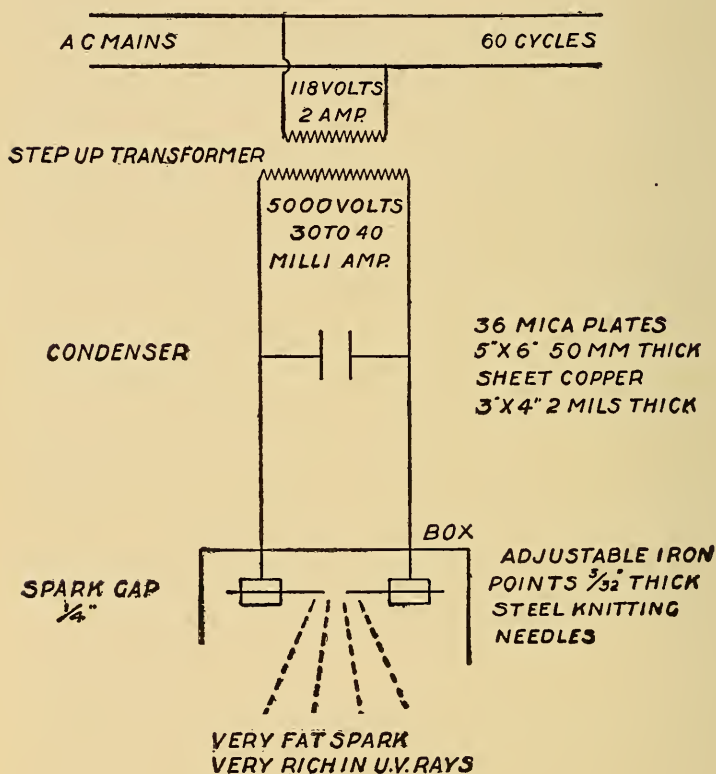

FIG. 37.

Sheldon,<sup>1</sup> of the Brooklyn Polytechnic Institute, for communicating the suggestion, and for the drawing shown in the accompanying cut.

<sup>1</sup>Personal communication.

There are also to be had other makes of apparatus to use with static machines or coils for the production of ultra-violet rays, but the underlying principle is the same in all.

The Strong Ultra-Violet Spark Lamp.—There is a very excellent one to use with the Strong high frequency apparatus. The principle of this coil is that of Tesla's. These coils are well adapted to the production of ultra-violet frequencies.

An Alternating-Current Arc for Spark Light.—There is another which is largely used, shown in Fig. 38. This is connected directly with the alternating-current mains. It is a very efficient lamp, and the one used in the case of pemphigus reported in this connection was of this make.

The current is to be turned on gradually to prevent undue heating of the lamp mechanisms. Care should be taken in using these lamps with powerful coils not to permit too much current to pass. In this way undue heat will be generated, melting the hard rubber of which the base is made.

The Action of Spark Light upon the Skin.—The effect upon the skin from the light energy from these condenser lamps whether excited by an induction coil or by a static machine is exactly the same as that produced by the effective energy of the voltaic arc; that is they produce erythema and pigmentation. The biological action of the light energy from these sources is to a very great extent that of ultra-violet light energy, for, as has been stated, there are very few of the longer and slower frequencies produced in this way.

It is probable also that there are effects due to the electric waves originating in the spark. Still with the Görl lamps there is apparently no evidence of any electrical action. With the cylindrical glass tubes for vaginal or rectal use, there is unquestionably an effect from the electrical discharge as well. Owing to the length of the rods supporting the metal balls between which the spark flashes they are apt not to keep the centre of the tube and the discharge then leaps off to the sides of the glass tube.

Therapeutic Use of Spark Light.—No one seems to have published so extensive reports from the use of these Spark Condenser or ultra-violet lamps as Strebel. According to him, treatment proceeds rapidly with these lamps, as a surface of at least five centimetres in diameter can be exposed to the action of the ultra-violet rays at once. The light is absolutely cold, which renders its use very simple and easy. Exposures may be made every one to three days, and from fifteen minutes to an hour in duration. Strebel claims good results. In lupus vulgaris, distinct improvement followed several exposures of forty-five minutes each; venereal ulcers healed after several exposures of half an hour each; obstinate psoriasis, from eight exposures of one and one-half hours each; a plaque of herpes tonsurans as large as a five mark piece (about the size of a silver dollar) twenty-one exposures of half an hour each; sycosis, twelve exposures of twenty-five to thirty minutes each, simultaneous epilation; eczema madidans two exposures; ulcus cruris, healing after nine to twenty exposures; and alopecia areata eight exposures. Also according to Strebel as reported by Freund, this treatment has been very successful with diseases of the mucous membrane, arresting the discharge and causing the disease to disappear, fluor albus blenorragia, with twenty minutes exposure every fourth day combined with salt water douches; chronic metritis from ten intra-uterine exposures to the light energy; gonorrhœa in the male, ten exposures of fifteen minutes duration; venereal warts three exposures.

Strebel admits that the treatment may possibly produce violent irritation of the mucous membrane, inflammatory swelling and pain on micturition.

The author with an equipment consisting of various sources of light energy from a Görl lamp to an 80-ampère arc, has used the former rarely because of the greater value of the others. Still it has been used in connection with a powerful influence machine (Holtz) sufficiently to determine its individual and comparative value. A patient with pelvic cancer, who was under care for X ray treatment reported



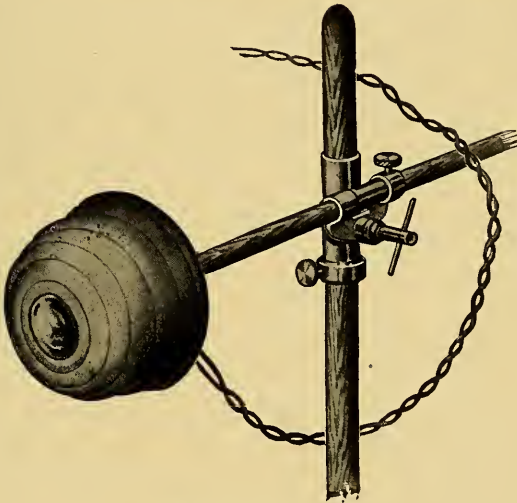

Fig. 38.—The Ultra.



at the office one morning complaining bitterly of great distress about the vulva and to the left side. Upon examination the left labia majora was found badly swollen, red, hot, sensitive and extremely painful. A ten-minute exposure to the ultra-violet light energy from the condenser lamp shown in the cut resulted in immediate relief from pain and sensitiveness, with greatly diminished swelling and lessened heat. As the day wore on all discomfort disappeared and the following morning the labia was practically normal, there being neither heat, swelling, sensitiveness nor pain.

For this same class of cases, the author has used the condenser lamp, placing it directly over the opening of the proximal end of the cylindrical glass speculum and in this way bringing the cervix uteri under the influence of the ultra-violet light energy. The same sense of comfort has followed its use as from light from other sources.

The Field of Ultra-Violet Energy Alone is Limited.—The field of ultra-violet energy alone is comparatively small. When it is a part of the complex of light energy from a source such as the voltaic arc, its field of usefulness is very much greater. In the first instance, the very short and high frequencies which are so little penetrable only are active, but in the latter it is both the ultra-violet and the blue. Freund's experimental work proved that the blue, violet and the ultra-violet, those up to the cadmium line, penetrate the epidermis. The ultra-violet, however, pierce the epidermis and are able to reach the lower layers of the skin only. These penetrant ultra-violet frequencies, according to Freund, constitute a third part of the ultra-violet spectrum as it is known. Bernard and Morgan, it will be recalled, found that it was the energy of the middle third of the ultra-violet spectrum which produced bactericidal action, and that the energy which excited tissue reaction was also in the ultra-violet region. This they did not accurately locate, however.

Inflammatory Reaction and Penetration not Proportional.—The fact should not be lost sight of that the superficial inflammatory reaction established bears no relation to

the amount of penetration. There may be secured for example, a profound penetration, sufficient to promote absorption of a deeply situated exudate, but without corresponding tissue reaction; or on the other hand an intense erythema even to severe inflammation of the skin may be produced without penetrating the true skin.

Choice of Source of Light Energy Dependent upon Pathology to be Treated.—Upon these facts, therefore, depends our choice of a source of light energy. It has been clearly shown that in deep-seated well-organized lupus processes, tuberculous processes, lung or joint, an exudate about a joint or the spinal cord, that a source of light energy rich in the more penetrant as well as the higher and more refrangible frequencies is called for. But if the lesion is superficial and of recent standing, then a source of light energy from the ultra-violet spectrum is sufficient.

If the individual physician who has a static machine or an X ray coil, does not care to add the more expensive arc light mechanism to his equipment he will find that the addition of any one of the ultra-violet or spark condenser lamps described will render him good service in many recent and superficial conditions. It will be an addition to a surgical armamentarium, placing in the surgeon's hands a simple portable inexpensive mechanism the use of which will tend to facilitate the healing of both wounds and contusions, of simple joint injuries, lacerated wounds, venereal ulcers, in fact any of the conditions referred to. It must be remembered, however, that it will only be of avail in recent and superficial growths.

Brush Light or Discharges in Skin Conditions.—Brush light or discharge has been used by a great many operators in the treatment of skin conditions, and while much may be accomplished by its use the results are only obtained after a very long time. Freund substantiates this statement from his own experience.

It has long been recognized by those habitually using static electricity, that from its general administration,

patients with various skin affections, eczema for example, have recovered.

But not until the development of light therapeutics in skin conditions by Finsen and his followers was the nature of the active energy understood or appreciated.

Technique the Same as with Carbon and Iron Arcs.—The technique of applications is the same with the spark condenser or ultra-violet lamps as with the carbon and the iron voltaic arcs. As the ultra-violet frequencies do not penetrate the skin it is necessary to dehæmatize the tissues as for the use of the concentrated energy of the arc. To this end compression may be used or adrenalin diffused cathodically at the will of the operator. It is difficult to draw hard and fast lines between the energy as manifested from different parts of the spectrum but in these condenser lamps it is practically a question of pure ultra-violet frequencies alone.

Pemphigus Neonatorum.—In the summer of 1903 the author was consulted by the father of a boy aged 9, who from infancy had had constantly recurring attacks of a skin disease, followed by complete desquamation. The consultation was for the purpose of knowing whether the use of light energy offered any hope of recovery, for recourse had been had to every known remedy at the hands of skilled physicians and dermatologists without success. The use of a chemically active light energy was advised, but owing to the fact that the patient was very frail it was not thought best to bring him to New York during the summer. Meanwhile Dr. C. R. Dickson,<sup>1</sup> who had referred the patient to the author, added a spark condenser lamp with iron electrodes to his equipment to be used with an alternating current.

Between July 16 and August 11, 1903, the patient was exposed five times to this source of light energy. In the latter part of December, 1903, the father reported that the child remained comparatively well. Here the active energy was that of the ultra-violet frequencies. There are two rea-

---

<sup>1</sup>Dr. C. R. Dickson, Toronto: Personal communication.

sons why these very little penetrating, but very precious frequencies, with their ability to shake up or agitate little things in their path, bacteria, for example, sufficed. (1) The age of the patient which meant, aside from the advantages usually pertaining to youth, a soft tender skin, and (2) the nature of the disease itself with its ever-recurring desquamation and formation of a new skin, serving as it did to increase the softness and, therefore, penetrability of the skin by the ultra-violet frequencies.

As the disease is a rare one in this country, the following conclusions of Eustis,<sup>1</sup> who has made a recent study of the subject may be of interest and service.

(1) In cases of pemphigus a diplococcus can be isolated from the contents of the bullæ.

(2) This diplococcus when injected intravenously into the rabbit will cause death.

(3) A diplococcus removed from the blood of the rabbit and identical with that obtained from a case of pemphigus vulgaris, when injected into the pig (*Sus Scrofa*) produces a pustular eruption in the latter animal attended with a mild constitutional disturbance.

(4) Arsenic is the main remedy to be relied upon in the treatment of pemphigus vulgaris.

The necessity of acting directly upon the blood in pemphigus is very apparent, and the main remedy in the disease—arsenic—is one noted for its power to increase the oxygen carrying capacity and number of red blood corpuscles. Hence the value of ultra-violet frequencies with their affinity for oxygen and consequent stimulus to the oxygenating power of the blood. Every known remedy had been used in the case reported, arsenic among others but without result.<sup>2</sup>

---

<sup>1</sup>A Case of Pemphigus Vulgaris with Some Observations on its Bacteriology, A. C. Eustis, B.S., Ph.D., M.D.. American Medicine, April 14, 1904.

<sup>2</sup>Subsequent to the preparation of this chapter the following detailed account of this case was furnished the author by Dr. Dickson.

Case. Pemphigus.—1903, June 24. Consulted by father of patient at advice of Dr. Grover W. Wende of Buffalo, N. Y., for opinion as to utility of phototherapy. Owing to extensive character of lesion as described by father, Dr. Dickson suggested that child be placed in care of Dr. Margaret A. Cleaves, of New York, for arc light bath treatment, in order that larger areas of skin might be subjected to treatment at one time than would be possible with the Finsen light or any of its many modifications. Owing to the distance from home and the state of the child's health this was not thought possible by the parents.

July 16. The child was brought to Dr. C. R. Dickson, in Toronto, and the following history was given: J. T., boy, aged 9 years, very irritable since 6 weeks of age, diapers when wet caused much irritation, various remedies, both external and internal, had been resorted to without avail and many physicians had been consulted by the physician in attendance. On June 20, 1901, the boy had been taken to Dr. Grover W. Wende at Buffalo, and an ointment, wash and pills had been prescribed under which there was some improvement. On September 23 the boy was again taken to Buffalo and was seen in consultation with Dr. G. W. Wende and others, who made a blood count and found quality excellent, a microscopical examination of skin was also made.

On December 8 a mild attack of measles supervening, all skin treatment was omitted until the 18th, in spite of which the skin lesion in large measure disappeared, but on the 25th exhibited signs of return. On January 1, 1902, his weight was  $38\frac{3}{4}$  pounds, at later dates it varied, e.g., on February 13 it was  $40\frac{1}{4}$ , while on March 10, 1903, it had decreased to  $35\frac{3}{4}$ . The general condition varied much also.

On July 16, 1903, the date of his visit to Toronto, the child was peevish, irritable and nervous and presented a revolting appearance. The entire scalp was devoid of hair, eyebrows and eyelashes were absent. Upper and lower eyelids were swollen so that eyes could be only partially opened,

conjunctivæ much injected, a purulent discharge excoriating lower lids at canthi, upper lip swollen and excoriated from discharge from nose, ears swollen, excoriated and discharging, and face otherwise much involved in lesion. Lesion also involves both wrists and dorsal and palmar aspects of hands and fingers with atrophy and falling out of finger nails. Both buttocks, groins and sides of chest and the abdomen exhibit the lesion, as also both thighs, hips, knees, ankles, heels, soles of feet, toes. In fact there were few spots of entire body quite free. Papules, pustules and crusts were abundant everywhere, there was much pigmentation and extensive desquamation of cuticle. Thighs were semi-flexed on abdomen, and legs on thighs. From this and the condition of heels, it was impossible for him to stand alone, much less walk properly. No boots could be worn, and his stockings and other clothing had to be removed with the greatest care in order to avoid hurting him from catching on the numerous crusts and scales.

On the occasion of this visit the patient was exposed to ultra-violet rays from an "Ultra" lamp, a form with iron electrodes, and used with the alternating current. No compressor was used nor blanching mixture, the lamp was placed about  $3\frac{1}{2}$  inches from the part to be rayed and moved from place to place with an exposure of 4 minutes to each locality. In order that effects of treatment might be noted more readily, the first exposure was to backs of both hands, left foot heel and ankle, left knee and left side of face. On July 22 the palms of hands, right foot, right knee, right side, and right half of face, were treated similarly. On July 30, August 6 and 11 further treatments were given, five in all. Improvement in condition of skin while slow, was gradual and progressive. Reaction had not been very marked after each séance, but after the last, diarrhœa supervened which proved troublesome, especially in view of the fact that mal-assimilation had always been a prominent feature of the case.

Improvement continued, by middle of September was



walking unaided again, weight also increased from  $41\frac{1}{4}$  pounds on September 24 to  $48\frac{1}{2}$  on March 17, 1904.

In February, 1904, early a slight recurrence manifested itself, chiefly in heels, toes, knees and fingers, and on April 4, he came to Toronto for further treatment. A very great improvement since last treatment was now noticeable. With exception of above localities, which were only slightly affected, the skin was in healthy condition throughout, a profusion of downy hair covered the scalp, eyebrows and lashes were also reappearing, the patient also walked quite well unaided, and continued to gain in weight. He was again treated on April 15 and on June 3, and is to receive further treatment.

A Case of Chronic Pemphigus.—Dr. Max Heim<sup>1</sup> reports two cases of chronic pemphigus in which he has employed the blue light from an arc lamp which produced a very rapid cure after every other known remedy had failed.

The first case occurred two years since, while the second was a recent occurrence; the history of the latter case will suffice for both.

In 1877 the patient had a vesicular eruption of the internal portion of the left forearm following a cut which had taken from eight to ten weeks to cicatrize. At first there appeared small confluent vesicles resting on a red base, containing a clear pale yellow liquid, and producing a burning sensation which caused insomnia. Some bullæ healed, but soon recurred. For nine months the patient was treated with different powders and pomades; the bullæ which slowly healed being always followed by the appearance of new lesions. During 6 months the patient was seen twice a week by Dr. Löbker. After 15 months a complete cure seemed to have been obtained. In 1901 the patient had a new eruption of pemphigus on the third and fourth fingers, which spread to the dorsal part of the hand. The usual therapeutic measures, as well as medicated baths, failed to produce

---

<sup>1</sup>Revue Internationale d'Électrothérapie et de Radiothérapie, Fev. et Mars, 1904, p. 238.

any results. The bullæ became more numerous, attacking the dorsal face of the wrist also, and at the end of 8 months the entire dorsal part of the hand showed very numerous bullæ. These were about the size of a pea, resting on a red base, the interspaces showing desquamation and crusts. Some of the bullæ had purulent contents. The hand was painful, and the general condition bad.

In this case the pemphigus had an intimate connection with hysteria that could not be mistaken. Indeed, it could have been called hysterical pemphigus.

In treating the case an intense light with the arc lamp, blue glass and a reflector were employed. The therapeutic effect of the light was surprising, and manifested itself even after the first application. The bullæ commenced to dry up, and the contents of the smaller ones rapidly diminished. The larger bullæ had been pierced with an aseptic needle before the application of the blue light treatment. After three or four séances a marked amelioration of the conditions was observed. Nine bullæ, which had persisted in recurring, no longer showed themselves. In the space of 12 or 13 days, after 9 séances of light treatment, the cure of the pemphigus was complete.

A proof of the marvellous effect of the local application of blue light was the rapid cure after an exposure of 20 minutes of two small bullæ, which had been inoculated by scratching the right hand with the left. These bullæ, as large as peas, situated between the index and middle fingers, disappeared after one exposure.

This case is analogous to one treated two years ago, and can only be explained by the bactericidal power of light.

It must be admitted, comments Heim, that the local application of the arc light brought about the cure of these cases of chronic pemphigus, reputed to be incurable and almost always fatal, when the affection was still in its early stages.

The author is also indebted to Dr. C. R. Dickson, of Toronto, for the following cases :

Sycosis (Barber's Itch).—Epilation was not resorted to, nor the beard removed. The spots, five or six in number on and below the chin, were swabbed over with adrenalin chlorid solution, 1/10000, and each spot was then subjected to ultra-violet energy for 3 or 4 minutes, the lamp being at a distance of half an inch. Five exposures sufficed, and then days after the first appearance of the lesion no sign of it could be detected. There was no recurrence.

Furuncle on Neck of Child with Suppuration well Established.—After applying solution of adrenalin chlorid as above, ten minutes exposure to ultra-violet energy caused the disappearance of areola of redness and marked lessening of the swelling the following day. After two further treatments of about 5 minutes each on succeeding days no trace of boil could be detected.

Recurrent Carbuncle Aborted in One Case by One Application, in a Second by Two of Ten Minutes.—Both cases occurred in men. In the former the subsequent desquamation of cuticle was quite extensive, as of a severe sunburn.

Itching of Small Lupus Vulgaris Nodule (size of pea) on Face.—The patient was a man and was relieved by one treatment. The lupus disappeared after three 10-minute exposures.

Inhibitory action secured on epithelioma of lip, inoperable, recurrent.

Cases of acne rosaceæ, and also acne vulgaris have been treated with excellent results.

In a case of suppurating cervical gland healing after incision was promoted by exposure to ultra-violet energy. In a case of angioma exposure to ultra-violet energy was made prior to electrolysis of the same resulting in an improved condition of the skin.

Relief of Neuralgia.—Dickson's experience is confirmatory of a mass of clinical evidence as to the beneficial influence of light energy in neuralgic conditions.

---

AUTHOR'S NOTE.—Dr. Dickson writes that in cases of long standing lupus vulgaris he has had excellent results. As these cases are to be reported at Int. Elec. Congress they cannot be reported here.

The Concentrated Energy of the Spectra of Iron-Electric Arcs or Ultra-Violet Frequencies in Syphilis. Syphilis a Sub-Catabolic Disease.—The theory promulgated by Wakefield that syphilis and leprosy are to be regarded as sub-catabolic diseases, not only appeals to the reason but offers the best rationale for the action of therapeutic measures known to be of use. This theory may be briefly formulated as follows:

Disease symptoms, whether the disease is due to a micro-organism or not, are due to toxins or chemical poisons. These toxins or poisons act by reducing the catabolic functions of the body tissues, and the result of such a state of depressed activity is the disease as we know it. This theory only refers to what the author calls the sub-catabolic diseases.<sup>1</sup> Leprosy is regarded as the best example of the extreme condition of catabolic stasis. In the treatment of all these conditions, agents which produce hyperæmia of the tissues are most valuable. To this end many physical agents should prove of great value. Light, massage, oil, inunctions, electricity, mechanical vibration, but of all these agents, light, by reason of its physical laws and physiological action, should be of the greatest benefit. Here and there scattered throughout medical literature, vague references are to be found as to the value of light in its treatment.

As syphilis is a sub-catabolic disease, or a disease of sub-oxidation, the therapeutic indication is for the use of oxidizing agents. In the use of light energy there should be selected a light rich in the frequencies of vibrational activity or wave length, which is capable of being absorbed by the blood. In both syphilis and leprosy, parasiticides, *per se*, however powerful, are of no value unless they are active oxidants. Active oxidants are of the greatest value even if devoid of parasiticide properties. It is upon the blood stream that it is necessary to act in order to secure results. Mercury in the primary stage of syphilis does not even de-

---

<sup>1</sup>Wakefield: New York Medical Record, January 1, 1904. Syphilis and Leprosy as Sub-Catabolic Diseases.

stroy the virus, as is proven by the appearance of the second and tertiary manifestations.

Theories as to the Active Agent in Light and Fresh Air Treatment of Syphilis.—In a paper read before the Medical Society of Berlin, 1898, M. Below<sup>1</sup> reported 122 patients treated by means of arc and incandescent light baths, with 67 cures, 36 improvements and 9 without results. The best of results were obtained in lupus, ulcers of the legs, muscular rheumatism and syphilis. He attributed the action in syphilis to the profuse perspiration produced, and referred to the habit of the natives of Hayti and on the coast of Mexico, who had acquired syphilis, of covering themselves with sand on the sea beach and exposing themselves to the sunlight, as exercising a similar influence. In the discussion which followed the presentation of the paper, Below's theory as to the mode of action was not regarded as the correct one by his confrères. They attributed such curative action as resulted to the heat of the sun's rays, not to the perspiration.

A physician of large experience in connection with extensive mining interests, stated in conversation with the author that his syphilitic patients always did best when they led an outdoor life. To what is the beneficial effect due? Below attributed it to the profuse perspiration induced, his confrères to thermal activities and the mining physician associated it with out-of-door life. That all these conditions are beneficial goes without saying, but so to speak, what is the active principle at work and how does it act?

Theory as to the Physical Action of Ultra-Violet Energy as Applied to Syphilis.—To understand physiologic action and consequent therapeutic result necessitates an equal understanding of the physical nature of the agent and the laws governing it. It is only necessary to refer to the spectrum composed as it is of a very great range of frequencies capable of producing chemical, luminous and thermal ef-

---

<sup>1</sup>Below, *Revue Internationale d'Électrothérapie*, Mar., Apr. and May, 1898. Quoted by the author in "The Electric Arc Bath." *Transactions Am. Electro-Therapeutic Ass'n*, 1898.

fects, when all visible frequencies are used, and more intense chemical effects when mechanisms are so arranged as to give not only all the visible chemical frequencies, but the invisible or ultra-violet as well, to clearly establish the manner in which light acts to cure a disease like syphilis. If the curative action depended only upon the establishment of free perspiration, or upon the thermal activities, the methods practiced by the natives of the countries mentioned would, by reason of results, have become an established one. Such is not the case. As the disease is one uninfluenced by parasiticides, and represents a condition of catabolic stasis, indicating the need of powerful oxidants, then that part of the spectrum which is capable not only of producing oxidation, but of being absorbed by the blood is indicated. To this end, the chemical frequencies and their mode of action demand our attention.

Ultra-violet rays have a great affinity for oxygen, and the fact that the blood absorbs these rays better than any other tissue, renders their application in a sub-catabolic disease, like syphilis, a rational one.

In the rhythmic flow of the short high frequency vibrations of light, both of the visible and invisible chemical region, but especially of the invisible or ultra-violet, there is a rate of vibration or oscillatory movement which is in harmony or synchronism with the rate of vibration or swing of the molecules of oxygen. By the penetration of these frequencies, and their great affinity for oxygen, the red blood corpuscle, the oxygen carrier of the blood, is immediately acted upon. As a result of their action, a stimulus is imparted to the life and function of the corpuscles of the locality treated, increasing thereby, not only the amount of oxygen carried by the individual corpuscle but by the entire blood stream. Just as each individual wave of light made up of its oscillating corpuscles receives an impetus from the impingement of the succession of corpuscle upon corpuscle, causing not only each other to swing but another and another, so the movement established by the oscillatory action

of the light wave upon the oscillatory movement of the oxygen molecule of the red blood corpuscle is not confined to the immediate locality acted upon, but extends that influence ultimately to the entire circulation. This means increased chemical action or oxidation. In other words, the light energy through its physical action is converted into chemical energy. An increase of red blood corpuscles means increased leucocytosis as well as increased absorptive activity. There is a loss in the energy of oscillation the further removed from the site of application, and just as the energy of the ripple on the water caused by dropping a pebble or stone therein is diminished by distance, so the effect of a single local application must be very slightly felt at a distance. As the dropping of successive pebbles will maintain the energy of the ripple, so will successive applications of the light energies maintain the oscillatory swing of corpuscles and correspondingly increased chemical activity, until the entire circulation is influenced and the lesion controlled. This should be equally true in the treatment of a systemic condition as in that of a local lesion, a tertiary syphilitic ulcer, for example. The normal functions of the living organism are accentuated, and the fight begins, which, with skilled, sufficiently long and frequently repeated applications of light, continued over sufficient length of time, results in the overthrow of the enemy. If the impact is not that of the same rate of oscillation, the stimulus imparted may not only be unproductive of good, but harmful as well. From the irregular, disorderly and infrequent rate of vibration of the Roentgen ray in the case detailed below, there was no effect produced, therefore it stands to reason that the necessary stimulus to the oxygen-carrying power of the red blood corpuscle was not imparted. In an acute syphilitic lesion, a primary chancre, the action of the latter was, in a case reported to the author, of such a nature as to cause an intense inflammatory action, so intense as to cause some alarm on the part of the physician as to the outcome. In the illustrative case which follows, there was no perspiration

induced, no thermal frequencies of light used, specific medication had been administered and the Roentgen ray used for a period of two months without effect. The result secured was due entirely to the action of cold light; in other words, to that part of the spectrum chemically active, blue, indigo, violet, and especially ultra-violet, as a water-cooled iron electrode lamp was used, and iron gives the maximum of ultra-violet frequencies.

Tertiary Syphilis.—December 21, 1904. Mrs. W., age 30, married, no children, never pregnant. Father living, age 73. Mother dead at 53, "menopause." Patient one of eight children, all well. Health always good, well at time of marriage and since until the present trouble. Husband is also in good health, but had an operation for hemorrhoids five years since. In June, 1903, patient awakened with eye swollen, physician called, and was under his care for three months. The tissues about the eye were swollen and red, but she suffered no pain. The diagnosis made by the physician in attendance was that of poisoning from insect bite. In August, 1903, the swelling under the eye was opened, discharging pus freely. In December, 1903, she was operated on for a "fistulous opening underneath the right eye." In May, 1904, she began to have trouble with her nose. Noticed it was very much swollen. It grew gradually worse. In October a large ulcerated sore appeared on the upper lip. On December 20, when first seen, bridge of nose broken down; septum perforated, ulceration of left nasal cavity, characteristic discharge. Lip swollen, indurated, dusky red, ulcerated area of size of nickel. Hole with clean-cut edges into which forefinger could be laid. Discharge, sluggish circulation. At the time of coming under care, the patient had been on mixed treatment for over two months and had also had from 12 to 14 exposures to the X ray at intervals of two days each. Each X ray exposure was followed by the use of the brush discharge from a static machine. Very little improvement, if any, was noticed from the combined use of the X ray, brush discharge and mixed treatment. December 21,



1903, patient came under the author's care, and treatment by means of the chemical frequencies of light was instituted.

The water-cooled iron electrode lamp, shown in Chapter XII., modelled after the one devised by Sophus Bang, was used. Treatment was given twice a week only. Before each treatment the lip was carefully freed from the crusts due to the discharge from the ulcerated area and from the nose, by the use of a peroxid of hydrogen solution. Firm pressure was made upon the part with the compressing lens of the lamp, to secure the necessary anæmia, and the light applied at the first sitting for 5 minutes only; subsequent exposures were 10 minutes each in duration. Slight reaction was established by first exposure, marked from second treatment, followed by diminution of the induration, swelling and discharge. The sore began to take on a healthy appearance and at the end of three weeks was absolutely healed, only slight redness of skin noticed. By the end of the fourth week, this redness had passed, and the skin was smooth, of normal coloring and without any indurated scar tissue whatever. There was a modification of the discharge from the nose with the healing in the lip, but treatment was directed to the nasal cavity after the healing process was established in the lip. At first, the light from the Marine Searchlight, Fig. 23, was projected into the nasal cavity. With the establishment of improvement, a small incandescent light was carried directly into the nares and kept in position for 5 minutes to each naris. Three such exposures were made, with the result of cessation of the nasal discharge, and healing of the mucous membrane around the perforation. At the time of her last visit, January 28, 1904, the nose, as well as lip, was absolutely well. There remained the white and glazed appearance of the nasal mucous membrane about the perforation and the deformity, to testify to the nature of the condition from which she had suffered. The interesting features of this case are (1) the history. If the patient is to be believed, infection came from an insect bite. (2) The infrequent treatments, but two a week; (3)

the improvement in the nasal ulceration as evidenced by the lessened discharge and appearance of the mucous membrane from the application of the light to the lip only; and (4) the intense chemical activity of the light from the water-cooled iron electrode lamp. This was a condition eminently suitable for a light rich in the violet and ultra-violet frequencies, but not necessarily a light of great quantity. By the oscillatory swing of the corpuscles of the chemical waves of light, especially the precious ultra-violet, the oxygen molecules were made to vibrate more energetically at their own rate, and the influence extended not only to the oxygen carriers of the immediate locality, but to those of the nearby circulation, as was evidenced by a beginning improvement in the nasal mucous membrane before a direct application of light was made thereto.

Strebel<sup>1</sup> reports the healing of venereal warts with three exposures and venereal ulcers with several exposures of half an hour each, utilizing the ultra-violet frequencies from a spark discharge, or the condenser lamp. A similar lamp is shown in Fig. 35. As the spark both from a static machine and a high potential and frequency coil is rich in ultra-violet frequencies, this little lamp is very useful, where deep penetration and large quantity of light are not needed.

M. Sörgo<sup>2</sup> reported to the Vienna Society of Internal Medicine, two cases treated by means of concentrated solar light, the one a well-marked case of tubercular laryngitis, the other a case of syphilitic laryngitis. He concentrated the solar rays by means of a laryngoscope upon the ulcerated mucosa of the larynx. Thirty exposures were made, each lasting about an hour. The ulceration cicatrized and the vocal chords resumed their normal color.

The same treatment failed in a case of syphilitic laryngitis. Uniform results do not follow uniform methods in

---

<sup>1</sup>Die Physiolog. Wirkungen der Polentl. Sitzungsber. d. k. Akad. d. Wissensch. in Wien, Naturw. Klasse, Vol. CIX., Part III., 1900, p. 652.

<sup>2</sup>Revue Internationale d'Électrothérapie, Jan., 1904. Abst. from article by M. Romme, Presse Medicale.

every case. This may be a matter of the individual, and one can but question whether the failure to secure healing in the syphilitic case was not due to the absence of the ultra-violet frequencies. Sunlight, although rich at its source, is deficient in the ultra-violet frequencies at the earth's surface, while the electric arc, especially with iron electrodes, and also the spark light is very rich in them. Single failures nor single successes do not make a rule, but the author believes a source of light rich in ultra-violet frequencies, a more powerful oxidant, might have secured a better result.

The chemical frequencies of light have been shown to be of value in œzema also. The relation which the condition bears to syphilis indicates the same mode of action.

By the use of the arc light projected into the nasal fossæ through the nares dilated for the purpose, or sometimes concentrated upon tubes of crystal introduced within the fossæ, M. Dionisio<sup>1</sup> has observed that where the treatment was administered regularly, there was a remarkable diminution of the secretion, crusts and fœtid odor. Dionisio states that he does not at this time dare affirm the permanency of the results obtained.

Ultra-Violet Light Energy in Syphilitic Chancre, Gummata, Etc.—Freund<sup>2</sup> reports that G. Barbensi and Strebel<sup>3</sup> treated primary syphilitic chancre, gummata and soft chancre with concentrated arc light energy and also with iron electrode and spark condenser lamps, utilizing in the two latter mechanisms the intense chemical activity of the ultra-violet frequencies, as has been considered by the author under syphilis.

While they found that the local lesion in the case of primary chancre heals quickly under the influence of the ultra-violet light energy, the secondary eruptions were not thereby prevented, nor in the opinion of the author should

---

<sup>1</sup>Dr. Ignozio Dionisio, *Gasette Medica Italiana*, No. 6, 1902.

<sup>2</sup>Freund: *Radiotherapy*, p. 512.

<sup>3</sup>Revisita Critica di *Clinica Medica*. Quoted by Foveau de Courmelles in *L'année Électrique*, 1902, p. 392.

they. The entire blood stream must be acted upon and while it is indirectly and to a degree influenced by such a topical application, the expenditure of light energy is not sufficiently extensive or energetic to influence it in its entirety. To this end every square inch of the superficies of the body should be brought under the influence of the powerful energy of concentrated arcs, iron and carbon, from which a beam of 10 to 12 inches in diameter should be projected upon the superficies of the body, or exposed to the action of the non-concentrated energy of powerful arcs in a circuit. In this way the frequencies chemically active would have the power to increase the oxygenating power of the blood supply. Specific medication in syphilis depends upon its power to increase oxidative processes, and while the author would both use and recommend the use of mercury and the iodids according to the stage of the disease in addition to both topical and general treatment by light, she can but question whether the action of light alone, skilfully applied, would not suffice in a good many cases. It is recommended that those who have the equipment and experience, as opportunity offers, make observations in this regard, watching closely, however, in order that the patient's future welfare may not be jeopardized from withholding specific medication. There are limits within which this may be safely done. Strebel found that with venereal ulcers two or three exposures sufficed to heal the sores in a few days. He did not observe any evidence of distinct influence on glandular swellings.

## CHAPTER XVII.

Vacuum Tube Discharges, Phenomena and Theory of. Mechanisms,  
Methods of Use and Therapeutic Indications.

### Vacuum Tube Discharges.

While experimenting on the discharge in vacuum it was found by Messrs. de la Rue and Hugo Miller a quarter of a century ago, 1879, that "the stratified discharge in a vacuum tube is simply a magnified form of arc."

To test their theory they made a series of experiments in discharges of various gases at various pressures, with the poles at various distances from one another, and of different shapes. The poles were fixed in a bell jar that could be filled with the different gases and exhausted. A suitable arrangement was made for altering the distance between the poles, and the gases used were air, hydrogen and carbonic acid gas.

In air the pressure varied from 2.6 mm. to 761 mm., the distance varied between 0.54 in. and 6.4 in., the current ranged from 0.01390 weber to 0.04474 weber, and the number of chlorid of silver cells used varied from 10,940 to 11,000. The substance of the electrodes so far as mentioned was brass.

From their experiments they observed that in air the light usually divides itself into at least two and sometimes many parts, with dark spaces between them.

In hydrogen, in some cases, the discharge showed a very definite stratification. In carbonic acid, when the pressure was very small, there was very little evidence of stratifica-

tion; but in both cases the discharge was divided, as in air, into light and dark parts.

It was found that whenever contact was first made the pressure in the bell jar increased more than could be accounted for by the rise of temperature of the enclosed gas. The moment contact was broken the pressure fell almost to what it had been before the contact was made, the slight increase being due to rise of temperature. Experiment showed that this increase took place equally at both terminals. They concluded that it was to be accounted for by the projection of the gas molecules by electrification against the walls of the glass vessel, producing thereby effects of pressure, which, however, are distinct from the molecular motion induced by heat.

Because of the fact that the electric arc is so commonly used as a source of light energy for therapeutic work, the summary of De la Rue and Miller, as it concerns the electric arc is given prefatory to considering the physics of vacuum tubes and their therapeutic uses: "When the discharge takes place there is a sudden dilation of the medium in addition to and distinct from that caused by heat. This dilation ceases instantaneously when the discharge ceases."

"The electric arc and the stratified discharge in vacuum tubes are modifications of the same phenomenon."<sup>1</sup>

This little historic sketch showing the first conception of the unity of the phenomenon of a vacuum tube discharge with the electric arc, which in turn owes its conception to the spark discharge between the terminal balls of the discharging rods of a static machine (see page 83), cannot fail to aid in a comprehension of the unity of all these various phenomena. In the present instance, however, the electrical discharge takes place in tubes of varying degrees of vacuity. In the first place no electrical discharge has ever been passed through a perfect vacuum. Of the many forms of vacuum tubes in use both for experimental and medical work none

---

<sup>1</sup>The Electric Arc: Ayrton.

can be regarded as possessing a perfect vacuum. The degree of vacuum varies according to the purpose for which the tube is constructed. The most efficient X ray tube for example must be of very high vacuum. Discharges through vacua are obtained from the tubes variously known as Crookes tubes, X ray tubes, Tesla tubes, mercury vapor tubes and Geissler tubes. Those which concern this subject especially are tubes of comparatively low vacuum, commonly known as vacuum tubes for medical use. Geissler tubes of commerce are also used for the same purpose and therefore find a place herein.

Dry Air and Other Gases at Ordinary Pressure Non-Conductors of Electricity.—These act like glass, mica and other insulators. Under very strong electric pressure they break down, i.e., overcome their potential difference, and give rise to disruptive discharges, for example, as a thick plate of glass may be pierced by the discharge of a powerful condenser. This may happen with the Leyden jars in circuit, by placing the piece of glass between the terminal balls of the discharging rods of a static machine or of a powerful coil. In fact it has happened in the author's experience in the patient's circuit, i.e., with the machine grounded, which after all is but a Leyden jar discharge, the disruptive discharge passing through the patient's eyeglasses, which unknown to the author were contained in her pocket, in the path of the localization of the spark discharge.

Insulation of Gas Depends upon its Pressure and Density.—The insulating power of a gas increases with its pressure and density. Liquid and oxygen are almost perfect insulators. The insulating power of a gas is decreased by the presence of moisture in the form of vapor or mist. This is supposed to be due to an ionizing of the gas. Ionization is facilitated by diminishing the pressure and density of the gas, until a certain density is reached beyond which conductivity again decreases. This diminution of conductivity is probably from the lack of a sufficient number of ions to carry the current.

Phenomena in a Vacuum Tube.—When an adjustable spark gap of an induction coil or a static machine is connected in parallel with another spark gap in a glass vessel from which the air can be gradually exhausted the appearance of the discharge varies as the density decreases. Should the poles of the exterior spark gap be nearer than the electrodes within the tube, there will be observed at first a series of white, sharp, blinding, zig-zag disruptive charges. But as the density within the tube decreases, the discharge will be shifted from the external to the internal circuit, i.e., the electrodes within the tube. Instead of the former disruptive discharge, the electrical discharge assumes a continuous brush-like glow of great beauty, the color of which will vary with different gases and also with different degrees of vacuity. At this juncture it may be well to point out that in addition to the color of the continuous brush discharge within the tube there will be observed at the superficies of the tube other colors varying from a greenish yellow to a green and sometimes a blue dependent upon the kind of glass used in the construction of these tubes. This brush-like glow becomes more and more a distinct stream of light, passing directly from the anode to the cathode, turning all the numerous curves and corners in the tube as well as around obstacles interposed in its path. As the contained gas diminishes in density, its conductivity gradually increases. This is readily shown by the need of a shorter external spark gap. When the tension of the residual gas is about 1-10 inch of mercury, showing a density of about 1-300 of the normal the best results are obtained. When these conditions are maintained the poles of the external circuit may be brought within a fraction of an inch of each other without a spark passing, indicating that the way of least resistance is in the tube itself. As the rarefaction of the air proceeds below this point the resistance increases, as is shown by the necessity for lengthening the spark gap to prevent the sparking taking place in the external circuit.

Appearance at the Cathode and the Anode.—When this



rarefaction is about 1-300, the cathode is surrounded with a faint bluish light, while from the anode there proceeds a stream of peach-blow colored light. This latter is separated from the glow light of the cathode by a dark space, the thickness of which increases as the rarefaction increases. The stream of light which proceeds from the anode at first appears continuous, but upon reflection upon a rapidly rotating mirror it is seen to be separated or made up of little discs of light separated by dark spaces, which present a wavering appearance, now closing up and then separating. By increasing the vacuum these striæ are distinctly seen without a mirror. By placing volatile liquids within the tube, alcohol, for example, these effects of stratification are increased.

Anodic Stream a Conductor.—The stream of light from the anode behaves like a flexible, movable conductor when carrying a current; it is attracted and repelled by a magnet. It tends to curve around the magnet, just as a flexible wire will wind itself around a magnet, if free to move. If the vacuum tube be made with a hollow core into which a bar magnet can be placed, the light stream will revolve around the magnet. By a reversal of the poles of the magnet or a reversal of the direction of the current through the tube, the stream of light will revolve in the opposite direction. The direction of the rotation shows that the light is made up of positively charged ions, moving forward to the cathode. The discs of light are caused by the collision of the ions, and the dark spaces by their mean free paths, that is, the distance they travel before colliding. The thickness of the dark space around the cathode increases as the rarefaction increases and the striated light stream gradually recedes toward the anode.

The Cathode Rays.—It is when this rarefaction has reached about one-millionth of an atmosphere that the colored striated light stream has entirely disappeared. Apparently it has been driven back by the stream of dark rays from the cathode. An entirely different set of phenomena now appears. But little light is given forth by the tube under these circumstances and no color, save that referred to on

a previous page, caused by the fluorescing of the glass. The color varies with the different kinds of glass but is generally of a yellowish green. The position of the anode becomes a matter of indifference. There must be one somewhere in the tube, but it may be carried from one point to another without producing any effect upon the character of the discharge. The rays proceeding from the cathode pass in straight lines until they strike the end of the tube or some object interposed in their path. The point where they strike is called the anti-cathode. These dark rays emanating from the negative electrode are those known as Cathode Rays.

The peculiarities of these rays have been set forth in Chapter I., under the manifestations of light energy.

It was to explain these facts that Thomson directed his investigations a few years since, 1897, the results of which in relation to the cathode rays are epitomized under that head. Not only do they explain the phenomena of the cathode rays but of the solar and stellar atmosphere, of that of an electric arc, of the action of a spark discharge upon the air as well as within a vacuum.

The phenomena above described apply to a Crookes tube up to the point of the production of the X ray.

Geissler Tubes.—The brilliancy and beauty of the stratification of the electric light are most remarkable when the discharge of the Ruhmkorff coil or the static machine takes place in glass tubes containing a highly rarefied vapor or gas. These phenomena, which were originally investigated by Gassiot, are produced by means of sealed glass tubes first constructed by Geissler, of Bonn, and generally known as Geissler tubes.<sup>1</sup>

These tubes are filled with different gases or vapors, and are then exhausted so that the pressure does not exceed half a millimetre. Two platinum wires are fused into the glass at the respective ends of the tubes. When the two ends of a Geissler tube are connected with a suitable source of E. M. F., a coil or static machine, there are produced

---

<sup>1</sup>Ganot's Physics.

throughout the tube magnificent lustrous striæ, separated by dark bands. These striæ depend for their shape, color and lustre upon (1) the degree of the vacuum, (2) the nature of the gas or vapor, and (3) the dimensions of the tube. This brilliancy of effect is added to by the fluorescence of the glass produced by the electric discharge, which varies in color, according to the quality of the glass.

Color and Shape of the Striæ with Carbonic Acid.—When carbonic acid is used, under a pressure of a millimetre, the color is greenish, and the striæ have not the same form as in hydrogen. When the tube contains nitrogen gas, the color is yellow. The light in a Geissler tube depends upon the nature of the gas or vapor, not upon the substance of the electrodes.

Spectra of Geissler Tubes Depend upon the Nature of the Gas Contained Therein.—The lights furnished by the Geissler tubes give varying spectra according to the gas with which they are filled, nitrogen, hydrogen, oxygen, and the hydro-carbons when they are decomposed by a prism. When connected with a source of high potential electricity, high tension coil or static machine, and held before the slit of the spectroscopie for an analysis of their radiant energy, it is found that no two gases vibrate in the same rates, and, therefore, no two give the same colors.

Identity of Vacuum Tube Discharges with the Aurora Borealis.—This spectroscopic analysis of the radiance of Geissler tubes is one of great interest in the relation it has to the aurora borealis. There is shown in these high vacuum tubes all the rates and colors ever seen in auroral streamers. Columns and curtains are shown in rapidly oscillating electrical discharges. There is no new mode seen in the auroral light. In this connection it may be of interest to note that nine lines in all have been seen in the auroral spectra, but only seven at once. The brightest is the yellow green, although in one aurora Perry saw the red brightest in a curved streamer. A magnetic storm was raging at the time. Another observer noted the green-blue flickering in all parts

of the spectrum at the same display, February 4, 1872. The great aurora of April, 1871, was so brilliant that measures of its spectral lines could be made with a micrometre, and nine were measured.<sup>1</sup>

The green line of wave length, 5,571, is present in every aurora while the others vary with different apparitions. This is termed the aurora line.

According to Vogel, the red line in the auroral spectrum is due to nitrogen, and also the two others toward the violet. The third line in the spectrum of oxygen appears as the fifth in the spectrum of an aurora. Most of the lines are due to the air and its gases. There are iron lines, however, in the auroral light. The wonder of the existence of iron vapor in air is to be explained by the fact that vapor is made of exceedingly fine particles, so fine that they are able to exist in the higher regions of the air against gravity for some time, or in a continual precipitation of iron dust, at least, during the period of an auroral display. Fine particles of iron were caught from space by Nordenskjöld,<sup>2</sup> who set up vertical tin tubes in the arctic regions. The aurora is an electric-magnetic disturbance and iron the most magnetic metal.

When the electric pressure, the E. M. F., of a coil or static machine is passing through Crookes or Geissler tubes, by placing them in a magnetic field, i.e., between the two poles of a powerful magnet, there is a great intensification of all the effects. The colors of the lights in the tubes can be changed to imitate the colors of the aurora by simply increasing or decreasing the strength of the invisible magnetic field in which they are placed.

Relation of Current to Change in Color of Stratification.—A change in the current often produces an entire change in the color of the stratifications as, for example, in hydrogen. Here, the change is from blue to pink, due to rise or fall of current.

---

<sup>1</sup>Larkin: Radiant Energy.

<sup>2</sup>Ibid.

Regularity and Distinctness of Striæ Governed by Regularity of Electrical Discharge.—When the discharge is irregular, and the strata indistinct, the latter will become both steady and distinct upon an alteration in the strength of the current. But even when they are apparently steady and permanent, a telephone will reveal a pulsation in the current.

Color of the Discharge Depends upon the Degree of Rarefaction Even in the Same Gas.—The least resistance to the discharge in hydrogen is at a pressure of 0.642 mm. or 845 M. (symbol for the millionth of an atmosphere). This is when its brilliancy is at its greatest. At a given pressure, air offers a greater resistance than hydrogen; a spark which passes in hydrogen across a distance of 5.6 mm. will go across a distance of only 3 mm. in air. At a pressure of 62 mm., corresponding to an atmospheric height of 12.4 miles, the electric discharge has the carmine tint observed in the auroral display; at a pressure of 1.5 mm., corresponding to a height of 30.96 miles, it is salmon-colored, while at a pressure of 0.8 mm., equal to a height of 33.96 miles, it is of a pale white. The discharge has the greatest brilliancy under a pressure of 0.379 mm. This represents a height of 37.67 miles. These facts as to the degree of pressure giving rise to the various colors of these tubes will enable one to judge of the degree of vacuum of the vacuum tubes in daily use.

Luminescence of Vacuum Tubes.—This is a property of vacuum tubes which depends upon (1) a certain degree of rarefaction of the internal atmosphere of the tube, whether the tube contains conducting filaments or not, (2) the maintenance of incandescent lamps by current of high frequency. In the first instance the luminous effects were obtained by Nikola Tesla in the course of his experiments with currents of high frequency and high potential.

At one time the luminescence of vacuum tubes bade fair to be of practical use for purposes of illumination. This was after Tesla's original experiments and the experimental work done by McFarlane Moore. Moore carried his demon-

strations so far as to beautifully illuminate a small chapel which formed a part of the exhibit of the New York Electrical Exposition at Madison Square Garden a few years since. The light was soft, white but not glaringly so, and diffused by means of vacuum tubes arranged around the cornice of the room. With these tubes the current was let directly in by conducting contacts, and not lighted by a process of induction as with the original Tesla tubes. This method gave great promise of commercial possibilities, which, however, have not yet been attained.

Luminescence in Mercury Vapor Tubes.—There may be added to this category the tubes of mercury vapor known in commerce as the Cooper-Hewitt Mercury Vapor Lamps. In this instance the conduction of electricity takes place by reason of mercury vapor. The reactions taking place in the mercury vapor vacuum tube or lamp may be divided into three groups: (1) those taking place at the positive electrode, (2) those taking place at the negative electrode, and (3) the behavior of the vapor itself.

The conduction of electricity through a vapor is undoubtedly brought about by streams of positively and negatively charged particles, each leaving its respective electrode and travelling toward the other. These streams of charged particles under proper conditions form a luminous column. This varies in character (1) with the current passing, (2) the vapor pressure, and (3) the size of the enclosing vessel.

Eliminating the electrode effects Mr. Hewitt found that the behavior of the mercury vapor under the conditions of this lamp or tube, may be stated as follows: the resistance per unit length of the vapor column, (1) decreases with an increase in the diameter of the tube, (2) with an increase in the current flowing, and (3) with a decrease in the vapor pressure. The watts absorbed per centimetre of length vary of course with the current and resistance. Other things being equal, they increase with an increase in current, with an increase in the diameter of the tube, and with an increase in the vapor pressure.

Luminous Efficiency.—The luminous efficiency of the lamp varies with other conditions; but there is a certain ratio between vapor density and current at which the ratio of light given out to the energy absorbed is a maximum. The resistance of the vapor increases if the tube be placed in a magnetic field. It is believed that the results obtained with mercury vapor will prove true of saturated vapors in general.<sup>1</sup> The spectroscopic analysis of this light has been given in a previous chapter. Rich as it is as a source of ultra-violet energy, this ultra-violet energy is, in common with that of other vacuum tube discharges, of no value in therapeutics above 30 micro-centimetres because of the glass enclosing tube.

Mercury Vapor in Vacuum Tubes of Fused Quartz.—In these experimental tubes not only the light produced in the tube, but the light emitted, by reason of the quartz enclosing tubes, is very rich in ultra-violet energy.

Fluorescence a Phenomenon of Vacuum Tube Discharges.—Fluorescence is so commonly associated with light that the fact of its production by the discharge of a vacuum tube has been construed at once as an evidence that these tubes are sources of great ultra-violet energy. In fact, this explanation of this phenomenon has been carried to such an extent that vacuum tubes of glass to be excited by a coil or static machine are constantly made and sold to the profession as a source of ultra-violet energy. These ethereal vibrations or oscillating swing of light corpuscles are not the only agencies capable of initiating it. The same phenomenon appears even more markedly when a fluorescible substance is introduced into the interior of a Crookes tube. It was proven by Tommasina<sup>2</sup> in his experiments made in 1900 that currents of high potential, in passing between electrodes of aluminum or magnesium through a glass tube filled with water or alcohol, give rise to similar luminous effects. By the fluorescence thus produced not only the in-

---

<sup>1</sup>E. World and Eng., Dec. 19, 1903.

<sup>2</sup>Medical Electrology and Radiology, May, 1904.

terior of the glass tube and its contents are illuminated but objects in its immediate vicinity are made visible. The degree of illumination thus produced depends (1) on the intensity of the current, (2) on its constancy, and (3) on the source from which it is derived. When a static machine is used, a continuous steady effect is obtained, with a spark coil in the other hand a bright but pulsatory illumination is produced. In the latter instance the number of flashes is proportionate to the frequency of the interruption of the current in the primary circuit. The anode is rendered luminous by the extra current at "closure," the cathode at "break," thereby proving that the fluorescence is anodic. Light produced in this manner is incapable of exciting a platino-cyanid screen, but is photo-chemically active.

When the surface of the electrodes is unpolished and somewhat oxidized the effects are best seen; the film, which acts as a dielectric, appears to be excited to fluorescence by the passage of the current.

The luminous effects can be still further increased by the use of phosphorescent media, alcoholic solutions of quinin and gelsemin, of the glycerol-alcoholatives of quinin, gelsemin, turmeric, the aqueous solutions of the same substances, or of esculin, fluorescin and eosin.

This effect of vacuum tube discharges is one of high frequency and high potential current, rather than that of the light generated in the tube, as light itself. The phenomenon is seen to a greater advantage when a stream of negatively charged particles, the cathode rays, impinge upon a fluorescent substance introduced into the interior of a Crookes tube. Therefore the ability to excite fluorescence in fluorescent substances with vacuum tube discharges is to be regarded not only as evidence of ultra-violet light but of high frequency discharges in vacuo as well.

The Conductivity of Electricity through Gases.—This has been shown by the brilliant work of Thomson to be due to the action of positively and negatively electrified particles, corresponding to the ion in the electrolytic conduction, which



carries an electric charge, and was named by Dr. Johnson Stoney an "electron."

The electric fluid corresponds to an assemblage of corpuscles, negative electrification, consisting of a collection of these corpuscles; the transference of electrification from place to place being a movement of corpuscles from a place where there is a gain of positive electrification to a place where there is a gain of negative. A positively electrified body, for example, is one which has been deprived of some corpuscles. These corpuscles may either remain free or become attached to molecules of matter with which they come in contact; positive electrification is always associated with ordinary matter, while negative electrification may or may not be, according as the corpuscles are or are not attached to molecules of ordinary matter. Thus in gas at very low pressures the corpuscles are free, but in gases at higher pressures they get attached to the molecules of the gas so that there is not much difference between the effective masses of the positive and negative ions. Although the negative ion moves faster than the positive in gases, the difference is not great.<sup>1</sup>

Theory of Spark Discharge.—Ionization, which is necessary to put the gas into the conducting state required for the passage of the spark, is effected by means of ions, which under the influence of the electric field producing the spark, acquire so great a velocity that when they come into collision with the molecules of the gas through which they are moving they ionize the molecules. In the cases of cathode and Lenard rays ionization of the gas takes place by the rapidly moving ions. Ions in a sufficiently strong electric field can acquire sufficient energy to enable them to act as ionizing agents. This explains some of the phenomena connected with the discharge of electricity produced by the action of ultra-violet light. As the positive ions strike against the cathode, the cathode under this bombardment

---

<sup>1</sup>Thomson: Conductivity of Electricity Through Gases.

emits negative corpuscles—in fact cathode rays. The continuous supply of negative corpuscles comes from the metal of the cathode, stimulated by the positive ions striking against it. The action of the latter ionizing agents is due to their impacts on the cathode. The rapidly moving negative ions, the corpuscles, are more efficient ionizers than the positive ions, which have a greater mass.

The accompanying cut, due to Sir Oliver Lodge, very

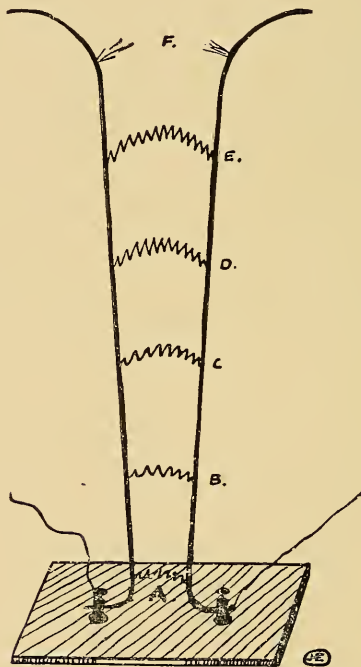

Fig. 39.—Apparatus for illustrating the upward movement of a spark through the ionized and heated air.<sup>1</sup>

prettily illustrates the upward movement of a spark through the ionized and heated air. It begins near the bottom, but by the act of sparking at that level an effluvium or ionized

<sup>1</sup>Sir Oliver Lodge: Archives of the Roentgen Ray, May, 1904.

substance in the air is given off which rises and makes the path easier just above where the spark first appeared. Thus the spark rises, and again the effluvium makes an easier path above it. It runs on up in this fashion until it reaches the top where the wires diverge. They are then too far apart, i.e., the potential difference is too great, for the spark to pass. It breaks off and begins at the bottom again. Each successive spark is just above where the previous one has been. In the ionization of the air an easier path is formed, for the spark rises with it.

Theory of the Discharge through Vacuum Tubes. —The theory of the spark discharge is applied by Thomson to explain some of the phenomena when the discharge passes through a vacuum tube containing gas at a low pressure. The spark discharge originates the ionization of the gas by moving the small negative ions. If, however, the ionization in an electric field not exposed to external ionizing agents, such as Roentgen rays, were solely due to the collisions of corpuscles with the molecules of the gas, a continuous current through the gas would be impossible. To account for the phenomena of the discharge in vacuum tubes it is necessary to have ionization produced by the electric field itself close to the cathode. We shall suppose, says Thomson, that this ionization is produced by the positive ions, and although these require a much greater amount of energy before they can act as ionizers than do the corpuscles, yet the very intense electric field which exists close to the cathode is sufficient to give them, when under its influence they have come up to the cathode, all the energy they require. This might happen in two ways: (1) That the positive ions by collision ionize the molecules of the gas near the cathode; (2) that the positive ions by striking against the surface of the cathode communicate so much energy to the corpuscles contained in the layer of the metal close to the surface of the cathode that they are able to escape from the metal just as they are able to escape from a metal when raised to incandescence.

Whichever of these views is taken, continues Thomson, the consequences will be very much the same; for the strength of the electric field increases so quickly near the surface of the cathode that the kinetic energy possessed by the positive ions, as they arrive quite close to the surface, will be enormously greater than when they are just a little further off, so that any ionization produced by the collision of these positive ions with the molecules of the gas will be practically confined to the layer of gas close to the surface of the cathode. It is possible that the luminous glow which spreads over the cathode is the seat of ionization. Therefore whether (1) the positive ions collide with the molecules of the gas near the electrode or (2) the negative ions start from close to the surface of the cathode, these latter are driven from it by the electric field and soon acquire such velocities that they ionize the gas through which they pass, producing a supply of positive ions which are attracted by the electric field up to the cathode, there to produce a fresh supply of negative corpuscles. The positive and negative ions in the space close to the cathode are therefore mutually dependent; if the supply of either is stopped, that of the other at once fails. This is shown experimentally by an obstacle placed in the dark space of a Crookes tube which throws a shadow, as it were, backwards and forwards. The obstacle stops the supply of positive ions to that portion of the cathode in shadow; it is no longer able to send out negative ions coming from the cathode, the origin of the dark space. On this theory the negative glow is due to the ionization brought about by collisions between molecules of the gas and corpuscles which have started some distance from the cathode. Such corpuscles are the descendants, so to speak, of the corpuscles which started from close to the cathode and which move with very much greater velocity than the glow-producing corpuscles, starting in a much weaker electric field. The corpuscles which start from close to the cathode may, as they are but little absorbed, pass directly through the negative glow. These corpuscles are the cathode rays.

In these discharges through vacuum tubes, when the electric field sinks below a certain value, it can no longer communicate to the corpuscles sufficient energy to make them act as ionizers, so that after the field has sunk to this value ionization ceases, or more accurately it ceases soon after this value is reached, for the corpuscles may retain for some little distance the energy thus acquired in stronger parts of the field and so continue to act as ionizers for a short distance in the weak field. The limit of the negative glow farthest from the cathode marks, according to Thomson, whose theory is quoted, the place where ionization ceases.

Case when the Discharge is not Striated and the Positive Column is of Uniform Intensity.—The corpuscles are continually recombining, so that their number is constantly diminishing, unless there is fresh ionization. If the rates of ionization and recombination are equal, the number of corpuscles will remain constant. Under these given conditions the luminosity will be constant all along the line of discharge and a uniform positive column will exist. If the proportion of the current carried by the negative ions varies at different points in its course the current will be much more deflected by the magnetic field in some places than in others. This is because the negative particles are much more easily influenced by a magnetic field than the positive.

Emission of Rays by Vacuum Tubes.—With the ordinary medical vacuum tubes and Geissler tubes of commerce so far as light energy is concerned, it is only the frequencies of the blue-violet region to which the glass of the tube is transparent. Therefore it is the blue frequencies of the spectrum which are emitted.

If these tubes have a window of quartz sealed in, they may prove a source of ultra-violet energy. It will be recalled that the ultra-violet spectra tends to rise as the temperature increases and these discharges in the low vacuum of the medical tubes ordinarily used are not sources of high

temperature. But if the ultra-violet light is present it will be transmitted through the quartz window. The only such tube which the author has investigated was badly constructed, i.e., the fusing or cementing of the quartz window into the glass, a difficult task, was badly done and the vacuum was correspondingly low. The observed phenomena of the tube were not even comparable with the simple tubes of glass in daily use.

Cathode Rays not Emitted.—Of the two types of vacuum tubes, (1) with leading-in wires and (2) without leading-in wires, the former generate cathode rays, but not the latter. This is because of the necessity for the presence of a target or wire to receive the impact of the positively electrified particles. But as cathode rays are not transmitted through glass it does not matter whether they are generated or not. They can only be conveyed external to the tube through an aluminum window, as was shown by Lenard, when they become Lenard's rays. They concern the physician, therefore, in the relation they sustain to Roentgen rays. It will be recalled that it has been stated that they may be regarded as the parent of the X ray. The latter do not concern us in this connection.

The only frequencies of light or rays emitted by the vacuum tubes for medical work, other than X ray tubes, are those of the blue-violet region.

Mechanisms.—Vacuum tubes for medical use only are constructed of many different shapes and with slightly different degrees of vacuity. Geissler tubes of commerce can be used, but they have no advantage over and above the tubes especially constructed for this purpose. There are two types of vacuum tubes for use therapeutically (1) those having a leading-in wire and (2) those without. In the first instance the wire offers a conducting surface to the terminal end of the interior of the tube for the electrical current. The electrical discharge from vacuum tube electrodes is due to a condenser action, however.

Tubes Containing Conducting Wire.—Tubes with a con-

ducting wire offer an opportunity for a more energetic and uniform conveyance of the electrical discharge than those without. They are useful when it is desired to obtain the effect of the rapidly oscillating electrical discharge as well as that of the light energy.

Tubes Without Leading-in Wires.—With these the electrical discharge is not so much in evidence as the light. The former may produce a considerable sensory disturbance, true electrotonus, when the latter cause very little sensation and the electrotonic effect is less marked.

In some instances, i.e., with some tubes there is no electrotonic effect. This is notably true, the author has observed, when the current from the static machine is passed through a transformer.

With a small Tesla coil placed in circuit with a 12-plate static machine, there was not obtained from either type of vacuum tubes, i.e., with or without leading-in wires, sensory disturbance, electrotonus or fluorescence. The tubes glowed beautifully, but no more brilliantly than when connected directly to the machine. The absence of sensory effect, electrotonus and fluorescence would indicate an absence of the electrical discharge, and under such circumstances the physiological effect should be attributed to the blue-violet frequencies of light alone. When it is desired to use a vacuum tube discharge, without the electrical action, the transformer is placed in circuit, otherwise not. This absence of electrical effect is not true with the transformers manufactured for this purpose, nor has the author found it true with a high tension coil, but with the Tesla coil, which the author has used since 1896, for the purpose of transforming the static current, it is true, having been observed again and again. It is evidently due to the construction of the coil itself, and must bear a relation to the pressure of the static current and the windings and resistance of the coil.

From the medical side at least, there is much in relation to vacuum tube discharges demanding study and investigation.

From both varieties of tubes, however, are to be obtained the action of a chemically active light energy—not ultra-violet but blue-violet—therefore, the effect is twofold, i.e., that of a high frequency discharge, itself next of kin to light, and that of light.

Vacuum Tube Discharges in Therapeutics.—These vacuum tube discharges serve a very useful purpose in therapeutics. The mechanisms may be connected (1) to a high tension coil, (2) to a static machine. In both instances a transformer may be used, but not necessarily. Leyden jars may be interpolated in the circuit of a static machine, but this is not the author's practice. Vacuum tubes may also be used with an interrupter consisting of from 30 to 50 small brass balls separated about one-quarter of an inch, secured

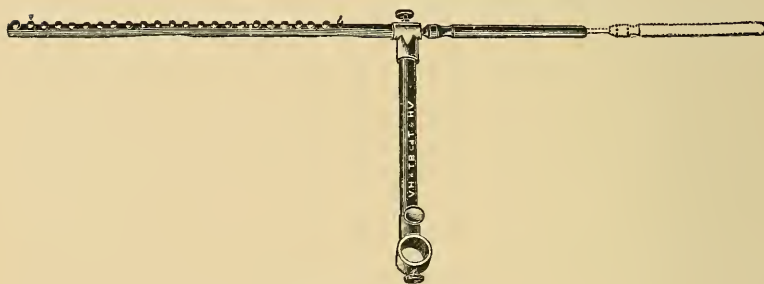

Fig. 40.—Interrupter.

to some non-conducting base (this is very apt to be made of hard rubber, but it becomes heated, and may actually melt, as it were, under the heat generated). This results in a distortion of the rod which renders it unfit for further use. Mica with a combination of shellac is recommended. This mechanism is provided with a sliding rod, which may be moved backwards and forwards, as is desired, thereby increasing or decreasing the number of spark gaps in the circuit. Fig. 40 shows one of these interrupters. This is usually known as the Files Interrupter. By the use of this multiple spark gap, the intensity of the discharge through



the tube is increased. Fig. 41 shows vacuum tubes with leading-in wires (1) for surface contacts, (2) for aural, and (3) for nasal applications. These the author has used daily

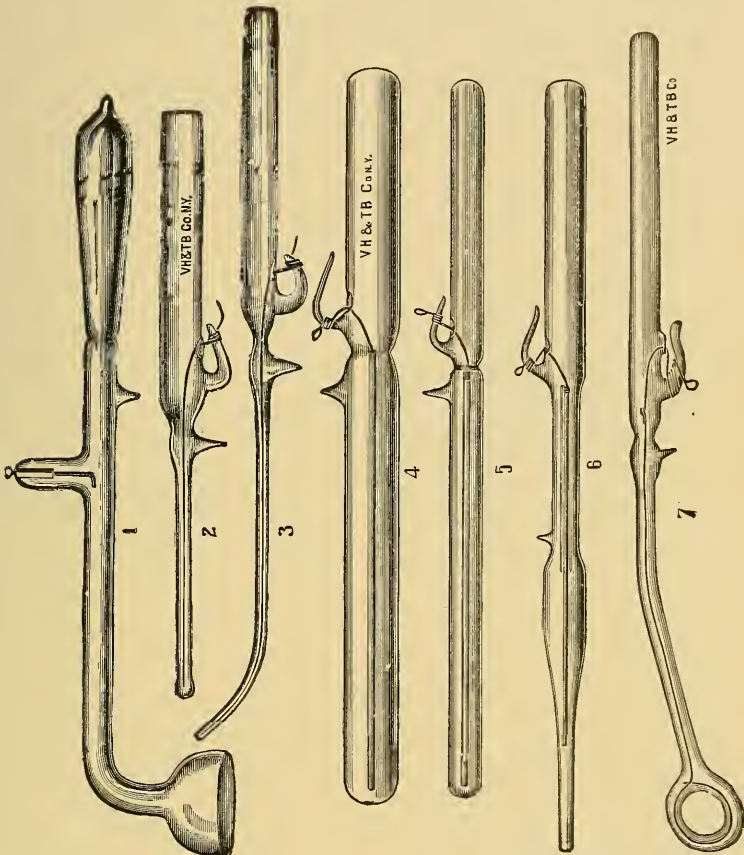

Fig. 41.

for a number of years as well as tubes constructed on similar principles for the vagina-rectum, uterus, urethra, and for tonsillar applications Nos. 4, 5, 6 and 7 of the same figure. Fig. 42 shows a set of vacuum tube electrodes of many different shapes without leading-in wires.

Many of these were devised by Dr. Snow, and they present many points of practical value. Especially is this the case where the part of the tube desired for localization, post nasal, for example, is the seat of the vacuum only, being sealed off from the length of the tube. These permit of

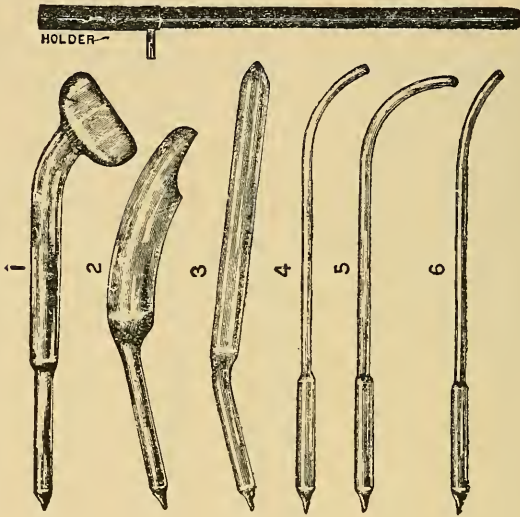

Fig. 42.

application to the ear and nose, both anteriorly and posteriorly, to the tonsil, cervix uteri, rectum, urethra, etc., without producing the sensation of the electrical discharge at any point save at the exact point where localization is desired.

Negative Terminal Richest in Chemically Active Energy.—As the terminal of the negative discharging rod is the seat of the most intense chemically active energy, connection should always be made with it. The object to be obtained is the production of light of as short and high frequency of vibration as the generating source can achieve. But under no circumstances is this ever ultra-violet energy outside of the tube. It is that of the longer waves of the

blue-violet region. These are very active chemically, and produce an image on photographic paper by their own light in a few seconds, almost instantaneously, at a distance of 2 to 3 inches, as the author has shown experimentally.

The negative brush of a Geissler tube is a source of intense chemical activity, and the rays are very pure violet. In an experimental study of these tubes some two years since, Leduc attributed the chemical effects largely to ultra-violet rays. It must be remembered that even though ultra-violet energy is generated in vacuum tubes, that it does not pass external to the tube in less than waves of 30 micrometres. It does not follow, however, that there is not a strong chemical action from the blue-violet frequencies to which the glass is transparent.

Leduc<sup>1</sup> found that the light emitted from the negative brush of a Geissler tube exercises at a distance of several metres an intense photographic action upon one of the least sensitive of the bromid-of-silver papers, as, for example, the velox. Upon the latter an instantaneous impression is made at a distance of several centimetres. This fact the experimenter can easily prove by placing the source of the rays in front of a blackened chamber, the wall of which is pierced with a hole by a needle. In 30 seconds an image of the same, enlarged four times, can be obtained on a gelatino-bromid plate at a distance of 0.8 m. from the wall. In the same manner there may be obtained, with equal facility, negatives directly upon the paper. A bario-platino-cyanid screen may be substituted for the photographic surface, and a beautiful fluorescent image obtained.

A great deal of energy employed is transformed into the chemical activities, as the negative brush of a Geissler tube does not produce luminous or heat rays. There is no emission of the chemical rays from the positive terminal. In order to intercept the other rays Leduc enveloped the fluorescent part of the tube in black cardboard. A photograph of

---

<sup>1</sup>Revue Internationale d'Électrothérapie, Feb., 1902.

the entire tube showed that the middle part emitted many of the photographic rays. A photograph of the negative brush showed the emission of the chemical rays at that point. This phenomenon is analogous to that which has been studied with electric points in air at atmospheric pressure. The rays of the negative brush of the Geissler tube, identical with the violet rays of the spectrum are reflected, refracted and polarized; the beams can, therefore, be concentrated by lenses or mirrors or scattered by prisms.

On the strength of Leduc's observations, Colombo<sup>1</sup> very carefully investigated the therapeutic merits of Geissler tubes as a source of chemically active light energy. Of a series of cases treated, he reported in detail, three of lupus vulgaris treated by Geissler tube light. They had respectively 36, 65 and 76 exposures of from 15 to 20 minutes each daily, with absolutely no effect upon the lupus patches. The light energy of vacuum tube discharges is neither sufficiently complex nor intense to establish the tissue reaction necessary for the purpose of controlling lesions so deep seated and well organized. The same is true of all medical vacuum tubes. But it does not follow that they are valueless. They are of great value, and meet most satisfactorily the more recent congestions and inflammations. In conditions of circulatory stasis they act promptly. The brush discharge in vacuo may be used to an advantage in the early stages of inflammatory processes, incipient abscesses, for example; in sprains and contusions they also serve to relieve congestion due to the injury, and in that way favor prompt resolution.

The author has found them to serve an excellent purpose in the chronic catarrhal conditions so commonly found in all classes of cases. Intra-nasal applications three times a week for five minutes to each naris have relieved the congestions, lessened the thickening and discharge in hypertrophic cases, the scabbing and crusting in atrophic cases, establishing freer nasal respiration. Post-nasal dropping is

---

<sup>1</sup>Medical Electrology and Radiology, Oct., 1902.

also markedly modified, and the state of many of these patients very much improved, more so than by the classic measures. In a case of acute catarrhal cold supervening upon a chronic smoker's throat, and associated with severe asthmatic attacks, the asthmatic condition was so grave as to prevent dorsal decubitus. Sneezing was constant, nasal respiration impeded, mouth breathing, increased secretion, nasal and post nasal, enlarged and congested uvula, with strangling. The patient had not slept for several nights, and did not dare lie down because of the choking and asthmatic condition. A single intra-nasal application of the vacuum tube discharge, five minutes to each naris, also post-nasal application to the degree of toleration in time, followed by an application to skin surface of throat, especially over the region of the tonsils and uvula, resulted in so complete an amelioration of all the symptoms that the patient passed a comfortable night. Respiration, nasal and bronchial, was free, discharge was lessened, sneezing arrested, and asthmatic attacks controlled. This relief must be regarded as symptomatic only, but symptomatic relief under such circumstances is more than worth while. If successive applications are made over a period of time, nutritive changes will be established, which, in conjunction with appropriate hygiene, will do much to prevent the recurrence of similar conditions.

In the author's experience these vacuum tube discharges have rendered excellent service in the treatment of chronic catarrhal deafness, i.e., in modifying the degree of deafness. The accompanying tinnitus has also been relieved to a very considerable extent. The small aural electrode shown in Fig. 41 has been used for this purpose, its distal end being placed within the external canal and applications made for from 3 to 5 minutes each daily to every other day and less frequently in the latter part of the treatment. This has been supplemented by the use of a surface vacuum tube electrode, applied directly over the mastoid region for from 5 to 10 minutes each.

In the event of a chronically congested condition of the mucous membranes of the throat, an application is either made directly to them by means of a suitable tube, the one shown in Fig. 41 for tonsilar applications or with a surface electrode to the external surface over the tonsils and in the median line opposite the pharyngeal mucous membrane. For these purposes the author prefers the tubes with the leading-in wires because of the greater and more uniform distribution of the electrical discharge. Undoubtedly there is an action as well from the blue-violet frequencies of light.

At the same time that these vacuum tube discharges favorably modify chronic catarrhal conditions, the author has not found them of as great value as local applications, intra-nasal, tonsilar or aural, of the continuous current, negative—by means of suitable metallic contacts or with water as the electrolyte or by the use of oxidizable metals at the anode.

But for the more acute and recent processes the vacuum tube discharges are indicated primarily. In a case with a very considerable enlargement of the left parotid gland, following parotiditis, a single application by means of a surface vacuum tube electrode resulted in almost complete disappearance of the enlargement. This was unquestionably due to the establishment of circulatory drainage. The gland enlarged subsequently but to much less extent and was completely relieved. The many different uses to which these discharges can be put by suitably shaped contacts will suggest themselves to the individual practitioner.

## CHAPTER XVIII.

N Rays. Their Place in the Spectrum and Relation to the Living Organism. Blondlot and Charpentier.

### N Rays.

A discussion of light energy in its manifold phenomena in relation to life will not be complete without considering the living organism as an emissive as well as an absorptive agent. All bodies give out rays and it would be strange if the animal organism were an exception.

Some eighteen months since, there was discovered by the distinguished physicist, M. Blondlot, a new kind of light to which he gives the name of N rays, in honor of the University of Nancy, where the work was carried out.

These rays are not yet accepted by physicists as an undoubted scientific fact. Blondlot has found a probable explanation of the failure of many other physicists to repeat his observations. It lies in the fact that the emission of light is affected by N rays in the sense of being concentrated upon the normal rather than upon the tangent plane. Thus an observer watching the surface perpendicularly sees it brighten up; while if he watches it along the edge it appears to become duller. In the case of N rays the reverse is the case.<sup>1</sup>

There is, however, an accumulation of considerable data on the part of different experimenters which seems to point conclusively to the correctness of Blondlot's original observation.

Blondlot isolated these rays first from the Roentgen rays

---

<sup>1</sup>Comptes Rendus, February 29.

in the complex light emanating from a Crookes tube. Subsequently he demonstrated their existence in incandescent bodies such as the Auer mantle, the Nernst filament and even the solar rays. He has shown that every body in a state of molecular strain is a source of N rays and also in an almost indefinite fashion certain bodies in a state of constrained equilibrium, as tempered steel or glass for example; while the same is true of bodies which change their molecular equilibrium transiently, as a rod of bamboo when bent or a plate glass when being curved. The tempered blade of a Gallo-Roman knife emits them as well as modern steel. Because of these conditions as observed by M. Blondlot, he finds them comparable with the emission from uranium and radium.

N Rays Physiologically as well as Physically Important.—Blondlot also discovered that the N rays act upon the retina, increasing acuteness of vision. From the suggestions made to Blondlot by Charpentier (University of Nancy), whose experiments from the physiological side will be considered later on, he conceived the idea of trying if the compression of wood, of caoutchouc, and of glass would not provoke an emission of rays. At once he recognized that there was an emission during the time that the compression lasted. Similarly, upon bending a piece of wood the same phenomenon takes place and simultaneously the movement of the clock dial used for testing their presence can be more clearly seen.

This led to the further observation that the emission from tempered steel and tempered glass in a condition of constrained molecular equilibrium by reason of the process of tempering, was permanent. This emission appeared indefinite. The tools coming from the Merovingian epoch continued to emit the N rays at the level of the tempered parts.

Macé de Lépinay thinks that during musical vibration in such instruments as the tuning fork or siren, these rays are given out apart from the molecular strain. According to Jegou they are given out during the passage of a current in



an electric wire. Lambert has found that soluble ferments emit N rays, especially the ferments concerned in the digestion of albuminoid matter. Meyer has found that plants emit N rays whether they are kept in the dark or exposed to light, and that there is no difference due to the action of light.<sup>1</sup>

Meyer has discovered some new sources of the extinguishing rays called by Blondlot N rays, and has obtained rays of a higher penetrating power than heretofore. If a screen with patches of phosphorescent calcium sulphid is placed in the receiver of an air pump and the pump is worked, the phosphorescence decreases, being restored as soon as the pressure is restored. The same thing happens if the screen is placed outside instead of inside the receiver. An incandescent lamp through which no current passes or a vacuum tube, are powerful sources of N rays, the strain of the glass under the atmospheric pressure being sufficient to account for their production.<sup>2</sup>

Place of N Rays in the Spectrum.—At first the N rays were placed at the infra-red end of the spectrum below the heat and near to the electric waves; more recently evidence points to their belonging to the violet end, their mean wave length being something like one-tenth that of extreme violet light. Blondlot has observed that these rays are not all of one kind and has also distinguished N<sup>1</sup> rays. Assuming their existence, the N rays, wherever they belong, are of interest as showing that there are more rays yet to be discovered and gaps to be filled in.

Screens to Facilitate Observation of N Rays.—For this purpose there is placed between the eye and the source of N rays a screen of pure blue glass, which Blondlot obtained by superimposing two special glasses, both blue, but of different spectral composition.

According to Charpentier, the following method of observing the physiological radiations, i.e., from living animals

---

<sup>1</sup>Comptes Rendus, Feb. 29, 1904.

<sup>2</sup>Comptes Rendus, April 11, 1904.

and the human organism, is the most simple: Place upon a black card a layer of collodion for adhesive purposes and then cover it with a quantity of phosphorescent sulphid. The sulphid should be spread out so as to form a spot 2 cm. in breadth and enough used to give a thin layer. It should then be exposed to sunlight and observed in a place more or less dark, according to the light it presents. Several minutes are necessary for the eye to adapt itself to this relative obscurity. The card thus prepared must be regarded with an indirect vision and without too much attention, just as the phosphorescent gleam of a tube of radium must be observed when placed in a dark closet, for example. The variations of light are produced gradually, which depend above all, upon the thickness of the sulphid. To this end the latter should be placed as thinly as possible on the collodion treated black card.

Aluminum Arrests the Nervous Rays.—A plate of half a millimetre, Charpentier found sufficient to obscure in an appreciable fashion the N rays given off by a portion of the brain. Additional thicknesses of aluminum, even one or two cm., does not interfere with the penetration of such rays as pass the thinner aluminum screen. The N rays given off by the heart, the diaphragm or different muscles are not modified, or so slightly as to be of no importance by the aluminum plate.

Characteristics of N Rays.—In common with other forms of radiation N rays have varying degrees of penetrability. They are absorbed by some substances and transmitted by others. N rays are arrested in great part by lead, water and moistened paper. According to Bichat, N rays act differently when bodies are placed in their path, and he has shown a possibility of selective absorption by different metals. They pass easily through aluminum, black paper, wood and saline water. These rays are, in common with luminous rays, capable of being reflected; likewise they have the properties of refraction, interference and polarization. The index of refractions has been determined by means of aluminum

prisms. Blondlot observed that the index of quartz for these rays is about 2. He, therefore, compared them with the rays of Rubens, those remaining from filtration through rock salt, for which the index is 2.18. Charpentier states that he has obtained true foci, manifested by maxima of brightness, by converging lenses of glass. He found the index of refraction of rays given off by the body the same as observed by Blondlot for the rays given off by different substances. These rays can also be polarized. Blondlot observed that the N rays emitted by a Crookes tube, and filtered by a sheet of aluminum or a black paper presented rectilinear polarization. Their plane of polarization is deviable by a plate of quartz or a piece of sugar. A plate of mica set so that its axis made an angle of  $45^\circ$  with the plane of action of the rays destroyed the rectilinear polarization. This shows the double refraction.<sup>1</sup> Bagard has succeeded in reproducing the rotation of the plane of polarization in a magnetic field which was first produced by Faraday in the case of ordinary plane polarized light, and is usually shown as the Faraday effect. Since ordinary light consists of waves about 100 times as long as those which make up N rays, and since, according to Faraday, the rotation increases as the waves become smaller, it was natural to expect the Faraday effect to be very large in the latter. This has been fully verified by Bagard, who obtained rotations in aluminum and in carbon bisulphid, such as can with ordinary light only be obtained in quartz.

Blondlot has found that besides the kind of N rays already described, there exists another kind which reduces the luminosity of a feebly luminous surface instead of increasing it.<sup>2</sup> These are N<sup>1</sup> rays.

Gutton has found that the effect produced by N rays upon a luminescent screen may be imitated by means of a non-uniform magnetic field.<sup>3</sup>

---

<sup>1</sup>Comptes Rendus, Feb. 29, 1904.

<sup>2</sup>Comptes Rendus, Jan. 25, Feb. 1, 1904.

<sup>3</sup>Comptes Rendus, Feb. 29, 1904.

Some substances seem to have the power of accumulating or storing up N rays. Bodies placed in sunshine, Blondlot has observed, seem to possess the property of storing these rays. Charpentier raised the question as to whether the human body really emitted these rays or whether it only stored them during the day or in the light in the fashion of the bodies exposed to sunlight by Blondlot. After a night's rest of nine hours in the dark, the phenomena were presented in the same fashion, the observations even being more readily made because of the more perfect adaptation of the rested eye. They were observed not only near the skin but at a distance as well. The nearer, the greater intensity, however.

The luminescence of phosphorescent bodies is increased by the action of these rays.<sup>1</sup>

They are said to have the power to increase in length the electric spark, and Blondlot has described a photographic method of recording changes in the electrical phenomena and brightness of phosphorescence. Charpentier seems to think that they may be transmitted through a metal wire, and excite phosphorescence upon a suitable screen at the other end of it, but he considers that these are probably not ordinary N rays, and Bichat thinks that the conduction through a wire is much the same as that of light waves passed through a curved glass rod.

Effect upon the Retina.—The N rays seem to act upon the retina and visual acuteness is increased by them. When looking upon an object in semi-darkness it is possible to distinguish the details very vaguely, but if there is directed upon the globe of the eye a "sheaf" of N rays the object is more clearly seen. Blondlot in his experiments with a clock dial placed at 4 metres, which gave only the impression of a gray spot, observed that by directing to his eyes a source of N rays, the details of the dial, figures, etc., were clearly visible. Upon removing the source of N rays the dial again

---

<sup>1</sup>Comptes Rendus, Jan. 25, Feb. 1, 1904.

became but a gray spot. In connection with this observation, Charpentier observes that the result may appear surprising when it is remembered that water even of little depth arrests them. But as water with the addition of a little salt permits of their passage, he finds in the salinity of the fluids of the body a reason for their transmission. It was observed in this experiment that it mattered little that the incidence of the N rays differed much or little from that of the visual rays going from the eye to the object observed.

N Rays from the Human Body.—The observations and reports from Charpentier have increased medical interest in the physiology of the subject. He states that rays similar to the Blondlot rays are given out from the human body during muscular and nervous excitement. The rays thus produced increase phosphorescence, the length of the spark of a coil, the passage through certain solid bodies, and the reflection, refraction, and index of the latter seem to be the same as N rays. Absolute darkness, according to Charpentier, is essential for some observers, while others require relative darkness only, and the screen should be excited first in order to see if there is an increase of phosphorescence during the application of the N rays. Charpentier, in his observations upon living organisms, used screens of platino-cyanid of barium, regulating the luminous intensity by the aid of a salt of radium covered with a black paper, and placed at a variable distance. It is simpler, however, to use phosphorescent sulphid of calcium, moderately acted upon by the sun, as described under screens.

Augmentation of the Phosphorescent Light.—In order to clearly observe the increased luminosity of the phosphorescent screen a preliminary education of the eye is necessary. To this end a sufficient repose of the organ is advised. Complete darkness is not always necessary, that depends upon the luminescence of the object. This is governed by the power of the emitted rays. Charpentier states that the phosphorescent or fluorescent object increases in luminous intensity as it approaches the body, and that this augmen-

tation was greater in the vicinity of a muscle, increasing as the muscle was strongly contracted. The same was observed with a nerve or a nervous centre, the effect increasing with the function of the nerve.

Charpentier was able to follow in this way the course of a superficial nerve (a very delicate observation he states), as, for example, the median nerve, cubital nerve and various filaments near the skin.

Charpentier concluded from his observations that the human body emits N rays, and that the tissues whose functioning is most intense emit them in the greatest quantity. In this condition, he notes, is to be found a new method for the study of muscular and nervous activity. This he regards as important, especially so far as the external reactions of the nervous system are concerned, for at present the means of appreciating its effects are only secondarily by muscular contraction and sensation. He also finds in these conditions the base of a new method of clinical observation. The area of the heart, a muscular organ in almost continued activity, can by careful observation be determined by a small luminescent object carried around the cardiac region near the cutaneous surface. By the changes in its brightness the limit and the surface of the projection of this organ can be observed. It is suggested also that by the aid of the N rays the position of the muscles may be determined, the peristaltic movements of the stomach, liver and diaphragm, as well as the heart, as muscular activity is a feature of all these functioning organs. The possibility of studying the exterior outline of the nervous centres is also predicted by Charpentier.

Effects of N Rays upon the Cerebrum and upon Reaction of the Pupil.—Charpentier has discovered two new effects of N rays. If a strong source of N rays is placed 4 cm. behind the top of the skull and a little above it, not only are faintly luminous objects perceived with greater brightness and detail, but in absolute obscurity a faint luminous cloud is perceived. The other new effect is the enlargement of the

pupil when the condensing plate is placed over the seventh cervical vertebra.<sup>1</sup>

Emission of N Rays by the Lower Animals.—(1) The emission of rays by living organisms is not a phenomenon peculiar to man. It presents itself as well in the various animals usually found in laboratories, from which it may be concluded that it is a phenomenon characteristic of the lower animals. With these animals as with man it is the muscles and nerves which form the principal source of the radiation, and this is greater when they are in a state of functional activity. (2) As it was possible to maintain the frog at the time the experiments were made (December and January), at a temperature sensibly lower than that of the air of the laboratory, between 0° and 10°, for example, Charpentier found it possible to show that the increase of phosphorescence in his experiments was not due to rise of temperature. He found under the conditions indicated that the general laws of the phenomenon remained unmodified. Even when the phosphorescent object is first treated to a temperature higher than that of the body, 40°C. or a little less, thereby increasing its luminosity, it would still be observed in the neighborhood of muscles, nerves and nerve centres to increase in luminosity. This becomes still more intense if these organs are functioning. Charpentier observed that under the influence of the light of the electric spark, from both the primary and secondary of induction coils, i.e., ultra-violet light, these radiations were increased.

Distinction Between Nerve and Muscle Radiation.—To answer this question Charpentier made some observations on a curarized frog by which he established the fact that muscle radiates by itself, but less than the nerve. He observed that when the faradic excitation of the motor nerve or of its peripheric end is not efficacious in producing muscular contraction, still the emission of N rays was observed by the action upon the phosphorescent screen. Charpentier

---

<sup>1</sup>Comptes Rendus, Jan. 25 et Fév. 1, 1904.

regarded it as proof that in curarization, the terminal or peripheral filaments of the nerves can be placed in a state of excitation and that in the muscular emission of N rays the terminations of the nerve take part at the very last in the phenomena. In the second place the curarized muscle was directly excited. It contracts and gives out N rays. This does not seem to be more than the excitation of the peripheral nerve endings and Charpentier suggests that the emission of the N rays could very well in this instance be due to excitation of the intra-muscular filaments. The day following the experiments the frog was dead and his gastrocnemius was found inexcitable even by a strong faradic current. There was no appreciable augmentation near the muscle. On the contrary, the excitation of the peripheral end of the nerve although ineffective gave place to an increased phosphorescence against the muscle. From this the inference is drawn that in the emission of N ray by muscle, the excitation of nerve terminations intervenes for the most part, but that probably that of the muscular substance intervenes also and more feebly. This is not regarded as a certain conclusion. Of this fact, however, Charpentier was convinced that there was a proper radiation from muscle. The radiation between muscle and nerve was differentiated by the observation that the nerve increases its radiation notably under the influence of the lightest compression.

Charpentier with his colleague Professor E. Meyer made this observation upon the spinal column and nerve roots of a dog. Compression does not so markedly influence muscle radiations. By the radiations, Charpentier found it possible to distinguish the presence of nerves upon a part of the body and also to appreciate their contributory part in the total radiation coming from an organ. The nerve radiation produces stronger phosphorescence, compared with the radiation of other tissues, upon the phosphorescent sulphid when heated near  $40^{\circ}$  or  $45^{\circ}\text{C}$ .

From these observations as to the difference between the radiations of different tissues Charpentier concludes that the



nerve radiation differs more than that of any other part of the body from the pure Blondlot rays.

Relation to Temperature.—The rays are not due to an increase of temperature in the vicinity of the skin, for they persist even when many layers of aluminum or of cardboard, separated by layers of air, forming a calorific screen, are interposed. And again, they cannot be the result of heat, because of their immediate development, i.e., a few seconds, whereas the effect of heat taken much longer; moreover Charpentier is satisfied that similar rays are emitted from animals, such as the frog, which may be kept at a temperature from  $0^{\circ}$  to  $10^{\circ}$  below the air.

The Effect of N Rays upon Phosphorescent Bacteria.—The phosphorescence of bacteria is augmented by them. During the summer of 1903, Charpentier observed that the luminescence of the glow worm increased upon exposure to N radiations from the sun. He also observed that cultures of phosphorescent bacilli, photobacterium and phosphobacterium italicum responded in the same manner to the radiations from the heart, the muscles and the nerves as did the sulphid of calcium screen. Phosphorescence diminishes with bacilli when the temperature rises above  $25^{\circ}$  or  $30^{\circ}\text{C}$ ., and even less.

N Rays Given Out by Muscles in Contraction and Nerves under Compression.—They are not only given out by muscles in contraction, but compressions of nerves give the best results. Charpentier selects certain regions, such as the spinal cord over the cervical and lumbar regions, for special demonstrations. The entire tract of the spinal cord was found to increase the phosphorescence of the screen, opposite the nearest external part. For instance, opposite the cervical and lumbar enlargement the radiation is stronger and more extended. Upon contraction of the arm of the subject under observation, the brightness of the screen augments at the cervical enlargement. There is an increase in the brightness on passing up the cord to the neck. If the contraction of the arm is only unilateral the illumination is more marked on the

same side of the cervical region at first, while toward the upper part of the cord it goes to the opposite side, to the left, for example, if the right arm has been contracted. The localization of this increased luminosity to the left is a little variable, but is generally situated low down in the bulb.

For his experiments, Charpentier used straight tubes of lead 5 to 10 cm. long. One extremity is placed against the body; the other contains inside a little washer of cork or cardboard covered with phosphorescent sulphid. Glass tubes as well as tubes of metals have been used. The emitted rays in "pencils" as far as possible must follow the length of the tube. Large screens cannot be utilized because each part of the sulphid is influenced by the others, and the ensemble gives a light of uniform appearance in function with the total mass of the rays which meet the screen. Difficulties will be encountered in localizations deep in the body by reason of the different properties of the superimposed tissues.

Muscles in Contraction as a Source of N Rays.—As solids subjected to mechanical constraint emit N rays Charpentier sought for them in tendons during muscular contraction, a condition analogous to the strain in inanimate substances. His observations were made on the tendo Achillis and on the tendon of the extensor of the great toe as well as other tendons. There was no increase of the luminescence of the excited screen, no matter how powerful the contractions were. He observed, however, that the points of insertion and the osseous parts glowed under the influence of muscular activity. This he attributed to the fact that the tendons themselves were very poor in nerves while the preceding points are rich in terminal nerves whose compression would suffice to explain the phenomena of radiation. This radiation was arrested in this locality by aluminum as well as elsewhere.

The compression of a nerve, though light, increases the luminescence notably either above or below the point compressed. Prolonged compression causes the radiation gradually to diminish.

N Rays Emitted by the Brain During Activity.—Charpentier also observed that central convulsions, such as Broca's, show an augmentation of the luminosity while one is speaking. Other centres of brain are said to act similarly. This centre was precisely localized as by the surgeon for operative purposes. The subject of the experiment then spoke either loud or low, the excited screen being moved over the side of the cranial case. The luminosity increased on the left in the region near this centre, presenting a maximum which corresponds within the limits of 1 to 2 cm. to the point of the sulcus, known clinically. Nothing parallel is observed on the right side. A slight increase of brightness was observed opposite the convolution of Broca, arising from the centre opposite or from deeper centres interested in vocalization. In pointing the tube obliquely so as to aim only at the centre of Broca, the radiation becomes very feeble or is wanting. Similar radiations were observed during the functioning of other motor areas, each responding in its proper zone to the act of writing, movements of upper extremities, etc. Excitation of sensitive nerves gave rise to the same phenomena. The conclusion was therefore reached that every nervous centre when functioning increases its emission of radiation in repose, in proportion to the degree of activity. These rays are divergent as they are transmitted, following the law of optics, and they traverse with more or less refraction successive media.

N Rays in Relation to Mental Effort.—This was also made the subject of experiment, and it was found that mental effort on the part of others as well as upon the observer himself sensibly increases the luminosity of the excited screen. In this instance the excited screen is placed upon the forehead. A condition of mental relaxation is secured so far as possible in the one instance and one of earnest thought, involving a calculation or process of reasoning, in the other. The difference observed in the luminosity though feeble, is plain, being the more marked in the subjects appreciating best the real significance of mental inertia and activity. All

marked effort of will or attention increased the radiation to an extent visible to outside observers. Violent effort is not necessary, simply a clear fixation of the will or attention upon the single thought.

If the subject formulates a wish, for example, that the screen may become brilliant, or expresses indifference to the matter, he may himself observe the effect upon the screen, or as Charpentier naively remarks, "Can see himself think." Variations of intensity of reflection and attention give corresponding variations of luminosity in the excited screen as it is moved over the forehead. Familiar subjects do not produce the effect of new and complicated subjects. It will be of great importance in this connection, Charpentier suggests, to prove that the will and the suggested idea as well can influence feebly but truly a physical phenomenon.

The N Rays as a Chemical Reagent.—In the further investigation of N rays, experiments have been made to determine what possible reaction the N rays may have as chemical reagents. Colson<sup>1</sup> is of the opinion that the N rays are capable of being utilized as a delicate chemical reagent of considerable value. Some chemical reactions are the source of N rays, while other and very similar ones are not. In preparing zinc hydrate the result is the same whether zinc sulphate is added to caustic potash solution or the latter is added to the former. But in the latter case, the reaction gives rise to N rays, which diminish the brightness of a phosphorescent screen, whereas the reverse process does not give rise to the rays. This evolution of rays is accompanied by the formation of a basic salt which is only formed as long as the zinc sulphid is in large excess. Calorimetric tests show that the formation of this basic salt gives rise to a greater quantity of heat than the formation of the zinc hydrate without such an intermediary stage.

N Rays Complex in Their Nature.—Lastly, Charpentier declares that the rays are complex in their nature and that

---

<sup>1</sup>Comptes Rendus, April 11, 1904.

filtration through different metals will result in different effects. The physiological radiations are N rays for the most part, but their composition seems more complex than those described by M. Blondlot, from which they differ in certain respects. Lead does not arrest them completely nor does pure water.

Possible Diagnostic Value.—Granted that the intensity of these radiations is proportioned to the functional activity of the nerve or muscle whence they emanate, Charpentier believes that there proceeds from these proofs a new method of investigation applicable to physiology (muscular and nervous activity) and even to clinical study. Notably, one can, with some attention, map out the area of the heart, an organ in almost continual muscular activity; for a little luminescent object moved near the skin in the cardiac region manifests by its changes of brightness the limit and the surface of projection of the organ studied. It is stated that an Edinburgh neurologist considers it possible that obscure brain tumors may be located by means of these rays.

Digitalis and the N Rays.—It has recently been observed by Jean Becquerel, son of the distinguished physicist Henri Becquerel, that digitalis, when placed near the functioning heart, emitted N rays to a visible degree, but not when alone.

The truth of this statement must be vouched for by the fact that it was reported by Henri Becquerel<sup>1</sup> to the French Academy of Sciences. If true it would indicate that the physical agency of drugs has been the most potent after all, not the chemical. The physical is back of the chemical throughout the varied phenomena in nature. Bacteria are agitated by short and high frequency vibrations of light energy and in the resulting chemical change they yield up their life. The author is disposed to believe that the physical action of drugs is paramount; that the vibration of strychnia molecules for example finds a response in the vibrations of anterior ganglion cells and so stimulates them. Energy is trans-

---

<sup>1</sup>Comptes Rendus.

ferred by wave movement and nerve impulses, cerebral or peripheral, are waves. The laws of transformation and conservation of energy hold good for the living being. Stimulus received at the periphery is transmitted to the interior. The answer comes in excitation of the motor apparatus and is revealed in movement and nutritional processes. It is but rational that the animal organism, which has been likened to "one gigantic neuron," should be affected primarily by the varying rates of vibrational activity of various drugs, as it is by other vibratory influences.

The most recent literature that has come to the author's attention places these rays at the violet end of the spectrum rather than at the opposite end between the infra-red and the shortest wave length Hertzian ray. To the author's mind this would seem the rational place for such rays if they really exist. As has been shown in this analysis of the work of Blondlot, Charpentier and others, their most important characteristics are (1) high refrangibility, (2) great penetration, (3) luminescent excitation. They increase phosphorescence but do not initiate it. They can be reflected, refracted, polarized and brought to a definite focus like light rays but differ from them in their ability to penetrate aluminum, black paper and most substances transparent to Roentgen rays. They are not regarded in the least as ions, electrons, effluvia, auræ or other particular emanations.

Remarks Based upon their Supposed Position at the Lower End of the Spectrum.—If N rays exist, still doubted by many able physicists, they will help to bridge over the gulf between electrical action and radiant energy. Their study will, it is said, be a revelation in the general theory of radiation, and their unusual properties serve to broaden the current conceptions of transparency and opacity as well as the view of the interrelations between radiant energy and electrical action. Blondlot's discovery is regarded as of peculiar value in the fact that it deals with things which have a direct and comprehensible and even unclassified relation to the general theory of radiant energy.

There is a belief on the part of some that they are complementary to the "dark rays" which Gustave de Bon discovered proceeding from the unilluminated surface of thin opaque metallic plates exposed to the action of ordinary light. If this be true it would appear that certain ethereal vibrations beyond the two ends of the visible spectrum exhibit similar powers of penetration, those at the ultra-violet end being in addition photo-chemically active.

In their relation to organic substances, and especially the human organism, these rays, if they really exist, as so convincingly set forth by Charpentier in his experimental observations, open up a wonderful field for research, which, if fully covered, will doubtless illumine many hitherto not understood and curious phenomena.

"The degree to which the phenomena are manifested is co-relative to the character of the idio-muscular contractions, being proportionate to their rapidity and energy. The same is to a less extent noticeable in inanimate bodies, in which the processes of natural resolution into simpler compounds are retarded by artificial means. These discoveries afford a rational explanation of the 'Corpse Lights' said to have been noticed on opening up ancient graves, and of 'Od' force so widely discussed in the early Eighties."<sup>1</sup> These observations of Blondlot have been substantiated by Walsham and Leslie Miller of London. They state that they have been able to pass the rays through books and to discriminate between the results obtained when the muscle is in action and when it rests by the physical results or changes produced in the photographic plate. On the other hand, Schenk, Burke, McKenrick, and Campbell Swinton, have not been able to confirm the observations of Charpentier. That there is a truth in Charpentier's observations the author is prepared to believe. The reported increase of fluorescence upon the excited screen, as the result of mental effort, finds its counterpart in the movement of the light beam of the mirror galvanometer when placed in circuit with the subject.

<sup>1</sup>Editorial, *Med. Electrology and Radiology*, March, 1904.

Under date of August 26, 1904, comes the report that the Paris Academy of Sciences has awarded the Lecomte prize of 50,000 francs to Blondlot for his brilliant researches into this subject. As the opinion of this body carries considerable weight, there is less reason for questioning Blondlot's discovery or the existence of N rays.



## CHAPTER XIX.

Alpha, Beta and Gamma Rays of Radio-Active Substances. Uranium, Thorium, Polonium, Actinium and Radium. Radium: Its Physics, Physiological Action and Therapeutic Value. Prof. and Mme. Curie.

### Radium.

Perhaps of all the various manifestations of the energy of oscillating light corpuscles, the greatest mystery is the source of the ceaseless energy which is emitted by radium, the highest form of etheric vibration.

“The answer will probably be found in those vibrations of ultimate matter which are transmitted throughout space, which, as Duncan has said, is all ‘a-quiver with the waves of radiant energy,’ ranging from the infinitely short to the incomprehensibly long; the rays which most interest us being the exceedingly short while the waves of great length corresponding to the sound waves of the organ diapason are the waves of Hertz and Marconi, equally mysterious, but concerning us less at this time and place.”

The electro-therapeutist with his high frequency discharges from vacuum tubes, his ultra-violet rays, his cathode and X ray must of necessity have not only a scientific but a practical interest as well in radio-activity.

Radium, polonium, uranium, actinium and thorium form a group of radio-active metals which have been extensively experimented with and studied by Professors Becquerel, Thomson, Rutherford, Brookes, Lodge, Laborde, Ramsay and Professor and Madame Curie.

With radium, polonium, actinium and thorium, light is given off the moment they are created, without having to be stimulated by any source of heat, light, electricity or any other form of energy so far as is at present known.

A vast amount of speculation and some interesting hypotheses have been evolved to explain the phenomena observed in experimenting with these substances. Much has been learned from them "about the constitution of matter and the correlation of the vital and physical forces, more in all probability than any substances which have been created since the world began."

Becquerel Rays.—Following upon the investigations into the phenomena produced on the interior and exterior of various kinds of vacuum tubes to which great importance must be attached, i.e., the Roentgen rays, and also the photographic effects produced by phosphorescent and fluorescent substances, came the discovery in 1896 of M. Henri Becquerel of the radiations emanating from uranium, and which are known as Becquerel rays. The importance of Becquerel's discovery of radio-activity can hardly be over-estimated.

The question arose as to whether, if the emission of Roentgen rays did not necessarily accompany the production of fluorescence, what was the cause of the latter.

M. Henri Poincaré<sup>1</sup> was the first to attempt an elucidation of this problem. Following his announcement that he had obtained photographic impressions through black paper by the aid of phosphorescent sulphid of zinc,<sup>2</sup> was the statement of M. Niewenglowski<sup>3</sup> that he had obtained the same phenomenon with sulphid of calcium exposed to light. Strong photographic impressions with phosphorescent artificial hexagonal blend acting through black paper and a thick cardboard were finally obtained by M. Troost.<sup>4</sup>

<sup>1</sup>Rev. Gen. des Sc. 30, Jan., 1896.

<sup>2</sup>C. R. t. CXXII., p. 312.

<sup>3</sup>C. R. t. CXXII., p. 386.

<sup>4</sup>Ibid., p. 564—all quoted by Mme. Curie.

M. Becquerel followed with his studies upon uranium. He obtained photographic impressions through black paper with the double salt of uranyl and potassium. The first thought entertained was that the phenomena were due to fluorescence, but this was soon refuted. It was not necessary that the salt should glow to produce photographic impressions. In the author's experience, for example, a specimen of German radium, estimated to have a radio-activity of 40,000 which had a most brilliant phosphorescent glow, far in excess of that of a specimen of French radium having a radio-activity of 7,000, gave an absolutely negative result photographically for a 45-minute exposure, while with the latter, a 20 and 30-minute exposure gave a fair imprint. All the compounds of uranium, whether fluorescent or not, act the same and the most active of all is metallic uranium. Becquerel proved that these rays traversed thin metallic screens, discharged electrified bodies, and could be reflected, refracted and polarized. Becquerel's observations were confirmed and further investigated by Elster and Geitel, Lord Kelvin, Schmidt, Rutherford, Beattie and Smoluchowsky in every particular save in so far as the reflection, refraction and polarization of uranic rays were concerned. From this point of view they comport themselves as do Roentgen rays, as was first recognized by Rutherford, and subsequently by Becquerel himself.

Properties of Becquerel Rays.—These rays (1) impress photographic plates, (2) traverse liquids and solids if not too thick, (3) in traversing gases they render them feeble conductors of electricity. These properties are not due to any known exciting cause. The radiation seems spontaneous. When kept in the dark for years it does not diminish in intensity, as it is not a phosphorescence induced by light. Madame Curie measured the intensity of the radiation of uranium by utilizing the action of the radiation upon the conductivity of the air. Within the limits of precision of the experiment she has obtained numbers which prove the constancy of the radiation, i.e., to 2 for 100, or nearly 3 for

100. Becquerel rays are emitted by uranium and thorium. They differ from  $\bar{X}$  rays in their penetrating power, in that the greater part of the radiation is arrested by a few mm. of solid matter, and cannot leap into the air for more than a few cm. Rutherford,<sup>1</sup> especially, but other physicists also have shown that they are not capable of reflection, refraction, nor polarization. The laws governing the conductivity of Becquerel rays through gases is the same as for Roentgen rays. The theory of the ionization of the gases by the effect of Roentgen rays, and Becquerel rays sufficiently explains the observed facts. This theory leads to the following results: (1) The number of ions produced per second in the gas is considered as proportional to the energy of the radiation absorbed by the gas. (2) To obtain the current limit relative to a given radiation, it is necessary, on the one hand, to cause this radiation to be absorbed wholly by the gas, employing a sufficient absorbent mass. On the other hand, it is necessary to utilize for the production of the current all the ions created, in establishing a strong, electrical field, for the number of ions which recombine becomes an insignificant fraction of the total number of ions produced in the same time, almost all of which are taken by the current and drawn to the electrodes.

According to Madame Curie, the radiations from thorium are more penetrating than those of uranium, and those from a thick layer of oxid of thorium are more penetrating than those from a thin layer. A practical point to be considered in using oxid of thorium for therapeutic purposes is the thickness of the layer.

Radio-Activity of Uranium and Thorium an Atomic Property.—From a study of a considerable number of compounds, Madame Curie has found that the property of radio-activity is dependent upon the presence of the atoms of the two elements considered. It can neither be destroyed by a change of physical state nor by chemical transformation.

---

<sup>1</sup>Phil. Mag., Jan., 1899.

Of all the substances examined in her search for radio-active substances, Madame Curie found that uranium and thorium bear the largest atomic weight, 240 and 232. These two substances are met frequently in the same minerals.<sup>1</sup>

In 1898, Professor Pierre Curie and Madame Sklodowska Curie, when investigating the radiations from uranium discovered by Becquerel, found that some samples of pitchblende or uranite, from which uranium is extracted, gave forth radiations much more powerful than any uranium they had found, having four times the activity of metallic uranium.

Painstaking research resulted in the discovery of a substance associated with bismuth, and resembling it very much in its chemical characteristics. To this substance Madame Curie gave the name of Polonium, in honor of Poland, the land of her nativity.

Polonium is to be had in the form of a metal and in the form of a sub-nitrate. The metallic polonium resembles particles of nickel and the sub-nitrate is a white powder.

In the year 1898, Professor and Madame Curie, in collaboration with M. Bemont, isolated a second substance from pitchblende, which was associated with barium and possessed many chemical and other characteristics of that substance. To this they gave the name of Radium. In 1899 Debierne discovered actinium. Gietel finds that polonium has both deviable and non-deviable rays and Elster states that when it is placed in a vacuum it is found to be deviable by a magnet to a much greater extent than radium. The rays from actinium are also deviable, while the rays from radium are reflected from a straight line, differing in that respect from the Roentgen or X ray.

The Radio-Activity of Uranium Used as a Standard of Comparison.—The radio-activity of uranium is taken as a standard of comparison and polonium of 300 radio-activity or radium of 7000 radio-activity, means that the one is 300 and the other 7000 times more powerful than the original

---

<sup>1</sup>Madame Curie, *Recherches sur les Substances Radio-active.*

radiations emanating from uranium or Becquerel rays, Radium, actinium and polonium have a million times the activity of uranium according to Professor Curie.

Radium a New Metal.—Professor Curie regards radium as distinctly a new metal; it has never been found, however, in a metallic form, but is to be had as a chlorid or bromid.

Sources of Radium.—Since the discovery of radium, its presence in various parts of the world has been exploited but not always with true regard for the actual facts. The chief source of pitchblende, from which radium is extracted, has thus far been the mines of Bohemia.

A Mine of Radium.—Sir William Ramsay affirmed before a learned society of London, that there existed in the very heart of that great city, of which the soil has been so often turned over and thrown open, a mine of radium of great richness. For a number of years there has existed (since the use of uranium has increased) a manufactory of this rare metal in London. All the residue coming from its extraction has been accumulated not far from the factory which is still in action, as a *caput mortuum*, the disposition of which is difficult. If it should be proven that the waste contains radium, as do other uranium minerals, it would be an exceedingly convenient and valuable source of this precious substance. It is some months since Sir William Ramsay made this statement, but the author is not advised as to the correctness of his prediction.

The discovery of extensive uranium mines in Utah by Mr. Lockwood is referred to by Madame Curie in her work on radio-active substances. She notes that there has been formed at Buffalo a society entitled "Welhs-Laftus Uranium and Rare Metal Co.," which proposes to treat daily two tons of mineral which will permit the obtaining of 100 pounds of oxid of uranium, 10,000 grains of a radium-barium substance, having an activity of 10 units, and 100 pounds of the other metallic residues, consisting principally of polonium. Whether the output of this mine equals the expectation indicated above is not known.

Quantity of Radium.—This is true, that there is but a very small quantity of radium salts to be had. A year since it was estimated by Professor Curie that the three years' work done both in Germany and in France had, a few months prior to that date, resulted in the production of but one pound of radium, including all grades and qualities. All radium of higher radio-activity than 7,000 was until within a year retained for the experiments of Professor and Madame Curie and their associates, in the laboratory.

Radium salts can now be obtained for experimental and therapeutic work from a number of importers of chemicals and electro-medical apparatus. The price doubled within a space of a few months in the beginning of the present year. It is difficult to obtain in any, save minute quantities, but it is possible to secure radium salts of higher radio-activity than one year since. It is not possible to depend always upon the degree of radio-activity as demonstrated in the instance referred to by the author, where a salt of 40,000 radio-activity, brilliantly phosphorescent, was exceeded in photographic activity by 7,000 radio-activity.

The Process of Extraction of Radium.—Radium is a substance which accompanies the barium extracted from pitchblende. In its reactions it follows barium and it is separated from it by the difference of solubility of its chlorids in water, alcohol water or water and chlorhydric acid. Polonium, actinium, and radium are found in absolutely infinitesimal quantities in pitchblende. In order to obtain them in a concentrated state, the Curies found it necessary to treat many tons of uranium residue.

In the process of extraction of radium, the gross extraction is done in a factory, then purification and concentration follows. From thousands of kilograms of matter there are thus extracted, first a few decigrams of extremely radio-active products in comparison with the original mineral. Radium is the only one among the new radio-active substances which has been isolated as a pure salt.

Atomic Weight of Radium.—This was obtained in the

classical manner by Madame Curie and found to be 225 and is the largest atomic weight of any known substance. The molecule is therefore very large.

The Spectrum of Radium.—This was determined by M. Demarçay. The first specimen of radio-active chlorid of barium examined by Demarçay showed him not only barium lines, but a new line of notable intensity and of wave length  $\lambda$  381.47  $\mu\mu$  in the ultra-violet of the spectrum. Subsequently, with more active products it was noted that the 381  $\mu\mu$  was stronger and at the same time other new lines were observed. The new lines and the lines of barium were of comparable intensity. A new and more concentrated product showed the new spectrum predominating; the three strong lines of barium alone visible indicated the presence of that metal in a state of impurity. This product was regarded as a nearly pure chlorid of radium, but a more complete purification of it showed the two dominant barium lines but feebly.

The portion of the spectrum between 500  $\mu\mu$  and 350  $\mu\mu$  contains the principal radium lines. The intensity of each line is indicated by a number, the strongest being marked 16.

$\lambda$	Intensity.	$\lambda$	Intensity.
482.63.....	10	453.35.....	9
472.69.....	5	443.61.....	8
469.98.....	3	434.06.....	12
469.21.....	7	381.47.....	16
468.30.....	14	364.96.....	12
464.19.....	4		

All the lines are clear and straight, the lines 381.47, 468.30, and 434.06 are strong; they attain equality with the most intense lines actually known.

Two strong nebulous bands are also observed in the spectrum. The first of these is symmetrical, and extends from 463.10 to 462.19 with a maximum at 462.75. The second, which is stronger, becomes fainter toward the ultra-violet. It begins abruptly at  $\lambda$  446.37, passes by maximum to  $\lambda$  445.52. The region of the maximum extends even to 445.34; there is then a nebulous band gradually fading away



to 439. In the least refrangible part (not photographed) of the spark spectrum, the only line notable is the line about 565.5, very much more feeble than 482.63. The spectrum of radium is shown in the colored frontispiece. The general aspect of the spectrum is that of the alkaline earth metals, the spectra of which have strong lines with nebulous bands.

Demarçay finds that radium is one of the bodies having the most sensitive spectrum reaction.

In the first specimen examined which showed clearly 381.47, Madame Curie regarded the proportion of radium as very small, possibly 0.02 for 100. Notwithstanding this observation it is necessary to have an activity 50 times greater than that of metallic uranium to perceive clearly the principal line in the photographic spectra.

Radio-Activity More Sensitive than Spectrum Reaction.—The radio-activity of a product, when it is but 1/100 of that of metallic uranium, can be told with a sensitive electrometer. Radio-activity is therefore a thousand times more sensitive than the spectrum-reaction. Bismuth with polonium and thorium with actinium examined by Demarçay have given respectively only the lines of bismuth and of thorium. Giesel<sup>1</sup> finds that a preparation of the bromid of radium gives rise to a carmine coloration of flame. The spectrum of the flame of radium shows two beautiful red bands, one line in the blue-green and two feeble lines in the violet.

Characteristics of Radium Salts, Chlorid, *Asotate*, Carbonate and Sulphate.<sup>2</sup>—These salts of radium have the aspect of barium when fresh but all color with time. They are luminous in the dark. By their chemical properties they are absolutely analogous to the salts of barium. The salts of radium disengage heat spontaneously and continuously. The chlorid of radium is para-magnetic.

M. Curie and C. Chéneveau devised an apparatus by means of which they have measured the coefficient of

<sup>1</sup>Giesel, Phys. Zeitschrift, 15 September, 1902.

<sup>2</sup>Madame Curie.

chlorid of radium. This coefficient has been measured by comparison with that of water, and corrected for the magnetism of the air.

Radio-active chlorid of barium containing about 17 to 100 of chlorid of barium, is diamagnetic and possesses a specific coefficient.

Energy of Radiation (1) Photographically.—The energy of radiation of radium is considerably greater than that of uranium and thorium. With radium a photographic plate is acted upon instantly while an exposure of twenty-four hours is necessary for uranium and thorium.

(2) Fluorescence.—Radium on contact quickly illuminates a fluorescent screen. This is not true of uranium and thorium.

(3) Ionization.—Radium exerts a much greater ionizing action upon the air than uranium and thorium.

The total intensity of the radiation of radium is estimated by means of an electrometer but with more difficulty than that of uranium. With uranium the radiation is very nearly absorbed in the layer of air which separates the plates. It is not the same with more strongly radio-active substances. The radiation of radium is in part constituted of the very penetrating rays which traverse the condenser and metallic plates, and are not used to ionize the air between the plates. Nor, says Madame Curie, can the current limit always be obtained at the tensions, i.e., pressure, at one's disposal. For very active polonium, the current is still proportional to the tension, between 100 and 500 volts. The experimental conditions are such that there is not given to the measure a simple significance and in consequence the measures obtained cannot be considered as giving the measure of total radiation, and from this point of view they constitute only a gross approximation.

The following table from J. J. Thomson's work on "Conductivity of Electricity through Gases" shows the relative ionizing power of Roentgen, cathode, radium, polonium and uranium rays:

## RELATIVE IONIZATIONS.

Gas.	Relative Density.	Roentgen Rays.		Cathode Rays.	Radium Rays.		Polonium Rays.		Uranium Rays.
		Thomson.	Perrin.		Penetrable Type.	Absorbable Type.	I.	II.	
Hydrogen. ....	.0693	.33	.026	.069	.157	.218	.226	.219	.213
Air . . . . .	1.00	1.00	1.00	1.00	1.00	1.00	1.00	1.00	1.00
Oxygen . . . . .	1.11	—	—	1.106	1.21	—	1.16	—	—
Hydrochloric acid. . . . .	1.27	8.9	8.	—	1.46?	—	—	—	—
Carbonic acid. . . . .	1.53	1.4	1.34	1.53	1.57	—	1.54	—	—
Cyanogen. . . . .	1.86	1.05	—	—	1.86	—	1.94	—	—
Sulphur dioxide . . . . .	2.19	6.4	6.	—	2.32	1.92	2.04	2.03	2.08
Chloroform. . . . .	4.32	—	—	—	4.89	—	4.44	—	—
Methyl iodid. . . . .	5.05	—	—	—	5.18	3.74	3.51	3.47	3.55
Carbon tetrachlorid. . . . .	5.31	—	—	—	5.83	—	5.34	—	—

The following simple apparatus devised by Strutt<sup>1</sup> exhibits in a striking manner the dissipation of negative electricity from radium by the cathode rays evolved by it, and the accumulation of a positive charge. A glass tube, *a*, with thin walls, is hermetically sealed, and contains the radium preparation, as shown in the accompanying cut. It is suspended from above by the quartz rod, *b*, while from its lower end hang a pair of gold or aluminum rods, *c c*. The glass tube *a* is smeared over with a conducting coating of phosphoric acid, and the whole system hangs from the stopper, *d*, of the glass bulb, *f*. Strips of tin foil, *e e*, at the sides of the bulb are connected to earth. As long as there is air in the bulb no divergence of the leaves is observed, since the radium rays make this air a conductor. But if a good vacuum be made in the vessel, the leaves soon begin to diverge, owing to the loss of negative electricity by the radium. This divergence increases until the leaves touch the tin-foil strips. When this happens the leaves are discharged and collapse, and the cycle recommences. With a weak radium preparation, Strutt obtained a full divergence in about 20 hours. But with a more active preparation the cycle can be com-

<sup>1</sup>Elec. World and Engineer, April 9, 1904.

pleted in course of a lecture. The time in which the cycle is completed is, of course, an indication of the degree of radioactivity of the substance in *a*.

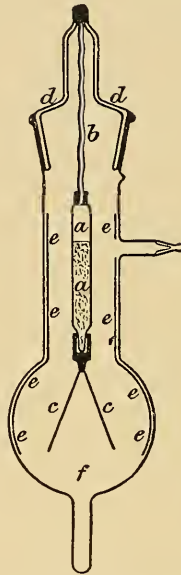

Fig. 43.—Apparatus for Demonstrating the Absorption of the Radium Radiations. Strutt.

A Modification of Strutt's Apparatus Demonstrating the Negative Charge of the  $\beta$  Radiations.—Paschen,<sup>1</sup> in an illustrated note, shows that the apparatus of Strutt for demonstrating the positive charge of radium enclosed in a glass tube, may be modified so as to demonstrate also the negative charge of the  $\beta$  radiation which penetrates the glass. As shown in the illustration, a glass bottle which may be evacuated contains the small glass tube *b*, which contains a radium-barium preparation, and is suspended by means of the quartz rod, *a*. Two quartz tubes, *a*<sub>1</sub> and *a*<sub>2</sub>, hold the hollow lead vessel *c*, of a thickness of 2 mm., which is com-

<sup>1</sup>Phys. Zeit., March 15, and Elec. World and Eng., April 9, 1904.

pletely insulated from *b*. Through *b* passes in spiral form the platinum wire, *f*, which is connected to the electroscope, *d*. The second electroscope, *e*, is fixed to the lead cylinder. As soon as a good vacuum is reached, both electroscopes diverge, *d*, with positive electricity, *e*, with negative electricity. It is also possible to demonstrate the current which flows from the interior of the glass tube to the lead cylinder,

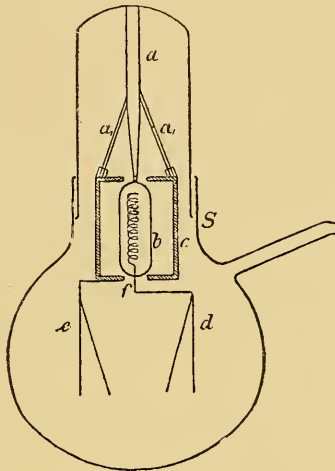

Fig. 44.—Paschen's Modification of Strutt's Apparatus.

if both are connected by a wire. This current was first measured by Wein. The divergence of *e* is always smaller than that of *d*, especially on account of imperfect absorption of the  $\beta$  radiation in lead of 2 mm. thickness. Within an hour the electroscopes converge and the charges of their conductors are neutralized, but the neutralization is not complete, both electroscopes showing afterwards a small positive charge.

Radium Radiation Complex.—The radiation of radioactive substances is a very complex one. There are three distinct types of rays distinguished. These are called by Rutherford the  $\alpha$ ,  $\beta$ , and  $\gamma$  rays.

In the first instance it was pointed out by Rutherford, that uranium possessed two distinct types of rays,  $\alpha$  and  $\beta$ , the former easily absorbed even by gases, while the latter are very penetrating, and but little absorbed by gas.

(1)  $\alpha$  Radiation.—The  $\alpha$  rays constituting the greater part of the radiation are slightly penetrating. They are most active in ionization of gas, as has been observed under experimental conditions. They are readily absorbed and a thin screen of metal suffices to cut off the most of them.

The magnetic field acts very feebly upon these rays. At first they were regarded as non-deviable. In a strong magnetic field there is a slight deviation which is produced in the same manner as in the case of the cathode rays; but the direction of the deviation is reversed, and is the same as for the canalstrahlen of a Crookes tube. This shows their identity with the positively electrified particle or atoms. Their mass is enormous in comparison with the  $\beta$  group. Rutherford deflected as much as 45 per cent. of them in a strong electrical field. He estimates that the energy of  $\alpha$  rays is a thousand times greater than that of the  $\beta$  rays, and they have very much less penetrating power. According to Rutherford all radio-active substances, including polonium, as well as excitable bodies and their emanations give out  $\alpha$  rays. It has been observed by Rutherford<sup>1</sup> that the absorption of the  $\alpha$  type of radiation emitted by uranium or any of its compounds was such that the intensity was reduced to one-half its value after passing through,

3 mm. of carbonic acid gas,  
4.3 mm. of air,  
7.5 mm. of coal gas,  
16.3 mm. of hydrogen.

The penetrating power of the  $\alpha$  radiation is intermediate between that of ordinary primary and secondary Roentgen

---

<sup>1</sup>Thomson: Conductivity of Electricity through Gases.

rays. The absorption of the  $\alpha$  rays was shown by Rutherford to be proportional to the density of the gas.

(2)  $\beta$  Radiation.—The  $\beta$  rays are much longer, have greater penetrative power, are readily deflected by a magnet in the same manner, and in the same direction as the cathode rays, and they correspond in every particular to the cathode rays, which, as is now generally known, are identified with the free electrons projected into space and proceeding from tangible matter. In other words, these electrons, atoms of electricity, are not undulations of the ether, nor a form of energy, but substances possessing inertia, undoubtedly electric. The  $\beta$  radiation has a velocity approximating that of light, and the  $\beta$  rays are projected from the cathode at a speed approximating 70,000 miles per second. The flight of some of them is retarded by collisions. By them electrified bodies are discharged through ionization of the air; but their ionizing power is feeble compared with that of the  $\alpha$  radiation. They have the power of impressing photographic plates, in fact they possess the properties of the cathode rays.

(3)  $\gamma$  Radiation.—The  $\gamma$  rays are the rays possessing the greatest penetrative effect, and they will excite or produce radio-activity at a distance of three feet or more. Rutherford's experiments show the relative penetration of the three classes of rays through aluminum sheets of varying thicknesses before there is a loss of half the intensity, which is formulated as follows:

- $\alpha$  rays through a thickness of aluminum .0005 cm.
- $\beta$  rays through a thickness of aluminum .05 cm.
- $\gamma$  rays through a thickness of aluminum .8 cm.

They are unaffected by the magnetic field and are comparable to the Roentgen rays; that is, they are vibrations of the ether, produced by the sudden arrest of the cathode stream coming into contact with the solid matter just as in a Crookes tube.

The accompanying classic cut shows the relative direction and extent of the three radium radiations,  $\alpha$ ,  $\beta$  and  $\gamma$ .

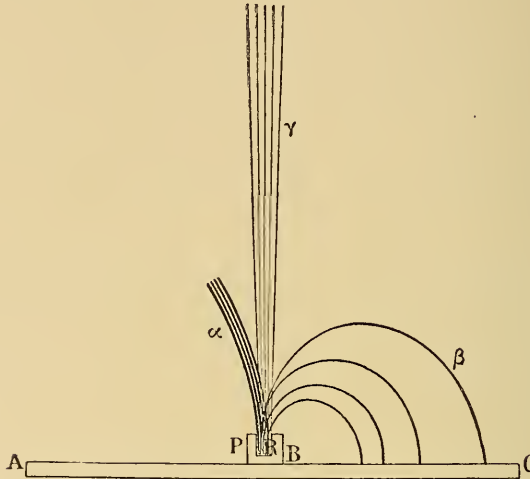

Fig. 45.—The  $\beta$  rays being negatively charged are bent strongly to the right. The  $\gamma$  rays ethereal pulses as are the X rays are not bent at all, and the  $\alpha$  rays being positively charged but massive, are bent but very little to the left, less even than appears. It is estimated that if the diameter of the circle of bending formed by the  $\beta$  ray is a quarter of an inch that of the  $\alpha$  ray circle of bending is eleven yards.

Let the radium,  $R$ , be placed at the bottom of a little cavity sunk in a block of lead  $P$ . A bundle of rays will escape from the cavity containing the radium. These are rectilinear and slightly expanding. If there be established in the region surrounding the hollow a uniform magnetic field the slightly intense gamma rays continue their rectilinear projection without trace of deviation. The Beta rays are deviated in the same manner as cathode rays, and as shown in the figure, describe some circular trajectories whose ray varies in extended limits. If the receptacle be placed upon a photographic plate,  $A, C$ ., the proportion  $B, C$ . of the plate upon which the energy of the  $\beta$  radiations falls receives an impression. Finally, the  $\alpha$  rays form a very intense bundle, which is slightly deviated, and which is very rapidly ab-



sorbed by the air. These rays describe a trajectory, the curvature of whose ray is very large, the direction of the radiation being the reverse of that of the  $\beta$  rays. If the receptacle should be covered with a thin screen of aluminum, the  $\alpha$  rays will be in a great part suppressed or arrested, the  $\beta$  rays less, while the  $\gamma$  rays do not seem to be noticeably absorbed. They go straight on as does the X ray.

Action of the Magnetic Field.—There are then two groups of rays very distinct the one from the other, of which one is easily deviated by the magnetic field, the  $\beta$  rays, while the other is apparently insensible to its action, the  $\alpha$  rays and  $\gamma$  rays, known as the non-deviable rays. Despite this classification, which is classical, it will be recalled that Rutherford deflected slightly with a strong magnetic field the  $\alpha$  rays or positive electrically charged atoms. The measurements of the magnetic field made electrically are confirmed by radiographic experiments. A very clear trace of the bundles separated by the action of the field is obtained upon a photographic plate placed parallel to the primitive bundle and normal to the field. Becquerel has shown that the impression constitutes a large diffuse band, a true continuous spectrum, and that the bundle of deviable rays emitted by the source is constituted of an infinity of radiations unequally deviable. The deviable rays  $\beta$  are charged with negative electricity, like the cathodal rays, and comport themselves as do the negatively charged corpuscles shot off from the cathode in a Crookes tube. It is a very feeble charge. Radium is the first example of a body spontaneously charged with electricity.

The velocity of the  $\beta$  rays of radium is greater than that of the cathode rays. Kaufmann<sup>1</sup> observed that this velocity closely approximated that of light, hence their great penetrating power.

Action of the Magnetic Field upon the  $\alpha$  Rays.—Rutherford<sup>2</sup> has shown that in a magnetic field the  $\alpha$  rays are

---

<sup>1</sup>Nachrichten d. k. Gesell. d. Wiss. zu Goettingen, 1901, Heft 2.

<sup>2</sup>Physik. Zeitschrift, 15 Jan., 1903.

slightly deviated and in the same fashion as the positively electrified particles or atoms as in the canalstrahlen of a Crookes tube. This accounts at least in a part for the law of absorption of radiation. If the charge of each projectile is the same as that of an atom of hydrogen in electrolysis, the conclusion is logical that the mass of this projectile is of the same order of magnitude as that of an atom of hydrogen in electrolysis. The projectiles which constitute the  $\beta$  rays are not only much smaller,  $1/800$  of an atom of hydrogen, but have a greater velocity than the  $\alpha$  rays. The inference is drawn from these reasons, that they have a greater penetrating power which is the case.

The Influence of Air upon the  $\beta$  Rays.—The air, which the  $\beta$  rays traverse, produces an acute diffusion for the strongly deviable rays. This diffusion is, however, of much less importance than that which is due to equal thicknesses of solid matter traversed. For this reason the deviable  $\beta$  rays pass into the air at great distances.

Spinthariscopes of Crookes.—It is the  $\alpha$  rays which are active in the very beautiful experiment of Crookes.

A grain of radium is held at the extremity of a metallic thread before a screen of phosphorescent sulphid of zinc and from 0 mm. to .5 mm., for example, from the screen. When viewed by the means of a magnifying glass with the face of the screen turned toward the radiation, there is seen a very rain of luminous points. They are due to the  $\alpha$  rays and the surface of the screen is literally bombarded by the positive atoms projected from the radium. The luminous points upon the phosphorescent surface are provoked by the shocks of isolated projectiles, and these scintillating phosphorescent patches are constantly changing their places due to the varying impingement of the positively electrified  $\alpha$  rays. The aspect of the luminous points is the same as that of stars or of ultra-microscopic objects which do not produce upon the retina clear images, but spots of light. This is in full accord with the conception that each extremely small luminous point is produced by the shock of a single atom.

This Spinthariscopic phenomenon observed by Crookes, was studied by Becquerel<sup>1</sup> in order to determine to what kind of radium rays it is due, and what physical process the scintillations represent. For the screens he used the hexagonal zinc blend or diamond dust. In a strong magnetic field the rays producing the scintillations were not deflected. This confirms Crookes' supposition that the rays producing the sparks consist of positive electrons. As regards the nature of the scintillations, they are in general the more pronounced and vivid the smaller the crystals are which compose the screens. The sparks are most likely due to cleavages taking place in the crystal, and not to the mere impact of the positive ions. He finds that there exists here an analogy to the scintillations observed on breaking a piece of sugar.

Proportion of Deviable Rays  $\beta$  in the Radiation of Radium.—From their experiments made by the electrical method, the Curies, with a thin layer of the radiant substance found the proportion was as 29 to 100; with a layer five times as thick, they were as 45 to 100.

Penetrating Power of the Radiation of Radio-Active Bodies.—The radiations of radium have the power to penetrate opaque solids as does the X ray.

The rays emitted by radio-active bodies into the air are projected rectilinearly. This is shown by the clearness and the form of shadows furnished by the interposition of bodies opaque to the radiations between the source and the sensitive plate.

Distance to which Radium Rays are Propagated in the Air.—The gross mass of radium radiation is limited in the air to a distance of about 7 cm. from the source. After a certain distance, the intensity of the radiation varies inversely as the square of the distance from the condenser of the apparatus.

The following experiment of Madame Curie's is beautifully illustrative of the distance to which the different rays

---

<sup>1</sup>Comptes Rendus, October 27, 1903.

are propagated. The radium salt was placed in a glass bottle. The rays which go out from the bottle traverse 30 cm. of air and are received upon a series of glass plates of 1 mm. in thickness, 3 in number; the first plate transmits 49 for 100 of the radiation which it receives, the second transmits 84 for 100 that it received, the third transmits 85 for 100 that it received.

Ionizing Action of Radium Rays.—M. Curie has shown that the rays of radium and the rays of Roentgen act upon dielectric liquids as upon air, while communicating to them a certain electric conductivity. The rays of radium strongly ionize the air. By the action of radium there can easily be provoked the condensation of supersaturated vapor of water exactly as with cathode rays, Roentgen rays, and ultra-violet rays. Under the influence of radium radiations, the explosive distance between two metallic conductors for a given difference of potential is increased; in other words, the passage of the spark is facilitated by the action of the rays. This phenomenon is due to the action of the most penetrating rays. An enclosing envelop of lead 2 cm. thick about the radium enfeebles the action of the radium upon the spot but very little, while the radiation penetrating this thickness of lead is but a very small fraction of the total radiation.

Radium Radiations Render the Air Conductive.—By the action of the radio-active substances the air is made conductive in the vicinity of two metallic conductors of which one is grounded, i.e., bound to the earth, the other to a well-insulated electrometer. Under these conditions the electrometer takes a permanent deviation.

Fluorescent and Luminous Effects.—There are a great number of substances susceptible of becoming phosphorescent or fluorescent by the action of the Becquerel rays. Becquerel<sup>1</sup> studied this action upon the salts of uranium, the diamond, etc. M. and Madame Curie first discovered the phenomenon in making polonium act through a leaf of

---

<sup>1</sup>Curie.

aluminum upon a layer of platino-cyanid of barium. It has been shown by M. Bary<sup>1</sup> that the salts of the alkaline metals and alkaline earths which are all fluorescent under the luminous rays and the Roentgen rays, fluoresce equally under the action of radium rays. Paper, cotton and glass also become fluorescent in the vicinity of radium. The author has observed that the cotton which comes wrapped around the little tubes of radium glows luminously in the dark. Of the different kinds of glass, Thuringian glass is especially luminous. Metals do not appear to become luminous. This effect of radium can be observed at a distance of two metres (Curie). Phosphorescent sulphid of zinc becomes extremely luminous and preserves its luminosity for some time after exposure to the radium. This fluorescence produced by radium may be observed even when an absorbing screen is placed between the radium and the fluorescent screen. Madame Curie has observed the illumination of the platino-cyanid of barium through the human body. The action is much more intense, however, when the screen is placed directly against the radium. The luminosity of fluorescent substances produced by radium diminishes with time. At the same time the fluorescent substance undergoes a transformation. They reduce silver salts, peroxid of iron, and bichromate of potash in presence of organic substances; while glass, porcelain and white paper are colored by them, yellow platino-cyanid of barium is transformed into the brown variety, which is much less luminous. This transformed platino-cyanid of barium is partially regenerated by the action of light. Paper becomes altered and brittle, resembling finally a colander riddled with holes.

Becquerel in referring to the chemical action of radium rays, states that white phosphorus is transformed into red in twenty-four hours, mercuric chlorid in the presence of oxalic acid is reduced with a precipitation of calomel, and after long exposure the germinating power of seeds is

---

<sup>1</sup>Curie.

destroyed. To the same chemical action the coloration of glass, porcelain, paper, and certain crystals as well as the painful physiological effects are due. Glass is colored brown or violet and at the same time becomes less fluorescent. The coloring of glass by radium rays finds its counterpart in the coloring of X ray tubes. Those who have tubes steadily in use have noted that often they assume a violet tinge similar to the coloration produced by radium rays. It is also found by Becquerel that radium rays have the same power as the electric spark under exposure to heat, of restoring phosphorescent properties to a body deprived of them by overheating. The same is true of ultra-violet light. If this glass be heated it becomes decolorized and at the same time that the decolorization is produced, the glass emits light. After that, the glass recovers the property of fluorescence in the same degree as before the transformation. Sulphid of zinc which has been exposed to the action of radium for a sufficient time becomes exhausted little by little and loses the faculty of being phosphorescent, perhaps under the action of radium, perhaps under the action of light.

Diamonds exposed in the dark to radium rays fluoresce and scintillate in the most brilliant fashion. False stones are therefore easily detected.

The action of radium Roentgen rays and ultra-violet light on minerals and gems in relation to the production of fluorescence, a luminosity during exposure, and phosphorescence, a luminosity persisting after exposure to the source of radiations, has been most exhaustively studied by Dr. George F. Kunz and Professor Charles Baskerville.<sup>1</sup>

The most responsive of all the stones examined, however, were the diamonds containing that peculiar substance which gives them what is known as the blue-white color, fluorescent, like anthracene, and holding the luminosity for a long time, to which Kunz gave the name of Tiffanyite.

“Almost all diamonds, of various weights and from many

---

<sup>1</sup>Science, December 18, 1903.

localities and of different colors, fluoresce and phosphoresce more or less with radium, except the black or carbonado. The degree to which these phenomena are observed is no criterion of the grade of the gem, however, as stones with flaws often fluoresce with even greater brilliancy than the pure ones."

They concluded from their study of the collection, that one or the other of these forms of luminosity and activity may have a value to detect elements or compounds that have escaped notice, or are present in the minerals as impurities.

The same observers found that actinium also produced a brilliantly luminous effect upon willemite when incorporated with it, but did not possess the penetrating power of radium, as the actinium did not affect the willemite outside of the glass enclosing jar, although the glass was only  $1\frac{1}{2}$  mm. thick.

Emission of Gas in Presence of the Salts of Radium.—A solution of bromid of radium discharges gases in a continuous manner, principally hydrogen and oxygen.<sup>1</sup> The composition of the mixture is near to that of water. There is a decomposition of water in presence of the salts of radium. It has been observed by one of the physicians in attendance upon the author's teaching clinic, that the ulcerated surface of an epithelioma, upon exposure to radium, "bubbled" as in electrolysis. The author has constantly noted that these surfaces after a radium treatment are moist as after an electrolysis.

The solid salts of radium, chlorid and bromid continuously emit gas. The pores of the solid salts are filled by these gases, and they are emitted in great abundance when the salt is dissolved. There is formed in the gaseous mixture hydrogen, oxygen, carbonic acid and helium; the spectrum of these gases present some unknown lines. Madame Curie describes the two following accidents occurring during M. Curie's experimental work, and due to the emission of gases:

---

<sup>1</sup>Giesel, Ber. 1903, p. 347.

A flask of thin glass filled almost full of solid bromid of radium, dry, exploded two months after its closure under the influence of a slight heating. The explosion was probably due to the pressure of the gas inside. In another experiment a flask containing chlorid of radium which had been prepared for a long time, communicated with a reservoir of considerable volume in which was maintained an almost perfect vacuum. The flask having been submitted to a rapid heating up to  $300^{\circ}\text{C}$ ., the salt exploded. The flask was broken and the salt was projected to a distance; there must have been considerable pressure in the flask at the moment of the explosion. The apparatus had before been submitted to a trial of heat under the same conditions in the absence of the salt of radium and no accident was produced.

Evolution of Helium from Radium Bromids.—This phenomenon was first observed by Sir William Ramsay.<sup>1</sup> He observed that radium gave off a heavy gas, which, when collected in a glass vacuum tube and sealed off, was found by spectrum analysis to have changed in the course of some days from radium into helium. This phenomenon was also studied by Dewar and Curie,<sup>2</sup> who observed a change of radium into helium.

Emission of Heat by the Salts of Radium.—The phenomenon of the emission of heat is unique and unprecedented and a given specimen emits sufficient heat in an hour to melt its own weight in ice, while it maintains itself at a temperature of  $1.5^{\circ}\text{C}$ . above that of the surrounding medium. Nor is it affected by a wide range of temperature, the emission of heat going on without perceptible variation, whether on a summer day or at the temperature of liquid air. The excess of temperature depends also on the thermic isolation of the substance. Madame Curie and Laborde found that the amount of heat produced by one gramme of radium per hour is about 80 calories.

In liquid hydrogen, however, radium shows that it is not

---

<sup>1</sup>Ramsay and Soddy: *Phys. Zeitschr.*, Sept. 15, 1903.

<sup>2</sup>*Comptes Rendus*, Jan. 2, 1904. *London Elec.*, Feb. 12, 1904.



always unaffected by external temperature, for within a comparatively short distance of the absolute zero, the emission of heat, so far as present data can be relied upon, is augmented at the temperature of liquid hydrogen. This extraordinary phenomenon is increased in intensity at a point where all but the most powerful chemical affinities are in abeyance. This tremendous evolution of radiant energy goes on perpetually without combustion, without chemical change of any kind, without alteration of the molecular structure of the radium salt and without appreciable loss of weight. For one square inch of surface this loss of weight in ten million years is estimated at but one gramme. Apparently these facts are a violation of the law of conservation of energy. This result is not to be explained on the view that radium gains its heat from an external source, but upon the disintegration theory, whereby its own intra-atomic energy is converted into heat. On that theory the energy of radio-activity is derived from the internal energy of the atom liberated when it breaks up into smaller systems. As the atom breaks up the so-called  $\alpha$  rays are pitched away with extreme violence, and they generate heat when they are stopped by any obstacle. In other words, radium converts its own intra-atomic energy into heat. When a salt of radium is first prepared it emits a relatively feeble quantity of heat. But this delivery of heat increases, tending toward a determinate value, which is not yet entirely attained at the end of a month. According to Rutherford and Barnes,<sup>1</sup> the heat emission of radium is probably due in part to the kinetic energy of the expelled  $\alpha$  particles and in part to the energy released consequent upon the rearrangement of the components of the systems left behind after the expulsion of the  $\alpha$  particles.

**Production of Thermo-Luminescence.**—Certain bodies, as fluorin, become luminous when they are heated; they are, therefore, thermo-luminescent. At the end of a certain time

---

<sup>1</sup>Phys. Rev., Feb., 1904.

their luminosity fades, but the faculty of becoming luminous anew by heat is restored to these bodies by the action of a spark, and also by the action of radium.

Photographic Power of Radium.—The rays which act photographically are the  $\beta$  and  $\gamma$  group. Unlike the Roentgen rays, there exists no difference between the transparency of the flesh and the bones. This is shown in the accompanying cuts of a mouse, a mouse in a trap, and a dead hand originally loaned the author by Mr. W. J. Hammer<sup>1</sup> for a monograph on radium.

To the courtesy of Mr. Hammer the author is indebted for their reproduction in this connection. These cuts are introduced as illustrative of the fact, that in radium-graphs, unlike radiographs taken with the X ray, there exists no difference between the transparency of the flesh and bones.

That of the mouse was made in 24 hours by laying it directly on the plate, and that of the mouse in a trap in 3 days. In the latter the wooden part of the trap is transparent as with the X ray. The dead human hand was exposed for 8 days. A slight trace of the bones can be seen. It is supposed to be the first picture of the human hand made with radium.

Radiographs may be taken with radium at considerable distances, and with sources of small dimensions. A much more beautiful radiograph may be made if the  $\beta$  rays be deflected by a magnetic field and the  $\gamma$  rays only utilized. There is produced a certain confusion and a certain blur by the  $\beta$  rays. A longer exposure is required when they are suppressed, but the results are better.<sup>2</sup> A *portemonnaie* requires a day with a radiant source consisting of a few centigrammes of radium salt enclosed in a flask of glass and placed in 1 m. from the sensitive plate upon which the ob-

---

<sup>1</sup>Margaret A. Cleaves: Radium, Its Physics, Physiological Action and Therapeutic Effects, American Electro-Therapeutic Association, Sept., 1903.

<sup>2</sup>Madame Curie.



Fig. 46.—Radium-graph of a Mouse made by Radium in Twenty-four Hours.



Fig. 47.—Radium-graph of Dead Human Hand.







Fig. 48.—Radium-graph of a Mouse in a Trap.

ject is laid. The same result is obtained in an hour if the radium is placed at 20 cm. distant from the plate. A sensitive plate is immediately impressed in the immediate vicinity of the radiant source.

Induced Radio-Activity.—Substances which have been in contact with radium become radio-active and their radio-activity lasts for varying periods of time. Professor Curie states that it is impossible for him to go near his instruments to make any measurements for hours after being near radium, and those who work with it, find it extremely difficult to keep their tools, instruments and themselves free from the radio-activity imparted by the radium. Falling rain and snow are for a time quite powerfully radio-active and lightning rods and even the leaves of trees also become radio-active. It was found by McLennan that rain caught in a vessel and immediately evaporated to dryness, imparted a radio-activity to the vessel. Hammer found a piece of cardboard which had formed the box holding his radium, luminous in the dark after six days. This radio-activity was stimulated by burning magnesium wire before it.

M. and Madame Curie found that the radio-activity thus acquired is not due to a transference of radio-active particles which are deposited on the surface of the neutral substance. The induced radio-activity disappears when these naturally inactive substances are withdrawn from the influence of the radium. This induced radio-activity has been studied by the electric method, and the following facts observed: (1) The activity of a plate exposed to the action of radium increases with the time of exposure and approaches a certain limit following an asymptotic law. (2) The activity of a plate which has been activated by the action of radium, and which has been withdrawn from the action disappears in a few days. This induced activity tends toward zero in function of time, following an asymptotic law. (3) All conditions being equal, the radio-activity induced by the same radiferous product upon various plates is independent of the nature of the plate. Glass, paper, metals, are active with

the same intensity. (4) Radio-activity induced upon the same plate by various radiferous products has a limit value as much more elevated as the product is more active.

Irregular results are obtained when the "activation" is produced in free air. It has been observed by Madame Curie and Debierne that the phenomenon is perfectly regular when it takes place in a closed vessel.

Activation in a Closed Receptacle.—If a little flask containing radium open at the top be placed in the centre of a closed receptacle, and then various metallic plates placed around it, the latter become radio-active at the end of the day. If the dimensions are equal, the activity is the same whatever their nature, whether of lead, aluminum, copper, glass, ebonite, wax, cardboard, or paraffin. The activity of the face of one of these plates is as much greater as the free space before this space is greater. If the experiment is repeated with the flask enclosed no induced radio-activity is obtained. Radio-activity may be transmitted by the air, gradually from the radiant source to the body to be acted upon. It can even be transmitted to a distance by very straight capillary tubes. The action is both more intense and more regular when an aqueous solution of the solid salt is used than with the salt itself. Liquids are capable of acquiring radio-activity, pure water, for example. When placed in a radio-active enclosure certain phosphorescent and fluorescent bodies become luminous, glass, paper, cotton, water and saline solutions, for example. The limit of induced radio-activity is independent of the nature and pressure of the gas present in the "activating" solution. It depends upon the quantity of radium enclosed in the state of solution and seems proportional to it.

Rôle of Gases in the Phenomena of Induced Radio-Activity.—Gases present in a radium enclosing receptacle, either salt or solution, become radio-active. This radio-activity persists even when the gas is aspired but finally disappears entirely. This radio-active energy enclosed in gases exists in a special form. Rutherford supposes that



certain radio-active bodies, radium, thorium and actinium, are constantly emitting a material gas which he calls emanation.

Disactivation.—By this is meant the loss of radio-activity. When a solid body which has been exposed for a sufficiently long time, and is then withdrawn into the free air it loses its radio-activity. This loss follows definite laws and has been determined mathematically. This law of disactivation is such that the intensity of the radiation falls one-half of its value in 28 minutes. Disactivation takes place much less rapidly in a closed vessel than in the free air, and by the mathematical formulæ it has been found that the intensity of the radiation under these conditions diminishes one-half in four days. For temperatures between  $180^{\circ}$  and  $450^{\circ}$  this law remains the same.

Rutherford<sup>1</sup> has shown that heating has an enormous effect on the issue of the emanation from radium. Experimentally it was shown that 19/20 of the ionization was due to the emanation when the emanation was present, and that three-fourths of the ionization was due to the emanation when the latter was blown out, and one-fourth to induced radio-activity.

The molecular weight of this emanation from radium has been found by Rutherford and Miss Brooks to be between 40 and 100. This emanation is not the vapor of radium, as M. and Madame Curie have shown that the atomic weight of that substance is 225.

Elster and Geitel<sup>2</sup> have demonstrated that a very feeble proportion of radio-active emanation analogous to that emitted by radio-active bodies exists in the atmospheric air.

Radium emanations are also found in the air extracted from certain mineral waters, while the air of the waters of the sea and rivers are scarcely exempt. The air from a tube forced into the ground is particularly charged with emanation. The waters of a number of mineral springs famous

---

<sup>1</sup>Quoted by Thomson.

<sup>2</sup>Physik. Zeitschr., Sept. 15, 1902.

as health resorts have been analyzed to ascertain to what degree they were radio-active. Among these may be mentioned those of Bath. Dewar<sup>1</sup> had found the element helium present in these waters, and Strutt<sup>1</sup> found that the deposits in the tanks and at three of the Bath springs contain radium in appreciable quantities, though not enough to pay for extraction. He thinks there can be little doubt but that the helium of Bath owes its origin to large quantities of radium at a great depth below the earth's surface. A little of this radium is carried up by the rush of hot water, and it is found in the deposit.

The deposit which Mr. Strutt examined is one of countless peculiar features of the Bath waters. It settles on walls and the bottoms of tanks and corrodes pipes, being like mud of a rich orange color. When dry it is orange-colored powder, but duller in hue and very fine in substance. Settling on stone or projections, it hardens and assumes the appearance of coral or fungus.

J. J. Thomson<sup>2</sup> found that the radio-active gas found in Cambridge tap water possessed properties similar to the emanation of radium. Professor Bumstead<sup>3</sup> of Yale found the radio-active gas in the ground and the surface water near New Haven to be identical with the emanation from radium. Many different springs have been exploited in the daily press as radio-active. It might be supposed that radium emanations were present in the gas of the waters of the river Jordan into which the Syrian Naaman dipped himself seven times as directed with the result of the healing of all his sores, his flesh becoming soft and smooth as a baby's. It is quite conceivable that a substance undergoing such constant change and disintegration as does an atom of radium may fling off from itself something of therapeutic value. Such substances in a nascent form would be more active and therefore the inefficiency of the waters of certain springs

---

<sup>1</sup>Elect. World and Eng., Editorial.

<sup>2</sup>Phil. Mag., Nov., 1903.

<sup>3</sup>N. Y. Sun, Feb. 1, 1904.

when removed from their source might be explained. Nor is it possible to imitate these springs artificially successfully.

Nature of the Emanations.—Rutherford<sup>1</sup> regards it as a material radio-active gas. From many points of view the radium emanation comports itself as an ordinary gas. Emanations from thorium and radium do not seem to be altered by various very energetic chemical agents, and for this reason they are likened by Rutherford and Soddy to some gas of the family of argon.

Induced Radio-activity Varies with Different Substances.—The laws formulated for induced radio-activity do not cover all substances. Celluloid, paraffin, caoutchouc, etc., are disactivated very slowly, more than the laws given permit. They have been known to retain their induced radio-activity from 15 to 20 days. There are again other bodies, such as plates of copper, aluminum and glass, which at first follow the law of disactivation; but when the activity has fallen to about  $1/20000$  of the initial value, it diminishes neither more nor less. It develops very slowly, sometimes even it continues to increase. The Curies have some such substances which have been radio-active for more than six months. In this connection it may be mentioned that McClennan and Burton<sup>2</sup> from their experiments regard metals generally as radio-active.

Radio-activity Induced upon Substances which Remain in Solution with Radium.—This was observed by the Curies in the work of chemical separation to isolate radium salts. All the substances in the mineral are found in a more or less induced radio-active state. The induced radio-active bodies disappear in proportion as the radiant bodies become concentrated. The induced radio-activity of laboratory apparatus has been referred to. The dust and air of the room also become radio-active. The air of the room is a conductor. Says Madame Curie, "In the laboratory where we work the

---

<sup>1</sup>Phil. Mag. 1902, p. 580, 1903, p. 457, quoted by Madame Curie.

<sup>2</sup>Phil. Mag. Sept., 1903, Abst. Electrical World and Engineer, Oct., 1903.

evil has arrived at an acute state and we can have no longer a well-insulated apparatus.”

Variations of Activity of the Radio-Active Bodies. Effects of Solution.—Polonium diminishes in radio-activity as time goes on. In a specimen examined, in 6 months 67/100 of its activity is lost. Contrary to this, the radiferous salts possess a permanent radio-activity which does not present appreciable loss at the end of some years. A salt of radium prepared in the solid state does not at first show a constant activity. Its activity goes on increasing and attains a value limit at the end of about a month. The contrary is the fact for a solution. First prepared it is very active, but left in the air it becomes rapidly disactivated, and finally attains an activity limit which may be considerably more feeble than the initial value. These variations were first observed by M. Giesel.<sup>1</sup>

Time Taken for Activity to Fall to Half its Value.—The duration of the activity of a radio-active substance is the property by which it is most easily recognized. Therefore the following table showing the time taken to fall half its value in those cases in which it has been determined.<sup>2</sup>

Thorium emanation, one minute.

Induced activity due to thorium, 11 hours.

Radium emanation, 4 days.

Induced activity due to radium, 28 minutes.

Actinium emanation, a few seconds.

Induced activity due to actinium, rather less than 28 minutes.

Radio-active gas from water, 4 days.

Induced radio-activity due to this gas about 40 minutes.

Induced radio-activity on a negatively electrified wire in the open air, about 40 minutes.

If radio-active waters artificially produced are to have any value for therapeutic purposes, they must, according to the above, be used when first prepared.

<sup>1</sup>Wied. Ann. t. LXIX., p. 91, quoted by Curie.

<sup>2</sup>Thomson: Conduction of Electricity through Gases.

Theory of Radio-Activity.—Curie and Debierne<sup>1</sup> advance the theory that each atom of radium functions as a constant and a continuous source of energy, without being precise about the source of this energy. The radio-active energy which accumulates in radium tends to dissipate itself in two different fashions: (1) By radiation (rays charged and not charged with electricity); (2) by conduction, that is to say, by transmission gradually to neighboring bodies, by the intermediary of gases and liquids (emission of emanation and transformation into induced radio-activity).

Nature and Cause of the Phenomena of Radio-Activity.—The rays given off by radium are analogous with the group of rays which exist in Crookes tubes, cathode rays, Roentgen rays and canal rays. These are also the same group of rays found in the secondary radiation produced by Roentgen rays<sup>2</sup> in the radiations of the bodies which have acquired the induced radio-activity. While the nature of the phenomenon is actually better known, the cause of spontaneous radio-activity remains mysterious. Says Madame Curie, "And this phenomenon is still for us an enigma and a subject of profound astonishment."

Is the energy created in the radio-active bodies themselves or is it borrowed by these bodies from exterior sources? Experiments, says Madame Curie, do not confirm any of the numerous hypotheses arising from these two ways of looking at the subject.

The hypothesis of atomic transformation of radium is supported by the most recent researches. This was believed by the Curies and also by Rutherford<sup>3</sup> from the first. The recent experiments of the latter tend to prove that the emanation is an unstable gas which is destroyed in giving place to a production of helium. The continuous output of heat furnished by radium cannot be explained by any ordinary

---

<sup>1</sup>Curie et Debierne, *Comptes Rendus*, 29 Juillet, 1901.

<sup>2</sup>Sagnac, *Thèse de Doctorat*.—Curie and Sagnac, *C. R.* Avril, 1900.

<sup>3</sup>Rutherford and Soddy, *Phil. Mag.* May, 1903.

chemical action, but might have its origin in the transformation of the atom. The new radio-active bodies, says Madame Curie, are always found in the minerals of uranium and they have vainly sought for them in the barium of commerce. The presence of radium, therefore, seems allied to that of uranium. These uranium minerals contain besides argon and helium, which cannot be regarded as due to chance. The simultaneous presence of these bodies suggests that the presence of one may be necessary for the formation of the other. Or again, instead of the atom of radium being transformed, perhaps this atom is stable but acts upon the medium which surrounds it, in a manner to give place to atomic transformations.

This hypothesis leads to the admission of the possibility of transformation of the elements; but radium itself would then be no more than an element on the road to destruction.

The Action of Radium on Bacteria.—Danysz<sup>1</sup> found that the salts of radium dissolved in distilled water emit certain emanations which prevent the development of Anthrax bacilli. E. Aschinass and W. Caspari<sup>2</sup> found that the germs of the micrococcus prodigiosus when exposed to a radium preparation were effectively killed in about three hours by the action of the ray.

Caspari expressed himself as follows to the Society of Internal Medicine of Berlin, July 6, 1903: "The rays of Becquerel have a bactericidal action. Experiments have been made upon the bacillus of tuberculosis in introducing them into the anterior chamber of the eye of the 'cobaye,' and also injecting some radio-active substance. There was no infection. Diphtheritic bacilli provoke, on injection into the muscles of the 'cobaye,' œdema, inflammation, then necrosis of tissue; if this injection is followed immediately by an injection of insoluble radio-active substances, there is produced no necrosis and there is favorable action upon the

---

<sup>1</sup>Rev. Internat. d'Elec.

<sup>2</sup>Ann. der Physik, t. VI., 1901, p. 570.

pathological process. The animals which have received the radio-active injection discharge the electroscope, and their blood becomes radio-active. Theoretically, it is necessary also to admit the possibility of an action upon carcinoma, for radium causes its disintegration." Caspari used the radio-active salt of barium.

Hoffman<sup>1</sup> sought to confirm the results obtained by Aschinass and Caspari. Five milligrams of pure bromid of radium was placed for three hours in the incubator at 23°C., at 3 millimetres and a half distance from the culture, then it was withdrawn, and 23 hours after, microscopically, the parts which had been submitted to the influence of radium showed no colony of bacteria, and all the spores were absolutely destroyed.

Pfeiffer and Friedberger<sup>2</sup> experimented with 25 milligrams of bromid of radium placed in a capsule of nilconite, surrounded with a plate of mica, the whole protected by an envelope of copper provided with a central window. The rays engendered by this small quantity were capable of traversing a plate of bronze 5-6 millimetres thick. The first experiments, made at a distance of 6-10 cm. upon the cholera and typhoid bacilli, were negative. The cultures were finally placed at a distance of 1 cm. from the radium. If, first, the gelatin is exposed before culture to the action of the rays, the gelatin undergoes no modification capable of preventing the development of the cultures when later inoculation is practiced. They found that the spores of anthrax succumb at the end of three days of exposure.

Mr. Henry Crookes, May 15, 1903, at a *Conversazione* of the Royal Society, showed plate cultures of several kinds of bacteria which had been exposed to a radium emanation through a mica screen. The results proved the "bactericidal effects of electrons from radium."<sup>3</sup> It was found in every

---

<sup>1</sup>Hygienische Rundschau, XIII., 18; Anal. in *Revue de Therapeut.*, 15 Octobre, 1903.

<sup>2</sup>Rev. Internat. d'Elec., Jan., 1904; from *Berlin klin. Wochenschrift*, 13 Juillet, 1903.

<sup>3</sup>Medical Electrology and Radiology, Editorial, Jan., 1904.

case that the organisms were killed in those places where they had been exposed to the action of over 10 milligrams of radium bromid. On incubation a bare space free from bacterial growth was left on the plate opposite the point where the radium had been placed. The organisms so exposed were bacilli liquefaciens, bacilli coli communis, and bacilli prodigiosus.

The Action of Radium on Vegetable and Animal Organisms.—M. Giesel has remarked the action of radium upon the leaves of plants. The leaves submitted to its action grew yellow and fell.

Professor A. Danilewsky<sup>1</sup> makes the observation that he has seen the movements of young infusoria stop under the influence of radium, while those of the adult infusoria were not modified under the action of this substance.

M. Danysz showed the destructiveness of radium to the life of mice, rabbits, guinea pigs, chickens in embryo and vegetables.

His experiments further proved the vivifying influence of radium when used in a milder form. It also was used to the point of arresting transformation of the larvæ and some species grew to a very much greater size. Angle-worms that were exposed to radium rays crawled away from their direct influence and lived, while others that were confined directly to the stronger influence of the rays were killed. Caterpillars became paralyzed and died when exposed to the action of radium.

Experiments were made by M. Böhn at the Biological Laboratory in Paris for the purpose of determining what modification radium rays will have on lower forms of life. Mr. Böhn created monsters of the tadpole and there was a change in their breathing apparatus. He had used radium for the purpose of altering fecundated species. He used radium to create life in the unfecundated eggs of the sea-

---

<sup>1</sup>Conference méd. de la clinique des maladies mentales et nerveuses à Saint-Petersbourg, le 18 Sept., 1903 in Roussky Vratch, 1903, No. 47.



urchin and it is claimed that they were advanced through several stages of development.

Radiumized meal worms die, but those which live on show such retardation, that while those of the control test pass through the cycle of life, becoming beetles which lay eggs, which grow to worms, during the allotted three months, and repeat this cycle three or four generations, the radium worms still remain meal worms. They have been said to be veritable Methuselahs.

Dr. London, of St. Petersburg, found that when a box containing radium bromid was placed in a cage in which mice were kept, the animals became paralyzed and comatose, and died in five days.

Destructive Action of Radium.—Danysz is quoted as having said: "I have no doubt that a kilogram of radium would be sufficient to destroy the population of Paris, granting that they came within its influence. Men and women would be killed just as these mice are killed. They would feel nothing during their exposure to the radium nor realize that they were in any danger. Weeks would pass after their exposure before anything would happen. Then gradually the skin would peel off and their bodies would become one great sore. Then they would die from paralysis and congestion of the spinal cord."

Action of Radium on Chlorophyll Containing Organisms.—The most recent published experiments on the effects of radium on the lower organisms are those of E. G. Wilcox.<sup>1</sup> Wilcox has experimented with a number of chlorophyll containing organisms, and has found that those, and those only, are sensitive to the action of the rays. To the  $\beta$  rays there was a definite radiotaxis. In the course of a few hours all the animals moved out of the path of the pencil of  $\beta$  rays. Non-containing chlorophyll organisms did not seem to exhibit this power, although they speedily disintegrated under the influence of the rays. Of especial interest were the ex-

---

<sup>1</sup>Journal Physiology, Cambridge, 30, p. 449. Also Medical Electricity and Radiology, August, 1904.

periments upon two common forms of hydra. *Hydra viridis* showed great power of resistance to the rays when prevented from moving out of their sphere of influence, although whenever possible the animal would move out of the path of rays as quickly as possible. *Hydra fusca*, on the other hand, which does not contain any chlorophyll, did not move out of the rays, but was quickly killed by them. The animals were bisected, a procedure in these animals which is followed, by no great interference with their normal course of existence, in order to determine which part of the animal was susceptible to the ray. The oral disc was found to be the most susceptible, only this half moving out of the path of the rays. Chlorophyll is a fluorescent substance, and there is undoubtedly a relation between its fluorescent properties and its protective and sensitizing powers. This point is of especial interest in that the chlorophyll in those animals is probably only contained in the cells of commensal algæ, and exhibits in a very marked way the mutual relationship existing between the alga and its host. The *Opalina ranarum*, a colorless organism, did not exhibit any sensitiveness to the rays. Thus far the  $\beta$  rays only have been experimented with, a disc of lead being interposed between the organism and the radium. Exposure to the unprotected radium was more marked, *hydra viridis* even being affected and disintegrated. The effect of chlorophyll was seen in this case, the green variety being more resistant than the brown.

Physiological Effects—The Action of Radium upon the Skin.—Becquerel, Giesel, the Curies, and others have given important evidence as to the serious physiological effects of radium. Becquerel from carrying a specimen in his pocket for six hours received a serious burn on his abdomen.<sup>1</sup> Hammer<sup>1</sup> felt the effects for weeks from carrying a wooden box containing eight tiny tubes under his arm for several hours.

M. J. Danysz, in a report to the Academy of Sciences, states that the application of a tube containing a salt of

---

<sup>1</sup>"Radium Selenium and Ultra-violet Light," Hammer W. J.

radium to the skin produces an ulcer in from 8 to 20 days. A few moments' application is followed by a congestion of the human skin. When applied to the skin of a rabbit destruction of the epidermis follows, but when applied under the skin there is only a feeble reaction on the epidermis. It seems to penetrate the muscles with difficulty. Danysz also found that the intestines and the serous surfaces, when the tubes containing the radium were introduced into the cavity of the guinea-pigs and allowed to remain for several hours, were but little affected and no lesions produced comparable to those of the skin.

The action of radium rays upon the epidermis was first observed by M. Walkhoff,<sup>1</sup> and confirmed by M. Giesel,<sup>2</sup> then by MM. Becquerel and Curie.<sup>3</sup>

Madame Curie gives the following interesting description of the action of radium upon the skin: If upon the skin be placed a small capsule of celluloid or caoutchouc enclosing a very active salt of radium, and left there some time, a redness is produced upon the skin, perhaps immediately, perhaps after some time, which is just so much the longer as the action has been more feeble and less prolonged. This red mark appears at the place which had been exposed to the action; the local alteration of the skin manifests itself and develops like a burn. In certain cases it forms a blister. If the exposure has been prolonged, there is produced an ulceration very slow to cure. In one experiment, M. Curie caused to act upon his arm a relatively feeble radiant product for ten hours. The redness appeared immediately, and formed later a wound which took four months to heal. The epidermis was destroyed locally, and was regenerated in the healthy state, only slowly and painfully with formation of a very marked cicatrix. A burn of radium with exposure of a half hour appeared at the end of 15 days, formed an ampulla and healed in 15 days. Another burn, made with

---

<sup>1</sup>Phot. Rundschau, Oct., 1900.

<sup>2</sup>Berichte d. deut. chem. Gesell. t. XXIII.

<sup>3</sup>Comptes Rend. t. CXXXII., p. 1289.

an exposure of 8 minutes, only occasioned a red spot which appeared at the end of two months and was insignificant in effect.

The action of radium upon the skin can be produced through metals, but it is feeble. To guarantee one's self from action, it is necessary to avoid carrying radium a long time upon the person unless wrapped in a sheet of lead.

M. Poussep<sup>1</sup> reported the formation of an ulcer upon his own skin exposed for six hours to the action of 1.5 milligrams of radium enclosed in a box. After the removal of the radium, Poussep felt nothing for 6 days. At the place exposed to the radium there then appeared a white spot, encircled with rose, of a size 3.5 cc. in diameter, and which at the end of 11 days was transformed into an atonic ulcer rebellious to all treatment. The ulcer showed a tendency to cicatrization under the influence of white light after 5½ months. This cutaneous lesion, provoked by radium, did not appear to Poussep to be a simple burn, but rather a necrotic process.

The Action of Radium upon the Eye.—M. Geisel<sup>2</sup> discovered the action of the rays of radium upon the eye. The ocular phenomenon or sensation of light when a tube is held close to the eye or near the temple is one of the most familiar of the phenomena of this agent. The phenomenon has been studied by MM. Himstedt and Nagel.<sup>3</sup> These physicists have shown that all the media of the eye become fluorescent by the action of radium, and that this explains the sensation of light perceived. The blind, where the retina is intact, are sensitive to the action of radium, while those whose retina is diseased do not have the luminous sensation due to the rays.

The action of the rays of Becquerel upon the eye has been studied by Hoffman,<sup>4</sup> who submitted every day for 6 minutes the cornea of a rabbit to the action of radium, from

---

<sup>1</sup>Arch. d'Elec. Med., Feb. 25, 1904.

<sup>2</sup>Quoted by Madame Curie.

<sup>3</sup>Ann. der Physik. t. IV., 1901.

<sup>4</sup>Revue Internationale d'Electrothérapie, Jan., 1904.

July 4 to August 2, without observing the least lesion of the cornea or of the crystalline lens. The retina alone reddened later. The pupillary reaction remained always normal.

The Action of Radium upon the Nervous System.—Recently, M. Danysz<sup>1</sup> has shown that the rays of radium act energetically upon the spinal cord and brain. After an action of an hour, paralyzes are produced in animals submitted to the experiments, and they generally die at the end of a few days. Its action upon the nerve centres was noticed in all animals subjected to experiment, but it was comparatively feeble in those whose osseous tissue protected the nerve centres. Application of the tubes containing the salt to the cranium caused paresis, ataxia, and convulsions, followed later by death.

Hammer experimented with an electric torpedo in the Aquarium at Naples by placing six tubes of radium on the back of the fish, which is shaped like a flounder, leaving them there for twenty minutes.

Prior to doing this both he and the members of his party had received powerful shocks from the torpedo's batteries. Upon removing the radium he tried for fifteen minutes to get a shock from the fish in the same manner as before, but without success. He admits that the fish "might have been out of shocks" but the question which naturally arose, was whether a partial paralysis had not been induced by the action of the radium rays. This seems more than plausible in view of the fact that Professor Curie found that a few milligrams of radium introduced beneath the skin of a mouse over the vertebral column produced death by paralysis in three hours; and tubes of radium placed in contact with the back of the neck of guinea-pigs have paralyzed these animals in a few hours, according to the length of the exposure.

The Action of Radium upon the Excitability of the Cerebral Cortex.—M. Jaukovsky<sup>2</sup> has proved that a box contain-

---

<sup>1</sup>Comptes Rend. 16 Fevr., 1903.

<sup>2</sup>Conf. med. de la Clin. des Malad. mentales et nerveuses à St. Petersburg, 18 Sept. 1903, in Roussky Vratch, 1903, No. 47.

ing 10 to 15 milligrams of radium applied upon the surface of the brain augments at first and diminishes later the excitability of the cerebral cortex. The degree and duration of the augmentation of cortico-cerebral excitability is in proportion to the quantity of the metal supplied and to the intensity of its radio-active properties. After a period more or less long of increased excitability, this diminishes gradually and falls sometimes below the normal.

Therapeutic Uses of Radium. *Lupus Vulgaris*.—M. Danlos,<sup>1</sup> at Hospital St. Louis, reports several cases treated by radium.

Case I.—Lupus of the face exposed to the action of a salt of radium, at two points, which had a radio-activity of 19,000, for from 24 to 36 hours. The result was disappearance of the disease with the formation of a smooth, white cicatrix, blending into the surrounding normal tissue.

Case II.—Lupus of face, ears, neck and hands of ten years' duration. Three different areas exposed to 5,200 radium for 24, 48 and 54 hours respectively; each of these three regions was cured while the unexposed areas remained as they were.

Case III.—Lupus of the hands of 20 years' duration. One portion treated with Finsen light, 110 sittings; improving slowly. Another portion treated with 5,200 radium, five applications of 24, 39, 39, 40 and 63 hours' duration shows marked improvement, in decided contrast to that treated by the Finsen light and in favor of the radium.

Case IV.—Lupus nodules near the eye, treated with 2,500 radium; cured.

Case V.—Extensive lupus of the hands treated with 19,000 radium, at five different areas for single exposures of 24, 36, 72, 96 and 120 hours respectively. The areas in the first four places were cured. The man then ran away from the hospital and turned up six months later at another place,

---

<sup>1</sup>Danlos; 1901 and 1902: Several articles on the treatment of lupus by radium. *Ann. de dermat. et syph.*, Paris, June 1901, p. 367; November, 1901, p. 986; and July, 1902, p. 723.

to be treated by MM. Hallopeau and Gadaud, for an ulcer on the back of his hand, caused by the radium. M. Danlos saw the case again, and recognized the ulcer as being at the location of the radium application and of the shape of the radium vial. He advised a shorter exposure in future cases. This burn was inflicted in the first series of cases in which radium had ever been used therapeutically, and when there was no standard of dosage.

Dr. Blandamour<sup>1</sup> has also used radium in lupus. His best results followed the use of salts with a radio-activity of 5,200 and 19,000 respectively.

The exposures were made from 24 to 40 hours and were followed by profound erythema with maceration of the tissues exposed and even ulceration. The recovery was perfect and the cosmetic effect good, the resulting scar being white, smooth, and soft. By modifying the power of the radium and shortening the exposure he expressed the hope that the desired effect might be obtained without ulceration.

J. A. S. Mackenzie Davidson<sup>2</sup> in charge of the Roentgen ray Service at the Royal London Ophthalmic Hospital, and at the Charing Cross Hospital, reports several cases where radium (bromid of) was used.

No. 1.—Rodent Ulcer. Had resisted treatment by X rays and Finsen light. Seven applications, extending over six weeks. Examination, four months after, showed scarcely a trace of the disease.

No. 2.—Tuberculosis verrucosa cutis. Seven applications extending over 6 weeks. Disappearance of lesion.

No. 3.—Rodent ulcer of nose. Eight applications, extending over two months. Case cured.

No. 4.—Epithelioma of right side of face. Three operations. Treated by X rays. No arrest. Six applications, extending 6 weeks, marked improvement in course of which two erysipeliform attacks took place, after which treatment

---

<sup>1</sup>Sem. Medicale Ians, 1903.

<sup>2</sup>Brit. Med. Jour. 23 Jan., 1904.

resumed. Improvement was slow but regular. Salivation diminished, the tongue became normal, the appetite reappeared, cicatrization progressed and it seems perfectly legitimate to hope for complete cicatrization.

No. 5.—Nævus, degenerated with characters of malignancy, which disappeared after a few applications of a single tube of radium.

Epithelioma of the lower part of the right cheek. Treatment consisted of applications for 15 minutes of 5 milligrammes of bromid of radium enclosed in a tube of glass. After the first application the patient experienced relief from pain. After 5 séances, no more hemorrhages took place; pain and sensibility had disappeared. After 7 séances granulations of good quality appeared. The ulceration was deep and was long in cicatrizing; it left a depressed cicatrix.<sup>1</sup>

Mackintyre<sup>2</sup> has reported two cases of lupus treated by radium.

Lupus of the nose and hand; the area on the hand was a half inch in diameter; treated by radium (strength not given, probably a German preparation), exposed daily 20 to 30 minutes for three weeks and completely healed.

Lupus of the nostril and nose, one inch in diameter; treated similarly daily for 4 weeks and cured. This case had been under treatment in the previous year by the Finsen light, and had disappeared only to recur in two months.

Holzkecht adds another case of lupus.

Lupus tumidus that became flatter under both Finsen light and radium. For some reason the treatment was continued under the Finsen light.

Dr. Robert Abbe<sup>3</sup> adds still another case of lupus of the face, treated by a single exposure of an hour and a half to

---

<sup>1</sup>Gerald Sichel, Chief of Actino-therapeutic service, Guy's Hosp. (Brit. Med. Jour. Jan. 23, 1904).

<sup>2</sup>Mackintyre, John; July 25, 1903, and June 6, 1903; On the therapeutic effects of the salts of radium. Brit. M. J., Lond., p. 199.

<sup>3</sup>Abbe, Robert; November 10, 1903: The Status of Radium. Address before the Mercer County District Medical Society, at Trenton, N. J. (Not published.)



300,000 radium, with complete disappearance of the lesion when the patient was next seen one month later.

In addition to these lupus cases, several other skin diseases have been reported as treated by radium.

*Verruca Vulgaris*.—Abbe<sup>1</sup> reports five cases of the ordinary wart cured by means of radium. The results were equally satisfactory no matter how long standing the case. The radium, 2 grains of 300,000 radio-activity, was placed in contact with the wart for one hour from one to four times. In from 3 to 4 days a pink zone appears about the base of the wart and it begins to flatten. Usually it disappears inside of 10 days, leaving a smooth skin.

Radium in Blindness.—Javal and Curie<sup>2</sup> have made numerous studies with a very active radium salt, placing it into a covered glass vessel, and this into a dense pasteboard box through which no ordinary light could pass. Two absolutely blind men, one as the result of optic nerve atrophy, the other through glaucoma, did not perceive the presence of the light at all. A third individual, afflicted with prolapse of the retina, retained light perception in a small portion of his visual field. When exposed to the radium rays he announced at once the appearance of a light and precisely in that part of his visual field which corresponded to the inviolate portions of his retina. A fourth individual, blinded by ophthalmia neonatorum, had thick corneal scars, form perception was completely lost, color perception was present to a slight degree. Exposed to the radium rays he at once noticed a lighting up of his visual field, even after the eye was covered with both hands; were it possible to make his cornea transparent he could be given perfectly satisfactory vision. In a fifth case the eye had become glaucomatous after an iridectomy, and all form perception was lost, light perception was retained; later the lens became cataractous, and light perception also failed. A consultant blaming the light blindness on the cataract, wanted to operate. Knowing that the sensitive

---

<sup>1</sup>N. Y. Med. Record, Aug. 27, 1904.

<sup>2</sup>American Medicine, April 25, 1903.

retina would have perceived the approach of the radium light, we could inform him that the removal of the cataract would not be of the least service in this case.

London<sup>1</sup> has found by research that a box enclosing 0.3 of a gram of bromid of radium placed in proximity to the eye or even near the cranial vault provokes in man, whose eye has previously been kept in darkness, a strong luminous sensation. The rays of radium produce in the retina fluorescent properties; they are retained by the various media of the ocular globe without being reflected, and without the least refraction. They do not augment the acuteness of vision, but they excite very probably the visual centre.

Experiments made upon a rabbit showed that a prolonged action of radium upon the eye provokes in the latter inflammatory phenomena which only appear four weeks after the application of the radio-active rays. London has utilized the fluorescent properties of radium to teach certain blind subjects, suffering from atrophy of the optic nerve, but having preserved a part of the retina, to distinguish clearly upon the fluorescent screen letters, figures, and even to decipher entire words.

Subsequent to London's experiments, the action of radium on the eye was studied by Professor Greef<sup>2</sup> at La Charite, Berlin. His conclusion "that nothing in aid of the blind is to be expected from radium" receives the author's unqualified endorsement.

Radio-Active Substances in Neuralgia.—Foveau de Courmelles,<sup>3</sup> on the strength of experiments on mice performed by M. Danysz, of the Pasteur Institute, and the paralytic symptoms produced, regarded the resulting sedation as due to paralysis of the sensory nerves of the region treated, a paralysis which may by repeated subjection to the rays be carried to the point of deadening of the nerve fibers

---

<sup>1</sup>Archives des Sciences Biologiques de St. Petersburg, t. X. No. 2, 1903.

<sup>2</sup>Deutsche Med. Wochenschrift.

<sup>3</sup>Progrès Médical, May 28, 1904.

equivalent to the effects of stretching or section of the nerve, with a sort of elective action on the morbid tissues. Pain, whether that of facial neuralgia or that of cancer, may be treated with success by means of local applications of radium chlorid, sometimes as frequently as three or four times a day, each application lasting for a quarter of an hour. Courmelles has found it simpler and free from the risk of dermatitis to apply plasters of oxid or nitrate of thorium. M. de Courmelles regards thorium as a "poor relation" of radium, possessed of no phosphorescence and of only two or three times the radio-activity of uranium. It may be left in position without danger, and the cure of very obstinate facial neuralgia obtained. A plaster of oxid of thorium is made in the shape of a sort of varnish, or the powder may be wrapped in tinfoil and applied to the seat of pain. If this is reinforced by the use of radium the result is reached more speedily. The action of the radium is concentrated by the tinfoil wrapper of the thorium, and the latter contributes its own power.

He refers to three cases of the successful employment of this treatment of facial neuralgia of several years' duration, in two of which the nerve had in vain been stretched and then divided. The simultaneous use of radium and thorium effected a cure in from three to eight days. Besides being free from danger, thorium has the advantage of being cheap. In his experience applications of acid nitrate of thorium, together with those of the high frequency current, have given excellent results in cases of lupus erythematosus.

Courmelles' experience is in accord with the action of radiant energy in painful nerve affections.

Exner<sup>1</sup> reports nine cases of cancer in which radium has effected very considerable lessening of the swelling and in two of these cases the swelling has not reappeared, although five months have elapsed since the treatment.

He believes that radium rays irritate the cells of the strata

---

<sup>1</sup>London Elec., Nov. 6, 1903.

of the skin less vehemently than they irritate the cells of cancer and sarcoma. The latter are brought to necrosis before the other tissues suffer severely from the effects.

Plimmer<sup>1</sup> regards it as probable that "the emanations from radium can only act upon young and rapidly growing cells, and that older cells, especially if surrounded by fibrous tissue, are less and less easily affected, and if there be an excess of fibrous tissue the cells are not at all affected."

Abbe<sup>2</sup> reports two cases of intractable epithelial ulcers of the upper part of the helix of the ear cured by means of radium. In the one case the ulcer was one inch long by half an inch wide. In this case Abbe tested the comparative action of the X ray and radium. To this end during the half hour's treatment with radium the half of the diseased area was covered by a lead plate, and the reverse during the two minutes X ray treatment. Applications were made on alternate days, rapid healing taking place under both methods. The hard edges flattened, the ulcer filled up with pink granulations, and newly cicatrizing skin appeared at both edges. By the sixth treatment the radium was ahead in its efforts. After two more applications the X ray had caught up and gone ahead. The recovery was complete, and at time of report the patient remained well. The second detailed case after six applications, each an hour in duration, recovered. In both instances a French radium, 2 grains of 300,000 radio-activity, was used.

Of far greater interest is a case of giant cell sarcoma of lower jaw bone of two months standing. The growth replaced the substance of the bone except its lower border, from the middle line toward the left for an inch and a half. The vertical measurement was one inch, and it was also one inch thick. Two incisor teeth and the canine were very loosely embedded. On the inner aspect an ulcerating surface rose half way up on the teeth. The submaxillary lymphatics were felt in the neck. The case was a strictly

---

<sup>1</sup>London Lancet, April 16, 1904.

<sup>2</sup>N. Y. Med. Record, Aug. 27, 1904.

surgical one, and would have required a mutilating operation. The radium was applied to the soft mass growing inward on alternate days for one hour each. After four applications there was a marked change, the purple exuberant ulceration grew pink and small, the internal tumor mass shrinking simultaneously. After eight exposures the entire interior portion had flattened and become hard. Then the external area was exposed to the action of radium, and later because of the gain he had made, Abbe wisely decided to carry the sealed glass tube of radium into the tumor mass, despite the observed fact that radium tubes when sterilized and embedded either in muscle, cellular planes or peritoneum of an animal tends to become encapsulated and inert. This has been shown by repeated experimenters in France and Germany, and also by Abbe in the Laboratory of St. Luke's Hospital.

In making the preliminary incision, the knife sank into the mass by its own weight, and when withdrawn it was followed by a free flow of blood. The radium tube was thrust into the incision and left buried within the tumor for three hours. Upon removal a piece of borated gauze was laid over the spot for ten minutes. The treatment was repeated three times weekly for 15 times. Twice a long interval was allowed between exposures, because of inflammatory reaction. Subsequent examinations were made at new points, and upon making them a gritty feeling of ossification beginning in some places, and less hemorrhage were noted. The loose teeth became firmer and stood straighter. After eight weeks of treatment it was discontinued. Four months later there was retrograde shrinking of all the peripheral remnant of the original growth. The walls retracted to nearly a natural line and ossific changes have established themselves. The photographs of casts taken before and after show the very marked change which had taken place, but the giant cell element was still present, as demonstrated by section.

The well-known untoward action of radium upon germinating seeds and the growth of plants, as shown by many

experimenters, and also by Abbe, led the latter to make a microscopic study of the action of radium on malignant cells. In a case of mammary cancer, one week before the operation, the radium tube was placed for 12 hours upon the sound skin within the field of operation. On each of six days a different place was chosen, once over a secondary growth, and once it was thrust into the substance of the tumor where it was left for 24 hours. After amputation the entire series was submitted to careful pathological study. Complete superficial necrosis took place on healthy skin with evidences of deeper inflammation shown in leucocyte infiltration into the cellular tissue, and about all the vessels and nerves, with some thrombosis of the small vessels. There was a marked change in the superficial cancer area, showing dissolution and retrograde change in nests of cells near the radium, but less at a distance. Sections were made at right angles to the line of the tube where it was thrust into the tumor. A marked sphere of influence was uniformly shown for a quarter of an inch on all sides. Outside that limit the nests of carcinoma were unchanged, but within it there remained none but degenerated and disappearing cells. What would have been the effect had the pathological change gone on cannot be said in this instance, as the operation ended the retrograde changes which had been established. The giant cell sarcoma, which shrank to one-quarter the former size under radium, showed structure of malignancy still, but with fiber structure predominating. Microphotographs, casts, and models of these as well as other causes treated by Abbe form a part of the radium exhibit in the government building of the St. Louis Exposition. Abbe concludes that those malignant cells which have escaped destruction and retrograde change, show a striking quiescence, which may mean death of the vital force which makes them malignant. The author believes that on the theory referred to in Chapter VII. under the head of Physical Effects of Light, this would mean that the malignant cells which have lost their innervation and grown wildly have returned to more nearly their

proper atomic motion under the influence of the stimulus which has been imparted to them by the particles of the atoms of radium. It is not known what constitutes the malignancy of the cell, but the author believes that the explanation is to be found in a physical condition rather than

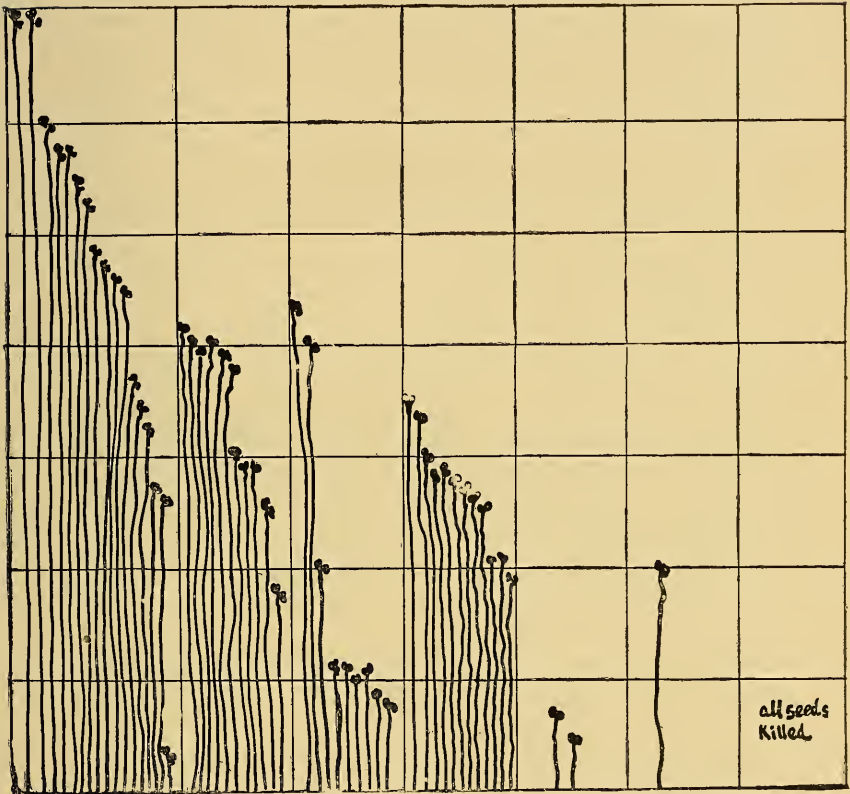

Fig. 49.—Diagrammatic representation of seed growth following exposure to radium rays; 20 seeds in each exposure; I., without exposure, 17 seeds grew; II., exposure for 2 days, 11 grew; III., 3 days, 9 grew; IV., 4 days, 12 grew; V., 5 days, 2 grew; VI., 6 days, 1 grew; VII., 10 days, none grew.

in that of a germ origin. It is in accord with much of observed fact, as to the effect of extreme stimulation in causing the destruction of some cells, and moderate stimulation a

regenerating effect upon others that they may be brought into the line of orderly growth again. In connection with the striking quiescence shown by malignant cells, Abbe states that one is reminded of the seeds which do not grow and the meal worms which are arrested in their development for an indefinitely long period. These experiments of Abbe's are notably scientific and convincing. They cannot but serve to stimulate careful clinical observation and experimental investigation. The need is for larger quantities of radium of greater radio-activity. In this connection there is introduced a diagrammatic cut showing the action of radium upon the development of germinating rape seed, for the use of which the author is indebted to the courtesy of Dr. Robert Abbe.

Radium in Malignant Diseases.—In September, 1903, the author in a paper on radium read before the American Electro-therapeutic Association, reported two inoperable and incurable cases in which treatment had been instituted by means of radium, one gramme of 7,000 radio-activity.

One, a case of sarcoma involving the left cheek, entire buccinator region and the mucous membrane of the lower left maxilla region, from the extreme angle of the jaw, extending upward and along the ramus of the jaw; the other, an inoperable primary pelvic case of epithelioma, involving the cervix, anterior and posterior vaginal walls; almost to the introitus, rectum, bladder and both broad ligaments. Both cases have been under treatment, the first for a month, the second for three months, by means of the X ray and ultra-violet light and both had been declared inoperable by the best surgical talent.

Similar cases, also two of cauliflower excrescence, all frankly inoperable, have been treated since. In every instance there has been an amelioration of the symptoms at first, i.e., control of pain, diminution of hemorrhage and discharge, lessened odor, lessened induration of affected parts, improved appearance of sore and a sense of well-being on the part of the patient.



During the year similar observations have frequently been made in the same class of cases, but the author wishes to assert in the most emphatic manner that there has been obtained no result which will warrant the belief for one moment that radium possesses any specific action in cancer. For a few weeks an improvement has invariably been noted, characterized by diminished pain, discharge, hemorrhage, odor and a sense of well-being. In some instances this has been marked. The symptomatic improvement is, however, evanescent. In a few weeks to one or two months the symptoms return with renewed vigor and the progress of the case is steadily downward, death ensuing from exhaustion.

The same is true of the X ray in these desperate inoperable pelvic or other internal cancers, and the author takes the occasion to say that every case of this character which she has had under care within the past three years has terminated fatally. Death has come as the result of the profound exhaustion just as it does naturally. That these patients have been made more comfortable for periods of time, greater or less, have experienced partial relief from the distressing syndrome, and that they have had greater length of days is admitted. The result obtained by Abbe in the case of giant cells sarcoma with a much higher radio-activity is encouraging. But despite the improvement the giant cell element remains.

While this is true, it does not follow that radium and for that matter other radio-active bodies are devoid of therapeutic value.

A case of rodent ulcer of eighteen years standing under care at this writing is doing so well that a favorable result is hoped for.

In a desperate epithelioma involving the loss of one eye and almost all of the nose, the patient had from three to four months of almost complete relief from pain and a sense of well-being foreign to her. But the story was just the same. After these months of relief of symptoms and apparent improvement in physical conditions, retrograde changes devel-

oped actively. Despite this, however, exposure to the radium rays always gave relief. The reaction became, however, very extreme toward the last of its use, evidenced by swelling and intense redness of the part and a sense of general malaise.

From the first, the author has observed the pain-relieving property of radium, a property held in common with electricity, suitably applied, light and the X ray. In the physical unity of the latter is to be found the explanation of the unity of physiological action and therapeutic result. The author stated a year since that from the physical properties and physiological effect of radium a therapeutic action was predicted. This is still true but not in such extensive malignant processes as reported.

During the past year two cases of anal fissure, the one had been referred for operation after months of classical treatment, but was unwilling to have it done, recovered completely in the course of about two weeks after beginning the use of the radium; the other of less long standing completely recovered in a week's time. The author has for a number of years established healing in these anal fissures by the use of rectal bipolar applications of alternating currents, the secondary of a magneto-induced, the sinusoidal or by the use of vacuum tube discharges, but the result was obtained in much less time by the use of the radium. From the ease and simplicity of its applications it lends itself to many conditions of this sort.

Holzkecht authorizes the statement that radium causes the disappearance of cutaneous telangiectases, obliterating the dilated vessels. The practicability of utilizing the effects of radiant activities for the relief of pathological conditions involving no such distressing syndrome nor lethal results as almost invariably mark the termination of malignant growths, should not for a moment be lost sight of. Radiant energy lends itself to the relief of many such conditions.

The hydro-oxid of thorium can be procured in large quantities at a moderate price, a sac of caoutchouc can be

filled with it and then placed over the diseased part. It may be a neuralgia, a recent sprain, a contusion, a superficial non-malignant skin lesion, an anal fissure, it matters not save that it must be remembered that thorium is very feebly radio-active as compared with radium, the latter being 1,000,000 times more active. Ulcerated areas may be bathed with a solution of chlorid of sodium before exposing them to the action of radium. It has been shown by Hardy and Wilcox that the decomposition of iodoform in a solution of chloroform is accelerated by certain substances such as the chlorid of sodium. To the phenomenon of oxidation the physiologic action may be attributed.

All sorts of rays acting on the surface are able to destroy diseased tissue, purely by co-operation with the oxygen of the air or with something else which is on the surface and which is not in the deep-seated parts. If, says Sir Oliver Lodge, there could be carried into the deeper structures whatever it is that co-operates at the surface by injection either of radium or of some oxidizing solution to co-operate with the X ray, the outlook would be more hopeful. As the gamma ray of radium is identical with the latter its penetrating power could be utilized under these suggested conditions instead of the X ray. When radium radiations enter the tissues nascent oxygen or ozone is generated. Interchemic action alters the function of the part, tissue reaction is increased and health restored.

Induced Radio-activity in Therapeutics.—This naturally leads up to the use of waters which have been rendered artificially radio-active. Such radio-active waters have been used by different medical men in different parts of the world, but no sufficient well-authenticated clinical evidence has been accumulated to give the method a place among therapeutic measures "of good and regular standing." Its supposed therapeutic value has been the subject of considerable sensational newspaper report. This is not denying the method the grain of truth which on physical ground it undoubtedly possesses. It will be recalled that radium emanations furnish a

spectrum hitherto unknown and that their transformation to helium follows their enclosure in a Geissler tube through which an electric current is discharged. The unknown always offers the hope of something not yet attained.

According to Soddy<sup>1</sup> all the emanations of radium are instantly evolved in gas "and mixed with the air above the solution. Now let these emanations be removed by a current of air passing through the solution. The air with the emanations can now be stored in a gas holder in another room. Observations will show that one-half of the emanations will disappear every four days, and in three weeks no emanations of radium will be left; but the solution from which it was obtained has grown a fresh crop of emanation just as fast as the old ones disappear. That is, it takes about three weeks for the solution of radium to be as potent as it was in the beginning when the salts of radium were first dropped into it."

For the treatment of respiratory conditions Soddy suggested that "for an inhaler, an ordinary gas wash bottle provided with two taps could be used, so that there is no leakage of these precious and slowly formed emanations. From five to ten milligrammes of dry radium bromid should be introduced into the wash bottle and a few drops of water drawn in to dissolve it, the taps being immediately closed. For the first treatment, the first few bubbles of gas should be inhaled with a deep breath, gradually increasing the dose. Repeat this treatment every day. In this manner the emanations of radium and their radio-activity, which is inimical to germ life, would do their work at the seat of the disease."

The only way to determine beyond question the place of radio-active substances and induced radio-activity in the therapeutic armamentarium of the physician is to lose sight completely of all their sensational elements and subject experimental and clinical evidence to the most exact and rigorous tests known to physicists and physicians.

---

<sup>1</sup>British Medical Journal.

Receptacles for the Therapeutic Uses of Radium.—The author has uniformly used the salt of radium in its enclosing glass or aluminum tube; rather than any of the receptacles for that purpose. With glass tubes the action of the  $\beta$  rays is limited. These identical with the cathode rays, it will be recalled, do not pass through glass but do through alumi-



Fig. 50.—Radium Receptacle for the Stomach.

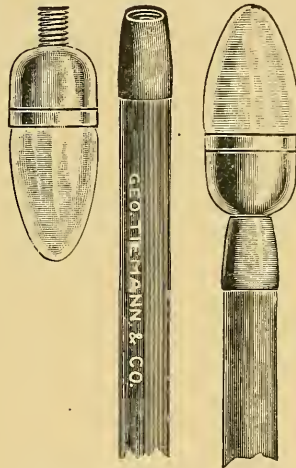

Fig. 51.—Radium Receptacle for the Oesophagus and Rectum.

num. Aluminum, on the other hand, limits the passage of the  $\alpha$  rays. In this connection the reader is referred to Rutherford's table on a previous page as to the thickness of aluminum transparent to the different rays. Again appropriate thickness of lead prevents the passage of the penetrating gamma rays just as with the X ray. Radium, unenclosed, exposed to moisture loses its radio-activity. The accompanying cuts, however, show several different applicators on the market for the use of radium. In Figs. 50 and 51 are

shown the devices of Dr. Max Einhorn<sup>1</sup> for use in the esophagus, stomach or rectum. Fig. 50 shows the enclosing capsule and radium tube for the stomach, while Fig. 51 shows the capsule and flexible bougie separately and attached for use in the rectum. There is no clinical evidence to show that radium used within the stomach has been of any practical value, however.

---

<sup>1</sup>N. Y. Med. Record, March 5, 1904.



Fig. 52.—1, brass containing receptacle for radium; 2, box for containing this receptacle when carried in pocket; 3 and 4, applicators of solid silver; 5, handle for the same; 6, applicator made of lead to which No. 3 can be attached.



Fig. 53.—This is the same as the preceding figure save that it is smaller and applicator No. 6 is omitted.

APPLICATOR SETS FOR THE EXTERNAL USE OF RADIUM.





## CHAPTER XX.

Fluorescence, Fluorescent Stimulation, Sensitization. Therapeutic Uses in Cancer, Lupus Vulgaris, Condylomata, Indurated Chancre and Malaria.

### Fluorescence and Fluorescent Stimulation.

Fluorescence.—In studying the phenomena observed by Herschel and Brewster, i.e., that some varieties of fluorspar, and also the solutions of certain substances, when looked at by transmitted light appeared colorless, but when viewed in reflected light presented a bluish appearance, Stokes discovered that under certain circumstances the rays of light are capable of undergoing refrangibility. He found that this phenomenon was characteristic of a large number of bodies, but from its having first been studied in fluorspar, he gave it the name of *fluorescence*.

“There can be no doubt that the property possessed by certain substances of appearing self-luminous, when exposed to the direct action of light rays, was a phenomenon known to the ancients. The discovery in tombs of ‘tear bottles,’ which are fluorescent to a remarkable degree, and the occasional reference to this peculiarity noticed in the works of Pliny, Albertus Magnus, and other writers of the Western School of Civilization, would be sufficient to substantiate such a claim even if more direct evidence were wanting. To the Oriental School of Philosophy the honor belongs of having initiated the first philosophic, if not truly scientific, research into this subject. So accurate are many of their observations that, stripped of the superfluous and tawdry tinsel with which Eastern mysticism and religious

superstition loves to cloak its discoveries, the facts recorded in the fourth book of the 'Talboth Rayoal' could well pass as an exposition of the present position of modern knowledge of the subject. A liberal acquaintance with phenomena dependent on reflection, refraction, diffusion and absorption of luminous radiations, coupled with that of fluorescence, allowed them to imbue the uneducated mind of the public with a superstitious reverence for the occult powers of the teacher, and the necessity for a very strict observance of the ritual enjoined for the prevention and cure of diseases, which modern science has proved to be injuriously affected by ultra-violet radiations. In descending to more modern times we remark that Vincenzo-Casirolo, in 1602, records some observations of a similar phenomenon noticed in connection with Bologna phosphorus—an impure sulphid of barium obtained by calcining sulphate of baryta with gum and other resinous exudates. The discovery of Canton's phosphorus (calcium sulphid) and Homberge phosphorus (chlorid of calcium) stimulated further research in this direction, and much speculation as to its causes was indulged in. Muschenbroeck's discovery of a similar property in petrol and Häuy in flourspar were the next to attract attention; but it was not till the year 1852, when Stokes published his experimental researches on "Changes of Refrangibility of Light," that the true cause of the phenomenon, previously termed "epipolic dispersion," was arrived at. He also succeeded in demonstrating this property in many substances not popularly recognized as fluorescent, i.e., wood, horn, bone, leather, skin, the claws of animals, and the foliage of certain plants. Among the better known fluorescent substances—quinin bisulphate, esculin, petrol, tolché, gelsemin, fluorescin, turmeric (curcuma), the platino-cyanids and the salts of uranium may be mentioned. Platino-cyanids are potentially active only in the solid state; others, like the salts of uranium, are more fluorescent as solids than they are in solution; turmeric, on the other hand, fluoresces equally well under both conditions; while naphthalin red, esculin and

quinin are most active in solution. The fluorescence of some substances only appears when they are suspended in an acid solution, others when dissolved in an alkaline medium. The transmutation of the more refrangible rays, effected by turmeric, explains its daily use by the Hindus to protect the skin against the ardent suns of the Tropics. Its use is also enjoined in the 'Talbath Rayoal' for a host of eruptive cuticular affections attributable to or aggravated by exposure to the ultra-violet radiations."<sup>1</sup>

Fluorescence Depends upon Absorption of Energy at One Wave Length and Emission at a Greater Wave Length.—The phenomenon of fluorescence depends upon the ability of some substances to absorb energy of radiation at one length, and to emit it as a radiation at a greater wave length, or, in other words, to have set up in their heavier molecules slower vibrations. This absorption does not occur at all parts of the spectrum, but may be in several parts, generally contiguous to one another. It may take place at the one end or the other of the spectrum. From the chemical end the ultra-violet frequencies are absorbed by the atmosphere or glass, while at the other end red is absorbed by alum, for example. The energy of radiation which the fluorescent substance emits is not monochromatic, nor is it of all wave lengths like white. For example, light waves are absorbed by the body, to be emitted as heat rays. Similarly the very quick and short frequencies or ultra-violet rays may be converted into slow visible rays. This absorption and emission is distinctly selective. The phenomenon of fluorescence is also dependent upon temperature. It was proven mathematically by Kirchhoff<sup>2</sup> that for every ray of light the relationship between the emissive and absorptive powers of all bodies is alike at uniform temperatures. It was this fact that led to the investigation of the chemical composition of the sun and its atmosphere. The spectra of absorbed light shows only lines or bands, but emission spectra may be unbroken in lines

---

<sup>1</sup>Medical Electrology and Radiology. Editorial, April, 1904.

<sup>2</sup>Spectrum Analysis, Landauer.

or bands. The immediate emission of absorbed light is characteristic of fluorescent substances. If they retain their luminosity, due to absorption of energy of radiation of a given wave length, the phenomenon is known as phosphorescence. Becquerel proved that all solid fluorescent substances were also phosphorescent, but only for a short time. This was done by means of an ingenious device, to which he gave the name of phosphroscope. If the absorbed light is retained long enough to remove the fluorescent body to a dark closet, the phosphorescence can be observed by viewing it after closing the eye for a few minutes. Some substances emit their light so quickly, however, that the only way in which to demonstrate that they still retain absorbed light is to use a phosphroscope, by means of which the observation can be made immediately. In this manner, the phosphorescence of substances before unsuspected of presenting the phenomenon, as iceland spar, for example, was established. Fluorescent substances or bodies are self-luminous throughout the period of their illumination. The color of the light emitted by them is not that of the energy of radiation or wave length absorbed, nor is it the same as the color of the substance itself, but of the color of the wave length emitted. It may be blue, green or red, as will be seen subsequently. In other words, a fluorescent substance is to be looked upon as a Radiant Frequency Transformer. Fluorescence is usually due to the absorption of that energy of radiation characterized by short wave length, as the ultra-violet. The light produced in the fluorescent substance may be of longer wave length than in the exciting light, but, as a rule, is never of shorter than the exciting energy of radiation. Eosin, fluorescin and naphthalin red are not governed by the same law, and the fluorescent light from these substances can contain shorter frequencies than the light absorbed. The color of fluorescent bodies depends upon absorbed light, while the color of objects ordinarily is due to reflected light. In phosphorescent substances the emission of light may assume different colors, as, for example, in sulphid of cal-

cium and sulphid of strontium. Absorbed light is capable of producing chemical effects, decomposition, for example, and upon this physical fact photography is based. Absorbed light may also, under certain conditions, produce mechanical results. This is beautifully shown in Crookes radiometer, described in Chapter II.

In the mineral kingdom silicate of zinc, commonly known as willemite, acts as a radiant energy transformer, fluorescing under the influence of ultra-violet rays, Roentgen and Becquerel rays, and also under the influence of vacuum tube discharges. This substance has been in common use among physicians to a greater or less extent since the discovery of Roentgen, and especially since the more common use of ultra-violet light, for the purpose of testing vacuum tube discharges from a source of high frequency and high potential. It functions as a radiant frequency transformer under these influences. This has led to the erroneous idea that in vacuum tubes the physician has a source rich in ultra-violet light. Such is not the case, however, and the phenomenon is due to the high frequency discharge, as shown in the chapter devoted to Vacuum Tube Discharges. The fact of its so functioning indicates the near kinship of light and high frequency currents.

Electrical and luminous vibrations do not differ physically other than by the frequency and wave length. The work of Tesla, supplemented as it has been by many other brilliant experimenters, resolves itself simply into raising the frequency of an alternating current until the rate is equal to the velocity of light without heat. Currents of high frequency and high potential, by reason of their physical laws and physiological action, stand in close relation to light energy, without which light would not exist. The light of the aurora is very rich in rays of light refrangibility, as are also sources of high frequency and high potential currents.

Fluorescence of Quinin and Other Substances.—When a beam of the sun's rays is focused, by means of a long focus quartz lens upon a solution of quinin sulphate con-

tained in a test tube or a glass trough, a beautiful cerulean cone of light is formed. This is much the brightest on the surface, diminishing in intensity as the light beam penetrates the liquid. This fluorescence is due to the absorption of certain rays. But when rays of light have passed through a sufficient thickness of a fluorescent substance they lose thereby the power of exciting fluorescence when they are passed through a second layer of the same substance.

This can be easily demonstrated by taking a test tube containing the solution of quinin and placing it in another and larger test tube of the same solution, or within a glass trough containing the solution. In the first instance, the fluid is brightly luminous or fluorescent upon exposure to the sun's rays or an arc light, but when immersed in a second tube containing the solution of quinin there is no fluorescence upon exposure to the source of light. This also results from a comparison of the absorption spectrum of a fluorescent substance with the appearance presented by this substance when the spectrum falls on it. Fluorescence indicates the beginning of absorption, and when it is most marked there is indicated a maximum of absorption. When quinin solution is placed in glass troughs with parallel sides, the phenomenon is seen upon placing it in different parts of the solar spectrum. There is no change observed in the less refrangible parts of the spectrum, but (see colored plate) from a point about half way between the lines G and H to some distance beyond the extreme range of the violet, rays of a beautiful sky blue color are seen to proceed. The impregnation of a paper with a solution of *æsculin* causes the invisible ultra-violet frequencies to become visible, likewise an alcoholic solution of *stramonium*, and canary glass, which is colored by means of a salt of uranium. Paper impregnated with barium platino-manganid and exposed to the light fluoresces with a beautiful green color. Here the absorbed light is emitted at a longer wave length than with quinin. Fluorescin in soda requires but a few drops to a large beaker of water exposed to the sun's rays or an arc

light, to produce beautiful fluorescent clouds of a green color, and upon agitation shows the fluorescent coloring throughout the whole vessel. These phenomena are produced by a diminution in the refrangibility of the frequencies outside of or beyond the violet, which are ordinarily too refrangible to affect the eye. Many of the more refrangible rays are cut off by means of glass, none of the ultra-violet frequencies of less than 30 micro-centimetres passing. Quartz, however, is much more transparent, and permits the passage of higher and shorter frequencies than 30 microcentimetres. By closing an aperture in a dark room with blue glass, and permitting the light to fall upon a piece of canary glass, which, as has been shown, is a fluorescent substance, it instantly appears self-luminous by reason of the emission of the energy of radiation, which it has absorbed, but at altered wave lengths. If a freshly prepared solution of chlorophyll in ether is poured into a test tube half filled with a solution of quinin sulphate, the two colors will appear green and colorless respectively in transmitted light, but blood red and sky blue in reflected light. By using a prism and trough formed of quartz, and receiving the spectrum on a sheet of paper, which has been washed with a solution of sulphate of quinin, two juxtaposed spectra may be seen. The spectrum on the part treated with the quinin sulphate will be seen to extend beyond the line H to an extent equal to that of the visible spectrum, and in it may be seen dark lines analogous to those in the ordinary spectrum known as Fraunhofer's lines, and indicating absorption. While the violet and the ultra-violet in most instances are the frequencies which undergo refrangibility, the phenomenon is not confined to them. A decoction of madder in alum, for example, gives yellow and violet light from about the line D to beyond the violet, and an alcoholic solution of chlorophyll gives red light from the line B to the limit of the spectrum. The more refrangible frequencies are produced in these instances by increased refrangibility of the yellow, green and blue frequencies. Magdala red forms an

exception to the rule, as a solution of it in a rectangular glass vessel upon exposure to a solar spectrum presents the phenomenon of an orange, red, yellow fluorescence, even in the red part of the spectrum. There are also some substances of no especial illuminating power, which present peculiar phenomena. Characters may be traced on paper with a solution of stramonium, for example. In daylight they are almost invisible, but upon illumination by the flame of burning sulphur or carbon bisulphid, become clearly visible instantaneously. Fluorescence is the most common of all the allied phenomena, i.e., phosphorescence, fluorescence, calorescence, investigated by Stokes, Leonard, Kundt, and others.

By fluorescence, then, there is understood the luminosity of substances exposed to the action of light, which lasts only as long as exposure to the light activities. It is an effect of absorbed light. The action which produces fluorescence in a quinin solution, for example, is due to the very short and high frequencies, but the emitted frequencies or fluorescent light are of the longer and slower frequencies, greater wave lengths than any of the absorbed frequencies, and by no chance none of the shorter wave length. The exceptions to this law have been referred to on a previous page.

Fluorescence, although not confined to them, is especially an attribute of ultra-violet rays, Roentgen and Becquerel rays. These are the vibrational activities which produce the most marked physiological action. The physiological action of these different rates of vibrational activity unquestionably has a common source. Their power to produce fluorescence, or to act as radiant frequency transformers, would seem to indicate this. As the phenomenon of fluorescence is produced by high frequency discharges, it would seem to have a place in the same category as the ultra-violet, Roentgen and Becquerel rays.

Fluorescence of the Blood and Lymph Serum.—The phenomenon of fluorescence is not confined to the mineral and vegetable kingdom, but is shared by the animal king-



dom as well. The fluorescence of the blood was demonstrated in 1866 by Dr. Henry Bence Jones.<sup>1</sup> He found during his investigations that the blood in all the organs of men and guinea pigs contained a fluorescent substance to which he gave the name of "animal quinioidin." In this fluorescence of the blood and the lymph serum in normal living tissue is to be found, the author believes, the keynote of the response of the living organism to the action of radiant energy. In this capacity of the human tissues, blood especially, to function as a radiant energy transformer, that is, to absorb light and emit it again, evidenced by its fluorescence, is found at least one conclusive reason for the physiological action of light.

Action of Fluorescent Illumination upon Infusoria.—The action of fluorescent light, obtained by the illumination of phenylacridin, on infusoria was tested by O. Raab, at the suggestion of H. von Tappeiner.<sup>2</sup> The subject of this experiment was *Paramœcium caudatum* in a suspended drop culture, placed in a damp chamber. But first, it had been shown that paramœcia, in an acridin solution, 1 in 20,000 die in sunlight in 6 minutes, and in diffused daylight about 60 minutes; but if kept in the dark, they were alive after 6,000 minutes, i.e., 100 hours. A 1 to 800 culture in an eosin solution, placed in the green part of the spectrum of an arc light, which was broken up by means of a prism, showed after from 2 to 4 hours' exposure all degrees of injury even to death. But little or no effect was produced upon the culture by the other parts of the spectrum, which are not absorbed by the eosin, at least but imperceptibly, and, therefore, do not produce fluorescence in it.

With a paramœcia culture in an acridin solution, 1 to 20,000, arranged so that all the light reaching it had to pass through a 4 to 5 cm. layer of concentrated acridin solution 1 to 500, the light no longer took effect, and the paramœcia

---

<sup>1</sup>Medical Times and Gazette, London, August, 1866, pp. 163-167.

<sup>2</sup>Muenchner Med. Wochenschr., 1900, No. 1, p. 5, and Zeitschrift 8. Biologie, Vol. XXXIX.

were healthy after a week, even when exposed to sunlight. Upon repeating the experiment, but taking a quinin solution as a screen instead of the acridin solution, the light acted disastrously as usual. This was due to the fact that the quinin absorbed the ultra-violet waves which, with the acridin, were inactive, the latter absorbing the violet rays only. The fluorescent light or emitted light with the quinin solution was active by reason of the more intense fluorescent stimulation, i.e., ultra-violet absorption and the emission of the frequencies of the blue region; or, in other words, the same frequencies as those absorbed by the acridin. When a solution of a fluorescent material, acridin, quinin, or whatever it may be, is placed within a solution of the same material, then the fluorescence of the first solution is either absent or much less marked because the first solution has absorbed the frequencies which, by reason of its physical nature, it is capable of absorbing before they reach the second solution, and as the fluorescent or emitted light is of a longer wave length, it follows that the fluorescent medium is not capable of absorbing it.

Von Tappeiner concludes from these experiments that it is not the fluorescent light which is harmful, but the process of stimulation induced by the fluorescence itself. The results of the experiments were summed up by von Tappeiner, as follows: "Light becomes highly injurious to paramœcia in the presence of acridin, phenylacridin, eosin, and quinin, in solutions which, of themselves in the dark, are little if at all poisonous."

It follows, therefore, that this action of light is very closely related to the ability of the substances mentioned to function as a radiant frequency transformer or to fluoresce.

The injury done is in the process of production of the fluorescence, as would be expected, for fluorescent substances do not function upon the withdrawal of the stimulus; or, if by chance, they emit light after the stimulus, i.e., exposure to an exciting source, light, the X ray or radium, it is of a phosphorescent nature which, as will be shown, has

no bactericidal action. According to Raab, the phenomena, i.e., the action of fluorescent stimulation upon the paramœcia caudatum, and upon chlorophyll, are the reverse of one another. In the former it results in the death of the paramœcia, while in the latter it is the condition of continued life.

The view is held by Tappeiner in common with the author, that this kind of light comes into play with those animal organs and fluids which have the capacity for fluorescence, as the skin, retina, aqueous and vitreous humors of the eye, blood and lymph serum. May they not, in other words, be regarded as radiant frequency transformers? In the absence of sunlight, it is impossible for them to function normally, hence disease and death. Or fluorescent substances may get into the body by way of food or drugs, which abnormally increase the fluorescent stimulation and cause an irritation of the skin. The skin inflammation from the use of buckwheat, both in man and beast, noticed by Wedding, von Tappeiner surmises is to be accounted for in this way, and to the author's mind it seems rational to conclude that there is a possible absorption or formation of fluorescent substances from the fodder.

The Action of Fluorescent Stimulation Analogous to the Action of Light Energy on Chlorophyll.—O. Raab believes that the action of fluorescent stimulation on infusoria finds its analogue in the action of light energy on the chlorophyll of plants, viz., that the light energy is converted into chemical energy. Chlorophyll is a fluorescent body, and in functioning as a radiant energy transformer the light energy is converted into chemical energy. The effect obtained from painting a diseased surface with a fluorescent substance, eosin, for example, would insure at the site of disease a greater stimulation than from the unabsorbed light energy alone, for under the stimulation of absorption there is also emission, evolving a much more intense light stimulation. Thus far this action of fluorescent substances has been regarded as a process of transformation. There is no ques-

tion but there is a more profound chemical action, than by the same frequencies of light energy unaided. Regarded as a process of transformation it does not seem essential that it should always be a step-up transformer. With eosin such is the case, however, and the higher degree of energy of radiation, the green, is converted into still higher, and in the process of giving birth, as it were, to other frequencies, shorter and higher than it absorbs, there is increased energy of action. To the author's mind this therapeutic use of fluorescent stimulation, or with some substances a sensitization, finds its analogue in the use of oxidizable metals at the anode when connected to a source of continuous E. M. F. Here the new-born or nascent salt of copper, for example, acts much more energetically than any preparation of copper which could be applied to the foci of disease.

Just so long as fluorescent substances are applied to diseased surfaces, or placed within mucous cavities, they unquestionably function as radiant frequency transformers, but when taken internally, and the body is exposed to the action of light, the X ray or radium, the problem is a different one. It seems reasonable, however, to suppose that fluorescent substances should function as radiant frequency transformers, and in so doing, impart healthful stimulation, if of themselves they are not injurious to the living organism, to certain diseased processes. That this is true of quinin in malaria, for example, is abundantly proven, and also that the normal fluorescence of the blood is absent in this disease.

This was a subject of most careful investigation by Drs. Rhoads and Pepper<sup>1</sup> over 30 years since. They found that the fluorescence of the blood in malaria was diminished, and that quinin acted to restore its fluorescence to the normal standard. With this increase of fluorescence, the fever disappeared and the patient got well.

The experiments of Rhoads and Pepper followed the discovery of Jones, and resulted in the presentation of 12 cases

---

<sup>1</sup>Penna. Hospital Reports for 1868, pp. 269, 280; also Phila. Med. Times, Jan. 23, 1875, p. 259, etc.

of ague, in which they demonstrated that quinin cured by increasing the fluorescence in the blood of fever patients. Dr. A. F. A. King, of Washington, unearthed the record of these experiments and cases in a comparatively recent article upon "Sunlight and Malaria,"<sup>1</sup> which will be considered especially under the head of Sensitization.

Action of Fluorescent Stimulation upon Ciliary Epithelium, etc.—Analogous observations to these of von Tappeiner have been made by M. R. Jacobson and M. Jodlbauer.<sup>2</sup> The experiments of the latter have been upon ciliary epithelium, as well as upon the peptonizing and saccharizing ferments and upon certain toxins. The untoward action of the fluorescent substances used, just as with von Tappeiner's experiments upon infusoria, were only manifested under the influence of light.

The conclusion naturally reached is that the phenomenon takes place only under the direct influence of fluorescence. Von Tappeiner and Jesionek found that of all the substances experimented with (acridin and its derivations, eosin, climolin, harmalin, uranin, magdala red), eosin presents the advantage of acting energetically at the same time upon cellular elements, toxins and ferments. They, therefore, selected it with which to make some experiments as to the therapeutic value of fluorescence.

Action of Fluorescent Stimulation in Lupus, Cancer and Syphilis.—Their experiments were instituted at the clinic for skin and specific disease (dermatological and syphilographical) of the faculty of medicine, Munich. The subjects selected were those having infectious dermatoses, lupus, cutaneous cancers and syphilitic lesions, and the experiments consisted in frequently painting the diseased parts with a 5 per cent. aqueous solution of eosin, and exposing them immediately to the rays of the sun, or, in bad weather,

---

<sup>1</sup>The American Journal of the Medical Sciences, Feb., 1902.

<sup>2</sup>Therapeutic experiments with fluorescent substances by von Tappeiner and Jesionek, *Semaine Medicale*, *Abst. in Revue Internationale Electrothérapie*, Jan., 1904.

to the light of an electric lamp. The lesions were protected during the night by a dressing of boric acid water, or a plaster of oxid of zinc ointment.

They noted that in three cases of cancer of the face under the influence of the treatment, the ulcerated surface became covered again with good granulations, the lesions evolving, as it were, toward a cure. In lupus, they found the action of this method so much the more energetic as the affected parts were the more accessible.

Superficial lupus patches, ulcerated or covered only with thin skin, were influenced by the treatment. The effect of medication was almost nil in deep-seated lupus nodules situated in the midst of healthy tissue. Equally good results were obtained in 10 cases of condylomata of the genitals in women, and in 2 cases of indurated chancre. In this report the frequency and time of the exposure of these various cases to fluorescent stimulation was not given by the authority quoted.<sup>1</sup>

Fluorescent Stimulation in Malignant Conditions, Hodgkin's Disease, etc.—Morton<sup>1</sup> has used fluorescent stimulation in the treatment of malignant conditions and Hodgkin's disease. He utilizes quinin, esculin, fluorescin, etc., in connection with (1) the Roentgen ray, and (2) radium. Quinin solutions fluoresce outside the body in acid solutions, esculin froxin, fluorescin, resorcin and eosin fluoresce in alkaline media. These substances are all capable of greater fluorescence when in a very dilute form, which renders their use innocuous. Because of the alkalinity of the blood esculin and other alkaline solutions would seem to be the better ones to use; but, on the other hand, experiments have shown that the ultimate products of quinin as formed in the excretions are still capable of fluorescence. Esculin passes through the organism without being decomposed. The addition of sodium chlorid increases its fluorescence. Because of the energy of radiation, blue and violet, which quinin and esculin

---

<sup>1</sup>N. Y. Med. and Philadelphia Med. Journal, Feb. 13 and 20, 1904.

emit, Morton has used them principally, the former in 5-grain doses, the latter in a dose of a grain, given in dilute solutions, preferably a few hours before treatment. Seven cases have been treated by Morton and under his advice. Five are reported recovered and two dead. One of Hodgkin's disease was under treatment for 5 months, and had 62 X ray exposures. He gained 14 pounds, and is considered recovered. Three primary breast carcinomas, one complicated by a recurrent carcinoma in the opposite breast, were similarly treated, and one reported cured to date. In one case 4 months only had elapsed since first treatment, in another 5, and in the third a year. In a case of rodent ulcer of the cheek, the size of a quarter-dollar, with continuous discharge and crusts, the ulcer healed over with a new skin in 18 days. The sixth case, extensive papillomatous growths in the abdomen, had been operated upon two months prior to coming under treatment. An ovarian tumor, the size of a derby hat, was found with abundant papillomatous growths attached to various parts of the abdominal peritoneum with much ascites. No attempt was made to remove the tumor, as the patient was very much emaciated, and death believed to be imminent. The patient was suffering extremely when treatment commenced March 21, 1903, from pain in the left side of the abdomen, paroxysmal, lasting several hours, and causing intense nausea. Urination was difficult, often recurring every half an hour, and the patient was very weak, unable to walk more than two blocks. Five to 10 grains of quinin bisulphate were administered daily, and exposures to the X ray hard tube, 20 minutes each, were made three times a week. In less than a month, the record reads, "not a pain or an ache," able to walk from 10 to 12 blocks without discomfort, to sleep all night, and no trouble whatever in micturition. On June 6 the surgeon opened the abdomen. He found that both ovaries had been the seat of papillomatous growths, and that these were more scattered over the peritoneum than he had first thought. He removed the primary tumors and hand-

fuls of the exuberant mass, along with quarts of bloody ascitic fluid. A 50 per cent. peroxid of hydrogen solution was used, followed by copious washings of saline solution. She made a beautiful recovery, resumed the X ray fluorescent treatment during the summer and autumn. Six months later had gained 35 pounds, felt strong and well; no consciousness of abdominal trouble. Morton believes that the violet and ultra-violet radiations within the abdominal cavity were the controlling factors in determining the patient's recovery.

### Sensitization.

It has been suggested that these substances act as transformers. The author is convinced in the light of recent studies and experimental work upon the part of a host of original investigators, that the better, and fully as illustrative a term, is that of "sensitization." The sensitized tissues are in truth made sensitive to rates of vibrational activity of oscillating light energy physically capable of greater penetration than those which act not dissimilarly upon normal or unsensitized tissues. By reason of this sensitization the action is not only much more energetic, but also much more deeply situated.

In the following pages are given the results of experimental work bearing upon sensitization (which has been referred to under the action of light energy upon bacteria), the conclusions of different investigators and also the hypothesis of S. G. Busck, of Finsen's Light Institute, as to the influence of daylight upon the action of quinin in weakening or destroying the malarial plasmodium.

It is very clearly shown by the mass of observed facts that it is the blue-violet and the ultra-violet which possess to a great extent bactericidal power, and the reason for the great difference between their action on the one hand and that of the longer, slower and less refrangible frequencies on the other, must undoubtedly be due to the absorbing



power of the former as against that of the latter, for the stronger the absorption the greater the fixation of energy and action. The manner of the transformation of the absorbed frequencies depends upon the periodicity of the swing of light corpuscles or rate of vibration. Corpuscular disturbances transmit energy from an active phase of matter to a passive or receiving non-vibrating phase. This transmitted energy in the case of the very rapid corpuscular disturbance of the short and high frequencies gives rise to a chemical process in the protoplasm of the bacteria, which causes their death; while transformation of the energy of those corpuscular disturbances of longer and slower frequency into heat or some other form of energy takes place, which under the given circumstances is carried off without harm to the bacteria.

The absorption of light as well as the mode of transformation depends not only on the physical nature of the frequency, i.e., its length, periodicity and amplitude, but also upon the properties of the substance by which it is absorbed.

By altering the properties of the substance, there will result a change in the action of light energy on said substances. It follows, therefore, that if in any way it is possible to alter the properties of the bacterial protoplasm, or perhaps only the surrounding culture medium, without thereby killing the organism, there would be established a condition by which it would be possible to obtain a different action from the usual one on the bacteria by the different frequencies of the spectrum. If this could be done for bacteria, it would be equally good for all living organisms, animal as well as plant life.

Sensitizers in Photography.—Vogel<sup>1</sup> in 1873 showed that by the addition of certain substances the so-called sensitizers to the ordinary photographic bromid-silver-gelatin plates, the latter can be made sensitive to rays or frequencies of the

---

<sup>1</sup>Quoted by Busck, *Lichtbiologie*.

spectrum, which before only had a very small action, or perhaps none at all; and he succeeded in producing plates, which were as readily influenced by red and yellow frequencies as by those of greater refrangibility. (color sensitive orthochromatic plates).

This discovery of Vogel has been extensively made use of in photography during the past thirty years, but no satisfactory explanation of the phenomenon has been found. It is not yet decided whether it depends on different conditions with regard to absorption or an alteration in the manner of transformation of the energy of the frequencies in question.

Certain biological phenomena have been considered analogous to photographic sensitization.

Among the fluorescent coloring substances there are several, of which chlorophyll is the most common, which are of very decided importance. These coloring substances are, according to Busck, to be considered as sensitizers analogous to that of Vogel, i.e., substances which only transmit the light energy to the coloring matter of the leaves, without themselves taking any direct part in the taking up of  $\text{CO}_2$ , or the giving off of oxygen.

In the 70's, Engelmann<sup>1</sup> drew a similar parallel, and he showed experimentally that the maximum activity with reference to the separation of oxygen is to be ascribed to certain frequencies according as the chlorophyll of the plant in question contains this or that coloring matter.

At the International Botanical Congress in St. Petersburg in 1884, the same thought was brought out by Timiriazeff,<sup>1</sup> who asserted that there was a perfect analogy between the significance of the chlorophyll with regard to the carbonic acid assimilation of plants and that of the colored sensitizers in the photographic process. According to the experiments of Becquerel, 1874, chlorophyll also possesses sensitizing action on photographic plates.

---

<sup>1</sup>Quoted by Busck, *Lichtbiologie*, Mitteilungen aus Finsen's Med. Lysinstitut in Kopenhagen, Heft VIII., 1904.

"In the pharmacological laboratory in München, Tappeiner<sup>1</sup> and his pupils, Raab,<sup>2</sup> Danielsohn,<sup>3</sup> Jacobsohn,<sup>4</sup> and Ullmann,<sup>5</sup> have undertaken during the last 5 years a series of extraordinarily interesting experiments with regard to the action of various fluorescent substances in light and darkness. Raab found that infusoria (*paramœcium caudatum*) even in very dilute acridin solution dried considerably sooner when standing in the light than in darkness, and sooner in direct sunlight than in diffuse daylight. The same was the case in experiments with other fluorescent solutions. Raab sums up his experiments as follows:

"(1) The action of daylight is very harmful in experiments with acridin, phosphin and eosin.

"(2) This depends on the production of fluorescence.

"(3) The most active rays are those which produce the greatest fluorescence.

"(4) It is evident that fluorescent substances have the power to transform the energy of the rays of light into living chemical energy.

"(5) It is evident that fluorescence also plays a part in the animal organism, though to a much less extent.

"In a later work Raab<sup>6</sup> says: Chinolin red and hæmatin solutions have the same action on *paramœcium caudatum* with regard to fluorescence as acridin and phosphin. The action of the non-fluorescent fuchsin and crystal violet solution on the other hand is not increased by light. He found further that sunlight had the power of causing localized necrosis (in the ears) of white mice, in whom previously eosin had been injected—a phenomena which he is inclined to consider as a burn in consequence of the great absorption of heat rays.

<sup>1</sup>Münchener Med. Wochenschr., 2 Jan., 1900, und 5 Nov., 1901.

<sup>2</sup>Zeitschr. f. Biologie 1900, Bd. XXXIX.

<sup>3</sup>Danielsohn, über die Einwirkung verschiedener Akridinderivate auf Infusorien, Diss., München, 1899.

<sup>4</sup>Zeitschr. f. Biologie, 1901, Bd. XLI.

<sup>5</sup>Ullmann über die Einwirkung elektrischen Bogenlichtes auf Mikro-organismen in Gegenwart von Fluoreszierenden Stoffen. Diss., München, 1901.

<sup>6</sup>Zeitschr. f. Biologie, 1902, Bd. XLIV.

Raab appears to see in these phenomena not only an action of light, but a highly poisonous activity brought out by the light from the different fluorescent substances. He remarks, however, that no increase in toxicity takes place in the fluid, when this is first exposed to light, and later, after the addition of paramœcia, placed in the dark. Contrary to this, Ledoux-Lebard<sup>1</sup> found that the active rays decompose the eosin and produce a substance that is poisonous to the paramœcia.

Jacobson<sup>2</sup> examined floating ciliated epithelium (from the pharynx of a frog) in various fluorescent fluids. The motion of the cilia ceased much sooner in the light than in darkness. A second experiment was made as follows: A subcutaneous injection of 2 cgm. of eosin in solution was made into a frog, which was kept in the dark 24 to 48 hours thereafter. Although the tissues of the frog were colored red, the ciliary motion was not affected. Jacobson thereafter prepared specimens of ciliated epithelial cells, and placed some in the dark and others in the light. In those standing in the light he noted the death of the ciliated epithelia after 3 hours, while those placed in the dark showed ciliary motion after 24 hours. After subcutaneous injections of 0.00015 pro gr. of body weight the frogs were seen to be strongly incited in direct sunlight. After 6 hours, paralysis of the hind legs occurred, and on the following day the animal was dead. After an injection of 0.0005 pro gr. of body weight local muscular paralyses were found after 2 hours, but heart action continued about 5 hours longer. Frogs injected with the same amount of eosin, but kept in the dark, did not show any signs of paralysis, and continued to live. Even doses of 0.002 pro gr. could be borne by the frogs without marked toxic symptoms when kept in the dark.

“By emptying the cavum cranii of frogs, and filling the cavity with paramœcium cultures, placing some of the speci-

---

<sup>1</sup>Annales de l'Institut Pasteur, 1902, No. 8.

<sup>2</sup>l. c.

mens in the dark and others in the light, Jacobson found that light, even after passing through a layer of animal tissue, had the power to kill the paramœcia.

“While Tappeiner<sup>1</sup> compares these phenomena with those of photographic sensitization, with which we are familiar, Jacobson<sup>2</sup> explains the toxic action quite differently. He writes :

“(1) Light increases the toxic action of fluorescent substances on ciliated epithelia.

“(2) The action of non-fluorescent poisonous substances is not increased by light.

“(3) Non-poisonous fluorescent substances exert the same action on ciliary motion in the light as in the dark.”

In discussing the influence of light energy upon bacteria, Chapter V., it will be recalled that this principle of sensitization was utilized by Dreyer, of Copenhagen, in Finsen's laboratory in a great variety of experiments. Dreyer regards the action of the substances mentioned as analogous to the sensitization of photographic plates. From his experiments Dreyer reached the conclusion that “by using certain sensitizers, micro-organisms and animal tissues may be made as sensitive, yes even more so, to the otherwise inert though relatively strongly penetrating yellow and greenish-yellow rays, as they normally are to the strongly active but slightly penetrating chemical rays.” As sensitizers, Dreyer<sup>3</sup> used especially erythrosin (tetra-iodo-fluoresceinatrium). This coloring matter extensively used in orthochromatic photography proved to be especially active in these experiments. These experiments are quoted in the chapter devoted to the influence of light energy upon bacteria. He used solutions of 1 : 5000 or 1 : 8000. As has been stated in considering the action of light energy upon sensitized bacteria Dreyer's experiments were extended to living organisms. By injecting erythrosin solution into the spinal cord of frogs, or by local

---

<sup>1</sup>Münchener Med. Wochenschr., Jan. 2, 1900.

<sup>2</sup>Quoted from Busck-Lichtbiologie.

<sup>3</sup>Mitteilungen aus Finsen's Med. Lichtinstitut, 1904, Heft VIII.

cutaneous injections in rabbits and men, he showed that the otherwise inactive frequencies of the spectrum may cause inflammatory phenomena in the same.

These phenomena of inflammation did not quite resemble, either macroscopically or microscopically, the characteristic light reaction, but they were plainly analogous. The differences seemed to depend on the depth to which the changes extended into the sensitized tissues, and to such an extent that thrombosis of the deeper vessels occurred. "If," says Busck, "this experimentation is correct, it would favor the theory which ascribes the above-mentioned phenomena to the direct action of light energy made possible by the presence of the substances in question; in other words, an analogy with the action of optical sensitizers on the silver haloids."

On the other hand, Jacobson,<sup>1</sup> among others, has declared his belief in favor of the more toxicological explanation. He considers the toxic action of the fluorescent substances as the determining factor, even though in some instances the toxicity may be so small as not to be noticed when the action of the light is removed.

Jacobson concludes that "poisonous fluorescent coloring matters are inactive," and this is based on experiments with only one substance, viz., esculin; while his study of poisonous, but non-fluorescent substances only embraces fuchsin. His experiments suggest, says Busck, an extended study of the subject, but they do not prove anything in regard to all other non-toxic or non-fluorescent bodies. Busck notes in this connection that some experiments which he undertook after the above was in print, gave the result that the Koch plate cultures of bacillus prodigiosus were sterilized about seven times as quickly in concentrated light that had passed through a filter of 5% potassium chromate, when the culture medium (agar) was colored with a dilute fuchsin solution 1:5000 as when uncolored. Busck concludes that the

---

<sup>1</sup>l. c.

question must for the present remain unanswered, whether death in the case is to be ascribed to the simultaneous occurrence of two injurious factors, the toxicity of the fuchsin and the bactericidal action of the greenish-yellow rays, or to the increased action of the light in consequence of the greater absorption. The author believes on physical, not experimental, grounds that the latter is the true explanation, and that it is possible, as suggested by Busck, that the difference between the two theories depends on the fact that "light reaction" and "toxicity" are not clearly defined. It is simply a fixation of radiant energy, but not of those frequencies which are so well known by their action upon silver bromid. Let there be placed suitable media in the path of radiant and oscillating energy, and it meets cessation, the waves do their work not in this instance the very short and high frequencies of oscillating light corpuscles upon particles of silver, but the longer and slower frequencies of oscillating light energy upon substances placed in their path capable of being acted upon by them, erythrosin, for example, which leave their record and come to rest. In this instance the record is that of a deep-seated inflammatory action upon the tissues placed in the path of the light energy. In this way the energy is stored, and "there is no higher achievement of human hands than the storage of energy."

Dryer formulates the following conclusions in regard to sensitization:

(1) The fluorescence is not the determining factor in sensitization, because there are substances which are strongly fluorescent, which, however, are only slightly sensitizing, or not at all so (esculin, fluorescin), and on the other hand, there are non-fluorescent substances which are capable of sensitizing (cyanin).

(2) Neither is the absorption the determining property, because there are fluorescent as well as non-fluorescent substances, which are very absorbent, which are, however, not sensitizing to the rays which they absorb.

(3) It is scarcely probable that the sensitizing depends

upon the formation of toxic products in the sensitizer during the exposure, which have a deleterious effect upon the micro-organisms and the animal tissues, because if a sensitizer, as, for instance, erythrosin, is first exposed to light for ten minutes, and thereafter immediately used as a sensitizer, its power in this direction will be greatly diminished. This is very clearly demonstrated by the following table:

Filter.	Time required to kill <i>Nassula</i> sensitized with	
	Erythrosin sol. (1:8000) not exposed to light.	Erythrosin sol. (1:8000) exposed to light.
Rock crystal .....	12 seconds	18 seconds
Clear glass .....	12 "	25 "
5% nickel sulphate .....	12 "	30 "
Blue glass .....	36 "	135 "
5% potassium chromate .....	12 "	30 "
5% potass. bi-chromate .....	12 "	70 "

It cannot be regarded simply as a coincidence that almost all the coloring substances which in the experiments referred to were found to be active were more or less fluorescent. It must be understood, therefore, from the first two points formulated by Dreyer, that neither the fluorescence nor the absorption alone is the determining factor. Both are evidently of importance. If the frequencies of oscillating light energy of the yellow and green regions of the spectrum were not absorbed they could not exert any deadly influence; or, in other words, they could not do any work. As it is the presence of the chlorophyll which facilitates the absorption of the energy, governing plant assimilation and disassimilation, so do these coloring substances facilitate the absorption of the strongly penetrating energy of the spectrum, determining thereby actual changes in the tissues. There are great numbers of photographic sensitizers which are non-fluorescent, nor does the fact that a coloring matter which possesses a profound sensitizing action on photographic silver haloids warrant taking it for granted that it may comport itself in the same fashion with living tissue for a sensitizer without further proof. It does not follow



even in photographic processes that the same substance shall in every instance act as a sensitizer. In one instance it may and another not, although the same substance often possesses both properties, besides there is a difference between optical and chemical sensitizers, just as there is between optical and chemical light intensity. It may be proven by further experimental work, whether in sensitizing living organisms, phenomena are not produced which though leading to similar results may be of an altogether different nature.

Tappeiner<sup>1</sup> extended his experiments with regard to sensitization into other provinces than those above mentioned. He showed that enzymes (papayotin, diastase, invertin) as well as toxins (rizan) were weakened by exposure to light, after the addition of certain fluorescent substances—as eosin or magdala red—while no noticeable change took place, if after the addition of the same substances they were kept in the dark.

The above-mentioned artistic sensitization is not only of great theoretical interest, but also has prospect of attaining an extensive practical importance, among other things, with regard to the therapy of light energy. Already in 1900 Tappeiner concluded his recital of the above-mentioned experiments with the following statement: “Conversely, by the incorporation or extraction of certain fluorescent substances, it may be possible, through the action of light, to obtain a therapeutically useful operation, so that then such substances may find a use, for instance, in dermatology, analogous to that of eosin and other fluorescent coloring matters which have been used empirically for the last 10 years as sensitizers in phototherapy.”

In the treatment of lupus vulgaris and epithelioma by means of light the attempt has already been made in Fin-  
sen's Institute, as well as in Munich, as the reader will see in subsequent pages, to increase the action by sensitizing the diseased tissues.

---

<sup>1</sup>Berichte d. d. chem. Gesellschaft 1903. Bd. XXXVI., S. 3035, and quoted by Busck.

Tappeiner at this time is disposed to reject the term "sensitization," as he considers the phenomena altogether dependent upon the action of phosphorescent light, and replaces it by the term "photodynamy." Busck does not think it necessary to reject so familiar and illustrative a term as "sensitization." He considers it necessary, however, to give it as wide a significance in biology as in photography, where the term sensitization is used as a general name for processes of widely differing nature.

In this connection it is pertinent to recall the observation of Wedding in regard to the action on the skin of light or parti-colored beasts fed on buckwheat, when exposed to the action of light, a condition which does not appear when they are kept in the dark. Spotted animals, it will be remembered, are only affected on the non-pigmented areas. This phenomenon is well known to farmers (and within the author's knowledge occurred also in human beings when living on buckwheat flour). Finsen refers to it in his treatise on the action of light on the course of smallpox, and says, "We see, therefore, that the skin can be brought into such a sensitive condition that even a very small, under ordinary circumstances absolutely unimportant amount of light, is able to call forth such important lesions."

This, as is stated in a previous page, is believed by von Tappeiner to be due to the absorption or formation of a fluorescent substance from the fodder. Busck did not regard it as proven that the buckwheat contained a substance capable of sensitizing the skin, i.e., rendering it sensitive to the rays that otherwise have no action upon it. As almost all biological sensitizers thus far known are fluorescent, Busck thought that even with buckwheat it must be a fluorescent coloring matter peculiar to it. An analysis of buckwheat was undertaken for him by Professor Kofold, the Director of the Pharmaceutical College in Copenhagen, yielding the positive result that the ordinary, and especially the silver buckwheat contained a fluorescent red coloring matter, not

found in the other grasses. This coloring matter, called by Professor Kofold "fluorphyll," is soluble in alcohol and ether, but not in water.<sup>1</sup>

Busck says, however, that the amount of fluorphyll thus far produced is too small to undertake any systematic experiments with regard to its sensitizing action. The few small tests which he made with but half a gram of the substance gave negative results. Because of the insolubility of the substance in water these experiments were rendered the more difficult. It is, therefore, not yet proven, he concludes, that the buckwheat exanthem is to be ascribed to the action of light on the sensitized skin; but the fact that buckwheat contains a fluorescent substance not found in other fodder evidences the correctness of the hypothesis. Suffice it to say that whatever the results of future experiments may be in this special direction, Busck considers, as does the author, that such a characteristic process so effective in its action as sensitizing must play a more important part than formerly was supposed, and that many seemingly quite different biological and pathological phenomena will find their explanation herein. Finsen takes it for granted that the peculiar sensitiveness of the skin of smallpox patients to light, a sensitiveness which he, as already mentioned, classed together with that of buckwheat exanthem, possibly can be explained along the same lines.

The investigations of Tappeiner and his pupil during the past five years upon the poisonous effects of various fluorescent fluids in light and darkness, show that the destructive effect of the substances in question, for example, upon infusoriæ, is enormously increased by the effect of light. Even when these liquids are so much diluted that in the dark they have no apparent detrimental effect upon the infusoriæ, the latter, nevertheless, will be speedily destroyed in such solutions if they are placed in the sunlight or in diffuse daylight.

---

<sup>1</sup>A description of this substance and the mode of obtaining it will be found in *Mitteilungen aus Finsen's Med. Lichtinstitut*, Heft IX.

which under normal conditions would not lower their vitality. The frequencies which are the most effective in this respect are those which produce fluorescence in the liquids in question. These experiments of Tappeiner were made the subject of a study by G. Busck,<sup>1</sup> who points out that the discovery of these phenomena happened during the same experiments with the toxicity of various preparations derived from quinin, and that the quinin preparations possess such sensitizing (sensitiveness-arousing) qualities.

The fact that frequencies otherwise fairly inactive proved themselves strongly microbicidal with regard to sensitized micro-organisms, led him to look for the power of these preparations to make the plasmodia sensitive, so that the latter are destroyed or weakened under the influence of daylight.

He bases his supposition upon the following established facts, pointing out in the same connection how simply and readily his hypothesis can be proved, viz., by exposing the quinin-saturated patient to the action of daylight or electric arc baths, preferably, however, to a source of light energy rich in the blue-violet frequencies.

In 1902 Dr. A. A. King<sup>2</sup> suggested that the treatment of malarial patients be carried on in the dark because many clinical and epidemic characteristics of this disease could be explained by the supposition that the sporulation of the malarial plasmodia could not take place in the dark, only in the light, and especially in the red light. He, therefore, recommended that patients should be kept in the dark or in rooms with purple or violet stained windows. This would constitute a negative phototherapy, as in the Finsen red light treatment of smallpox, i.e., the object being to cut out certain frequencies, rather than to have the action of those remaining. Although King held the opinion that the curative action of quinin bore a relation to its fluorescent proper-

---

<sup>1</sup>Mitteilungen aus Finsen's Medicinische Lysinstitut, 1904, Heft VIII.

<sup>2</sup>The American Journal of the Medical Sciences, Feb., 1902.

ties, he still persisted in his idea that it was the exclusion of all the frequencies most intensely active chemically which facilitated the treatment of malaria. His arguments were both ingenious and interesting, his conclusions, however, in the light of physical laws and recent biological experiment, the author believes, are wrongly drawn. In support of his theory King draws the conclusion that red light promotes the vital processes of the amœba, while violet light retards them; and as the plasmodium malariae is a naked amœba he infers that the same thing applies to the latter. As a basis for the correctness of his hypothesis he took the experimental investigations of Harrington and Leaming,<sup>1</sup> which were referred to on a previous page. That part of their experiments which is of interest in this connection is summed up by the following points:

1. Amœba streams in the presence of red light.
2. Streaming is retarded, stopped or reversed by rays from the violet end of the spectrum.
3. Further, the effectiveness of the following kinds of light as inhibitors of protoplasmic flow, diminishes in the order named: white, violet, red.

The inference drawn by King that the vital processes of the amœba are retarded by the violet and promoted by the red does not seem in accord with the observed facts, for it is distinctly pointed out by Harrington and Leaming that the streaming of the protoplasm in the amœba is again continued after remaining a few minutes in any quality of light indicating that the point is the sudden change of light. In the detailed account of their experimental work nothing is said about the intensity of the light employed. So far as may be judged, however, it was evidently comparatively weak. The experiments seem to point to the fact that a transitory vigor is produced by the sudden change from a light of longer and slower wave length and less refrangibility to one of the shorter, higher and more refrangible rays.

---

<sup>1</sup>The Reactions of Lights of Different Colors. The American Journal of Physiology, August, 1899, No. 1, Vol. III.

from a less intense to a more intense light. Busck<sup>1</sup> in a study of King's hypothesis, states that the assumption that the inciting effect of the red frequencies, as shown by one experiment of Harrington and Leaming, is not supported by those which Dreyer has carried out at the Finsen Laboratory. Harrington and Leaming observed that a sudden change from darkness to red light brought about the movements in ten seconds, but in this experiment the possibility of a heating effect from the light energy was not precluded.

Dreyer<sup>2</sup> found that the blue-violet frequencies have an inciting, and in the powerful concentration, a destructive effect, while the amœbæ in the red light remain in about the same condition as in the dark.

Verworn<sup>3</sup> and Davenport<sup>4</sup> do not find the amœba proteus at all phototactic. The latter, however, finds that the amœba showed itself negatively phototactic to light of an intensity varying from strong diffuse daylight to direct sunlight.

Busck concludes that in these observations of Harrington and Leaming there is to be found no support for King's supposition that the plasmodium malarie requires red light in order that its sporulation may be brought about.

"I. King first opposes the supposition which has hitherto been generally accepted, that the warmth of the sun, such as influences the frequency of cases of malaria, independent of the fact that a certain degree of warmth is, of course, necessary in order that the infection-carrying mosquitoes can live and preserve their activity; in this connection he refers to statements by various writers, and mentions, among other things, that negroes, whose dark skins in a particularly high degree absorb the heat rays of sunlight, possess relative immunity from malaria. When, all the same, there exists a correlation between intermittent fever and warm climates

---

<sup>1</sup>The Journal of the American Medical Sciences, July, 1904.

<sup>2</sup>G. Dreyer, *Lysets Indvirkning paa Amøber Nuddelelser fra Finsen's medicinske Lysinstitut*, 1903, Vol. V.

<sup>3</sup>M. Verworn, *Psycho-Physiologische Protisten-studien*, 1889.

<sup>4</sup>C. B. Davenport, *Experimental Morphology*, 1897.

or seasons, we must, according to King, look for the cause not in the warmth of the sun, but in the light of the sun upon which depends the sporulation of the plasmodia.

“All the conditions upon which the supposition was previously based, that warmth is an important factor in calling forth intermittent fever, may, with the same right, be held to be in favor of the view that sunlight plays a part as an etiological factor. When King, however, points out that the inhabitants of the island of Tahiti, according to Quatrefages, are free from swamp fever, although the island is only 18 degrees removed from the equator, and holds that this fact speaks against the theory of warmth being of importance, the same example may just as well be taken as a proof that neither can sunlight be the decisive factor. A more likely supposition, it seems to me, is that the conditions and nature of the soil are unfavorable for the development of anopheles, in the same way as Denmark, for instance, has gradually become so by the reclaiming of swampy land by drainage, etc.

“2. Febrile paroxysms appear, as a rule, in the daytime, and only in exceptional cases during the night. Even if febrile attacks at night occur somewhat more frequently than King supposes, it can hardly be denied that they occur with predominant frequency in the daytime, and this circumstance really does seem to speak in favor of daylight in some way or other being able to influence plasmodium malarie; but as long as we have no accurate knowledge of the duration of the sporulation process of the plasmodia, the above fact does not tell us anything definite as to whether this effect of light is favorable or the opposite.

“3. The fact that negroes are less frequently attacked by malaria than human beings of the white race, King attributes to the dark color of their skin, which hinders the light from exercising its sporulation-inciting influence upon the plasmodia in the blood. Even if it is not out of the question that the relative immunity of the negroes may be due to entirely different causes, it must be admitted that

King has a good argument in favor of the correctness of his hypothesis, there is, however, every reason to accentuate, as Chappel does, that the clothing of civilized nations as a protection against daylight may, in many cases, to some extent, be taken as an equivalent to the dark, but often uncovered skin of the negroes.

"4. King next quotes a number of writers, according to whom the frequency of cases of illness in malarial districts decreases during periods of much rain or mists, and he connects this decrease with the lesser intensity of daylight at such periods. I must confess it seems to me more natural to explain this by the supposition that rain and mist diminish the chances of being infected by the stings of anopheles.

"5. King, after having drawn attention to various examples of spontaneous cure of malaria, and suggested that the patients in question had perhaps been treated in especially dark hospital rooms, puts forward the following hypothesis: The red corpuscles in which the plasmodia live gradually increase in size, so that some of them are at length retained in the capillaries of the skin, where sporulation is then brought about under the influence of daylight. The fever paroxysm which accompanies the process is followed by the sweating stage, during which the blood vessels of the skin are dilated, whereby the blood corpuscles therein retained are replaced, and the new generation of plasmodia is distributed to the other organs of the body.

"King looks for the potent principle of those medicines which have been used successfully against malaria in their ability to alter the optical peculiarities of the blood; some of them (Prussian blue, methylene blue) so color the blood that the rays of red light are kept away from the plasmodia, while others (quinin, esculin, fraxin) have the peculiarity in common of being fluorescent, and thereby *accentuating* the violet rays of the spectrum in the blood! According to some investigations, now more than 30 years



old, by Jones, Rhoads and Pepper,<sup>1</sup> the blood and most of the tissues in human beings and animals are slightly fluorescent; in malarial patients this fluorescence is considerably reduced, while it again increases by the taking of quinin. King sees in this proof that the healing effect of quinin upon malaria is due to its fluorescence; he seems, however, to attach more importance to the beneficial effect of red rays upon the plasmodia than to the detrimental effect of violet rays, and he recommends the following treatment of malaria: "Keep malarial patients in dark rooms or in rooms with violet or purple windows; clothe them with garments impenetrable to light. Give the patients such remedies as render the blood dark or violet or lessen its translucency."

It is known in this disease that the blood loses its power to functionate as a radiant frequency transformer, and that the remedy for that disease is to be found in a substance which, under exposure to ultra-violet light or the higher of the visible chemical frequencies of the spectrum, absorbs the higher energy of radiation, and emits it at the lower, but still within the chemical frequencies of the spectrum. This is shown by the characteristic coloring, blue, of a solution of quinin sulphate when exposed to the chemical frequencies of light.

Quinin and several of its derivatives have been shown to have sensitizing properties as well as the phenomenon of fluorescence. These cinchona preparations exert a specific action on malaria, an action which can scarcely be explained on the ground of its toxic effect on the malarial plasmodium alone, although, according to the investigations made into its nature and mode of action, this is evidently of great importance. The question is asked by Busck, who has given the latter some considerable attention, whether it is not probable that the sensitizing properties of the quinin preparations bear a relation to the therapeutic effect. In the fact that the "specific" action of quinin is not understood, he finds

---

<sup>1</sup>Referred to by the author previously.

a reason for not leaving any of these peculiarities of condition out of consideration, and at least so well a marked one as their sensitizing power when seeking for an explanation.

Busck suggests that an inquiry as to whether daylight does not contribute at least somewhat to the successful results of the quinin treatment by killing, or at least weakening, the sensitized malarial plasmodium would be in order.

He bases his views, which are also entertained by others, upon the following facts:

(1) Quinin is fluorescent even in extreme dilutions, 1—1,000,000 and its sensitizing power is demonstrated among others by Ullmann's experiments, which show that paramœcia placed in a quinin solution 1/20000 did not die until after 5 hours when standing in the dark, while they were already killed inside of 8 minutes when he placed them in the sunlight under conditions which otherwise could not have exerted any harmful influence on paramœcia.

(2) According to Jacobson's and Dreyer's experiments light is able to exert its bactericidal action on the sensitized organism, even after passing through a layer of animal tissue. The depth to which it is able to exert this action depends, of course, among other things on the intensity of the light.

(3) The tissue elements of the human body are pellucid, and even if only a comparatively small portion of the body surface is exposed to light, the blood, and with it also the plasmodia, on account of the constant circulation, may be exposed to the influence of the light.

Busck concludes that should these hypotheses be correct, which can be readily determined by clinical examination of patients treated with quinin in light and darkness, sun baths or electric light baths would seem to be indicated in connection with the quinin treatment of malarial patients. It is interesting to note in this connection that there appeared in the current medical literature of the day, several years since, the statement that an Italian physician administered quinin to

his malarial patients, and then exposed them to the action of blue light in a room in which the ordinary clear glass was replaced by blue glass. Upon reading the report the method was practised by a physician living in Illinois upon his malarial patients, with what he felt was an unusual degree of success in the management of the same class of patients. The same medication, i.e., calomel and quinin, was exhibited as when no such exposure to the visible chemical energy of the spectrum was made. According to this physician,<sup>1</sup> better and more prompt results were obtained than with the classic method.

This method of sensitization has been used quite extensively by Dr. William James Morton in malignant diseases. He has utilized fluorescent substances, and especially quinin, in these cases, rendering the organism sensitive to other forms of radiating energy than the different frequencies of the spectrum, viz., the Roentgen<sup>2</sup> ray and radium. In the critical analysis given of the cases reported, the author is not convinced that a better showing is made from thus sensitizing the tissues before exposing them to the influence of the Roentgen or radium rays. In the average of these cases it must be borne in mind that, as a rule, they dealt with frankly incurable disease.

Busck and Dr. Siim have undertaken a number of experiments which are not yet quite finished, but which in view of the thoroughly careful and scientific work carried on at the Finsen Light Institute, at Copenhagen, cannot fail to be prolific in results for or against the theory.<sup>3</sup> As yet they have not yielded any positive results.

---

<sup>1</sup>Personal communication—in changing his office the journal containing the original reference was lost, therefore the name of the Italian physician is not given, but the author surmises that it is the same as the one referred to in the concluding paragraph of this chapter.

<sup>2</sup>It has been suggested that X rays passing through glass may by a species of fluorescence give rise to new ultra-violet rays.

<sup>3</sup>The beneficent action of the Danish Government in endowing the light institute of Finsen at Copenhagen cannot be too heartily commended, and the author cannot but voice the hope that the Com-

T. Catteneo, who was much impressed by d'Abbadies, remarks upon the effects of sulphur mines on paludism and some observations published about the same time, on the immunity of earth eaters from miasmatic disease conceived the possibility of combining the administration of the sulphates and fluorescent salts of quinin with exposure to light as a cure for malaria.<sup>1</sup>

Fluorescent Transillumination.—Fluorescent substances may be administered in suitable doses, and the patient then exposed to (1) sunlight, (2) incandescent light, (3) arc light, (4) Roentgen ray, and (5) radium for the purpose of utilizing the substance or drug to secure (1) more efficient transillumination of the tissue for diagnostic purposes (Kemp); (2) as a therapeutic measure (Busck, an Italian physician (Catteneo), and Morton). In both instances the substance used receives energy of radiation of the shortest wave length, for, as a rule, it is the violet and ultra-violet rays which undergo an alteration of refrangibility, and emits them at a longer wave length. In the case of fluorescein used by Kemp for purposes of transilluminating the stomach, the visible chemical frequencies emitted by the incandescent stomach lamp are absorbed by the fluorescein and given off at the frequencies just below, or those frequencies which in the spectrum are known by the color of green. This green fluorescence enables a much more clear and thorough investigation of the stomach outlines and conditions than simple transillumination by means of light. Its use is suggested by Kemp in cystoscopy, and it should be of value to the genito-urinary specialist.

By the use of the water-cooled vaginal lamp used for the treatment of a variety of gynæcological conditions, fluor-

---

monwealth of the paternal government or that of the states may see their way to a similar action.

The workers are ready, but amidst the perplexities and cares of the physician's daily life, with its never-ending problem of the where-with, it is impossible to enter into the harvest which awaits the intelligent investigator.

<sup>1</sup>Med. Electrology and Radiology, April, 1904, Editorial.

escent substances in solution can at will be substituted for the water, and by closing the outflow tube of the obturator be kept within the vagina. In this way any value that the transillumination might have in diagnosis can be made use of, and at the same time the therapeutic effect of the radiant frequency transformer may be utilized. Theoretically, the method should be of value in the treatment of gonorrhœa involving the vagina, uterus, tubes even as well as the bladder, both in men and women. The method is simple enough. The fluorescence insures light, and the gonococcus, a lover of darkness, may be obliged to yield its vantage ground. The destruction of the gonococcus might take place outside of the body, or in an accessible mucous cavity. If such a bactericidal influence were exerted in the living tissue, the author believes it would be the same action as that of the short high frequencies or ultra-violet light on bacteria, an inhibiting action, for, as stated, ultra-violet frequencies act upon bacteria by reason of their short length and great frequency to shake them up, agitate them, compel them to give up little by little their energy until they are ready to cry quits. At the same time physiologic resistance is increased by their action on the blood.

Bacterial and Therapeutic Action of Phosphorescent Light.—Freund regarded it as permissible to connect the observation of Becquerel that phosphorescent plates make the infra-red frequencies visible, with certain effects of the red end of the spectrum on normal tissues. As it is proven that certain tissues are capable of fluorescence, and that the process of inducing fluorescence produces changes in the tissues, he felt all the more that this connection was admissible.

A continuous spectrum extending into the blue is given in general by the rays of phosphorescent light. The color of the radiated light is independent of the color of the exciting rays; that is, a certain luminous substance will always give off the same light whether the exciting light be blue or violet or white.

Owing to the suggestion of Becquerel and other phy-

sicists, that phosphorescent bodies under suitable experimental conditions might be made to emit direct rays capable of acting on the photographic plate after passing through opaque bodies, and in consequence to exercise the same kind of action as the Roentgen rays, Freund was induced to make some experiments with a view of testing the possible biological effect of phosphorescent light. These experiments were carried out with great care, but gave absolutely negative results. They were made upon a diffuse culture of *staphylococcus pyogenes aureus*, and upon a typhus culture. He concluded, therefore, that phosphorescent light of the intensity available for these experiments has no influence on bacterial growths. In the same connection he reports that C. Roth had employed the light radiated by phosphorescent bodies in various affections of the cavities and passages of the body, and that, according to his account, he had obtained favorable results in cases of chronic nasal catarrh. This Freund justly concludes could not be due, as Roth seemed inclined to believe, to a deleterious action of phosphorescent light on bacteria.

## CHAPTER XXI.

The Pernicious Effect of Sunlight; Insolation. Pathological Effects of Electric Lighting.

### Action of Light Energy Upon Super-sensitive Skins.

The Pernicious Effects of Sunlight upon the Normal Skin.—Under the influence of light there appears upon the skin of the higher animals certain obvious effects. Under its influence the protoplasm is reduced to keratin and the skin becomes coarser and harder. This was studied by Unna.<sup>1</sup> Möller's experiments referred to in Chapter VI. proved that light sets up hyperplasia of the epidermis and an abnormal horning process.

A considerable histological experimentation has shown that there are produced local pathological changes in the body cells which are subjected to powerful light energy. Many of these experiments are quoted in these pages. By the same energy there is produced even upon normal skins, changes forming a recognized pathology. By the action of light there may be produced either the hyperæmia of the skin in its different phases or the action may be upon the conjunctiva, for example. As to whether this is due to an action upon the vascular nerves or to a primary injury of the tissue cells (degenerative) is not fully established.

Workmen in electric arc light plants suffer from this untoward action of light. The occurrence of intense erythema is not infrequent.

---

<sup>1</sup>Monatsh. f. Prakt. Dermatologie, 1885, IV., p. 284.

Pathological Effects of Light Energy Acting upon Abnormal or Supersensitive Skin.—In this connection it is purposed only to treat of the conditions arising from the action of solar energy, not that from an artificial source of light energy.

The skin of some people is much more susceptible to the influence of the sun's rays than others, as is commonly noted in the ease with which they suffer from sunburn, solar erythema, and both tan and freckle pigmentation. This is much more apt to be the case with the blonde type.

There exists then an extreme susceptibility of the integument which may be (1) congenital, or (2) acquired.

Under the first head may be instanced xeroderma pigmentosum and in certain cases hydroa vernale. Under the second condition may be mentioned eczema solare. These nutritive troubles of the skin are due to a special sensibility to the chemically effective energy of light. Such skins should on physical grounds always be thin as to epidermis and smooth in texture, that is easily penetrable, in order to be so afflicted. The lesion may be either determined in this way or a pre-existing lesion may be exaggerated. This will always be much less marked on the covered part of the body as in variola.

M. Möller has studied and written of this subject of the skin lesions produced by light. Their consideration while properly belonging to dermatology, are of equal importance in considering the effect of light.

Eczema Solare.—This is a condition due to the action of chemical light energy. There may be produced in this way a typical acute eczema, with swelling, itching, œdema, or some efflorescence analogous to that of urticaria, miliary vesicles, then a diffuse oozing, or a second or subacute form which is identical with a simple subacute lichen planus. There are isolated papules, sometimes confluent at certain points. In both forms the pruritus is a constant symptom.

---

<sup>1</sup>Der Einfluss des Lichtes auf die Haut in Gesundem und Krankhaftem Zustande, Bibliotheca Medica, Stuttgart, 1900.



If not re-exposed to the action of sunlight, pigmentation does not follow the eczematous lesions.

It will be recalled that Brocq (see chapter on Concentrated Arc Light Energy) mentions a case in which an exposure of light produced so violent an eczema with œdema as to prevent the therapeutic use of light energy. The eruption is strictly limited to the unprotected parts of the body. It is very precisely limited, for example, by the hat, the collar and the waistband. It appears in the spring. It may subside under rest in the house to return upon exposure to sunlight. It may appear even in winter and summer, and even from sojourning in the house. In this event it is produced by the visible chemical frequencies which filter through the window glass.

Treatment in this condition consists of rest in the house, and protecting the parts from the action of the chemical energy of light. This may be done by the wearing of either yellow or red veils, or by protecting the face with colored paste or ointments.

The first experiment in this direction on a scientific basis was made by Th. Veiel,<sup>1</sup> who cured violently persistently recurring eczema solare in the case of a lady by ordering the wearing of red veils.

Summer Prurigo or Prurigo Estivale of Hutchinson.—Under this name Hutchinson described an affection of the skin affecting the uncovered parts. It was accompanied by acneiform eruptions or papules of prurigo and associated with intense pruritus. Dermatologists no longer recognize this type, and it is believed that in his description Hutchinson confounded different affections. Hutchinson did not regard it as a condition exclusively estivale. Berliner, on the other hand, attributed it to the action of the chemical solar energy.

It is not regarded by Möller, however, as a direct effect of the solar rays. He believes that it should be considered

<sup>1</sup>Vierteljahrshchr. f. Derm. und Syph., 1897, p. 1113. Quoted by Freund.

under simple relapsing chronic prurigo of Brocq. It presents the symptomatology of this condition. In the cases published the manifestations of the disease were not limited to the uncovered part of the body. The attacks are the most intense during hot weather, but they are not absent in winter. There is no question but that the condition is aggravated by heat, but the name summer prurigo seems a misnomer.

Hydroa Vernale.—In 1860 Bazin described this rare condition, hydroa vernale or estivale. It was then forgotten until Handford described a new case of it in 1889.

The disease always begins to manifest itself in the spring time, which renders the qualifying name vernale preferable to that of estivale. Bazin described a vesiculo-bullous type, therefore the exclusive term of "vacciniform" is not only too exclusive but not good.

Since the first description quite a number of these cases have been observed, and Möller has collected 36 cases susceptible of the following grouping: (1) Vesiculo-bullous, and (2) a vacciniform variety. In common with many skin conditions, these types are not always distinctive, that is, clearly marked. They may run into one another. Again there may be an atypical variety.

The eruption appears upon the uncovered parts of the body, face and hands, and occurs in very young infants, rarely appearing after the age of 10.

In from 12 to 24 hours after exposure to vivid solar light, the first symptoms show themselves in the form of a chemical light erythema. The skin becomes red, tender, tumefied and hot. Subsequently isolated erythematous spots appear which increase in thickness and become infiltrated. Or these spots may appear without diffuse erythema. Gradually the spots become elevated, presenting a semi-transparent appearance on the top, of a clear color, forming a vesicle or bulla. Upon pricking the skin to draw out a little liquid, the cavity is not depressed, indicating that the bullae are multilocular. As the condition progresses they extend

upon the surface at the expense of the erythematous spots, which soon appears only as a fine, red areola. The contents of the bullæ sometimes become hemorrhagic. The lesions are generally isolated, more rarely grouped and are surrounded by a common erythematous zone.

When the eruption ends as the hydroa, vesiculo-bullous variety, the contents of the bullæ become dried, a crust forms which is gradually thrown off, leaving no cicatrix. Unless there has been secondary infection of the contents of the bullæ this type of the disease leaves no trace whatever. However the disease rarely assumes this benign type.

In the vacciniiform variety described by Bazin the bullæ sink slightly in the centre which assumes a deeper color becoming almost black. A clear ring around the spot indicates the remains of the bulla, this in turn is bounded by the red areola, which was present from the beginning. This is a transient appearance only, and there is subsequently observed nothing but a dry crust hard and closely attached to the skin. When this falls off it leaves a deep depressed cicatrix of a vacciniiform or varioliform nature.

This form of the disease is essentially relapsing. Successive lesions appear rapidly followed by extensive and grave alterations of the skin of the uncovered parts of the body, especially of the face. The latter becomes pitted with multiple cicatrices, which are white, flat or depressed and between which there can be found telangiectases and a diffused pigmentation.

In rare instances the eruption has been observed upon covered parts of the body and the ocular mucous membranes are sometimes affected.

So profound a nutritive disturbance of the skin, of an acute type, cannot take place without systematic symptoms and there have been observed gastric phenomena, malaise and cephalalgia. These are but transient symptoms, however. McCall Anderson observed in the cases of two brothers affected with hydroa vernale a red coloration of the urine due to the presence of hæmato-porphyrine. The

same symptoms have been observed by Möller. There is no definite cure and the condition may continue until puberty.

It is concluded that the vesicles and bullæ are due to the penetration of liquid between the cells of the epidermis, thereby forming cavities isolated one from the other by the flattened cells.

There exist in the derma signs of intense inflammation with vascular lesions. The superficial lesions are infiltrated by numerous cells, the vessels dilate, the walls become necrotic, the cavities are obliterated by thrombi and hemorrhages are found at some points. The entire corresponding region of the epidermis is necrosed. This results in the formation of an eschar which becomes deeper and deeper, not ending until the whole thickness of the derma is included.

By his experiments Möller established definitely the rôle of light in the production of accidents to the skin, exclusive of any other cause. In the case of a patient affected with hydroa vernale he succeeded in producing the cutaneous condition by exposing the part to the chemically effective energy of a fifteen-ampère arc alone. The exposure of a part of the body habitually covered to this energy produced an erythema with desquamation. Repeated exposures, however, were followed by the characteristic lesions of hydroa vernale.

Under normal conditions the normal skin acquires an immunity under the influence of chemical light energy. In hydroa vernale, however, no such immunity is acquired. On the contrary the skin becomes more and more acutely sensitive. It is not noted by those who have studied this disease, whether after the erythemata is produced, the skin of these patients become pigmented as in the physiological state.

The author hazards the opinion (without observed fact) that it does not, for if it did it would shield from subsequent attacks.

As it is possible for the chemically active energy to traverse clothing to a certain extent, the presence of the

lesions on uncovered parts of the body is to be accounted for. The ability of this energy to affect superficial layers of bedclothing as demonstrated by von Esmarch (see chapter on Bacteria) is also evidence of the transparency to a certain extent of the clothing.

To produce such extensive lesions of the skin and blood vessels even, there must be very great penetration of the chemically effective energy in these cases.

Ephelides.—The pigmented spots of which this lesion consists also appear upon the uncovered regions, especially upon the face. The dorsal aspect of the hands and arms when uncovered are affected next in order, while among the laboring classes where it is the custom to leave the chest exposed upon that region also. The covered parts of the body are but little affected.

The spots are round or oval and vary in size from that of a pin head to a ten-cent piece. Sometimes they become confluent and form irregular patches. They are flat, smooth and their color varies from a clear yellow to a yellow brown. As a rule their coloring is not deep. Histologically these lesions pertain to the epidermis especially. There may be observed at the level of the mucous body numerous pigmentary granules, and there are also some pigmentary cells. The etiological relation between ephelides and the action of light is very apparent.

Zeroderma Pigmentosum.<sup>1</sup>—This is a very rare disease which generally runs in families and shows itself in early childhood. A congenital nutritive error in the external integument plays the most important rôle in the pathogeny of this affection. Several children in a family may be affected. The disease usually comes on in spring after exposure to sunlight of the uncovered parts.

Under the influence of sunlight as an exciting cause there appears an erythematous or eczematous dermatitis upon the face, arms and legs. Unlike sunburn, the redness goes on

---

<sup>1</sup>Dermochromes, Jacobi-Pringle, Vol. II., p. 119.

increasing. After a time it gradually diminishes. These lesions serve as a basis for the development of numerous pigment spots of widely varying size and along with them telangiectases and warty growths which finally leave white atrophic pitted spots.

This atrophy may obtain considerable dimensions and the pigmentary spots become very numerous and extensive. The eczematous or pustular eruption tends to ulcerate and these ulcerations terminate in depressed cicatrices or keloids.

The especial feature of importance in this disease is the fact that even in early youth or even later malignant growths, carcinoma and sarcoma develop from the pigment spots and lead to secondary growths in other organs.

Diagnosis is apt to be difficult at first. Prognosis is absolutely unfavorable, and the malady may last for many years, 10 to 30.

Treatment.—This in the first place depends upon the exclusion of the frequencies of light energy active chemically. To this end yellow veils are to be worn or colored pastes used. In this way the blue frequencies are cut off. The tumors are to be removed by (1) surgical, (2) electrolytic measures. Relapses and metastases seldom fail however to recur.

Delayed Zeroderma Pigmentosum.—Unna has described the late development of cutaneous alterations identical with the preceding under the name of Carcinoma of the Skin of Sailors. At first there is observed a bluish-black condition of the skin of the uncovered regions. This is followed by isolated or confluent pigmentary or colorless spots. The skin becomes roughened and is covered in places with keratose projections. Multiple epitheliomata finally supervene, some of which have the character of cutaneous horn, while others are of a warty character. Both are destined to ulcerate and take the character of adult cutaneous epithelioma, if they have not disappeared under treatment.

Pellagra.—In this condition it is not a sensitive skin

abnormally influenced by light but a diseased skin upon which the light acts to complicate the pathological condition. It is first an erythematous cutaneous alteration then desquamating and is associated with a marked cachexia. There is great emaciation, digestive disorders or psychic manifestations. The erythema of pellagic patients is considered the most characteristic and most constant symptom. It follows the uncovered portions of the body and only comes on when the subject is cachectic, never as an initial phenomenon. In the beginning it seems like a solar erythema, coming on in spring and disappearing in the autumn. During this time it is accompanied by an erythema more or less abundant, which upon disappearance leaves the skin more shining and dry than normally.<sup>1</sup> It recurs in the following spring. Gradually the skin loses its elasticity and it thickens and fissures. The last stage of the disease is characterized by atrophy of the skin.<sup>2</sup>

According to Bouchard<sup>3</sup> pellagra is only a solar erythema developed in a pellagrous subject. In his experiments he showed that it was due to the chemical energy of solar light. It does not form an integral part of the syndrome pellagra, but is produced by virtue of the general state, involving as it must a malnutrition of the skin as well, rendering it susceptible to the untoward influence of light.

Variola.—Finsen's experimental work has established the action of light in the eruption of smallpox. The effect is again due to the chemical energy of light. Finsen regards the contents of the pustule of variola as very susceptible to the action of this chemical energy and that the suppurative progress is thus provoked. This is considered more at length in the chapter devoted to the exclusion of all the frequencies above the red in the treatment of smallpox and the exanthemata.

<sup>1</sup>Leloir and Vidal. *Traite des Malades de la Peau*, Paris, Mason, 1894.

<sup>2</sup>Raymond: *Les Altérations Cutanées de la pellagra*. *Ann. de dermatologie*, 1889, p. 267.

<sup>3</sup>*Recherches Nouvelles sur la pellagra*, Paris, 1862.

### Insolation.

Insolation.—By insolation in this connection is to be understood the condition known as sunstroke, when the effect is upon the nervous system, especially upon the supreme centres.

There may be distinguished an effect from (1) the more intense thermally active energy, and (2) the more intense chemically active energy. There is a difference of opinion as to the relation between the first and the second, and the condition recognized as sunstroke.

Statistics in this latitude would seem to show a much greater preponderance of accidents of this nature in atmospheric conditions of great humidity.

The infra-red frequencies exist in greatest numbers when there is great humidity, as their amount in sunlight depends upon the amount of vapor and carbonic acid in the atmosphere. This is an atmospheric condition which is badly borne by invalids and by those in health even. It is usually remarked that the heat would be readily borne were it not for the moisture, but from the physical fact of a great quantity of heat, i.e., infra-red frequencies in connection with excess of vapor and carbonic acid, the excesses of the infra-red frequencies must be a potent factor in the depressing influence of such an atmospheric condition.

There is also a very marked lessening of the frequencies, chemically active, of the blue violet region. Such ultra-violet as are usually present in the atmosphere at the earth's surface are largely absorbed by reason of the intense humidity. Moreover, the humidity of the atmosphere by the restriction of radiation contributes to the untoward effects of the intense heat.

Möller's experiments point to an injurious effect of the thermal energy. He found that heat radiation associated with ultra-violet radiation acted as did heat radiation alone when directed on the skin of the skull of rabbits. In this way there was produced more or less intense cerebral dis-



turbances, sometimes even sudden death. The autopsy showed, after intense irradiation, the skin of the head much swollen and a bloody, gelatinous exudation present in the subcutaneous tissue. The periosteum, the cranial bones, and the dura were discolored and covered with ecchymoses. The vessels of the brain surface were much dilated and showed numerous and in part confluent ecchymoses. When, however, the heat rays were filtered off and the ultra-violet rays alone applied no central disturbance was observable.

On the other hand, there is a good deal to say in favor of the relation between intense chemical light energy and the condition of insolation. There is also a certain clinical evidence to support this hypothesis.

In view of the well-known action of too intense chemical light energy upon plants and upon the skin and conjunctiva of man, for example, it seems rational from the physical side to believe that it must be equally effective in producing the condition of insolation which manifests itself by profound and long standing disturbances of the supreme nerve centres.

In the comparative calmness of the atmosphere, the clearness of the sky and the dryness of the air, the strongest insolation takes place. It is noted that persons become disabled in the deserts by insolation produced by excessive heat. The condition of humidity is practically unknown in arid desert regions. This would point to an action of the chemical energy of light.

In the ability of the chemical frequencies to dilate blood vessels can be found an explanation of the action of prolonged exposures to intense chemically active light energy.

If such a dilation be established superficially, it is not difficult to see how the deeper vessels of the meninges, for example, may become affected.

Insolation is an occasional cause of cerebral meningitis, influencing chiefly the convexity. The resulting meningitis is usually simple, not purulent. In cases of rapid death only indications of congestion are to be discovered.<sup>1</sup> Those who

<sup>1</sup>Gowers: Diseases of the Nervous System.

have suffered insolation rarely recover entirely from its effects. They remain very susceptible to the influence of light energy, and, in the author's experience, bright intense sunlight and the electric arc light are badly borne.

Cerebral irritability is increased under these conditions to an extreme degree. This is the more true of those whose lives are devoted to mental work. Insolation seems to be a factor in producing the neurasthenic state, and is not infrequently given as the exciting cause of insanity. Neurotics and alcoholics are much more apt to be the subjects of insolation than others, and recover from the untoward light action with difficulty.

It may be, and probably is, that there is a twofold etiological relation and, under certain conditions, both may be operative while again, as in humid atmospheric states, but the one, i.e., the thermal energy is active, while in clear dry atmospheric states with intense sunshine, the chemically active energy may be operative as an etiological factor. It is argued in behalf of the latter hypothesis that no one ever gets sunstroke from exposure to dark sources of heat, or where the luminous rays possess no degree of chemical energy, as, for example, the furnace in an arsenal. The argument is not flawless as dark heat has not the penetrating power of radiant heat, and workmen exposed to sources of intense dark heat are not infrequently overcome. Again, radiant thermal energy is not penetrative to the same degree as chemical light energy. The latter will pierce the clothing unless the color is such as to act as a filter.

In this connection the following prophylaxis of sunstroke is given. The experience of Duncan has been substantiated by that of others.

Prophylaxis of Sunstroke.—From his personal experience of sunstroke in India, Dr. Andrew Duncan<sup>1</sup> gives details of a method of prophylaxis which has served him well. During several successive years he suffered from severe

---

<sup>1</sup>Journal of Tropical Medicine, Aug. 15, 1902.

headaches, and during four hot seasons he had in addition intolerance of light and a tendency to unconsciousness.

Acting upon a suggestion made to him that the actinic rays, and not the heat rays of the sun, were the active agents in producing sunstroke, and that the effect would be counteracted if the body were enveloped as a photographer treats his plates in an orange-yellow wrapper, he wore an orange yellow shirt, placed a similar colored lining inside his service helmet and inside the coat over the spine. The influence of the sun was never felt to be overpowering after the use of this colored material.

The author is informed that in tropical countries yellow and red underclothing is often worn, the external dress being white. The former is used to filter out the chemical light energy, and the latter to serve as a reflecting surface.

As tissues can be made sensitive to the action of light energy by the use of suitable media, so also can they be protected from it by the use of agents which serve as filters.

### **The Pathological Effects of Electric Lighting.**

The action of electric light must not only be considered from the physiological point of view but the pathological as well. There seems to be some difference of opinion as to the effect of electric light upon the eye and its function. However, the consensus of opinion would indicate that in electric light we have an illumination that is capable of much greater injury to the eye than gas even, and very much greater than that of an oil lamp. In the incandescent light, the mercury vapor lamp and the electric arc the chemical intensity as well as the optical intensity is considerable in amount. In the first two instances the visible chemical frequencies, and in the last both the visible and invisible chemical frequencies or ultra-violet rays are active. In the use of incandescent lamps for the purpose of house illumination, there is an irritating effect from the long continued exposure to the visible chemical frequencies, by no means a small mat-

ter when the number of lamps in use is considered and the hours during which they are used. An oil lamp on the other hand is much less rich in actinic frequencies, and gives a light richer in the yellow frequencies, which is much softer and of which the eye is much more tolerant. It is stated that a Russian medical man,<sup>1</sup> whose name is not given in the reference, decided that electric light was the least injurious to the eyes, basing his conclusions upon the evidence of fatigue as indicated by the closure of the lids; that is, the more frequently the lids were closed, the greater the fatigue and consequent injury. From the experiments he made he found that the lids would close with different illuminations per minute, as follows:

Candle light .....	6.3
Gaslight .....	2.8
Sunlight .....	2.2
Electric light .....	1.8

On the other hand, a number of eminent oculists in London<sup>2</sup> agreed that the exposure of uncovered electric light in the streets and in shops and offices, was a means of very great danger to the eyesight of the populace. Experts were so greatly exercised in this matter that they even suggested that Parliament should take it up and prohibit the use of plain glass globes for electric light, unless they were properly shaded. There is no question but that the glare of such unshaded electric lights is extremely bad for the eye in house illumination, and not only discomfort but impaired vision results from their use. The author does not think that any very great harm can be done when they are used thus unprotected in the street. The ground glass globes commonly used are made for protection in the street. Dr. Gebhardt, of Budapest, raised an emphatic protest against the practice of putting electric incandescent lamps at a low level among the wares in shop windows. He regarded this as exceed-

<sup>1</sup>Phil. Med. Journal.

<sup>2</sup>Electrical Eng., London.

ingly destructive to the eyes, and in his opinion these lamps should always be put out of the direct range of vision. Not only is the eye unfavorably affected by the action of the intensely chemical activities of light upon the nerve itself, but severe conjunctivitis, and even retinitis may occur as the result of an exposure to ultra-violet rays. The following instances illustrate this fact very clearly.

Electric Light Conjunctivitis.—According to Grimsdale,<sup>1</sup> this disease has received scant acknowledgment in our literature. Several cases are reported, with varying symptoms. The disease is not serious, lasting usually but a few days, and is greatly relieved by the use of compresses. It is the ultra-violet rays, and not the general illumination, which produce the effect, as is evidenced by one of the cases reported. It is thought that dark yellow glasses would be better than the ordinary smoked tint in preventing both this and snow blindness. The conjunctivitis can hardly be due to direct injury, as there is an interval of quiescence after the immediate results have passed before the acute symptoms come on. It must be due to the disturbance of the nervous system, especially the vascular centres, by direct stimulation of the afferent nerves, or the rays cause some chemic change in the conjunctiva whose products act as strong irritants, producing local inflammation.

The effect upon the conjunctiva pointed out by Grimsdale, is, the author believes, without doubt, due to the influence upon the vascular centres. The influence of the short high frequencies or intense chemically active light energy upon the capillaries, as demonstrated by the experiments of Finsen, need only to be kept in mind to prove this assertion.

The electric light conjunctivitis is of not infrequent occurrence, even from sources of intense violet as well as ultra-violet energy used therapeutically. It is the operator in this instance who is apt to suffer. This was noted by Finsen and his assistants in their earlier experiments, before experi-

---

<sup>1</sup>Medical Press and Circular, April 23, 1902.

ence had taught them to take precautions, when especially on the day following their experiments, they would suffer from red, tender and swollen skins, and the eyes felt as if full of sand, were extremely sensitive to light and the conjunctivæ injected. The author has experienced these ill effects upon the eyes in handling powerful electric arcs, and has moreover noted an intense cerebral irritability from very frequent and prolonged use of the electric arc, in her practice. These ill effects upon the eye and central nerve system are obviated by the use of colored glasses.

Ultra-Violet Ray Burns of the Eye.—Of interest in this connection, Dr. A. W. Colcord,<sup>1</sup> of Clariton, Penn., reports the following occurrence:

An arc, 250 volts pressure, which was used to melt a hole through a pig iron plate, gave a current of 1500 ampères. The positive pole was grounded on the iron plate and the negative was connected to a carbon 2 inches in diameter and 2 feet long, attached to a 16 foot wooden handle.

With this a 6 inch hole was melted through a 3 foot iron plate in 8 hours. During this time three of the operators received severe burns of the eyes. As they stood from 10 to 15 feet away from the arc, where the heat was not so great, it is believed that the burns were produced by the ultra-violet rays of the arc light.

Case I.—Six hours after exposure had dimness of vision. In another hour there was swelling of the eyelids, puffing and congestion of conjunctiva, marked photophobia and lachrymation, with great pain in eyeballs and burning of conjunctiva. The symptoms, increased in severity for 2 or 3 hours, gradually subsiding in 24 hours; all save the dimness of vision, which persisted for 2 weeks. During that time the patient was unable to read ordinary print or to recognize a friend across the street. As he did not return for treatment during that time, Colcord was unable to make an examination of the retina, but believed that the dimness

---

<sup>1</sup>American Electro-Therapeutic and X Ray Era, Nov., 1903.

of vision was due to retinitis. There was also in this case a burn of the first degree of the entire face, with peeling of epidermis on the day after as in sunburn.

Case II.—Same general symptoms as in No. 1, but more pain, requiring three-quarter grain morphine hypodermically. There was some dimness of vision in this case, subsiding in a day or two.

Case III.—This case was similar to others, though recovering completely in two days.

The treatment adopted in all cases was rest in bed in a darkened room. A two per cent. solution of cocaine was used, but failed to afford much relief from the pain and burning. In all of the cases an ointment of bichlorid of mercury (one grain to five ounces of sterilized vaseline) was put into the eye, but proved very irritating and was discarded. This ointment had been successfully used for some time in all ordinary burns of the conjunctiva or cornea. The greatest relief in the cases reported was obtained from application of cold sweet cream from cow's milk and from cold compresses of boric acid solution. Colcord in his summary calls attention to the following peculiar features of these cases:

(1) The extremely high candle-power of this arc light, estimated by their electrician at 480,000 or 300 times as strong as an ordinary street lamp.

(2) Length of time elapsing from exposure till effects of burn are felt, longer than an ordinary burn, shorter than an X ray burn.

(3) Pain and burning out of all proportion to visible signs of inflammation.

(4) Failure of the remedies used in an ordinary burn of the eye.

(5) Tendency to rapid and complete recovery without scarring or other permanent effects.

From the fact that glass is not transparent to ultra-violet rays, Colcord recommends that those working with similar apparatus should wear large thick spectacles of red

glass. In this way not only the ultra-violet but the blue-violet frequencies also are cut off.

In view of the therapeutic uses of powerful electric arcs and of the chemical activity of the ultra-violet rays, the cases of Colcord are of the greatest interest. Lavrand<sup>1</sup> reported the case of an engineer who remained exposed for about an hour at a distance of about 3 feet to the rays given out by two 15 ampère connected arcs. He stood in the cone of the rays where the light was weak but the chemical activity was greatest. Three hours afterward he felt a tingling in his eyes and soon presented all the symptoms of sunstroke, lachrymation, redness of the skin of the face and tingling, and then very severe supra-orbital neuralgia. The distance from the source of light in this case was from one-third to one-fifth of that of Colcord's cases, the current 1/500 as much: the time of exposure but one-sixth as much, and the time of development of symptoms one-half of that of Colcord's cases. There was only slight action in the eye as compared with the cases reported and the symptoms were more those of an electric sunstroke.

The same cause operated in both instances, and care should be taken in prolonged using of the electric arc not to subject the eyes and head to its intense chemical activity without suitable protection.

Electric Amblyopia.—In discussing the effect of electricity on the eyes, Galezawski<sup>2</sup> states that this is a lasting visual disturbance provoked by habitual exposure of the eyes to electric light indoors. He finds that the electric light can produce (1) amblyopia without any material lesion of the ocular fundus; (2) photophobia following on lachrymation due to intense retinal excitation; (3) central scotoma, simulated amblyopia, which must be recognized to avoid falling into error. These latter cases are usually in operatives who seek to obtain an increased premium. Among the

---

<sup>1</sup>Journal de Sciences Médicales de Lille, May 21, 1898.

<sup>2</sup>Rec. d'ophth., September; Giornale internazionale delle scienze mediche, September 30.



therapeutic measures recommended are the use of uranium spectacles and the application of cold compresses or ice bags to the eyes two or three times a day.

Color Blindness from Exposure to the Light of the Arc.—An electrical engineer,<sup>1</sup> after experimenting with a 45-ampère arc for about three hours, during which time no ill effects upon the eyesight were observed, left the laboratory and, on his way home, noticed that all gas and electric lights appeared to be of a deep red color. Red spots also appeared when looking in a mirror or at any polished surface.

After a day or two the red seemed to disappear and the lights appeared of a purple color for about a week, when he was again able to distinguish colors in gas and electric lights. There was no ill effect or pain accompanying this temporary color blindness, so to speak.

Another effect of the arc was to cause a severe sunburn, the skin, however, peeling worse than from a severe sunburn.

Here the exposure was to the direct energy of the arc itself as the experimental work being done required that the operator should be placed with his eyes but a few inches from the arc. The nature of the work was such that the colored glasses usually worn hampered observations, and were therefore discarded.

Concerning the ampèrage of the arc, his nearness to it and the length of the exposure, it is strange that electric light conjunctivitis was not suffered as well.

The Ignition of Ether Vapor in Presence of a Closed Electric Light.—Dwight H. Murray<sup>2</sup> reports that on the 19th of January, while engaged in a difficult and tedious operation his attention was taken from his work by a sudden flash of light and quick movements on the part of the anæsthetist. He found that the ether vapor had ignited, scorching the hair and eyebrow of the patient and had burned the skin on the forehead sufficiently to cause a marked red-

---

<sup>1</sup>Personal communication.

<sup>2</sup>New York Medical Journal and Philadelphia Medical Journal, June 27, 1903.

ness. The anæsthetist reported that, being unable to see the pupil distinctly the patient lying face downward, he turned on the electric light in order to more readily note the reaction of the pupil. The blaze was coincident with the turning on of the light. Murray states that he has never seen any such accident reported, and cautions operators not to turn electric lights on or off near the vapor of ether, particularly in a small room. In the above instance there was no exposed fire or blaze in the operating room. Upon attempting to repeat the condition experimentally he found it impossible. While his experience may not be unique it is certainly rare and the surgeon should bear in mind that it is a possibility. He concluded that ignition took place from the spark of the electric light burner made when contact took place from the turning on of the light.

The Element of Danger in the Preparation of Electric Arc Carbons.—In the preparation of carbons for the electric arc the operator is exposed to the action of the powdered carbon for many hours a day through long periods of time and the results are sometimes disastrous. While this is not a direct effect of light, it is a pathological aspect of electric lighting.

At a meeting of the Academy of Medicine, Paris, Monsieur Lancereaux<sup>1</sup> exhibited the lungs of a polisher of carbon terminals for the electric arc light, the said organ being transformed into veritable blocks of carbon and large vomiceæ being also discovered. Up to the age of 36 years, the deceased was a vigorous stone mason. At that time he was transferred to a workshop 8 metres long by 7 broad, where with eight other men he was engaged as a polisher on stone mills, of charcoal for electric lighting purposes. The shop was so badly ventilated that sometimes the men could not distinguish each other through the charcoal and stone dust filling the atmosphere. For six years the man was employed in this way, each day's work extending to 10 or 12

---

<sup>1</sup>The Lancet, London, December 2, 1893, p. 1418.

hours. For a year before he ceased to work all together, he had coughed and expectorated black sputa. In the winter of 1890-91, he was admitted into the hospital for bronchitis after influenza, and he was then expectorating black sputa in large quantities, in which particles of carbon could easily be distinguished under the microscope and by chemical tests, i.e., resistance to strong acid. He was admitted in 1892 in an emaciated condition, and bacilli could be detected in the black sputa secreted by the numerous cavities. In reporting this case, Monsieur Lancereaux stated that every new industry that springs up is worthy of the physician's notice in the new dangers to health that may thus be created.

**Illumination of Rooms in Relation to Mental Work.**—The question as to whether mental work can be accomplished under the best possible conditions in a room in which only the centre of work, the writing table, etc., is brilliantly illuminated and the walls comparatively dark, is variously answered by different observers. Katz finds in discussing the subject that some assert that it is better to have dark walls upon which the eye may rest in the intervals of work, when it is fixed upon a brightly lit surface, as in reading or writing; while others say that the transition from light to darkness is not a rest to the eye, but a positive strain upon it, and hold that the walls of a study should be well illuminated as well as the table. He holds to the latter view. He finds that working in a room illuminated by a lamp that is shaded so as to exclude light from the walls produces a depressing sensation in most individuals, and gives rise in many upon whom he has experimented to a feeling of lassitude and an irresistible somnolence. On the other hand, when the walls were properly lit there was a greater capacity for work with freedom from somnolence. This increased energy and freedom from somnolence increased in proportion to the brightness of the room. His study of the subject shows that the somnolence was not due to lassitude from the day's work, but was produced merely by the abstraction of the necessary

light energy. The question is raised as to what it is in artificial light that is depressing to the nerves. Is it the incompleteness of its spectrum or the insufficiency of light as compared to darkness? Trivus, of Bechterew's<sup>1</sup> psychological laboratory, shows by experiments that various colored lights have depressing effects upon the rate and volume of the pulse wave. The nerves demand a certain amount of light for their activity, and as each color is but a part of the spectrum of the rays of the sun, it follows that colored light cannot give the same energy as white light. Hence, if a subject be placed in colored light he suffers from what might be called "light hunger." Thus, yellow light being in the brightest part of the spectrum does not affect the pulse rate as much as violet light, which is the darkest part of it. The writer believes, however, from his experiments on persons and their capacity for work in artificial light, that it is not the part of the spectrum that counts, but the insufficiency in the amount of light energy that acts to depress the brain and nervous system. The conclusion is reached, therefore, that the use of colored shades for softening the light in work rooms and its centralization in such a way as to leave the walls in semi-darkness, is wrong from the hygienic point of view.

On the other hand, in the author's experience, it has happened that too intense brightness of the walls of a study, has served to produce a condition of such intense cerebral irritability as to prevent the best mental effort. This may happen both in the city and the country in the summer season when the sunlight is at its brightest, but is especially apt to be the case at the seashore, where in addition to the bright light the sea serves as a mirror to reflect the light. It is also more acutely felt in those whose brains are irritable, by reason of overstrain, or where insolation has been suffered. In so far as the walls of a study illuminated by artificial light is concerned, a reasonable degree of illumination is necessary to the best mental activity. The transition from

---

<sup>1</sup>Quoted at length in Chapter VII.

light to darkness when the eye is raised momentarily, is, under these circumstances, not restful, but rather a further strain. This is especially felt when the object of the momentary change is due to the need of consulting a book of reference in the book-cases with which the study walls are usually lined. If instead of work involving mental effort, the object of the light is to enable the occupants of the room to read for diversion only, then the single unit of light, in the softly shaded light of the petroleum oil lamp, furnishes the best of illuminating devices for the eye. The same source of light is always the best for night work. The spectrum of this source of light does not act as an irritant to the eye itself as does electric light. The latter is too chemically active, even with the incandescent, for the maintenance of the best ocular and optical conditions.

Conclusion.—The entire subject of light energy in its physiologic and therapeutic relation still calls for scientific study and experiment as well as for carefully analyzed and recorded clinical observations.

That this volume may inspire and stimulate both is the author's hope.



## INDEX.

### A

- Aberration, spherical and chromatic, 37.  
Abnormal dispersion, 39.  
Absorbed light, action of, 76.  
Absorption, 9, 52, 73.  
Absorption of heat, 48.  
Absorption of luminous heat, 59.  
Absorption spectra, 73, 74.  
Absorption in ultra-violet region, 609.  
Accessory conditions in bacterial action of light, 166.  
Acne rosacea, concentrated electric arc energy in, 512.  
Acne rosacea, ultra-violet light in, 639.  
Acne vulgaris, concentrated electric arc energy in, 511.  
Acne vulgaris, ultra-violet light in, 639.  
Actinometer, 29.  
Actinolyte, 482.  
Actinauxism, 147.  
Adrenalin, 495-497.  
Aërobic life, influence of light upon, 136.  
Agitation, mechanical, of germs, 192-194.  
Alpha rays, 22, 706.  
Alternating-current arcs, 106.  
Alternating-current arc baths, 394, 395.  
Alternating-current arcs in relation to concentration and condensation, 468.  
Amblyopia, electric, 806.  
Ammonia-copper sulphate, opaque to ultra-violet energy, 440.  
Amœbæ, action of light upon, experiments of Dreyer, 780.  
Amœbæ, action of light upon, experiments of Harrington and Leaming, 779.  
Amœbæ, action of light upon, experiments of Verworn and Davenport, 780.  
Ampèreage, wiring in relation to, 468.  
Anæmia and chlorosis, arc light baths in 388, 389.  
Anæmia and chlorosis, incandescent light baths in, 425.  
Anæmia and chlorosis, sun baths in, 322.  
Analogy between light and sound, 23.  
Angstroms, 67.  
Animals, cutaneous sensibility to chemical rays, 208-210.  
Animals, heliotropism of, 210-212.  
Animals, influence of light upon development of, 204-207.  
Animals, influence of light upon movements of, 208.  
Animals, influence of light upon vital activity of, 217.  
Animals, variations in weight in light and darkness, 218.  
Apparatus, Bellini's, 476.  
Apparatus for blue light, 561, 562.  
Apparatus, care of, 491.  
Apparatus of Finsen and Lortet-Genoud (Victor), comparison of, 475.  
Apparatus, Finsen-Reyn, 475.  
Apparatus, Lortet-Genoud, 471-475.  
Apparatus for ultra-violet light, 623-629.  
Apparatus for vacuum tube discharges, 666, 667.  
Arc, electric, candle-power of, 93.  
Arc, electric, crater of, 87-90.  
Arc, electric, current of, 92.  
Arc, electric, disinfectant action of, 124.  
Arc, electric, electromotive force of, 92.

Arc, electric, hissing of, 105.  
 Arc, electric, history of, 82.  
 Arc, electric, length of, in relation to ultra-violet energy, 93.  
 Arc, electric, mist of, 98, 103.  
 Arc, electric, phenomena of, 85.  
 Arc, electric, potential difference in relation to negative electrons, 92.  
 Arc, electric, temperature of, 88.  
 Arc, electric, vapor light of, 90, 91.  
 Arc light baths in anæmia and chlorosis, 388, 389.  
 Arc light baths in bronchitis, 375.  
 Arc light baths, cabinet for, 334, 336.  
 Arc light baths, cabinet for, combined with incandescent cabinet, 337, 338, 406.  
 Arc light baths, in enuresis, 376, 377.  
 Arc light baths in eczema, 378.  
 Arc light baths, history of, 328, 333.  
 Arc light baths, Finsen's, 336.  
 Arc light baths in neurasthenia, 322.  
 Arc light baths in nervous diseases, 381-387.  
 Arc light baths in psoriasis, 379.  
 Arc light baths in tuberculosis, 341-373.  
 Assimilation and disassimilation, influence of light upon, 218.  
 Assimilation and disassimilation, influence of different frequencies upon, 283.  
 Arterio - sclerosis, incandescent baths in, 429.  
 Athermancy, 58.  
 Atmospheric absorption, 55.  
 Atmospheric conditions, influence of, 80.  
 Aurora, 10, 655, 656.

## B

Bacteria, action of isolated frequencies upon, 168.  
 Bacteria, action of radium upon, 726.  
 Bacteria, sensitization of, 189-192.  
 Bacterial lamps, 197.  
 Bacterial species, modifications of, by temperature and culture media, 164.

Bacterial species, transformation of, under influence of light energy, 163.  
 Bactericidal action of light, 175-189.  
 Bactericidal action of light affected by nature of arc electrodes, 184, 185.  
 Bactericidal action of light affected by passage through water, 186, 187.  
 Bactericidal action of light, bibliography of, 173.  
 Bactericidal action of light, experiments by Freund, Bie, Bang, Bernard and Morgan, 176-189.  
 Bactericidal action of light in relation to oxygen, 194.  
 Bactericidal action of light, rôle of accessory conditions in, 166.  
 Bands of solar spectrum, 41.  
 Baths, alternating electric arc, 394, 395.  
 Baths, arc light, 328-371.  
 Baths, incandescent light, 401-435.  
 Baths, light and air, 318.  
 Basedow's disease, treatment by condensed solar light, 456.  
 Becquerel rays, 8, 694.  
 Becquerel rays, properties of, 476.  
 Bellini, apparatus of, 476.  
 Beta rays, 22, 707-710.  
 Blossoming of plants, influence of light upon, 155.  
 Blue glass screens, 478.  
 Blue light energy, apparatus for, 561, 562.  
 Blue light energy in catarrhal inflammations of throat, 572, 573.  
 Blue light energy, experiments by Kaiser, 559, 560.  
 Blue light energy, influence of, upon excitability of cerebral cortex, 291-300.  
 Blue light energy in lupus vulgaris and erythematosus, 562.  
 Blue light energy in neuralgia, 572.  
 Blue light energy, Minim's use of, in wounds, 564-566.  
 Blue light energy in minor surgical conditions, 567, 572.  
 Blue light energy in pemphigus, chronic, 637, 638.



- Blue light energy with red light energy (Pancoast), 563, 564.  
 Blue light energy in tubercular ulcer, 563.  
 Blood, absorbing power of, 274-276.  
 Blood, action of light upon, 265-270.  
 Blood a fluorescent body, 276.  
 Bolometer, Langley's, 9, 54, 55.  
 Bromid of radium, 716.  
 Bronchitis, arc light baths in, 375.  
 Brush discharges, 9, 10.  
 Brush discharges in skin conditions, 632.  
 Buckwheat, fluorescent principle of, 776.  
 Buusen's photometer, 28.  
 Burning mirrors, 47, 437.
- C
- Cabinet, arc light, 334, 336.  
 Cabinet, arc light, combined with incandescent, 337, 338, 406.  
 Calorescence, 57, 77.  
 Canalstrahlen, 20.  
 Cancer, radium in, 738.  
 Cancer cells, effect of radium upon, 742.  
 Candle-power of lamps at Finsen's Institute, 94.  
 Candle-power of reflected light, 38.  
 Carbon, temperature of boiling, 96.  
 Carbon, spectrum of, 491.  
 Carbon, vapor of, 90.  
 Carbon, volatilization of, 87.  
 Carbons for electric arcs, 108-113, 808.  
 Carbons, purity of, in relation to crater, 89.  
 Carbons, relative consumption with continuous and alternating current, 93.  
 Carbons, resistance of, 480.  
 Cardiac hypertrophy and dropsy, incandescent bath for, 427.  
 Cathode rays, 16, 653, 665.  
 Chemical action of light, 4.  
 Chemical effects of light, 77.  
 Chemical efficiency of incandescent light, 399.  
 Chemical frequencies, their exclusion in the psychoses, 599-601.  
 Chemical frequencies, visible, 573-578.  
 Chemical light reaction not a destructive process, 532.  
 Chemical rays, promoters of energy, 213.  
 Chemical effects of radium, 713.  
 Chlorophyll, necessity of light for development of, 142.  
 Chlorophyll assimilation, effective frequencies for, 145.  
 Chlorophyll assimilation, nature of, 144.  
 Chlorophyll assimilation, light energy in relation to, 143.  
 Chorea minor, treatment by condensed solar light, 455.  
 Chromosphere, 42.  
 Ciliated corpuscle, action of light upon, 137.  
 Color blindness, electric, 807.  
 Color of bodies in relation to color of spectrum, 78.  
 Colored light, influence upon nervous system, 288.  
 Complementary colors, theory of, 146.  
 Complex of chemically active light energy, 440.  
 Compression of tissues, 492-496.  
 Concave mirrors, 32.  
 Concentrated electric arc energy in acne rosacea, 512.  
 Concentrated electric arc energy in acne vulgaris, 511.  
 Concentrated electric arc energy in alopecia areata, 513-515.  
 Concentrated electric arc energy in eczema, 511.  
 Concentrated electric arc energy in gynæcology, 528, 529.  
 Concentrated electric arc energy in leprosy, 517.  
 Concentrated electric arc energy in lupus erythematosus, 508-511.  
 Concentrated electric arc energy, macroscopic reactions from, 532.  
 Concentrated electric arc energy, methods of use, 492.  
 Concentrated electric arc energy, microscopic reactions from, 533.  
 Concentrated electric arc energy in nevus vasculosus, 516, 517.  
 Concentrated electric arc energy,

- nature of changes established by, 530.
- Concentrated electric arc energy in recent inflammations and injuries, 524.
- Concentrated electric arc energy in rodent ulcer, 516.
- Concentrated electric arc energy in septic processes, 518-520.
- Concentrated electric arc energy in synovitis, 523, 524.
- Concentrated electric arc energy, therapeutic indications in tuberculosis pulmonalis, 526.
- Concentrated electric arc energy, therapeutic indications in tubercular joints, 520-523.
- Concentrated electric arc energy in tubercular ulcer, 525.
- Concentrated electric arc energy, use of, in parasitic diseases, vegetable, ringworm, favus, pityriasis versicolor, sycosis, 507, 508.
- Concentrated incandescent light energy in gynaecology, 554-556.
- Concentrated incandescent light energy, mechanisms for, in the treatment of joints, 541, 544.
- Concentrated incandescent light energy in the treatment of mucous membranes, 548-550.
- Concentrated light energy in otitis media, 557.
- Concentrated light energy in ozæna, 557.
- Condensed solar light, 438.
- Condensed solar light in Basedow's disease, 456.
- Condensed solar light in chorea minor, 455.
- Condensed solar light in diphtheritic croup, 455.
- Condensed solar light in Keratitis, suppurative, 443.
- Condensed solar light in laryngitis, tubercular, 443, 646.
- Condensed solar light in laryngitis, syphilitic, 646.
- Condensed solar light in lobar pneumonia, 454.
- Condensed solar light in lupus, 444.
- Condensed solar light in lymphangitis tuberculo-gummatosa, 452.
- Condensed solar light in malignant pustule, 447-450.
- Condensed solar light in neuralgia, sciatic, 456.
- Condensed solar light in orrhythmia, 458.
- Condensed solar light in peritonitis, tubercular, 453.
- Condensed solar light in pertussis, 450.
- Concentrated solar light, photographic ray filter for concentrating, 439.
- Concentrated solar light in polidemia, tubercular, 453.
- Concentrated solar light in skin affections, chronic, 444.
- Concentrated solar light in tic douloureux, 457.
- Concentrated solar light in tuberculosis, pulmonary, 445.
- Concentrator, Finsen's, 466-468.
- Conduction, electrical, how affected by gases, 651.
- Conjunctivitis, electric light, 803.
- Contractile pigment cells, changes of, form under influence of light, 217.
- Cortex, cerebral, influence of red and blue light upon excitability of, 291-300.
- Contra-indications for incandescent light baths, 435.
- Convergent rays, 25.
- Convex lenses, 36, 37.
- Cornell Univ. experiments, 161, 162.
- Corona, 42.
- Corpuscular theory, 3-6.
- Cosmetic effect of light treatment, 504, 505.
- Crater of electric arc, 87.
- Crater of electric arc in relation to amount of light emitted, 91.
- Crater of electric arc, temperature of, 88.
- Crookes electrons, 7.
- Crookes radiometer, 62.
- Cuban firefly, luminous efficiency of, 98.
- Cutaneous investment of animals, sensibility of, to chemical rays, 208-210.

## D

- Darkness, life of plants in, 142.  
 Dehérain's experiments, 159-161.  
 Decomposing power of light, 235, 236.  
 Diabetes, incandescent light bath in, 424.  
 Diabetes, electric arc in, 387-389.  
 Diathermancy, 58.  
 Diffraction, 66.  
 Disactivation, 721.  
 Disinfectant action of light on rivers, 175.  
 Dispersion, 38.  
 Dispersion, Helmholtz' theory of, 14.  
 Divergent rays, 25.

## E

- Eczema, arc light baths in, 378.  
 Eczema, concentrated electric arc energy in, 511.  
 Eczema produced by light, 506.  
 Eczema solare, rôle of light in production of, 791.  
 Effects, physical, of light energy, 224-235.  
 Electric arc in anæmia and chlorosis, 388, 389.  
 Electric arc in diabetes, 387, 388.  
 Electric arc in hay fever, 374.  
 Electric arc in locomotor ataxia, 390-394.  
 Electric arc, mechanisms and methods of use, 330.  
 Electric arc in nervous diseases, 380-387.  
 Electric arc, regulators of, 113.  
 Electric color blindness, 807.  
 Electric light conjunctivitis, 803.  
 Electric light effects on plant life, Cornell Univ. experiments, 161, 162.  
 Electric light effects on, Dehérain's experiments, 159-161.  
 Electric light effects on, Siemens experiments, 155.  
 Electric light effects on the eye, 801-803.  
 Electrode contacts, nature of, 463, 464.  
 Elementary forms of life, action of different frequencies upon, 137.

- Energy, curves of different light sources, Langley, 128, 129.  
 Energy defined, 1.  
 Energy, ultra-violet, 603, 627, 628, 640-644.  
 Enuresis, arc light baths in, 376, 377.  
 Enzymes, action of light upon, 199-201.  
 Ephelides, rôle of light in production of, 795.  
 Epithelioma, concentrated electric arc energy in, 512, 513.  
 Epithelioma, radium in, 734-737.  
 Equilibrium, mobile, 46.  
 Erythema, electric arc, 240.  
 Erythema, solar, 239.  
 Ether, nature of, 1.  
 Ether vapor, ignition of, 807.  
 Exposures, frequency of, 498.  
 Exposures, length of, 497.  
 Exudates, influence of incandescent light baths upon absorption of, 424.  
 Eye, electric light effects upon, 801-803.  
 Eye, radium effects upon, 732.  
 Eye, ultra-violet rays upon, 804.

## F

- Faculæ, 40.  
 Finsen Light Institute, comparison of apparatus at, 475.  
 Finsen Light Institute, statistics for 1904, 460.  
 Finsen Light Institute, tests of apparatus at, 482, 483.  
 Finsen's arc light baths, 336.  
 Finsen's concentrator, 466-468.  
 Finsen's experiments on skin of forearm, 254, 255.  
 Finsen's technique, 502-504.  
 Finsen-Reyn apparatus, 475.  
 Fluorescence, 77.  
 Fluorescence and absorption, 74.  
 Fluorescence, ancient knowledge of, 751.  
 Fluorescence of blood and lymph-serum, 758.  
 Fluorescence of buckwheat, 776.  
 Fluorescence of quinin and other substances, 755-758.  
 Fluorescence of radium, 712-715.  
 Fluorescence in relation to absorption and emission, 753-755.

- Fluorescence, sensitization, in relation to, 774, 775.  
 Fluorescence of vacuum tubes, 651.  
 Fluorescent bodies, 276.  
 Fluorescent illumination, action of, upon infusoria, 759, 777.  
 Fluorescent stimulation, action upon ciliary epithelium, 763-770.  
 Fluorescent stimulation in relation to chlorophyll absorption, 761.  
 Fluorescent stimulation in cancer, Hodgkin's disease, lupus, and syphilis, 763-766.  
 Fluorescent substances, action of, upon infusoria, 768.  
 Fluorescent substances, action of, internally, upon skin surfaces and in mucous cavities, 762.  
 Fluorescent transillumination, 786, 787.  
 Focal length, 34.  
 Focal length of a lens, 37.  
 Fotocauterio of Sciascia, 446.  
 Fraunhofer's lines, 67, 68, 86.  
 Frequencies, synonymous with rays.  
 Frequencies, ultra-violet, 256, 258, 573, 617-620.
- G
- Gamma rays, 22, 707.  
 Gas, insulation of, in relation to pressure and temperature, 651.  
 Gases of the electric arc, 114.  
 Gases of the electric arc, conductivity of, 660.  
 Gases of the electric arc bath, 338, 339.  
 Geissler tubes, 655-657.  
 Germs, mechanical agitation of, 192-194.  
 Glacial sunburn, 239.  
 Glass, transparency of, in relation to wave length, 611.  
 Glebowsky, observations of, upon lupus, 535, 536.  
 Goitres, 56.  
 Görl spark lamp, 623.  
 Gout, incandescent light baths for, 422, 423.  
 Gratings, 55, 66.  
 Growth of plants, influence of light upon, 147, 239.
- Gynæcological work, water-cooled lamp for, 550-552.  
 Gynæcology, concentrated electric arc energy in, 528, 529.  
 Gynæcology, indications for use of concentrated incandescent light in, 554-556.  
 Gynæcology, photo-speculum for use of light in, 552-554.
- H
- Hay fever, electric arc in, 374.  
 Heat, sources of, 62.  
 Heliotropism, 149.  
 Heliotropism of animals, 210-212.  
 Helium, 716.  
 Helmholtz's theory of dispersion, 14.  
 Hemoglobin, spectrum of, 270.  
 Hydroa vernale, 792-795.  
 Hygiene and sanitation, action of light energy upon, 201-203.
- I
- Illumination of rooms in relation to mental work, 809-811.  
 Incandescent light, chemical efficiency of, 399.  
 Incandescent light lamps, life of, 398.  
 Incandescent light for therapeutic purposes, 397.  
 Incandescent light baths, advantages over hot air or vapor baths, 407.  
 Incandescent light baths, contra-indications, 435.  
 Incandescent light baths, first introduction of, 401.  
 Incandescent light baths, influence upon absorption of exudates, 434.  
 Incandescent light baths, influence of upon bacteria, 414.  
 Incandescent light baths, influence of upon body temperature, 413.  
 Incandescent light baths, influence of upon heart and respiration, 411, 412.  
 Incandescent light baths, influence of upon skin, 409.  
 Incandescent light baths, influence of upon sudation, 409.  
 Incandescent light baths, influence of upon urinary secretion, 413.

- Incandescent light baths, influence of upon weight, 413.
- Incandescent light baths, local baths, effect on skin temperature, 545.
- Incandescent light baths, local baths, technique of, 547.
- Incandescent light baths, local baths, temperature of, 544.
- Incandescent light baths, local baths, therapeutic indications for, 545, 547.
- Incandescent light baths, mechanisms, 402-406.
- Incandescent light baths, mode of action, 415.
- Incandescent light baths, technique of, 418, 419.
- Incandescent light baths, therapeutic effects, 417, 418.
- Incandescent light baths, therapeutic indications for, 417.
- Incandescent light baths, untoward effect upon the heart, 428.
- Incandescent light baths, use in anemia and chlorosis, 425.
- Incandescent light baths, use in arterio-sclerosis, 429.
- Incandescent light baths, use in cardiac dropsy, 427.
- Incandescent light baths, use in cardiac hypertrophy, 427.
- Incandescent light baths, use in diabetes, 424.
- Incandescent light baths, use in gout, 422, 423.
- Incandescent light baths, use in health, 416.
- Incandescent light baths, use in nephritis, 429.
- Incandescent light baths, use in nervous diseases, 426, 427.
- Incandescent light baths, use in obesity, 420-422.
- Incandescent light baths, use in respiratory diseases, 427.
- Incandescent light baths, use in rheumatism, 422, 423.
- Incandescent light baths, use in rheumatoid arthritis, 423, 424.
- Incandescent light baths, use in toxæmias, 430-434.
- Incandescent light energy, concentrated, 541-558.
- Index of refraction, 35, 37.
- Induced radio-activity, 720-723, 747.
- Induction coil lamps, 624, 625.
- Inflammations and injuries, recent, concentrated electric arc energy in, 524.
- Infra-red spectrum, how visible, 76.
- Insolation, see Sunstroke.
- Intensity of light and its laws, 26.
- Intensity of sunlight, 3.
- Internal organs, action of light energy upon their functions, 303, 304.
- Ionization of air by electric arc, 123.
- Ionization relative, of Roentgen rays, cathode rays, radium rays, polonium rays and uranium rays, Thomson's table of, 716.
- Iron-cored electrodes, 97.
- Iron electrode arcs, 483.
- Iron electrode lamp, functions of, 491.
- Iron electrode lamps, 484-489.
- J
- Joints, tubercular, concentrated electric arc energy in, 520, 523.
- Joints, tubercular, sun baths in, 315, 317.
- K
- Keratitis, suppurative, treatment by condensed solar light, 443.
- Kirchhoff's law of absorption, 73.
- L
- Lamp, bacterial, 197.
- Lamp, incandescent, life of, 398.
- Lamp, iron electrode (Bang), 484-489.
- Lamp, mercury vapor (Cooper-Hewitt), 125, 658, 659.
- Lamp, Minim, 578, 580.
- Lamp, Nernst, 400.
- Lamp, Piffard induction coil arc, 625.
- Lamp, St. Bartholemew's induction coil, 624.
- Lamp, spark, 623-629.

- Lamp, water-cooled, for gynæcological work, 550-552.  
 Lamp, ultra-violet, from alternating current arc, 629.  
 Laryngitis, tubercular, treatment by condensed solar light, 443, 646.  
 Laryngitis, syphilitic, 646.  
 Law, Kirchhoff's, 73.  
 Laws governing heat radiation, 44.  
 Laws governing light intensity, 26.  
 Laws of refraction, 34.  
 Lenard's rays, 18.  
 Lens, compressing, 497.  
 Lens, water-cooled compressing, 469, 470.  
 Lenses, 36.  
 Lenses, effects dependent upon, 37.  
 Lenses of quartz, 470, 471.  
 Leprosy, concentrated electric arc energy in, 517.  
 Leredde and Pautrier, reactions in lupus as observed by, 536, 539.  
 Light and air baths, 318.  
 Light, decomposing power of, 235-236.  
 Light, incandescent for therapeutic purposes, 397.  
 Light, influence of, upon pulse, respiration and temperature, 284.  
 Light, magnesium, 80.  
 Light, manifestations of, 7.  
 Light, measurement of, 29, 30.  
 Light, penetration of, 53.  
 Light, perception of, by retina, 24.  
 Light, production of, by micro-organisms, theories of, 199.  
 Light, propagation of, 25.  
 Light, quantity of, 469.  
 Light, red, 291-300, 581-598.  
 Light, standards of, 27.  
 Light, theory of, 10.  
 Light, ultra-violet, 607-639.  
 Light, velocity of, 26.  
 Living tissues, penetration, absorption and transmission of light by, 408.  
 Local incandescent light baths, 545-547.  
 Localization, marine searchlight adjustments for, 478-480.  
 Locomotor ataxia, electric arc in, 390, 394.  
 Lortet-Genoud apparatus, 471-475.  
 Luminescence, 18.  
 Luminescence of vacuum tube, 657.  
 Luminous bodies, 39.  
 Luminous efficiency of the Cuban firefly, 98.  
 Luminous efficiency of the electric arc, 98.  
 Lupus, condensed solar light for, 438.  
 Lupus erythematosus, concentrated electric arc energy in, 508-511.  
 Lupus, Finsen's treatment of, 502-504.  
 Lupus, fluorescent stimulation in, 763-766.  
 Lupus, Glebowsky's observations upon, 535, 536.  
 Lupus, radium in, 734-737.  
 Lymphangitis, tuberculo-gummatosa, 452.  
 Lymph-serum as a fluorescent body, 276.
- M
- Magnesium light, 80.  
 Magnetic field, influence of, upon alternating-current arcs, 107.  
 Malaria, Busck's conclusions in regard to King's hypothesis, 780-783.  
 Malaria, King's hypothesis as to action of light upon, 778.  
 Malaria, quinin in, Busck's conclusions upon, 784.  
 Malignant diseases, inoperable, radium in, 744.  
 Malignant pustule, treatment by condensed solar light, 447-450.  
 Mangin mirror, 33, 481, 482.  
 Manifestations of light, 7.  
 Marine searchlight, adjustment for localization, 478-480.  
 Marine searchlight, mechanisms for, 477.  
 Marine searchlight, use of, in tuberculosis, 350.  
 Mass of negative corpuscle, 3.  
 Measurement of light, 29, 30.  
 Measurement of radiant heat, 44.  
 Mechanical agitation of germs, 192-194.  
 Mechanical effects of light, 78.

Mechanisms for electric arc baths, 330.  
 Mechanisms, marine searchlight, 447.  
 Mechanisms, incandescent light, 402-406.  
 Mechanisms for ultra-violet light, 623-629.  
 Mechanisms for use of vacuum tube, 666, 667.  
 Mental work, illumination of rooms in relation to, 809-811.  
 Metabolism, light energy in relation to, 280-283.  
 Methemoglobin, spectrum of, 274.  
 Minim lamp, 578-580.  
 Mirrors, 31.  
 Mirrors, concave, 32.  
 Mirrors, concave, for concentration of solar light, 441-445.  
 Mirrors, Mangin, 33, 481, 482.  
 Mirrors, parabolic, use of, 436.  
 Mercury vapor lamp, 125, 658, 659.  
 Micron, 68.  
 Micro-organisms, production of light by, 199.  
 Microscopic reactions due to concentrated electric arc energy, 533.  
 Mobile equilibrium, 46.  
 Motor excitation, rôle of light energy in production of, 287.  
 Movements of growth in plants, influence of light upon, 148.  
 Mucous membranes, concentrated electric arc energy in treatment of, 506.  
 Mucous membranes, concentrated incandescent light energy in treatment of, 548-550.  
 Muscular fiber, action of light energy in stimulation of, 301-303.  
 Muscular fiber, unstriped, action of light upon, 213.

## N

N rays, augmentation of phosphorescent light by, 681.  
 N rays, characteristics of, 678, 680, 685, 690.  
 N rays, discovery of, 675.  
 N rays, effect upon human tissues and organs, 682, 685, 680.

N rays, effect upon phosphorescent bacteria, 684.  
 N rays, place in spectrum of, 677.  
 N rays in relation to the infra-red end of spectrum, 690.  
 N rays in relation to mental effort, 687.  
 N rays, screens for observation of, 677.  
 N rays, significance of, 676.  
 N rays, sources and emission of, 681, 683, 687.  
 N rays used as a chemical reagent, 688.  
 N rays used in diagnosis, 689.  
 N radiation, distinction between that of nerve and muscle, 683.  
 Nævus vasculosus, concentrated electric arc energy in, 516, 517.  
 Negative corpuscles, relation to arc discharge, 116-123.  
 Negative corpuscles, mass of, 3.  
 Nephritis, incandescent baths in, 428.  
 Nernst lamp, 400.  
 Nernst lamp for light baths, 400.  
 Nernst lamp, radiant efficiency of, 400.  
 Nervous diseases, incandescent light baths in, 426, 427.  
 Nervous diseases, electric arc in, 381-387.  
 Nervous system, influence of colored light upon, 288.  
 Neuralgia, sciatic, treated by condensed solar light, 456.  
 Neuralgia, thorium in, 738.  
 Neuralgia, ultra-violet light for, 639.  
 Neurasthenia, sun baths in, 322.  
 Neurasthenia, electric arc baths in, 381.  
 Normal skins, action of light energy upon, 237.

## O

Obesity, incandescent light baths for, 420-422.  
 Opaque bodies, 39.  
 Oscillating light corpuscles, 6.  
 Otitis media, concentrated light energy in, 557.  
 Oxyhemoglobin, spectrum of, 273.  
 Ozana, arc light in, 647.

Ozæna, concentrated light energy in, 557.

Ozone, 116, 490.

## P

Parallel rays, 25.

Parabolic mirrors, 33.

Parasitic diseases, vegetable, 507.

Pelvic tissues, sensitization of, 556.

Pemphigus neonatorum, ultra-violet light in, 635-637.

Pemphigus neonatorum, chronic, blue light energy in, 637, 638.

Penetration of light, 53.

Perception of light by retina, 24.

Pertussis, treatment of, by condensed solar light, 450.

Phosphorescence, 75, 77.

Phosphorescence of bacteria, oxygen necessary to, 197.

Phosphorescence, influence of temperature in, 197.

Phosphorescence, sodium chlorid necessary to, 198.

Phosphorescent light, action of N rays upon, 681.

Phosphorescent light, bacterial action of, 787.

Phosphorescent light, color of, 75.

Phosphorescent light, therapeutic action of, 787.

Photometers, 28, 29.

Photosphere, 40.

Phototaxy, positive and negative, 130.

Photo-speculum, for use of light in gynæcology, 552-554.

Pigment, rôle of light in production of, 214-217.

Pigment cells, contractile, 217.

Pigmentation of skin, as a factor in natural selection, 264.

Pigmentation of skin, as protective, 238, 239.

Plant life, electric light effects on, Cornell University experiments, 161, 162.

Plant life, Dehérain's experiments, 159-161.

Plant life, Siemens' experiments, 155.

Plants, blossoming, influence of light upon, 155.

Plants, life of, in darkness, 142.

Plants, locomotor movements, 152.

Plants, movements of growth of, 148.

Plants, structure of, influence of light upon, 149.

Pneumonia, lobar, treatment by condensed solar light, 454.

Positive rays, see Canalstrahlen.

Power of radiant energy, 4.

Prisms, 38.

Protoplasm, action of luminous rays upon, 130.

Prurigo, summer, or p. estivale of Hutchinson, 791.

Psychoses, exclusion of the chemical frequencies in, 599-601.

Pulmonary tuberculosis, condensed solar light for, 450.

Pulse, respiration and temperature, influence of light upon, 284.

## Q

Quantity of light a necessity, 94.

Quartz, lenses or plates of, 470, 471.

## R

Radiant energy, kind of, 52.

Radiant heat, 8, 43.

Radiation, attraction and repulsion of, 62.

Radio-activity of the air, mineral springs, rivers, sea, 721-723.

Radio-activity, nature and cause of, 725.

Radio-activity, theory of, 725.

Radio-activity of uranium, 697-701.

Radio-activity, value of, in relation to time, 724.

Radio-active bodies, penetrating power of, 711.

Radio-active bodies, variations of activity of, 724.

Radio-activity induced, in relation to substances in solution with radium, 723.

Radio-activity induced, rôle of gases in, 720.

Radio-activity induced in therapeutics, 747.

Rad'ometer, Crookes, 62.

Radium, action upon bacteria, 726.

Radium, action upon cancer cells, 742.

Radium, action upon chlorophyll containing organisms, 729.



- Radium, action upon growing seeds, 743.
- Radium, action upon vegetable and animal organisms, 728.
- Radium, action of magnetic field upon, 708.
- Radium, activation by, 720.
- Radium, atomic transformation of, hypothesis, 725.
- Radium, atomic weight of, 699.
- Radium, destructive action of, 729.
- Radium, chemical effects of, 713.
- Radium emanations, nature of, 723.
- Radium, emission of gas in presence of, 723.
- Radium, emission of heat by, 716.
- Radium energy of radiation, 702.
- Radium, extraction of, 699.
- Radium, fluorescent and luminous effects of, 712-715.
- Radium, induced activity of, 719.
- Radium, photographic power of, 718.
- Radium, production of thermoluminescence by, 717.
- Radium, quantity of, 699.
- Radium, physiological effects of, upon the excitability of the cerebral cortex, 733.
- Radium, physiological effects of, upon the eye, 732.
- Radium, physiological effects of, upon the nervous system, 738.
- Radium, physiological effects of, upon the skin, 730.
- Radium salts, characteristics of, 701.
- Radium, receptacles for the use of, 749, 750.
- Radium, spectrum of, 700.
- Radium, sources of, 698.
- Radium, theories as to action of, 739, 742, 743.
- Radium, therapeutic uses of, 734-746.
- Radium bromid, evolution of helium from, 716.
- Radium radiations, complexity of, 705.
- Radium radiations, demonstration of absorption of, Strutt, 703.
- Radium radiations, demonstration of negative charge of, Paschen, 704.
- Radium radiations, distance of propagation in the air, 711.
- Radium radiations, ionizing action of, 712.
- Radium radiations, proportion of deviable rays, 711.
- Rays, alpha, 22, 706.
- Rays, alpha, action of the magnetic field upon, 709.
- Rays, beta, 22, 707.
- Rays, beta, influence of the air upon, 710.
- Rays, Becquerel, 694, 695.
- Rays, cathode, 16-21, 653, 665.
- Rays, convergent, 25.
- Rays, divergent, 25.
- Rays, gamma, 707.
- Rays, Lenard's, 18.
- Rays, luminous, effects upon protoplasm, 130.
- Rays, N rays, 675-690.
- Rays, parallel, 25.
- Rays, positive, see Canalstrahlen.
- Rays of radium, 706, 707.
- Rays, Roentgen, see X rays.
- Rays, X rays, 14, 506, 507.
- Rays, ultra-violet, 12, 615-623, 176-189.
- Red light (or the red frequencies), in erysipelas, 593.
- Red light, exclusion of all other light energy save, 581, 583.
- Red light, influence of, upon excitability of the cortex, 291-300.
- Red light in measles, 592.
- Red light in neurasthenia, 598.
- Red light in other diseases, 596.
- Red light results in relation to technique, 594.
- Red light in smallpox, Finsen's technique, 590, 591.
- Red light in smallpox, historical, 583-585.
- Red light in smallpox, therapeutic results, 585-588.
- Regulators of the electric arc, 113.
- Refraction, 34, 38.
- Refraction by concave lenses, 37.
- Refractive index, 37.
- Reflection, 31, 38.
- Reflection of heat, 47.
- Region, ultra-violet, 70, 603, 609, 622.
- Respiration, influence of light upon, 284.

- Respiratory chemism, influence of light upon, 218.
- Respiratory diseases, incandescent light bath in, 427.
- Resistance of carbons, 480.
- Rheumatism, incandescent light baths in, 422, 423.
- Rheumatoid arthritis, incandescent light baths in, 423, 424.
- Rivers, disinfectant action of light upon, 175.
- Rock salt, transmission through, 56.
- Rodent ulcer, concentrated electric arc energy in, 516.
- Roentgen rays, see X rays.
- Rumford's photometer, 29.
- S
- Sarcoma, use of radium for, 740-743.
- Sciascia's sun lens, 437-440.
- Screens, blue glass, 478.
- Screens for N rays, 677.
- Screens, thermal, 59.
- Searchlight, marine, 350, 477-480.
- Sensitization, 415.
- Sensitization of bacteria, 189-192.
- Sensitization, Dreyer's conclusions on, 773.
- Sensitization of living tissues, 766.
- Sensitization of pelvic tissues, 556.
- Sensitization in relation to fluorescence, 774, 775.
- Sensitization in relation to chlorophyll function, 768.
- Sensitizers, action of, upon bacteria and animals, 771, 772.
- Sensitizers in photography, 767.
- Septic processes, concentrated electric arc energy in, 518-520.
- Siemens' experiments, 155.
- Skin of animals, action of light upon, 214.
- Skin conditions, brush light for, 632.
- Skin, diseases of, essentials for the light treatment of, 461-463.
- Skin, experimental study of action of light upon, 250-254.
- Skin, normal action of light upon, 237.
- Skin, preparation of, for treatment, 500.
- Skin, radium effects upon, 730.
- Skin, reaction of chemical frequencies upon, 259.
- Skin reactions, acute, from intense light, 237.
- Skin, selections of mechanisms for treatment of, 465.
- Skin, supersensitive, pathological effect of sunlight upon, 790.
- Skin, vascular alterations at level of, 263.
- Smallpox, action of light in, 797.
- Smallpox, Finsen's technique for, 590, 591.
- Smallpox, protection of face in, 595.
- Smallpox, red frequencies in, 583-588.
- Smallpox, vesicles of, how affected by chemical frequencies, 589.
- Sodium, rate of vibration, 72, 86.
- Solar erythema, epidermic lesions of, 246-250.
- Solar erythema, histology of, 242-246.
- Solar light, condensed, 438-457.
- Spark discharge, in relation to arc, 650.
- Spark discharge, theory of, 661.
- Spark lamp, Görl, 623.
- Spark lamp, Piffard, 625.
- Spark lamp, Strebel, 624.
- Spark lamp, Strong, 629.
- Spark lamp, vaginal, 626.
- Spark light, technique of, 632.
- Spark light in venereal warts and ulcers, 646.
- Spectra, absorption, 73.
- Spectra of different light sources, 80.
- Spectra of electric arcs, 100.
- Spectroscope, 79.
- Spectrum analysis, 65.
- Spectrum of carbon, 491.
- Spectrum, continuous, 12.
- Spectrum, Fraunhofer's lines of, 67, 68, 86.
- Spectrum of hemoglobin, 270.
- Spectrum, infra-red, 54.
- Spectrum, invisible, 69.
- Spectrum of methemoglobin, 274.
- Spectrum of oxyhemoglobin, 273.
- Spectrum of radium, 700.
- Spectrum, solar bands of, 41.
- Spectrum, ultra-violet, 603-606.

Spectrum, visible, 69.  
 Spintharoscope, Crookes, 710.  
 Spintharoscope, phenomena of, 711.  
 Strebel spark lamp, 624.  
 Structure of plants, influence of light energy upon, 149.  
 Sun, physical condition of, 40.  
 Sun lens, 437.  
 Sun spots, 40.  
 Sun baths in anæmia and chlorosis, 322.  
 Sun baths, construction of, 312-314.  
 Sun baths, effects of, 320, 325.  
 Sun baths, Finsen's method of, 317.  
 Sun baths, physiological action of, 319.  
 Sun baths upon the sea, 315.  
 Sun baths, technique of, 324.  
 Sun baths, therapeutic use of, 321-323.  
 Sun baths in tuberculosis of joints, 315, 317.  
 Sunburn, electric, 241.  
 Sunburn, glacial, 239.  
 Sunlight, conditions of chemical intensity, 308, 309.  
 Sunlight, comparative intensity of, 3.  
 Sunlight, pathological effect upon supersensitive skin, 790.  
 Sunlight, thermal analysis of, 51.  
 Sunstroke, 798, 800.  
 Sunstroke, prophylaxis of, 800, 801.  
 Synovitis, concentrated electric arc energy in, 523, 524.  
 Syphilis, fluorescent stimulation in, 763-766.  
 Syphilis, tertiary, a case of, 644-646.  
 Syphilis, theories as to active agent in light and fresh air, 641.

T

Temperature of body, influence of light upon, 284.  
 Temperature of boiling carbon, 96.  
 Thorium, hydroxid of, 746.  
 Thorium in neuralgia, 738.  
 Tic douloureux, treatment by condensed solar light, 457.

Tissue reactions in lupus, as observed by Glebowsky, 535, 536.  
 Tissue reactions in lupus, as observed by Leredde and Pautrier, 536, 539.  
 Tissue reactions in lupus and ulcus rodens, as observed by Sack, 533-535.  
 Tissue reactions, ultra-violet energy in relation to, 183.  
 Tissues, compression of, 492-496.  
 Tissues, compression of, by lenses, 497.  
 Toxæmia, incandescent light baths in, 430-434.  
 Toxins, action of light upon, 199-201.  
 Transformation of form under influence of light, 135.  
 Transformation of light energy into electromotive energy, 147.  
 Transformation of refracted light, 38.  
 Transillumination, fluorescent, 786, 787.  
 Translucent bodies, 39.  
 Transparent bodies, 39.  
 Treatment, necessity for prolonged, 499.  
 Tubercular ulcers, 525.  
 Tuberculosis, arc light baths in, 341-373.  
 Tuberculosis, marine searchlight mechanisms for, 350.  
 Tuberculosis pulmonalis, concentrated electric arc energy in, 526.  
 Tubes, Geissler, 655-657.  
 Tubes, mercury vapor, 658-659.  
 Tubes, vacuum, 649-674.

## U

Ultra-violet energy from alternating current, 628.  
 Ultra-violet energy from an influence machine, 627.  
 Ultra-violet energy, maximum chemical, 603.  
 Ultra-violet energy, maximum solar, 603.  
 Ultra-violet energy in syphilis, 640, 647.  
 Ultra-violet energy in syphilis, theories as to action of, 641-644.

- Ultra-violet frequencies, characteristics of, 617.
- Ultra-violet frequencies, penetrability of, 256, 258.
- Ultra-violet frequencies, photoelectric effects of, 618-620.
- Ultra-violet frequencies, relation to visible chemical frequencies, 573.
- Ultra-violet light, in acne rosacea, 639.
- Ultra-violet light in acne vulgaris, 639.
- Ultra-violet light, action upon skin, 613.
- Ultra-violet light, apparatus for, 623-629.
- Ultra-violet light, chemical changes by, 612.
- Ultra-violet light, choice of light source in relation to pathology, 632.
- Ultra-violet light, electroscope test for, 613.
- Ultra-violet light, electroscopic differentiation between, and X rays, 615.
- Ultra-violet light, field of usefulness for, 631.
- Ultra-violet light, production of fluorescence by, 607.
- Ultra-violet light in furuncle, 639.
- Ultra-violet light, inflammatory reaction from, 631.
- Ultra-violet light, influence of screens of glass upon, 613.
- Ultra-violet light in lupus vulgaris, 639.
- Ultra-violet light in neuralgia, 639.
- Ultra-violet light in pemphigus neonatorum, 635-637.
- Ultra-violet light, properties of, 612.
- Ultra-violet light in recurrent carbuncle, 639.
- Ultra-violet light in sycosis, 639.
- Ultra-violet light, transmission of, 608.
- Ultra-violet light, willemite as a test for, 610.
- Ultra-violet rays, 12.
- Ultra-violet rays, bactericidal effect of, 623.
- Ultra-violet rays, bactericidal effects of, experiments by Freund, Bie, Bang, Bernard and Morgan, 176-189.
- Ultra-violet rays, compared with X rays, 615, 617.
- Ultra-violet rays, effect upon eye, 804.
- Ultra-violet rays, methods of production, 621.
- Ultra-violet rays in relation to the electric spark, 622.
- Ultra-violet rays in relation to therapeutics, 621.
- Ultra-violet region, 70.
- Ultra-violet region, absorption in, 609.
- Ultra-violet region, influence of temperature in, 603, 622.
- Ultra-violet spectrum from electric arc, 603.
- Ultra-violet spectrum, means of studying and utilizing, 603.
- Ultra-violet spectrum from sun, 602.
- Ultra-violet spectrum, theoretical completion of, 606.
- Ultra-violet waves in relation to Roentgen waves, 604.
- Ultra-violet waves, velocity and intensity of, through glass, 605.
- Ulcers, tubercular, concentrated electric arc energy in, 525.
- Ulcus rodens, radium in, 734-737.
- Ulcus rodens, regressive and productive tissue changes in, 533-535.
- Unstripped muscular fiber, action of light energy upon, 213.
- Uranium, radio-activity of, 697-701.

## V

- Vaccine, action of light upon, 199-201.
- Vacuum tube, anodic stream, 653.
- Vacuum tube, appearance at anode and cathode, 652.
- Vacuum tube, cathode rays of, 653.
- Vacuum tube in relation to chemical efficiency of negative terminal, 670.
- Vacuum tube discharges, action of, 671.

Vacuum tube discharges, relation to arc, 649.  
 Vacuum tube discharges, theory of, 663.  
 Vacuum tube discharges in therapeutics, 669, 672-674.  
 Vacuum tube, emission of rays by, 665.  
 Vacuum tube, emission of cathode rays, 665.  
 Vacuum tube, fluorescence of, 651.  
 Vacuum tube, luminescence of, 657.  
 Vacuum tube, mechanisms for, 666, 667.  
 Vacuum tube, phenomena in, 652.  
 Variola, see smallpox.  
 Vegetable parasitic diseases, therapeutic indications for concentrated electric arc energy in, 507.  
 Visible chemical frequencies, action of, in relation to analgesia, 573-575.  
 Visible chemical frequencies, action of, in relation to ultra-violet frequencies, 573.  
 Visible chemical frequencies in hysteria, 577.  
 Visible chemical frequencies, indications other than surgical, 575-577.

Visible chemical frequencies, relation to acute processes, 578.  
 Visible chemical frequencies, summary, 578.  
 Vital activity of animals, action of light upon, 217.  
 Volatilization of carbon, 87.  
 Voltage, resistances to cut down, 468.

## W

Water-cooled compressing lens, 469-470.  
 Water-cooled vaginal lamp, 550-552.  
 Wave lengths, complex of, in relation to therapeutics, 612.  
 Waves, ultra-violet, 604, 605.  
 Weight, variations of, in animals in light and darkness, 218.  
 Wiring in relation to ampèreage, 468.

## X

X rays, 14.  
 X rays and light, choice between, 506, 507.

## Z

Zeroderma pigmentosum, 795.  
 Zeroderma pigmentosum, delayed, 796.









3 9002 01085 0866

904C  
Cloche



**CoLibri**

YALE UNIVERSITY  
UNIVERSITY in Italy



08 STD



CUSHING/WHITNEY  
MEDICAL LIBRARY

